

VOLUME CXI

NUMBER FOUR

# THE NATIONAL GEOGRAPHIC MAGAZINE

APRIL, 1957

- Rome: Eternal City with a Modern Air 437  
With Map and 46 Illustrations HARNETT T. KANE  
32 in Color B. ANTHONY STEWART
- Hydrofoil Ferry "Flies" the Strait of Messina 493  
With 8 Illustrations GILBERT GROSVENOR  
6 in Color LUIS MARDEN
- The Wild Animals in My Life 497  
With 26 Illustrations WILLIAM M. MANN  
19 in Color R. F. SISSON and DONALD McBAIN
- A Visit to the Living Ice Age 525  
With Map and 47 Illustrations  
42 in Color RUTHERFORD PLATT
- Three Roads to Rainbow 547  
With Map and 12 Illustrations  
9 in Color RALPH GRAY
- Rockets Explore the Air Above Us 562  
With 21 Illustrations NEWMAN BUMSTEAD

Seventy-two Pages of Illustrations in Color

PUBLISHED BY THE  
NATIONAL GEOGRAPHIC SOCIETY  
WASHINGTON, D. C.

\$7.00 A YEAR

75c THE COPY

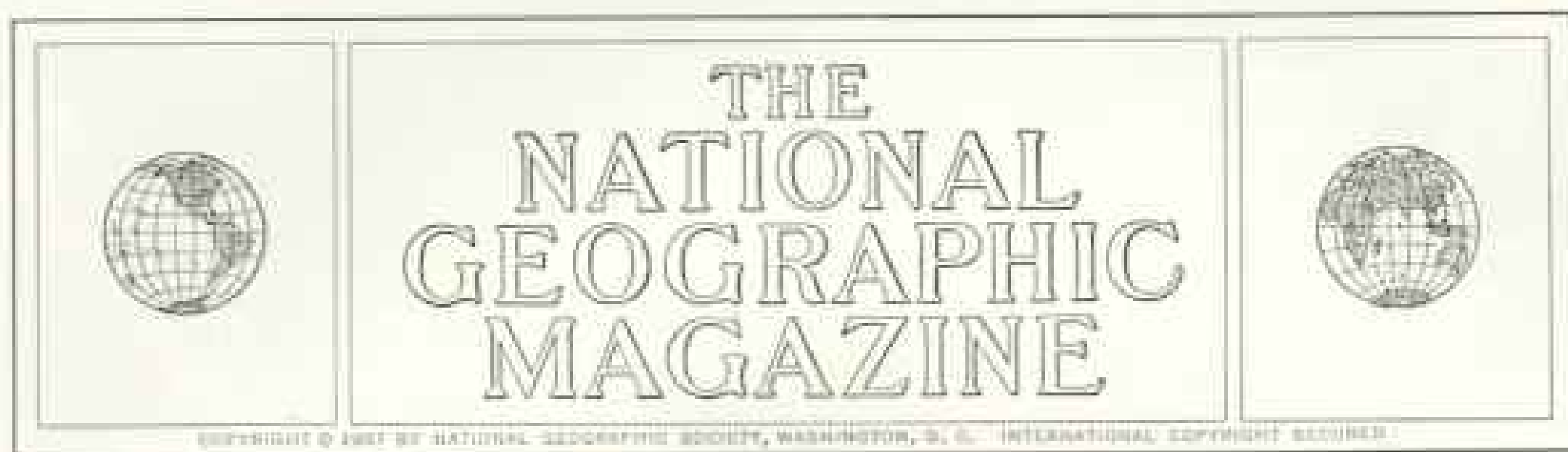

## Rome: Eternal City with a Modern Air 437

BY HARNETT T. KANE

*With Illustrations by National Geographic Photographer B. Anthony Stewart*

"AH, I don't know how it started or why, but, signore, it's all around us—this rebirth of Italy—like the bright glow over Rome."

My Roman friend, an intent young architect, gestured toward the ancient city. It shone below our trellised hill, yellow-red in the sunset of a mild June evening.

"Consider, signore. Only 10 short years ago our country lay broken, pulverized in the backwash of war. Many of our finest towns and villages were smashed—but completely!

"It was not mere bricks that had tumbled into the dust. It was our spirit, our hopes. What would you expect after 25 years of Mussolini's hollow glories and months of living under Hitler's heel?"

### Italy's Comeback Spectacular

The architect looked somberly into his glass. Then he brightened. "But we have come back!" he cried. "Rome the eternal never dies. No, she has put forth green shoots, she has flowered again in art, in music, writing, design—in a dozen fields of the mind and spirit. What you see here, signore, is a rebirth—Italy's second Renaissance."

I nodded. Through my mind echoed phrases then in the air that seemed to confirm his proud declaration: "In the Italian manner" . . . "the Roman style" . . . "Roman elegance" . . . For tens of thousands of Americans, as for people of many other nations, the city by the Tiber has become a powerful magnet.

That evening atop a hill our party sat at a cafe table among files of towering cypresses and pines, with statues in marble togas stand-

ing about us like ghosts watching in the growing gloom.

We caught a flurry of movement, excited voices; to the next table came a group of American college girls. Their hair was cropped in "the Italian way," which overnight had revolutionized Anglo-Saxon coiffures. In a rush they talked of the new designers of high fashion who are making Italy a major style center of the Continent.

### Ancient City Nourishes a New Art

As we listened, the girls also spoke of Cine Città, the film "city" in the Roman suburbs that has emerged as a great European movie center of considerable importance in the international market. "I turned, and there was Magnani herself!"

We heard more names—Gina Lollobrigida, Sofia Loren, and others that have become household words, even if mispronounced, from Brooklyn to Soho; and also the names of Italian writers who are bringing new critical recognition to their country.

The girl nearest me pointed: "Look over there." In the distance, as if painted on the clouds, rose the towers and spires of Vatican City; and over them all glowed the dome of St. Peter's, Michelangelo's masterpiece of art

### The Author

Harnett T. Kane, distinguished author and traveler, has written 16 books about his native New Orleans and the South, including *Natchez on the Mississippi*, *Bayous of Louisiana*, and *Plantation Parade*. To the NATIONAL GEOGRAPHIC MAGAZINE he has contributed "New Orleans: Jambalaya on the Levee," February, 1953, and "Trieste—Side Door to Europe," June, 1956.



### Domed Crown of Vatican City Is St. Peter's Church, the Largest in Christendom

A place of soothsaying (*patiscinatio*) in pagan times, Vatican Hill was already an arena of death when Nero built his Circus at its foot. Here he had countless Christians tortured and burned alive. Tradition says the Apostle Peter was crucified head down in the Circus. In the 300's the Emperor Constantine reared a basilica above his grave. Replacing that older sanctuary, this renowned edifice took more than a century to build. Recent excavations beneath the dome confirm existence of a cemetery with a tomb believed to be St. Peter's.



### Pilgrims Enter the Papal Domain Through the Keyhole of Bernini's Twin Colonnades

Italy by treaty in 1929 recognized the Vatican as a sovereign state, last remnant of the Popes' temporal kingdom, which once included all Rome and much of Italy. Only 1,000 people reside within the walled 108 acres, yet this tiny state commands the religious allegiance of the world's 469,500,000 Roman Catholics. St. Peter's Square sweeps around the obelisk that Caligula plundered from Egypt and set up in the Circus. Pope Pius XII lives in the 1,000-room Papal Palace at left behind the far colonnade. Vatican Library, museums, and Papal Gardens spread beyond (map, p. 444).

and engineering—a sight that has quickened the spirits of beholders for centuries.

There, we agreed, beat the heart of another durable Roman power. Working in his chambers until long after dark was Pope Pius XII, whose spiritual authority enfolds some 469,600,000 men and women around the globe. Under his guidance the Roman Catholic church now exercises a powerful influence over more men, from peasants to royalty, than at any other time in its 1,900 years of existence (page 466).

A silence fell on our group. It was my third visit to Rome, and the spread of towers and steeples brought back to me the hour of my first arrival some years earlier.

Like many another foreigner I had felt let down at first. Settling dustily into a cab, I stared at rows of badly lighted structures, all looking alike in the gloom. After the fresh, tidy color of medieval Bern and the matchless expanses of Paris, Rome seemed drab indeed.

#### Imperial Capital Comes to Life

Then the street widened. A jet of foaming water darted skyward, and a spotlight outlined a marble figure. A glow illuminated a rectangle of buildings, and I recognized the Renaissance front of a building I had studied in school. Beyond opened a *piazza*, one of Rome's many open squares, like a stage set thronged with players. The city of the Romans had come alive for me.

A child ran before us; brakes screeched. The youngster's frightened mother caught him up to punish him, but her overflowing love made her kiss him instead. Before tables on the sidewalk a singer threw out impudent verses. Against the ripple of the fountain, the sound of a violin rose in the evening; a couple embraced in the shadows.

Since then, Romans have talked to me endlessly about their city and its hold upon them. For Rome is a special part of Italy, as the Roman is a special kind of Italian. The city is as far in spirit from industrial Milan of the north as from pastoral Sicily of the south. It is primarily a center of government; next, a center of trade and exchange, and also, always, of the Roman Catholic Church.

The Romans are proverbial for their faith in themselves and in their city. For them this is the true home of civilization. And, as a matter of fact, Rome keeps gaining meas-

urably in importance for Italy and for Europe.

In recent years the city's population has increased astonishingly, much like certain thriving areas of the west coast of the United States. Because of continuing hardship in southern Italy, tens of thousands move northward. They pack ever more heavily into the expanding capital, which continues, as always, to turn them into Romans.

#### "When In Rome..."

Even I, who had started out to live my time in Rome as an American, soon found my ways changing. On my second day I left a congenial group to telephone and was asked: "What's important enough to interrupt when we're having a good time?"

"I promised to phone, and I have to get to the Ministry of —"

My friend looked sad, then earnest. "Please! Stop making calls and appointments. If it's really big, they'll find you. If it isn't, you're that much ahead. You understand?"

Gradually I did. Planning an automobile trip to near-by hill towns with the Italian-American painter Salvatore Meo and two other Romans, I worried over one delay after another and finally said I would *have* to start by Friday. I got a depressed stare: "He's acting like a train dispatcher."

I gave in. We left Sunday and stayed three days longer than planned. I was learning.

Meanwhile I came to know well a small circle at what was soon one of my favorite afternoon places, a cafe along the wide and teeming Piazza del Popolo. We sat together regularly—a lawyer and his wife, a pert girl who worked for the Government, and several actors—against a panorama that must be one of the world's most beguiling.

Page 441

#### A Cascade in Stone, the Spanish Steps → Ripple Past Banks of Azaleas

Pincian Hill's monumental staircase, a bequest of a French diplomat, was built in 1725 and named for the Spanish embassy at its foot. The neighborhood was famed as a haunt of the English colony. John Keats died in the house at lower right. Now a museum, the building preserves mementos of Shelley, Byron, and Leigh Hunt, as well as Keats.

The 137 steps climb from the Piazza di Spagna, divide below the Roman copy of an Egyptian obelisk, and stop beneath the twin bell towers of Trinità dei Monti, a church built in the decade Columbus discovered the New World. The French Convent of the Sacred Heart abuts the church on left; Hassler Hotel rises on the right (page 448).

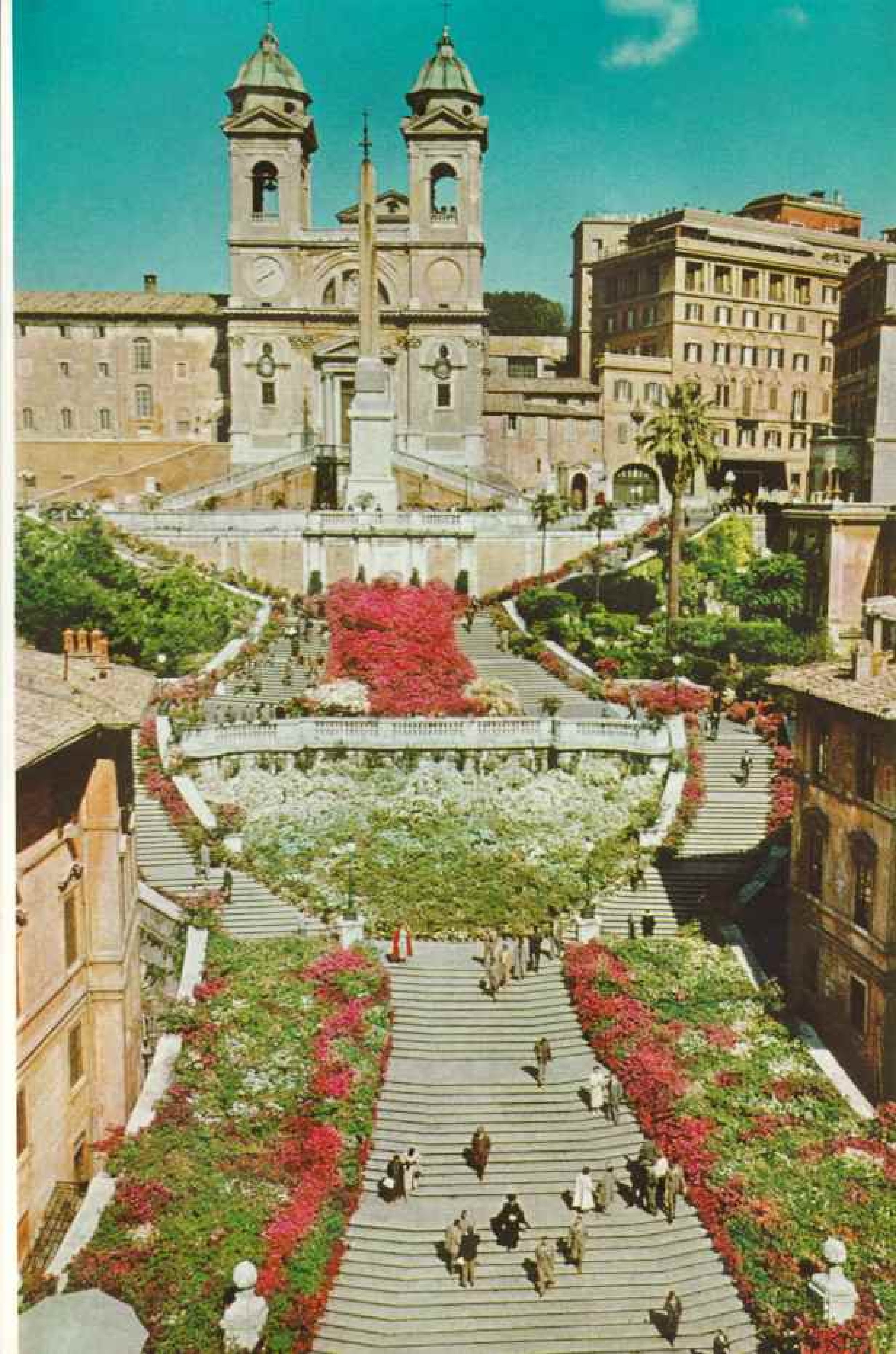



Like so much in Rome, "il Popolo" was, and is, many things in combination: A curved area with twin Italian Baroque churches on one side, a general neoclassic design carried out for Napoleon, fountains with lions, and an obelisk honoring Rameses II and topped with a Christian cross. Yet it had, again like so much of Rome, a unity in its diversities.

#### No Strangers in Menghi's

After an hour or so we would walk from Popolo to Menghi's, a small restaurant on the Via Flaminia. It is a happily mixed place, with laborers in a plain front room and a gaily ornamented second room full of artists and movie people, a clientele much like the cast of *La Bohème*. Practically everybody knew everybody else, or soon did, over golden Frascati.

At other times I was welcomed at a small house in the Campagna, the near-by countryside, for hours redolent of tomato sauce,

garlic, and warm cheer. And down the street from my apartment I made the joyous acquaintance of a shopkeeper who had 15 birds in cages, a daughter in New Orleans, and a booming good will toward the world in general and America in particular.

With them all I learned to appreciate the Roman way—the informal hour in the courtyard or at the edge of the street, with children rolling under our chairs, friends calling from windows, neighbors coming and going with easy greetings, a priest passing with a cheerful "*buon giorno*," street salesmen offering their wares, and everybody talking, arguing, listening.

That was the Rome I enjoyed best—Rome of the casual assembly, half indoors, half out. The Roman likes his home, but he likes no less the piazzas, those places that some call open-air residences, shared with a whole neighborhood. At one side, perhaps, stands a ponderous *palazzo*, once the palace of a noble family and now a public building; at the



## Waiting for the Green Light, Swarms of Motor Scooters Line Up for a Dash into the Countryside

Roaring, darting scooters, outnumbering automobiles, dominate Rome's traffic. These toylike vehicles have swept Italy since the war, almost replacing the motorcycle. They have spread rapidly through Europe and on to the Far East.

Most popular is the Vespa (wasp), made by a onetime airplane manufacturer. Italians of modest budget like Vespa's low price (\$200 to \$250), its one-cylinder simplicity, and its economy (100 miles to the gallon). Top speed is about 45 miles an hour. Scores of Vespa clubs meet regularly for races and outings.

✦ Women ride, too. When papa drives, mamma sits side-saddle on the box seat, often with a baby in her lap. Youngsters stand between seat and handlebars.

— Paul Pletzech, *Black Star*

‡ Pletzech and Comment



443

other a church. Near by a *gelateria* sells ices.

The background is a curtain of splendor left a bit dusty through the generations. About it hovers a good-humored, shifting interest, lively and sharp tongued yet also relaxed. These people have their troubles. Shadows wait in the corners, but in the brightness of the sun there is life overflowing, an Italian animation that nothing yet has killed.

Like most newcomers and returning visitors, I felt confused for weeks by the jangling mixture of everything. In turn the capital of the pagan world, the hub of a powerful empire, and the center of world Catholicism, Rome retains much of each phase. This is no serene place with the unity of, say Renaissance Florence, or the single gay-proud mood of Venice. Slowly, however,



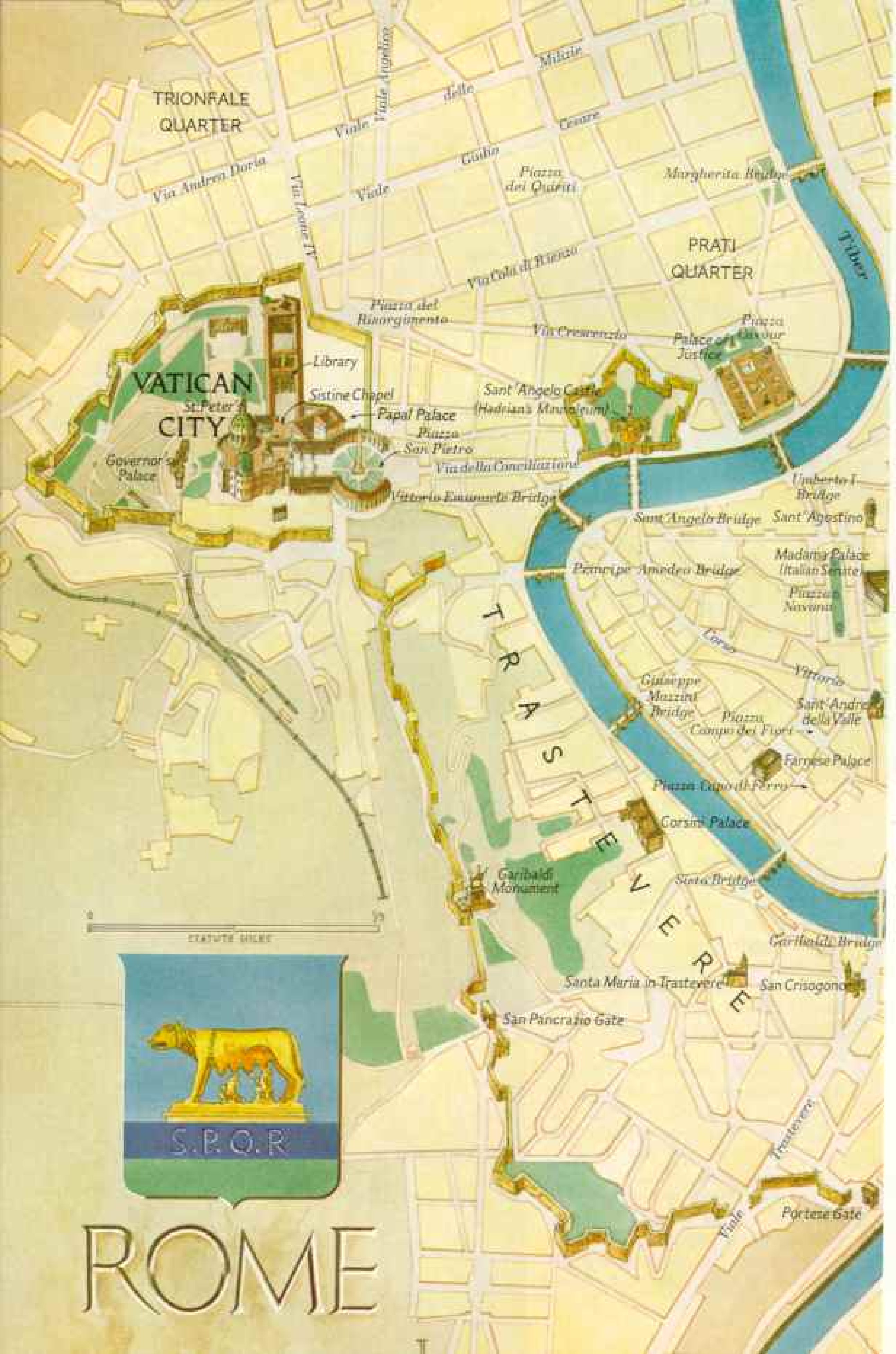

TRIONFALE  
QUARTER

Via Andrea Doria  
Via Leone IV

VATICAN  
CITY

Library  
Sistine Chapel  
Papal Palace  
Piazza San Pietro  
Governor's Palace  
Vittoria Emanuele Bridge

Sant'Angelo Castle  
(Hadrian's Mausoleum)

PRATI  
QUARTER

Milite  
Cesare  
Gullo  
Piazza dei Quarati  
Via Cola di Rienzo  
Via Cavour  
Palace of Justice  
Piazza Cavour  
Margherita Bridge

T  
R  
A  
S  
T  
E  
V  
E  
R  
E

Umberto I Bridge  
Saint Agostino  
Madama Palace  
Italian Senate  
Piazza Navona

Giuseppe Mazzini Bridge  
Piazza Campo dei Fiori  
San Andrea della Valle  
Farnese Palace  
Piazza Campitelli Ferro

Gorsini Palace  
Santa Bridge  
Garibaldi Bridge  
Garibaldi Monument

Santa Maria in Trastevere  
San Crisogono  
San Pancrazio Gate

Trastevere  
Portese Gate



ROME

500 METERS

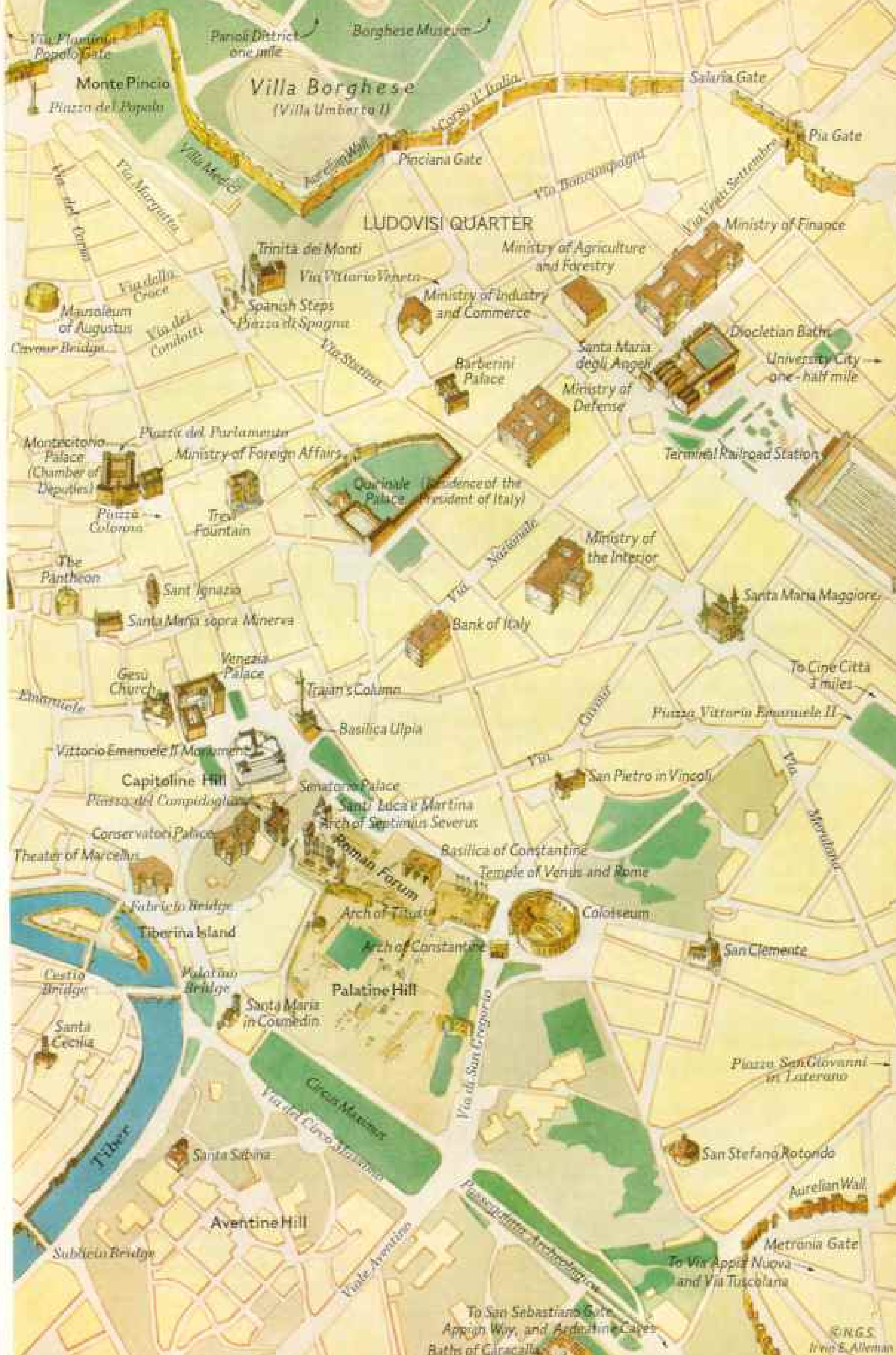

Via Flaminia  
Popolo Gate

Pincio District  
one mile

Borghese Museum

Salaria Gate

Monte Pincio

Villa Borghese  
(Villa Umberto II)

Corso d'Italia

Pia Gate

Piazza del Popolo

Pinciana Gate

Via Boncompagni

Ministry of Finance

LUDOVISI QUARTER

Trinita dei Monti

Ministry of Agriculture  
and Forestry

Via della Croce

Via Vittoriano Veneto

Ministry of Industry  
and Commerce

Mausoleum  
of Augustus

Spanish Steps  
Piazza di Spagna

Via dei Condotti

Via Salaria

Barberini  
Palace

Santa Maria  
degli Angeli

Diocletian Baths

University City  
one-half mile

Caracalla Bridge

Piazza del Parlamento

Ministry of Foreign Affairs

Montecitorio  
Palace  
(Chamber of  
Deputies)

Quirinale Palace  
(Residence of the  
President of Italy)

Ministry of  
Defense

Termini Railroad Station

Piazza  
Colonna

Trevi  
Fountain

Via Nazionale

Ministry of  
the Interior

The  
Pantheon

Sant Ignazio

Bank of Italy

Santa Maria Maggiore

Santa Maria sopra Minerva

Gesù  
Church

Venezia  
Palace

Trajan's Column

Basilica Ulpia

Piazza Vittorio Emanuele II

To Cine Citta  
3 miles

Emiliale

Vittorio Emanuele II Monument

Capitoline Hill

Senators Palace

Santi Luca e Martina  
Arch of Septimius Severus

San Pietro in Vincoli

Piazza del Campidoglio

Conservators Palace

Arch of Titus

Basilica of Constantine

Temple of Venus and Rome

Theater of Marcellus

Fabrizio Bridge

Roman Forum

Colosseum

Tiberina Island

Arch of Constantine

San Clemente

Cestio  
Bridge

Palatino  
Bridge

Palatine Hill

Santa Maria  
in Cosmedin

Piazza San Giovanni  
in Laterano

Santa Cecilia

Via del Corso  
Marmora

Via di San Gregorio

San Stefano Rotondo

Santa Sabina

Aurelian Wall

Aventine Hill

Via de' Aventini

Piazzale Architettonico

Metronia Gate

Subleita Bridge

To Via Appia Nuova  
and Via Tuscolana

To San Sebastiano Grotto  
Appian Way, and Atrianine Caves  
Baths of Caracalla

ENGS  
New E. Allen

impressions and points with special meaning for me began to sort themselves out.

One was a spot at the edge of the formal Borghese Gardens on one of the highest rises of the city, where a balustraded area thrusts like a ship's prow over the hazy yellow-pink sea of Rome's roofs.

Another was a fountain constructed like a boat in water, parallel to the Spanish Steps (page 441). This fantastic flight of steps is actually a combination of ever-outreaching flights. Generations of observers have described them as the world's handsomest. From below, toward dusk, the endless steps and the twin-towered church of Trinità dei Monti, with its own obelisk before it, take on a rosy glow that lasts an hour, then fades into the night.

There was also the point along the slowly rising Alban Hills outside Rome, from which the city seemed in the clear morning light like a print from a master's hand. And a stretch along the ancient Appian Way, reaching to the washed blue of the horizon, lined with tall trimmed pines and cypresses and sections of a broken aqueduct that once brought water to the city.

#### Via Appia Carried Caesar's Army

Along this major road of Roman dominion, on which Caesar marched with his men, clings the silence of the ages, until a bird sings faintly in a tree.

It is difficult not to be moved by a small church along this Via Appia, and its tale. During Nero's murderous campaigns against the early Christians, Peter the Fisherman fled Rome to save his life. Half a mile from the Porta San Sebastiano he had a vision of the Saviour. Peter asked: "*Domine, quo vadis?* Lord, whither goest thou?"

The reply was sad: "To Rome, to be crucified again."

Hearing that, Peter returned to the city for his own harsh death; now the humble yellow church of Domine Quo Vadis is said to mark the scene.

Hardly five minutes away waits the Rome of today. I stopped regularly at squares like the Piazza Campo dei Fiori, the square of flowers, an open space in a crowded section. Each morning the piazza closes to cars, and scores of people appear from nowhere to put up stalls for blossoms, for fish and meat, for vegetables and a great mixture of goods, new, secondhand, and third-hand.

Soon customers arrive from alleyways, doorways, and adjoining streets. Sellers eye them shrewdly, argue, tempt. Squid, clams, fowls, thick bunches of vegetables; tiny dolls, candy, colored boxes; cakes, umbrellas, cleaning fluid—all are offered with grins, groans, shrugs, and derisive shouts from stall to stall. Business is brisk.

The Italian salesman can be persuasive, and the customer has many small needs. The margin of gain is also small—a few lire an article; a man must sell thousands to make a living.

#### Market Stalls Vanish Like Magic

Slowly the human traffic lessens. At a signal everything is folded and put away on carts and trucks. The paving is washed, and life resumes without a trace of the recent bustle. About the square stroll two *carabinieri*, policemen with flowing capes, great shoulder straps, and tricorne hats with feathers. An old woman goes by with a cat in her arms; she is taking him to the park for a sunning.

Just ahead, restaurant owners have put up brightly covered tables along the sidewalks, with boxes of greenery as division lines, or none at all; here patrons eat spaghetti or minestrone under the eyes of passers-by. Past them whiz automobiles, the tiny ones called Topolino, or Mickey Mouse cars; motor scooters (page 442); bicycles; and three-wheeled vehicles with motors, glassed in so that they look like spaceships.

After a time I hardly noticed the clatter. But I never learned to adjust to the abandon of Roman traffic.

"What are the rules here?" I asked once.

Page 447

#### Late Morning Crowds Begin to Drift → to the Sidewalk Cafes of Via Veneto

Rome's gayest, most fashionable street is the half-mile stretch of Via Vittorio Veneto. From Doney's (foreground), Struga (next block), and Rosati's (across the street) tiny tables and gaudy umbrellas spill out along wide sidewalks. Twice daily—before lunch and in the evening—crowds clog the pavement, watching the fashion display and enjoying refreshments. Visitors rub shoulders with movie stars, writers, artists, and deposed monarchs.

For many who come to see and be seen, the outdoor cafes are a combination business office and mart. Many an actor is hired and many a deal is made over coffee cups and vermouth glasses.

Hotels, travel agencies, and offices line the street, which ends abruptly at the Pincian Gate, part of the ancient Aurelian Wall that still encloses the city's heart. Borghese Gardens lie beyond.





© National Geographic Society

448

↑ **Diners on Hassler Hotel's Terrace  
Enjoy a Monumental Panorama**

Italy's President works in the square-towered Quirinal Palace at left. Victor Emmanuel II Monument (right) is popularly called the Wedding Cake because its marble façade is so frosty and ornate.

↓ **Enrico Plays Mood Music  
in Ulpia's 1,900-year-old Ruin**

This unusual eating place puts a modern roof over an apex of Basilica Ulpia, which Emperor Trajan built as a hall of justice. Plaques and stone carvings from Trajan's Forum decorate the restaurant.



"Don't try to learn them," I was told. "Just watch out for the automobiles and bikes." A bus rocked around a corner, missing me by inches. My mentor added: "And the buses too." To survive Roman traffic calls for Roman courage.

Soon afterward, in one of my favorite piazzas, I learned about Italian courage of another sort.

My eye was caught by a man who stared at a bronze wall plaque. He removed his hat and blessed himself. The girl at my side explained that the plaque honored a worker who defied the Nazis when they took over Rome. He died in agony.

### Mother of the Western World

Peter the Apostle, roads of empire, an automobile called Mickey Mouse, Fascist despots—Rome encompasses them all. In 2,700 years of known history much that is good has happened here, and much that is bad. Rome mothered the civilization of the West; it offered a system of justice to the world, nurtured one of man's major religions and an important flowering of humanism and art. And at times it knew torment and degradation.

According to legend the city was founded by Romulus and Remus, sons of the war god Mars, suckled by a she-wolf (page 476). From a settlement of farmers and traders it grew into a small kingdom and then, 500 years before Christ, into a republic with a system of rights for its citizens that became a model for others. It took as its motto *Senatus Populusque Romanus*—"the Senate and People of Rome"—which still survives today in the form of the initials S.P.Q.R. on the city's shield (color map, pages 444-445).

This greatest power of ancient times stretched toward the ends of its world. Back rode swaggering victors, dragging trophies of gold, jewels, and art, parading kings and queens in chains.\*

All roads seemed indeed to lead to Rome, and into her narrow limits crowded slaves from Greece, from the East, and from each of the empire's subject places. The city reached a population it has only recently equaled, nearly a million and three quarters.

With enormous wealth came luxury, corruption, and callous disregard of the subject peoples. The Caesars fostered the pomp and purple of imperial Rome, and while the trappings of the republic were kept for a time, they soon lost their meaning.

Meanwhile from the conquered East there slipped in a new religious faith, regarded lightly at first. Against the garish imperial background the first Christians preached what was clearly subversion—worship of Christ rather than the emperor. Their belief grew largely among the poor and lowly.

Hundreds of them died, speared or disemboweled for an afternoon's entertainment, or made living torches to please the tyrant Nero. In his reign Rome was burned and St. Paul beheaded.†

Onlookers in Nero's Circus gloated over the grim scenes. Later the father of Church history, Eusebius, described how Christian martyrs, defying their persecutors, often did not complain or cry for help but died smiling until the last agony.

Such spirit could not be burned away. For millions this is Rome's finest story. Persecutors became believers, until some 300 years after Christ the Emperor Constantine took the faith.

But by this time temporal Rome was cracking. It seemed too big to be ruled as a single unit. Diocletian split it into Eastern and Western halves. Constantine shifted the capital to Byzantium, which became Constantinople and is now Istanbul, Turkey. Already Rome had heard rumblings of warlike tribes to the north. Now these so-called barbarians pressed down, and Rome fell before invading Goths.

### An Empire That Lasted 1,000 Years

The Goths smashed churches and looted until Alaric boasted that he left the Romans nothing except life itself. Yet the Goths, Vandals, and later invaders were impressed in spite of themselves and spared a great deal; each time Rome rebuilt.

Long before then papal Rome had been born. The churchmen who considered themselves St. Peter's successors as bishop of Rome exercised influence over Christians everywhere, and the pontiff of Rome became supreme among the bishops. In the middle of the

\* See "Ancient Rome Brought to Life," by Rhys Carpenter, with 32 paintings by H. M. Herget, in the NATIONAL GEOGRAPHIC MAGAZINE, November, 1946, and the National Geographic Society's 356-page book, *Everyday Life in Ancient Times*, \$5. in the U.S. and Possessions, \$5.25 elsewhere. Postpaid.

† For additional articles on Rome, see "Cumulative Index to the NATIONAL GEOGRAPHIC MAGAZINE."

† See "Jerusalem to Rome in the Path of St. Paul," by David S. Boyer, NATIONAL GEOGRAPHIC MAGAZINE, December, 1956.





### Blood-stained Arena of the Roman Mob, the Colosseum Has Endured 19 Centuries

Emperor Titus, using the labor of 12,000 captive Jews, completed the world's largest amphitheater A. D. 80. He inaugurated it with a blood bath. For 100 days the arena shook with the roar of 50,000 spectators, the screams of 3,000 wild beasts, and the death agonies of untold gladiators. Ignoring Christian protests, the carnival of death continued four centuries longer. Until recent times the Colosseum served as a marble quarry for builders.

Having withstood time, earthquake, and battle, the walls now threaten to crumble from automobile vibration. Roman police recently ordered traffic detoured around them. Six patched columns on the right survive out of nearly 200 that anciently formed part of the Temple of Venus and Rome. A bronze Nero seven feet taller than the Statue of Liberty stood between temple and Colosseum until it toppled some 1,700 years ago.



eighth century, King Pepin of the powerful German Franks gave the Pope sovereignty over the duchy of Rome, the exarchate of Ravenna, and other territories.

On Christmas of 800 Pope Leo III pressed an iron crown upon Charlemagne, Pepin's son, and proclaimed him emperor and Augustus. The empire of Charlemagne collapsed in the ninth century, but the imperial idea lived on and was the motivating force in the creation of the Holy Roman Empire. The empire ended in 1806; the Popes retained control of the papal states of central Italy until 1870.

Theirs was a risky authority, however, contested by scheming feudal lords and outside rulers. Successive Popes set up fortresses to match might with might, but two were mur-

dered, and several fled for their lives. Once the head of the church left for France, and for nearly 70 years Catholicism was ruled from Avignon.

Embattled Rome itself seemed doomed. Sieges brought famines and pestilence, and malaria epidemics killed tens of thousands. The population sank below 50,000. Cows grazed about the old Capitol.

But Rome would not die. Conditions improved; the Popes returned, and the glory of the Renaissance began. There appeared artists whose names today glow over the city—Raphael, Michelangelo, Bramante, Bernini, Cellini. Under papal patronage they contributed magnificent churches, palaces, princely homes with graceful fountains and stairs, and paintings and sculpture.

The 19th century brought fresh vicissitudes. Napoleon captured the city, its art, and its Pope, Pius VI. A few years later the French returned the Pope, but some of Rome's art still is displayed in Paris. Conversely, parts of the Eternal City still bear a Gallic touch.

Meanwhile Italy lay divided and city states thrived in fierce independence of one another: Venice, long-time queen of the Adriatic; Florence; and others. Spain, France, and Austria contested for control of the peninsula.

Gradually the movement for Italian unity gained strength; in 1870 Victor Emmanuel

*(Continued on page 461)*



#### ← Author Kane Clasps a Marble Hand Protruding from a Garden Wall

For centuries Romans freely despoiled the monuments, buildings, and art works inherited from their city's golden age. Marble facings were ripped away to dress new structures, walls pulled down to get building stones, statuary burned to make lime.

Today antiquities are protected by the Government. When possible they must be left in place (page 461).

Sometimes fragments are preserved by cementing them into masonry. This arm and the cherub's head grace the courtyard wall of the private Torlonia Museum in the Trastevere section.

#### Balconied Apartments in Parioli District → Borrow Curves of the Colosseum

Page 453: From classical times to the present, Rome has been a city of apartment dwellers—one reason the capital can contain its 35,000 newcomers a year in a relatively small area. Diplomats, film stars, and wealthy Italians make their homes in this fashionable area.

Horse-drawn cab remains one of the best ways to see Rome. The *drogheria* does not sell drugs, as its name implies, but groceries.





### Tattered Columns, Arch, and Senate House Rise from a Marble Wilderness . . .

In its heyday the Roman Forum covered 25 acres with temples, halls, colonnades, statues, and triumphal arches. After Rome fell, farmers pastured cattle in the grass-grown ruins. Today only three columns remain of the Temple of Vespasian (left). Arch of Septimius Severus (center) commemorates the emperor's victories in the East. Domed Church of Sts. Martin and Luke stands on the foundations of a hall used by senators for secret sessions.

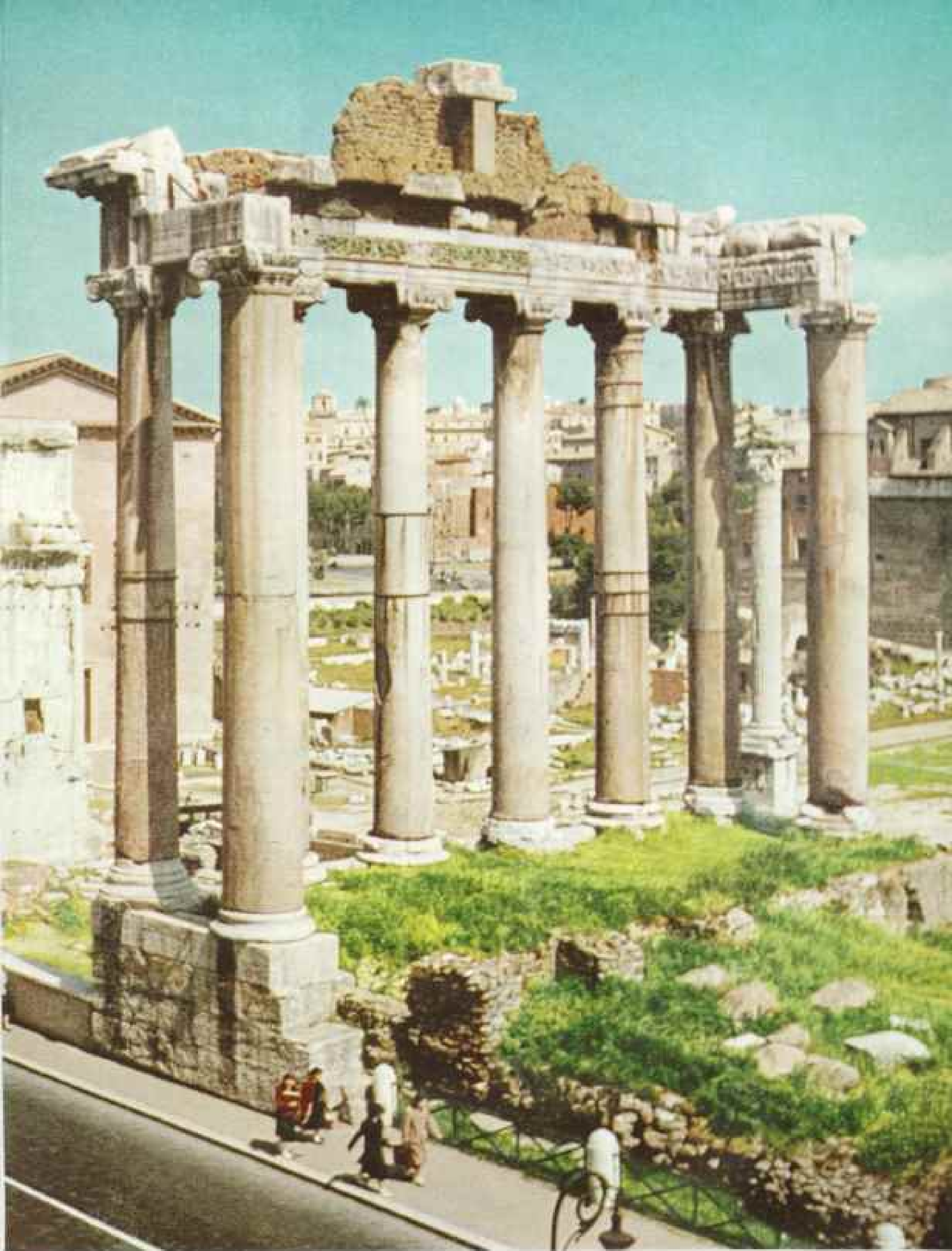

**. . . That Was the Forum, Seat of World Empire and Birthplace of Modern Law**

Eight columns mark the state treasury, known as the Temple of Saturn. Patrician statesmen decided the world's fate in the Curia, or senate house (half hidden by the arch), whose skeleton survived the Middle Ages as a church. Little remains of the Forum's courts, where Roman civil law evolved. Emperor Justinian's code in the sixth century reduced common usage to writing. American and most European legal systems are based upon Roman justice.



### Perjurers Beware! Mouth of Truth May Bite a Liar's Hand

The ancients carved this marble face to cover a well. Now the hollow eyes stare from the portico of the Church of Santa Maria in Cosmedin. In medieval times suspected perjurers were dragged before the image as a test of honesty. The mouth was reputed to gnash the hand of the guilty.

### Fountain of the Rivers . . .

This Bernini-designed fountain anchors an obelisk that once adorned the Circus of Maxentius. Figures symbolize the Ganges, Danube, Nile, and Plate Rivers. Seventeenth-century Rome flooded the piazza for water sports.

456



## Spirits Run Wild and Hats Go Mad in a Student Festival

Each spring the University of Rome explodes in a three-day carnival. Upperclassmen swarm through the streets soliciting money for a parade.

Bell ringer and whistle blower in the Borghese Gardens wear long-billed hats in the colors of their colleges. Hers is medicine; his is law.

## ... Flows in Piazza Navona

Navona Square rests on the first-century foundations of Emperor Domitian's Stadium.

Americans are fond of dining at the Tre Scalini (Three Steps) at extreme left. *Baul-etto*, veal stuffed with ham and cheese, is a specialty.

© National Geographic Society

457





### Verdi's *Aida* Weaves an Egyptian Love Story in the Cavernous Baths of Caracalla

Opened A. D. 217, Emperor Caracalla's public baths surpassed all others. For one copper coin any citizen could luxuriate in marble and mosaic elegance; the price covered use of pools, gymnasiums, libraries, and picture galleries. Romans enjoyed the baths until the sixth century, when Goths cut the aqueducts (page 478).



### A Cast of Hundreds Sings the Triumphant March on the Gigantic Stage

Each summer the city presents open-air operas in the ruined hot-water room. Lofty brick walls of the baths appear made to order as a backdrop for *Aida*, a story requiring armies, mobs, temples, horses, and camels. Here the Egyptians sing homage to Rhadames on his victorious return from the Ethiopian wars.



## Souls in Torment Commemorate a Wartime Tragedy

During the Nazi occupation in 1944, a bomb killed or wounded more than 30 German soldiers in the Via Rasella.

In reprisal Adolf Hitler ordered 10 Italians slain for every German casualty.

The next day 335 men and youths—only four of them involved in the bombing—were herded into the Ardeatine Caves south of the city and shot to death. Exploding mines covered the evidence with an avalanche of rubble.

After the Germans fled Rome, an Allied commission exhumed the bodies and investigated the massacre. Three generals served prison sentences for carrying out Hitler's order.

In 1949 Italians reburied the victims in a concrete mausoleum within the caves.

→ Visitors entering the vault pass this travertine monument by Francesco Coccia.

↓ Inside the crypt, grieving relatives and friends pray for the dead.

© National Geographic Society

460



II, king of Sardinia, breached the walls of Rome, ended papal rule, and turned the old city into the capital of a new nation. There followed a monarchy with ups and downs until, after the fall of Benito Mussolini, the nation became a republic.

Traces of this 27-centuries-long story may be found all over Rome; nowhere else, perhaps, does the present touch elbows so easily with the past.

The famous Aurelian Wall, built about 280, pushes its way across much of the city, which has grown around it. Through old archways ride automobiles and bicycles. A modern streetcar rumbles and clangs along another part of the wall.

Structures rise that are three eras in one—foundations of a pagan temple deep in the earth, an early Christian church above, and another from the middle ages at the present street level. Here is a layer cake of history. And at Rosati's cafe, a gathering place of fashionable Romans on the Via Vittorio Veneto, chic women walk to their tables past the marble figure of an emperor. He belongs there as much as they do.

#### Hadrian's Tomb Became a Fort

A kind of cultural co-existence has long been a Roman tradition. Generation after generation accepted, then modified, what it found. A first planner would die or be replaced; as tastes changed, a successor altered the design, but before he could enforce his will he also disappeared, and a third or fourth man completed the work.

Thus Castel Sant' Angelo, a massive circular structure, was planned by Emperor Hadrian as his tomb (pages 474, 475). In time it served as a papal fortress, where thousands huddled during sieges that decided Rome's fate.

Or consider the ponderous Theater of Marcellus. It became a fort and then a palace, and now newcomers live quietly in apartments over its empty arches.

Frequently Rome offers startling surrealism, such as doors built as great mouths or walls as grotesque faces. Yet many a striking view is simply the whimsical work of time.

In a neat courtyard an imposing figure in sculptured armor perches on a pedestal. But its head is gone. Near by an emperor's face with curls and headgear stares past the intruder: it fell from a statue and now it sits there, neck in the ground. A state ordinance

says that such fragments must stay, whenever possible, where found. Thus more and more the city has become an informal outdoor museum.

To preserve the fragments Romans sometimes stick them into walls. In a crowded tenement district I wandered into a courtyard from which a classic fist thrust forth, as if an ancient gladiator were punching his way out of the building.

Two thumbs extended incongruously from another wall, and above them emerged an angel's wings and the beautifully formed arm of a woman (page 452). Whenever a Roman digs foundations for a new building, he expects to meet more of his heritage from the past—a crusted coin, a carved ear, somebody's nose in stone.

#### Catacombs Were Lost 800 Years

Today, Romans and visitors alike meet much more of earlier Rome than could be seen even a century ago. Only recently have investigators had the means, the interest, and the knowledge to probe beneath the uneven surface. Rome for centuries forgot large sections of its area and the identities of many decayed structures.

Rome forgot even her catacombs, the famous underground passages longer than the ancient city's streets, where early Christians buried their dead. After the plundering of the catacombs by the Lombards in 756, Pope Paul I removed many relics to churches. The catacombs fell from men's attention until an accident discovered them 800 years later.

Again and again the Romans destroyed their past. A fresh victory, another name to be honored; down went the record of an earlier one. When an emperor, a prince, or a Pope saw a façade he liked, he appropriated it for a new use.

Great columns were lifted from one structure to another. The much-admired Arch of Constantine has medallions of hunting and sacrifices and a series of striking reliefs. In honoring Constantine the builders simply "borrowed" those decorations from the arches of Hadrian and Marcus Aurelius. The vast Colosseum became a quarry for Renaissance and Baroque architects, and great blocks of its marble went to build palaces and St. Peter's Basilica.

"Our buildings," the Romans say, "are all cousins."

The Rome of today also takes in much of



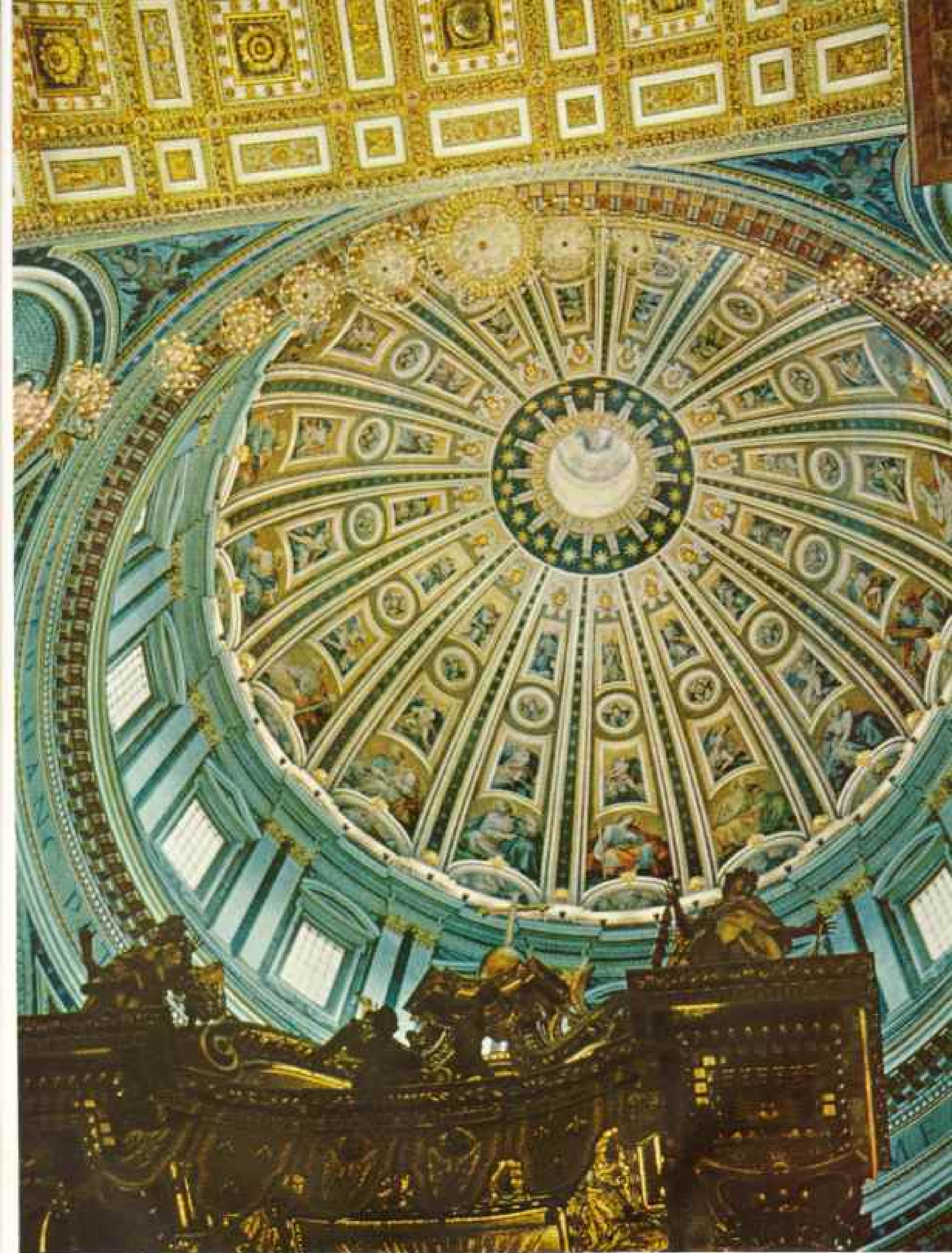

### St. Peter's Dome of Gilt and Mosaic Soars 435 Feet Above the Apostle's Tomb

For centuries the treasure of the Vatican and the genius of Renaissance and Baroque masters poured into this tremendous sanctuary. Wherever the eye turns it is dazzled by marble, alabaster, bronze, and mosaics so delicate they seem painted. Michelangelo designed the dome, whose 16 panels portray Jesus, the Virgin, apostles, and saints.

← Page 462: Christ and apostles stand on the roof. Upper windows hold loudspeakers to carry the Pope's words.



## Michelangelo's Heroic Frescoes Swirl Across the Sistine Ceiling

Page 465: The private chapel of the Popes takes its name, Sistine, from Pope Sixtus IV, who commissioned it in the 15th century. A relatively plain building without, it contains unparalleled masterpieces of Renaissance art.

Most notable are the ceiling frescoes that Michelangelo painted at the demand of Pope Julius II. The Florentine genius spent more than four years on the project, working alone. Lying on scaffolding or sitting in painfully cramped positions, he painted with feverish speed to apply his pigments to each section of wet plaster before it dried. Despite misery, illness, and rivals' intrigues, he covered some 10,000 square feet with what many experts consider man's greatest single-handed work of art.

Nine central panels tell the stories of Genesis from the Creation to the Flood. Three panels here shown in color depict the creation of woman (below), Adam and Eve's temptation and expulsion from the Garden, and Noah's sacrifice after the Flood.

Altogether, the masterpiece is peopled by 343 figures, many of them titanic creations of the imagination. No two are alike. Some of the nudes are deemed the finest portrayals of the human figure—evidence of Michelangelo's consummate knowledge of anatomy.

← Twenty-three years after finishing the ceiling, Michelangelo returned to paint 300 figures of *The Last Judgment* on the chapel's altar wall.

At each Pope's death, the College of Cardinals meets in this chapel to elect a successor.

© National Geographic Society

the latest in modern influence. With each stay I discovered more neon signs, snack bars, and Dixieland jazz bands. Certain young Romans go about in blue jeans, trying to look like Marlon Brando.

Such sights make the older generation shake their heads. But a white-haired *contessa* appeared undismayed.

"You'll find a lot of things that weren't here a few years ago," she told me. "Don't be fooled. A great many people thought

they were changing Rome to their taste—the Germans, the French. They came but we conquered. We took a bit from each, when we wished it, and that was all. Come back again in 25 years and you'll see that Rome is still herself."

Against a background of ancient glory and glossy modernism, I relearned the mixture of routine and spontaneity, of strict rules and easy nonchalance which characterizes Roman daily life.





For all but a few, the day starts early. Each morning I would find myself in one of the town's hundreds of *caffè espresso* bars, where coffee-making monsters of chromium, all spigots and shine, give forth a rich brown-black brew, aromatic and potent (page 472).

Thus the Roman begins his day with his interest in life well keyed up. He talks to the coffee dispenser, his friends, and the stranger next to him. His topics are the government situation, what the Vatican said today, a rumor about an eccentric *marchese*. Then, sighing because he must leave his friends, the Roman goes on to work.

If the distance is not too great, he will walk and save a few lire. He will look neat, his clothes pressed

(Continued on page 471)

466

← High on St. Peter's,  
Pope Pius XII Speaks  
an Easter Message

From the Balcony of the Benedictions, above the basilica's enormous entrance, the pontiff addresses a third of a million Romans and pilgrims thronging St. Peter's Square. His personal coat of arms hangs below.

Page 467

A Roman Multitude →  
Packs St. Peter's

Concealed beneath the mighty canopy in foreground, the Pope says Mass at the papal altar during the ceremony of canonizing a new saint. Light gleams from 800 crystal chandeliers.

Swiss Guards stand at attention before the altar, Noble Guards cluster beyond, and Palatine Guards line the open aisle of the nave. White-surpliced clergymen fill the front rows. Diplomats and noblemen share the loges. Some 70,000 ticket holders fill the church, overflowing into side aisles.

Photograph seems to shorten the church, which extends almost an eighth of a mile.

Three Lions, Leonard Van Matt ←







### Vatican Library, a Festival for the Eyes, Appears More Museum than Book Repository

Cabinets beneath the ornate pillars and walls encase the world's richest collection of manuscripts and incunabula (books printed before 1501). Scholars come from afar to study these rare documents, numbering some 67,000 and dating from the fourth century. Modern books—secondary items here—are shelved below the hall.



### Costly Gifts from Prince and Potentate Line the Library's Great Hall

Most of the decorations glorify literature or exalt the pontificate of Pope Sixtus V, who ordered the gallery built. More than 10 million microfilmed pages from the library's most valuable documents on philosophy, law, and history were recently placed in St. Louis University (Missouri). American contributions financed this prodigious job.

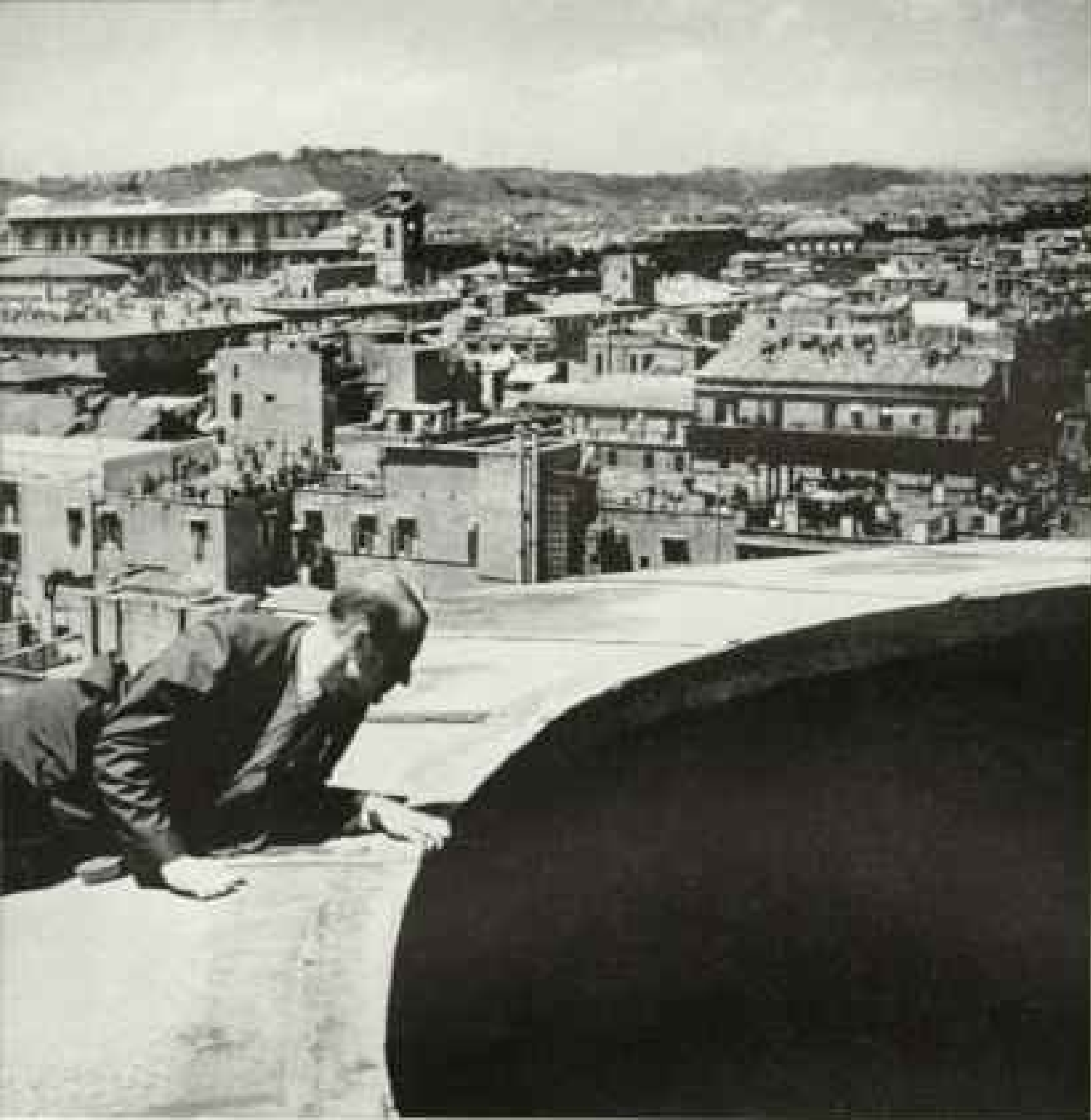

470

## Ancient Rome's Best→ Preserved Monument Is the Pantheon

Use of concrete was virtually forgotten from the fall of Rome until the 18th century. Its secret was well known to the Romans, whose brilliant engineers developed concrete from volcanic deposits and used it for the frameworks of their many architectural triumphs.

The Pantheon's builders used concrete along with brick in both walls and dome. The sloping roof now wears lead sheathing.

Bronze plates that once adorned the structure were stripped away by Pope Urban VIII of the Barberini family. He used them in the canopy over the high altar of St. Peter's and in cannon to protect the Castel Sant' Angelo (page 474). Romans remember the event thus: "*Quod non fecerunt barbari, fecerunt Barberini*" (What the barbarians did not do, the Barberini did).

Despite its losses, the Pantheon is still impressive for perfection of form and sense of restful space. Its height is exactly the diameter of the dome—142 feet.

Farmers on weekdays gather around the obelisk-tipped fountain, for the square is a produce exchange and an open-air hiring hall for field hands.

### ↑ Sun and Rain Beat Through the Pantheon's Open Eye

This temple to the gods of the seven planets was built by the Consul Agrippa in the first century B. C. (see inscription, opposite) and rebuilt by Emperor Hadrian following a fire. Now the Church of St. Mary of Martyrs, it is the tomb of Raphael and of united Italy's first two kings. Wagonloads of bones from the catacombs once rested there.

↓ Noonday sun throws a fierce spotlight on the Pantheon floor. Despite apparent darkness, the windowless rotunda is amply lighted by its lofty, 30-foot eye. A sloping floor carries rainwater to drains.

Walter Moore Edwards, National Geographic Staff





and his shoes polished. One of my neighbors started daily for his office clerk's job in dapper style, brief case in hand, hair slicked. Only after a month did a fellow boarder explain: "Nino has one business suit and two pair of pants, and he spends 20 minutes a morning at his pressing. That brief case? It has his sandwich and a little bottle of wine."

The Roman male wishes above all to dress conservatively. His tie must be precisely so, his cuffs exactly right. He wears his snug, short-coated suit with a dignity approaching hauteur, and it is no secret that he cares far more about his appearance than the American or Briton. He shaves with loving care. He may wear a hair net overnight, so that his hair won't be too unruly when he labors at his hair part in the morning.

Softly beautiful Roman girls in twos and threes emerge from their homes after struggling over their "dress" costume; the material may be inexpensive, but the cut will probably be superlative. They have also worked long at their dark, magnificent hair.

From my friend Salvatore I quickly received a lesson in the importance of the looks of things. Meeting him, I saw his eyes go to my shoes. "They were shined yesterday," I said.

"People will know it wasn't today."

"Appearances aren't everything."

"In Rome they are, practically." By then he had steered me to a shoeshine man on the Piazza Colonna.

#### Every Buyer a Bargainer

Like other early-morning Romans, I often passed stalls or wagons along the narrow streets. To the newcomer Italian produce looks uniformly superb, picked at precisely the best moment. Ripe gold oranges, tomatoes of a rich redness, apples, and other fruit are tied together with grapevine and displayed with a flair.

Once more, style matters. But no matter how good the display looks, purchasers rummage, pinching, squeezing. "No, no, not those. They aren't worth half the price."



© National Geographic Society

472

♣ *Caffè Espresso*, Rome's Favorite Drink,  
Trickles out of a Shiny Machine

Steam forced through measured amounts of coffee condenses slowly until it fills each tiny cup. Here Leonard Lyons, American columnist, and his wife (center) join two actresses at the coffee bar of the Hotel Excelsior.

♣ "Just Feel the Material, Signora!"  
Italy Displays Its Silks with Pride

Tiny, exquisite shops line fashionable Via Condotti. One is "Arbiter—Son and Man," noted for its fine stock of silk wares for men. Patterns often copy the designs of Italy's master artists. Manufacture of neckties is one of Rome's few industries.



"Signora, you are mad. My children would starve if I gave them away as you want it." A few more exchanges, then "*Basta, basta*" (enough, enough)—and the deal is settled.

Once at work, the Romans remain until about noon or 1 p. m., when everything shuts and stays shut until 4 p. m. To move about Rome during the next few hours is to see deserted streets, and cars and buses almost empty.

Anyone who can get home does so; others amble toward their favorite small restaurant, or *trattoria*, or to a still smaller one, a *vasticceria*, where everyone eats standing up. Most Romans, however, expect to sit down for a full meal, and with it goes a bottle of *vino rosso* or *vino bianco*.

### Conversation Spices the Food

This midday dinner is a restful yet voluble occasion. Everybody is here to savor one of life's primary pleasures, and also to enjoy the company of friends. The meal starts with the ritual words, "*Buon appetito.*" The waiter murmurs it, or a man's friends, and each says it as if he means it. After the big midday meal comes the siesta.

In the evenings I frequently went to the well-publicized Roman establishments, but for lunch I sought out a smaller, less pretentious place. And, as in Paris, the cooking at the latter would often surpass that of the celebrated restaurants.

Seldom did I come upon anything ready-prepared; dishes are boiled, broiled, or baked while the customers relax.

In the kitchen cooks and helpers scurry between hills of meat and bits of fowl; eggplants simmer in butter, and tomatoes are macerated with care. The Italian takes few short cuts; cooking requires time and attention, and he expects to give it both. Always within reach, of course, is oil from Italian olives, the vital ingredient. Though confusion seems the rule, the dishes go steadily out and come steadily back, usually well emptied. The last bit of sauce or soup is wiped up with bread.

At hand in most restaurants is a vital piece of equipment, a talcum shaker. When an Italian spills something on himself, he signals and the waiter brings the shaker on the run. Then both work in a fury. Part of their purpose is to avoid a cleaning bill; but part of it, surely, is to keep up that good appearance no matter what happens.

The owners of small restaurants take an interest in the customer. I dawdled over lunch one day. Three of the proprietor's family approached in turn: Was the food not good today? I said I had a headache. What kind of headache? And so on.

I learned to expect interruptions while talking with friends in modest restaurants. A small boy or a nun would enter, holding out a hand in silent appeal. A man would pass with cigarettes, another with a tray holding sun glasses, a third with belts or ties or big dolls that walked. Generally such offerings were rejected, after a bit of bargaining, but seldom brusquely. Peddlers have to live too, *signore*.

By 4 p. m. offices and businesses reopen, and Rome settles down to work again. At such times I liked to walk about the smaller streets, listening to the buzz and clank of artisans and workmen who make up most of Rome's labor force: furniture makers, carvers, shoemakers, each with only one or two helpers. For generations such men have developed their Italian skills, their instinct for the good line, their adroit hand with wood and leather, ivory and marble.

Knowing them better, I discovered how these average Romans manage their affairs and finances. The biggest factor in their calculations, in their hourly thoughts, is the family.

### Romans Cherish Family Ties

The Roman and his wife and children are far from alone in their world. They have brothers and sisters down the street, the old mother in the same apartment, cousins in the country. Possibly they have with them a child with no legal claim on them; out of generosity Romans frequently care for a waif. In the clan all have responsibilities. To refuse help to a cousin or to turn away an uncle would be unnatural, a thing to cause heart-break and also bad luck.

Relatives and friends go in and out; from the Campagna comes one, then another, to hunt work in Rome or to make a business deal. This helps all around; a nephew with a part-time job has a roof over him, and his contribution helps the family budget while he stays. In one case I met what seemed to be a family of six living in three rooms. At dusk, however, eight or nine others arrived for the night, and in each room several slept on pallets or on the floor.

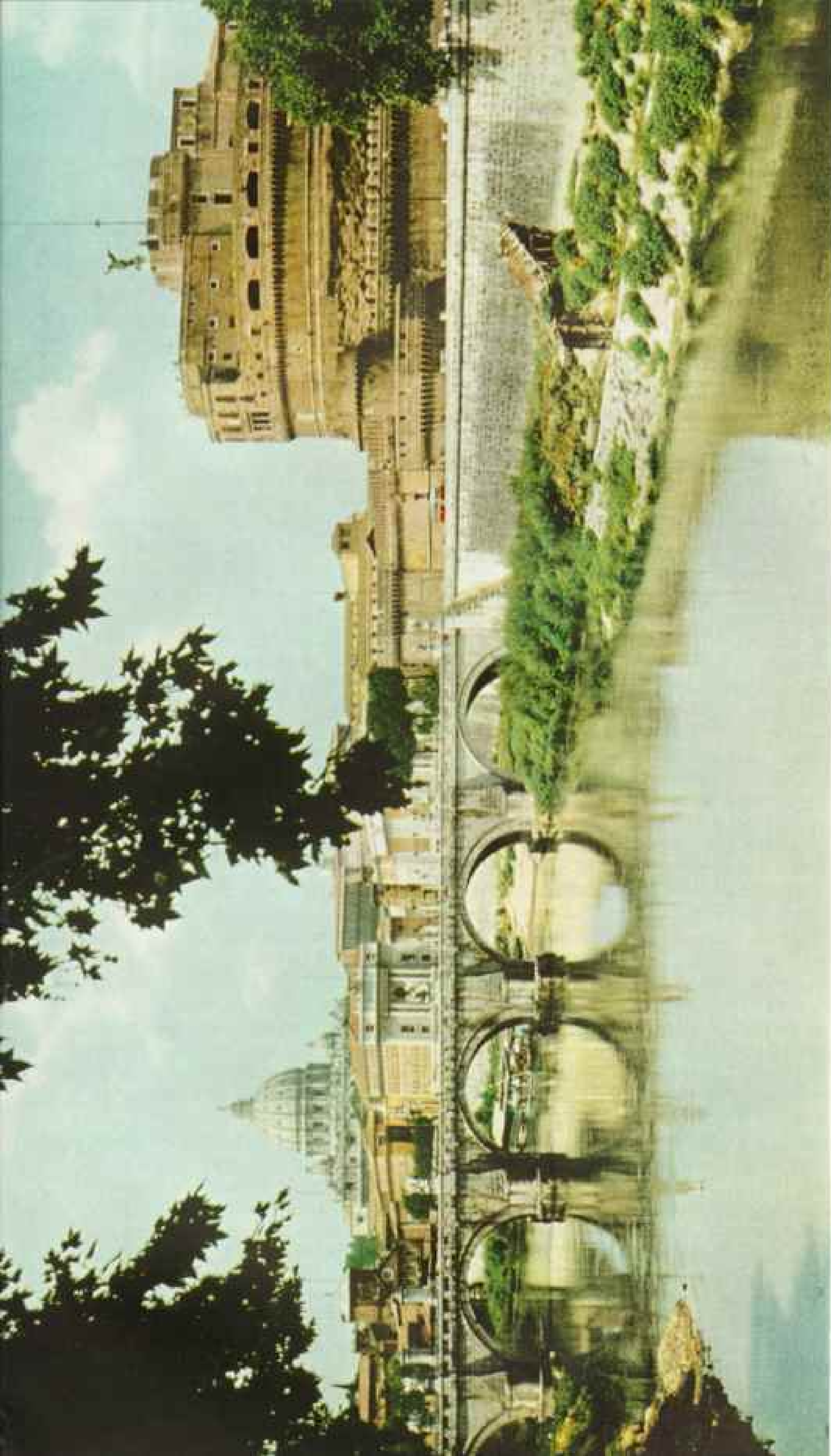

↑ **Stone Walls Restrain Father Tiber, Once the Scourge of Rome**

The tawny river, Italy's largest after the Po, winds peacefully under the ancient Pons Ælius and past the circular walls of Castel Sant' Angelo (right). St. Peter's dome, visible from almost any point in the city, rises beyond.

↓ **Grim and Battle-Scarred Stand the Walls of Hadrian's Tomb**

Now a museum called Castel Sant' Angelo, the emperor's tomb served for centuries as a fortress. Its decorative statues were hurled down on besieging Goths. Barbarian invaders scattered Hadrian's ashes on the Tiber.

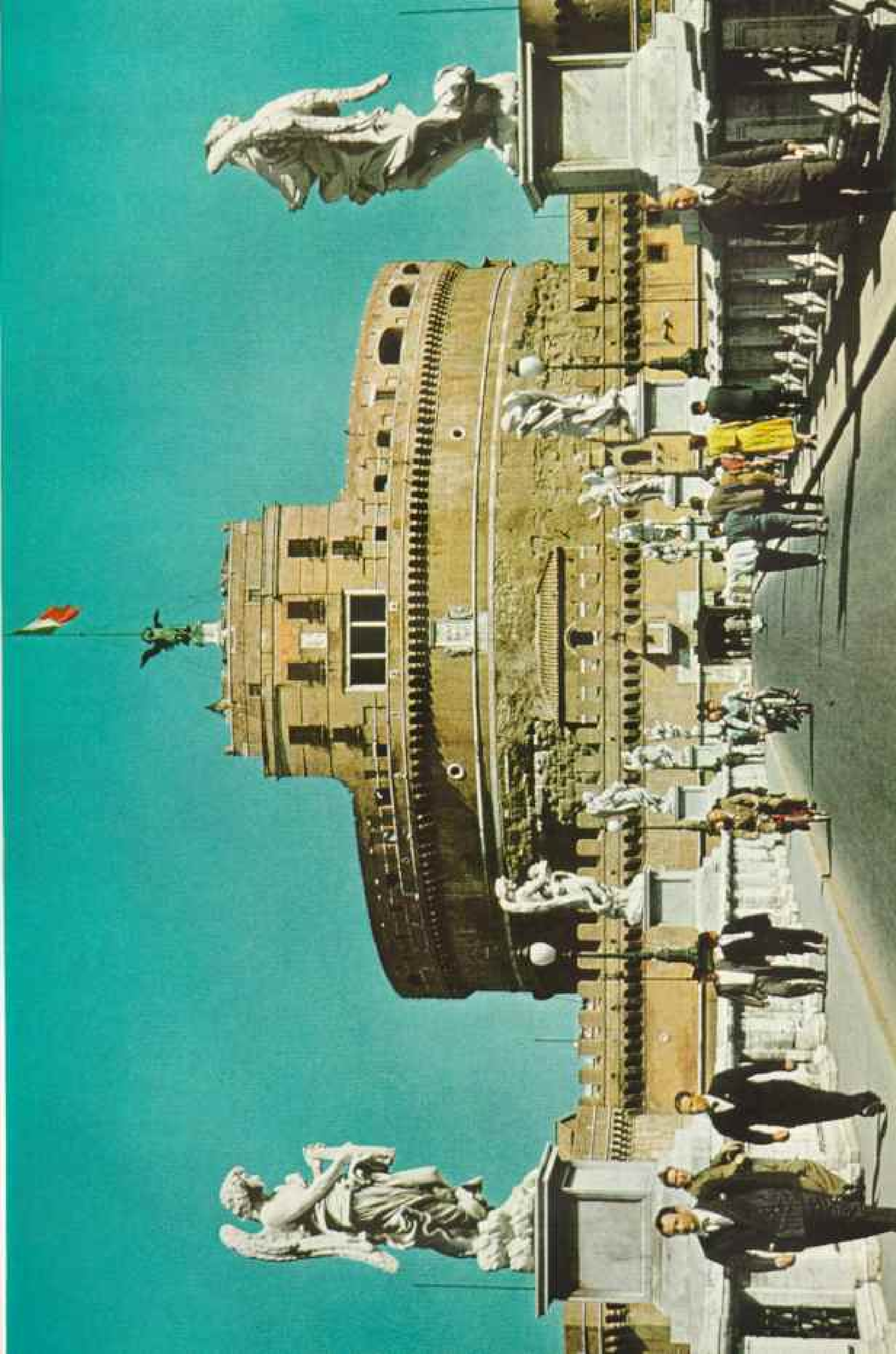



The salary of the head of the house often cannot support the family. He must stretch and cut corners everywhere.

The wife of one such man whom I knew bought nothing that was not in season, and not before she had made certain that the price had reached its lowest level. When her husband had to buy or fix something, he had relatives in five stores to advise him.

"Come back next week for the meat; we're having a sale then. . . ." "If you have to have a clock, try Monday. Everything goes down on the first. . . ." When his suit became too shabby, he received a tailor's special rate for a new one, because his sister worked in a store that sold buttons to this tailor at a discount.

Most Romans pay more for their clothes in proportion to income than do Americans, but they make them last longer. Even so, they cannot afford the expensive shops or even the few stores selling ready-made clothes. They patronize the *piccolo* (little) tailor and dressmaker. The scale of all their living is *piccolo*, a series of *piccolo* savings.

Almost nothing is thrown away—wrapping paper, aluminum paper, string. About to toss away a paper box, I was halted by a housewife. "*Prego* (please). We can use it."

Often a man will buy only three or six cigarettes at a time. His wife purchases in tiny lots too—a few pieces of fruit, a quarter pound of something, enough for a meal at a time. Twenty lire saved here, 50 there; so the Romans live.

Usually there is no money for larger purchases. If there is, the wife will still hesitate. A family crisis, an accident, or a relative in trouble could throw everything out of calculation. As it is, the family generally ends the month with a financial struggle. At many shops the employees borrow from each other, and the first of the month brings a general settling of accounts, 150 lire to Mimmo, 300 to Paolo. . . .

Nevertheless, there is little gloominess whenever three or more Romans gather. They shrug, smile, lift eyebrows and communicate by a system of gestures that appears

(Continued on page 481)

#### A She-wolf in Etruscan Bronze Suckles Rome's Legendary Founders, Romulus and Remus

That a wolf mothered the castaway twins was popularly believed by the ancients. To this day she remains the city's symbol. This statue stands in the city hall on Capitoline Hill. An Etruscan sculptor of the fifth century B. C. created the animal. Antonio Pollaiuolo added the twins in the 1400's.





**A Painted Hadrian Wears the Beard** Tradition says he grew to cover a facial blemish. The emperor supervised construction of his tomb (page 474). Interior decorations were painted during the Renaissance.



**A Soccer Ball Flies High in the Air Beside 1,900-year-old Arches of the Aqueduct of Claudius**

Eleven aqueducts brought spring water from the hills in incredible quantities; ancient Rome enjoyed a larger water supply than the modern city. Some of the conduits remain in use. Even those in ruins excite admiration for the builders.

### Low-cost Apartments on the City's Outskirts Rub Shoulders with Gaunt and Lonely Ruins

In some areas extensive excavations have uncovered magnificent temples and forums. Elsewhere the Rome of the Caesars lies 20 feet and more underground. Occasionally broken columns and crumbling walls protrude above the surface, as here in the Via Tuscolana area.

479

© SoDimit, Contrasto/Alinari





← **Rare Is the Roman Balcony  
Without a Splash of Color**

Jasmine, lemon, rose, oleander, and pine make a garden of this rooftop. The tenant, an English actress and poet named Iris Tree, lives in the tiny seventh-story penthouse. A short distance away, in the Piazza di Spagna, stands the onetime home of poet John Keats (page 441).

complicated but is basically simple: thumb to cheek, finger against nose, hand against stomach—each has its significance. A meaningful stare, a guffaw, and worries seem to be gone. "When things happen we let them happen," a Roman told me. "We yell and hit something; then *va bene*" (it's all right).

In late afternoon or after work, Romans look forward to the *parseggiata*, a leisurely promenade to see what the rest of Rome is doing. In the city's center, passers-by pack the sidewalk, dividing by common consent so that half go in one direction and half in the other. Those who do not wish to promenade sit sipping ices and watching.

Walking or sitting, the men talk of politics and tell the latest jokes. As often as not they talk about the ladies. At the approach of a pretty girl the group comes to instantaneous attention. Eyes bulge, hands stop in mid-air, and approval is vocal. The passing girl is aware of it all, of course, but she is not offended. She is impressed with the men's good judgment.

Eventually the Roman goes home, and now the family envelops him. Everybody scrambles for greetings, questions, kisses. Children are petted and encouraged; in few places do the young receive such attention and warming affection. And the Roman family does not break into units as might an American one—the old people here, the youngsters over there. All sit together. Grandmother and Grandfather show great interest in the conversation, and so do the seven- and eight-year-olds. There are few reticences. Everyone shares in everyone else's concern, and everybody talks on, loudly, zestfully, with fire.

Page 480

← **Novella Parigini Dabbles in the Bizarre  
at Her Via Margutta Studio**

Rome's art colony, larger than that of Paris, overflows the narrow Via Margutta in a section notable for centuries-old flavor. Studio windows overlook hidden courtyards and gardens and gather in the bright Italian light so prized by artists.

"It is not so."

"I say it is!"

At such times I have feared violent outbursts. But a moment later everyone will be laughing. Papa speaks most, yet nobody can doubt that things revolve around Mamma—the cook, manager and planner, and the center of love for Papa, the children, the relatives.

Above all, Romans are seldom bored. They have, more than anything else, an eager interest in the doings of people around them, their achievements, their failings, their health, their fights with the neighbors. Births, deaths, marriages, crises emotional and financial, all are grist to the Roman mill.

There are few secrets in a neighborhood, be it in the sunny Parioli district of fashionable apartments or the dimmest alley of the Trastevere tenement district. A window is to be looked through; a footstep is to be heard.

"All this is life," the Roman smiles. "Why shouldn't we be interested?" That people everywhere can also become interested is proved by the world-wide artistic success of Italian films which focus on the penny-saving, emotion-charged life of the average Roman.

**Best Businessman Wins the Girl**

I concluded that the Roman, for all his romantic feelings, is a practical fellow at heart. Despite all his talk of *amore*, he does not quite believe in a world well lost for it. He expects his marriage to continue no matter what. "And we do not wish our young to jump into marriage without considering everything," I was told. "You Americans do that. *You* are the romantics."

I remembered this remark as I witnessed a five-week family crisis. Anna, 21, felt strongly for Carlo, 24. Whenever I saw them Carlo hardly let his eyes leave Anna. But Carlo had work for only a few hours a day; there was another suitor, an older man with a thriving shop a few squares off.

I watched Anna sigh, Mamma and the aunts debate, and Papa turn glum. Talking about this with someone else, I said that Anna would surely take handsome young Carlo.

"That shows you're not an Italian," he frowned. "She'd be crazy to pass up somebody with a good shop. It wouldn't be right, or fair to her family. You'll see."

I saw. Anna told Carlo goodbye and for days she went about with a sad face. Then she smiled again; the other suitor turned up





483

### With Sabers Drawn, *Carabinieri* Charge off the Parade Ground

Most highly respected of Italy's police groups are the Carabinieri. For nearly a century and a half their swallow-tailed coats, tricorne hats, and red-and-white cockades have symbolized law and order on the peninsula.

Italians call the Carabinieri *I Fratelli Bianca*, meaning the Catch Brothers, because they patrol in pairs and "always get their man."

These military police number some 70,000. Members are chosen according to the most rigid standards of physique and character. An erring grandfather is enough to disqualify a candidate.

Originally a mounted corps, the Carabinieri still stick largely to the saddle when fighting in battle or patrolling country districts.

Here the Pastrengo Barracks Squadron rehearses for Rome's International Horse Show.

← Page 482: Lt. Col. Eugenio Unali leads his group in precision maneuvers.

→ His uniform reflects the magnificence of Napoleon's day, when the corps was organized.

© National Geographic Society





several times at the house, and before long the wedding was set.

Meanwhile, as ever, there is the Church. It is hardly possible to walk in any direction in Rome without finding a place of worship: two or three may rise in the same block, around the same wide piazza. On any street the stranger may meet a nun walking alone or with a child, or a solemn young seminarian, or a bareheaded, sandaled monk carrying his brief case like any other Roman.

### St. Peter's Dome Crowns Vatican City

The heart of Catholicism is a sun-swept rise west of the Tiber, beyond the range of the long-fabled seven. Here rises St. Peter's, with the ornamented dome that dominates Rome in more ways than one (page 438). Beside it lies Vatican City, since 1929 once more a sovereign state, but now shrunk to a walled-in area of less than 110 acres. To it many nations send accredited representatives. Thus Rome has two diplomatic centers, two diplomatic sets and societies: the Government and the Vatican. One is no less official than the other, and of the two, the Vatican stands far more on ceremony.\*

Within this narrow circuit are the largest church on earth and a cluster of palaces, chapels, galleries, apartments, courtyards, barracks, passageways, and secluded gardens. Some count 1,000 rooms in the Papal Palace; others claim that figure is too small. Inside the walls is a mass of man's great works of art, ageless treasures on canvas, in gold and marble, in books and architecture.

Rome stops abruptly at the edges of Vatican City. Inside live about a thousand men and women, with their own flag, their own currency and postage stamps, shops, small industries, a newspaper, a powerful radio station, and a tiny railroad; not least, their own police, of several varieties, one with rules and costumes dating back to the Renaissance.

Vatican Hill has deep significance in the Christian story. At its foot was the Circus where Nero grinned over the agonies of the martyrs. A year before Nero's death, according to tradition, Peter the Apostle was crucified upside down, and his followers buried him along the old Circus wall.

Within a quarter century a small oratory marked the spot. Eventually, between 315 and 335, the Christian Emperor Constantine erected the first basilica in Peter's name.

Through the years the basilica deteriorated,

until a 15th-century Pope declared it hazardous and inadequate and decided to replace it. Artists and builders made great new plans, remade them, saw them rejected, expanded. The monumental church emerged bit by bit as one Pope after another urged creative men to work to their capacities. Raphael, Bramante, Peruzzi, Sangallo the Younger, Maderna. . . Each had his commission; each died with his part in St. Peter's or the adjoining Vatican buildings unfinished or barely finished. Construction went on for more than a century, but in a sense it still has not ended.

In 1626 Urban VIII consecrated this majestic work, impressive above all in its proportions, in the subjection of sheer size to plan. Flaws reveal themselves; the front, for instance, is raised so high that Michelangelo's great dome cannot be seen in its entirety unless the viewer is far away. Some think the great pile a bit cold. Yet the vast harmonious whole makes its effect (page 462).

In recent years hundreds of medieval houses have been cleared for a new widened approach, the Via della Conciliazione. In front of the basilica itself opens the Piazza San Pietro, the work of Bernini, king of the Baroque; few would deny that this is one of

\* See "The Smallest State in the World," by W. Coleman Nevils, NATIONAL GEOGRAPHIC MAGAZINE, March, 1939.

Page 485

### Marble Pluto Carries Off Proserpina → to Be Queen of the Nether World

The ancients explained the miracle of the seasons by the legend of Proserpina, daughter of Ceres, goddess of the earth. Spring reigned eternal until Pluto, god of the dead, saw her gathering flowers and abducted her for his bride.

Mother Ceres searched the world over for her daughter. In sorrow and anger she cursed the earth. Plants and animals died, and men would have starved had not Jupiter persuaded Pluto to let Proserpina spend half of each year with her mother.

Thus, according to the legend, spring and new growth come with Proserpina's return; autumn and death mark her descent to Hades.

Rome's Borghese Gallery displays this famous 17th-century work. Three-headed Cerberus, guardian of Hades, barks at his master's feet.

Giovanni Lorenzo Bernini, the sculptor, showed unusual skill in turning marble into flesh; Pluto's fingers make realistic indentations. Bernini's craftsmanship earned the patronage of six Popes; churches and fountains all over Rome bear his mark. The colonnade around St. Peter's Square is his work (page 439).

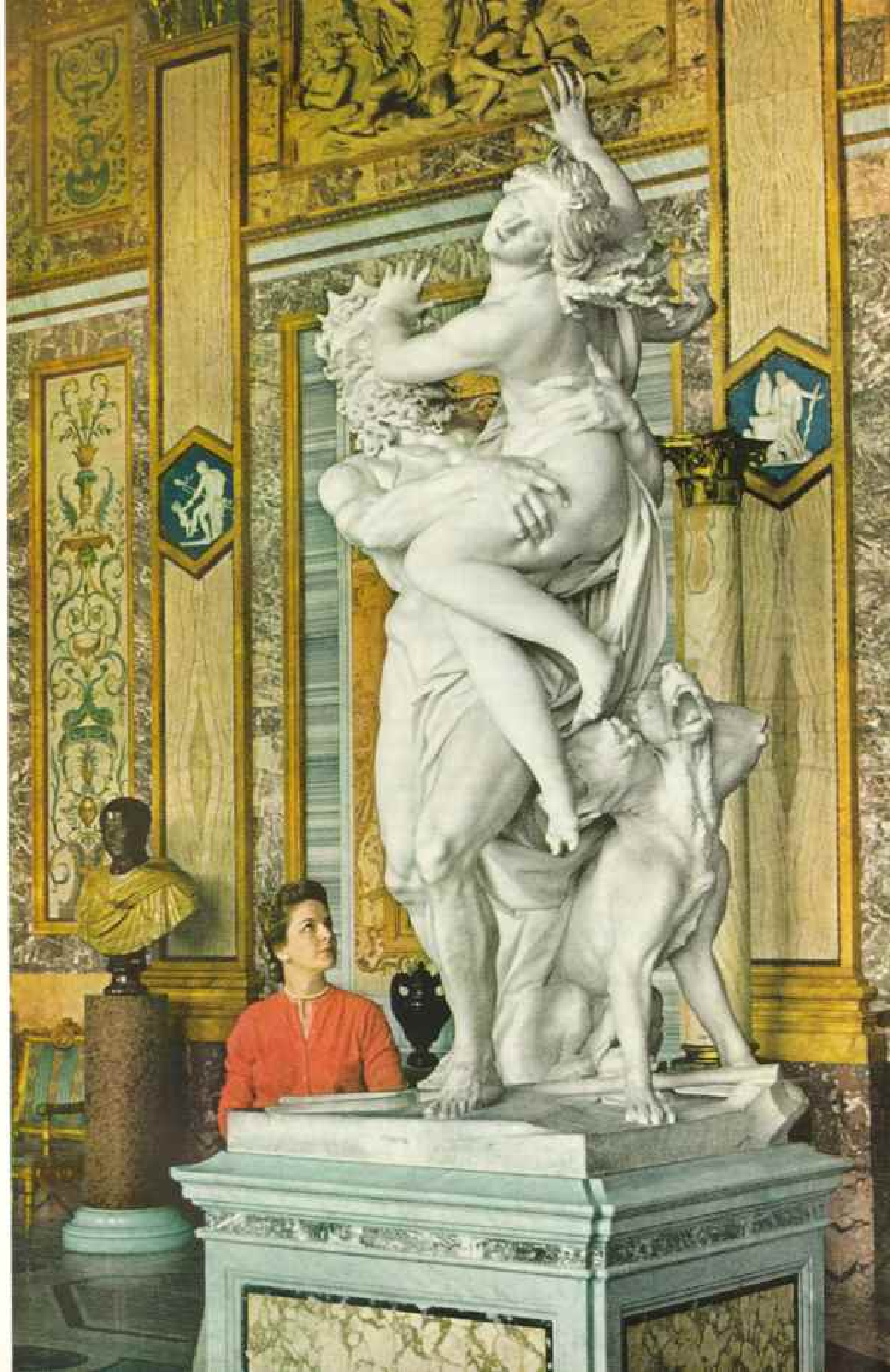

the most magnificent squares of the Western world. In 11 years Bernini fashioned a great curving line of powerful quadruple columns, reaching out like two arms in an almost closed ellipse (page 439).

On the balustrades atop the colonnade and at the roof line of St. Peter's stand some 150 statues of Christ, apostles, and saints. In the enormous square rise two fountains of rare grace and simplicity, and between them towers an obelisk that Caligula brought from Heliopolis, near Alexandria in Egypt. Once it rested about 1,000 feet away in his Circus, later called the Circus of Nero. Many Christians died around it.

#### Moving the Immovable Obelisk

Legend says the Renaissance Pope Sixtus V ordered it moved, despite advice that the job was impossible. A thousand workmen and scores of horses struggled with beams, ropes, and scaffolding until the ponderous object was lifted and teetered perilously in air.

Sixtus had ordered silence, under penalty of death, so that his engineers would not be distracted. But a sailor, seeing some of the ropes stretching, disobeyed the order and shouted the remedy: "Water on the ropes!" Workmen complied, the ropes shrank, the job was completed, and the sailor was rewarded instead of being executed.

Across the piazza a flight of stairs leads to St. Peter's portico. Five wide doors open to the interior. Stepping through any of them, the returning visitor is almost certain to halt at the splendor, no matter how often he has seen it: The white-gold majesty of the lines of columns, the monuments and marble figures, nearly 30 altars and chapels, the four wide aisles and the nave stretching ahead about an eighth of a mile (page 467).

Slowly the stranger moves about the effigies, the altars, the massive cherubs, the bronze statue of St. Peter with its foot rubbed smooth by fingers and lips of the devout. He goes to the high altar, where only the Pope may say Mass. Its canopy is held aloft by four spiral bronze columns, and long shafts of light pour on it through amber windows.

The stranger can ride the elevator to the roof, with Michelangelo's dome soaring above him there, and climb high to the ball above for a celebrated view of Rome spreading on all sides. He may also enter crypts and ancient passages below, and the Vatican grottoes holding historical treasures.

At the end he may remember longest a white statue of a woman who holds in her arms the limp body of her son. This is the *Pietà* of Michelangelo, the Sorrowing Madonna and the Christ, endowed with ageless glory.

A short way off waits the entrance to the Vatican museums, with a double spiral stairway. It was finished only in the 1930's. Along it a procession of hundreds may throng up while another goes downward. Above begin the works of art. Here are the Sistine Chapel, the Borgia apartments, Raphael's Loggia, the Egyptian Museum, the Vatican Library (pages 468-469), and the Pinacoteca, an impressive expanse of rare paintings.

The caller will halt at the Apollo Belvedere, the writhing Laocoön group, and others he has seen in reproductions. He will go through rooms designed by Raphael and stare at works of Da Vinci, Titian, and Fra Angelico. But he will linger longest in the radiance of Michelangelo's work in the Sistine Chapel, craning his neck toward the unrivaled ceiling frescoes that show the world's creation, man's fall, and man's hope (pages 464, 465).

He may remember that Michelangelo, until then primarily a sculptor, did not seek this overpowering assignment. His jealous rival Bramante allegedly persuaded the Pope to commission it, believing that Michelangelo would fail. Ordered to do it over his own protests, Michelangelo set to work to learn to paint in fresco.

#### The Ordeal of Michelangelo

The project took four years of agonizing labor, during which Michelangelo lived for long periods on scaffolds, working in strange positions, frequently in pain. At one point he wrote: "My stomach points toward my chin, my beard turns toward the sky, my skull rests on my back."

He knew troubles of other kinds; the Pope's master of ceremonies criticized his work and Michelangelo got revenge by presenting his enemy's features as the face of Minos, judge of hell.

Twenty-three years later, he returned to paint a gigantic mural of *The Last Judgment* on the chapel wall, showing Christ flanked by martyrs. Among them is St. Bartholomew, who was flayed alive. He holds his own skin on which appears a distorted face—that of Michelangelo himself.



### Where Lions Fought, the Colosseum's Homeless Cats Beg for a Handout

Rome's animal is the cat. Hundreds haunt the city's antiquities, especially the Forum and the Pantheon.

When he finished, Michelangelo had achieved one of the wonders of all time. And upon this chapel there centers at times the interest of a world, for in it the College of Cardinals meets when a Pope must be elected. Thousands wait outside, watching

for the sign of agreement—thin smoke silently eddying toward the sky as the ballots are burned.

Here is a busy world. In mosaic studios, artisans struggle year after year on reproductions of religious works. Elsewhere nuns

### Napoleon's Sister Modeled for Canova's Statue of Venus

One of Rome's finest art collections fills the Borghese Gallery, a magnificent 17th-century villa on the Pincian Hill. The Borghese collection would have been even larger had not Napoleon carted off some of the best items to the Louvre in Paris.

Prince Camillo, one of the Borgheses, married Pauline Bonaparte. Here Pauline is preserved in marble as Venus Victrix, who holds the golden apple that signified her triumph in a beauty contest involving Minerva and Juno.

The artist, Antonio Canova, came from a family of stonemasons. While a lad he worked as a waiter in a *canova di vino*, or wine shop, from which he took his name. A lion he carved in butter caught the attention of a wealthy diner. Fame and fortune quickly followed.



488



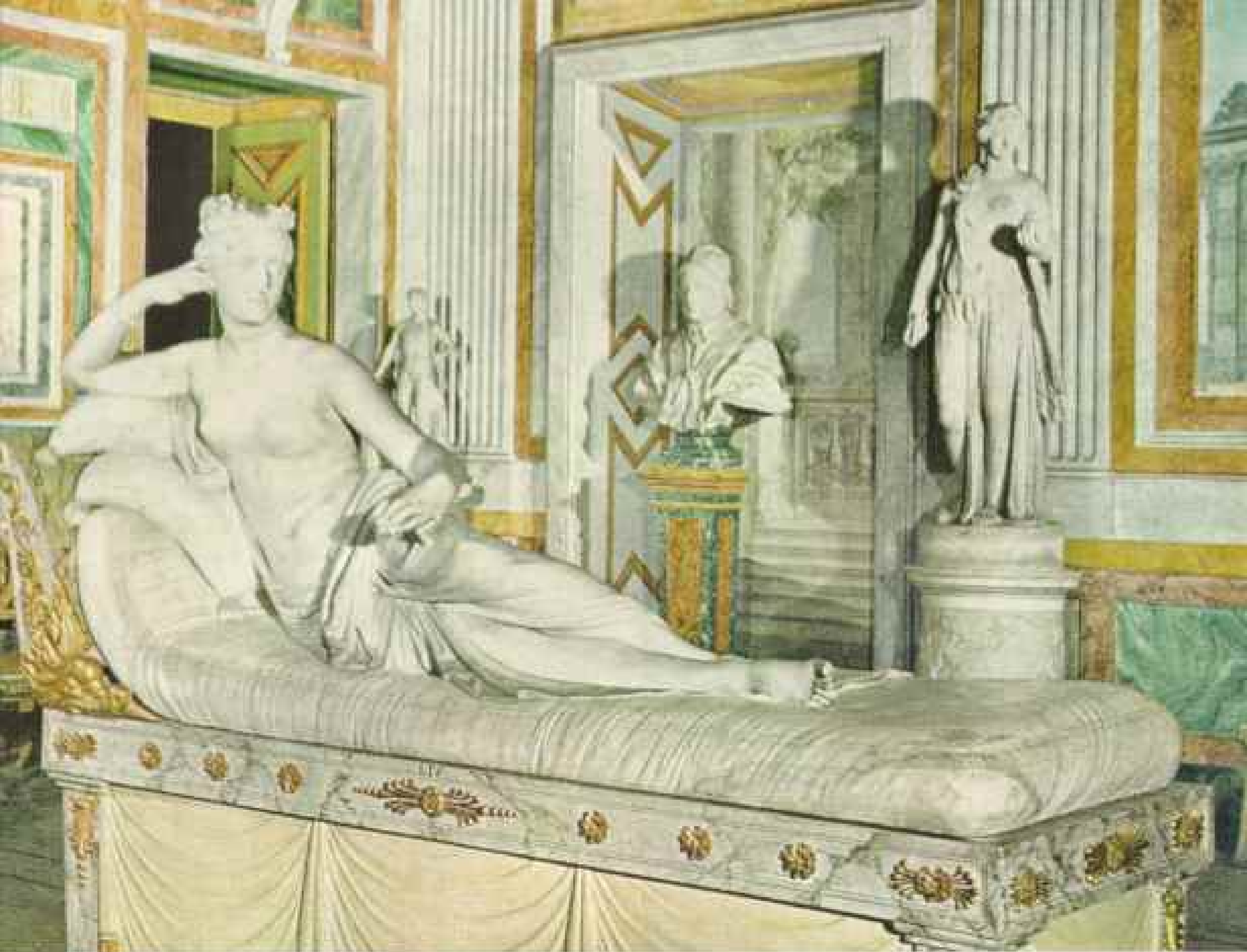

### No One Knows What Titian Meant When He Painted "Sacred and Profane Love"

This exquisite allegory is a gem of the Borghese Gallery, now owned by the people of Rome.

Titian, one of the finest and most prolific of the Renaissance masters, painted the scene about 1515, early in his long career.

The Aurella family commissioned the work, and their coat of arms decorates the sarcophagus on which the figures rest.

Numerous interpretations have been applied to the painting. Some think it represents Venus persuading Helen to listen to Paris. Others believe it to be Helen inducing Medea to follow Jason. Regardless of meaning, it is distinguished by luminous color and serene beauty.

"Peep Through This Keyhole  
—You're in for a Surprise!" →

So says the guide when he brings visitors up the Aventine Hill to this heavy gray door at the entrance to the headquarters of the Knights of Malta.

← To the astonished delight of each viewer, the brass-bound peephole frames the dome of St. Peter's. The soaring landmark, more than two miles away, floats like a cameo in the exact center of a garden archway of bay trees.

Here the telephoto lens—looking through the peephole—brings the dome up close.

Zurich and Lucerne in the German-speaking region of Switzerland agreed to provide the Swiss Guards. Their well-known garb is yellow, red, and blue; on great occasions they wear steel cuirasses, ruffs, and helmets and carry halberds eight feet high. Their quarters are a little island of Teutonic Switzerland in an Italian sea, with German food and heavy steins of beer.

In this place of tradition unaltered, Pope Pius XII has made history during the crowded years since his elevation in March, 1939. To see him over a period of several years, as I have, is to behold a man whose face reflects a vast simplicity, and with it a rare vitality of mind and spirit.

Whatever one's religion, a papal audience can be a memorable experience.

There is a wait, and then a signal; the lean figure slowly approaches, eyes calm behind the spectacles. He turns to a few about him, asks a question in one language, another in another tongue; he touches the shoulder of a child in his father's arms. A message of hope and good will to the group, and he is gone.

#### Crowds Gather for Church Pageantry

Still more striking is a beatification. Twice I have watched such a ceremonial, rich with the symbolism and golden pageantry of the church.

On both Sunday afternoons a great crowd pushed through St. Peter's doors to stand in the open area leading to the glowing papal altar. Thousands of lights shone down upon scarlet draperies and the colored likeness of the individual to be beatified.

On such occasions there is a hum, a stir of men and women for whom this hour has a profound significance. They wait and wait, the tension increasing with every passing minute. Here and there bustle officials of a dozen kinds, with ushers in velvet knee breeches, red waistcoats, and black tail coats. Dark-garbed men of high lay orders take



painstakingly repair ancient tapestries, and laymen labor in dozens of shops to preserve crumbling documents, books, and statuary. In and out of the quiet Vatican streets walk cardinals, monsignori, priests, nuns, monks, tradesmen, translators, and visiting laymen from 50 countries.

They are of all shades of skin, of all manners. Italians quickly recognize the various orders, and Americans can tell a few after some study. Students or seminarians are usually easier to identify. Scarlet cassock marks a German, blue sash denotes a Spaniard, green one a Pole, and so on.

With distinguished visitors go members of the Noble Guards, the Pope's bodyguard, a small group drawn from titled families. There are also the Pontifical Gendarmery, who supervise the garden; the Palatine Guards of Honor; and, most celebrated in the popular eye, the Swiss Guards.

More than 450 years ago the Cantons of



places near peasants from the Campagna and monsignori in purple cassocks. Many hold mirrors over their heads to get a better view of the altar.

A signal, a blare of trumpets, a shouted order. Bronze doors open, and the Pope appears on a dais held high. For a moment there is silence at the sight of the tall tiara, the ornamented chair, the white and gold robe extending below the throne. Then starts a chant that continues during his progress down the aisle: "*Viva il Papa, Viva il Papa...*" "*Papa, Papa!*"

The pale hand lifts again and again in blessing as men, women, and children stare in a breathless hush. Many are in tears at the sight of the quiet figure and the face they have known only through pictures. Some have saved money for years to come from far-distant countries.

Now and then the Pope smiles at one or another. An American soldier cries out, and the pontiff bends forward with whispered word... Slowly the dais makes its way to the altar.

From an unseen point begin the soft notes of the choir. Another hush falls as the ceremony begins. The Pope and his assistants move in intense light, and every movement is followed by the throng.

The service is never long, and the slow recessional through the nave, to soaring music, brings more cries of "*Papa... Viva il Papa!*" The throng pushes its way out,

talking of the way the pontiff looked, the sound of his voice. In the piazza thousands stand, their eyes lifted upward, for they know that he will eventually appear in a small window of his third-floor apartment.

A light goes on, the shutters are thrown back, and Pius XII is there to give his blessings. Many kneel, and voices rise that must reach him as a faint echo in the approaching dusk. Then the blinds close. The crowds melt silently away.

#### Halo Glows with Modern Light

After that second beatification, on my final day in Rome, I left St. Peter's for a call at an American airline office. On the way I made out one outdoor shrine after another—scores of them at street corners—elaborate or plain, of wood or alabaster. Each had its handful of flowers, brought by self-appointed guardians. These small points of worship are as much a part of Rome as the fountains, the stairways, the rows of pines, and St. Peter's itself.

In the jungle of traffic, amid the forests of garish new signs, I wondered if those shrines would be lost and forgotten. At the airline office I found my answer.

On the wall of a room fitted in chromium and leather also perched a tiny shrine—a modernized Madonna and Child in plastic, with circle of light in neon. As my friends had said, Rome modifies and it adapts. But it never stops being Rome.





# Hydrofoil Ferry "Flies" the Strait of Messina

BY GILBERT GROSVENOR

Chairman of the Board of Trustees  
of the National Geographic Society



ON a recent trip to Sicily my wife and I enjoyed a "flight" in a new hydrofoil ferry, *Arrow of the Sun*, a winged boat that crosses between island and Italian mainland at nearly 50 miles an hour.

Photographing the sleek vessel awakened memories. Nearly 40 years before, on a windy day on the Bras d'Or Lakes in Nova Scotia, I had photographed the pioneer hydrofoil boat of my father-in-law, Alexander Graham Bell (page 496).\*

Ever since boats have been known, their designers have struggled with the resistance of a hull deeply immersed in water. The higher the hull rides in the water, the less the drag. Therefore, if by some means the boat can be lifted clear of the sea's sucking embrace, the gain in speed is spectacular.

In 1919 Bell's boat, the *HD-4*, raced over Baddeck Bay at more than 70 miles an hour when riding on her Venetian-blind-type hydrofoils. Thirty-eight years later, *HD-4's* run of 70.86 miles per hour still stands, so far as is known, for this type of boat, although a jet-engined hydroplane has all but tripled it.

Naval architect Leopoldo Rodriguez, builder of *Arrow of the Sun*, kindly invited us to make one of the first crossings on the new ferry, which can carry 75 passengers. As we got under way, the boat rode on her hull like any ordinary craft. As our speed increased, she rose higher and higher, and in less than half a minute we were "foilborne."

We headed across the rough water of the strait. Riding high on our hydrofoils, we sliced through the chop with no pitching or rolling. We felt only the slight recurrent bumps of the wave tops.

That is the second big advantage of hydrofoil vessels: they travel so smoothly that no one becomes seasick, and they can navigate at high speed in seas that keep ordinary craft in harbor.

We made the run from Villa San Giovanni to Messina harbor, 4.4 miles, in 5.5 minutes. In regular service *Arrow* crosses between Reggio Calabria and Messina, 8.1 miles, in 10.5 minutes. Ordinary ferries take 50 minutes for the same trip.

## Hydrofoils Act Like Airplane Wings

Hydrofoil designers use aeronautical terms and speak of "flying" their boats. This is legitimate language: a hydrofoil flies through the water as an airfoil flies through air, producing lift by deflecting the flow of water.

There is one big difference between an airplane and a hydrofoil boat. The hydrofoils fly through a medium 800 times as dense as air. This means that comparable amounts of lift can be obtained with very much smaller foils than those used in aircraft.

Hydrofoil craft, of course, have some disadvantages. In a following sea, the speed of the wave may exceed that of the foils, allowing the foils to stall and the boat to "crash," or drop down on the water. To avoid this, the boats may tack like sailing vessels.

They are in addition somewhat vulnerable to floating debris, which might smash the foils projecting below the surface. Maneuvering alongside piers or other vessels grows more complicated because of the jutting foils.

But the advantages of the design are so attractive that hydrofoils have captured men's

Page 492

### ← *Arrow of the Sun* Starts Like a Boat; Speeding Up, She Flies Clear of the Sea

En route to Messina, in Sicily, the 75-passenger *Arrow* leaves Villa San Giovanni, on the toe of the Italian boot. Getting under way (above), the ferry floats on her hull; within 30 seconds she rises and flies on her foils at 43 knots (below).

Two V-shaped foils, shaped in cross section like an airplane wing, create lift by deflecting water flowing around their surfaces.

© National Geographic Society  
Illustrations by Lutz Marlow, National Geographic Staff

\* See "Alexander Graham Bell Museum: Tribute to Genius," by The Honourable Jean Lesage, NATIONAL GEOGRAPHIC MAGAZINE, August, 1956.





## Foils Fly in Water; the Hull Rides in Air

Hydrofoil boats can race over rough seas that immobilize ordinary craft. Their water-borne foils act so much like aircraft wings that designers say of a successful model, "It flew."

These boats, like airplanes, lose flying speed and stall when slowed down. Normally they descend gently, but occasionally hit the water with a bump.

Because of the steep V form, part of the *Arrow's* hydrofoils always remains submerged to give lift.

Unlike Dr. Alexander Graham Bell's *HD-4* (page 496), the vessel is driven by an underwater propeller. This view exposes the shaft, which slopes down from midships, keeping the propeller at proper depth. Here the *Arrow* returns to the mainland.

↓ Using a boat hook, a crewman tends the unshielded bow foils from a Messina pier. These foils may be tilted up or down to change fore-and-aft trim.

© National Geographic Society

Gilbert Grosvenor (left, above)  
and Luis March

495

## ← Steel Fender Protects Vulnerable Stern Foils

A hydrofoil boat's jutting underwater planes require delicate handling at dockside. Some experimental naval landing craft employ retractable hydrofoils.

Inclined struts connect foils to hull.

Designed by a German, the 27-ton ferry was built of aluminum alloy in Messina. In trials she made the Naples-Palermo run in 4½ hours, as against the 12 hours required by the overnight ship.

↓ Figures on bow foil indicate the keel's height above water (in centimeters). When cruising, the hull rides about two feet clear.



minds for more than 50 years. In Italy, Enrico Forlanini experimented with hydrofoil boats shortly after the turn of the century, and in 1905 he succeeded in lifting one clear of the water at 44 miles an hour.

World War II's greatest hydrofoil activity took place in Germany. The Germans constructed several types for fast patrol work and other purposes.

Most of the German boats were built on the patents of Hanns von Schertel, a designer who had studied under Forlanini, and who, after the war, formed a new company in Switzerland. It is under these patents that the Messina boats are built in Sicily by the Rodriguez shipyards.

#### Navy Developing Hydrofoil Craft

The United States Navy has been actively developing hydrofoil vessels since 1947. The development program is carried on jointly by the Office of Naval Research and the Bureau of Ships. Rear Adm. Armand Morgan, Assistant Chief for Ship Design and Research, directs the work for the Bureau of Ships.

Congress has already appropriated money for a prototype landing craft.

"If a man is shooting at you, you like to

go in fast," says the admiral. "But to go into a beach, you must make the foils retractable. And that isn't easy."

On the civilian front, *Arrow of the Sun*, as it furrows the Strait of Messina, joins an increasing fleet of hydrofoil boats in public and police service. Another ferry was launched in December at the Rodriguez yards.

One United States manufacturer builds hydrofoil runabouts on order. A large aircraft manufacturer is about to enter the field. Hobbyists can even buy a do-it-yourself hydrofoil kit for their outboard motorboats.

A question that naturally occurs to many people who see a hydrofoil boat for the first time is: How big can such boats be built? At present, 100 tons would seem to be the practical limit. On the other hand, some reputable scientists do not hesitate to predict ocean-crossing hydrofoil ships.

The distinguished scientist Dr. Vannevar Bush has made this prediction:

"In a few years there will be hydrofoil craft of many types and designs flying about the coasts. When that occurs, progress will become automatic and irresistible, and one will wonder how there ever could have been so many skeptics."

#### Alexander Graham Bell in 1919 Watches His Hydrofoil Boat Stilt-walk on Water

Edbert Grossman



#### ← *HD-4* Flashes By Like a Torpedo

Twin Liberty aircraft engines lifted the 10,000-pound hull even at low speeds and drove it to a record 70.85 miles an hour. The author shot these dramatic views on the Bras d'Or Lakes near Baddeck, Nova Scotia.

A Noted Zoo Director, Now Retired, Recalls the Highlights of 30 Years' Collecting, Trading, and Nursemaiding Birds and Beasts

BY WILLIAM M. MANN

I BRACED myself for the inevitable question, and before the soup was cool, it came. Brightly my dinner partner turned to me and said:

"Dr. Mann, tell us: In all your years of dealing with wild animals, what has been your most exciting moment? Was it in Africa? Up the Amazon? In the jungles of Sumatra?"

I sighed, reluctant to add her to the ranks of the disillusioned.

"As a matter of fact, my most exciting moment took place at my desk in the zoo. The phone rang, and at the other end was the office of Mr. Harold Ickes, head of the Public Works Administration.

"They told me that we had been allotted \$870,000—the biggest appropriation for new construction we'd ever had. It meant we could finish the birdhouse, build two new animal houses, and put up some needed machine shops. I nearly dropped the receiver."

"Oh."

The lady was disappointed. They all are, when I tell that story. But any zoo director will understand.

## Beasts from Aardvarks to Zebras

Many American kids grow up with an itch to be a policeman. So did I, but with a difference. After haunting Chicago's Lincoln Park zoo in the summer of 1895, when I was nine years old, I knew I wanted to be a policeman—in a zoo. I saw myself in daydreams sporting a big mustache, swinging a club, spending all my time with the animals, and being kind to visiting children.

Well, I have eventually grown the mustache, lost interest in the club, spent nearly all my time with animals, and proved reasonably nice to visiting children—as long as they don't throw rocks at the bears.

I've never donned that policeman's blue suit, but I have served as director of the National Zoological Park in Washington, D. C., for nearly a third of a century, collecting, trading, nursemaiding, and boarding beasts and birds, from aardvarks to zebras, from vest-pocket-sized shrews to skyscraper giraffes. And I've enjoyed just about every minute of it.

Our zoological park is called "National," and it is. A division of the Smithsonian Institution, it receives its financial support from the District of Columbia government and Congress. If I should ever be tempted to think of the zoo as a mere appendage of the District of Columbia, I need only walk past our parking facilities. There on any good day I can spot license plates from virtually every State in the Union.

## Zoo Displays Real Prizes

In our 175-acre compound on the banks of Rock Creek we have not only a comprehensive cross section of the animal kingdom but also several real prizes.

"Thou shalt not covet thy neighbour's... ox, nor his ass..." Right! But what rival curator could resist coveting our fossa (a civet from Madagascar), a rarity in any zoo, or our hybrid bears, Frances and Elizabeth—the "impossible" grandchildren of an Alaskan big brown bear and a polar bear?

Who wouldn't want our tuatara, a New Zealand reptile related to the ancient dinosaurs? Frankly, I should hesitate to trust one of our out-of-town competitors alone with, for instance, our "white," or square-lipped, African rhinos, the only specimens of their kind on exhibit in the New World.

---

## The Author

Director of the National Zoological Park in Washington, D. C., from 1925 to 1956, Dr. Mann enjoys an international reputation as an authority on zoo animals and ants. More than 100 species of insects bear the honorary ascription *manni*, and the personal collection of 117,000 ants he gave the Smithsonian Institution in 1955 ranks among the world's finest.

Never too busy to answer questions from the National Geographic, Dr. Mann for 30 years has helped to assure the accuracy of natural history information in The Magazine. He led the highly successful National Geographic Society-Smithsonian Institution expedition described in "Around the World for Animals" in the June, 1938, issue, and his other notable contributions have ranged from ants to apes: "Stalking Ants, Savage and Civilized," August, 1934; "Monkey Folk," May, 1938; and "Man's Closest Counterparts," August, 1940.

His works include two popular books, *Ant Hill Odyssey* and *Wild Animals In and Out of the Zoo*.



The collection at our zoo didn't crop up overnight. Far from it. And its beginnings were as modest as anything could be.

The Smithsonian's United States National Museum had been maintaining an informal and ill-housed menagerie, partly for the benefit of its biologists and taxidermists, partly as a transient boardinghouse for animals given the Government by grateful citizens. When our first keeper and my mentor, Mr. W. H. Blackburne, borrowed a wagon from the Humane Society in 1890 and began to ferry the museum's bison, elk, mountain sheep, eagles, and monkeys out to the newly authorized National Zoological Park, a sigh of relief went up from Smithsonian officials.

But a zoo really isn't a zoo without elephants. Ours came that same year as a gift from the Adam Forepaugh Shows—two hulking African pachyderms named Gold Dust and Dunk.

Followed by every small boy at large in Washington, this pair trudged through the city from the circus grounds, with Mr. Blackburne dashing ahead to caution carriage drivers to hold a tight rein on their horses. One elderly expressman with a somnolent nag shrugged off the warning; his horse, he said, was too old to bolt.

He was wrong. However, this proved the only unnerving incident en route; the elephants were soon chained to a tree, and the zoo was in business!

A blacksmith's wife, who had raised a lion cub in the same basket with the family tabby cat until the neighbors complained, gave the zoo its first lion. A sulphur-crested cockatoo was presented by a couple in Maryland. A

dealer offered a kangaroo for \$75 in exchange for guinea pigs at 15 cents a head; in three years the zoo raised enough guinea pigs to retire the mortgage on the kangaroo.

One winter the Forepaugh Shows left all their animals at our zoo; in return we were to get any offspring that arrived before the circus hit the road again in the spring. Our net gain: two kangaroos and a lion cub.

#### Zoo Waited 36 Years for a Giraffe

So it went. By hook or crook and by frequent strokes of luck, we added gradually to our collection. But it was 36 years before we acquired a giraffe—in fact, two of them, Hi-Boy and Dot, part of the Noah's Ark-load we brought back from our Smithsonian-Chrysler Expedition of 1926. As they were at last being unloaded at the zoo, I retired behind the bird cages and shut my eyes.

My wife Lucy was astounded. "Aren't you even interested enough to watch?" she asked.

"I can't," I replied. "I've looked after those animals for 40 days at sea, and if they broke their legs now, I couldn't bear it!"

Well, they didn't. But they nearly broke Bill Blackburne. When he stepped into their cage to pet them, Hi-Boy gave him a vicious kick in the ribs.

"Did it hurt?" I asked him.

Bill shook his head. "No," he said, "it is a pleasure to be kicked by a giraffe in my own zoo."

I knew how he felt.

Despite my early interest in animals, I was 18 before I got a temporary job in a zoo and 39 before I returned to it. My first venture into the world was at 12, when I ran away from home in Montana to become a cabin boy, work my passage to South Africa, and help the Boers win their freedom. I got as far as a ranch 40 miles away.

At 14 I wrote Admiral Peary that I would be glad to join his next expedition to the North Pole, but my mother had other plans. She sent me to military school, not so much to become a general as to learn to polish my shoes.

One vacation I tried to join the Ringling Brothers circus at Baraboo, Wisconsin, as a keeper. Charles Ringling replied: "Advise a boy of your age to choose some other line of occupation as more desirable in every respect."

I went back to military school. In the fall my fondest wish was suddenly realized: the

Page 498

#### ← Stop Where You Are! 450 Pounds of Striped Lightning Serves Warning

Largest of cats next to the lion, the male tiger may measure more than 10 feet from nose to tail tip and weigh as much as 650 pounds.

In forests from Siberia to Bali and westward into Iran, *Felis tigris* rules as king. His rufous-yellow black-striped body strikes terror in deer, young water buffalo, and elephant calf. He usually leaps and hugs his victim, then bites the throat.

"The tiger is not as demonstrative as the lion," says the author. "He will not perform boyish tricks or beg for handouts. He is dignity itself, and he looks right through you."

These young males eat 10 to 16 pounds of horse meat apiece a day. Each weighs about 225 pounds.

© National Geographic Society  
Illustrations by Robert F. Steen and Donald McFie,  
National Geographic Staff





**Courting Peacock Spreads His Train: a Hundred Eyes Sparkle in the Sunlight**

*Pavo cristatus*, a native of India and Ceylon, was imported into ancient Palestine, Greece, and Italy. Romans knew it as the bird of Juno; epicures dined on peafowl tongues. More than 200 feathers make up the fan.



**To Hold His Balance Beneath Swaying Plumage, the Vain Male Struts on Stiff Legs**

Peacocks wander freely through the zoo and sometimes stroll out into the streets. Belligerent males in search of a mate often fight their reflections in shiny cars. Not easily bluffed, the bird faces rivals boldly.

barracks burned down. Fast as the mails could travel, I landed a job at the National Zoological Park as a laborer.

I reported to Mr. Blackburne at the lion house. He sent me to clean the spotted hyena's cage. It was rather a large hyena, and I approached its den with mixed feelings. But Jake, one of the assistants, told me that if the hyena frightened me, I should simply bang on the bars with my brush.

This technique proved effective enough in keeping the hyena at bay. Suddenly, however, a rhesus monkey in the next cage reached through the bars, knocked my glasses on the floor, and, when I stooped over to pick them up, grabbed me by the hair.

Mr. Blackburne, observing all this, muttered something to himself about sending a boy to do a man's job.

At any rate, I couldn't seem to land a permanent post as an animal keeper at this zoo or any other. In fact, I was actively discouraged. Wrote one director, Hornaday of the Bronx zoo: "A keeper is too busy fighting dirt, disease, and disorder among his charges ever to learn anything about them."

Instead, I went into entomology and for the next 15 years knocked about the globe in pursuit of ants and beetles. I enjoyed myself enormously and had a measure of success. But I guess I never looked much like a bug hunter. At any rate, when I was presented to the President of Haiti on one occasion, he seemed quite baffled. "Entomologist?" he repeated dubiously. "But where are the bald head and the beard?"

#### Collecting Crows the Easy Way

If I imagined, as I took over my functions as director of the zoo in 1925, that I had eased into a sedentary occupation, I was soon to be disillusioned. In any colony of living things there is bound to be a constant turnover; losses have to be made good by purchase, by Machiavellian trades with other zoos, and by actual capture in the field.

In my years of poking into odd corners of the world after small and large game, I found it sometimes ridiculously simple to acquire specimens, more often nightmarishly difficult, but always fascinating. Taking my tea on a veranda in India, I collected native crows the easy way. The birds were darting down from the trees above us and stealing raisins from our buns. Turning to a couple of Hindu youngsters who were lounging near by, I

asked them if they were good bird catchers.

They grinned confidently and disappeared. In a few minutes they returned with a brace of our raisin thieves—who are still serving their sentences, raucously but happily, behind the bars of our zoo.

Usually, it's a bit trickier. In Africa, one summer, we were hunting wild buffalo along the swampy shores of a lake when we glimpsed a herd of about 200 drawn up before the fringe of some woods. We wanted a live calf, and the best way seemed to be to convert a mother animal into a trophy. So my companion raised his single-barreled howitzer and banged away.

In the next instant the herd swung about, gave us its undivided attention, and I heard George shout, rather unnecessarily, "Look out, they're charging!"

We ran. It seemed the thing to do, even though I could see no shelter to which to run.

#### Mud Foils Charging Buffaloes

The angel who keeps an eye on itinerant zoo directors, however, was on the job. Thundering across the veldt, the buffaloes closed to within yards of our retreating backs and then, suddenly encountering the lake's oozy shore, split into two groups and surged harmlessly past us on either side.

I have always had a distaste for mixing adventures with animal collecting. In my experience, people who have adventures generally get killed, something which is not efficient at all. Once, in Tanganyika, we had tracked and finally roped a young gnu in the cane near a lake. The gnu looked pretty tuckered out, and we all stepped back and relaxed. About 10 seconds later the beast was coming at me like a rocket, its four-inch daggerlike horns aimed at approximately the third notch on my belt.

I did not hesitate a moment. Firmly and resolutely, I sat down in a foot and a half of muddy marsh water, and the gnu whizzed overhead in a blur. The boys eventually caught and subdued the animal, hoisted it on their shoulders, and triumphantly carried it off to camp.

It's one thing to trap a wild animal, and quite another to get it to a ship for the long voyage home. When the Forest Department in Assam managed to bag for us a very rare great Indian one-horned rhinoceros, their laborers had to hack a new eight-mile road through the dense jungle in order to trans-

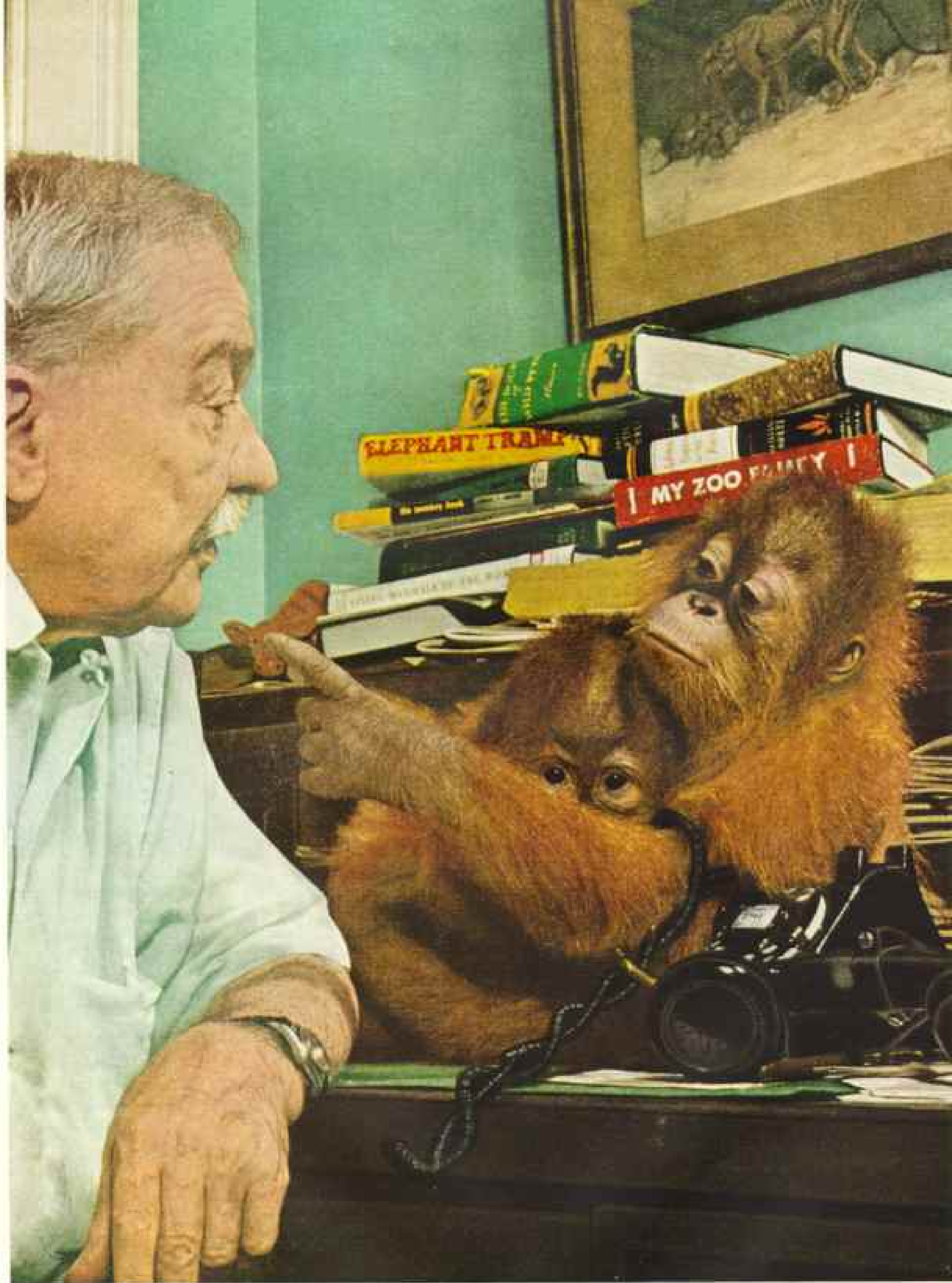

**"It's for You, Doc . . . and Don't Forget to Order Some Bananas"**

Sumatran orangutans, posing here as the author's telephone monitors, are born clowns. They can be taught to smoke cigarettes, drive nails with a hammer, and ride bicycles. Frisky and goblinlike in youth, *Pongo pygmaeus* grows sluggish and sober with age. At least one circus specimen has been billed as "The Wild Man of Borneo."



### "Not a Penny More!" The Author Bargains with Young Indonesians for a Pet Cockatoo

Dr. Mann, on a National Geographic-Smithsonian expedition in 1937, circled the world in search of zoo animals. He bought this rose-crested cockatoo on the island of Ceram. The bird, which "spoke" Malay, soon added English. For years his shrill command, "Open the door, Richard," has delighted zoo visitors.

port it, caged, to the nearest railroad line.\*

And when we lured a pygmy hippo of Liberia into a pitfall in 1940, our bearers had to lug the 400-pound creature through swamp and forest for 40 miles to our base camp—a journey, I feel confident, neither they nor the hippo would ever care to repeat.

Even after you get an animal aboard ship, you are likely to discover that your problems have just begun. Once I was bringing a tapir down Bolivia's Beni River in a motor launch with a whistle-happy captain. Whenever he rounded a bend, neared a landing, or felt an urge to express himself, he blew the whistle—and the tapir jumped overboard.

We finally worked out an agreement with the captain: If he sensed the impulse to toot coming over him, he would notify us in ad-

vance, and we would lock the tapir up until the crisis had passed.

On another trip I was bringing back a dragon that hailed from the island of Komodo in Indonesia. Oh, well, a dragon lizard, if you insist—a fine specimen more than seven feet long. At any rate, three days out, a seaman rushed up to me and shrieked, "Lizard loose, Master! Lizard loose!"

I was somewhat concerned. I couldn't tackle this carnivorous character by myself, and the crew, as one man, declined to assist. I didn't believe the lizard would devour any of the passengers, but I was afraid he would gobble his way through the precious consign-

\* See "Stalking the Great Indian Rhino," by Lee Merriam Talbot, NATIONAL GEOGRAPHIC MAGAZINE, March, 1957.

ment of birds and small mammals we had in the hold. The thought of his dining upon my birds of paradise at \$100 a bite was more than I could stomach.

So, even if I couldn't play St. George to this dragon, I did the next best thing; with the aid of my one helper, I managed to move all the other animals and birds topside. Only after we reached Sumatra and could summon reinforcements did we confront the rampaging monster and subdue him.

It's a bit hard to regulate the weather for animals on a homeward cruise. Coming through the Red Sea in 1937 on our wonderfully profitable expedition for the National Geographic Society and the Smithsonian Institution, the thermometer was pushing 117° F. Somehow I managed to survive, but I had to douse my monkeys and bears with water

to bring them out of a complete collapse.

When we headed into the chilly North Atlantic, we ran into the opposite problem: our giraffes shivered and shook on deck. We strung up a hatch of 500-watt bulbs and beamed their warmth into the cages. It worked, but I often wondered whether the giraffes weren't a little bit astounded to discover that for them the sun never went down.

Sometimes our efforts to shelter our animal passengers led to unexpected results. Bringing a cargo of monkeys, wildcats, cranelike trumpeters, and other creatures from South America one year, I found our captain grudgingly sympathetic with their exposed plight. He ordered a coal bunker cleared out, and we moved the menagerie below for the last days of the voyage.

Unfortunately, by the time we docked, coal

#### An Artist Catches Bobette, House Guest of the Manns, at Bottle Time

Neglected by her mother, the tiger cub lived three months in the zoo chief's home. Atanas Tasev portrays her.

The Washington Star



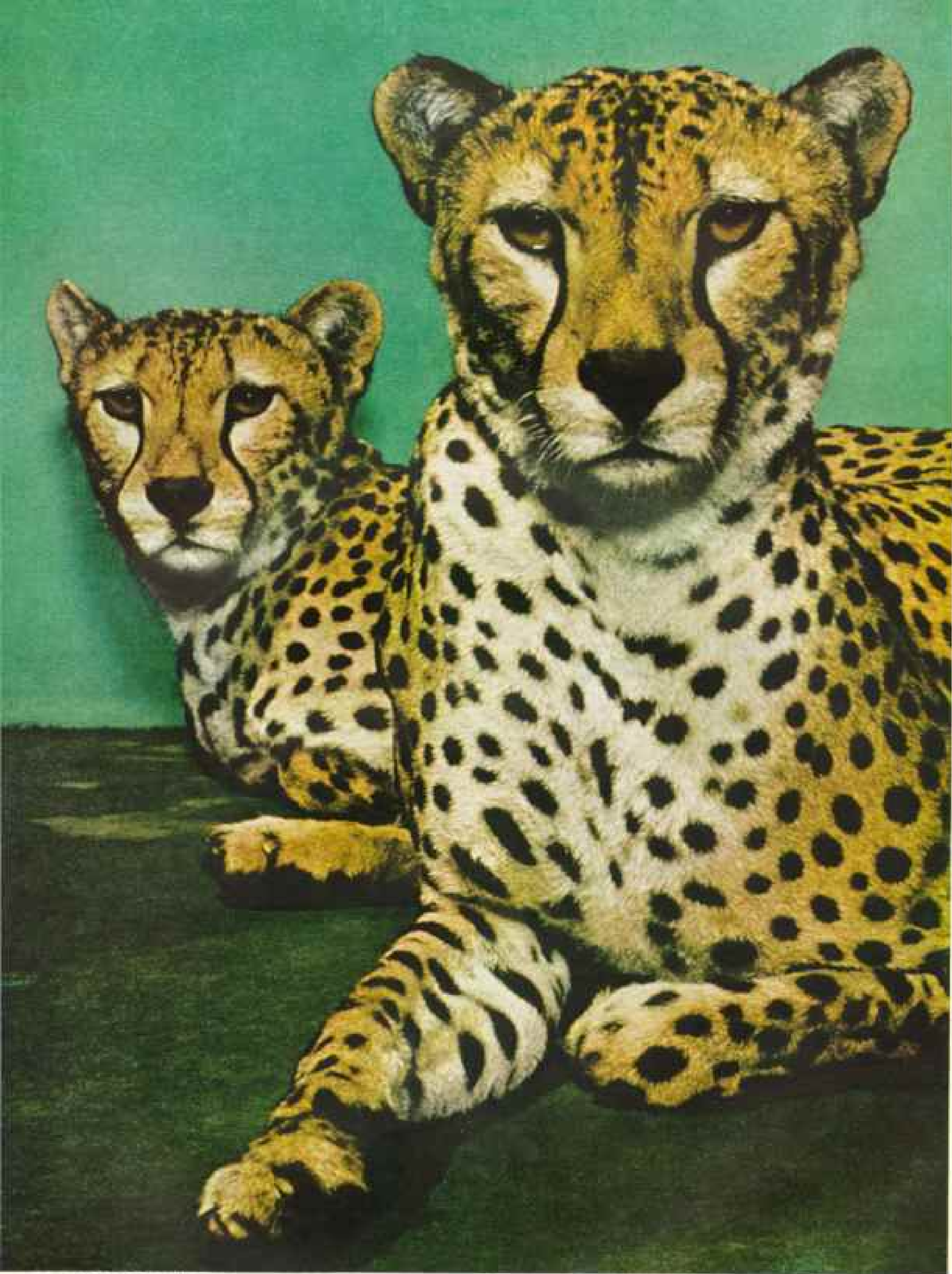

### Cheetahs, Swiftest Hunters on Four Legs, Show Cats' Faces on Doglike Bodies

Easily tamed and trained, cheetahs respond to their names and follow their masters like dogs. Indian noblemen employ them in hunts. Though a true cat, *Acinonyx jubatus* is shaped like a Great Dane and his blunt claws are not fully retractile. His speed has been clocked at an incredible 70 miles an hour.

dust had so effectively disguised our animal friends that it was days before we could identify some of them with confidence.

One zoo man I know had to take several snakes to Washington from New York with him in a Pullman berth, to make sure they were warm enough. On my way back from the Amazon I used to keep a gentle young marmoset in a woolen sock; it would curl up contentedly in the toe.

Even after one has successfully brought an assortment of animals through a hazardous ocean trip and unloaded them at the zoo, a slip can bring disaster. In 1926 we caught four wart hogs in Tanganyika. On the voyage back one of them dived 30 feet into the stokehold and drove the Moslem hands scrambling up the bulkheads, where they hung like grapes on ropes. The animal eventually succumbed to a lasso. It was only when we let the quartet loose in their pen at Washington, however, that they really hurt themselves. One May morning the doors to the outer paddock were flung open, the hogs tore out for home and freedom, ignored the iron fence, and crashed into it headfirst.

Score: All four knocked out, one dead.

#### Most Animals Live Longer in Zoos

The hogs wanted to get out—no doubt about that. But don't assume that all our animals are pining for their freedom and are miserable at being caged. It doesn't really follow that, because you would resent this confinement, the tiger, bear, or monkey does.

As a matter of fact, my years of observing animals from the other side of the bars have convinced me that most of my guests live longer, healthier, and happier lives in the zoo than in the wild.

And why shouldn't they? A wild animal is wild because it lives a life of almost constant fear—fear of enemies, fear of starvation, fear of being unable to defend its chosen living space. When we give it a home of its own, the assurance of food, and protection from any marauders, its most basic needs have been met.

No longer does it suffer from wounds and feel the misery of ticks, fleas, and other parasites. No longer must it know the anxieties of old age, when failing eyesight and slower reactions make each day's foraging more difficult and itself a more likely victim of some stronger animal's teeth and claws.

All right, I can hear you murmur that

fear is the price of freedom. But I must politely insist that an animal knows no abstract ideas of freedom; it knows only the urge to survive. Satisfying that urge, we satisfy the animal.

You reply, of course: If the animal is so satisfied, why does it pace restlessly, hopelessly, up and down before the bars of the cage?

The answer is simple: It paces to get exercise, to work off excess energy. It likes the rhythm of its dance—in fact, if certain animals are interrupted momentarily or miss a step, they will stop and begin all over again. The cage hasn't much to do with it. You can sometimes spot a bear in the wilds indulging in the same back-and-forth pacing on a ledge near its den, or a gorilla performing the same shuffle in the jungle.

Space—an animal wants all it needs, but too much is a threat. If we give it too big a cage or yard, it will huddle in one sector of it and shun the rest.

Let's take the wolf. One day four of our gray wolf pups, with their parents, had a fine time breaking through the wire mesh of their pens. And where did they go on their great bid for freedom? Why, to the rear door of the lion house. The keeper found them there, hours later, waiting patiently for their rations. He picked up a bucket, and they followed him back to their cage, trotting happily along like so many collies.

#### Baboon Enjoyed Stealing Umbrellas

Most animals, it seems to me, take their incarceration like gentlemen. A few, however, do become rather bad actors.

We had a long-armed chacma baboon from Southern Rhodesia who loved to loll against the bars of his cage. Seemingly comatose, he would entice visitors to stir him up with an umbrella, and then snatch it. His lifetime record: 68 umbrellas and canes, a gold watch, a feather boa, a policeman's helmet, and a Congressman's hat and gloves.

Barbary apes can play rough, too. George, a bad-tempered type, used to throw rocks at small boys. If he had aimed only at the boy who had originally thrown the rock at him, I wouldn't have minded. But one boy was just like another to George, and we had to screen his cage with mesh—which didn't stop him from splashing visitors with water from his drinking basin.

A pair of elephant seals took a similar de-



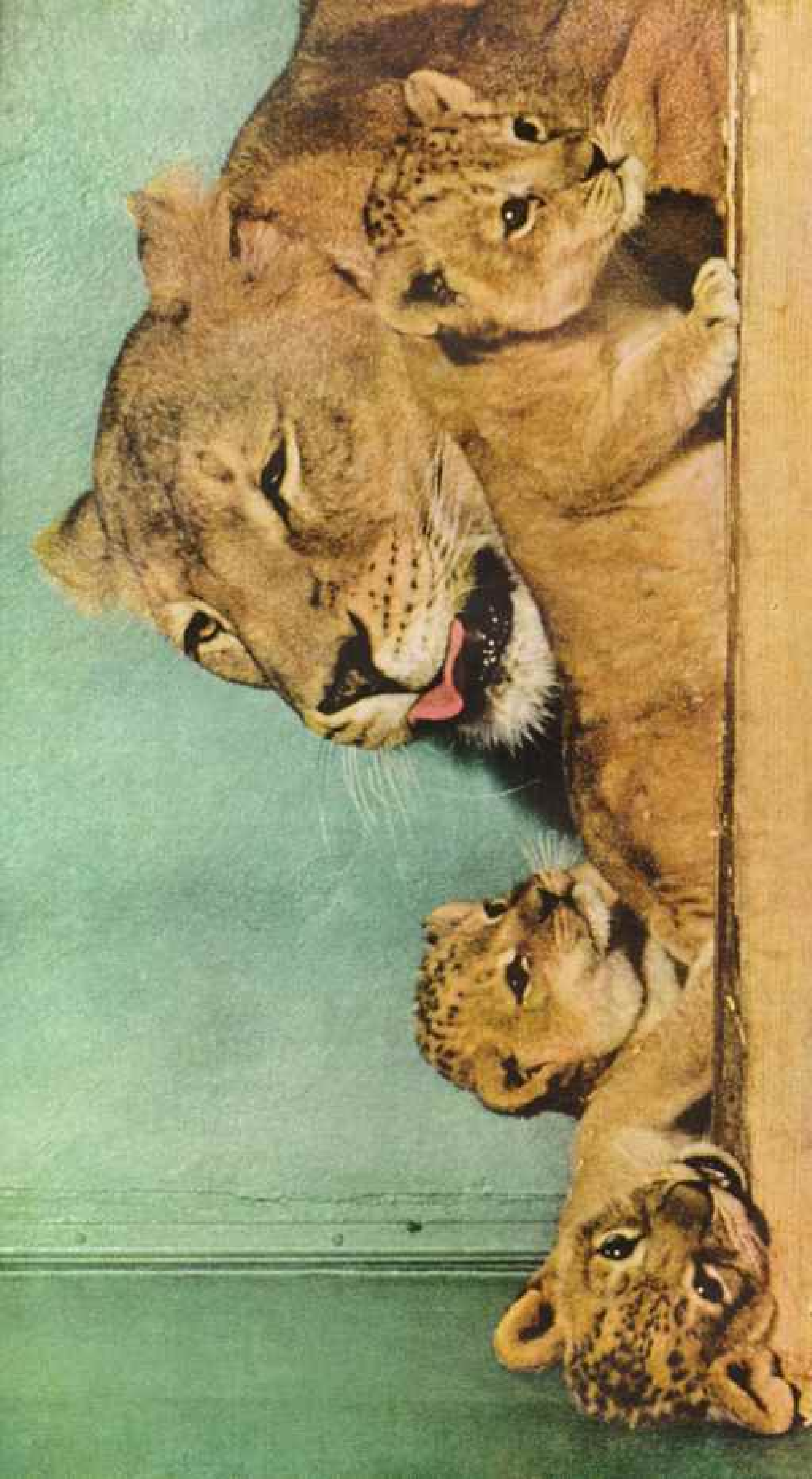

↑ **Cuddly as Kittens, Lion Cubs Are All Fuzz and Frolic**

Captive lions reproduce so readily that they have become a drug on the market in the United States. These cubs, only a few weeks old, retain spots on heads; the marks will vanish later. An exemplary mother, *Felis leo* enforces discipline with gentle but firm cuffs.

↓ **Bongo's Cavernous Jaws Gape for a Three-bushel Dinner**

A mere 895 pounds when he arrived from Africa in 1914, this hippopotamus now scales 6,000 pounds. Bongo's mate lines up beside him at feeding time. Each consumes about 50 pounds of food a day. Curved tusks in the lower jaw of captive hippos require periodic filing lest they pierce the upper lip.



light in giving bystanders impromptu shower baths with mouthfuls of water before the public caught on to their accomplishment.

Dangerous less to visitors than to their own cell mates are the male elks and Kashmir deer in the rutting season. A bull elk is quite a mild fellow until autumn rolls around; then watch out! Before we learned better, our bulls went berserk and killed several does and calves. Now we dehorn the bad actors well ahead of time.

It is a pity to lop off antlers as magnificent as those the Kashmir grows. But with one male we had no choice. We were afraid he would break out. As soon as his horns were gone, however, he lost all his fight.

There are few sounds charged with such unadulterated hostility as the snort of a charging Kashmir. During mating season his roar reminds one of a leopard's snarl and is about as soothing.

For every bad actor among our animals we have, however, at least one among our visitors. Bambi, a little Virginia deer that had been raised as a pet, was murdered one night by men who scaled the park fence, slaughtered trusting Bambi, and dragged her over the fence to a waiting automobile. The killers had venison—and children who come to the zoo long mourned a gentle friend.

#### Balloon Panics Giraffe

Then there was the idiot who picked leaves in the woods and, despite a warning sign, fed them to our prized Diana monkey. Those particular leaves are poisonous to monkeys, and the Diana died in agony.

I'm thinking, too, of those who, when the guard was looking the other way, let a balloon drift into the giraffe cage. A giraffe chewed on the string, the balloon batted him around the head, and he ran frantically about his enclosure, nearly breaking his legs and neck. Every zoo director has his own list of visitors who wouldn't be missed.

I suppose we feel the more annoyed at these blunderers because we have come to know our animals as quite special and individual beings. The tigers, of course, are superb snobs, incapable either of begging or of philosophic acceptance of their fate; they will look right through any fool who thinks a kind word or gesture will buy their friendship (page 498).

But the monkeys, apes, and bears—well, they are certainly willing to put on a show.

When N'Gi the gorilla was alive, he would delight in amusing the children, balancing dumbbells on his shoulder or solemnly donning his drinking pan as a helmet. One of our gigantic Alaskan bears begs in the most obvious way, sitting down and grasping its hind paws with its front ones in such a manner as to create the largest possible lap into which peanuts can be tossed.

Another bear, upon command, pretends to bite one of his paws. We have one that makes motions as if powdering his nose when somebody gives him the proper order. Nobody taught these bears their tricks, so far as we know. They simply learned all by themselves the best ways to get peanuts.

#### Mynah Bird Turns Lobbyist

We have had an otter that loved to swim balancing a rock on its nose, a cockatoo that persisted in screeching, "Open the door, Richard!" (page 504), and a mynah that was suspiciously talented.

I say "suspiciously," because some folks believe the bird was coached in its memorable performance before the director of the Federal Bureau of the Budget. Gen. H. M. Lord had scarcely approached the mynah's cage when it sang out, "How about the appropriation?"

Understandably, the general was a bit irritated. "Who educated that bird?" he asked.

His only reply came from the mynah. "How about the appropriation?"

As the newspaper reporters reached for their pencils, the general snapped, "That is impertinent!"

To which the mynah replied, in impeccable slang, "So's your old man!"

Well, we did get the appropriation, and I always afterward considered that the mynah occupied its perch rent-free.

We have other boarders at the zoo that are somewhat more difficult. We have never, for example, had much luck in keeping moose.

Page 511

#### Toucan, the Cyrano of Birdland, Sports a Rainbow on His Beak

More than one zookeeper has been falsely accused of daubing water colors on this tropical flyer's outside bill. Though it appears massive, the beak weighs little more than an ounce.

Some 87 kinds of toucans inhabit forests from southern Mexico to northern Argentina. Scientists call this species *Ramphastos toco*.

© National Geographic Society

Robert F. Sisson and Donald McEwen, National Geographic Staff



Of the 10 that have lived at the zoo, none has survived more than three years, even though they were given plenty of birch browse on which to munch. It's virtually impossible to reproduce for them in Washington the aquatic fodder of their northern home and the year-round coolness.

Others of our 3,000 guests, too, provide dietary problems. Tropical spoonbills and scarlet ibises, brilliant in their plumage, tend to fade if we don't offer them enough crab scraps. Lesser pandas at first ate only Pabulum and bamboo shoots but later learned to handle a more varied diet.

We can't board a koala bear, because we can't guarantee a supply of the only food this delicate little animal can tolerate. The cuddly creatures eat the leaves of certain kinds of eucalyptus trees, and even these leaves must be mature ones, not foliage produced by young eucalypts or trees recently damaged.

Few animals are more charming than koalas, natives of Australia. We'd dearly love to have a few in the zoo, and my valued assistant, Mr. Ernest P. Walker, even went so far as to investigate the possibility of growing the proper eucalypts in Rock Creek Park. The botanists could give him no encouragement, so we dropped the idea.

And we have all sorts of trouble with our pelicans—not because they are choosy about what they eat but, on the contrary, because they are willing to gulp down anything. From

#### Rare Cowbird Was Believed Extinct

Brought to the zoo last year, this Colombian red-eyed cowbird was the first of its species observed since 1866. Scientists presume that the bird, like its relatives, lays eggs in others' nests and lets the duped foster parents hatch and raise its young.

Viktor Westral, National Geographic Staff



one of our pelicans, who seemed a bit off his feed, we extracted an 18-inch piece of wooden window-screen moulding, complete with protruding tack heads. It had stuck halfway down his throat.

When it comes to sick call, we run into a curious array of ailments. The hippo needs a trip to the dentist; its curved tusks, which in the wild it will wear down in the course of uprooting its leafy food, have to be filed to keep them from piercing the upper lip (page 509). Our elephant Jumbina required a pedicure; in captivity an elephant's soles and nails sometimes grow too thick, crack, and pick up sharp objects from the ground.

Incidentally, have you ever tried to cure an elephant of a stomach ache? One method, favored in circuses, is to slap on a thick poultice of mustard and then administer a liberal chaser of gin-and-ginger. Unfortunately, some elephants get such a taste for this remedy that they will roll over and pretend to be at death's door just to get another shot of "medicine."

#### First Aid for an Ailing Tiger

Once we had to administer some castor oil to a sick tiger. This job can be rather awkward. My friend Blackburne solved the problem finally by climbing on top of the cage, tickling the tiger's nose with a carriage whip, and provoking him to rear up and bite. As his jaws flashed open, the castor oil poured down. What missed his mouth dripped onto his head and paws, which he proceeded industriously to lick clean.

In a few hours he was feeling quite himself again.

A zoo is not just a boardinghouse or a side show, of course. It is also, in an odd way, a laboratory. In our zoo, for example, we confounded all the genetic authorities by breeding our Alaskan big brown bear to our polar bear.

The whole thing was an accident. Like so many zoos, ours is crowded. These two bears seemed compatible and were given the same cage. To our complete surprise they presented us with offspring.

As a matter of fact, there were 23 cubs over a stretch of 20 years. Four lived to adulthood. We bred together these supposedly sterile hybrids and—once more to our surprise—there came second generation cubs. Only two of 14 survive (page 515).

(Continued on page 521)



↑ **Tiny Arrow-poison Frog Secretes  
Venom in Its Back**

South American Indians dip blowgun darts into a liquid extracted from the amphibian. This specimen came from Colombia. Its scientific name is *Dendrobates tytophagus*; Washington Zoo officials call it gold-and-green arrow-poison frog.

↓ **Chameleon, a Quick-change Artist,  
Swaps Colors to Suit Its Mood**

Changes in light, temperature, and emotions affect the coloring of *Chamaeleo jacksoni*. Lizard's insect-snagging tongue can flick out eight inches. One eye can look up while the other pivots down. Oversize eyelid has a peephole, here aimed backward.

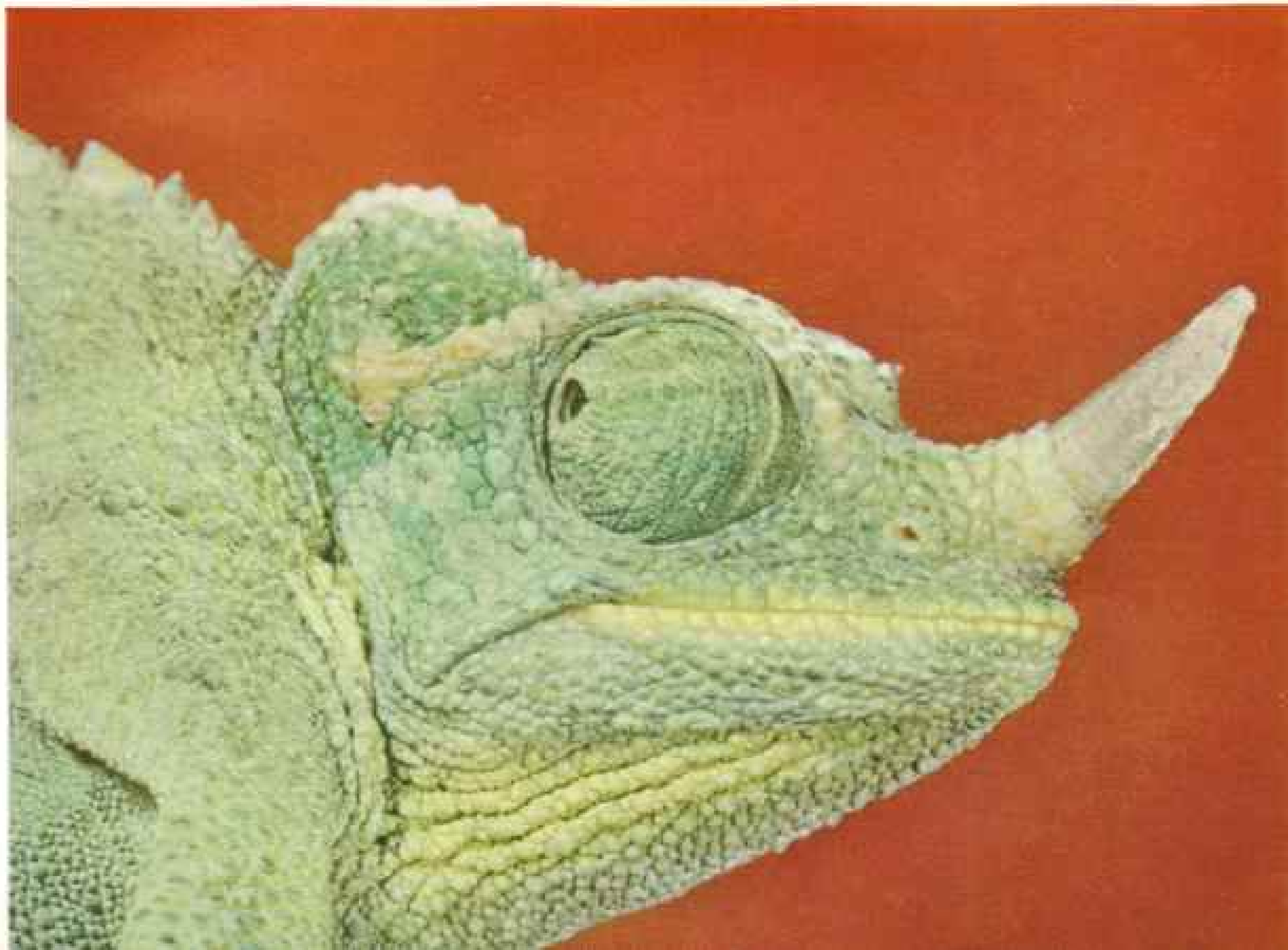

**S-s-s-s! Begone!  
Needle Teeth Back  
Boa's Hissed Threat**

One of the constrictors, or crushing snakes, *Boa constrictor* is not venomous. The broad head tapers to a blunt point. In its native South America the green tree boa lives almost entirely above ground. Half coiled, half looped upon a limb, it lies in ambush for unwary birds, tree frogs, and lizards.

This four-foot-long specimen weighs four pounds.

**↓ Rare Hybrid Bears  
Are Bottle Babies**

Frances and Elizabeth, second-generation hybrid bears, are freaks of nature; the zoo owns the only two in existence.

An Alaskan big brown bear and a polar bear produced the original cross. Geneticists, judging by hybrids like the mule, felt sure the issue would be sterile. These cubs disproved the theory. Like other such mixtures, they have no scientific name of their own.

Nancy Miller here assists the twins in their sixth week of life.

© National Geographic Society

Robert F. Brown and Donald Mohler,  
National Geographic Staff

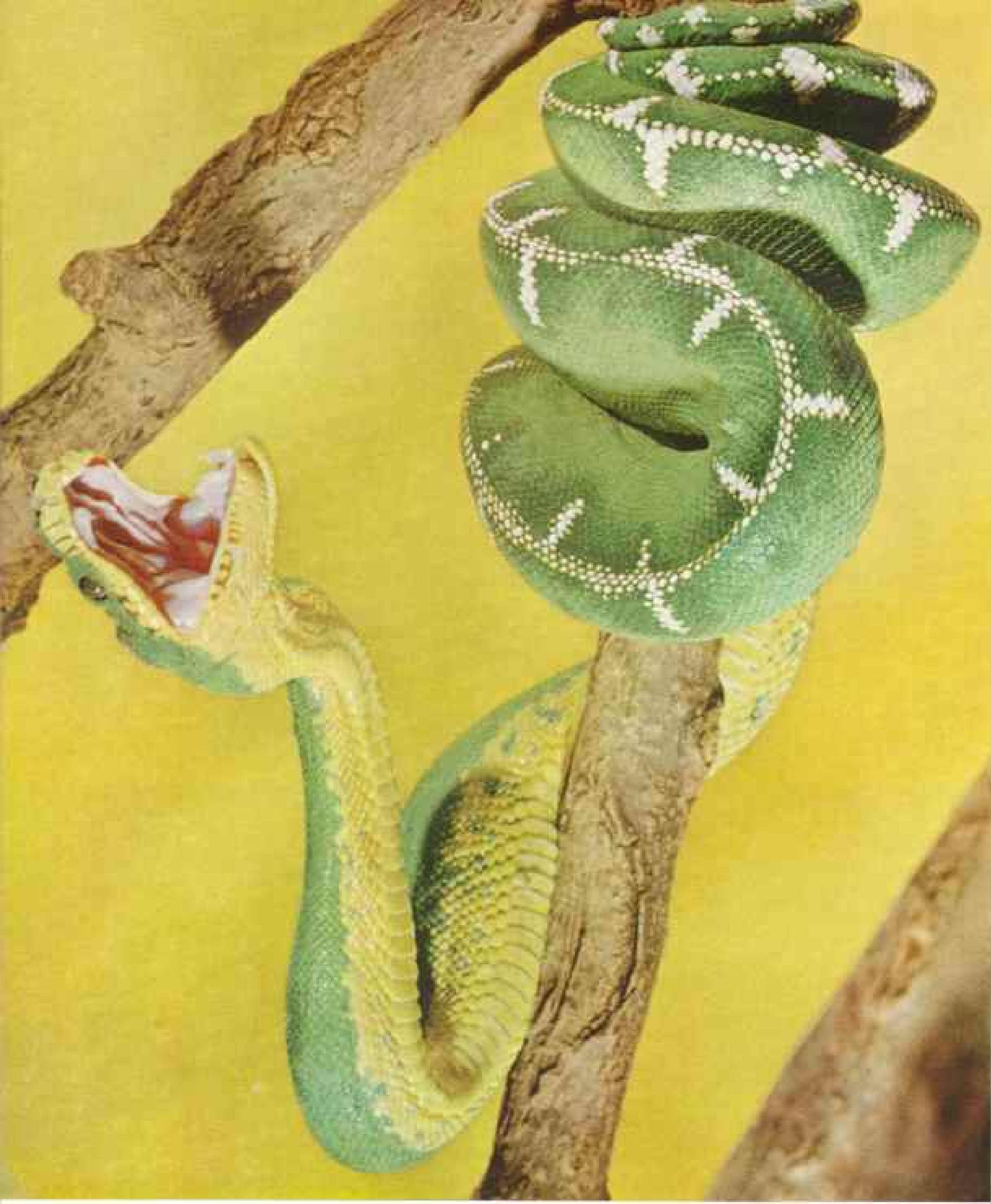





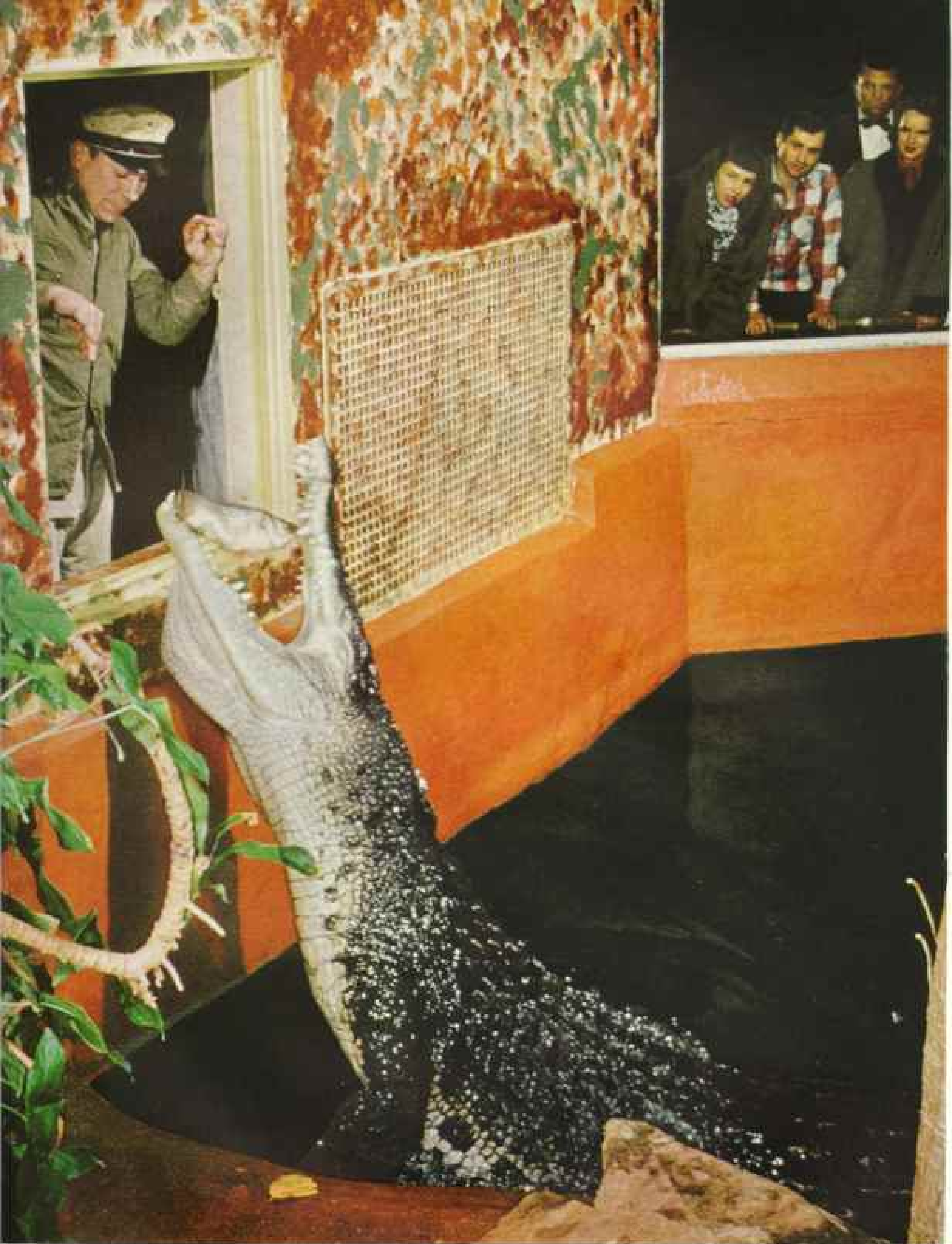

↑ Like a Trout Leaping for a Fly,  
a Crocodile Lunges for Fish

Giant among reptiles, the salt-water crocodile lurks in river mouths from India to Australia. A man-eater, *Crocodylus porosus* can bite off an arm or a leg with one twist. The zoo's specimen stretches 16 feet.

Africa's Spotted Stilt Walker Adores →  
Her 7-foot, 135-pound Infant

Page 517: These two are descendants of giraffes collected by the National Geographic Society-Smithsonian Institution expedition of 1937. Tallest of mammals, *Girafa camelopardalis* may exceed 20 feet.





#### Owl-eyed, Frog-footed Tarsier Clings to a Fountain Pen as to a Jungle Stalk

The Philippine island of Mindanao sends us *Tarsius carbonarius*, a 5-inch, 3½-ounce primate. Pleated ears can be folded shut like slatted blinds. Bulbous pads tip fingers and toes. Eyes fill much of the tarsier's face; their enormous size makes light gathering easier for this nocturnal animal.

### Tiny Mouse Opossum Can Inflict a Bad Bite

Cousin to the North American possum, tropical *Marmosa* carries her young in a pouch. Infants are scarcely larger than grains of rice.

Shrewlike mouse opossums prowl by night. They eat many things, including fruit, insects, and occasionally others of their kind. Their range is southern Mexico to the Amazon.

This captive's jet-black eyes bulge above foxlike muzzle.

### ✦ Sky's Graceful Flyer Is All Thumbs on Land

Other mammals can glide through the air on membranes spread like wings. But only the bat rises like the birds, actually surpassing them in some maneuvers.

A bat's wing is an umbrellalike framework of finger bones covered with thin, elastic skin. The thumb, with its hooklike claw, remains free to cling to supports or crawl along flat surfaces.

A kind of sonar enables the bat to avoid obstacles in its flight path and find its insect prey. Ultrasonic squeaks beamed ahead bounce back to the ears from any solid object.

Some 2,000 kinds are known. This is a hoary bat (*Lasiurus cinereus*), common in North American skies.

© National Geographic Society

Ernest P. Walker

519





Then there's the zebra. Years ago we lent him to the United States Department of Agriculture for experimental breeding with the domestic ass and the horse. Their experts were interested in getting a work animal that would be immune to the African tsetse fly. Unfortunately, though the offspring may have been disease resistant, they were also quite work resistant.

A fantastic example of reverse breeding in a zoo was engineered by Lutz Heck of the Berlin zoo and his brother Heinz of the Munich zoo. I visited Heinz Heck shortly after World War II. Bombers and food shortages had virtually wiped out his once magnificent collection. But, strangely, one of the animals to survive modern man's itch to destroy himself was the most archaic in the zoo: the aurochs, a once extinct breed of cattle whose likeness appears on the walls of many a prehistoric cave.

By a kind of de-evolution, the Hecks over a period of some twenty-five years bred

genetic throwbacks together until they worked their way to the original aurochs. How did they know what an aurochs looked like? Well, they had seen it portrayed—an agile, barrel-chested animal with a light stripe running along its spine—both in prints of the 17th century, the era in which the breed disappeared, and in the early cave drawings.\*

Now, in the middle of gutted Munich, I could see the Hecks' re-creation, lost to the eye of man for three centuries, placidly chewing its cud and gazing with ancient eyes upon the ruined city.

During the period of the worst air raids Heinz Heck moved right into the zoo with his animals, living in a concrete cubicle; through slits he could observe the reactions of his charges under fire.

I have never lived in my zoo. On the other hand, like many a director, I've had quite a

\* See "Lascaux Cave, Cradle of World Art," by Norbert Cochetel, NATIONAL GEOGRAPHIC MAGAZINE, December, 1948.

#### ←Mandrill's Nightmare Face Looks Even Uglier as He Grows Older

Page 520: Most colorful of the baboons, the mandrill roams west African forests from Senegambia to the Congo. Omnivorous, it eats fruits, insects, lizards, small mammals, and birds.

In mature males the teeth grow large and the cheeks develop folds of corrugated skin.

This bearded gargoyle is 6 years old. In later years his nose will turn tomato red, in striking contrast to the bluish cheeks. Beetle brow and fire-tinted eyes round out the fierce portrait of *Mandrillus sphinx*.

→Russell Arundel of Warrenton, Virginia, obtained these baby gorillas in the Belgian Congo in 1955 and presented them to the zoo. Here his son Arthur, who accompanied them to this country, renews relations.

The pair have already outgrown two cages. At maturity, Nikumba, the male (on shoulders), may weigh more than 400 pounds and stand 5½ feet. Moka, the female, will be slightly smaller.

© National Geographic Society

←William W. Campbell, III  
Robert F. Steiner and Donald McLean,  
all National Geographic Staff →





### Baby Elephant, an Inaugural Visitor to Washington, Calls on the Author at Home

Mills Brothers Circus sent Little Miss Burma and a full-grown companion to the Capital to enhance last January's festivities. Parading along Pennsylvania Avenue, the two elephants saluted President Eisenhower in his pavilion before the White House. Earlier, circus owner Jack Mills took Little Miss Burma on a surprise visit to Dr. Mann, an avid circus fan. The apartment building's small elevator groaned beneath its ponderous passenger. Led into a strange hallway, she trumpeted in terror, but once inside the Manns' living room she behaved like a lady. The commotion had a tonic effect on Dr. Mann, who was confined by illness. Here his caller takes sugar from his hand. Rita Sagraves, the beast's custodian, wears her parade costume.

few of my animals come to live with me (page 505). Alexander Woolcott, indeed, once remarked rather testily, "The only reason the Manns don't keep a giraffe is that they don't have a duplex."

Nothing surprises me any more about the kind of pets people keep. I know a New Jersey man who raised a quite lovable hyena. And I once heard of a boy who cherished an oyster which he housed in a jar.

For myself, I prefer something a trifle livelier—say, a lion.

This taste of mine has occasionally caused the management of our cooperative apartment to blink. The board of directors has a strict rule against tenants' entertaining four-legged guests, and when they received a brief note from my wife ("Gentlemen," wrote Lucy, "May I have permission to keep a lion in

the apartment?"), they were knocking at our door in a trice.

Fortunately, they were no more able than I had been to resist the sight of Susan, a tawny little ball, all paws and fur, nestled in Lucy's lap. We kept the lion, which had been callously abandoned by its indifferent mother in the zoo, and raised her until the furniture and my wife's forearms could stand her claws no longer.

At other times we have been host to two tigers, Bobette and Hari; a bear; a cheetah; a kinkajou; a lemur; a four-foot rosy boa; wildcats from Ethiopia; a galago, or bush baby, named Zanzi; an alligator named Charlie Shirt-Tail; and a wart-hog named Junior.

My wife had not exactly prepared herself for these animal invasions of our privacy;

in college, in fact, she took up archery to avoid a course in zoology. But she is resilient. When I showed up at our apartment door with a newborn bear under my shirt, the bear was bawling.

Lucy took one look at it and held up her hand. "Step back a minute, Bill," she sighed. "Let me have a little time to get used to the idea."

Last October I retired. I cleaned the puma bones off my roll-top desk (I'd been meaning to for years), picked up some old circus

posters that seemed to have drifted onto it, and went home.

But from my apartment windows I can still hear the screams of the Brazilian flat-tailed otters, like a hundred hysterical kids just being punished, the booming whoop of the gibbons, the bark of the cavorting seals. And I still get just about as many phone calls from some woman with a sick parakeet, or a farmer who has seen a long white animal with a flat tail that eats sheep and who wants me to identify it, or an indignant taxpayer

### Baby White Rhino, First Ever Displayed in the United States, Gets a Rubdown

Less irascible than its notoriously quick-tempered black relative, the square-lipped rhinoceros dwells only in a few limited areas of central and southern Africa. Biggest of its family, the beast may stand 6½ feet at the shoulder and weigh up to four tons. The front horn may measure five feet in length; three feet is common. Not truly white, the hide is smoky gray. Once nearly extinct, the species now holds its own under rigid protection. Lucy, named for the author's wife, arrived last year from Uganda.

Volkmar Westphal, National Geographic Staff





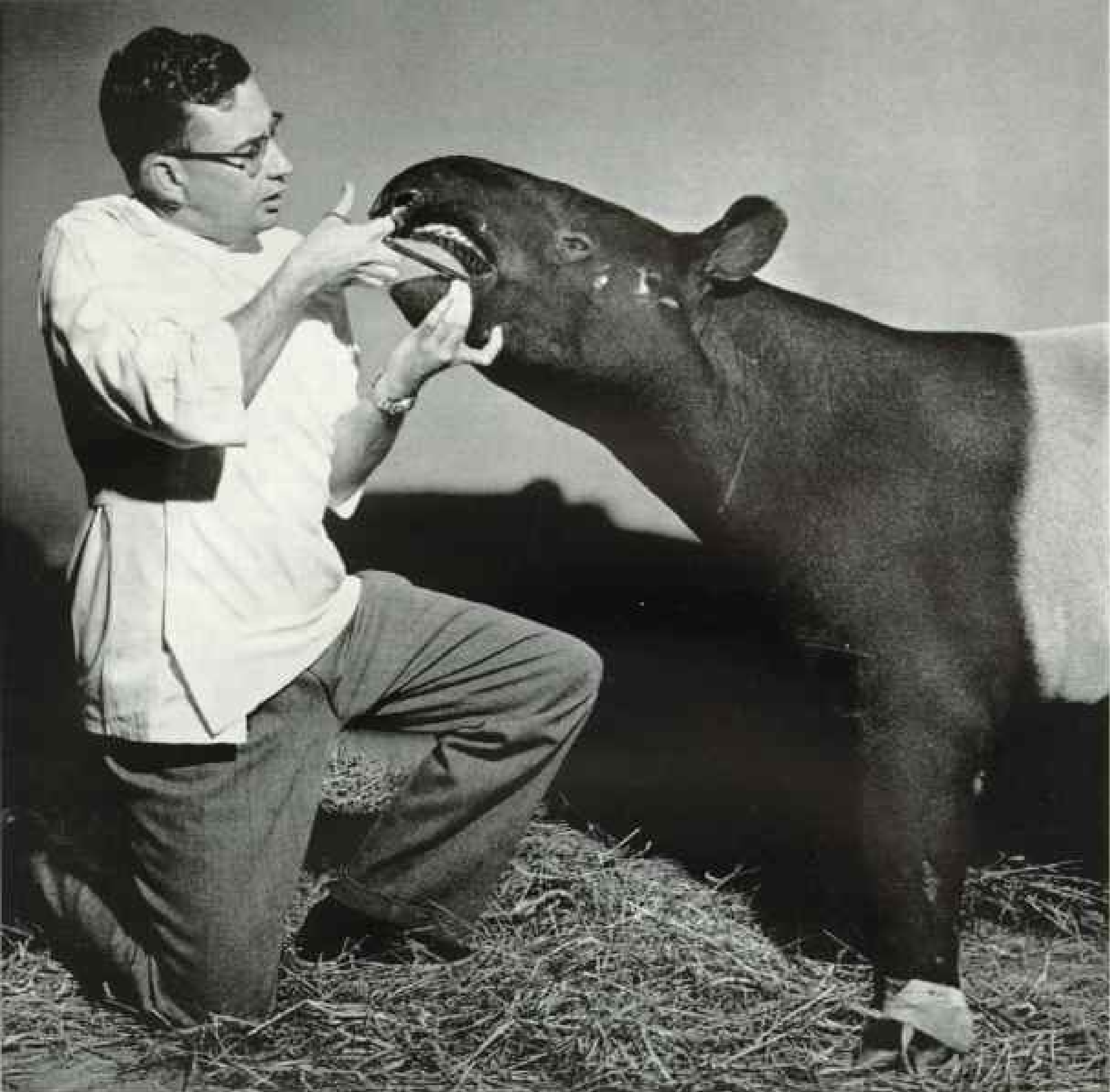

### Sick Tapir, a Docile Patient, Offers a Target for Aureomycin Pills

Malay tapir wears a two-color coat: black with a light-gray swath around the middle. Here Dr. Theodore H. Reed, a veterinarian and acting director of the zoo, shoots capsules into the throat.

who demands I stop the peacocks from screeching so that he can get some sleep.

True, I no longer have to answer on the spot the stock questions of all zoo-goers: "Why does the flamingo stand on one leg?" (I don't know); "Why doesn't the one-horned rhino have a horn?" (He wears it off by rubbing it on the concrete wall); "Why does that boatbill heron in the birdhouse keep watching the water drain?" (He's been waiting for years for a fish to come out; he's an optimist).

Yet I miss even those tired questions and tired answers.

Sitting here now in my apartment, I begin to feel strangely restless. Those young gorillas—I hear they're a bit down in the mouth (page 521). That fine hippopotamus gentleman with a cataract of old age beclouding one eye—could anything possibly be done for him?

And that black leopard who has never deigned to notice me in all the years I've passed his cage—do you suppose he might relent now, at long last, and acknowledge my existence?

I think I'll just stroll over to the zoo and have a look around.

Plants, Animals, and Men Defy Subzero Weather and Bitter Winds,  
Perpetuating Life in the Shadow of the North Pole

BY RUTHERFORD PLATT

*With Illustrations from Photographs by the Author*

**I**N THE Far North there is a world so strange, so different from the one most of us know, that a visit to it is like a trip to another planet. It is a world still in the grip of the Ice Age, which several times during the last million years spread ponderous ice sheets over half of North America.

I saw this world first from the deck of an 88-foot wooden schooner, the *Bowdoin*, coasting the west shores of Greenland (page 526). Two summers I have visited the living Ice Age under sail, a botanist shipping north as a crew member with Rear Adm. Donald B. MacMillan, USNR, one of the last of the pre-Air Age Arctic explorers.\*

**Life Persists Even in Icy Wastes**

Here I have seen what conditions must have been like when the big ice of the last glacial age ground its way as far south as Long Island and the Ohio River. Here, too, I have met people as elemental in their mode of life as the earliest Americans, who huddled in caves against the cold and hunted now-extinct animals.†

From even a few hundred yards offshore the rock and ice empire of the polar regions, far north of the Arctic Circle, seems totally lifeless. It is almost as arid as a desert. A few inches beneath the surface the ground is permanently frozen. There are no springs, no swamps or bogs as we know them, and few level places. The surfaces are dry through much of the year and terribly exposed to freezing winds. Yet life exists, and even thrives, in this icy waste.

When I walked about on shore, I found lichens and mosses, grasses and colorful wildflowers flourishing amid tumbled rock along the face of advancing glacier tongues. Birds wheeled and cried; in clear, frigid ice-melt pools, hundred-legged tadpole shrimps wriggled and darted in urgent instinct to live, out their short life span before their puddles froze once again.

In Arctic summer, 24-hour sunlight bathes this world of paralyzing cold and rocky des-

olation and brings it alive. It was then that I saw it, at the best time for Admiral MacMillan to take us to this land of the big ice.

Through the years MacMillan has made some 30 polar expeditions by ship. He has sailed his rugged little *Bowdoin*, specially built for northern exploration, boldly into the ice pack, cruising uncharted waters merely, as he says, "to learn something."

MacMillan helped organize the supporting parties that made possible Robert E. Peary's successful dash to the Pole in 1908-1909. Now, nearly fifty years later, having gone north again and again, he still looks forward at the age of 83 to sailing once more "to learn something" about the Arctic (page 545).

His expeditions have been sponsored by universities, by the United States Government, and by museums and geographical institutions, including the National Geographic Society.‡ Scientists, college professors, and research students have signed on as crewmen to study the plant life, rocks and fossils, birds, animals, and people of the polar region.

My own goals were three: To see what type of plant life grows at the face of the Greenland glaciers; to visit the site of a fossil forest on the west coast of Greenland near Disko Island; and to find out what natural life exists in the Far North.

**Northward Along Treacherous Shores**

Sailing from Boothbay Harbor, Maine, "Captain Mac" took us along the treacherous shores of Labrador, zigzagging from point to point inside the reefs (map, page 531). Few men living dare bring such a deep-draft ship so close inshore along this coast.

If the skipper of a Newfoundland fishing vessel saw the daring course we set, he

\* See "Far North with 'Captain Mac,'" by Miriam MacMillan, NATIONAL GEOGRAPHIC MAGAZINE, October, 1951.

† See, in the NATIONAL GEOGRAPHIC MAGAZINE, "Ice Age Man, the First American," by Thomas R. Henry, December, 1955.

‡ See "The Society's Hubbard Medal Awarded to Commander MacMillan," NATIONAL GEOGRAPHIC MAGAZINE, April, 1953.

## Greenland's Lichened Cliffs Overhang the Arctic-voyaging *Bowdoin*

As companion of explorer Rear Adm. Donald B. MacMillan, the author made a botanical expedition to the Arctic aboard the stout little ice-defying schooner. Here *Bowdoin* rides to her anchor near Etah, an abandoned Eskimo village at 78° 20' north, 800 miles from the Pole. Icy mountains of Ellesmere Island loom across Smith Sound.

Rocks derive their rust color from lichens, a strange partnership of fungus and alga, whose acid-bearing growths hold fast to glass-hard boulders.

Lichens have no need of soil, but, preparing it, lay the cornerstone for flowers and trees. They are the plant world's pioneers, bringing life where none existed.

## Life Cycle of Polar Plants Is Swift; They Pack Three Seasons into One

No weaklings grow up; the North tolerates only sturdy individuals. The number of species dwindles rapidly as one moves north; Greenland has only about 350. By comparison, the 69-square-mile District of Columbia has five times as many.

Page 527, lower; Fruit (left) and flower of *Pedicularis arctica*. *Pedicularis* literally means "pertaining to lice." Its common name is lousewort. One explanation given for the uncomplimentary tag is that the ancients used lousewort seeds in hope of destroying lice.

↓ These enlarged portraits show the flower (left) and fruit of *Sedum roseum*. *Sedum* is a genus of wide-ranging northern herbs.

© National Geographic Society

526

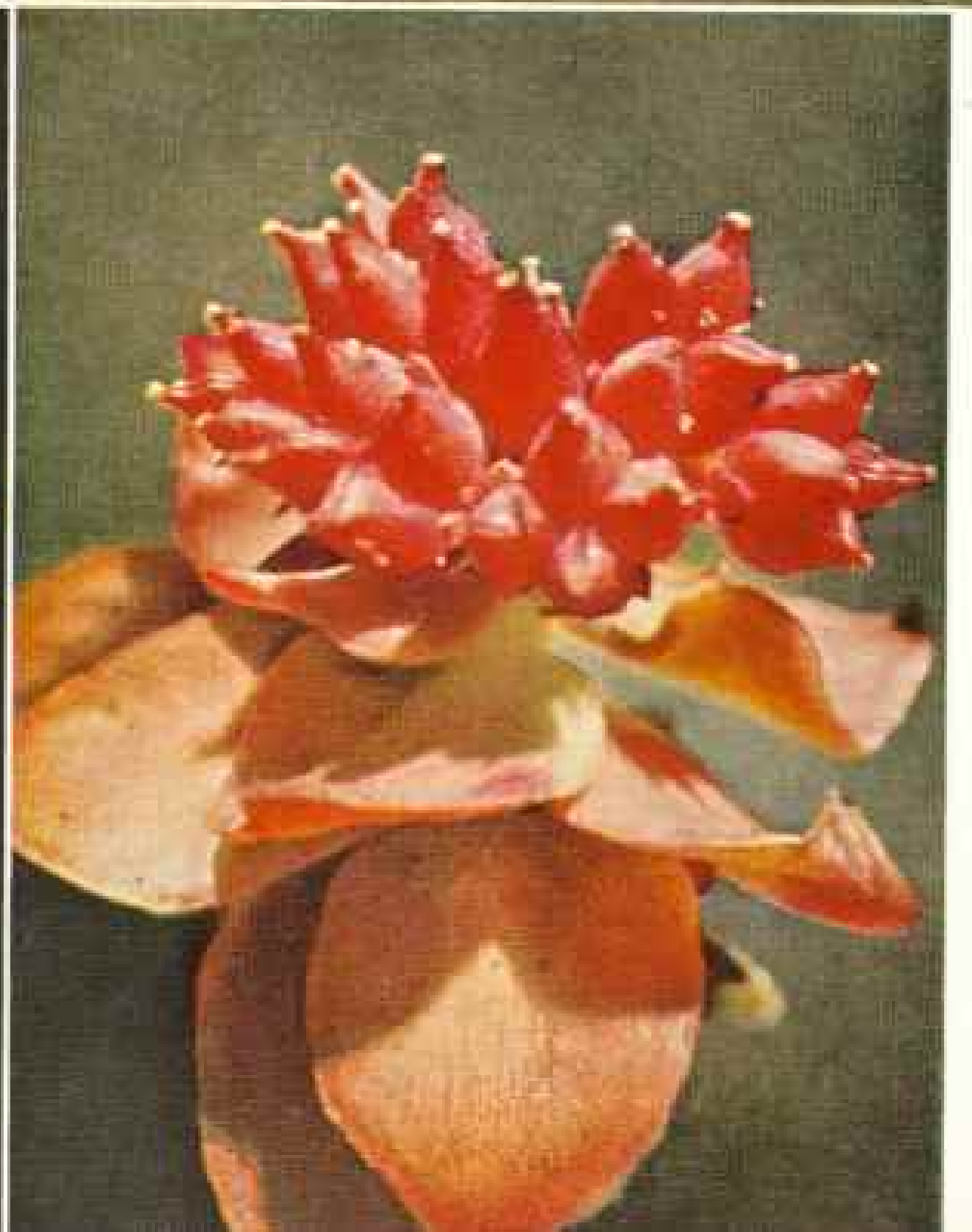

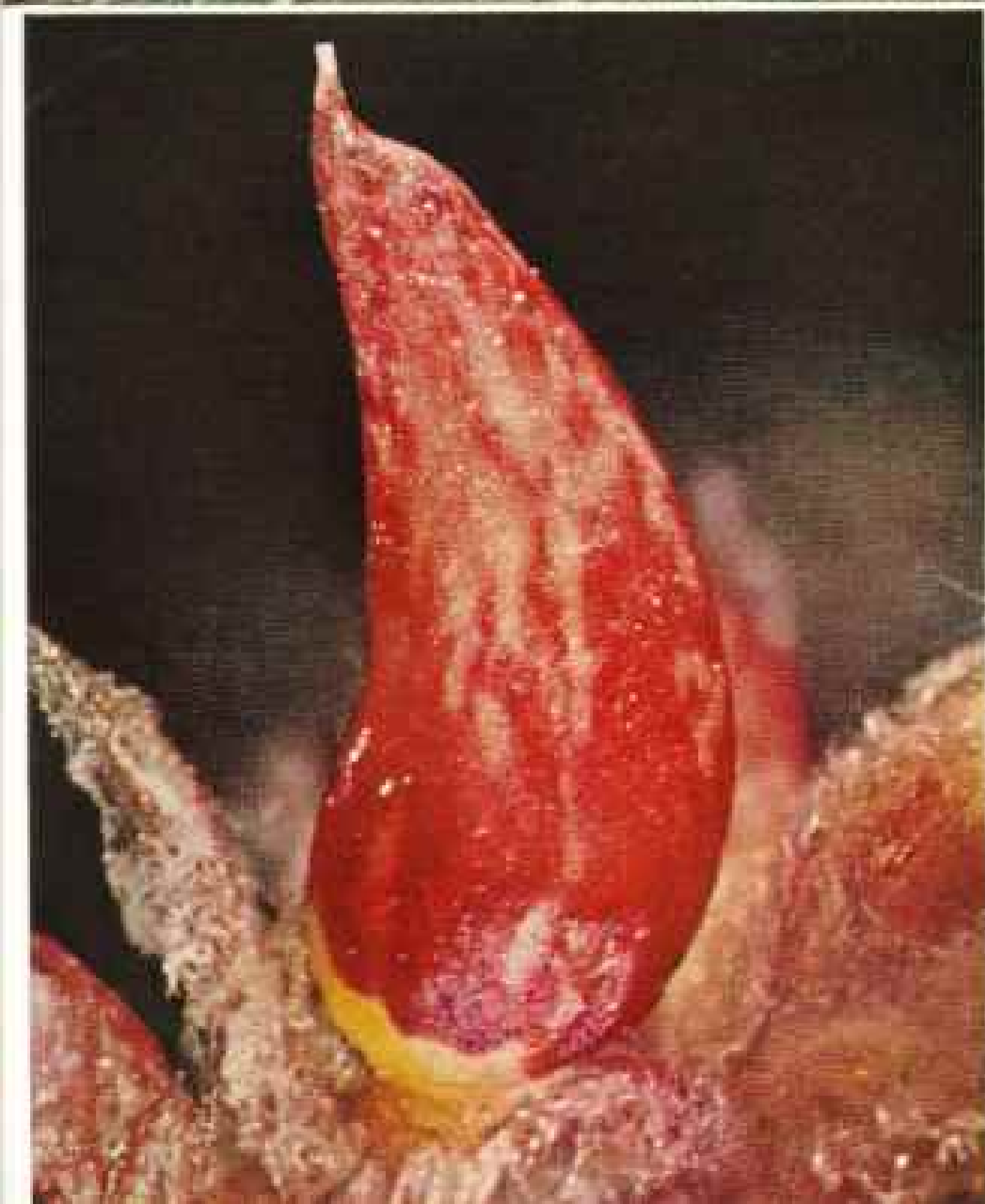

merely shook his head and said, "There goes Mac!" And if a bad storm had blown up, that same fisherman would have known his best course was to follow Mac in between the breakers to safety.

But even Mac's luck doesn't always hold. Suddenly one day I staggered as the ship gave a lurch, a bounce, a cruel crunch down beneath the keel. *Bowdoin* stopped short, listed, and hung as though impaled, like a great white bird that has been shot and died on the water.

An ordinary ship might have broken in two, but *Bowdoin* is built to withstand far harder shocks. Her white oak ribs are doubled, her planking three-inch oak under two inches of Australian ironwood; her bow is shod with steel; and 22 tons of cement are molded into her frame to strengthen it.

Captain Mac ordered cargo and crew shifted as far forward as possible. With all sail set, engine throttle wide open, the schooner nodded, heeled, slowly revolved, and at last slid away from the hidden rock unscathed. The skipper calmly noted the obstruction on his personal chart, and we were once more under way.

#### *Bowdoin* Overrides Floating Ice

MacMillan built *Bowdoin* after years of Arctic experience showed him what a ship needed to survive. Not only is she specially reinforced within, but her hull is curved and rounded so she can be rocked in any direction to get her off reefs. Her bow is cut under so that when it strikes floating ice the whole ship rides up and across it, instead of smashing against the obstruction.

When ice squeezes *Bowdoin's* sides with irresistible pressure, the curved shape of the schooner will permit her to rise, as an orange seed escapes the squeeze of your fingers.

In this unique ship MacMillan has sailed the cold coasts of Baffin and Ellesmere Islands and the rocky shores of west Greenland. He has spent a lifetime locating unknown reefs and islands and bringing back vital new information to be added to the charts published by the U. S. Navy Hydrographic Office.\*

From Cape Mugford, Labrador, we set our course northeast toward Greenland. In Davis Strait, between Baffin Island and Greenland, lies some of the world's stormiest water.

Eventually, as *Bowdoin* heads north, we sight a low white line on the horizon resem-

bling a thin horizontal cloud. Then the sea strangely subsides, the swells are gone, and the ship sails in smooth water.

Closer at hand the white line takes the vivid form of tumbled ice pans stretching to the horizon, barring the way along the western side of Davis Strait. By sailing eastward, however, we can skirt the ice pack and proceed on northward.

#### Greenland Lives in the Ice Age

The ice pack lay far to the west and north when *Bowdoin* raised the coast of Greenland. We sailed on northward and at latitude 66° 30' crossed the invisible line of the Arctic Circle. From there, north to the Pole, stretched a vast region of the living Ice Age.

At times we could glimpse from far offshore the Greenland Icecap, a gleaming white line hanging between the gray of the coastal cliffs and the deep blue of the sky. Though blanketing most of the big island, it is but a remnant of the ice that some 25,000 years ago covered large areas not only of North America, but of Europe and Asia as well.†

Along the faces of Greenland glaciers today, in bitter struggle against the cold, grow probably the same kinds of plants that flourished along the faces of those great ice masses so long ago.

Among the first plants to grow on any ice-scoured land are the humble lichens. That curious type of plant life seems to be immune to cold and exposure. Lichens produce an acid that can etch the surface of the hardest rock, helping break it down into soil.

#### Lichens Clothe Gray Boulders

The boulders along the fronts of the Greenland glaciers are copiously splashed with lichens. Moss grows in depressions where moisture gathers. Then come grasses, sedges, and finally the wildflowers. These are only a few inches high, but they flourish in the bright sunlight.

Even in far-northern Greenland I was able to fill my plant-collecting box over and over with brilliant, healthy wildflowers in a few minutes of picking. Besides chickweed and saxifrage, I found fireweed, buttercup, poppy, and Arctic rose (*Dryas*).

\* See "Charting Our Sea and Air Lanes," by Stuart E. Jones, NATIONAL GEOGRAPHIC MAGAZINE, February, 1957.

† See, in the NATIONAL GEOGRAPHIC MAGAZINE, "Wringing Secrets from Greenland's Icecap," by Paul-Emile Victor, January, 1956.



**Fireweed, the Temperate Zone's Four-foot Giant, Becomes the Arctic's Four-inch Pygmy**

Plants of the living Ice Age tend to remain small owing to lack of water and soil and the fierce intensity of the Arctic sun, which in summer shines around the clock.

Showiest of northern flowers, this fireweed, *Epilobium latifolium*, grows above fossils of one of the world's earliest known deciduous forests, near Disko Island, Greenland. Its ancestral forms may have marched north out of Ice Age America behind retreating glaciers. Fireweed is so named because it often springs up in ruins left by fire.



530

### Greenland Yields Plants to the Author's Collecting Box

Rutherford Platt has combed North America, Europe, and Asia in search of material for his books and articles on natural history. Twice he accompanied Admiral MacMillan on *Bowdoin's* Arctic voyages.

Many of the plants grow not as a continuous ground cover but scattered in cracks of the rock or snuggled under the curves of boulders. Their leaves are compact rosettes, usually forming either "pincushion" clumps or mats growing flat on the ground.

Clumps, seemingly springing from bare rock, usually have one central taproot that penetrates between boulders or pushes into a crack with amazing power. A mat may be a foot across and bear several dozen flowers, yet it has only that one thick root as a mighty anchor.

There are no trees in Arctic Greenland, but woody plants have already invaded spots at the glacier fronts. Willow and birch grow in mats sometimes several feet across, as flat as though a steamroller had ironed them out.

Bilberry and crowberry also grow there as flat as pancakes (page 538).

Possibly some pioneer trees of our own northeastern forests also were flat thousands of years ago, when they first sprang up in the wake of the receding glaciers. Tall trees—maples, elms, oaks, and poplars—marched north behind the retreating cold from their Ice Age refuge in the southern Appalachian Mountains.

### Arctic Had Tall Trees

There is evidence that Greenland, too, once had tall forests of trees much like those of the Appalachians. Disko Island, lying off the west coast of Greenland, is separated from the mainland by Disko Bay and a narrow arm of sea known as the Vaigat. Snow-capped mountains face each other across the water.

On the mainland side a great ravine has been deepened by melt water running down from the icecap. Far down in this ravine are exposed layers of sandstone that have been buried for millions of years, and in

them are fossils of ancient hardwood forests. From *Bowdoin* I went ashore here to read the story of these trees.

For a time we found no evidence of fossils. Then as we worked farther up the ravine the thin brittle layers showed definite markings. Almost every flake bore an impression. It was easy to imagine the relationship of the designs to part of a sassafras leaf, a sycamore, a fig. In one place we found impressions of what I took to be elm seeds, in another the marks of little pods, in still another the outline of roots in the shale.

We were looking at the pages of a story that recorded the existence of deciduous trees where now only the willow and the birch grow as gnarled pygmies. It was a curious, eerie moment in the light of the midnight sun.

We made a pile of rock specimens at the head of the beach, then took the dinghy back to the schooner to get more help and a warming cup of coffee. We never returned. A storm swirled off the icecap, and icebergs began to crowd the ship. Seven years later, when we tried to land in the Vaigat again to recover our pile of fossils, ice and storms drove us off. That single glimpse into the dim past was all that was given us.

Though the wildflowers at the face of the big ice in Greenland are as lusty and freely blooming as any in the world, they, too, are only pygmies. The farther north we voyaged, the smaller were the plants we found.

The Arctic rose and buttercup are an inch

or so high. Chickweed and mustard may be full grown and yet less than an inch tall. The entire flora is mostly below ankle height (pages 543 and 544).

In this world of immense scale, in which an iceberg half a mile across is a mere speck and an 88-foot schooner with its tall masts seems to vanish, the plant kingdom has become diminutive. It is startling to see a plant like our fireweed producing a full-sized bloom on a stem only four inches tall (page 529).

The growing season lasts only a matter of weeks, and through much or all of this period the sun swings continuously above the horizon. This continuous bright light is one

(Continued on page 537)

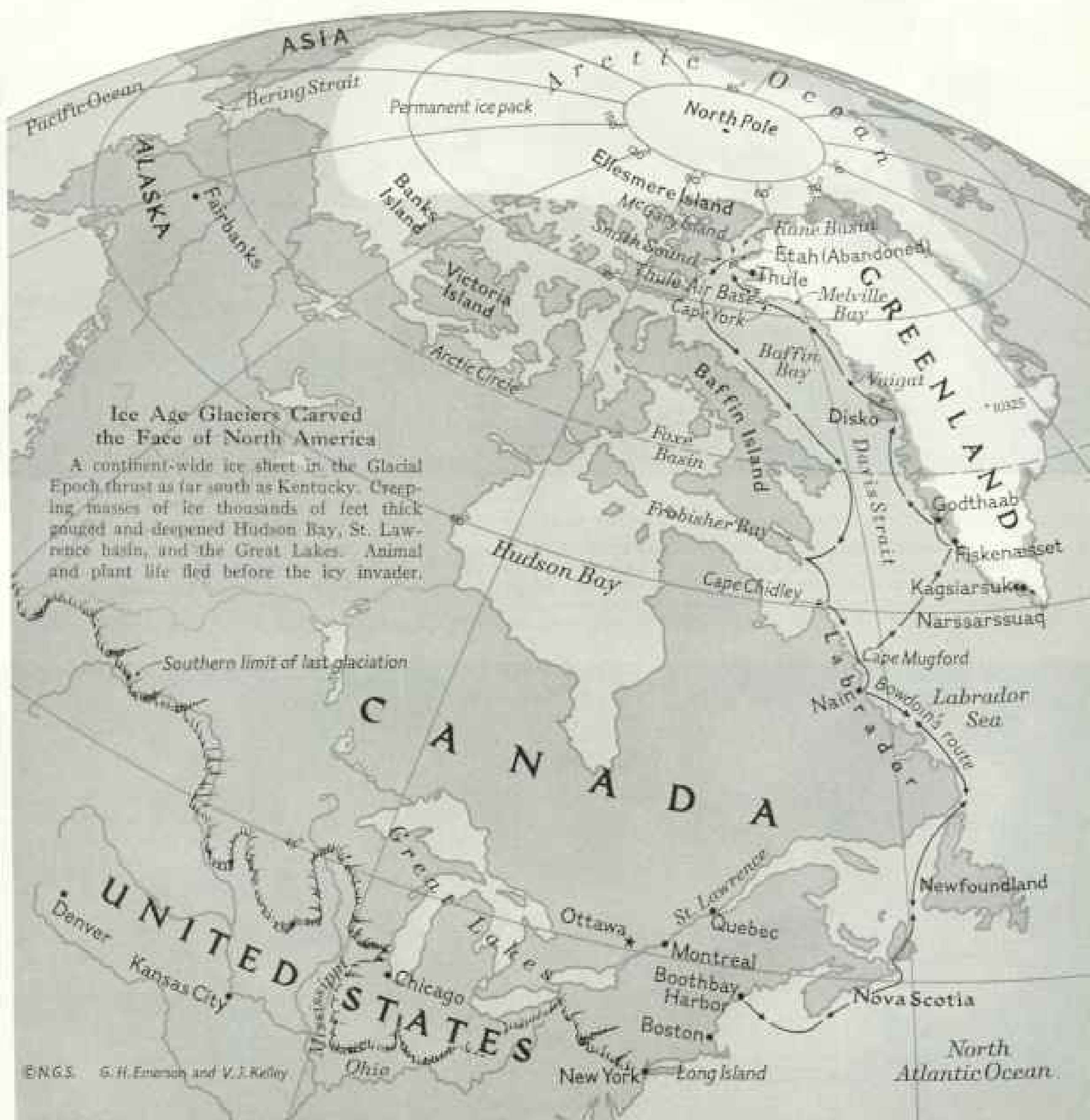





© National Geographic Society

532

Kulachitane by Andrew H. Brown, National Geographic Staff

### Greenlanders Tread Ruins of a Church Built Nine Centuries Ago by Europe's Lost Colony

Norsemen under Eric the Red colonized southern Greenland in the late 10th century. Settlers clung to their farms for 500 years; then supply ships from home unaccountably ceased to call. Visitors half a century later found a solitary skeleton here near the present-day village of Kagsirsuik. Legend says Eskimo invaders from the north killed the last starved and crippled colonists.

↓ Silverweed (*Potentilla anserina*) on left and saxifrage (*Saxifraga cernua*) flourish in the brief summer.





↑ Arctic Willow in Fruit

Twin red fruits like tiny gourds identify *Salix arctica*.

Flower portraits on this and facing page are enlarged. Some are half an inch in diameter, others even smaller.

↓ Arctic knotweed (*Polygonum viviparum*) grows bulbils instead of seeds.

533



↓ Miniature Blossoms Defy the Inhospitable Arctic

Eyebright (*Euphrasia arctica*) at left and opposite-leaved saxifrage (*Saxifraga oppositifolia*) get their moisture largely from thaw water. Like other flowering plants, they encase their seeds for protection—one of the vegetable kingdom's greatest advances. More primitive plants, such as pines, bear naked seeds. Ferns and mosses scatter spores.





534

### Eskimos Raise Prefabricated Houses Beside Inglefield Bay, Greenland



When jet planes from the United States airbase at Thule frightened away game animals, the Danish Government helped the polar Eskimos move 64 miles north to a site on Inglefield Bay, where seal, walrus, and narwhal were plentiful.

Workers here assemble buildings prefabricated in Denmark, the mother country. Steel posts on right will support the village's boxed-in water and steam pipes. Glaciers across the bay force a passage between the mountains.

#### ← Young Diner Slices a Tidbit from His Plug of Narwhal Skin

The male narwhal, a small whale, has a long spiral tusk growing out of its upper jaw, almost invariably the left side. Medieval Europeans mistook the javelinlike armament for the horn of the mythical unicorn. Scientists still puzzle over the spear's function.

Eskimos seek the narwhal in summer, harpooning the beast as it rises to breathe amid floe ice. They especially relish the crunchy skin, which they call *muktuk*.

→ Eyes bright with wonder, three Greenland girls admire their first whistling kettle. Mous calls chinks in the wall of their home on Disko Bay.

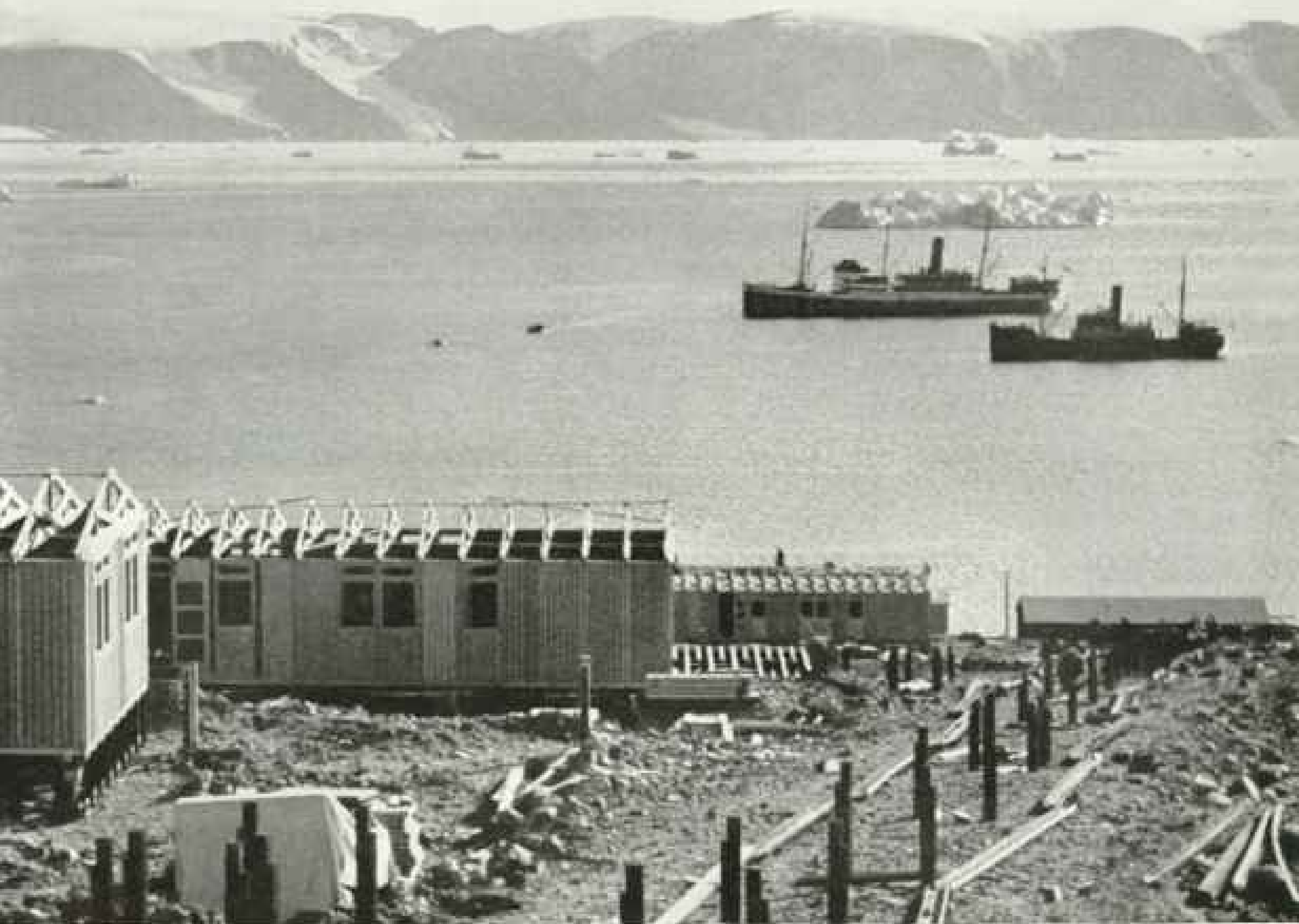

535

Arthur H. Brown, National Geographic Staff

Icebergs, Offspring of Glaciers, Present a Shipping Hazard Even in August





**Labrador Plants, Enjoying Moisture and Three Months' Summer Sun, Approach Normal Size**

These plants are counterparts of many alpiners. Found at Nain, a coastal village, they grew in patches. Farther north they would most likely appear as isolated individuals. Top panel: Lapland rhododendron (*R. lapponicum*) and vetch (*Astragalus alpinus*). Center: Arctic bunchberry (*Cornus suecica*) and a capsuled fruit of Labrador tea (*Ledum palustre*). Below: Flowers of Labrador willow (*Salix*) and a bluebell (*Campanula uniflora*).

of the factors accounting for the small size of the plants; for reasons not thoroughly understood, too much sunlight tends to dwarf plants. Lack of available water and the scarceness of the soil also stunt growth.

Illumination is increased by reflection from rock, sea, snow, and ice. Bright light stimulates blossoming. The whole life cycle of every polar plant is amazingly fast. Fall foliage is bright by the first week of August.

#### Plants Make Their Own Soil

There is almost no soil under the brilliant polar wildflowers. A plant gradually grows a bigger and bigger cushion for itself from its own leaves of previous years. The rate of decay is very slow. Ten years of leaves may be built into a cushion. They are brown and damp, but they are still attached to the crown of the taproot and retain their original leaf-shapes. This mulch prevents evaporation and holds moisture at the precise spot where the plant needs it.

Rain is negligible during the Arctic summer, and what little there is promptly drains off among the boulders. Snowfall is surprisingly light in the rocky coastal fringe of Greenland. The scant snow that does fall, though often borne away like dry dust in the tremendous winds, is one source of water upon which the summer plants depend. Most moisture comes from the melting of ice and frost in the top few inches of the ground, warmed by summer sunlight.

In the interior of Greenland the snows of uncounted centuries have compressed to form a dome-shaped mass of ice some two miles thick near its center, covering four-fifths of the vast island. This dome of ice slopes down toward the coast, pressing against the mountains that rim Greenland like the edge of a mighty bowl.

Through valleys and ravines between these mountains flow rivers of ice, pushed from behind by the tremendous pressure of the interior (page 539). The great glaciers wind gracefully downward, following the contours of the mountainsides like curving white fingers, and many reach the sea.

During the Arctic summer the sun melts the surface of the glaciers, releasing water locked as ice in Greenland's interior for thousands of years. Torrential streams and cataracts plunge downward over ice and rock to the sea. They may cut deep chasms or form summer lakes, but they do plant life little good.

The walls of the Greenland fjords we visited were often sheer rock a thousand feet and more in height, and the deep cold sea water revealed soundings down to 500 fathoms (3,000 feet). Into this water plunge tips of the white fingers of ice curving down from the inland dome.

Since ice is buoyant in water, the finger of the glacier bends upward, while the relentless thrust from the interior is downward. Finally the tip of the glacier, uplifted by the sea, suddenly breaks off with a roar like that of a huge cannon, and a berg is calved.

Many times as *Bowdoin* sailed along the Greenland coast, in and out of great fjords, I heard echoes of this calving booming from the rock cliffs. The water, a moment before as smooth as glass, seethed and crashed around the revolving mass of a fresh berg. Presently the ponderous undulation would subside as the berg reached equilibrium and loomed silently among the flock of other crystal monsters as they slowly drifted out of the fjord.

When an iceberg escapes from its Arctic world into the North Atlantic ship lanes, it becomes a menace like a terrible rock. But the navigator who sees icebergs by the hundreds in far-northern waters may steer close to them in daylight, knowing that uncharted water is deep where a tall berg is afloat.

#### Icebergs Stagger the Imagination

In a fleet of bergs the imagination can discover every figure in geometry, every curve, every symbol of art—in countless combinations. Here is the classical Pegasus with tail flying, neck arched, hoofs churning the water. Here is a great turtle on its back with four legs lifted up into the air.

Here is a minaret atop a mountain, with a ravine, talus slope, and a meadow—all mounted on a float with a cruiser bow. Look again from another angle, and the iceberg has become a mastodon with an enormous trunk, or a giant mushroom, a swan, or the rectangular tent of a desert sheik.

A mathematician can delight in an iceberg, finding there a demonstration of the infinite possibilities of ratio and proportion. The painter beholds tints beyond imagination. The ponderous material is aglow with auroras of blue and white and so lucid that it is shot through with spectral tints of indigo, emerald, sapphire, gold, and rose.

In the polar region the natural world domi-



### Wild Fruit Paints Labrador Barrens

Flower (above) and fruit (below) of the bilberry (*Vaccinium uliginosum*) suggest its near relative, our native blueberry.

Bottom of page: Foliage (left) and dark fruit of the crowberry (*Empetrum nigrum*) decorate landscapes in northern Canada and Greenland.

538





539

### A Narssarssuaq Glacier Melts and Dies

Many glaciers break off into the sea, producing icebergs. One of the so-called dead glaciers, this icy stream thaws before reaching the ocean. As brittle as glass yet as pliant as tooth paste, it ends near the United States airbase at Narssarssuaq.

→ Mountain cranberry (*Vaccinium vitis-idaea*) grows on stormy Cape Chidley at Labrador's northernmost point. Berrypickers are so few and the bog is so remote that the crop is seldom sampled by man. These sparkling red berries, enlarged about six diameters, are smaller than their relatives in the Temperate Zone.

© National Geographic Society

Andrew H. Brown, National  
Geographic Staff (above)





nates in its untouched grandeur. Man scarcely is noticeable in the scale of the scenery. He and his habitations are infinitesimal specks. Man would be called, in a naturalist's handbook of the polar North, "rare."

Yet men are there. For centuries they have survived amid the harshness and immensity of this Ice Age world. Before the first English explorers sailed through Davis Strait and north across Baffin and Melville Bays, there were Eskimos living among the rocky fjords north of 76° latitude. When Sir John Ross first found the polar Eskimos at Cape York in 1818, they were more surprised than he. They had thought themselves the only people in the world (page 542).

#### Air Age Comes to the Eskimos

About 300 polar Eskimos remain today in far northwest Greenland. Within the past five years the Air Age has come literally to their doorstep, for close to old Thule, their historic settlement north of Cape York, the United States has built the largest airbase in Greenland.\*

In turn the Danish Government, to protect the Eskimos, has made a new Thule for them 64 miles farther north. This new village has wooden houses, central steam heat and electricity, a school and hospital, and other amenities of civilization (page 534).

Yet in its basic characteristics the way of life of the polar Eskimos is still much as it was when they were isolated from the outside world. They still hunt walrus and seal, polar bear and narwhal, though now they may do it from motorboats instead of kayaks, and use guns instead of harpoons.

When I first saw Thule, the airfield had just been started. The Eskimo settlement was difficult to pick out against the rugged, rocky background. Even through binoculars, the primitive stone-and-sod huts seemed merely boulders reflecting the sunlight.

The village clung together as if against the elements. Among the huts lay piles of fish heads and entrails, a patch of grass, a seal carcass, harpoons, sealskin bladders, and kayaks.

These people, depending for survival upon the sea and upon hunting musk ox, reindeer, and birds, are used to seasonal moves. Summer or winter they travel to better hunting grounds, living in summer in sealskin tents. The average settlement numbers only 10 to 20 people.

Polar Eskimos do not cultivate crops, nor do they normally eat plants, although when starving they may live on seaweeds. Both children and grownups eat some succulent wild plants as a special treat.

Depending only on themselves, their dog teams, harpoons, and kayaks, the polar Eskimos attained an equilibrium of life not imposed by other men, but adapted to natural conditions. They had no authorities, no taxes. Every one shared alike; if one man lost his dog team, each family gave him a dog, and he was well equipped again.

Polar Eskimos have short arms, short legs, and tiny feet. Strangely, when working on something on the ground they usually bend at the waist, keeping the knees straight.

Life is changing fast for these people. When I sailed with *Bowdoin* the second time to Thule, radio towers rose high above great hangars, and ships lay moored to a long pier in the bay where the Eskimos once hunted walrus. The sound of jet planes screaming from the runway of the huge airfield, scaring away all wildlife, was one of the reasons for moving the Eskimos to a new village farther north.

The airmen, with all their modern facilities, conveniences, and abilities, can remain in that far-northern outpost only by constant supply and support from the civilized outer world. The Eskimos require very little—their heritage makes them masters of a kingdom of ice and cold sea.

#### Birds and Flowers Live amid Rock

All along the steep coast, as *Bowdoin* sailed on north from the Thule area, I went ashore to explore for plants. At one spot, on a steep talus slope of loose boulders, I heard a strange sound, a shrill cooing and piping. It came from thousands of little auks, nesting among the gray boulders.

The Eskimos catch these birds for food, eating them raw or boiled, or freezing them in sealskin bags for future need. They climb the cliffs above nesting places and scoop in the birds with a net on the end of a long pole.

In Smith Sound, where we found the pack ice sufficiently open for navigation, we came to a rock, only a few acres in area, known as McGary Island. It is low, like the back of

(Continued on page 545)

\* See "Weather from the White North," by Andrew H. Brown, NATIONAL GEOGRAPHIC MAGAZINE, April, 1955.



541

↑ **Nature's Brilliant Cushion:  
a Greenland Rock Garden**

During the Temperate Zone's spring and fall the Far North remains locked in cold, but from June to August brilliant sunlight floods the land. Vegetation then fairly explodes from the ground. Snow scarcely melts before blooms are out. The bright sunshine is used to turn carbon dioxide and water into plant food; even the light reflected by ice and rocks is soaked up.

Shinleaf (*Pyrola grandiflora*), moss plant (*Cassiope hypnoides*), and fireweed here mingle on Disko Island. Anchored to cracks in rock, they exist with little soil or humus.

**Algae in a Glacial Brook Wave →  
Sea-green Tresses**

Ages ago the fresh-water alga developed the magic leaf-green of chlorophyll, nature's means of using solar energy to produce food. Alga's second triumph was development of sexual reproduction by division and recombination of chromosomes, the basic processes in transmitting hereditary characteristics. Other fresh-water plants borrowed the alga's secrets, passing them to descendants on land.

Hundreds of millions of years have failed to alter the humble alga's appearance. For all its part in the development of higher-order plants, it remains unchanged.

© National Geographic Society





© National Geographic Society

542

### Polar Eskimos in Bearskin Pants and Sealskin Boots Welcome *Bovidoin* to Northern Greenland

Discovered in 1818, this "lost tribe" was surprised to learn its members were not the only people in the world. Despite a brutal climate and primitive living conditions, their health was excellent. Here the schooner adroitly tugs up to rocks at Etah.

In August the Treeless Arctic Dresses Up in Fall Foliage. Tiny Plants, Hiding in Crannies, Glean Like October's Maples

Top, left: Berries and leaves of bearberry (*Arctostaphylos alpina*) from Baffin Island. Center and right: Arid north Greenland produces two saxifrages with cactus-like leaves. Below, left: Arctic willow's oval leaf. Center: Leaves of sedum form an iridescent rose. Right: *Cochlearia officinalis*, a mustard. (All enlarged.)

543

© National Geographic Society

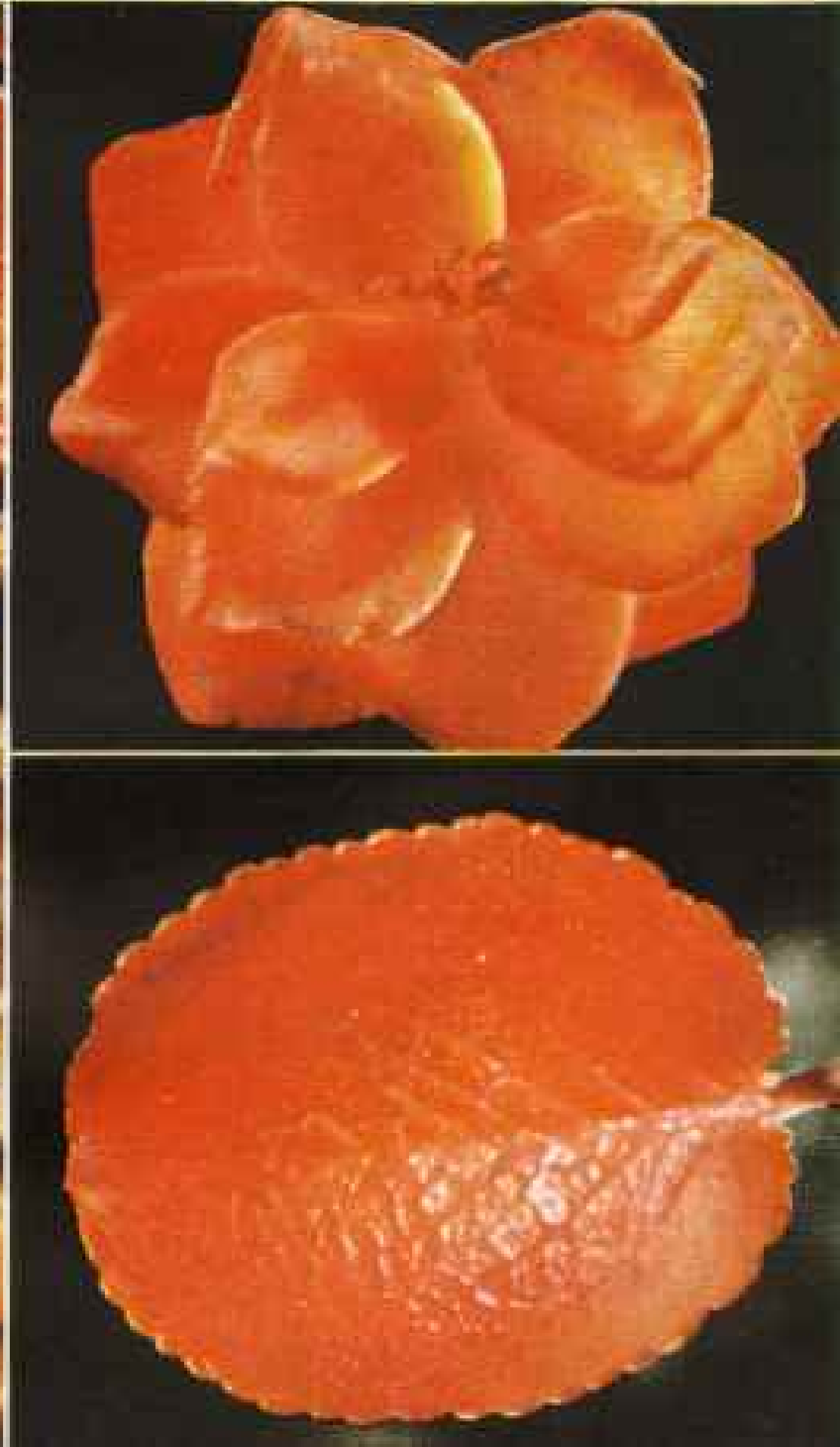

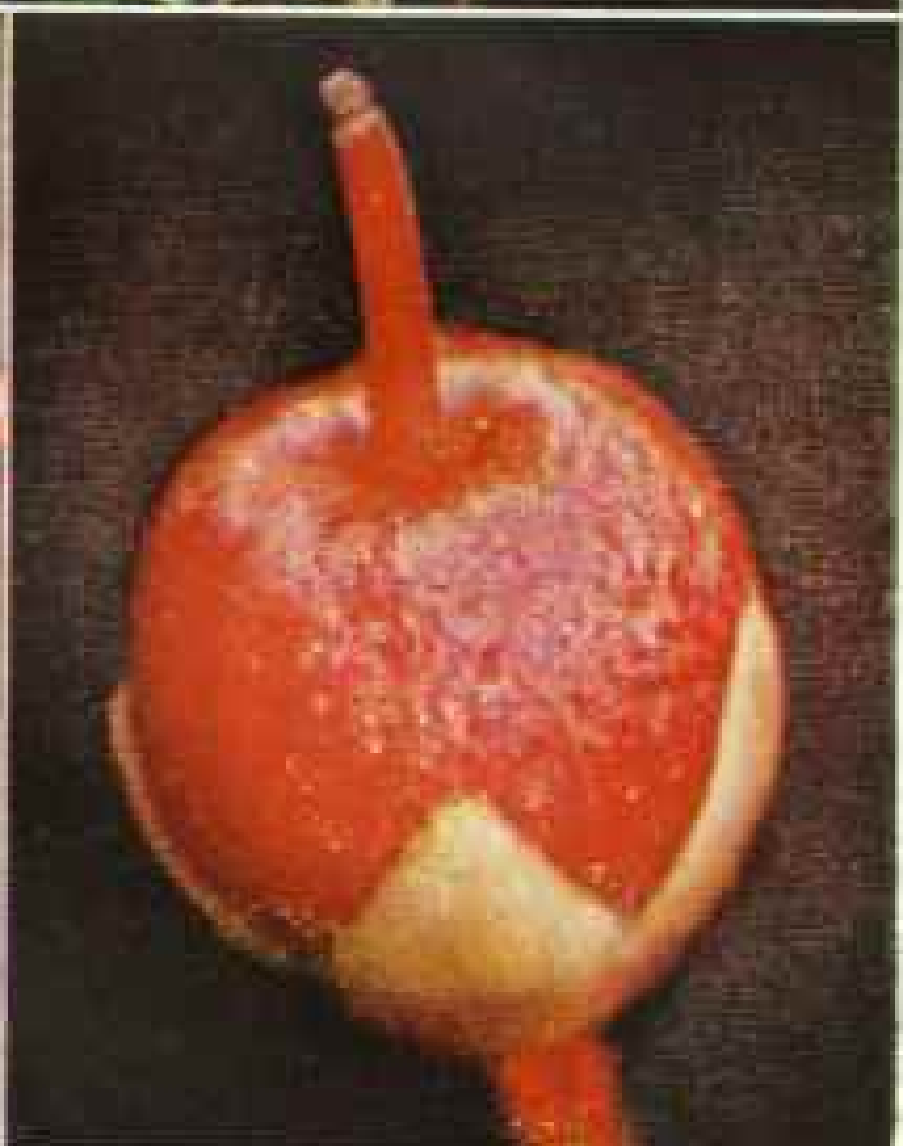

### Some North-polar Flowers Have Southern Kinsmen in the Distant Himalayas

Top panel: Bud and blossom of the Arctic rose (*Dryas integrifolia*), whose stem rises barely two inches. Middle panel, left: The bulbil of *Saxifraga flagellaris*, that grows at the end of a slender runner (below, left). Members of the same species thrive in the frosty Himalayas; they must have traveled from a common source. Middle, right: Fruit and (below) flower of *Cassiope tetragona*, found in the shelter of boulders. (All enlarged.)

a whale, smooth and with no obstructions to cast shadows. The sun shines on it directly and steadily 24 hours a day for about four months of the year. During the rest of the time it lies in twilight or utter darkness. I could not imagine a more exposed and bitter location for wildflowers, yet they grow here. It is an amazing revelation of how life adapts to a cruel environment.

From a headland about a thousand feet high on the Greenland coast near McGary Island we could see mile after mile of ice, a grinding, snarling mass of white blocks. They are broken, pushed and piled up against the rocky flanks of McGary.

This is ice that has, in Arctic summer, broken away from the great polar icecap and been borne by winds and currents down through the narrow channels between Ellesmere Island and Greenland. Together with ice formed in the channels and basins and icebergs that have calved from the Greenland glaciers, some of it eventually finds its way to the North Atlantic.

During the winter the bitter, sterile crust extends southward, locking much of Baffin Bay from shore to shore.

A transparent avalanche of wind pours steadily across McGary—unobstructed, bitterly cold, and silent, for the mighty winds of this place have nothing to whistle through. Few sounds accent the general silence; the low ominous grinding of the ice, an occasional loud report when a great floe splits, and the raucous call of eider ducks.

I found foxtail grass (*Alopecurus alpinus*), chickweed (*Cerastium alpinum*), and a species of saxifrage (*Saxifraga cernua*) in this desolate spot (page 532).

To these three species we can pay tribute as being among the hardest seed-bearing plants in the world. Doubtless such flowering plants could grow at the North Pole itself if there were anything there but naked ice and water.

The fact that plants such as grow on McGary Island can complete their cycles in about six weeks and then survive through the long dark polar winter, when the sun is below the horizon and the temperatures are in the deep subzeros, is a testimonial to the almost indestructible vitality of the living plant cell and the potency of sunlight. These are the irresistible forces of the living Ice Age.

### Peary's Son Visits Admiral MacMillan Aboard the *Bowdoin*

MacMillan made his first trip to the Arctic in 1908 as an assistant to explorer Robert E. Peary. A frozen foot kept him from completing the trek (April 6, 1909) that resulted in Peary's thrilling message, "Stars and Stripes nailed to the Pole."

In the 49 years since his first visit to the Arctic, "Captain Mac" has made some 30 expeditions north, each time bringing back valuable knowledge. From 1913 to 1917 he gathered scientific data in the Eskimo colony at Etah.

Here, sailing off Thule, the master of the *Bowdoin* points out a landmark to Robert E. Peary, Jr.

Young Peary was at Thule with a construction firm, helping United States Army engineers to build an air defense base.

U. S. Army, Official



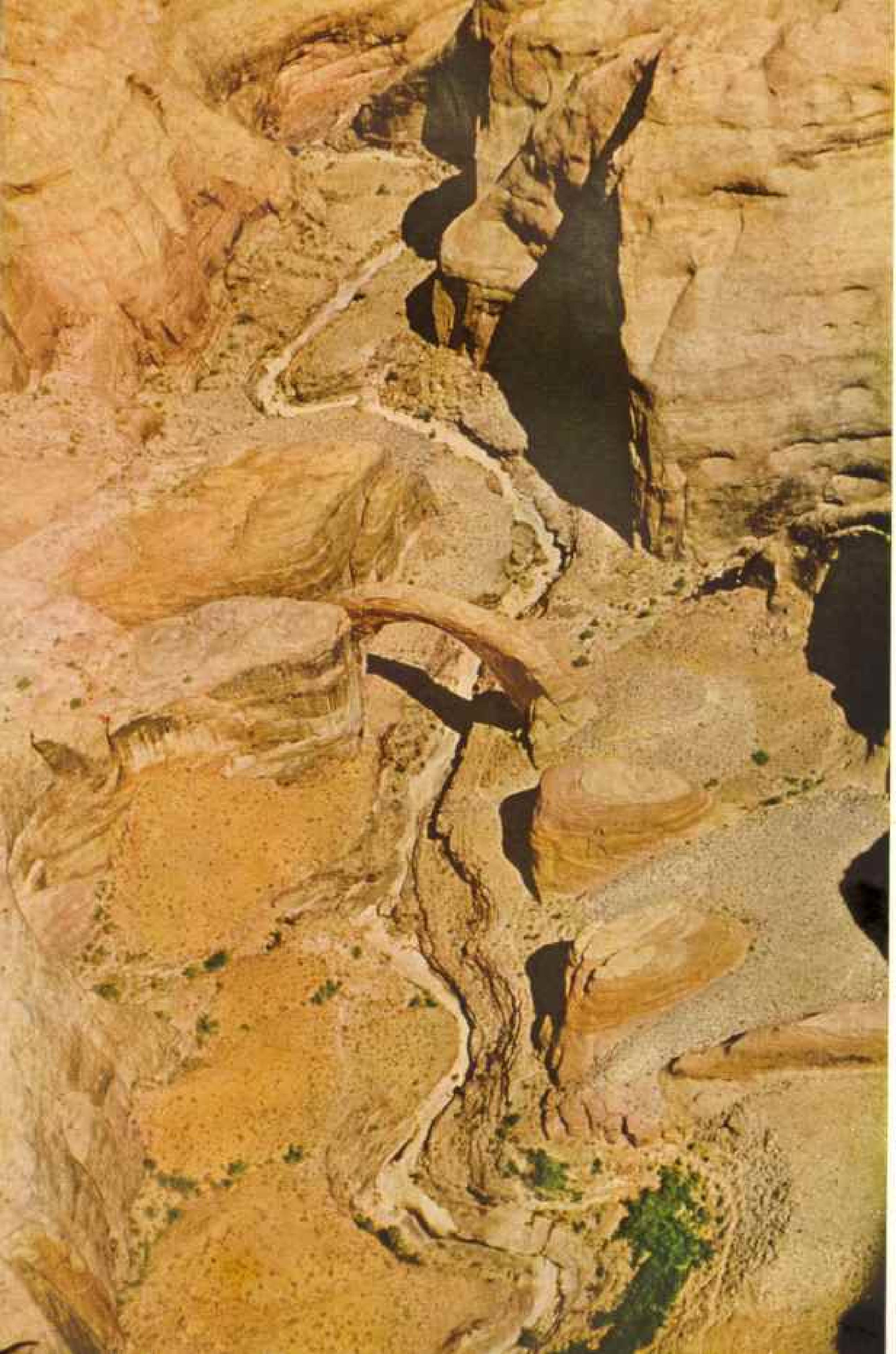

Few Visit This Hard-to-Reach National Monument in Southern Utah, but Those Who Do Never Forget Its Soaring Arch of Stone

BY RALPH GRAY

National Geographic Magazine Staff

*With Illustrations from Photographs by the Author*

THERE still are empty spaces in the United States. Along the Utah-Arizona border a desolation of stone and sand rolls on and on—a nightmare jumble almost unmarked by signs of man.

In the midst of this red-and-yellow wilderness of slickrock, at the heart of a vast roadless area, rises Rainbow Bridge, one of the natural wonders of the world. World travelers number it high among the sublime sights of creation (opposite and page 556).

Yet so remote and inaccessible has Rainbow Bridge remained since its recorded discovery by white men that in almost half a century fewer people have seen it than view Grand Canyon in two average summer days.

Talking with Neil M. Judd, leader of many National Geographic Society expeditions in the Southwest and a youthful member of the party that discovered Rainbow Bridge in 1909, I became inspired to see for myself this hidden gem of Uncle Sam's jewel case.

Page 546

## ◀ Rainbow Bridge Spans the Dusty Creek That Carved It out of Desert

So lost is this stone arch in the immensity of Utah's red rock and yellow sand that white men did not discover it until August 14, 1909. Within months the NATIONAL GEOGRAPHIC MAGAZINE published the first definitive account and pictures: "The Great Stone Arches of Utah," February, 1910, by Byron Cummings, one of the discoverers. Additional articles followed in October, 1911, and February, 1923. The September, 1923, Magazine presented Rainbow's first picture in color.

With popular interest aroused, President William Howard Taft on May 30, 1910, preserved Rainbow Bridge for all time by proclaiming it a national monument.

Almost as long as a football field, the bridge is wide enough for a two-lane highway. Among the world's natural bridges and arches, it stands first in size. Few can match the perfection of its lines.

Ages ago, while digging its channel, Bridge Creek cut into necks of sandstone. The stream wore away other formations, but this one it penetrated, leaving a great rib of rock suspended in air.

The author's party reached this remote formation in three ways: here by air; by river, and by horseback.

© National Geographic Society

Reproduced by Edwards Park, National Geographic Staff

Though no highway reaches within miles of it, I found, surprisingly, that there are three "roads" to Rainbow. With Edwards (Ted) Park of the National Geographic Staff, I tried them all. We traveled first by boat up the Colorado River, then overland on horseback, and finally by plane. In each case half the joy of seeing Rainbow was getting there.

We wanted to take the river road first. Maps told us the deeply entrenched Colorado surges within six miles of the bridge. But would the river be high enough for navigation? Where could we find a boat?

## Cowboy Turns River Guide

"Look up Art Greene at Marble Canyon," a friend in Gallup, New Mexico, told us. "He has a place perched on the rim and keeps a boat at Lees Ferry."

Marble Canyon lay 300 miles away, but our friend gave directions as though it were a ditch at the edge of town. He knew Art Greene as well as if he lived in the next block.

"Art will take good care of you," he said. "No one knows the river better. And when you're on the Colorado, having an expert along might save your insurance company a lot of money."

"Funny thing about Art," another said in the best tradition of Western exaggeration and humorous insult. "He was a poor but honest cowboy for years before he turned to river piracy. Now he owns that big setup he calls Cliff Dwellers Lodge, hobnobs with the governor, and doesn't blink an eye when people call him the Baron of Northern Arizona."

By the time our drive to Cliff Dwellers Lodge ended we felt we knew Art well, but no words could have prepared us completely for a meeting with this rimrock patriarch.

Though it was long after dark, Art glared at us with a high-noon squint that countless desert days had creased into his face. His battered Stetson, faded shirt, and tight jeans seemed as much a part of him as his craggy countenance, a near match to the Vermilion Cliffs rising 3,000 feet behind his place.







## One Road to Rainbow Is the Colorado River

Art Greene's powerful boat invades the highwayless desert, passing giant promontories and fantastic formations at every turn. After 68 miles the voyagers reached Forbidden Canyon; thence a six-mile hike led to Rainbow Bridge.

✦ Page 548, lower: These vacationing Los Angeles families exchanged food and news with the author's party. Driving rubber rafts, they floated down the rapids-free stretch between Hite, Utah, and Lees Ferry, Arizona.

## ✦ Swirling Waters Flash Past Templated Cliffs

This stretch of river remains as unmarked by man as when Maj. J. Wesley Powell first navigated the Colorado in 1869-72.

© National Geographic Society

549

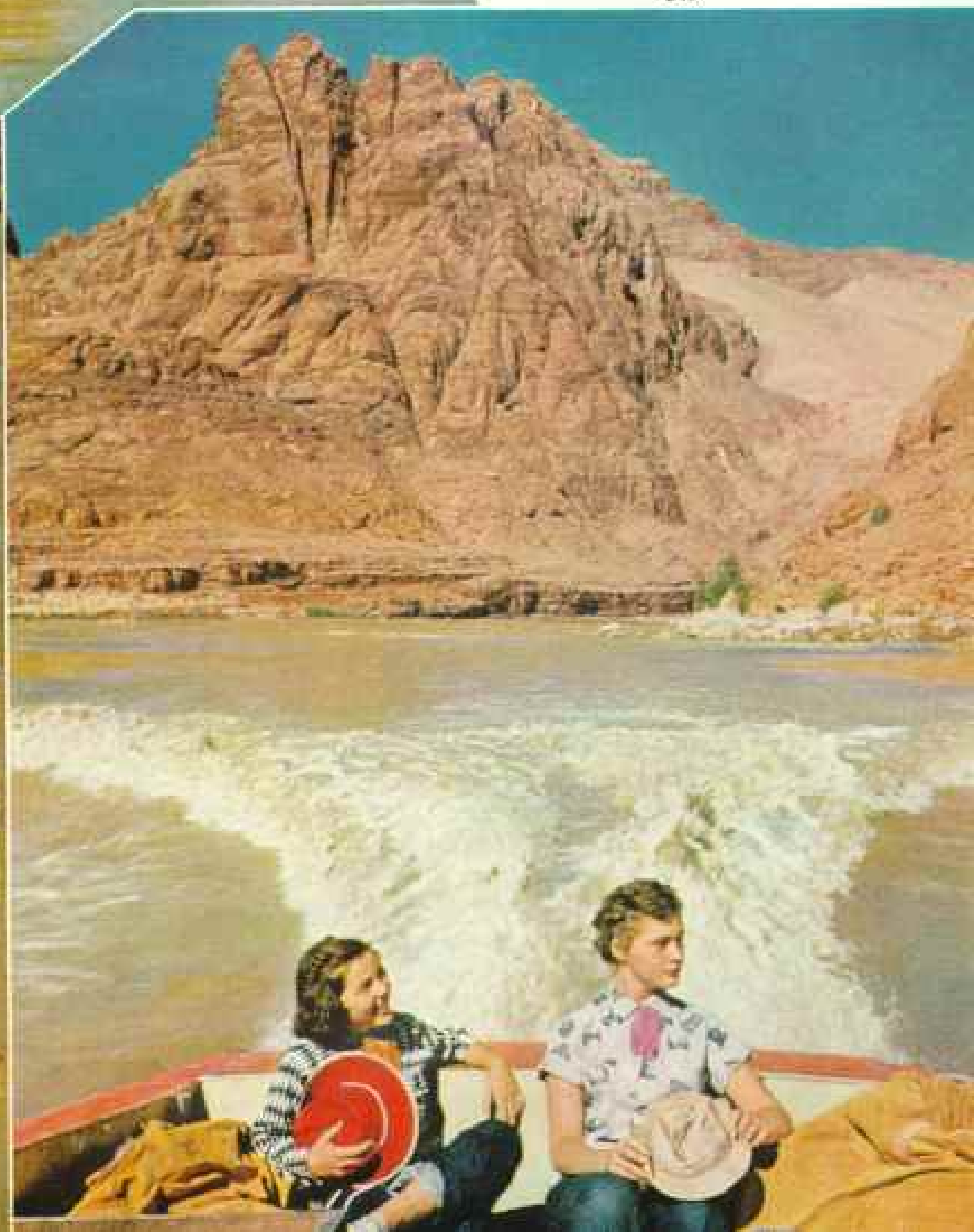

"I'm glad you're not one day later," he said in an unexpectedly soft and welcoming voice. "The river is dropping so fast the catfish are wearing straw hats. But we'll give her a good try."

Next morning Art's relatives began pouring out of the lodge's rooms, cabins, and trailers until Ted and I, the only guests, were almost lost in the crowd. Art picked out three grandchildren, one daughter, and one son-in-law to make the three-day trip with us.

We began by driving the few miles to Lees Ferry, leaving the highway at the west end of Navajo Bridge and following a side road that winds down the wall of Marble Canyon. This was the only spot in the 450 miles between Hite, Utah, and Lake Mead where a motorist could drive to the level of the Colorado River.

Lees Ferry is Mile Zero on the Nation's fourth-longest river. All upstream and downstream distances are measured from this point. The old Mormon ferry is gone, displaced by near-by Navajo Bridge, but a cable still spans the swift stream. It carries a man in a basket to the gauge on the opposite shore.

"Seventeen thousand cubic feet per second today," Art announced after speaking with the Government man. "That's about as low as I'd want to try it with my big boat."

It looked like worlds of water to me, but Art was serious for once. Earl Johnson, his son-in-law and helmsman, revved up the twin engines while the rest of us loaded the 24-foot craft (page 548).

#### "Trail to the Rock That Goes Over"

"What's that painted on the side?" I asked.

"I thought you story-writin' fellows could read," Art said, and then rattled off the Navajo words. "Tseh Na-ni-ah-go Atin"—that means 'the trail to the rock that goes over.'"

Art's daughter Irene and his grandchildren jumped aboard. Butch and Betty Jo Schoppman of Kanab, Utah, had traveled to Rainbow before, but it was the first trip for Judy Greene of Rough Rock, Arizona.

Earl, Irene's husband, sunburned as dark as a water-stained cliff, was Butch's idol. "This will be his fortieth trip," Butch said. "No one knows the river like Uncle Earl."

We shoved off—and promptly grounded on a submerged sand bar 15 feet from shore.

"That gives you an idea how shallow the old Colorado is," Art grinned sheepishly. Though heavy and big, *Tseh* draws only 16

inches of water. Her propellers are recessed in grooves along the hull bottom.

By alternately going ahead and reversing, much as you rock an auto stuck in the mud, Earl dislodged *Tseh*, gunned her into the main channel, and we were off.

Lees Ferry, with its desolate road end, cable, and one tiny house, soon disappeared around a bend. We seemed alone in the world as the vertical walls of Glen Canyon closed in, often rising directly from the river's edge. The sun beat down on our heads with a palpable weight. The air hitting our faces felt like the heated blast from a washroom hand drier.

All day long we churned upstream, averaging eight miles an hour despite an eight-mile-an-hour current. We were at the mercy of the river and the boat. None of us could have lasted long in the red-rock desert above, even assuming we could have found a way to scale the canyon wall. Pondering these things, we suddenly were given a near-tragic example of the perils of desert travel.

#### Plane Pancakes into the Colorado

A light plane glinted in the sun ahead, flying well within the close-set canyon walls. It appeared to be stunting.

"That's suicide!" exclaimed Ted, who had piloted fighters during the war. "Air currents in this winding gorge could slam it against a cliff or push it down to the water!"

As though bearing out his words, we saw the grim scene pictured opposite when we returned three days later.

Afterward we learned the full story. The flyer had been in trouble with a failing engine. What we took for stunting was his desperate effort to stay aloft.

Around the bend below us he pancaked in midstream and rode his drifting plane to shore, where it buried its heavy nose in the sand. He dragged pieces of driftwood together, made a raft, and floated down to Lees Ferry—"a very lucky man," as he told us later at Cliff Dwellers Lodge.

At the moment we knew nothing of this. *Tseh* droned on, Earl taking her from side to side in constant search for adequate depth.

Ted and I gaped at the passing scenery. Though the canyon walls rose 1,000 feet, an ever-changing panorama presented itself. "Desert stain," caused by water, had varnished each smooth cliff with a differing tapestry effect, like bunting on a Broadway parade route.

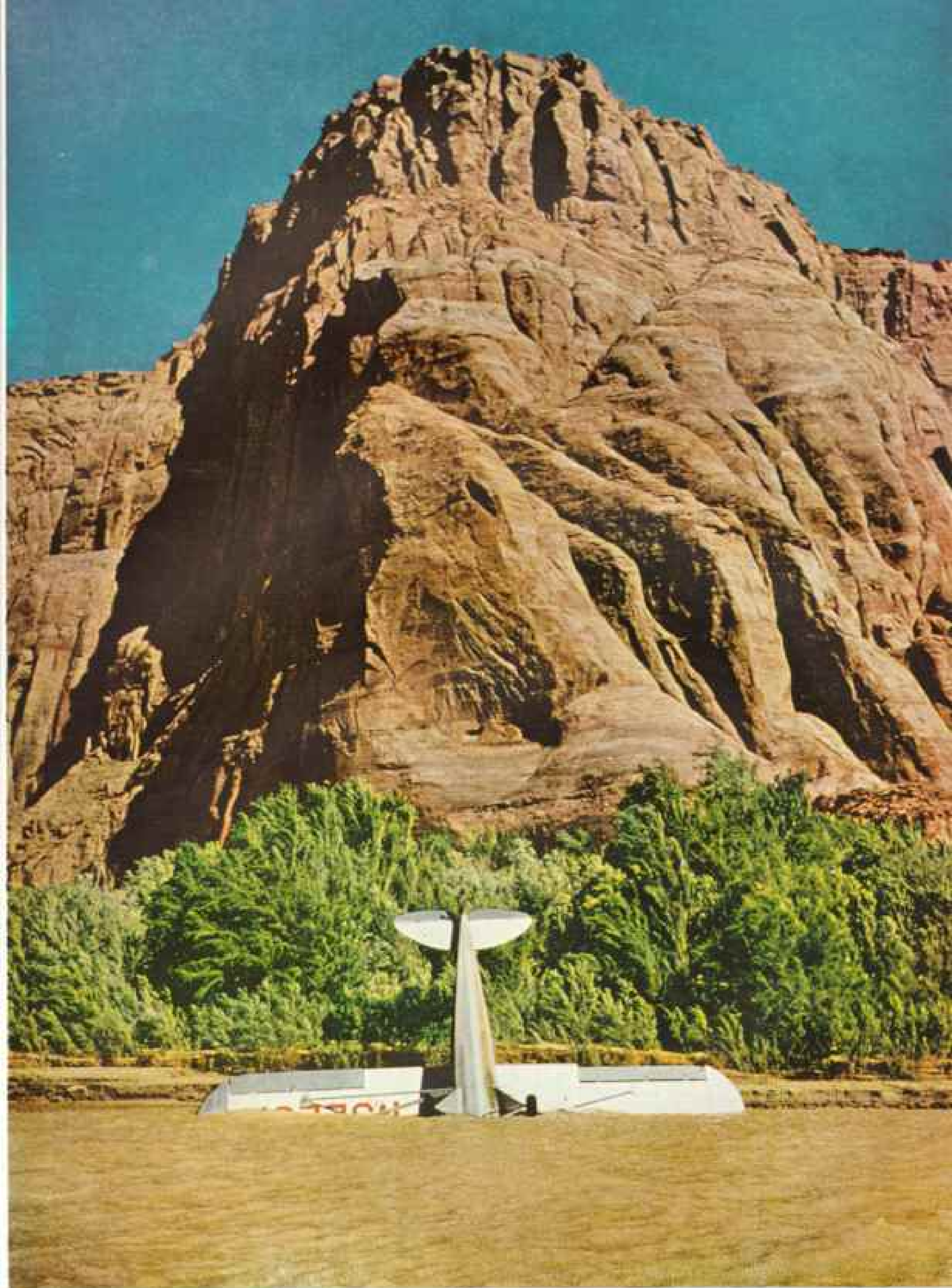

### Nose in Water, Tail in Air: a Monument to the Perils of Desert Flying

Swooping low, the pilot appeared to be stunting above the boat party. The rivermen, returning later, found the wreck. Engine trouble, they learned, stalled the plane; the flyer built a raft and drifted to safety.

In the Crossing of the Fathers region (Mile Forty), where the walls lower, a plaque marks the spot where Father Silvestre Vélez de Escalante found his way across the river on his epic exploration of 1776.

A few side canyons break the solid walls. We stopped for lunch in the slitlike mouth of one and walked along the tiny stream bed till it narrowed enough for us to reach out and touch both walls.

#### Uranium Hunters Drift By

On board again, we soon had company. Two life rafts floated toward us loaded with eight persons of assorted ages and both sexes. With their jumbled gear, large hats, and tanned backs they looked like a couple of suburbanite families on vacation—and so they were. We cut our motors and drifted with them awhile (page 548).

"'Geranium' hunters, eh?" Art said, noticing a Geiger counter.

"Yes, we're taking our time, doing a little uranium prospecting on the side," replied one of the two men.

"Stake any claims?"

"We got a pretty good buzz up in the

Shinarump a couple of days back and put down a marker."

Shinarump, I learned, was a stratum of likely uranium prospects. In this part of the Southwest, where there's a lot of geology (and not much else) on the surface, people locate places by the stratum they're in. Chinle, Wingate, Morrison are the desert's street names and highway numbers.

By now we were well into Utah. As the river twisted, we often looked ahead to bends where the Colorado seemed to end, to disappear into the rock just as it was believed to behave before Maj. J. Wesley Powell and his party first navigated the stream (page 549).

Finally I noticed Art peering ahead at a break in the wall: the mouth of Forbidden Canyon. Up this tributary gorge we would walk six miles tomorrow to Rainbow Bridge.

First we camped. As Earl turned off the thrumming motors, the susurrant Colorado kept our ears filled with sound and gave us pleasant music to eat and sleep by.

The children, freed of the close confines of the boat, rollicked and whooped around camp long after the rest of us had unrolled our sleeping bags and lay looking at the stars.

#### Map Traces the Author's Routes to Rainbow by River, Land, and Air

Valley areas in white will be flooded when Glen Canyon Dam, now under construction, pushes a man-made lake 186 miles up the Colorado and 71 miles up the San Juan. A dike will stop reservoir waters short of Rainbow Bridge. However, the backed-up Escalante River may wet the supports of La Gorce Arch, which honors the Vice-Chairman of The Society's Board of Trustees. Grosvenor Arch is named for the Chairman.

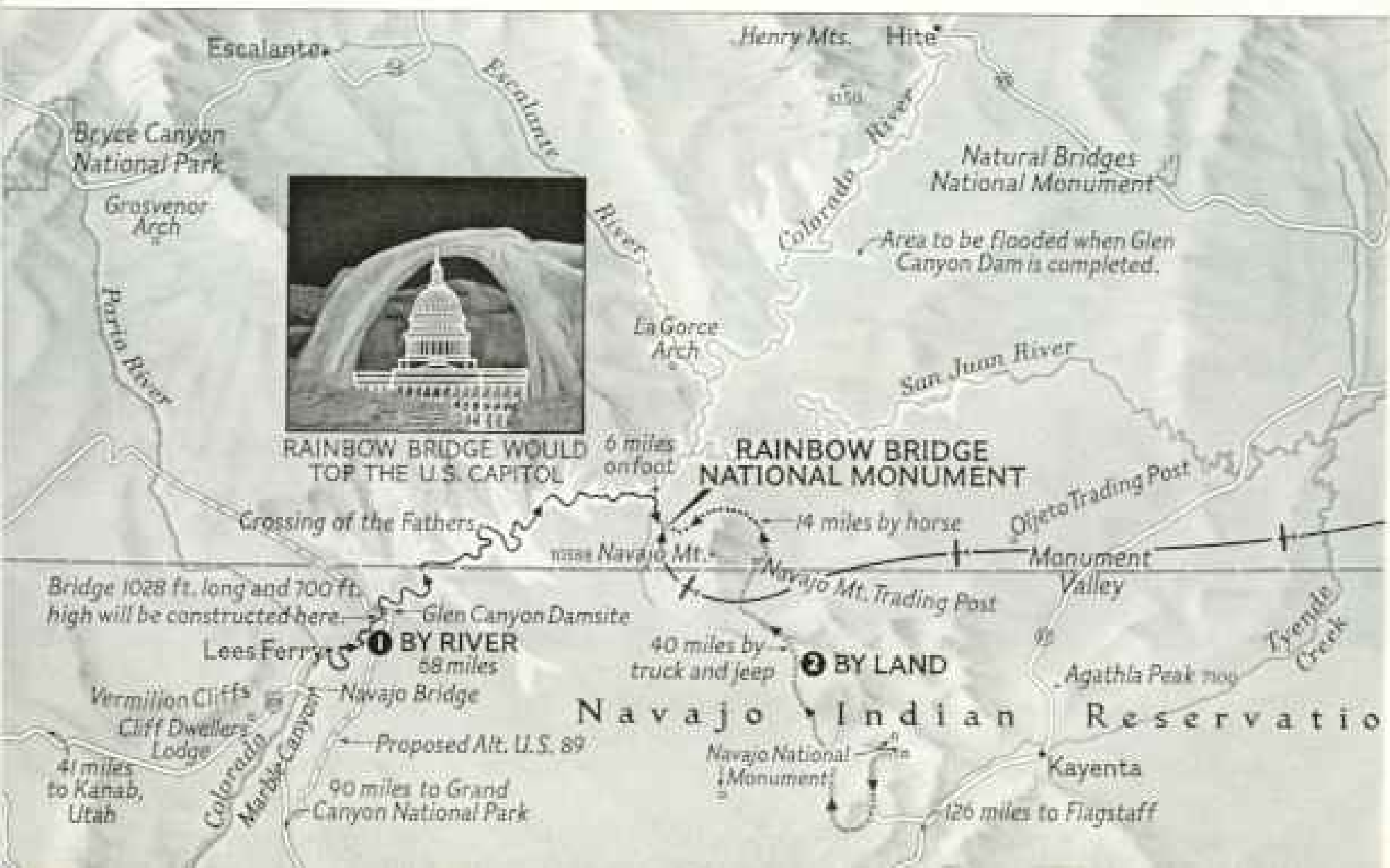



### † Forbidden Canyon's Water Tastes Sweet to Camera-laden Ralph Gray

Glen Canyon Dam's access roads and impounded waters will take sight-seers within a stone's throw of Rainbow. Its reservoir will fill Forbidden Canyon.

Next morning we started walking up Forbidden Canyon, a narrower version of the Colorado cleft. We crossed and recrossed the tiny stream that had carved this fissure and soon were in places where the sun never reaches. Maidenhair fern grows in ledges where water constantly drips from cracks. The pellucid stream courses from one bathtub-shaped pool to another, and the girls peeled down to their bathing suits for cooling dips.

Soon Rainbow Bridge Canyon came in from our left. We trudged along the bed of the dry stream that in ages past had been both architect and engineer on the Rainbow Bridge job.

Excitement mounted for Ted and me as we neared our objective. But a more immediate



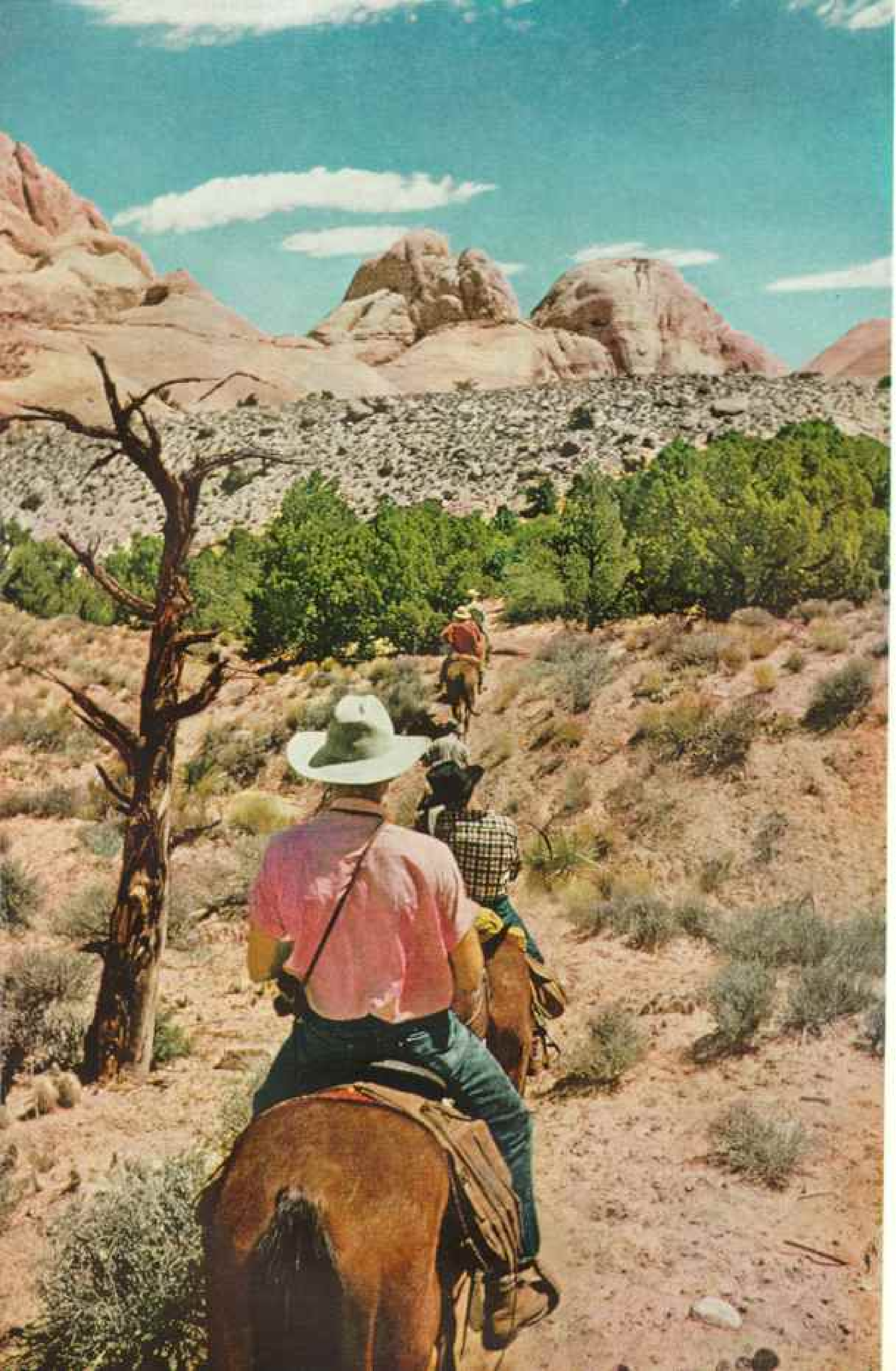

feeling was the pain of blistered feet. I walked the last mile on the heel of one foot and the toe of the other, shifting my photographic gear constantly to ease the weight.

Earl led us up over a shoulder of talus, paused at the top, and looked back to catch our expressions. For there ahead, partly hidden by an intervening cliff, an arch of stone gracefully jumped the canyon. Rainbow Bridge!

As we walked on and brought the stunning formation into full view, the feeling kept coming back to me that here was lifeless matter caught in dramatic action. Each time I looked, I felt that movement had just stopped, that if I had glanced up just one second sooner I would have seen the live stone leaping across the canyon.

#### Spring Plays Luncheon Music

Walking slowly to a point directly under the bridge, I stood in its shadow. Here the "flying-buttress" look is even stronger: the stone seems to stream from above and to arch gently down, cloistering the area beneath. The blocked-out sun sent oblique rays angling to either side and gave the span an indirect-lighting effect that set a mood of sanctity.

Inspired, I even heard chimes. Tracing the melodious tinkling sound, I found it came from a most unhallowed source. Previous visitors had left jars and containers of various sizes under the multiple drips of a seeping spring. Water dropped as from a dozen leaky faucets, each receptacle giving off a slightly different note.

Already Butch and the girls were unwrapping sandwiches under the weeping ledge. As we ate lunch, we needed only to lean over and take one of the brimful jars to quench our thirst. Otherwise there was little water near by, trapped in a few rapidly evaporating pools (page 559).

As a national monument, Rainbow Bridge is protected by the National Park Service,

and it is surrounded by thousands of square miles of the Navajo Indian Reservation.

From the earliest days a registry book for visitors has been kept under the bridge. Ted Park and I became signers numbers 10,740 and 10,741 (page 561). Signers have included Theodore Roosevelt and Zane Grey.

The ample pages of the register have room for reactions of awe, relief, frivolity. Many visitors wanted a "first" beside their names. One wrote "first girl to sleep all night on bridge." Farther along an unambitious man scribbled, "first man to die *under* the bridge." In the "Method of Transportation" column he wrote "hands and knees."

Nature has fashioned hundreds of bridges and arches in Utah and Arizona; new ones come to light almost every year.\* Yet Rainbow overshadows them all. Its span measures 278 feet, and it rises 309 feet—large enough, lacking 24 inches in width, to frame the United States Capitol (map, page 552).

But measurements mean little. Rainbow appears to change size dramatically, depending on the vantage point. Seen from below, it is enormous. Yet from the cliff above, it is dwarfed by its surroundings, so lost and inconspicuous I could understand why it waited so long for discovery.

#### Indian Led First Whites to Rainbow

The late Dr. Byron Cummings of the University of Utah, while on a field trip in 1908, heard rumors of a great stone arch somewhere near Navajo Mountain. Mr. and Mrs. John Wetherill, of Oljeto Trading Post, Utah, told him that Indians whispered of the wonder, but they knew no one who had actually seen it. When Mrs. Wetherill learned that Nasjah Begay, a Paiute, had been there and could guide a party back, Dr. Cummings laid plans to search for the bridge.

Meantime W. B. Douglass, a Government surveyor, was also looking for *Nonnezoshi* (popularly translated "hole in the rock"). The two parties joined and trekked for days across canyons, over slickrock, past ghostly whalebacks and baldheads, and through scrub juniper flats.

The trail-weary horses and men entered a final canyon and reached a sun-blistered, waterless spot. Nasjah Begay indicated that the bridge lay around the next bend.

Art Greene had described to me the next

\* See "Escalante: Utah's River of Arches," by W. Robert Moore, NATIONAL GEOGRAPHIC MAGAZINE, September, 1955.

#### ← Riders to Rainbow Follow a Mile-high Trail Through Pastel Desert

A Paiute Indian guided the Wetherill-Cummings-Douglass party in 1909 to Nonnezoshi (Hole in the Rock), which became known as Rainbow Bridge.

Here the National Geographic group follows a 14-mile trail that approximates the discoverers' route.

Sun-blistered, wind-blasted scenery is relieved by clumps of scented junipers. Occasionally a hidden canyon offers men and horses a cool drink.



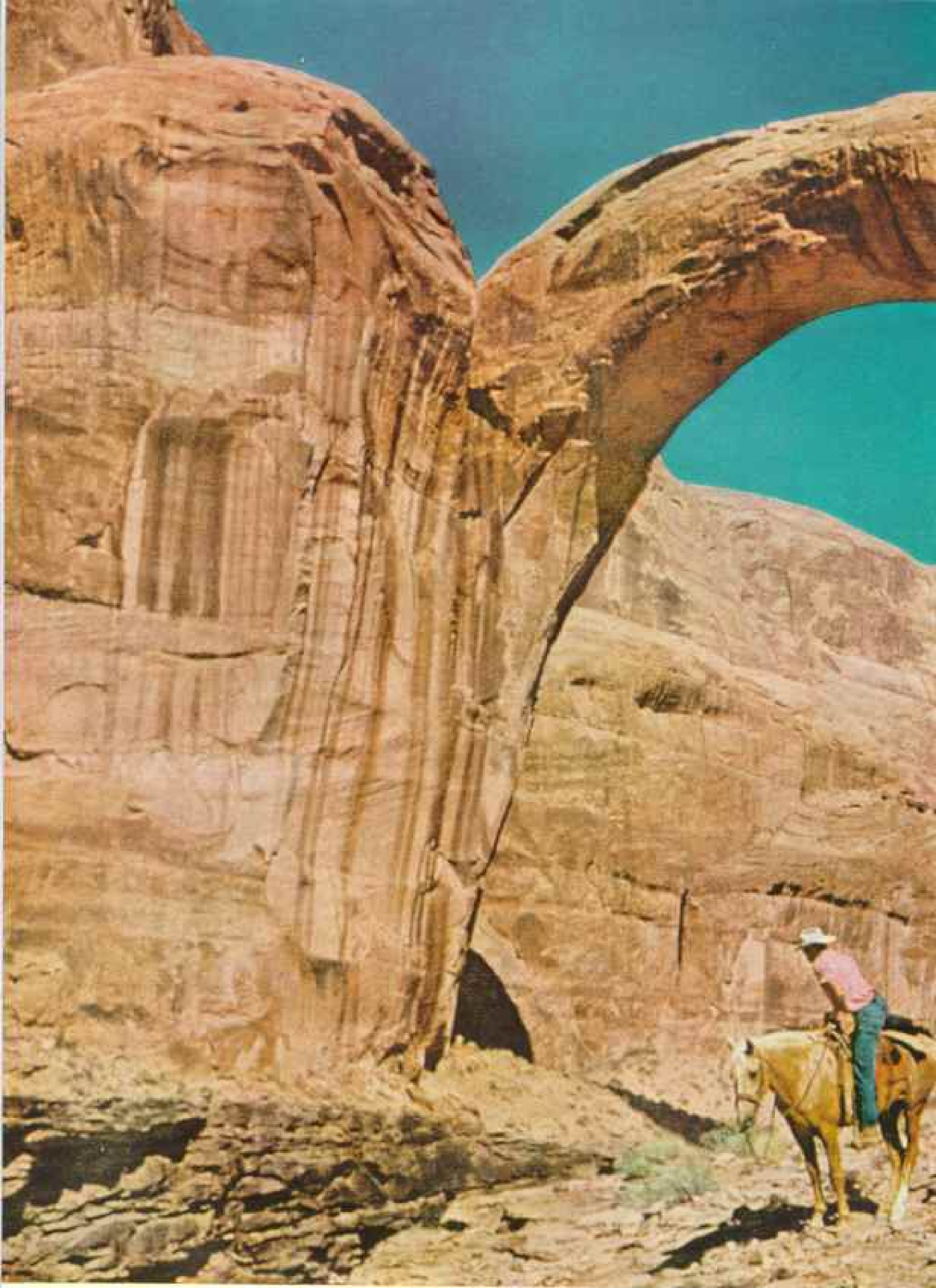

Thousands of Tons of Sandstone Defy Gravity and Soar Unaided Across the Sky. Rainbow rises structurally perfect, delicately slender, yet massively braced for the millenniums,

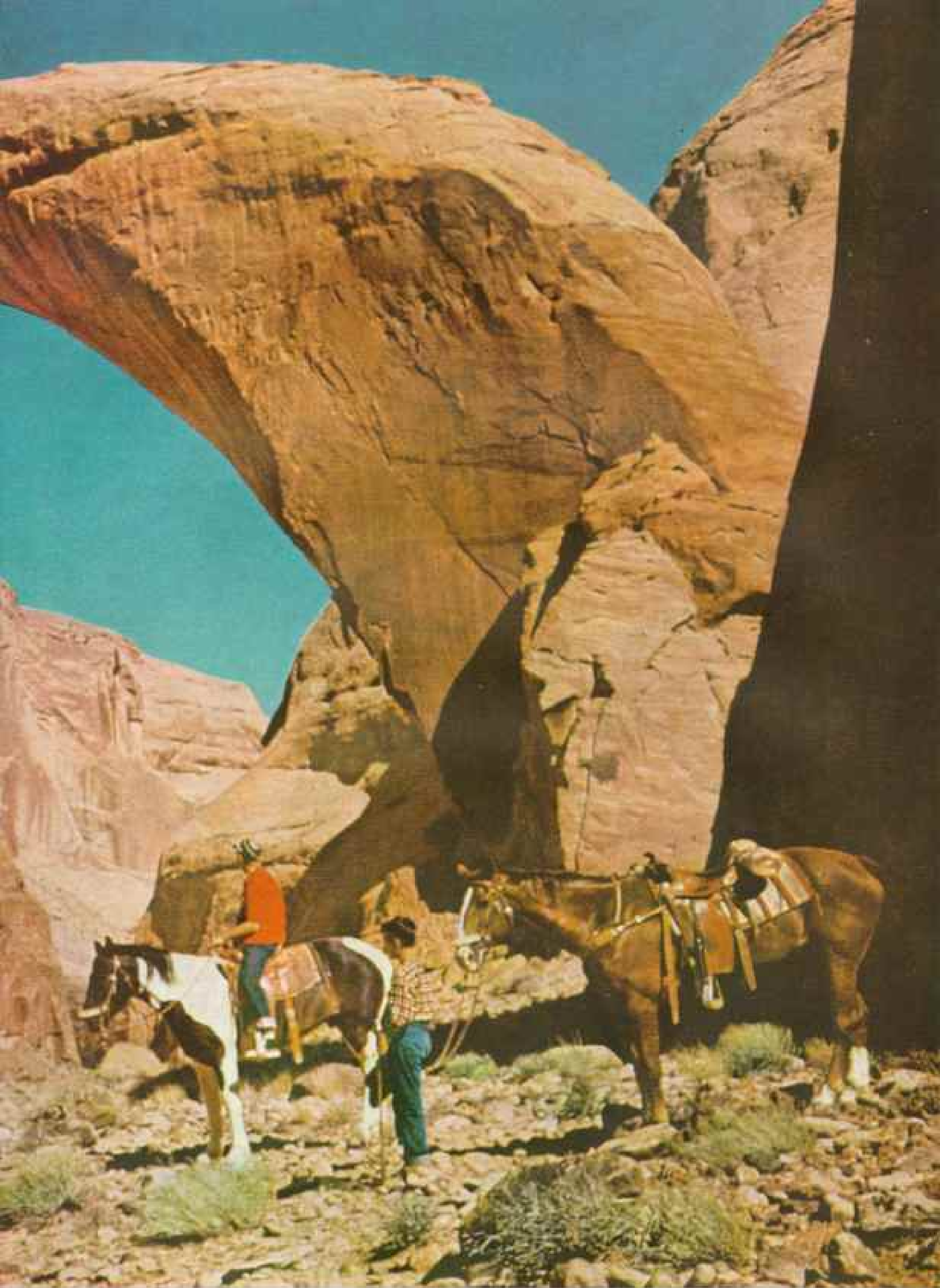

Utah's Natural Bridge Carries No Traffic and Leads Nowhere. It Spans a Void  
Visitors are rare. More people see Grand Canyon in a day than reach Rainbow in a quarter of a century.

few moments of August 14, 1909: "Naturally there was rivalry among the men as to who would be first to see Rainbow. Wetherill agreed to hang back and allow Cummings to glimpse the bridge first. Then they stopped and let Wetherill be the first to walk under it." Other reports indicate that Douglass was the first to reach the objective.

To this thirsty and hungry trio went the honor of telling the world about Rainbow. Theirs was the vision that turned rumor into reality and resulted the following year in preserving their find as a national monument.

Soon Rainbow Bridge will lose some of its age-old isolation. Glen Canyon Dam, now under construction by the Bureau of Reclamation, will back water from the Colorado into Forbidden Canyon. A new highway running

north from U. S. 89 will lead to the dam. Thus motorists in the future will be able to drive to a boat landing and skim over the man-made lake to within shouting distance of Rainbow.

Our feet would have been thankful for a ride down Forbidden Canyon by motorboat. When we straggled into camp, Ted and I propped our throbbing extremities in the air and let Art Greene feed us the delectable fine-meated catfish he had caught in the river.

"It's not your feet that will be sore next time you go to Rainbow," Art joshed us.

He was right. Our second "road to Rainbow" was the horse trail from Ralph and Madeleine Cameron's Navajo Mountain Trading Post (page 554). We rode 28 rough miles and, while our feet were healing, the blisters appeared at other places.

The trail measures 14 miles—a good day's work. Before saddling up we had driven to remote Navajo National Monument to meet Foy Young, a tall and soft-spoken Westerner, typical of the personable and dedicated men who administer our National Park Service areas. Foy doubled as superintendent of both Navajo and Rainbow. Because so few persons visit the latter, he ordinarily stayed at his Navajo headquarters, making only occasional trips to the bridge.

"I'm starting tomorrow for my midsummer inspection," said Foy. "Why don't you and Ted come along? Three other riders will join us later."

#### Sheep Trails Through Navajo Land

We piled into his pickup and took a short cut across the mile-high reservation, passing Navajo herdsmen with their dusty flocks and grinding our way through sand drifts blown across the slightly recessed desert track. Foy chose from myriad sheep trails the paths that led most directly to Navajo Mountain, 10,388 feet in elevation, the vast whale-backed landmark that can be seen from almost unbelievable distances in the clear air.

At a final Y, the right fork led to Navajo Mountain Trading Post. The post finally loomed before us, its buildings shaded by huge cottonwoods, a bit of green grass growing be-



#### To Get Up on the Bridge, One First Has to Scramble Down a Rope

Edwards Park, of the National Geographic Staff, works his way down a rock wall abutting the monument. This 40-foot descent will put him on the stone arch (opposite).



© National Geographic Society

559

#### ♣ Stone 42 Feet Thick Hangs in Mid-air

Author and companions unfurl the National Geographic Society flag. Their footing was tricky, a blustery wind was blowing, and the 33-foot-wide platform felt none too secure.

#### ♣ Watery Mirror Inverts the Arch

Bridge Creek, architect of the span, dries completely every summer. This shallow catchment in the creek bed did not linger long in the blistering sun. A cool spring near by always stays fresh.



hind a white picket fence. Indian ponies and a couple of the inevitable pickups were standing in front of the post store. Ralph Cameron, the trader, broke off a conversation in Navajo with one of his customers and welcomed us warmly.

Next morning the first hour of the trip was a five-mile ordeal by jeep to a rendezvous point where Bud Gilbert and other wranglers had brought up the horses. There is always great excitement at the beginning of any pack-trail ride, and this was no exception: getting acquainted with one's mount, deciding what to stow in the saddlebags, trying to act as if you did this sort of thing every day, but fooling nobody—especially not your horse.

But with a tug here and a nod there, Bud Gilbert quickly had his string on the trail. Whereas our river road to Rainbow took us through the bowels of the earth, here on horseback we were on top of the world, on the plateau at the 5,000- to 6,000-foot level.

#### High, Rocky Trail to Rainbow

All day our sweating mounts picked their way across the northern ridges and furrows of Navajo Mountain. Immediately to the north the rocky flats drop off toward the San Juan River, finding a way through this tortured, stove-hot, Dantesque landscape.\*

We saw water only three times, at the bottoms of great gulches down whose sides we switchbacked aboard our blowing horses. At the first one—Surprise Canyon—we found the surprise was trees. A later surprise was meeting a lone Paiute. His friendly hello rang out clearly, then he started speaking in "signs and wonders." (He made signs and we wondered what he meant.)

Ahead of us loomed so-called Hellgate, a narrow box canyon we climbed at its dead end. Then we were up on the slickrock level again, where our horses slid on the polished, almost glassy surface of wind-smoothed sandstone. Finally we struck Bridge Canyon and followed its welcome late-afternoon shadows to Echo Spring Camp.

Ted and I strolled the remaining half mile to Rainbow Bridge and saw it at one of its best moments—in the muted, faint-colored, cathedral light of dusk, with a rose-window sky above.

Though I had seen this natural wonder only a few days before, it burst upon my view with the same thrill of newness. I believe one is never quite convinced the giant span is real.

Here stone loses its stolid, earth-bound role. The blind processes of erosion have shown thousands of tons of rock how to defy gravity and soar unaided across the sky. The viewer stands spellbound, still hardly believing Rainbow is not a dream.

Back at camp, Bud was throwing together a meal when we returned. He keeps a supply of staples, canned goods, cooking utensils, and dishes under lock at Echo Camp. Later he pulled cots and blankets out of a shed, and we made our beds in the open air.

In the morning Ted and I, with 16-year-old Mickey Haskell of Newport Beach, California, hooked canteens on our belts, grabbed a 40-foot coil of rope, and started out to climb Rainbow Bridge, something few of the monument's visitors attempt.

We walked under the arch and down the canyon about 400 yards. There we started climbing the west wall (page 556) at a point where it is broken and slopes gently up to a great shoulder almost level with the top of the bridge. As we climbed, we clung to numerous natural toe holds. Doubling back, we crossed a narrow neck onto the abutment at the west leg of the bridge.

I had thought the bridge and this abutment joined together, but there is a crack between them about a foot wide. Someone had driven a spike securely into the top of the abutment; we looped the end of our rope around it and lowered ourselves hand over hand (page 558). Forty feet below, our dangling feet struck the bridge at a point near enough to the top to give fairly level footing.

#### Final Assault by Air

Slender as Rainbow looks in certain views, it measures a solid 33 feet wide and 42 feet deep at the top. Leveled and smoothed, it could accommodate an average highway. But for us, stepping over the ribbed and pocked surface and avoiding the sloping edges in a blustery wind, it seemed crowded with only three pedestrians (page 559).

The feeling of dizzy height from our perch in the sky prepared us for our final assault on Rainbow. After riding back to Navajo Mountain Trading Post, we drove to Cortez, Colorado, where Vic Reynolds strapped us into a Piper Tri-Pacer for a flight over our objective.

\* See "Desert River Through Navajo Land," by Alfred M. Bailey, NATIONAL GEOGRAPHIC MAGAZINE, August, 1947.



Author Gray Signs. His Name Is the 10,741st Entered in the Registry Since 1909

Though quickest and cheapest, the aerial road to Rainbow lacks the intimacy of the other two methods: you *see* the bridge, but don't actually *visit* it, since there is no place to land. However, the sight is so magnificent that I'm sure this method of reaching Rainbow will become more popular.

Our flight took us past Ute Peak, then straight west in a line a few miles north of the Arizona-Utah border.

Even from the air Navajo Mountain looms as the largest landmark of this two-State area. Vic headed directly for it, passed it on the south, and swung sharp to the right around its west shoulder. Almost immediately he pointed down with urgent gestures.

There, already in view below, was Rainbow Bridge. I remembered the long hot day we had spent riding horseback from this same mountain to the bridge—such a short distance when seen from above.

Dwarfed by our height, Rainbow looked like half a butterscotch Life Saver lodged in a crevice (page 546). Vic stayed at least 500 feet above the plateau, an altitude which put us about 1,500 feet from the canyon-buried

bridge itself. From this ultimate vantage point I got a glimmering of how this and other natural bridges are formed. Bridge Creek first laid down a stream course that meandered back and forth. Later uplift of the region caused the stream to furrow a canyon in the soft Navajo sandstone.

This canyon followed the previous meandering watercourse and created necks of solid rock where the stream bent back upon itself. Silt-laden water scoured this neck from both sides, finally piercing it.

The stream flowed through the short cut, widening it. Seasonal erosion further shaped the bridge, and centuries of wind gave it a final polishing.

There is a school that explains works of art in terms of algebra and trigonometry. Ted Park and I felt, as we flew away from the world's largest and most beautifully shaped natural bridge, that geology and erosion fall as far short in explaining Rainbow's creation. We twisted in our seats to keep the arch in view as long as possible, not knowing when—if ever—we would again see this transcendent wonder of the American Southwest.

# Rockets Explore the Air Above Us

Scientists, Firing Missiles Equipped with Electronic Eyes and Ears,  
Probe Mysteries on the Borders of Outer Space

BY NEWMAN BUMSTEAD

National Geographic Magazine Staff

**T**HIS is a story of scientists reaching up from the bottom of an ocean—the ocean of air that engulfs our planet hundreds of miles deep.

It is a story of screaming rockets with robot brains that sense surging currents in the upper atmosphere where someday man himself will freely venture. It is a story of experiments, months in preparation, that succeed or fail in minutes; and a story of determined men to whom failure means only a better chance for the next attempt.

## Rockets Prepare Way for Earth Satellite

Since the Wright brothers flew above the dunes near Kitty Hawk, man has lifted himself heavenward in ever-increasing leaps. He has fought two world wars in the skies and girdled his globe with airways. He has soared to a reported 126,000 feet. Impressive? Yes. But his highest ascent is a mere fraction of the distance to the air ocean's outer reaches.

Late this year or early in 1958, American scientists will toss a man-made satellite to the outer bounds of the atmosphere and beyond into space itself. This project will be part of the history-making International Geophysical Year between July, 1957, and December, 1958.\*

Recently I spent weeks with explorers who are probing and feeling their way upward through this sky frontier. Some worked from ships in the Pacific, some from the desert sands of New Mexico, and others from Hudson Bay's subarctic shores.

I began in August with the scientists of Operation San Diego High, 350 miles at sea off southern California. They named the expedition after the atmospheric high-pressure area that characterizes the region.

Theirs was an undertaking that would delight boys of any age who had ever touched off Fourth of July rockets or thrilled at the sight of escaped toy balloons racing skyward. Though their purpose was serious, balloons and rockets were their tools, and they had two ships and 650 men to help them.

Our ship, the U. S. S. *Colonial*, an LSD,

was not picked for her trim lines or for her steadiness. She was actually a seagoing dry dock with enough of a ship's characteristics to enable her to do 15½ knots. The destroyer U. S. S. *Perkins* patiently loafed along behind us.

The *Colonial's* stern could open like a farm wagon's tail gate, flooding a 392-foot by 41-foot well deck and turning it into a haven for small craft. Instead we used the ship's well to store three trailer-truckloads of helium. The broad deck above served admirably for balloon launchings.

On our second morning out we made ready for our first rocket launch. A hundred feet above the deck rose a giant inverted onion, a polyethylene plastic balloon, most of it draped in closely gathered folds reaching up from the ship like the onion's stem (page 565). Five thousand cubic feet of helium in the 20-foot bulge at the top would eventually swell to 30 times that volume in the thin air of the balloon's ceiling at 80,000 feet.

Terse commands to the helm and engine room kept the *Colonial* moving with the

\* See, in the NATIONAL GEOGRAPHIC MAGAZINE: "The International Geophysical Year," by Hugh I. Dryden, February, 1956; and "Space Satellites, Tools of Earth Research," by Heinz Haber, April, 1956.

## Rockoon Away! Plastic Balloon Soars → Aloft with a Rocket Riding Its Tail

In these Pacific waters last summer a 650-man expedition probed the secrets of the ionosphere, a layer containing ionized particles and electrons, 50 to 250 miles above earth.

Rockets and the balloons to lift them, together called Rockoons, were the scientists' tools. U. S. S. *Colonial*, a landing ship dock, served as the launching platform.

Here the first of the group's 10 Rockoons heads skyward. A 12-foot rocket dangles at the end of the 100-foot nylon line. At 80,000 feet the radio-controlled rocket will spout fire, pierce the balloon, and streak up another 50 or 60 miles. Sensitive electronic instruments in its head will measure light rays in the ionosphere and report back by radio.

Photograph was taken aboard the destroyer U. S. S. *Perkins*, which accompanied the expedition. A small weather balloon rides the breeze above the *Colonial's* bridge.

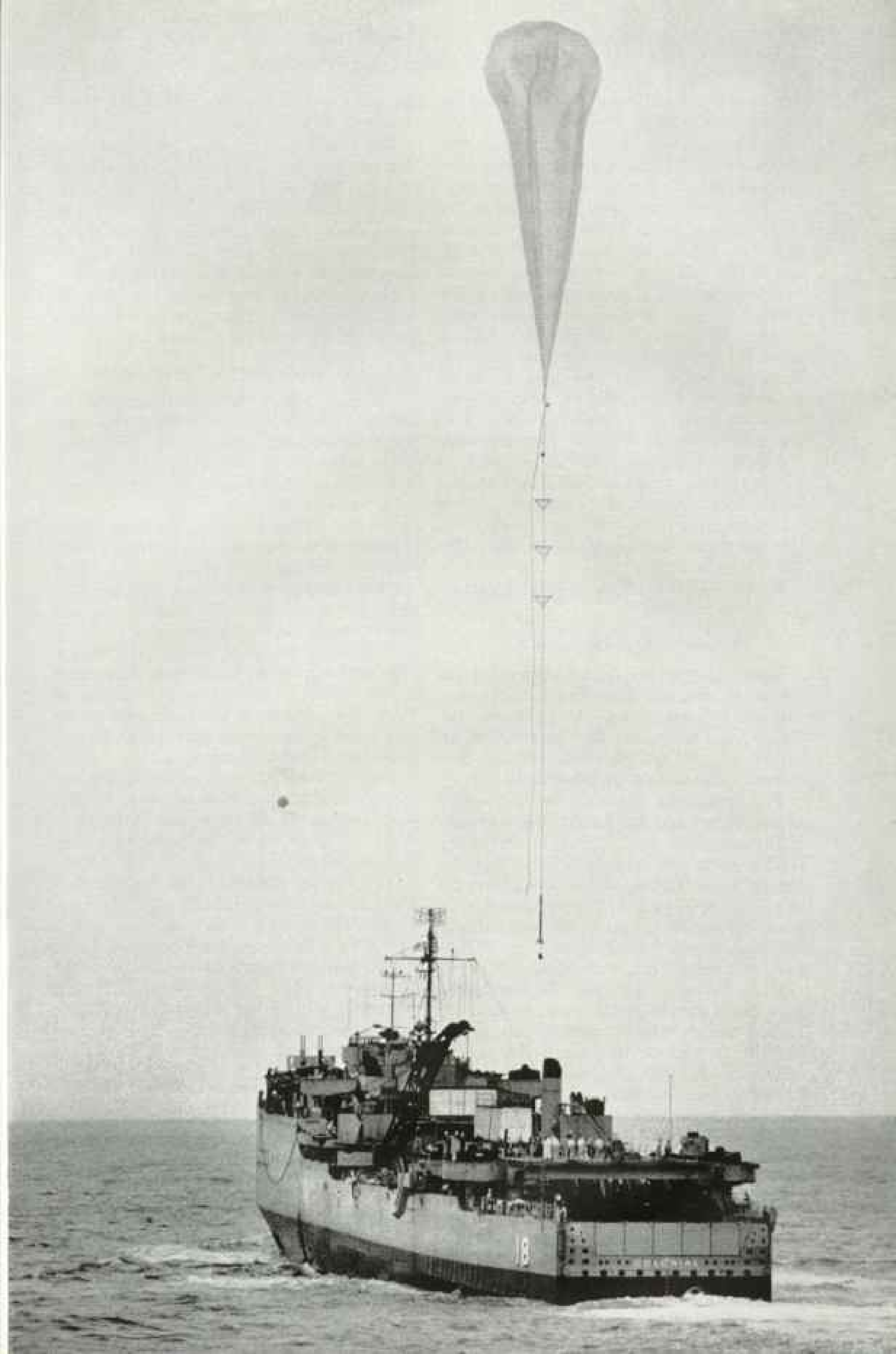



breeze—same speed, same direction—and the balloon stood steady, straight up.

On deck, men attached boxes of instruments and metalized nylon-mesh objects resembling minnow traps—targets to intercept our radar beams and send them back to the ship—to a 100-foot nylon line. Dangling from the balloon, the line looked like a gigantic kite tail. Its lower end was fastened to the payload, a 12-foot rocket resting like a length of pipe on a sawhorse (page 566).

When all was ready for launching, six men eased the rocket from the sawhorse and held it as the balloon rose and took up slack. Smoothly the balloon slipped away, pulling its rocket-tipped tail behind it. The first of the expedition's 10 Rockoons was launched.

Ninety minutes later the balloon and its pendent rocket would be 80,000 feet up and highballing westward at 30 knots. When conditions were right, the rocket would spout fire and streak another 50 or 60 miles into the atmosphere.

How would we start the rocket? By radio. Just touch a button.

#### Secrets of Our Ocean of Air

While the Rockoon floated skyward, I ate breakfast with the expedition's leader, Dr. Herbert Friedman, and his assistants, Dr. Talbot A. Chubb and Dr. James E. Kupperian, Jr. All are physicists of the Naval Research Laboratory in Washington, D. C.

Dr. Friedman's concern, and the object of our voyage into the Pacific, was a certain highly important part of sunlight that never reaches earth but is stopped by a layer in the air ocean known as the ionosphere, 50 miles up and beyond to 250 miles high. To probe the secrets of that region, our balloon-launched rockets were designed to carry skyward weird electronic sense organs.

I had learned a lot about the atmosphere from Dr. Friedman in the past few days. I learned about strange currents of atomic particles that course its upper levels at 200 miles an hour. Tides in this air ocean, with the same cycle as those in our seas, surge back and forth with the power of a million atomic bombs. I learned how it serves the earth as a storm window, absorbing rays of the sun that would kill or harm life on earth.

Of course, life as we know it would never have been possible without the atmosphere. To understand its value, imagine its being suddenly removed. Let's fancy that the

earth's atmosphere scudded off into space at 3 o'clock this afternoon.

We would not die gasping for air, like fish out of water. Instead, our blood would literally boil in our veins the instant the weight of the covering air—about 18 tons per person—ceased pressing from all sides. But let's assume that we could survive, somehow, to observe this strange world.

Gone with the atmosphere are blue sky and all signs of weather: clouds, mist, rain, snow. Even the wind is gone.

#### Sun Would Sear a Naked Earth

The sun pelts us with unprecedented intensity. This is the raw product that used to be filtered and processed by the atmosphere, tempered for all earthly life. Though it is daytime, stars blaze like white-hot coals in a jet-black sky.

As the afternoon wears on, there is no dimming of the sun, only a lengthening of its shadows—intense, stark shadows. No longer are there molecules of air to scatter the sun's light; all is contrast. We cook on one side and freeze in shadow on the other.

A crumb from space pierces your arm, a tiny meteor speeding many times faster than a rifle bullet. Larger meteors, millions of them daily, bombard the earth with explosive force. There is no atmosphere to turn them into harmless shooting stars.

Your arm hurts, and you try to cry out with pain. But you have no voice. Voice? That used to be air set in motion by vocal cords, waves of air to be heard when they beat on eardrums.

Now the sun approaches the horizon, glaring and undimmed though night is near. Finally the flaming disk disappears like a light bulb pulled down behind a board fence. No golden glow blends day into night. The atmosphere, which used to scatter blue light from the setting sun's rays, passing only penetrating red light, is gone. With it went twilight and dusk, evening's slow beauty...

#### Rockoon Mounts Toward the Great Void

Back on deck after breakfast I filled my lungs with salt air and felt a new appreciation of our life-protecting atmosphere. Hidden by cloud, our Rockoon slowly mounted skyward.

Fifty to 250 miles above us, higher than all weather, is the ionosphere, where the air is so thin that it can almost be likened

to earth without an atmosphere.

The ionosphere receives the sun's direct radiation. Our rocket would penetrate to that raw sunlight, to measure invisible ultraviolet light and X rays.

The ions that give the ionosphere its name are electrically charged atoms and molecules from which electrons have been stripped by X rays and by a particular part of the ultraviolet light known as Lyman alpha radiation (named for Prof. Theodore Lyman of Harvard University, who discovered it). With a quiet, normal sun, Lyman alpha penetrates much deeper into the atmosphere than X rays.

The rocket would measure X rays and Lyman alpha radiation. Its observations would add to our understanding of the origin of the free electrons that serve as tiny radio stations in the ionosphere. Radio signals bounce back and forth between the ionosphere and the ground, skipping from one continent to another. X rays and ultraviolet rays produce these radio-reflecting electrons at altitudes above 60 miles and are absorbed in the process.

### Why Radio Fades

During unusual solar activity the number of free electrons increases. But, surprisingly, at such times the ionosphere's reflectivity drops off instead of improving, and our world news roundup announcer may say, "I'm sorry, but our signal is not coming through from Cairo." This is called radio fade-out. Extreme cases are followed a day later by magnetic disturbances that cause compasses to waver over the entire earth.

Our rocket, now lazily riding the balloon's tail, was approaching 80,000 feet. In it were sensitive electronic instruments designed to detect Lyman alpha and X rays, and report what they learned back to our ship by radio.

Lashed to the deck stood a truck trailer that looked from the outside like those that haul peaches from

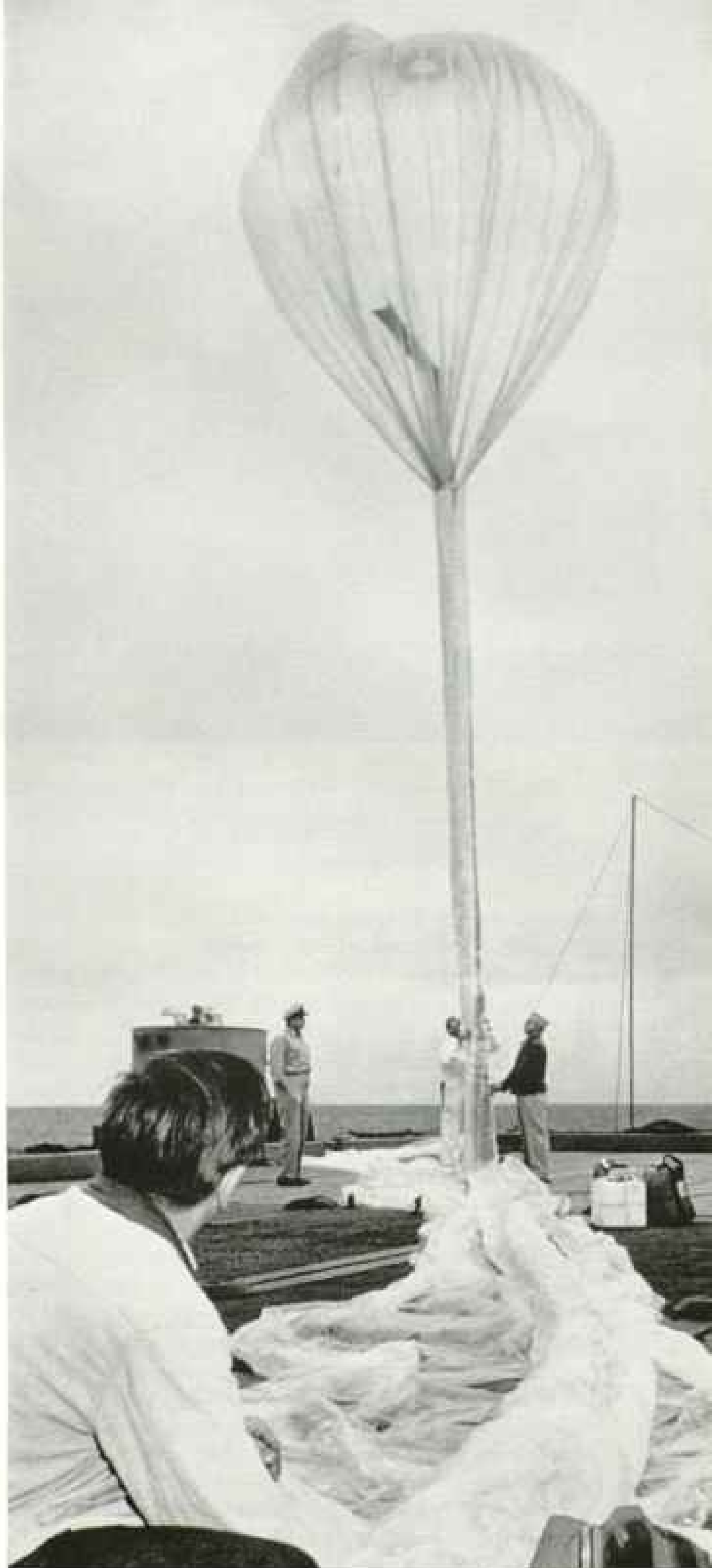

565

Robert F. Dixon

### Balloon Takes Shape as Tanks Below Deck Valve Helium into the Bag

Expanded, the bag holds 150,000 cubic feet of gas. In the rare air at 80,000 feet its diameter swells to 72 feet. Men here pull down an outer sleeve that keeps uninflated folds from billowing.



### Should the Rocket Fail to Fire, This Alarm Clock Will Drop It into the Ocean

Scientists aboard *Colonial* fired rockets by radio. If controls went awry, this safety device set off an explosive charge that sliced a line and dropped the rocket before it drifted into aircraft lanes. In intense cold aloft, the \$5 timepiece proved more reliable than precise mechanisms because its gears fitted less closely.

Georgia or shoes from Brockton. But not so inside. Dial-studded instruments rose tier on tier, the nerve cells of an electronic brain that would receive and record the rocket's findings. Switches snapped and needles quivered as the scientists tested and groomed the radio apparatus that would receive the rocket's messages from the ionosphere.

For some time now the *Perkins*, our destroyer, had been tracking the balloon like a hound after a rabbit. Though we lost sight of it in the overcast minutes after launching, the minnow traps on its tail blipped clearly on the *Perkins's* radarscopes and enabled her to keep headed in the right direction.

A seaman handed Dr. Friedman a radio message. He read it and passed it to me: "Balloon at 79,000 feet, range 39,500 yards, course 277°, speed 28 knots." Even with our full speed of 15½ knots the balloon was getting away from us, and the radio signal that would bring us the rocket's observations was not effective beyond 125 miles.

"We still have several hours before it gets out of range," said Dr. Friedman. "Let's hope we get a flare before then."

Flare? Yes. Dr. Friedman was talking about the sun's weather, and a flare may be likened to a flash of lightning on earth.

But what a flash! Beginning as bright areas the size of North America, flares spread in a few minutes over the sun's surface, covering hundreds of millions of square miles. Just as lightning on earth equalizes differences of potential between clouds, flares may be exchanges of tremendous energy in the sun's atmosphere between magnetic fields of varying strength.

### Radio Stands Watch for Flares

Some scientists have theorized that there must be an increase of Lyman alpha radiation during a flare. If Dr. Friedman could fire his rocket the instant a flare occurred, its instruments might prove the theory. This was his primary mission. If he succeeded, a vital fact would be added to man's understanding of the sun and its influence on the earth's atmosphere.

In the trailer laboratory four radios stood watch to alert us to the start of a flare. They constantly received broadcasts from Tokyo, Mexico City, San Francisco, and New Mexico. If all four signals faded at once, we would know a flare had begun. But by day's end none had occurred, so Dr. Friedman ordered the first of his 10 rockets fired.

We crowded into the trailer laboratory to

watch. The scientists manned switches and dials. Down went the count, "X minus three seconds . . . two . . . one . . . fire!"

In the thin, cold, silent air 80,000 feet above the Pacific the rocket streaked toward the high heavens. Up, up, up soared the trim missile, its instruments alert, sensing and reporting the state of the ionosphere. As the rocket approached an altitude of 73 miles, it slowed to a stop and then began its fall.

Meanwhile, back in the trailer, "Any Lyman alpha?"

"Yes, it's showing."

"How about X rays?"

"O. K."

"And aspect?" (The rocket's changing position relative to earth.)

"Coming in fine, but it shows the rocket is spinning fast."

Five and a half minutes later the needles on the dials suddenly stopped moving. The rocket had splashed into the ocean 100 miles away.

"Well, how did it go?" I asked Dr. Friedman. He advised patience; the lan-

### Last to Leave Deck Is the Balloon's Payload

Housed in the rocket's vacuum-tight head are 16 pounds of electronic equipment, including 29 tubes, 200 resistors, battery, and dynamotor. A four-channel radio transmitter beams signals concerning four different wave lengths of solar radiation.

Technicians here steady the rocket. Man at right cuts the tether. Dangling canvas bag contains the firing mechanism, which a radio signal from the ship will activate at 80,000 feet. The missile hangs at a seven-degree angle so as to miss the equipment below the balloon when it takes off.

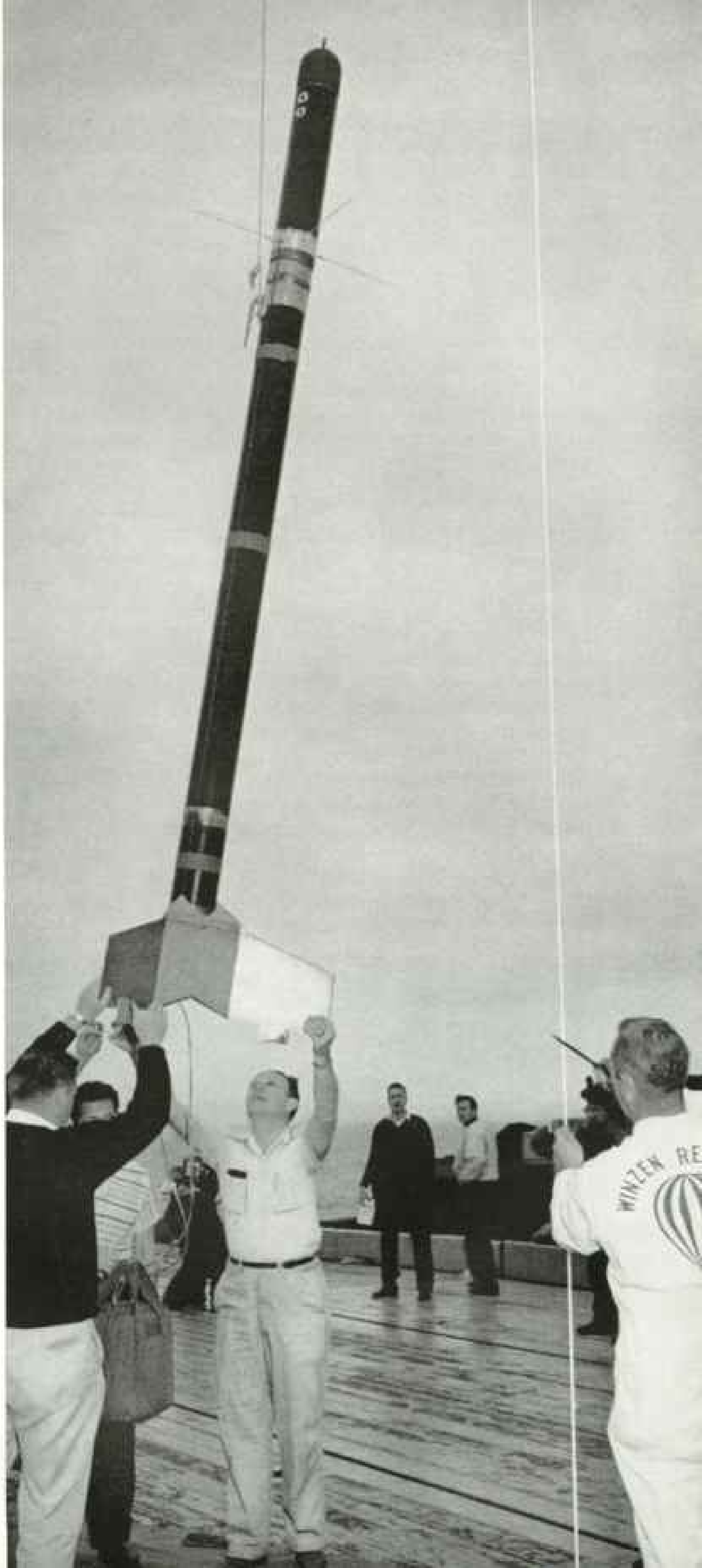

gauge of the speeding rocket had been taken down in "shorthand" by the trailer instruments on a roll of photographic paper.

When developed, the tape showed all instruments had functioned, and a normal condition existed in the ionosphere. Lyman alpha was higher than a year before when measured over New Mexico, but this was expected as the sunspot cycle neared its peak.

Dawn two days later saw another Rockoon slip into the sky. Noon came, and no flare. We went to lunch, leaving Robert A. Kreplin to watch the four radios and William A. Nichols to man the instruments should a flare occur.

### Expedition Scores a Triumph

At exactly 12:05, 1,400 miles away at the University of Colorado's High Altitude Observatory at Climax, Richard T. Hansen saw a flare begin. Satisfied within seconds that it was big enough to interest us, he radioed Sacramento Peak Observatory in New Mexico to relay the news to the *Colonial*.

But since Bob Kreplin's radio was operating on the same wave length as Hansen's, Kreplin heard him directly and fired the rocket. The trailer's electronic brain, "awakened" by Bill Nichols, sprang into action, and for the first time X rays and Lyman alpha

rays were being measured during a solar flare.

At this point, Dr. Friedman arrived on the scene. The instant his eyes swept the instruments he realized an important discovery had been made.

"As of this moment," he beamed, "the expedition is a success."

What had the dials revealed? What had he learned about radio fade-outs from the flare?

They showed that X rays—not Lyman alpha rays—are probably chiefly responsible for radio fade-out during a flare. Surprisingly, our rocket found no increase in Lyman alpha at all, but detected instead a sudden surge of X rays, strong enough to double normal ionization, penetrating to the very bottom of the ionosphere.

Previously, many scientists had believed that Lyman alpha were the only ionizing (that is, electron-removing) rays that penetrated this far down.

But this is not all. Measurements of flare X rays in the ionosphere may put us a step closer, albeit a tiny one, to solving one of the biggest mysteries of science, the origin of the immensely powerful cosmic rays that constantly bombard the earth from space.\*

\* See, in the NATIONAL GEOGRAPHIC MAGAZINE: "Trailing Cosmic Rays in Canada's North," by Martin A. Pomerantz, January, 1953; and "New Frontier in the Sky," by F. Barrows Colton, September, 1946.

### Radar Targets Resemble Minnow Traps. They Ride Balloons Far Above Man's Vision

Minutes after launching, Rockoons usually disappeared in the overcast. These metalized nylon devices intercepted radar signals from the *Perkins* and shot them back. Facing page shows their position in flight.

Robert F. Stone

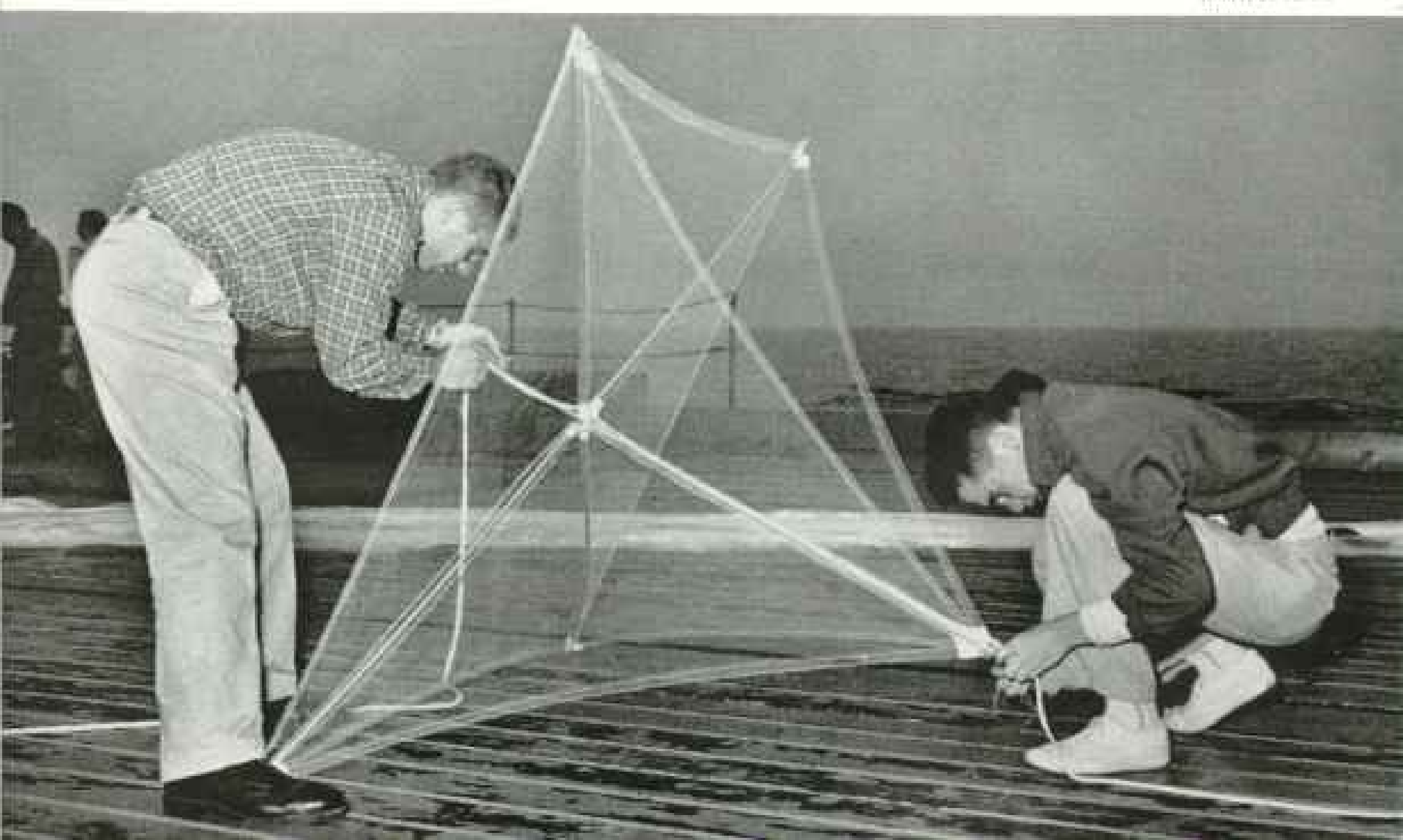

Do solar flares produce cosmic rays?

Infrequent detection of bursts of cosmic rays during large flares—five times in 15 years—might seem to indicate otherwise. But, as Dr. Friedman says, "Cosmic rays are like bullets, and our earth is a small target. They either hit us or they don't, but the X rays that accompany them spread in all directions."

Thus the occasional recording of great cosmic-ray surges when the sun flares, coupled with the fact that X rays always accompany our best efforts to produce cosmic radiation in laboratories, suggest that flares may be responsible for both.

#### Rockets May Find Powerful Rays

Dr. Friedman believes this to be true. He expects that his rockets will continue to find even stronger X rays as they continue to probe the secrets of flares during the forthcoming IGY.

Of course, it may be that billions of stars in our galaxy, of which the sun is but one, emit cosmic rays. Perhaps all space, the limitless universe, is crisscrossed by these mysterious particles.

The earth wears a shield of magnetic force as well as of air, and together these deflect or stop many of the weaker cosmic rays from entering the atmosphere. But near the poles of the earth's magnetic fields, where the lines of magnetic force dip steeply, even the weaker cosmic rays reach the lower air.

This explains why cosmic-ray scientists do much of their work in high latitudes. And it explains,

#### Rockoon Climbs into the Clouds

*Colonial's* scientists hoped to measure X rays and ultraviolet radiation in the ionosphere during a solar flare. They took the problem to sea because busy rocket ranges on land could not be tied up to await sun flares, which occur at unpredictable intervals. Balloon rockets launched from a ship off the California coast gathered the desired information. Just launched, this Rockoon drifts at 15 knots. Radar targets hang beneath the bag.

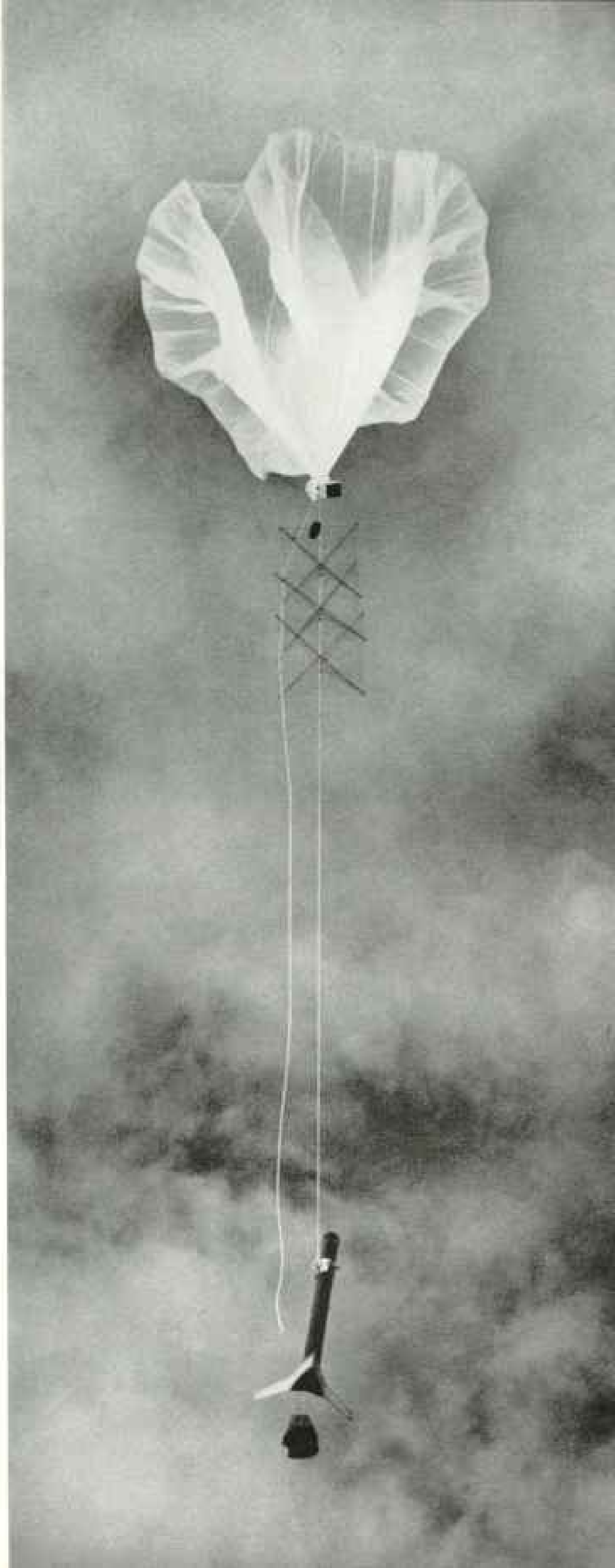



### Physicists Scan a Message from Space. A Flying Rocket Beamed This Graph

Telemetering, a method of radiating coded information, transmitted data from the ionosphere to the *Colonial* via circuits in the rocket's head. Variations in signal amplitudes—telemetering's language—show up as wiggles on this roll of photographic paper. Two of the wavering lines shed new light on behavior of X rays and Lyman alpha rays during a solar flare. Rocket head at right carries delicate electronic gear.

in part, why the United States Department of Defense at the invitation of our good Canadian neighbors built a multimillion-dollar rocket-launching site at Fort Churchill, Manitoba, on the western shore of Hudson Bay. Dedicated in October, 1956, the unique aluminum-covered structure suggests a 120-foot oilcan (page 575).

During the IGY this tower will belch 34 Aerobee rockets into the sky to measure the earth's and the ionosphere's magnetic fields; to record the temperature, pressure, and density of the high atmosphere; and to chart the speeds and directions of winds that churn the air 50 to 150 miles above the sub-arctic tundra.

Some rockets will whiz through northern lights, making measurements that may explain this eerie phenomenon.\*

To see the firing of the site's first trial rockets, I flew from Washington's balmy October Indian summer to zero temperatures at

Fort Churchill. Below, forests slowly thinned until only scrubby spruce trees bristled from the barren landscape.

I changed from business suit to GI arctic clothing and jeeped 11½ miles from airfield to launching site to witness the launching of Fort Churchill's first Aerobee rocket. There I met Nelson W. Spencer of the University of Michigan, directing the project for the Air Force's Geophysics Research Directorate.

Days of checking the rocket's instruments had passed; the 26-foot missile stood on its tail in the launching tower ready to go.

The rocket was scheduled to go off about midnight, not because of particular interest in night air data but because radio interference from missile ranges in the Bahama Islands and in New Mexico dogged the Fort

\* See, in the NATIONAL GEOGRAPHIC MAGAZINE: "Unlocking Secrets of the Northern Lights," by Carl W. Gortlein, November, 1947; and "Mystery of Auroras," May, 1939.

Churchill scientists during daylight hours. So did a cab dispatcher's voice from North Carolina: "Go to Fifth and Main." Both were fine examples of the ionosphere's ability to bounce radio waves great distances.

At X minus 45 minutes—about 11 p.m.—the site was cleared of all but those who would fire the rocket and attend instruments in the blockhouse. This small building, located only 200 feet from the launching tower, crouched under a heavy covering of earth. Temperature in the still, clear night outside hovered near zero.

A series of delays pushed X-hour back past midnight, past one o'clock, past two. One of our radar tracking crews, in a station four miles away, was having instrument trouble. Finally, at 2:20 a.m., the decision was made to launch the rocket without radar. Its course would still be traced, however, by Dovap (Doppler velocity and position).

Unlike radar, Dovap does not allow scientists to "see" the rocket on a screen. Instead, it sends up radio waves which are received and rebroadcast back to earth by the rocket. The returned waves combine with the original ground broadcast and produce a musical tone which varies with the rocket's speed—the faster the rocket goes, the higher the pitch.

Dovap's disadvantage is that its record cannot be read until computing machines have processed the data, usually weeks later. But it is accurate: Dovap can place a rocket's position 100 miles up within 50 feet.

Minutes dragged by. Then the count-down resumed.

"Coming up on X minus 20 minutes. Stand by...mark! X minus 20 minutes. Time is running."

Minute after minute passed slowly...finally

the last minute...the last seconds... "3, 2, 1, 0!"

At zero seconds the earth shook. The rocket thundered into the night. Fort Churchill's launching tower was christened (page 578).

#### Twenty-two Miles High in 43 Seconds

A low moan filled the blockhouse. This was Dovap's unearthly voice. Slowly its pitch rose, reaching a screaming high C at plus 43 seconds, when the rocket attained its highest speed. This occurred at an altitude of 22 miles, where fuel was exhausted. For the next 153 seconds the missile coasted to its peak of about 85 miles, the sound dropping in pitch. Finally, just before the highest altitude, the sound became inaudible because it fell below the 20-cycle-per-second lower limit of human hearing.

*(Continued on page 576)*

#### Shock Test Bounces a Rocket Head Against Steel Plate

Electronic instruments in the nose section receive an explosive jolt followed by a 70-G acceleration when a balloon-borne rocket is fired at 80,000 feet. Here Talbot A. Chubb (left), a member of the sea-borne expedition, and Herbert Friedman, the leader, simulate shock of firing by dropping the head 24 inches. This test detected weak electronic parts before launching.

*See also Donostail, National Geographic Staff*

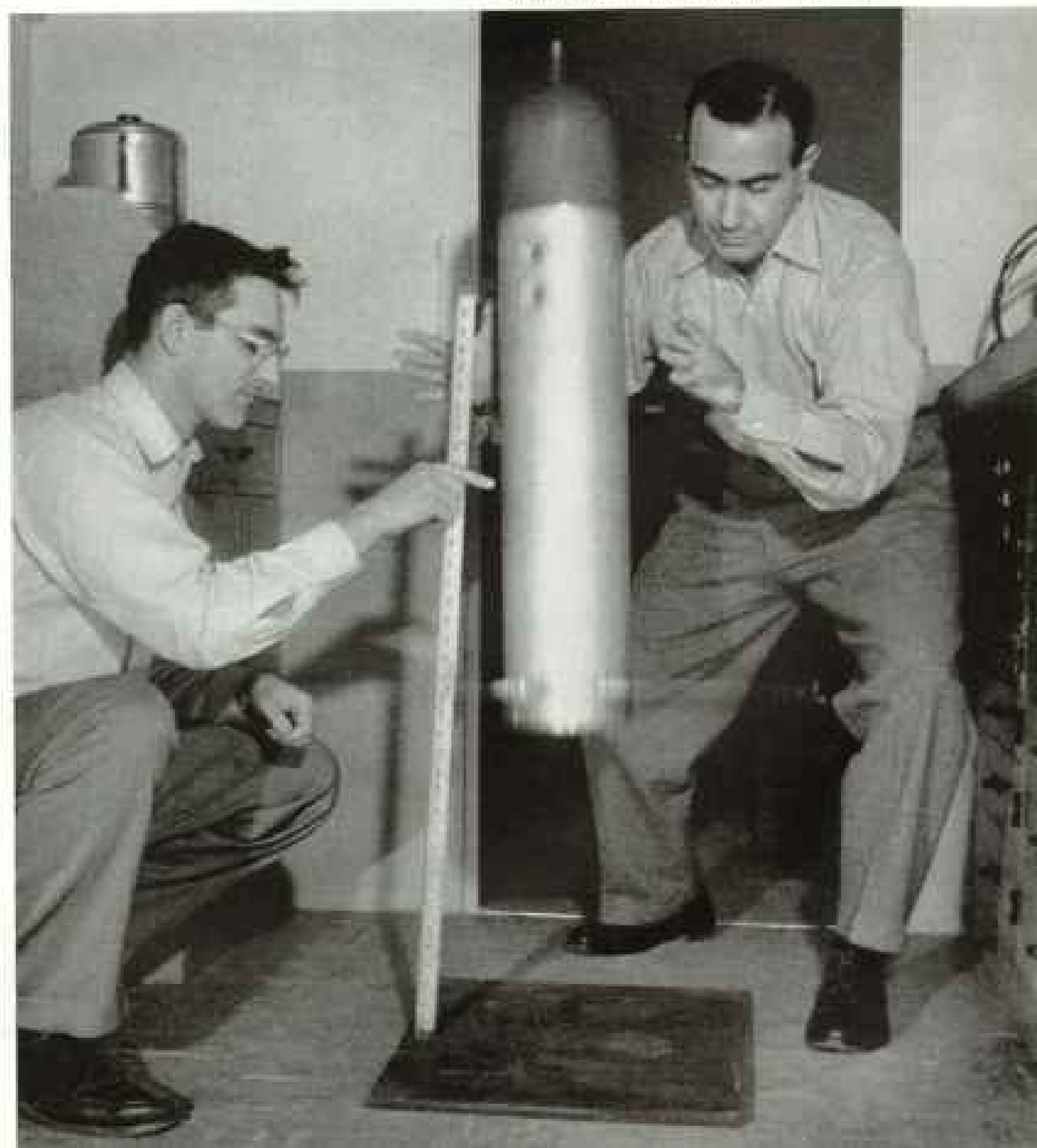





572

Scientists Weigh an Aerobee on Fore-and-aft Scales to Find Its Center of Gravity





573

### This 26-foot Lance Will Probe the Sky

Built by U. S. Army engineers, this launching site at Canada's Fort Churchill will fling more than 30 Aerobees and 42 smaller rockets into the sky during the forthcoming International Geophysical Year.

The rockets will record temperature, pressure, and density of the high atmosphere, chart winds that churn the air 50 to 150 miles above the subarctic, and perform other tasks.

Rocket above was designed to measure the earth's magnetic field and low-energy particles in the aurora borealis, or northern lights.

Unlike a guided missile, the Aerobee has no internal control system to keep it on course. Its center of gravity, like an arrow's, must lie ahead of the center of pressure; otherwise the rocket will tumble end over end. Men weigh the rocket without fuel; its most critical moment occurs just as the propellant burns out.

→ Edith Meadows, physicist at the Naval Research Laboratory in Washington, D. C., is a specialist in upper atmosphere composition. She helped to design and assemble an intricate apparatus known as a mass spectrometer. Installed in rockets, spectrometers enable scientists to analyze gases at high altitudes.

Here, at Fort Churchill, Mrs. Meadows prepares to fit the instrument-bearing nose cone onto the rocket. This missile soared 157 miles, setting a new altitude record for the launching site (page 570).

### ← Experts Inspect a Rocket's Brain

Mrs. Meadows explains the spectrometer's operation to Dr. Joseph Kaplan (left), Chairman of the United States National Committee for the IGY; Dr. Donald C. Rose, of the Canadian National Committee; and Lt. Gen. James M. Gavin, Chief of Research and Development for the U. S. Army.

*Newman Damstra*





### ↑ Navy Men in Plastic Suits Fuel Rockets in a Launching Tower

Fort Churchill's 120-foot tower suggests a giant oilcan (opposite). This crew in the base of the tower prepares a rocket for take-off. Working atop metal platforms spaced at eight-foot intervals, the men pump nitric acid into the rocket's tanks. Helmets and suits protect against the corrosive fluid.

← P. H. Wyckoff (foreground), chief Air Force scientist at Fort Churchill, watches the fueling crew on his television screen in a blockhouse. During firing, all personnel must take cover in this shelter.

→ A Navy Aerobee-Hi blasts off from the tower. Top fins belong to rocket itself; lower set is attached to a booster that propels the missile for the first 2½ seconds, then drops away. Smoke from the booster pours from cracks in the stack and blast doors at the base. Flying fragments are insulation from doors.



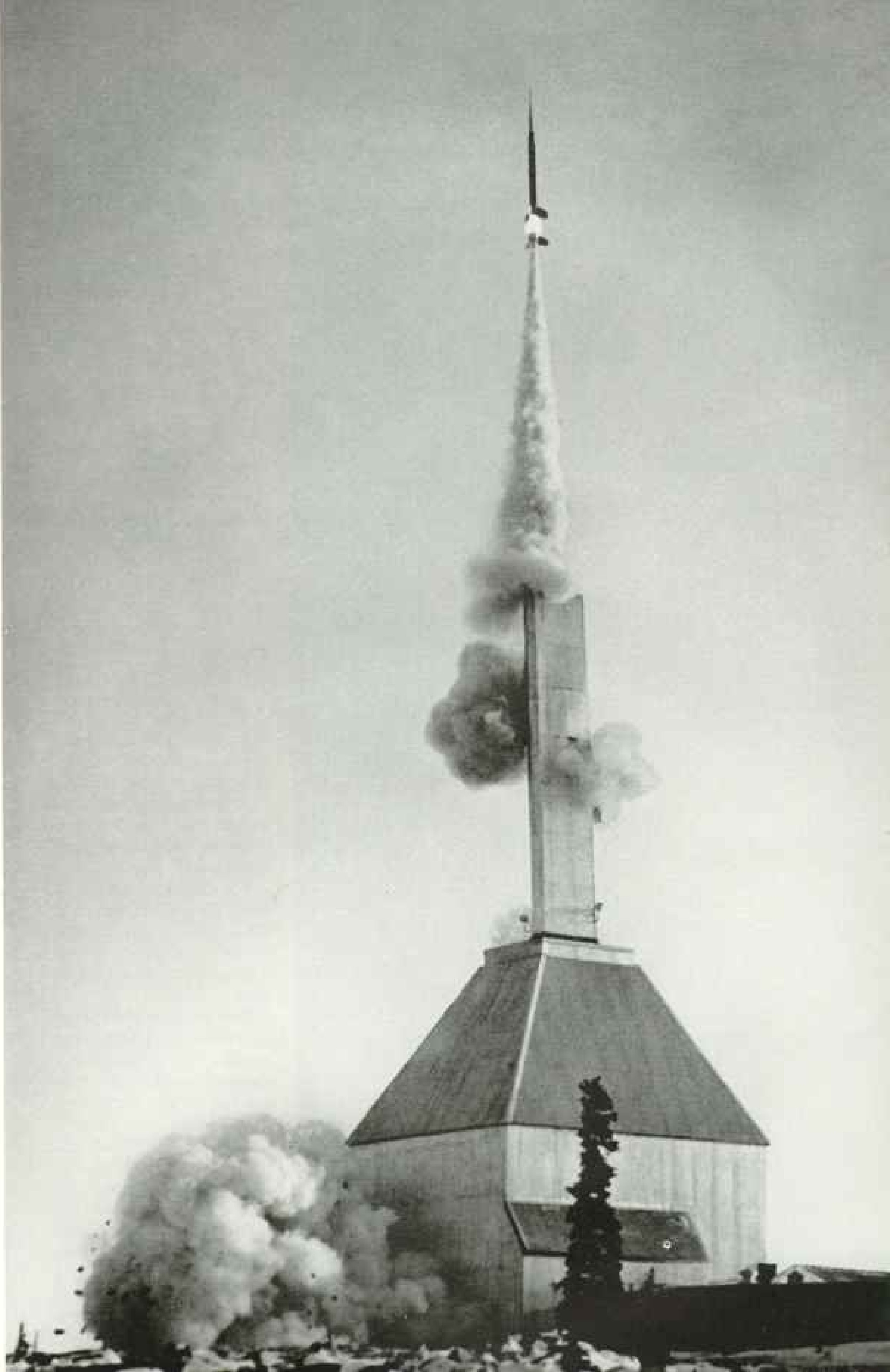



## Rocket's Fiery Trail Streaks the Night Sky

Roaring up from snow-swept plains near Hudson Bay, the Aerobee raced through thin clouds at 5,000 feet, crossed the moon's overcast face, and climbed 157 miles. Here its exhaust trail fades out at 30,000 feet.

→Dovap, an electronic system developed by the Army's Ballistic Research Laboratories at Aberdeen, Maryland, measures a rocket's position in space. Dovap sends up radio waves that the rocket receives and rebroadcasts back to earth. Changes in the missile's speed produce wave effects that register on screens in ground stations.

Here the author (right) follows a rocket's flight at Fort Churchill. Harold Zancanata, chief of Dovap operations, telephones to the launching tower.

Below: Oscilloscopes show Doppler frequencies—and hence the velocities—of a rocket in motion. Jagged peaks at top reveal high speed. Rounded humps below indicate a slow-up.

—J. D. Simpson, *Newman Illustrated*—

576

The rocket began its downward fall, and again the moan became audible. Its pitch rose higher and higher, becoming an eerie shriek which ended only when the monster plunged into Hudson Bay.

I breathed a sigh of relief. Throughout the flight I had experienced a horrible sensation of being in the rocket, and I was glad to have it over.

During the flight's seven minutes—pay-off for months of preparation—Spencer stood with eyes glued to an instrument that looked like a TV screen. It told him all was well in the rocket-borne laboratory. When the flight was completed, he looked like a man whose wife had just presented him with triplets—pleased, but too awed to smile.

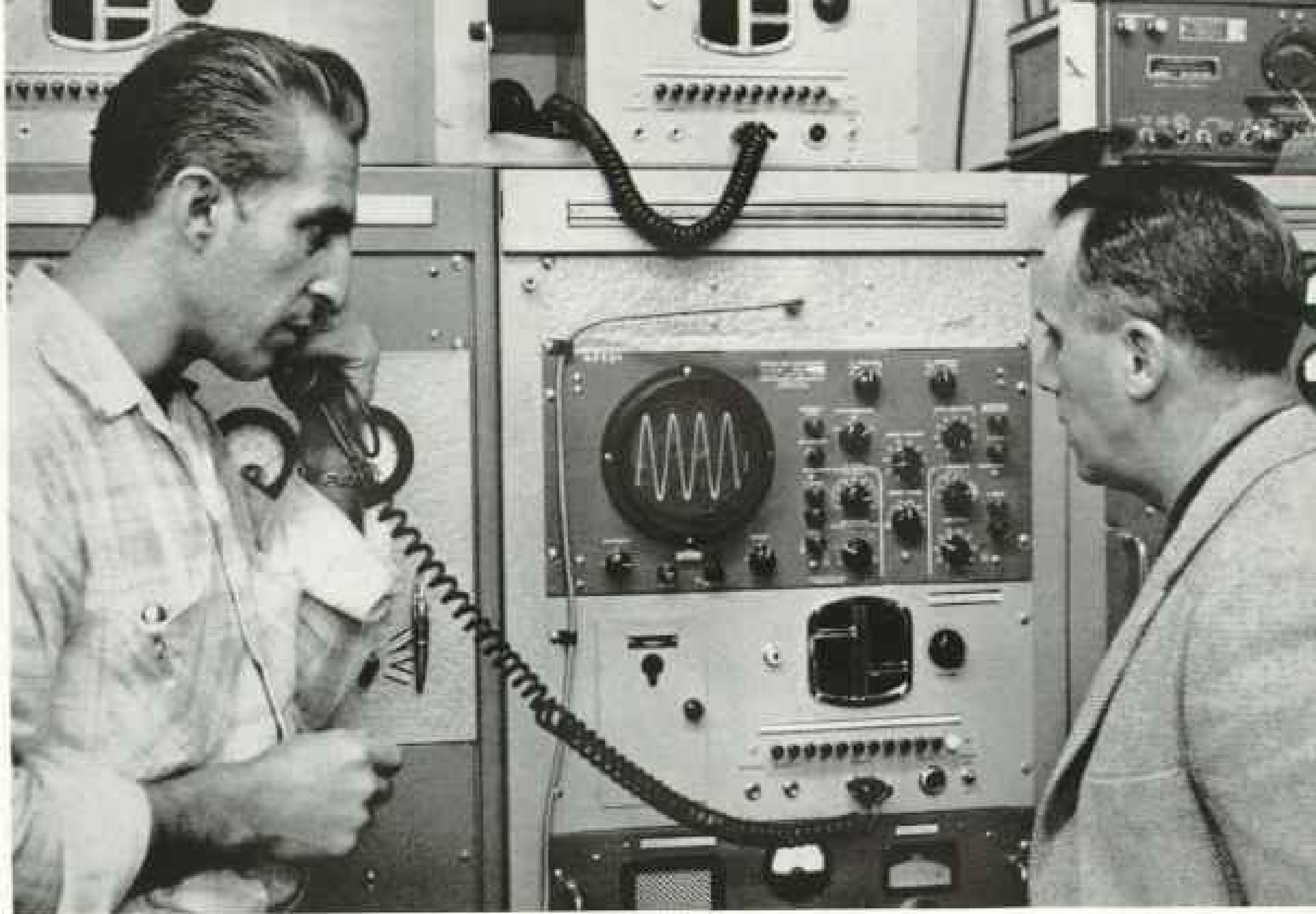

577

There was no need to recover the rocket's instruments from the bottom of Hudson Bay; they had "talked" their findings down to earth by telemetering instruments. The story would be told by wavy lines on film.

I next saw Mr. Spencer weeks later.

"How much colder was it in the ionosphere than on the ground at Fort Churchill?" I asked.

"We don't know yet," he answered. "It'll be months before we have our data analyzed, but they probably will show temperatures to be around  $0^{\circ}$  F. at 65 miles."

Balloon flights have shown that temperatures drop as low as minus  $90^{\circ}$  F. at altitudes of seven to ten miles. Rocket flights have revealed that higher up the air becomes warmer, approaching ground level temperatures at 30 miles. Why? Because at that altitude ozone absorbs the sun's ultraviolet energy and converts it into heat.

#### Air Ocean Is Both Cold and Hot

Another drop in temperature occurs above 30 miles, again reaching a low of about minus  $90^{\circ}$  F. at 50 miles. From 30 miles on out the temperature rises once more. How far into space this rise continues, scientists do not know for sure, nor can they explain it to everyone's satisfaction. They believe temperatures may reach  $2500^{\circ}$  F. or more at the outer limits of the ionosphere.

Speeding at 3,500 miles an hour, the rocket developed such tremendous air friction that its surface temperature rose hundreds of degrees. Yet instruments in its nose cone determined outside air temperatures, independent of the missile's heat.

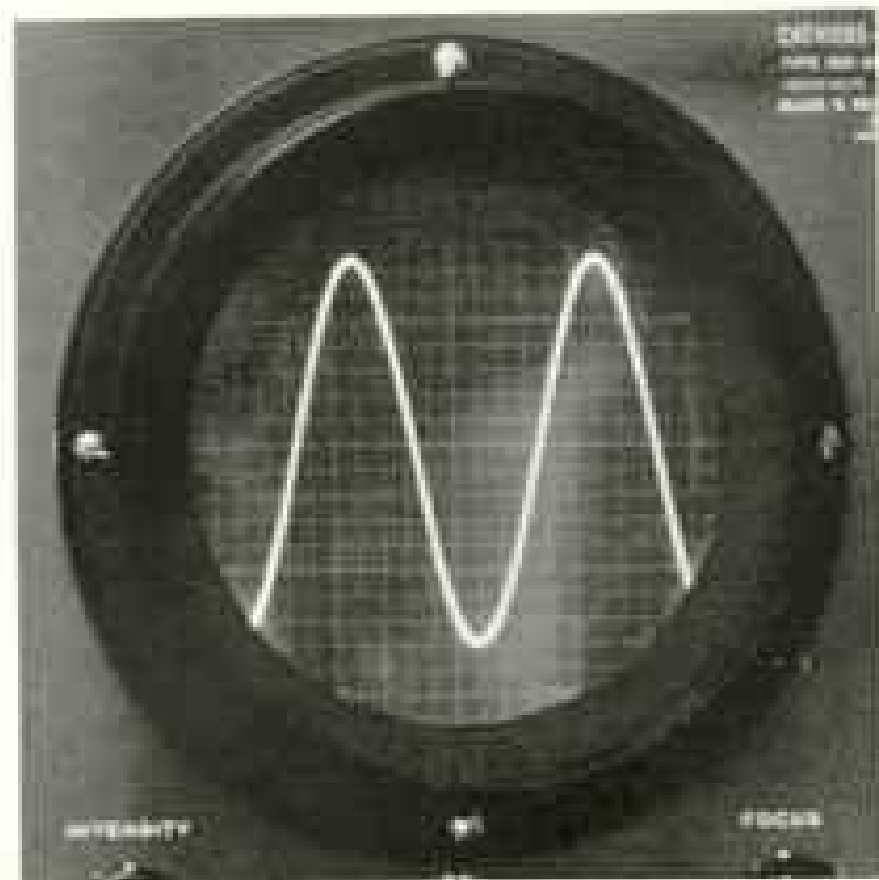
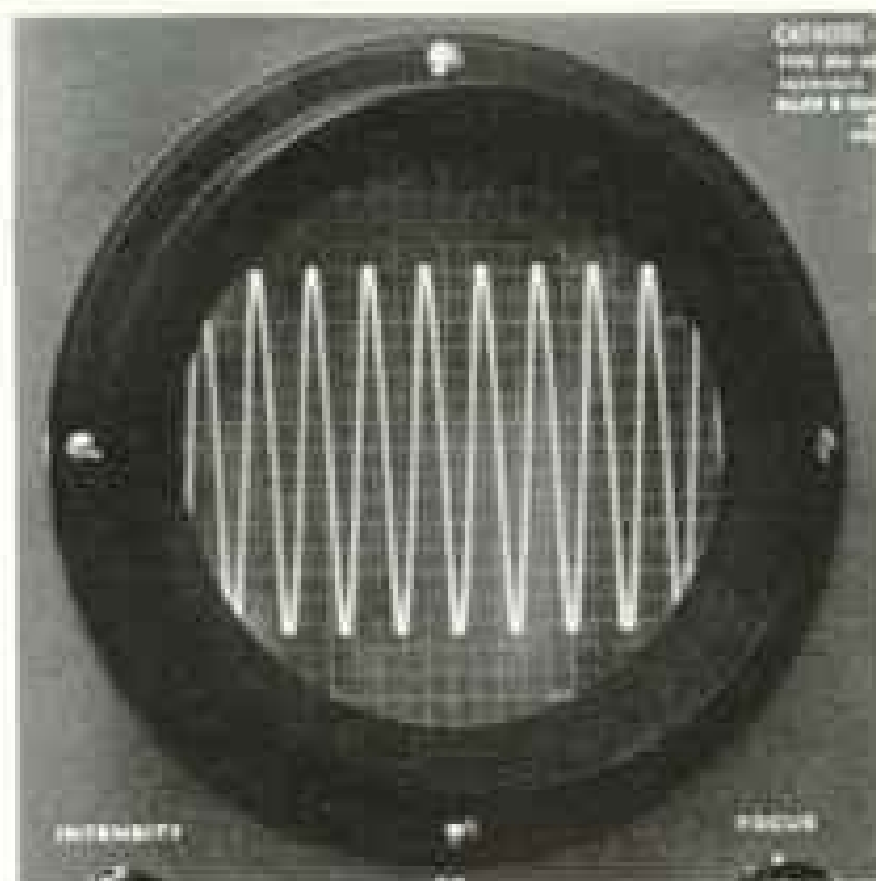

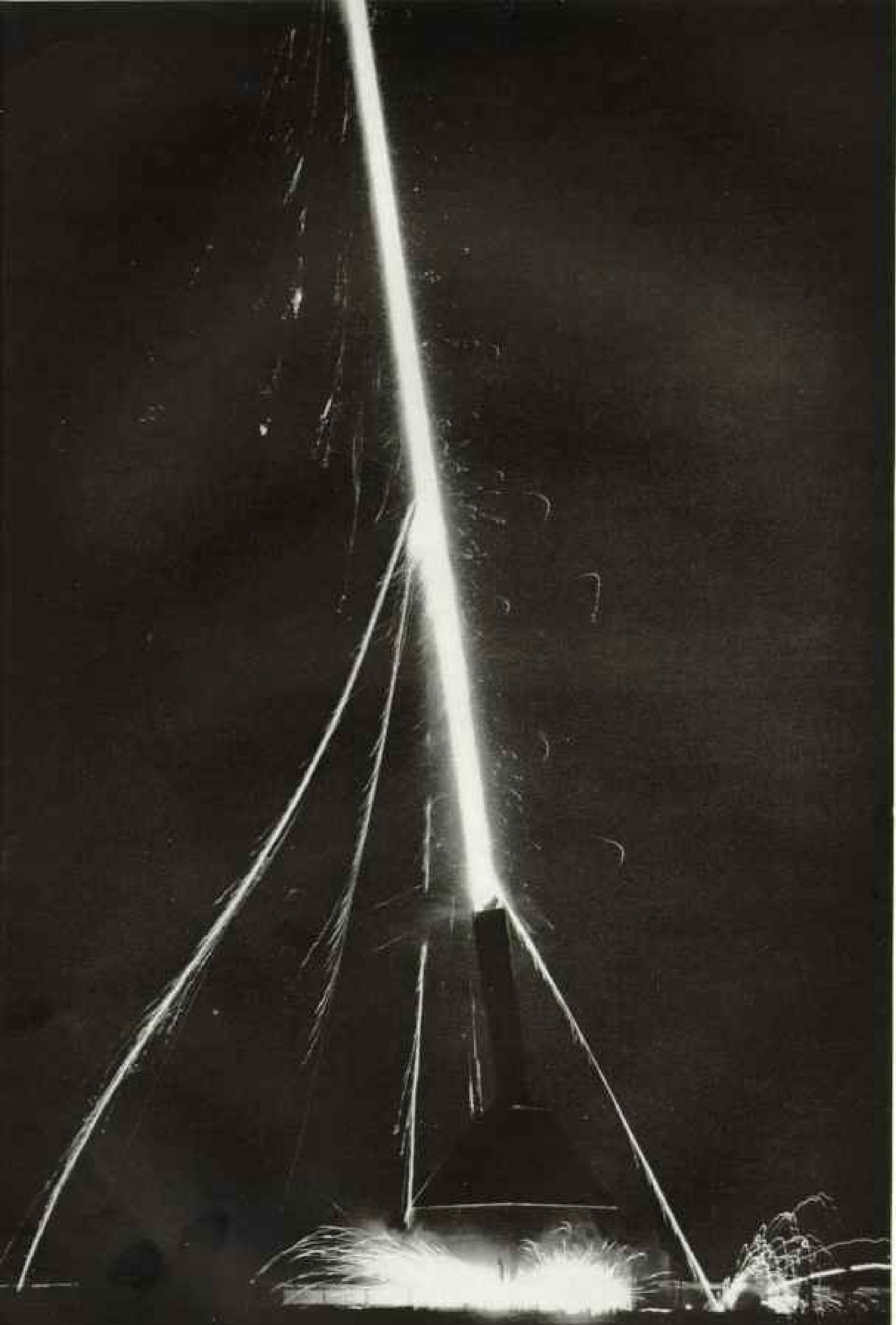

These instruments measured pressures during the roller-coaster ride up and down. The air stream around the speeding rocket had a force equal to 40 hurricanes. Five ports, one on the rocket's tip and four 20 inches aft, were designed to reveal pressures of undisturbed air, as if the screaming rocket had not been there.

Not all upper atmosphere research goes as smoothly as the test I watched in Canada.

At Holloman Air Development Center in New Mexico, I watched as a scientist, Adolph Jursa, mounted a spectrograph in the nose of an Aerobee. This was no ordinary instrument. It was capable of detecting minute amounts of gases in the high atmosphere by observing missing portions of the sun's spectrum, which are absorbed by the gases.

#### Speeding Rocket Stares at the Sun

No matter how the rocket that carried it might careen or spin, the spectrograph must point at the sun. To lick this problem, Russell Nidey and other physicists at the University of Colorado had built an almost human device, the "Sun Seeker" (below).

This bewilderingly complex mechanism pops an arm out of the rocket's nose after the rocket is safely above the dense, buffeting

air of the lower atmosphere. In Jursa's case the arm was a spectrograph. The Sun Seeker keeps the spectrograph pointed at the sun by looking at it through photoelectric cells. The instrument's mechanism constantly makes split-second adjustments to compensate for the rocket's spinning and yawing.

The Sun Seeker's accuracy is roughly comparable to that of a sharpshooter on a bronco. Even with his horse bucking 60° back and forth while pinwheeling around 90 times a minute, he holds his gun on the target and scores 7 hits in 10 shots at a 4-inch bull's-eye 100 yards away.

Much impressed with Jursa's and Nidey's ingenuity, I went out to Holloman's desert launching site early one morning to see their instruments flash skyward in the nose of an Aerobee. Instead of staying in the observers' area 1,000 yards back, I joined a camera crew 300 yards from the tower. If the rocket went out of control, I might be on a ticklish spot; but after all, there were lots of other spots in the wide desert for it to hit.

I knew that the rocket leaned away from me a few degrees, so that it would land 20 or 30 miles out. I had also been told that it would seem to be right above me.

"Just keep your eye on the rocket and you

#### ← A Flaming Torch, Aerobee Blasts Off at Fort Churchill

When a cold booster failed to burn its fuel smoothly, chunks of solid propellant flew back and splashed the ground. → Adolph Jursa (right) designed this spectrograph, a complex mechanism here encased in a metal box in a rocket's nose. Its task on reaching the ionosphere is to pop out and analyze sunlight.

To function, the spectrograph must point at the sun. Physicist Russell Nidey (left) helped build a mechanism, the Sun Seeker, that keeps the spectrograph accurately aimed. Like the sun itself, the lamp in his hand excites the Seeker's photoelectric cells.

Here at Holloman Air Development Center, New Mexico, the two men prepare their instruments for flight. Later a misfiring dashed their work to pieces. Undaunted, they went home to do the job anew.

← U. S. Army, Official R. F. Stearns







### Rocket's 80-mile Plunge from the Ionosphere Left This Battered Hulk

Engineers rigged a parachute in the head of the Aerobee, hoping to save the instrument-carrying nose cone. However, the missile head, too heavy for the chute, crashed on the Holloman firing range in New Mexico. These Air Force men flew in by helicopter to recover the wreckage. Mist dims the distant peaks.

can tell if it's coming toward you," said a cameraman comfortingly.

As I listened to the count-down, I looked for shelter and edged toward a heavy Dodge truck.

"...Minus one...zero!"

The rocket belched flame, seemingly in silence. A second later its rupturing blast reached me. Now it streaked skyward, trailing ominous black smoke. Yes, the cameraman was right. It seemed to be right above me. Seemed to be? Suddenly I realized it really was above me. I glanced quickly at the man beside me, looking for signs of alarm. At that instant he shouted, "Hit the dirt! It's coming down!"

I looked up again in near panic. I couldn't see the rocket, but its increasing roar left no doubt that it was coming down, and fast.

I threw myself under the truck and found others there ahead of me.

Seconds passed as the rocket screamed earthward...a terrifying explosion...then

silence. The rocket had landed about 400 yards to our rear.

I looked out from under the truck to see a cloud of dust and smoke floating away in the morning breeze—the end of Jursa's spectrograph, the end of Nidey's Sun Seeker, the end of months of work and planning.

### Rocket's Death Only a Temporary Defeat

Shocked with sympathy, I met them coming out of the blockhouse. Strangely, they didn't seem as upset as I was.

"We have to live with this," said Jursa. "We know it can happen."

"What now? Will you abandon the experiment?" I asked.

And the answer I got is eloquent testimony to the tenacity and inflexible determination of the scientists who probe the secrets of the earth's atmosphere.

"No. We'll start building new instruments. Perhaps we'll be ready again in six or seven months."

# NATIONAL GEOGRAPHIC SOCIETY

SIXTEENTH AND M STREETS NORTHWEST, WASHINGTON 6, D. C.

MELVILLE BELL GROSVENOR, President and Editor  
ROBERT V. FLEMING, Treasurer  
HILLIARY F. HOSKINSON, Assistant Treasurer  
WILLIAM H. McCAULEY, Assistant Treasurer  
LYMAN J. BRIGGS, Chairman, Research Committee  
ALEXANDER WETMORE, Vice-Chairman, Research Committee  
HERMAN J. A. C. ARENS, Executive Assistant to the President and Editor

THOMAS W. McKNEW, Vice-President and Secretary  
MELVIN M. PAYNE, Senior Assistant Secretary  
VERNON H. BREWSTER, Assistant Secretary  
ROBERT E. DOYLE, Assistant Secretary  
SIBYL PECK, Assistant to the Chairman of the Board  
LEON J. CANOVA, Assistant to the Vice-Chairman

## BOARD OF TRUSTEES

### GILBERT GROSVENOR

Chairman of the Board, Formerly President, National Geographic Society, and Editor of Its Magazine (1899-1954)

### JOHN OLIVER LA GORCE

Vice-Chairman of the Board, Formerly President and Editor, National Geographic Society (1954-1957)

GEORGE C. MARSHALL  
General of the Army  
Formerly Secretary of Defense

### CURTIS E. LEMAY

Commander in Chief  
Strategic Air Command

### EMORY S. LAND

Vice Admiral, U. S. Navy  
Retired, Formerly President  
Air Transport Association

### LYMAN J. BRIGGS

Director Emeritus, National  
Bureau of Standards

### LEONARD CARMICHAEL

Secretary  
Smithsonian Institution

### BENJAMIN M. MCKELWAY

Editor, The Washington Star

### ROBERT V. FLEMING

Chairman of the Board  
Bills National Bank

### THOMAS W. MCKNEW

Vice-President and Secretary  
National Geographic Society

### ALEXANDER WETMORE

Research Associate  
Smithsonian Institution

### HUGH L. DRYDEN

Director, National Advisory  
Committee for Aeronautics

### JUAN T. TRIPPE

President, Pan American  
World Airways

### MELVILLE BELL GROSVENOR

Editor, National Geographic  
Magazine

### LLOYD B. WILSON

Honorary Chairman of the Board  
Chesapeake and Potomac  
Telephone Committee

### L. O. COLBERT

Rear Admiral, U. S. Coast  
and Geodetic Survey, Retired

### RICHARD E. BYRD

Rear Admiral, U. S. Navy, Retired

### LEROY A. LINCOLN

Chairman of the Board  
Metropolitan Life Insurance Co.

### CHARLES F. KETTERING

Consultant and Director  
General Motors Corporation

### EARL WARREN

Chief Justice  
of the United States

### H. RANDOLPH MADDOX

Vice-President  
American Telephone  
and Telegraph Company

### WILLIAM E. WRATHER

Director, U. S. Geological  
Survey, Retired

### ELISHA HANSON

Lawyer and Naturalist

### ERNEST E. NORRIS

Retired President  
Southern Railway System

Trustee Emeritus: WILLIAM V. PRATT, Admiral, U. S. Navy, Retired

## ORGANIZED FOR "THE INCREASE AND DIFFUSION OF GEOGRAPHIC KNOWLEDGE"

To carry out the purposes for which it was founded 69 years ago, the National Geographic Society publishes the National Geographic Magazine monthly. Receipts are invested in The Magazine or expended to promote geographic knowledge.

Articles and photographs are desired. For material The Magazine uses, retention consideration is made.

In addition to the editorial and photographic surveys constantly being made, The Society has sponsored more than 100 scientific expeditions, some of which required years of field work to achieve their objectives. It has aided and encouraged exploration literally to the ends of the earth, having contributed to expeditions of Rear Admiral Robert E. Peary, discoverer of the North Pole, and Rear Admiral Richard E. Byrd, first man to fly over the North and South Poles.

Photomapping the heavens to a depth of a billion light-years from Palomar Observatory, the National Geographic Society and California Institute of Technology have expanded the known universe at least 25 times and discovered tens of thousands of giant star systems. This seven-year Sky Survey (1949-1956) has made available to observatories all over the world the most extensive sky atlas yet produced.

In Russell Cave, Alabama, in 1956, an archeological expedition of The Society and the Smithsonian Institution excavated the oldest material of human origin yet found east of the

Mississippi—charcoal from cooking fires of 8,000 years ago. The site revealed a unique record of man's occupancy from 6200 B. C. or earlier until about A. D. 1650. Finds included many artifacts, weapons, and the 4,000-year-old bones of a man and a dog.

National Geographic exploration and scientific study made known to the world the natural wonders now preserved as Katonah National Monument and Carlsbad Caverns National Park.

The Society's notable expeditions pushed back the historic horizons of the Southwest to a period nearly eight centuries before Columbus by dating the vast ruins of Pueblo Bonito.

In Mexico, The Society and the Smithsonian Institution, January 19, 1930, discovered the oldest dated work of man in the Americas. This stone is engraved, in Maya-like characters, November 4, 291 B. C. (Spinden correlation). It antedates by 200 years anything else in America bearing a date and reveals a great center of early American culture, previously unknown.

On November 11, 1933, the stratosphere flight of the world's largest balloon, *Explorer II*, sponsored by The Society and the U. S. Army Air Corps, reached a world-record altitude of 72,395 feet. Capt. Albert W. Stevens and Orvil A. Anderson recorded scientific results of extraordinary value.

The Society and individual members contributed \$100,000 to help preserve for the American people the finest of California's sequoias, the Giant Forest in Sequoia National Park.

## EXECUTIVE STAFF OF NATIONAL GEOGRAPHIC MAGAZINE

### Assistant Editors

ROBERT LESLIE COMLY  
GEORGE W. LONG  
FREDC SHUB

MAURON SUTHERLAND

### Senior Editorial Staff

BEVERLEY M. BOWEN  
ANDREW H. BROWN  
ALLAN C. FISHER, JR.

### Foreign Editorial Staff

W. ROBERT MOORE, Chief  
DAVID S. BOYER  
LUCIE MARIEN  
JEAN BOWEN SMITH  
HOWELL WALKER

### Editorial Staff

JIMMY R. HOPKINS  
JAY JOHNSON  
STUART F. JONES  
SAMUEL T. KENNEDY  
SAMUEL W. MATTHEWS  
MATT C. McDANIS  
CAROLYN B. PATTERSON  
JOHN SCHEFFOLD  
MARRIE SEVORY  
KENNETH F. WEAVER  
PETER T. WHITE  
ROSE T. MACHRYNE, Asst.

### Editorial Research

IRIS B. RYAN, Chief  
MARGARET G. BLISSON  
Geographic Research  
GEORGE CHOSSETTE, Chief  
LOUIS F. ALTHOFF  
NEWTON V. BLAKESLEE

### MELVILLE BELL GROSVENOR, EDITOR

THOMAS W. MCKNEW, VICE-PRESIDENT AND SECRETARY

FREDERICK G. VOSBURGH, ASSOCIATE EDITOR

### Secretary's Staff

Personnel Office

HERBERT T. HENDERSON

### Membership Administration

SHeldon CARY

### Payroll Operations

ETHEL M. LOHMAN

### Accounting

F. CHARLES BROWN, Chief Auditor  
C. VERNON SANDERS, Auditor

### Statistical Control

EVERETT U. BROWN

### Cashier

FRANK S. DYER

### Cost Control

SARICET C. ELLIOTT

### Purchasing

JOHN P. M. JOHNSON

### Administration

WILLIAM T. HELL  
CHARLES F. ALTHOFF

### Membership Fulfillment

ROY J. KLOCKERHORN

### Supervisor of Accounts

DELIA M. HERT

### Advertising

GILBERT G. LA GORCE, Director  
JOHN F. CONNERY, Manager

### Chief Cartographer

JAMES M. DARLEY

### Cartographic Staff

NEWTON BENTLEY, Asst. Chief  
LEVIN E. ALLEMAN  
JOHN J. BRENN  
WILLIAM CHAMBERLIN  
RICHARD DARLEY  
ATHOS D. GRIZZINI  
APRILA HOLSTOCK  
RALPH E. McALLEN  
WALTER K. MOHRMAN

### Typographers

C. K. HENDERSON

### Cartographic Artist

WILLIAM PALDRETH

### School Service

RALPH GRAY, Chief  
WILLIAM C. BAUGHMAN  
ENRIQUE C. CANOVA  
SCOTT HART  
EDWARDS PARK

### News Service

WILSON P. BOOTH, Chief

LORENELLE AIRMAN

### Librarian

ESTHER ANN MANNING

JULIA F. BARKS, Asst.

### Printing Production

DEE JAMES ANDRELLA  
JOE M. BARTLEY

### Illustrations Editor

WALTER MEATERS EDWARDS

### Assistant Illustrations Editors

KIP ROSS  
ANDREW POGGENSEN  
HERBERT S. WALKER, JR.

### Illustrations Staff

CHARLES ALLMON  
ROBERT L. BREEDEN  
WILFRED E. CLARKE  
LEONARD J. GRANT  
GILBERT M. GROSVENOR  
GUYFORD D. HANSHIRE  
GERALDINE LINDER  
CAROL STUDDWELL, Librarian

### Staff Artist and Naturalist

WALTER A. WEAVER

### Staff Photographers

B. ANTHONY STEWART, Chief  
WILLARD E. CUTLER  
JOHN E. FLETCHER  
BATES LITTLEFIELD  
DONALD McRATH  
KAYLEEN REVIS  
JOSEPH BAYLOR ROBERTS  
ROBERT F. SIMON  
VOLKMAR WESTFEL  
M. WOODBRIDGE WILLIAMS

### Photographic Laboratory

EDWIN L. WARDEN, Chief

RICHARD H. STEWART, Asst. Chief

### Film Editor

JOSEPH M. RINGOLT

# 5



Many watches purr along on lifetime mainsprings. Still more are shock-resistant or anti-magnetic or fully adjusted. Some even have 22 jewels. But only Hamilton Five-Feature watches contain all these basics of time-telling dependability. It's a topic your Hamilton jeweler will gladly discuss with you. (Left to right) Pagoda, \$95. Culver, \$85. Vista, \$79.50. Prices include federal tax. Hamilton Watch Company, Lancaster, Pennsylvania.

## HAMILTON



the watch jewelers recommend more often than any other



## World Traveler—the Superb Bolex Movie Camera

Trust the Swiss craftsmanship of a Bolex for the refinements and precision that will make your travel movies clearer, easier, vastly more satisfying. Designed for unusual shooting convenience, Bolex 8mm cameras provide you with more features than other cameras, including such refinements as seven speeds for special effects, optical viewfinder, geared footage counter instead of the customary spring device, instant stop on rundown, and many other touches you expect only from the Swiss. Comparable only

to the finest Swiss watch for craftsmanship, your Bolex comes to you from the house of Paillard, makers of Swiss precision mechanisms since 1814. Prices for the Bolex 8 and 16mm movie cameras range from \$89.95 for the single lens 8mm model C-8 to \$854.50 for the new 16mm, H-16 Reflex. (Camera shown is the B-8 with Yvar  $\frac{1}{4}$ " F:1.9 and  $1\frac{1}{2}$ " F:2.8 lenses, at \$222 complete.) Write today for literature and the name of your nearest Bolex dealer.



**BOLEX** A PAILLARD PRODUCT



PAILLARD PRODUCTS, INC. • 100 SIXTH AVENUE, NEW YORK 13, N. Y. • FINE SWISS MECHANISMS SINCE 1814

# Lawn mowing luxury!



NEW "ACTIVATED" PILOT WHEEL KEEPS LAWN-BOY LEVEL

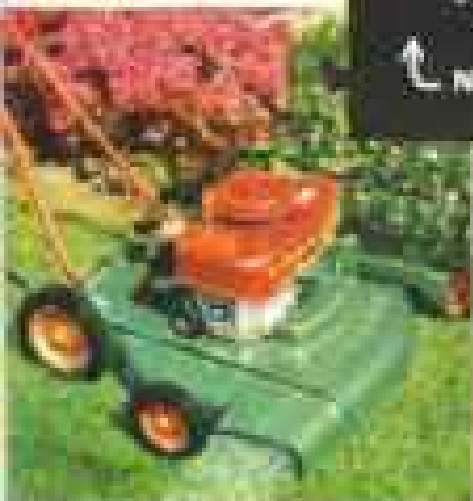

No hand-trimming with LAWN-BOY. Trims to  $\frac{3}{8}$ " of trees, walls, walks.



LAWN-BOY weighs little, works hard, lasts long. It's precision-cast and-machined from special lightweight aluminum alloy.



21" AUTOMOWER . . . IT'S SELF-PROPELLED!

From LAWN-BOY! A new concept in lawn care — Level-cut, smart-looking lawns . . . easily!

Lightweight LAWN-BOYS roll along . . . leaving behind the world's levelest-cut lawns. They're built to do just that . . . designed to make your lawn the beauty spot of the neighborhood. And the new LAWN-BOY AUTOMOWERS eliminate drudgery. They're self-propelled, start instantly and have the simplest, surest control. LAWN-BOY Automowers are available in 18" or 21" sizes. But pick any of the eight beautiful LAWN-BOY models. Your lawn will show the difference . . . for years! Ask your LAWN-BOY dealer for a free demonstration.

## LAWN BOY

LAWN-BOY, Lamar, Missouri • Division of Outboard Marine Corp., makers of *Johnson* and *Evinrude* Outboard Motors. In Canada: LAWN-BOY, Peterborough, Ontario



# BUSINESS CONFERENCE

The never-ending search for oil takes men to strange places—even to ocean floors.

Here Mobil scientists, the first company team of research geologists trained as skin divers, probe the bottom of the Gulf of Mexico.

From their findings have come clues which may lead to the location of new oil reserves to strengthen the Free World—to guarantee you a continuous and abundant flow of the thousands of products made from petroleum to enrich your life.

Training geologists as skin divers is but one of Mobil's pioneering methods of exploring new petroleum frontiers in a world where oil is ever more difficult and expensive to find.

This progressive policy resulted in the first tapping of off-shore oil reserves out of sight of land—another example of Mobil's master touch in oil.

For more information about skin diving for oil, write to Room 2402, Socony Mobil Oil Co. Inc., 150 East 42nd Street, New York 17, N. Y.



SOCONY MOBIL OIL CO., INC.

Leader in lubrication  
for 91 years





# New England has everything!

From historic fishing villages, covered bridges and Bunker Hill to the most modern golf courses, air-conditioned summer theatres and the finest swimming in the world . . . whatever you want, New England's got it!

There's a very special thrill in store when you journey to New England. For here are the quaint and quiet towns where the spirit of America was born.

And for a *perfect* blend of the old and the new, there's nothing like a New England Journey in the new kind of Ford.

You ride in the heaviest, longest, loveliest car the money can buy. And no matter how long or winding your New

England Journey, you arrive refreshed, for you have an all-new *inner* Ford.

Power? Ford's new Silver Anniversary V-8 power was *made* for those new New England superhighways.

If you haven't yet discovered how new this new kind of Ford really is, see your neighborhood Ford Dealer and ask for an Action Test.

Send for a free booklet and map!



Write to:  
New England Journeys, Dept. N  
Back Bay P. O. Box 151, Boston, Mass.

Name \_\_\_\_\_

Street Address \_\_\_\_\_

City \_\_\_\_\_ State \_\_\_\_\_

Ford Dealers of New England

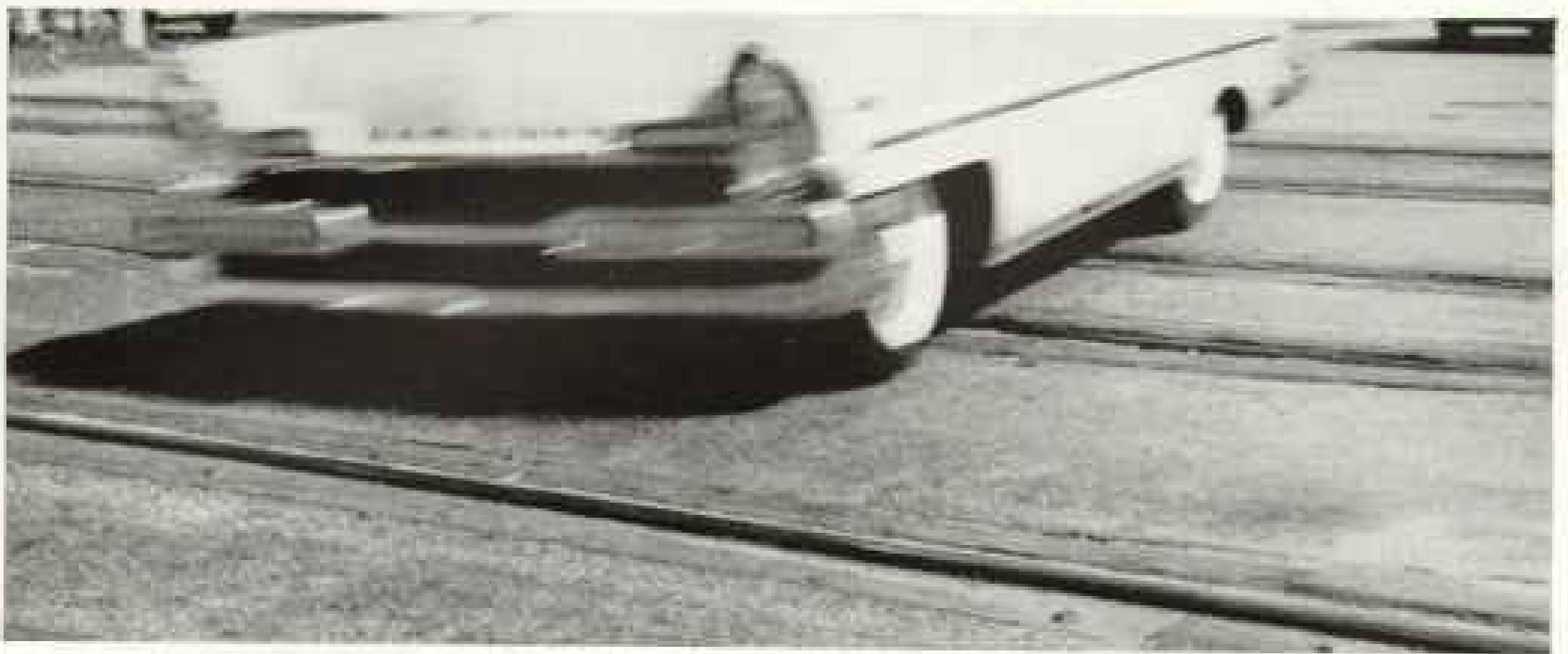

1. You cross a railroad track and hardly notice the bump... thanks to today's smooth-riding cars. But at this instant your tires have taken one of the countless, everyday road shocks that can weaken ordinary tire cord... lead to sudden tire failure when you least expect it.



2. Now you're on the highway where a weakened tire is most likely to blow out. Nylon cord shrugs off day-after-day punishment, gives you protection and confidence. The lasting strength of nylon cord tires has been proved in billions of miles of use by safety-conscious truckers.

## For today's horsepower and highways, you need tires with the lasting strength and safety of nylon cord

Now for today's heavier, more powerful cars, for the sustained speeds permitted on today's highways, there are modern tires with the added safety only nylon can give. Nylon cord protects against the four major causes of blowouts, lets you drive mile after mile with utmost confidence in your tires.

All tire companies make nylon cord tires. Whether you choose premium or standard nylon tires, they offer you greater protection than comparable tires made with ordinary cord. Look for the identification on the sidewall. Insist on nylon when buying new tires—change to nylon when buying a new car.

### NYLON CORD PROTECTS AGAINST THE 4 MAJOR CAUSES OF BLOWOUTS



**1. BRUISE DAMAGE.** Nylon's shock-absorbing toughness protects against impact damage caused by tire hitting a bump, hole or rock.



**2. MOISTURE DAMAGE.** Water can't rot nylon. Nylon ends blowouts due to moisture seeping in through cracks or cuts in tires.



**3. FLEX FATIGUE.** Nylon's resilience guards against the strength-robbing flex strain that wears away little by little a tire's treads.



**4. HEAT DAMAGE.** Nylon gives two-way protection. It not only has greater heat resistance, but also makes cooler-running tires.



BETTER THINGS FOR BETTER LIVING  
... THROUGH CHEMISTRY

**The safest, strongest tires that you can have on your car are made with nylon cord**

Watch Du Pont Shows, Thursday, ABC Network, 8:30-9:30 P.M.

Mention the National Geographic—It identifies you.



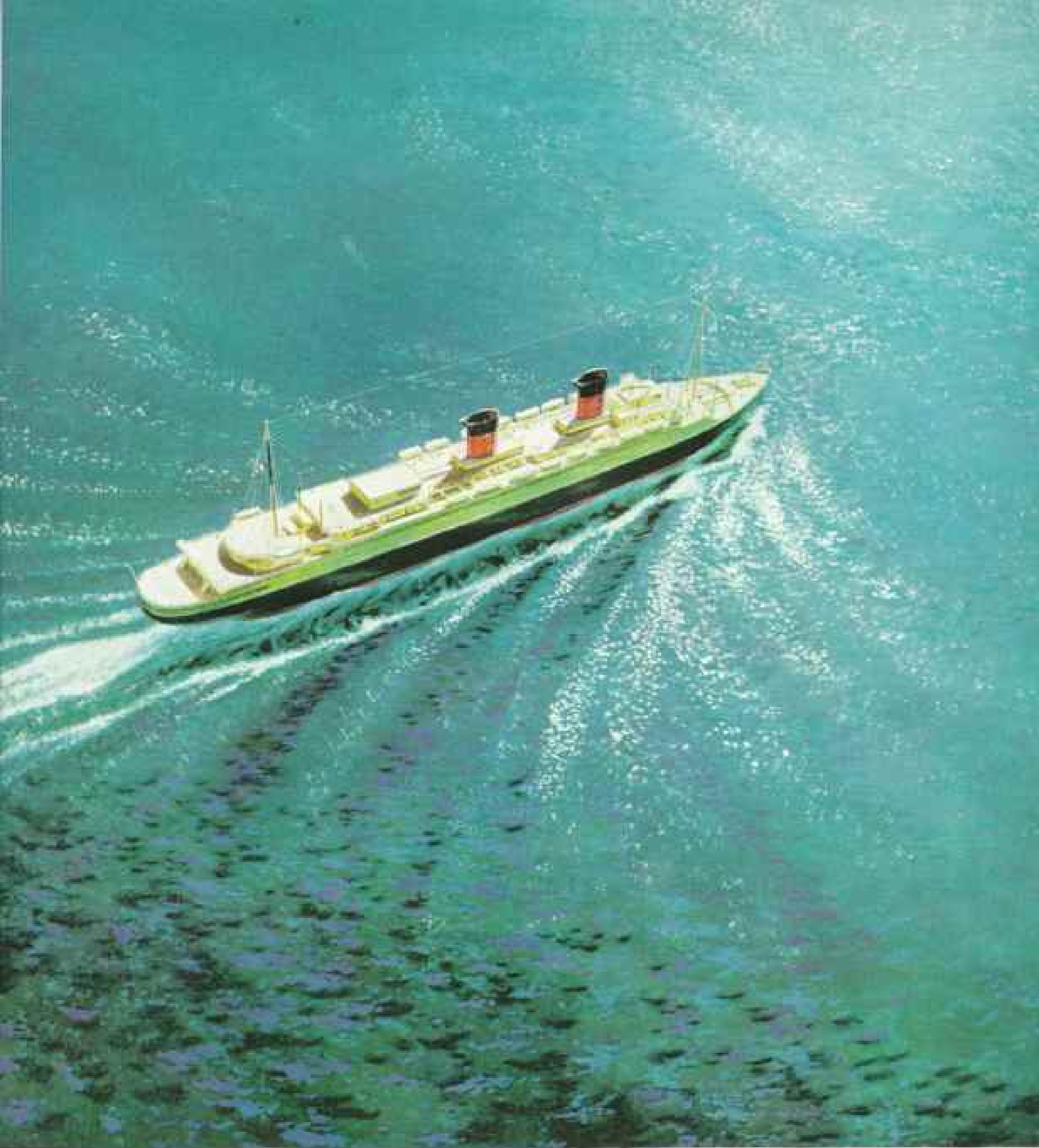

## Greet Europe relaxed and refreshed by France-Afloat



From your deck chair, on a great French Line ship, your eye travels the vast circle of the horizon and you feel the solitude and the solace of the sea. Few things are so relaxing as its infinite rhythm. Your tensions unwind with each whispering wave.

Yet only a step indoors changes your world to merry hours of entertainment and incomparable French cuisine. The days slip astern like flying clouds and you reach port relaxed and readied for the adventures ahead. Consult your Authorized French Line Travel Agent.

# French Line

810 Fifth Ave., New York 20, N.Y.

# NEW! KODAK SIGNET 40 CAMERA



So smart, simple, sure—it brings home color slides that used to be hard to get! \$69

With the new Kodak Signet 40 Camera, you can take truly magnificent color slides with remarkable ease. For this camera *co-operates* with you in every picture-taking situation. It advances the film quick as a wink. It even gives you your choice of flash reflectors to get the most out of the new midget flashbulbs. So you're almost *sure* to come

back with the pictures you want—every time.

The Signet 40 *feels* as if it were designed for you. And it *looks* it. It's compact, clean-lined—the kind of fine camera you've looked forward to owning. And it's made by Kodak—so you know it's good. \$69.00, including flashholder and two reflectors. See it at your Kodak dealer's.



Three- and four-inch reflectors give maximum brilliance with *both* midget flashbulb sizes.



Quick-action thumb lever advances film, stops automatically. Fast, easy loading. Double-exposure prevention.



Bring together the two images in the rangefinder-viewfinder window—you're in focus! Shoot as close as 2 feet away.



Sharp, fast  $f/3.5$  lens and 1/400 flash-synchronized shutter stop action. Average exposure settings are "color-marked."

ASK YOUR KODAK DEALER ABOUT SMALL DOWN PAYMENT AND CONVENIENT TERMS

# NEW! KODAK 300 PROJECTOR



Ultra-portable—yet shows slides bigger and brighter! Has new Readymatic Changer! **\$59<sup>50</sup>**

Here's a brilliant new color-slide projector that's so compact and ultramodern in design, it stands no higher than a modern telephone, and closes into its own carrying case.

This new Kodak 300 Projector throws *bright* screen images—even at long distances. Gives *big* pictures, too—thanks to its "wide-angle" lens.

Its great new Kodak Readymatic Changer loads up to 36 slides, makes changing simple, sure, smooth. See the great new Kodak 300 Projector at your Kodak dealer's, only \$59.50.

Complete Camera-Projector Outfit, \$128.50.

**EASTMAN KODAK COMPANY, Rochester 4, N.Y.**



So light, so handy—carries like a briefcase. Measures just 11x11x5 inches. Has its own self-cover.

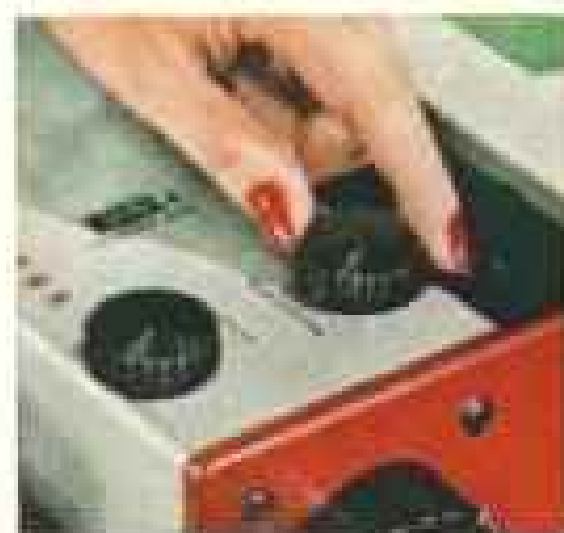

The controls most often used are on top—at your fingertips. Elevation and focusing are simple, one-hand operations.



New Kodak Readymatic Changer is virtually jam-proof. Push-pull action is easy, quick, quiet. *At right*, Kodak 300 Projector with automatic magazine changer, \$69.50.



*List prices include Federal Tax where applicable, and are subject to change without notice.*

**Kodak**  
TRADE-MARK

*My dear  
sincerely yours  
The Editor*

*My dear  
the best of friends  
Respectfully yours  
The Editor*

*Dear Mr. George Highland  
my dear friend  
at the service of your daughter  
Dear Sir*

*My dear Mr. George  
My dear friend*

*My dear Mr. George  
in the service of your daughter  
at the service of your daughter  
Dear Sir*

*My dear  
My dear*



*My dear  
My dear*



*My dear Mr. George*

*My dear Mr. George*

*My dear Mr. George*

# Crane's — FOR YOUR PAPER TROUSSEAU

CRANE'S FINE PAPERS • MADE IN DALTON, MASSACHUSETTS • SINCE 1801

FOR THE FINE PAPERS FOR SOCIAL AND BUSINESS CORRESPONDENCE • JOURNALS • SECURITIES • CARDS • TRADING

# It Gives a Man a New Outlook...



... when he first views the world through the windshield of his own Cadillac car. There is the wholly new sense of pride he feels as he sits in possession of a motor car that is so widely respected. There is the entirely new feeling of mastery he enjoys as he puts the car through its brilliant paces for the very first time. And, finally, there is his

deep pleasure in realizing that he has made one of motordom's soundest investments. And, of course, all of these sentiments will be all the more pronounced for the motorist who makes the move to Cadillac in 1957. Why not visit your dealer and see for yourself? You're welcome to try the view from the driver's seat at any time. CADILLAC MOTOR CAR DIVISION • GENERAL MOTORS CORPORATION

## Cadillac



# UNIVERSAL

## Coffeematic

with the FLAVOR-SELECTOR



CHROME  
ON  
SOLID  
COPPER

No guessing . . .  
no watching . . .  
no reheating . . .  
it's *Completely automatic!*

Coffeematic does it all! Simply set the Flavor-Selector to the strength you prefer and you'll get the same wonderful coffee every time. The fast-starting action never lets coffee boil, giving you full flavor without bitterness. And there's no watching! The Redi-Lite signals when brewing's done and your coffee is kept hot without increasing the strength. Tomorrow, enjoy real coffee made in a Universal Coffeematic.

from \$19<sup>95</sup>  
Ten-cup model shown, \$29.95.  
In copper, \$32.95.

# UNIVERSAL

LANDERS, FRARY & CLARK, NEW BRITAIN, CONN.

**Q:**

"Say, have you heard about the new 8mm movie camera the people who make your '35' just brought out? Sounds like the answer to an amateur's dreams! Has it *really* got the same professional features of your expensive 16mm affair, and is it true they've taken the guesswork out of shooting with it? What's the story?"

## Amateur to Professional Movie-Maker:

**A:**

Well, judging from the write-ups, this turret job will make even *you* look like a pro. You view your subject life-size, keep both eyes open, move as close as 18", and get exactly what you see. No more lopped heads, and no measuring either. With its through-the-lens focusing and—say, why don't we both run down and take a look. You've got *me* interested!"



\$159<sup>50</sup>

with 18mm f:1.8 Canon lens (& wrist strap)

(illus.)  
\$232<sup>50</sup>

with 18mm f:1.8 & 25mm f:1.8 Canon lenses (& wrist strap)

# Canon 8

For the Man  
Going Places  
...with 35mm  
Photography!

## Canon V



CANON Camera Company, Inc.

U.S. Factory Branch: 550 Fifth Ave., N. Y. 36, N. Y.  
In Canada: Taylor & Pearson Ltd., Vancouver, B. C.

**Now available...direct to you from the Publisher**

BRAND NEW EDITION OF THE WORLD FAMOUS

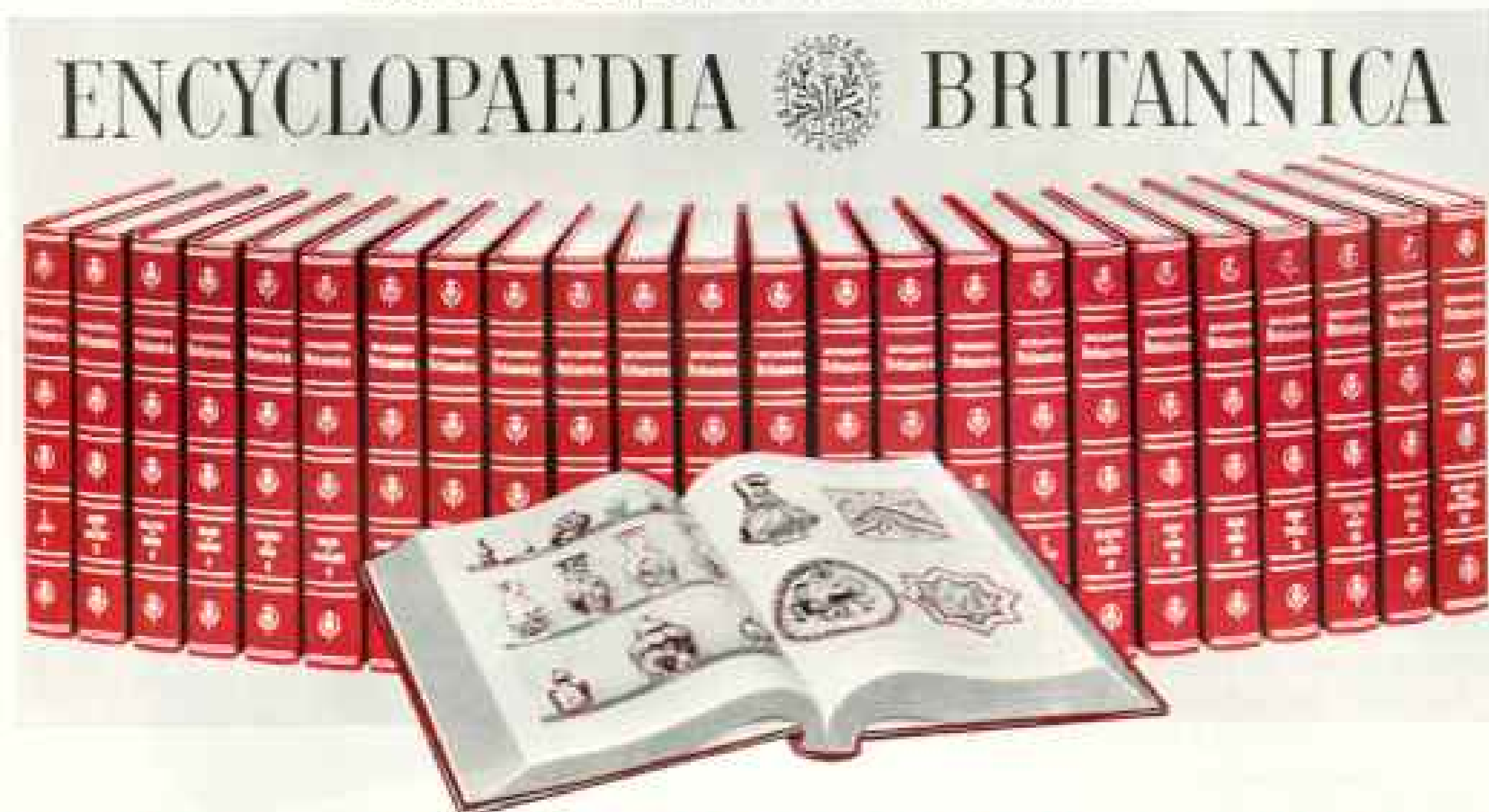

## On Easy...Book a Month Payment Plan

■ Yes, the latest edition of Britannica—the greatest treasure of knowledge ever published—is now being offered on a remarkable, direct-from-the-publisher plan that puts this world-renowned reference library within reach of every family. All 24 volumes will be placed in your home NOW... you pay for it later on convenient budget terms. It's as easy—and as inexpensive—as buying a book a month.

You may wonder how we're able to make this truly amazing offer. First, because of the great demand for this magnificent set, we have ordered a tremendous printing. Also, by offering this set *Direct from the Publisher*, we have saved many distribution costs. These savings are passed on to you.

**Thousands of Subjects of Practical Value**  
In the brand-new edition of Britannica you will find thousands of subjects that you and your family will refer to in the course of your normal day-to-day affairs. For example, you'll find special articles on household budgets, interior decorating, medicine and health, home remodeling, child care, adolescent problems, rules and regulations for all sports, every kind of hobby... plus a treasure house of knowledge on *all* subjects. Useable information that can save you many dollars.

**New Edition is Profusely Illustrated**  
The new Britannica almost "televises" the information to you by means of 23,404 magnificent illustrations. But it does not merely show "attractive" pictures—it is the work of 5,565 of the world's greatest authorities on all information significant to mankind.

**Britannica Often Called Key to Success**  
The brand-new Britannica—the biggest

**Preview Booklet Offered FREE!**

Simply fill in and mail the coupon today, and we will send you... without cost or obligation... a copy of our beautiful, new booklet which contains an exciting preview of the latest edition of Encyclopaedia Britannica. Send no money—not even for postage. It's yours, absolutely free!

In its pages, you will see the most significant scenery on the North American Continent. You'll go on a cruise to France—to the mysterious Orient—to a Pacific Island—or by rocket to the moon!

In color so beautifully etched it gives the illusion of a third dimension, you will see art treasures of famous museums, world landmarks... and scientific wonders.

Just as soon as we receive your coupon, we will send your illustrated free booklet. No obligation, of course. However, since this offer is necessarily limited, please mail the coupon today before it slips your mind.



and greatest edition in our almost 200-year publishing history—is expressly designed to help you enjoy a richer and fuller family life, aid you in achieving greater financial rewards and success in your business or trade, help your children in school, and enable you to speak factually and intelligently on the widest range of subjects.

**FREE Research Service**  
As a Britannica owner, you would be entitled to *free* research reports on subjects of your choice. These comprehensive and authoritative reports are prepared for you by members of the world-famous Britannica Research Staff, and cover any subject of important interest to you.

<b>Mail Coupon Now for Free Booklet</b>	<b>ENCYCLOPAEDIA BRITANNICA, Dept. 67F</b>	
	425 N. Michigan Avenue, Chicago 11, Illinois	
	Please send me, free and without obligation, your colorful Preview Booklet which pictures and describes the latest edition of ENCYCLOPAEDIA BRITANNICA in exciting full detail. Also include complete information on how I may obtain this magnificent set, direct from the publisher, on the Book a Month Payment Plan.	
	Name _____ (please print)	
	Address _____	
City _____ Zone _____ State _____		
In Canada, write H. B. Ltd., Terminal Bldg., Toronto, Ont.		



*it's a snap, Dad, with*

**nomad**



Yep! He's shooting right along with the "expert", because Nomad makes picture-taking a snap... for the whole family! Nomad gets the picture perfectly in black and white or color, in daylight or with flash, and there's nothing to set or fuss with. Just snap!

Include the whole family in the picture-taking fun. See the new Nomad now, at camera stores everywhere.



**NOMAD CAMERA-PAK** holds Camera,  
Film, Flash, Bulbs and Batteries.  
**127 PAK...\$9.25 620 PAK...\$11.25**

Prices slightly higher in Canada. © Sawyer's Inc., Dept. NG, Portland 7, Ore. **NOMAD 127, \$4.95**  
**NOMAD 620, \$6.95; FLASH, \$2.50**

Made and Guaranteed by **SAWYER'S**, Manufacturers of famous View-Master Products

## ANTIQUITY...



## MODERNITY...



## ETHIOPIA OFFERS BOTH!

3,000 years of history. Fine Hotels. Obelisks dating from the Queen of Sheba. An airline which rates with the best. American pilots flying six Convair flights weekly between Athens and the major East Africa cities.

የኢትዮጵያ አየር ማንኛውም

**ETHIOPIAN AIRLINES**

THE WONDERLAND ROUTE

General Agents

In United States and Europe

**TWA**  
TRANS WORLD AIRLINES

# MANITOBA



## UNCROWDED CANADA'S FAVORITE PLAYGROUND

Manitoba—unspoiled, inviting—offers new adventures for a family vacation. Waiting for you are summer sports, sparkling lakes, rugged northland, sandy beaches, modern resorts—and wonderful fishing!

Send for 40-page vacation guide, a preview to your finest vacation!

5122

**MAIL  
COUPON  
FOR  
FREE  
BOOKLET**

Bureau of Travel and Publicity  
707 Legislative Building  
Winnipeg, Manitoba, Canada

Name \_\_\_\_\_

Street \_\_\_\_\_

City \_\_\_\_\_ State \_\_\_\_\_

(PLEASE PRINT)

**INSIDE THE RIM OF ADVENTURE!**



## Close-up or long shot... the view's vivid in Canada



And whatever your holiday pleasure, scenic Canada is the place to enjoy it. You can swim, camp, fish, find nature's noblest exhibits in vast National Parks...relax in glorious lake-

### And cities supply "stoppers" too!

Keep your camera "at the ready" to record the sparkling sights of Canada's cities. They're meccas of modern fun, rich in historic significance—

lands...sample the soft charm of over 59,000 miles of sunny seacoast. Plan to stay as long as you can, see as much as you can of Canada. It's the world's largest natural playground.

and they offer striking shopping opportunities. See your travel or transportation agent soon about a *Canadian* vacation. No passports are needed.

Mail This Coupon For The "Canadian Vacation Package"—A Complete, Free Information Service Containing:

1. "Canada—Vacations Unlimited"—a 48-page booklet with 100 full-colour illustrations, describing holiday attractions in all parts of Canada.
2. "Highway Map" in full-colour of all Canada and northern U.S.A.
3. "How to Enter Canada"...helpful information on border-crossing, etc.
4. "Tourist Enquiry Form" which you can fill out and send in for information on the particular areas, activities, accommodation which interest you.



**Cañada**  
VACATIONS UNLIMITED!



01-1-13-57-04  
CANADIAN GOVERNMENT TRAVEL BUREAU  
OTTAWA CANADA

Please send me—immediately—your free  
CANADIAN VACATION PACKAGE.

Place  
Print  
Name \_\_\_\_\_

Address \_\_\_\_\_

Town \_\_\_\_\_ State \_\_\_\_\_

Stick this coupon on any postcard, or mail it in an envelope.

# ENGLAND

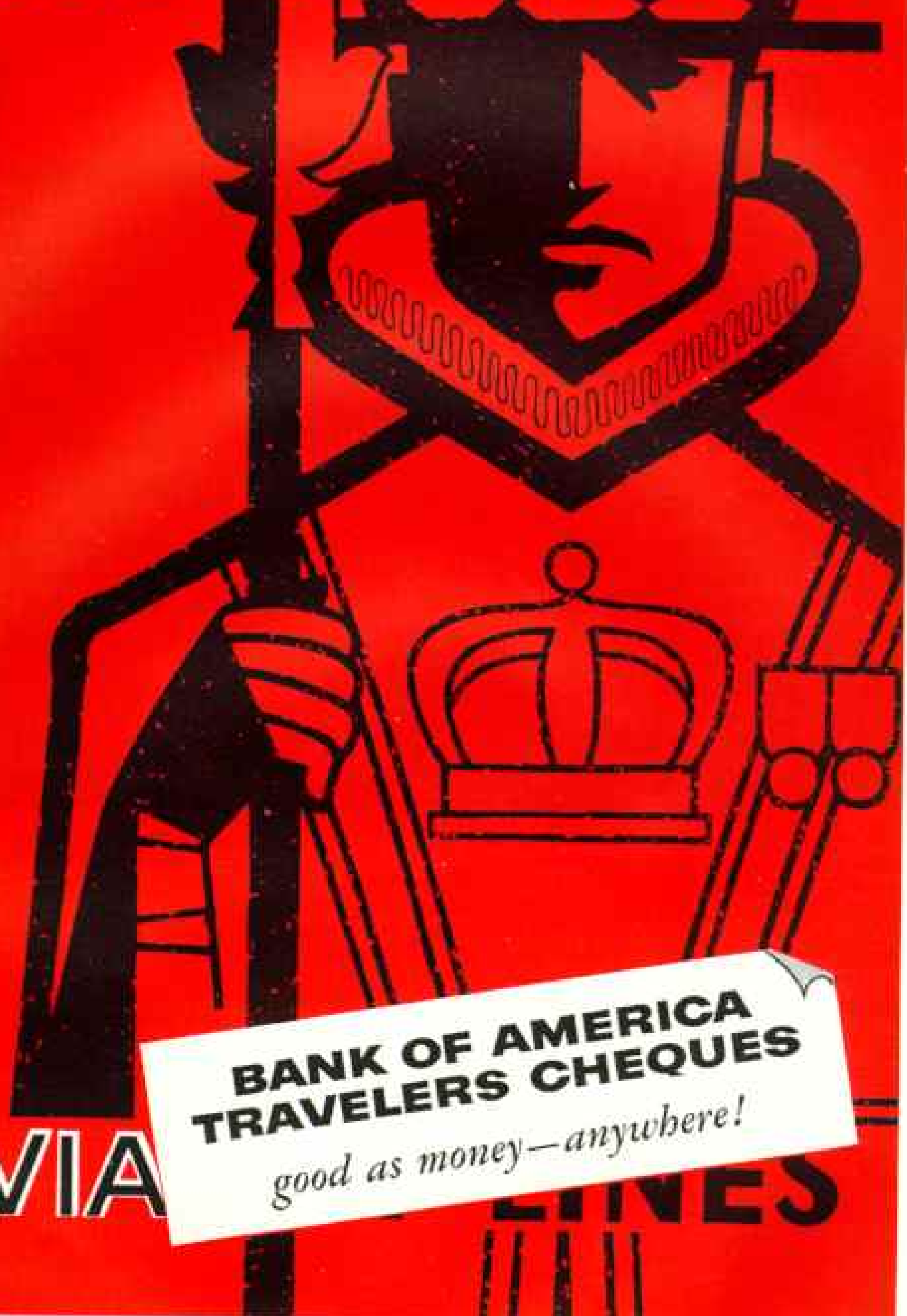

**BANK OF AMERICA  
TRAVELERS CHEQUES**

*good as money—anywhere!*

**VIA**

**ELINES**

TRAVEL CAREFREE—with your funds protected by the world's largest bank! Recognized everywhere, Bank of America Travelers Cheques are sold by your local bank or travel agent.

MEMBER FEDERAL DEPOSIT INSURANCE CORPORATION





Visit picturesque spots along modern highways. See Highland lassies at colourful Scottish gatherings.

Different vacation variety  
in one easy-to-get-to area...

# CANADA'S ATLANTIC PROVINCES



Plan now for something different this year — in Canada's Atlantic Provinces. It's a foreign holiday in a friendly place. Fascinating history is right beside you, yet accommodation is modern, ranging from comfortable to sumptuous. Enjoy a lazy vacation or an action-filled one. No crowds! Come by car, train, bus, plane or ship. No passports needed.



## NOVA SCOTIA

See the highest tides in the world... forty-six to sixty feet. More than 15,000 miles of scenery-bordered highway. Visit fascinating Haliburton and Unlace Museums, and Highlands of Cape Breton. Golf and sail.

## PRINCE EDWARD ISLAND

Eat famous Malpeque oysters. Swim in the warmest salt water north of Florida. Shop for hooked rugs and English chinaware. Sulky racing is a feature of the island...and so is the scenery — restful, pastoral, beautiful!

## NEW BRUNSWICK

You can say you've been to Mermerrammericook and Skoodoowahakock! There are places with names like these. See the world's longest covered bridge. Visit Canada's newest playground — beautiful Fundy National Park. Fish famous salmon pools.

## NEWFOUNDLAND

Explore scenic Newfoundland's 6,000 miles of ruggedly beautiful coastline. Go on cod-fishing excursions. Hunt moose and caribou.

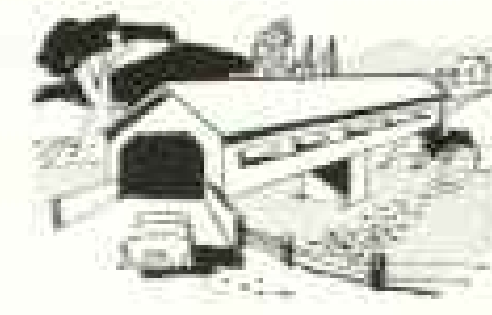

PLEASE P-R-I-N-T

FREE INFORMATION SERVICE  
to help you get the most out of your  
different vacation this year

MAIL THIS COUPON  
for your

"ATLANTIC PROVINCES PACKAGE"  
Fully informative! Fully illustrated!



CANADIAN GOVERNMENT TRAVEL BUREAU  
OTTAWA CANADA

1-02-1

Please send me — immediately — your free  
ATLANTIC PROVINCES PACKAGE

Name \_\_\_\_\_

Address \_\_\_\_\_

Town \_\_\_\_\_ State \_\_\_\_\_

Stick this coupon on any postcard, or mail it in an envelope.



See Britain  
by Rail...  
for 2¢ a mile

On your travel agent's  
**Bargain Counter**

Britain bound? Let your travel agent show you how little it costs to see Britain by rail.

Enjoy the luxury of British trains for only 2¢ a mile—and memorable dining car dinners for little more than *one dollar!*

See Britain by rail and you really *see* Britain. And—you see it at bargain rates.

**On swift, modern British trains** you travel in care-free comfort. Ask your travel agent about train, hotel, and cross-channel ship reservations; tours by rail/motor coach/ship—and direct sea routes to Ireland and the Continent.

**BRITISH RAILWAYS**

OFFICES IN NEW YORK • CHICAGO • LOS ANGELES • TORONTO

Want "planning" literature? Write British Railways, Dept. D-3, 9 Rockefeller Plaza, New York 20, N. Y.



**FIVE IMMEDIATE OPENINGS FOR DESIGN ENGINEERS**

**Senior Missile Airframe Designer.** To develop and test missile structural members, Degree, or equivalent, with at least three years mechanical structural design experience.

**Cockpit Designer and Stylist.** To specialize in functional, attractive cockpit design. Two years experience, industrial styling, plus two years practical design, and strong creative ability.

**Designer For Pilot Escape Systems.** Requires three years engineering experience on pilot escape mechanisms, plus two years in practical design.

**Designer For Ground-Handling Equipment.** To develop tools ranging from special wrenches to engine-change dollies. Opportunity for observation of Fleet operations. Requires engineer with flair for mechanical design and degree, or equivalent experience.

**Electronics Designer For Missile and Piloted Aircraft Check-Out Equipment.** Requires designer with E.E. degree, or equivalent, and three to five years electrical or electronic design experience.

To arrange for a personal interview, or for a prompt report on these or other openings, write or return coupon to:

Mr. J. W. Larson, Asst. Chief Engineer  
Chance Vought Aircraft, Incorporated  
Dallas, Texas

I am interested in a  detailed report  personal interview

on the opening for a \_\_\_\_\_

Name \_\_\_\_\_ Address \_\_\_\_\_

City and State \_\_\_\_\_

NG-1



## *Vought engineer...higher...faster...farther*

He is the man who puts wings on ideas. Through his inventive genius, America is able to maintain peace through preparedness in a complex nuclear age.

He is the man who points the way to tomorrow. His bold approach to the science of flight and to the problems of engineering will bring a better future to all America.

He is the man who has created the remarkable Vought *Regulus* guided missile and the *Crusader* jet

fighter. He is the man who is now working on advanced aircraft types that will fly higher, faster, farther.

*For outstanding opportunities in engineering, write: J. W. Larson, Assistant Chief Engineer, Chance Vought Aircraft, P.O. Box 5907, Dallas, Texas.*

CHANCE **VOUGHT AIRCRAFT**  
INCORPORATED - DALLAS, TEXAS

## NOTED AUTHORITIES

*in 23 fields help you*

## HELP YOUR CHILD

## PLAN A CAREER!

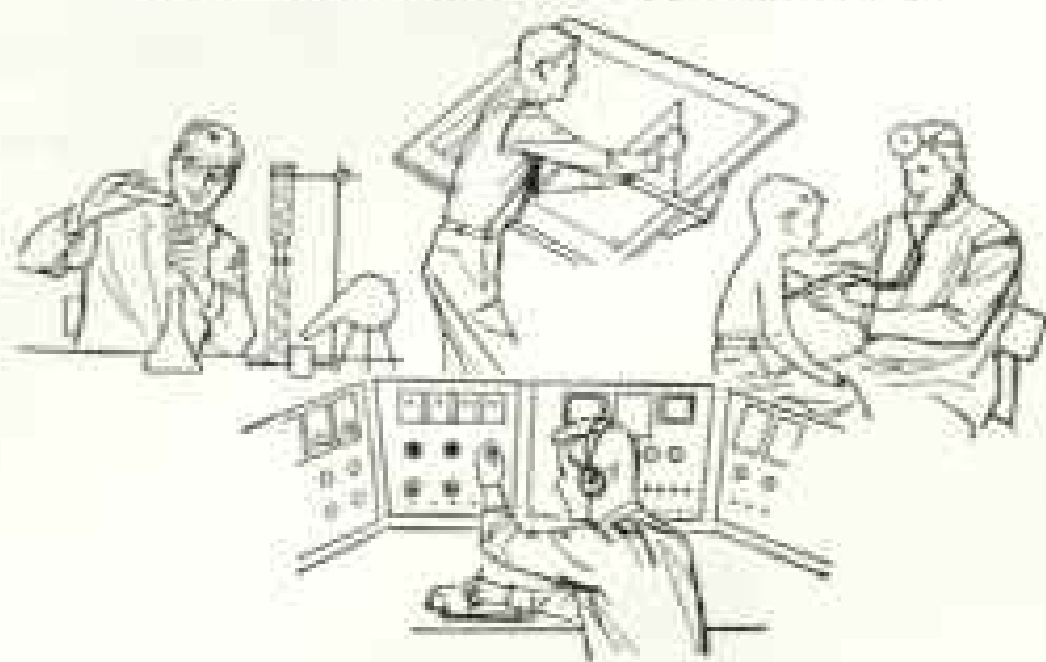

*Send for New York Life's  
23 FREE fact-filled booklets!*

With the aid of these 23 informative booklets now offered *free* from New York Life, you can give your child the guidance he or she needs in selecting a career that will meet his or her particular requirements.

Every booklet has been prepared by a leading authority in his field and contains facts about background and preparation required, as well as rewards that can be expected in each career. Mail the coupon for complete set. There's no obligation!

### HERE ARE THE CAREERS DESCRIBED

Doctor, Lawyer, Chemist, Newspaperman, Accountant, Pharmacist, Public Servant, Aeronautical Engineer, Salesman, Architect, Nurse, Dentist, Teacher, Farmer, Owner of Own Business, Electronic Engineer, Banker, Printer, Home Economist, Mineral Engineer, Atomic Scientist, Personnel Work, Retailing.

- We will also send you a booklet on "The Cost of Four Years of College."

**New York Life**  
Insurance Company

Career Dept. NG-9

51 Madison Ave., New York 10, N. Y.



NAME \_\_\_\_\_

ADDRESS \_\_\_\_\_

CITY \_\_\_\_\_ ZONE \_\_\_\_\_ STATE \_\_\_\_\_

## DON'T GET LOST IN CAR OR BOAT



### NEW NAVIGATOR COMPASS

Ever get lost on a strange road or on a lake in fog or darkness? You won't with this accurate compass. Easy to read—day and night. Liquid-filled dome keeps it steady. Lubber's line and compass rose. Sturdy gray Tenite case, 2½" diameter. Just \$6.95. (In Canada, \$9).

Taylor Instrument Companies,  
Rochester, N. Y., and Toronto, Canada,

**Taylor** INSTRUMENTS MEAN  
ACCURACY FIRST

## Add-a-Coin Bracelet

TRUE AMERICANA  
U.S.A. GOLD COINS 30 TO 100 YEARS OLD  
COLLECTOR'S ITEM

Heavy 14K gold bracelet suspending 100  
U.S. GOLD COINS, or 1000 gold coins.  
Bracelet, one coin \$100—additional coins  
may be added on gift occasions.



(Illustrated  
to size)

Complete  
bracelet  
with 7  
gold coins  
as illustrated  
\$250.

Brochure on Request

## CARTER CARPAC ALL-PURPOSE CARRIER

Full length Station Wagon model shown below



**A Distinctive Cartop Carrier You Will Be Proud To Own**  
Designed not only for carrying capacity but also to enhance the looks of your automobile. CarPac's beautifully varnished wood and sparkling hardware add "Town & Country" look. Models from \$49.50 (Utility Sedan) to \$125 (Full Length Station Wagon). Professional Photographer's Platform model CarPac \$225. Write for folder showing all models including covers. DEALERS: We invite your inquiry. CARTER MFG. CO., 1233 S. E. Division Street, Portland, Oregon

Mention the National Geographic—It identifies you



Catch your breath

*...where there's room to breathe*

In the wide-open Blue Water Country

of the NORTHERN GREAT LAKES AREA!



**MINNESOTA**—where there's room to roam—at 10,000 lovely lakes, Paul Bunyan forests, friendly resort communities. It's for vacationers who love outdoor adventure!



**ONTARIO**—where there's room for restful vacationing—in Canada's uncrowded playground. Explore spectacular waterfalls, lake-dotted forests, historic cities and forts.



**WISCONSIN**—where there's room to relax—the famous meeting ground of the sportman and the musky, the bass, the trout, the walleye—and other hard-fighting fish.



**MICHIGAN**—where there's room for all the family—anywhere along 3,000 miles of broad sand beaches, at thousands of charming lakes, scenic wonders, exciting big cities.

Come North for *real* vacation adventure—and bring the family for the fun!

In these Blue Water lands that border the Great Lakes, you'll test your skill against some of the most competitive fish in America . . . swim, sail, bask on beaches lapped by cool blue waters. Go exploring at fascinating places touched by history, at natural and man-made wonders, in busy big cities, at quiet beauty spots you'll remember forever.

Luxurious hotels, cozy cabins, well-appointed motels, lively resorts—all are designed to satisfy any budget, any taste, any time. Send for the colorful map and literature on any of the four areas. Just mail the coupon.

## NORTHERN GREAT LAKES AREA

MINNESOTA

WISCONSIN

ONTARIO

MICHIGAN



### NORTHERN GREAT LAKES AREA COUNCIL

P. O. Box 6367, Chicago, Illinois

Please send me your Blue Water free travel map and literature on the vacation area checked.

Minnesota  Wisconsin  Michigan  Ontario

Name \_\_\_\_\_

Address \_\_\_\_\_

City \_\_\_\_\_ Zone \_\_\_\_\_ State \_\_\_\_\_

Mention the National Geographic—It identifies you.

# TRAVEL QUIZ (FOR APRIL)



### Our rainiest state is:

- Florida    California    Louisiana

Averaging 55 inches of rain a year, our wettest state is Louisiana. When you cash your First National Bank of Chicago Travelers Checks there or anywhere else in the world, you'll find them accepted easily and quickly. Ask for them at your bank.

### The world's oldest trees are in:

- Japan    United States    Turkey

The oldest known living things, bristlecone pines, more than 40 centuries of age, are found in California. If you travel the scenic West this year, carry your funds in The First National Bank of Chicago Travelers Checks. Only you can cash them. Full refund if lost or stolen.

### Oldest inhabited city is in:

- Egypt    Syria    Greece

Legend says Noah's great grandson founded what is considered the oldest continuously inhabited city—Esh Shum (Damascus) in Syria. When you tour this fascinating area, you'll enjoy your trip more with The First National Bank of Chicago Travelers Checks. Each denomination (\$10, \$20, \$50, \$100) is a different color to prevent errors in cashing.

## The First National Bank of Chicago Travelers Checks



*For All Business and  
Vacation Travel*

MEMBER FEDERAL DEPOSIT INSURANCE CORPORATION

## See Canada

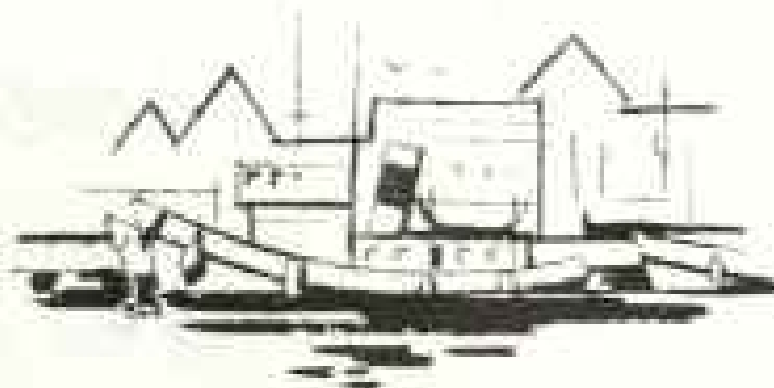

## the Canadian

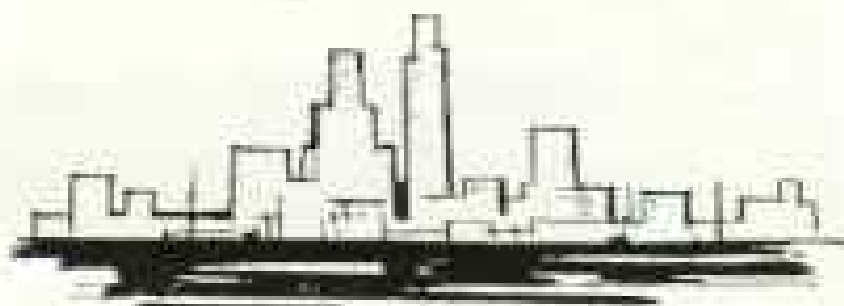

## way...



## DRIVE!



## Canada's Finest Gasolines

Send this handy coupon  
for your **FREE Travel Pack**

B-A Travel Service Bureau, G5134  
British American Oil Building,  
Bay and College Streets, Toronto, Ontario.

Please send me a personalized B-A Travel Pack containing Individual routing maps, Hotel & Motel, Road, and Sightseeing information.

From .....

To .....

Starting Date .....

Name .....

Address .....

City ..... State .....

Mention the National Geographic—It identifies you



How much do you tip  
waiters in Paris?



How do you order  
wine in Rome?



Do's and don't's of  
sight-seeing in Europe



You get all the answers in these new

# TWA TRAVEL GUIDES TO EUROPE



# 25¢ each

SET OF FIVE SHOWN \$1.00

Also available: SPAIN, PORTUGAL and IRELAND  
at 25¢ each . . . order all eight for \$1.50

- Packed with valuable tips—where to go, what to see and do.
- Compact, easy-to-carry, pocket size for prompt reference.
- Simple explanations of customs, currency, eating habits.
- Money-saving tips on where to shop, stay, how much to pay.
- Written, edited by travel experts—complete in every detail.
- Acclaimed by leading travel authorities here and abroad.

(FREE) As a reward for promptness, TWA will send you a full-color map of Paris with every order. Mail coupon today!

*Fly the finest . . .* **FLY TWA**  
TRANS WORLD AIRLINES

**LOOK**  
Page after page of  
information never found  
in travel folders.

**TABLE OF CONTENTS**

General Information	Medical Care
Weather	Useful Addresses
Language	Customs
Prices—Money	Sports
Tipping—Taxis, etc.	Books in Paris
Suway—Bus	Legal Holidays
Rent-a-Car	Church Services
Turkish Bath	Tips for Women
Pressing—Laundry	Travelers
Hotels	
Theatres (Movies—Music Halls)	
Night Clubs—Bars—Cafés	
Shopping (Art to Umbrellas)	
Sight-seeing—Paris and Suburbs	
Sight-seeing—France	

Pyrenees  
valley

UP TO  
**127 PAGES**

### ORDER BLANK

TWA, Trans World Airlines, Dept. N4-7  
P. O. Box 1460, Grand Central Station  
New York 17, New York

Dear Sir: Please send me your wonderful new  
travel guides. I am enclosing cash or check  
(\$1.00 for the five shown, \$1.50 for all eight, or  
25¢ each for single guides) to cover handling  
and mailing costs.

Name \_\_\_\_\_

Address \_\_\_\_\_

City \_\_\_\_\_ State \_\_\_\_\_

Please allow 2 to 3 weeks for delivery

**SET OF FIVE \$1.00**  
Includes France, Great  
Britain, Switzerland, Italy,  
Germany. No substitutions,  
please.

**ALL EIGHT \$1.50**  
Includes the five above, plus  
Spain, Portugal and Ireland.  
Individual Guides, 25¢ ea.

<input type="checkbox"/> France	<input type="checkbox"/> Germany
<input type="checkbox"/> Italy	<input type="checkbox"/> Ireland
<input type="checkbox"/> Great Britain	<input type="checkbox"/> Spain
<input type="checkbox"/> Switzerland	<input type="checkbox"/> Portugal

get ready for a  
dream vacation in

# Colorado

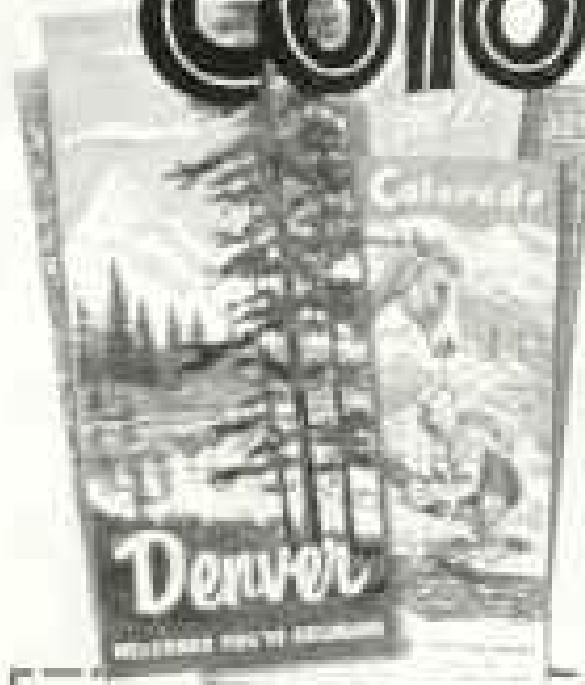

send for

these free information-packed folders about this wonderful vacationland of blue skies, clean cool air and breathtaking mountain scenery. Come early or late ...start planning now.

Denver Convention & Visitors Bureau Dept. 370  
HOSPITALITY CENTER, 225 W. Colfax, Denver 2, Colo.

Send:  Denver Welcomes You to Colorado  
 What to See and Do  Hotel- Motel Directory  
 State Highway Map  Mountain Accommodations

Name \_\_\_\_\_

Address \_\_\_\_\_

City \_\_\_\_\_ State \_\_\_\_\_

Make Outdoor Living *MORE FUN!*



From  
\$6.75

- SMART, NEW STYLING!
- ALL POPULAR SIZES!
- HOLDS COLD LONGER!
- EASY-TO-CLEAN, WHITE PORCELAIN INTERIORS!

**LITTLE BROWN  
JUGS & CHESTS.**

*Built To Last  
Season after Season!*

- Holds ice for days!
- Slip-in-tray, ice pick and opener.
- Outside drain, with "Can't Lose" cap.
- Rustproof, galvanized interiors.
- Sculptured, two-tone styling.
- 4 sizes to choose from.



From  
\$11.95

**HEMP & COMPANY, INC.**  
1957 Murray Street • Macomb, Ill.



**What!**

**Money Gone, Mom?**

Certainly not! Mom carried safe NCB Travelers Checks—got a prompt refund in full. Safe?—everywhere. Spendable?—yes, yes the world over. Famous for 50 years, they're backed by America's greatest world-wide bank. Cost only \$1 per \$100. Good until used. Buy them at your bank.



**FIRST NATIONAL CITY BANK TRAVELERS CHECKS**

Backed by the First National City Bank of New York  
Member Federal Deposit Insurance Corporation

Mention the National Geographic—It identifies you.



## EVER FEEL "A MILLION MILES FROM NOWHERE"?

It's just about how you feel when you're far from home and an accident happens. Your greatest need is the help of someone who knows what to do and how to do it.

If you are insured in a company of the America Fore Group, you can be sure that no matter where you may be, such a friend is nearby and ready to come to

your aid in case of need.

He will be one of America Fore's 40,000 agents or claims men located throughout the country—rendering the service and help you are entitled to expect when you are insured in a capital stock company with nation-wide facilities.

Remember, in the long run, the best insurance is the least expensive.



For the name of a nearby America Fore agent call Western Union by number, ask for Operator 25.



- ★ The Continental Insurance Company
- ★ Niagara Fire Insurance Company

- ★ Fidelity-Phenix Fire Insurance Company
- ★ The Fidelity and Casualty Company of New York



**Only TCA flies  
VISCOUNTS  
to Canada...**

**... And more people fly TCA to Canada than any other airline.**  
 Whether you're fishing for rainbow trout . . . or new markets in a thriving economy . . . come to Canada! Come TCA—from one of seven convenient "gateway cities"—to and through Canada. And remember . . . *only* TCA flies the world's most modern airliner—the turbo-prop Viscount to Canada.



**TRANS-CANADA AIR LINES**

See your local Travel Agent. Or contact TCA in: Boston, New York, Cleveland, Detroit/Windsor, Chicago, Seattle/Tacoma, Tampa/St. Petersburg, Los Angeles.



**NOVA  
SCOTIA**

not distant...  
but **DIFFERENT!**

What is your perfect holiday wish?  
 Adventure . . . romance . . . sport  
 . . . relaxation . . . history . . . sight-seeing?  
 Along Nova Scotia's inviting, seaside  
 highways you will find them all. The  
 quaint customs, spectacular scenery and  
 irresistible blend of picturesque fishing  
 coves, Old World towns and modern cities  
 will make your holiday complete . . .  
 and exciting!



**NOVA SCOTIA  
Travel Bureau**

P. O. Box 130, Halifax, Nova Scotia  
 Please send free literature to: NGA-57

Fast auto ferry, M. V. Blomrose; daily round trip between Bar Harbor, Maine, and Yarmouth, Nova Scotia.

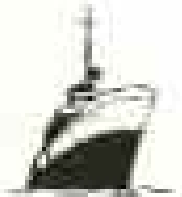

Free Award-winning, 36-page color booklet.



Name: .....  
 Address: .....  
 City: ..... State: .....  
 New York Office: 247 Park Ave., N. Y. 17, N. Y.



## Where else do the birds swim and the fish fly?

**On Southern California's seacoast** near Los Angeles, pelicans ride the long Pacific swells like animated cork, and big, blue flying fish take off like jet fighters. Strange conduct—but somehow it makes perfect sense here.

For in Southern California the unexpected is the expected . . . and strange sights are all around you.

North of Los Angeles, for instance, you can see great farms whose sole crop is flowers—thousands of acres of flowers grown like wheat for their seed.

At Santa Catalina Island you cruise over a great natural garden buried *under the ocean*—gaze down at seagoing goldfish flicking through smoken canyons.

In the High Sierra you find America's biggest trees, highest waterfalls and tallest mountains.

Within Los Angeles you discover a huge seaport, Hollywood's TV and movie studios, palm-fronted shops, ultramodern freeways, an old Spanish mission.

HOW ABOUT A CHANGE  
FOR A CHANGE?

# Southern California Vacation

Even our *climate* is unique: sunny, rainless days all summer long . . . nights so cool you sleep under blankets and carry a topcoat to Hollywood Bowl!

What other vacationland offers so much *variety*, so many unusual attractions . . . such a *change* from the usual? Truly a Southern California trip is the nic vacation experience. *Why not start planning it now?*

**FREE—OFFICIAL SIGHTSEEING MAP.** Big color map traces routes for sightseeing throughout Los Angeles County and all Southern California. Locates 645 sights visitors enjoy, including homes of 80 movie, TV and radio stars. Complete explanatory text. Mail coupon today!

**ALL-YEAR CLUB OF SOUTHERN CALIFORNIA.** This advertisement sponsored by the Los Angeles County Board of Supervisors for citizens of Glendale, Hollywood, Long Beach, Los Angeles, Pomona, Pompano, Santa Monica, Torrance, 162 other communities.

All-Year Club of Southern California, Dept. B-4  
628 West 6th Street, Los Angeles 17, California

Please send me free Color Sightseeing Map.

Name \_\_\_\_\_

Street \_\_\_\_\_

City \_\_\_\_\_

Zone \_\_\_\_\_

State \_\_\_\_\_

PLEASE PRINT NAME AND ADDRESS



**MORE AND  
MORE  
AMERICANS  
FLY  
AIR FRANCE**



*Because*

- The world's largest network flies 177,740 unduplicated route miles to 236 world-wide destinations.
- The airline that was first with international commercial flight has a 38-year record of dependability.
- Non-stop tourist and first class flights in Super "G" Constellations depart daily for Paris from New York. There is regular service from Boston, Chicago and Montreal.
- Air France is France aloft—offering the utmost in luxury, a famed cuisine.



*Enjoy Flight  
at its Finest  
—Fly Air France*



**AIR FRANCE**

**THE WORLD'S LARGEST AIRLINE  
WITH 177,740 UNDUPLICATED ROUTE MILES  
TO 236 CITIES IN 73 COUNTRIES**

**SEE YOUR TRAVEL AGENT OR AIR FRANCE**  
NORTH AMERICAN HEADQUARTERS  
683 Fifth Ave., New York 22, N. Y.  
OFFICES IN MAJOR CITIES

**FREE** to the  
**hard-of-hearing!**

REGULAR \$2.00 VALUE

Free one-year subscription  
to introduce the new magazine  
about hearing problems

The publishers of *Better Hearing Magazine* want you to discover the inspiration of reading how others have found happiness and success by solving their hearing problems. Invaluable to anyone who wears, or should wear, a hearing aid. (Many think they need a hearing aid and find they don't.) Already nearly a million readers. To receive free subscription, send name and address of hard-of-hearing person to: Editor, *Better Hearing Magazine*, 445 Park Avenue, Dept. 4R, New York 22, New York. No charge, no obligation to renew.

*Follow me to...*

**JACKSONVILLE  
FLORIDA**



Ancient ruins of Slave quarters  
on Ft. George Island

Make fascinating tours to nearby historic spots where the inspiring pages of the American story were first written. Places that were old when the timbers of the *Mayflower* still bore leaves. Add to this the sun and surf, spectator and participating sports, parks, playgrounds and gardens gay with exotic bloom and you have a combination found only in Jacksonville.

Send for free illustrated color folder "The City of Pleasant Memories"

FRANK A. WINCHELL

Tourist and Convention Bureau 267 Hogan St. Jacksonville, Fla.

NAME \_\_\_\_\_ ADDRESS \_\_\_\_\_

CITY \_\_\_\_\_ STATE \_\_\_\_\_



# LINCOLN

UNMISTAKABLY . . . THE FINEST IN THE FINE CAR FIELD



LINCOLN PREMIERE CONVERTIBLE

COAT BY VERA MAYWELL

No other car is so Lincoln long . . .  
Lincoln low . . . and Lincoln lovely !

*Here is the longest, most longed-for Lincoln ever! One look at its fresh, clean-lined styling and you can see why more and more fine car buyers are becoming Lincoln owners.*

Along the whole lovely length of Lincoln, there's a fresh, new kind of fine car beauty.

Exclusively Lincoln's, this beauty is expressed in long, low, distinctively new body lines that meet and merge in a clean sweep of steel. As a totally new *concept* of styling, it will shape fine car design for years to come.

Inside, you're in a whole new world of fine car

fashion and convenience. You can *custom-design* your Lincoln interior—from fine fabrics and soft, soft leathers. And then—*everything you touch turns to power!* . . . even the window vents and door locks can be operated electrically.

Finally, and most important of all, you find that Lincoln's extraordinary beauty is matched by superlative *driving*. With every mile, you discover more reasons why Lincoln is called the most *effortless* driving fine car ever built.

By all means, drive Lincoln *soon*. It's winning longing looks . . . and more and more fine car owners . . . everywhere it goes.

LINCOLN DIVISION, FORD MOTOR COMPANY



**This 196-Page  
FREE  
VACATION GUIDE  
TO NEW YORK STATE**

... offers a thrilling preview of what your 1957 vacation can be ... helps you plan your holiday to make the most of every exciting hour!

Magnificently illustrated with scores of full-color photographs, drawings and maps. Gives complete data on the Empire State's 15 famous Vacation Regions ... including 550 different communities and over 1,000 individual attractions. Lists types of accommodations, rates, sports and recreational facilities, sources of additional information.

The most complete state guidebook ever assembled—fully revised for 1957.

**MAIL THIS COUPON TODAY!**

New York State Department of Commerce  
Room 180, 112 State Street, Albany 7, New York

Send "New York State Vacationlands." I am interested in:  
A ( ) resort hotel, B ( ) city hotel, C ( ) bungalow colony,  
D ( ) tourist home, E ( ) summer cottage, F ( ) campsite,  
G ( ) children's camp, H ( ) dude ranch, I ( ) motel.  
I would like information from areas checked:

- |  |   |   |
|--|---|---|
| 1 <input type="checkbox"/> Adirondacks               | 6 <input type="checkbox"/> Finger Lakes         | 11 <input type="checkbox"/> Hudson-Tadousac     |
| 2 <input type="checkbox"/> New York City             | 7 <input type="checkbox"/> Saratoga-Lake George | 12 <input type="checkbox"/> Genesee Region      |
| 3 <input type="checkbox"/> Catskills                 | 8 <input type="checkbox"/> Long Island          | 13 <input type="checkbox"/> Chautauque-Allegany |
| 4 <input type="checkbox"/> 1000 Islands-St. Lawrence | 9 <input type="checkbox"/> Mohawk Valley        | 14 <input type="checkbox"/> Capital District    |
| 5 <input type="checkbox"/> Niagara-Frontier          | 10 <input type="checkbox"/> Central New York    | 15 <input type="checkbox"/> Southern Tier       |

Name \_\_\_\_\_  
Address \_\_\_\_\_ (PLEASE PRINT)  
City \_\_\_\_\_ Zone \_\_\_\_\_ State \_\_\_\_\_



**ON THE  
*Colorado Eagle***

From wagon trail to modern rail ... the lure of the Rockies has been irresistible! Today, Colorado means vacation variety for the *entire* family.

Board MO-PAC's streamlined, air-conditioned COLORADO EAGLE in St. Louis and wake up next morning in the mountains. Trains leave daily.



*Family Fare Plan!*  
LEAVE ANY MONDAY, TUESDAY,  
WEDNESDAY OR THURSDAY  
... and save  
up to 1/3 the cost!

Mrs. R. J. McDERMOTT  
General Passenger Traffic Manager  
1001 Missouri Pacific Building, St. Louis 3, Missouri

Please send folder that will help plan a low-cost trip to Colorado via MISSOURI PACIFIC.

(If student, please show grade ...) Also send folders checked below:

- MEXICO       HOT SPRINGS

Name \_\_\_\_\_  
Address \_\_\_\_\_  
City \_\_\_\_\_ Zone \_\_\_\_\_ State \_\_\_\_\_





## Complexion care for apples

Bigger and better fruit is yours

...with good looks that are more than skin deep

Apples, peaches, and cherries all taste best when they look best. But even before the first bud appears, fruits are constantly exposed to attack from plant diseases that can stunt growth and leave ugly blemishes on the surface.

**This battle with scab** is now being won with a remarkable liquid chemical called CRAC Glyodin. By preventing fungus growth, this highly protective spray improves the overall health of the trees and stimulates the natural glowing color of the fruit.

**Farmers—and home gardeners, too—** use other agricultural chemicals developed by the scientists of Union Carbide. For example, weed killers which cut down hand weeding on the

farm and around the home . . . and a repellent which helps increase milk and beef production by keeping livestock free from flies.

**These unique chemicals** were created by research and proved in exhaustive field tests. Union Carbide is now developing still more products to bring better foods to your table.

**FREE:** Learn how Union Carbide products and research help satisfy basic human needs. Write for "Products and Processes" booklet D.

**UNION CARBIDE**  
AND CARBON CORPORATION

30 EAST 42ND STREET  NEW YORK 17, N. Y.  
In Canada: UNION CARBIDE CANADA LIMITED, Toronto

UCC's Trade-marked Products include

CRAC Agricultural Chemicals

PREST-O-LITE Acetylene

EVEREADY Flashlights & Batteries

ELECTROBILT Alloys and Metals

SYNTHETIC ORGANIC CHEMICALS

LINDE Oxygen

PRESTONE Auto-Floors

HAYNES STELLITE Alloys

Dynal Textile Fibers

BAKELITE, VINYLITE, and KRONE Plastics

PHYOFAX Gas

NATIONAL Carbons

UNION Calcium Carbide

UNION CARBIDE Silicones

on your way to or from

# Los Angeles

go Union Pacific

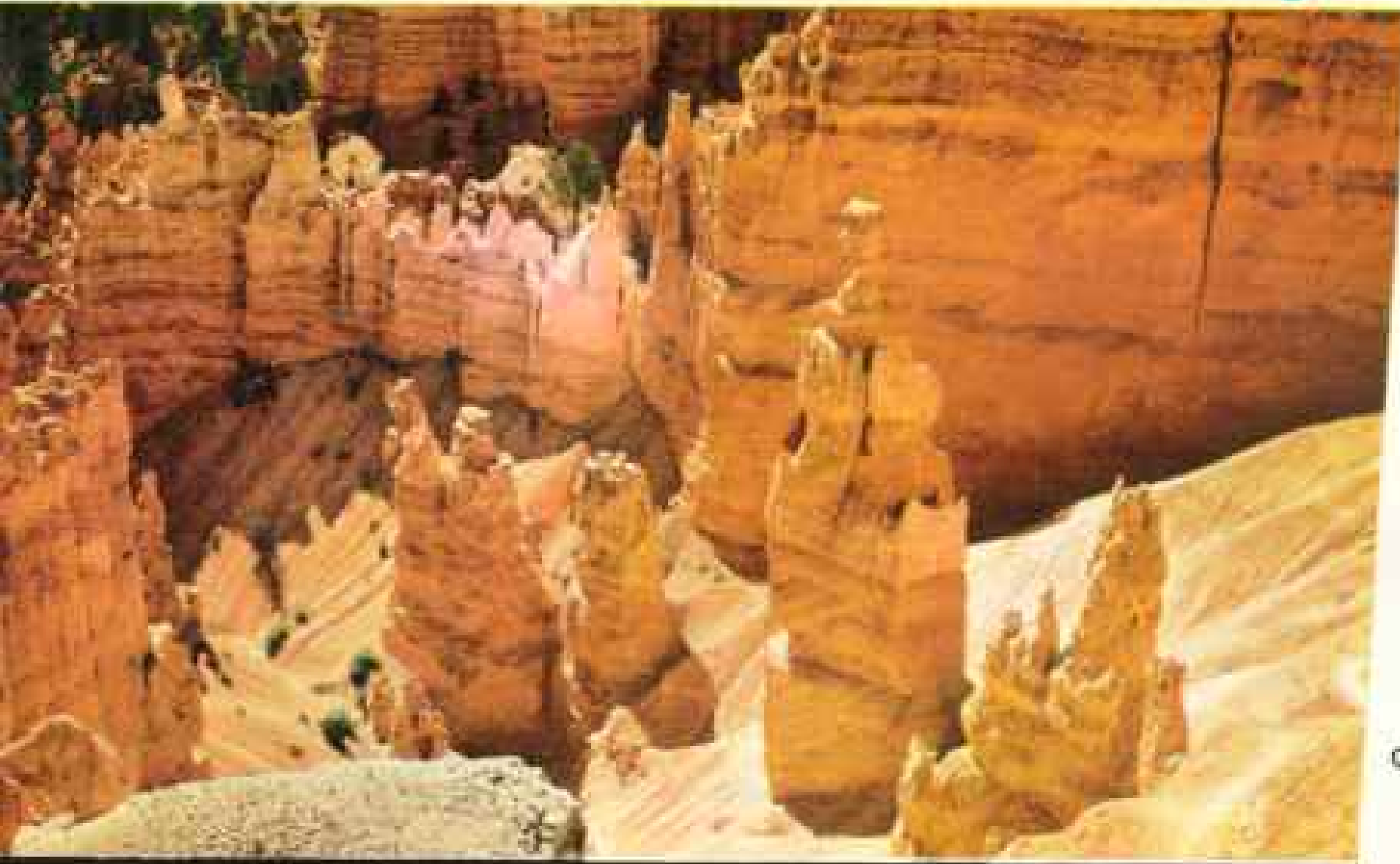

Above is a view of the fantastic formations in Bryce Canyon.



and stop over to see these **3** NATIONAL PARKS...  
*at no additional rail fare!*

The colorful and exciting beauty of these amazing National Parks annually attracts and thrills thousands of visitors.

Fortunately, it is possible to see them as a stopover on your way to or from Los Angeles when you go by Union Pacific.

A comfortable motor bus meets your train at Cedar City, Utah, and transports you through a world of

sight-seeing adventure. Your overnight accommodations in the Parks are completely modern and meals are excellent.

So why not take advantage of this unusual travel bargain? Even a short stay in this marvelous scenic region will greatly enhance the enjoyment of your trip. Ask to be routed by "U.P.," traveling to or from Los Angeles.

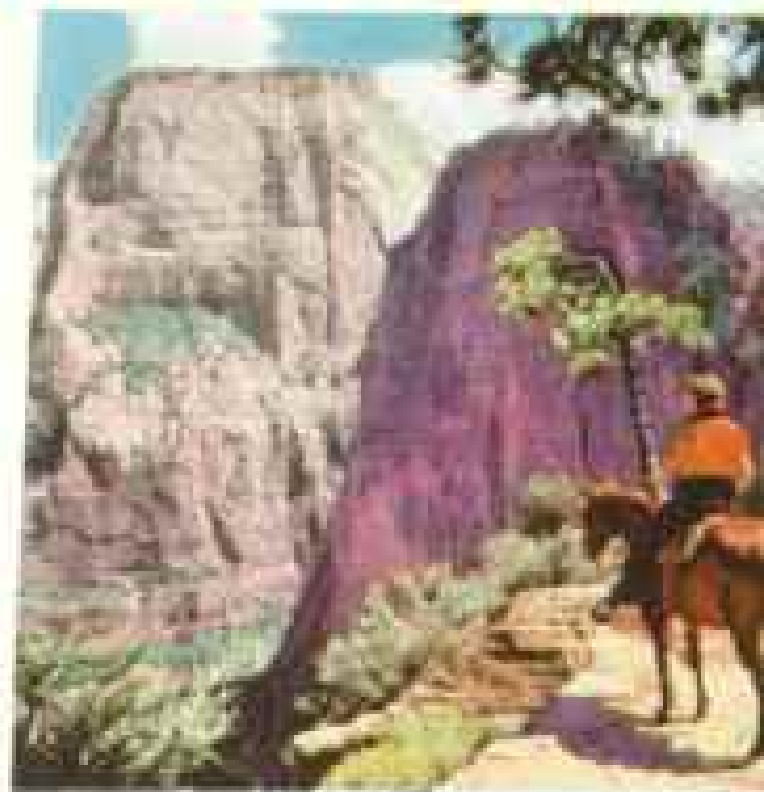

(Above) The stone towers of Zion National Park form a cathedral of beauty.

(Below) Overwhelming in size, dramatic in color, Grand Canyon is magnificent.



*By all means, take your camera. Mail coupon, requesting our "Utah-Arizona National Parks" booklet. It includes suggestions on how to obtain the best color photo results in the Parks area.*



Union Pacific Railroad, Room 767, Omaha 2, Nebr.  
 Please send free So. Utah-Arizona booklet.

Name \_\_\_\_\_

Address \_\_\_\_\_

City \_\_\_\_\_ Zone \_\_\_\_\_ State \_\_\_\_\_

Phone \_\_\_\_\_

Also send leaflets: Family Plan  All-Expense Tours



# Never Before!

such superb air conditioning  
for your entire home at such low cost!

**NEWEST!**  
from **Amana**  
CENTRAL-SYSTEM  
AIR CONDITIONING  
EVERYONE CAN AFFORD!

When summer heat and humidity hit—don't be without the pleasure and comfort of a truly air-conditioned home. Especially when you can have amazingly versatile Amana Central-System Air Conditioning at such low cost!

**Easiest Of All To Install!** New Amana Central-System Air Conditioning fits easily, conveniently in attic, basement, utility room, crawl space—practically *anywhere!*

**Completely Air Cooled!** Amana Central-System completely eliminates costly plumbing—extra water cost—troublesome permits. Often new Amana Central-System Air Conditioning ties in to your existing furnace duct-work. Or, order easy-to-install pre-fabricated duct.

**Temperature Engineered!** As temperature rises, Amana cooling efficiency actually increases to compensate. Your Amana works even better at peak heat!

**Now Is The Time To Install!** Put in your Amana Central-System Air Conditioning *now*—before demand for skilled installation crews raises rates and installation costs.

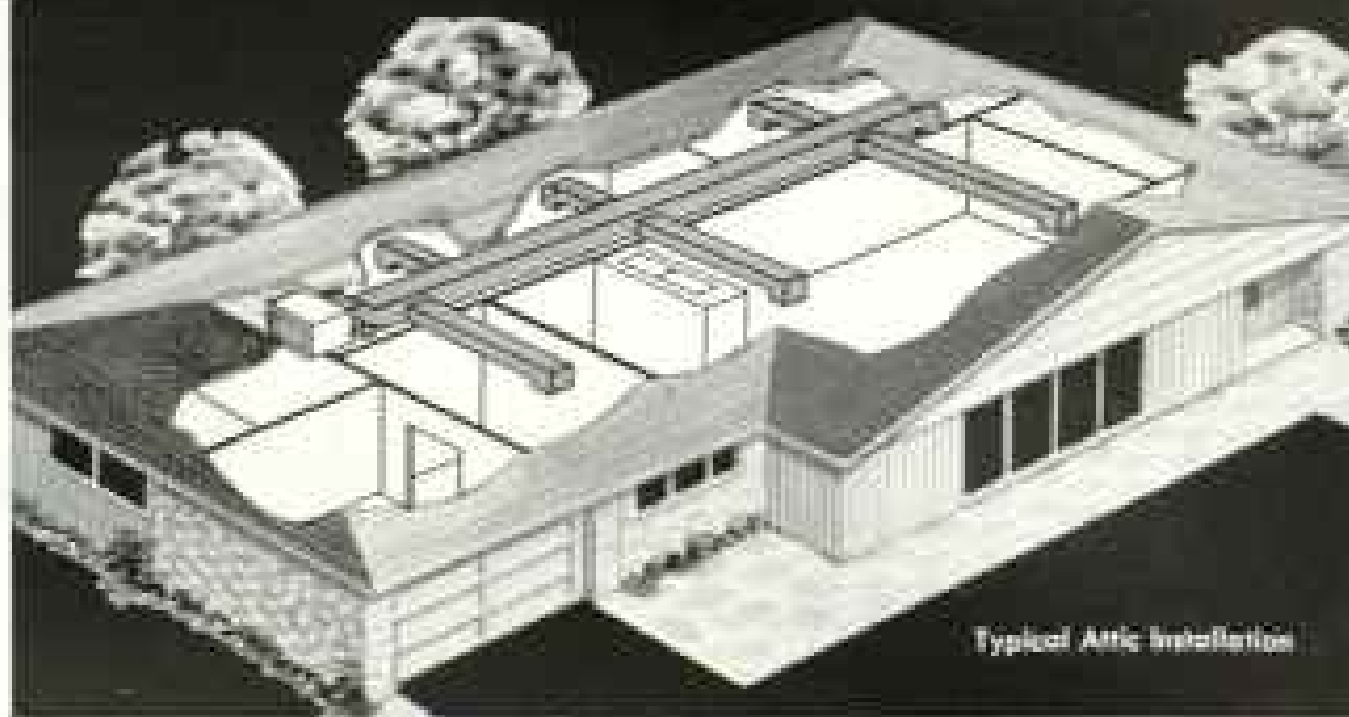

Typical Attic Installation

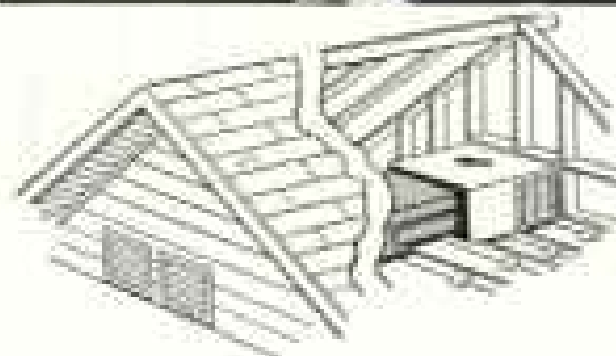

**Attic Installation.** Ideal for saving valuable living space. And, Amana Central-System ventilates attic while it cools.

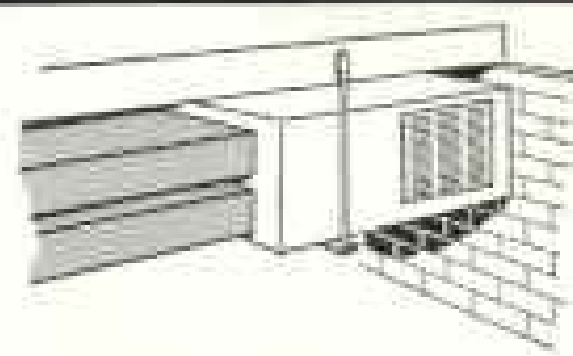

**Basements.** Choose from many installations. Amana unit needs little floor space. Or suspends from ceiling!

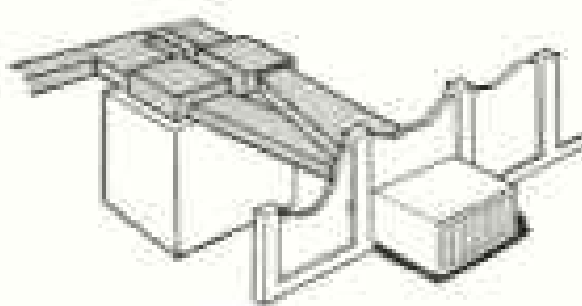

**Crawl space installation.** Partly mounted outside. Ducts run under floor—carry cool air to all the rooms.

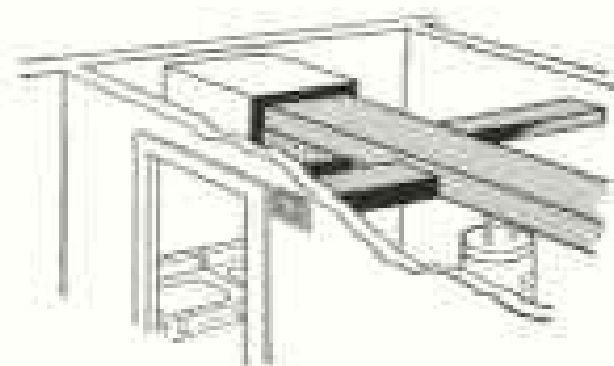

**Utility rooms, or large closets.** Often make ideal locations for the new Amana Central-System air conditioning.



Producers of World-Famous Amana Freezers  
Freezer-Plus-Refrigerators • Built-In Freezers and Refrigerators  
Room Air Conditioners • Central-System Air Conditioning  
Deepfreezer® Chest Freezers

AMANA REFRIGERATION, INC., AMANA 22, IOWA  
The words Amana and Deepfreeze are trademarks. Reg. U.S. Pat. Off.

**Planning On Building?**

Insure the resale value of your new home—plus your own comfort and pleasure. Install Amana Central-System Air Conditioning. You assure yourself of a cleaner, healthier, happier home!

Available on FHA Title One Loans — or an Easy Budget Pay Plan from your local contractor! For complete information mail this coupon today!

Amana Refrigeration, Inc.  
Amana 22, Iowa

Please mail me complete information on how new Amana Central-System Air Conditioning will add greater comfort and pleasure to my home at low cost.

Name \_\_\_\_\_

Address \_\_\_\_\_

City \_\_\_\_\_ Zone \_\_\_\_\_ State \_\_\_\_\_

# MILLIONS OF PEOPLE

The Sun Life of Canada, in 86 years of public service, has provided life insurance protection for millions of people.

In 1956 the Company paid to policyholders and beneficiaries an amount exceeding \$137 million, bringing to \$5,140,000,000 total benefits paid out since the first Sun Life policy was issued.

One of the great life insurance companies of the world, the Sun Life of Canada today serves its policyholders with branch offices and representatives from coast to coast across North America and in 25 other countries around the globe.

SUN LIFE ASSURANCE  
COMPANY OF CANADA

*Over seven billion dollars of life  
insurance in force.*



# FREE!

PROVINCE OF  
**NEW BRUNSWICK**  
CANADA

## Holiday Kit

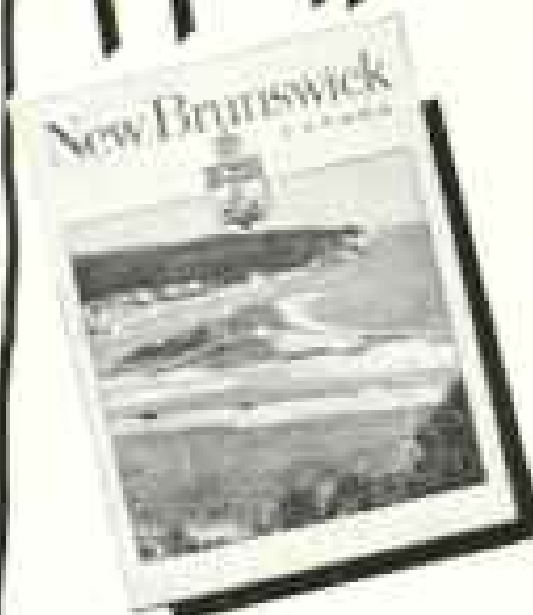

Enjoy an "arm-chair" tour of New Brunswick! The Holiday Kit includes a new fully illustrated tour book, complete list of accommodations and a road map.



Write today—and plan now for an exciting holiday in this picturesque Canadian province by the sea.

See Canada's *Picture Province* this summer!

New Brunswick Travel Bureau      NG2-57  
Fredericton, New Brunswick, Canada  
Please send a Province of New Brunswick Holiday Kit to:

Name.....

Street.....

City/Town..... State.....

From a radio as  
small as your hand  
...to one as big  
as the world

*Zenith extra quality means finer performance*



The Zenith Royal "500" Transistor Pocket Radio is a tiny, tubeless radio so powerful it performs where others fail. 7 transistors (not just 4 or 5) give it far greater sensitivity and volume. Plays in trains, boats, planes, and cars. Earphone attachment permits private listening. See the Royal "500". Hear it . . . you'll want it, too. It defies comparison. \$75.00\*

The incomparable Zenith **TRANS-OCEANIC®** Portable Short Wave Radio is powered to tune in the world. A boon to foreign language students. International short wave, standard broadcast, marine, weather, and amateur short wave bands. Treated against humidity. Operates in ships, planes, trains, steel buildings . . . on AC, DC or long-life batteries. The TRANS-OCEANIC Radio's list of owners reads like an international "Who's Who!" \$139.95\* to \$159.95\*



QUALITY  
BY  
**Zenith**  
*The Royalty of Radio*

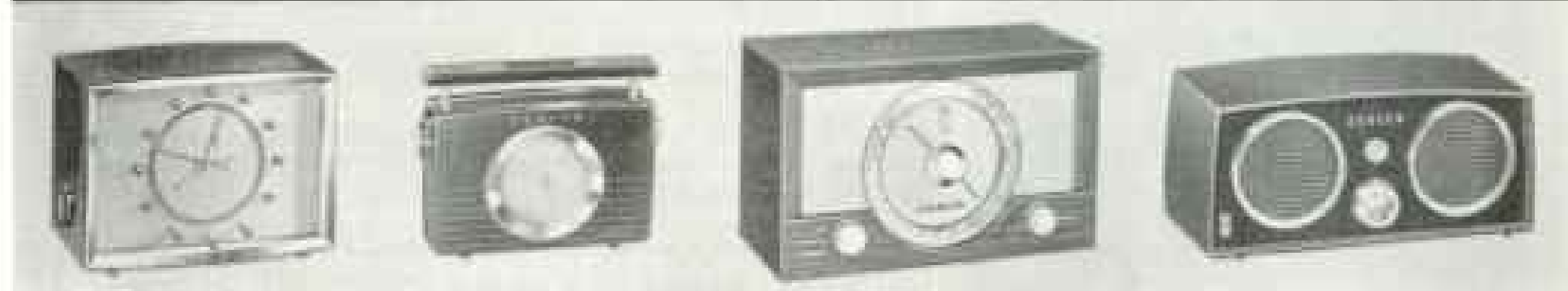

**Zenith Custom Clock Radio.** A powerful long-distance radio with big, rich Zenith tone, completely hidden behind the face of a clock! Automatically turns appliances on and off, wakes you to music. \$49.95\*

**"Royal 800" Transistor Portable.** 7 transistors and built-in Wavemagnet® Antenna increase signal reception up to 25%! Plays even where other portables fail. Most glorious tone in portable radio. \$87.50\*

**3-Speaker FM/AM High Fidelity Radio** (2 "tweeters", 1 Alnico 5 speaker) engineered by Zenith, world leader in FM. Automatic "station lock" for virtually drift-free tuning. Wavemagnet® Antenna, phone jack. \$109.95\*

**2-Speaker Console Tone.** 2 big Zenith quality Alnico 5 speakers bring you long distance AM radio at its rich, vibrant best. Zenith Wavemagnet® Antenna, automatic volume control, phone jack. \$34.95\*

\*MANUFACTURER'S SUGGESTED RETAIL PRICE. SLIGHTLY LOWER IN THE FAR WEST AND SOUTH.

Zenith in Styling! Zenith in Sound!

ZENITH RADIO CORPORATION, CHICAGO 39, ILLINOIS



Backed by 38 years of leadership in radio sets exclusively. Also makers of fine Hearing Aids.

Mention the National Geographic—It identifies you

# CONTAFLEX

## This way to Great Pictures



World Famous  
Zeiss Ikon Cameras  
are precision-made  
In West Germany

For every photographic need, here is a line of four great 35mm cameras. The two newly developed models (III and IV) have bayonet-mounted front lenses interchangeable with either *wide angle* or *telephoto* lens components.

All Contaflex cameras are single lens eye-level reflex. They have ground glass and split image focusing, double-bright and clear, seeing through the famous Carl Zeiss f/2.8 lens.

At leading dealers, see the advanced Contaflex line, from \$153. Send for booklet CN18.



**CARL ZEISS INC., 485 FIFTH AVE. N.Y.**



### GREATEST TRAVEL BARGAIN IN THE U. S.

*More Scenery — More History — More Sports — More Fun . . .  
In Pennsylvania, State of a 1001 Vacation pleasures*

From Philadelphia, "birthplace of American freedom" to Lake Erie's sandy beaches . . . there's a thrilling panorama of Nature's wonders and superb vacation facilities waiting for you in historic Pennsylvania.

Truly, here is America's greatest travel bargain . . . for in no other state can you find Pennsylvania's matchless combination of glorious past and fun-filled present.

**FREE!** 28-pages, dozens of breathtaking full color photographs . . . an invaluable guide to the recreation, relaxation and inspiration you'll find in hospitable Pennsylvania.

PENNSYLVANIA DEPARTMENT OF COMMERCE  
625 State Capitol Bldg., Harrisburg, Pennsylvania.

Send me a free copy of your 28-page full color brochure  
"More Vacation Fun for Everyone in Pennsylvania."

Name \_\_\_\_\_  
Address \_\_\_\_\_  
City \_\_\_\_\_  
Zone \_\_\_\_\_ State \_\_\_\_\_

*Why wait  
to be in Italy?*



*Step aboard an Italian Line ship!*



The charm of an Italian smile . . . the beauty of Italian art . . . the warmth of Italian hospitality greet you as you step aboard a luxurious Italian Line ship. Delightful dishes, reminiscent of the famed restaurants of Rome, grace your table. And the Sunny Southern Route gives you a foretaste of the Riviera, the blue skies of Sorrento. See your Travel Agent or Italian Line, Battery Park Bldg., 24 State Street, New York 4, N. Y. Tel.: DIgby 4-0800.

***Italian Line***

CRISTOFORO COLOMBO • GIULIO CESARE • AUGUSTUS • VULCANIA • SATURNIA

Feel the Spirit  
of America!



## VISIT WASHINGTON

— Shrine of  
American Patriotism

A wealth of breath-taking beauty, historic landmarks and shrines, marvelous exhibits, inspiring memorials—*this is Washington!*

See your Nation's Capital this year.

Go the Care-Free Way... by Baltimore & Ohio!

It's the extra courtesy, the relaxing comfort that makes B&O travel so outstanding. Make your trip more pleasant from the outset—go B&O!

### TOURS and SPECIAL FARES

Talk with a B&O representative or your local travel agent—or write to us for information on Washington sightseeing, hours and savings on round-trip fares. Special rates for organized groups. Make your plans now!



### FREE! 52-PAGE PICTORIAL GUIDE TO WASHINGTON

Where to go! What to see! It's all in this descriptive book. 60 illustrations, street map. Handy pocket size. IT'S FREE. FILL IN AND MAIL COUPON TODAY!



J. F. Wilmington, Gen. Pass. Trcl. Mgr.  
Baltimore & Ohio Railroad (Dept. AAT) Baltimore 1, Md.

Please print plainly, without charge, a copy of your  
"Pictorial Travel Guide to Washington"

Name \_\_\_\_\_

Address \_\_\_\_\_

City \_\_\_\_\_ Zone \_\_\_\_\_ State \_\_\_\_\_

If you want information on a trip to Washington, check here

## BALTIMORE & OHIO RAILROAD

**WORLD'S TOPS**  
in a spin box!

the **My Spin'n' Buddy** No. 350 E

DESIGNED ESPECIALLY FOR SPIN FISHING

Drawn from one piece of sturdy, lightweight pebble grain embossed aluminum. Can't rust or leak. 30 bait compartments keep plugs and spinners where they belong—at your finger tips.

See them at your favorite sporting goods dealer.

**FALLS CITY DIVISION** World's Largest  
**Stratton & Terstegge Co., Inc.** Manufacturers of  
P. O. Box 1859, Louisville, Ky. Tackle Boxes and  
Minnow Buckets

this year visit  
**IDAHO**

THERE'S A LOT MORE TO SEE AND DO IN IDAHO!

There's exciting fun for every member of the family in Idaho. You'll find a wonderful variety of outdoor vacation activities offered no other place in America. There's real western adventure in Idaho.

The place to go is IDAHO

SEND FOR THE FULL COLOR BROCHURE ON PLACES TO GO IN IDAHO

SALMON RIVER SLIM, BOISE, IDAHO

Name \_\_\_\_\_

Street No. \_\_\_\_\_

City \_\_\_\_\_ Zone \_\_\_\_\_ State \_\_\_\_\_

IDAHO STATE DEPARTMENT OF COMMERCE & DEVELOPMENT



...you'll remember  
**OREGON!**



*Along the Pacific* for 400 miles is an Oregon maritime playland of smooth beaches, rocky headlands, quiet bays, fishing villages and busy seaports. This viewpoint is at Cape Sebastian in Southwestern Oregon.

*Interesting Fossil Beds* are found in Eastern Oregon where this rock formation, The Cathedral, is a landmark. It's in the Thomas Condon-John Day State Park, one of 200 parks set aside for you in Oregon.



*There's So Much to See* and do in Oregon that your vacation days will pass all too quickly here — but they'll be happy days . . . days you'll treasure forever. Your whole family will have fun. There's wide appeal in areas pictured on this page, the seacoast and plateau country. For other needs and moods, Oregon offers shining mountains; deep evergreen forests; colorful wildflowers, and sparkling lakes, rivers and waterfalls. Against these and other scenic backdrops holidays take on added allure. So, make plans now to stay in Oregon as long as possible. Come soon.



See All of  
**Oregon**  
by driving scenic highways



MAIL THIS COUPON  
NOW FOR YOUR COPY  
OF OREGON'S COLOR  
BOOKLET. IT'S FREE!

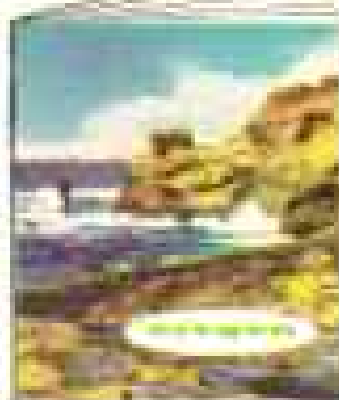

TRAVEL INFORMATION, Room 67, Highway Dept., Salem, Oregon  
Please send me free booklet, "Oregon, Cool Green Vacationland."

Name \_\_\_\_\_  
Address \_\_\_\_\_  
City \_\_\_\_\_  
Zone \_\_\_\_\_ State \_\_\_\_\_



Pardon the intrusion...but if you're an engineer, Douglas needs you!

At Douglas, you'll work on more civilian and military projects than you can cram into two billion dollars!

- on nine separate missile projects!
- on the exciting DC-8 jet transport!

We're engineers, not bankers or salesmen. And we'd like you to work for us — in California, Arizona, Oklahoma, North Carolina, or — you name it, we're probably there.

Please write for complete information to:

C. C. LaVENE  
DOUGLAS AIRCRAFT COMPANY  
BOX 620-E  
SANTA MONICA, CALIF.

Go further with  
**DOUGLAS**



Mention the National Geographic — It identifies you

## Gay Western Vacations



on the Super Dome

**OLYMPIAN**  
*Hiawatha*



See all the scenic Northwest route from the full-length Super Dome. Pullmans with Sky-top Lounge, Touralux cars offering lowest cost sleeper travel to and from the Northwest, leg rest coaches, diner and Cafe Lounge. Round trip coach fares in western territory little over 2¢ a mile—much lower than airline fares.

### FREE PLANNING HELP

- ① **PACIFIC NORTHWEST**—Coulee Dam; Seattle-Tacoma with Puget Sound, Mt. Rainier, Olympic Peninsula; Victoria and Vancouver in British Columbia.
- ② **YELLOWSTONE PARK**—via Gallatin Gateway, Old Faithful Geyser, Grand Canyon. Also Montana Rockies.
- ③ **DUDE RANCHES**—in the wide open spaces.
- ④ **PACIFIC NORTHWEST**—Yellowstone.
- ⑤ **COLORADO ROCKIES**—Salt Lake City, Mormon capital—Yellowstone—Idaho—Montana.
- ⑥ **CALIFORNIA**—Oregon—Washington—see the Pacific Coast and see it all.
- ⑦ **CANADIAN ROCKIES**—Victoria-Vancouver—San Juan Islands—Pacific Northwest.
- ⑧ **ALASKA**—by the Inside Passage.
- ⑨ **ESCORTED TOURS**—wide variety.

H. Sengstacken, The Milwaukee Road  
706 Union Station, Chicago 6, Ill.

I am interested in vacations 1 2 3 4 5 6 7 8 9 (circle choices). Please send free vacation planning literature.

Name \_\_\_\_\_

Address \_\_\_\_\_

City \_\_\_\_\_ Zone \_\_\_\_\_ State \_\_\_\_\_

**THE MILWAUKEE ROAD**



## “O senhor quer a Salada de Palmito?”

There's nothing like salt air and brilliant sunshine to give you a marvelous appetite.

And you'll feel even hungrier when you review the flotilla of delicacies our famous chefs have prepared for you at our open air buffet.

Of course, there's always a South American specialty like Brazilian Heart of Palm Salad to tempt an adventurous appetite.

If you have spent the morning in our spacious deck pool, you'll want to tear into "Bife de Cordeiro Grelhado" or piping hot roast beef.

Along with sports and parties, you'll get a solid, bone-deep rest. You'll spend joyous days and nights ashore in exotic ports... make new friends... have the time of your life!

See your travel agent today.

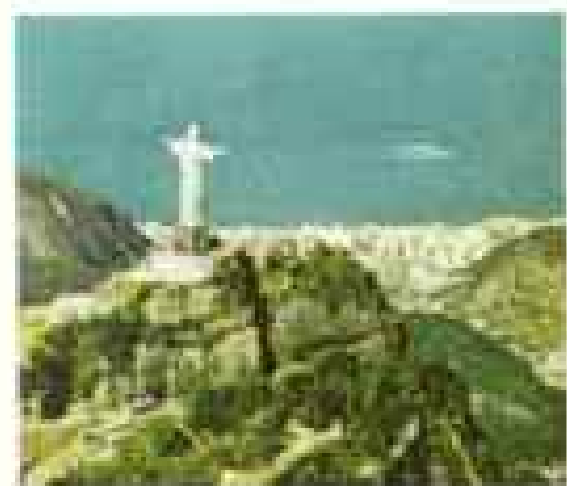

Statue of Christ atop Corcovado overlooks Rio.



Old buildings near modern shops in Buenos Aires.

MOOREMACK TO SOUTH AMERICA

**MOORE-**  
**McCORMACK**  
*Liners*



Five Broadway,  
New York 4, N. Y.

38-day cruises to South America via the S.S. ARGENTINA... S.S. BRAZIL. Rates from \$1,110. These 33,000-ton liners sail every three weeks from New York to: TRINIDAD • BARBADOS • BAHIA • RIO DE JANEIRO • SANTOS (São Paulo) • MONTEVIDEO • BUENOS AIRES



You should see Du Mont if only to establish a standard by which television may be judged. See Du Mont, television's finest instruments. Find out *all* that television offers. Don't settle for anything less than a Du Mont!



**DU MONT  
BELVIDERE**

21" overall diagonal; 262 sq.-in. viewable area. Mahogany Grain or Lined Oak Grain finish.

For free illustrated Du Mont Buying Guide, write Allen B. Du Mont Laboratories, Inc., Dept. NG4 Receiver Division, 35 Market St., East Paterson, N. J.

MAIL  
THIS  
COUPON

**WRITE  
RIGHT  
NOW!**

... for your copy of Miami's Big, Beautiful, Informative **NEW** brochure. Write to:

"INVITATION TO MIAMI" • Dept. 4  
320 N. E. 5th St., Miami, Florida

NAME.....

ADDRESS.....

CITY.....STATE.....

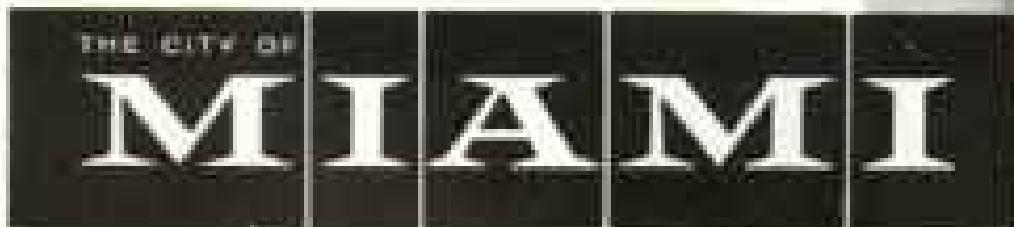

Young or old... whatever your desires—Miami spells vacation magic to millions... year-round. And Miami can spell **VACATION MAGIC** for YOU!



To make your playtime a gaytime... magical Miami beckons you to her golden shores! Find your place in the sun on cool, breeze-swept beaches. Keep through fun-filled days of your favorite sport—swimming, boating, fishing, golf, tennis. Three AAA baseball and a host of other spectator sports. Be a part of the excitement of a bustling young metropolis. Relax in the carefree, come-day go-day atmosphere of the tropics.

**Come To The Spring Festival!**

April 27-May 15

The sparkling highlight of the year! Colorful, spectacular musical attractions—pageants, sports, concerts, dances. Informative and fascinating industrial exhibits. Mirth and melody, fun and festivity! *Come!*



## Charting a safer course against **CANCER**...

Just as the pilots of ships are helped to chart safer courses by heeding signals, so, too, have many people been made safe by recognizing warning signals of possible cancer and taking proper action.

In fact, thousands of people are alive and well today because they knew cancer's warning signs and were treated in time. For your own protection, you should know the danger signals which are listed here.

Remember, however, that these signals do not always indicate cancer. Rather, they may just be signs that something is wrong—and that you should see your doctor promptly. If cancer is found, precious-time will be gained by starting treatment immediately.

Even if no symptoms occur, it is important to have periodic health examinations, particularly if you are 35 years of age or older. Studies show that about 95 percent of all cancers are found in people over 35.

If people would act promptly when a danger signal is noticed . . . if apparently well people would have their doctors examine them regularly . . . the American Cancer Society believes that the annual number of cancer cases saved could be increased 50% with weapons now at hand.

### Cancer's Seven Warning Signals

1. Any sore that does not heal.
2. A lump or thickening in the breast or elsewhere.
3. Unusual bleeding or discharge.
4. Any change in a wart or mole.
5. Persistent indigestion or difficulty in swallowing.
6. Persistent hoarseness or cough.
7. Any change in normal bowel habits.

Medical science is now pushing a total attack against cancer . . . and progress is being made in both cancer diagnosis and treatment. Meantime, you have a responsibility to yourself and others to:

1. Have periodic health examinations
2. Know cancer's early danger signals
3. Get prompt medical care at once if any danger signal appears

For more information on cancer, send for Metropolitan's free booklet, "*What You Should Know About Cancer*."

© COPYRIGHT 1987—METROPOLITAN LIFE INSURANCE COMPANY

**Metropolitan Life**  
**Insurance Company**  
(A MUTUAL COMPANY)

1 MADISON AVENUE, NEW YORK 10, N. Y.



Metropolitan Life Insurance Company  
1 Madison Ave., New York 10, N. Y.

Please send me the free booklet, "*What You Should Know About Cancer*," 4-57-N.

Name \_\_\_\_\_

Street \_\_\_\_\_

City \_\_\_\_\_ State \_\_\_\_\_

# BOSTON TO NEW YORK

231 miles...on four blown-out tires!



**HERE WE GO!** We blew out all four tires with a knife. Now we're moving through Boston's Copley Square. This stop-and-start city driving is no tea

party for 4 blown-out tires. But the tough nylon "inner tires" take the punishment in stride... make us feel certain we'll reach New York safely.



**175 MILES OUT!** We're near the posted speed limit of 55. Are we worried? Not a bit! This double air chamber principle is backed by millions of miles of LifeGuard experience.

**231 MILES LATER!** We arrive in Times Square on those four blown-out Captive-Air Safety tires! No damage to the "inner tires"—no damage to the outer tires other than the knife cuts.

Goodyear's new nylon Captive-Air Safety tires made tire changes unnecessary. You, your wife and children can be virtually free from the danger of blowouts and punctures... the inconvenience of roadside tire changing.

The Captive-Air Safety tire, tested and proved in Detroit, is now standard and optional equipment on some of America's finest cars. See it this week. Goodyear, Akron 16, Ohio.

Here's how Captive-Air works:

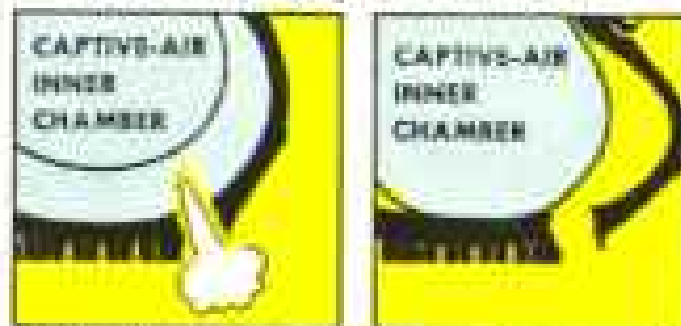

Left: Only the air in the outer chamber escapes when the Captive-Air tire is cut, torn or blown out.

Right: Reserve air in the built-in spare supports the car—lets it drive on for 100 miles or more.



**MORE PEOPLE RIDE ON GOODYEAR TIRES THAN ON ANY OTHER KIND!**

**Only Goodyear has CAPTIVE-AIR... the safety tire with the built-in spare!**



# GOODYEAR

Ask about our Lifetime Guarantee. No time limit!  
No mileage limit! No expiration date!

LifeGuard, Captive-Air, T.M.'s, The Goodyear Tire & Rubber Company, Akron, Ohio

*The talent of Jack Potter's brush visits a pleasant home overlooking famous Diamond Head.*



**When you come to Hawaii...** *here, too, you'll find the enjoyment of Coca-Cola is a welcomed social custom... just as it is in over 100 different countries. Wherever you are, have a Coke... enjoy the distinctive good taste that has made Coca-Cola the best-loved sparkling drink in all the world.*



**SIGN OF GOOD TASTE**

Tourists at Fort McHenry National Monument, Md., see a replica of the flag which inspired our national anthem. It has 15 stars and 15 stripes.



## Fort McHenry—where 1100 men saved a city . . . and wrote a song

Over most places, the flag flies from sunrise to sunset, but at Fort McHenry in Baltimore it flies day and night. There's a reason for it.

Here, in 1814, 1100 gallant defenders were bombarded for 25 hours by the British fleet. At dawn the flag still flew...the attack was repulsed and the city was saved. It was then that Francis Scott Key, inspired by the American colors still flying, wrote "The Star-Spangled Banner."

Today, Fort McHenry, under the supervision of the National Park Service, offers visitors a fine example of 18th century military architecture. In its museums are interesting relics of the War of 1812, the Bowie Collection of Firearms and a collection of original flags. Within easy driving distance are many other sights worth seeing including Annapolis,

Civil War battlefields, famous universities, museums and the amazing Sherwood Gardens.

But the greatest sight is still the banner waving over the ramparts 24 hours a day—a tribute to the men who stayed on their feet and slugged it out in defense of liberty, and to the song they helped to write.

Americans have stood up and fought for freedom ever since. Maybe that's why we all get to our feet whenever "The Star-Spangled Banner" is played.

**FREE Tour Information** 

If you would like to visit Fort McHenry, or drive anywhere in the U.S.A., let us help plan your trip. Write: Tour Bureau, Sinclair Oil Corporation, 600 Fifth Avenue, New York 20, N. Y.—also ask for our colorful National Parks map.

**SINCLAIR SALUTES KEEP MARYLAND BEAUTIFUL, INC.**, a non-profit, volunteer service organization, for pioneering in the nationwide educational program to keep America's roadsides, parks, beaches and other public areas free from litter. Keep Maryland Beautiful, Inc., supported by local business and industry in cooperation with government and civic leaders, is an affiliate of Keep America Beautiful, Inc., the national public service organization for the preservation and improvement of America's scenic beauty.

**SINCLAIR**  
*A Great Name in Oil*

Another in Sinclair's American Conservation series



**A PERFECT MATCH...**

*Celeste*  
**STERLING by GORHAM**



Sandwich plate,  
 8".....\$17.50  
 9".....\$26.50  
 10".....\$35

Gifts in Celeste in  
 flat silver start at  
 less than .....\$5.00



Pair of candlesticks.....\$14.75



Pair compote tps (black plastic).....\$4.50  
 Pair of candlesticks.....\$14.75  
 Pair complete compotes\$19.25



Pair of candlesticks.....\$14.75  
 Pair of branches.....\$35  
 Pair complete candelabra...\$49.75

*Gorham* **STERLING**  
 America's Leading Silversmiths Since 1831

Look for the famous Gorham Seal on the under-  
 side of all sterling holloware. The seal is your  
 assurance of authentic design, distinctive quality  
 and traditionally superior craftsmanship.



484271-100/007 FEDERAL REG.—SUBJECT TO CHANGE WITHOUT NOTICE.

*Going to Europe?*

A new

**RENAULT**

delivered when you land, lets  
 you explore the Europe  
 most tourists  
 never see!



As little as \$300 to drive your own Renault 4-  
 passenger, 4-door sedan for 3 glorious months in  
 Europe, under Renault's Guaranteed Repurchase  
 Plan. 7 other models to choose from, including the  
 glamorous 1957 Dauphine. We eliminate all red  
 tape to give you a perfectly carefree vacation. After  
 trip, we guarantee to arrange repurchase at fixed  
 price in dollars. Or we'll ship car home for you.  
 Either way, it's Europe's best travel buy!

See Your Travel Agent or Write Dept. NG-4

**RENAULT OF FRANCE**

Direct Factory Branch: 425 Park Ave., New York 22  
 In Canada: 1427 Mountain St., Montreal 26, P. Q.

This year visit **UTAH**  
 The Center of Scenic America



Explore America's last great  
 frontier... enjoy your favorite  
 sports and hobbies... rest in the  
 mountains or play in the cities...  
 Utah is the crossroads of vacation  
 adventure. Stay a week... a month  
 ... or all summer, you'll find Utah  
 a fascinating and ideal vacation-  
 land.

Full-color book  
 of what to see  
 and where to  
 go. List of  
 special summer  
 events, Utah  
 Highway Map  
 including loca-  
 tion of scenic  
 attractions.



UTAH Tourist & Publicity Council  
 Dept. M-2, State Capitol  
 Salt Lake City, Utah

NAME.....  
 ADDRESS.....  
 CITY..... STATE.....

Mention the National Geographic—It identifies you.



Let yourself **GO**

on the INDEPENDENCE or  
CONSTITUTION to Europe!

YOU SHOULD have heard them singing *Happy Birthday* . . . all of them, from the girl out there on the rail of the pool, to the waiter who brought the cake.

The whole thing's typical of the friendly, relaxing spirit you'll find aboard these "Happy Ships" that swing south on the sparkling blue *Sunlane*, the mild-weather route to Europe.

Join us on the *Sunlane* to and from Europe. It's the nature-favored route between New York City and *Algeciras*, on the southern tip of Spain (special boat-train, "The Castilian," offers connections to and from Madrid) . . . *Cannes*, for the French Riviera and express connections to Paris . . . *Genoa*, for the Italian

Riviera and Central Europe . . . and *Naples*, for Rome, Capri, Sorrento and all of southern Italy and Sicily.

**SPECIAL CRUISES PLANNED FOR COMING YEAR**

1. *Sunlane Cruises* to Europe, from \$680 First Class, \$530 Cabin . . . 3-week round trip vacations, sailing from New York September through January.
2. *Popular 4 Aces'* 45-day round trip cruises to the Mediterranean, every fortnight, \$960 minimum.
3. *Sea-Air Cruises* to Europe (complete pre-packaged vacations, one way sea, one way air) . . . as low as \$698.
4. *The DeLuxe Cruise of 1958* . . . the *Constitution* to the entire Mediterranean . . . early February, 1958.

SEE YOUR TRAVEL AGENT OR

**AMERICAN EXPORT LINES**

38 BROADWAY, NEW YORK 6, N. Y.





Mark of a man who knows  
color-slide cameras

**THE NEW ARGUS C-44**

... only **\*99.50** (with 50mm lens.)

**A Lens Second to None** (Cintagon f:2.8) gives your pictures remarkable clarity and contrast.

**Bayonet-type Lens Mount** lets you switch to either of two equally-fine accessory lenses—the Wide-angle or the Telephoto (shown on camera)—with just a quick twist of the wrist.

**New Variable Power Viewfinder** accessory clips right on top of camera—gives you a separate viewfinder for each lens simply by rotating the knob.

**Lens-Coupled Rangefinder-Viewfinder** lets you compose and focus through just one window.



Saddle Leather Case \$10.  
100mm Telephoto Lens (shown on camera) \$59.50.  
35mm Wide-angle Lens \$56.50. Variable Power Viewfinder (shown on camera) \$14.50.

**argus**

Argus Cameras, Ann Arbor, Michigan  
Division of Sylvania Electric Products Inc.

WORLD'S NO. 1 NAME IN COLOR-SLIDE PHOTOGRAPHY

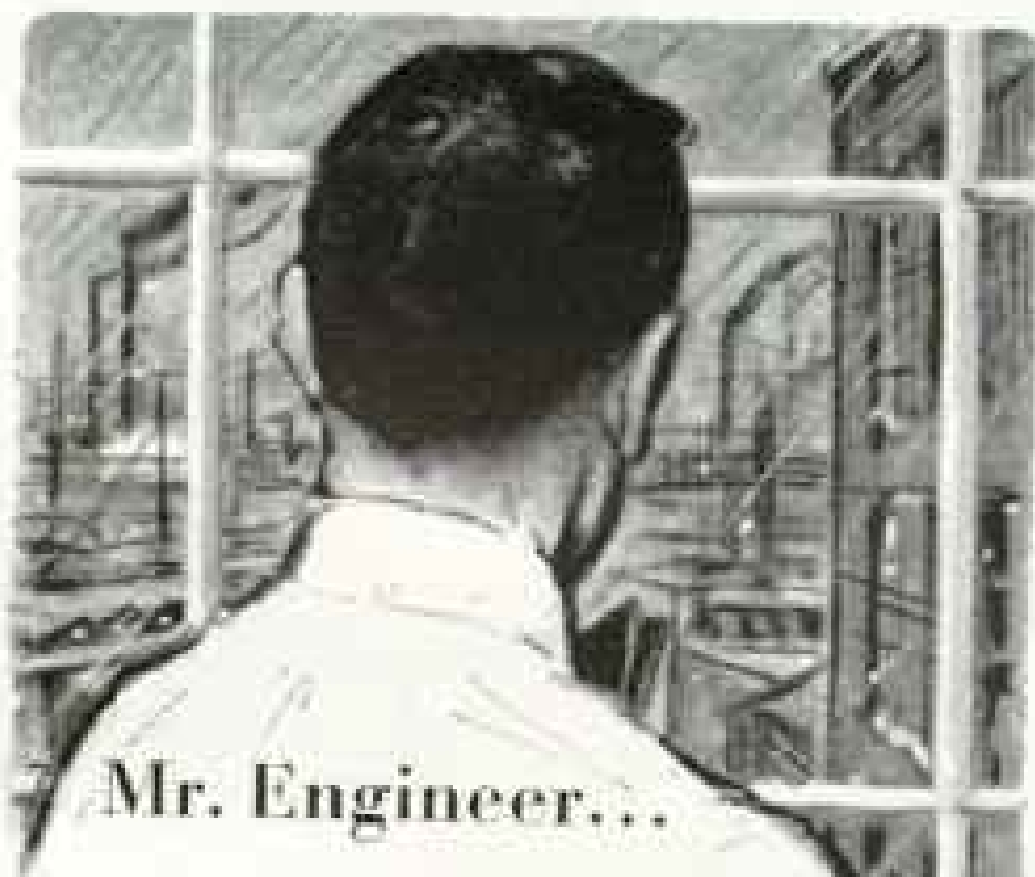

**Mr. Engineer...**

*Are you happy?*—If you're not satisfied where you are, you'll find limitless opportunities for success on the top-flight engineering team at Northrop Aircraft. You'll be happy with the salary, benefits and assignments. And you and your family will enjoy living in sunny Southern California. Why not do something about the move you've probably thought about many times? Write Vice President, Engineering, Northrop Aircraft, Inc., 1023 East Broadway, Hawthorne, California.



**NORTHROP**

BUILDERS OF THE FIRST INTERCONTINENTAL GUIDED MISSILE



**TENNESSEE**

*Glorious Vacationland*

**FOR THE WHOLE FAMILY**

**Mountains . . . Lakes . . . History** — Towering peaks, playful bear cubs, wildflowers, mountain villages, native handicrafts, folk music in the Great Smokies, America's favorite national park. Fishing, swimming, boating, water sports on 20 fabulous Great Lakes. Famous battlefields, homes of three presidents, Old South charm and Oak Ridge. All this awaits you in Tennessee . . . glorious vacationland for the whole family.

Write For **FREE COLOR BOOK**

Tennessee Division of Information  
1522 Cordell Hull Bldg., Nashville, Tenn.

Please send Free Color Book

NAME \_\_\_\_\_

ADDRESS \_\_\_\_\_

CITY & STATE \_\_\_\_\_



Mention the National Geographic—It identifies you

You'll see more of  
magnificent Canada from  
the Scenic Domes of

# The Canadian



**THE CANADIAN** offers daily service all year round between Montreal and Vancouver, or Toronto and Vancouver. For full information about first class, tourist or coach travel, consult your local travel agent or Canadian Pacific in principal cities in the United States and Canada.



**CANADA'S ONLY STAINLESS STEEL STREAMLINER** takes you along the famous Banff-Lake Louise Route through 2,881 miles of ever-changing scenery. You see the spectacular Canadian Rockies in broad daylight, when you can enjoy panoramic views from the Scenic Domes. And smooth diesel power makes the ride wonderfully comfortable.



**THE MURAL LOUNGE** is a perfect spot to enjoy refreshments, while you chat with old friends or make new ones. The décor is heightened by a mural painted by a distinguished Canadian artist.



**SIT BACK AND RELAX** in your reclining coach seat. Adjust full-length leg rests, comfortable foot and head rests to the positions you want. All seats are reserved.



**THE SKYLINE COFFEE SHOP** offers meals at popular prices. Enjoy the finest food in the Deluxe Dining Room Car.

VIEWLEX GUARANTEED FOR A LIFETIME

VIEWLEX GUARANTEED FOR A LIFETIME

VIEWLEX GUARANTEED FOR A LIFETIME

VIEWLEX GUARANTEED FOR A LIFETIME

**Viewlex**  
**SLIDE PROJECTORS**

as  
**MODERN**  
as  
tomorrow



or  
better  
camera stores  
everywhere

**POWERMATIC**

300 Watt fan cooled  
for 2x2 slide tray mount



**PROJECT-O-MATIC**  
300 Watt fan cooled Automatic  
2x2 slide projector,  
\$79.50 incl. case plus 6 trays.  
500 watt model \$88.50

Touch Bar control does it all electrically. Just sit back and relax. Use remote control from across the room or set the automatic timer to run itself. So automatic that room light turns off when projector turns on! \$119.50 incl. case plus 6 trays

**Ride Upstairs**  
**IN YOUR OWN HOME**



HomeLIFT

Enjoy one-floor convenience with the finest in home elevators . . . easily installed



Write for illustrated literature.  
**SHEPARD WARNER ELEVATOR CO.**  
5804 Grosherton Rd., Cincinnati 9, Ohio

**YOUR TRAVEL DREAMS COME TRUE!**

Go where you please, stay as long as you like. Explore the byways, relax by a rippling stream . . . enjoy the sea, the woods, the mountains—travel carefree with all the comforts of home, whether it's an extended vacation trip or a week-end camping jaunt. Write today for free booklet!

**FREE**  
**BOOKLET**

**WORLD**  
**AT YOUR**  
**DOORSTEP**



**AIRSTREAM TRAILERS Dept. AG.**  
110 CHURCH ST., JACKSON CENTER, OHIO  
12604 E. FIRESTONE BLVD., NORWALK, CALIF

*This...*

**ROCKY MOUNTAIN ROCKET**



*takes you to this...*



**Colorado**  
**Vacationland Supreme**

R. E. King, General Passenger Traffic Manager  
723 La Salle Street Station  
Chicago 5, Illinois

I am interested in a trip to \_\_\_\_\_

Also send me details about money-saving Family Fares.

Name \_\_\_\_\_

Address \_\_\_\_\_

City \_\_\_\_\_ Zone \_\_\_\_\_ State \_\_\_\_\_

(If for school, state grade \_\_\_\_\_)



The moment you board the ROCKY MOUNTAIN ROCKET your Colorado outing has begun. For here is travel as you *want* it—smooth-gliding, comfortable miles in modern coach or Pullman, where every travel hour provides 60 minutes of vacation pleasure. The ROCKY MOUNTAIN ROCKET leaves Chicago 2:00 pm—over the only direct route, Chicago to Colorado Springs and Denver.

**Mail Coupon for information**

**152 calories** in cake  
with chocolate sauce  
when you sweeten with sugar



**70 calories** in cake  
and sauce combined  
when you sweeten with Sucaryl



You can save a lot of calories by sweetening with Sucaryl  
*and you can't taste the difference*

Sucaryl makes it easier for you to watch your weight... by giving you wholly natural sweetness in your diet... without one single calorie.

Sucaryl is the first calorie-free sweetener that tastes just like sugar in ordinary use. You'll find it sweetens drinks, fruits, and cereal to perfection. Cook with it, bake with it; use it practically

anywhere you would sugar. Any Sucaryl-sweetened dish tastes just like its sugar-sweetened twin. Sucaryl, of course, is for anyone sensibly counting his or her calories, and for those who cannot eat sugar. You get Sucaryl in tablets or solution; low-salt diets call for Sucaryl Calcium. Abbott Laboratories, North Chicago, Illinois and Montreal, Canada. *Abbott*

**JUST OFF THE PRESS!**

Our brand-new cookbook, "Calorie-saving Recipes with Sucaryl", includes the recipes for the sugarless Sponge Cake and Low-Calorie Chocolate Sauce shown above. Also dozens of new, kitchen-tested ideas for desserts, sweet breads, sauces, dressings... 50 wonderful recipes in all! Get your free copy at your drug store.



**Sucaryl**<sup>®</sup>  
Non-Caloric Sweetener—No Bitter Aftertaste



Big league baseball plus outdoor opera in both Kansas City and St. Louis help make your Missouri vacation more exciting!

## more fun for less in **MARVELOUS MISSOURI**

The vacation of your life can be the thriftiest trip of years . . . in Missouri! For it's the state where you do more, see more, travel more—for less money! It's the family vacation land for the budget-minded family.

At historic Hannibal see Mark Twain's home and cave. At St. Louis, take a boat ride on Old Man River. Visit pre-Civil War mansions in Daniel Boone, Old Trails regions.



The famous columns of the first University of Missouri administration building. Also in Columbia are Stephens College and Christian College.

Four historic buildings at Arrow Rock and Lexington, home districts in Kansas City. Visit Noel, Branson, Rockaway Beach, Shepherd of the Hills Region. Fish in Lake Taneycomo, Bull Shoals, Norfolk, Clearwater, or Wappapella. Float the White, Current, Gasconade or Black rivers.

At Cape Girardeau see New Orleans opera house and train ferry at Ste. Genevieve. At Lake of the Ozarks, fish, rent a speed boat, swim, or just rest. Enjoy the finest vacation—for less in Missouri. Mail coupon.

Missouri Division of Resources & Development  
Dept. D742  
Jefferson City, Missouri

Please send full-color vacation literature on Missouri. No obligation.

Name \_\_\_\_\_

Address \_\_\_\_\_

City \_\_\_\_\_ State \_\_\_\_\_

# Bauer

8mm Automatic

NOW . . . professionally-perfect movies  
every time . . . with



## Electro Master

CONTROL

Engineered by Europe's foremost movie technicians. Foolproof, automatic operation. Fast F1.9 Schneider lens coupled to in-built electric exposure meter; 4 speeds plus single frame; film transport indicator; accessory lenses. Smooth, silent, precise. **\$149.50**

\* correct exposure automatically



Line up pointers . . . electric exposure meter automatically sets lens for perfect exposure.

At camera stores; or write for booklet series G4  
**INTERCONTINENTAL MARKETING CORPORATION**  
45-17 Pearson St. Long Island City 1, N.Y.

# Free . . . beautiful full-colour brochure of **BERMUDA**

A 16-page preview of a perfect vacation . . .  
colour photographs, helpful information.  
What to see, what to wear . . . sports,  
beaches, shopping, transportation,  
hotels and guest houses.

SEND COUPON TODAY!

The Bermuda Trade Development Board,  
Dept. N-74, 620 Fifth Ave., New York 20, N. Y.  
Please send illustrated Bermuda Brochure.

Name \_\_\_\_\_

Street Address \_\_\_\_\_

City \_\_\_\_\_ Zone \_\_\_\_\_ State \_\_\_\_\_



This  
is  
your  
year  
for  
travel

Ask your  
**TRAILWAYS**  
Agent about . . .

Straight-Thru Service  
Limited-stop Service  
Charter Coach  
Package Express  
Escorted Tours  
Package Tours  
Free Tour Planning

## go **TRAILWAYS**

This is the year to take advantage of the many travel features offered by Trailways. Luxurious air-conditioned Thru-Liner coaches (many with restrooms) will speed you swiftly and safely to your destination — without a change of bus, or transfer of baggage.

**FREE** tour planning is a special service of Trailways, so that your travel will be easy, relaxing, and enjoyable. Whether you are interested in an individually planned vacation, an escorted tour, or a charter coach trip for your group, just mail the coupon below and we'll send full color folders to help you get started on your way!



SEE AMERICA AT SCENERY LEVEL

TRAILWAYS, Dept. NG-47  
1012 14th St., N.W., WASHINGTON, D.C.  
Please send me **FREE** information on a trip.

To \_\_\_\_\_

From \_\_\_\_\_

Approximate Leaving Date \_\_\_\_\_

I am interested in  expense paid tour,  escorted tour,  vacation trip (check one).

Name \_\_\_\_\_

Street Address \_\_\_\_\_

City \_\_\_\_\_ State \_\_\_\_\_





exploring the world is easy with a **Leica M-3**

Only the LEICA M-3 gives you such a perfectly balanced combination of automatic components—and advanced optical innovations like the M-3's famous bright-line viewfinder system—that you find it easy to shoot memorable pictures...any time...anywhere. Add to this the outstanding quality of LEICA lenses and the traditional precision and ruggedness of the classic LEICA design. No wonder the M-3 is so sought-after a camera at home and abroad.

*lifetime investment in perfect photography*

LEICA, INC., 400 FOURTH AVENUE, NEW YORK 16, N.Y.  
 HEADQUARTERS OF THE WORLD FAMOUS PRODUCTS OF  
 ERNST LEICA & CO., WETZLAR, GERMANY. COMPLETE CATALOGUE  
 LENSES • CAMERAS • MICROSCOPES • BINOCULARS

79117

Your choice of **3** fascinating routes  
 to **ITALY**

*Via the Mediterranean*

★ New York direct to Naples by the  
 National Hellenic American Line's  
 popular 21,000-ton

**QUEEN FREDERICA**

*Via Northern Europe*

★ New York to Le Havre by  
 Home Lines' luxurious 21,000-ton

**ITALIA**

★ Montreal or Quebec to Le Havre  
 by Home Lines' 26,000-ton flagship

**HOMERIC**

GO ONE WAY... RETURN ANOTHER  
 ... DOUBLE YOUR TRAVEL FUN!

At sea you can relax, rest... enjoy  
 life at its best. Air-conditioned  
 dining salons... finest Continental  
 food and service.



See your Travel Agent

AGENCY INC. General Agents  
 42 Broadway, New York 4, N. Y.  
 Digby 4-6363



See the lovely scenery



Eat delicious food.

ENJOY BOTH IN  
**MAINE**

Either at lakeside or at the seashore, Maine has lots for you to do. You'll long remember the beautiful scenery and such delicious treats as our famous lobsters. You really relax and have fun on a Maine vacation. Plan now. Send for your free Vacation Planning Kit.

**FREE**

VACATION  
 PLANNING  
 KIT

Maine Dept.  
 Industry  
 & Commerce

MAINE VACATION SERVICE  
 1147 Gateway Circle, Portland, Maine

Name \_\_\_\_\_  
 Address \_\_\_\_\_  
 City \_\_\_\_\_ State \_\_\_\_\_

Mention the National Geographic—It identifies you

You'll never put hand and foot to a car so quick, smooth and easy to control — a light touch does it. Chevy's solid on the road — and that goes for the way it's put together, too!

A wonderful thing happens the very first time you take a '57 Chevrolet through traffic or slip it into a tight parking spot. You begin to realize that this car is not only beautifully built, but beautifully *behaved* as well!

In no time at all you're faced with the happy fact that this Chevy is a genuine pleasure to drive, and yet there's practically nothing to driving it! You can chalk this up to Chevy's sure and easy handling. That and also the cat-quick responsiveness of its velvety V8 engine.

Lively performance is part and parcel of Chevy's light-touch personality. That's why V8 options go all the way up to 245 h.p.\* That's also why new Turboglide—the first and only triple-turbine automatic drive—is offered as an extra-cost option! You can get the light-touch feeling firsthand at your Chevrolet dealer's. Make it soon....Chevrolet Division of General Motors, Detroit 2, Mich.



\*A 270-h.p. high-performance V8 engine also available at extra cost. Also Ramjet fuel injection engines with up to 263 h.p.

*you'll love Chevrolet's new light-touch driving!*



*The Bel Air Sport Coupe with Body by Fisher—one of 20 beautiful new Chevrolets.*

For Travel Memories  
You'll Cherish Always

See *Italy* first



VENICE



Whatever your tastes or interests . . . joyous satisfaction awaits you in Italy . . . and in a variety and abundance that defy cataloging. Beauty surrounds you—the beauty of nature . . . the beauty of man's finest genius. And life is good—leisurely or lively, as you please. Accommodations for all budgets . . . superb food . . . economical transportation. Low-cost de luxe motor coach tours operate throughout Italy . . . efficient domestic air service features reasonable fares . . . 15 and 30-Day Tickets permit unlimited rail travel . . . special coupons enable motorists bringing their own cars to buy gasoline at reduced prices. This summer . . . enjoy Italy . . . see your Travel Agent now!



**ITALIAN STATE TOURIST OFFICE—E.N.I.T.**

21 East 51st Street, New York 22, N. Y.

CHICAGO—  
333 N. Michigan Ave.  
NEW ORLEANS—  
International Trade Mart  
SAN FRANCISCO—  
St. Francis Hotel

SEE *Florida* AT ITS  
SUNNY BEST

This year when you visit this fascinating state be sure to make the NEW St. Petersburg your headquarters. You'll fall in love with this exciting metropolitan fun center and its sun-drenched beaches.

Write today for photo-packed folders which tell the vacation fun story. Learn why this is Florida's leading "Family Resort."



Let Us Help You Plan  
Your Vacation in  
The Sunshine

Mail Coupon **Now!**

G. G. DAVENPORT, Manager  
Chamber of Commerce  
St. Petersburg, Florida

Please send free illustrated folders

NAME \_\_\_\_\_

ADDRESS \_\_\_\_\_

CITY \_\_\_\_\_ STATE \_\_\_\_\_

No. in Party \_\_\_\_\_ Date of Arrival \_\_\_\_\_



Protect and file your

NATIONAL  
GEOGRAPHIC  
*MAPS*  
AND THEIR  
MAP INDEXES



To enable map users to preserve and organize National Geographic Maps and Map Indexes, The Society makes available a handsome Map Case. Bound like a book, with maroon-colored library buckram covers embossed in gold, the case contains ten file pockets to accommodate 20 folded paper maps or 10 maps with their indexes. Maps and indexes and their folder numbers may be recorded on a form provided for your convenience.

54 everywhere. U.S. funds. Postpaid. Write to:

**NATIONAL GEOGRAPHIC SOCIETY**  
Department 704, Washington 6, D. C.

Mention the National Geographic—It identifies you

# Enjoy the Happiest Weeks of Your Life



*Riders of trail and road at Swiftcurrent Lake.*

## in Glacier National Park 'way out West in the Montana Rockies

For the rest of your life you'll treasure the memories of a vacation spent in the rugged wilderness of Glacier National Park. Never-to-be-forgotten delights: wonderful hotels, marvelous meals, adventure on the mountain trails either on horseback or hiking.

### **Go Great Northern . . .**

Great Northern streamliners take you to the very doors of Glacier Park. So your vacation starts the moment you board the Western Star.

For information or reservations on travel to Glacier Park and other Western vacation areas, write **P. G. HOLMES**, *Passenger Traffic Manager*, Dept. N-47, Great Northern Ry., St. Paul 1, Minn., or consult your nearest ticket or travel agent.



# A CAR IS A MUST IN EUROPE...



**THIS ADVERTISEMENT IS OF PRIME IMPORTANCE TO EVERYONE PLANNING TO GO TO EUROPE THIS YEAR:**

You know what a car means to you here . . . Abroad, it will mean even more. There are so many places to go, so many things to see and yet the time is so short. Only a car of your own will give you the complete freedom you deserve for your vacation.



**THE PANHARD:** 5 Passenger Sedan one of the best selling cars in France today! Combines Three Cars in One!  
 1. Comfort of a Large Car (183 inches)  
 2. Economy of a Small Car (40 m.p.g.)  
 3. Performance of a Sports Car (Six-time winner of the Le Mans 24-hour Race.)



**CITROËN**—one of the greatest names in automobiles, offers you the possibility of having a car delivered to you DIRECTLY FROM THE FACTORY, brand new, with all necessary documents. Order your car here, and have it ready for you anywhere in Europe. Also, this is the cheapest way to travel because the factory repurchases the car in dollars at a guaranteed price. CITROËN has a car for every budget.

**CITROËN DS 19** is one of the cars you can buy and bring back to the U. S. for further savings. It is the only car to feature as standard equipment, hydraulic transmission, disc power brakes, power steering and the unique CITROËN® air-oil suspension. Also available is the PANHARD 5 Passenger Sedan, one of today's best sellers in France, and the extraordinary CITROËN "2CV" 4-door 4-seater, the most economical car in the world.

**FOR FREE BOOKLET, "Europe Geographic Plan,"** write or visit the factory showrooms today!

**CITROËN**  
 CARS CORPORATION  
 100 PARK AVENUE, NEW YORK 22, N. Y. • EL 3-2872  
 8423 WILSHIRE BLVD., BEVERLY HILLS, CALIF. • OL 3-4745  
 S. A. ANDRÉ CITROËN, 133 QUAI DE JAVIL, PARIS 15, FRANCE



Majestic Mount Rainier in Rainier National Park

## Marvel at mighty Mt. Rainier in **WASHINGTON STATE**

Glorious natural scenery is yours to enjoy as fine, broad highways take you past the mountains, rivers and lakes of Washington State.

**SEND TODAY**—for this beautiful, full-color booklet picturing Washington State vacation attractions:

*Yours for the asking:*

other booklets describing your special interest in:

- RECREATION     FISHING     CRUISING  
 PHOTOGRAPHY     MOUNTAINS and PARKS  
 (Check the ones you want)

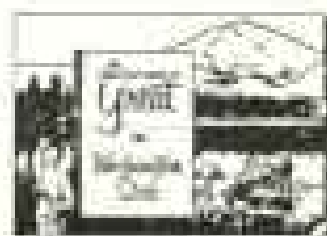

**WASHINGTON STATE ADVERTISING COMMISSION**  
 Room 3358, Dept. G7, Administration Bldg., Olympia, Washington  
 Please send me your FREE natural color booklet on Washington State.

Name \_\_\_\_\_  
 Address \_\_\_\_\_  
 City \_\_\_\_\_ State \_\_\_\_\_

PLEASE PRINT

*You'll also want to visit:*

**SEATTLE**  
 Metropolitan, glamorous seaport

**McNARY DAM**  
 Photogenic, scenic wonder

**OLYMPIC NATIONAL PARK**  
 Scenic mountains, fishing, giant trees

**LAKE CHELAN**  
 Swimming, boating, sun-bathing

**OLYMPIA**  
 Capitol buildings, gardens



# Most valued symbol of your devotion

When a diamond is your gift it bears with it the mark of your achievement.

Your good judgment is confirmed, for a diamond's value is enduring.

The giving of a diamond subtly demonstrates the quality of your discernment.

Your devotion is continually recalled when your gift is a diamond.

*This year, let a diamond make memorable that special anniversary, or important birthday, a debut, the birth of a child, or any significant event. "A diamond is forever."*



1/4 carat  
\$200 to \$400



1 carat  
\$600 to \$1200



2 carats  
\$1800 to \$3600



3 carats  
\$2225 to \$4450

Color, cutting and clarity, as well as carat weight, contribute to a diamond's value. A trusted jeweler is your best adviser. Prices shown cover range of qualities in January, 1967, by representative jewelers for their top-quality unmounted diamonds. (Federal tax extra.) Prices vary with top qualities offered. Exceptionally fine stones are higher.

De Beers Consolidated Mines, Ltd.





be in Sparkling Spain  
... overnight by "Super 7"!

Spain is rich in art . . . antiquity . . . gaiety and dignity. So economical, too: luxurious room and bath in a remodeled "Castle in Spain" for as little as \$4.<sup>50</sup> a day American Plan!

Step aboard a giant Pan Am radar-equipped "Super 7" Clipper\* . . . the quietest, fastest over-ocean airliner in the world! Your choice of first class *President* with berths (extra) or tourist-fare *Rainbow* service . . . be in Spain overnight for the vacation of a lifetime.

See your Travel Agent or

\*PAA Tour Map  
Reg. U. S. Pat. Off.

**PAN AMERICAN**

World's Most Experienced Airline

**SPANISH TOURIST OFFICE**

455 Madison Avenue, New York 22 • 39 South La Salle Street, Chicago 3 • 453 Post Street, San Francisco 2  
or any of PAA's offices in 33 principal cities

Men who are  
on their feet all  
day recommend..



**Dr. A. Reed**  
CUSHION SHOES

The shoe with the sole of comfort. Uppers of Kangaroo or Kid. Write today for free style booklet and name of nearest Dr. A. Reed store.



STYLE 130  
Black Kangaroo  
Also #134  
Brown Kid  
Sizes 6 to 12 — AAA to EEEE.

\$18.95

CONNOLLY SHOE CO., Stillwater 11, Minnesota

Where  
else —

but in  
**MONTANA?**

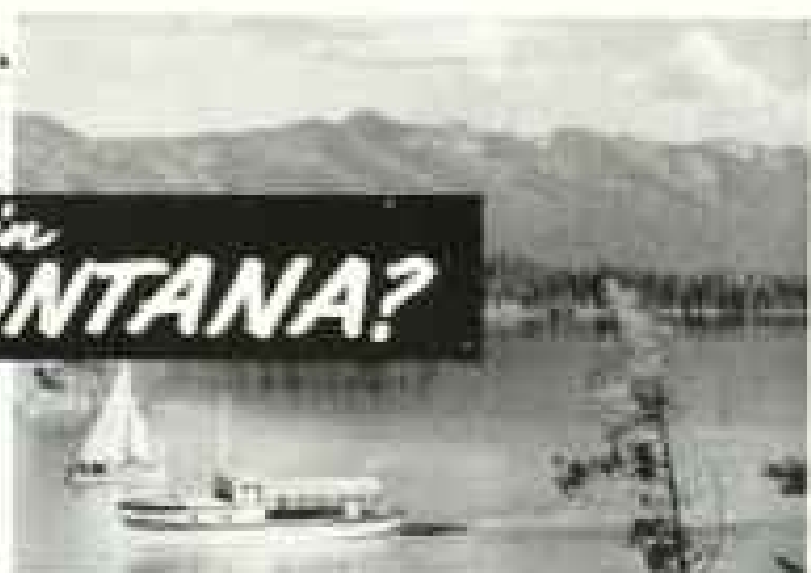

Perhaps at Lake Como you'll find a playground as lovely as the shores of Flathead Lake. But where—but in Montana—will you find so many kinds of outdoor recreation in so many scenic settings?

- GLACIER PARK—  
spectacular as the Italian Alps
- LEWIS AND CLARK CAVERNS—  
entrancing as the grotto of Capri
- COOKE CITY HIGHWAY—  
rolling as Switzerland's Scenic
- FORT PECK DAM—  
imposed as the Great Wall of China
- YELLOWSTONE PARK—  
wonderland as New Zealand

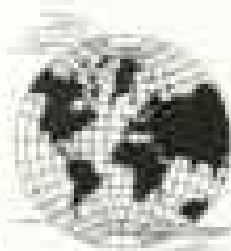

Advertising Director, Dept. 57-B  
Montana State Highway Comm.,  
Helena, Montana

Your **MONTANA**  
VACATION tour of  
the world's wonders.

Name \_\_\_\_\_

Address \_\_\_\_\_

starts  
with this  
coupon

Mention the National Geographic—It identifies you



1



2



4



3



5

## Have more FUN on your western trip!

Fun starts the moment you step aboard the Vista-Dome North Coast Limited. On this handsome Northern Pacific train you enjoy every traveling pleasure you could ask for—and more!

- 1 A cheerful Stewardess-Nurse makes you welcome. Her special duty is to look after your comfort, to make your trip truly pleasant.
- 2 Four Vista-Domes give you a high, wide and wonderful view of magnificent western scenery.
- 3 Tempting meals, including favorites like NP's "Great Big Baked Potato", are sure to win your praises!
- 4 Traveller's Rest, fascinating buffet-lounge, offers you warm-hearted western hospitality and budget meals in a colorful setting.
- 5 Scenic route through the Pacific Northwest (good California connections). Inexpensive, too, with low family fares.

For free booklet, "Northwest Adventure", write G. W. Rodine, 305 Northern Pacific Ry., St. Paul 1, Minn. Discover why travelers say, *Northern Pacific — really terrific!*



CHICAGO • TWIN CITIES  
SPOKANE • TACOMA  
PORTLAND • SEATTLE

## VISTA-DOME NORTH COAST LIMITED

Mention the National Geographic—It identifies you



GIRAFFE—lion—sable antelope—impala—a countless variety of wild game in its natural habitat—Kruger National Park—game which you can see and photograph safely from your car.

## 62 day SOUTHERN AFRICAN cruise

At sea . . . the utmost luxury in ocean travel! Land tours handled by established tour managers. Ask your Travel Agent for our exciting new cruise booklet.

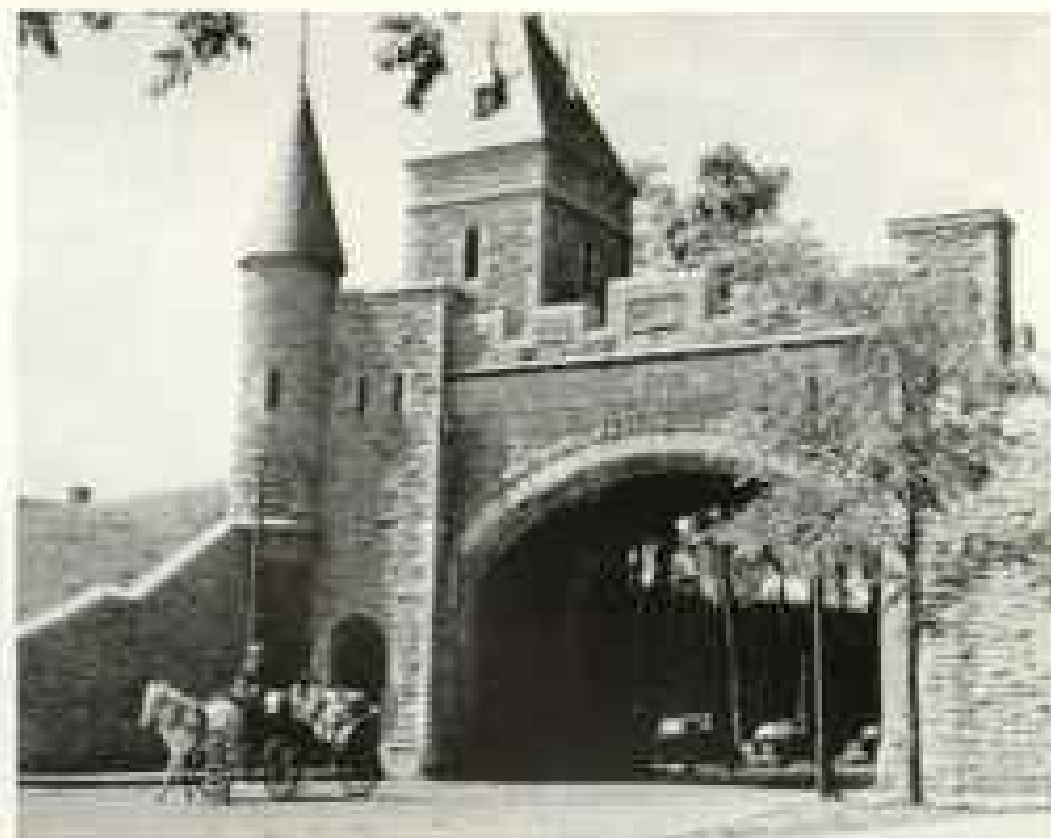

## Visit Old-World Québec

Visit the historic walled city of Québec, metropolitan Montréal, the picturesque villages along the mighty St. Lawrence, and nestling in the hills of the Eastern Townships, the Laurentian mountains.

For road maps and helpful information, write—Provincial Publicity Bureau, Parliament Buildings, Québec City, Canada; or 48 Rockefeller Plaza, New York 20, N. Y.

LA PROVINCE DE  
**Québec**



## FARRELL LINES

20 Beaver St., New York 4

WHitchall 4-7460



New thrill  
in travel planning



# SAS European Holiday



World's only Musical Travel Planning Kit

(6 brochures plus Mitch Miller musical)

Gay, exciting "European Holiday" brings your dream trip to life in Broadway musical style. Features TV stars, Mitch Miller magic, original songs and melodies. Offers valuable travel tips on 33 1/3 rpm Hi-Fi Record.

**50c**

Only 50c when purchased at your travel agent's office or \$1.00 by mail from S.A.S., use coupon below.

### VISIT 16 EXTRA CITIES at NO EXTRA FARE

Over 100 S.A.S. Extra-City trips to choose from. Most include London and Paris. Send for detailed folder.

### ROUND THE WORLD TOUR

All your travel dreams come true. Four continents—cities, seas, islands with magic names. See your travel agent. Ask about Pay Later Plan.



#### SCANDINAVIAN AIRLINES SYSTEM

638 Fifth Ave., New York 20, N.Y., Dept. G-4

- Please send FREE folders checked.  
 Enclosed is \$1.00 for complete S.A.S. Travel Planning Kit, with record and 6 brochures.

Name \_\_\_\_\_

Address \_\_\_\_\_

City \_\_\_\_\_ State \_\_\_\_\_

- Extra-City Folder  
 Round the World  
 Pennywise Tours  
 Passport Tips  
 Scandinavian Tours

Mention the National Geographic—It identifies you.

A sporting welcome  
to you from...

# GEORGIA



GO PLACES FASTER  
Be an Airman of the  
  
U.S. AIR FORCE



See the Cyclorama — authentic scene from the Battle of Atlanta



Visit Cherokee Chief Yarn's house in the North Georgia mountains

For the sports of presidents...and people... come to Georgia where golf courses stay green the year around—and some of the world's best fishing is to be found! If you want to fish, hunt, pan for gold, sightsee, water ski — or just get away from it all — see all of Georgia from the breathtaking Blue Ridge mountains to her sun-swept beaches!

## GEORGIA DEPARTMENT of COMMERCE

WRITE TODAY FOR FREE PICTURE-PACKED FOLDER

Scott Candler, Secretary, Dept. K  
Georgia Department of Commerce  
100 State Capitol, Atlanta, Georgia

Name \_\_\_\_\_

Address \_\_\_\_\_

City \_\_\_\_\_ State \_\_\_\_\_



## Camps



### 8 HAPPY WEEKS OF CULVER TRAINING

**SUMMER SCHOOLS**  
ON LAKE MICHIGAN

In NAVAL and HORSEMANSHIP SCHOOLS (boys 14-18) and WOODCRAFT CAMP (boys 9 1/2-14). Regular Academy personnel. Exceptional housing, dining and health facilities. 1300-acre wooded campus. Emphasis on correct posture, initiative, courtesy, self-reliance. Optional tutoring. All land and water sports. Moderate cost. State catalog desired. 49 Lake Shore Avenue, Culver, Indiana

### FARRAGUT NAVAL CAMPS

Season of adventure on Toms River for boys 8-12. Trips on 80-foot flagship, 42 land and water activities. Modern buildings, 2 gyms, 2 athletic fields. Approved summer school program available. Catalog: Farragut Naval Camps, Box LC, Toms River, N.J.

**GAY VALLEY** Boys & girls 6-12, 14-17 weeks. June 17-Aug. 3. Program of creative expression: arts, crafts, nature lore, woodcraft, dancing, dramatic music, riding. Private lake. Mature leadership. Two weeks Aug. 9-22 boys, girls 10-15. Catalog: Miss Mary W. Gwynn, Dir., Box N, Brevard, North Carolina

**CAMP LUPTON** On the Shenandoah. A carefully supervised camp for desirable boys ages 8 to 14. Excellent equipment & location on Shenandoah River in foothills of Blue Ridge Mts. All appropriate sports, shops & crafts. Own stable, riding master & instruction. Catalog: The Director, Box 45, Woodstock, Va.

**CAMP RED CLOUD** Ages 6-17. On Lake Champlain, Plattsburgh, N.Y. Riding, swimming, fishing, canoeing. 56-ft. cabin cruiser, 20 ft. racing sloop. Mature counselors. Screened cabins. Inclusive fee. Also make camp, Red Wing. Catalog: Mrs. Marvin N. Merryman, Jr., Dir., McDonagh, Maryland.

**SWISS HOLIDAY** Boys & girls, 12-18. Delightful living on Lago Maggiore with days of swimming, sailing, water skiing, tennis. Afternoons with camping & travel in Volkswagens to Aperia, Italy, France. Summer session of The School in Switzerland. Write: Villa Verbanella Alta, Locarno-Minusa, Ticino.

## Coed Schools

**ELGIN ACADEMY** Coed prep. Coed, grades 7-12. Small classes. Individual P.A.R. goals through personalized guidance. Balanced activities. Sports, gym, pool, music, drama. Art gallery. Modern campus. Endowed. Est. 1899. Write for catalog: M. L. Brett, 117 Academy Pl., Elgin, Illinois

### FENSTER RANCH SCHOOL

NATIONALLY KNOWN ranch school for boys and girls. Grades 1-12. College preparatory. Riding, swimming, other activities in warm, dry climate. For catalog, write: Mr. George D. Fenster, Director, Fenster Ranch School, Tucson, Arizona.

**OAKWOOD SCHOOL** An accredited Friends Boarding School. Grades 9-12. Strong college preparation. Religion, art, music, shop, typing. Guidance. Work program. Sports. Country campus 2 mi. from NYC. Est. 1788. Catalog: C. N. Hutton, Pr., Poughkeepsie, N.Y. GLOBE 4-9400.

**ORME SCHOOL ON QUARTER CIRCLE V BAR RANCH** Coed, ages 10-18. Fully accredited college preparation. High scholastic standards. Students help with chores on 45,000-acre working cattle ranch. Riding, team sports, trips. 2 1/2 hr. year. Also summer camp. Charles N. Orme, Jr., Director, Meyer, Arizona

**WAYLAND ACADEMY** N.E.A.B. Milwaukee. Chicago. Coed. College prep., grades 7-12. Accred. Small classes. Christian environment. Drama, music, speech. Athletics. 2 gyms, pool. Winter sports. Honor. Est. 1853. Catalog: R. A. Patterson, Headmaster, Box 73, Beaver Dam, Wisconsin

**WESTTOWN** A FRIENDS' school. Prepares boys and girls for college under the moral and spiritual standards of Quaker education. Grades 7-12. Apply now for Sept. 1956. Graduates in over 125 colleges. Established 1799. Catalog: J. Kirk Russell, Dir. of Admissions, Box 784, Westtown, Pa. (near Philadelphia).

## Girls' Schools

**FAIRFAX HALL** An old Virginia school in the famous Shenandoah Valley. Accredited 4 years high school. College prep., gen'l. courses. Secretarial, music, art, dramatics, home ec., interior dec. Sports, pools. Private stable. Catalog: Wm. B. Gates, Pres., Box N-574, Park Station, Waynesboro, Va.

### KINGSWOOD-CRANBROOK

Thomson college preparation, general courses, boarding, grades 7-1/2 day, grades 7-12. 30 acres on lake near Detroit. Unusual opp. in arts, handicrafts, sciences. Music, drama, sports, typing. Catalog: 150 Cranbrook Rd., Bloomfield Hills, Mich.

**LINDEN HALL** Johnston College and School for Girls. Cultural and Vocational. Music, Home Economics, Secretarial Studies. Fine and Commercial Art, Dramatic Art, Preparatory and General Courses. Beautiful Campus. All Sports. Riding. Swimming Pool. Moderate Tuition. B. N. Horne, D.D., Box 64, Lititz, Pa.

### MARYWOOD COLLEGE

ACCREDITED Catholic college for women. Liberal arts, librarianship, vocational home ec., teaching (elementary), music, art, drama, art., mod. tech., psych., voc'l. B.A., B.S., B.M., M.S. Sports. Dances. Catalog: Box E, Scranton, Pa.

**OAK GROVE** A FRIENDS' school for girls. Emphasizes Preparation for College and Gracious, Purposeful Living. Music, Art, Speech. Grades 7-12. International enrollment. Riding included. Joyous Outdoor Life. Beautiful Sleepywood Quadrangle. Mr. and Mrs. Robert Owen, Box 140, Vassalboro, Maine

**SULLINS COLLEGE** For young women. Accredited Jr. Coll. Liberal Arts & Career Courses. Music, Speech, Art, Soc'l., Mod. Soc'l., Miss'g., Home Ec., Phys. Ed., Ballet, Equestrian. Outstanding social program. All sports. Lake, Pool, Golf, Riding. Est. 1878. Catalog: William T. Martin, Pres., Box N-4, Bristol, Va.

## Home Study

### YOU CAN EDUCATE YOUR CHILD AT HOME

Kindergarten through 9th grade. You can give your child an accredited education with famous Calvert SCHOOL-AT-HOME Courses. Easy-to-follow teaching manual; books, supplies. Guidance by Calvert teachers. Often used to enrich learning programs of superior pupils. Start now! 1st year. Catalog: Give school grade, age.

CALVERT SCHOOL  
34 W. Tuscany Road, Baltimore 10, Md.

### HIGH SCHOOL at HOME

You can still finish High School—at home, in your spare time. No interference with job, or social life. Win more pay, a better job, social recognition. Take only the subjects you need. Complete lesson and answer service. Personalized instruction. Low cost. Diploma to graduate.

L.C.S. is oldest and largest (217 courses). Write today for 3 free books: (1) 56-page "How to Succeed," (2) sample lesson (Math), (3) Career Catalogue—indicate course desired.

INTERNATIONAL CORRESPONDENCE SCHOOLS  
Scranton 6, Penna. DEPT. 387480

## Vocational

### BRYANT COLLEGE

EARN YOUR BACHELOR'S DEGREE IN 2 YEARS. Train for Business Leadership. Study Business Administration; majors in Management, Accounting, Marketing. Also Even. Soc'l 2-yr. degree, majors in Admin., Med. Legal, Acctg. 4-yr. degree in Business Teacher Tr. Coed. 24 wings. Honor. Self-help Vet. app. Catalog: Enrollment Dir. Bryant College, Providence 4, R.I. Limited Enrollment. Register Early



**FRANKLIN TECHNICAL INSTITUTE** TWO-YEAR engineering courses prepare for excellent positions in Industry. Electricity & Electronics, Industrial Chemistry, Mechanical & Machine Design, Structural Design & Architecture. Graduates in demand. 485 yr. Catalog: 33 Berkeley Street, Boston 16, Massachusetts.

**INDIANA TECHNICAL COLLEGE** B.S. Engineering degree in 2 yrs. Aero., Chem., Civil, Elec., Mech., Electronics (Inv. Radio & TV), B.S. in 3 yrs. in Math., Chem., Phys. Prep. courses. Earn bonus. Demand for grads. G.I. app. Enter March, June, Sept., Dec. Catalog: 147 E. Washington Blvd., Ft. Wayne 2, Indiana

**TRI-STATE COLLEGE** B.S. Degree in 24 months in Bus., Civl., Elec., Chem., Aero., Radio (TV) Eng. In 24 months in Bus., Adm. (Gen. Bus., Acctg., Mkt. Tr. Mgt.). Fine campus. Prep. courses. Approved for Vet. Grads. successful. Enter June, Sep., Jan., Mar. Catalog: 1447 College Ave., Angola, Indiana

## katharine gibbs secretarial

BOSTON 18  
21 Marlborough St.  
NEW YORK 17  
281 Park Ave.  
MONTELAIR, N.J.  
23 Plymouth St.  
PROVIDENCE 6  
128 Angel St.

Outstanding training. Three practical courses.  
- One-Year Secretarial  
- Liberal Arts-Secretarial (Two years)  
- Special Courses for College Women  
Catalog: Assistant Dean

## Boys' Schools

### AUGUSTA MILITARY ACAD.

"The Friendly School." Distinguished ROTC school in Shenandoah Valley, Jr. & Sr. Divisions. Boys 6-20. Accredited. Graduate in leading colleges. All sports; pool, gym. Organized 1742. Rate \$1200. Catalog: Col. C. S. Koller, Box N, Ft. Defiance, Va.

### BAYLOR SCHOOL FOR BOYS

100th year. College prep. Accredited scholarship boys 12-18. Semi-military. Endowed awards. Ideal location. New gym. Championship athletics. Non-sectarian religious guidance. Summer camp, boys 8-15. Catalog: 103 Cherokee, Chattanooga, Tenn.

### BOLLES OF FLORIDA

Fully accredited. Distinguished academic record. Grades 7-12. Condensed type classrooms. Variety and intramural sports for all. Year-round golf, tennis, sailing. Outdoor swimming pool. Military or naval training. Write for 300+ catalog. Registrar, Box 5037-N, Jacksonville, Florida.

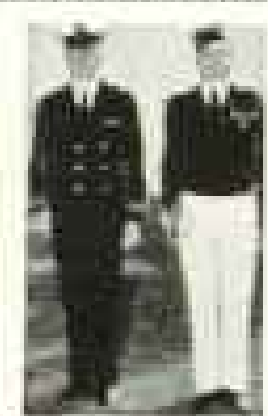

### BORDENTOWN MILITARY

ACCREDITED. College preparatory. Business, general. Aviation. Outstanding record of college entrance. ROTC. Boys taught how to study. Small classes. Sports. Jr. School. 10th yr. Summer session. Catalog: Registrar, Box 654, Bordentown, N.J.

### CARSON LONG

Boys' Military School. Educates the whole boy—physically, mentally, morally. How to learn, how to labor, how to live. Prepares for college, life or business. 10th year of character building. Overall charges \$1225.00. Box 21, New Bloomfield, Pa.

### CARTERET SCHOOL

Burton's College Prep. Prepares for College and Government Academies. Accredited. 1st Grade to College entrance. Small classes. Reading Techniques. Shops. Homeotic laboratory. Large gym. 49 acres atop Orange Mt. Moderate rate. N.Y. Drive 27 miles. Request Booklet D-7. Carteret School, West Orange, N.J.

## CASTLE HEIGHTS' MILITARY Highest Standards

Accredited. Preparation for College and Government Academies. Junior School in separate plant. Boys taught to study and inspired to excel. Guidance program. B.O.C.E.U. 17 modern buildings. Over 100 in activities. Military sports year-round. Non-profit. Swimming pool, golf, sailing. Summer school and camp. Est. 1923. Write for catalog, address: Est. R. N. Armstrong, Pres., Lebanon, Tenn. (Near Nashville)

### COLUMBIA MILITARY ACADEMY

Full year's Programs for Colleges and Gov't Academies. 14 buildings, 9 built by U. S. Gov't. 2 gyms, pool, ROTC. Weekly reports. Jr. School. All sports. Band, Orchestra, Honor School. Write for catalog and "Features". Dept. N, Columbia, Tenn.

### COLUMBIAN "THE SERVICE-ACADEMY PREP"

Executive, individualized preparation for West Point, Annapolis, Air Force Academy, etc., and all civilian colleges. How-to-study training. Est. 1909. Summer school. Columbian Preparatory School, 1854 Biltmore St., N.W., Washington 9, D.C.



Grades 8-12. Thorough college preparation. Accredited. Develops initiative, self-reliance, courtesy, character, leadership. All sports. Exceptional academic. Riding facilities. ROTC. Artillery, Cavalry, Infantry, Band. 1200-acre campus on Lake Michigan. Catalog: 49 Pershing Ave., Culver, Ind.

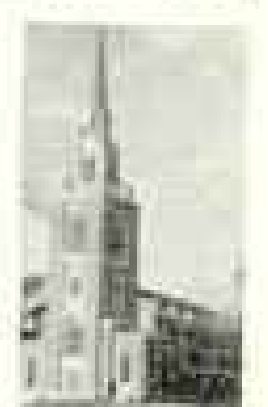

**DELBARTON SCHOOL** SELECT country day and boarding school for boys, grades 7-12. College preparation only. Excellent record. Active sports program. Small classes. Friendly atmosphere. 99 acres. Near N. Y. C. Catalog, Rev. Stephen A. Findlay, DSB, Marriestown, N. J.

**FARRAGUT** FULLY accredited college preparatory. Tom's River, N. J. 191. Ft. Meyers, Fla. Naval training. Separate Junior schools. Guidance for college and career. Sports, bands. Approved summer school and camp. Specify catalog desired. **Admiral Farragut Academy, Box L, Tom's River, New Jersey.**

**FISHBURNE MILITARY** DISTINGUISHED College Preparatory School, Grades 7-12. Fully accredited since 1907. Friendly, businesslike atmosphere. ROTC Highest Rating. Sports, pool. Constructive extracurricular, social programs. Catalog, **Col. E. P. Childs, Jr., Supt., Box N, Waynesboro, Va.**

**FORK UNION MILITARY ACADEMY**

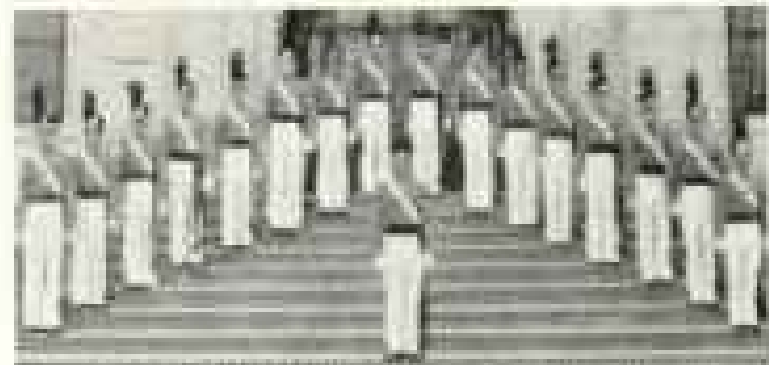

OUR ONE SUBJECT PLAN of study in Upper School (grades 9-12) has increased lower roll in... Overseas concentration. Fully accredited. ROTC Highest Rating. 12 modern bldgs., 2 completely equipped gym, pool. Meticulous maintenance, excellent health record. Junior School (grades 4-8) has separate buildings, gym. Home-mothers, 3000 yr. For ONE SUBJECT PLAN booklet and catalog write:

**Dr. J. C. Wicker, Box 304, Fork Union, Va.**

**GEORGIA MILITARY ACADEMY**

4 miles from Atlanta: Winter and Summer school. R.O.T.C. highest government ratings awarded. Prepares for all colleges and the national academies. Separate Junior School, two year seventh grades. Heated to 100 hearing seats. Post-graduate course. Reading Clinic, completely equipped with electronic apparatus, under supervision of a reading expert. All major sports. Expert coaches develop teams. Heated at 100 seats at gym, classes. Indoor pool. Cafeteria live-in small groups with teachers. Modern rates.

Write **Col. W. N. Brewster, College Park, Georgia**

**GREENBRIER MILITARY SCHOOL**

10th yr. The School of Achievement. 7th & 8th grades and H.S. and P. G. Dept. ROTC. White Sulphur Springs golf & swim pool. Athletics for all. New 100 acre range & gym. Catalog, write **D. T. Moore, Box M 304, Lewisburg 3, W. Va.**

**HARGRAVE MILITARY ACADEMY**

FULLY accredited. College preparatory, general courses. Grades 7-12. Home-study training; remedial reading; (individual guidance). Separate Jr. School. All sports. Summer School. Est. 1888. Catalog, **Col. Jos. H. Coshy, Box N, Chatham, Va.**

**HOWE MILITARY SCHOOL**

Academic training in spiritual environment. Accredited prep., business. Potential Achievement Rating given each boy a goal. Jr. School. Sr. ROTC. New dorms and pool. Episcopal. Summer Camp. Catalog, **B. B. Bouton, 947 Academy Pl., Howe, Ind.**

**JUDSON SCHOOL**

RANCH school for 100 boys 7-12 in beautiful, warm, dry climate. Small classes; accredited to eastern and western colleges; riding & polo included in tuition. Tennis, swimming, fishing, pack trips. 20th year. Catalog, **H. N. Wick, D. M. Ashley, Dir., Scottsdale, Arizona**

**KEMPER**  
Leading Military School for 113 years. Accredited; highest academic standing. Individual attention to each student. Grades 7-12. Junior College. Modern buildings. All sports. Write to Director of Admissions, **Kemper Military School, 1047 Third St., Knoxville, Missouri.** Our representatives will tell you complete details. No obligation.

**MANLIUS**

Founded 1889. For boys. Accredited. Grades 7-12. Complete college preparation. ROTC. Highest U.S. Army rating for over 50 years. 120-acre campus. Remedial reading. Sports. Band. Summer session. Tutorial assistance. Catalog, **Robert N. Weches, The Manlius School, Manlius, New York.**

**KENTUCKY MILITARY INSTITUTE**



A School with a winter home in Florida

PREPARATION for college under ideal climatic conditions all year. Oldest private Military School in America. ROTC. For illustrated catalog and "Why Florida" folder, address:

**Col. C. B. Richmond, Pres., Box N, London, Ky.**

**MARION INSTITUTE**

10th year. Accredited Junior College, 4-year College Preparatory in heart of Deep South. Special preparation for Army, Navy, Air Force Academies. Senior R.O.T.C. Sports. Mild climate. Individual attention. Catalog, Registrar, **Marion Institute, Box N, Marion, Alabama**

**MASSANUTTEN MIL. ACAD.**

ACCREDITED. College Prep. New Dormitory & class rooms. In beautiful Shenandoah Valley. Small classes. R.O.T.C. All sports. Gym. Pool. Band. Rifle Team. Riding. Grades 7-12. For catalog, address **Col. H. N. Benchaff, Woodstock 3, Virginia.**

**McDONOGH**

ONE of the Nation's leading preparatory schools. Grades 7-12. Accredited. Prepares for all colleges, service academies. Small classes, guidance. Music. Dairy and animal husbandry. Semi-military. Sports. 2 gyms, indoor pool, 30 horses. Est. 1875. Catalog, **H. L. Lamborn, Ed. D., Box 106, McDonogh, Md.**

**MERCERSBURG ACADEMY**

GRADUATES outstanding in leading colleges. Boys. Grades 7-12. Public speaking. Small classes. Beautiful campus. Famous chapel. Gymnasium. Pool. Athletics for all. Established 1831. Catalog, **Charles S. Tippetts, Ph.D., Box N, Mercersburg, Pa.**

**MIAMI MILITARY ACADEMY**

ACCREDITED. 35 acres on Biscayne Bay. College prep. & H.S. Separate buildings grades 7-8. Avoid winter illnesses. Band. Rifle. Swimming. Fishing. Golf. Tennis. Moderate all inclusive fee. Catalog, **Box 23, 10601 Biscayne Blvd, Miami 38R, Fla.**

**MILFORD**

COLLEGE preparatory school for boys. Famous for its teaching since 1874. Grades 7-12. Very small classes develop good study habits. Optional acceleration for mature students completes 1 1/2 years' work in 12 months. Spacious campus. Summer session starts July 5. **William D. Pearson, Hdm., Milford 11, Conn.**

**MISSOURI MILITARY ACADEMY**

AND Separate Junior School. 8th yr. Grades 7-12. Fully accredited. Sr. ROTC. Friendly, inspiring teachers. Small classes. Strong remedial reading and guidance program. All sports. Golf. 20 acre range. Athletic fields. 200-acre campus. Catalog, **Col. C. R. Stribling, 947 Main St., Mexico, Mo.**

**MORGAN PARK MILITARY**

Separate academic program under inspiring faculty. Accredited; 90% enter college. Small classes. Grades 7-12. ROTC. Cavalry. Band. Fine arts. Shop. Sports; teams for all. 8th yr. Catalog, **Col. C. L. Jordan, Box 747, Morgan Pk., Chicago 43, Ill.**

**NORTHWESTERN MILITARY AND NAVAL ACADEMY**

ORIGINAL prep. est. 1888. Accredited. 75 mi. in Chicago, 22 in Milwaukee. Avg. class D. Fireproof buildings. Modern facilities. 50 acres on lake. Sr. ROTC Base. All sports; sailing. Spenser Camp. Catalog, **54 So. Lake Shore Road, Lake Geneva, Wis.**

**PEDDIE**

COLLEGE preparatory. Grades 7-12. Endowed. Fully Accredited. Individual guidance; remedial reading; public speaking required. All sports, golf, swimming. Separate Junior School. 280 acres. Summer session. 32nd year. Catalog on request. **Dr. C. O. Marong, Headmaster, Box 4-N, Hightstown, N. J.**

**RIVERSIDE**

Health and interest assured by Spring and Fall in Georgia Mts., Winter at Hollywood, Florida—two complete school plants, each with all facilities. Outdoor sports year round. Fully accredited college preparation. Also Post Graduate Dept. Constant association with selected teachers who live and eat with cadets. Weekly reports. ROTC. Progress GUARANTEED. Reasonable all-inclusive fee. Outstanding record. Athletics for all. Separate Junior High, grades 7-8.

For illustrated catalog, address

**GENERAL SANDY BEAVER, President**

**WINTER NEAR MIAMI** Box 304-R, Gainesville 3, Fla.

**FALL & SPRING IN BLUE RIDGE MOUNTAINS**

**PEEKSKILL MILITARY ACADEMY**

12th year. Successful college preparation. High achievement records in college and life. Non-profit. Small classes. Personal interest in each boy. Athletic teams for all, intramural & varsity; swim pool, band, gym club, rifle team, camera club, etc. Separate Junior School 3rd grade up. Home-mother. Summer Session. For illustrated catalog, write:

**Headmaster, Box 306, Peekskill-on-Hudson 3, N. Y.**

**RANDOLPH-MACON MILITARY ACADEMY**

6th Year. At northern entrance to Skyline Drive. Prepares for college by intensive study methods. Fireproof bldgs. superior equipment. For catalog and "Your Boy" write: **Col. John C. Boggs, Pres., Box E, Front Royal, Va.**

**ST. JOHN'S MILITARY ACADEMY**



Where boys become self-confident men. Accred. college preparation under James St. John's System. Grades 7-12. Inspired teaching; small classes. Banding Officer. ROTC. Fireproof dorms. Sports. Summer camp. 2nd year. Catalog, **Dir. of Admissions, Box 1347, Delafont, Wisconsin**

**SAINT THOMAS MIL. ACAD.**

PREPARATORY training in Catholic environment. Accredited. Attention to each boy. ROTC. All sports; golf, pool, gym, band, choir. Chapel, infirmary. 60-acre campus. 7th year. Catalog, **Box 2, Rev. Leo White, St. Thomas M.A., St. Paul, Minn.**

**SEWANEE MILITARY ACAD.**

Division Unit, of the South. Fully accredited. Grades 7-12. Boys Taught to Study. ROTC. Highest Rating. Sports, pool. 10,000-acre mountain domain. Episcopal. 90th year. Catalog, **Col. Craig Alderman, Supt., Box N, Sewanee, Tenn.**

**SHATTUCK SCHOOL**

BOYS, Grades 7-12. Refined educational, religious, military. Accredited college prep. General courses. Small classes. Sr. ROTC. Sports. Gym, pool, golf. Episcopal. Est. 1892. Summer School. Catalog, **Dir. of Admissions, 575 Shumway Hall, Faribault, Minn.**

**STAUNTON MILITARY ACADEMY**

In beautiful Shenandoah Valley. Thorough college preparation; fully accredited. Individual guidance. Band. All sports. 2 gyms. Pool. Fine health resort. Fireproof buildings. Separate Junior School. 11th. Catalog write **Supt. S.M.A. Dr. H. Staunton, Va. BASIC COURSE R.O.T.C. BY U. S. ARMY INSTRUCTORS. Founded 1860**



**SULLIVAN SCHOOL**

EFFECTIVE and thorough preparation for Annapolis, West Point, Coast Guard and Air Force Academies, and all military. Catalog, **Wendell E. Bailey, U.S.N.A. 1934, Principal, Box D, 2107 Wyoming Avenue, N.W., Washington 8, D. C.**

**TENNESSEE MILITARY INSTITUTE**

Here planning to attend leading engineering schools and leading colleges need thorough preparation. Over 90% of graduates enter colleges. Grades 7-12. Small classes, 8th yr. Catalog, **Col. C. R. Endsley, Jr., Box 147, Sweetwater, Tenn.**

**VALLEY FORGE MILITARY ACADEMY**

"At the Nation's Shrine"  
Prepare your boy for leading colleges while he trains for a commission in the Armed Services. Small classes, highest academic standards. Prep. School and Jr. College, fully accredited; Arly. Cav., Inf., Senior Div. ROTC. All sports. Band. Ages 12-20. Catalog, **Box M, Wayne, Pa.**

**WENTWORTH MILITARY ACADEMY**

Thousands of business, professional leaders started here. 4-yr. High School; separate 2-yr. College. Accredited. Sr. ROTC. C.A. Riding. Modern buildings, country club. All sports; pool. Summer School. 18th year. Catalog, **Col. Sellers, 847 Wash. Place, Lexington, Mo.**

**WESTERN MILITARY ACADEMY**

Emphasis on self-confidence, self-direction, law-to-study. Small classes, guidance. Grades 7-12. Career analysis. Jr. Sr. R.O.T.C. Athletics; riding, pool. 7th year. Near St. Louis. Catalog, **Col. Ralph B. Jackson, Supt., Box N-4, Alton, Ill.**

**BULB BLOW?  
SPOILED SHOW?**



**BUY A PAIR!  
HAVE A SPARE!**

**GENERAL ELECTRIC  
PROJECTION LAMPS**  
For All Slide and Movie Projectors

**GENERAL  ELECTRIC**

See the Stars, Moon, Planets Close Up!  
3" "PALOMAR, JR." REFLECTING TELESCOPE  
60 and 120 Power—An Unusual Buy!



You'll see the Rings of Saturn, the fascinating planet Mars, moon craters on the Moon, Star Clusters, Moons of Jupiter in detail, Galaxies! Non-breakable aluminum covered tube. Equatorial mount with lock on both axes. Aluminized and overcoated 2" diameter high-speed F.18 ventilated mirror. Telescope comes equipped with a 5X eyepiece and a mounted Barlow Lens, giving you 60 and 120 power. An Optical Finder Telescope, always so essential, is also included. Sturdy hardened portable tripod. Free with scope: Valuable STAR CHART and 100-page book, "Discover

the Stars". Stock No. ES,050-D..... \$29.50 f.o.b. (Shipping wt. 10 lbs.)  
Barrington, N.J.

Order by Stock No.—Send Check or M.O.—Satisfaction Guaranteed—

**WRITE FOR FREE CATALOG—D**

We are Astronomical Telescope headquarters! Huge selection of Telescopes, Microscopes, Binoculars, etc., optical parts and accessories.

**EDMUND SCIENTIFIC CO. • Barrington, N. J.**

**HAVE YOU  
GIVEN TO  
EASTER SEALS?**

National Society  
for  
Crippled Children  
and Adults  
11 So. LaSalle, Chicago 3

**RECOMMENDATION FOR MEMBERSHIP**

PLEASE FILL IN BLANKS BELOW, DETACH AND MAIL TO

The Secretary, National Geographic Society  
Washington 6, D. C.

1957

*I nominate* \_\_\_\_\_

PRINT NAME OF NOMINEE

STREET

CITY, ZONE, & STATE

OCCUPATION

*for membership in*

**NATIONAL GEOGRAPHIC SOCIETY**

Membership dues, which are for the calendar year, include  
Subscription to the National Geographic Magazine.

PRINT NAME OF NOMINATING MEMBER

ADDRESS

**DUES:** Annual membership in United States, U.S. Poss., and Canada, \$6.00; countries in the Postal Union of the Americas and Spain, \$6.50; British Isles, £3 10s. 0d. British sterling (\$7.00); elsewhere, \$7.00. Life Membership, \$150.00 U.S. funds. Make remittances payable to and send direct to National Geographic Society. 4-57

Please fill in these spaces IF this is a GIFT membership:  
I enclose \$\_\_\_\_\_ for nominee's dues. Please send gift announcement card in my name to my nominee:  Yes.  No.

Mention the National Geographic—It identifies you.



*designed for today...  
for someone  
who loved you*

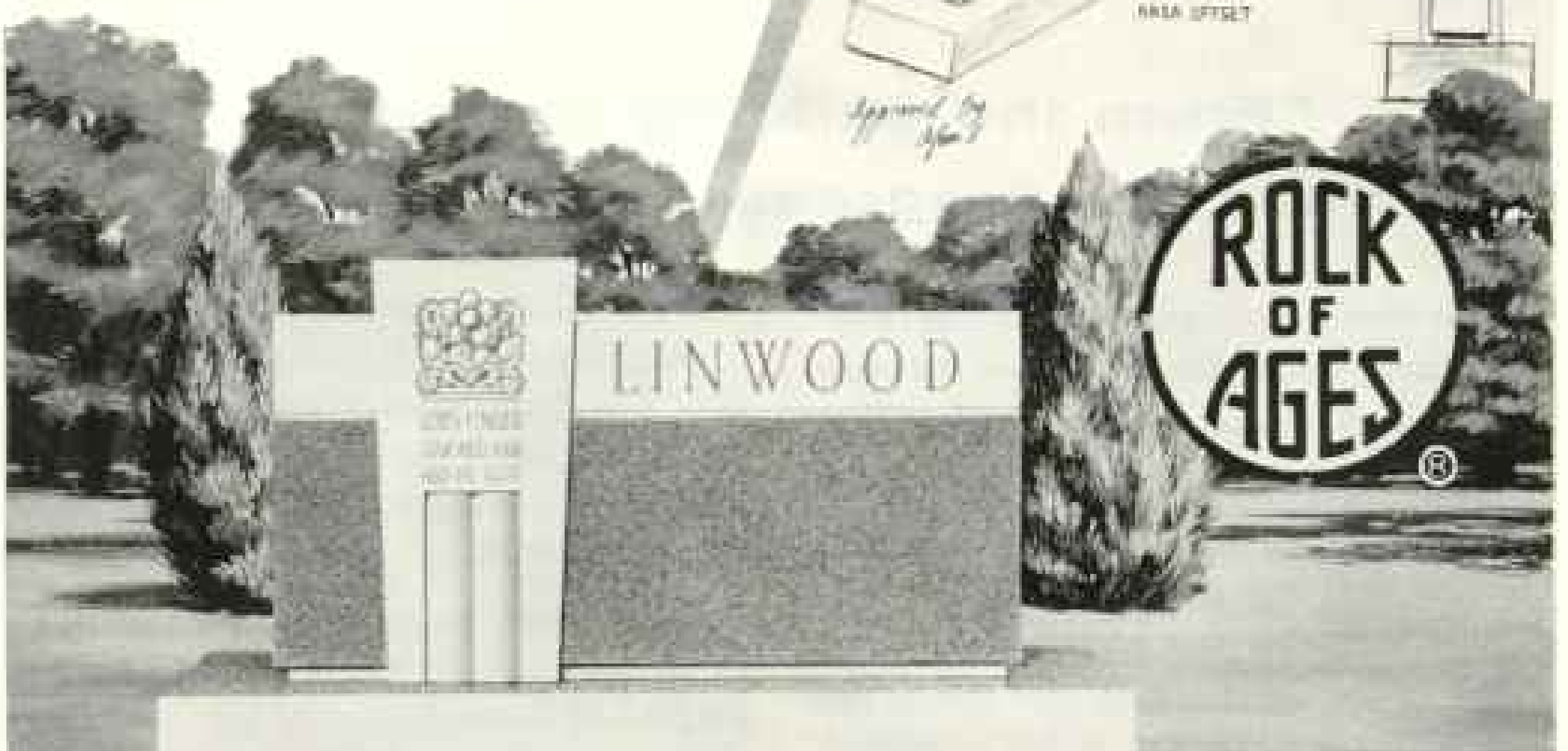
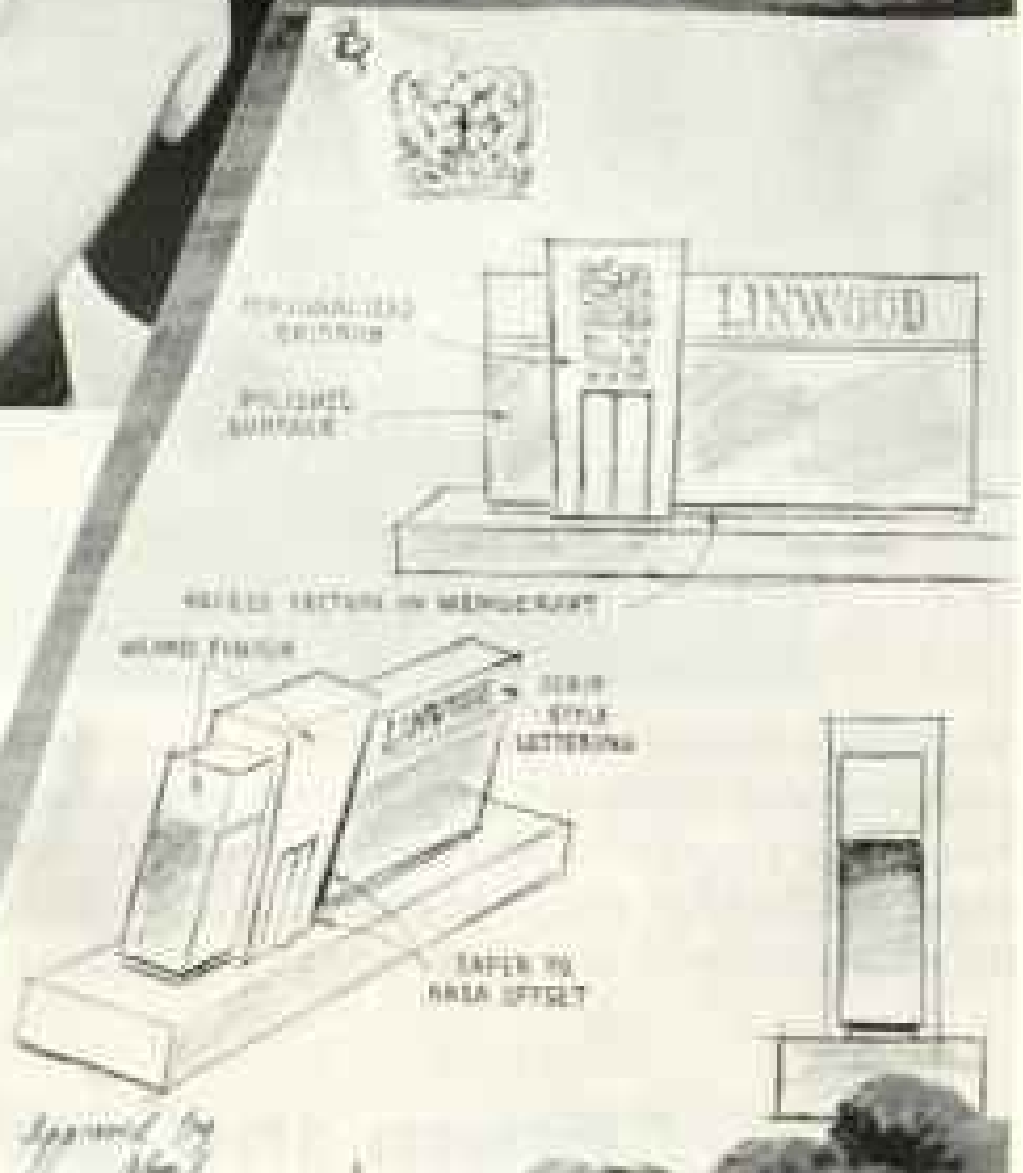

Find Your Nearest Dealer in The Yellow Pages

ROCK OF AGES MEMORIALS • BARRE • VERMONT  
©1957  
In Canada, Box 44, Toronto 17

Mention the National Geographic—It identifies you.



**TELEPHONE MEN AND WOMEN** attend one of the training courses in day-to-day matters of telephone service, employee and public relations. These particular courses are for management people in the Bell Telephone Companies throughout the country. There are many other Bell System programs for the training and advancement of telephone people at various stages of their careers. They include broad liberal arts courses at leading universities as well as schools within the business for executives.

## **"From the building of people comes the progress of the business"**

*Bell System's management training programs benefit telephone users and the company as well as telephone men and women*

There is nothing more important to good telephone service and to the future of the business than the finding and developing of capable people.

The Bell System has long been among the leaders in this field and it has pioneered many new methods for the training of telephone men and women at various stages of their careers.

What we aim to do is to provide both the opportunity and the preparation for a better job. The long-standing policy of making promotions from the ranks also helps to assure the continuing know-how and spirit of the organization.

This in turn brings far-reaching benefits to all who use the telephone and to the progress of the company.

It is an important reason for today's good service and the solid foundation for still better things to come.

*Working together to bring people together ...* **BELL TELEPHONE SYSTEM**



**FIRST LADY** One hot summer day in 1906 Bess Emily wanted an ice cream cone . . . from a store three miles across Lake Okauchee, Wisconsin. So, her husband, Ole Evinrude, rowed the whole distance. It was enough to start him thinking . . . thoughts that led straight to the first successful outboard motor . . . first in the Evinrude line that has brought new outdoor fun to millions.

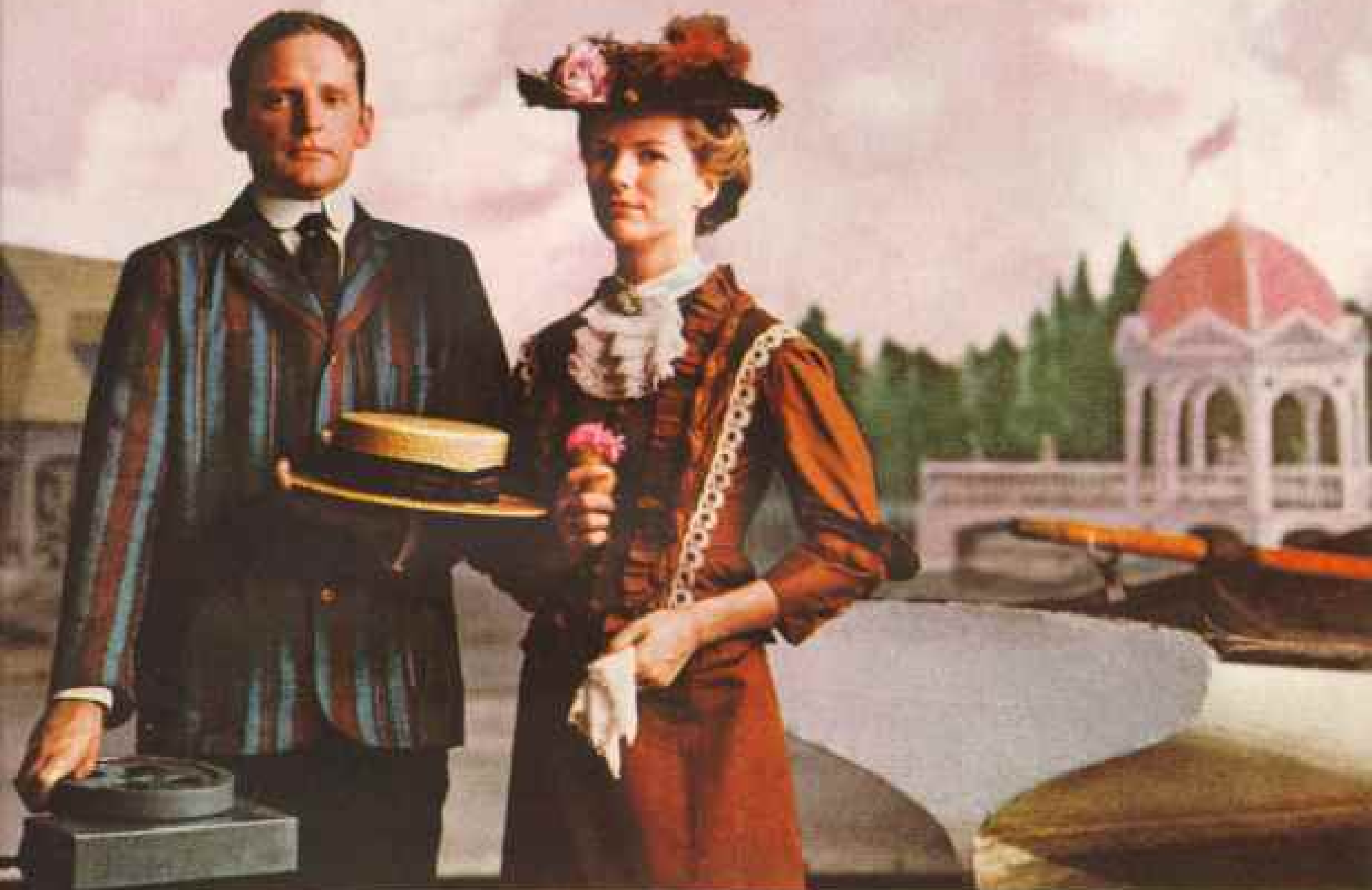

for the best in modern living, millions enjoy the products of  
**OUTBOARD MARINE** *Corporation*

DIVISIONS: EVINRUDE MOTORS, MILWAUKEE, WIS. • JOHNSON MOTORS, WAUWATON, ILL. • SALE PRODUCTS, GALESBURG, ILL. • LAWN-BOY, LAWAN, MO.  
 REPRESENTATIVES: OUTBOARD MARINE CORPORATION OF CANADA, LTD., PETERBOROUGH, ONTARIO • INDUSTRIAL ENGINEERING LTD., VANCOUVER, BRITISH COLUMBIA

Wherever sporting Americans gather you'll find Evinrude motors adding to the fun. Join them! Enjoy the spray, the crisp air, the feeling of going . . . and going with the best. See your Evinrude dealer today for a free "Revelation Ride."

OUTBOARD MOTORS  
**Johnson**  
**Evinrude**  
SALE PRODUCTS



LAWN MOWERS  
**LAWN-BOY**  
CREATED 1941  
**Pioneer**

