



GRADE 1

LANGUAGE ARTS, MATH AND SCIENCE

Workbook



A E I O U
DRUM

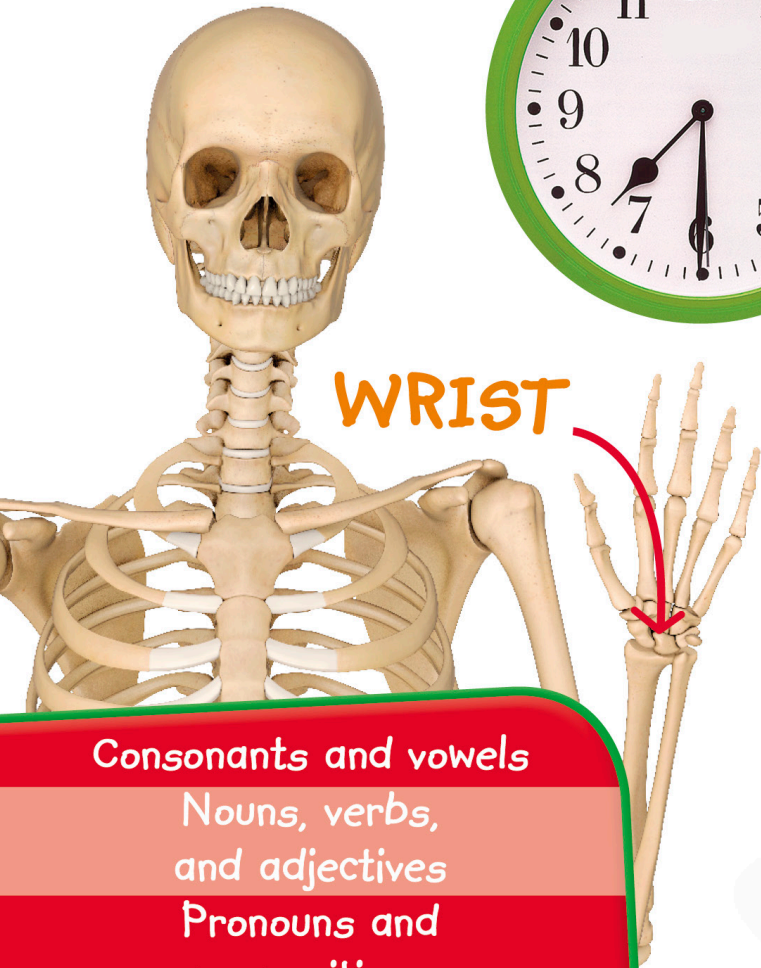

Consonants and vowels

Nouns, verbs,
and adjectives

Pronouns and
prepositions

Adding and subtracting

Money math

Time

Human body

Solids, liquids, and gases

Makes learning easy and fun
Builds and boosts key skills



WORKBOOKS

1st
Grade

Language Arts, Math and Science

Authors Linda Ruggieri (Spelling, Math),
Anne Flounders (Language Arts),
Hugh Westrup (Science)

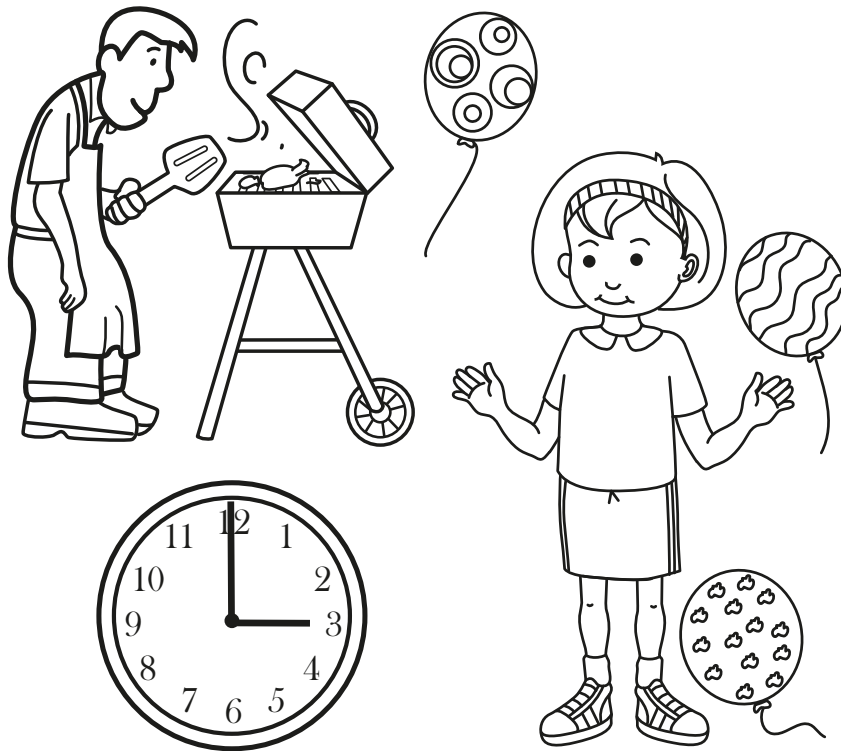



Penguin
Random
House

DK London

Editors Elizabeth Blackmore, Camilla Gersh, Jolyon Goddard,
US Editors Margaret Parrish, Allison Singer
US Educational Consultant Alison Tribley
Senior Editor Cécile Landau
Senior Designer Marisa Renzullo
Managing Editor Christine Stroyan
Managing Art Editors Richard Czapnik, Anna Hall
Jacket Design Development Manager Sophia MTT
Associate Publishing Director Liz Wheeler
Publisher Andrew Macintyre
Art Directors Karen Self, Martin Wilson
Publishing Director Jonathan Metcalf

DK Delhi

Project Editor Neha Ruth Samuel
Editors Rohini Deb, Nandini Gupta, Nishtha Kapil
Art Editors Dheeraj Arora, Jyotsna Julka, Baibhav Parida
Senior DTP Designer Tarun Sharma
DTP Designers Harish Aggarwal, Rakesh Kumar, Anita Yadav
Managing Editors Soma B. Chowdhury, Kingshuk Ghoshal
Managing Art Editors Ahlawat Gunjan, Govind Mittal
Jackets Editorial Coordinator Priyanka Sharma

Bindup Edition

Editor Anuroop Sanwalia
Senior Editor Fleur Star
Designer Ankita Sharma
DTP Designer Anita Yadav
Managing Editors Shikha Kulkarni, Christine Stroyan
Managing Art Editors Anna Hall, Priyanka Thakur
Jacket Designer Jomin Johny
Pre-Production Manager Balwant Singh
Production Editor Andy Hilliard
Production Controller Ed Kneafsey

First American Edition, 2020
Published in the United States by DK Publishing
1450 Broadway, Suite 801, New York, NY 10018

Copyright © 2020 Dorling Kindersley Limited
DK, a Division of Penguin Random House LLC
20 21 22 23 24 10 9 8 7 6 5 4 3 2 1
001-323713–August/2020

All rights reserved.

Without limiting the rights under copyright reserved above, no part of this publication may be reproduced, stored in or introduced into a retrieval system, or transmitted, in any form, or by any means (electronic, mechanical, photocopying, recording, or otherwise), without the prior written permission of the copyright owner. Published in Great Britain by Dorling Kindersley Limited.

A catalog record for this book is available from the Library of Congress.
ISBN: 978-0-7440-3806-4

DK books are available at special discounts when purchased in bulk for sales promotions, premiums, fund-raising, or educational use. For details, contact: DK Publishing Special Markets
1450 Broadway, Suite 801, New York, NY 10018
or SpecialSales@dk.com

Printed and bound in Canada.

All images © Dorling Kindersley Limited
For further information see: www.dkimages.com

For the curious

www.dk.com

Contents

This chart lists all the topics in the book.

Page	Topic
4	Letters and Sounds
5	Beginning Consonants
6	Ending Consonants
7	Consonant Blends
8	The Vowels
9	Missing Vowels
10	Beginning Consonant Blends
11	Ending Consonant Blends
12	Digraphs at the Beginning
13	Digraphs at the End
14-15	Sight Words
16-17	Pronouns
18	Verbs

Page	Topic	Page	Topic	Page	Topic
19	Present Tense	35	Practice Adding Up	51	Months and Years
20	Past Tense	36	Subtraction from 0 to 10	52	The Muscles
21	Future Tense	37	Practice Subtraction	53	The Bones
22	Singular to Plural Nouns	38	Recognizing Money	54	The Organs
23	Nouns and Verbs	39	Adding Money	55	The Heart
24	Is and Are	40	Double Trouble	56	Matter
25	Word Endings	41	Shopping	57	Solids
26	Adjectives	42	Figuring Out Change	58	Liquids
27	Prepositions	43	Giving Change	59	Mixing Solids and Liquids
28	Tens and Ones (Place Value)	44	Telling the Time: O'Clock	60	Heat and Dissolving
29	Finding Tens and Ones	45	Half Past	61	Gases
30	Show One More	46	Writing the Time: O'Clock	62	Water
31	Show One Less	47	Writing the Time: Digital	63	Weather
32	Find Ten More	48	Using Clocks	64	Certificate
33	Find Ten Less	49	Differences in Time	65	Parents' Notes
34	Adding Up to 10	50	Days of the Week	66-80	Answers



Letters and Sounds

FACTS

Aa Bb Cc Dd Ee Ff Gg Hh Ii Jj Kk Ll Mm
Nn Oo Pp Qq Rr Ss Tt Uu Vv Ww Xx Yy Zz

We spell words using the 26 letters of the alphabet. The alphabet has uppercase and lowercase letters, which are written together above. Letters are either consonants or vowels.

Circle the letter that makes the beginning sound of the name of each picture.



u s

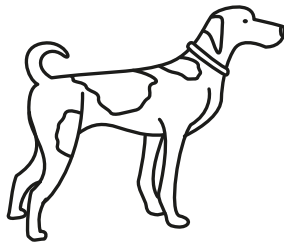

b d



m b

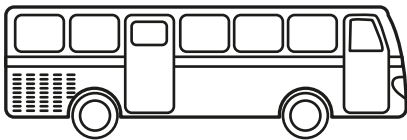

b s



c s

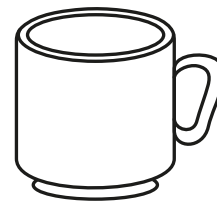

c f

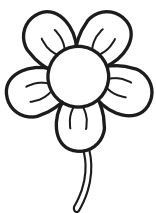

w f



a q

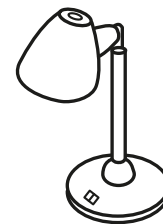

l h



There are 20 consonants in the alphabet. Five letters in the alphabet (**a**, **e**, **i**, **o**, and **u**) are always vowels. The letter **y** is sometimes a consonant and sometimes a vowel. Consonants often come at the beginning of words.

Write the letter that begins the name of each picture.

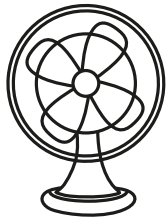

__an

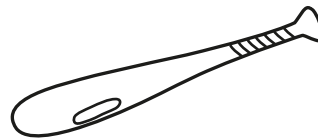

__at

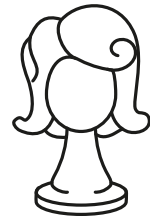

__ig

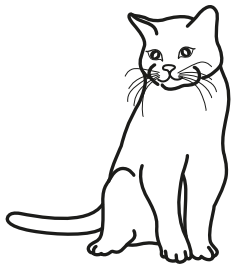

__at

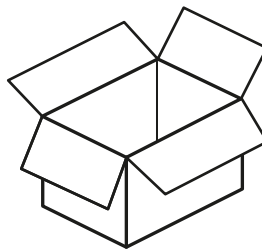

__ox

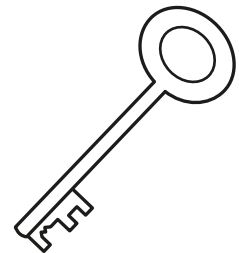

__ey

Circle the letter that makes the beginning sound of each picture's name.



m s

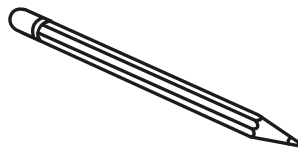

p r

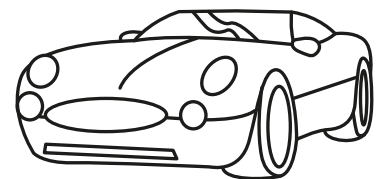

c a

Now write the words in alphabetical order.

.....

.....

.....



Ending Consonants

FACTS

Consonants can come at the end of words, too.

Read each word aloud and listen to its ending sound.
Circle the consonant at the end of each word.

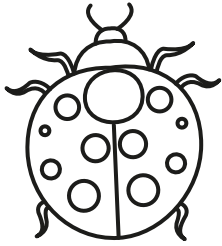

bug



sit

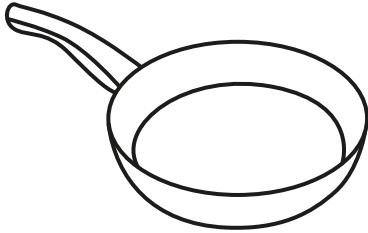

pan

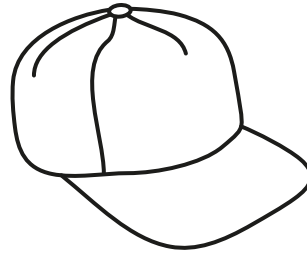

cap

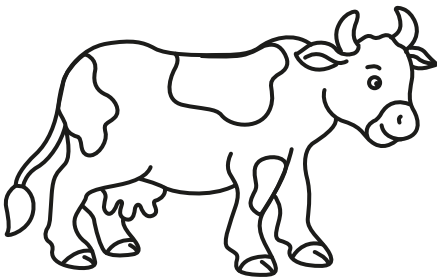

cow

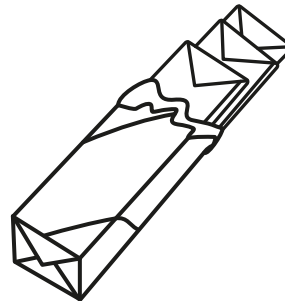

gum

Draw a picture of something whose name ends in the consonant **t**. Then write its name.

.....



Consonant blends are two or more consonants that come together to make one sound. Some consonant blends come at the beginning and others at the end of words. For example, say the word “glove.” Listen to the “gl” sound at the beginning.

Read the name of the first picture aloud. Listen to the beginning blend. Then circle the name of the picture with the same beginning sound.

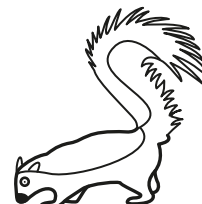
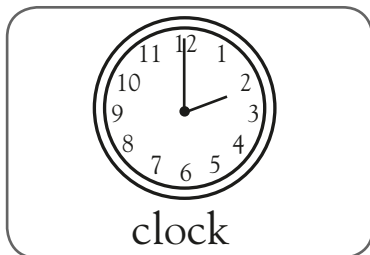
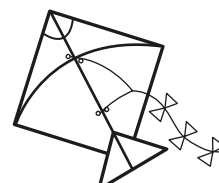
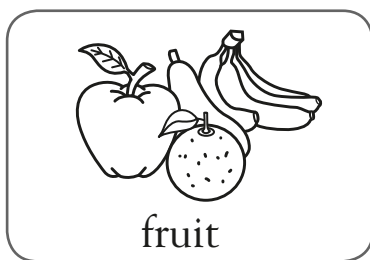

Read the name of the first picture aloud. Listen to the ending blend. Circle the name of the picture with the same ending sound.

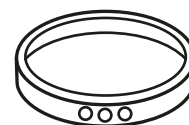
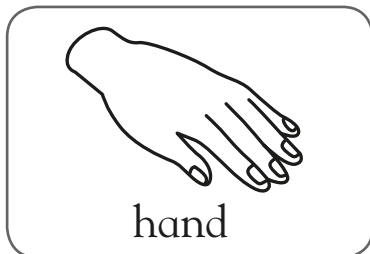
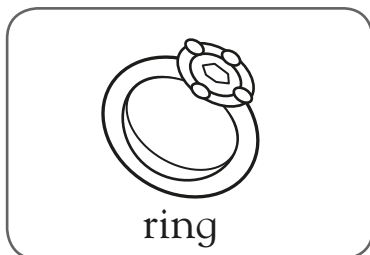



The Vowels

FACTS

The vowels in the alphabet are **a, e, i, o, u**, and sometimes **y**. We see vowels in the middle of many words.

Write the beginning letter of each picture's name in the box below it. The three letters form a word. Circle the letter in the word that is a vowel. Read the word aloud.

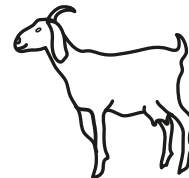
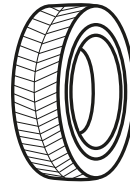
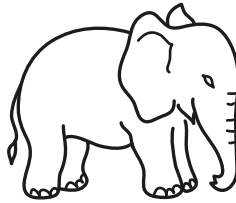
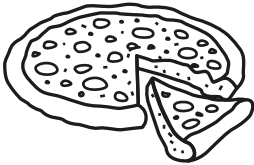
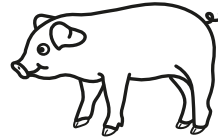

In the words below, move your finger over each letter and make its sound. Read the word aloud.



bag

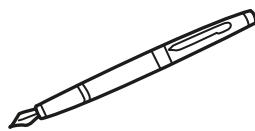

pen

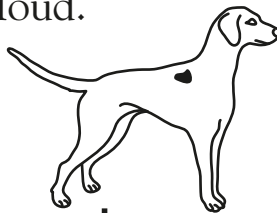

dog

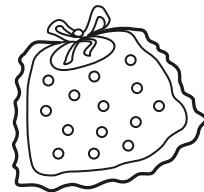

bib



The vowels **a**, **e**, **i**, **o**, and **u** each have a long sound and a short sound. When used as a vowel, **y** makes a long “i” sound or a long “e” sound.

Some vowels in the picture are missing.
Where in the world can they be?
Look at each word in the picture.
Write in its vowel, please!

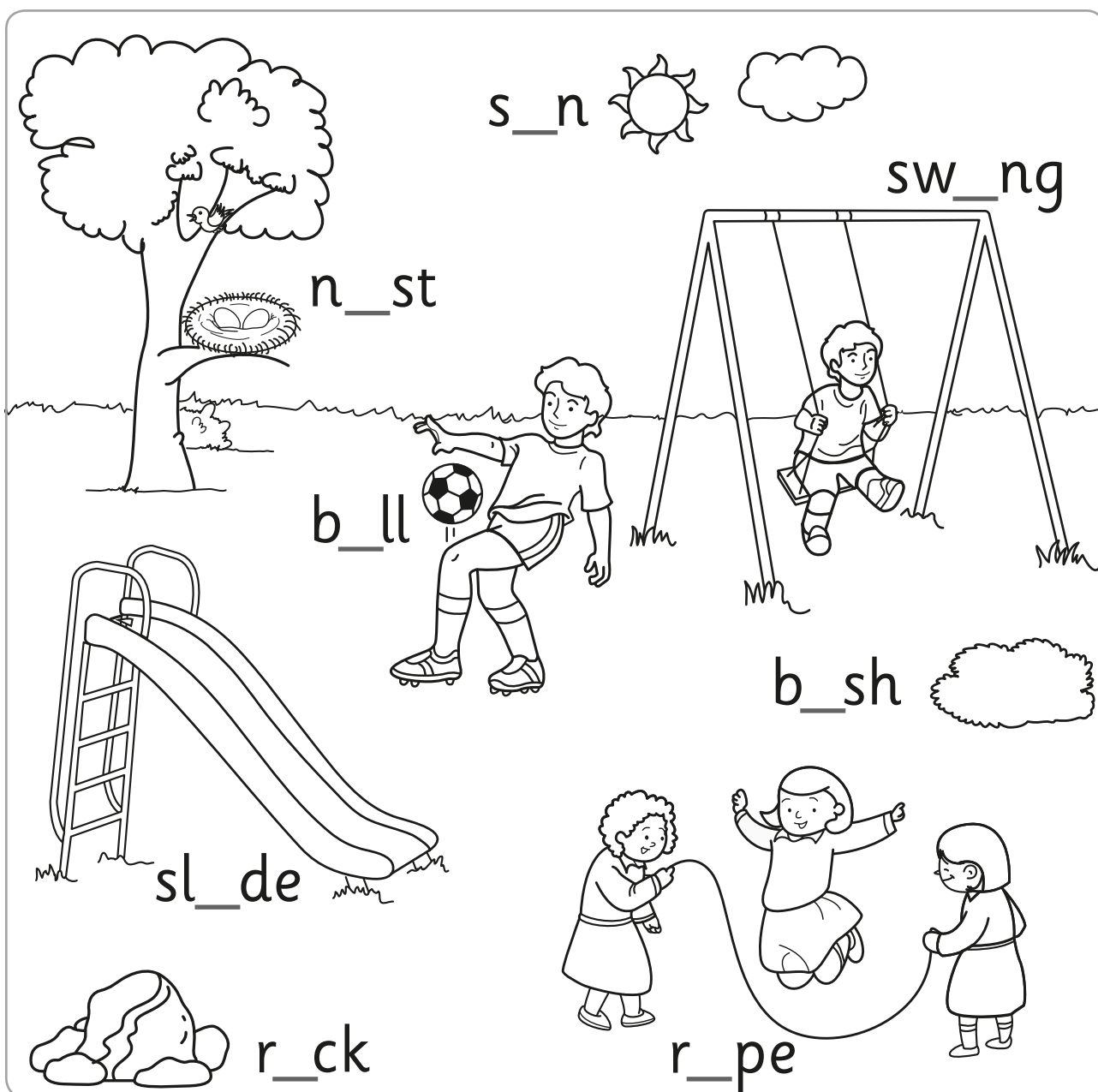



Beginning Consonant Blends

FACTS

A blend is two or more consonant sounds used together. Some blends come at the beginning of words. For example, say the word “frog” and listen to the sound of the “fr” blend.

Say the name of the first picture. Listen to the beginning blend. Circle the pictures that have names that begin with the same blend sound.

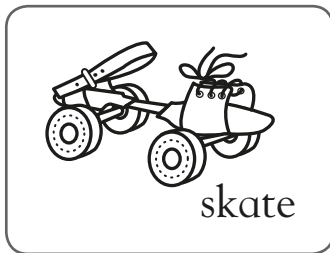
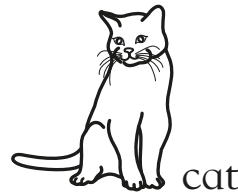
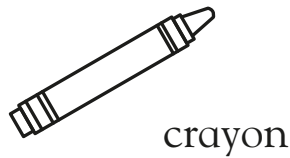
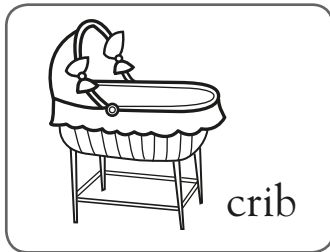
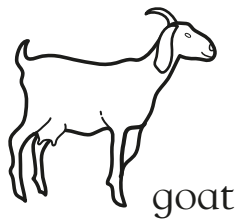
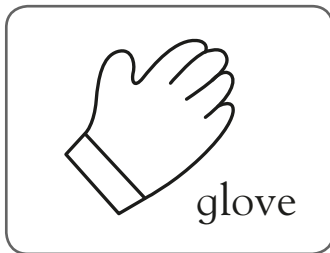

Say the name of each picture below. Circle the correct beginning blend.

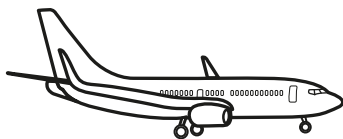

gl pl fl

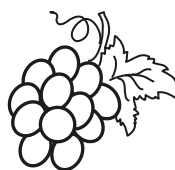

gr pr br



sq sk st

Ending Consonant Blends



Some consonant blends come at the end of words, such as in the word “jump.” Listen to the ending “mp” sound.

Write the correct consonant blend to finish each word.

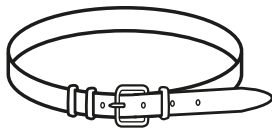

be__



ri__

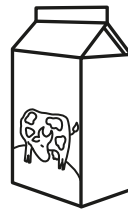

mi__

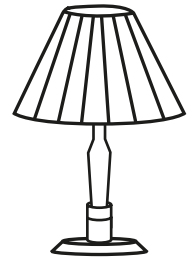

la__

Use a word from above to complete each sentence.

I have a in my bedroom.

He wore a brown with his pants.

I like to drink

I have a on my finger.

Draw a line from the ending consonant blend to the picture it matches.

ng

lf

nk

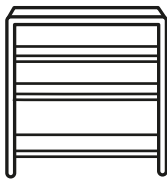

shelf



sink

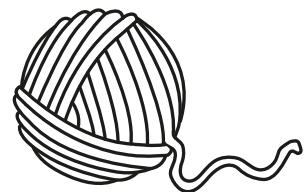

string



Digraphs at the Beginning

FACTS

Consonant digraphs are two letters that join to make one sound. For example, words like “**ch**ick,” “**th**irty,” “**sh**ip,” and “**wh**eel” have the consonant digraphs **ch**, **th**, **sh**, and **wh** at the beginning.

Look at each picture. Choose the correct beginning sound from the box to write under each picture.

ch

th

sh

wh



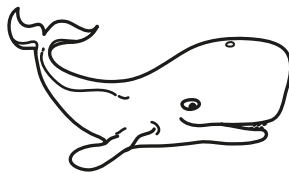



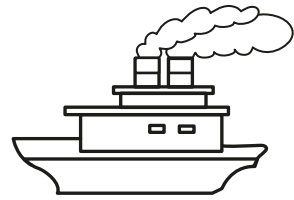



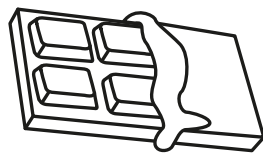

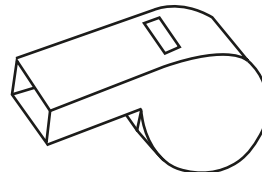

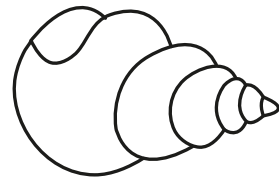

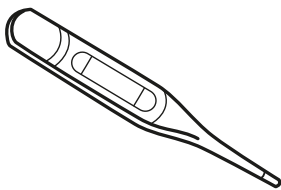

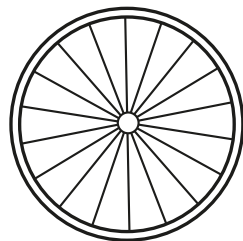



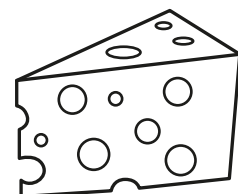

Digraphs at the End



Consonant digraphs can sometimes come at the end of words. For example, words like “sock,” “each,” “wish,” and “math” have the consonant digraphs **ck**, **ch**, **sh**, and **th** at the end.

Look at the pictures below. Choose the correct ending sound from the box to write under each picture.

sh

ch

ck

th

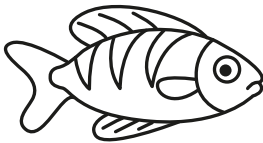



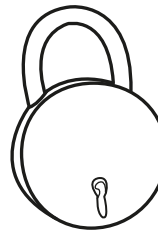



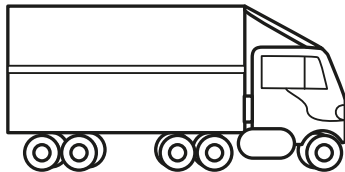

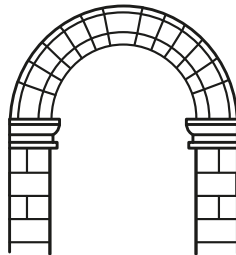

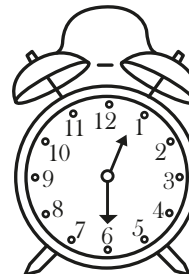

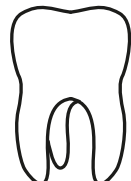

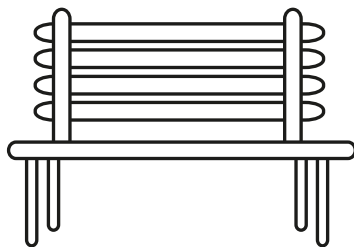

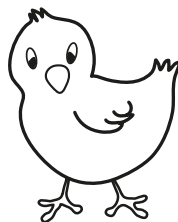

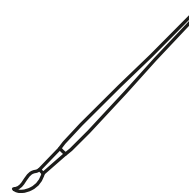





Sight Words

FACTS

Some words are so common that you will soon begin to recognize them instantly. These are called sight words. Many of them are not sounded out as they are spelled.

Look at the scrambled letters. Unscramble them to form a word from the box. Write each word and read it aloud.

most	of	are	the
put	one	been	two

eth

neo

owt

rea

tup

fo

nebe

msto

From the word box below, write the correct word for each word meaning.

different	great	four
-----------	-------	------

the word for 4

the opposite of same

a word for wonderful

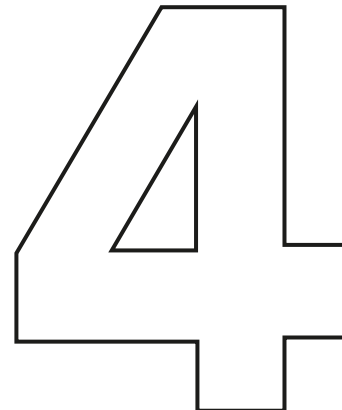



Sight words are also known as high-frequency words. Some more high-frequency words are “after,” “again,” “from,” “once,” and “thank.”

Read each word aloud. Write each word on the basket that shows its beginning letter.

some	what	do	often	they
would	old	where	does	their
should	school	thought	different	only

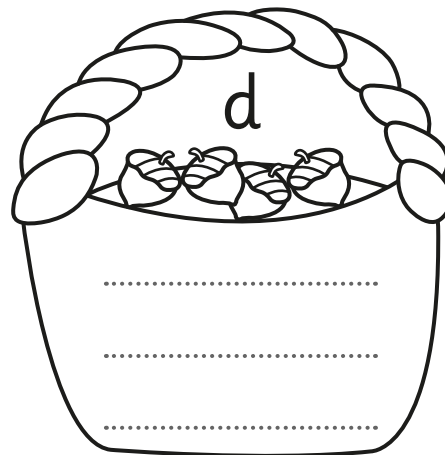
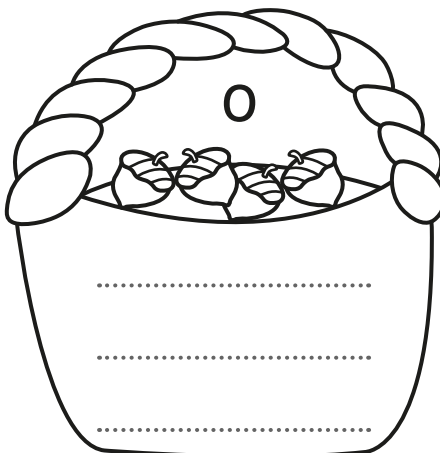
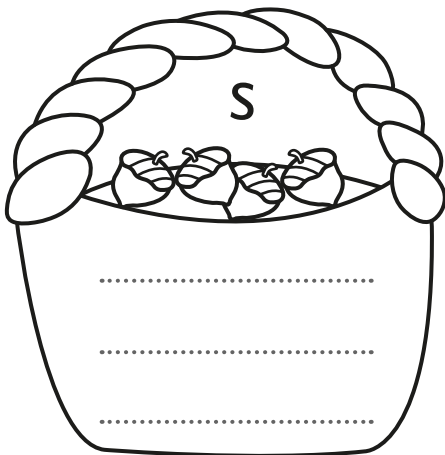
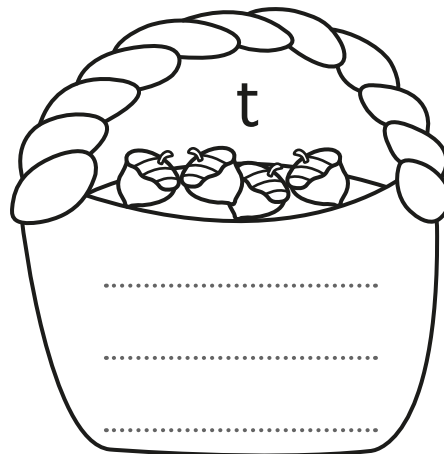
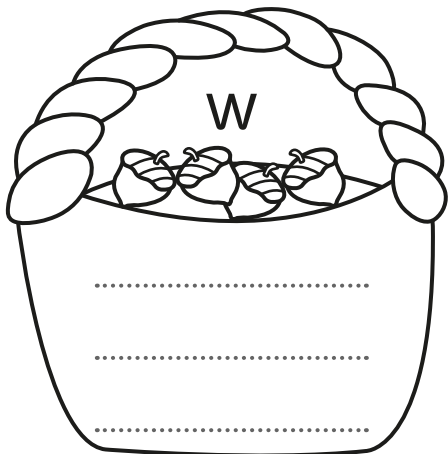



Pronouns are words that can take the place of nouns in a sentence.

Circle the pronoun in each sentence. Then write the pronoun.

My dog is small and fluffy.

.....

Where are you going?

.....

They went to the movies.

.....

Jane gave her a book.

.....

He needs new shoes.

.....

I like to bake cookies.

.....

We sang together.

.....

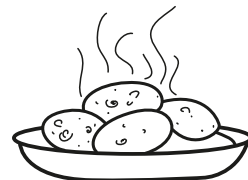
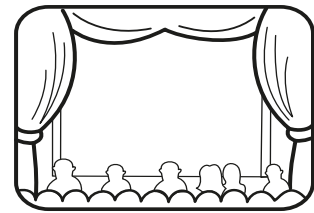
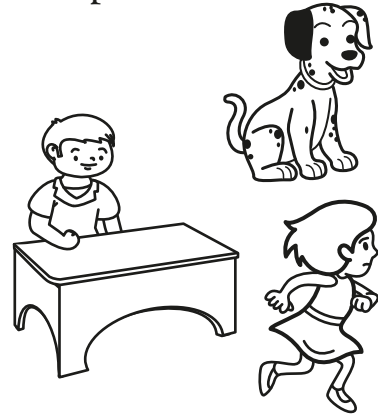



The most common pronouns are “he,” “she,” and “it.”

Find the pronoun from the word bank to replace the bold word in each sentence. Then write the word.

He

It

She

Jenny got into the car.

..... got into the car.

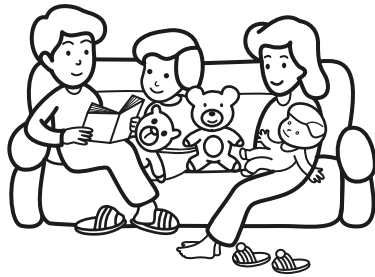
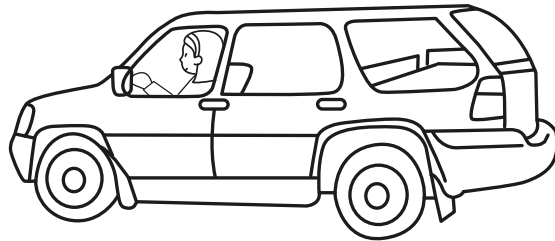

Mr. Brown told us a story.

..... told us a story.

The **star** shines brightly.

..... shines brightly.

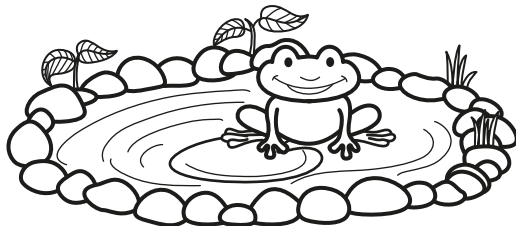
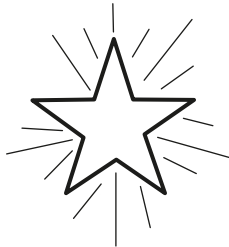

The **frog** hopped into the pond.

..... hopped into the pond.

My **aunt** made pizza.

..... made pizza.

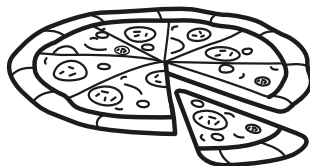



A verb is a word that names an action or a state of being.

Read each sentence aloud. Draw a line under the verb.

The skunk plays the horn.

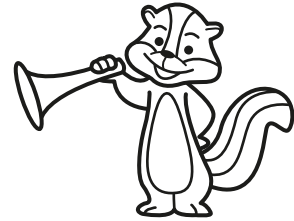

The fox dances.



The moose sings.



The bear listens.

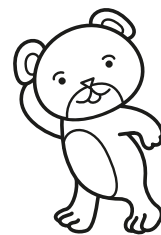

The raccoon claps.



The owl flies away.





Verbs in the present tense name an action that is happening now.

Read the sentences aloud. Pick the verb from the word bank that completes each sentence.

eat

rests

sinks

wait

whistle

The cat on the bed.

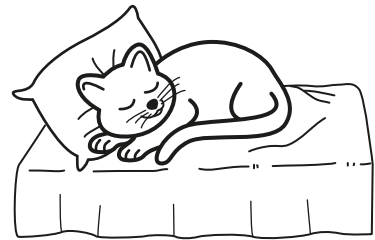

I my lunch.

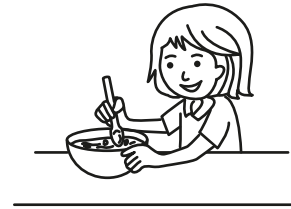

I can a tune.



We for the bus.

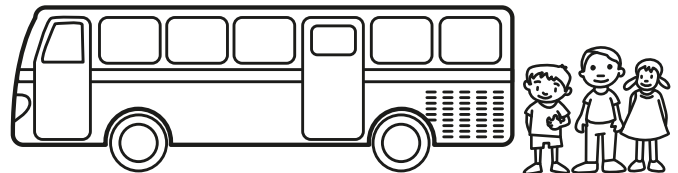

The rock to the bottom of the pond.





Past Tense

FACTS

Verbs in the past tense name an action that has already happened. Some verbs can be put in the past tense by adding **-ed** to the end.

Read the sentences aloud. Pick the verb from the word bank that completes each sentence.

baked

helped

planted

played

skated

Dear Grandma and Grandpa,

I had a busy day today! My mom and I

a cake. Then my dad and I seeds

in the garden. After that, my friend and I

at an ice-skating rink. I fell on the ice, but my friend

..... me up. Finally, we

video games until it was time to go home. I am

tired now!

Love,

Chris

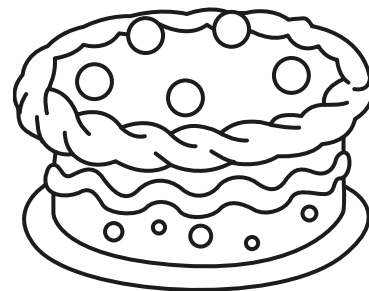



A verb is a word that names an action. Verbs in the future tense name an action that has not yet happened but will happen later.

Verbs in the future tense are usually paired with “will.”
Complete each sentence by writing the verb in the future tense.

Dad the car. (wash)

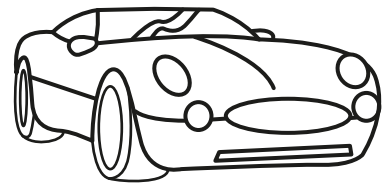

You dinner tonight. (cook)



We the bus to school tomorrow. (ride)



I you at the park at 3:00 p.m. (meet)



James his cousins next summer. (visit)

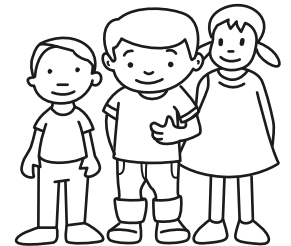

The chef salt to the soup if she needs to. (add)





Singular to Plural Nouns

Singular means one. Plural means more than one.

To make some words plural, add an **s** at the end of the word.
Add **es** to make a plural of a word that ends in **ch**, **sh**, **s**, or **x**.
Make these words plural.

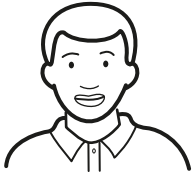

head__

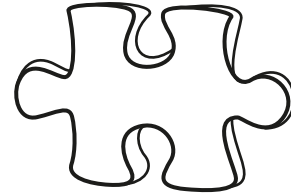

piece__

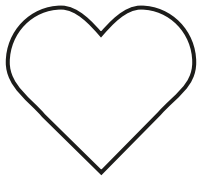

heart__



watch__



class__



school__

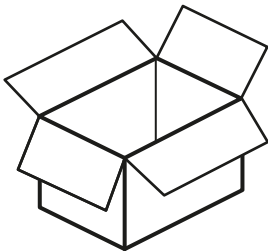

box__



wish__



Nouns and verbs combine to make sentences.

A verb that tells what a single person or thing does usually ends in s. Circle the correct verb to complete each sentence.

The rabbit dig digs a deep hole.

The acrobat flip flips through the air.

The wizard turn turns the elephant into a mouse.

Birds lay lays their eggs in a nest.

Authors write writes books.

The Earth spin spins on its axis.

A bagel taste tastes yummy with jelly.

The soccer players practice practices every day.



Is and Are

FACTS

The word “is” tells what one person or thing is doing now.
The word “are” tells what more than one person or thing is doing now.

Complete each sentence with “is” or “are.”

The cats having a party.

Joe Cat hanging balloons.

Moe Cat putting out food.

Zoe Cat and Roe Cat playing music.

Loe Cat dancing.

They having fun!





Verbs can have endings that tell when the action took place. The verb on its own is called a root word.

Read the pairs of sentences. Use **-ing** to complete the root word that describes something happening now. Use **-ed** to complete the root word that describes something that has already happened.

Dad is cook___ dinner.



Mom cook___ dinner last night.

I sew___ a button on my shirt last week.



It fell off, so I am sew___ it again.

We watch___ a movie in school this morning.

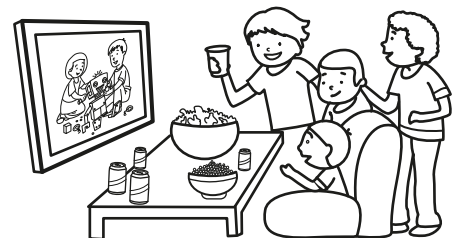

Now we are watch___ a movie at home.



Adjectives

FACTS

Adjectives are words that describe people, places, and things.

Pair each noun with an adjective from the word bank.
Then write a complete sentence using both words.
Finally, draw your characters in the woods.

Nouns

bear snake bird fox

Adjectives

colorful huge silly sleepy

.....

.....

.....

.....

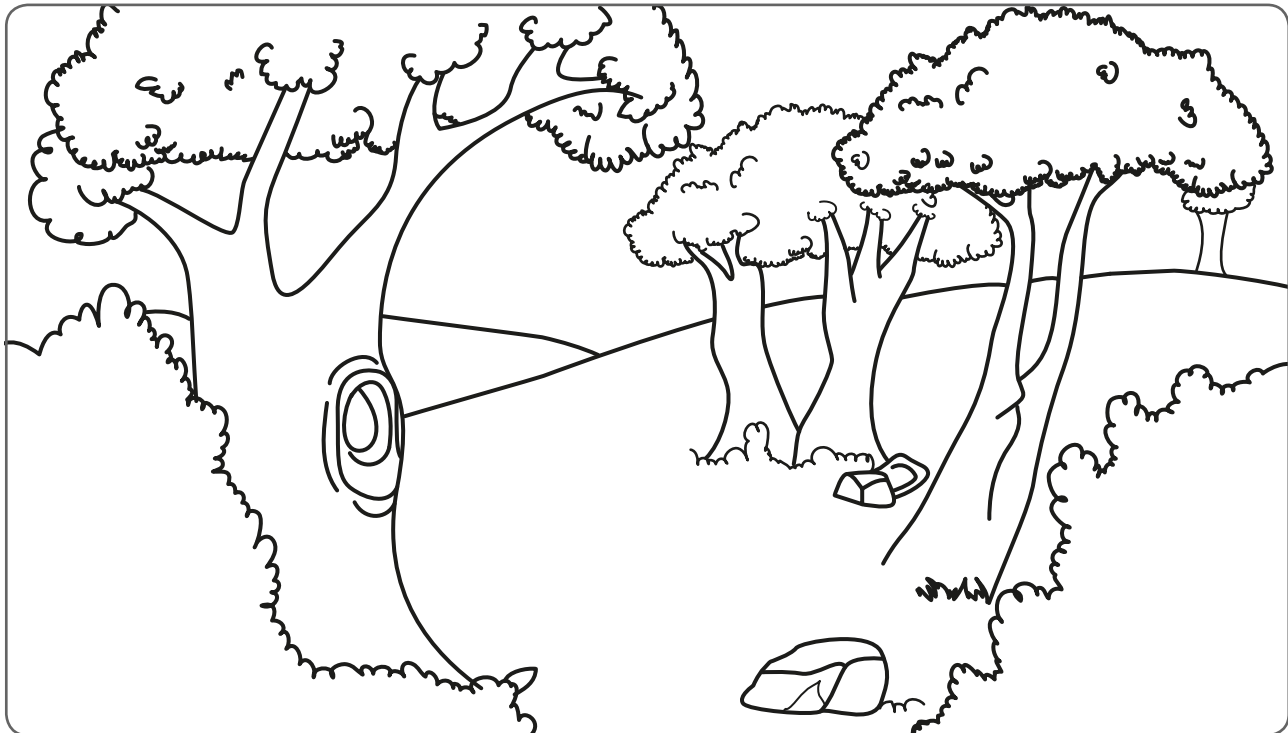



A preposition relates a noun or a pronoun to another word in the sentence.

Complete each sentence with a preposition from the word bank.

behind beside in on over under

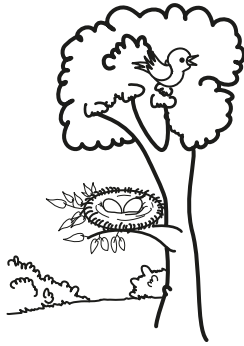

The bird is the tree.

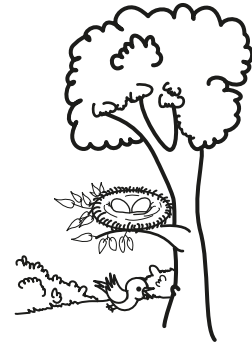

The bird is the tree.

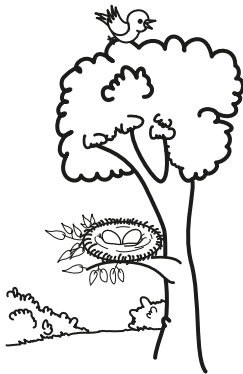

The bird is the tree.

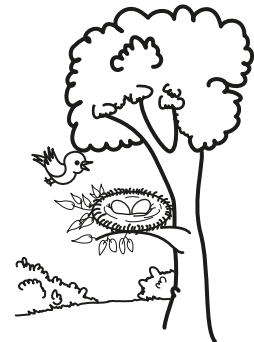

The bird is the tree.

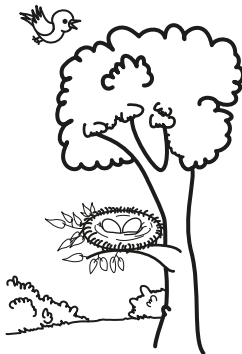

The bird is the tree.

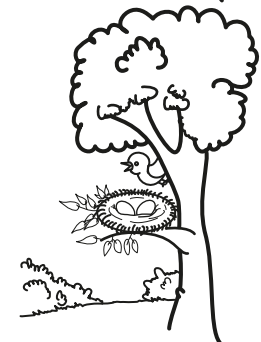

The bird is the tree.



Tens and Ones (Place Value)

GOAL

Learn about groups of tens and ones.



1 ten



3 ones

How many ladybugs are there? **Remember:** First count how many groups of ten there are, then count the ones that are left.



= tens and ones

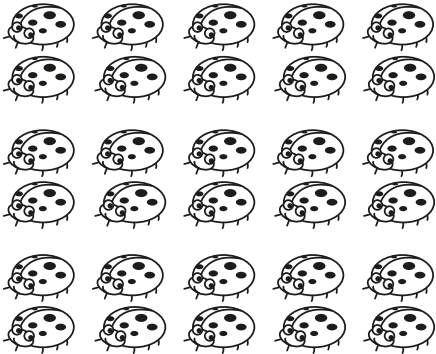

= tens and ones

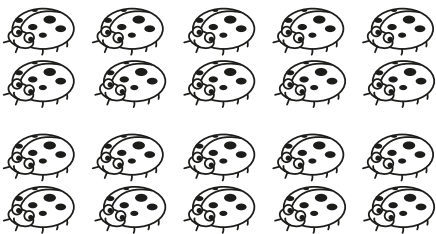

= tens and ones

How many ants are there?
Circle a group of ten,
then count the ants that
are left over. Write your
answer in terms of tens
and ones.



Tens	Ones

Finding Tens and Ones



GOAL

Learn to find groups of tens and ones.

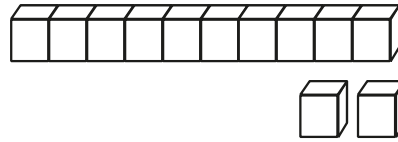

Tens	Ones	= 12
1	2	

For each problem, count the number of groups of ten blocks, and write that number under “tens.” Then count how many blocks are left, and write that number under “ones.” How many total blocks are there in each problem?

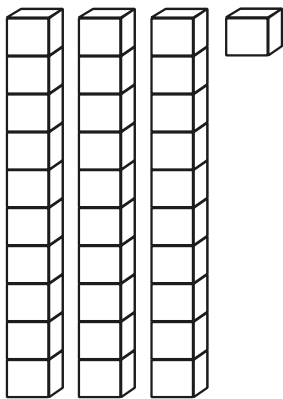

Tens	Ones	= <input type="text"/>
<input type="text"/>	<input type="text"/>	

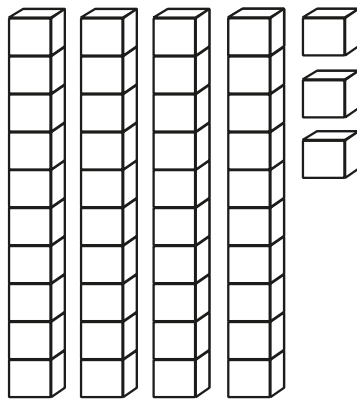

Tens	Ones	= <input type="text"/>
<input type="text"/>	<input type="text"/>	

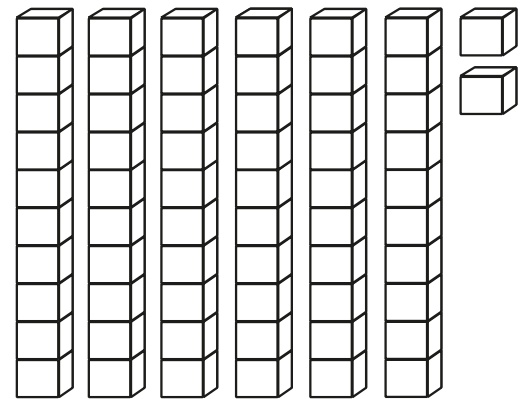

Tens	Ones	= <input type="text"/>
<input type="text"/>	<input type="text"/>	

Fill in the boxes and write the correct number.

	Tens	Ones	Number
2 tens and 8 ones =	<input type="text"/>	+ <input type="text"/>	= <input type="text"/>
9 tens and 4 ones =	<input type="text"/>	+ <input type="text"/>	= <input type="text"/>
3 tens and 6 ones =	<input type="text"/>	+ <input type="text"/>	= <input type="text"/>

Write these numbers as tens and ones.

20 = tens and ones

72 = tens and ones

35 = tens and ones

17 = tens and ones



Show One More

GOAL

Learn about adding one more to a number.



$5 + 1 = \boxed{6}$

In each row, first count the smiley faces, then draw one more. How many are there in each row now? Write the total number.

$4 \text{ smiley faces} + 1 = \boxed{}$

$2 \text{ smiley faces} + 1 = \boxed{}$

$1 \text{ smiley face} + 1 = \boxed{}$

Complete the chart.

Starting Number	Add One More	New Number
9	1	
6	1	
4	1	
5	1	

Add the two groups of hearts. Write the total in the box.

$7 \text{ hearts} + 1 \text{ heart} = \boxed{}$



Find out how to subtract one from a number.



Count the number of objects in each row. Then cross out one. How many are there now?

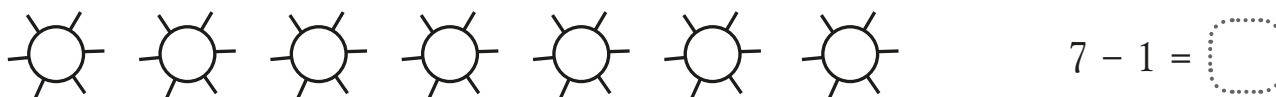

Look at the pictures in each column. Circle the picture that shows one less.

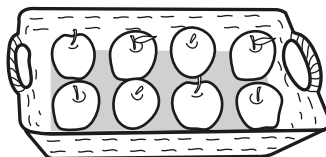
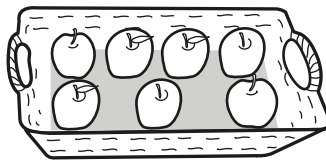
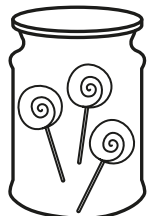
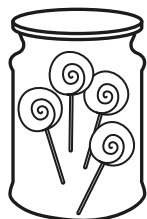

Subtract one from the group of stars below. Write the subtraction sentence.



- =



Find Ten More

GOAL

Learn to add ten to a number.

$3 \text{ add ten} = 13$

Look at the puzzle pieces. Add ten to each number on the left. Then draw a line from each puzzle piece on the left to its matching number + ten on the right.

Remember: The number on the right must be ten more than the number on the left.

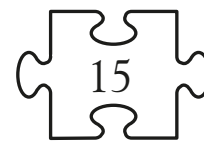
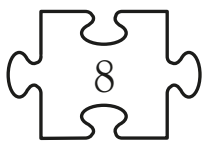
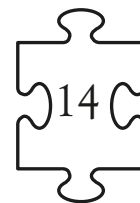
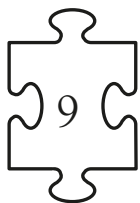
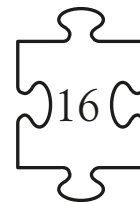
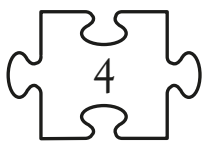
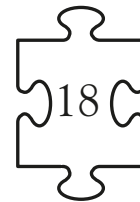
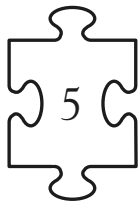
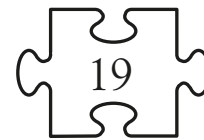
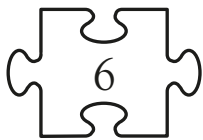

How many groups of ten are there in each number below?

Write the answer in the box.

12



35



26





Learn to subtract ten from a number.

15 subtract ten =

GOAL

Subtract ten from each number in the left column. Then write the subtraction sentence and the answer in the right column.

32 subtract ten

=

28 subtract ten

=

25 subtract ten

=

56 subtract ten

=

21 subtract ten

=

36 subtract ten

=

44 subtract ten

=

18 subtract ten

=

68 subtract ten

=

95 subtract ten

=

Finish the pattern. Write the number that is ten less each time.

50

40



10





Adding Up to 10

GOAL

Learn how to add up to 10.

$$\text{2 leaves} + \text{8 leaves} = \boxed{10}$$

Read the addition sentences in each row. Then color the flowers using two colors to show the addition sentence.

$6 + 4 = 10$



$8 + 2 = 10$



$7 + 3 = 10$



$2 + 8 = 10$



$3 + 7 = 10$



$4 + 6 = 10$



$9 + 1 = 10$



$5 + 5 = 10$



Complete these addition sentences by writing the missing number.

$4 + \boxed{} = 10$

$\boxed{} + 2 = 10$

$3 + 7 = \boxed{}$



Practice your addition skills.

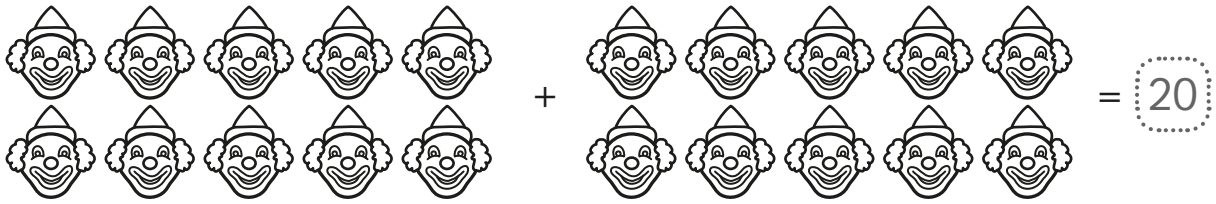

Help the clown reach the circus tent. First add each number sentence. Then follow the path of the number sentences with answers that are twenty or less.

$10 + 10 = \square$ $28 + 10 = \square$
 $8 + 11 = \square$ $10 + 40 = \square$
 $10 + 19 = \square$ $7 + 10 = \square$ $9 + 4 = \square$
 $30 + 10 = \square$ $5 + 6 = \square$
 $20 + 2 = \square$ $6 + 12 = \square$

Draw groups of clown hats to show this number sentence: $3 + 3 = 6$.

+ =



Subtraction from 0 to 10

GOAL

Learn how to subtract with numbers between 0 and 10.



$$5 - 3 = \boxed{2}$$

Look at the groups of fruit in each row. Then write the answer for each subtraction sentence.



$$7 - 3 = \boxed{}$$



$$9 - 6 = \boxed{}$$



$$8 - 4 = \boxed{}$$

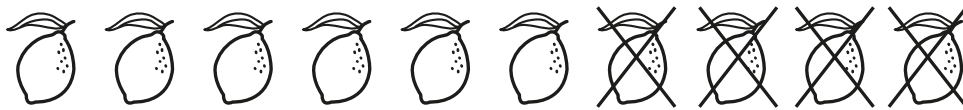

$$10 - 4 = \boxed{}$$

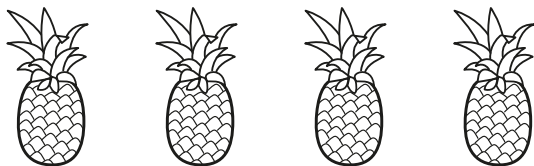

$$4 - 0 = \boxed{}$$

Joan counted six oranges in her bowl. She ate two.
How many oranges were left?

Write the number sentence.

$$\boxed{} - \boxed{} = \boxed{}$$

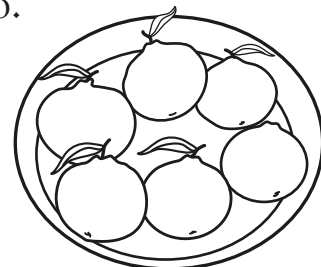



Practice your subtraction skills.



$$\begin{array}{r} 16 \\ - 6 \\ \hline 10 \end{array}$$

Subtract and write the answers in each row.

$$\begin{array}{r} 15 \\ - 4 \\ \hline \end{array}$$

$$\begin{array}{r} 29 \\ - 6 \\ \hline \end{array}$$

$$\begin{array}{r} 18 \\ - 5 \\ \hline \end{array}$$

$$\begin{array}{r} 16 \\ - 4 \\ \hline \end{array}$$

$$\begin{array}{r} 12 \\ - 2 \\ \hline \end{array}$$

$$\begin{array}{r} 19 \\ - 3 \\ \hline \end{array}$$

$$\begin{array}{r} 10 \\ - 7 \\ \hline \end{array}$$

$$\begin{array}{r} 9 \\ - 5 \\ \hline \end{array}$$

$$\begin{array}{r} 39 \\ - 4 \\ \hline \end{array}$$

$$\begin{array}{r} 20 \\ - 10 \\ \hline \end{array}$$

$$\begin{array}{r} 16 \\ - 8 \\ \hline \end{array}$$

$$\begin{array}{r} 56 \\ - 6 \\ \hline \end{array}$$

$$\begin{array}{r} 14 \\ - 7 \\ \hline \end{array}$$

$$\begin{array}{r} 9 \\ - 6 \\ \hline \end{array}$$

$$\begin{array}{r} 60 \\ - 30 \\ \hline \end{array}$$

$$\begin{array}{r} 89 \\ - 9 \\ \hline \end{array}$$

$$\begin{array}{r} 18 \\ - 15 \\ \hline \end{array}$$

$$\begin{array}{r} 58 \\ - 8 \\ \hline \end{array}$$

Read each story. Then write the answer for each subtraction problem.

Juan had thirteen crayons.
He broke two crayons. How many
of his crayons were not broken?

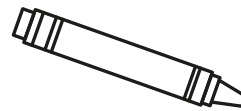

$$13 - 2 = \square$$



We saw twenty-five bunnies.
Four bunnies ran away.
How many bunnies were left?

$$25 - 4 = \square$$

Jen made nineteen cupcakes.
She gave away six cupcakes.
How many cupcakes were left?



$$19 - 6 = \square$$



Recognizing Money

GOAL

Learn the names of coins.



Penny



Nickel



Dime



Quarter

Follow the directions in each section.

Circle four pennies.



Circle three nickels.

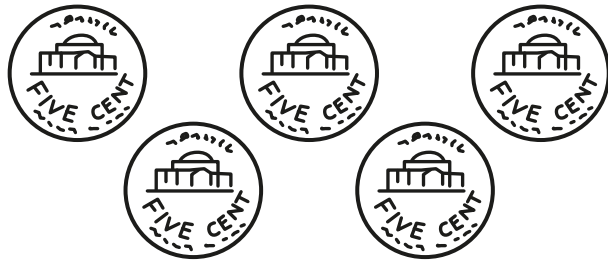

Circle five dimes.

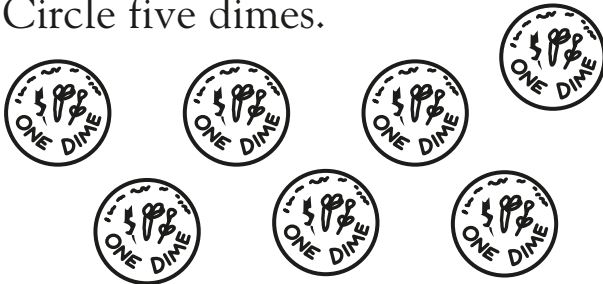

Circle two quarters.

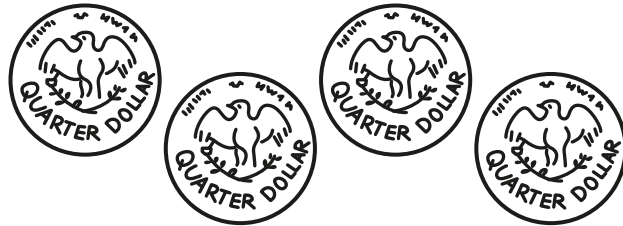

Circle two pennies and one nickel.

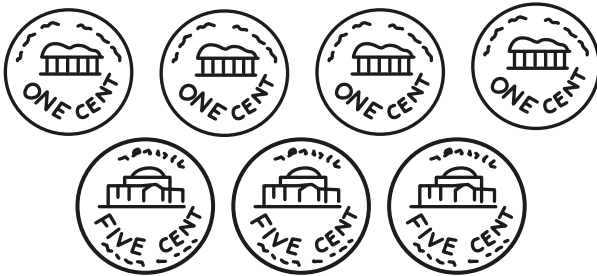

Circle three dimes and one quarter.



Read the amount of cents. Circle the coins that make each amount.

10¢ =



15¢ =





Practice adding money.

$$\begin{array}{r} 25\text{¢} \\ + 12\text{¢} \\ \hline 37\text{¢} \end{array}$$

Add the amounts of money in each row.

$$\begin{array}{r} 30\text{¢} \\ + 12\text{¢} \\ \hline \end{array}$$

$$\begin{array}{r} 17\text{¢} \\ + 22\text{¢} \\ \hline \end{array}$$

$$\begin{array}{r} 33\text{¢} \\ + 25\text{¢} \\ \hline \end{array}$$

$$\begin{array}{r} 37\text{¢} \\ + 30\text{¢} \\ \hline \end{array}$$

$$\begin{array}{r} 14\text{¢} \\ + 10\text{¢} \\ \hline \end{array}$$

$$\begin{array}{r} 50\text{¢} \\ + 30\text{¢} \\ \hline \end{array}$$

$$\begin{array}{r} 27\text{¢} \\ + 61\text{¢} \\ \hline \end{array}$$

$$\begin{array}{r} 17\text{¢} \\ + 21\text{¢} \\ \hline \end{array}$$

$$\begin{array}{r} 35\text{¢} \\ + 13\text{¢} \\ \hline \end{array}$$

$$\begin{array}{r} 32\text{¢} \\ + 17\text{¢} \\ \hline \end{array}$$

$$\begin{array}{r} 21\text{¢} \\ + 50\text{¢} \\ \hline \end{array}$$

$$\begin{array}{r} 16\text{¢} \\ + 11\text{¢} \\ \hline \end{array}$$

$$\begin{array}{r} 30\text{¢} \\ + 24\text{¢} \\ \hline \end{array}$$

$$\begin{array}{r} 23\text{¢} \\ + 22\text{¢} \\ \hline \end{array}$$

$$\begin{array}{r} 18\text{¢} \\ + 20\text{¢} \\ \hline \end{array}$$

$$\begin{array}{r} 33\text{¢} \\ + 12\text{¢} \\ \hline \end{array}$$

$$\begin{array}{r} 25\text{¢} \\ + 22\text{¢} \\ \hline \end{array}$$

$$\begin{array}{r} 40\text{¢} \\ + 23\text{¢} \\ \hline \end{array}$$

$$\begin{array}{r} 23\text{¢} \\ + 60\text{¢} \\ \hline \end{array}$$

$$\begin{array}{r} 16\text{¢} \\ + 12\text{¢} \\ \hline \end{array}$$

Look at each group of coins. Circle the one with the most money.

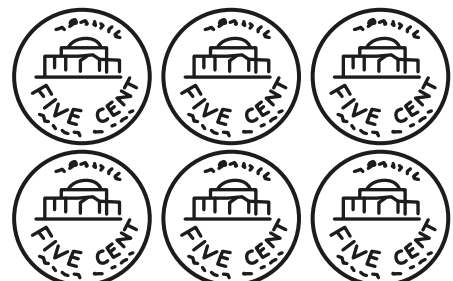
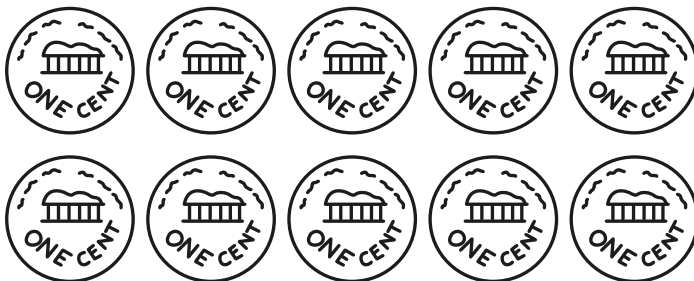



Double Trouble

GOAL

Learn to double amounts.

$$5\text{¢} + 5\text{¢} = 10\text{¢}$$

$$\begin{array}{r} 4\text{¢} \\ + 4\text{¢} \\ \hline 8\text{¢} \end{array}$$

Look at the coins on the left, then draw the coins you need to double each amount. Add to find the total amount in each row.

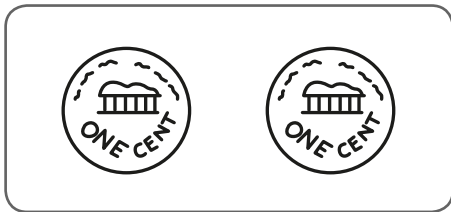

+



=

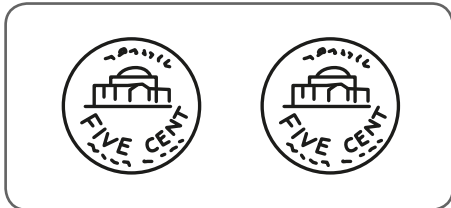

+



=



+



=



Write the answer to each addition problem.

Circle the equations that show doubled amounts.

$8\text{¢} + 1\text{¢} = \square \quad 5\text{¢} + 2\text{¢} = \square \quad 5\text{¢} + 5\text{¢} = \square \quad 9\text{¢} + 8\text{¢} = \square$

$9\text{¢} + 2\text{¢} = \square \quad 5\text{¢} + 4\text{¢} = \square \quad 6\text{¢} + 3\text{¢} = \square \quad 7\text{¢} + 7\text{¢} = \square$

Pam had four apples. Dan bought four peaches. How many pieces of fruit did they have in all?

Write the number sentence. $\square + \square = \square$

Is the answer a double?



Find the coins you need to use when buying an item.

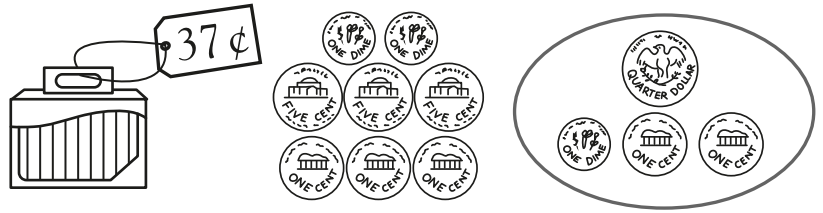

Look at the prices of the items. Circle the coins required to buy the item in each row.

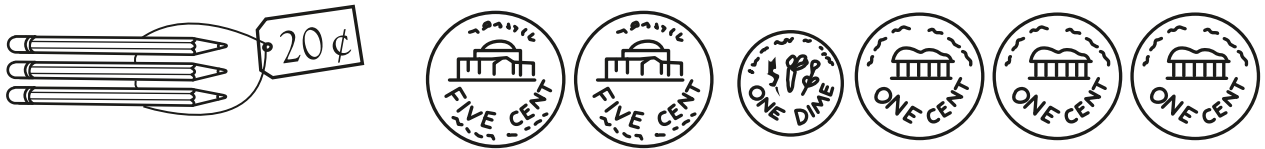

Draw a line to match the treat with the coins you need to buy it.





Figuring Out Change

GOAL

Learn about getting back change.

You have



You buy



Will you get change?

Yes

No

Count how much money you have, and write the amount in the box. Look at the price of what you buy. Figure out if you will get change, and circle "yes" or "no."

You have



You buy

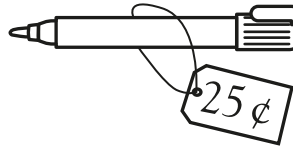

Will you get change?

Yes

No

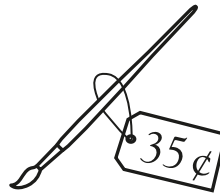

Yes

No

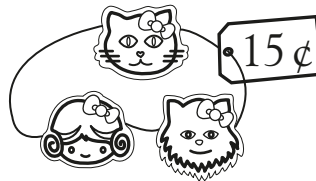

Yes

No

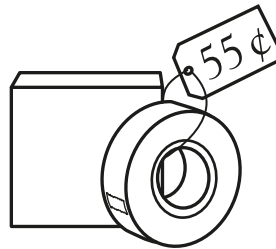

Yes

No

Jon has 35¢. He buys a toy truck for 24¢.

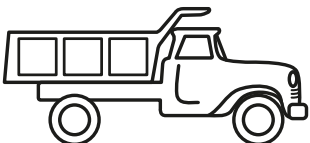

How much change will John get back?



Learn how to calculate change using subtraction.

I have 20¢. I buy one apple.  I will get 5¢ change.

Read each problem, and write the answer in the last column.

I have

I buy

I will get this much change.

50¢

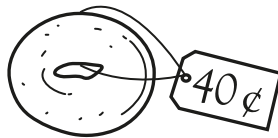

70¢

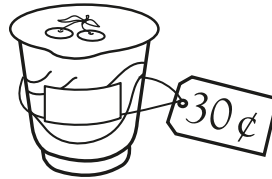

Look at the prices of snacks given below. Then write the subtraction sentence and answer for each of the problems.

yogurt 30¢

bagel 40¢

bag of pretzels 35¢

Sara has 50¢. She buys a container of yogurt from Mr. Jones. How much change should Mr. Jones give Sara?



Jill has 50¢. She buys a bagel from Mr. Jones. How much change should Mr. Jones give Jill?



Sei has 75¢. She buys a bag of pretzels from Mr. Jones. How much change should Mr. Jones give Sei?





Telling the Time: O'Clock

GOAL

Learn to tell what time it is. This clock shows 2 o'clock.

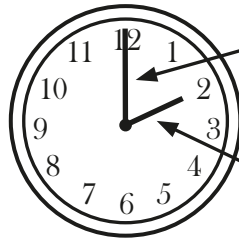

The minute hand moves as the minutes go by.

The hour hand points to the hour of day.

Fill in the number to tell what time each clock shows.

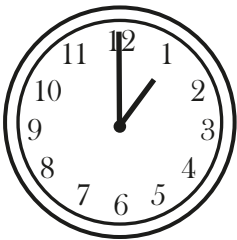

o'clock

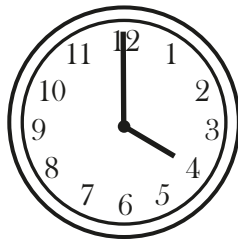

o'clock

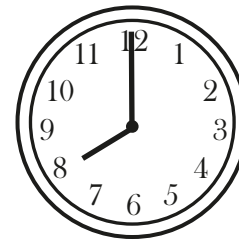

o'clock

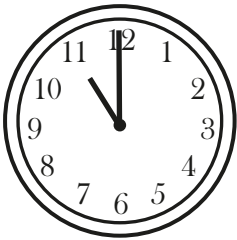

o'clock

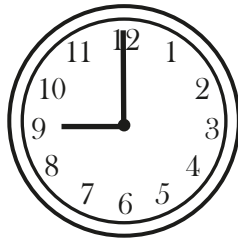

o'clock

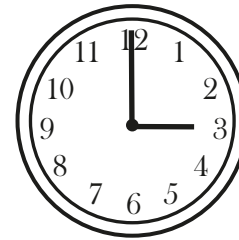

o'clock

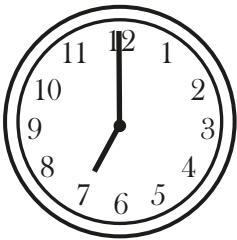

o'clock

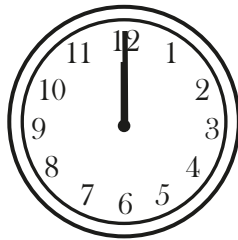

o'clock

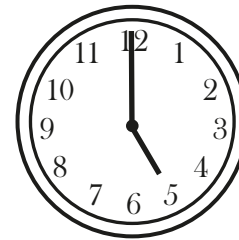

o'clock

Fill in the correct numbers in the sentence below.

At 3 o'clock, the minute hand points to and the hour hand points to .

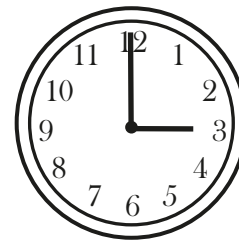



Learn to tell the time to the half hour.
 "Half past" means that it is
 30 minutes past the hour.
 When you say "half past one," it is
 the same as saying "one thirty."

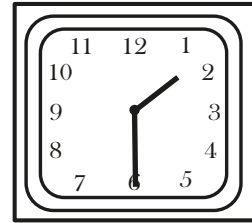

1:30

One thirty.

Write the correct time for each clock in numbers and in words.

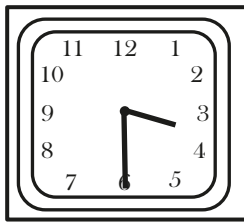

○ : ○

..... thirty

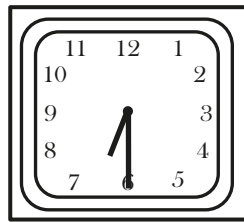

○ : ○

..... thirty

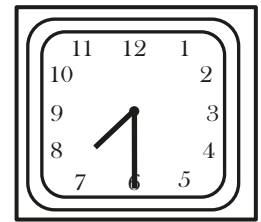

○ : ○

..... thirty

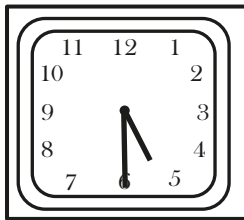

○ : ○

..... thirty

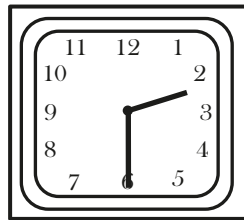

○ : ○

..... thirty

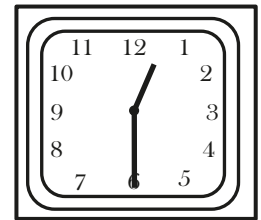

○ : ○

..... thirty

Write the missing numbers
 on the clock. Then complete
 the sentence.

It is half past

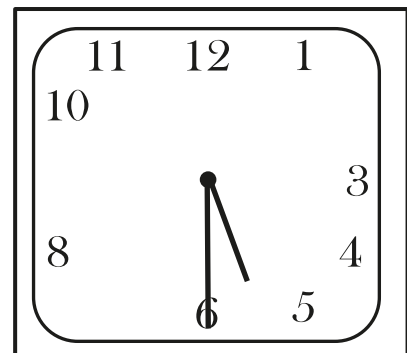



Writing the Time: O'Clock

GOAL

Practice using the word *o'clock*.

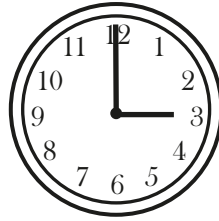

...3 o'clock...

Look at each clock. Write the time each clock shows.

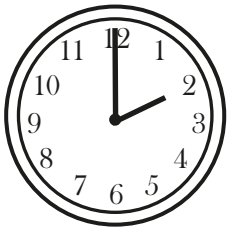

.....

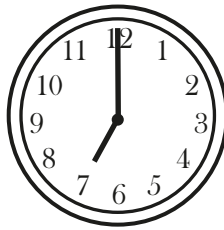

.....

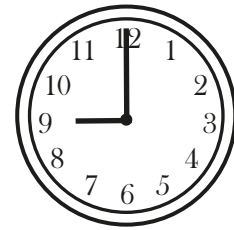

.....

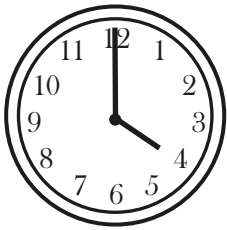

.....

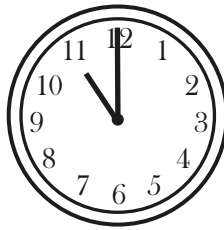

.....

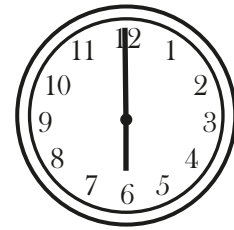

.....

Draw the hands on the clock to show the correct time.

5 o'clock

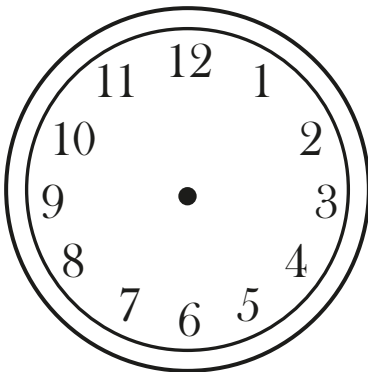

1 o'clock

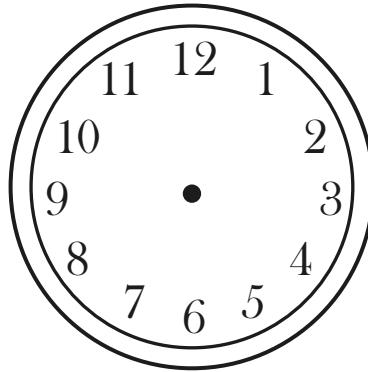

12 o'clock

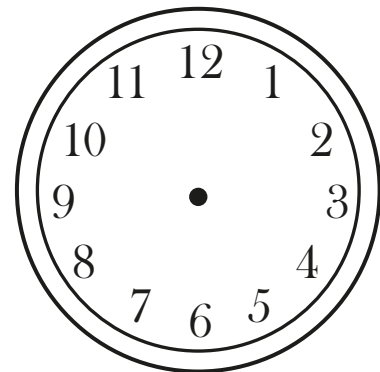

Writing the Time: Digital



GOAL

Learn how to write the time on a digital clock.

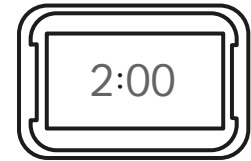
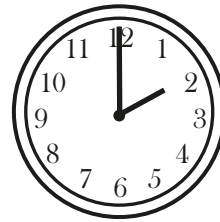

Write the time shown on the left onto the digital clock on the right.

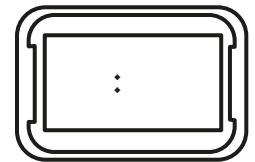
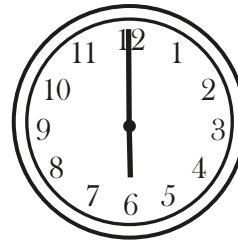
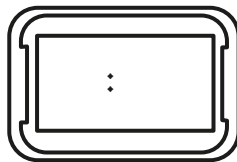
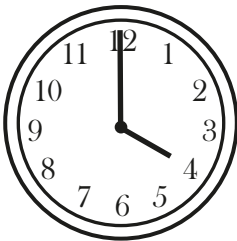

Write the time shown onto the digital clock face.

8 o'clock

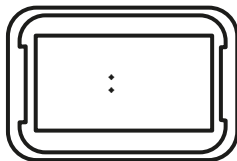

six thirty

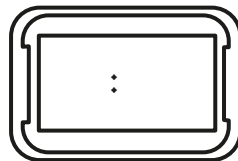

10 o'clock

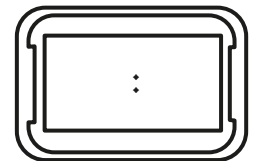

Show half past ten, or ten thirty, on both the clocks.

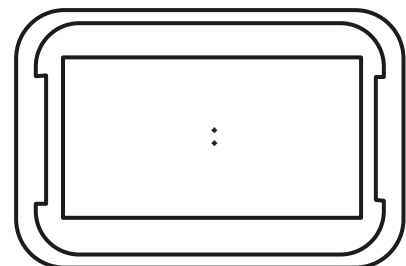
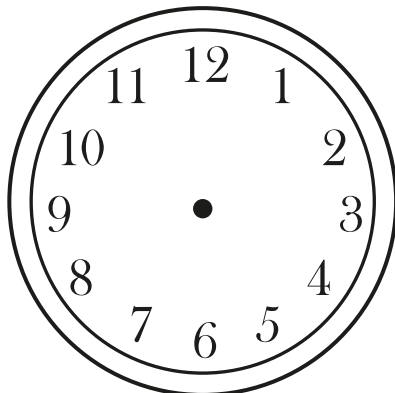



Using Clocks

GOAL

Practice using clocks.

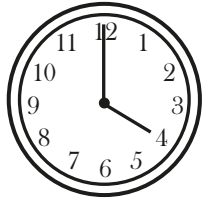

Jamie eats dinner at 5 o'clock.

Is it time for her to eat dinner?

Yes

No

Circle "yes" or "no" to answer the questions below.

John starts school at 9 o'clock. Does the clock show it is time for John to start school?

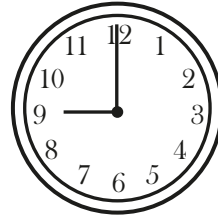

Yes

No

Look at the time on the clock. It is time for math. Does math start at 10:00?

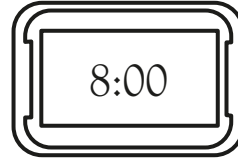

Yes

No

Look at the clock. Reading starts in 1 hour. At what time will reading start?

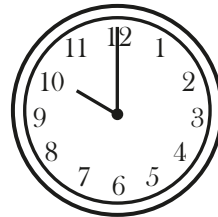

Sam and his mom went to the store. They left for the store at 4 o'clock. They arrived back at home at 5 o'clock.

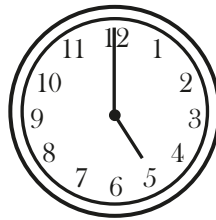
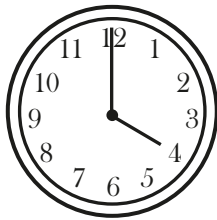

How long were Sam and his mother gone?

1 minute

1 hour

Look at the clock on the right. Lunch will start in half an hour. What time will lunch start?

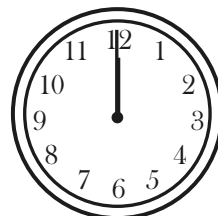



Learn about how long it takes to do some activities.

The activity circled here takes more time than the other.

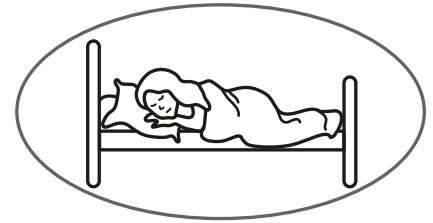

Circle the activity in each group below that takes more time.

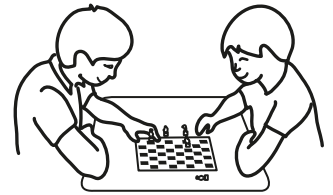

Circle the activity in each group below that takes less time.

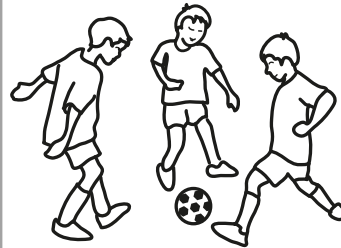

About how long does each activity take? Circle the best answer.

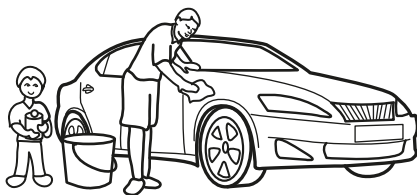

1 minute 1 hour



1 minute 1 hour

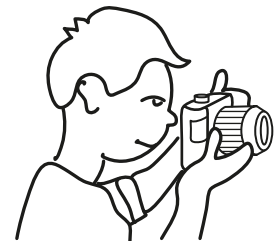

1 minute 1 hour



Days of the Week

GOAL

Learn about the days in each week.

These are the names of the seven days of the week in order:



Circle the correct answer for each question below.

Which is the first day of the week? Sunday Saturday

Which day comes before Wednesday? Friday Tuesday

Which day comes after Sunday? Monday Wednesday

Which day comes after Friday? Tuesday Saturday

July

Sunday	Monday	Tuesday	Wednesday	Thursday	Friday	Saturday
	1	2	3	4	5	6
7	8	9	10	11	12	13
14	15	16	17	18	19	20
☾ 21	22	23	24	25	26	27
28	29	30	31			

Use the calendar above to answer each question. Circle your answers.

What day of the week is numbered 1? Thursday Monday

What is the second Tuesday numbered? 9 16

Which date shows a ☾? 12 21

How many days are there in this month? 28 31

How many Sundays are there in this month? 4 5



Learn about the months of the year.

January 31 days	February 28 days	March 31 days	April 30 days
May 31 days	June 30 days	July 31 days	August 31 days
September 30 days	October 31 days	November 30 days	December 31 days

Use the information above to answer each question.

Which month comes after January?

.....

Which is the month with the fewest days?

.....

How many months begin with the letter J?

How many months have 30 days?

How many months have 31 days?

Which month comes between July and September?

.....

Which month comes before June?

.....

In the chart above, circle the month of your birthday.

Write the month of your birthday here.

How old are you? years



Muscles are stretchy tissues that are attached to the bones. When muscles work, they pull on the bones making them move.

TEST What You Need:

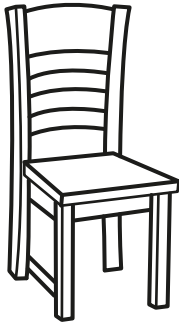

Chair



What To Do:

1. Sit on the chair. Put both hands around the top of one of your legs.
2. Flex your knee, lifting up the lower part of your leg.
3. Draw an arrow on the picture below, pointing to where you can feel the muscles move and change shape as your leg moves.
4. Stand up. Hold one arm out straight to the side and touch your upper arm.
5. Flex your elbow, lifting up your lower arm.
6. Draw an arrow on the picture below, pointing to where the muscles move and change shape as your lower arm moves.

RESULT



What do you notice about the way your muscles change as you raise your lower leg or arm?

.....





Bones support and protect the body.

Read the words in the box. Use them to fill in the blanks around the skeleton below.

Elbow

Knee

Skull

Wrist

The is where the bones of the upper arm and the lower arm meet.

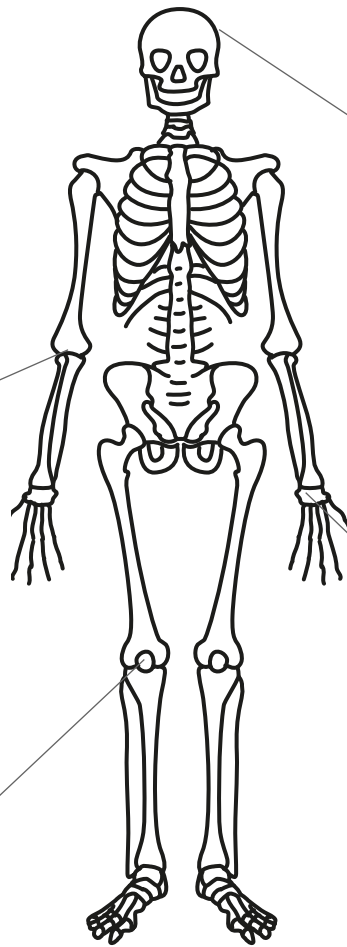

The is the bone in the head that protects the brain.

The is where the bones of the upper leg and the lower leg meet.

The is the part of the body where the bones of the lower arm and the hand meet.

Touch your head. Can you feel your skull? Circle the word that describes how it feels.

Soft

Hard





The Organs

FACTS

An organ is a part of the body that does a special job to help keep you alive. The heart, lungs, stomach, and brain are major organs. The heart pumps blood around the body. The stomach digests food. The lungs absorb oxygen from the air you breathe. The brain is the body's control center.

Use the words in the box to write the labels for the drawing below.

Brain

Heart

Lungs

Stomach

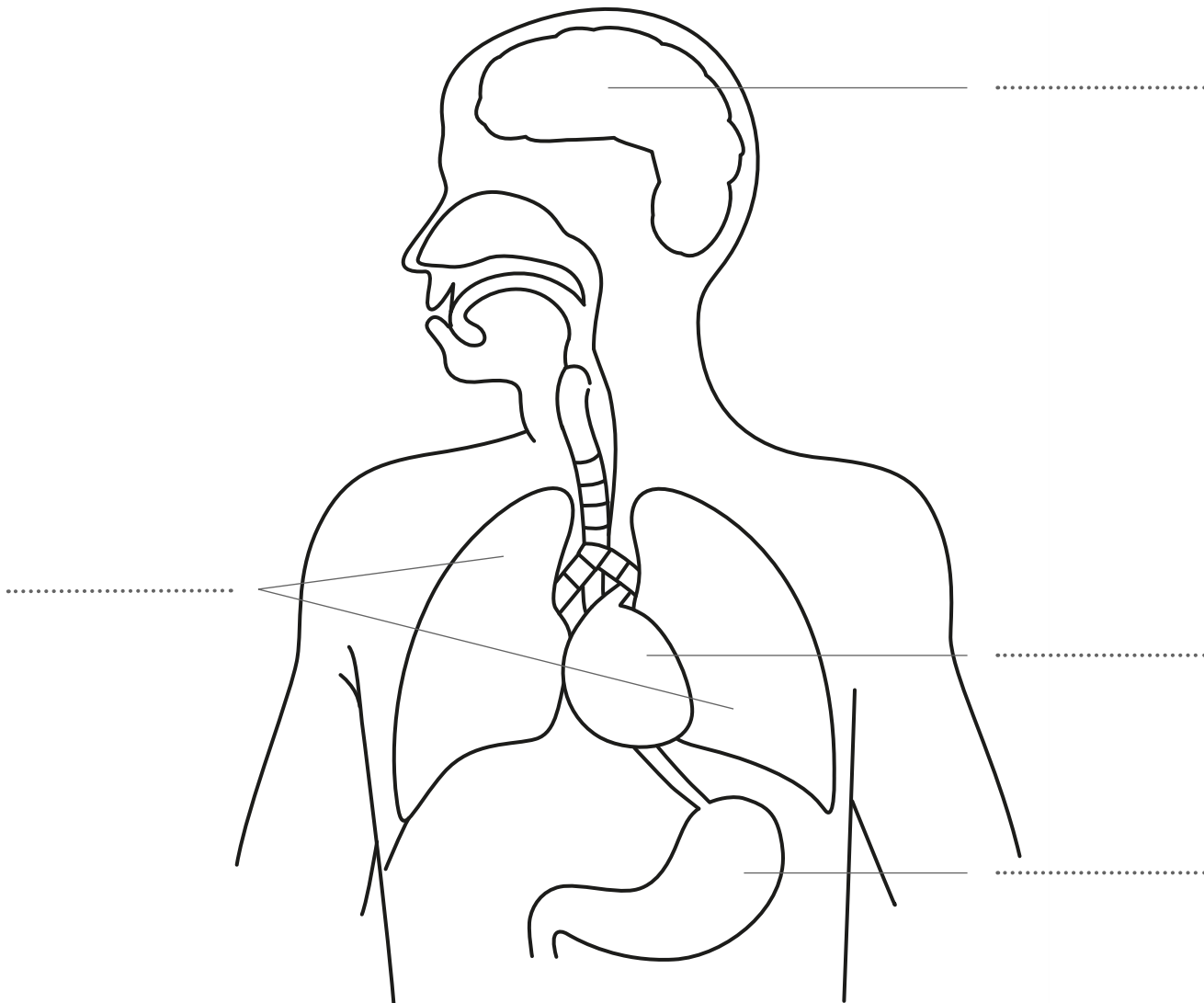



The heart pumps blood around the body. The blood travels in tubes called arteries and veins. Arteries open and close as blood passes through them. If arteries are near the surface of the skin, you can feel them opening and closing. This is called the pulse. How fast your pulse beats, tells you how fast your heart is beating.

TEST What You Need:

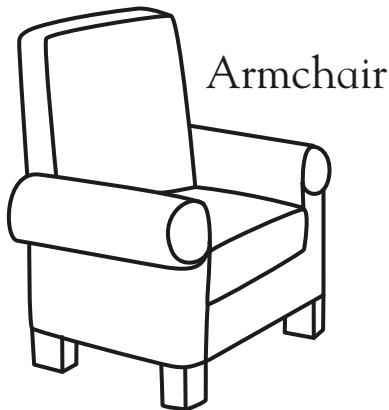

2. Sit down on the chair and relax for a few minutes. Find your pulse again. Record whether it is faster or slower than when you were standing.
3. Walk around for a few minutes, then find your pulse again. Record whether it is faster or slower than when you were sitting.
4. Run around for a few minutes, then find your pulse once more. Record whether it is faster or slower than when you were walking.



What To Do:

1. Stand still for about a minute, then find your pulse by placing your fingers on the side of your neck, just underneath your jaw.

RESULT Study the results you have recorded for each activity.

Activity	Faster or Slower Pulse
Sitting down	
Walking	
Running	

What do you notice about your results?

.....

.....

.....



Matter

FACTS

Matter is the name used to describe all the different materials that make up the universe. All matter exists as a solid, liquid, or gas. A solid keeps its shape. A liquid flows, and takes the shape of the container it is in. A gas will also flow and expand and fill the container that it is in.

Answer the questions on the chart by writing **Yes** or **No** under the name of each substance named at the top of the chart. Then answer the questions under the chart.

Material	Water	Air	Penny
Will it flow?			
Does it keep its shape?			
Will it spread to fill a container?			

1. Which material is a solid?

2. Which material is a liquid?

3. Which material is a gas?





Solids do not change shape by themselves. They will not pour or spread out to fill a space.

Look at the materials shown below. Put a check (✓) in the box next to the name of each one if you think it is a solid.

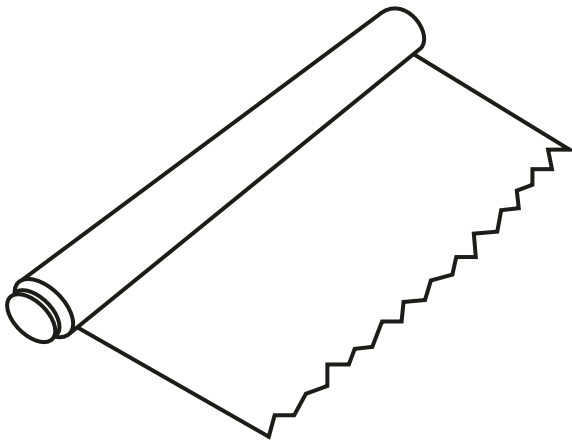

Aluminum foil

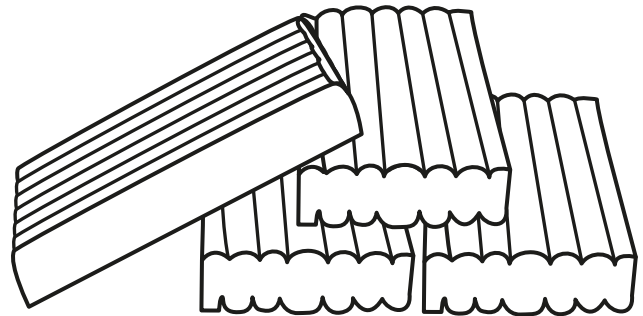

Modeling clay

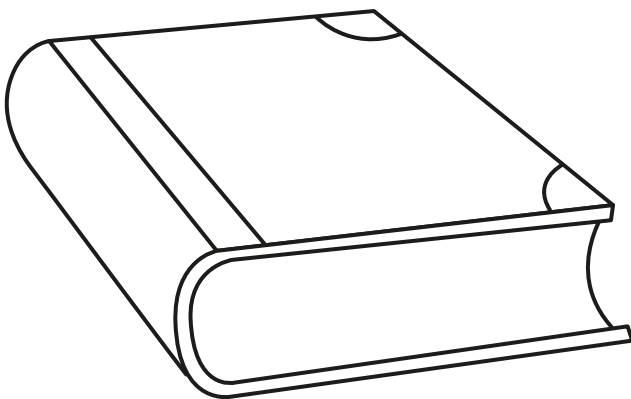

Book

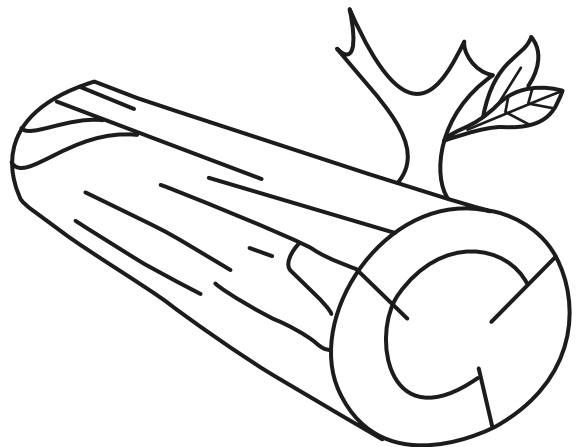

Wood





Liquids will flow, and take the shape of whatever container they are in. They can also be poured. Some liquids flow faster than others.

TEST What You Need:

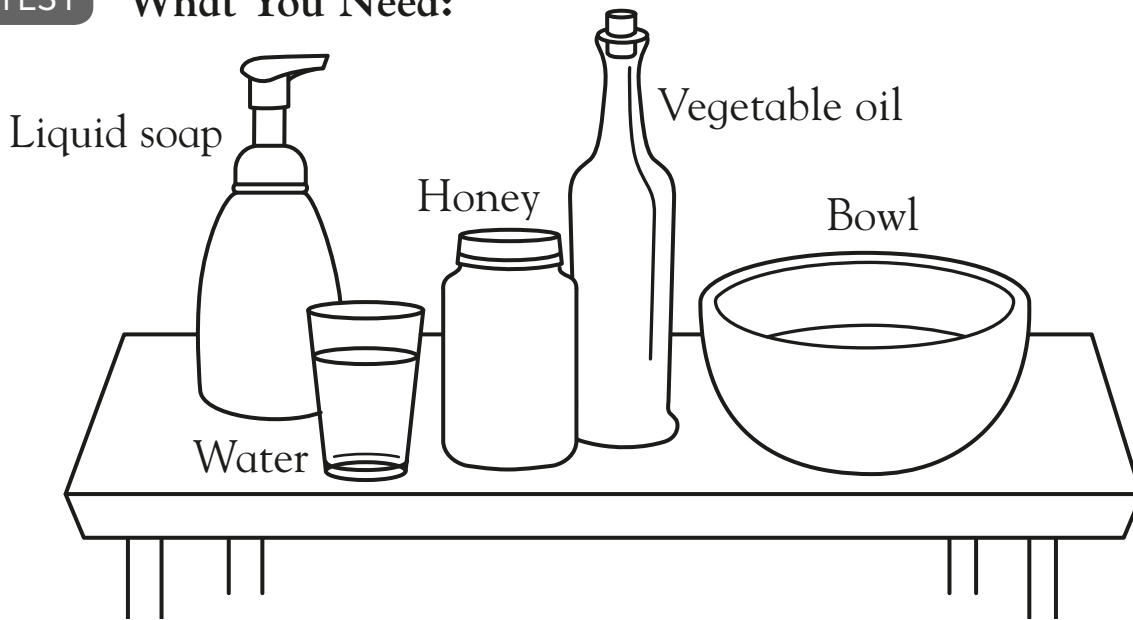

What To Do:

1. Pour a small amount of the liquid soap into the bowl. How quickly did the soap pour? Now pour a small amount of water. How quickly did that pour? Repeat with the honey and vegetable oil.
2. Make note of which liquid poured fastest and which poured slowest.

RESULT

Liquid that pours fastest

Liquid that pours slowest





Some solids mix into liquids so that the solid seems to disappear. The solid dissolves into the liquid. This happens when you mix sugar into water. You can no longer see the sugar, but you know it is there because the water tastes sweet. Salt is another solid that dissolves in liquids. But some solids, such as pebbles or rice, will not dissolve.

Look at the pictures below. Each one shows a solid next to a liquid. Circle the two solid and liquid pairs where the solid will dissolve into the liquid.

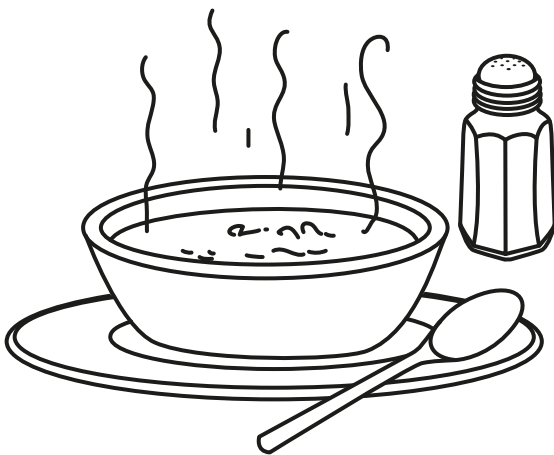

Soup and salt



Water and rice

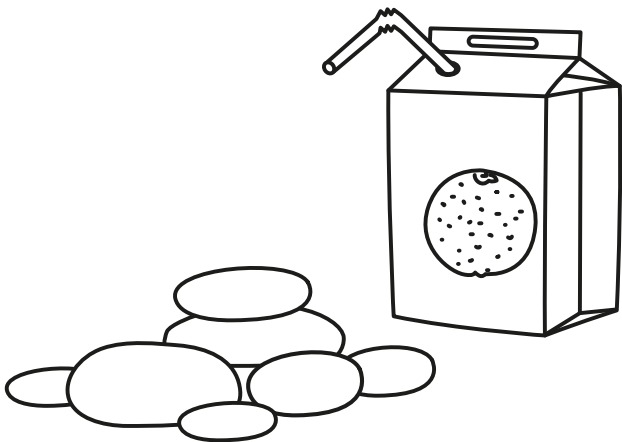

Juice and pebbles

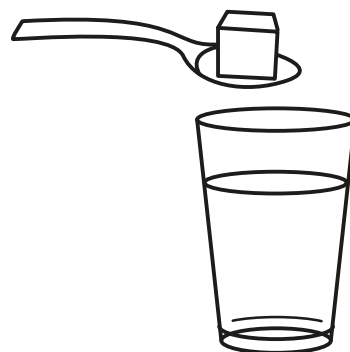

Water and sugar



Heat and Dissolving

FACTS

How hot or cold a liquid is can make a difference to how quickly a solid will dissolve in it.

TEST What You Need:

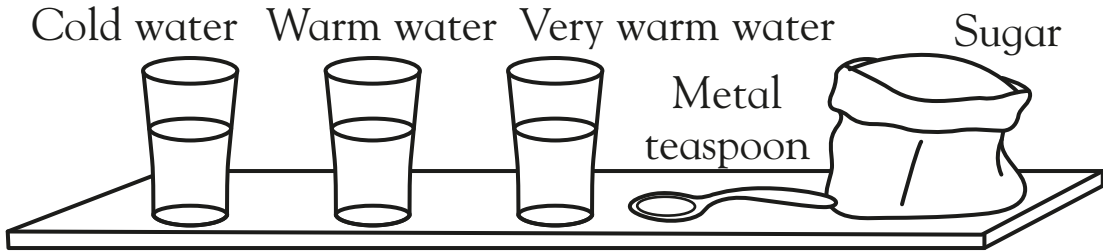

What To Do:

1. Take three glasses. Fill one halfway with cold water, another with warm water, and the third with very warm water.
2. Stir a teaspoon of the sugar into the cold water, counting how many times you have to stir until the sugar has completely dissolved. Make a note of the number of stirs on the chart.
3. Repeat Step 2, stirring a teaspoon of sugar into the warm water. Again count and note the number of stirs it takes for the sugar to completely dissolve. Repeat again, stirring sugar into the very warm water.

RESULT Look at your results on the chart and answer the question.

Water at Different Temperatures	Number of Stirs
Cold water	
Warm water	
Very warm water	

Does the sugar dissolve faster as the water gets hotter?





Air is a mixture of invisible gases. You cannot see it, but you can feel it blowing on a windy day. Just like solids and liquids, gases have weight, and some gases are heavier than others. A balloon filled with a light gas will float up higher than a balloon filled with a heavier gas.

Look at the picture below. The balloon with the swirly dots is filled with a very light gas. The stripy balloon is filled with a heavier gas. The balloon with the clouds on it is filled with the heaviest gas.



1. Point to the balloon with the heaviest gas.

2. Point to the balloon with the lightest gas.

3. Is the stripy balloon heavier or lighter than the balloon with the swirly dots?

.....





Water

FACTS

Water is usually a liquid, but it can also exist as a solid or gas. When you put water in the freezer, it turns into a solid by becoming ice. When your mom or dad boils water on the stove, it turns into a gas by becoming steam.

Look at the images below. Circle the images where water is a liquid. Make a square around the images where water is a gas. Make a triangle around the images where water is a solid.

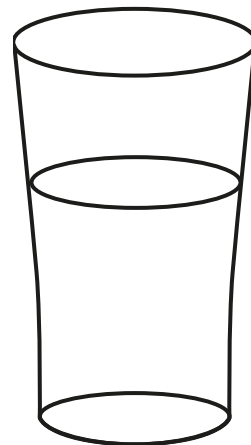
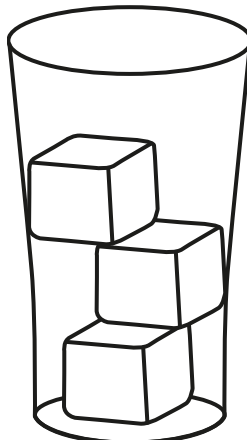
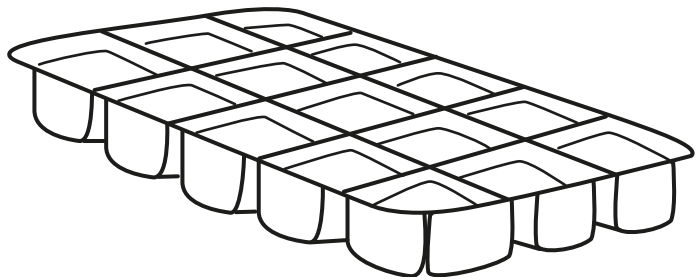
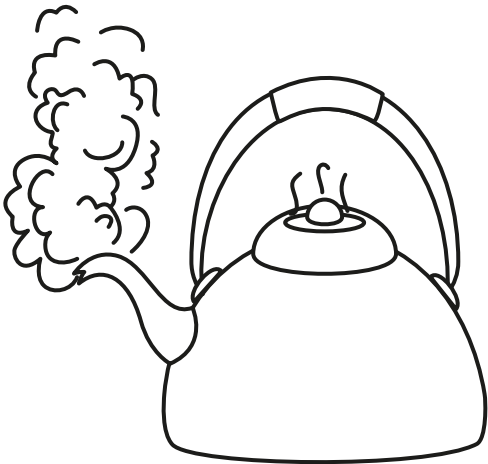



Scientists can tell us what kind of weather we are likely to have in the days and even weeks to come. This helps us prepare for our day, and choose what to wear (and bring) when we go out.

Look at the four scenes below. Then look at the clothes. Draw a line between each scene and the best clothes for the weather shown.

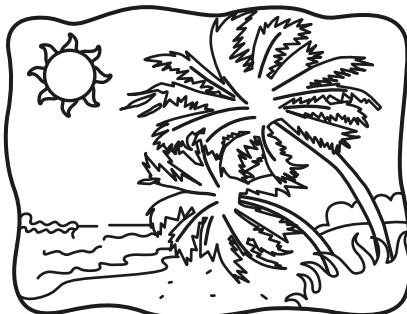
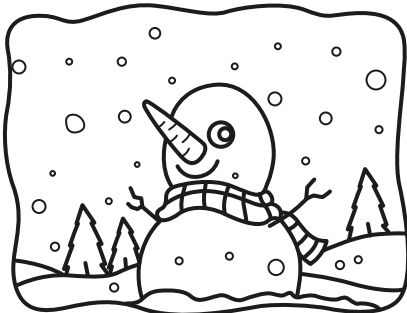
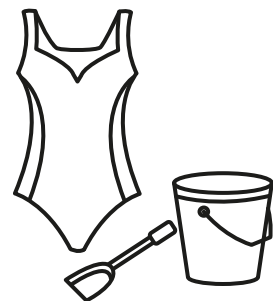
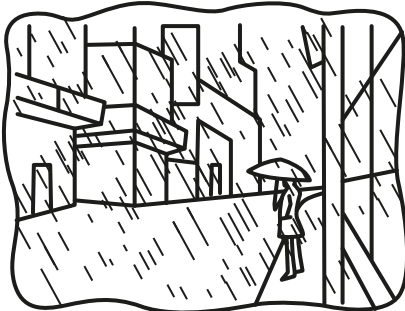



Certificate



**1st
Grade**

Congratulations to

.....

for successfully
finishing this book.

GOOD JOB!

You're a star.



Date

.....

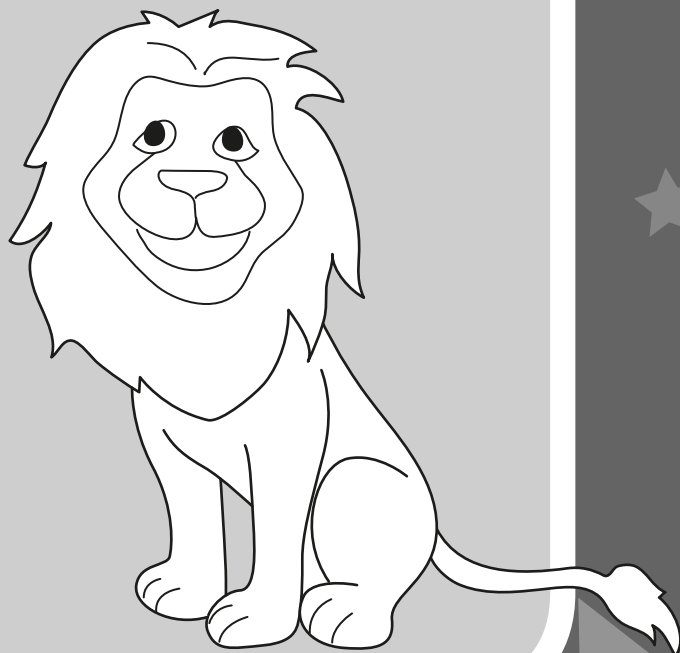

Answer Section with Parents' Notes

The aim of this book is to introduce basic literacy, numeracy, and science concepts to your child. These activities are intended to be completed by a child with adult support.

How to Help Your Child

As you work through the pages with your child, make sure he or she understands what each activity requires. Read the facts and instructions aloud. Provide support while your child completes the activity. Encourage questions and reinforce observations to build confidence and increase active participation at school.

If an activity seems too challenging, encourage your child to try another page. Be sure to praise progress made as a page is completed, a correct answer is selected, or a thoughtful response is given. If they are getting answers wrong, then encourage them to try again another time. Above all, remember to have fun!

Spelling and Language Arts Pages

These pages of the workbook are designed to help your child build first-grade literacy skills. As you work through the pages, help your child connect the content to specific personal experiences and keep making connections to the world around you. For example, practice writing skills by labeling pictures your child has drawn, or point out how words are spelled on signs around town. When appropriate, use props such as pictures or flash cards to help your child visualize letters and words. By working with your child, you will understand how he or she thinks and learns.

Math Pages

Your child's reading ability may not be up to the level of some of the more advanced math words, so be prepared to assist. Working with your child also has great benefits in helping you understand how he or she is thinking and where stumbling blocks may be. When appropriate, use props to help your child visualize the solutions—for example, have a collection of coins to use for the money problems.

Science Pages

First graders will not be able to read most of the instructions on these pages—that is understood by the author. There is an expectation that parents will work closely with children as they progress through the book. Both parents and children can gain a great deal from working together. Perhaps the most important thing you can do is encourage children to be curious about the world around them. Ask them questions such as “Why?,” “What if?,” and “What do you think?” Do not be negative about their answers, however silly they may be. There is almost certainly a logic to their response, even if it is not correct. Explore and discuss their ideas with them.

★ Letters and Sounds

FACTS

Aa Bb Cc Dd Ee Ff Gg Hh Ii Jj Kk Ll Mm
Nn Oo Pp Qq Rr Ss Tt Uu Vv Ww Xx Yy Zz

We spell words using the 26 letters of the alphabet. The alphabet has uppercase and lowercase letters, which are written together above. Letters are either consonants or vowels.

Circle the letter that makes the beginning sound of the name of each picture.



u s



b d



m b



b s



c s



c f



w f



a q



l h

4 a d w c s k f b m h q a n w s c j i g i k e y z

Ask your child to say the beginning sounds of his or her name and to identify the letter. Next, help your child to make the sound of each beginning letter on this page.

Beginning Consonants ★

FACTS

There are 20 consonants in the alphabet. Five letters in the alphabet (a, e, i, o, and u) are always vowels. The letter y is sometimes a consonant and sometimes a vowel. Consonants often come at the beginning of words.

Write the letter that begins the name of each picture.



f an



b at



w ig



c at

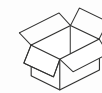

b ox



k ey

Circle the letter that makes the beginning sound of each picture's name.



m s



p r



c a

Now write the words in alphabetical order.

car

pencil

shoe

5 a d w c s k f b m h q a n w s c j i g i k e y z

Continue to reinforce beginning consonant sounds. You might want to explain that different letters can make the same sound in some words, such as c and k in "cut" and "kind."

★ Ending Consonants

FACTS

Consonants can come at the end of words, too.

Read each word aloud and listen to its ending sound. Circle the consonant at the end of each word.



bug



sit



pan



cap



cow



gum

Draw a picture of something whose name ends in the consonant t. Then write its name.

Answers may vary

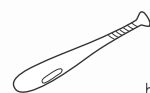

bat

6 a d w c s k f b m h q a n w s c j i g i k e y z

Say a word and let your child identify the ending sound. Next, say groups of three words with the same ending consonant and let your child identify the sound and the letter that makes the sound.

Consonant Blends ★

FACTS

Consonant blends are two or more consonants that come together to make one sound. Some consonant blends come at the beginning and others at the end of words. For example, say the word "glove." Listen to the "gl" sound at the beginning.

Read the name of the first picture aloud. Listen to the beginning blend. Then circle the name of the picture with the same beginning sound.



fruit



plane



frog



kite



clock



clown



globe



skunk

Read the name of the first picture aloud. Listen to the ending blend. Circle the name of the picture with the same ending sound.



ring



king



nest



salt



hand



sink



shelf



band









7 a d w c s k f b m h q a n w s c j i g i k e y z

Find things with names that begin with consonant blends, such as a glove or a crayon. Let your child say the name aloud. Then help him or her identify and write the letters in the blend. Repeat with things that have names with ending blends, such as a belt or a lamp.

★ The Vowels

FACTS The vowels in the alphabet are a, e, i, o, u, and sometimes y. We see vowels in the middle of many words.

Write the beginning letter of each picture's name in the box below it. The three letters form a word. Circle the letter in the word that is a vowel. Read the word aloud.

 m	 a	 p
 p	 e	 t
 h	 u	 g

In the words below, move your finger over each letter and make its sound. Read the word aloud.

 bag	 pen	 dog	 bib
--	--	--	--

8 a d w c s k f b o m h q a n w s c j i g e y z

Say the word "dog." Then say the separate letter sounds of the word "d-o-g." After that, ask your child to say "dog." Then ask him or her to identify the letter that makes the middle sound of the word.

Missing Vowels ★

FACTS The vowels a, e, i, o, and u each have a long sound and a short sound. When used as a vowel, y makes a long "i" sound or a long "e" sound.

Some vowels in the picture are missing. Where in the world can they be? Look at each word in the picture. Write in its vowel, please!

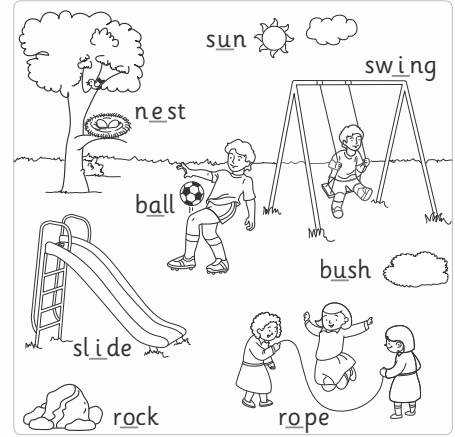











9 a d w c s k f b o m h q a n w s c j i g e y z

Have your child listen carefully as you say these three words: "sun," "fun," and "cat." Let him or her identify which word has a different middle sound. Ask your child how that sound is different and which letter is associated with that sound.









★ Beginning Consonant Blends

FACTS A blend is two or more consonant sounds used together. Some blends come at the beginning of words. For example, say the word "frog" and listen to the sound of the "fr" blend.

Say the name of the first picture. Listen to the beginning blend. Circle the pictures that have names that begin with the same blend sound.

 glove	 goat	 globe	 glue
 crib	 crayon	 cat	 crown
 skate	 skirt	 smoke	 skull

Say the name of each picture below. Circle the correct beginning blend.

 gl	 pl	 fl	 gr	 pr	 br	 sq	 sk	 st
---	---	---	---	---	---	---	---	---

10 a d w c s k f b o m h q a n w s c j i g e y z

Cut out pictures of items whose names begin with blends, such as a flower, drum, and truck. On one set of index cards, write the name of each item. On a second set of cards, write the beginning consonant blend of each name. Let your child sort the cards and pictures into the correct groups.

Ending Consonant Blends ★

FACTS Some consonant blends come at the end of words, such as in the word "jump." Listen to the ending "mp" sound.

Write the correct consonant blend to finish each word.

 bel_t	 rin_g	 mil_k	 lam_p
--	--	--	--

Use a word from above to complete each sentence.



I have a lamp in my bedroom.

He wore a brown belt with his pants.

I like to drink milk.

I have a ring on my finger.

Draw a line from the ending consonant blend to the picture it matches.

ng	lf	nk
 shelf	 sink	 string

11 a d w c s k f b o m h q a n w s c j i g e y z

Write letter problems such as these for your child to combine to form a word:
 ri + ng = _____
 sa + lt = _____
 Use any of the ending blends from this page to create these letter problems.













★ Digraphs at the Beginning

FACTS

Consonant digraphs are two letters that join to make one sound. For example, words like "chick," "thirty," "ship," and "wheel" have the consonant digraphs ch, th, sh, and wh at the beginning.

Look at each picture. Choose the correct beginning sound from the box to write under each picture.

ch th sh wh

 <u>ch</u>	 <u>wh</u>	 <u>th</u>	 <u>sh</u>
 <u>sh</u>	 <u>ch</u>	 <u>wh</u>	 <u>sh</u>
 <u>th</u>	 <u>wh</u>	 <u>sh</u>	 <u>ch</u>

12 a d w c s k f b m h q n w s C i g i k e y z

Walk around a room with your child, pointing at items whose names begin with a digraph. These items might include a shadow, chain, chair, whistle, chin, chips, and shutters. Let your child say the name of each item and identify the beginning digraph sound and letters.













Digraphs at the End ★

FACTS

Consonant digraphs can sometimes come at the end of words. For example, words like "sock," "each," "wish," and "math" have the consonant digraphs ck, ch, sh, and th at the end.

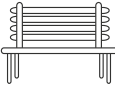
Look at the pictures below. Choose the correct ending sound from the box to write under each picture.

sh ch ck th

 <u>sh</u>	 <u>th</u>	 <u>ck</u>	 <u>ch</u>
 <u>ck</u>	 <u>ch</u>	 <u>ck</u>	 <u>th</u>
 <u>ch</u>	 <u>ck</u>	 <u>sh</u>	 <u>ck</u>

a d w c s k f b m h q n w s C i g i k e y z 13

With your child, walk around a room pointing at items whose names end with a digraph found on this page, such as dish, couch, washcloth, and toothbrush. Let your child say the name of the item and identify the ending digraph sound and letters.

★ Sight Words

FACTS

Some words are so common that you will soon begin to recognize them instantly. These are called sight words. Many of them are not sounded out as they are spelled.

Look at the scrambled letters. Unscramble them to form a word from the box. Write each word and read it aloud.

most	of	are	the
put	one	been	two
eth	the	neo	one
owt	two	rea	are
tup	put	fo	of
nebe	been	msto	most

From the word box below, write the correct word for each word meaning.

different great four

the word for 4 four

the opposite of same different

a word for wonderful great



14 a d w c s k f b m h q n w s C i g i k e y z

Reinforce the sight words on this page by making word cards and then help your child to form the letters out of clay. Then your child can touch each letter of the word to "feel" its spelling.

More Sight Words ★

FACTS



Sight words are also known as high-frequency words. Some more high-frequency words are "after," "again," "from," "once," and "thank."

Read each word aloud. Write each word on the basket that shows its beginning letter.

some what do often they

would old where does their

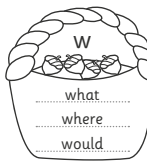
should school thought different only

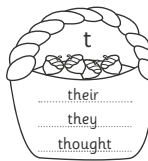
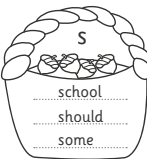
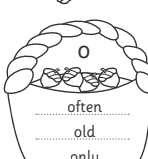
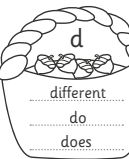
 w what where would		 t their they thought
 s school should some	 o often old only	 d different do does

a d w c s k f b m h q n w s C i g i k e y z 15

Encourage your child to use the sight words on this page to create his or her own oral sentences. Check to be sure that your child is using each word correctly.

FACTS

Pronouns are words that can take the place of nouns in a sentence.

Circle the pronoun in each sentence. Then write the pronoun.

My dog is small and fluffy.

My

Where are **you** going?

you

**They** went to the movies.

They

Jane gave **her** a book.

her

**He** needs new shoes.

He

**I** like to bake cookies.

I

**We** sang together.

We

Have your child say a sentence that uses a pronoun instead of a proper name.

FACTS

The most common pronouns are "he," "she," and "it."

Find the pronoun from the word bank to replace the bold word in each sentence. Then write the word.

He It She

Jenny got into the car.

She got into the car.



Mr. Brown told us a story.

He told us a story.

The star shines brightly.

It shines brightly.



The frog hopped into the pond.

It hopped into the pond.

My aunt made pizza.

She made pizza.



When you read with your child, be on the lookout for pronouns. Ask your child to whom or to what the pronoun refers.

FACTS

A verb is a word that names an action or a state of being.

Read each sentence aloud. Draw a line under the verb.

The skunk plays the horn.The fox dances.The moose sings.The bear listens.The raccoon claps.The owl flies away.

Practice using verbs by giving your child verbs to demonstrate.

FACTS

Verbs in the present tense name an action that is happening now.

Read the sentences aloud. Pick the verb from the word bank that completes each sentence.

eat rests sinks wait whistle

The cat rests on the bed.I eat my lunch.I can whistle a tune.We wait for the bus.The rock sinks to the bottom of the pond.

After completing the activity on page 20, invite your child to come back to the verbs on this page. Help your child put them in the past tense.

★ Past Tense

FACTS

Verbs in the past tense name an action that has already happened. Some verbs can be put in the past tense by adding -ed to the end.

Read the sentences aloud. Pick the verb from the word bank that completes each sentence.

baked helped planted played skated

Dear Grandma and Grandpa,
 I had a busy day today! My mom and I baked a cake. Then my dad and I planted seeds in the garden. After that, my friend and I skated at an ice-skating rink. I fell on the ice, but my friend helped me up. Finally, we played video games until it was time to go home. I am tired now!
 Love,
 Chris

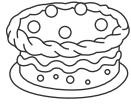

Ask your child to describe the previous day's activities using verbs in the past tense.

Future Tense ★

FACTS

A verb is a word that names an action. Verbs in the future tense name an action that has not yet happened but will happen later.

Verbs in the future tense are usually paired with "will." Complete each sentence by writing the verb in the future tense.

Dad will wash the car. (wash) 

You will cook dinner tonight. (cook) 

We will ride the bus to school tomorrow. (ride) 

I will meet you at the park at 3:00 p.m. (meet) 

James will visit his cousins next summer. (visit) 

The chef will add salt to the soup if she needs to. (add) 

Ask your child to say what may happen tomorrow, using verbs in the future tense.

★ Singular to Plural Nouns

FACTS

Singular means one. Plural means more than one.

To make some words plural, add an s at the end of the word. Add es to make a plural of a word that ends in ch, sh, s, or x. Make these words plural.



heads



pieces



hearts



watches



classes



schools



boxes



wishes

Challenge your child to find examples of plural nouns printed around your house (such as on food packaging, game boxes, or the titles of books). Ask your child to name the singular noun.

Nouns and Verbs ★

FACTS

Nouns and verbs combine to make sentences.

A verb that tells what a single person or thing does usually ends in s. Circle the correct verb to complete each sentence.

The rabbit dig (digs) a deep hole.

The acrobat flip (flips) through the air.

The wizard turn (turns) the elephant into a mouse.

Birds (lay) lays their eggs in a nest.

Authors (write) writes books.

The Earth spin (spins) on its axis.

A bagel taste (tastes) yummy with jelly.

The soccer players practice (practices) every day.

When a verb is properly matched to a noun (i.e., "Joe plays" versus "Joe play"), the noun and verb are in agreement.

★ Is and Are

FACTS
The word "is" tells what one person or thing is doing now.
The word "are" tells what more than one person or thing is doing now.

Complete each sentence with "is" or "are."

- The cats are having a party.
- Joe Cat is hanging balloons.
- Moe Cat is putting out food.
- Zoe Cat and Roe Cat are playing music.
- Loe Cat is dancing.
- They are having fun!



24 O d W C S k f b o m h q a n w s C j g i k e y Z

Invite your child to come up with original sentences using "is" and "are."

Word Endings ★

FACTS
Verbs can have endings that tell when the action took place.
The verb on its own is called a root word.

Read the pairs of sentences. Use -ing to complete the root word that describes something happening now. Use -ed to complete the root word that describes something that has already happened.

Dad is cooking dinner.



Mom cooked dinner last night.

I sewed a button on my shirt last week.



It fell off, so I am sewing it again.

We watched a movie in school this morning.



Now we are watching a movie at home.

O d W C S k f b o m h q a n w s C j g i k e y Z 25

Stay on the lookout in your everyday life for printed words ending in -ing or -ed. Ask your child to name the root words of those words.

★ Adjectives

FACTS
Adjectives are words that describe people, places, and things.

Pair each noun with an adjective from the word bank.
Then write a complete sentence using both words.
Finally, draw your characters in the woods.

Nouns

bear snake bird fox

Adjectives

colorful huge silly sleepy

Answers may vary

Answers may vary

Answers may vary

Answers may vary

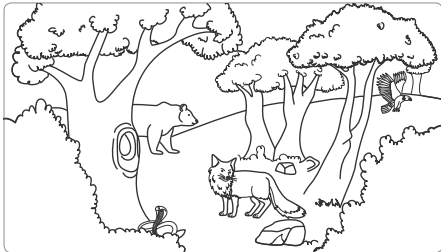

26 O d W C S k f b o m h q a n w s C j g i k e y Z

Ask your child to use adjectives to describe the things around you.

Prepositions ★

FACTS
A preposition relates a noun or a pronoun to another word in the sentence.

Complete each sentence with a preposition from the word bank.

behind beside in on over under

Answers may vary

The bird is in the tree.



The bird is under the tree.

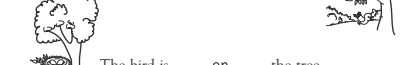

The bird is on the tree.

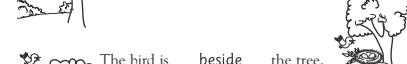

The bird is beside the tree.



The bird is over the tree.



The bird is behind the tree.

O d W C S k f b o m h q a n w s C j g i k e y Z 27

There are many songs and rhymes to help children understand prepositions. Look online for prepositional rhymes and songs to share with your child.

★ Tens and Ones (Place Value)

GOAL

Learn about groups of tens and ones.



How many ladybugs are there? **Remember:** First count how many groups of ten there are, then count the ones that are left.

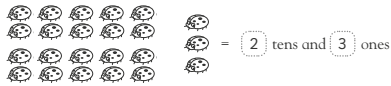
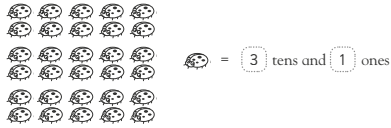

How many ants are there? Circle a group of ten, then count the ants that are left over. Write your answer in terms of tens and ones.

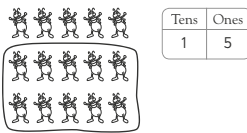

Be sure children count groups of ten carefully. If they miscount a group of ten, they will reach an incorrect answer. You may want to have children practice counting tens and ones using groups of buttons.

Finding Tens and Ones ★

GOAL

Learn to find groups of tens and ones.

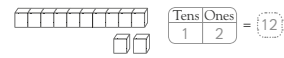

For each problem, count the number of groups of ten blocks, and write that number under "tens." Then count how many blocks are left, and write that number under "ones." How many total blocks are there in each problem?

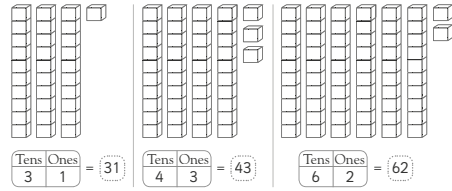

Fill in the boxes and write the correct number.

Tens Ones Number
 2 tens and 8 ones = 2 + 8 = 28
 9 tens and 4 ones = 9 + 4 = 94
 3 tens and 6 ones = 3 + 6 = 36

Write these numbers as tens and ones.

20 = 2 tens and 0 ones 72 = 7 tens and 2 ones
 35 = 3 tens and 5 ones 17 = 1 ten and 7 ones

Be sure children understand that in two-digit numbers, the second digit stands for the number of units in the ones column, and the first digit stands for the number of units in the tens column.

★ Show One More

GOAL

Learn about adding one more to a number.



In each row, first count the smiley faces, then draw one more. How many are there in each row now? Write the total number.



Complete the chart.

Starting Number	Add One More	New Number
9	1	10
6	1	7
4	1	5
5	1	6

Add the two groups of hearts. Write the total in the box.



Use groups of clothespins to show a number. Ask children to count them aloud. Then add one more clothespin to the group of clothespins, and have children count aloud again. Clarify that the new total number of clothespins is larger because you added one more.

Show One Less ★

GOAL

Find out how to subtract one from a number.



Count the number of objects in each row. Then cross out one. How many are there now?

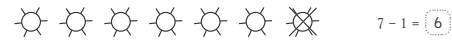

Look at the pictures in each column. Circle the picture that shows one less.

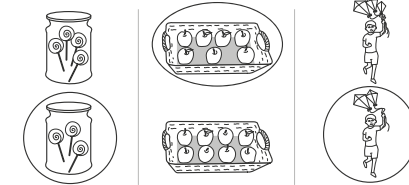

Subtract one from the group of stars below. Write the subtraction sentence.



Show children a group of small toys. Let children count them. Then take one toy away, and ask them to count the toys again. Help them figure out and recite the subtraction sentence, such as, "five minus one equals four."

32

★ Find Ten More

GOAL Learn to add ten to a number. 3 add ten = 13

Look at the puzzle pieces. Add ten to each number on the left. Then draw a line from each puzzle piece on the left to its matching number + ten on the right.
Remember: The number on the right must be ten more than the number on the left.

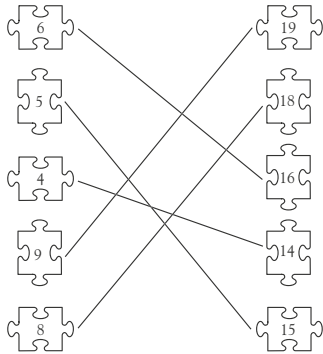

How many groups of ten are there in each number below? Write the answer in the box.

12 (1) 35 (3) 26 (2)

32 12345678912345678912

Help children understand that ten more have been added to the number in the first column to come up with its match in the second column. You can demonstrate the concept by using blocks.

33

Find Ten Less

GOAL Learn to subtract ten from a number. 15 subtract ten = 5

Subtract ten from each number in the left column. Then write the subtraction sentence and the answer in the right column.

32 subtract ten	$32 - 10 = 22$
28 subtract ten	$28 - 10 = 18$
25 subtract ten	$25 - 10 = 15$
56 subtract ten	$56 - 10 = 46$
21 subtract ten	$21 - 10 = 11$
36 subtract ten	$36 - 10 = 26$
44 subtract ten	$44 - 10 = 34$
18 subtract ten	$18 - 10 = 8$
68 subtract ten	$68 - 10 = 58$
95 subtract ten	$95 - 10 = 85$

Finish the pattern. Write the number that is ten less each time.

50 40 30 20 10 0

12345678912345678912 33

Use a set of dominoes to help children understand subtraction: Have them count the dots on a domino, then cover up one or more dots and ask them to count again. Help children write the corresponding subtraction sentence each time.

34

★ Adding Up to 10

GOAL Learn how to add up to 10. $1 + 9 = 10$

Read the addition sentences in each row. Then color the flowers using two colors to show the addition sentence.

$6 + 4 = 10$	
$8 + 2 = 10$	
$7 + 3 = 10$	
$2 + 8 = 10$	
$3 + 7 = 10$	
$4 + 6 = 10$	
$9 + 1 = 10$	
$5 + 5 = 10$	

Complete these addition sentences by writing the missing number.
 $4 + 6 = 10$ $8 + 2 = 10$ $3 + 7 = 10$

34 12345678912345678912

Have children first say the number sentence, then count out the corresponding groups of flowers to color. Create more number and coloring sentences for children to complete using other objects, like stars, suns, or balls.

35

Practice Adding Up

GOAL Practice your addition skills. $10 + 10 = 20$



Help the clown reach the circus tent. First add each number sentence. Then follow the path of the number sentences with answers that are twenty or less.

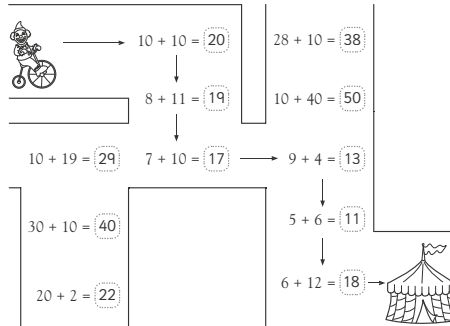

Draw groups of clown hats to show this number sentence: $3 + 3 = 6$.

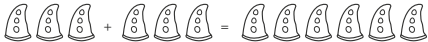

12345678912345678912 35

You may want to ask children to rewrite each number sentence on another piece of paper, to practice and reinforce adding up to twenty.

★ Subtraction from 0 to 10

GOAL

Learn how to subtract with numbers between 0 and 10.



Look at the groups of fruit in each row. Then write the answer for each subtraction sentence.



Joan counted six oranges in her bowl. She ate two. How many oranges were left?

Write the number sentence.

6 - 2 = 4



Place ten or fewer marbles in a jar. Have children count them. Then ask them to close their eyes as you remove a number of the marbles. Let them recount the marbles and write the corresponding subtraction sentence.

Practice Subtraction ★

GOAL

Practice your subtraction skills.



Subtract and write the answers in each row.

$\begin{array}{r} 15 \\ - 4 \\ \hline 11 \end{array}$	$\begin{array}{r} 29 \\ - 6 \\ \hline 23 \end{array}$	$\begin{array}{r} 18 \\ - 5 \\ \hline 13 \end{array}$	$\begin{array}{r} 16 \\ - 4 \\ \hline 12 \end{array}$	$\begin{array}{r} 12 \\ - 2 \\ \hline 10 \end{array}$	$\begin{array}{r} 19 \\ - 3 \\ \hline 16 \end{array}$
---	---	---	---	---	---

$\begin{array}{r} 10 \\ - 7 \\ \hline 3 \end{array}$	$\begin{array}{r} 9 \\ - 5 \\ \hline 4 \end{array}$	$\begin{array}{r} 39 \\ - 4 \\ \hline 35 \end{array}$	$\begin{array}{r} 20 \\ - 10 \\ \hline 10 \end{array}$	$\begin{array}{r} 16 \\ - 8 \\ \hline 8 \end{array}$	$\begin{array}{r} 56 \\ - 6 \\ \hline 50 \end{array}$
--	---	---	--	--	---

$\begin{array}{r} 14 \\ - 7 \\ \hline 7 \end{array}$	$\begin{array}{r} 9 \\ - 6 \\ \hline 3 \end{array}$	$\begin{array}{r} 60 \\ - 30 \\ \hline 30 \end{array}$	$\begin{array}{r} 89 \\ - 9 \\ \hline 80 \end{array}$	$\begin{array}{r} 18 \\ - 15 \\ \hline 3 \end{array}$	$\begin{array}{r} 58 \\ - 8 \\ \hline 50 \end{array}$
--	---	--	---	---	---

Read each story. Then write the answer for each subtraction problem.

Juan had thirteen crayons. He broke two crayons. How many of his crayons were not broken?  13 - 2 = 11



We saw twenty-five bunnies. Four bunnies ran away. How many bunnies were left? 25 - 4 = 21

Jen made nineteen cupcakes. She gave away six cupcakes. How many cupcakes were left? 

19 - 6 = 13

Write subtraction problems up to twenty on index cards. Write an answer for each problem on another index card. Place all cards on a table faceup. Let children match a problem card with the correct answer card.

★ Recognizing Money

GOAL

Learn the names of coins.



Follow the directions in each section.

Answers may vary

Circle four pennies.



Circle three nickels.



Circle five dimes.

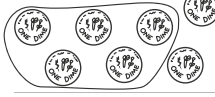

Circle two quarters.



Circle two pennies and one nickel.



Circle three dimes and one quarter.



Read the amount of cents. Circle the coins that make each amount.

10¢ =



15¢ =



Engage children in coin riddles: Give clues to a coin you are thinking of, such as, “two of this coin makes two cents,” (penny) or “two of this coin makes ten cents” (nickel). Let them work out what the mystery coin is.

Adding Money ★

GOAL

Practice adding money.

$\begin{array}{r} 25¢ \\ + 12¢ \\ \hline 37¢ \end{array}$

Add the amounts of money in each row.

$\begin{array}{r} 30¢ \\ + 12¢ \\ \hline 42¢ \end{array}$	$\begin{array}{r} 17¢ \\ + 22¢ \\ \hline 39¢ \end{array}$	$\begin{array}{r} 33¢ \\ + 25¢ \\ \hline 58¢ \end{array}$	$\begin{array}{r} 37¢ \\ + 30¢ \\ \hline 67¢ \end{array}$	$\begin{array}{r} 14¢ \\ + 10¢ \\ \hline 24¢ \end{array}$
---	---	---	---	---

$\begin{array}{r} 50¢ \\ + 30¢ \\ \hline 80¢ \end{array}$	$\begin{array}{r} 27¢ \\ + 61¢ \\ \hline 88¢ \end{array}$	$\begin{array}{r} 17¢ \\ + 21¢ \\ \hline 38¢ \end{array}$	$\begin{array}{r} 35¢ \\ + 13¢ \\ \hline 48¢ \end{array}$	$\begin{array}{r} 32¢ \\ + 17¢ \\ \hline 49¢ \end{array}$
---	---	---	---	---

$\begin{array}{r} 21¢ \\ + 50¢ \\ \hline 71¢ \end{array}$	$\begin{array}{r} 16¢ \\ + 11¢ \\ \hline 27¢ \end{array}$	$\begin{array}{r} 30¢ \\ + 24¢ \\ \hline 54¢ \end{array}$	$\begin{array}{r} 23¢ \\ + 22¢ \\ \hline 45¢ \end{array}$	$\begin{array}{r} 18¢ \\ + 20¢ \\ \hline 38¢ \end{array}$
---	---	---	---	---

$\begin{array}{r} 33¢ \\ + 12¢ \\ \hline 45¢ \end{array}$	$\begin{array}{r} 25¢ \\ + 22¢ \\ \hline 47¢ \end{array}$	$\begin{array}{r} 40¢ \\ + 23¢ \\ \hline 63¢ \end{array}$	$\begin{array}{r} 23¢ \\ + 60¢ \\ \hline 83¢ \end{array}$	$\begin{array}{r} 16¢ \\ + 12¢ \\ \hline 28¢ \end{array}$
---	---	---	---	---

Look at each group of coins. Circle the one with the most money.









Write simple addition money problems for children to mirror using coins. For example, if you write “4¢ + 10¢,” they could mirror the sentence by showing four pennies plus one dime, or four pennies plus two nickels. Let them count the coins to find the sum.

★ Double Trouble

GOAL Learn to double amounts. $5¢ + 5¢ = 10¢$ $4¢ + 4¢ = 8¢$

Look at the coins on the left, then draw the coins you need to double each amount. Add to find the total amount in each row.

 +  = 4¢
 +  = 20¢
 +  = 60¢

Write the answer to each addition problem. Circle the equations that show doubled amounts.

$8¢ + 1¢ = 9¢$ $5¢ + 2¢ = 7¢$ $5¢ + 5¢ = 10¢$ $9¢ + 8¢ = 17¢$
 $9¢ + 2¢ = 11¢$ $5¢ + 4¢ = 9¢$ $6¢ + 3¢ = 9¢$ $7¢ + 7¢ = 14¢$

Pam had four apples. Dan bought four peaches. How many pieces of fruit did they have in all? Write the number sentence. $4 + 4 = 8$
Is the answer a double? Yes







Let children practice adding doubles by creating doubles number sentences using buttons or paper clips. Help them add the doubles to reach the correct sum.

Shopping ★

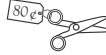





GOAL Find the coins you need to use when buying an item.



Look at the prices of the items. Circle the coins required to buy the item in each row.



 
 
 

Draw a line to match the treat with the coins you need to buy it.









 
 
 

Place pennies, nickels, dimes, and quarters on a table. Hold up an object, such as a box of crayons or a small toy, and tell the children what it costs to buy. Let them find the correct coins from the money on the table to “buy” the object.

★ Figuring Out Change

GOAL Learn about getting back change. You have  You buy  Will you get change? Yes No

Count how much money you have, and write the amount in the box. Look at the price of what you buy. Figure out if you will get change, and circle “yes” or “no.”

You have  30¢ You buy  Will you get change? Yes No
 You have  35¢ You buy  Yes No
 You have  15¢ You buy  Yes No
 You have  75¢ You buy  Yes No



Jon has 35¢. He buys a toy truck for 24¢. How much change will John get back? $35¢ - 24¢ = 11¢$

Remind children that they will receive change if the amount of money they have is greater than the cost of the item they are buying. Also have them practice writing amounts of money using the cents (¢) sign.

Giving Change ★

GOAL Learn how to calculate change using subtraction. I have 20¢. I buy one apple.  I will get 5¢ change.

Read each problem, and write the answer in the last column.

I have 50¢ I buy  I will get this much change. 10¢
 I have 70¢ I buy  I will get this much change. 40¢

Look at the prices of snacks given below. Then write the subtraction sentence and answer for each of the problems.

yogurt 30¢ bagel 40¢ bag of pretzels 35¢
 Sara has 50¢. She buys a container of yogurt from Mr. Jones. How much change should Mr. Jones give Sara? $50¢ - 30¢ = 20¢$
 Jill has 50¢. She buys a bagel from Mr. Jones. How much change should Mr. Jones give Jill? $50¢ - 40¢ = 10¢$
 Sei has 75¢. She buys a bag of pretzels from Mr. Jones. How much change should Mr. Jones give Sei? $75¢ - 35¢ = 40¢$

Ask children to pretend they have 99¢. Cut pictures of toys from magazines, and give each toy a price of less than 99¢. Children can select a toy to “buy,” then subtract its price from 99¢ to find the change they would receive.

★ Telling the Time: O'Clock

GOAL

Learn to tell what time it is. This clock shows 2 o'clock.



The minute hand moves as the minutes go by.
The hour hand points to the hour of day.

Fill in the number to tell what time each clock shows.



1 o'clock



4 o'clock



8 o'clock



11 o'clock



9 o'clock



3 o'clock



7 o'clock



12 o'clock



5 o'clock

Fill in the correct numbers in the sentence below.

At 3 o'clock, the minute hand points to 12 and the hour hand points to 3.



44 12345678912345678912

Use a toy clock to help children tell the time. Say a time, and let them move the hands to the correct hour. Then have children say the hour and name an activity that might take place at that time.

Half Past ★

GOAL

Learn to tell the time to the half hour. "Half past" means that it is 30 minutes past the hour. When you say "half past one," it is the same as saying "one thirty."



1:30
One thirty

Write the correct time for each clock in numbers and in words.



3 : 30
Three, thirty



6 : 30
Six, thirty



7 : 30
Seven, thirty



5 : 30
Five, thirty



2 : 30
Two, thirty



12 : 30
Twelve thirty

Write the missing numbers on the clock. Then complete the sentence.

It is half past five.

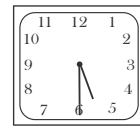

45 12345678912345678912

On index cards, write times to the hour and half hour. Place them facedown. Let children pick up cards and place them in the correct order from the time they wake up in the morning to the time they go to bed.

★ Writing the Time: O'Clock

GOAL

Practice using the word o'clock.



3 o'clock

Look at each clock. Write the time each clock shows.



2 o'clock



7 o'clock



9 o'clock



4 o'clock



11 o'clock



6 o'clock

Draw the hands on the clock to show the correct time.

5 o'clock

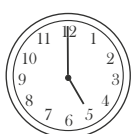

1 o'clock



12 o'clock



46 12345678912345678912

On a toy clock, let children show times that are on the hour and on the half hour. Let them practice writing in numbers and words the time they are showing.

Writing the Time: Digital ★

GOAL

Learn how to write the time on a digital clock.



Write the time shown on the left onto the digital clock on the right.



Write the time shown onto the digital clock face.

8 o'clock



six thirty



10 o'clock



Show half past ten, or ten thirty, on both the clocks.

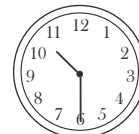



47 12345678912345678912

Write times on index cards, using a colon between hours and minutes. Cut the cards in half, using puzzle-piece lines. Mix the cards, and have children find and put together the matching pieces. Ask them to write the time revealed on each matching pair in words.



★ Using Clocks

GOAL Practice using clocks.  Jamie eats dinner at 5 o'clock. Is it time for her to eat dinner? Yes No

Circle "yes" or "no" to answer the questions below.
John starts school at 9 o'clock. Does the clock show it is time for John to start school?  Yes No

Look at the time on the clock. Is it time for math. Does math start at 10:00?  Yes No

Look at the clock. Reading starts in 1 hour. At what time will reading start? 

Sam and his mom went to the store. They left for the store at 4 o'clock. They arrived back at home at 5 o'clock.
 
How long were Sam and his mother gone? 1 minute 1 hour

Look at the clock on the right. Lunch will start in half an hour. What time will lunch start? 

Draw analog and digital clock faces, showing times on the hour and on the half hour, on index cards. Mix the cards, and let children sort the cards to match the analog clock time with its corresponding digital time.

Differences in Time ★

GOAL Learn about how long it takes to do some activities.  
The activity circled here takes more time than the other.

Circle the activity in each group below that takes more time.



Circle the activity in each group below that takes less time.



About how long does each activity take? Circle the best answer.



Discuss various other activities with children, and let them give an approximate time it might take to perform each one. As children practice assessing differences in time duration, they will become increasingly competent at judging lengths of time.

★ Days of the Week

GOAL Learn about the days in each week. These are the names of the seven days of the week in order:
Sunday → Monday → Tuesday → Wednesday → Thursday → Friday → Saturday

Circle the correct answer for each question below.
Which is the first day of the week? Sunday Saturday
Which day comes before Wednesday? Friday Tuesday
Which day comes after Sunday? Monday Wednesday
Which day comes after Friday? Tuesday Saturday

July

Sunday	Monday	Tuesday	Wednesday	Thursday	Friday	Saturday
	1	2	3	4	5	6
7	8	9	10	11	12	13
14	15	16	17	18	19	20
★21	22	23	24	25	26	27
28	29	30	31			

Use the calendar above to answer each question. Circle your answers.
What day of the week is numbered 1? Thursday Monday
What is the second Tuesday numbered? 9 16
Which date shows a ☀? 12 21
How many days are there in this month? 28 31
How many Sundays are there in this month? 4 5

For additional practice, say the name of a day of the week, then ask children to name the day that comes either before it or after it. Let children check their answers by looking at a calendar.

Months and Years ★

GOAL Learn about the months of the year.

January 31 days	February 28 days	March 31 days	April 30 days
May 31 days	June 30 days	July 31 days	August 31 days
September 30 days	October 31 days	November 30 days	December 31 days

Use the information above to answer each question.
Which month comes after January?
Which is the month with the fewest days?
How many months begin with the letter J?
How many months have 30 days?
How many months have 31 days?
Which month comes between July and September?
Which month comes before June?

In the chart above, circle the month of your birthday.
Write the month of your birthday here: _____
How old are you? years **Answers may vary**

Have children repeat after you the names of the months of the year. Then talk about the weather where you live; let them choose different months and draw pictures to show what the weather is typically like during each of those months.

★ The Muscles

FACTS

Muscles are stretchy tissues that are attached to the bones. When muscles work, they pull on the bones making them move.

TEST What You Need:



Chair



What To Do:

1. Sit on the chair. Put both hands around the top of one of your legs.
2. Flex your knee, lifting up the lower part of your leg.

3. Draw an arrow on the picture below, pointing to where you can feel the muscles move and change shape as your leg moves.
4. Stand up. Hold one arm out straight to the side and touch your upper arm.
5. Flex your elbow, lifting up your lower arm.
6. Draw an arrow on the picture below, pointing to where the muscles move and change shape as your lower arm moves.

RESULT



What do you notice about the way your muscles change as you raise your lower leg or arm?

The muscle get thicker and shorter.

The Bones ★

FACTS

Bones support and protect the body.

Read the words in the box. Use them to fill in the blanks around the skeleton below.

Elbow Knee Skull Wrist

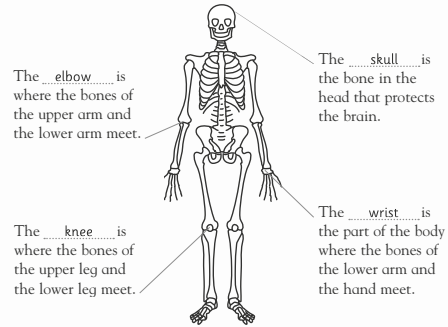

The elbow is where the bones of the upper arm and the lower arm meet.

The skull is the bone in the head that protects the brain.

The knee is where the bones of the upper leg and the lower leg meet.

The wrist is the part of the body where the bones of the lower arm and the hand meet.

Touch your head. Can you feel your skull? Circle the word that describes how it feels.

Soft **Hard**

There are lots of muscles in the body. Help your child identify some of the more obvious ones in his or her body. Knowing the proper names can be a source of pride for first graders. Start with pointing out the biceps, triceps, abdominals, calves, quadriceps, and the gluteal muscles.

Like the muscles, the bones have proper names. Show your child the skull, jaw, collar bone, and ribs. Tell your child that his or her arm has three main bones: humerus (upper arm) and radius and ulna (lower arm). And three main bones in the leg: femur (thigh) and tibia and fibula (lower leg).

★ The Organs

FACTS

An organ is a part of the body that does a special job to help keep you alive. The heart, lungs, stomach, and brain are major organs. The heart pumps blood around the body. The stomach digests food. The lungs absorb oxygen from the air you breathe. The brain is the body's control center.

Use the words in the box to write the labels for the drawing below.

Brain Heart Lungs Stomach

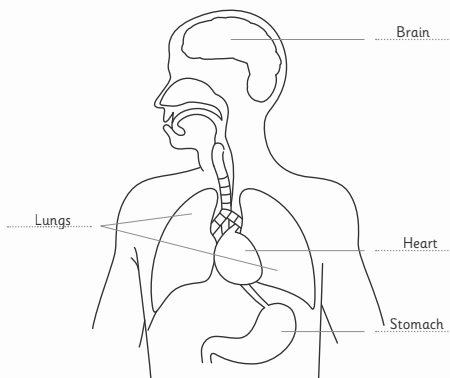

The Heart ★

FACTS

The heart pumps blood around the body. The blood travels in tubes called arteries and veins. Arteries open and close as blood passes through them. If arteries are near the surface of the skin, you can feel them opening and closing. This is called the pulse. How fast your pulse beats, tells you how fast your heart is beating.

TEST What You Need:



Armchair



What To Do:

1. Stand still for about a minute, then find your pulse by placing your fingers on the side of your neck, just underneath your jaw.
2. Sit down on the chair and relax for a few minutes. Find your pulse again. Record whether it is faster or slower than when you were standing.
3. Walk around for a few minutes, then find your pulse again. Record whether it is faster or slower than when you were sitting.
4. Run around for a few minutes, then find your pulse once more. Record whether it is faster or slower than when you were walking.

RESULT Study the results you have recorded for each activity.

Activity	Faster or Slower Pulse	What do you notice about your results?
Sitting down		Your pulse gets
Walking		faster when you
Running	Answers may vary	are more active.

This activity does not mention the largest organs in the body. The largest internal organ is the liver, which, among other things, stores fat and sugar. It also helps clean toxins from the body. The largest organ of all is the skin, which covers and protects the entire body.

Discuss with your child that the heart is made of a special kind of muscle that never gets tired. So even when they are tired, their heart just keeps pumping and pumping. By moving the blood around the body, the heart helps deliver oxygen and nutrients to the muscles and organs. It also helps remove waste products.

FACTS

Matter is the name used to describe all the different materials that make up the universe. All matter exists as a solid, liquid, or gas. A solid keeps its shape. A liquid flows, and takes the shape of the container it is in. A gas will also flow and expand and fill the container that it is in.

Answer the questions on the chart by writing Yes or No under the name of each substance named at the top of the chart. Then answer the questions under the chart.

Material	Water	Air	Penny
Will it flow?	Yes	Yes	No
Does it keep its shape?	No	No	Yes
Will it spread to fill a container?	No	Yes	No

- Which material is a solid? Penny
- Which material is a liquid? Water
- Which material is a gas? Air



FACTS

Solids do not change shape by themselves. They will not pour or spread out to fill a space.

Look at the materials shown below. Put a check (✓) in the box next to the name of each one if you think it is a solid.

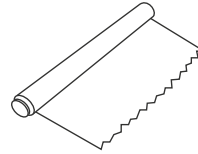

Aluminum foil ✓

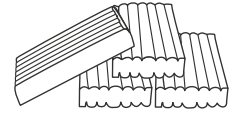

Modeling clay ✓

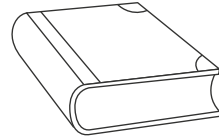

Book ✓

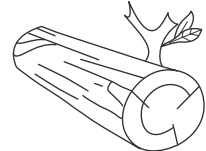

Wood ✓



Have your child list their five favorite treats. Ask them if those treats are a solid, liquid, or gas. Discuss the crossover between states: chocolate is a solid that melts into a liquid, as are ice cream and ice pops. Discuss that those liquids will then become solid again when put back in the freezer.

Continue the exercise on page 57, and have your child walk around the house naming the solids that they see. Have them record the solids they see on a chart.

FACTS

Liquids will flow, and take the shape of whatever container they are in. They can also be poured. Some liquids flow faster than others.

TEST What You Need:

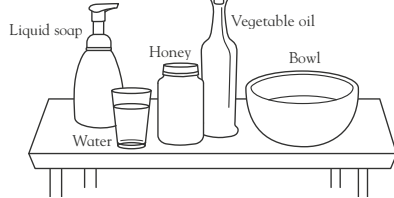

What To Do:

- Pour a small amount of the liquid soap into the bowl. How quickly did the soap pour? Now pour a small amount of water. How quickly did that pour? Repeat with the honey and vegetable oil.
- Make note of which liquid poured fastest and which poured slowest.

RESULT

Liquid that pours fastest Water
 Liquid that pours slowest Honey



Pour some water into a pitcher. Show your child that the water is now in the shape of the pitcher. Then pour the water into a bowl. What shape is the water now? Pour the water into a glass and then into a rectangular container. Reiterate that liquid changes its shape according to the vessel.

FACTS

Some solids mix into liquids so that the solid seems to disappear. The solid dissolves into the liquid. This happens when you mix sugar into water. You can no longer see the sugar, but you know it is there because the water tastes sweet. Salt is another solid that dissolves in liquids. But some solids, such as pebbles or rice, will not dissolve.

Look at the pictures below. Each one shows a solid next to a liquid. Circle the two solid and liquid pairs where the solid will dissolve into the liquid.

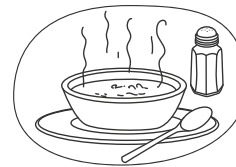

Soup and salt



Water and rice

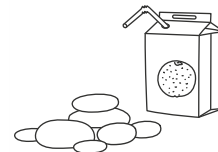

Juice and pebbles

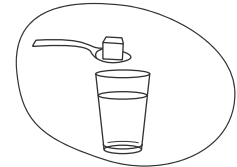

Water and sugar



Have your child identify three solids that they would like to try to dissolve in water (such as sand, toys, pasta, cocoa powder, flour, dirt, etc.). One at a time, put the solid into a bowl of water and stir. Record the results on a chart.

★ Heat and Dissolving

FACTS

How hot or cold a liquid is can make a difference to how quickly a solid will dissolve in it.

TEST What You Need:

Cold water Warm water Very warm water Sugar

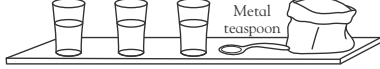

What To Do:

1. Take three glasses. Fill one halfway with cold water, another with warm water, and the third with very warm water.
2. Stir a teaspoon of the sugar into the cold water, counting how many times you have to stir until the sugar has completely dissolved. Make a note of the number of stirs on the chart.
3. Repeat Step 2, stirring a teaspoon of sugar into the warm water. Again count and note the number of stirs it takes for the sugar to completely dissolve. Repeat again, stirring sugar into the very warm water.

RESULT Look at your results on the chart and answer the question.

Water at Different Temperatures	Number of Stirs
Cold water	
Warm water	
Very warm water	Answers may vary

Does the sugar dissolve faster as the water gets hotter? Yes.....

Gases ★

FACTS

Air is a mixture of invisible gases. You cannot see it, but you can feel it blowing on a windy day. Just like solids and liquids, gases have weight, and some gases are heavier than others. A balloon filled with a light gas will float up higher than a balloon filled with a heavier gas.

Look at the picture below. The balloon with the swirly dots is filled with a very light gas. The stripy balloon is filled with a heavier gas. The balloon with the clouds on it is filled with the heaviest gas.



1. Point to the balloon with the heaviest gas.

2. Point to the balloon with the lightest gas.

3. Is the stripy balloon heavier or lighter than the balloon with the swirly dots?

..... Heavier.....

Reward your little scientist by repeating this activity using powdered hot cocoa or soup or other dissolvable treat. Discuss at which temperature the items dissolve best, and then help your child prepare their treat.

The concept of gas can be abstract for a first grader. Blowing up balloons is a helpful way of showing your child how gas (the air from your lungs) will fill a balloon, not just pool at the bottom, the way a liquid would (as with water balloons). Bubbles are also a good example.

★ Water

FACTS

Water is usually a liquid, but it can also exist as a solid or gas. When you put water in the freezer, it turns into a solid by becoming ice. When your mom or dad boils water on the stove, it turns into a gas by becoming steam.

Look at the images below. Circle the images where water is a liquid. Make a square around the images where water is a gas. Make a triangle around the images where water is a solid.

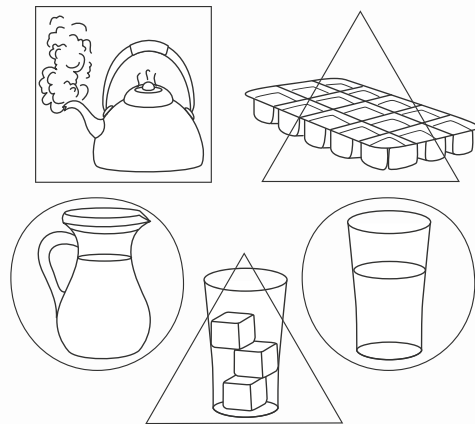

Weather ★

FACTS

Scientists can tell us what kind of weather we are likely to have in the days and even weeks to come. This helps us prepare for our day, and choose what to wear (and bring) when we go out.

Look at the four scenes below. Then look at the clothes. Draw a line between each scene and the best clothes for the weather shown.

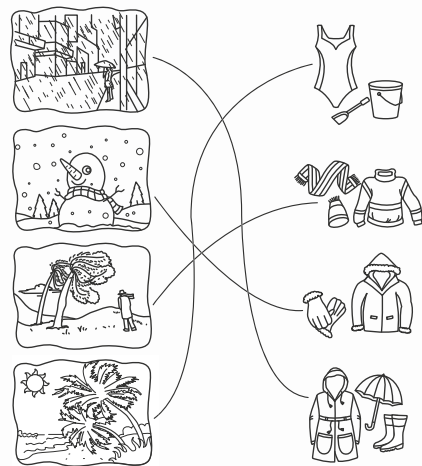

To illustrate water becoming a solid, have your child choose a few small freezer-safe containers. Help them pour some water into each one, and place them in the freezer. After three or four hours, pull the containers out, and discuss what happened to the water.

Weather changes daily around the world. With your child look in the newspaper or online to find out the weather in five cities around the world. Discuss what preparations people in each city will need to make for the day's weather. Will anyone need an umbrella? Snow boots? Sunglasses?