

METALWORKING



Introduction

Making a living from a small-scale metalworking depends on being able to make products that customers want. So it is important to find out what people are looking for. It is also important to make good quality items that will not fail, and it is important to get the price right.

This technical brief looks at some of the basics of running a small-scale metal fabrication workshops within developing countries.

Metal can be manipulated in a number of ways from casting, blacksmithing or forging to machining and joining to produce all manner of tools and equipment.

Small scale metal workshops

In many developing countries much of the metalworking takes place by the roadside in the open. In Kenya this type of unofficial enterprise is called Jua Kali which means in the sun shine in KiSwahili.

The Practical Action (previously known as ITDG) Jua Kali Project was set up to work with small-scale artisans in the informal sector to create employment & income generating opportunities.

In many instances the equipment that these workshops have available to them is limited. To address this limited access to manufacturing equipment Practical Action has set up tool hire workshops that allows small-scale metal workshops to use expensive equipment such as lathes, drills, and milling machines



Figure 1: Kennedy Otieno repairing a sugar crusher for jaggery production. Migori, Kenya
Photo credit: Practical Action/Morris Keyonzo

How to make metal products

Casting

Small-scale foundries often start by casting aluminium as the temperatures required are much lower. An outline of small scale casting in developing countries is described in the Practical Action Technical Brief *Casting*

Blacksmithing

Forging or blacksmithing is one of the oldest methods of making objects from metal. An outline of blacksmithing is described in the Practical Action Technical Brief *Blacksmithing*. The main item required is a forge where the metal can be heated. The other basic requirements are an anvil, a hammer, and some tools to hold the metal while it is being worked.

An example of the type of product produced is described in the Practical Action Technical Brief *The Donkey Plough*.

Tinsmithing / Sheet metalwork

Sheet metal work is the process of producing such objects as buckets, boxes, tanks, drums, cupboards, desks, ducting, vehicle bodies, etc, from sheet metal. Traditionally tin was commonly used which gave its name to the process but now steel is often used. In developing countries scrap car bodies are a common source of material.

Tinplate, used for making articles such as funnels, where economy of material combined with ease of working are required, is usually in the thickness range of 0.3 to 0.8 mm. Thickness of galvanized steel in common use range from about 0.7 to 2.5 mm. Aluminium, copper, brass and uncoated steel sheet are used in thicknesses from 0.3 to 3 mm.



Figure 2: Examples of the some of the tin products produced by the trainers who carry out training in tinsmithing by Practical Action Bangladesh.

Photo credit: Practical Action/Zul

Metal folding and bending

The simplest approach to use a hammer and anvil to produce the shapes you want. Various designs of low cost folding and bending equipment have been developed by Apt Design & Development based on practical experience.

Folding machines work on a variety of principles. For general purposes, such as folding sheet metal to make a box, a box-and-pan type machine is convenient. This consists of a flat table, a clamp to hold down the sheet, and an edge that folds up or down to force over the projecting edge of the sheet. Various configurations are used to allow the bending of intricate shapes such as internally flanged boxes. Another form of bending machine, an angle bender, works by forcing the sheet into a V notch by the action of a blade applied by hand lever or by power. These machines are less versatile but once set up for a particular job, can be quicker in use than a folding machine.

[How to Make a Folding Machine for Sheet Metal Work](#) *Workshop Equipment 1*
Rob Hitchings, [ITDG Publishing](#)

Bending rollers are used to make drums and pipes. They consist of three horizontal rollers, one above the other two, arranged so as to bend continuously a sheet fed through them. The top roller is adjustable in height to set the radius of curvature of the bend. The rollers are driven either by a handwheel or by power.

[How to Make a Rolling Machine for Sheet Metal Work](#) *Workshop Equipment 3*
Rob Hitchings, ITDG Publishing

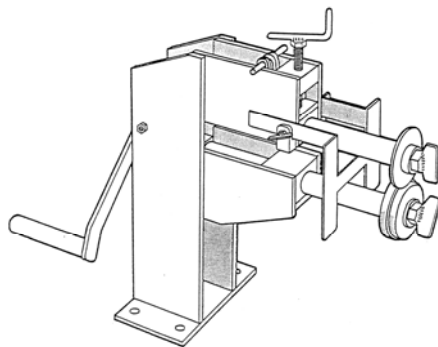

Figure 3: A Jenny for sheet metal work. Designed by Graham Saunders. Illustration by Graham Saunders

Specialised bending machines, particularly used by tinsmiths, include burring machines (usually called jennies), which are used for flanging the ends of containers in preparation for

wire edging or for making a folded seam; wire rolling machines, for rolling down the edge of a sheet over edging wire; and beading machines, which, by rolling the sheet between shaped rollers, raise a bead round, for example, a drum. Combination machines are available, which will carry out several tinsmiths' operations (flanging, beading, wire rolling, crimping, etc), by interchanging rollers.

If you are going to perform a particular action on a regular basis such as creating ridges in the metal it is worth getting some extra equipment. This could be as simple as a low cost jenny. See the Practical Action Technical Brief *How to make a strengthening ridge in a bucket*

[How to Make a Metal-bending Machine](#) *Workshop Equipment 10*
R.D. Mann, ITDG Publishing

Three dimensional bending can be carried with a press and dies. A 5-ton fly press can be used to stamp items such as small electrical switch covers. Dies can be made of wood, zinc-based alloy, mild steel, or hardened steel. It is also possible to use a rigid die in conjunction with a rubber block. Presses are best suited to batch production. For one off items, hammers and a variety of dollies which are held behind the sheet being worked can be used.

Pipe Bending

Various low-cost approaches can be applied to this process as demonstrated in the following two documents.

See the Practical Action Technical Brief *Pipe Bending*

[How to Make a Pipe-bending Machine](#) *Workshop Equipment 5*
Michael Walsby, ITDG Publishing

Cutting and machining

Cutting can be done with a hammer and cold chisel, which is hard work but often preferable to saws that wear too quickly.

Another common method is flame cutting if welding equipment is available.

Tinsnips are used for light work on thin material (up to about 1 mm steel or 1.5 mm on softer metals). They are cheap and versatile, but slow, and tend to buckle the edges of the cut metal.

Various patterns of snips are available, some intended for cutting deeply into large sheets and others made more manoeuvrable within the cut. Some have straight blades, and others, intended particularly for cutting holes and curved edges, have curved blades.

Hand lever shears bolt to a bench or a stand, and are of greater capacity than tin snips (e.g. 3 mm steel). Their use is generally, restricted to straight cuts, although it is possible to trim the edges of a sheet to a convex curve by successively cutting thin strips from the corners. They can be used to cut to a point on a sheet, rather than being restricted to cutting right across, and so can be used, for example, to cut out squares from the corners of a sheet in preparation for folding into a box. Having the shearing action of a pair of scissors, they tend to distort the cut edges.

However, this difficulty is overcome in one type of machine, in which the sheet lies flat on the table, and a narrow strip is sheared out along the line of the cut.



Figure 4: Flame cutting. Practical Action organised training for Asaduzzman Munshi in welding. As a result he has now started a small metal workshop of his own, earning Tk 3000 monthly (2000). In the process of cutting parts for a three-wheel rickshaw structure.

©Practical Action/Zul

[How to make cutting shears for sheet metal](#) *Workshop Equipment 4*
Rob Hitchings, ITDG Publishing

Guillotines are arranged to cut across the entire width of a sheet, and can be treadle operated (typically with a capacity of 1 m width and 1.5 mm thickness, or power operated). These machines are quick and accurate in use, and leave clean-cut edges practically free of distortion. They are used universally for the preparation of straight-sided shapes, except where cuts into, but not right across, the sheet are needed.

Holepunch

[How to Make a Hand-operated Holepunch](#) *Workshop Equipment 7*
Ted Stone and Jim Tanburn, ITDG Publishing

Drilling

[How to Make a Foot-operated Workshop Drill](#) *Workshop Equipment 2*
Paul Smith, ITDG Publishing

Lathes and milling machines

Machines such as lathes and milling machines are an expensive investment for a small metalworking enterprise and so are not discussed in this technical brief. They can, however, vastly improve the quality and versatility items that can be made providing the ability to make screws and gears.

Jointing

The jointing processes used on sheet metal include:

- Folding and seaming
- Riveting
- Soldering
- Brazing
- Welding

Folding and seaming,

The edges are folded over each other, is used particularly by tinsmiths, and in the volume production of thin sheet metal parts. A jenny or folding machine is used to make the folds, and then with either a seaming machine or a hammer the folds are closed together to make the seam. The seam can be sealed if necessary with soft solder, or by hot dip galvanizing the finished product.

Rivets are usually set by hand using a hammer and appropriate sets. The technique is low in capital but takes time and skill. However, pop-riveting, in which a hand held tool is used to set a hollow rivet, much quicker, as it requires access from only one side of the job. The cost of the pop-rivets, which are made to suit the type of setting tool ("gun") are expensive. Except for the jointing of aluminium and pre-coated steel, riveting has mainly given way to welding.

Soldering is used largely in tinsplate and copper and brass, although it can be used on galvanized and bare steel. It is not usually used for aluminium, as powerful fluxes are necessary. The process consists of running molten solder into the joint, using either a flame or a heated iron (made of copper) to heat the joint while the solder is applied. Cleaning and the use of flux are necessary to enable the solder to take. Fluxes can be proprietary, or zinc chloride can be used. This is made by dissolving zinc in hydrochloric acid (spirits of salts) until the action ceases. A little extra acid added after bottling improves the cleaning power of the flux.

Brazing is a process similar to soldering, in principle, (and is often called hard soldering). Instead of using soft solder (melting point 200°C), brass is used (melting point 900°C). Flame heating is almost always used, although the use of a forge is possible. A gas-air torch or a powerful paraffin blowlamp is convenient sources of heat, as is oxyacetylene equipment if it is available. As flux, proprietary preparations and borax are equally effective.

A brazed joint is often as strong as the surrounding metal, and in copper work especially it is an excellent and neat joint.

Welding is the most generally used jointing process. It consists of melting together the joint edges and allowing the result to solidify, with or without additional (filler) metal.

Oxyacetylene equipment is the most versatile, as it can be used for welding, brazing, cutting and heating. Steel down to about 0.5 mm can be welded and gaps filled easily, but distortion tends to be a difficulty because of the somewhat diffuse heat. The main expenses are in the rental of the cylinder and the supply of the gases. The need for a nearby supply network limits the usefulness of the oxyacetylene process to industrialised areas.

Metallic arc welding ("stick welding") is economical and versatile. A transformer type welder of 180 amps, will weld steel of thickness between 1.5 and 10 mm relatively easily, and with care it is possible to weld steel outside this range of thickness. With special electrodes other ferrous metals can be welded with this equipment. A welding generator with D.C. output can weld all metals in common use, but the equipment cost is much higher. Consumable electrodes are the main material expense.

With a carbon arc torch, an arc welder can be used on jobs normally tackled with oxyacetylene equipment, but the stability of the arc flame tends to be poor, making it difficult to weld thin material. However, for brazing, it is quite adequate.

Contact Practical Action Southern Africa for a design of a low-cost welding machine.

Finishing

Any product will look much more attractive if a suitable finish has been added and it will be easier to sell. There are a number of finishes that can be applied to metal products. In most cases, the finishes will help protect the product from corrosion. The simplest is to paint them. Other finishes are:

Galvanising

Galvanising of steel is done by emersion into a bath of molten zinc which will chemically bond to the surface. This protects the steel from corrosion. See the Practical Action Technical Brief *Galvanising*.

Electroplating

Electroplating produces a deposited layer of metal onto a product by the application of an electric current so a suitable solution. See the Practical Action Technical Brief *Electroplating*.

Enamelling

Products can be given a hardwearing but attractive finish by enamelling them. Once the product has been coated then it needs to be heated in a kiln.

Quality control

When working in a small workshop there are certain principles that will help in producing a good product.

Plan the sequence of manufacturing

So that all the accurate surfaces are machined at one setting

The finished surfaces are not held in a vice or chuck

Take care over marking out and measuring

Parts that accurately made add quality to a product. Measuring at every stage of manufacture ensures that errors are seen early on when they can be put right. Time spent marking out is not a waste of time.

Remove all Burs

Burs are the rough edges created when metal is cut. These should be removed from edges and holes

Don't use emery cloth to hide inaccurate work

If the surface finish of a product is bad it means the tool is in bad condition, it is blunt, the wrong shape or being used at the wrong speed.

Learn to weld properly and make strong welds

A good weld will be strong and will not need dressing. Dressing a poorly welded joint can hide the weakness of the join and can cause problems later on.

Finishing

Finishing is very important and a good finish will help sell the product but it should not be used to hide bad work. No amount of paint can make a bad product look good.

Product development and design

The products need to be attractive to potential customers. This can be achieved by making items of high quality, that are attractive, that are affordable and address customers needs. Practical Action has developed a range of products, for example Practical Action Southern Africa has developed the following items.

- Peanut Butter Machines
- Peanut Roasters, Shellers
- Manual and Automatic Freezit Machines
- Bag Sealers, Beehives
- Manual, Electric Oil Press Machines
- Electric Gravity Maize Mills
- Cyclone Maize Mills, Diesel or Electric
- Dehullers, Diesel or Electric
- 21hp Diesel Engines
- Electric Motors
- Star Delta Starters
- Double Cavity Brick Press
- M C Roof Tile Machines
- Brick Moulds, Block Moulds
- Candle Moulds
- Four Colour Screen Printers
- Welding Machines 110, 140, 225amp



Figure 5: A large hand grinder produced by Practical Action Southern Africa.

Photo credit: Practical Action / Zul

Practical Action Business Shop
 216 Willowvale Road
 P O Box 1744, Harare
 Zimbabwe
 Tel: +263 (0)4 669773/4
 Email: itbshop@icon.co.zw

How to make a door bolt

The methods of construction uses a die and swage that enables that shape of the bolt casing to be made uniformly and accurately.

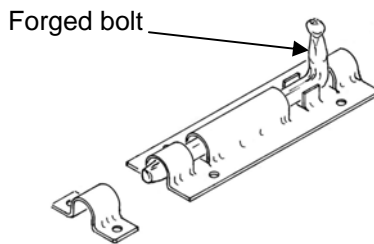

Swage
(Made by a blacksmith)

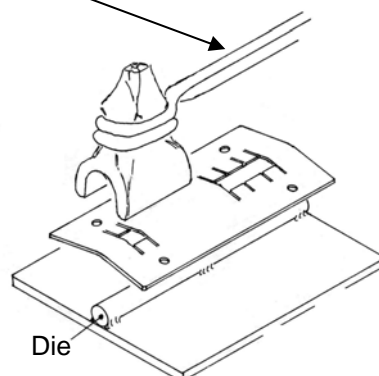

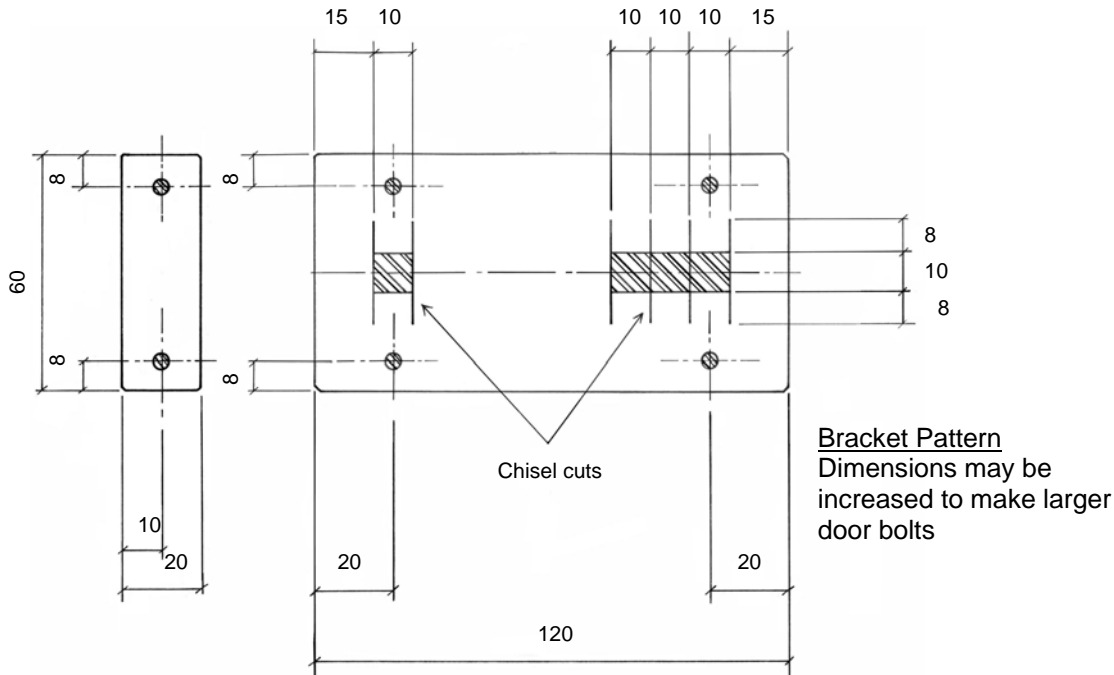

Running your business

With a business there are certain basics that you need to get right if you are to make a profit. This is equally applicable to small metalworking enterprises as much as any other business. See the Practical Action Technical Brief *Running a Business*

References and further reading

- *How to Make a Folding Machine for Sheet Metal Work – Workshop Equipment 1*
Rob Hithings, ITDG Publishing
- *How to Make a Foot-operated Workshop Drill Workshop Equipment 2*
Paul Smith, ITDG Publishing
- *How to Make a Rolling Machine for Sheet Metal Work – Workshop Equipment 3*
Rob Hithings, ITDG Publishing
- *How to Make Cutting Shears for Sheet Metal – Workshop Equipment 4*
Rob Hutchings, ITDG Publishing
- *How to Make a Hand-operated Holepunch – Workshop Equipment 7*
Ted Stone and Jim Tanburn
- *How to make a Metal-bending Machine – Workshop Equipment 10*
R.D. Mann, ITDG Publishing
- *How to Make a Jenny for Sheet Metal Work* Graham Saunders, ITDG 1985
- *Designing for Small Workshops* [Appropriate Technology Journal](#) Vol. 12 No. 4 March 1986

Useful addresses

Apt Design & Development
29 Northwick Park
Blockley
Nr. Morton-on-Marsh
Gloucester
United Kingdom
Tel: +44 (0)1386 700130
Fax: +44 (0)1386 701010

E-mail: apt.enterprise@dial.pipex.com

Website: <http://dSPACE.dial.pipex.com/apt.enterprise/>

APT is an organisation that promotes small enterprise development.