

30

**AT** MICROFICHE  
REFERENCE  
LIBRARY

A project of Volunteers in Asia

IT Granule Applicator

ITDG Agricultural Equipment and Tools No. 30

Published by:

Intermediate Technology Publications, Ltd.  
9 King Street  
London WC2E 8HN  
United Kingdom

Paper copies are 0.50 British pounds.

Available from:

Intermediate Technology Publications, Ltd.  
9 King Street  
London WC2E 8HN  
United Kingdom

Reproduced by permission of Intermediate  
Technology Publications, Ltd.

Reproduction of this microfiche document in any  
form is subject to the same restrictions as those  
of the original document.

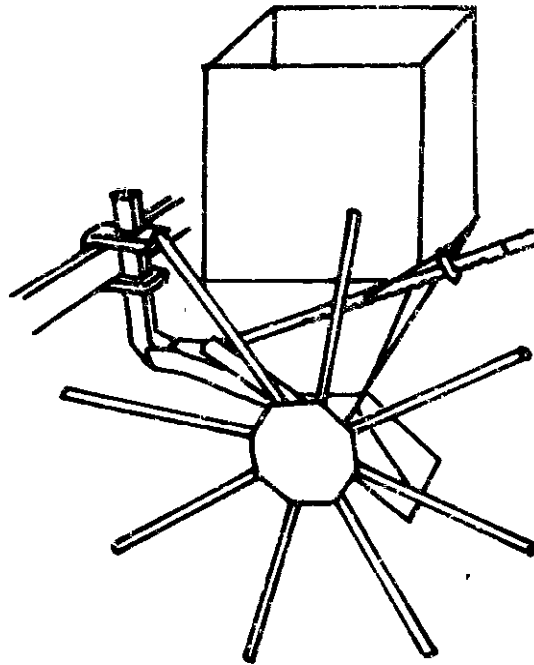

I.T. GRANULE APPLICATOR  
(DAUDAWA, N.C.S. NIGERIA)

DESIGN: JOHN BOYD

DRAWING: BERNARD WINLO

## I.T. GRANULE APPLICATOR

Developed by : Intermediate Technology Project, Daudawa,  
North Central Nigeria.

Introduction : The granule applicator was developed as part of the I.T. Farm Equipment Development Project work programme attached to the Institute of Agricultural Research of Ahmadu Bello University.

The I.A.R. Agronomy Department requested development of an applicator for fertiliser granules into which herbicide had been incorporated, the granules to be spread in a 15 cm wide band on top of the ridges to control weeds in the crop rows while the inter-rows were mechanically weeded.

A Planet Junior hand-pushed seeder was modified to spread a band of granules by replacing its seed tube with a fan-shaped outlet.

A similar Planet Junior-based applicator was fitted to an Ariana toolbar and a simple direct drive from a spiked wheel was used to replace the original bevel gears and shaft drive to the metering mechanism. Standard Ariana soil moving components were added to enable a ridge to be built and granules to be applied, either on the surface or incorporated into the soil, simultaneously.

A simpler, more robust applicator with a larger hopper capacity was built from locally available mild steel sheet, water pipe and reinforcing rod, using normal hand tools and welding equipment, and fitted to an Ariana toolbar. It was found to be capable of spreading superphosphate granules in a 15 cm wide band at rates between 10 kg and 500 kg per total hectare on the 75 cm spaced rows used in the Daudawa area.

### Description :

In the drawings which follow, dimensions are given in inches with millimetre equivalents in brackets.

- Page 1. Pictorial views of assembled granule applicator.
- Page 2. Hopper unit, side view.
- Page 3. Hopper unit, rear view.
- Page 4. Hopper unit, plan view.
- Page 5. Metering mechanism.
- Page 6. Granule aperture flow adjuster.
- Page 7. Ratchet lever for flow adjustment.
- Page 8. Granule-flow drive, front view.
- Page 9. Granule-flow drive, side view.
- Page 10. Granule distribution spout, plan and side views.
- Page 11. Granule distribution spout in position, side view.
- Page 12. Calibration chart for I.T. granule applicator.

The applicator hopper A is made of 3/32" (2.4) thick mild steel sheet, and to increase its capacity it was extended vertically by 9" (229) using 1/16" (1.5) mild steel sheet as indicated by B.

The hopper support frame pieces C of 1" x 1/8" (25 x 3) mild steel, are welded to the attachment stalk D which is fabricated from 1" x 1" (25 x 25) angle iron and allows the applicator to be clamped firmly to an Ariana toolbar E.

The first part of the metering mechanism is made of 1 1/8" (28) internal diameter pipe F welded to the bottom of the hopper. The granule flow adjuster G of 1 1/16" (27) outer diameter pipe, which fits inside the pipe F, is provided with bearings of hardwood at both ends as indicated by H.

Even granule flow is maintained by the rotating movement of the agitator J which, when passed through the wooden bearings within pipe G, is provided with a distance piece K of 1/2" (12.5) bore pipe, washers L, and a split pin M. The integral agitator J and granule flow drive N is made from 7/16" (11) mild steel bar, rotation being by ground-drive from the "spiked-wheel" N.

The granule spout P is made from 1/8" (3) thick mild steel, and even granule spread is accomplished by the provision of diverter pegs made of wire and positioned within the spout as shown at Q.

With reference to pages 7 and 12, the rate of application of granules per unit area is controlled by the position of the flow adjustment ratchet lever R. The ratchet teeth are at 1/4" (6.3) spacing, and to provide finer adjustment two holes are provided ("A" and "B") on the lever at the point where it joins the metering sleeve arm S. To keep the ratchet engaged during field operation, a small coil spring is fitted through 3/8" (3) diameter holes between the metering sleeve arm and the ratchet lever.

These drawings and description should be sufficient to enable the recipient to construct an applicator. However, materials used will depend on what is available and the constructor is advised to determine availability and alter dimensions accordingly. He is also welcome to alter the design to suit local conditions.

①

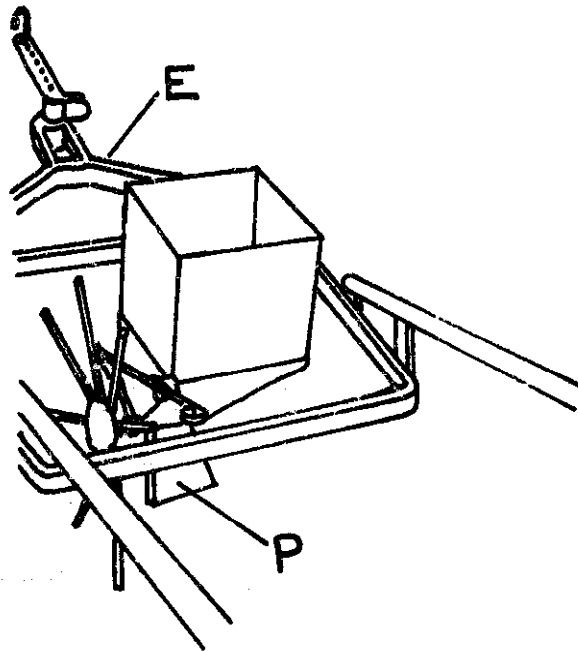
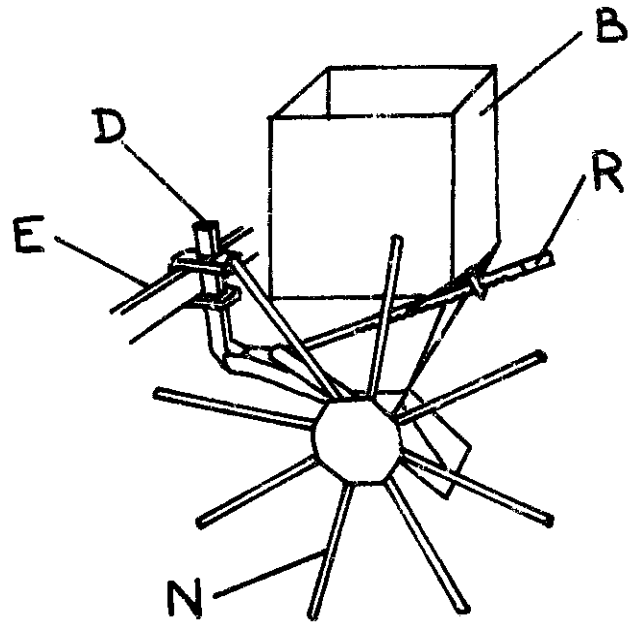
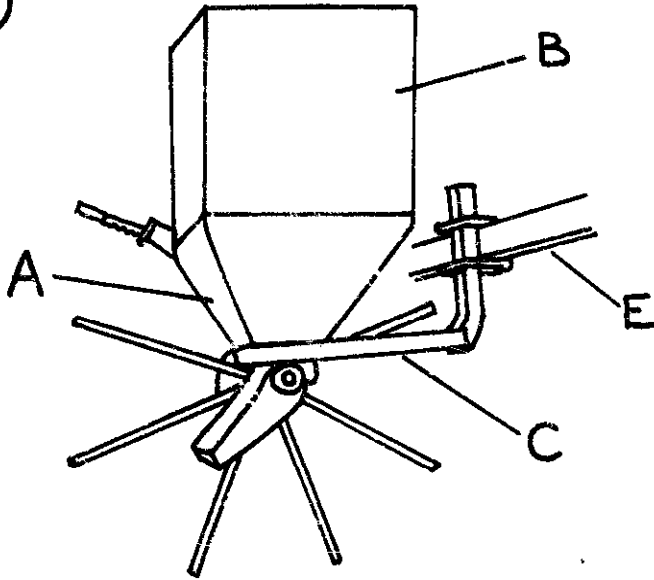

2

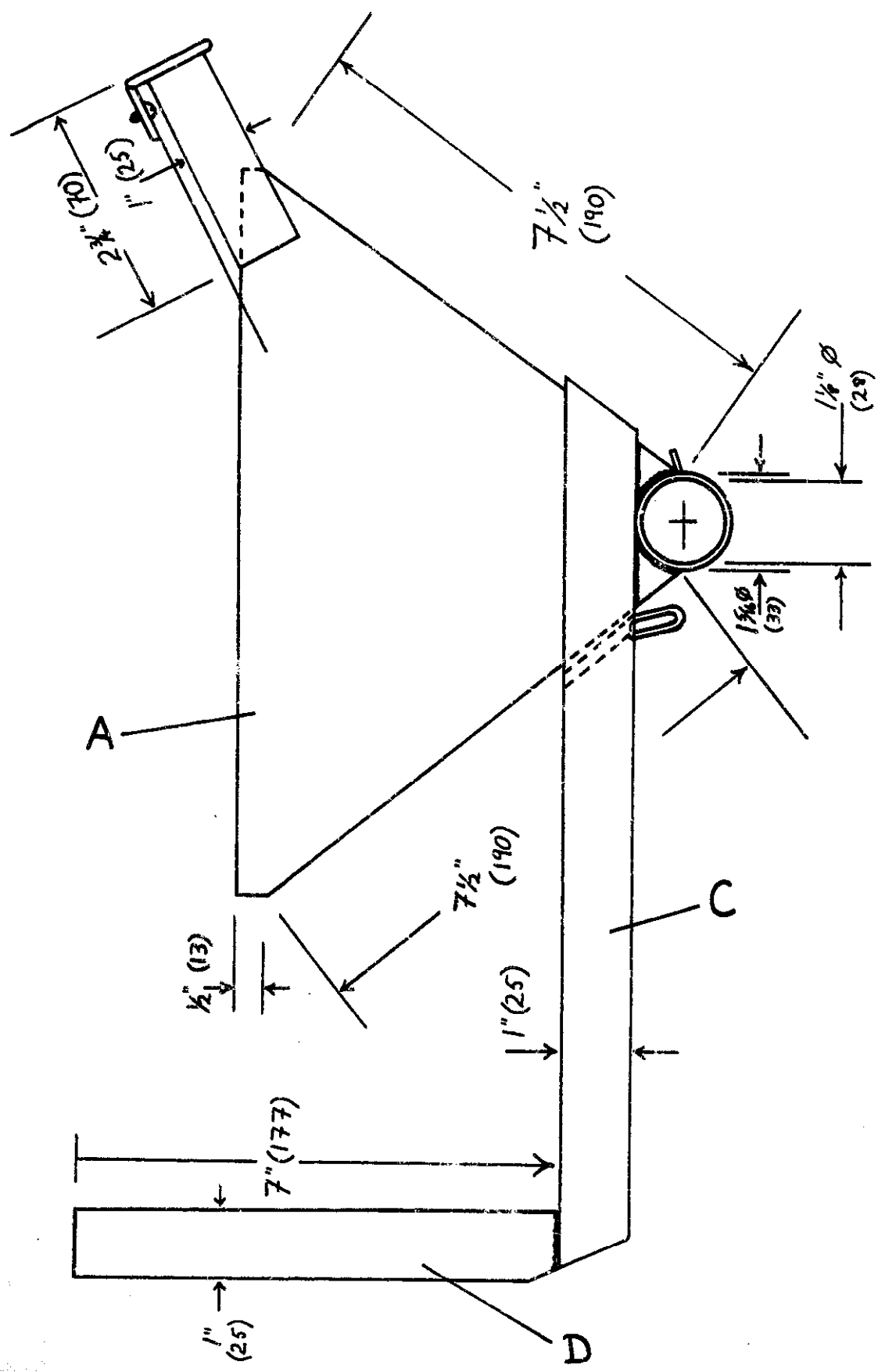

3

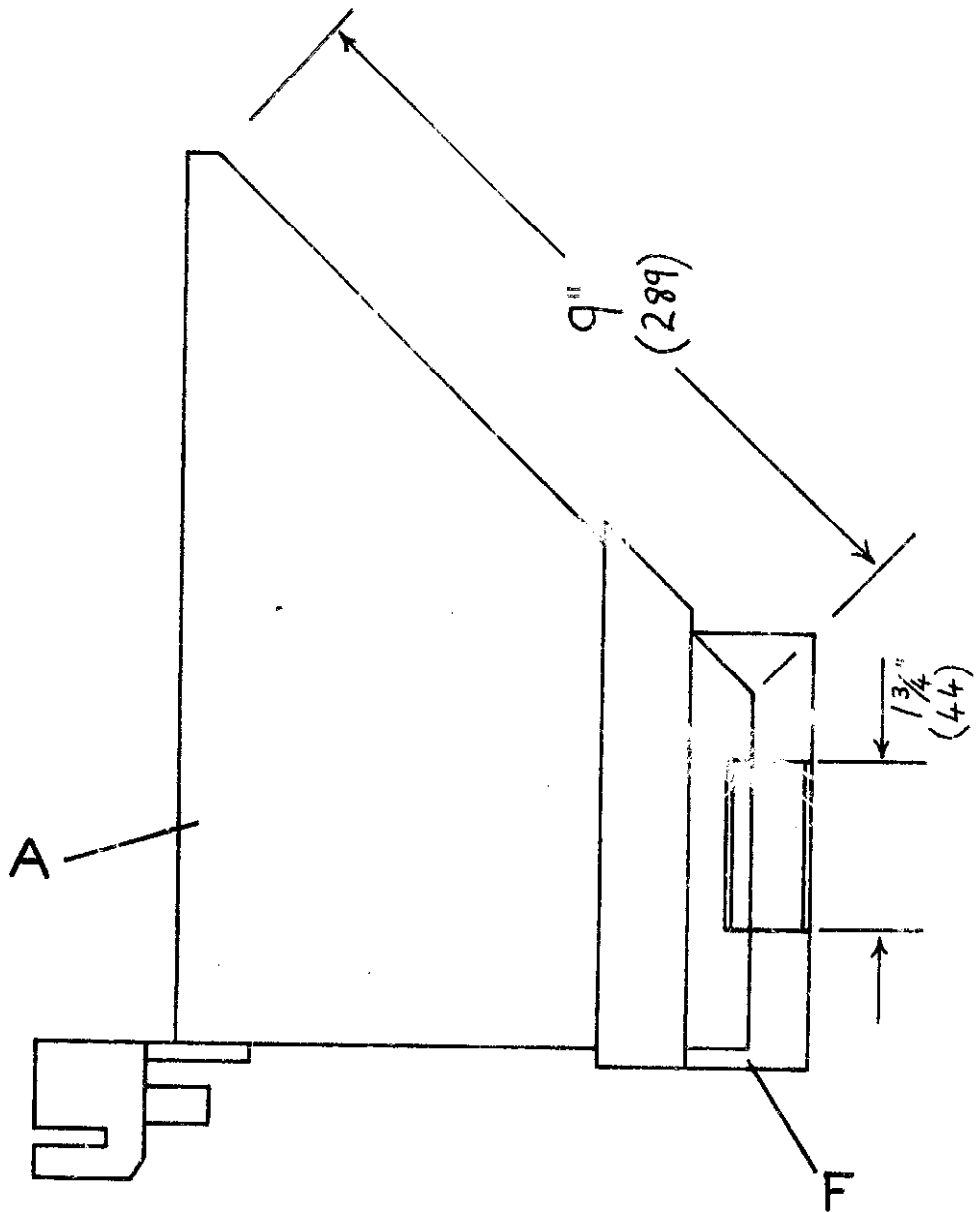



4

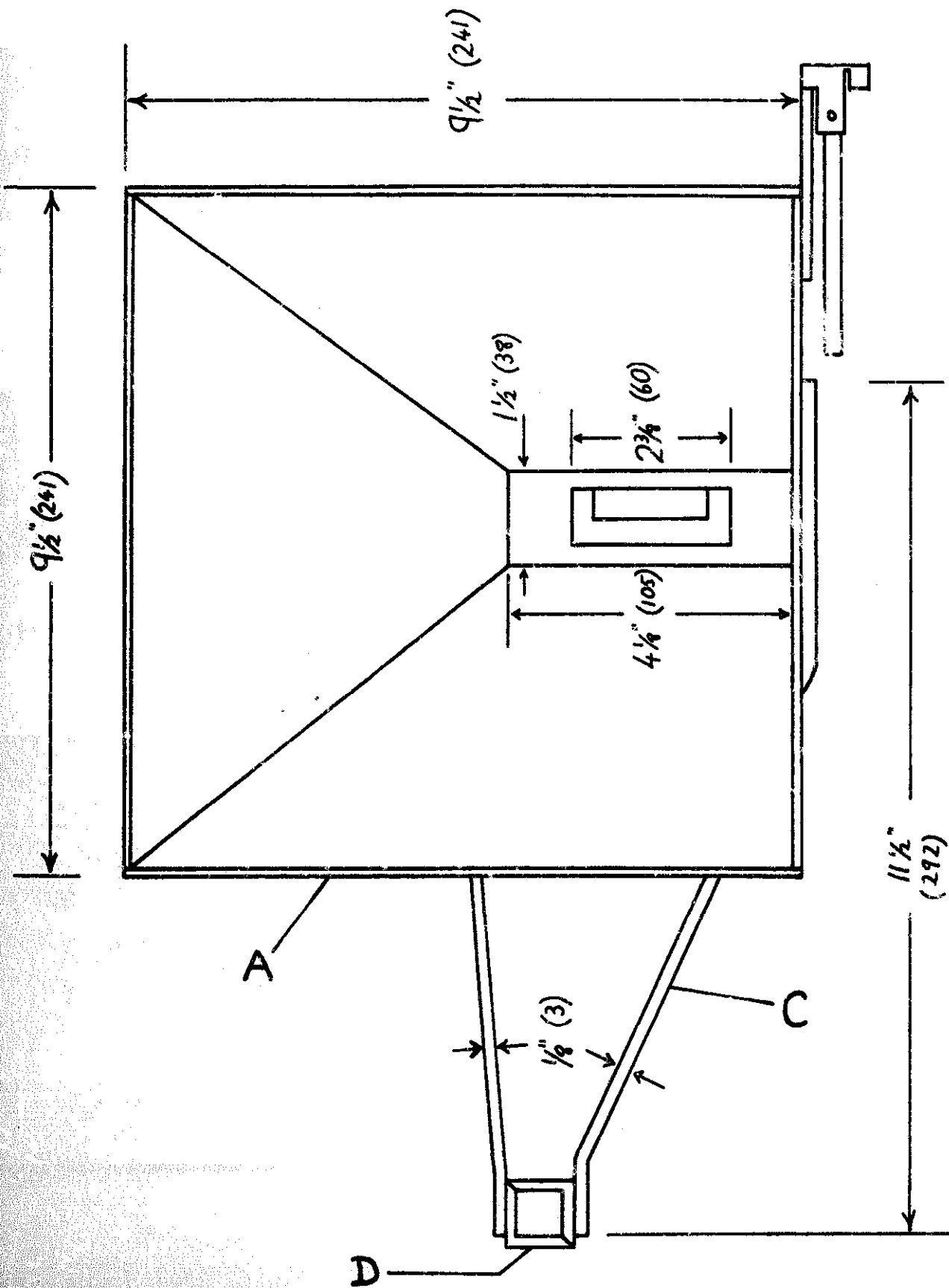

5

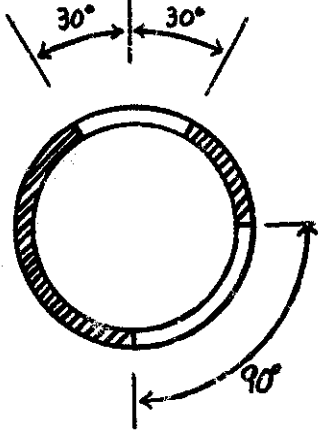

Y-Y

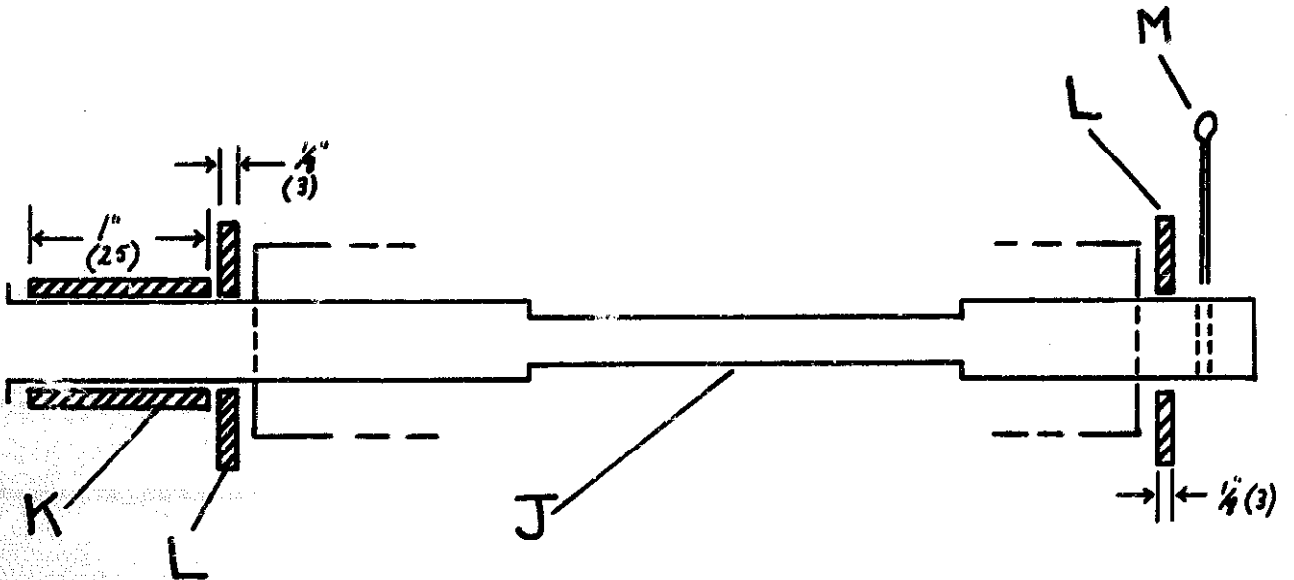
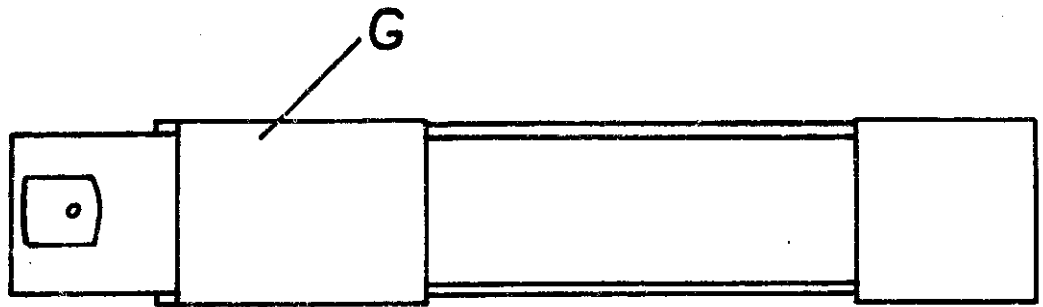
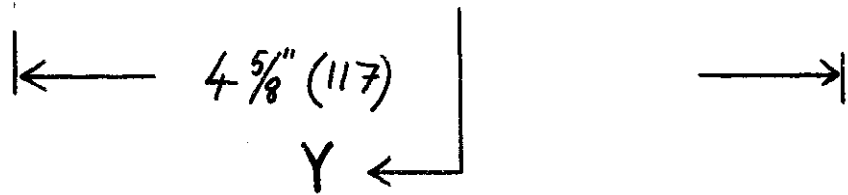
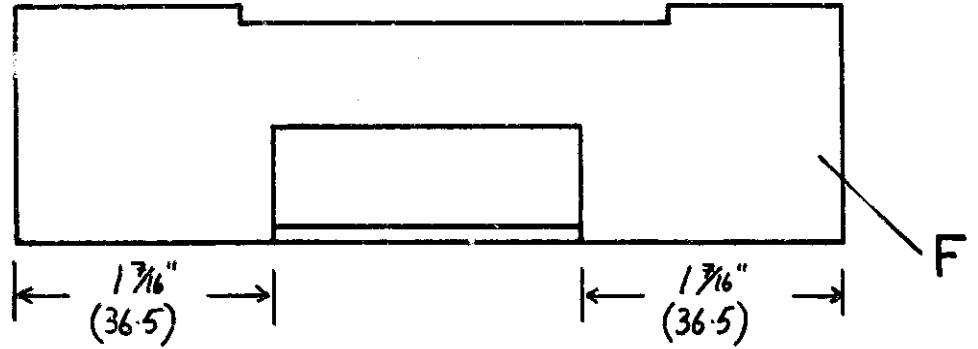
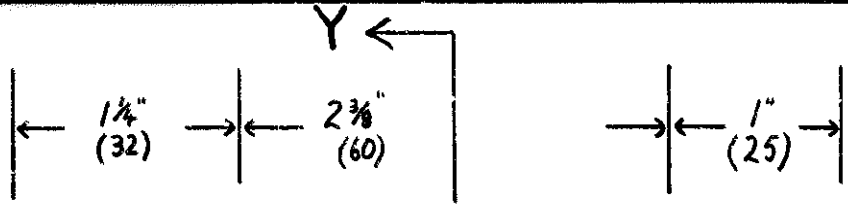

6

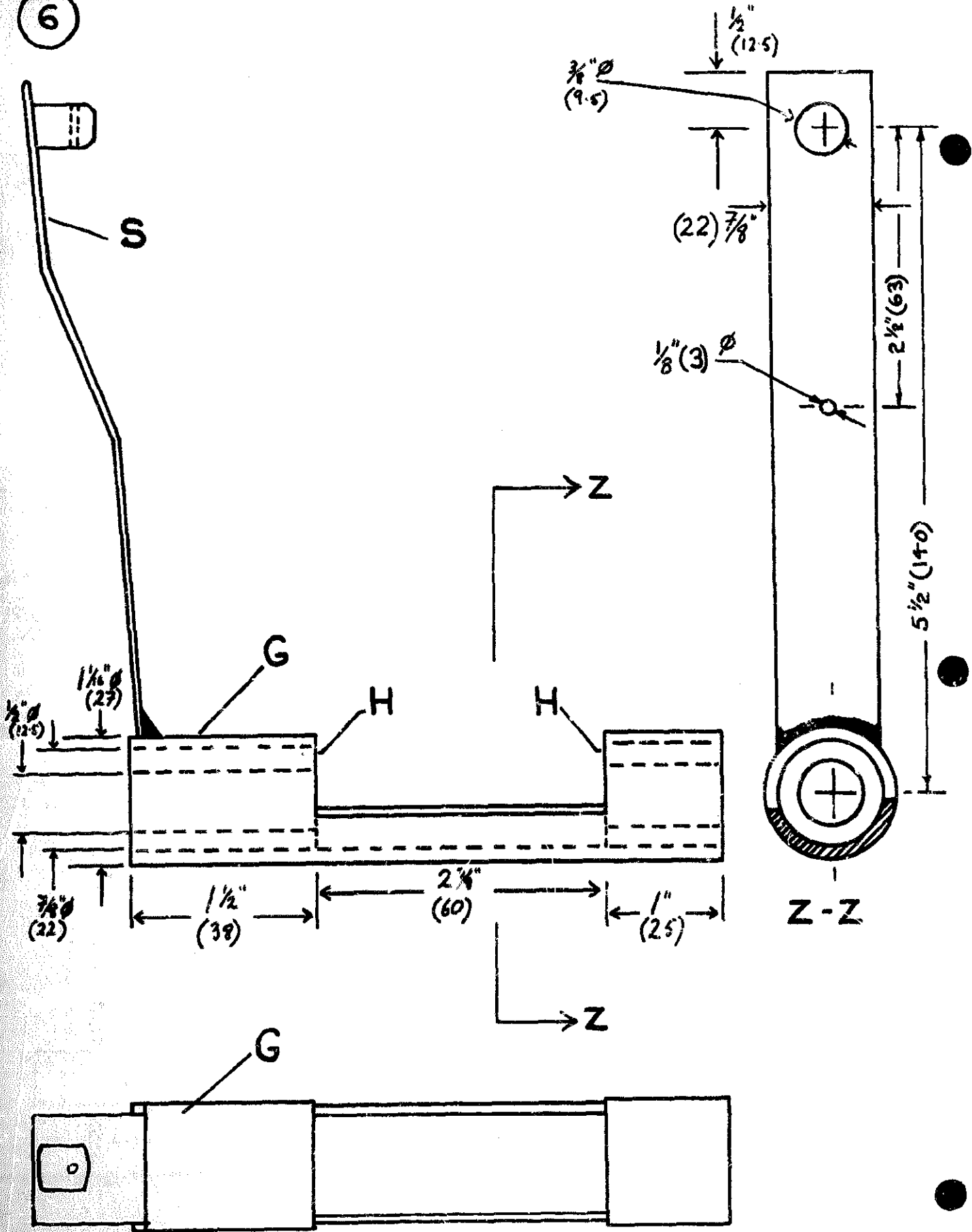

7

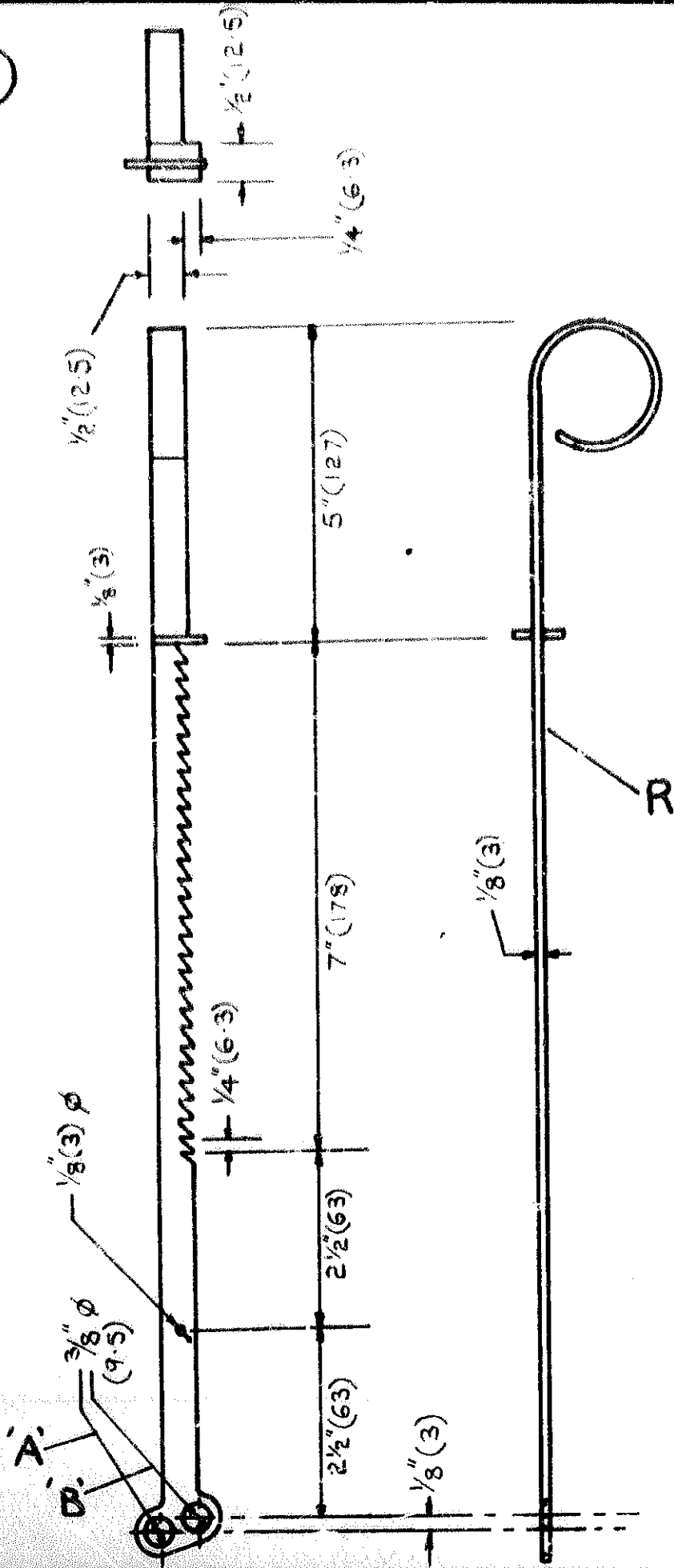

8

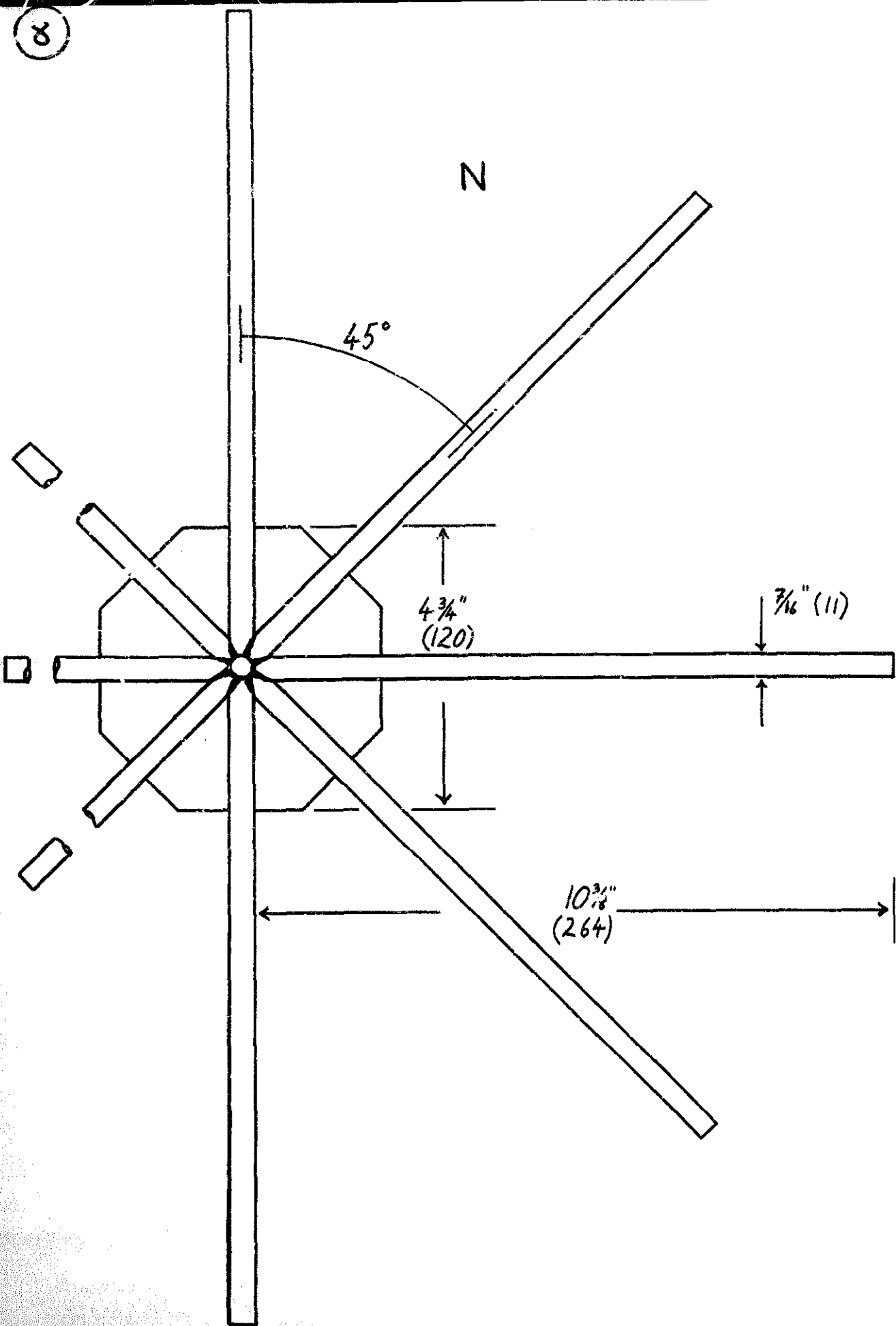

9

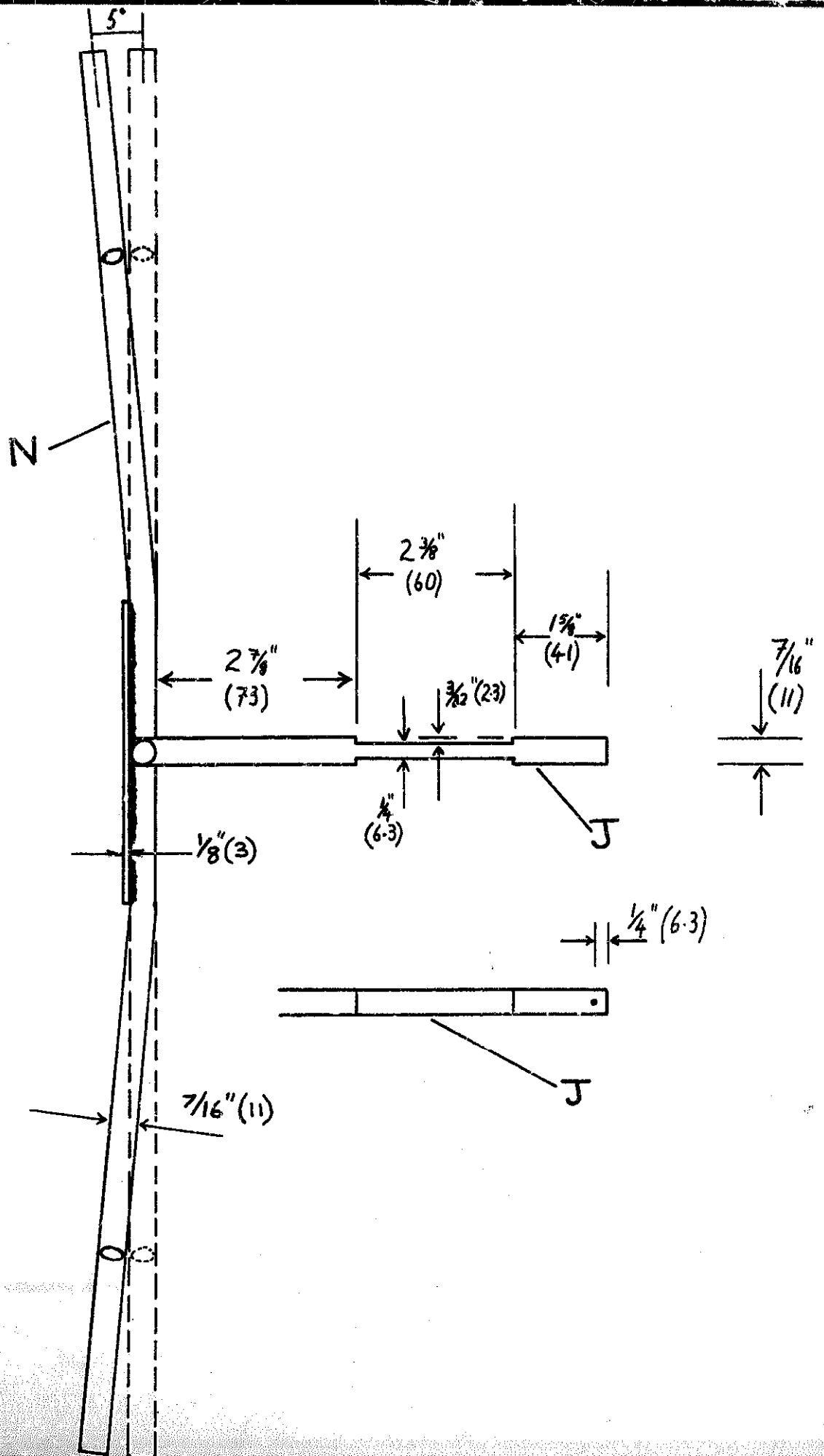

10

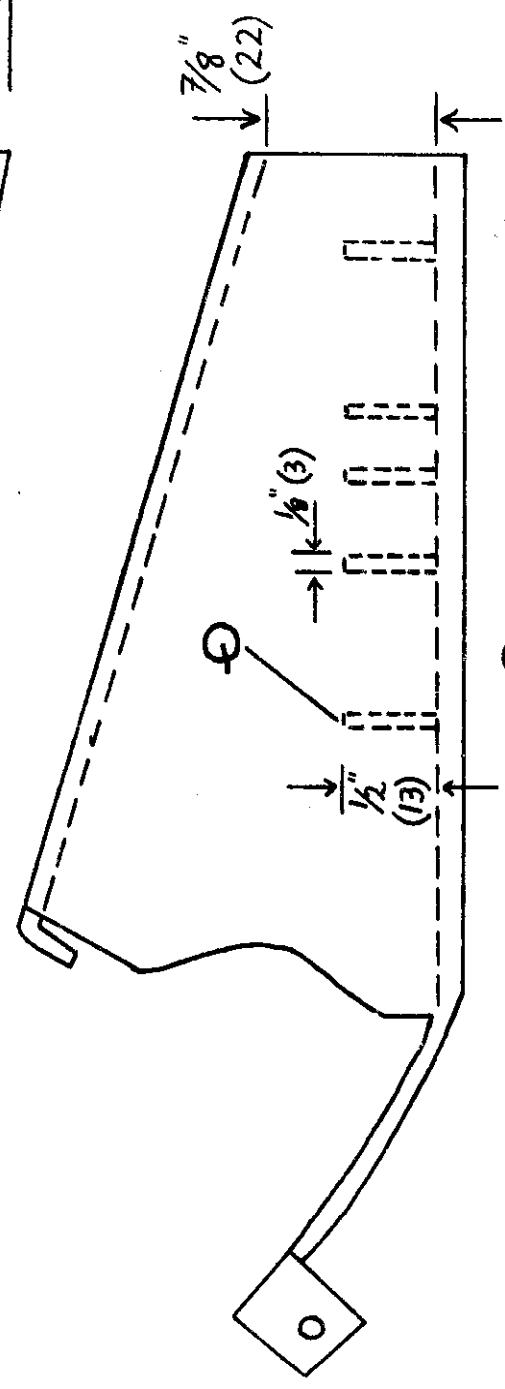
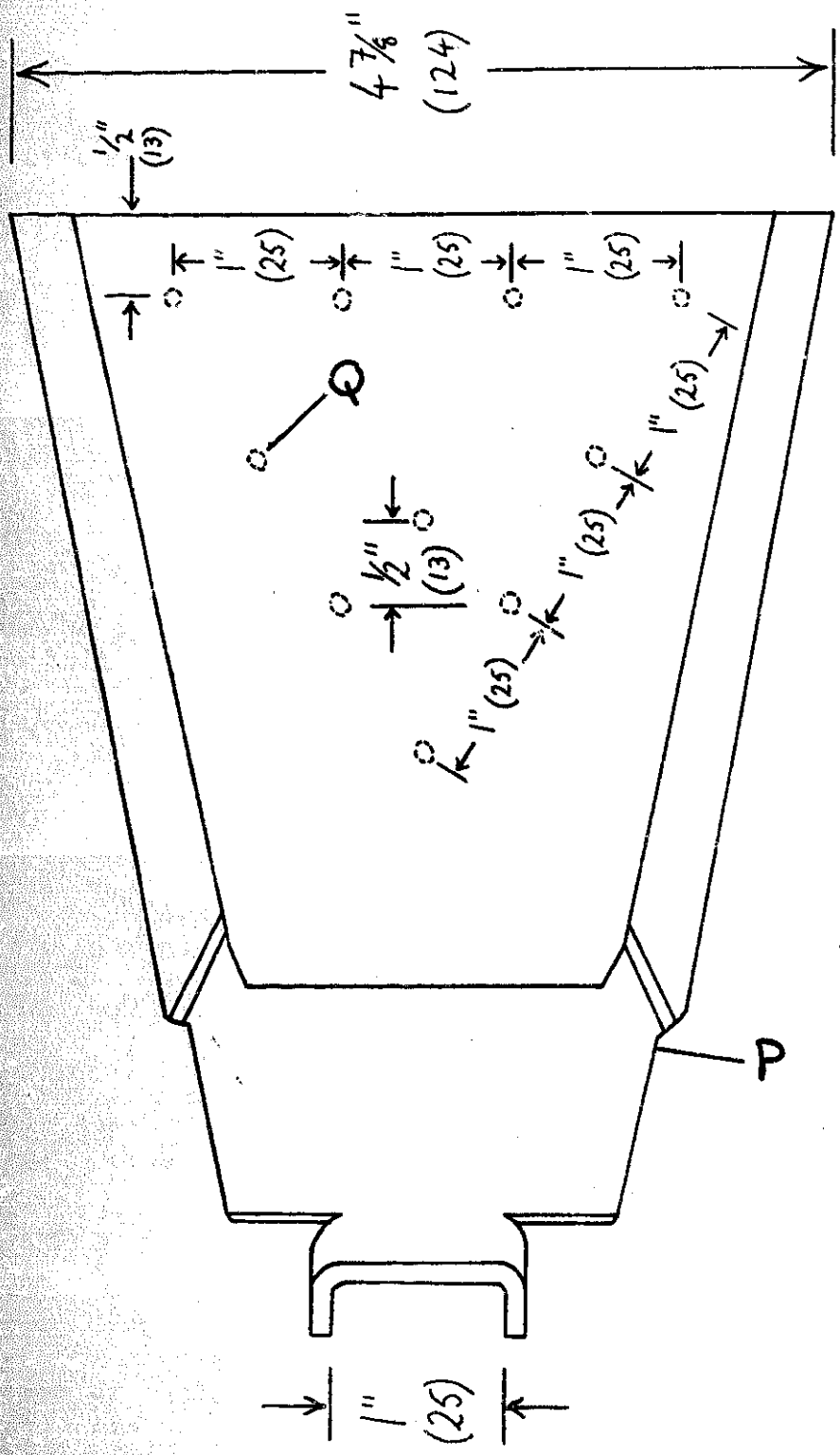

11

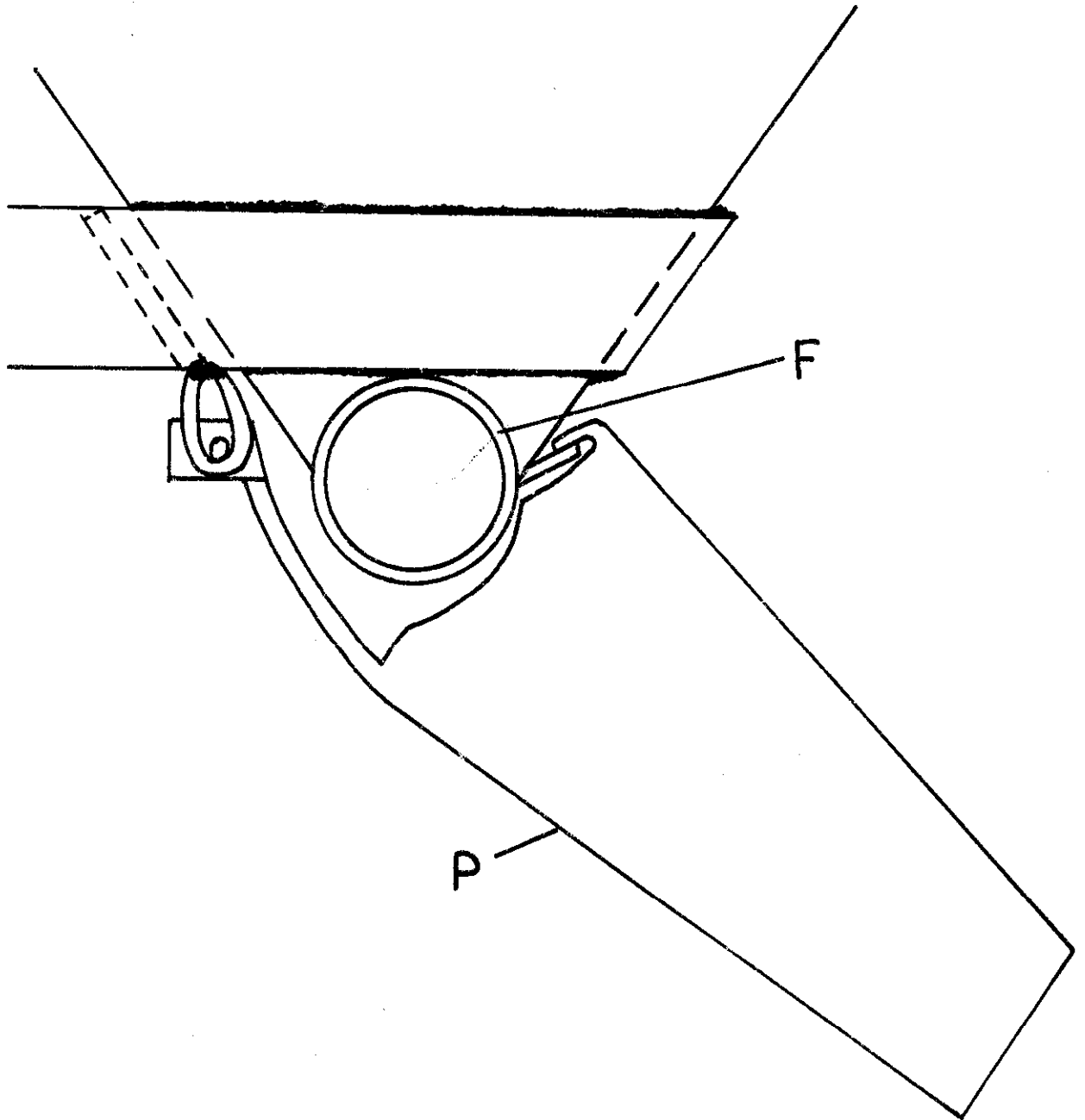



### CALIBRATION OF I.T. GRANULE APPLICATOR USING SUPERPHOSPHATE GRANULES

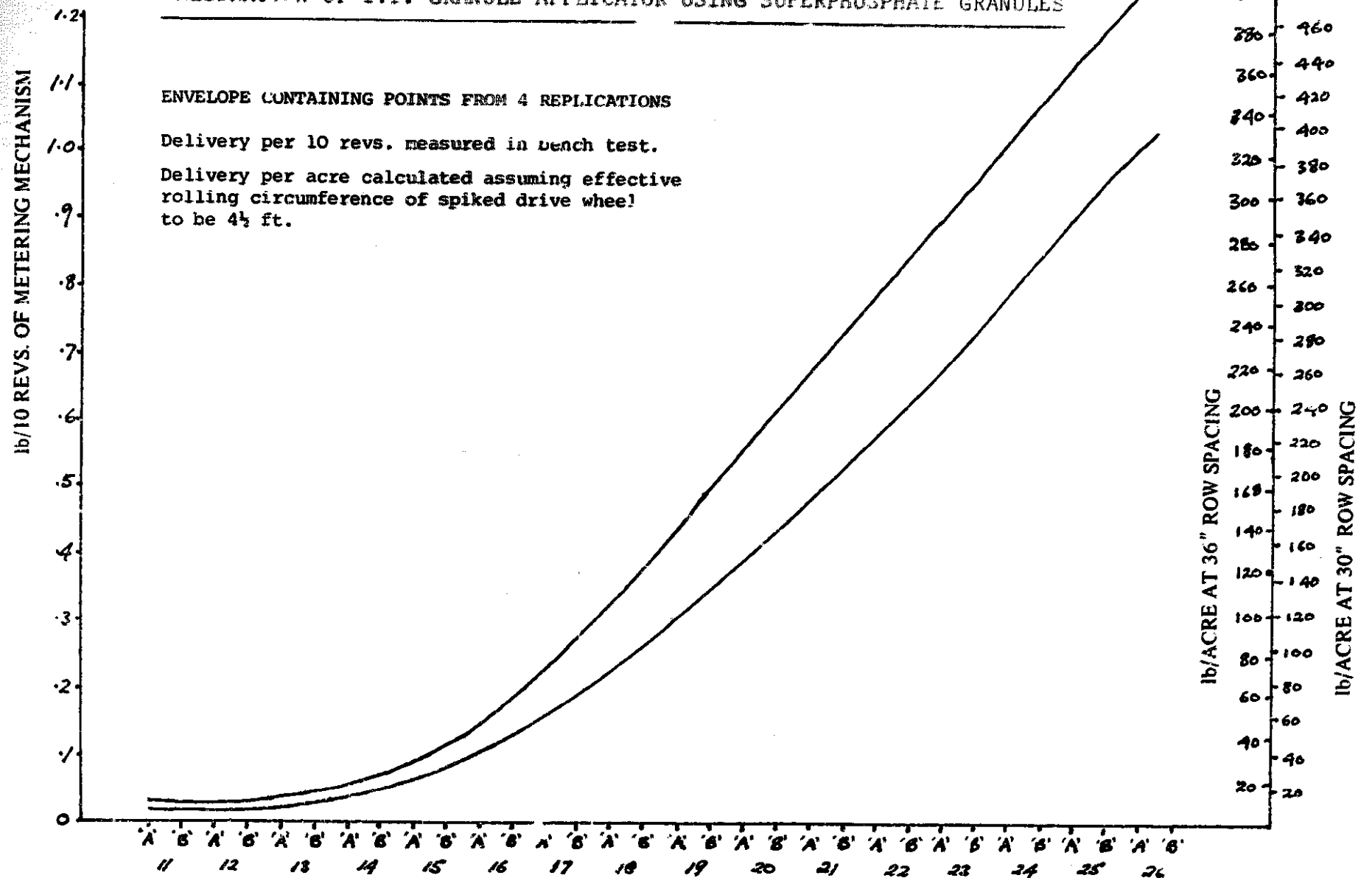

"A" and "B" ARE ALTERNATIVE HOLES IN RATCHET CONTROL LEVER;  
 NUMBERS ARE RATCHET LEVER NOTCHES ( ZERO = FULLY CLOSED POSITION)

3

1

**AT** MICROFICHE  
REFERENCE  
LIBRARY

A project of Volunteers in Asia

IT Expandable Cultivator

ITDG Agricultural Equipment and Tools No. 31

Published by:

Intermediate Technology Publications, Ltd.  
9 King Street  
London WC2E 8HN  
United Kingdom

Paper copies are 0.50 British pounds.

Available from:

Intermediate Technology Publications, Ltd.  
9 King Street  
London WC2E 8HN  
United Kingdom

Reproduced by permission of Intermediate  
Technology Publications, Ltd.

Reproduction of this microfiche document in any  
form is subject to the same restrictions as those  
of the original document.

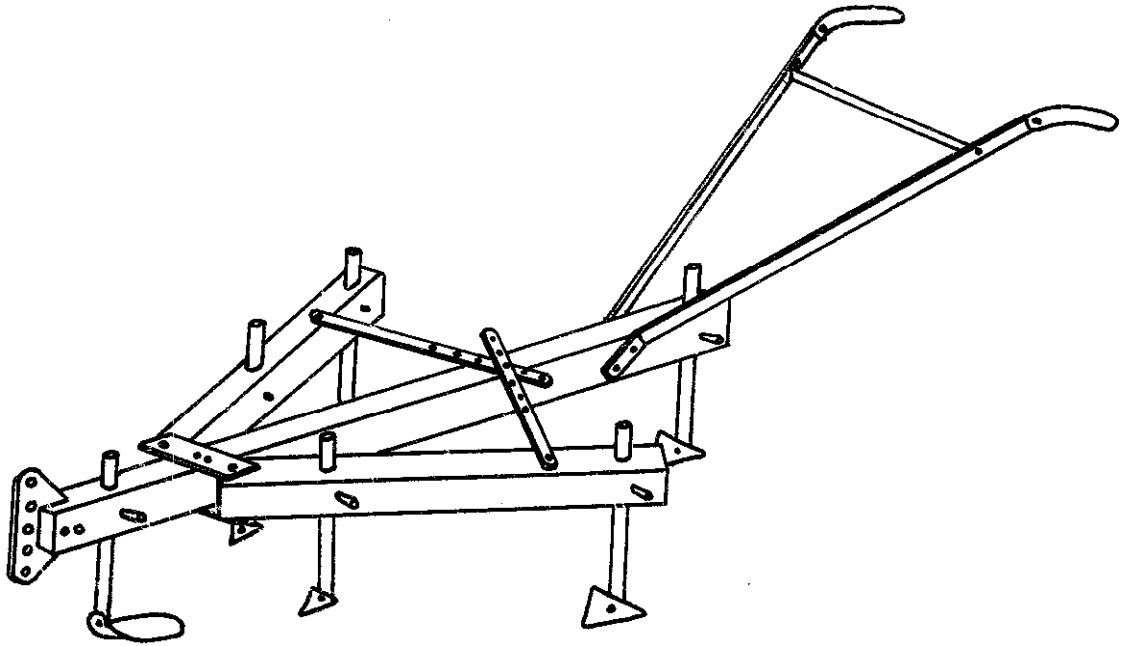

I.T. EXPANDABLE CULTIVATOR  
(DAUDAWA, N.C.S. NIGERIA)

DESIGN: JOHN BOYD

DRAWING: BERNARD WINLO

## I.T. EXPANDABLE CULTIVATOR

Developed by : Intermediate Technology Project, Daudawa, North Central State, Nigeria

### Description :

A lightweight cultivator designed for weeding of crops planted in 70-90 cm spaced rows in sandy soils, to be pulled by one or two oxen or donkeys.

Tines are individually adjustable for depth, making the implement suitable for flat or ridge cultivation. Taper pins engage with notches in the tool standards and are hammered into the wooden beams to lock the tines at the required depth.

The cultivator is suitable for manufacture by village blacksmiths, minimum equipment for manufacture being :

Forge  
Anvil  
Hammer  
Tongs  
Punch  
Chisel

Orthographic drawings use first angle projection. Dimensions are in mm.

<u>ITEM NAME</u>	<u>QTY</u>	<u>MATERIAL PER ITEM</u>	<u>MANUFACTURING NOTES</u>
A Centre beam	1	1200 x 75 x 50 hardwood	Holes for taper pins drilled or burnt 9 $\phi$ and burnt out to form using hot taper pin.
B RHS Beam	1	700 x 75 x 50 hardwood	
C LHS Beam	1	700 x 75 x 50 hardwood	
D Hake plate	1	10 mm M.S. plate	Holes drilled or punched.
E Pivot plate	2	155 x 40 x 10 M.S.	
F Pivot bush	2	75 mm length pipe	O.D. press-fit in 20 $\phi$ holes in B and C. I.D. turns on 15 $\phi$ bolt.
G Adjustor	2	270 x 20 x 6 M.S.	
H Adjustor pin	1	150 x 10 $\phi$ M.S.	
J Handle	2	1000 x 30 x 10 M.S.	
K Handle tie bar	1	500 x 20 x 6 M.S.	
L Handle grip	2	200 x 25 bore water pipe	

(Key continued next page)

<u>ITEM</u>	<u>NAME</u>	<u>QTY</u>	<u>MATERIAL PER ITEM</u>	<u>MANUFACTURING NOTES</u>
M	Skid standard	1	300 x 25 $\phi$ M.S.	Notches made with 6 $\phi$ round file.
N	Skid	1	200 x 40 x 10 M.S.	
P	Tool standard	5	300 x 25 $\phi$ M.S.	
Q	Narrow tine	2	6 mm lorry spring leaf	Fitted to front tool standards.
R	Sweep tine	3	ditto.	Fitted to rear tool standards.
S	Taper pin	6	90 x 12 $\phi$ M.S.	Forged to taper.

Nuts and bolts on which side beams and adjustors pivot should be done up hand tight and the ends of the bolts peened over the nuts.

Rivets may be used instead of bolts.

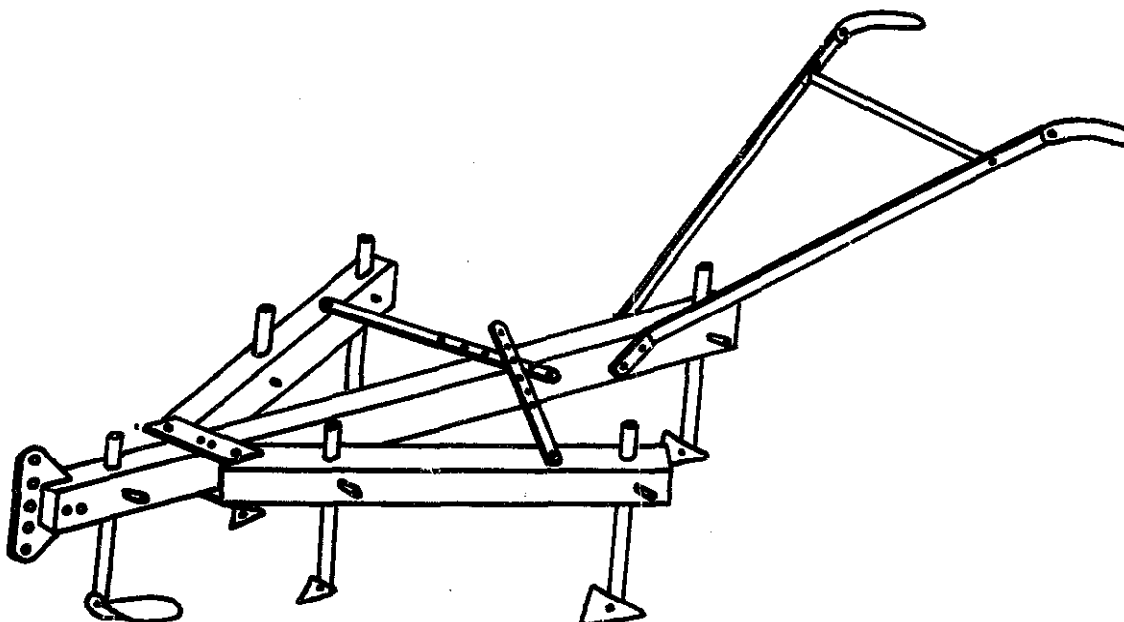

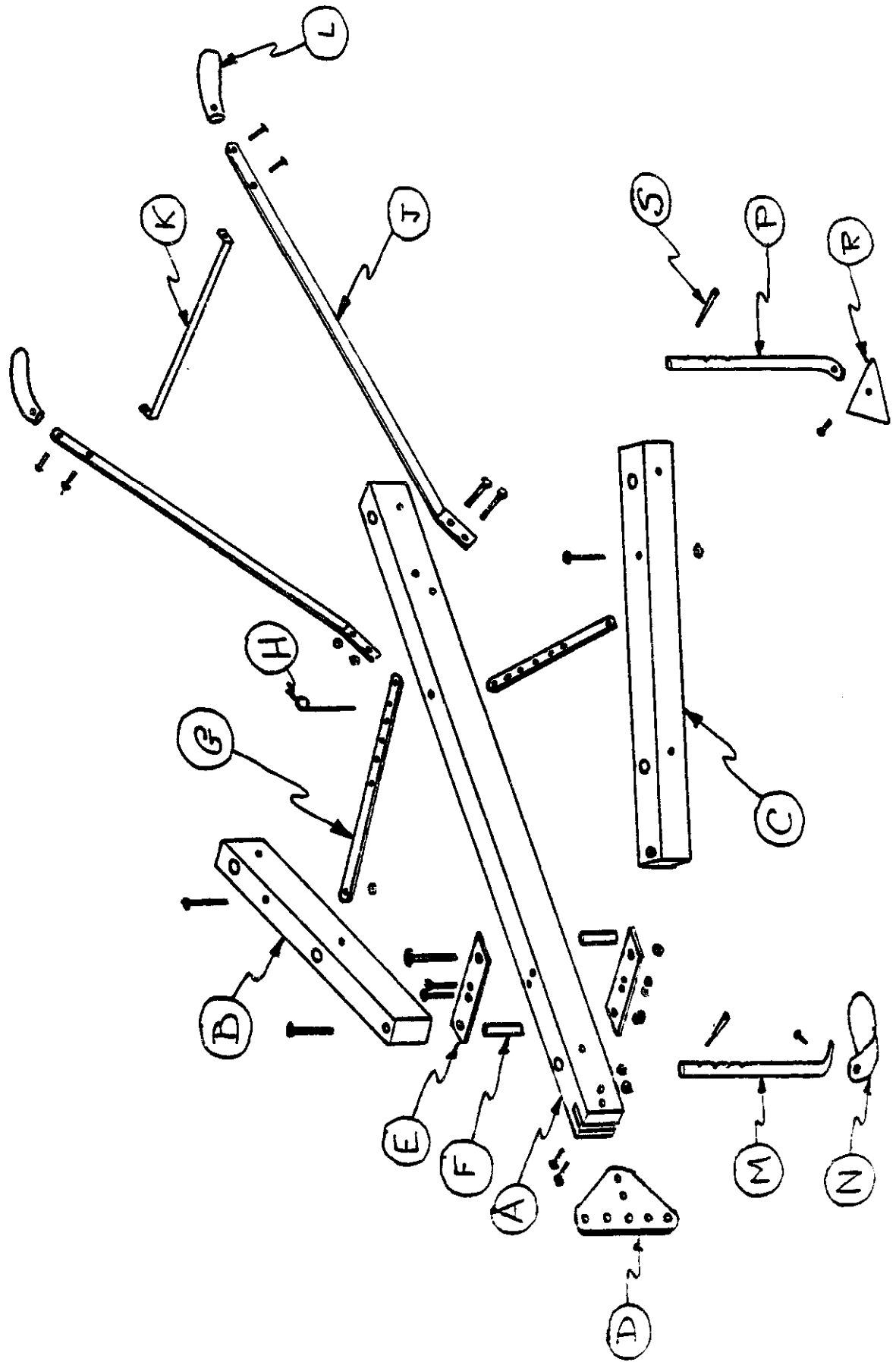

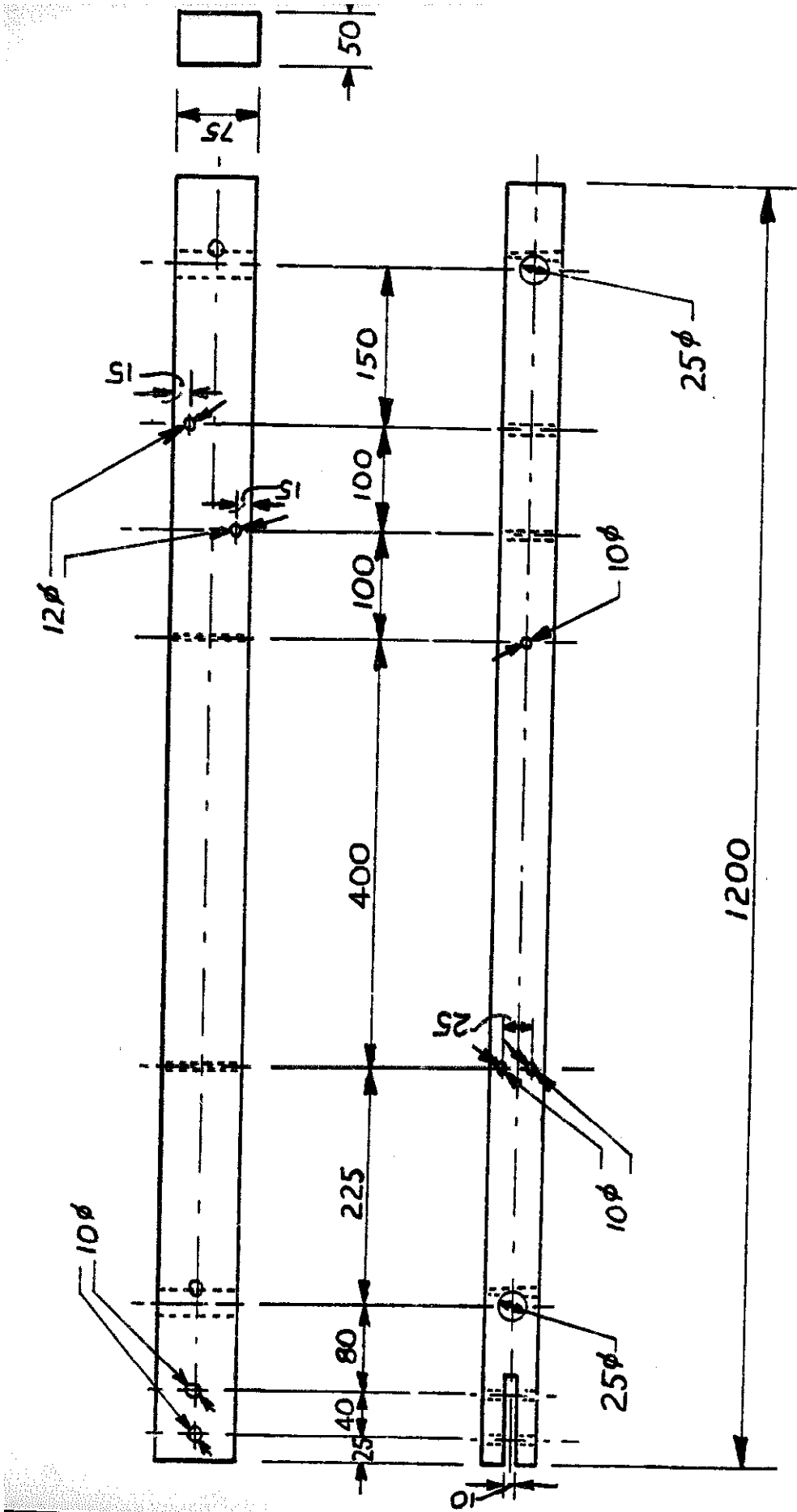

(A)



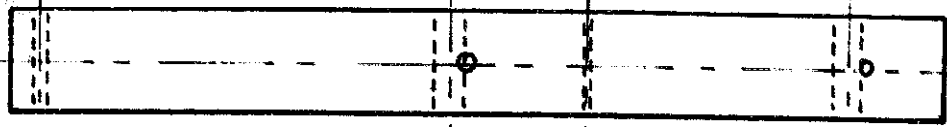

(B)

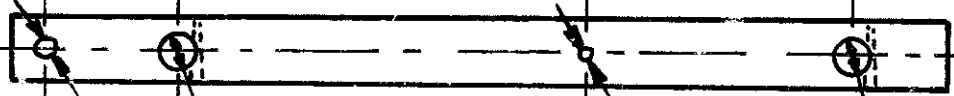
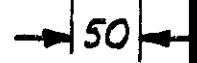

(C)

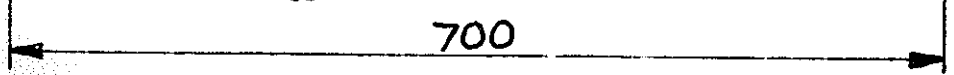

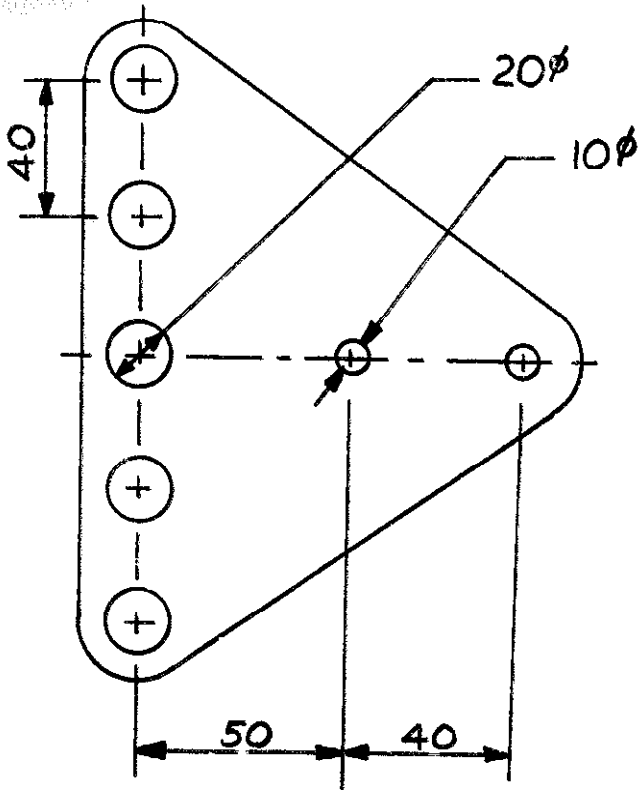

(D)

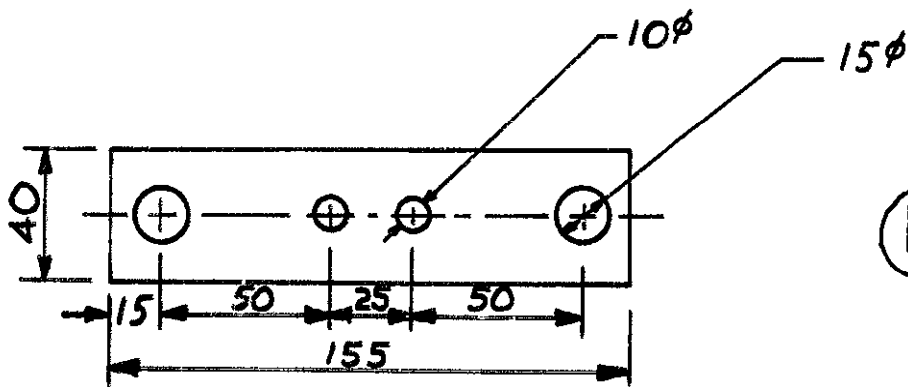

(E)

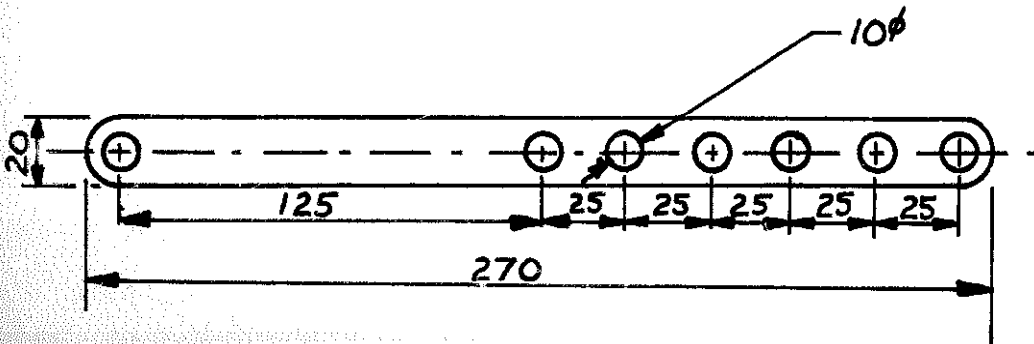

(G)

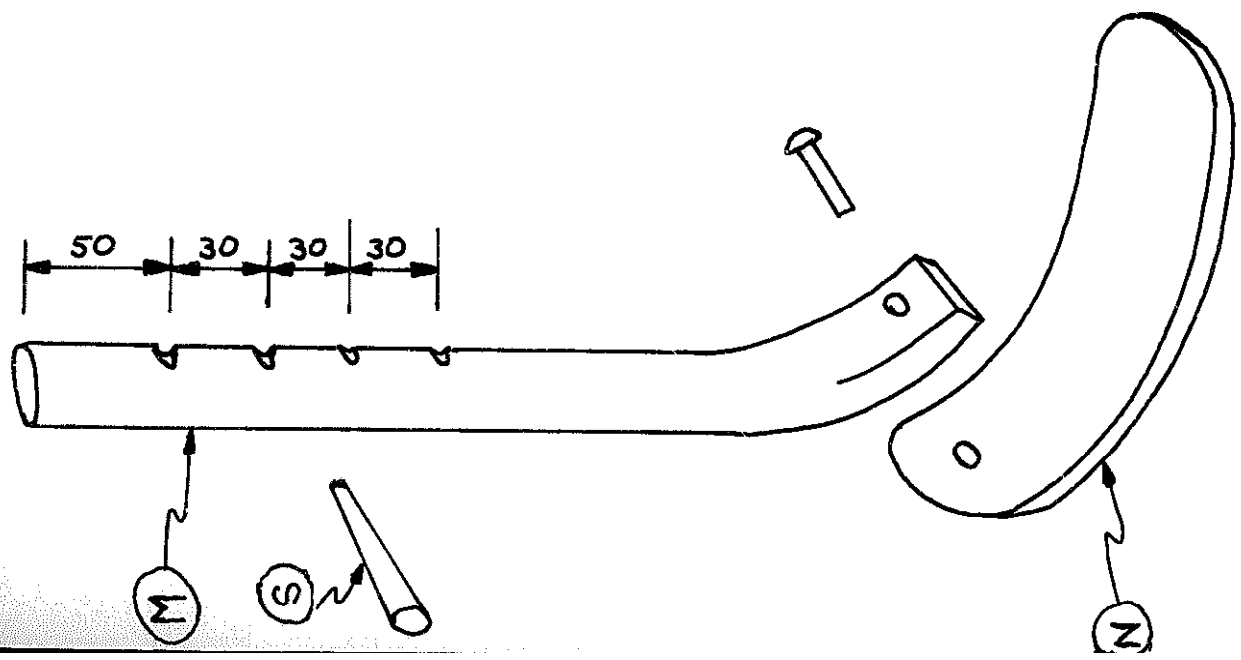
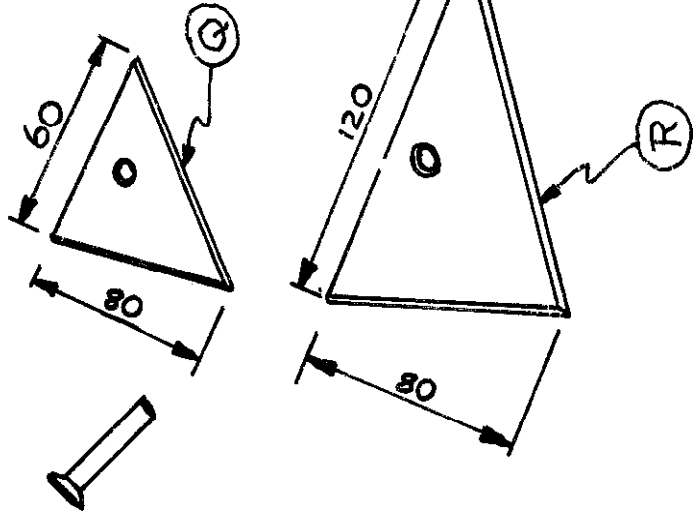
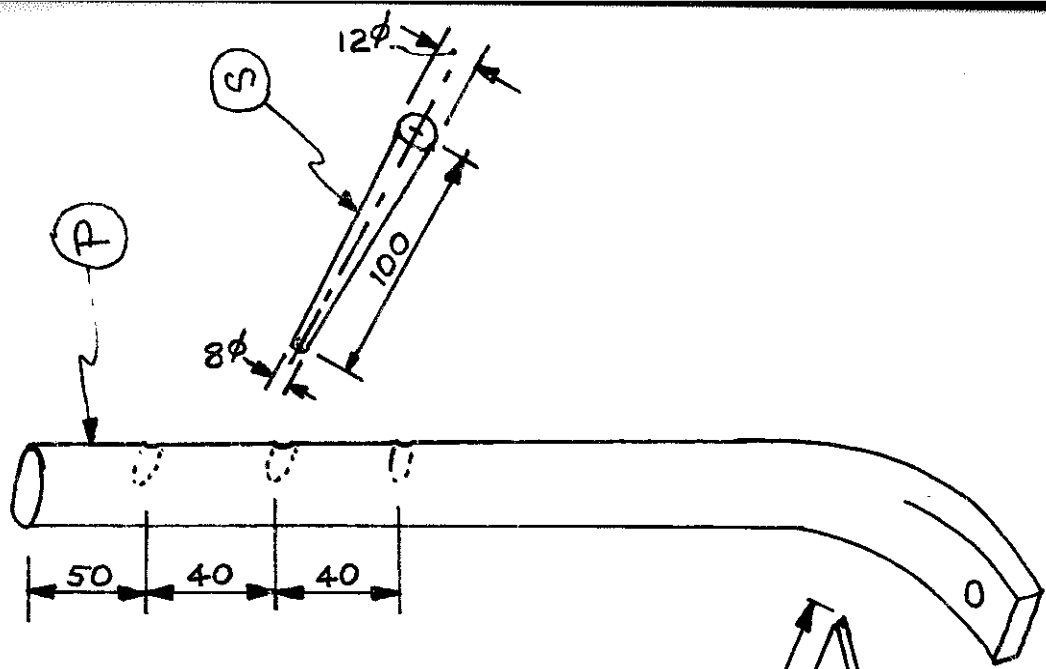

32

**AT** MICROFICHE  
REFERENCE  
LIBRARY

A project of Volunteers in Asia

Seed Dressing Drum (Hand-Operated)

ITDG Agricultural Equipment and Tools No. 32

Published by:

Intermediate Technology Publications, Ltd.  
9 King Street  
London WC2E 8HN  
United Kingdom

Paper copies are 0.50 British pounds.

Available from:

Intermediate Technology Publications, Ltd.  
9 King Street  
London WC2E 8HN  
United Kingdom

Reproduced by permission of Intermediate  
Technology Publications, Ltd.

Reproduction of this microfiche document in any  
form is subject to the same restrictions as those  
of the original document.

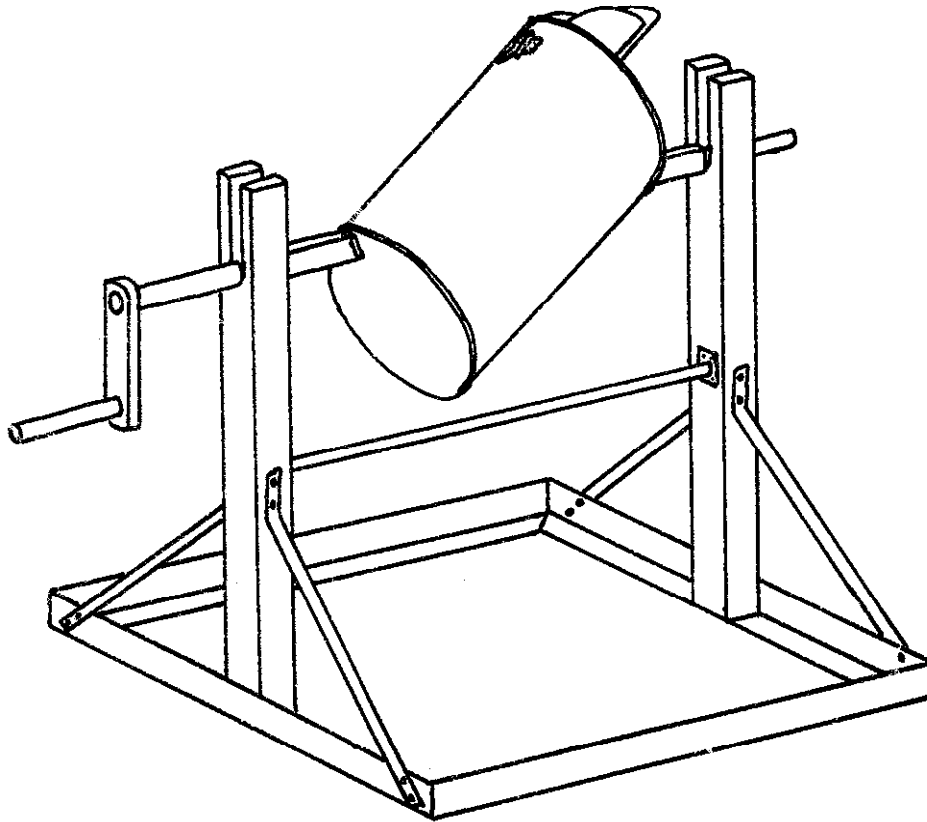

HAND-OPERATED SEED DRESSING DRUM  
(CHITEDZE, MALAWI)

DESIGN: JOHN BOYD

DRAWING: BERNARD WINLO

## HAND-OPERATED SEED DRESSING DRUM

Developed by : G. D. Horspool, Chitedze Agricultural Research Station, Malawi.

### Introduction :

The object was to build a seed dressing device for village use, the design to be of fairly simple construction so that it could be made by local craftsmen.

The test drum used was an ordinary water tin of approximately 13" (330) diameter and 15" (382) in height.

It was found that this drum had a capacity of 30 lb. (13.6 kg) of Chalimbana groundnuts, 35 (15.9 kg) of soya beans or maize, and 38 lb. (17.2 kg) of fertiliser when filled correctly. In a durability test, a total of 1½ tons of fertiliser was mixed without signs of damage. The drum was also used for seed-dressing of groundnuts and maize with satisfactory coverage performance and no apparent adverse effect on germination.

### Description :

With reference to the attached drawings, dimensions are given in inches with millimetre equivalents in brackets.

The handle A is free to revolve on a ¾" (10) diameter bolt which is fitted to the crank arm B. A bolt of ¼" (6) diameter is used to secure the crank arm to the horizontal beam C. The handle, crank and beam are all made of wood, the rectangular part of the beam being 30" (562) in length. The beam ends are supported by timber poles D at a height of 42" (767) from ground level.

Where an open-top container is used, the drum top E should be cut to a diameter of 1" - 1½" (25-38) larger than that of the drum F to allow for bending over (as indicated by the dash line G) and soldering to the sides.

The drum top E, lid H and lid side plates J are made from sheet metal of about 0.5 millimetre thickness.

Cuts are made in the bottom and top of the drum as indicated by Ka, the sheet metal bent up as shown in Kb and tacked to the horizontal beam at Kc.

The outer edge L of the lid is bent down along the line M, and the lid rear pieces N are folded round to form the hinges P. A wooden block Q is nailed inside the lid to provide additional strength, and a sealing strip of foam rubber fitted at R.

The lid side plates are bent outwards along the line S to hold the lid in position when open for filling.

The body of the over-centre latch T is made from 1/16" (2) steel sheet, the latch plate U being riveted or soldered to the drum side. The catch V and lid loop W are of 1/8" (3) diameter steel wire, and the lid loop strap X is made from a piece of rubber tyre inner tube 7" (178) in length.

To ensure that the lid moves freely, it is advisable to fit the lid and hinges before the lid sides and sealing strips are attached.

Apart from the lid aperture, which should not be less than 6" (152) square, the dimensions are flexible depending on the size of drum chosen.

The operating procedure is as follows :

- a) Seed and dressing are poured into the drum as shown in Fig. 1. It is important not to overfill the drum.
- b) The drum is rotated 20 to 40 times as found necessary, Fig. 2.
- c) The position for emptying the drum is given in Fig. 3.

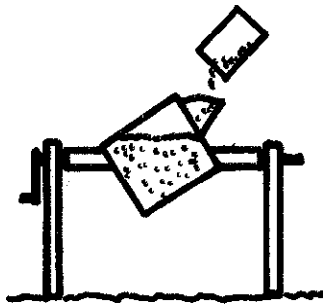

FIG. 1.

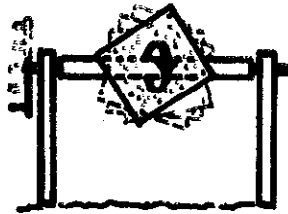

FIG. 2.

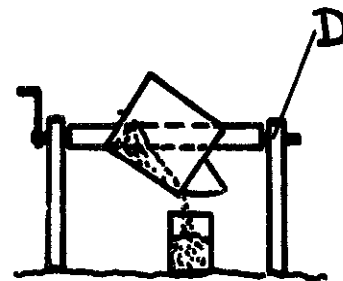
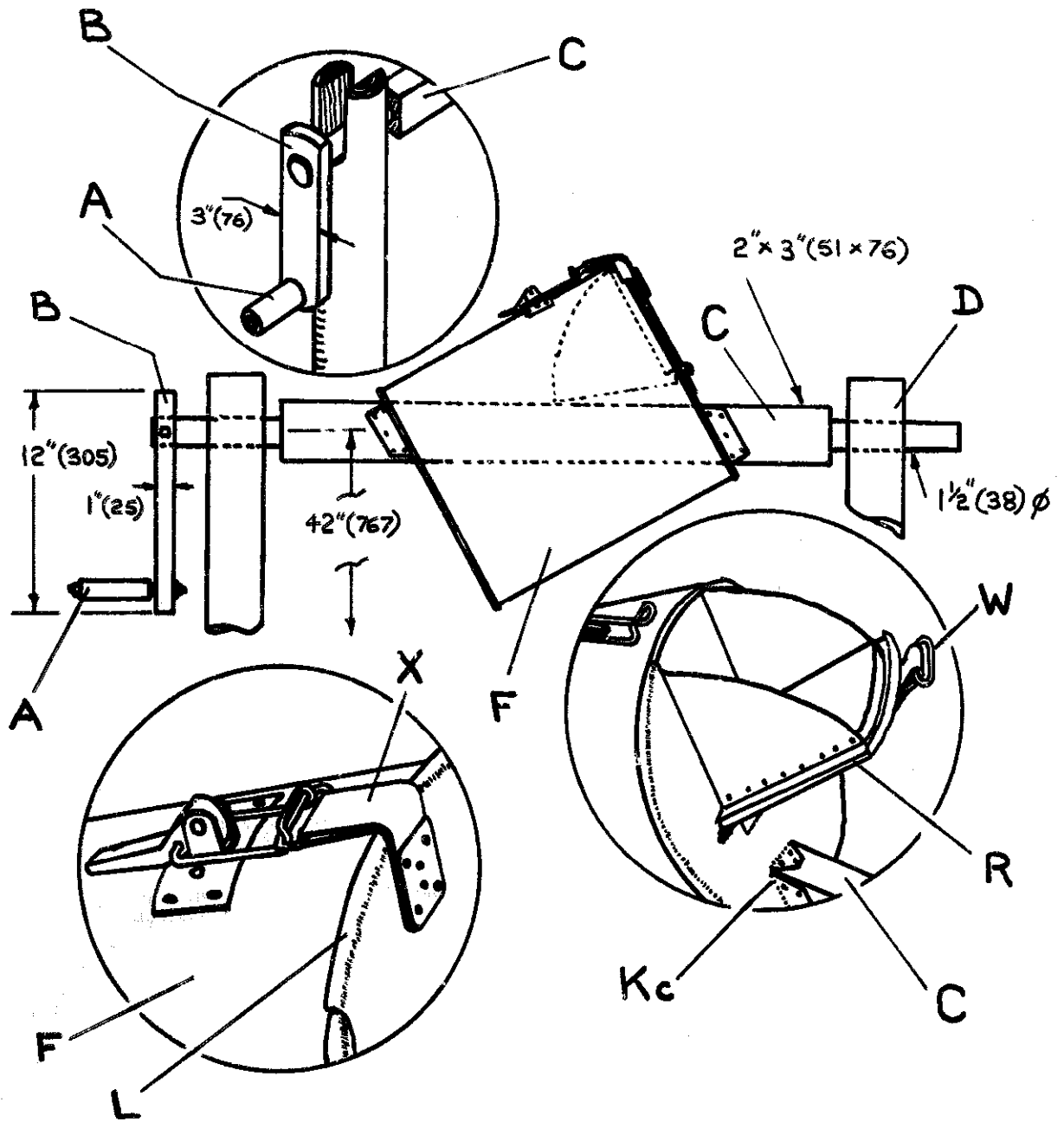
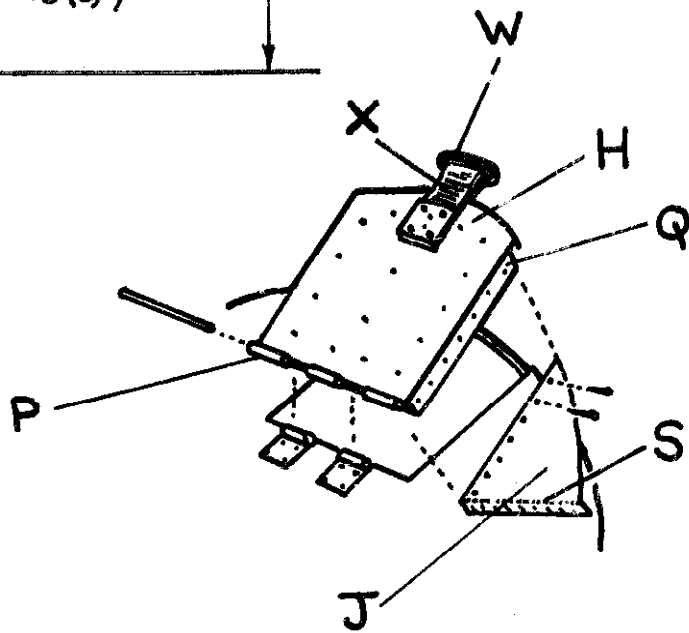
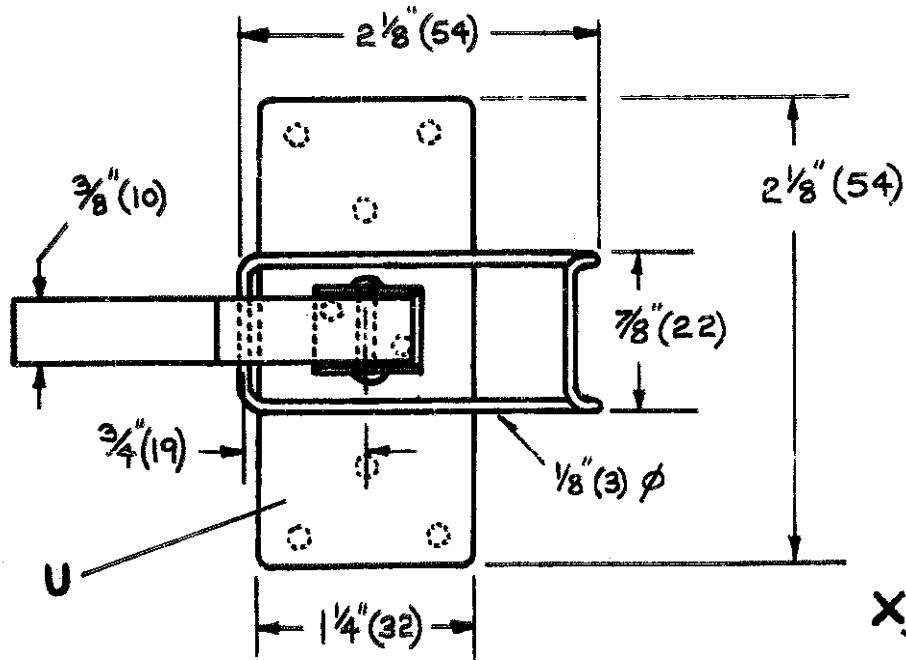
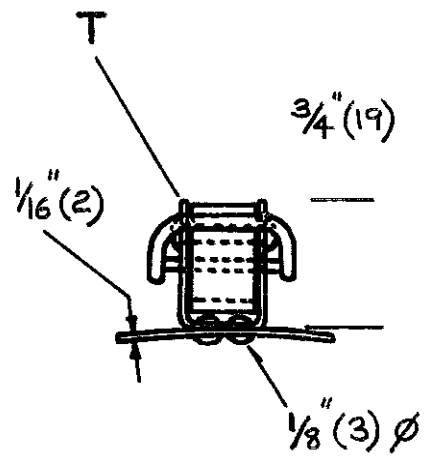
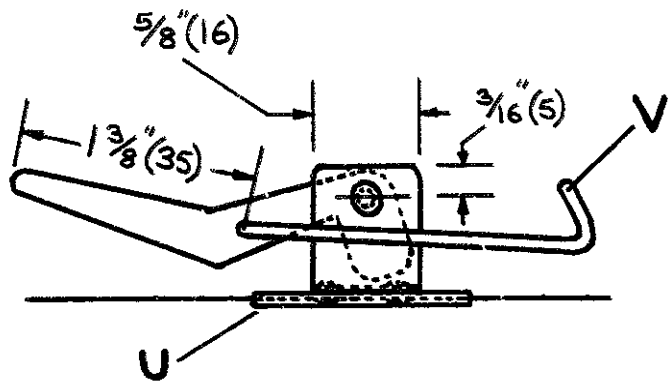
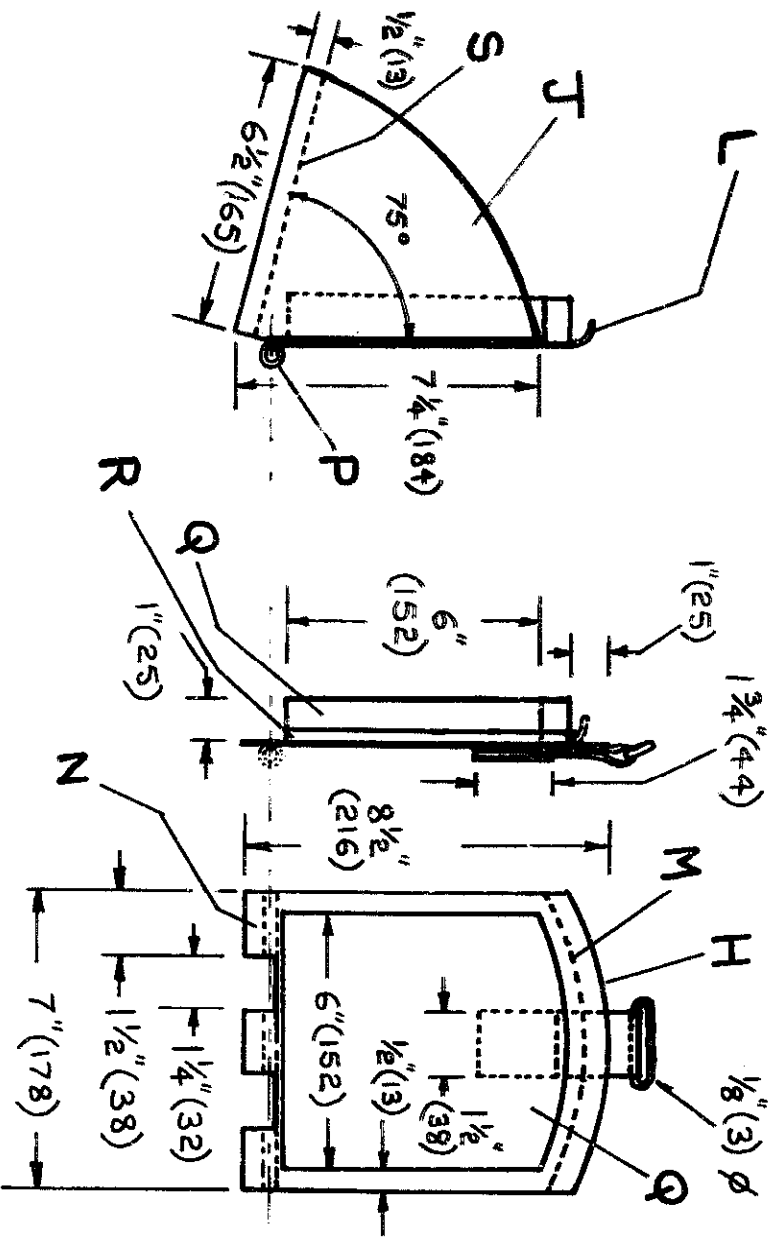
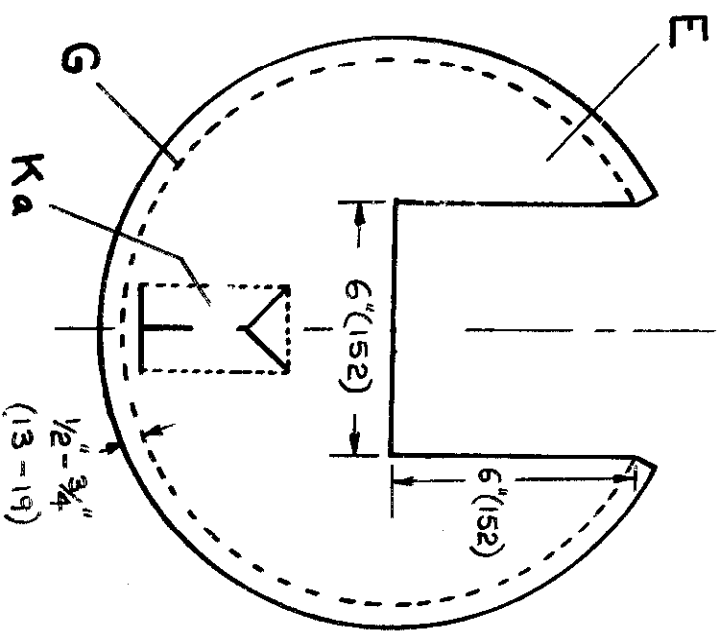
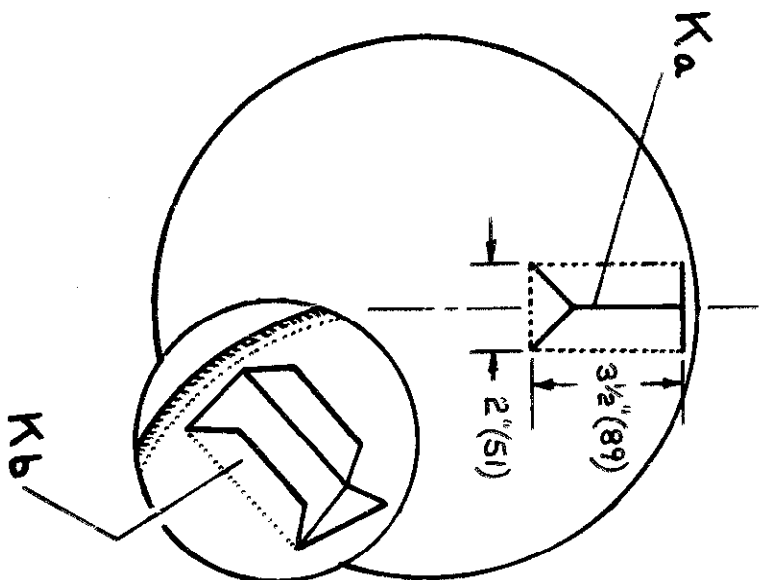

FIG. 3.









33

**AT** MICROFICHE  
REFERENCE  
LIBRARY

A project of Volunteers in Asia

IT High-Clearance Rotary Hoe  
ITDG Agricultural Equipment and Tools No. 33

Published by:  
Intermediate Technology Publications, Ltd.  
9 King Street  
London WC2E 8HN  
United Kingdom

Paper copies are 0.50 British pounds.

Available from:  
Intermediate Technology Publications, Ltd.  
9 King Street  
London WC2E 8HN  
United Kingdom

Reproduced by permission of Intermediate  
Technology Publications, Ltd.

Reproduction of this microfiche document in any  
form is subject to the same restrictions as those  
of the original document.

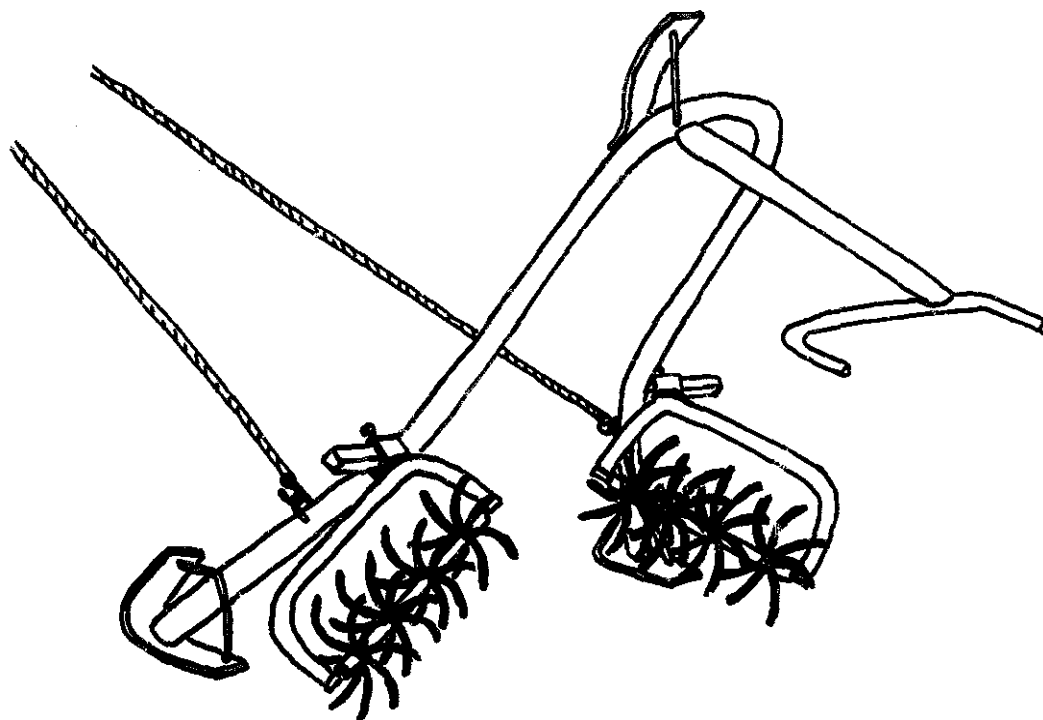

I.T. HIGH-CLEARANCE ROTARY HOE  
(DAUDAWA, N.C.S. NIGERIA)

DESIGN: JOHN BOYD

DRAWING: BERNARD WINLO

### I.T. HIGH-CLEARANCE ROTARY HOE

Developed by : Intermediate Technology Project, Daudawa, North Central State, Nigeria.

#### Description :

This implement is designed for weeding of crops grown on ridges at 75 - 90 cm spacing. It cultivates both sides of one ridge at a time and therefore, unlike cultivators drawn between the ridges, does not require straight and parallel ridges for efficient weeding.

Cultivation is done by two gangs of four spider wheels, each having ten backward curved tines. The gangs are angled to maintain the profile of the ridge and give a slight "earthing up" effect. The width of the uncultivated portion along the crop row can be adjusted from 5 to 20 cm. The rolling action gives light draught and the implement will ride over stumps or other obstructions in improperly cleared land. The rotary hoe can be used for weeding closer to the crop than sweep cultivators without causing apparent crop damage.

An arch frame is used to give 75 cm clearance over the top of the ridge. The frame is pulled by two ropes, one on each side of the crop. The handles are offset to allow the operator to walk in the furrow. Skids for working and transport positions are provided.

Performance is good provided weeding is carried out early, while the weeds are small. The implement is not suitable for use in very hard soil conditions. It can be used in wet soil and has been used successfully for weeding cotton while water was standing in the furrows.

### EXPERIMENTAL ADJUSTABLE ANGLE MODIFICATION FOR I.T. ROTARY HOE

Developed by : Intermediate Technology Project, Daudawa, North Central State, Nigeria.

#### Description :

This modification was designed to allow the I.T. Rotary Hoe to be used on different ridge profiles.

A tube welded onto the U-piece carrying the rotor fits over a round stub Y welded to the clamp and is held in place by a thrust washer and split pin. A plate with a slot is welded to the clamp. A length of angle iron having four holes is welded to the U-piece. Any one of the four holes can be aligned with the slot and a bolt passed through to lock the angle of the U-piece Z.

The adjustable angle version would be a useful research tool for finding the appropriate rotor angle for conditions in any locality. This information could then be used to modify the assembly fixture for the farmers' fixed-angle machines.

Orthographic drawings use first angle projection.

Dimensions given in mm.

ITEM	NAME	QTY	MATERIAL PER ITEM	MANUFACTURING NOTES
A	Arch	1	2400 x 30 bore water pipe	Bend to shape, starting at centre, and saw off ends of pipe level.
B	Stub	2	150 x 30 x 30 M.S.	Square bar or hollow section fabricated from angle iron. Weld to A.
C	Main skid	2	400 x 50 x 10 M.S.	Weld to A.
D	Main skid strut	2	300 x 12 $\phi$ M.S.	Weld to A and C.
E	Handle	1	750 x 25 water pipe	
F	Handle carrier	1	600 x 30 bore water pipe	Prepare ends by partial crushing and weld to E and A.
G	Transport skid	1	350 x 50 x 10 M.S.	Weld to A.
H	Transport skid strut	1	250 x 12 $\phi$ M.S.	Weld to F and G.
J	Hitch loop	2	200 x 12 $\phi$ M.S.	Weld to A.
K	Rotor hub	2	380 x 25 bore water pipe	
L	Tine	80	150 x 12 $\phi$ M.S.	Bend to approx. 100 mm radius.
M	Reinforcing wedges	80	15 x 12 $\phi$ M.S.	Forge to shape and cut off from bar. Weld ten each of L and M into each spider wheel so that spider wheels fit over K. Weld spider wheels to K with tine positions staggered.
N	Axle	2	450 x 15 $\phi$ M.S.	
O	Rotor bearing	4	100 x 30 x 30 hardwood	Wood bearing impregnated with groundnut oil as per IDC Report No. 69-8. O.D. to be press-fit in K, I.D. to be running-fit on N.
P	U-piece	2	745 x 25 bore water pipe	Bend to shape. Partially crush ends for welding to R.
R	Axle supports	4	40 x 15 bore water pipe	Fit R onto N to maintain alignment and weld R to P. Drill 2 $\phi$ hole through R and N for V.
S	Clamp	2	100 x 40 x 5 M.S.	To be sliding-fit on B. Drill 13 $\phi$ hole. Weld 12 mm nut over hole.
T	Clamping bolt	2	40 x 12 eye bolt	
V	Axle retaining pin	2	25 x 2 $\phi$ split pin	
W	Thrust washer	4	2 mm thick washer I.D. 15 mm, O.D. 30 mm	
X	Assembly fixture	1	2050 x 40 x 5 M.S. 760 x 15 bore water pipe	Construct X as shown. Fit (P + R) assemblies onto X using N. Fit S onto B at innermost position. Bring P and S together as shown and weld P to S.



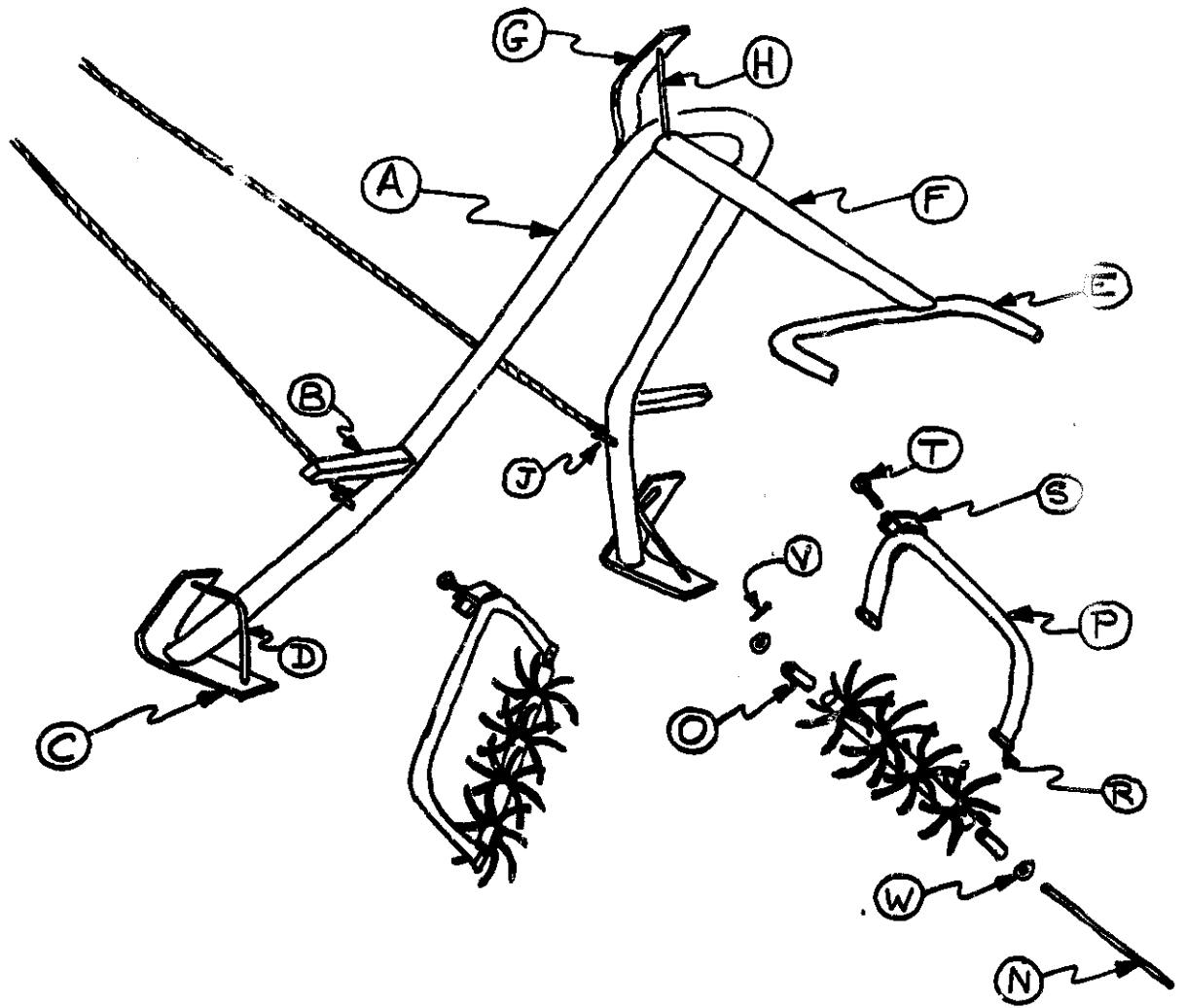

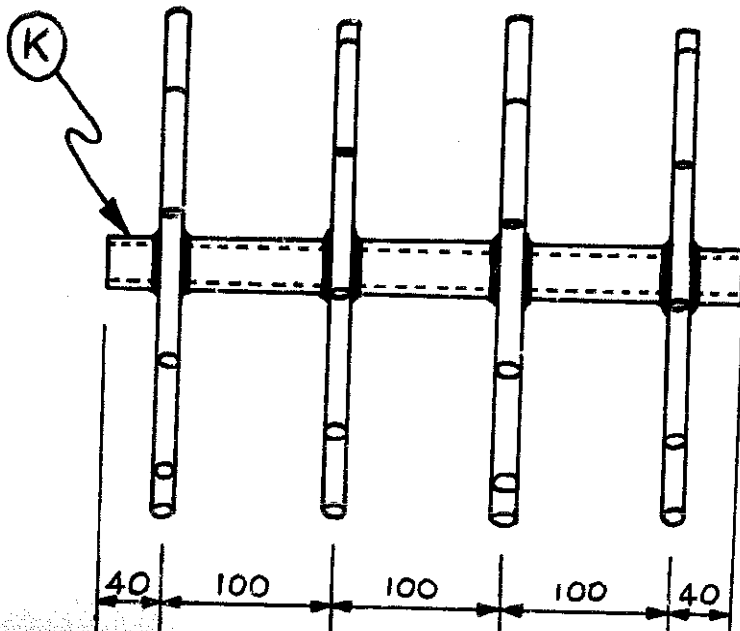
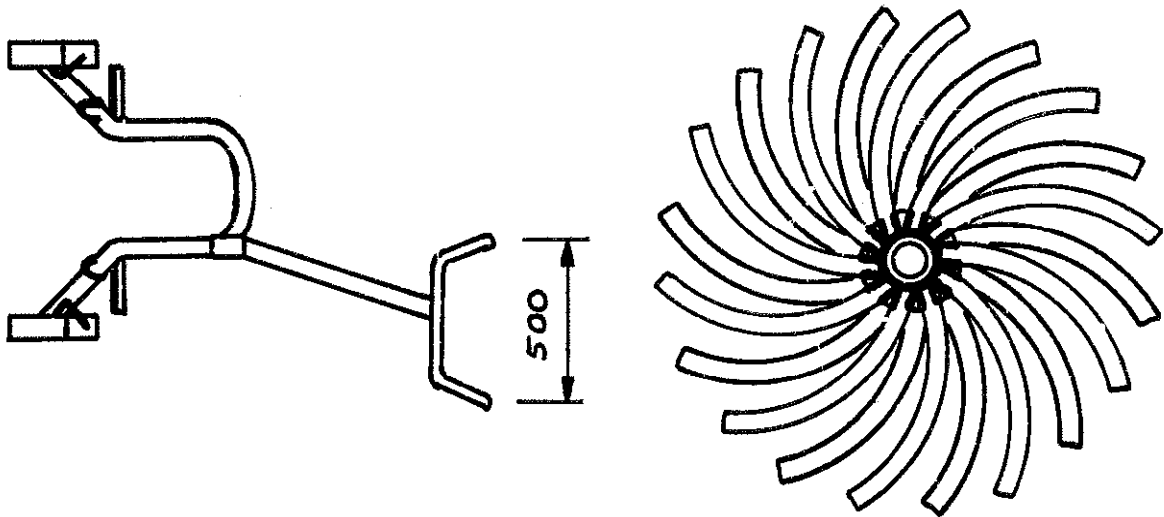
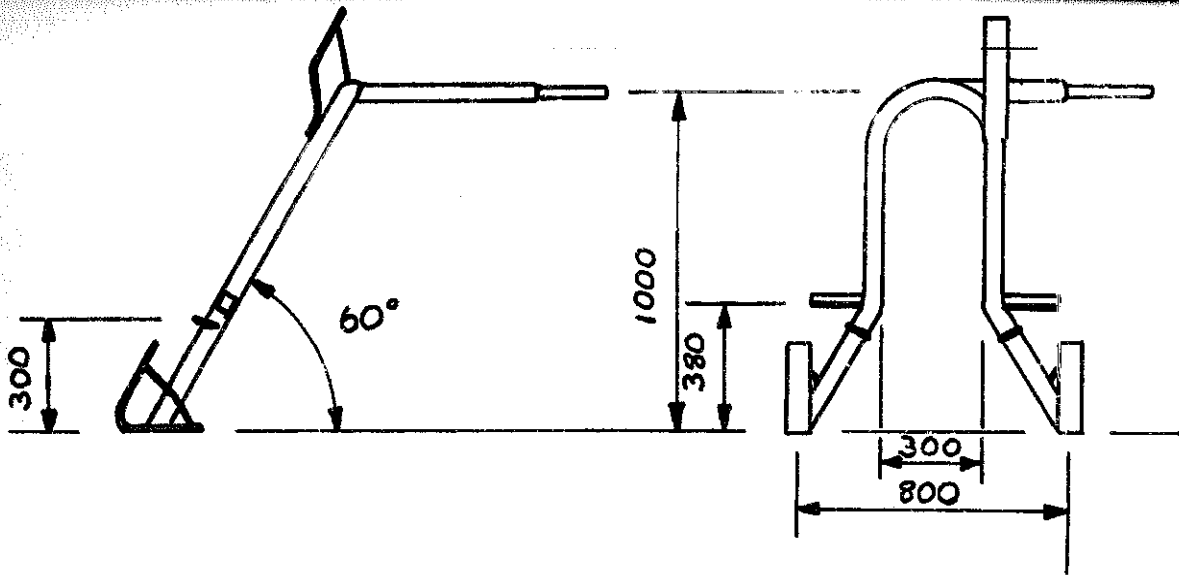

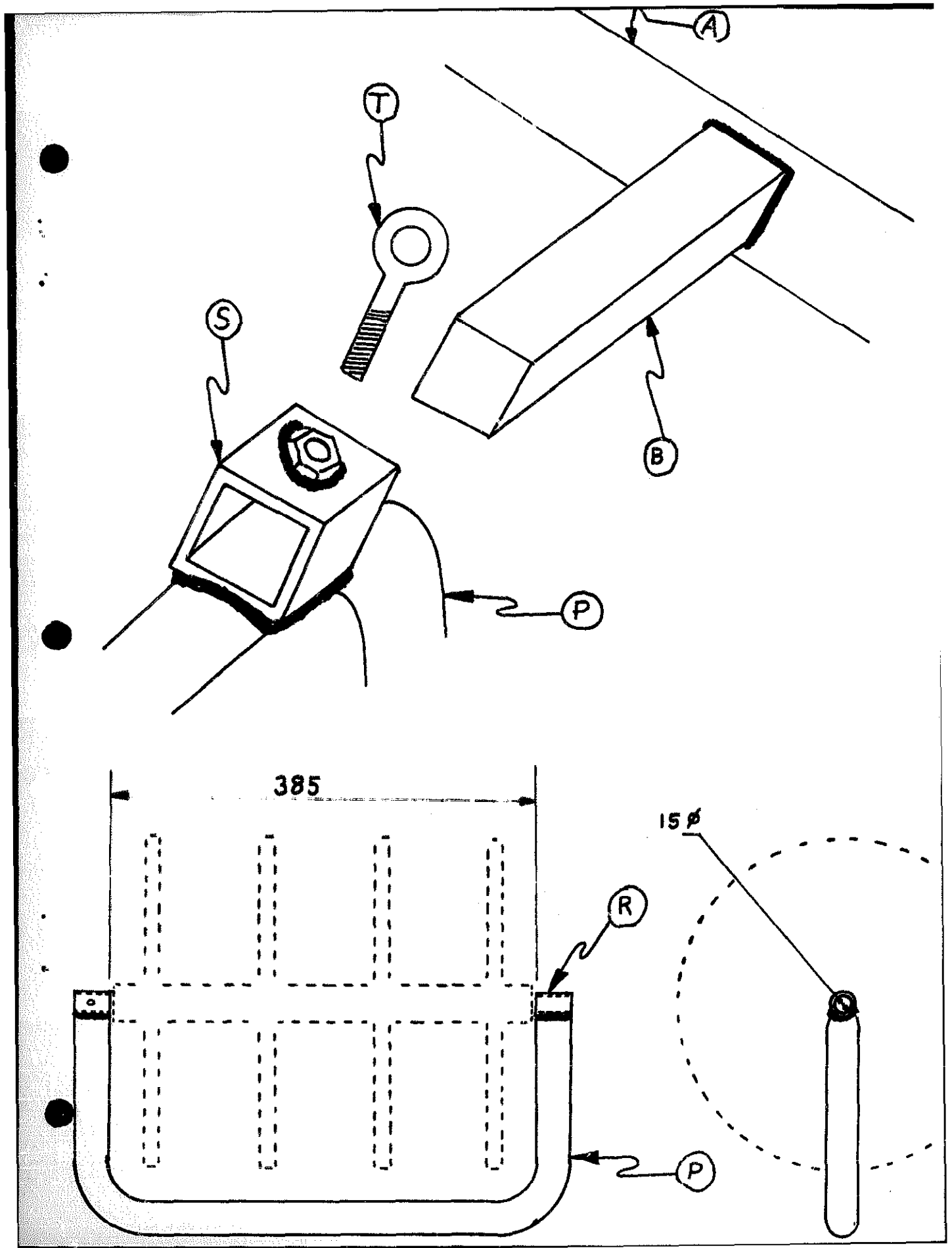

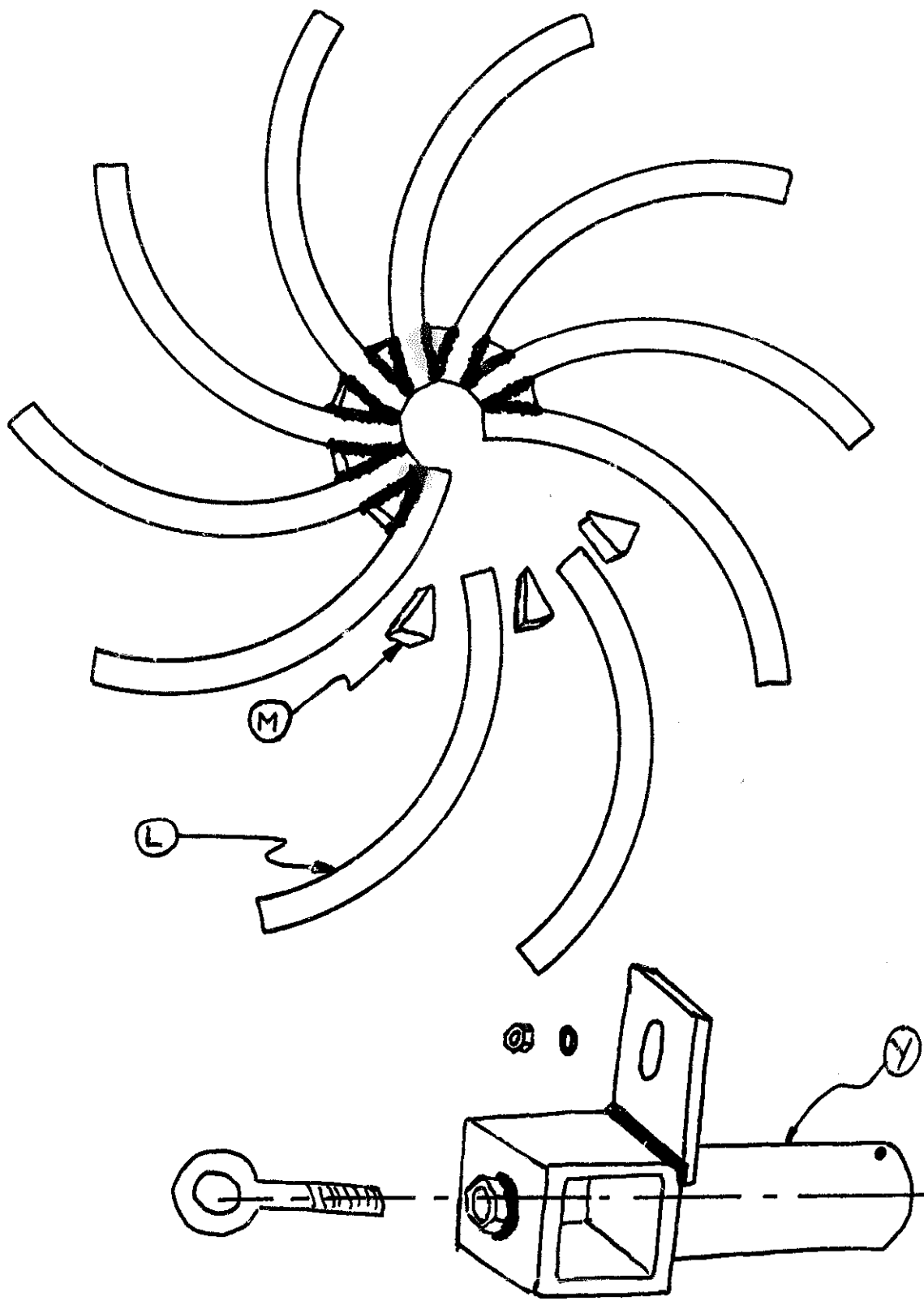

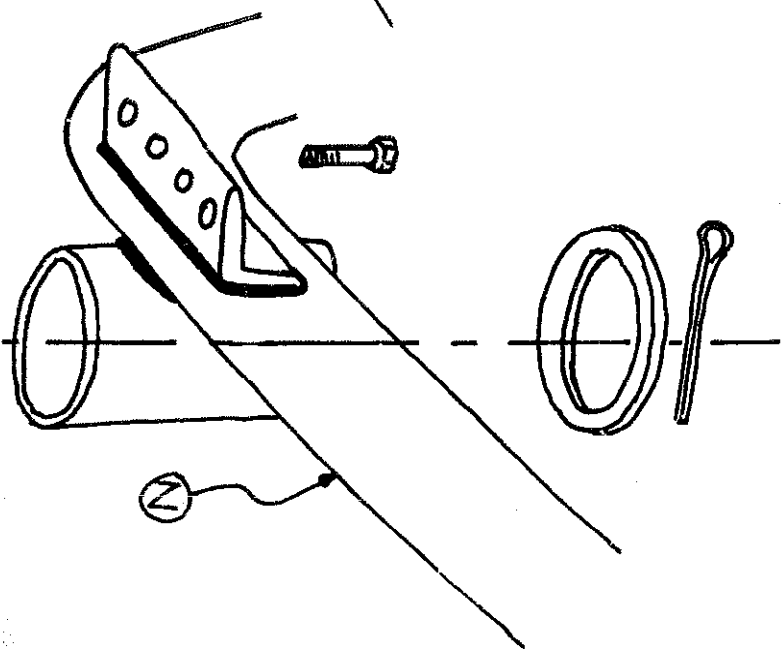
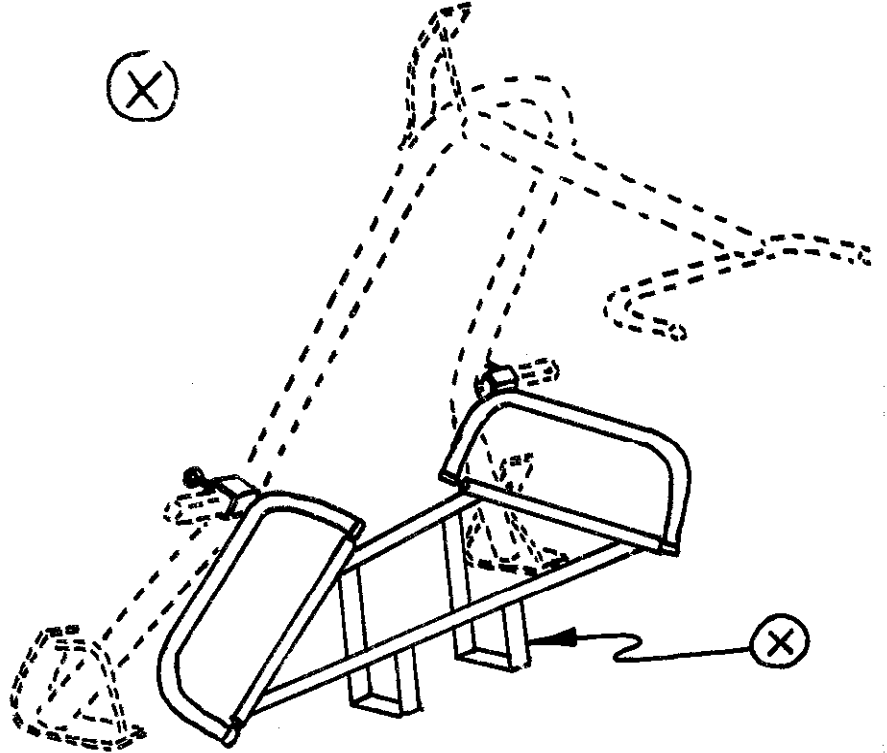
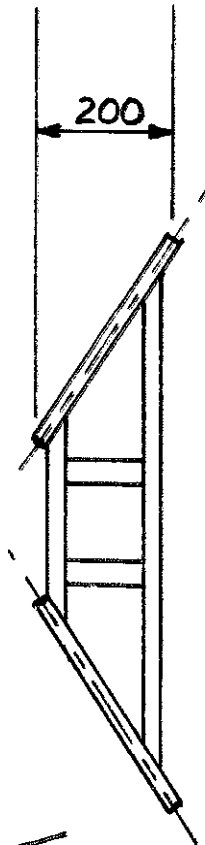
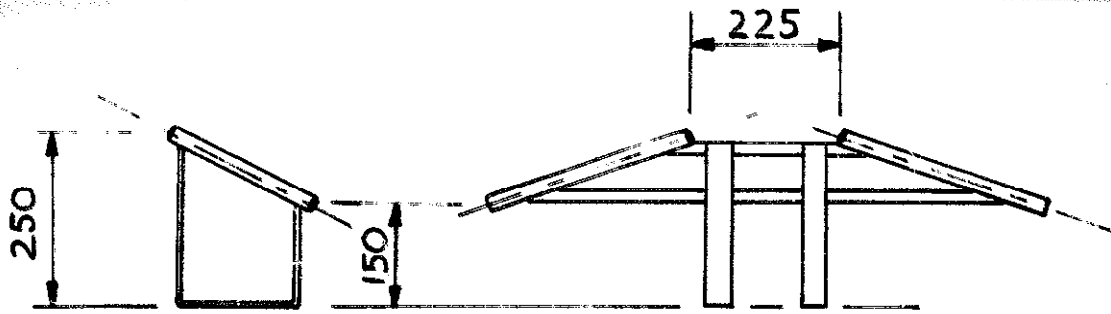

36

**AT** MICROFICHE  
REFERENCE  
LIBRARY

A project of Volunteers in Asia

The Weeder Mulcher

ITDG Agricultural Equipment and Tools No. 36

Published by:

Intermediate Technology Publications, Ltd.  
9 King Street  
London WC2E 8HN  
United Kingdom

Paper copies are 0.50 British pounds.

Available from:

Intermediate Technology Publications, Ltd.  
9 King Street  
London WC2E 8HN  
United Kingdom

Reproduced by permission of Intermediate  
Technology Publications, Ltd.

Reproduction of this microfiche document in any  
form is subject to the same restrictions as those  
of the original document.

AGRICULTURAL EQUIPMENT AND TOOLS FOR FARMERS DESIGNED FOR LOCAL CONSTRUCTION

No. 36

# THE WEEDER MULCHER

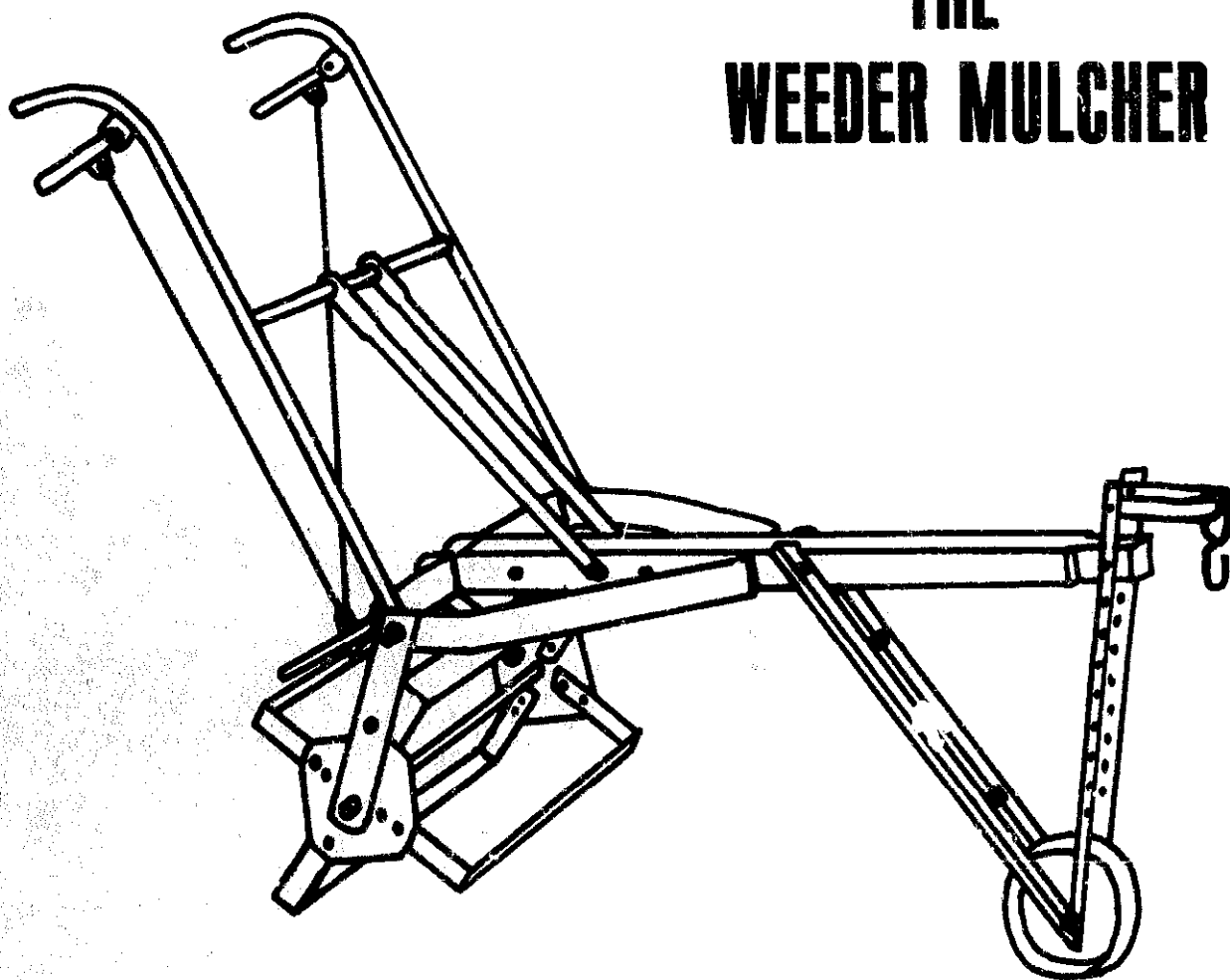

**Intermediate  
Technology** Publications Ltd  
9 King Street, London WC2E 8HN, England  
Telephone 01-836 6379



## THE I.I.S.R. WEEDER-MULCHER

### Acknowledgment:

Developed by R.R.Panje and R.G.Menon of the Indian Institute of Sugarcane Research, Lucknow.

Copied from the original plans by R.D.Mann and B.P.Winlo

### Description:

This animal-drawn self-cleaning weeder was originally developed for use in sugarcane plantations. It is designed to destroy weeds, leave a mulch on the soil surface to conserve moisture and give a high work output per day (up to 5 or 6 acres of row crop work per 8 hour day). It can be used on most row crops with a spacing of 30 inches (75cm) or more.

### Operation:

The blade works at a depth of 2 inches (5cm) below the surface. The weed roots are cut or pulled out and the soil layer is lifted slightly, which helps to break any crust present. If the blade clogs it will rise out of work. When this happens the operator flicks the release levers, the rotor moves round 90° and is locked in place by the lever. The weeds drop off the blade and soon dry out. Best results are obtained on tilled soils which have settled down to form a crust.

The implement is light enough to be carried on the yoke of a pair of bullocks yet robust enough to withstand a fair amount of rough handling. The blades can easily be replaced by a village blacksmith and the whole machine can be built in any reasonably well-equipped workshop.

The machine can be used in two forms:

- (1) with a long draught pole and two depth wheels at the rear (as shown in the detailed drawings).
- (2) with a short beam and draught chain and a single depth wheel at the front of the beam (as shown on the cover).

ITDG has not yet had the opportunity to field test this implement. The information above was supplied by the Indian Institute of Sugarcane Research.

It has been suggested that the implement might be improved by splaying out the handle brackets to improve lateral rigidity and that the axle support brackets might need to be strengthened for use in hard soils.

List of materials required for the fabrication of the I.I.S.R. Weeder Mulcher.

Part No.	Description	Specification	Material	Number required.
1	Blade	600mm x 38mm x 6mm	M.S.Flat	4
2	Cutter Assembly Plate	165mm x 165mm x 3mm	M.S.Plate	2
3	Axle	774mm length x 19mm Dia.	M.S.Rod	1
4	Latch	345mm x 19mm Dia. Pipe	M.S.Pipe	1
5	Brackets	330mm x 50mm x 6mm	M.S.Flat	2
6	Frame	1.225m x 50mm x 6mm	M.S.Flat	2
7	Handle	860mm x 19mm Dia. Pipe	M.S.Pipe	2
7a	Handle cross bar	445mm x 19mm Dia. Pipe	M.S.Pipe	1
8	Latch grip	140mm x 19mm Dia. Pipe	M.S.Pipe	2
9	Handle bracket	500mm x 37.5mm x 6mm	M.S.Flat	2
10	Latch rod	1.425m x 6mm Dia.	M.S.Rod	1
11	Wooden beam	2.80m x 75mm x 50mm	Sal wood	1
12	Transport wheel bracket	380mm x 50mm x 60mm	M.S.Flat	2
13	Transport wheel	125mm x 38mm width	C.I.	2

NOT TO SCALE  
ALL DIMENSIONS : mm

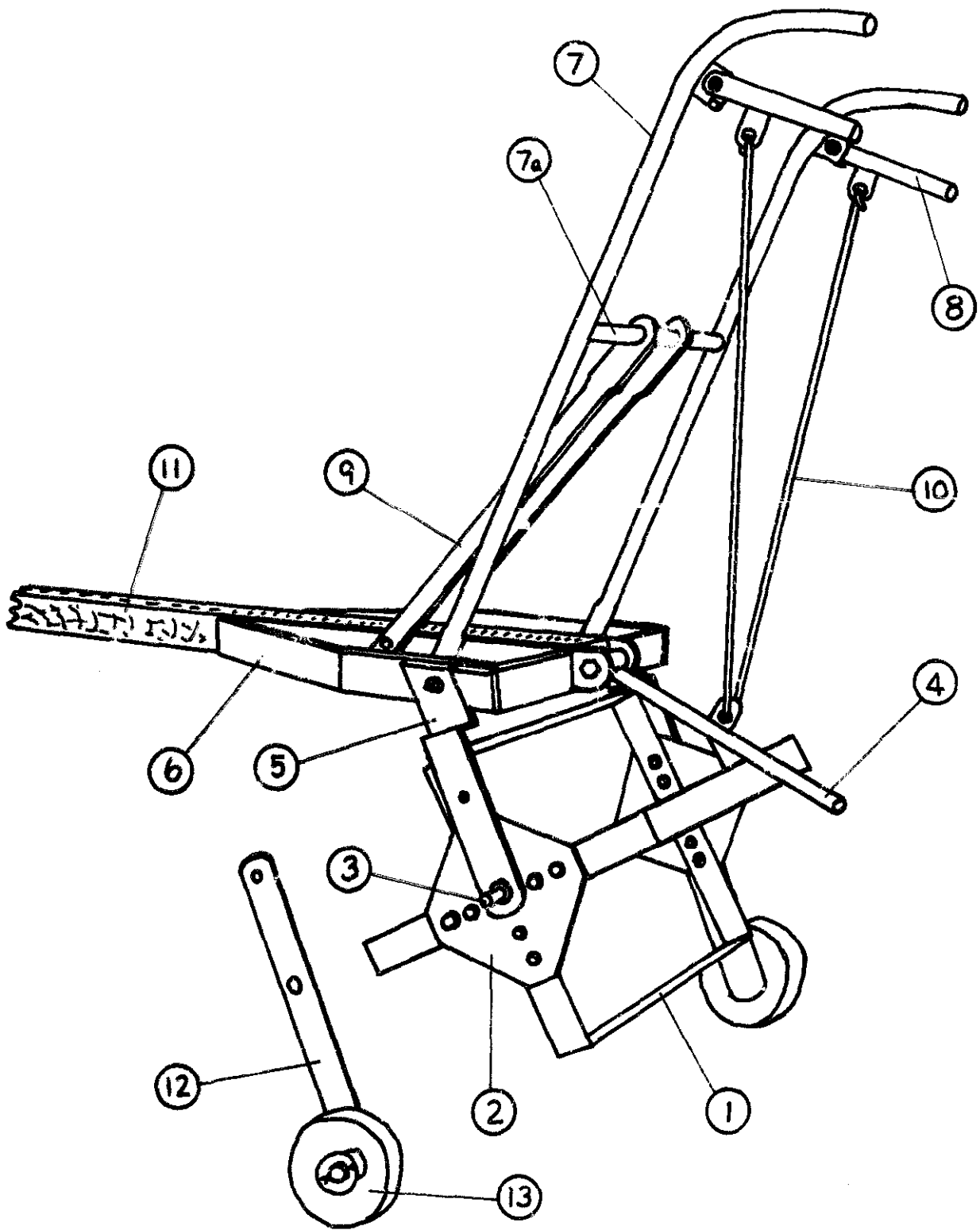

PART No. 4

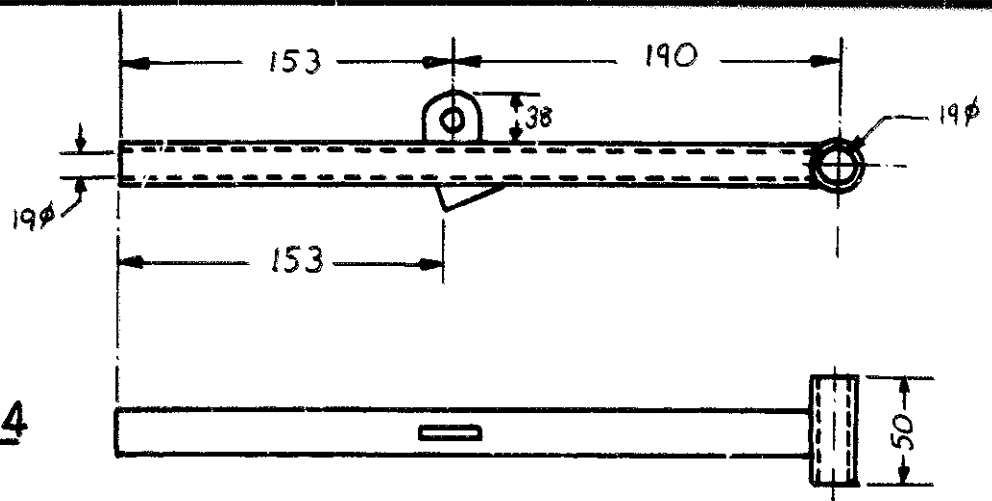

PART No. 5

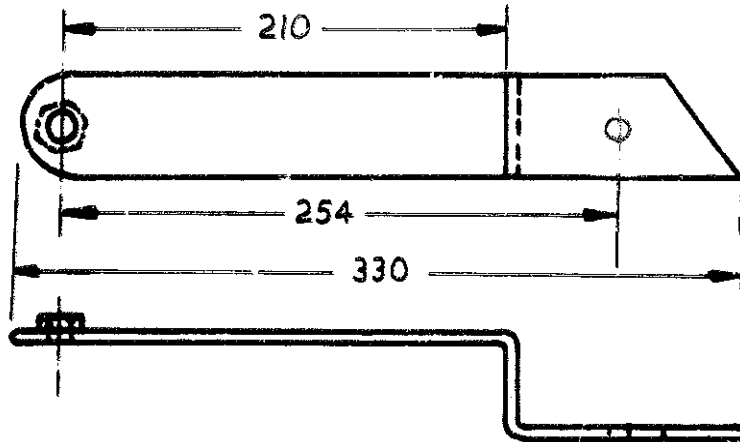

LEFT

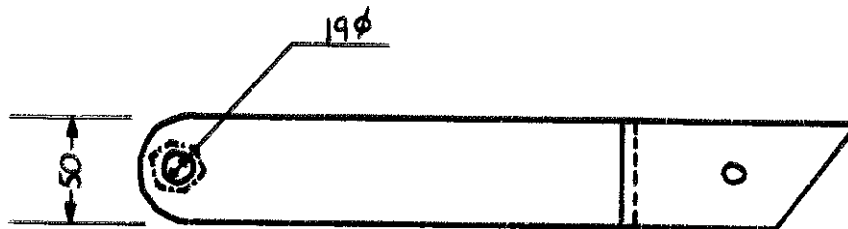

RIGHT

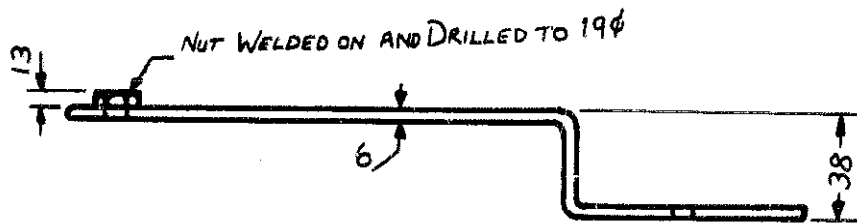

NUT WELDED ON AND DRILLED TO  $19\phi$

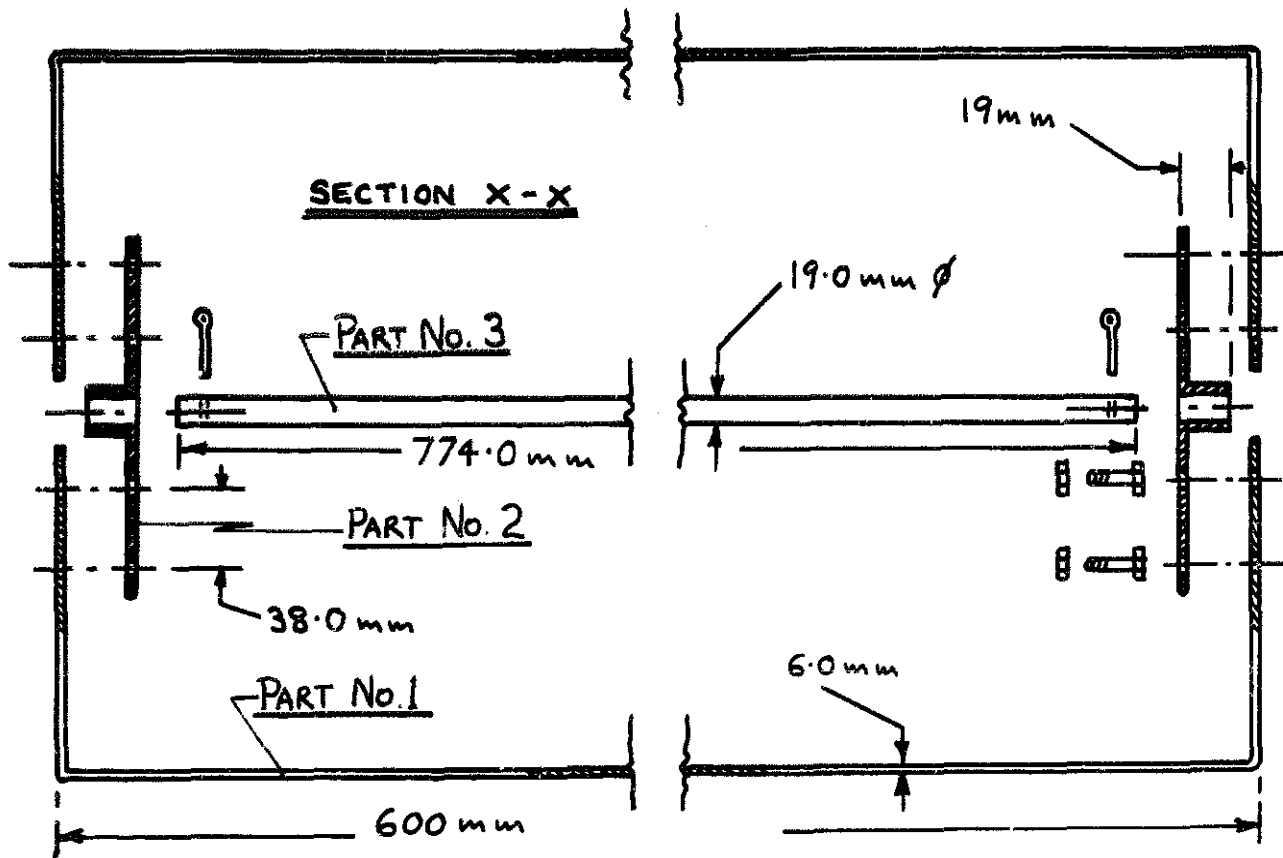
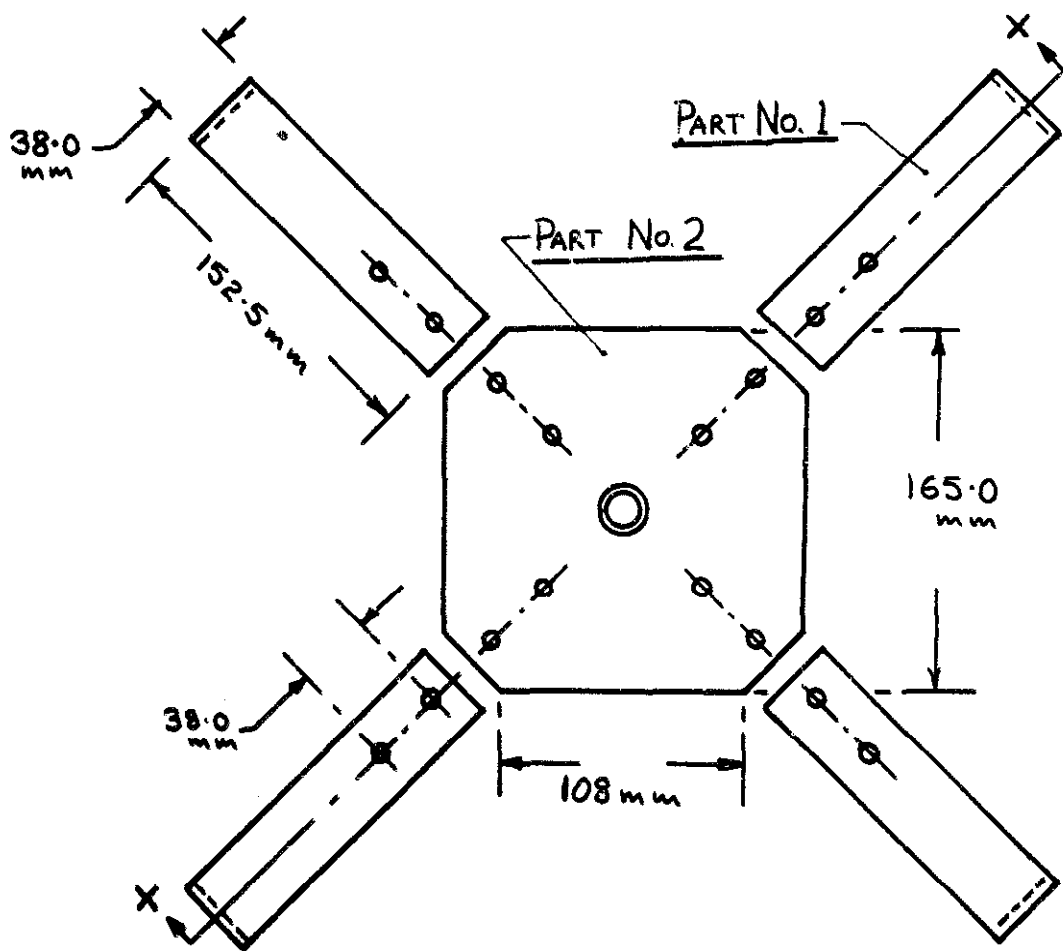

PART No. 6

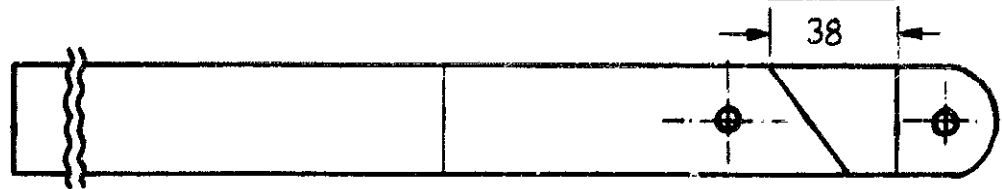
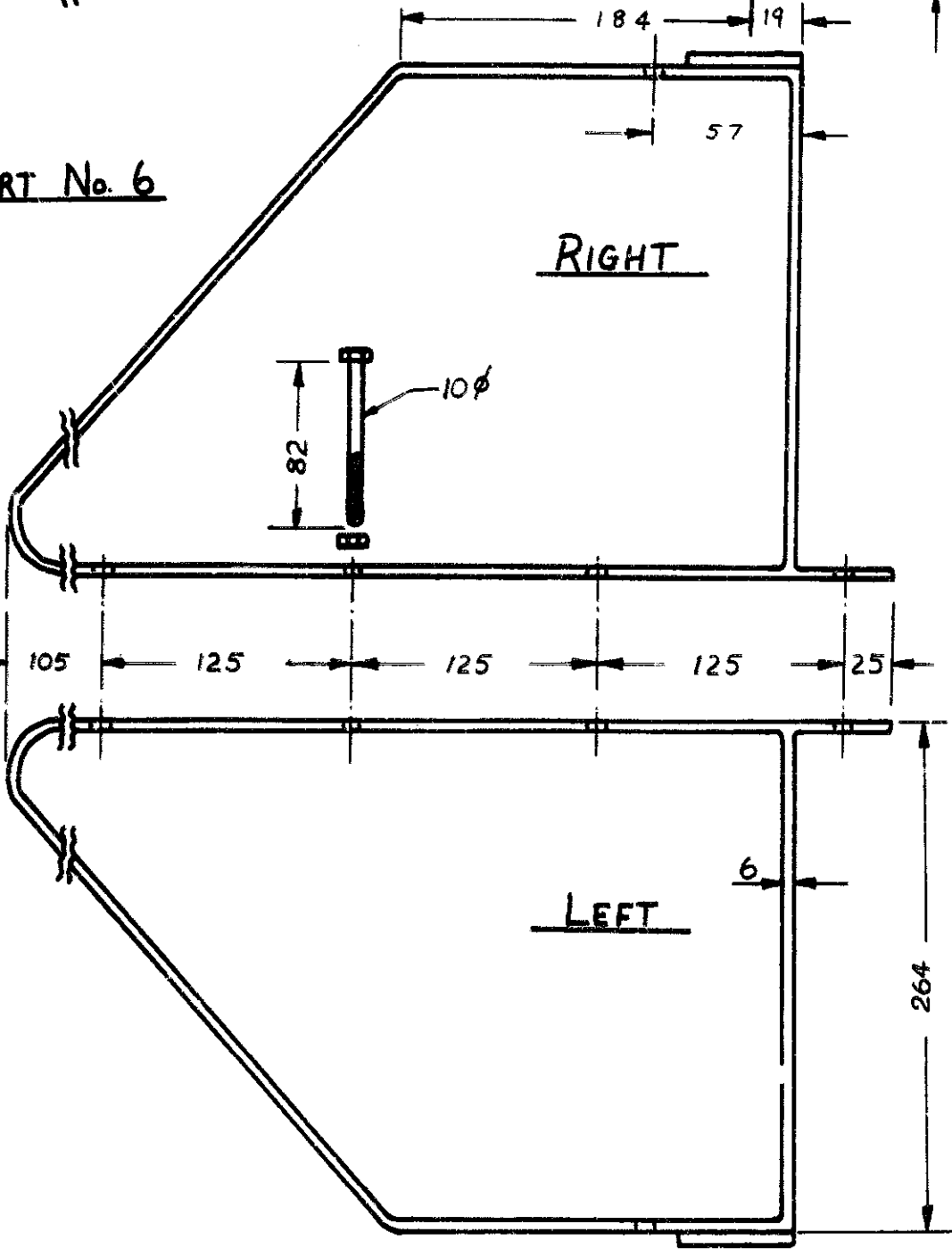
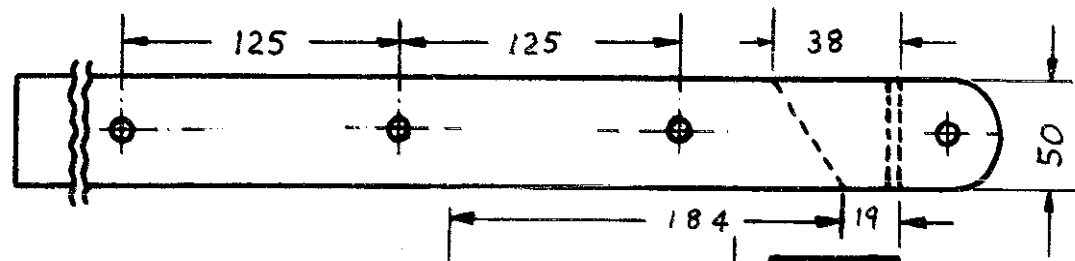

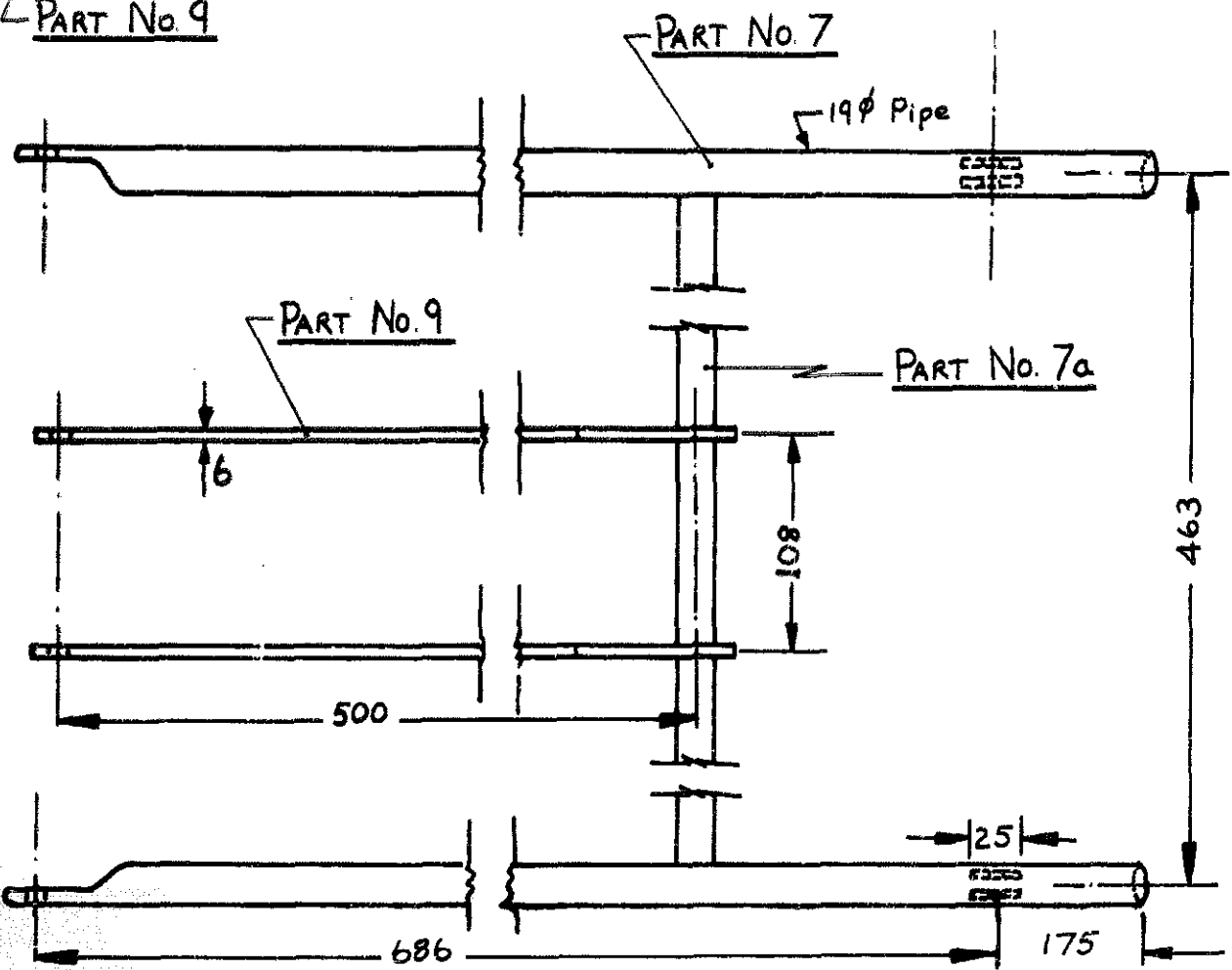
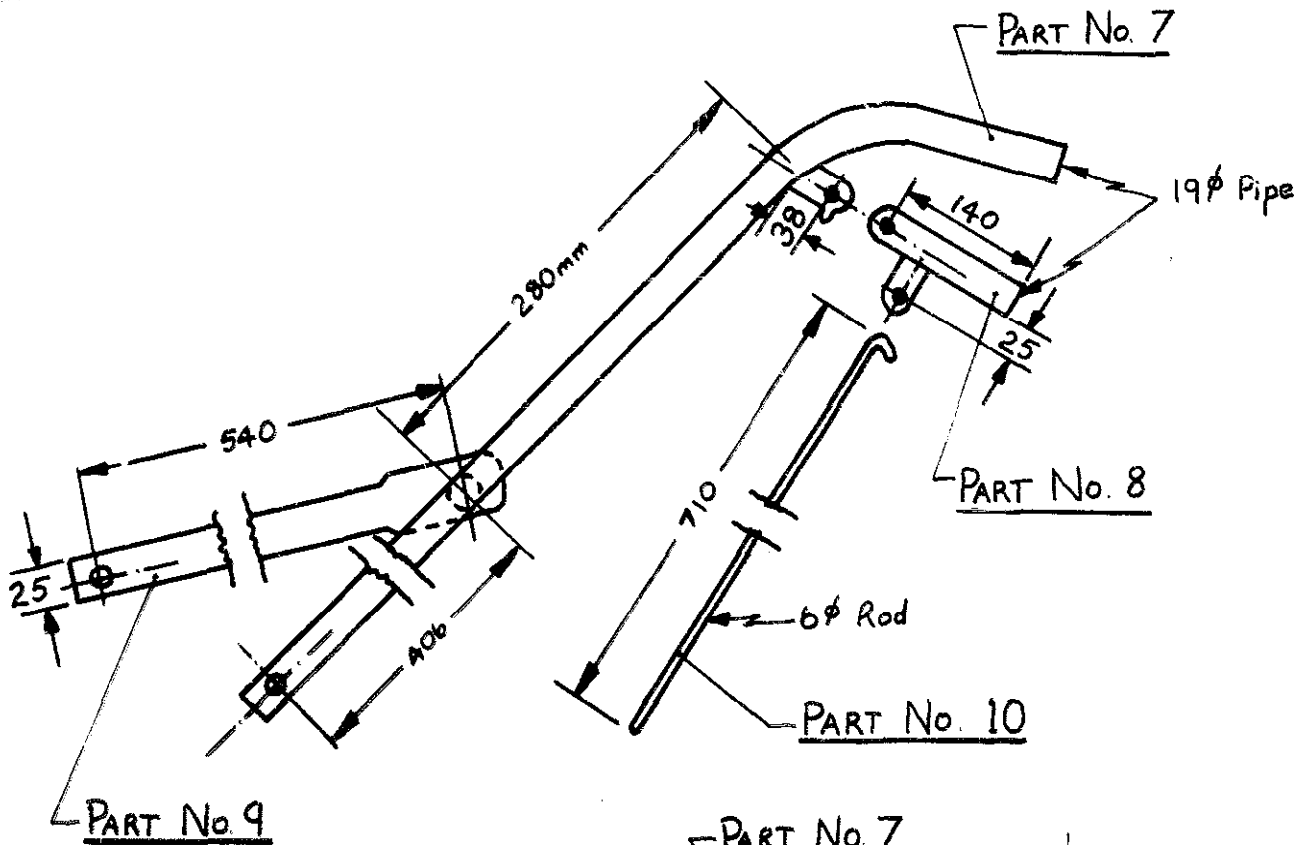

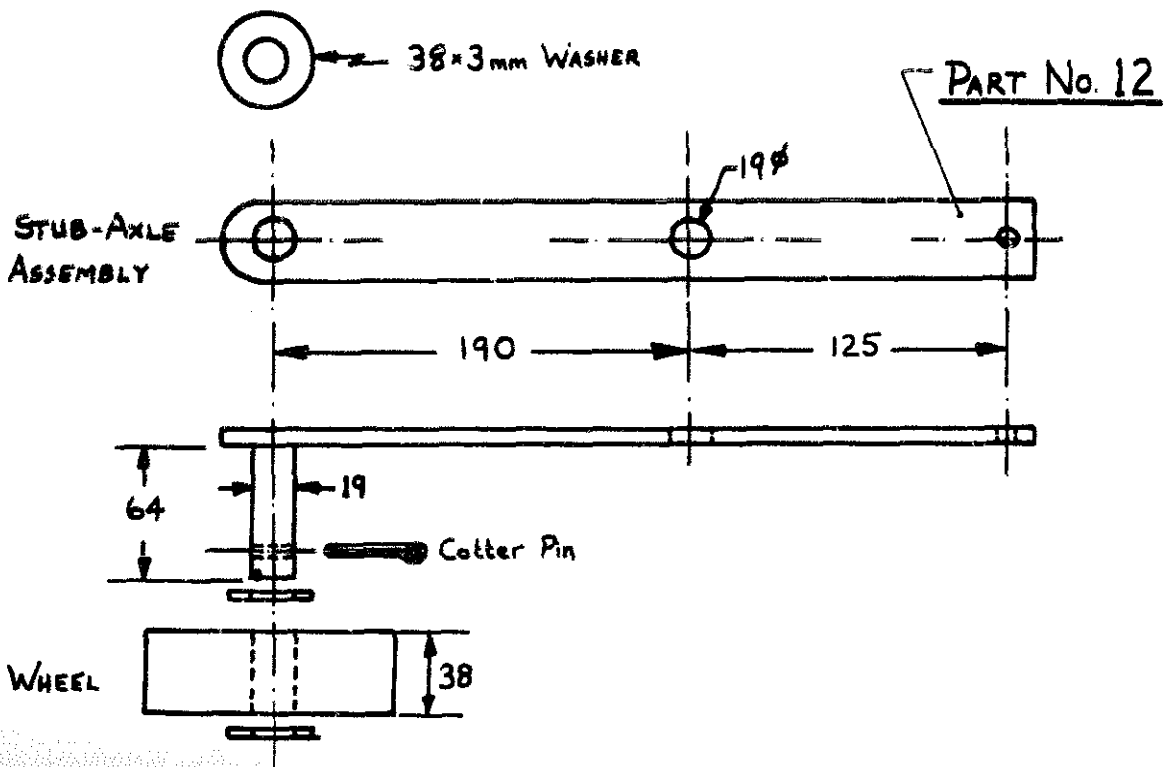
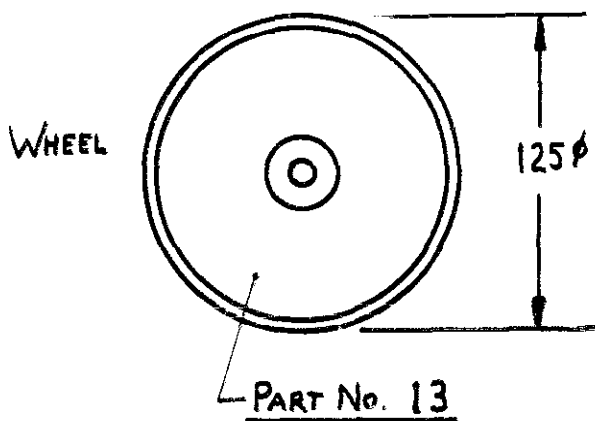
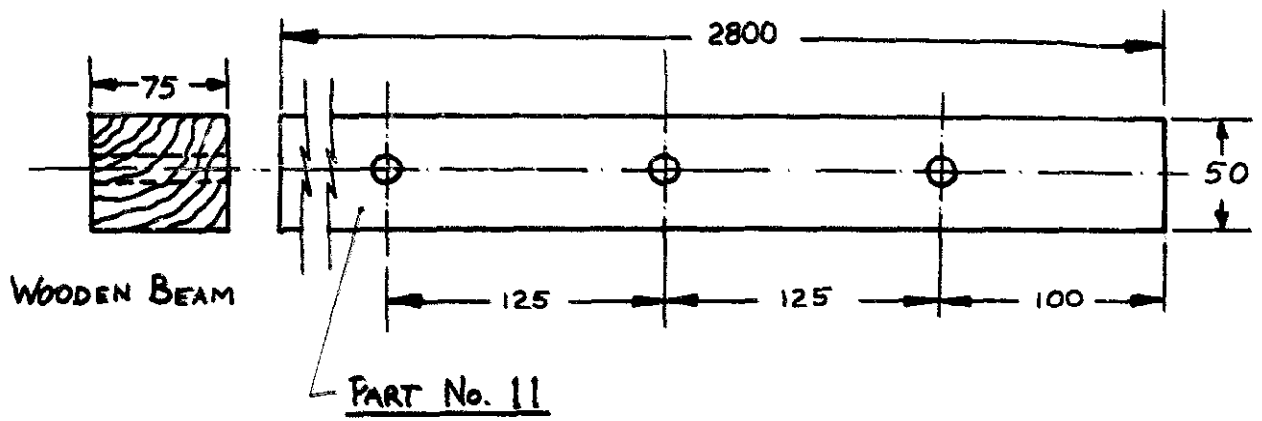



37

**AT** MICROFICHE  
REFERENCE  
LIBRARY

A project of Volunteers in Asia

Foot Powered Thresher

ITDG Agricultural Equipment and Tools No. 37

Published by:

Intermediate Technology Publications, Ltd.  
9 King Street  
London WC2E 8HN  
United Kingdom

Paper copies are 0.50 British pounds.

Available from:

Intermediate Technology Publications, Ltd.  
9 King Street  
London WC2E 8HN  
United Kingdom

Reproduced by permission of Intermediate  
Technology Publications, Ltd.

Reproduction of this microfiche document in any  
form is subject to the same restrictions as those  
of the original document.

# FOOT POWERED THRESHER

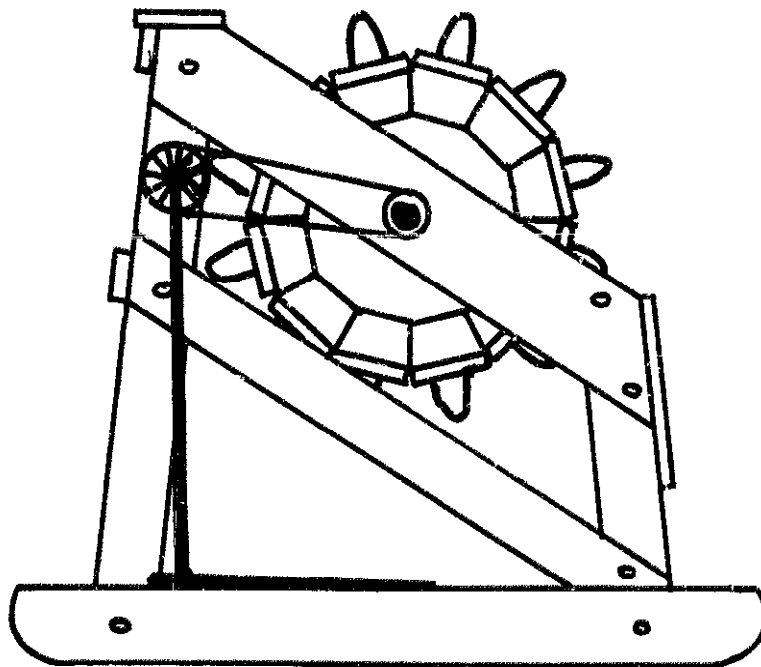



1. Using the threshing

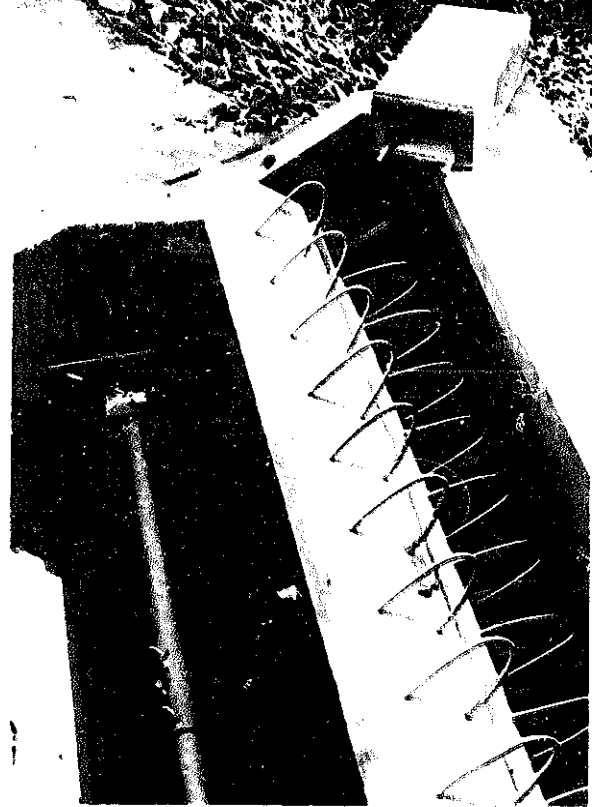

2. Two of the boards have been removed from the drum to show the construction details of the inside. Note the plates to hold the drum firmly to the shaft. The shaft is in two pieces, with a connector for ease of assembly. Inside the threshing assembly at upper right can be seen the adjustable plate for the large sprocket shaft assembly. On top of the threshing is shown the tool for inserting wire hoops into the drum. Undersize holes are drilled, and pre-formed loops are driven into the holes with the tool and hammer.

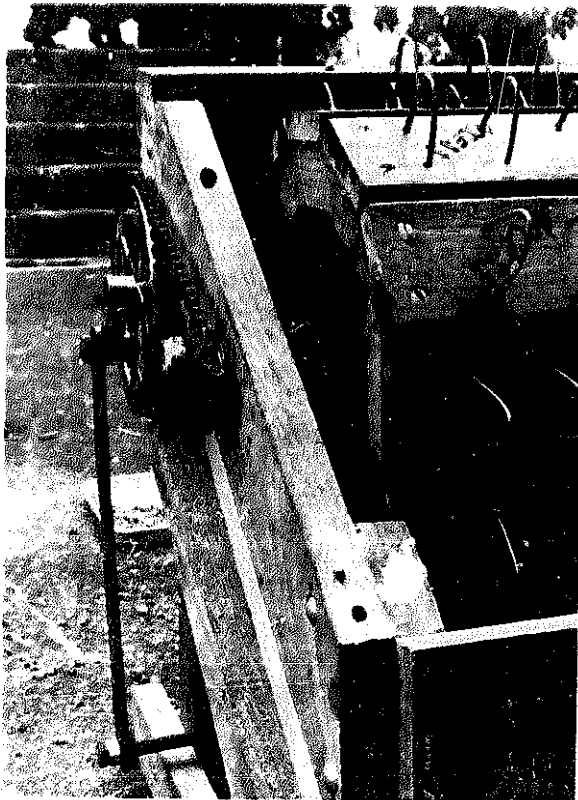

3. Wire loops 2" apart, with alternate rows offset, strike the grain from the stalk. Note the holes in the frame for the steel rod hoops, which hold a cloth cover. A simple chain guard should be added for safety.

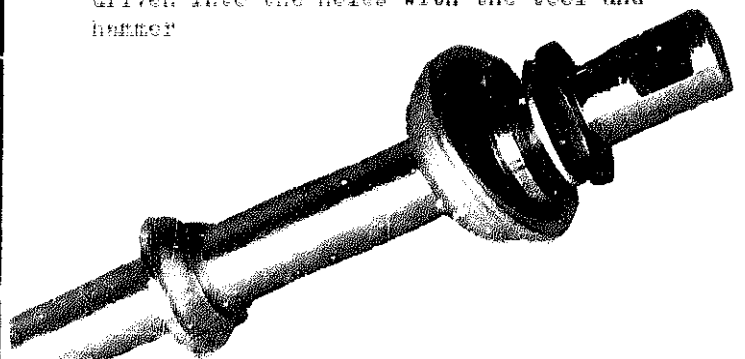

4. This is the type of bicycle pedal shaft assembly used (minus the ball bearings), showing at one end the bearing cup, adjustable cone, washer and lock-nut. The shaft for the large sprocket is used intact. The one for the drum is cut in half and extended with ordinary mild steel round bar.



STEEL PLATE  $\frac{1}{8} \times 2 \times 4$   
 (BOTH SIDES OF FRAME FOR  
 ADJUSTING CHAIN TENSION)

STEERING CUP  
 BALL  
 CONE (ADJUSTABLE)  
 WASHER

SHAFT

LOCK NUT

THRASHER FRAME

ADJUSTING BOLTS  
 $\frac{1}{4} \times 3\frac{1}{2}$ "

LARGE SPROCKET

TAPERED  
 COTTER

SPACER

BOLT  
 $\frac{1}{2} \times 1$ "

LOCK NUT

NUT WELDED  
 TO PEDAL  
 ARM

CONNECTING  
 ROD  
 $\frac{1}{8} \times 1$ "

### SECTION OF BICYCLE PEDAL SHAFT ASSEMBLY FOR LARGE SPROCKET

DRILL UNDERSIZE  
 HOLES IN WOOD  
 AND DRIVE LOOP  
 WITH HAMMER

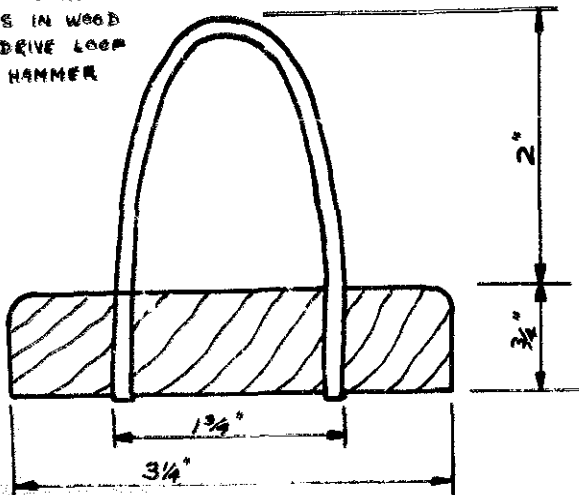

WIRE LOOP

## FOOT POWERED THRESHER

### Source

Melanesian Council of Churches. P.O.Box 80, Lae, Papua New Guinea.

I.T.D.'s. has not yet had an opportunity to build or test this thresher and the information given below was supplied by B.David Williams Jr., Agricultural Secretary of the Melanesian Council of Churches.

### Description.

Threshers of this type have been used in large numbers in Asia, but have generally been factory-built and have used spur gear drives and expensive bearings. This Melanesian Council of Churches design substitutes bicycle chain and sprockets for the gears and employs bearings taken from bicycle pedal shafts. To make the thresher, some electric welding and use of a drill press are required, but all other operations can be done with simple hand tools.

The thresher is suitable for rice and also sorghum, oats and other small grains. When the treadle is operated the drum rotates at 250 to 300 revolutions per minute. The wire loops on the drum are the "teeth" which strike the grain off the stalks. This machine does not separate the chaff from the grain and therefore winnowing is still necessary.

The threshing is done by holding a bundle of unthreshed grain firmly in the hands, beating and twisting the bundle lightly against the drum, which revolves away from the worker, and throwing the bundle of threshed straw aside. The good grains fall down upon a canvas or plastic sheet, which is placed under the thresher.

The work of cleaning the grain will be greatly facilitated by putting the threshed material into a box with  $\frac{3}{4}$  inch wire mesh screen on top. This will remove many of the broken stems and longer trash.

To maximize the output of this machine, the work should be systematically organized. The following recommendations for organizing field procedures when using treadle operated threshers come from the International Rice Research Institute in the Philippines and are based on observations of experienced workers in Taiwan.\*

1. The straw is cut with a scythe in one hand and gathered in the other. Each single handful of straw is laid aside on the stubble parallel to the previous ones and left to dry one to two days.
2. The sled-mounted pedal thresher with a box and screen is brought into the field by 3 to 5 persons who work as a team.
3. Each person has a cord about 50cm long attached to one wrist and free at the other end. He slips his hand under 4 to 8 handfuls of the dry straw and binds the large bundle by wrapping the free end of the cord around the bundle. This technique permits one hand to hold the straw firmly.

4. The crew members rotate in a circle. While one or two are threshing, the others are returning, gathering, and bringing new bundles. Each person threshes the bundle that he gathers by pedaling with a rhythmic body action while holding and twisting the bundle. The inertia of the cylinder keeps the thresher going as the labourers take turns threshing, gathering, and bringing in new bundles.
5. After threshing the straw is discarded in a small pile. The sled-mounted thresher is moved in 5 to 10 metre stages so that the haul distance is always short and straw piles are small.
6. The threshed grain accumulates in the box along with some flag leaves and chaff. The leaves are removed and the grain and chaff are sacked for drying and cleaning.

Taiwan reports indicate that experienced workers can thresh approximately 1,000 kg. of paddy per day with a treadle operated thresher if the material is dry. CECOCO ( a dealer in small agricultural equipment in Japan) reports 115 kg. of paddy per hour as the capacity of a similar machine. The amount of work done will vary greatly according to conditions. Johnson, Casem, and Manalo report \*\* that five women in the Philippines with one thresher were able to thresh about 500 kg. of grain in 8 to 10 hours, working with wet materials from a stack in a muddy field. Under the latter conditions threshing by hand would be nearly impossible.

#### Engine Driven Thresher.

Those who want a simple engine-driven thresher can build a similar machine, but with a wider drum, for example, 36 inches; with a stronger shaft, say 3/4 inch; and with a large pulley on one side. A three to five horsepower engine will be sufficient, and in this case approximately 400 revolutions per minute would be best.

#### References.

- \* Johnson, Casem, and Manalo, "Labor and Procedure for The Pedal Thresher", International Rice Research Institute Technical Paper No.2 September 1966.

\*\* op. cit.

### CONVERSION TABLE

8th fractions and inches to millimetres (mm)

Inches	0 in	1 in	2 in	3 in
Fractions	mm	25.400	50.800	76.200
1/8 in	3.175	28.575	53.975	79.375
1/4 in	6.350	31.750	57.150	82.550
3/8 in	9.525	34.925	60.325	85.725
1/2 in	12.700	38.100	63.500	88.900
5/8 in	15.875	41.275	66.675	92.075
3/4 in	19.050	44.450	69.850	95.250
7/8 in	22.225	47.625	73.025	98.425



4. The crew members rotate in a circle. While one or two are threshing, the others are returning, gathering, and bringing new bundles. Each person threshes the bundle that he gathers by pedaling with a rhythmic body action while holding and twisting the bundle. The inertia of the cylinder keeps the thresher going as the labourers take turns threshing, gathering, and bringing in new bundles.
5. After threshing the straw is discarded in a small pile. The sled-mounted thresher is moved in 5 to 10 metre stages so that the haul distance is always short and straw piles are small.
6. The threshed grain accumulates in the box along with some flag leaves and chaff. The leaves are removed and the grain and chaff are sacked for drying and cleaning.

Taiwan reports indicate that experienced workers can thresh approximately 1,000 kg. of paddy per day with a treadle operated thresher if the material is dry. CEGOCO ( a dealer in small agricultural equipment in Japan) reports 115 kg. of paddy per hour as the capacity of a similar machine. The amount of work done will vary greatly according to conditions. Johnson, Casem, and Manalo report \*\* that five women in the Philippines with one thresher were able to thresh about 500 kg. of grain in 8 to 10 hours, working with wet materials from a stack in a muddy field. Under the latter conditions threshing by hand would be nearly impossible.

Engine Driven Thresher.

Those who want a simple engine-driven thresher can build a similar machine, but with a wider drum, for example, 36 inches; with a stronger shaft, say 3/4 inch; and with a large pulley on one side. A three to five horsepower engine will be sufficient, and in this case approximately 400 revolutions per minute would be best.

References.

\* Johnson, Casem, and Manalo, "Labor and Procedure for The Pedal Thresher", International Rice Research Institute Technical Paper No.2 September 1966.

\*\* op. cit.

CONVERSION TABLE

8th fractions and inches to millimetres (mm)

Inches	0 in.	1 in.	2 in.	3 in.
Fractions	mm	25-400	50-800	75-200
1/8 in.	3-175	28-575	53-975	79-375
1/4 in.	6-350	31-750	57-150	82-550
3/8 in.	9-525	34-925	60-325	85-725
1/2 in.	12-700	38-100	63-500	88-900
5/8 in.	15-875	41-275	66-675	92-075
3/4 in.	19-050	44-450	69-850	95-250
7/8 in.	22-225	47-625	73-025	98-425