

THE No 1 UK MAGAZINE FOR ELECTRONICS TECHNOLOGY & COMPUTER PROJECTS

EPE EVERYDAY PRACTICAL ELECTRONICS

www.epemag.com

LIGHTNING DETECTOR

AM RADIO TECHNOLOGY APPLIED TO STORM ALERT

DIGITAL SPIRIT LEVEL

- Works with 14-bit, three-axis MEMS accelerometer
- PIC control uses sophisticated digital signal processing
- Accurate to 0.1° over 360°
- Four-digit LED display



INTERPLANETARY VOICE

'EXTERMINATE!' NEVER SOUNDED SO GOOD

SEMTEST – PART 2

COMPLETE CIRCUIT DESCRIPTION

OF THE ULTIMATE SILICON CHECKER

WIN A
MICROCHIP
XLP 8-Bit
Development
Board

Jump Start

DC Motor Controller – perfect for
dynamic models and projects



Raspberry Pi
More fruity fillings

MARCH 2013 £4.40



One platform for 8-, 16- and 32-bit development - with Microchip's MPLAB® X IDE

MPLAB® X Common Integrated Development Environment

- 8-bit PIC® Microcontrollers**
128K Flash
16 MIPS
250+ Options
- 16-bit PIC® Microcontrollers & dsPIC® Digital Signal Controllers**
256K Flash
70 MIPS
150+ Options
- 32-bit PIC® Microcontrollers**
512K Flash
1.5 DMIPS/MHz
80 MHz

500+ complementary Analog & Memory solutions

MPLAB X • Open-Source • Cross-Platform • Universal
Integrated Development Environment

MPLAB® X IDE is the free, integrated toolset for all of Microchip's 900+ 8-, 16- and 32-bit PIC® Microcontrollers, dsPIC® Digital Signal Controllers, and memory devices. Based on the open-source NetBeans platform, MPLAB X runs on Windows® OS, MAC® OS and Linux, supports many third-party tools, and is compatible with many NetBeans plug-ins.

MPLAB XC compilers help increase code speed of any PIC® Microcontroller or dsPIC® digital signal controller by 30%, whilst also cutting code size by 35%. These new compilers give designers the choice of Free, Standard or Pro code optimisation levels for 8-bit, 16- or 32-bit development, or a single C compiler suite to support all Microchip Microcontrollers and digital signal controllers.

Microchip's tool chain of compatible compilers and debugger/programmers operate seamlessly within the universal, cross platform and open-source MPLAB® X integrated development environment, reducing both learning curves and tool investments.



START DEVELOPING TODAY

Download a free copy of MPLAB X and choose from a choice of new C compilers:

- MPLAB XC8 for 8-bit MCUs
- MPLAB XC16 for 16-bit MCUs and DSCs
- MPLAB XC32 for 32-bit MCUs
- MPLAB XC Suite for all 900+ PIC MCUs and dsPIC DSCs.

Evaluate MPLAB X today! www.microchip.com/get/eumplabx



Microcontrollers • Digital Signal Controllers • Analog • Memory • Wireless

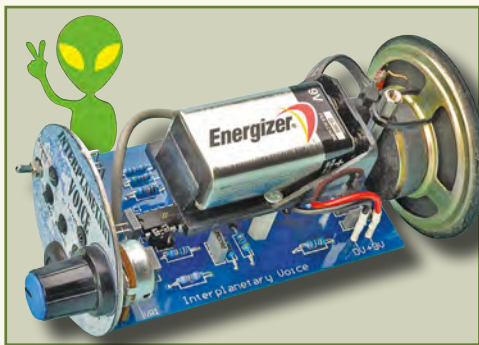

© Wimborne Publishing Ltd 2013. Copyright in all drawings, photographs and articles published in *EVERYDAY PRACTICAL ELECTRONICS* is fully protected, and reproduction or imitations in whole or in part are expressly forbidden.

Our April 2013 issue will be published on Thursday 7 March 2013, see page 80 for details.

Everyday Practical Electronics, March 2013

Projects and Circuits

- LIGHTNING DETECTOR** 10
 by John Clarke
 Work and play safely in the open with our atmospheric megavolt dodger!
- SEMTEST - PART 2** 18
 by Jim Rowe
 Introducing the full circuit of this versatile discrete component checker
- DIGITAL SPIRIT LEVEL** 28
 By Andrew Levido
 Not just an end to wonky shelves, but a great introduction to MEMS components
- INTERPLANETARY VOICE** 38
 by John Clarke
 Exterminate! – the ultimate Dalek and Darth Vader voice project
- INGENUITY UNLIMITED** 68
 Electric blanket controller – Turn-up the heat!

Series and Features

- TECHNO TALK** by Mark Nelson 27
 Not what you expected?
- MAX'S COOL BEANS** by Max The Magnificent 46
 Grains of sand... Wireless mesh networked propeller beanie hats...
 What are the chances...?
- JUMP START** by Mike and Richard Tooley 48
 DC Motor Controller
- RASPBERRY PI** by Mike Hibbett 54
 Further investigation
- PIC N' MIX** by Mike Hibbett 57
 Increasing the speed – saving power
- CIRCUIT SURGERY** by Ian Bell 60
 Flip-flop architecture
- PRACTICALLY SPEAKING** by Robert Penfold 65
 Project X!
- NET WORK** by Alan Winstanley 73
 Pocket the best!... Far sited... Herding cats

Regulars and Services

- EDITORIAL** 7
 Lightning, Daleks and accelerometers
- NEWS** – Barry Fox highlights technology's leading edge 8
 Plus everyday news from the world of electronics
- MICROCHIP READER OFFER** 17
EPE Exclusive – Win a Microchip XLP 8-Bit Development Board
- SUBSCRIBE TO *EPE*** and save money 36
- EPE* BACK ISSUES** Did you miss these? 56
- CD-ROMS FOR ELECTRONICS** 70
 A wide range of CD-ROMs for hobbyists, students and engineers
- DIRECT BOOK SERVICE** 75
 A wide range of technical books available by mail order, plus more CD-ROMs
- EPE* PCB SERVICE** 78
 PCBs for *EPE* projects
- ADVERTISERS INDEX** 79
- NEXT MONTH!** – Highlights of next month's *EPE* 80

01279

**Credit Card
Sales**

467799

PIC & ATMEL Programmers

We have a wide range of low cost PIC and ATMEL Programmers. Complete range and documentation available from our web site.

Programmer Accessories:

40-pin Wide ZIF socket (ZIF40W) £14.95
18Vdc Power supply (PSU121) £22.95
Leads: Parallel (LDC136) £3.95 / Serial (LDC441) £3.95 / USB (LDC644) £2.95

USB & Serial Port PIC Programmer



USB/Serial connection. Header cable for ICSP. Free Windows XP software. See website for PICs supported. ZIF Socket and USB lead extra. 18Vdc.

Kit Order Code: 3149EKT - £49.95
Assembled Order Code: AS3149E - £64.95
Assembled with ZIF socket Order Code: AS3149EZIF - £74.95

USB Flash PIC Programmer

USB PIC programmer for a wide range of Flash devices—see website for details. Free Windows Software. ZIF Socket and USB lead not included. Powered via USB port - no external power supply required.



Assembled with ZIF socket Order Code: AS3150ZIF - £64.95

ATMEL 89xxxx Programmer



Uses serial port and any standard terminal comms program. 4 LED's display the status. ZIF sockets not included. Supply: 16Vdc.

Kit Order Code: 3123KT - £28.95
Assembled Order Code: AS3123 - £39.95

Introduction to PIC Programming

Go from complete beginner to burning a PIC and writing code in no time! Includes 49 page step-by-step PDF Tutorial Manual, Programming Hardware (with LED test section), Win 3.11—XP Programming Software (Program, Read, Verify & Erase), and 1 rewritable PIC16F84A that you can use with different code (4 detailed examples provided for you to learn from). PC parallel port.
Kit Order Code: 3081KT - £16.95
Assembled Order Code: AS3081 - £24.95



PIC Programmer Board

Low cost PIC programmer board supporting a wide range of Microchip® PIC™ microcontrollers. Requires PC serial port. Windows interface supplied.



Kit Order Code: K8076KT - £34.95

PIC Programmer & Experimenter Board

The PIC Programmer & Experimenter Board with test buttons and LED indicators to carry out educational experiments, such as the supplied programming examples. Includes a 16F627 Flash Microcontroller that can be reprogrammed up to 1000 times for experimenting at will. Software to compile and program your source code is included.
Kit Order Code: K8048KT - £34.95
Assembled Order Code: VM111 - £44.95



Controllers & Loggers

Here are just a few of the controller and data acquisition and control units we have. See website for full details. 12Vdc PSU for all units: Order Code PSU446 £8.95

USB Experiment Interface Board

5 digital input channels and 8 digital output channels plus two analogue inputs and two analogue outputs with 8 bit resolution.



Kit Order Code: K8055NKT - £29.95
Assembled Order Code: VM110N - £43.95

Rolling Code 4-Channel UHF Remote

State-of-the-Art. High security. 4 channels. Momentary or latching relay output. Range up to 40m. Up to 15 Tx's can be learnt by one Rx (kit includes one Tx but more available separately). 4 indicator LED's. Rx: PCB 77x85mm, 12Vdc/6mA (standby). Two & Ten Channel versions also available.



Kit Order Code: 3180KT - £54.95
Assembled Order Code: AS3180 - £64.95

Computer Temperature Data Logger

Serial port 4-channel temperature logger. °C or °F. Continuously logs up to 4 separate sensors located 200m+ from board. Wide range of tree software applications for storing/using data. PCB just 45x45mm. Powered by PC. Includes one DS1820 sensor.
Kit Order Code: 3145KT - £19.95
Assembled Order Code: AS3145 - £26.95
Additional DS1820 Sensors - £4.95 each



Remote Control Via GSM Mobile Phone

Place next to a mobile phone (not included). Allows toggle or auto-timer control of 3A mains rated output relay from any location with GSM coverage.



Kit Order Code: MK160KT - £11.95

Most items are available in kit form (KT suffix) or pre-assembled and ready for use (AS prefix).

4-Ch DTMF Telephone Relay Switcher

Call your phone number using a DTMF phone from anywhere in the world and remotely turn on/off any of the 4 relays as desired. User settable Security Password, Anti-Tamper, Rings to Answer, Auto Hang-up and Lockout. Includes plastic case. 130 x 110 x 30mm. Power: 12Vdc.
Kit Order Code: 3140KT - £79.95
Assembled Order Code: AS3140 - £94.95



8-Ch Serial Port Isolated I/O Relay Module

Computer controlled 8 channel relay board. 5A mains rated relay outputs and 4 opto-isolated digital inputs (for monitoring switch states, etc). Useful in a variety of control and sensing applications. Programmed via serial port (use our new Windows interface, terminal emulator or batch files). Serial cable can be up to 35m long. Includes plastic case 130x100x30mm. Power: 12Vdc/500mA.
Kit Order Code: 3108KT - £74.95
Assembled Order Code: AS3108 - £89.95



Infrared RC 12-Channel Relay Board

Control 12 onboard relays with included infrared remote control unit. Toggle or momentary. 15m+ range. 112 x 122mm. Supply: 12Vdc/0.5A
Kit Order Code: 3142KT - £64.95
Assembled Order Code: AS3142 - £74.95



Audio DTMF Decoder and Display

Detect DTMF tones from tape recorders, receivers, two-way radios, etc using the built-in mic or direct from the phone line. Characters are displayed on a 16 character display as they are received and up to 32 numbers can be displayed by scrolling the display. All data written to the LCD is also sent to a serial output for connection to a computer. Supply: 9-12V DC (Order Code PSU303). Main PCB: 55x95mm.
Kit Order Code: 3153KT - £37.95
Assembled Order Code: AS3153 - £49.95



3x5Amp RGB LED Controller with RS232

3 independent high power channels. Preprogrammed or user-editable light sequences. Standalone option and 2-wire serial interface for microcontroller or PC communication with simple command set. Suitable for common anode RGB LED strips, LEDs and incandescent bulbs. 56 x 39 x 20mm. 12A total max. Supply: 12Vdc.
Kit Order Code: 8191KT - £29.95
Assembled Order Code: AS8191 - £39.95



Hot New Products!

Here are a few of the most recent products added to our range. See website or join our email Newsletter for all the latest news.

4-Channel Serial Port Temperature Monitor & Controller Relay Board

4 channel computer serial port temperature monitor and relay controller with four inputs for Dallas DS18S20 or DS18B20 digital thermometer sensors (£3.95 each). Four 5A rated relay channels provide output control. Relays are independent of sensor channels, allowing flexibility to setup the linkage in any way you choose. Commands for reading temperature and relay control sent via the RS232 interface using simple text strings. Control using a simple terminal / comms program (Windows HyperTerminal) or our free Windows application software. Kit Order Code: 3190KT - **£84.95**
Assembled Order Code: AS3190 - **£99.95**



40 Second Message Recorder

Feature packed non-volatile 40 second multi-message sound recorder module using a high quality Winbond sound recorder IC. Stand-alone operation using just six onboard buttons or use onboard SPI interface. Record using built-in microphone or external line in. 8-24 Vdc operation. Just change one resistor for different recording duration/sound quality. sampling frequency 4-12 kHz. Kit Order Code: 3188KT - **£29.95**
Assembled Order Code: AS3188 - **£37.95**
120 second version also available



Bipolar Stepper Motor Chopper Driver

Get better performance from your stepper motors with this dual full bridge motor driver based on SGS Thompson chips L297 & L298. Motor current for each phase set using on-board potentiometer. Rated to handle motor winding currents up to 2 Amps per phase. Operates on 9-36Vdc supply voltage. Provides all basic motor controls including full or half stepping of bipolar steppers and direction control. Allows multiple driver synchronization. Perfect for desktop CNC applications. Kit Order Code: 3187KT - **£39.95**
Assembled Order Code: AS3187 - **£49.95**

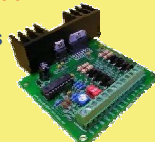

Video Signal Cleaner

Digitally cleans the video signal and removes unwanted distortion in video signal. In addition it stabilises picture quality and luminance fluctuations. You will also benefit from improved picture quality on LCD monitors or projectors. Kit Order Code: K8036KT - **£29.95**
Assembled Order Code: VM106 - **£44.95**



Most items are available in kit form (KT suffix) or assembled and ready for use (AS prefix).

Motor Speed Controllers

Here are just a few of our controller and driver modules for AC, DC, Unipolar/Bipolar stepper motors and servo motors. See website for full details.

DC Motor Speed Controller (100V/7.5A)

Control the speed of almost any common DC motor rated up to 100V/7.5A. Pulse width modulation output for maximum motor torque at all speeds. Supply: 5-15Vdc. Box supplied. Dimensions (mm): 60Wx100Lx60H. Kit Order Code: 3067KT - **£19.95**
Assembled Order Code: AS3067 - **£27.95**



Bidirectional DC Motor Speed Controller

Control the speed of most common DC motors (rated up to 32Vdc/10A) in both the forward and reverse direction. The range of control is from fully OFF to fully ON in both directions. The direction and speed are controlled using a single potentiometer. Screw terminal block for connections. Kit Order Code: 3166v2KT - **£23.95**
Assembled Order Code: AS3166v2 - **£33.95**



Computer Controlled / Standalone Unipolar Stepper Motor Driver

Drives any 5-35Vdc 5, 6 or 8-lead unipolar stepper motor rated up to 6 Amps. Provides speed and direction control. Operates in stand-alone or PC-controlled mode for CNC use. Connect up to six 3179 driver boards to a single parallel port. Board supply: 9Vdc. PCB: 80x50mm. Kit Order Code: 3179KT - **£17.95**
Assembled Order Code: AS3179 - **£24.95**



Computer Controlled Bi-Polar Stepper Motor Driver

Drive any 5-50Vdc, 5 Amp bi-polar stepper motor using externally supplied 5V levels for STEP and DIRECTION control. Opto-isolated inputs make it ideal for CNC applications using a PC running suitable software. Board supply: 8-30Vdc. PCB: 75x85mm. Kit Order Code: 3158KT - **£24.95**
Assembled Order Code: AS3158 - **£34.95**



AC Motor Speed Controller (600W)

Reliable and simple to install project that allows you to adjust the speed of an electric drill or 230V AC single phase induction motor rated up to 600 Watts. Simply turn the potentiometer to adjust the motors RPM. PCB: 48x65mm. Not suitable for use with brushless AC motors. Kit Order Code: 1074KT - **£15.95**
Assembled Order Code: AS1074 - **£23.95**



See www.quasarelectronics.com for lots more DC, AC and Stepper motor drivers



QUASAR
electronics
The Electronic Kit Specialists Since 1993

Credit Card Sales
01279 467 799

Electronic Project Labs

Great introduction to the world of electronics. Ideal gift for budding electronics expert!

500-in-1 Electronic Project Lab

Top of the range. Complete self-contained electronics course. Takes you from beginner to 'A' Level standard and beyond! Contains all the hardware and manuals to assemble 500 projects. You get 3 comprehensive course books (total 368 pages) - *Hardware Entry Course*, *Hardware Advanced Course* and a microprocessor based *Software Programming Course*. Each book has individual circuit explanations, schematic and connection diagrams. Suitable for age 12+. Order Code EPL500 - **£179.95**
Also available: 30-in-1 £17.95, 50-in-1 £29.95, 75-in-1 £39.95 £130-in-1 £49.95 & 300-in-1 £79.95 (see website for details)



Tools & Test Equipment

We stock an extensive range of soldering tools, test equipment, power supplies, inverters & much more - please visit website to see our full range of products.

Advanced Personal Scope 2 x 240MS/s

Features 2 input channels - high contrast LCD with white backlight - full auto set-up for volt/div and time/div - recorder roll mode, up to 170h per screen - trigger mode: run - normal - once - roll ... - adjustable trigger level and slope and much more. Order Code: APS230 - ~~£499.95~~ **£394.95**



Personal Scope 10MS/s

The Personal Scope is not a graphical multimeter but a complete portable oscilloscope at the size and the cost of a good multimeter. Its high sensitivity - down to 0.1mV/div - and extended scope functions make this unit ideal for hobby, service, automotive and development purposes. Because of its exceptional value for money, the Personal Scope is well suited for educational use. Order Code: HPS10 - ~~£189.95~~ **£139.95**
See website for more super deals!



www.quasarelectronics.com

Secure Online Ordering Facilities • Full Product Listing, Descriptions & Photos • Kit Documentation & Software Downloads

Everyday Practical Electronics

March 2013

Featured Kits



Everyday Practical Electronics Magazine has been publishing a series of popular kits by the acclaimed Silicon Chip Magazine Australia. These projects are 'bullet proof' and already tested Down Under. All Jaycar kits are supplied with specified board components, quality fibreglass tinned PCBs and have clear English instructions. Watch this space for future featured kits.

Theremin Synthesiser Kit MkII

Cat. KC-5475

Create your own eerie science fiction sound effects by simply moving your hand near the antenna. Easy to set up and build. Complete kit contains PCB with overlay, pre-machined case and all specified components.

- PCB: 85 x 145mm

£27.25*



USB Power Monitor Kit

Cat. KC-5516

Plug this kit inline with a USB device to display the current that is drawn at any given time. Check the total power draw from an unpowered hub and its attached devices or what impact a USB device has on your laptop battery life. Displays current, voltage or power, is auto-ranging and will read as low as a few microamps and up to over an amp. Kit supplied with double sided, soldermasked and screen-printed PCB with SMD components presoldered, LCD screen, and components.

- PCB: 65 x 36mm

£21.75*



DC Relay Switch Kit

Cat. KC-5434

An extremely useful and versatile kit that enables you to use a tiny trigger current - as low as 400µA at 12V to switch up to 30A at 50VDC. It has an isolated input and is suitable for a variety of triggering options. Kit includes PCB with overlay and all electronic components with clear instructions.

£6.25*



Garbage and Recycling Reminder Kit

Cat. KC-5518

Easy to build kit that reminds you when to put which bin out by flashing the corresponding brightly coloured LED. Up to four bins can be individually set to weekly, fortnightly or alternate week or fortnight cycle. Kit supplied with silk-screened PCB, black enclosure (83 x 54 x 31mm), pre-programmed PIC, battery and PCB mount components.

- PCB: 75 x 47mm

£11.00*

Note: Product will vary from photo shown

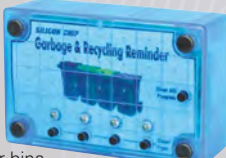

High-Power Class-D Audio Amplifier Kit

Cat. KC-5514

High quality amplifier boasting 250WRMS output into 4 ohms, 150W into 8 ohms and can be bridged with a second kit for 450W into 8 ohms. Features include high efficiency (90% @ 4 ohm), low distortion and noise (<0.01%), and over-current, over-temperature, under-voltage, over-voltage and DC offset protection. Kit supplied with double sided, soldermasked and screen-printed silk-screened PCB with SMD IC pre-soldered, heatsink, and electronic circuit board mounted components.

£32.75*

- Power requirements: -57V/0/+57V use KC-5517
- S/N ratio: 103dB
- Freq. response: 10Hz - 10kHz, +/- 1dB
- PCB: 117 x 167mm

Also available:

- Stereo Speaker Protector Kit to suit KC-5515 £11.00
- +/- 57V Power Supply Kit to suit KC-5517 £11.00



Programmable High Energy Ignition Kit for Cars

Cat. KC-5442

This advanced and versatile ignition system can be used on both two & four stroke engines. The system can be used to modify the factory timing or as the basis for a stand-alone ignition system with variable ignition timing, electronic coil control and kit includes PCB with overlay, programmed micro, all electronic components, and die cast box.

- Suitable for single coil systems
- Dwell adjustment
- Single or dual mapping ranges
- Max & min RPM adjustment
- PCB: 102 x 81mm

£25.50*

- Hand Programmer kit to suit KC-5386 £24.75
- Connecting Lead - 1.8mt
- (all 25 pins connected) to suit WC-7502 £6.75



'The Champion' Audio Amplifier Kit with Pre-Amplifier

Cat. KC-5519

Suitable for general-purpose audio projects and supports microphone and electric guitar input. It uses the AN7511 audio IC to deliver 2W music power into 8 ohms from a 9 to 12V supply. Features low distortion, two inputs (mixed 1:1), mute and standby control. Power from 4 - 13.5VDC. See website for specifications. Kit supplied with silk-screened PCB, heatsink and PCB mount components.

£7.25*

- PCB: 101 x 41mm



Jacob's Ladder MK3 Kit

Cat. KC-5520

A spectacular rising ladder of bright and noisy sparks for theatre special effects or to impress your friends. This improved circuit has even more zing and zap than it's previous design from April 2007 and requires the purchase of a 12V ignition coil (available from auto stores and parts recyclers). Kit supplied with silk-screened PCB, diecast enclosure (111 x 60 x 30mm), pre-programmed PIC, PCB mount components and pre-cut wire/ladder. Powered from a 12V 7Ah SLA or 12V car battery.

£18.25*

Battery not included

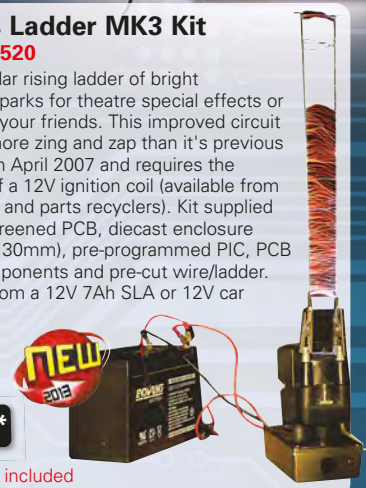

The 'Flexitimer' Kit

Cat. KA-1732

Now in it's 3rd revision by Jaycar, the flexitimer remains one of our most versatile short form projects. The flexitimer runs on 12-15V DC and switches the on-board relay once or repeatedly when the switching time is reached. Switching time can be set between 7 seconds and 2 hours in fixed steps.

- PCB: 74 x 47mm

Featured in EPE May/June 2008

£7.25*



Ultrasonic Antifouling Kit for Boats

Cat. KC-5498

Marine growth electronic antifouling systems can cost thousands. This project uses the same ultrasonic waveforms and virtually identical ultrasonic transducers mounted in a sturdy polyurethane housing. By building it yourself (which includes some potting) you save a fortune! Standard unit consists of control electronic kit and case, ultrasonic transducer, potting and gluing components and housings. The single transducer design of this kit is suitable for boats up to 10m (32ft); boats longer than about 14m will need two transducers and drivers. Basically all parts supplied in the project kit including wiring. Price includes epoxies.

- 12VDC
- Suitable for power or sail
- Could be powered by a solar panel/wind generator
- PCB: 104 x 78mm

£90.50*

Featured in EPE Sept/Oct 2012



Jaycar

Electronics

Better, More Technical

For more details on each kit visit our website www.jaycar.co.uk

FREE CALL ORDERS: 0800 032 7241

Automotive Kits for Electronic Enthusiasts

Popular Kits

10A 12VDC Motor Speed Controller Kit Cat. KC-5225

Ideal for controlling 12V DC motors in cars such as fuel injection pumps, water/air intercoolers and water injection systems. You can also use it for headlight dimming and for running 12V DC motors in 24V vehicles. The circuit incorporates a soft start feature to reduce inrush currents, especially on 12V incandescent lamps.

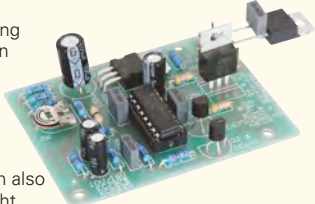

Thousands Sold!

£11.50*

- Kit includes PCB plus all electronic components to build the 10A version
- PCB: 69 x 51mm

Universal Voltage Switch Kit Cat. KC-5377

A universal module suits a range of different applications. It will trip a relay when a preset voltage is reached. Can be configured to trip with a rising or falling voltage making it suitable for a wide variety of voltage outputting devices eg., throttle position sensor, air flow sensor, EGO sensor. It also features adjustable hysteresis (the difference between trigger on/off voltage), making it extremely versatile. You could use it to trigger an extra fuel pump under high boost, anti-lag wastegate shutoff, and much more.



£12.00*

- Kit supplied with PCB, and electronic components.
- PCB: 105 x 60mm

Speedo Corrector Kit MkII Cat. KC-5435

When you modify your gearbox, diff ratio or change to a large circumference tyre, it may result in an inaccurate speedometer. This kit alters the speedometer signal up or down from 0% to 99% of the original signal. The input setup selection can be automatically selected and features an LED indicator to show when the input signal is being received. Kit supplied with PCB with overlay and all electronic components.



£20.00*

- PCB: 105 x 61mm
- Recommended box: UB3 (use HB-6013 £1.50)

High Energy Ignition Kit for Cars Cat. KC-5513

Use this kit to replace a failed ignition module or to upgrade a mechanical ignition system when restoring a vehicle. Use with virtually any ignition system that uses a single coil with points, hall effect/lumenition, reductor or optical sensors (Crane and Piranha) and ECU. Features include adjustable dwell time, output or follow input option, tachometer output, adjustable debounce period, dwell compensation for battery voltage and coil switch-off with no trigger signal.

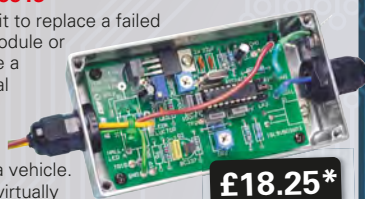

£18.25*

- Kit supplied with silk-screened PCB, diecast enclosure (111 x 60 x 30mm), pre-programmed PIC and PCB mount components for four trigger/pickup options

High Performance Timer Cat. KC-5379

This is a very sophisticated timer, which can be adapted for two different types of uses. The first is "one shot" operation, which can be used to keep electric windows active, or a thermo fan running for a period after ignition is switched off etc. The second is a pulse type operation, which can be used to squirt water spray for 1 second every 9 seconds. The uses are endless, and the time is adjustable from 0.1 seconds, to 16.5 minutes via easy to use (and accurate) digital switches. Kit supplied with PCB, and all electronic components.



£15.75*

- PCB: 105 x 60mm

Automotive Headlight Reminder Kit Cat. KC-5317

Features include a modulated alarm, ignition and lights monitoring, optional door switch detection, time-out alarm and a short delay before the alarm sounds. Kit includes quality solder masked PCB with overlay, case with screen printed lid and all electronic components.



£10.25*

- 12VDC
- PCB: 78 x 49 mm

Economy Adjustable Temperature Switch Kit Cat. KC-5381

If you don't need the display, or the huge operational range of the High Range Adjustable Temperature Switch with LCD, then this unit is a great alternative. It has an adjustable switching temperature up to 245°C, and it can be configured to trigger with rising or falling temperature. It has adjustable hysteresis (the difference between on/off temp) which is a great feature many other units do not possess.



£12.00*

- It can be used to operate cooling fans on a radiator or amplifier, over-temp warning lights or alarms, and much more. The small temperature sensor reacts quickly to temp changes.
- Kit supplied with PCB, NTC Thermistor, and all electronic components
- PCB: 105 x 60mm

Mixture Display Kits for Cars

Smart Fuel Mixture Display Kit for Fuel Injected Cars Cat. KC-5374

This improved model has an emergency lean-out alarm, better circuit protection and an auto dimming display. Another great feature is the 'dancing' display which operates when the ECU is operating in closed loop. Kit supplied with PCB and all electronic components.

- Car must be fitted with air flow and EGO sensors (standard on all EFI systems) for full functionality.
- PCB: 121 x 59mm

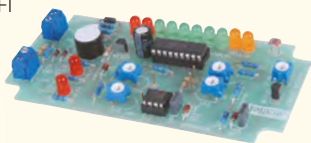

£11.00*

Mixture Display Kit for Fuel Injected Cars Cat. KC-5195

This very simple kit will allow you to monitor the fuel mixtures being run by your car. This type of sensor is also known as an E.G.O. (exhaust, gas, oxygen) monitor. The circuit connects to the EGO sensor mounted in the exhaust manifold and the cars battery. PCB, LEDs and components supplied.

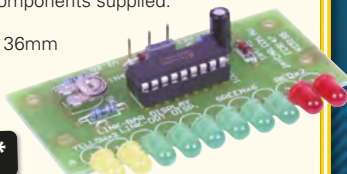

£6.25*

- PCB: 74 x 36mm



NOW SHIPPING VIA DHL
• FAST DELIVERY • TRACK SHIPMENT

5-10
working day
delivery

Post & Packing Charges

How to Order

Order Value	Cost	
£10	£49.99	£5
£50	£99.99	£10
£100	£199.99	£20
£200	£499.99	£30
£500+		£40

✓ We ship via DHL
 ✓ Expect 5-10 days for air parcel delivery
 ✓ Track & Trace parcel

Note: Products are despatched from Australia, so local customs duty & taxes may apply.

WEB: www.jaycar.co.uk
PHONE: 0800 032 7241*
FAX: +61 2 8832 3118*
EMAIL: techstore@jaycar.co.uk
POST: P.O. Box 107, Rydalmere NSW 2116 Australia

*Australian Eastern Standard Time (Monday - Friday 09.00 to 17.30 GMT + 10 hours)

All prices in Pounds Sterling. Prices valid until 31/03/2013

Voltage Monitor Kit Cat. KC-5424

This versatile kit will allow you to monitor the battery voltage, the airflow meter or oxygen sensor in your car. The kit features 10 LEDs that illuminate in response to the measured voltage, preset 9-16V, 0.-5V or 0-1V ranges. Complete with a fast response time, high input impedance and auto dimming for night time driving. Kit includes PCB with overlay, LED bar graph and electronic components.



£8.50*

- 12VDC
- PCB: 74 x 47 mm
- Recommended box: UB5 (use HB-6015 £1.25)

ORDER ONLINE: www.jaycar.co.uk

*All prices EXCLUDE postage & packing

Jaycar
Electronics

Better, More Technical

UK's No 1 source for VELLEMAN® Kits

Kit Catalogue Available

Self Assembly Kits & Ready made Modules - See our web site for details on the whole range, Data sheets, Software and more.

www.esr.co.uk

Now Available - Cebek Modules
All modules assembled & tested.

Digital Echo Chamber Kit
A compact sound effects kit, with built-in mic or line in, line out or speaker (500mW). 4 Adjustment controls. Power: 9Vdc 150mA



MK182 Velleman kit £11.43

3rd Brake Light Flasher Kit
Works with any incandescent or LED rear centre brake light. Flashes at 7Hz for 5 or 10 times, adjustable re-triggering. Power: 12Vdc max load 4A



MK178 Velleman kit £6.30

Digital Clock Mini Kit
Red 7 Segment display in attractive enclosure, automatic time base selection, battery back-up, 12 or 24Hr modes. Power: 9Vac or dc



MK151 Velleman kit £15.09

Proximity Card Reader Kit
A simple security kit with many applications. RFID technology activates a relay, either on/off or timed. Supplied with 2 cards, can be used with up to 25 cards. Power: 9Vac or dc



MK179 Velleman kit £14.25

Running Microbug Kit
Powered by two subminiature motors, this robot will run towards any light source. Novel shape PCB with LED eyes. Power: 2 x AAA Batteries



MK127 Velleman kit £9.02

200W Power Amplifier
A high quality audio power amp, 200W music power @ 4Ω 3-200kHz Available as a kit without heatsink or module including heatsink.
K8060 Velleman kit £12.85
Heatsink for kit £9.95
VM100 Module £38.54



Multifunction Up/Down Counter
An up or down counter via on-board button or ext input. Time display feature. Alarm count output. 0-9999 display. Power: 9-12Vdc 150mA



K8035 Velleman kit £17.85

Nixie Clock Kit
Gas filled nixie tubes with their distinctive orange glow. HH:MM display, automatic power sync 50/60Hz. Power: 9-12Vac 300mA



K8099 Velleman kit £64.96

Mini USB Interface Board
New from Velleman this little interface module with 15 inputs/outputs inc digital & analogue in, PWM outputs. USB Powered 50mA, Software supplied



VM167 Module £26.80

Thermostat Mini Kit
General purpose low cost thermostat kit. +5 to +30°C Easily modified temperature range/min/max/hysteresis 3A Relay. Power: 12Vdc 100mA



MK138 Velleman Kit £4.55

Velleman Function Generator
PC Based USB controlled function generator. 0.01Hz to 2Mhz Pre-defined & waveform editor. Software supplied. See web site for full feature list.



PCGU1000 Velleman £118.38

Digital Record/Player
Non volatile flash memory, Single 20 sec recording via integral mic, 2W output to 8Ω speaker. Power: 5Vdc 100mA



C-9701 Cebek Module £7.89

2 Digital Counter
Standard counter, 0 to 99 from input pulses or external signal. With reset input, 13.5mm Displays. Power: 12Vdc 90mA.



CD-9 Cebek Module £12.99

1.8W Mono Amplifier
Compact mono 1.8W RMS 4Ω power stage, short circuit & reverse polarity protection. 30-18kHz. Power: 4-14Vdc 150mA



E-1 Cebek Module £5.87

20W 2 Channel Amplifier
Mono amplifier with 2 channels (Low & High frequency), 20W RMS 4Ω per channel, adjustable high level. 22-22kHz, short circuit & reverse polarity protection. Power: 8-18Vdc 2A



E-14 Cebek Module £22.11

5W Stereo Amplifier
Stereo power stage with 5W RMS 4Ω, 30-18kHz, short circuit & reverse polarity protection. Power: 6-15Vdc 500mA



ES-2 Cebek Module £21.54

12Vdc Power Supply
Single rail regulated power supply complete with transformer. 130mA max, low ripple, 12Vdc with adjustment.



FE-103 Cebek Module £13.16

1-180 Second Timer
Universal timer with relay output. Time start upon power up or push button. LED indication. 5A Relay. Power: 12Vdc 60mA



I-1 Cebek Module £12.92

Cyclic Timer
Universal timer with relay output. Time start upon power up or push button. On & Off times 0.3-60 Seconds, LED indication. 5A Relay. Power: 12Vdc 80mA



I-10 Cebek Module £14.12

Light Detector
Adjustable light sensor operating a relay. Remote sensor & terminals for remote adjustment pot. 5A Relay. Power: 12Vdc 60mA



I-4 Cebek Module £13.98

Liquid Level Detector
A liquid level operated relay. Remote sensor operates relay when in contact with a liquid. 5A Relay. Power: 12Vdc 60mA



I-6 Cebek Module £13.08

Thermostat
A temperature controlled relay. Adjustable between -10 to 60°C Sensor on remote PCB. Connector for external adjustment pot. 5A Relay. Power: 12Vdc 60mA



I-8 Cebek Module £12.80

Start / Stop Relay
Simple push button control of a relay. Either 1 or 2 button operation. 5A Relay. Power: 12Vdc 60mA



I-9 Cebek Module £12.83

MP3 Player Kit
Plays MP3 files from an SD card, supports ID3 tag which can be displayed on optional LCD. Line & headphone output. Remote control add-on. Power: 12Vdc 100mA



K8095 Velleman kit £39.99

DC to Pulse width Modulator
A handy kit to accurately control DC motors etc. Overload & short circuit protection. Input voltage 2.5-35Vdc, Max output 6.5A. Power: 8-35Vdc



K8004 Velleman kit £9.95

Audio Analyser Kit
A small spectrum analyser with LCD. Suitable for use on 2, 4 or 8Ω systems. 300mW to 1200W(2x) 20-20kHz Panel mounting, back-lit display. Power: 12Vdc 75mA



K8098 Velleman kit £31.65

USB DMX Interface
512 DMX Channels controlled by PC via USB. Software & case included. Available as a kit or ready assembled module.



K8062 Velleman kit £47.90
VM116 Module £67.15

USB Interface Board
Featuring 5 in, 8 digital outputs, 2 in & 2 analogue outputs. Supplied with software. Available as a kit or ready assembled module.



K8055 Velleman kit £24.80
VM110 Module £34.90

8 Channel USB Relay Board
PC Controlled 16A relays with toggle, momentary or timed action. Test buttons included, available in a kit or assembled.



K8090 Velleman kit £39.95
VM8090 Module £58.40

RF Remote Control Transmitter
Single channel RF keyfob transmitter with over 13,122 combinations. Certified radio frequency 433.92MHz. Power: 12Vdc 2mA (inc) For use with TL-1,2,3,4 receivers.



TL-5 Cebek Module £14.64

RF Remote Control Receiver
Single channel RF receiver with relay output. Auto or manual code setup. Momentary output, 3A relay. Power: 12Vdc 60mA For use with TL-5 or TL-6 transmitters.



TL-1 Cebek Module £28.25

Keypad Access Control
An electronic lock with up to ten 4 digit codes. Momentary or timed (1-60sec/1-60min) output. Relay 5A. Power: 12Vdc 100mA Keypad included.



DA-03 Cebek Module £54.26

AC Motor Controller
A 230Vac 375W motor speed control unit giving 33 to 98% of full power. Power: 230Vac



R-8 Cebek Module £12.14

Components Hardware Soldering Switches Test Equipment Transformers Motors

PCB Equipment Connectors Power Supplies Enclosures Relays

Editorial Offices:

EVERYDAY PRACTICAL ELECTRONICS
 EDITORIAL Wimborne Publishing Ltd., 113 Lynwood
 Drive, Merley, Wimborne, Dorset, BH21 1UU
Phone: (01202) 880299. **Fax:** (01202) 843233.
Email: enquiries@wimborne.co.uk
Website: www.epemag.com

See notes on **Readers' Technical Enquiries** below
 – we regret technical enquiries cannot be answered
 over the telephone.

Advertisement Offices:

Everyday Practical Electronics Advertisements
 113 Lynwood Drive, Merley, Wimborne, Dorset,
 BH21 1UU
Phone: 01202 880299 **Fax:** 01202 843233
Email: stewart.kearn@wimborne.co.uk

Editor: MATT PULZER
Consulting Editor: DAVID BARRINGTON
Subscriptions: MARILYN GOLDBERG
General Manager: FAY KEARN
Graphic Design: RYAN HAWKINS
Editorial/Admin: (01202) 880299
**Advertising and
 Business Manager:** STEWART KEARN
 (01202) 880299
On-line Editor: ALAN WINSTANLEY

Publisher: MIKE KENWARD

READERS' TECHNICAL ENQUIRIES

Email: techdept@wimborne.co.uk

We are unable to offer any advice on the use, purchase,
 repair or modification of commercial equipment or the
 incorporation or modification of designs published
 in the magazine. We regret that we cannot provide
 data or answer queries on articles or projects that are
 more than five years' old. Letters requiring a personal
 reply must be accompanied by a stamped self-
 addressed envelope or a self-addressed envelope and
 international reply coupons. We are not able to answer
 technical queries on the phone.

PROJECTS AND CIRCUITS

All reasonable precautions are taken to ensure that
 the advice and data given to readers is reliable. We
 cannot, however, guarantee it and we cannot accept
 legal responsibility for it.

A number of projects and circuits published in
 EPE employ voltages that can be lethal. You should
 not build, test, modify or renovate any item of mains-
 powered equipment unless you fully understand the
 safety aspects involved and you use an RCD adaptor.

COMPONENT SUPPLIES

We do not supply electronic components or kits for
 building the projects featured, these can be supplied
 by advertisers.

We advise readers to check that all parts are still
 available before commencing any project in a back-
 dated issue.

ADVERTISEMENTS

Although the proprietors and staff of EVERYDAY
 PRACTICAL ELECTRONICS take reasonable
 precautions to protect the interests of readers by
 ensuring as far as practicable that advertisements are
 bona fide, the magazine and its publishers cannot give
 any undertakings in respect of statements or claims
 made by advertisers, whether these advertisements
 are printed as part of the magazine, or in inserts.

The Publishers regret that under no circumstances
 will the magazine accept liability for non-receipt of
 goods ordered, or for late delivery, or for faults in
 manufacture.

**TRANSMITTERS/BUGS/TELEPHONE
 EQUIPMENT**

We advise readers that certain items of radio
 transmitting and telephone equipment which may
 be advertised in our pages cannot be legally used in
 the UK. Readers should check the law before buying
 any transmitting or telephone equipment, as a fine,
 confiscation of equipment and/or imprisonment can
 result from illegal use or ownership. The laws vary from
 country to country; readers should check local laws.

EPE EVERYDAY PRACTICAL ELECTRONICS

Lightning, Daleks and accelerometers

It's a pleasure to welcome you to the March issue, which contains several projects I have been looking forward to for some time.

Our *Lightning Detector* is a clever AM-radio project that looks for electromagnetic signals with a tell-tale 'lightning signature'. It reminded me of an *Ingenuity Unlimited* submission, *Atmospheric Charge Monitor* – Aug '07 from our friend Thomas Scarborough. While this month's, and Thomas' designs, work on very different principles, they both demonstrate the power of electronics to detect and measure the world around us with relatively simple circuits. Perhaps even more importantly, they could be critical in saving you from a very nasty zap when out golfing, hiking or sailing!

Interplanetary Voice is one of those projects that is just plain fun. I'm certain it will be a sure-fire winner with younger constructors. If you are looking for a design to inspire and enthuse your children or perhaps students in a school electronics or technology club, then this could be the perfect choice. I just hope that too many parents or grown-ups don't live to regret supplying their young Daleks with a loud metallic voice – remember, it does have an off switch!

Great though these projects are, top of my list this month is the *Digital Spirit Level*. It's not that I have a large collection of sloping shelves and need to find a way to level them, but more about presenting you with a circuit that uses a 'micro electromechanical system' – or MEMS for short.

MEMS don't receive the recognition they undoubtedly deserve. They are essentially mechanical systems that have been miniaturised using microelectronic technology. The chip in the *Digital Spirit Level* is a clever three-axis accelerometer that costs less than the PCB, or project case. Before MEMS came along, accelerometers were expensive and relatively bulky devices that could easily cost hundreds of pounds each. Measuring three axes typically required three accelerometers and the resulting cost and size made them unsuitable for hobby electronics.

The accelerometer's close cousin – the gyroscope – has also been miniaturised as a MEMS, and they are at the heart of the control systems of all those cheap radio-control toy helicopters that fly with remarkable stability.

What accelerometers and gyroscopes do is allow a system to measure its own position, velocity and acceleration – both linear and in rotation – in three-dimensional space, a remarkable feat for such small, cheap devices.

I do hope we manage to provide more projects that use these fascinating devices, but in the meantime, do please have fun with our MEMS-based *Digital Spirit Level*.

Mick

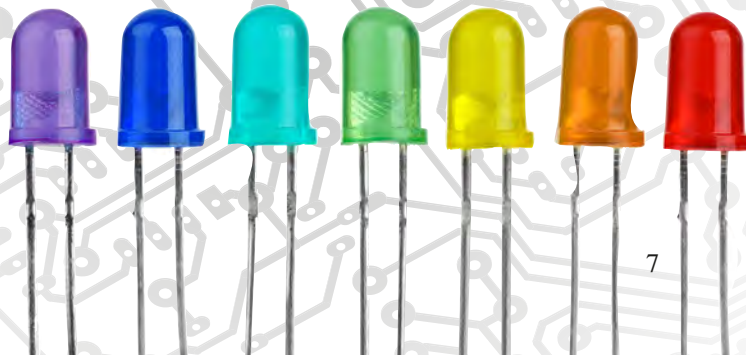

NEWS

A roundup of the latest Everyday News from the world of electronics



HDMI protection compromised – by Barry Fox

The music and movie companies are dead set on delivering entertainment online rather than on disc. The reasons for ‘going digital’ are obvious; no physical production costs, no warehousing, no delivery transport, no money to bricks-and-mortar middlemen and no returns. In pushing online delivery, the companies are assuming that ‘digital’ content is safe from easy home copying, thanks to the HDMI/HDCP connection system.

HDMI and protection

HDMI (High-Definition Multimedia Interface) is like a digital SCART connector; one lead carries pictures, sound, data and Ethernet connection. HDCP (High-bandwidth Digital Content Protection) encrypts the HDMI signal. The HDMI devices at each end of an HDMI cable handshake to confirm security against copying before allowing the signal to travel.

Analogue component (YPbPr) cables can also carry Hi-Definition video, but have no copy-protection. High quality digital audio travels by SP/DIF optical or coaxial cable, which also has no copy protection.

Several PVR (personal video recording) devices legitimately digitise and copy a Hi Def component

signal, and SP/DIF digital audio stream, to PC hard disk, eg, for capturing computer game play. US company Hauppauge sells a PVR box with USB connection for around £150. This is why Sky HD satellite boxes no longer have component connectors, and why the PS3 console disables its component output when playing movies.

Cheap strippers

For more than a year it has been easy to buy devices, eg, through Amazon, that strip out HDCP copy protection and convert an HDMI signal to an unprotected component signal. So a Hi-Def video signal can be captured like gameplay. The question is of course, how can such devices be sold?

The HDMI licensing organisation in the US refers enquiries on this to the HDCP licensing authority Digital-CP LLC, which is owned by silicon giant Intel.

A year ago, digital content protection administrator Caitlin Hier would say only: ‘We are unable to provide a response to your questions at this time.’

Now there are more HDCP-strippers on sale on Amazon, at ever-lower prices (some under £30). The cheaper ones cope with only 720p and 1080i signals, while the more

expensive versions handle 1080p full HD. The packaging is often generic. The devices need no set-up other than plugging between an HDMI output and component input.

HDMI Licensing LLP admits it is now ‘frustrated’ by an apparent lack of policing action by DCP LLC. An ‘HDMI Forum’, made up of many large companies, has taken on responsibility for the HDMI technical specification. Just as happened with the Blu-Ray Disc Association, but getting a room full of companies and their lawyers to decide anything is like trying to steer an oil tanker round a bend.

Stephen Balogh, of Intel, is President of DCP LLC. He says: “As a matter of policy...we don’t comment on every claim or instance of HDCP circumvention, nor do we publicly speculate on actions we may or may not be taking”.

I purchased and stripped down a £30 stripper. A neat and simple PCB, obviously mass-produced in a competent factory, with a mix of off-the-shelf and custom-designed, inscrutably and unclearly numbered chips.

- V1021
- ADV7393/BCPZ-3/#1203/2285920.1
- SILICON IMAGE VASTLANE/Si19025CTU/VL8709.1/0831/AE01MD2
- UC1ML7F/SA11178H—3.3
- UC1MGCD/SA11178H-1.8
- ATMEL135/24C02N/SU27 D
- 344C/1201

The HDMI organisation says it is investigating the chip list, which I supplied them for comment. *EPE* readers may in the meantime like to do their own investigations, and we would welcome letters and emails discussing this issue.

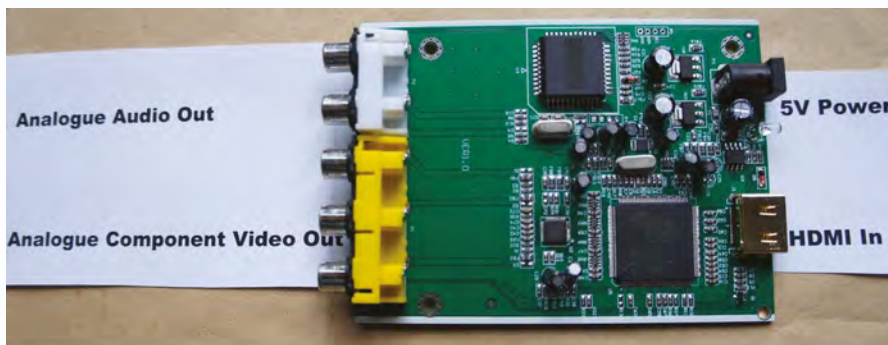

A cheap and easy-to-use HDCP copy-protection-stripping board, easily available from Amazon

Ultra-low power converter boosts energy harvesting

Texas Instruments has introduced the industry's lowest power DC/DC step-down converter, which increases the amount of harvested energy an end application can use by as much as 70% over alternatives. The resulting micro-power circuits allow battery-free power for mobile accessories and wireless sensors which use microwatts generated from solar, thermoelectric, magnetic and vibration energy. This enables applications, such as wireless networks, monitoring systems, smoke detectors, and wearable medical devices.

According to Sami Kiriaki, senior vice president of TI's Power Management, "TI continues to develop circuits with very low operating current and high power efficiency that can manage microwatts to milliwatts and extract ambient energy. This new power device gives designers capabilities not possible with traditional battery-powered systems."

The TPS62736 DC/DC converter delivers high power conversion efficiency from 10µA to 50mA output currents, and consumes only 350nA of active current and 20nA during standby. The converter achieves greater than 90% efficiency across output currents higher than 15µA. The regulator steps down the voltage from a power source, such as a thin-film or regular battery, or a super capacitor, and features a programmable output voltage.

The TPS62736 is the latest in a series of low-power devices from TI. In 2011, it introduced its bq25504 boost charger circuit with a low quiescent current of 330nA, to allow start-up from single-cell solar cells under low light, or thermoelectric generators with low temperature differences. More details about TI's low-power DC/DC converters is available at: www.ti.com/power-pr

Nanophotonics breakthrough

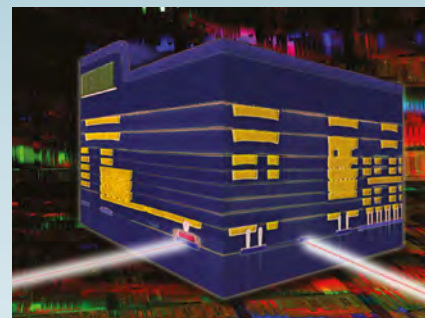

IBM 90nm silicon integrated nanophotonics technology is capable of integrating a photodetector (red feature on the left side of the cube) and modulator (blue feature on the right side) fabricated side-by-side with silicon transistors. Silicon nanophotonics circuits and silicon transistors are interconnected with nine levels of yellow metal wires.

IBM has announced a major advance in the ability to use light instead of electrical signals to transmit information for future computing. The breakthrough technology – called 'silicon nanophotonics' – allows the integration of different optical components side-by-side with electrical circuits on a single silicon chip using, for the first time, sub-100nm semiconductor technology.

Silicon nanophotonics takes advantage of pulses of light for communication and provides a super highway for large volumes of data to move at rapid speeds between computer chips in servers, large datacenters, and supercomputers, thus alleviating the limitations of congested data traffic and high-cost traditional interconnects.

"This technology breakthrough is a result of more than a decade of pioneering research at IBM," said Dr John Kelly, senior vice president and director of IBM Research. "This allows us to move silicon nanophotonics technology into a real-world manufacturing environment that will have impact across a range of applications."

COMMONER RARE EARTHS

From laser beams to exotic magnets, the 17 'Rare Earth' elements are a particularly useful, some would say strategically useful, ingredient in modern engineering recipes. Despite their name, they are not particularly rare, but mining them can be very environmentally hazardous. Now, almost the only country that extracts them (95% of world production) is China. The US has decided it does not wish to let China have near total control over such important minerals and has set aside \$120m to enable US mines to develop safe extraction techniques on US soil.

Ubuntu OS goes mobile



The Ubuntu operating system comes to Android smartphones

Canonical Ltd, the UK-based software company that created and distributes Ubuntu, a free, popular desktop Linux-based operating system (OS) has announced a smartphone interface for its OS.

Ubuntu is now compatible with a typical Android smartphone, which means it is ready to run on what they claim is 'the most cost-efficient chipset designs'. The objective in bringing Ubuntu to the phone is for users to have a single operating system for client, server and cloud, and a unified family of interfaces for the phone, the PC and the TV. "We are defining a new era of convergence in technology, with one unified operating system that underpins cloud computing, data centres, PCs and consumer electronics" says Mark Shuttleworth, founder of Ubuntu and vice president products at Canonical.

Over 20 million desktop PCs currently run the free OS, and Canonical estimates that close to 10% of the world's

new desktops and laptops will ship with Ubuntu in 2014. Ubuntu is also popular as a server platform, and the number one server OS on key major public clouds.

Both Ubuntu and Android run at the same time on the device, without emulation or virtualisation, and without the need to reboot. This is possible because both share the same kernel (Linux).

Unlike Apple's iOS system for iPhones, mobile Ubuntu is a full PC operating system. Canonical has stated that, 'It is able to offer a complete platform because phone CPUs can now run a complete desktop environment remarkably well'. For example, Ubuntu will run on low-end 2013 phones released with a dual-core Cortex A9 processor running at 1GHz, and with 512MB RAM. Modern processors in mobile phones often have multiple cores and Ubuntu apps are designed to use all available modern cores.

Ubuntu will include both the Chromium and Firefox browsers for easy and familiar web use.

Native app developers will be able to use Canonical's software development kit (SDK) for Ubuntu, which makes it easy to create apps that perform on a wide range of hardware and form factors.

More information is available at: www.ubuntu.com

This little device could save your life...

You don't want to be caught in a storm, especially if you are on a sports field, out boating, hill walking or working in the open, on the farm or anywhere else where there is minimum shelter. If there is even a risk of a storm, take this *Lightning Detector* with you before venturing outdoors.



Lightning Detector

By John Clarke

WHILE MOST of us love the wide open spaces, they are definitely not the place to be if a thunderstorm is on the way. If there is a lightning strike nearby you could be in big danger of death or injury. And you don't have to be hit directly – induction can kill you and so can the voltage gradient across the ground in the vicinity of a lightning strike.

Our *Lightning Detector* can warn you of an approaching lightning storm and provides valuable time to take shelter safely indoors. And even if you're not outdoors, it can give you warning to disconnect vulnerable electrical appliances from the 230VAC mains supply. It provides an audible and visual indication to warn of approaching thunderstorms.

Lightning damage to electronic appliances

Many people do not realise how vulnerable electronic equipment can be in a thunderstorm, even if it is not close by. Service organisations report a big surge in repair jobs

after storms, and just about all of this could be avoided simply by switching off and removing power plugs from the wall socket.

Those appliances especially at risk include microwave ovens, TV sets, satellite receivers, mains-powered computers (especially those also connected to the phone lines via a modem), washing machines and dryers.

They should not be just switched off at the power point; the mains plug should also be removed from the socket. TV antenna and satellite dish connections should be disconnected too. Many ovens incorporate electronic timers and power to these can be switched off at the 'fuse' box.

Apart from mains-powered computers, devices that are particularly prone to damage are fax machines and cordless telephone base stations. It is the fact that they are connected to both the 230VAC mains and the telephone wiring that provides a double whammy. During a big thunderstorm, they should be disconnected both from the phone line and the mains power.

Of course, it is well known that any phones (apart from mobiles and cordless models) should not be used during a thunderstorm.

So what to do?

To get a warning of imminent thunderstorms, you need our *Lightning Detector*. It is a pocket-sized unit that provides visual indication using a flashing LED and sounds an audible tone whenever lightning occurs in your area. The greater the number of lightning strikes, the more LED flashes and audible tone bursts are produced.

For portable use, it's powered by two alkaline AA cells and the battery life should be at least 1000 hours. For indoor use, you can use a 6V to 12V DC supply, such as a plugpack. One resistor needs to be chosen according to the DC supply voltage. When the external power supply is connected to the jack socket, the AA cells are automatically disconnected from the circuit.

The principle of operation is based on detection of the broad-spectrum electromagnetic emissions produced by lightning strikes. This is readily detected by a simple AM (amplitude modulation) radio receiver.

If you've ever been anywhere near an electrical storm with an AM radio turned on, you'll have heard the crashes (static) of lightning strikes. Very large strikes can be heard from a considerable distance away.

We use a single AM radio IC, which comprises an RF (radio frequency) amplifier, detector and AGC (automatic gain control). This was originally available in 1984 from Ferranti Semiconductors as the ZN414Z, but replaced by the MK484, now also obsolete.

We have used the modern equivalent, the TA7642. It operates from a 1.2V to 1.6V supply, and covers from 150kHz to 3MHz. This includes the normal AM radio broadcast band (530kHz to 1.6MHz), but for our purposes, we are not concerned with listening to broadcast radio stations. We simply monitor the whole spectrum covered by the AM radio chip.

Block diagram

The general arrangement of the *Lightning Detector* is shown in the block diagram of Fig.1. IC1 receives signals from a pickup coil. In an AM radio, this pickup coil would normally be tuned to a particular frequency using a variable tuning capacitor.

We want to monitor a wide frequency range, and so the coil is left untuned. IC1's output signal is noise bursts from lightning.

Output from IC1 is typically 15mV with a tuned coil, but is around 2mV with the untuned coil. This signal is amplified using transistor Q2 and a sensitivity control (VR1) sets the level applied to the following pulse extender,

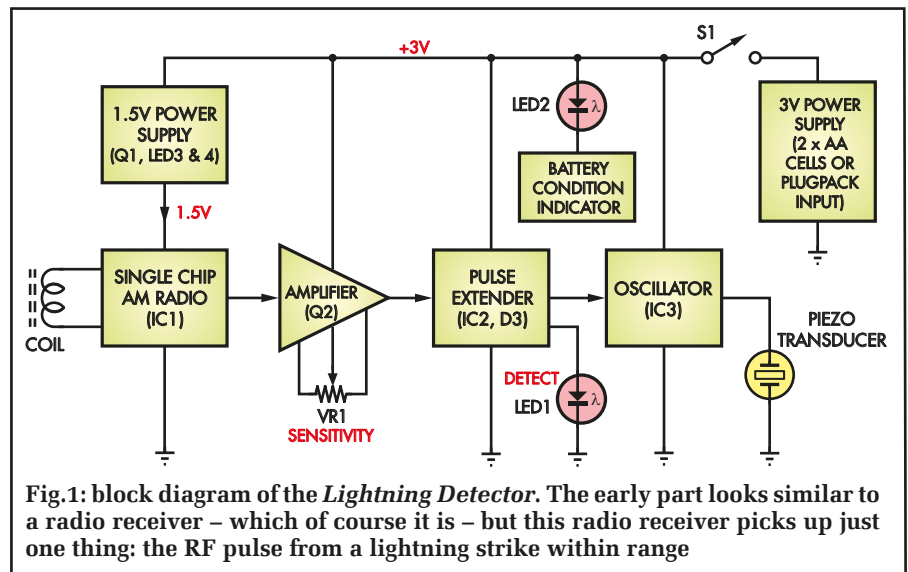

Fig.1: block diagram of the *Lightning Detector*. The early part looks similar to a radio receiver – which of course it is – but this radio receiver picks up just one thing: the RF pulse from a lightning strike within range

comprising IC2 and diode D3. When lightning is detected, a noise-burst triggers the pulse extender.

The pulse extender produces a 200ms pulse and this lights the 'detect' LED (LED1). The pulse extender is necessary because the lightning strike pulses are too short in duration to be noticed as a flash from the LED.

IC3 is an oscillator that runs for 200ms each time the pulse extender produces a low signal and the resulting 4kHz tone burst drives the piezo transducer, which is resonant at that frequency.

Circuit details

The full circuit is shown in Fig.2. As mentioned, IC1 is the TA7642 AM radio chip, while CMOS 555 timers are used for the pulse extender IC2 and for the 4kHz oscillator, IC3. The circuit is powered from 3V, but it will operate down to 2V.

A 1.5V regulated supply powers IC1, while the amplifier, pulse extender (IC2) and oscillator (IC3) are driven from the 3V supply.

While most of the circuit is powered from the 3V supply rail, IC1 needs to be operated at between 1.2V and 1.6V. To provide for this, we use a voltage regulator comprising Q1 and two infrared LEDs (LED3 and LED4). These develop a forward voltage of approximately 1V each, which is remarkably constant over a wide range of current. Tests of several infrared LEDs from different manufacturers showed that the forward voltage is around 1.09V at 1.6mA, dropping to 0.945V at 160µA, ie, a current range of 10:1.

Stacking two infrared LEDs in series provides a reasonably stable 2V reference. The LEDs are fed via a 2.2kΩ resistor from the 3V supply, and the 2V reference drives the base of transistor Q1. This acts as a current buffer to supply IC1 with about 1.4V. This varies from 1.46V with a 3V supply down to 1.287V with a 2V supply.

IC1 is connected to the 1.4V supply via the 470Ω AGC resistor

Features

- Portable
- Battery or external power supply
- Visual and audible lightning indication
- Sensitivity control
- Battery condition indicator
- Reverse supply protection

Constructional Project

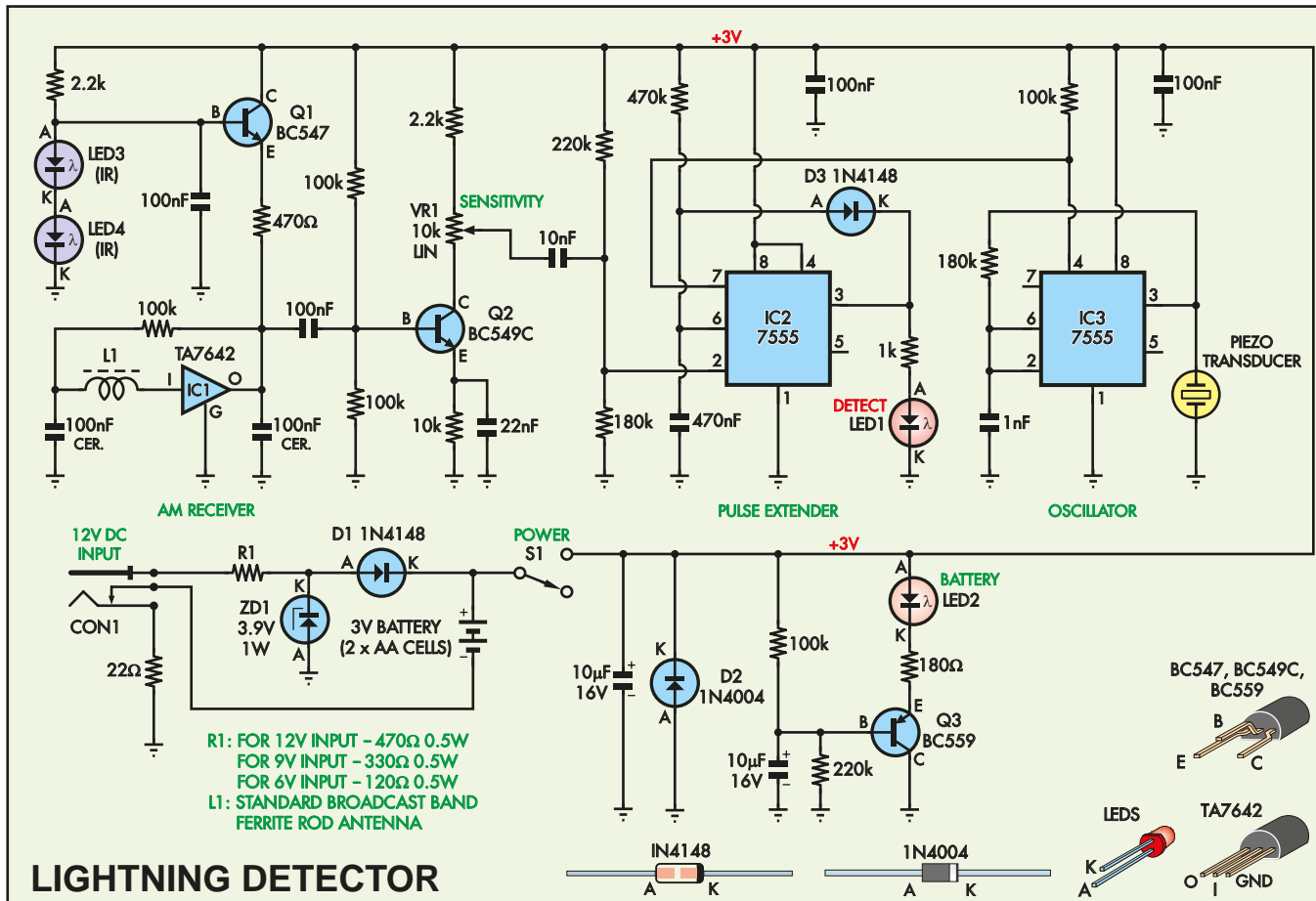

LIGHTNING DETECTOR

Fig.2: the three main functional areas of the circuit diagram are labelled the same as the block diagram to enable you to trace the circuit operation. As mentioned in the text, resistor R1 needs to be selected depending on the DC power supply you use – it can handle anything from 6-12V. The battery supply is nominally 3V, but it will operate down to 2V

at its output pin. A 100nF decoupling capacitor at the output sets the high-frequency rolloff to 4kHz.

One end of pickup coil L1 is connected to the high impedance (around 3MΩ) input of IC1, while the other end is grounded via a 100nF ceramic capacitor. There is no parallel capacitor across L1. This means that the coil is untuned and will have a broadband response. Bias for the input of IC1 comes from a 100kΩ resistor connected to its output.

IC1's output is AC-coupled to the following common-emitter amplifier, Q2. This has its emitter resistor bypassed with a 22nF capacitor to provide a gain of approximately 50 for frequencies above about 723Hz. Q2's collector load

comprises the 10kΩ potentiometer VR1 and a 2.2kΩ resistor. VR1 is the sensitivity control.

IC2 and IC3 are CMOS 555 timers, and most manufacturers of these devices state that their version will operate down to 2V or less. These include the Intersil ICM7555IPA, Texas Instruments TLC555CP, ST Microelectronics TS555CN and National Semiconductor LMC555CN. The NXP (founded by Philips) ICM7555CN guarantees operation at 3V over full automotive temperatures. However, performance graphs show operation with a 2V supply at -55°C, 25°C and 125°C. Also, samples of the NXP ICM7555CN operate successfully at 2V, and we are inclined to assume that this IC does also operate at 2V.

Specification

Supply voltage:	3V (2 × AA cells) – will operate down to 2V Pluggack, 6v to 12V DC at 30mA
Current consumption:	Battery operation is 1.5mA at 3V, 1mA at 2V, DC pluggack operation is 17mA at 12V
Battery life:	Typically 1000h with alkaline cells
IC1 supply:	Typically 1.46V with 3V supply, 1.28V with 2V supply
Battery voltage indication:	Down to 2V
Strike indication duration:	200ms
Transducer frequency drive:	4kHz
Frequency detection band:	150kHz to 3MHz

Make sure you do not use bipolar 555 timers such as, the LM555CN or the TL555CP; these typically require 4.5V or more for operation.

IC2 is the pulse extender, which is set up as a monostable timer. Before triggering occurs, pin 3 is close to 0V and the 470nF capacitor is held discharged at about 0.6V above 0V by diode D3. Pin 2 is held at 45% of the 3V supply, ie, at +1.35V, using the 220kΩ and 180kΩ voltage divider resistors.

Triggering occurs when the noise signal fed to pin 2 pulls it below +1V. This sets

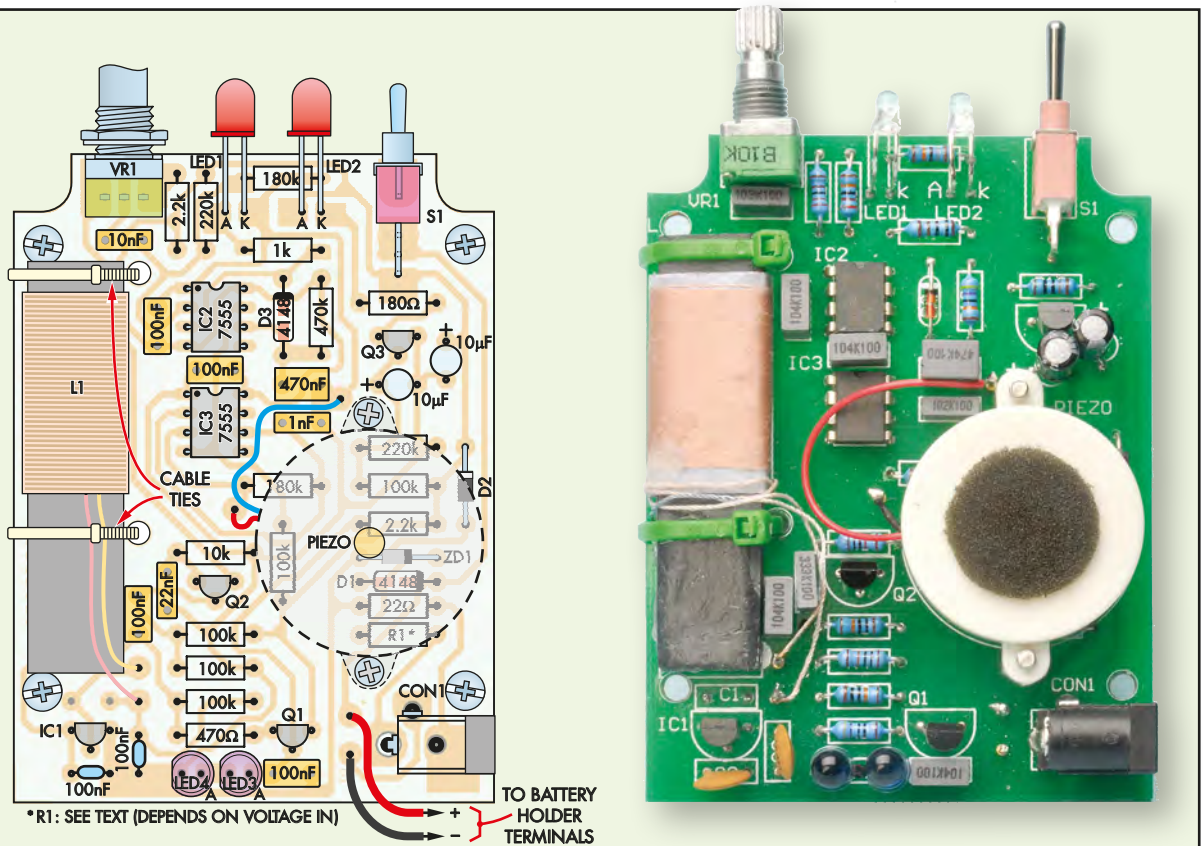

Fig.3: everything (except the batteries) mounts on a single-sided PCB. The component layout is shown above and, with the same-size photo at right, is self-explanatory. Fig.4 (right) is the drilling guide for the end panel. There is no labelling on this diagram; all controls are labelled on the front panel

End Panel Drill Guide

+	+	+	+
Switch 5mm	LED 3mm	LED 3mm	Pot 7mm

pin 3 high and diode D3 is then reverse biased. The 470nF capacitor then begins to charge via the 470kΩ resistor. During this time, LED1 is lit (driven from pin 3). When the voltage across the 470nF capacitor reaches 2/3 of the supply voltage, pin 3 goes low and the 470nF capacitor is discharged via diode D3.

This is an unconventional monostable timer arrangement. Normally, pin 7, the discharge, would be connected to pin 6 and would discharge the 470nF capacitor instead of using diode D3. Using D3 to discharge the capacitor frees pin 7 to perform another task. Because it can sink (pull down) to 0V, it is suitable for use as a reset control for the following oscillator, IC3.

IC3 is connected in astable (free-running) mode, running at about 4kHz to drive the piezo transducer. It is held in the reset condition, with its pin 4 pulled low by pin 7 (discharge) of IC2, when IC2 is not timing.

Power supply

As already mentioned, the *Lightning Detector* is powered from two AA-cells or a low voltage plugpack supply. When running from the AA cells, current flows via the closed contact in the power connector (CON1) and through the 22Ω resistor to the 0V supply. This resistor is included to prevent excess current if the cells are inserted back-to-front. When the cells are correctly inserted, the 22Ω resistor produces

a minimal voltage drop (normally less than 33mV and less than 100mV with the detect LED lit).

When running from a DC supply, the AA cells are disconnected via CON1 (as noted earlier) and the incoming supply is regulated down to 3.9V using Zener diode ZD1 and resistor R1. The value of this resistor depends on the DC supply voltage – anywhere from 6V to 12V will be suitable, with resistor values of 120Ω (6V), 330Ω (9V) or 470Ω (12V). The negative supply connects to the circuit ground via the 22Ω resistor.

Diode D1 reduces the 3.9V Zener voltage supply to about 3.3V. We could have used a 3.3V Zener diode on its own without D1. However, we want to be able to run the circuit from two AA cells that provide a 3V supply. If a 3.3V Zener diode were used, the cells would be discharged via the Zener diode. So, by including diode D1, current is prevented from flowing through the Zener diode. The Zener voltage is increased from 3.3V to 3.9V to compensate for the 0.6V diode drop.

D1 also blocks reverse voltage to the circuit should the 12V supply be connected with reversed polarity. With reverse polarity, Zener diode ZD1 is forward biased and clamps the voltage to no more than -0.6V below the 0V supply. D1 stops current flowing through the circuit backwards.

Battery indication

When the power is first switched on, LED2 provides indication of the battery condition. LED2 is driven via PNP

Parts List – Lightning Detector

- 1 PCB, code 888, 65mm × 86mm
- 1 remote control case, 135mm × 70mm × 24mm
- 1 panel label, 50mm × 114mm
- 1 miniature PC-mount SPDT toggle switch (Altronics S1421 or equivalent) (S1)
- 1 knob to suit potentiometer
- 1 switched 2.5mm PCB mount DC socket (CON1)
- 2 AA alkaline cells
- 2 8-pin IC sockets (optional)
- 1 tuning coil with ferrite rod (Jaycar LF-1020 or similar)
- 1 low-profile piezo transducer
- 2 6mm spacers
- 2 M2.5 × 12mm screws
- 4 6mm self-tapping screws
- 2 100mm cable ties
- 6 PC stakes
- 1 50mm length of red light gauge hookup wire
- 1 50mm length of black light gauge hookup wire

Semiconductors

- 1 TA7642 single chip AM radio (IC1) (www.conrad-uk.com or eBay)
- 2 7555 CMOS 555 timers (ICM75551PA, TLC555CP, TS555CN, LMC555CN or ICM7555CN) (IC2, IC3)
- 2 3mm high intensity red LEDs (LED1, LED2)
- 2 5mm IR LEDs (LED3, LED4)
- 1 BC547 NPN transistor (Q1)
- 1 BC549C NPN transistor (Q2)
- 1 BC559 PNP transistor (Q3)
- 1 3.9V 1W Zener diode (ZD1)
- 2 1N4148 signal diodes (D1, D3)
- 1 1N4004 rectifier diode (D2)

Capacitors

- 2 10µF 16V PC electrolytic
- 1 470nF MKT polyester
- 4 100nF MKT polyester
- 2 100nF ceramic
- 1 22nF MKT polyester
- 1 10nF MKT polyester
- 1 1nF MKT polyester

Reproduced by arrangement
with SILICON CHIP
magazine 2013.
www.siliconchip.com.au

Resistors (0.25W, 1%)

- | | | | | |
|---------|---------|---------|---------|--------|
| 1 470kΩ | 2 220kΩ | 2 180kΩ | 5 100kΩ | 1 10kΩ |
| 2 2.2kΩ | 1 1kΩ | 1 470Ω | 1 180Ω | 1 22Ω |
- 1 of 120Ω, 330Ω or 470Ω 0.5W (R1 – see text)

- 1 10kΩ log potentiometer, 9mm square, PCB-mount

transistor Q3 and its base (B) is initially tied to 0V via the 10µF capacitor. With the supply at 3V, Q3's emitter is at about 0.6V and the LED is driven at maximum brightness. That is with about 2.4V (3V – 0.6V) across the LED and 180Ω resistor. Assuming an LED forward voltage of 1.8V, this produces a current of about 3mA.

At a lower supply voltage, the initial LED current is less and it will be dimmer. With a 2V supply, LED2 will be barely alight, indicating that the batteries should be replaced.

Whatever the supply, LED2 only lights momentarily and as the 10µF capacitor begins to charge via the 100kΩ

Here's how the PCB fits inside the case. The top corners need to be shaped to fit the case mounting pillars, but otherwise it's a simple drop-in fit, secured by four self-tapping screws. The two AA batteries which power the unit fit under the moulding at the bottom

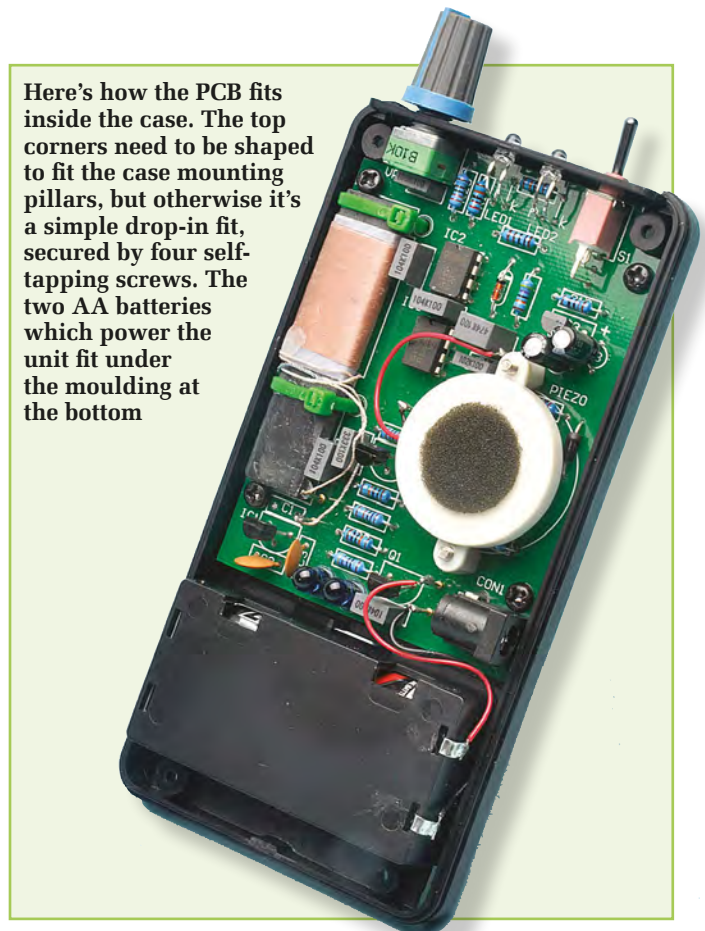

resistor, it dims and eventually goes out. The 220kΩ resistor across the 10µF capacitor prevents the capacitor charging to any more than 2/3rds the supply. This provides a faster discharge of the capacitor when the supply is switched off. The 220Ω resistor is also used to discharge the capacitor when the supply is off, so it is ready to flash the LED when power is reapplied.

Construction

The *Lightning Detector* uses a PCB measuring 65mm × 86mm and is coded 888. This board is available from the *EPE PCB Service*. The topside component layout is shown in Fig.3. The PCB and components are housed in a plastic case measuring 135mm × 70mm × 24mm.

The PCB is designed to mount on to the integral mounting bushes within the box. Make sure the front edge of the board is shaped to the correct outline so it fits properly. It can be filed to shape if necessary, using the PCB outline shape as a guide.

Begin construction by checking the PCB for breaks in tracks or shorts between tracks or pads. Fix any defects, if necessary. Check the hole sizes for the PCB mounting holes and for the cable ties. These are 3mm in diameter.

You can then insert the resistors. Use the resistor colour code table to select each value or, better still, check each one with a digital multimeter. Then install the diodes; they must be mounted with the orientation shown. Install the six PC stakes.

IC2 and IC3 can be mounted on sockets or directly soldered to the PCB. When installing sockets and ICs, take care to orient them correctly – as indicated by the notch at one end – see Fig.3.

The capacitors can be mounted next. The electrolytic types must be oriented with the shown polarity. Make sure these capacitors are placed on the PCB so their height above the surface is no more than 12.5mm; otherwise, the lid of the case will not fit correctly.

Note that while provision is made for a capacitor across coil L1, one is not used in this circuit (as mentioned earlier). It is included so that you can experiment with the radio IC by placing a tuning capacitor between the two PC stakes for coil L1 and placing a fixed-value (if required) capacitor to pad out the capacitor range. This will allow the reception of radio broadcast stations.

The audio signal will be available at VR1's wiper. A coupling capacitor (say 100nF or so) is required to connect this signal to an external amplifier.

Now mount IC1 and the transistors, taking care to place each in its correct place. If you happen to be using a Ferranti ZN414Z from your IC collection for IC1, note that the GND and OUT pins are reversed compared to the specified TA7642. You would also have to place the IC in the PCB oriented 180° to that shown on the overlay.

An MK484 has the same pinout as the TA7642. The TA7642 has a greater sensitivity in the lightning detector application compared to the MK484 and so given the choice, we recommend using the TA7642. We did not try a ZN414Z, since this is no longer available.

The potentiometer (VR1) and PCB-mounted switch S1 can now be soldered in.

LED1 and LED2 are next. These mount horizontally, but at a height of 6mm above the board surface. Bend their leads 90° at 7mm back from the base of the LEDs, making sure the anode (A) lead is to the left.

Detector coil

L1 is a standard broadcast band coil pre-wound on to a small ferrite rod. There are actually two coils on the rod, but only one is used.

Using your multimeter, find the coil that has the greatest resistance. With our prototype, the main winding measured about 11Ω, while the separate antenna winding measured 2Ω. Connect the coil with the highest resistance to the PC stakes. The ferrite rod is secured to the PCB using a pair of small cable ties.

The piezo transducer is mounted using two 6mm-long standoffs and M2.5 × 12mm screws. The screws are inserted from the underside of the PCB, pass through the spacers and tap into the piezo mounting tabs. If you are using a different piezo transducer that has larger mounting holes in the tabs, M3 screws could be used instead to tap into the plastic transducer tabs. Alternatively, two nuts can be used.

Follow the wiring diagram to make the connections from the piezo transducer and battery terminals to the PC stakes on the PCB.



This end-on view shows the two controls and two LEDs which mount on the end panel

Next, install the battery clips into the battery compartment. The two connected terminals are placed on the right-hand side (as you look at the rear of the case with the compartment at the bottom). The spring terminal is placed to the top and the raised section to the bottom. For the left side, insert the separate terminals with the spring terminal placed at the lower edge and the raised section to the top.

The next step is to bend the two individual terminals to the outside of the compartment. You may need to stretch the contact springs so that the AA cells are held securely between the contacts.

The PCB is secured to the base of the case using four M3 × 6mm screws that screw into the integral mounting bushes in the box. Before fitting them in place, drill out the small front panel for the LEDs, potentiometer and switch. Fig.4 shows the drilling template and this can be copied and attached to the panel during drilling.

The panel label for this project can either be photocopied (see Fig.5) or for best results, it can be downloaded from the EPE website (www.epemag.com).

When downloaded, print it on to paper, sticky-backed photo paper or plastic film. For protection and long life, paper labels should be covered with either self-adhesive clear film or (as we normally do) hot laminate it (laminators and sleeves are very cheap these days and give a tough protective layer!).

If printing on clear plastic film (overhead projector film) you can print the label as a mirror image, so that the ink is behind the film when placed on to the panel. Again, this will give the label maximum protection. Once the ink is dry, cut the label to size.

The paper or plastic film is glued to the panel using an even smear of neutral-cure silicone. For plastic film, if you are gluing it to a black-coloured panel, use coloured silicone such as grey or white, so the label can be seen against the black.

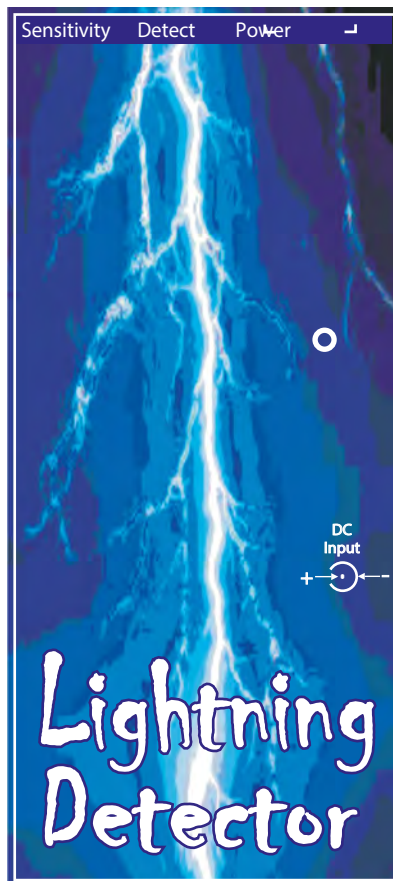

Fig.5: this same-size panel artwork can be photocopied or downloaded and printed, then glued in place

RESISTOR COLOUR CODES

No.	Value	4-Band Code (1%)	5-Band Code (1%)
<input type="checkbox"/>	1 470k Ω	yellow purple yellow brown	yellow purple black orange brown
<input type="checkbox"/>	2 220k Ω	red red yellow brown	red red black orange brown
<input type="checkbox"/>	2 180k Ω	brown grey yellow brown	brown grey black orange brown
<input type="checkbox"/>	5 100k Ω	brown black yellow brown	brown black black orange brown
<input type="checkbox"/>	1 10k Ω	brown black orange brown	brown black black red brown
<input type="checkbox"/>	2 2.2k Ω	red red red brown	red red black brown brown
<input type="checkbox"/>	1 1k Ω	brown black red brown	brown black black brown brown
<input type="checkbox"/>	1 470 Ω	yellow purple brown brown	yellow purple black black brown
<input type="checkbox"/>	1 180 Ω	brown grey brown brown	brown grey black black brown
<input type="checkbox"/>	2 22 Ω	red red black brown	red red black gold brown
<i>One of the following (R1):</i>			
<input type="checkbox"/>	1 470 Ω	yellow purple brown brown	yellow purple black black brown
<input type="checkbox"/>	1 330 Ω	orange orange brown brown	orange orange black black brown
<input type="checkbox"/>	1 120 Ω	brown red brown brown	brown red black black brown

A hole in the panel is required directly above the piezo transducer. This can be first drilled in the plastic lid and then once the panel label is affixed, cut the hole out using a sharp hobby knife.

A small piece of dark fabric or loudspeaker foam (scrounged from an old pair of headphones) can be used to cover the piezo transducer. Also, a black bezel over the panel hole can improve the finish of the unit. These are secured with a smear of neutral cure silicone. Our bezel came from the plastic dress plate that sits behind the nut of a stereo 6.35mm jack socket.

Additionally, a cut out is required for access to the DC socket. A rat-tail file can be used to make this hole in the lid.

Testing

Testing can be done with two AA cells or a DC supply. Apply power and check that the power LED momentarily lights when the *Lightning Detector* is switched on. Check the supply voltage by measuring across diode D2. This should be around 3V, but may differ depending on the state of the cells or the tolerance of the 3.9V Zener diode when a DC power supply is used. The voltage across the 22 Ω resistor should be about 33mV with a 3V supply, or less with a lower voltage supply.

Check the supply to IC1 at the emitter of Q1. This should be 1.46V with a 3V supply, dropping to 1.287V with a 2V supply.

Adjust the sensitivity control fully clockwise or back off if any indication persists.

You can now test the *Lightning Detector* as a fluorescent light is switched on. Conventional fluorescent tubes will cause the *Lightning Detector* to give an LED detect and tone indication as each starter attempts to light its tube. By contrast, compact fluorescent tubes tend to be indicated with a single flash and tone as the tube lights rapidly.

The sensitivity control is included to prevent the *Lightning Detector* from producing an indication when there is no lightning. The control is adjusted clockwise for maximum sensitivity to lightning, but not so far as to give false detection.

EPE

What to do in a storm

The best idea is to avoid getting caught outside in an electrical storm, but sometimes, the best laid plans of mice and men . . . etc.

How far away is the lightning?

Watch for a flash of lightning. Then count or read off your watch the number of seconds until you hear the first crash of thunder (or crack if it is close!). Divide the number of seconds by three and you have a rough distance to where the lightning has struck. Anything less than 1km (ie, 3s) should be regarded as getting very dangerous.

If you cannot get to shelter?

If you are caught outside during an electrical storm, avoid conductors of electricity such as water, trees, poles, golf clubs, umbrellas and metal fences.

If possible, keep away from open spaces (eg, the middle of a sports field) where you will be taller than the surroundings and definitely do not shelter under a tree. Crouch down, keeping your feet close together and wait out the storm. Groups of people should be spread out several metres apart.

It is also a good idea to cover your ears with your hands to avoid hearing damage due to the noise of a close lightning strike.

If possible, take refuge inside a vehicle or building. If inside a vehicle, close the windows and avoid touching the metal of the vehicle. Make yourself less of a target by lying down (eg, on the back seat). Keep the vehicle away from trees or tall objects that may fall over in the storm. Avoid fallen power lines.

Inside a building, keep windows and doors closed and keep away from windows, doors and fireplaces. Before the storm, unplug electrical appliances that may be susceptible to lightning damage. These include fax machines, telephones, microwave ovens, televisions and computers. To be doubly safe, unplug any computer communications devices from phone lines or cables (don't forget routers).

Avoid using electrical appliances and telephones until the storm has well and truly passed. However, you can use a mobile phone if you have to, eg, to call for help.

Avoid touching earthed fittings, such as water taps, sinks, appliances and so on.

If you are on a boat, keep low, dry and away from metal conductors. Always check with the Met Office for storm forecasts before going out on a boat. In this way, you could avoid boating in a storm. If you are a boat owner, make sure the boat is fitted with lightning protection that directs lightning safely to the water. This will help protect the occupants should they be caught out in a storm and also help protect the boat when left moored.

If someone near you is struck by lightning?

Avoid the temptation to rush in and help – time is of the essence, but there's no point in two people being struck!

As soon as it is safe to do so (ie, the danger has passed), commence standard A-B-C resuscitation. Check their response, clear the airway, and if necessary proceed with CPR.

What? You don't know CPR? Learn it today!

EPE
EXCLUSIVE

Win a Microchip XLP 8-Bit Development Board

EVERYDAY PRACTICAL ELECTRONICS is offering its readers the chance to win a **Microchip XLP 8-Bit Development Board (DM240313)**. The XLP 8-bit Development Board provides a low-cost, highly configurable, development system for Microchip's new line of extreme-low-power 8-bit PIC18F or PIC16F enhanced core microcontrollers that allow for design of sleep currents down to 20nA. The board supports development for the PIC18F87K22 or PIC16LF1947 MCUs, which highlight the capabilities of each product family.

The board can be powered by five different power sources, including batteries or energy harvesting modules (sold separately), and it supports a variety of common components that can be selective enabled. The board is also expandable through the on-board PICtail connector that permits the addition of capabilities such as RF connectivity. The kit includes a USB cable, a power measurement cable, a *Quick Start guide* and a PIC16LF1947 PIM.

The board is suitable for prototyping many low-power applications, including RF, temperature sensors, electronic door locks, LCD, remote controls, security sensors, smart cards, and energy harvesting. The PICtail interface supports Microchip's extensive line of daughter cards for easy evaluation of your next low-power application.

WORTH
\$125.00
(approx. £78.00)
EACH

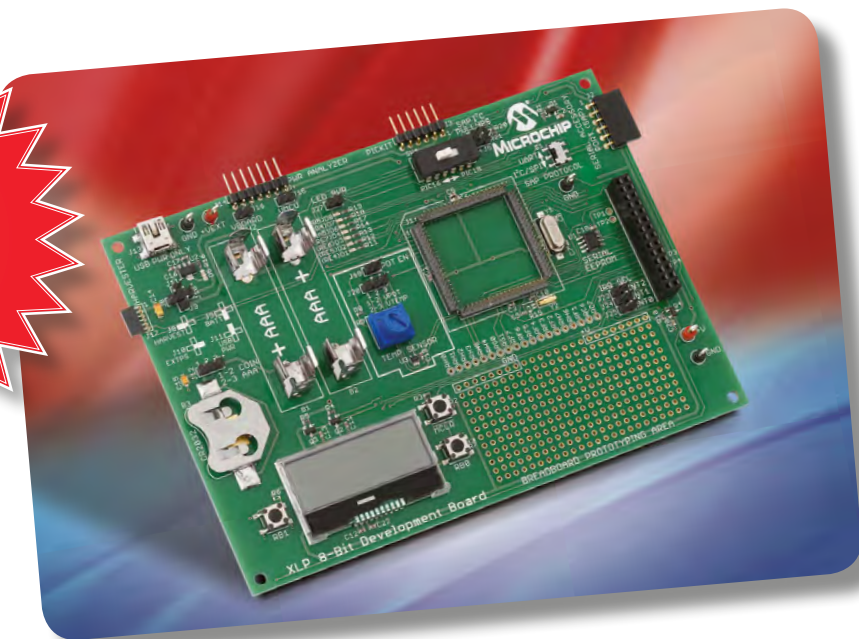

HOW TO ENTER

For your chance to win the *XLP 8-Bit Development Board* from Microchip, please visit: www.microchip-comps.com/epe-xlp8, and enter your details in the online entry form.

CLOSING DATE

The closing date for this offer is 31 March 2013



Part 2: By JIM ROWE

Check all those semiconductors in your collection with this easy-to-build test set!

This month, we present the full circuit of this versatile unit, which can test all the discrete semiconductors in your collection. It employs a PIC16F877A microcontroller to run all the different tests, and displays the results on a 2-line LCD panel.

THERE'S quite a lot of circuitry in the new *SemTest*, despite the fact that most of its operation is managed by a microcontroller. For that reason, the circuitry is accommodated on two PCBs, which are stacked inside the case.

To begin the circuit description we will start with the lower or main PCB, which carries the micro, the power supplies and metering. This section of the circuit is shown in Fig.5.

Microcontroller IC4 forms the brain of the *SemTest*. We have used a

PIC16F877A because it has five I/O ports, including three that are eight bits wide. It also includes a 10-bit ADC (analogue-to-digital converter) with a choice of eight input channels.

All eight bits of both ports B and D are used to control the various relays which provide the test configurations. The two ports drive IC5 and IC6, which are ULN2803A octal Darlington arrays, which in turn drive a total of 16 relays.

Most of these are on the upper PCB, but four relays are on the main board:

- Relay 1, which is used to switch the device test voltage on and off
- Relay 2, which switches the test voltage between its 'BV' or 'OPV' modes
- Relay 7, which controls the value of the current shunt resistor used to measure device current (and hence switch current ranges)
- Relay 8, which controls the voltage divider ratio for device voltage measurement (ie, to switch voltage measurement ranges).

Connections to the relays on the upper PCB are made via CON3 and CON4.

Bit lines RC0 to RC3 of port C, together with RE0 and RE1 of port E, are used to control the LCD module, which is again on the upper PCB. These connections are made via CON2, which links to CON5 on the upper board via a 10-way IDC ribbon cable.

The remaining bit lines, RC4 to RC7 of port C, plus bit line RE2 of port E are used to monitor activity on the five pushbutton switches S3 to S7. These mount on the instrument's front panel and are connected using a 16-way IDC ribbon cable from CON7 on the upper PCB to CON4 on the main board.

The same connectors and cable are used to make the connections for relays 3 to 6, 9, 15 and 16, plus the connection for LED1 (the 'Test Volts Present' indicator).

High-voltage supply

The test voltage power supply circuitry at upper left on Fig.5 has been adapted from the high-voltage power supply in the *Electrolytic Capacitor Tester/Reformer* described in August-September 2012.

As before, the supply is a step-up DC-DC converter using IC1 (an MC34063) as the controller, with transistors Q1 and Q2 used to drive MOSFET Q3 and transformer T1. The 'flyback' voltage pulses developed by T1 are rectified by fast diode D2 and fed to the output filtering and current-limiting circuitry. The MC34063 maintains the output voltage at the selected level by means of negative feedback from the four 75k Ω resistors in series with trimpot VR1 in the top leg, plus the 100k Ω resistor connected from pin 5 of IC1 to ground as the 'default' bottom leg.

This basic divider determines the converter's nominal '10V' output level.

The three other operating test voltages (25V, 50V and 100V) are achieved using switch S2a to bring other resistances in parallel with the 100k Ω lower resistor, while relay 2(a) is used to achieve the converter's much higher (about 600V) 'BV' output voltage by switching in a 680 Ω resistor across the 100k Ω resistor instead.

Trimpot VR1 is used to set the converter's OPV output voltages precisely. Bit lines RA4 and RA5 of the micro's port A are used to sense the setting of switch S2, ie, via poles S2b and S2c.

Features and Specifications

Main Features

A compact yet flexible test set for most common discrete semiconductor devices, including diodes (junction and Schottky), LEDs, Zeners, diacs, bipolar junction transistors (BJTs), MOSFETs, SCRs and thyristors (including triacs). Based on a PIC16F877A microcontroller, with device and test selection, plus the test results displayed via a 16x2 alphanumeric LCD readout. Devices to be tested are connected to the test set via an 18-way ZIF socket.

Five test voltages are available: a 600V source for avalanche breakdown (BV) testing, plus a choice of either 10V, 25V, 50V or 100V for operating voltage (OPV) tests. All test voltages are applied to the DUT via current-limiting resistors – 100k Ω in the case of BV tests or 2k Ω in the case of OPV tests.

Maximum avalanche current which can flow during BV tests is 6mA (short circuit current).

Maximum device/leakage current which can flow with OPV = 100V is 30mA; with OPV = 50V is 25mA; with OPV = 25V is 12.5mA; and with OPV = 10V is 6mA.

Minimum leakage current which can be measured = 1 μ A.

Diode tests

- (1) Reverse avalanche current I_R (BV)
- (2) Reverse leakage current I_R (OPV)
- (3) Forward voltage drop V_F (OPV)
- (4) Zener/avalanche voltage V_R (BV)

Reproduced by arrangement
with SILICON CHIP
magazine 2013.
www.siliconchip.com.au

LED tests

- (1) Reverse leakage current I_R (OPV = 10V)
- (2) Forward voltage drop V_F (OPV)

BJT tests

- (1) Breakdown voltage C-B with emitter o/c $V_{(BR)CBO}$
- (2) Breakdown voltage C-E with base o/c $V_{(BR)CEO}$
- (3) Leakage current C-B with emitter o/c I_{CBO} (OPV)
- (4) Leakage current C-E with base o/c I_{CEO} (OPV)
- (5) Forward current gain h_{FE} with a choice of three base current levels: 20 μ A, 100 μ A or 500 μ A
 - Maximum h_{FE} which can be measured with $I_B = 20\mu A$ is 1500 (OPV = 100V)
 - Maximum h_{FE} which can be measured with $I_B = 100\mu A$ is 300 (OPV = 100V)
 - Maximum h_{FE} which can be measured with $I_B = 500\mu A$ is 60 (OPV = 100V)

MOSFET tests

- (1) Breakdown voltage D-S with G-S shorted $V_{(BR)DSS}$
- (2) Leakage current D-S with G-S shorted I_{DSS} (OPV)
- (3) D-S current I_{DS} versus G-S bias voltage V_{GS} (ie, gm)

SCR, PUT and triac tests

- (1) Breakdown voltage with G-K (SCR) or G-A (PUT) shorted $V_{(BR)AKS}$
- (2) Leakage current with G-K (SCR) or G-A (PUT) shorted I_{AKS} (OPV)
- (3) Current I_{AKS} with gate current applied (20 μ A, 100 μ A or 500 μ A) and OPV .. applied
- (4) Voltage drop A-K when conducting V_{AK} (OPV)

Note: the test set operates from an external power source of 12V DC. Current drain varies from around 65mA when a test is being set up, to a maximum of approximately 900mA during testing. It can, therefore, be powered from either a 12V SLA battery or a 12V/1A mains power supply or regulated DC plugpack.

Constructional Project

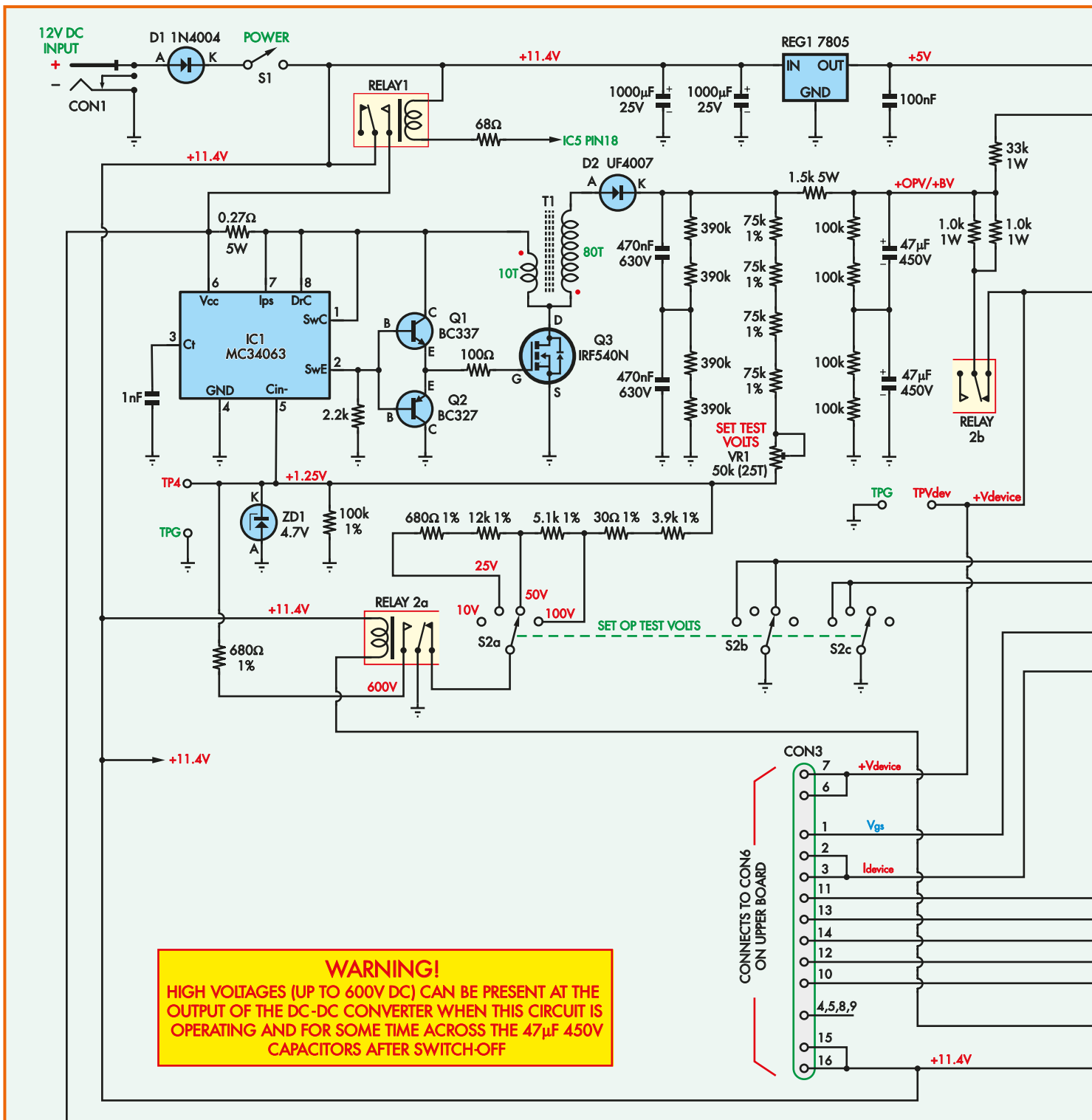

SEMTEST DISCRETE SEMICONDUCTOR TEST SET MAIN CIRCUIT (LOWER BOARD)

Fig.5: the main part of the *SemTest* circuit is built on the lower PCB and includes microcontroller IC4, the power supplies and metering. IC4 controls the relays via IC5 and IC6; performs A-D conversion of the measurements applied to its inputs and drives the LCD on the upper board via CON2. The test voltages (up to 600V) are generated by a DC-DC converter circuit based on IC1, transformer T1 and MOSFET Q3 at upper left

Constructional Project

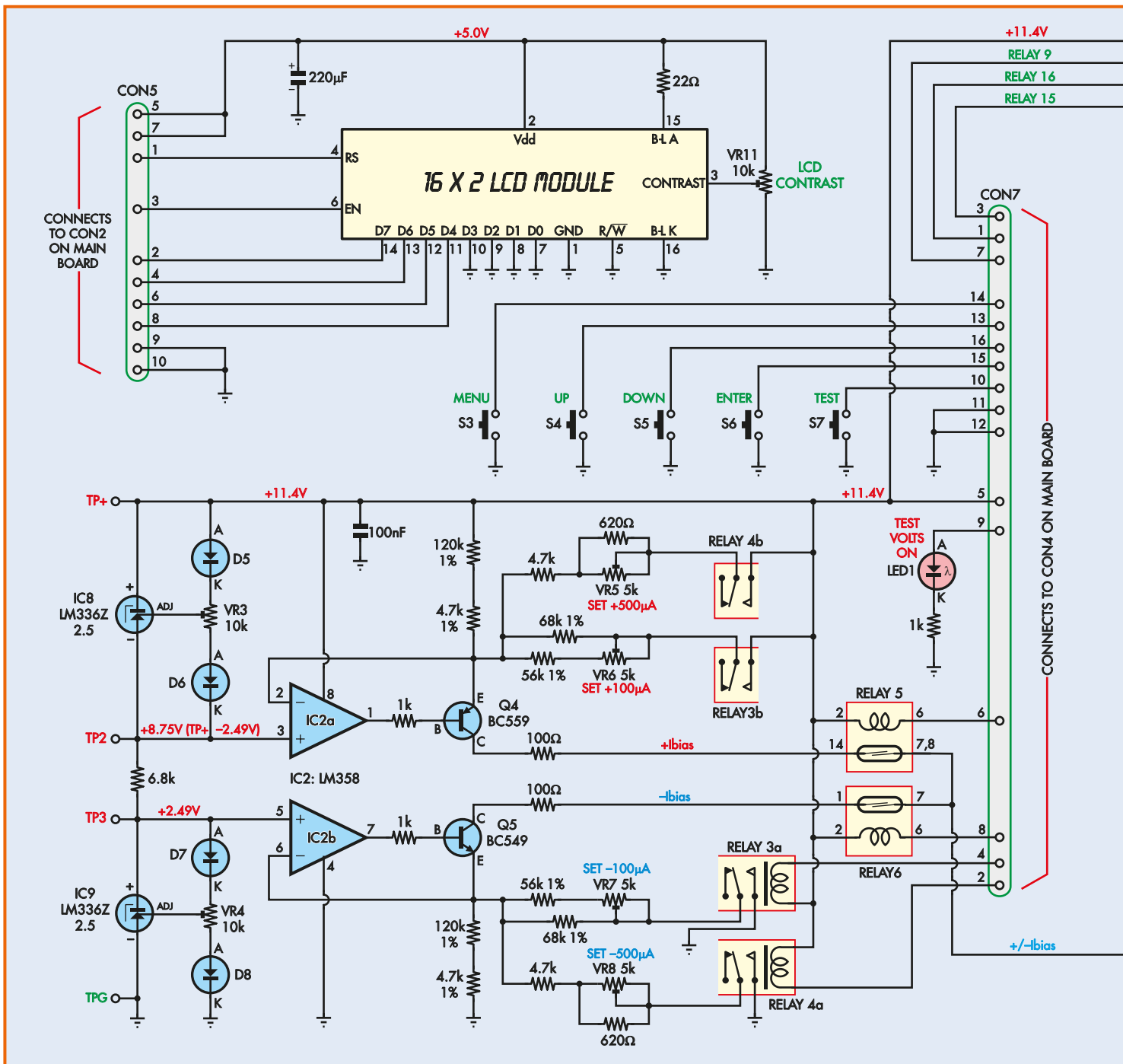

SEMTEST DISCRETE SEMICONDUCTOR TEST SET UPPER BOARD CIRCUIT

Fig.6: the upper board circuit carries the LCD module, an 18-pin ZIF (zero insertion force) socket to connect the device under test (DUT), the control pushbuttons and various relays to switch the device connections to CON6

While we're looking at the DC-DC converter circuitry, note that the second pole of relay 2 (2b) is used to adjust the value of the current-limiting resistance in series with the converter's output, to suit the various output voltage levels. So, for the four output voltage settings selected by S2a, the total current-limiting

resistance is $(1.5k\Omega + (500\Omega/99k\Omega))$, or just under $2k\Omega$. This limits the device current to about 50mA on the 100V range.

On the 'BV' setting (relay 2 off), the current-limiting resistance jumps up to $100.5k\Omega$ – limiting the maximum current to less than 6mA, even if the device under test is shorted.

Crystal X1 and its two associated 27pF capacitors are used to run the micro at 8MHz, which gives an instruction cycle time of 500ns.

Analogue-to-digital conversion

Now let's turn to the micro's ADC module and how it's used to perform the

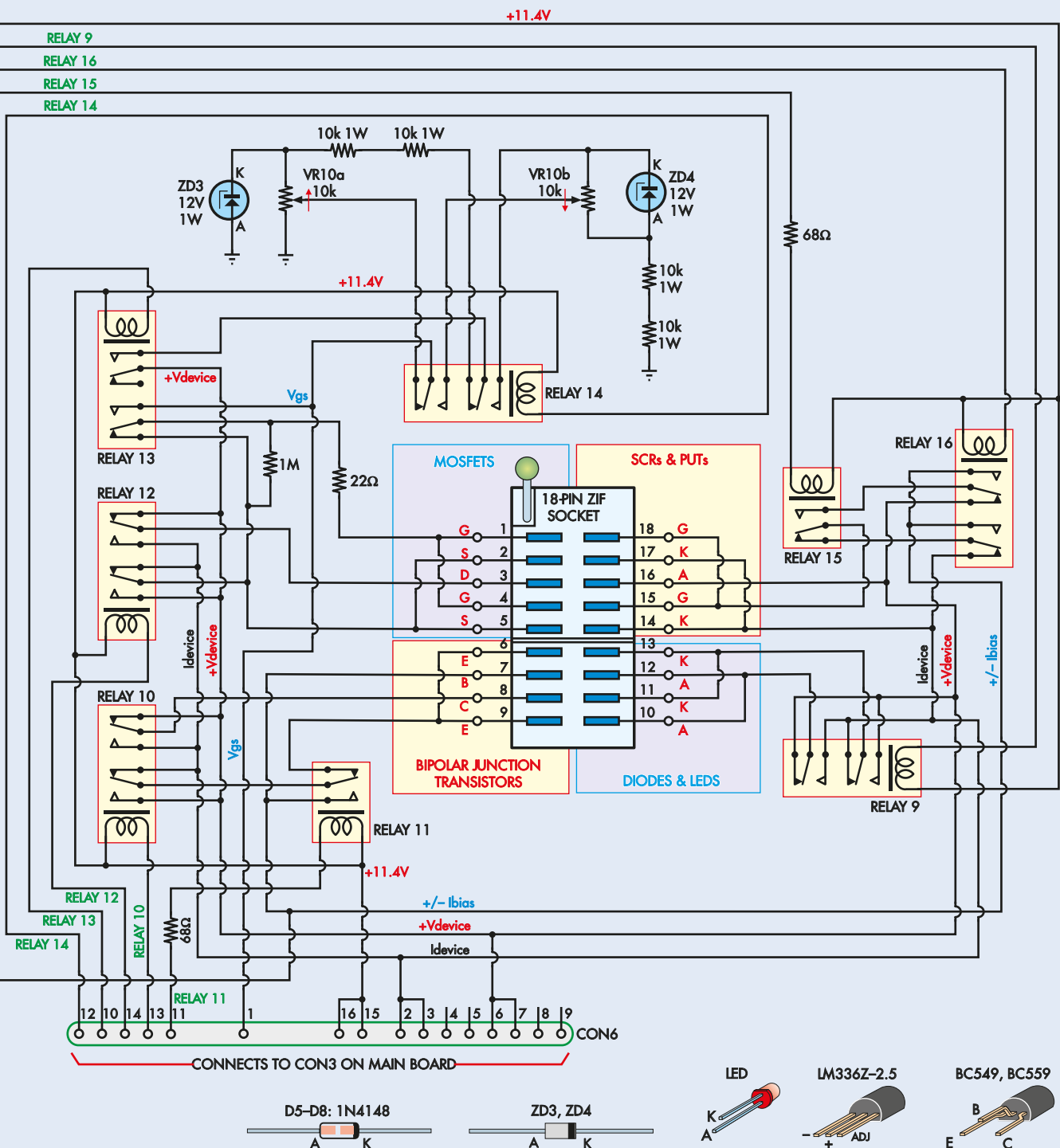

WARNING: SHOCK HAZARD!

The DC-DC step-up converter used in this project can generate high voltages (up to 600V DC) and can also supply significant current. As a result, it's capable of delivering a nasty electric shock and there are some situations where such a shock could be potentially lethal.

For this reason, DO NOT touch any part of the circuit while it is operating, particularly around transformer T1, diode D1 and the two 47µF 450V electrolytic capacitors on the main (lower) PCB. In addition, high voltages can also be applied to the display board (via CON6) during operation, so it's not safe to touch certain parts on this board either. Exercise extreme caution if testing the unit with the lid opened and always allow time for the 47µF capacitors to discharge before working on the circuit.

Note also that high voltages (up to 600V DC) can be present on the component leads when testing for high-voltage breakdown. DO NOT touch any device leads while testing is in progress. Always end the test by pressing the Test On/Off button (red LED off) and check that there is no high-voltage warning on the LCD before removing the DUT (device under test).

Constructional Project

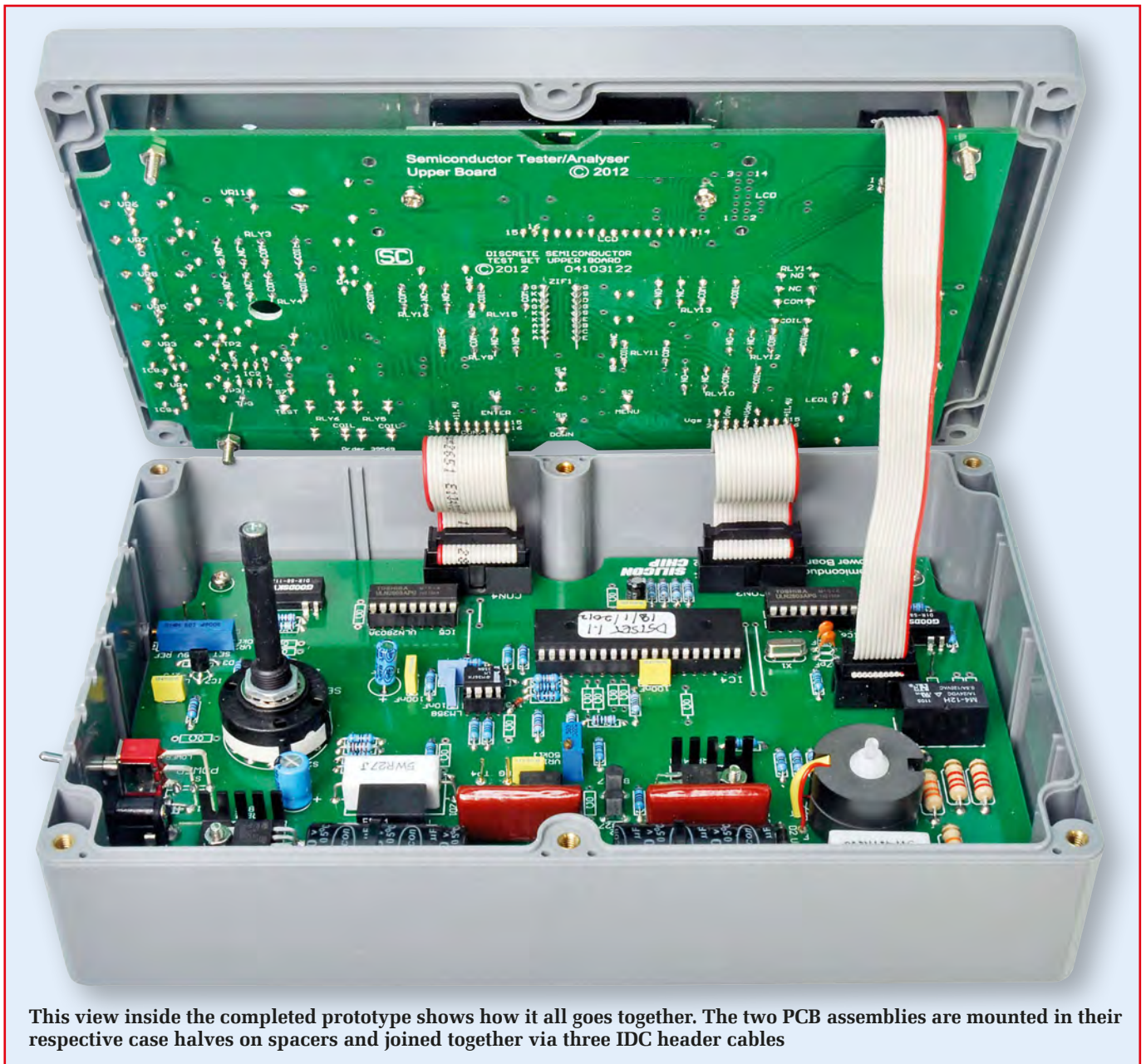

This view inside the completed prototype shows how it all goes together. The two PCB assemblies are mounted in their respective case halves on spacers and joined together via three IDC header cables

SemTest's various metering functions. Starting with the ADC's input channel AN0 (IC4 pin 2), this is used to measure the voltage V_{DEV} being applied to the device under test. Relay 8 is used to switch the upper leg of the voltage divider feeding AN0 to give the V_{DEV} voltmeter two ranges: 0 to 1028V in the case of the higher 'breakdown voltage' or BV range; and 0 to 102.8V for the lower 'OPV' voltage range.

The second ADC input channel AN1 (IC4 pin 3) is used to measure the current I_{DEV} passing through the device under test (DUT). It does this by measuring the voltage drop across a shunt resistance connected between the negative end of the DUT

and ground. Here, relay 7 is used to switch the value of the shunt resistor, to provide two current ranges.

When relay 7 is activated, it shorts the bottom end of the 39 Ω 'upper' shunt resistor to ground, which gives an effective shunt resistance of 39 Ω ; this provides a 0-50mA current range. However, if the micro turns off relay 7, this removes the short across the paralleled 2.7M Ω and 10k Ω resistors, which bumps up the effective shunt resistance to almost exactly 10k Ω , and thus provides a 0 to 200 μ A current range.

On both ranges, the voltage drop developed across the shunt resistance is fed to the micro's AN1 input

via buffer amplifier IC3b, which provides a gain of 1.205. This is used for scaling.

The third ADC input channel, AN2 (IC4 pin 4), is used to measure V_{GS} , the gate-source voltage for MOSFETs. It does this by using another input voltage divider, with the top leg formed by the series 470k Ω and 20k Ω resistors, and the bottom leg by the 10k Ω resistor from pin 3 of IC3a to ground.

This gives a 50:1 input division, which together with the gain of buffer amplifier IC3a (again 1.205) gives a voltage range of 0V to 103.3V. This may seem too high for measuring voltages lower than 20V, but it was only possible to give the AN2 voltmeter a sin-

Parts List – Semiconductor Test Set

- 1 ABS enclosure, 222mm × 146mm × 55mm
- 2 control knobs, 19mm diameter
- 5 SPST pushbutton switches, panel-mount
- 1 18-pin ZIF socket
- 1 18-pin machined IC socket
- 1 18-pin IC socket, wire-wrap type
- 4 M3 × 15mm tapped metal spacers
- 2 M3 × 6mm M3 tapped nylon spacers
- 4 M3 × 25mm machine screws
- 2 M3 × 15mm machine screws
- 10 M3 × 6mm machine screws
- 10 M3 hex nuts
- 2 M3 flat washers, nylon
- 4 16-way (8×2) IDC header sockets
- 2 10-way (5×2) IDC header sockets
- 4 16-way (8×2) pin headers, vertical PCB-mount
- 2 10-way (5×2) pin headers, vertical PCB-mount
- 1 300mm length of 16-way IDC ribbon cable
- 1 180mm length of 10-way IDC ribbon cable
- 1 16-way length of SIL pin header strip

Main board

- 1 PCB, code 890, available from the *EPE PCB Service*, size 210mm × 134mm
- 2 19mm square heatsinks
- 1 6V SPDT mini relay (Jaycar SY-4058 or similar)
- 1 12V DPDT mini relay
- 2 SPST mini DIL relay
- 1 Ferrite pot core, 25mm dia × 16mm high (Altronics L5300 or similar)
- 1 moulded bobbin to suit (L 5305)
- 1 8.0MHz crystal, HC-49S (X1)
- 1 M3 × 25mm nylon machine screw plus nut and washer
- 1 3-pole 4-position rotary switch
- 1 SPDT sub mini toggle switch, PCB-mount
- 2 8-pin DIL IC sockets, PCB-mount
- 1 40-pin DIL IC socket, PCB-mount
- 1 2.1mm concentric DC connector, nylon cable ties
- 4 1mm PCB terminal pins

- 1 1m length of 0.8mm-diameter enamelled copper wire
- 1 10m length of 0.25mm-diameter enamelled copper wire

Semiconductors

- 1 MC34063 switchmode controller (IC1)
- 1 LM358 dual op amp (IC3)
- 1 PIC16F877A microcontroller programmed with 0410312B.hex (IC4)
- 2 ULN2803A octal driver (IC5,IC6)
- 1 LM336Z-2.5 voltage reference (IC7)
- 1 7805 5V regulator (REG1)
- 1 BC337 *NPN* transistor (Q1)
- 1 BC327 *PNP* transistor (Q2)
- 1 IRF540N *N*-channel MOSFET (Q3)
- 1 4.7V 1W Zener diode (ZD1)
- 1 6.2V 1W Zener diode (ZD2)
- 1 1N4004 1A diode (D1)
- 1 UF4007 fast 1A diode (D2)
- 3 1N4148 100mA diode (D3,D4,D9)

Capacitors

- 2 1000µF 25V radial electrolytic
- 1 100µF 10V radial electrolytic
- 2 47µF 450V radial electrolytic
- 1 47µF 16V radial electrolytic
- 2 470nF 630V MKT capacitor
- 4 100nF MKT capacitor
- 2 10nF MKT capacitor
- 1 1nF MKT or polyester capacitor
- 2 27pF NP0 ceramic

Resistors (0.25W, 1%)

- 1 2.7MΩ
- 1 470kΩ
- 4 390kΩ
- 3 300kΩ
- 1 240kΩ
- 1 160kΩ
- 5 100kΩ
- 4 75kΩ
- 3 33kΩ 1W
- 1 20kΩ
- 1 12kΩ
- 9 10kΩ
- 1 5.1kΩ
- 1 3.9kΩ
- 2 3.0kΩ
- 2 2.4kΩ
- 1 2.2kΩ
- 1 1.6kΩ
- 1 1.5kΩ 5W
- 1 1kΩ
- 2 1kΩ 1W
- 2 680Ω
- 2 560Ω
- 1 100Ω
- 1 68Ω
- 2 56Ω
- 1 39Ω
- 1 30Ω
- 1 22Ω
- 1 0.27Ω 5W

- 1 50kΩ multiturn vertical trimpot (VR1)
- 1 10kΩ multiturn horizontal trimpot (VR2)

Upper (display) board

- 1 PCB, code 891, available from the *EPE PCB Service*, size 200mm × 124mm
- 1 16×2 LCD module
- 2 6V SPDT mini relays (Jaycar SY-4058 or similar)
- 8 12V DPDT mini relays (Altronics S4150 or similar)
- 2 SPST mini DIL relay
- 1 8-pin DIL IC socket
- 4 1mm PCB terminal pins

Semiconductors

- 1 LM358 dual op amp (IC2)
- 2 LM336Z-2.5 (IC8,IC9)
- 1 BC559 *PNP* transistor (Q4)
- 1 BC549 *NPN* transistor (Q5)
- 2 12V 1W Zener diodes (ZD3,ZD4)
- 1 5mm red LED (LED1)
- 4 1N4148 100mA diode (D5-D8)

Capacitors

- 1 220µF 10V radial electrolytic
- 1 100nF MKT capacitor

Resistors (0.25W, 1%)

- 1 1MΩ
- 2 120kΩ
- 2 68kΩ
- 2 56kΩ
- 4 10kΩ 1W
- 1 6.8kΩ
- 4 4.7kΩ
- 1 10kΩ mini horizontal trimpot
- 2 10kΩ multiturn horizontal trimpot
- 1 10kΩ linear 16mm dual-gang pot
- 4 5kΩ multiturn horizontal trimpot
- 2 2.2kΩ
- 3 1kΩ
- 2 620Ω
- 2 100Ω
- 2 68Ω
- 1 22Ω

Software

All software program files will be available from the *EPE* website at www.epemag.com.

Although we do not supply pre-programmed microcontrollers, you can purchase the programmed micro featured in this project from: parts@siliconchip.com.au

gle range, and this needs to measure voltages up to around 100V to cope with V_{GS} measurements on *P*-channel devices (where the effective V_{GS} must be found by subtracting the actual V_{GS} from the device voltage V_{DEV}).

ADC reference voltage

The ADC reference voltage for all three of these measuring ranges is provided at pin 5 of IC4, by the voltage reference circuit based on IC7, trimpot VR2 and diodes D3 and D4,

together with a 2.4kΩ load resistor. During set-up, VR2 is adjusted to bring the reference voltage across IC7 as close as possible to 2.490V, where it has a temperature coefficient that's very close to zero.

Constructional Project

All three ADC input circuits have been designed to give the most accurate readings with this reference voltage, so this one adjustment performs the instrument's basic metering calibration.

That's just about it for the main PCB circuitry. However, before moving on, we should point out that the complete instrument runs from an external 12V DC supply which comes in via CON1, polarity protection diode D1 and power switch S1. The resulting +11.4V rail then feeds regulator REG1 (a 7805), which provides +5V to power IC3, IC4, the LCD module and their associated circuitry.

The +11.4V rail itself is also used to supply the various relays and the DC-DC converter based on IC1 – when the micro turns on relay 1 to begin a test. It's also used to power the I_{BIAS} circuitry on the upper PCB, as we shall see in a moment.

Incidentally, the overall current drain of the *SemTest* from the external 12V supply ranges from around 65mA when a test is being set up, to between 150mA and 900mA during testing (depending on the test concerned). A regulated 12V/1A plugpack supply or a 12V SLA lead/acid battery would be suitable.

The upper (display) PCB

Now we can turn our attention to the circuitry on the upper display PCB – see Fig.6. This has the LCD module and control pushbutton switch area at upper left. Trimpot VR11 is used to set the LCD's contrast for maximum readability. The four data lines (D4-D7) and two control lines (EN and RS) are fed from various pins on CON5 and linked back to CON2 on the main board. Similarly, the five pushbutton switches S3 to S7 are simply wired to CON7, which is linked to CON4 on the main board and then to pins 23 to 26 and pin 10 of microcontroller IC4, so the micro can monitor them.

At lower left in Fig.6 are two programmable current sources, used to provide the base current I_{BIAS} for testing BJTs, as well as the gate current for testing SCRs and PUTs. IC8, a 2.490V reference, together with op amp IC2a and PNP transistor Q4, is the positive I_{BIAS} source. Similarly, voltage reference IC9, IC2b and NPN transistor Q5 is the negative I_{BIAS} source (or 'sink', if you prefer).

The 2.490V voltage references (IC8

or IC9) are connected to the non-inverting (+) input of their respective op amps, ie, IC2a or IC2b. The output of each op amp drives the base of the current pass transistor (Q4 or Q5), while feedback to the inverting input of each op amp is taken from the emitter of its pass transistor. Then the emitter of each transistor is taken either to the +11.4V rail (in the case of Q4) or to ground (in the case of Q5), via a series resistance whose value is carefully chosen to have a voltage drop of 2.490V when the transistor's emitter current is at the desired level.

For example, when relay 3 and relay 4 are both off, the emitter resistances for Q4 and Q5 are both equal to 124.7k Ω (120k Ω + 4.7k Ω). As a result, the current passed by either transistor will tend to stabilise at 20 μ A, ie, the level which results in a voltage drop of 2.490V across its emitter resistance.

Relays 3 and 4 are used to switch in different values of emitter resistance for transistors Q4 and Q5, to change the operating currents. For example, when relay 3 is energised by the micro, the 68k Ω and 56k Ω resistors, plus trimpot VR6 (or VR7), are switched in parallel with the fixed emitter resistors, changing the current level of each source to 100 μ A.

Similarly, when relay 4 is energised, the combinations of 4.7k Ω and 620 Ω resistors, plus trimpot VR5 (or VR8), are switched in parallel with the fixed emitter resistors, changing the current level of each source to 500 μ A. So that's how we program the I_{BIAS} current sources for currents of either 20 μ A, 100 μ A or 500 μ A.

Relay 5 and relay 6 are used to switch the output of either the upper + I_{BIAS} source or the lower - I_{BIAS} source, to the device test circuitry. By the way, when either relay 5 or relay 6 (or both) are off, the current sources obviously can't provide any of the three preset current levels. The op amp comparators simply bias their pass transistors 'hard on', ready to pass the appropriate current when current is able to flow.

That covers pretty well all of the circuitry on the left-hand side of Fig.6, apart from LED1, the 'Test Volts On' indicator. This is connected between pin 9 of CON7 and ground, via a series 1k Ω resistor. If you refer back to Fig.5, you'll see that the LED is connected to the +11.4V rail whenever relay

1 switches on the DC-DC converter circuitry, to perform a test.

ZIF socket

In the centre of the right-hand side of Fig.6 you'll see the 18-pin ZIF socket, that's used to connect the various types of discrete semiconductor device to the *SemTest*. The socket's pin clips are divided into four groups: four for BJTs at lower left, five for MOSFETs at upper left, five for SCRs and PUTs at upper right, and the remaining four for diodes and LEDs at lower right.

You'll also note that within each device group there are some clips connected together; this has been done to provide for as many pinout configurations as possible, for each type of device.

Upper board relays

Shown around the ZIF socket are the various relays used to set up the connections for each device type: relay 9 for diodes and LEDs, relay 10 and relay 11 for BJTs, relays 12, 13 and 14 for MOSFETs, and relays 15 and 16 for SCRs and PUTs. If you want to trace out the four separate relay circuits you will find this easier by referring back to the simplified circuits given in Fig.1 to Fig.4 in the first article (February 2013).

The only other part of the circuitry on the right-hand side of Fig.6 is that at top centre, associated with Zener diodes ZD3 and ZD4, and dual-gang pots VR10a and VR10b. These are used to adjust the gate bias voltage, V_{GS} , for MOSFETs, which was also shown in Fig.3 of the first article.

VR10a is used to adjust the positive V_{GS} for N-channel MOSFETs, while VR10b is used to adjust the 'negative' V_{GS} for P-channel MOSFETs.

In operation, the microcontroller works out the effective V_{GS} for the latter devices by subtracting the actual voltage at VR10b's wiper from the device voltage V_{DEV} (which in this case corresponds to the source voltage).

That completes the circuit description. Next month, we will present the construction details. We will also describe an add-on circuit to quickly kill the high voltage applied to the ZIF socket at the conclusion of a breakdown voltage test, or if the *SemTest* is inadvertently switched off before the test has properly concluded.

Not what you expected?

TechnoTalk

Mark Nelson

Not all surprises are welcome; some cause problems and a few can be positively malicious. Fortunately, forewarned is forearmed, which is why Mark has some words for the wise.

MANUFACTURERS have an amusing saying about unified norms. 'Of course we're in favour of industry standards; that's precisely why we support so many different ones.' Unfortunately, it's not a joke, particularly when a standard is not a standard.

Such was the experience of one of our readers, who writes: 'I bought a pair of Philips headphones very cheap from Amazon in their special daily sales, and plugged them into my MP3 player. But garbled sound came out! All my other headphones work fine with the player.'

What was causing this? He answers his own question: 'Well, it seems to be that Philips are making their headphones with a new type of 3.5mm jack plug designed for Apple products (iPhone etc). This has an extra contact segment designed to alter the volume and pause playback, via a small control on the actual cabling. Unfortunately, that extra contact band (making four in total) on the jack plug plays havoc (I assume) with conventional stereo equipment, as I found out to my cost. So they have to go back to Amazon. If you consider that the 3.5mm plug is a universal standard, it's going to cause a lot of trouble in an already confused electronic world.'

Buyers beware

Amazon's web page for the product is hardly crystal clear, describing them as 'Philips O'Neill SHO9567GB/10 Stretch Scratch Headphones with iPhone Control' without any message that the 'phones are suitable only for iPhones. Indeed, it mentions 'Extra 3.5mm plug for Nokia, Sony Ericsson, and Samsung', which implies they can be used with other makes of equipment.

The cardboard box for the headphones states 'for iPhone/Pad etc, but no other plug or adapter is supplied with the product, nor is there any warning that this special jack plays havoc on other equipment. Our reader continues: 'Of course I did test the headphones on an iPhone and they worked perfectly then. But the point is that Philips were selling these with no warning and no adapter. No wonder Amazon was selling them off cheap!'

Unified/proprietary 'standards'

Is there a standard for 3.5mm 'mini-stereo' connectors? Well, yes and

no. There is a very good page on Wikipedia covering the subject with good text and plenty of photos at [http://en.wikipedia.org/wiki/Phone_connector_\(audio\)](http://en.wikipedia.org/wiki/Phone_connector_(audio)). The two and three-pole versions of the plugs and sockets are certainly established standards, but this has not stopped a number of manufacturers from developing non-standard four and five-pole versions of the 3.5mm plug for certain applications.

Wikipedia explains that a four-conductor version is often used in compact camcorders and portable media players, and sometimes also in laptop computers and smartphones, providing stereo sound plus a video signal. Proprietary interfaces using both four and five-conductor versions exist, where the extra conductors are used to supply power for accessories. The four-conductor 3.5mm plug is also used as a speaker-microphone connector on handheld amateur radio transceivers by Yaesu and on some mobile phones.

The author of the Wiki page acknowledges that problems exist, admitting that the possibility of three rings in the plug versus four rings in the socket, and differing pin assignment on the rings makes many *physically* compatible connections *not electrically* compatible. For example, plugging headphones or headsets from one manufacturer into a socket from another may not function. 3.5mm tip-ring-ring-sleeve (stereo-plus-mic) sockets are particularly common on recent smartphones, and have been used by Nokia since 2006; these are often compatible with standard 3.5mm stereo headphones.

Two different formats are frequently found, both of which place left audio on the tip and right audio on the first ring (mirroring the configuration found on stereo connectors). Where they differ is in the placement of the microphone and return contacts. The first, which places the return signal on the second ring and the microphone on the sleeve, is used by Apple's iPhones as well as by HTC, Samsung, Nokia and Sony phones, among others. The second, which reverses these contacts, is used by older Samsung smartphones and some Sony Ericsson phones. One such pin assignment, with ground on the

sleeve, is standardised in the Open Mobile Terminal Platform and has been accepted as a national Chinese standard. Confused? You will be!

More misery?

Well, potentially and specifically for smartphone users. These days, nobody would think of running a computer without antivirus protection (I hope) but the time is not far off when smartphone users will have to gird up their loins too. Cambridge-based data security firm Trend Micro, which claims to be the third largest in this field after McAfee and Norton, has released its security predictions for 2013 and beyond. The challenge in the UK is raising user awareness, says Rik Ferguson, director of security research with Trend Micro.

Mobile users are still unwilling to accept that their phones are under threat. 'Black hole' exploit kits, currently the greatest threat to computer security, are already in use by criminals, he says, and we shall soon see the first exploit kits capable of targeting mobile devices, where your phone can be infected simply by visiting a web page. Currently you need to download a dodgy app to become infected, but toxic websites will be the game changer.

Nobody can state for certain what the most serious threat during 2013 will be, but Trend is convinced it may be malicious and high-risk Android apps. Trend predicts these will reach one million in 2013, up from 350,000 at the end of 2012. And while traditional PC malware may recede a bit during 2013, threats to devices running the Android operating system will more than replace it. Worse, the emergence of more digital lifestyle devices means that threats could appear in new and unexpected places, such as television sets and home appliances.

Feeling uneasy now? Be careful then, because fraudsters are also cashing in on user fear by circulating fake mobile antivirus applications purporting to be legitimate security software. Avoid the risk by buying direct from a genuine developer. A couple of dozen products are available, several *gratis*, and you can find a review of all of them at <http://www.pcadvisor.co.uk/features/security/3355021/group-test-whats-best-android-antivirus/>.

Digital Spirit Level



By ANDREW LEVIDO

This project is really on the . . . errr . . . level. It's an 'inclinometer', an electronic version of the old spirit level, except this one gives a digital readout of the angle of any flat surface in 0.1 degree increments from 0 to 360°. A MEMS accelerometer chip, as found in tablets and smartphones, is at the heart of the project.

MOST of us have a spirit level somewhere in our shed or garage. These handy devices have been around since the mid 1600s, although the modern form of the device dates from the 1920s. A simple air bubble in a slightly curved tube of coloured alcohol can indicate horizontal or plumb (vertical) with surprising accuracy.

Often a quick check for plumb or level is all that is needed, but if you want to measure the actual angle, then you need an inclinometer. You can buy a digital one for up to a couple of hundred pounds or build one for less than £30, thanks to the plummeting cost of MEMS accelerometers.

MEMS (micro electromechanical systems) technology is finding its way into all sorts of consumer electronics these days. Your tablet or smart phone has a MEMS accelerometer, so it knows whether you are holding it in portrait or landscape orientation. Handheld game controllers use both accelerometers and gyroscopes to detect how they are waved, shaken, pointed or flicked. Even my universal remote controller uses one to turn on its LCD when I pick it up.

The *Digital Spirit Level* described in this article uses a typical MEMS chip; the Freescale Semiconductor MMA8451Q. This tiny 16-pin

surface-mount device includes a 14-bit 3-axis accelerometer, together with a sophisticated DSP (digital signal processor) and an I²C interface, all for less than a couple of pounds. Add a low-cost PIC microcontroller, four 7-segment LED displays and a handful of common components and you have all that is necessary for a pretty useful little instrument.

Form factor

Our *Digital Spirit Level* has a form factor that's similar to a small spirit level, and can measure angle of tilt with an accuracy of 0.1° over the full 360° of rotation. Operation could not be

simpler. Just pick up the device and give it a shake to bring it to life, then place it on the surface you want to measure. It will stay awake while it senses movement, and it will automatically turn off after 30 seconds of inactivity.

How it works

The inclinometer measures its orientation with reference to the acceleration due to gravity, which, conveniently for us all, always points straight down. We nominate the side-to-side horizontal axis of the accelerometer as 'x', the top-to-bottom axis as 'y' and the front-to-back axis as 'z'.

If the accelerometer is level, gravity will be perfectly aligned with the y axis. However, when tilted as shown in Fig.1, there will be components of gravitational acceleration (ie, $G \times \sin\theta$ and $G \times \cos\theta$) along both the 'x' and 'y' axes, depending on the tilt angle.

Using trigonometry, we could calculate the angle of tilt from the measured acceleration along the x or y axis, as long as we knew the gravitational acceleration. Unfortunately, this varies from the nominal 9.8ms^{-2} depending on location, since the Earth is neither perfectly spherical nor uniformly dense.

Fortunately, we can use the trigonometric identity $\tan\theta = \sin\theta/\cos\theta$, to solve our problem. If we take the inverse tangent (arctangent) of the ratio of accelerations along the x and y axes, the gravity terms cancel out and we arrive at the angle of inclination using only the acceleration values.

So the angle can then be determined by using the formula $\theta = \text{atan}(x/y)$ where x and y are the measured accelerations along the two axes.

However, there is another complication. If the inclinometer tilts around the x-axis (ie, the x-y plane is no longer vertical), a component of the acceleration due to gravity appears on the z-axis, and the components along the x and y-axes reduce. Ultimately, with the inclinometer lying flat on its back, the x and y components reduce to zero, as all of the acceleration now acts in the z-direction. The falling amplitude of the x and y accelerations as the x-y plane tilts about the x-axis progressively reduces the accuracy of the measurement.

The *Digital Spirit Level (Inclinometer)* described here can maintain 0.1°

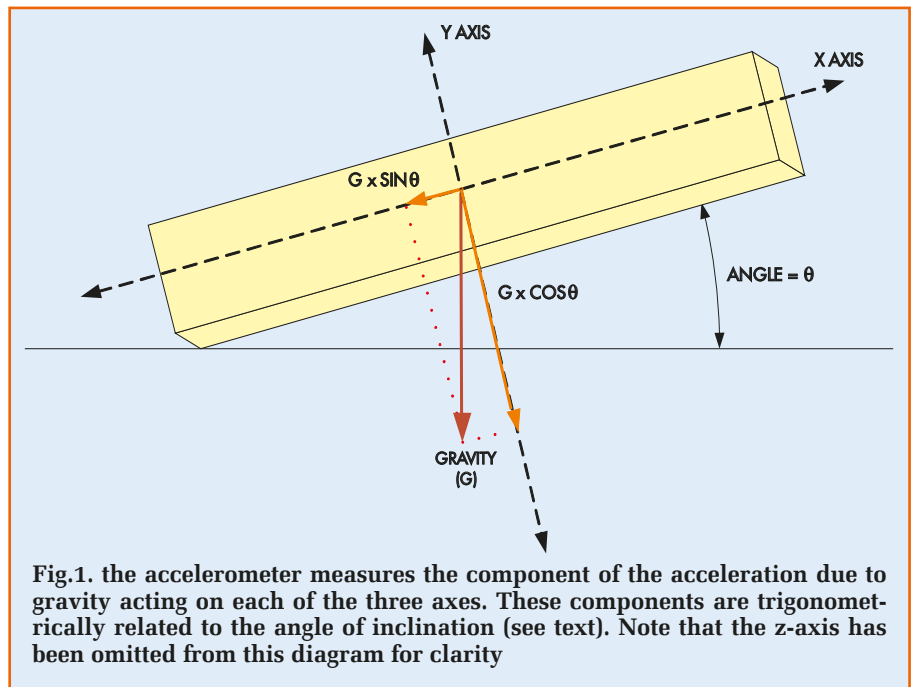

Fig.1. the accelerometer measures the component of the acceleration due to gravity acting on each of the three axes. These components are trigonometrically related to the angle of inclination (see text). Note that the z-axis has been omitted from this diagram for clarity

accuracy, up to the point where the tilt about the x-axis reaches $\pm 45^\circ$. The microcontroller (IC2) therefore keeps track of all three angles, and displays four dashes in place of the measured angle if this level of accuracy cannot be guaranteed.

Wake and sleep modes

As described above, the main ICs in the *Spirit Level* are in a low-power deep-sleep mode when it is not being used and 'wake up' when movement is sensed. The circuit remains awake until it senses that it has not moved for about 30 seconds.

The MMA8451Q's built-in DSP looks after the detection of movement and the consequent transition between wake and sleep modes. This is just one of the many features of the chip; see the panel titled 'Inside the MMA8451Q' for further information on this device.

The DSP algorithm considers motion to be an acceleration that exceeds a programmable threshold for a programmable period of time. Optionally, the acceleration signals can be high-pass filtered first, to eliminate static effects (such as gravity). In addition, motion detection can be enabled on each axis independently.

We set the motion sensitivity threshold fairly low while the unit is awake, so that relatively small movements suffice to keep it that way. Conversely, in sleep mode, the sensitivity is reduced so that a solid 'air swing' is required to

wake the level up. This prevents the device from being woken up by every small knock or vibration, as might be experienced in a moving vehicle for example.

Circuit description

The full circuit diagram in Fig.2 shows that the *Digital Spirit Level* uses just two chips – the MEMS accelerometer (IC1) and a PIC18LF14K22 microcontroller (IC2). The latter drives the anodes of the four 7-segment LED displays directly and the common cathodes indirectly via four MOSFETs (Q1 to Q4).

The circuit is powered directly by a pair of AA batteries, with $10\mu\text{F}$ and 100nF capacitors providing bulk filtering and high-frequency bypassing respectively. The accelerometer (IC1) supply is then further filtered by a 10Ω resistor and a $10\mu\text{F}$ and 100nF capacitor, which prevent any ripple generated by driving the display from affecting the measurements of the accelerometer.

The PIC micro communicates with the accelerometer using an I²C bus (pin 6 [SDA] and pin 4 [SCL] of IC1) and two interrupt lines (pin 9 and pin 11 of IC1). Two $4.7\text{k}\Omega$ resistors are used as the usual 'pull-ups' for the I²C bus.

The accelerometer is configured to generate a negative-going interrupt pulse on pin 11 (INT1) each time a new acceleration sample is available. Similarly, a negative-going interrupt

Constructional Project

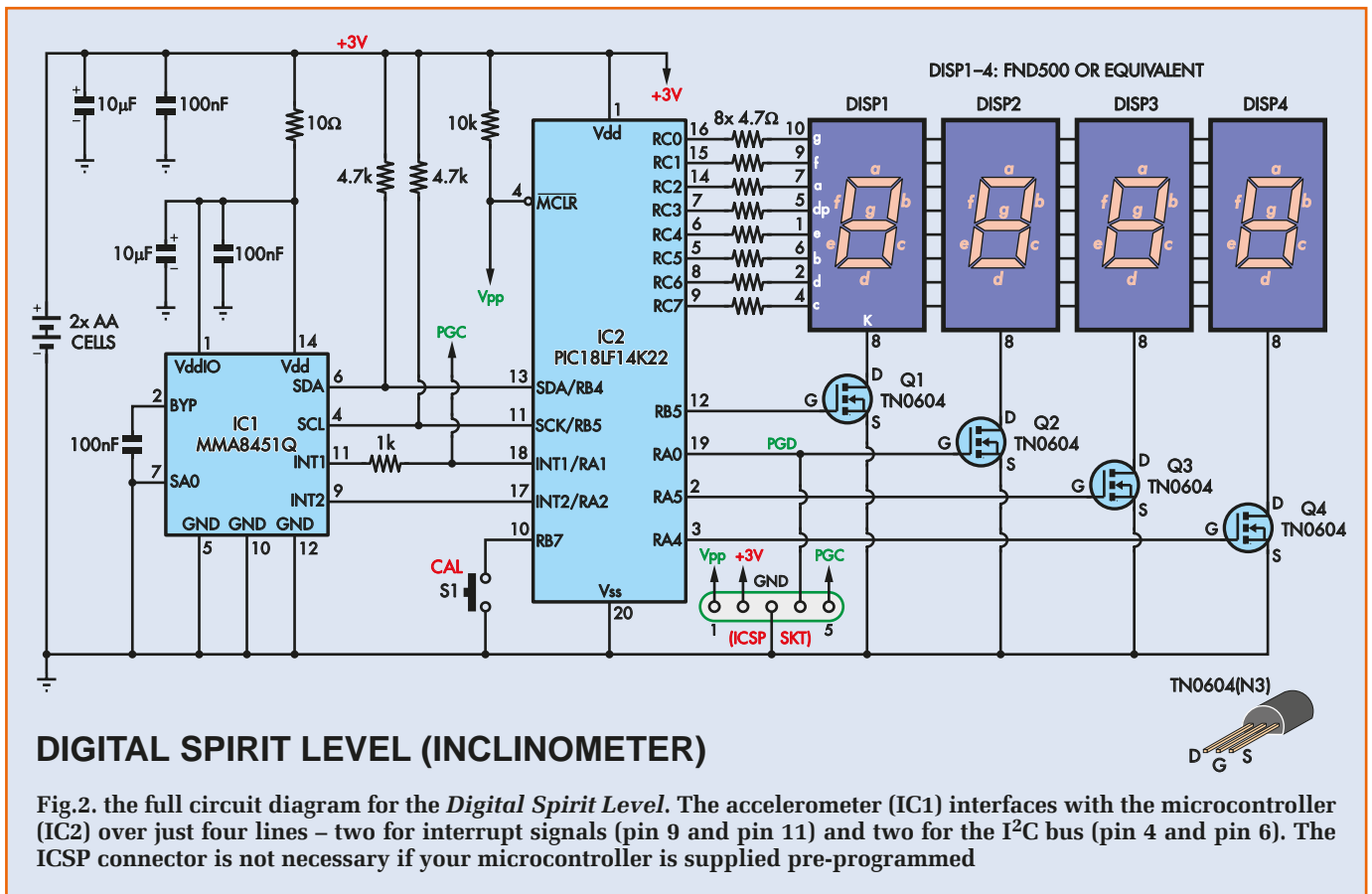

pulse appears on pin 9 (INT2) of the accelerometer whenever it detects movement, or changes between sleep and its wake states.

Pin 18 (RA1) on the PIC microcontroller serves double-duty, functioning both as an interrupt input and as the clock input for in-circuit programming. The 1kΩ resistor is required to ensure that the in-circuit serial programmer (ICSP) interface can drive pin 18 without interference from the accelerometer, for programming the micro. The ICSP data input is shared with pin 19, one of the digit driver outputs. No similar resistor is required here because the MOSFET gate is high impedance and hence won't affect programming.

The display is a classic multiplexed common-cathode 7-segment arrangement. The eight 4.7Ω resistors on pins RC0 to RC7 provide current limiting for the segment LEDs, although in reality the microcontroller outputs themselves limit the drive current to about 20mA per segment. MOSFETs Q1 to Q4 are used to drive the digits' common cathodes, rather than the usual bipolar transistors, because they can provide a very low 'on' resistance,

even when driven at a low voltage. With only 3V to play with (less if the battery is discharged), we can't afford the few hundred millivolts drop that bipolar transistors would exhibit.

The firmware

The firmware is fairly straightforward. The main program sets up the microcontroller peripherals, configures the accelerometer and then enters an endless loop. From there on, everything occurs in one of four interrupt service routines. One interrupt, triggered by an internal timer, multiplexes the display. The interrupt occurs every 5ms, which therefore takes 20ms to display all four digits, for a 50Hz refresh rate.

The second interrupt service routine is triggered by a falling edge on pin 18 of the micro, indicating that new accelerometer data is available. When the accelerometer is awake, this occurs every 640ms. The firmware reads the new data via the I²C bus, calculates the angle, subtracts the offset value stored in EEPROM and updates the display (more on the offset value later).

The third interrupt service routine is triggered by a falling edge on pin 17. This indicates either that the accelerometer has switched between its wake and sleep states, or that movement has occurred. We are only interested in the wake-to-sleep transition, so when the interrupt occurs, the micro interrogates the accelerometer to find the source of the interrupt.

If the accelerometer has gone to sleep, the firmware turns off the display and puts the microcontroller to sleep too, configuring it to wake up only when a new interrupt occurs on pin 17. This happens only when there is further movement that re-awakens the accelerometer.

The final interrupt service routine is invoked when the user presses and releases the calibration switch button (S1). This routine zeroes the display and stores the current angle as the offset value in the micro's internal EEPROM memory.

This allows you to compensate for any imperfection in the alignment of the mechanical axes of the accelerometer relative to the case. It's unlikely that the accelerometer IC is perfectly

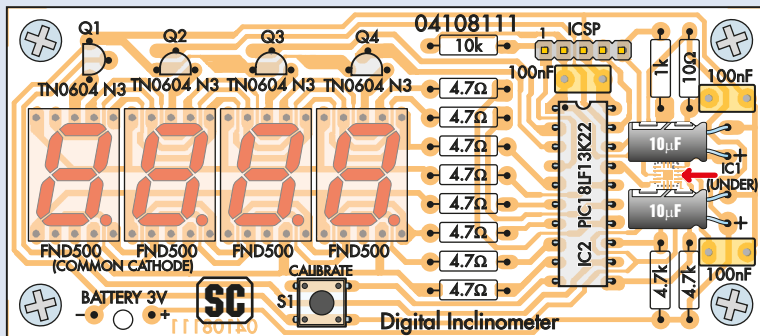
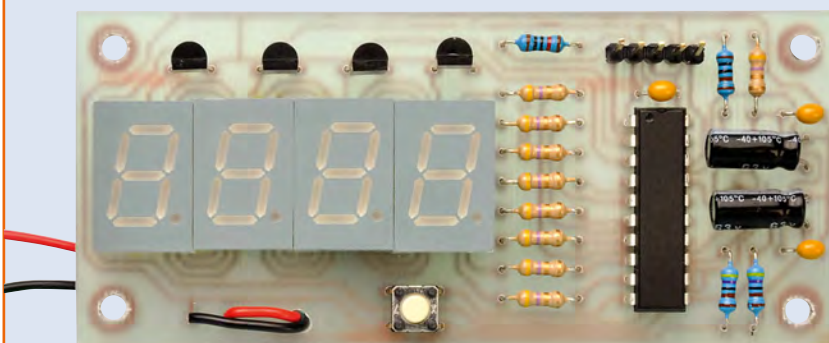

Fig.3. install the parts on the PCB as shown on this layout diagram. Note that the two 10µF capacitors must be mounted on their sides



This prototype differs slightly from the final version shown in Fig.3 (eg, Q1 is oriented differently and the hole for the battery leads has been moved)

aligned with the metal case (due to both misalignment between the IC and PCB, and the PCB and the case) but this can be compensated for to give a zero reading on a perfectly level surface.

Power consumption

In sleep mode, the micro draws less than 100nA and the accelerometer only 14µA – amazing considering it is still measuring acceleration and checking for movement. In use, the inclinometer draws around 50mA, most of which is consumed by the display. With moderate usage therefore, the two 1.5V AA batteries should last many months.

The *Digital Spirit Level* monitors the battery voltage and when it falls to around 2.85V, lights one decimal point on the display to indicate that the battery is low. Since every pin on the micro is used, we had to resort to a clever trick to monitor the battery.

The ADC of the microcontroller is configured to measure a fixed internal 1.024V band-gap voltage using the supply voltage as the reference. This is the opposite of the way we would normally do things and means that as the battery voltage falls, this measurement actually increases. It's not a linear relationship,

but it is more than adequate for detecting a low battery level.

Construction

The *Digital Spirit Level* is built on a small, single-sided PCB measuring just 100mm × 44mm. This board is available from the *EPE PCB Service*, code 889.

The topside component layout is shown in Fig.3. Surface mount IC1 is soldered to the underside – see Fig.4. All components are through-hole types with the exception of the accelerometer (IC1), which is in a tiny 16-pin QFN (surface-mount) package. This is the first thing you should fit. It takes some patience and a steady hand, but it can be soldered in manually.

First, carefully tin the pads. You want a thin, even layer of solder, so use solder wick to clean up any bumps or shorts between pads. Check very carefully for solder shorts between pads at this point, and fix them now. Once the chip is down, you will not be able to see the joints.

Now carefully place the accelerometer on the pads, lining up the tiny pin 1 dot on its body with the corresponding dot on the PCB layout. In addition, make sure that the chip is properly

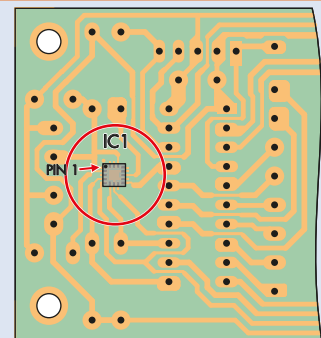

(UNDERSIDE OF BOARD)

Fig.4: the MMA8451Q is mounted on the copper side of the PCB, as shown here

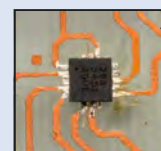

Left: a close-up view of the MMA-8451Q in position. Be sure to orient it correctly with the PCB dot

lined up with the pads on all four sides. The small marks on the sides of the chip indicate the pin positions, and these must be perfectly lined up with their corresponding pads.

Once it's fully lined up, you need to melt the solder under each pad, without moving anything.

If you have a hot-air rework station, you can use this to gently heat the chip until the solder reflows. If you don't, you need to use a soldering iron to apply heat to each pad in turn, all the while holding the chip in place. The idea is to melt that thin layer of solder you applied to the pads and to heat the corresponding contact on the chip so that the two bond. Take your time, but try not to overheat the accelerometer.

Now use a multimeter to check for any unintentional shorts between adjacent pads. If there is a solder short between two adjacent pins, you will be able to remove it using solder wick.

Topside board

Once the accelerometer (IC1) is in position, the remaining topside parts can be installed in order of height, ie, from lowest to highest. Note that the MOSFETs (Q1 to Q4) have to be pushed down so that they do not stand proud of the 7-segment displays. Likewise, the two electrolytic capacitors are mounted on their sides (ie, with their leads bent down at right angles), so that they are lower than the display faces.

The 7-segment displays are soldered directly to the PCB. Make sure that

Constructional Project

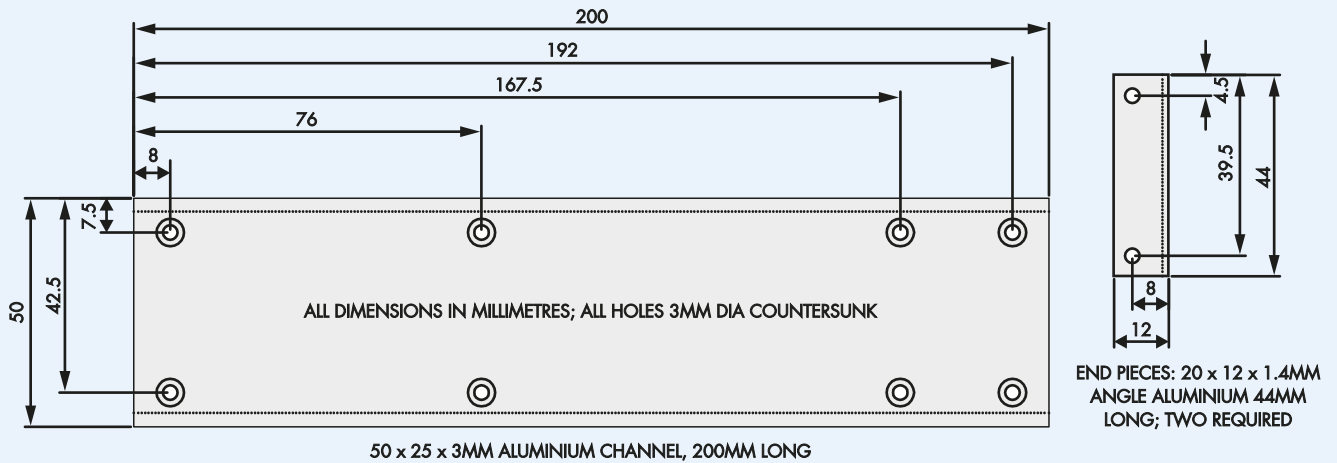

Fig.5: the base is made from a 200mm length of 50mm x 25mm x 3mm aluminium channel, while the two end pieces (right) are made from 44mm lengths of 20mm x 12mm x 1.4mm aluminium angle extrusion

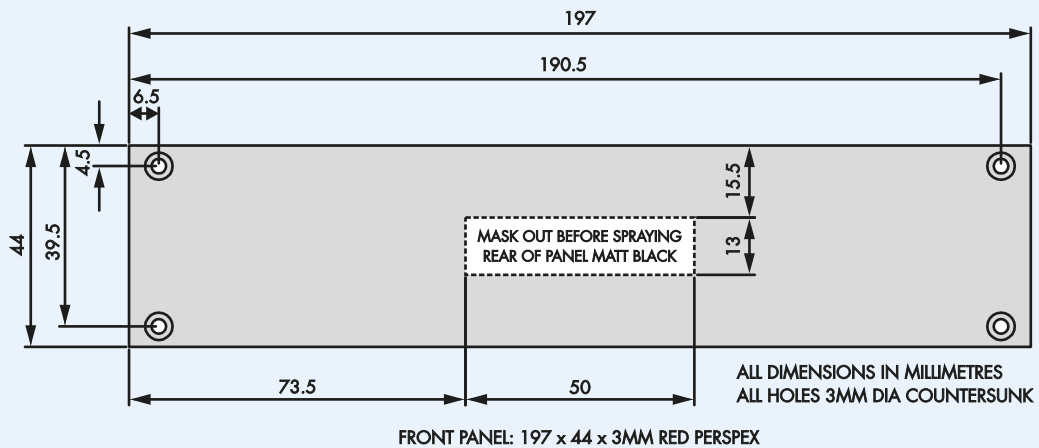
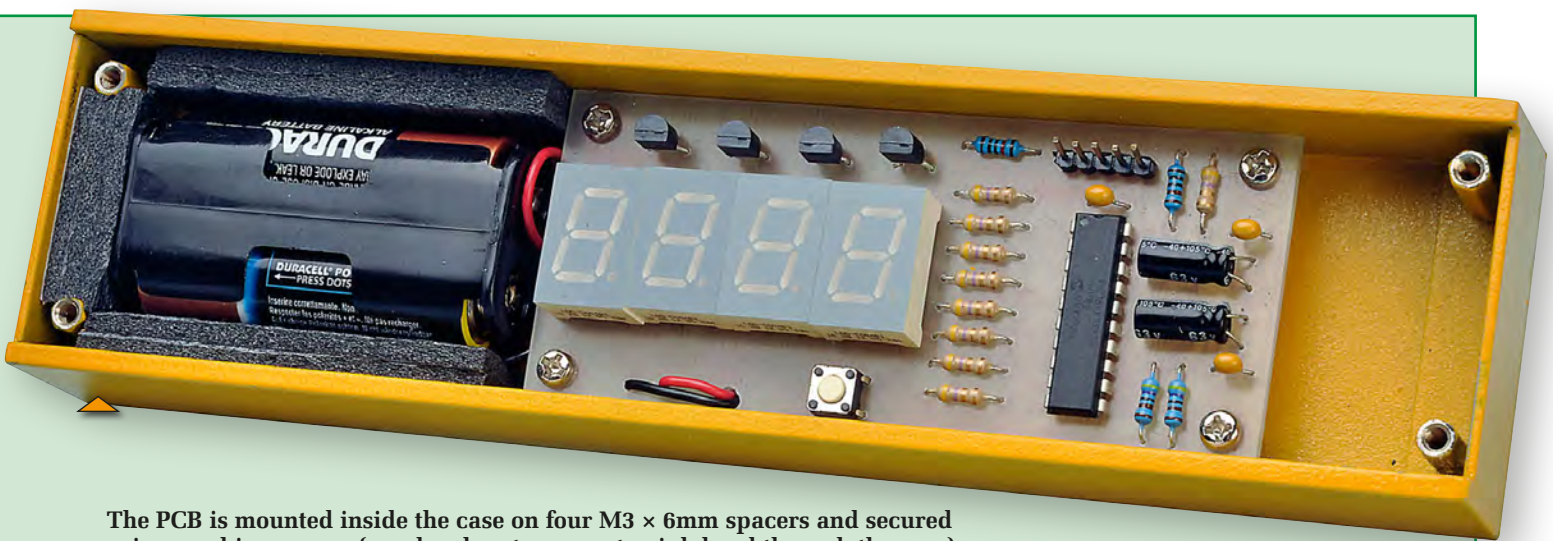

Fig.6. the front panel is made from 3mm red perspex. Drill and countersink carefully because the material fractures easily. The back of the panel is sprayed matte black, except for the display window shown dotted



Left: this is the view inside the case before the PCB and battery are installed. The end pieces are secured using M3 x 6mm countersink-head screws and M3 x 16mm tapped metal spacers. The Perspex front panel (below) is spray-painted matte black on the inside, with the display window masked out





The PCB is mounted inside the case on four M3 × 6mm spacers and secured using machine screws (pan head on top, countersink head through the case)

they sit flush with the board surface and that they are oriented correctly (ie, each decimal point at lower right).

Board check

Having completed the board assembly, attach the battery holder and insert a pair of fresh AA cells. If everything is working correctly, the display will show four dashes while the PCB is face up.

Now slowly tilt the board up to vertical with its long edge on the bench and check that it displays an angle within a few degrees of horizontal (ie, just above 0.0 or just below 360.0). If that checks out, hold it perfectly still for about 30 seconds. At the end of this period, the display should go blank as the device falls asleep. When it does, give it a firm shake to wake it up again.

Finally, check the calibration button by positioning the board at an angle of a few degrees and briefly pressing the calibration button. When the button is released, the display should read zero.

Troubleshooting

If there is no display, check that the component values and orientations are

correct. That done, visually inspect the solder side for bad joints or solder shorts. If that looks OK, use a multimeter to check for 3V on the micro's supply pins (ie, between pin 2 and pin 20), and check that the MCLR pin is pulled high.

If you have access to a scope or frequency counter, check for 5ms pulses repeated every 20ms at the gates of the MOSFETs. If these are present, you can be confident the micro is operating.

If the micro is working but no angle measurement takes place, the problem probably lies with the soldering of the accelerometer. In that case, remove the batteries and inspect your work with the aid of a magnifying glass. Since you checked for shorts earlier, the most likely problem is an open-circuit pin, so carefully resolder each one using a fine-tipped iron and applying very small amounts of solder.

Basically, you want the solder to melt and wick up under the chip. If you inadvertently apply too much solder, use solder-braid to remove the excess.

Housing

We made the housing from a length of 50mm × 25mm × 3mm aluminium channel (a standard extrusion that should be available from your local aluminium centre). The end pieces are also aluminium extrusions, this time 20mm × 12mm × 1.4mm angle extrusion.

You will have to cut and drill the aluminium as shown in Fig.5, taking care to de-burr all the holes. If you want a form factor more akin to a spirit level, you can cut the 50mm channel longer than shown, so that it extends out either side of the end-pieces.

The front panel is a piece of translucent red perspex, cut and drilled according to Fig.6. Keep the protective film in place as long as possible to avoid scratches. The inside of the perspex is spray-painted matte black, after masking off the rectangular section that will be directly in front of the LED displays (see above photo).

The best way to make this mask is to first peel off the protective film on the inside surface and then cover the central section (ie, where the display window goes) with masking tape.

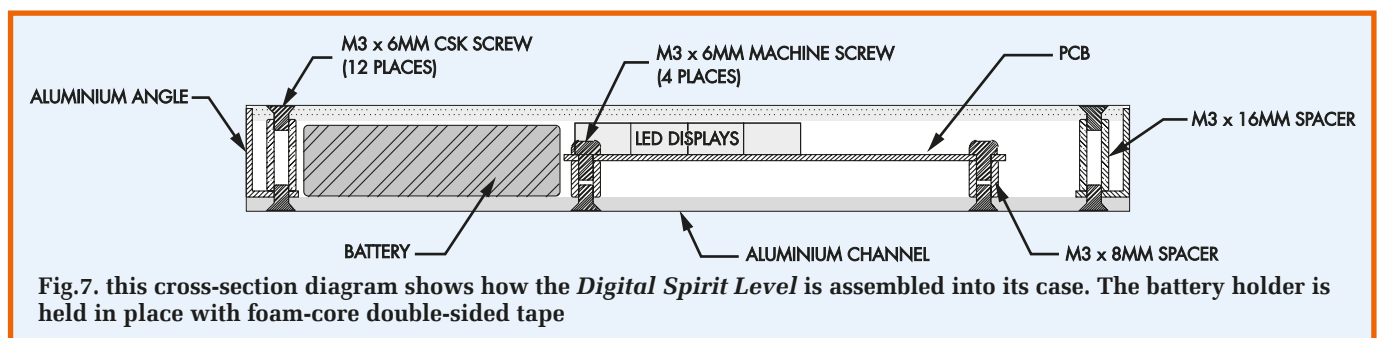
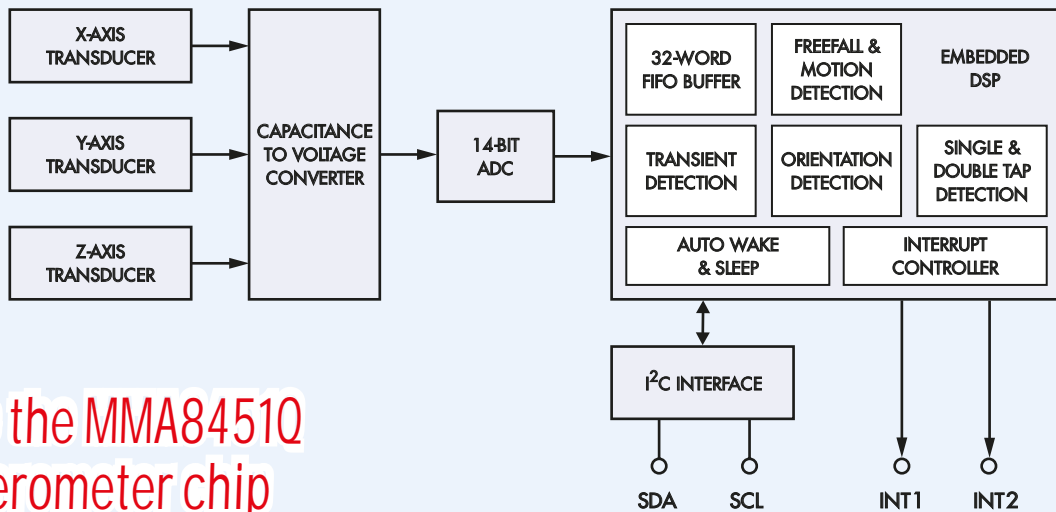

Fig.7. this cross-section diagram shows how the *Digital Spirit Level* is assembled into its case. The battery holder is held in place with foam-core double-sided tape



Inside the MMA8451Q accelerometer chip

The Freescale Semiconductor MMA8451Q is a 14-bit 3-axis accelerometer with a built-in DSP (digital signal processor) and a plethora of embedded functions. The acceleration transducers are MEMS (micro electromechanical systems) technology, which combines on-chip nano-scale mechanical parts with electronic components.

In this case, each transducer is a microscopic sprung mass, which forms the moving plate of a capacitor. As the mass moves against the spring, under the influence of acceleration, the capacitance changes. The capacitance is converted to a voltage and then digitised by the 14-bit ADC for processing by the on-board DSP.

The gain can be configured for full-scale readings of $\pm 2g$, $\pm 4g$ or $\pm 8g$ and the transducers are sampled at a programmable rate of up to 800 times per second. Naturally, faster sampling increases power consumption.

Although the ADC has 14-bit resolution, the effective resolution of the device is limited by mechanical and electronic noise. The signal-to-noise ratio (SNR) can be improved by oversampling, where multiple samples are averaged into each reading. Many combinations of sampling rate and oversampling are available, allowing the user to trade off accuracy, update rate and power consumption.

The sampled data is available for direct readout via the I²C bus, but much of the real power of this device comes with the embedded DSP functions. The chip is extremely flexible, if a little difficult to master, with a 50-page datasheet and more than 40 configuration registers.

For example, the output data may be directed to a FIFO (first in, first out) buffer capable of storing up to 32 samples. This means that at high sample rates, the microcontroller can wait until several samples have accumulated before reading them all in one go. The FIFO can even be read out while simultaneously capturing data.

A freefall/motion detector can detect when the device is falling. This is often used in portable devices to park the hard disk drive read heads safely before impact. Alternatively, this functional block can be configured to detect motion. The user can configure both the level and duration of movement required to qualify as valid motion, configure a high-pass filter and nominate which axes are to be monitored.

Orientation function

An orientation function detects whether the accelerometer is oriented in 'portrait' or 'landscape' mode, whether it is face up or face down, and whether

it's upright or upside-down. The transition points and the hysteresis between them are configurable.

The transient function detects fleeting events such as flicks and shakes. This makes use of a configurable high-pass filter and configurable level and duration thresholds. Another block can detect single and double-tap events and can determine on which axis and in which direction the tap originates. Once again, the amplitudes, durations and delays are all programmable via the I²C interface.

Most of these functions can be selected as inputs to the auto sleep/wake function, which either puts the device into a sleep mode or wakes it up. The device is still active in sleep mode; it just falls back to a (programmable) lower sampling mode and rate. Current consumption can be as low as $6\mu A$ in this state, even though the chip is fully functional. There is also a standby mode.

The MMA8451Q also contains an interrupt controller. The interrupt sources include all the functional blocks, the availability of new data and the sleep/wake logic. Any source can be directed to either of the two outputs and the outputs can be configured for polarity. You can even select whether the outputs are push-pull or open drain!

Make sure you slightly overlap each strip so that there are no gaps.

That done, carefully measure and draw the rectangular window on to the tape. You can now use a sharp hobby knife and a metal straight-edge to cut through the tape around the window.

Don't press too hard – you want to cut through the tape but not score the perspex too deeply. Finally, you can peel off the excess tape, leaving just a neat rectangle in the middle, ready for spraying.

Fig.7 shows how the whole thing goes together. The end pieces are

each held in place by two $M3 \times 16mm$ spacers, which are secured using $M3 \times 6mm$ countersunk machine screws. These spacers also support the front panel. The PCB is supported on four $M3 \times 8mm$ spacers, and these are also secured



Reproduced by arrangement
with SILICON CHIP
magazine 2013.
www.siliconchip.com.au

The completed *Digital Spirit Level* is shown here, together with a conventional spirit level at the rear. The unit measures in 0.1° steps from 0 to 360° (the resting surface here is not quite level)

to the case using M3 × 6mm countersunk machine screws.

It's best to test-fit the whole assembly, then use some Loctite to secure the eight countersunk screws holding the spacers into the housing.

You can now paint the case to your liking, ensuring you don't get paint in the threads of the spacers. Once that's done, add some foam-core double-sided tape inside the case to hold the battery in place (see photo) and secure the PCB using four M3 × 6mm pan head screws.

Calibration

To calibrate the unit, place it on a known level surface (a 2-metre spirit level will typically be accurate to 0.05°) and press the calibrate switch. Alternatively, you could level a piece of timber or metal using a water level made from clear plastic tubing.

Pressing switch S1 now automatically calibrates the unit. You can confirm that it is correct by checking that the unit indicates 0° when it is oriented in either direction.

The unit can then be completed by fitting the perspex front panel and securing it using four M3 × 6mm countersunk machine screws.

That's it! Your new *Digital Inclinometer* is now ready for use. It's a simple project that nicely demonstrates the power and versatility of tiny MEMS devices.

Parts List – Digital Spirit Level

- | | |
|--|---|
| 1 PCB, code 889, available from the <i>EPE PCB Service</i> , size 100mm × 44mm | 1842359 – www.element14.com |
| 1 tactile pushbutton momentary switch (S1) | 1 PIC18LF14K22-I/P programmed microcontroller with 0410811B. hex (IC2) (Element14 order code 1770702) |
| 1 5-way pin header (ICSP) (2.54mm pitch) | 4 TN0604N3 MOSFETS (Q1 to Q4) (Mouser* 689-TN0604N3-G) |
| 1 2 × AA battery holder | 4 FND500 7-segment LED displays or equivalent |
| 1 200mm-length of 50mm × 25mm × 3mm aluminium extrusion | Capacitors |
| 2 44mm lengths of 20mm × 12mm × 1.4mm aluminium angle extrusion | 2 10µF 16V electrolytic |
| 1 red perspex sheet, 197mm × 44mm × 3mm | 3 100nF MKT or monolithic ceramic |
| 4 M3 × 16mm tapped spacers | Resistors (0.25W, 1%) |
| 4 M3 × 8mm tapped spacers | 1 10kΩ 1 10Ω |
| 12 M3 × 6mm countersunk machine screws | 2 4.7kΩ 8 4.7Ω |
| 4 M3 × 6mm pan head machine screws | 1 1kΩ |
| 1 330mm × 20mm × 3mm length of closed-cell foam | |
| 1 180mm length of regular double-sided tape | |
| 1 60mm length of foam-core double-sided tape | |
| Masking tape | |
| Black and yellow paint | |
| Semiconductors | |
| 1 MMA8451Q 3-axis accelerometer (IC1) (Element14 order code | |

Software

All software program files will be available from the *EPE* website at www.epemag.com.

Although we do not supply pre-programmed microcontrollers, you can purchase the programmed micro featured in this project from: parts@siliconchip.com.au

UK readers you can **SAVE 94p** on every issue of *EPE*

How would you like to pay £3.46 instead of £4.40 for your copy of *EPE* ?



Well you can – just take out a one year subscription and save 94p an issue, or £11.28 over the year. You can even save £1.15 an issue if you subscribe for two years – a total saving of £27.60.

Overseas rates also represent exceptional value.

You also:

- Avoid any cover price increase for the duration of your subscription
- Get your magazine delivered to your door each month
- Ensure your copy, even if the newsagents sell out

Order by phone or fax with a credit card or by post with a cheque or postal order, or buy online from www.epemag.com (go to the Online Shop).

EPE EVERYDAY PRACTICAL ELECTRONICS

SUBSCRIPTION PRICES

Subscriptions for delivery direct to any address in the UK: 6 months £21.95, 12 months £41.50, two years £78.00; Overseas: 6 months £25.00 standard air service or £35.00 express airmail, 12 months £48.00 standard air service or £68.00 express airmail, 24 months £91.00 standard air service or £131.00 express airmail.

Cheques or bank drafts (in £ sterling only) payable to *Everyday Practical Electronics* and sent to EPE Subs. Dept., Wimborne Publishing Ltd., 113 Lynwood Drive, Merley, Wimborne, Dorset, BH21 1UU. Tel: 01202 880299. Fax: 01202 843233. Email: subs@wimborne.co.uk. Also via the Web at: www.epemag.com.

Subscriptions start with the next available issue. We accept MasterCard, Maestro or Visa. (For past issues see the Back Issues page.)

ONLINE SUBSCRIPTIONS

Online subscriptions, for reading the magazine via the Internet, £19.99 for one year, visit www.epemag.com for more details.

SUBSCRIPTION ORDER FORM

- 6 Months: UK £21.95, Overseas £25.00 (standard air service), £35.00 (express airmail)
- 1 Year: UK £41.50, Overseas £48.00 (standard air service) £68.00 (express airmail)
- 2 Years: UK £78.00, Overseas £91.00 (standard air service) £131.00 (express airmail)

To: *Everyday Practical Electronics*, Wimborne Publishing Ltd., 113 Lynwood Drive, Merley, Wimborne, Dorset BH21 1UU
Tel: 01202 880299 Fax: 01202 843233
E-mail: subs@epemag.wimborne.co.uk

I enclose payment of £ (cheque/PO in £ sterling only), payable to *Everyday Practical Electronics*

Please charge my Visa/Mastercard/Maestro

My card number is:
Please print clearly, and check that you have the number correct

Signature

Card Security Code Valid From Date.....
(The last 3 digits on or just under the signature strip)

Card Ex. DateMaestro Issue No.

Name

Address

Post code Tel.

Subscriptions can only start with the next available issue.



RKPK40

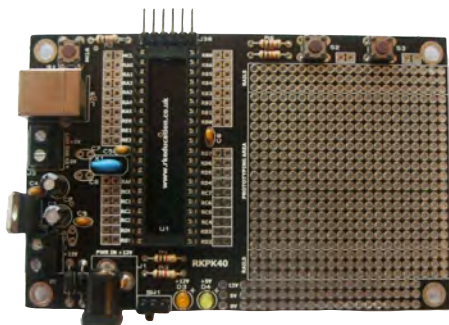

Prototype PCB designed for use with PIC MCUs

- Designed for use with 40 pin PICs
- Large prototyping area with power rails
- Power supply circuit
- USB socket
- PickIt programming header
- Only £9.99

Available now online from,

www.rkonlinestore.co.uk

A wide range of electronic projects are available

SHERWOOD ELECTRONICS

Buy 10 x £1 Special Packs and choose another one FREE

SP1 15 x 5mm Red Leds	SP131 2 x TL071 Op-amps
SP2 12 x 5mm Green Leds	SP133 20 x 1N4004 diodes
SP3 12 x 5mm Yellow Leds	SP134 15 x 1N4007 diodes
SP5 20 x 5mm 1 part Led clips	SP135 5 x Miniature slide switches
SP6 15 x 3mm Red Leds	SP137 4 x W005 1.5A bridge rectifiers
SP7 12 x 3mm Green Leds	SP138 20 x 2.2/63V radial elect caps
SP8 10 x 3mm Yellow Leds	SP142 2 x Cmos 4017
SP9 20 x 3mm 1 part Led clips	SP143 5 Pairs min. croc.clips (Red+Blk)
SP10 100 x 1N4148 diodes	SP144 5 Pairs min. croc.clips (assorted colours)
SP11 30 x 1N4001 diodes	SP146 10 x 2N3704 transistors
SP12 30 x 1N4002 diodes	SP151 4 x 8mm Red Leds
SP18 20 x BC182B transistors	SP152 4 x 8mm Green Leds
SP20 20 x BC184B transistors	SP153 4 x 8mm Yellow Leds
SP23 20 x BC549B transistors	SP154 15 x BC548B transistors
SP24 4 x Cmos 4001	SP155 6 x 1000/16V radial elect. caps
SP25 4 x 555 timers	SP160 10 x 2N3904 transistors
SP26 4 x 741 Op-amps	SP161 10 x 2N3906 transistors
SP28 4 x Cmos 4011	SP164 2 x C106D thyristors
SP29 4 x Cmos 4013	SP165 2 x LF351 Op-amps
SP33 4 x Cmos 4081	SP166 20 x 1N4003 diodes
SP34 20 x 1N914 diodes	SP167 5 x BC107 transistors
SP36 25 x 10/25V radial elect caps	SP168 5 x BC108 transistors
SP37 12 x 100/35V radial elect caps	SP172 3 x Standard slide switches
SP38 15 x 47/25V radial elect caps	SP173 10 x 220/25V radial elect caps
SP39 10 x 470/16V radial elect caps	SP174 20 x 22/25V radial elect caps
SP40 15 x BC237 transistors	SP175 20 x 1/63V radial elect caps
SP41 20 x Mixed transistors	SP177 8 x 1A 20mm quick blow fuses
SP42 200 x Mixed 0.25W CF resistors	SP178 8 x 2A 20mm quick blow fuses
SP47 5 x Min. PB switches	SP181 5 x Phono plugs - assorted colours
SP49 4 x 4 metres stranded core wire	SP182 20 x 4.7/63V radial elect caps
SP102 20 x 8 pin DIL sockets	SP183 20 x BC547B transistors
SP103 15 x 14 pin DIL sockets	SP186 6 x 1M horizontal trim pots
SP104 15 x 16 pin DIL sockets	SP192 3 x Cmos 4066
SP109 15 x BC557B transistors	SP195 3 x 10mm Yellow Leds
SP112 4 x Cmos 4093	SP197 6 x 20 pin DIL sockets
SP115 3 x 10mm Red Leds	SP198 5 x 24 pin DIL sockets
SP116 3 x 10mm Green Leds	SP199 4 x 2.5mm mono jack plugs
SP118 2 x Cmos 4047	SP200 4 x 2.5mm mono jack sockets
SP124 20 x Assorted ceramic disc caps	
SP130 100 x Mixed 0.5W CF resistors	

RESISTOR PACKS - C.Film

RP3 5 each value - total 365 - 0.25W	£3.65
RP7 10 each value - total 730 - 0.25W	£4.95
RP10 1000 popular values - 0.25W	£7.00
RP4 5 each value - total 305 - 0.5W	£4.65
RP8 10 each value - total 610 - 0.5W	£7.40
RP11 1000 popular values - 0.5W	£10.15

Catalogue £1.25 inc. P&P or FREE with first order.

P&P £2.50 per order. NO VAT
Cheques and Postal Orders to:

Sherwood Electronics,
10 NEWSTEAD STREET,
MANSFIELD, NOTTS.
NG19 6JJ

PicoScope[®]

PC-OSCILLOSCOPES

PicoScope 3204,5,6 MSO



NEW

2 Analogue, 16 Digital Channels
+ AWG
60, 100 or 250 MHz Bandwidth
200 MS/s Sampling
8 bits Resolution (12 bits enhanced)
8, 32 or 128 MS Buffer memory
Price from £649 \$1070 €785

PicoScope 3400 Series



NEW

4 Channels + EXT and AWG
60 to 200 MHz Bandwidth
1 GS/s Sampling
8 bits Resolution (12 bits enhanced)
4 to 128 MS Buffer memory
Price from £599 \$988 €725

PicoScope 6400 Series



UPDATED
2012

4 + External trigger and AWG or
Func. Generator
250 to 500 MHz Bandwidth
5 GS/s Sampling
8 bits Resolution (12 bits enhanced)
128 MS to 1 GS Buffer memory
Price from £1995 \$3300 €24202

ALL MODELS INCLUDE ADVANCED DIGITAL TRIGGERS, SERIAL DECODING
(I²C, SPI, RS232, CAN, LIN, FLEXRAY) MASK LIMIT TESTS, SEGMENTED MEMORY,
DIGITAL FILTERING, FREE SOFTWARE UPDATES AND 5 YEAR WARRANTY

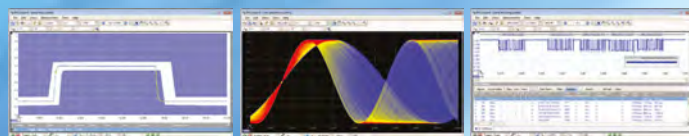

www.picotech.com/PS197

Impersonate a robot,
a droid or one of
the many known
interplanetary aliens such
as Daleks, Cybermen,
Klingons, Cylons or even
Darth Vader... build this

Interplanetary Voice

By John (call me ET) Clarke

... and never be caught out,
out of your galaxy. . . again!

Be sure to blend in among diabolical characters at your next interplanetary meeting. By building the Interplanetary Voice you too can sound like a genuine alien character with a metallic voice. Use it to develop instant rapport with any alien horror that you meet!



If you don't want to cause a *faux pas* of interplanetary proportions (perhaps even threatening life on Earth as we know it), having a correct sounding voice is a prerequisite if you are communicating with one of the myriad of science-fiction characters that originate from distant planets. Many of these characters are encapsulated in a metallic suit, and not surprisingly have a metallic sounding voice.

It is not uncommon for people on planet Earth to be aware of interplanetary aliens. They will know of the Daleks who originate from the planet Skaro and the Cybermen from Mondas. These characters are often portrayed in the TV series *Dr Who*.

Undoubtedly, many will have heard the terrifying and menacing phrase from the Daleks as they call out 'Exterminate!, Exterminate!'. Indeed, for some, it may well be the very last thing they hear.

Other characters well known to the general public on planet Earth include: the Klingons from *Star Trek*, the Cylons from *Battlestar Galactica* and Darth Vader from *Star Wars*.

We will surely be exposed to more characters of this type as we come to explore more planets in the galaxy and beyond.

One unfortunate characteristic of humans from the planet Earth is that they do not have the right sounding voice. Because of this, they are unable to communicate effectively with these interplanetary characters.

You really require a voice changer to convert a normally boring humanoid voice into a strongly metallic version. In this way, your voice can be well understood with all manner of creatures you may encounter from other planets.



In the past, we assisted you with voice modification by producing the *Galactic Voice* project, which was published in July 2008 and now we have (drum roll, if you please!) *Interplanetary Voice*.

So, how is this project special? *Interplanetary Voice* is unique. It stands out as superior to other projects because instead of generating sounds with non-specialised integrated circuits (ICs), it uses a dedicated voice changer IC, which produces a variety of magnificent, extraterrestrial metallic voice sounds.

Yes, we know you can buy these on eBay . . .

We're not saying that's where the idea came from (hey, they might have got their idea from us!) but these types of devices are quite commonly available.

The one shown here (from China, naturally) was purchased on eBay for about £20 which is less than the parts cost for our version.

(We don't know which chip they've used 'cos they've 'blobbed' it over!)

But we think ours is better – for a start, only about half the switch positions on the commercial one appear to do anything – and while it has some snazzy LEDs which flash around the speaker when you're talking, it's a little-known fact that most interplanetary aliens would find flashing lights the height of rudeness and very, very insulting – and they may well reduce you to a pile of ash in retaliation!



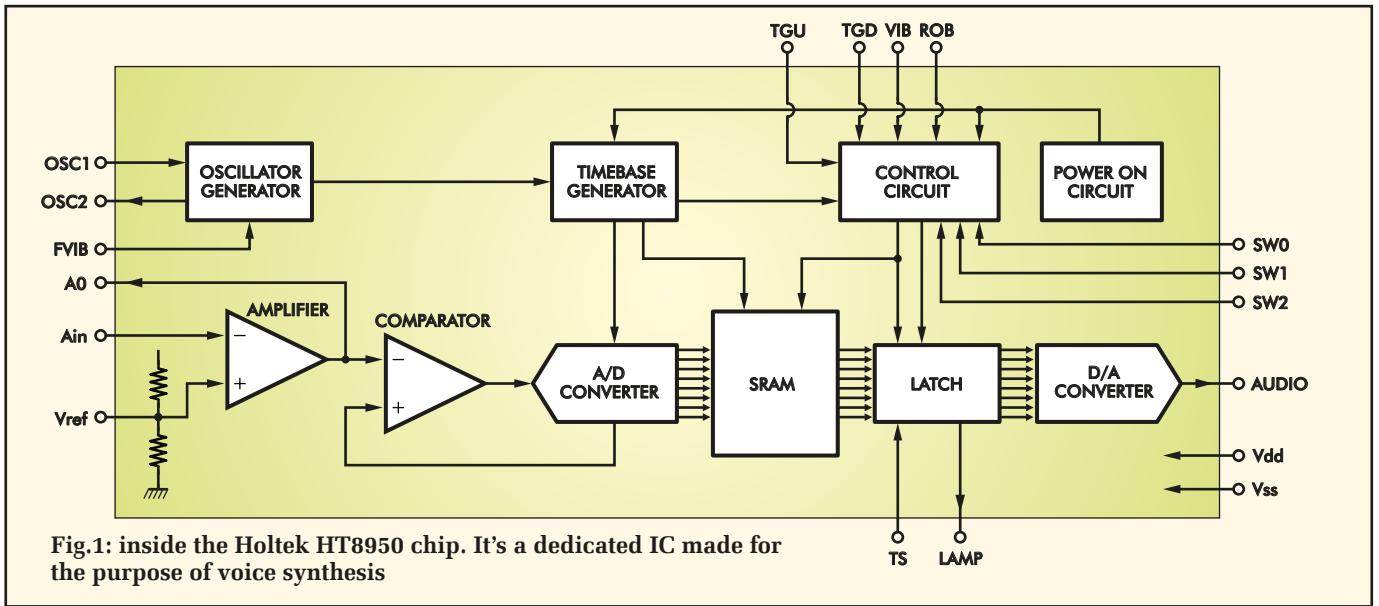

Fig.1: inside the Holtek HT8950 chip. It's a dedicated IC made for the purpose of voice synthesis

Voice changer

Undoubtedly, aliens from other planets use a similar voice changer IC. As we know, most ICs on planet Earth use a silicon-based semiconductor material, but we suspect that the voice changer IC used by aliens is based on a semiconductor that differs from silicon.

Not to worry though, because the silicon version of the voice changer does the job just as well as any of the alien versions; in fact, without evidence to the contrary, it could be better.

Interplanetary Voice is made in such a way that all you need to do is speak into it with a normal voice. It will do the conversion for you, producing a metallicly accented sound via an output loudspeaker.

Unique housing

The *Interplanetary Voice* PCB is housed in a unique interplanetary-style 'mouthpiece'. If you are

from Earth, you'll note it has a decided similarity to a flared loudspeaker port – this is purely coincidental.

At the flared end is a small sound-producing device – again, earthlings may think this resembles a small speaker. The flare projects sound directly to an interplanetary alien's earpiece. Additionally, the flare and loudspeaker grill will imitate many a metallic-voiced character's mouthpiece, so you won't be mistaken for an earthling.

The various controls and the microphone are mounted at the opposite end of the loudspeaker port. You can alter the volume with a rotary control and use pushbutton switches to set the voice effects, depending on the characteristic sound you need.

There are 'robot', 'vibrato' and 'effects' selections available. A power switch is included as well as an LED indicator. Additionally, an LED varies

in brightness to show the instantaneous volume level of your voice.

Block diagram

The voice changer device used in the *Interplanetary Voice* is a Holtek Semiconductor Incorporated IC, designated the HT8950. This is fortunately available on planet Earth, though it does come from the alien land of Taiwan.

The internal arrangement for the HT8950 IC is shown in Fig.1. Voice signal input is applied to the op amp. This has its non-inverting (+) input tied to a reference voltage, allowing signals to swing above and below the reference. Both the inverting input and output of the op amp are available at the IC pins, so that the op amp can be set up as an amplifier.

The signal from the op amp is converted to a digital value using an 8-bit analogue-to-digital converter. An oscillator and timebase generator set

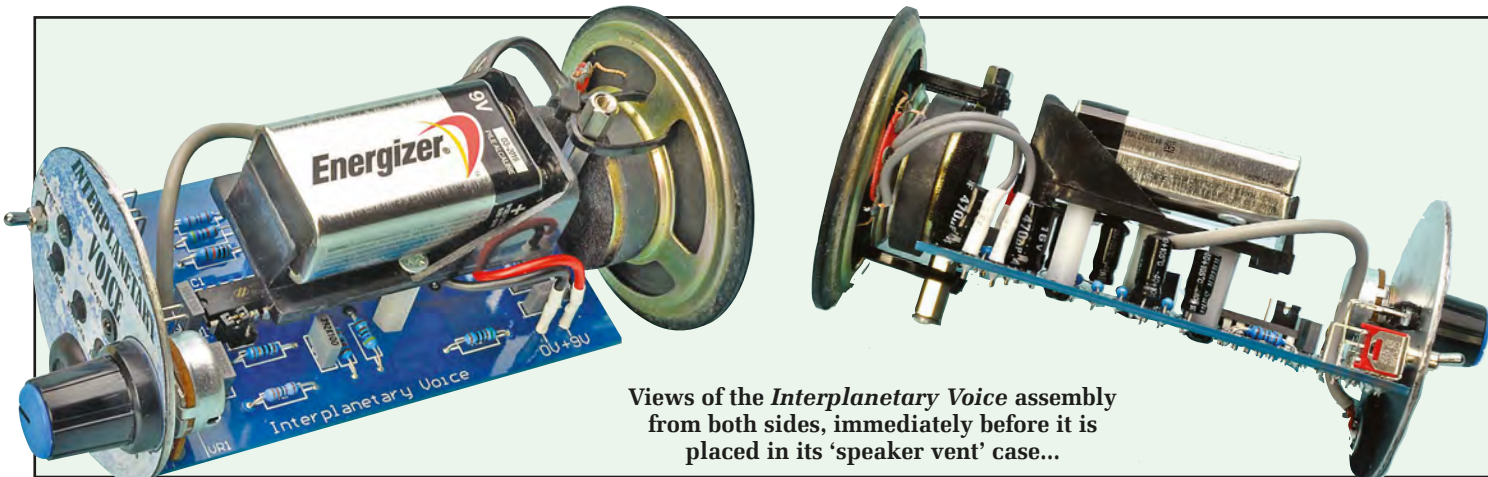

Views of the *Interplanetary Voice* assembly from both sides, immediately before it is placed in its 'speaker vent' case...

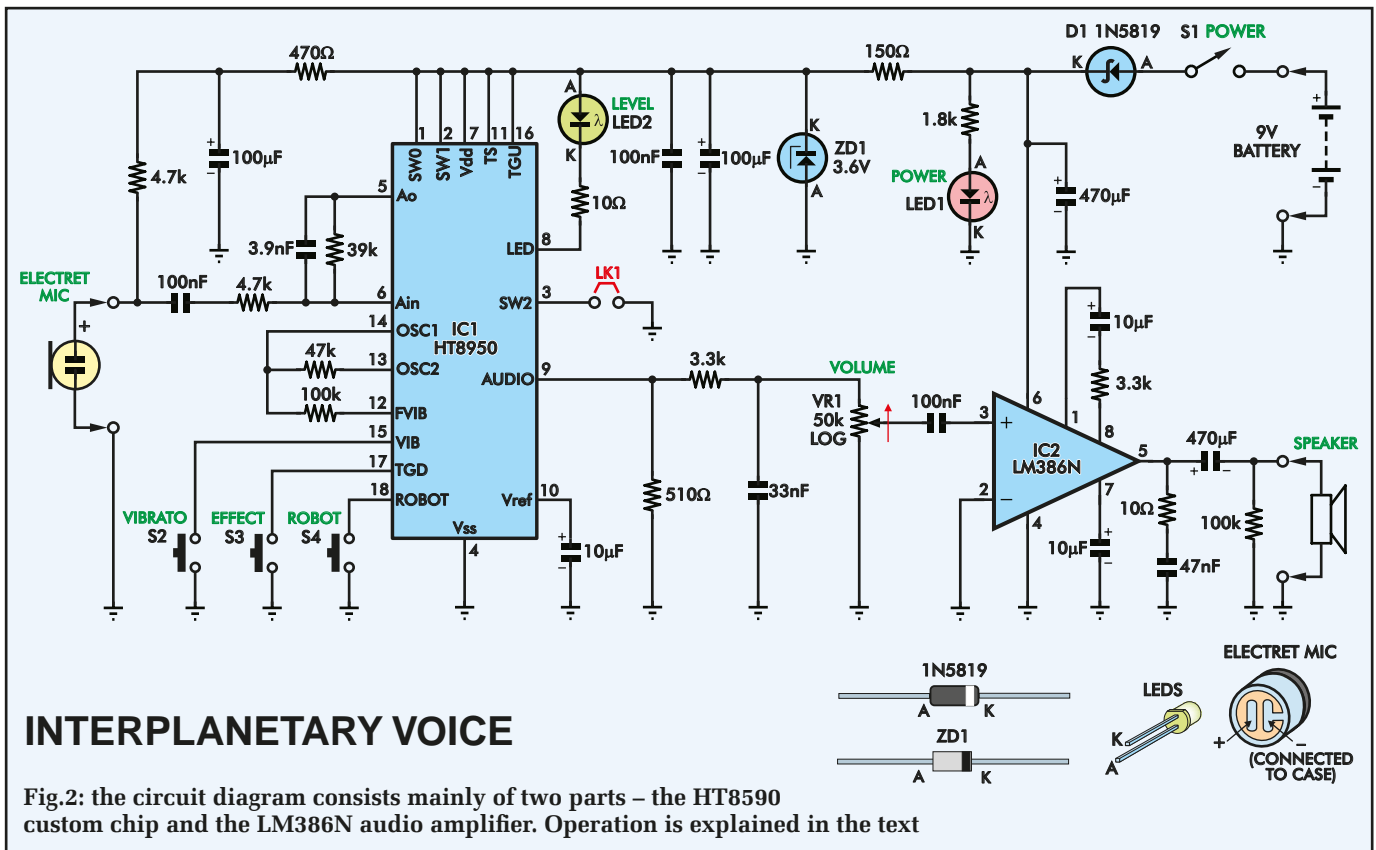

this analogue-to-digital conversion sampling rate to 8kHz. The timebase also sets the storage rate of the digital conversion values into the static RAM. The latch presents and holds the SRAM values as they are clocked out, and the digital-to-analogue converter reconstructs the digital data to an analogue signal.

An external low-pass filter removes the higher frequency components from the digital-to-analogue signal.

There is no information about the signal processing used to produce the voice changing. We do know that the input signal can be frequency

modulated at 8Hz when Vibrato is selected on the Voice. The Robot selection on the *Interplanetary Voice* appears to produce a ring modulator effect, where the input voice signal is multiplied by another frequency (derived from the timebase generator) to produce sum and difference frequencies. This causes an upward or downward frequency shift of the input signal, plus a shift in the signal harmonics. The modulation results in a metallic sounding timbre.

Inputs to the control circuit allow for variation of the amount that the ring modulation frequency shifts the input

signal. Selection ranges from lower frequency shifts at a factor of 0.888, 0.8 and 0.66 to higher frequency shifts of 1.33, 1.6 and 2. These are selected using the Effects switch on the front control panel.

Circuit description

The full circuit diagram for the *Interplanetary Voice* is shown in Fig.2. It comprises just two ICs; the Holtek HT8950 and an LM386 power amplifier to drive the loudspeaker. The HT8950 requires a 2.4V to 4V supply, while the LM386 can be powered from the 9V supply.



Constructional Project

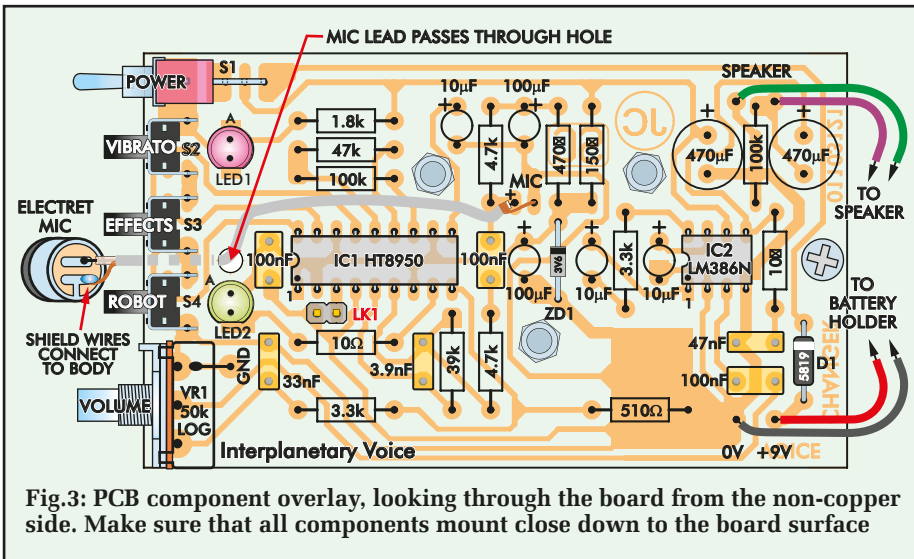

Fig.3: PCB component overlay, looking through the board from the non-copper side. Make sure that all components mount close down to the board surface

The electret microphone is biased from a decoupled supply that uses a 470Ω resistor from the 3.6V supply, bypassed with a 100µF capacitor. A 4.7kΩ resistor provides the electret bias current.

The signal output from the electret microphone is AC-coupled to the op amp within IC1 (pin 6). This amplifier is set up as an inverting amplifier with the 4.7kΩ resistor for the inverting input and the 39kΩ resistor providing the feedback from the op amp output. The gain is about 8.3 and the signal is rolled off above 1.046kHz using a 3.9nF capacitor across the 39kΩ resistor. Below 338Hz, the signal is rolled off due to the 100nF capacitor and 4.7kΩ input impedance.

An internal oscillator for IC1 is set up by the 47kΩ and 100kΩ resistors at

oscillator pins 13 and 12 respectively. Internal capacitance sets the frequency at 640kHz.

Control pins

Control inputs for IC1 are at pin 1 to pin 3, and from pin 15 to pin 18. Only pins 3, 15, 17 and 18 are used in our circuit. The unused pins can be left open due to internal pull-up resistors at each input, but we tied these high to 3.6V on the PCB.

Pins 15, 17 and 18 can be momentarily connected to ground using push-button switches S2 to S4. These set the Vibrato, Effects and Robot functions respectively.

Vibrato is toggled on or off with each press of switch S2. Pressing switch S3 cycles through the available frequency

shift options for the modulator effects. Robot sound is selected with S4. It is deselected whenever there is a pressing of S3 to return to Effects mode. Vibrato can be selected as on or off in the Robot mode and effects mode.

Tying pin 3 low using link LK1 sets a normal sounding voice effect. This is regardless of the selections made with switches S2 to S4.

An LED driver at pin 8 provides a variable brightness indicator of the signal level received at the microphone. The LED modulates in brightness as you speak into the microphone.

Output

The output at pin 9 is an open-drain connection (from the internal P-channel output MOSFET). A suitable drain load is provided by a 510Ω resistor connected to ground. The signal is filtered using a passive low-pass filter comprising a 3.3kΩ resistor and a 33nF capacitor. The high-frequency roll-off is above 1.5kHz. Volume control is provided by VR1, a 50kΩ logarithmic potentiometer.

The signal from the wiper (moving contact) of VR1 is AC-coupled (100nF) to IC2, the audio power amplifier, at pin 3. The inverting input of the power amplifier at pin 2 is grounded.

IC2 has a gain of close to 27, as set by the 3.3kΩ resistor and series 10µF electrolytic capacitor between pin 1 and pin 8. The power supply is bypassed with a 470µF capacitor, and the separate 10µF supply bypass at

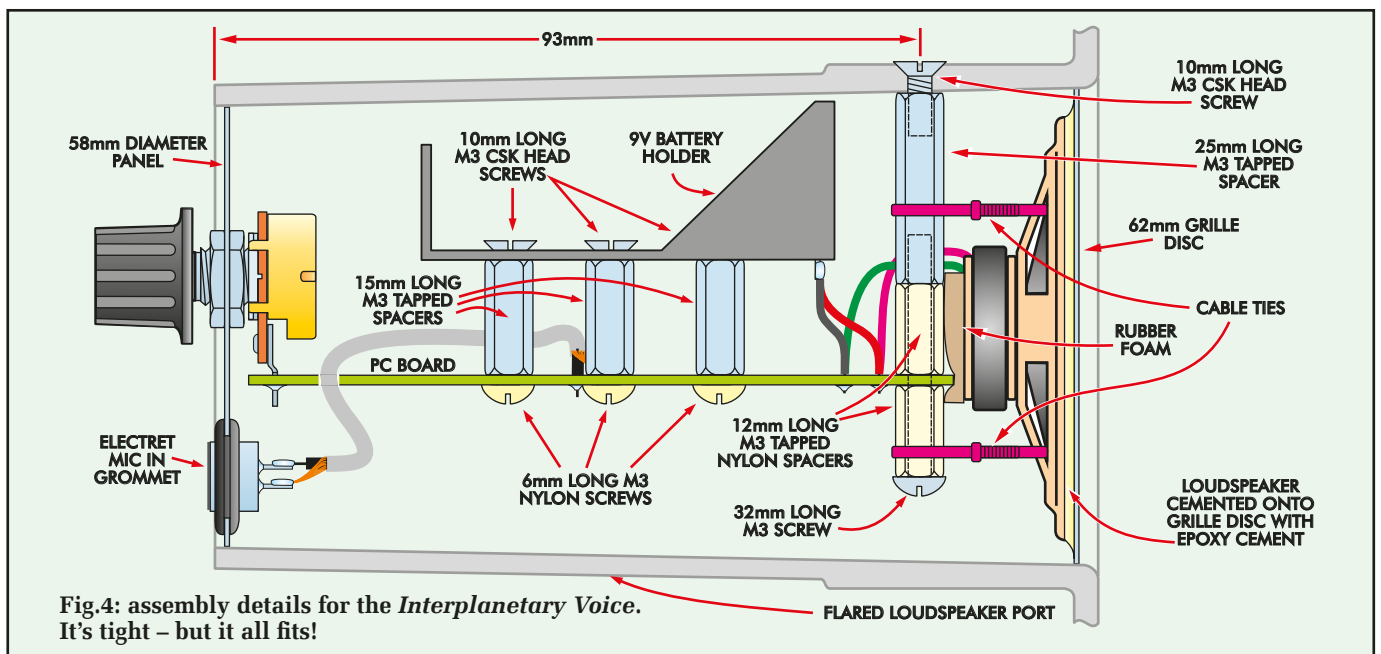

Fig.4: assembly details for the Interplanetary Voice. It's tight – but it all fits!

pin 7 removes supply ripple from the amplifier input stages.

A Zobel network comprising a 10Ω resistor and 47nF capacitor prevents amplifier instability. The output of the amplifier drives the loudspeaker via a 470μF capacitor. The capacitor provides low frequency roll-off below 42Hz for the 8Ω load.

Audio amp IC2 can provide about 600mW into 8Ω with a 9V supply at 3% THD. Typical distortion is less than 0.2% below 200mW.

Power for the circuit is derived from a 9V battery, via power switch S1. Diode D1 prevents damage to the circuit with reversed supply. The low forward-voltage drop of this Schottky diode gives extended battery life compared to using a standard diode.

The supply for IC1 is regulated using a 3.6V Zener diode (ZD1) and a 150Ω resistor. The resulting 3.6V rail is bypassed with a 100nF capacitor and a 100μF electrolytic capacitor.

Construction

The *Interplanetary Voice* is constructed on a smallish (92mm × 54mm) PCB code 892, is available from the *EPE PCB Service*. The circuit board component layout is shown in Fig.3.

This PCB is suspended within the plastic loudspeaker port and is supported at one end with the circular front panel that fits into the non-flared end of the port. The opposite end of the PCB is supported using a long standoff that is secured to the flared end of the plastic speaker port (see Fig.4).

Start construction by checking the board for breaks in copper tracks or shorts between tracks or pads. It's unlikely that you will find any faults, but it's best to check before installing any parts.

Board assembly

Assembly can now begin by inserting the resistors. Use the resistor colour code table (Table 1) as an aid to reading the resistor values. A digital multimeter can also be used to measure each value. The two diodes (D1 and ZD1) can now be installed, and these must be mounted with the orientation as shown. Install the five PC stakes.

Two 2-way headers are used, one for link LK1 and the other as terminals to connect the electret microphone. Unless you want a normal sounding voice

Parts List – Interplanetary Voice

1 PCB, code, 892, 92mm × 54mm, available from the <i>EPE PCB Service</i>	1 100mm length of single core screened cable
1 panel label, 58mm in diameter	1 50mm length of light duty figure-8 wire
1 flared speaker box port, 58mm diameter × 120mm long	1 50mm length of red hookup wire
1 8Ω loudspeaker, 57mm-diameter	1 50mm length of black hookup wire
1 electret microphone insert, 9.5mm diameter	
1 62mm diameter × 1mm aluminium or fibreglass disc for speaker grille	Semiconductors
1 58mm diameter × 1mm aluminium or fibreglass disc for front panel	1 HT8950 (18-DIP version) Voice Modulator (IC1) (DO NOT use the 16-pin HT8950A, it has different pinouts to the HT8950) Available from eBay
1 rubber grommet with 9.5mm ID hole	1 LM386N audio amplifier (IC2)
1 9V PCB-mount batteryholder	1 3.6V 400mW Zener diode (ZD1)
1 9V alkaline battery	1 1N5819 1A Schottky diode (D1)
1 potentiometer knob	1 3mm red LED (LED1)
1 SPDT PCB mount toggle switch (S1)	1 3mm green LED (LED2)
3 right-angle tactile pushbutton PCB switches with 3.5mm actuator (S2 to S4)	Capacitors
1 8-pin IC socket (optional)	2 470μF 16V PC electrolytic
1 18-pin IC socket (optional)	2 100μF 16V PC electrolytic
2 3mm LED bezels	3 10μF 16V PC electrolytic
3 15mm M3 tapped spacers	3 100nF MKT polyester
2 12mm M3 tapped spacers (or 1 25mm M3 tapped spacer cut to 2 × 12mm)	1 47nF MKT polyester
1 25mm M3 tapped spacer	1 33nF MKT polyester
1 M3 × 32mm screw	1 3.9nF MKT polyester
1 M3 × 10mm pan head or countersunk screw	Resistors
3 M3 × 6mm screws	2 100kΩ 1 1.8kΩ
3 M3 × 6mm countersunk screws	1 47kΩ 1 510Ω
2 2-way pin headers (2.54mm spacing)	1 39kΩ 1 470Ω
1 jumper shunt	2 4.7kΩ 1 150Ω
2 100mm cable ties	2 3.3kΩ 2 10Ω
1 20-30mm diameter piece of thin rubber foam (eg, opened out earphone pads)	1 50kΩ 16mm log pot (VR1)
5 PC stakes	Miscellaneous
	Silicone sealant, solder, heatshrink tubing
	Handle
	1 90mm × 110mm × 19mm solid timber (shaped for a handle)
	2 cheese head wood screws 12mm long

from the *Interplanetary Voice*, the LK1 jumper should be left off.

IC1 and IC2 can be mounted using sockets, although this is not strictly necessary and the ICs can be directly soldered to the PCB. When installing the sockets (if used) and the ICs, take care to orient these correctly, ie, with the notch or dot adjacent to pin 1 at one end – positioned, as shown in Fig.3.

The capacitors can now be mounted. The electrolytic types must be oriented with the shown polarity. Keep the height of the electrolytic capacitors below 14mm, to provide clearance for the batteryholder that mounts on 15mm spacers over the PCB.

Next, cut the potentiometer shaft to 12mm long, and remove the locating spigot at the side of the body adjacent to the mounting thread. This is easily

Constructional Project

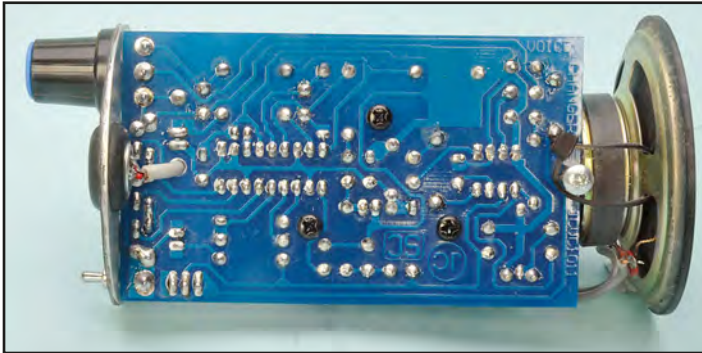

(Above): a view of the back of the PCB, showing how it and the other hardware is assembled before insertion in the 'case'. At right is a close-up of the front end of the PCB with the various 'front panel' controls

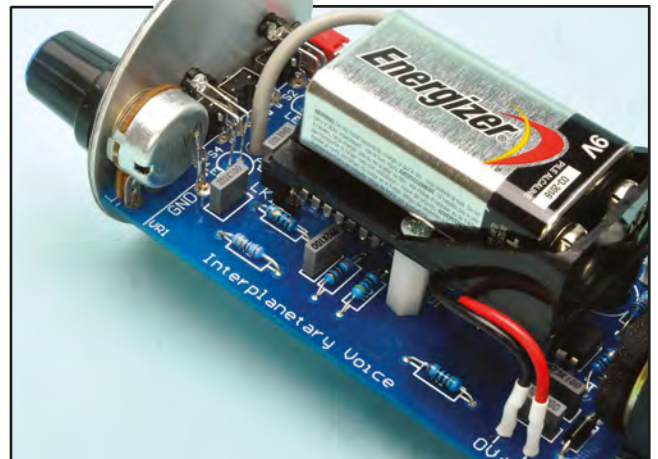

snapped off with pliers. That done, install potentiometer (log) VR1 and switches S1 to S4. VR1 should be connected (soldered) to the GND PC stake using a short length of tinned copper wire. An offcut from a resistor lead will be suitable.

It is usually necessary to scrape away some of the coating on the pot body before soldering to the back of the pot, otherwise the solder will not adhere.

LED1 and LED2 mount horizontally, but at a height of 13mm above the PCB. First, bend the leads at 10mm back from the base of each LED at right angles, making sure the anode (A) lead is oriented toward S1, as shown on the overlay diagram in Fig.3.

Front panel

The panel label for this project can be downloaded from the *EPE* website (www.epemag.com). This file also contains a drilling guide for both the control panel and the loudspeaker grille. When downloaded, you can print the drilling guide on to paper.

Drill the panels as shown on the drilling guide (see also Fig.5). Be sure to remove the swarf from the edges of the holes with a larger drill or counter-sinking drill.

The front-panel label can be printed on to sticky-backed photopaper or plastic film. When using clear plastic film (overhead projector film), you can print the label as a mirror image so that the ink is behind the film when placed on to the panel.

Once the ink is dry, cut the label to size. The paper or plastic film is affixed to the panel using an even smear of neutral-cure silicone. The holes in the label can be cut with a sharp hobby knife or a leather punch.

Installation

Fig.4 shows the assembly details for the *Interplanetary Voice*.

The electret microphone is mounted inside a rubber grommet attached to the front panel (below the PCB) and is connected via a length of shielded cable. This cable passes through a hole near LED2 on the PCB. Make sure the 'earth' side of the electret connects to the shield. The shield at the other end of the screen cable connects to the earth pin on the PCB, as shown for the electret wiring.

The 9V battery holder is secured to the PCB using M3 × 15mm tapped standoffs. The three mounting holes in the battery holder are drilled out to 3mm

to accommodate the M3 screws. In doing this, the original underside bushes at these battery-holder mounting points are removed and the holes cleaned up with a larger drill. This will allow the battery holder to sit closer to the PCB.

Bend the connecting pins on the holder backwards under the battery holder and solder leads to connect to the supply PC stakes on the PCB. M3 machine screws secure the standoffs to the PCB, while M3 countersunk screws are used for the battery holder.

The rear mounting point on the PCB utilises two 12mm-long standoffs and one 25mm-long standoff. Cutting a 25mm standoff in half can make up the 12mm standoffs required (or use separate 12mm standoffs). These are secured to the PCB using M3 × 32mm screws.

The screw is first screwed into a 12mm standoff and the remaining screw thread section is inserted into the PCB from the underside and then screwed into the second 12mm standoff. The 25mm standoff is then screwed on to the remainder of the screw thread. The 25mm standoff is secured to the speaker port with an M3 × 10mm screw.

Table: Resistor Colour Codes

	No.	Value	4-Band Code (1%)	5-Band Code (1%)
□	2	100kΩ	brown black yellow brown	brown black black orange brown
□	1	47kΩ	yellow violet orange brown	yellow violet black red brown
□	1	39kΩ	orange white orange brown	orange white black red brown
□	2	4.7kΩ	yellow violet red brown	yellow violet black brown brown
□	2	3.3kΩ	orange orange red brown	orange orange black brown brown
□	1	1.8kΩ	brown grey red brown	brown grey black brown brown
□	1	510Ω	green brown brown brown	green brown black black brown
□	1	470Ω	yellow violet brown brown	yellow violet black black brown
□	1	150Ω	brown green brown brown	brown green black black brown
□	2	10Ω	brown black black brown	brown black black gold brown

The front panel is secured to the PCB using the potentiometer nut. The LEDs are secured with 3mm LED bezels, while switches S1 to S4 simply protrude through the panel holes.

The speaker is glued to the grille disc. We used silicone sealant, but many alternative types of glue can be used instead. When the glue or sealant is dry, solder the figure-8 wire to the speaker terminals and the PC stakes on the PCB.

The speaker is supported using cable ties that wrap through the speaker frame and around the standoffs. A 30mm-diameter piece of thin rubber foam is affixed to the back of the speaker magnet to help keep the speaker in place.

The speaker should be positioned so that it is centred within the speaker port flare (ie, when it is assembled into the speaker port with the 25mm standoff located up against the top inside of the speaker port).

A 3mm hole is required in the top of the speaker port flare to accept an M3 countersunk screw to secure the 25mm standoff. This is located 93mm from the non-flared port end – see Fig.4.

Note that a series of holes should be drilled into the speaker port to prevent the port acting as a tuned pipe. Without the holes, there will be sufficient resonance for feedback from the speaker to the microphone, causing a howling noise. This would occur with only moderate volume settings for at least two of the effects selections on the *Interplanetary Voice*.

As shown in the photos, the holes are arranged as a row of eight 5mm-diameter holes distributed along the length of the port and repeated at 45° intervals around the diameter. That's 64 holes in total.

Hand grasp

A handle was fashioned from an offcut piece of timber and secured to the underside of the speaker port with two wood screws. The screw heads are raised above the timber by 2mm (ie, the speaker port thickness). The shape of the handle isn't critical as long as it is comfortable to hold. The handle can be finished with black paint or stain.

Two holes are drilled in the underside of the speaker port, large enough to accept the head of each screw. Then slots are filed from each hole toward the flared end, just wide enough for the screw, but not for the screw head. Inserting the two screw heads into the

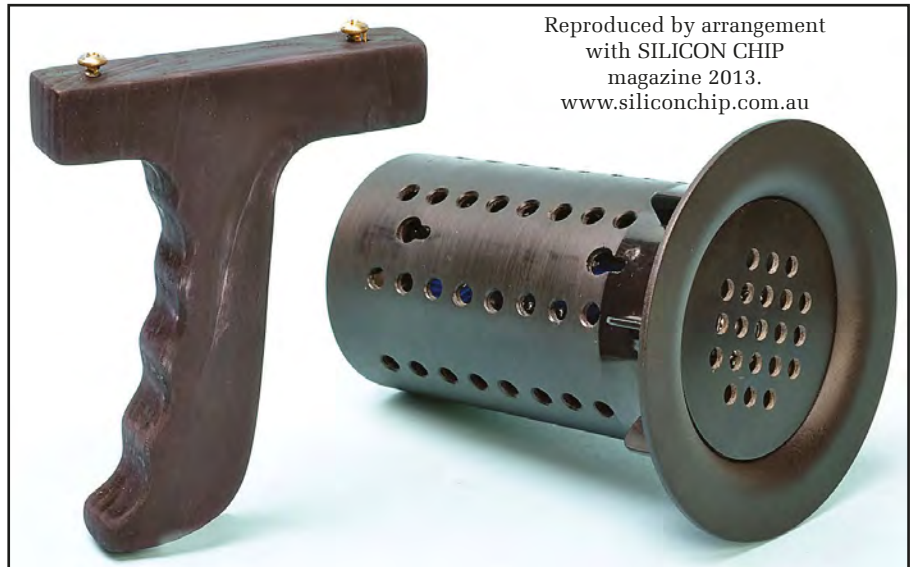

Reproduced by arrangement with SILICON CHIP magazine 2013.
www.siliconchip.com.au

Here's the handle we made – it mates with the two 'keyholes' in the *Interplanetary Voice* case. Note also the drilling required in the case

holes and pushing forward so that the screws engage the slots attaches the handle. Removal is the reverse procedure, ie, by pulling back the handle so that the screw heads can be removed from the holes. The handle will need to be removed both to insert and to remove the *Interplanetary Voice* assembly within the speaker port.

Testing

Insert the 9V battery and switch on the *Interplanetary Voice* with the power switch (S1). Power LED (LED1) should light. If not, check the LED's polarity.

Next, measure the voltage between the GND PC stake behind VR1 and the cathode (K) of ZD1. This should be around 3.6V, although anywhere between 3.3V and 3.9V is acceptable. Speaking into the microphone should produce sound from the loudspeaker, with suitable level set by the volume control. LED2 should vary in brightness with voice volume.

When power is first applied to the *Interplanetary Voice*, the voice effect is set for Robot. Pressing the Effects switch will change the sound from Robot and you can cycle through seven different effects with each switch press. Robot voice is selected at any time, again with the Robot switch.

Pressing the Vibrato switch will add vibrato to the sound; pressing the vibrato switch again will deselect Vibrato. Adjust the volume control for the best *Interplanetary Voice* effect.

Note that excessive volume may ultimately produce feedback between the speaker and microphone, particularly with the Robot voice selection.

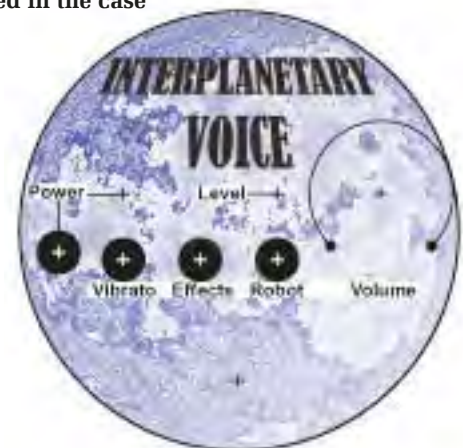

Fig.5: here's the 'front panel' label which also serves as a drilling template. This can be downloaded from the *EPE* website

Generally, the volume is best adjusted to prevent feedback, but for added effects, set the volume just at the threshold of continuous feedback. This tends to make the voice ring for a short period.

Quiescent current consumption for the *Interplanetary Voice* is about 40mA. More current is drawn from the battery as the *Voice* delivers sound. Be sure to switch off the power after use, because the 9V battery won't last long otherwise.

Note that if you are not imitating a metallic voice sound, then LK1 can be shorted with a jumper shunt for a normal voice sound from the *Interplanetary Voice*. That will allow you to speak to humans using their own style of voice.

Alternatively, for normal voice, the *Interplanetary Voice* can be dispensed with altogether and you can use your vocal cords totally unaided. But doing this, you run the risk of being discovered as human rather than alien. **EPE**



Max's Cool Beans

By Max The Magnificent

The concept of the Internet of Things (IoT) was first discussed by Kevin Ashton in 1999. Although different people may have their own interpretations, the IoT is now generally understood to refer to the idea of having uniquely identifiable objects, along with their virtual representations, accessible and controllable using an Internet-like structure. Apart from anything else, this requires that anything we decide to connect into the network – ranging from individual light bulbs to the most complex of systems – has a unique address.

Grains of sand

Can we really support unique addresses for every electrical/electronic item – like each and every light bulb – on the planet? Well, the latest version of the Internet Protocol (IPv6), which is currently in the process of being deployed, uses 128-bit (16-byte) addresses, so the new address space supports 2^{128} (approximately 340 undecillion or 3.4×10^{38}) addresses.

According to calculations and estimations performed at the University of Hawaii (who obviously have far too much time on their hands), all of the beaches on planet Earth contain around 7.5×10^{18} grains of sand. Thus, the addressing space of IPv6 is sufficient to give each grain of sand its own unique IP address – and to do this for approximately 5×10^{19} Earthlike worlds! On this basis, I don't think we're going to run out of Internet addresses in the foreseeable future.

Wireless mesh networked propeller beanie hats

Now, there are all sorts of ideas bouncing around for different IoT applications, but I wanted to do something a little different. As I may have mentioned in a previous column, I've formed a club called the Worshipful Ancient Order of Froth Blowers (WAOFB) and since it's my club, I've elected myself as the supreme worldwide commander, which looks very impressive on my business cards. As supreme commander, I took it upon myself to decide on the official headgear for the club (I'm still working on the secret handshake), and I eventually opted for the propeller beanie, because I thought this would convey the right amount of gravitas on the members of our august body.

You can only imagine my surprise when I received an email containing a picture showing a local chapter meeting in a pub, all sporting their propeller beanies. The reason the propellers appear a little blurred in this image is that these sterling fellows have added motors to their beanies.



Well, I have to give them 'ten points for effort,' but this spurred me on to greater things. As you may recall, I'm the editor in chief for the All Programmable Planet (APP) website (www.AllProgrammablePlanet.com). By some

strange quirk of fate, the official headgear for APP is also the propeller beanie (hey, I already had one in my office, so it was a case of 'two birds with one stone').

The idea is that if a number of APP members happen to be attending the same technical conference, and they are all wearing their propeller beanies, then it will be easy for us to spot each other in a crowd. But anyone can wear a propeller beanie – how can we tell one of 'us' from one of 'them'? Well, my friend David Ewing is the chief technical officer (CTO) at Synapse Wireless (www.synapse-wireless.com), a company whose mission it is to provide low-power wireless technology to monitor and control anything from anywhere. When I posed my conundrum to David, he came up with the concept of CapNet™ – a low-power wireless mesh network deployed in propeller beanie hats.

The idea is that the hats will be in constant communication with each other and – by bouncing signals back and forth and measuring response times – the hats will know their locations relative to each other. Thus, as one APP member approaches another APP member, the propellers on their hats will start to spin. The closer they become – and the more hats that are in the local vicinity – the faster the propellers will go round. Actually, I'm very much oversimplifying this, because the hats will be equipped with a variety of different sensors (thermocouples and accelerometers, to name a few) and displays (including a number of flashing LEDs). Furthermore, networks of APP hats at conferences will be able to communicate with networks of WAOFB hats in bars via the 'cloud.' I'm prepared to bet that this is an incarnation of the IoT that has not been conceived by anyone else.

What are the chances...?

Of course, you may ask 'What are the chances of being at a technical conference and running across someone else sporting one of these hats?' Well, you may be surprised to learn that they are, in fact, surprisingly good.

Yours truly happens to be the track chair for 'Processors and Programmable Devices Track' at the forthcoming Design West Conference and Exhibition (www.ubmdesign.com), which is to be held 22-25 April 2013, at the McEnery Convention Center in San Jose, California. As part of this, I invited David to present a paper on the design tradeoffs involved in implementing CapNet; David's paper is titled *Cool Beanies! A Mesh Networked Cranial Cooling System*.

But wait, there's more, because David and other members of the Synapse Wireless team will be giving special one-hour free training sessions on the show floor. This training will show how you can create simple wireless applications in the Python programming language and upload them 'over the air' into wireless nodes. And what better way to demonstrate all of this than to present each student with his or her very own CapNet wireless mesh propeller beanie?

Even better, each beanie comes with a free lifetime membership to APP and the WAOFB. Based on this, I think it's safe to say that by the end of the day I will *not* be the only person at the conference walking around with a propeller beanie on my head (I love it when a plan comes together). Until next time, have a good one!

EPE PIC PROJECTS VOLUME 2 CD-ROM

A plethora of 20 'hand-PICked' PIC projects from selected past issues of *EPE*. Together with the PIC programming software for each project.

The projects are:

BioPIC Heartbeat Monitor

Take a peek at the rhythmic waveforms that keep you ticking

EPE Moodloop

Have a relaxing 'field-day' (or night) with our PIC-based brainwave generator!

EPE Morse Code Reader

Multi-function Morse Code translation and learning aid; standalone plus optional PC interface!

Freebird Glider Control

An automatic flight attitude control system for your free-flight model glider!

IC Tester

Let a PIC and PC check the health of your digital logic chips!

Interior Lamp Delay

Don't you just hate being plunged into darkness when the car door shuts? Here's a solution! Plus lights-on alarm and battery saver!

Multi-Channel Transmission System

An 8 to 16-channel 2-wire PIC-based signalling link, with optional interface for private phone systems!

Musical Sundial

When the sun has got his hat off (hip-hip-hip-hooray) there's no shadow of doubt you'll find fun with our PIC-based musical garden gnomon!

PIC-A-Colour Game

PIC your wits against a colourful code-setting mastermind!

PIC-based Brainbot Buggy

A low-cost, easy-build buggy that has a mind of its own!

PIC-based Fido Pedometer

Keeping track of how far you've walked!

PIC-based Intelligent Garden Lights

An easy-to-build lights controller that knows when it's time to switch off!

PIC-based Remote Control IR Decoder

Allows PIC programming enthusiasts to remotely control their designs!

PIC-based Monitored Dual PSU

Workshop power supply with multiple options and monitoring of voltage and current using a PIC microcontroller plus LCD readout!

PIC Pocket Battleships

Become a Sea Lord with our interpretation of the age-old pen and paper game!

PIC Random LED Flasher

Enjoy the fun of an interesting and attractive pattern display!

PICronos LED Wall Clock

Ancient and modern techniques display timely brilliance on a grand scale!

PIC Virus Zapper MK.2

An alternative method that could keep those bugs at bay!

Time and Date Generator

Add time and date codes to your CCTV security monitor!

Water Monitor

How costly is it to keep your garden watered? Find out and control it!



**ONLY
£14.75**
INCLUDING
VAT and P&P

NOTE: The PDF files on this CD-ROM are suitable to use on any PC with a CD-ROM drive. They require Adobe Acrobat Reader

EPE PIC PROJECTS VOL. 2 CD-ROM ORDER FORM

Please send me (quantity)

EPE PIC PROJECTS VOL 2 CD-ROM

Price £14.75 each – includes postage to anywhere in the world.

Name

Address

.....

.....

..... Post Code

I enclose cheque/P.O./bank draft to the value of £

please charge my Visa/Mastercard/Maestro £

Card No.

Card Security Code

(The last 3 digits on or just under the signature strip)

Valid From Expiry Date

Maestro Issue No.



SEND TO:

Everyday Practical Electronics,

Wimborne Publishing Ltd.,

113 Lynwood Drive, Merley, Wimborne,

Dorset BH21 1UU.

Tel: 01202 880299. Fax: 01202 843233.

Email: orders@epemag.wimborne.co.uk

Payments must be by card or in £ Sterling – cheque or bank draft drawn on a UK bank.

Normally posted within seven days of receipt of order.

Send a copy of this form, or order by letter if you do not wish to cut your issue.

**Order on-line from
www.epemag.com
or by Phone, Fax, Email or Post.**

BECOME A PIC PROJECT BUILDER WITH THE HELP OF EPE!

Jump Start

By Mike and Richard Tooley

Design and build circuit projects dedicated to newcomers, or those following courses taught in schools and colleges.



WELCOME to *Jump Start* – our series of seasonal ‘design and build’ projects for newcomers. *Jump Start* is designed to provide you with a practical introduction to the design and realisation of a variety of simple, but useful, electronic circuits. The series has a seasonal flavour, and is based on simple, easy-build projects that will appeal to newcomers to electronics, as well as those following formal courses taught in schools and colleges.

Each part uses the popular and powerful ‘Circuit Wizard’ software package as a design, simulation and printed circuit board layout tool. For a full introduction to Circuit Wizard, readers should look at our previous *Teach-In series*, which is now available in book form from Wimborne Publishing (see *Direct Book Service* pages in this issue).

Each of our *Jump Start* circuits include the following features:

- **Under the hood** – provides a little gentle theory to support the general principle/theory behind the circuit involved

- **Design notes** – has a brief explanation of the circuit, how it works and reasons for the choice of components
- **Circuit Wizard** – used for circuit diagrams and other artwork. To maximise compatibility, we have provided two different versions of the Circuit Wizard files; one for the education version and one for the standard version (as supplied by *EPE*). In addition, some parts will have additional files for download (for example, templates for laser cutting)
- **Get real** – introduces you to some interesting and often quirky snippets of information that might just help you avoid some pitfalls
- **Take it further** – provides you with suggestions for building the circuit and manufacturing a prototype. As well as basic construction information, we will provide you with ideas for realising your design and making it into a complete project
- **Photo Gallery** – shows how we developed and built each of the projects.

Coming attractions

Issue	Topic	Notes
May 2012 ✓	Moisture alarm	
June 2012 ✓	Quiz machine	Get ready for a British summer!
July 2012 ✓	Battery voltage checker	Revision stop!
August 2012 ✓	Solar mobile phone charger	For all your portable gear
September 2012 ✓	Theft alarm	Away from home/school
October 2012 ✓	Wailing siren, flashing lights	Protect your property!
November 2012 ✓	Frost alarm	Halloween “spooky circuits”
December 2012 ✓	Mini Christmas lights	Beginning of winter
January 2013 ✓	iPod speaker	Christmas
February 2013 ✓	Logic probe	Portable Hi-Fi
March 2013 ✓	DC motor controller	Going digital!
April 2013	Egg Timer	Ideal for all model makers
May 2013	Signal injector	Boil the perfect egg!
June 2013	Simple radio	Where did that signal go?
July 2013	Temperature alarm	Ideal for camping and hiking
		It ain't half hot ...

In this month's *Jump Start* we shall be moving into the world of analogue electronics with a circuit that is ideal for model makers and others needing a means of controlling the speed and direction of small DC motors rated at up to 9V and 500mA.

Under the hood

The simplified block schematic of our *DC Motor Controller* is shown in Fig.1. The circuit provides a means of varying the magnitude and polarity of the voltage and current delivered to a small DC motor fitted to a model, robot or buggy. The input to the *DC Motor Controller* will normally be derived from a hand-held controller fitted with one or more control potentiometers (in applications where more than one motor is to be controlled an individual potentiometer should normally be provided for the control of each motor present).

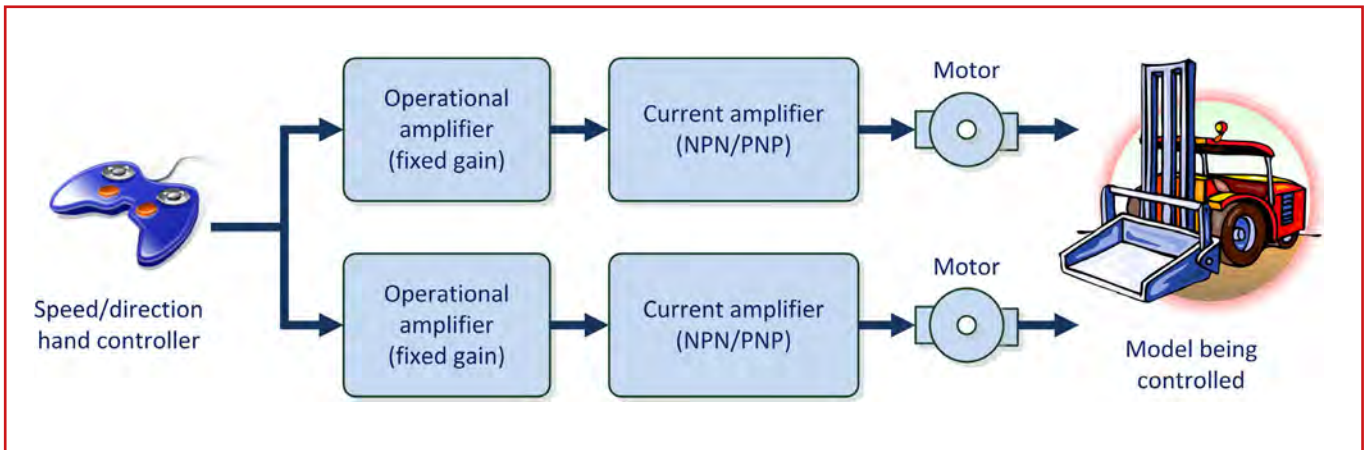

Fig.1. Simplified block schematic of our DC Motor Controller

Our DC Motor Controller uses simple low-cost analogue circuit techniques and, when used with smaller motors, will conveniently operate from a pair of rechargeable PP3 batteries (each providing a nominal 8V output). Rechargeable PP3 batteries are available at reasonable cost from a number of suppliers and can usually be expected to operate satisfactorily for several hundred charge-discharge cycles.

The batteries used with our prototype DC Motor Controller were each rated at 200mAh and so can be expected to operate intermittently for about an hour before needing a recharge. In situations where space is not at a premium and larger motors are fitted, four series-connected AA cells (alkaline or NiMh rechargeable) can replace each of the PP3 batteries with a slightly lower operating voltage.

Design notes

The speed of a DC motor can be controlled by varying the current supplied to it using an arrangement similar to that shown in Fig.2. A medium-power NPN transistor, Q1, provides sufficient current to drive a small motor when supplied with a much smaller current derived from the speed control potentiometer, VR1. The forward-biased silicon diode, D1, sets the minimum value of base current at a value that is just sufficient to bias the transistor into conduction, but not sufficient to cause the motor to rotate. This simple arrangement avoids the ‘dead band’ that would otherwise appear at the bottom end of the control range provided by VR1. With the values shown in Fig.2, our Circuit Wizard arrangement supplies a maximum

of about 160mA to the motor at the maximum speed setting.

A notable disadvantage of the simple speed controller arrangement shown in Fig.2 is that the motor will only rotate in one direction. This problem can be easily overcome by fitting a reversing switch, as shown in Fig.3. The double-pole double-throw (DPDT) reversing switch, SW1, simply reverses the connections to the motor. Unfortunately, a sudden reversal in direction can be undesirable if SW1 is operated when the motor is rotating at speed. Hence, this arrangement suffers from the disadvantage that the reversing switch, SW1, should really only be operated when the motor is stationary (ie, when VR1 is set at its minimum position). A better arrangement would ensure that the motor is stationary before the direction of rotation can be changed.

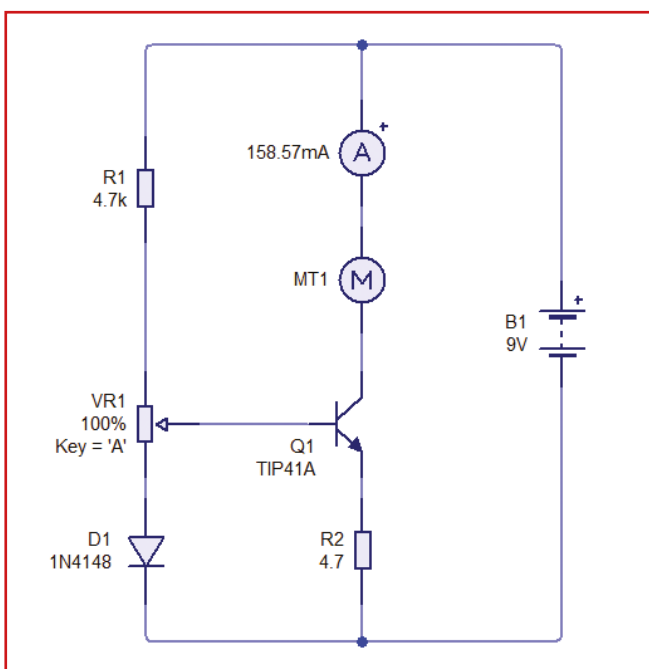

Fig.2. Simple speed controller

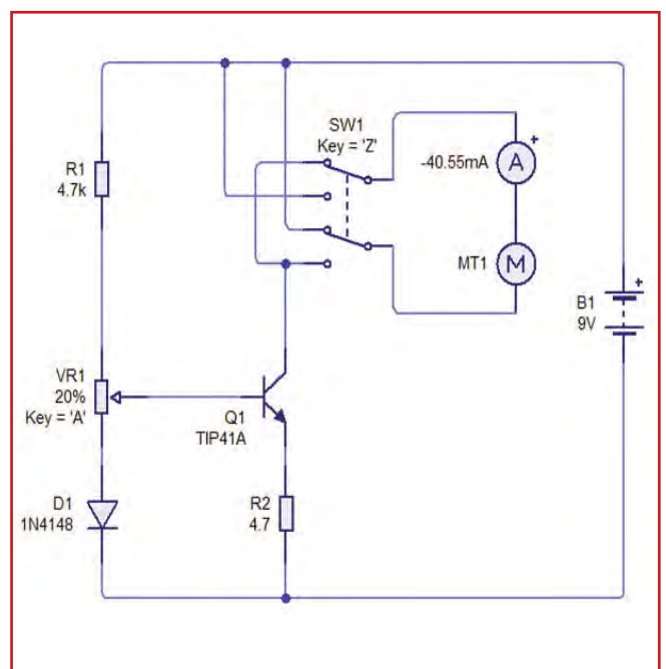

Fig.3. Speed controller with reversing switch

A much improved motor controller in which both speed and direction are controlled by the same potentiometer is shown in Fig.4. With the potentiometer, VR1, set to mid-position the bridge circuit formed by Q1, Q2, B1, and B2 will be balanced, and no current will flow through the motor. If the potentiometer is moved in either direction (away from the centre position) current will flow and the motor will rotate at a speed determined by the amount that the slider has been moved away from the central position. The action of this circuit is such that it ensures that the motor speed always returns to zero before the direction of rotation can be changed.

The complementary symmetrical bridge arrangement shown in Fig.4 is similar to that which we used in our *iPOD Speaker*. Readers requiring a detailed explanation of how this circuit works should refer to January 2013 *EPE*.

Get real

You should now be ready to check the operation of the *DC Motor Controller* for yourself. Fig.5 shows our final design ready to be put through its paces using *Circuit Wizard*. The control potentiometer, VR1, should have a value of 4.7kΩ. We have added two LEDs to the output of the circuit (in parallel with the motor) to provide an indication of the direction of rotation (one LED is red and the other is green). When both LEDs are extinguished the motor will remain stationary. This condition occurs when VR1 is in its central position (shown as 50% in *Circuit Wizard*). Note that we have assigned the control potentiometer to 'A' on the keyboard.

When you have finished experimenting with the arrangement shown in Fig.5 you might want to investigate some other possibilities. Fig.6 shows how R1 and R2 can be replaced by two light-dependent resistors (LDRs). You can examine the LDR's properties by moving the mouse pointer over the component symbol, as shown in Fig.6. Alternatively, right-clicking the mouse pointer on the LDR symbol will bring up a menu which will allow you to examine the properties of the LDR. If you click on 'Properties' from the drop-down menu you will then be

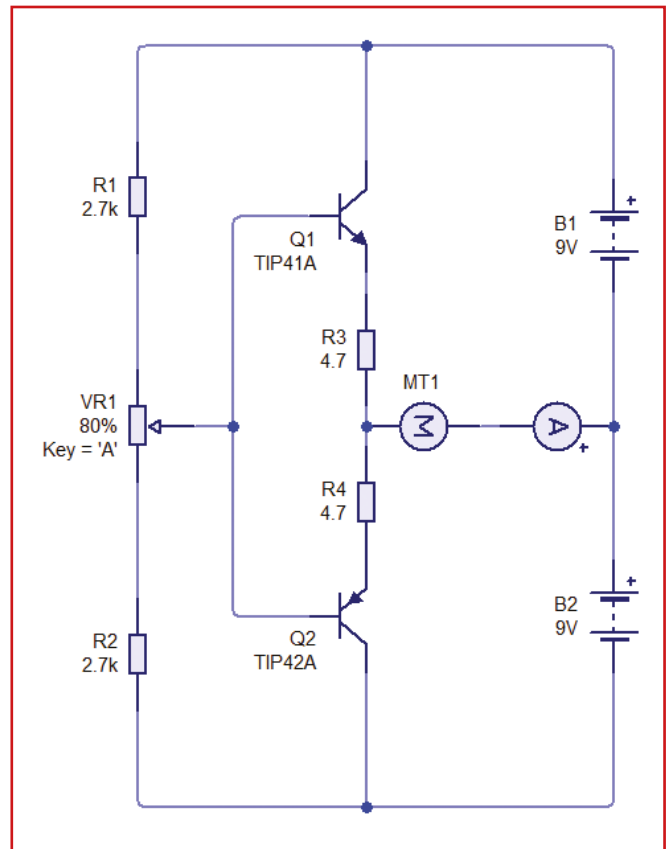

Fig.4. Reversible speed controller

able to assign a key to the LDR. This will provide you with a means of controlling the incident light level from your keyboard when the circuit is being simulated.

Having assigned keys to the two LDRs (we used keys '1' and '2') you will be able to run a simulation and see the light level varying when you press the keys, as shown in

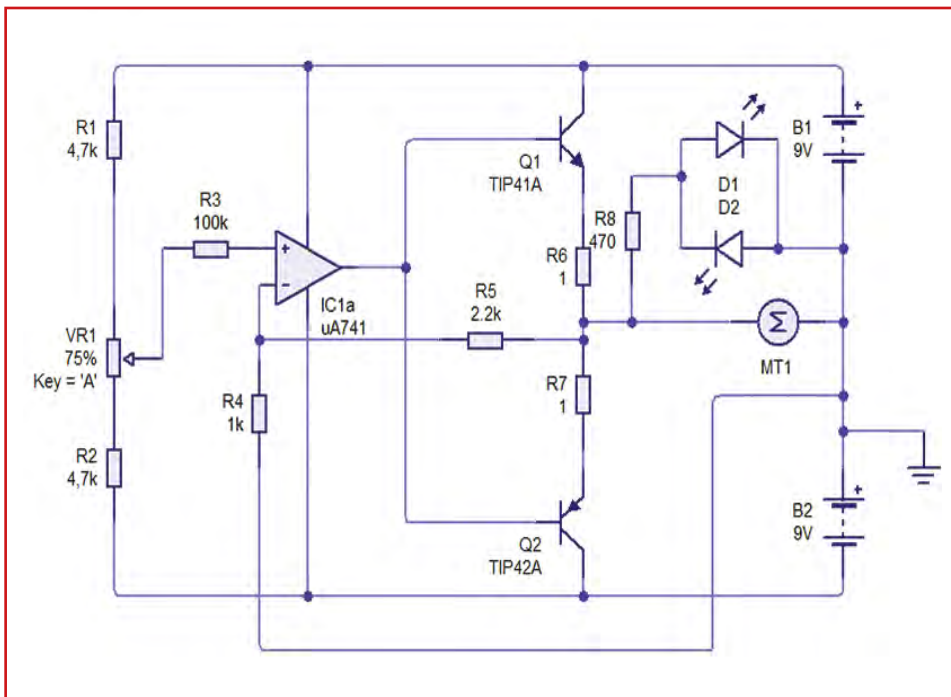

Fig.5. The DC Motor Controller ready for testing using *Circuit Wizard*

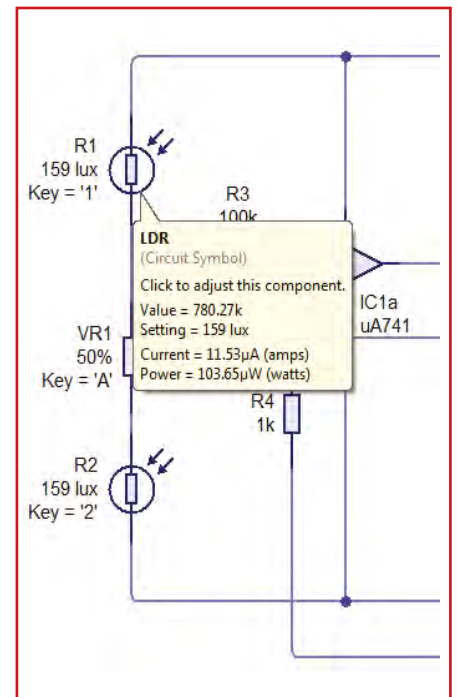

Fig.6. Examining the LDR properties

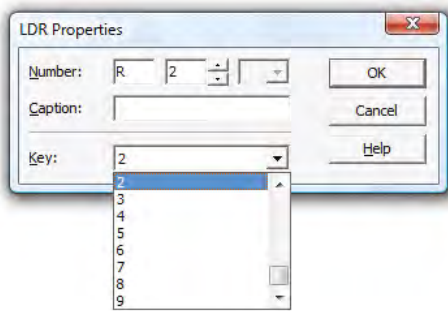

Fig.7. Setting the LDR properties

Fig.7. Finally, Fig.8 shows the motor running when a difference of light level is being experienced by the two LDRs. Note that an unshifted key press will increase the light level of the respective LDR, while a shifted key press will reduce the light level.

When both LDRs are sensing the same amount of light (as shown in Fig.6) the bridge arrangement will be balanced and the motor will remain stationary. If one LDR is sensing more light level than the other, the motor will operate in a direction determined by the relative brightness of the illumination. This exercise should provide you

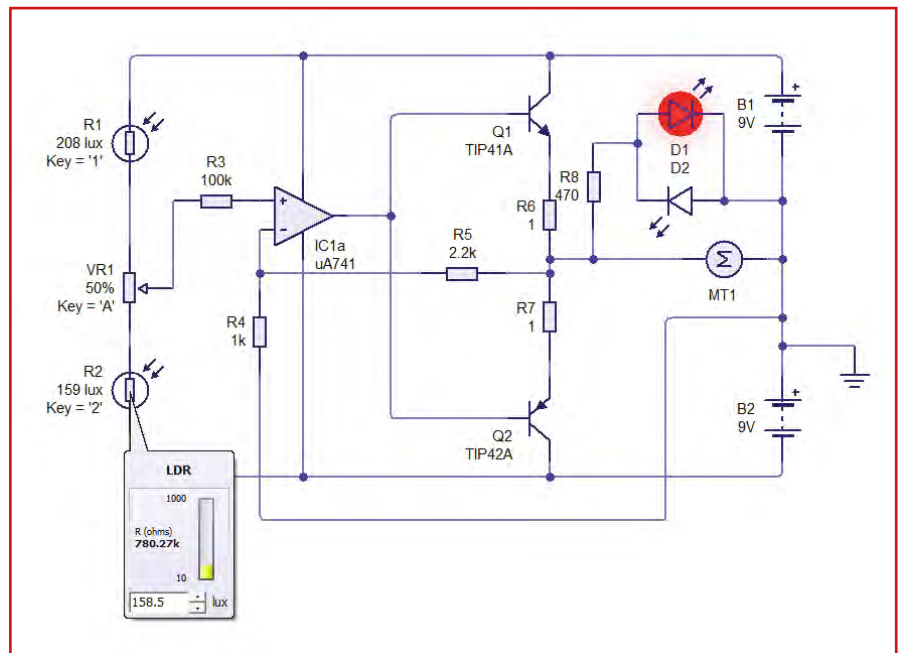

Fig.8. DC Motor Controller responding to differential light levels

with sufficient food for thought in order for you to be able to develop your own light-seeking (or light-avoiding) buggy!

For more info:
www.tooley.co.uk/epe

DC motor controller – using Circuit Wizard

OUR practical DC Motor Controller circuit is shown in Fig.9. The only tweak we have made here is to swap the potentiometer (VR1) used to test the circuit in simulation for a three-pin terminal block ready for connection to an external potentiometer. Unlike some of the other input components, when converting to a PCB, *Circuit Wizard*

does not allow you to select a screw terminal package instead of a PCB mounted variety for a potentiometer. By default, potentiometers are converted as PCB mounting presets. Therefore, this necessitates swapping the component specifically for a terminal block at schematic level before the conversion process.

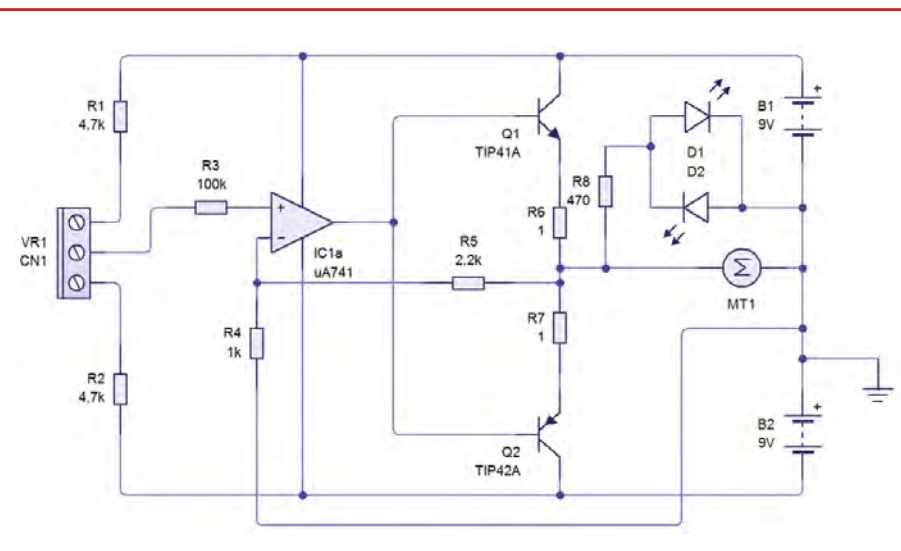

Fig.9. The complete circuit of our DC Motor Controller

Our prototype PCB (Fig.10) was designed to fit on one half of the deck of a pre-manufactured buggy (see later). The board size and mounting points were decided upon and a drilling diagram is available to print out from epemag.com, in the *Jump Start Part 11* folder. Note that by default, *Circuit Wizard* operates in inches (although it is possible to change this to metric within the programme settings) with a default grid spacing of 0.1-inch. Therefore, dimensions were taken in imperial to 0.1-inch for simplicity. Specifying a board size is very straightforward in

Circuit Wizard and is included as an option in the PCB conversion wizard (even if 'Allow me to customise the PCB layout conversion' has not been selected). Four pads were also added to the PCB design at the positions of the mounting holes as a guide for drilling.

Fig.11 shows how the final circuit design can be simulated using *Circuit Wizard*, complete with a virtual representation of the control potentiometer and DC motor. This provides you with a very clear representation of what the real circuit (and its off-board wiring) will look like.

Using the DC Motor Controller

When developing a remote-controlled buggy you have a large range of options depending on whether you are able to use several motors and associated controllers. For test purposes, we built a simple buggy based on a Rapid Electronics kit (Arexx Magician Robot Chassis, product code 13-1192). Using a single controller we were able to make the buggy travel backwards and forwards and make turns. Backward and forward motion (with variable speed controlled by the hand-held potentiometer) was made possible with the two motors connected in series using a single DC motor controller. Turning the buggy one way or the other (at a speed and sense determined by the position of the control potentiometer) was made possible by reversing the polarity of one of the motors using a DPDT switching arrangement like that shown in Fig.3.

A better option is to have individual controllers (each with its own potentiometer) driving each of the motors. The buggy will then need two control potentiometers (one for use in each hand). Turning both to the right will cause the buggy to move forwards (at a speed determined by how far the control is turned). Similarly, turning both to the left will cause the buggy to reverse (at a speed determined by how

You will need...

DC Motor Controller

- 1 PCB, code 893, available from the *EPE PCB Service*, size 81mm x 51mm
- 2 two-way PCB-mounting terminal blocks
- 1 three-way PCB-mounting terminal block
- 2 PP3 battery clips
- 1 8-pin low-profile DIL socket

Semiconductors

- 1 741 operational amplifier (IC1)
- 1 TIP41A *NPN* transistor (Q1)
- 1 TIP42A *PNP* transistor (Q2)
- 1 red LED (D1)
- 1 green LED (D2)

Resistors

- 2 4.7k Ω (R1 and R2)
- 1 100k Ω (R3)
- 1 1k Ω (R4)
- 1 2.2k Ω (R5)
- 2 1 Ω (R6 and R7)
- 1 470 Ω (R8)
- 1 4.7k Ω variable potentiometer (VR1)

far the control is turned). To steer the buggy to the left or right while moving forward it will be necessary to turn one control further than the other. Alternatively, it is possible to rotate the buggy on the spot by turning one control to the right and the other to the left!

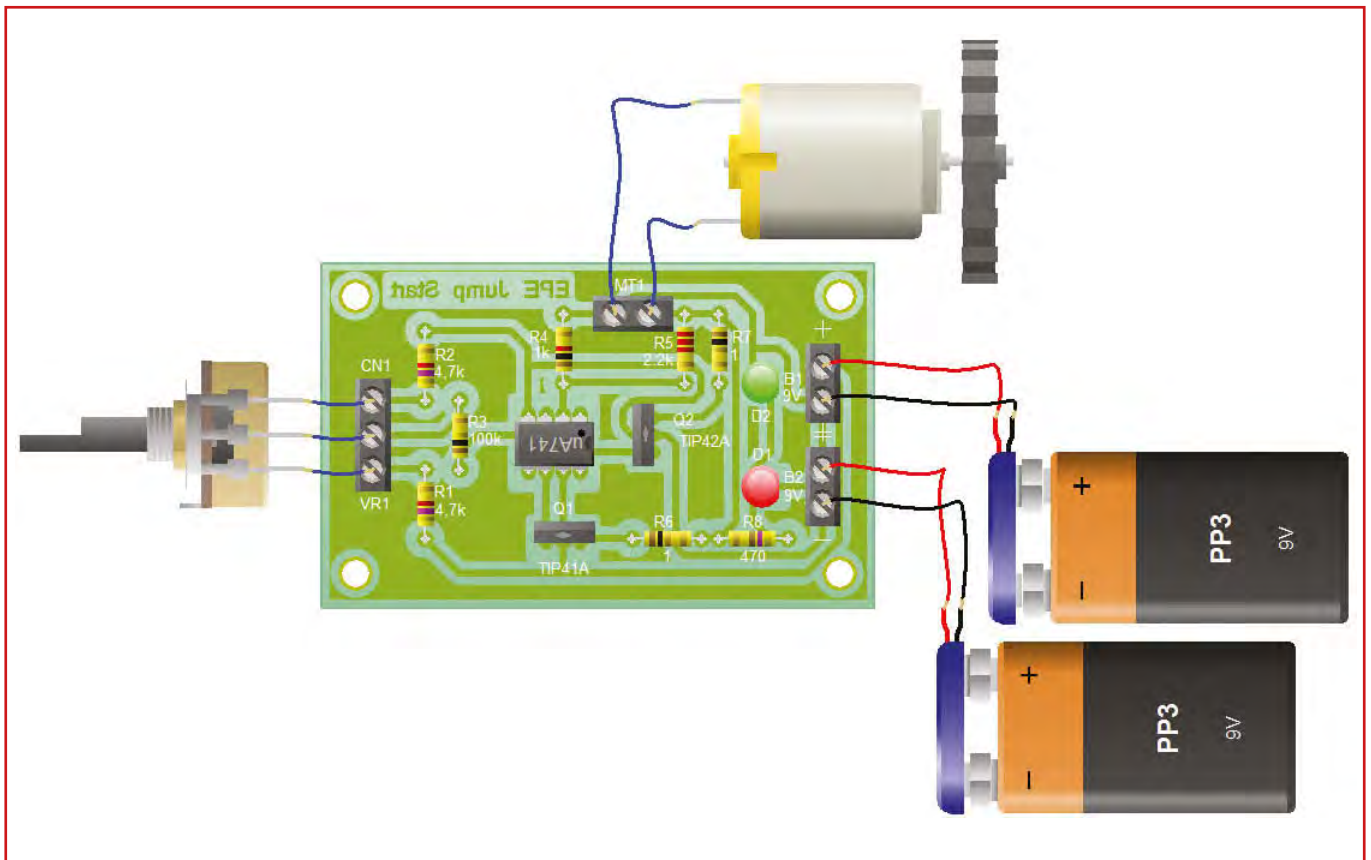

Fig.11. Using *Circuit Wizard* to simulate the DC Motor Controller, complete with control potentiometer

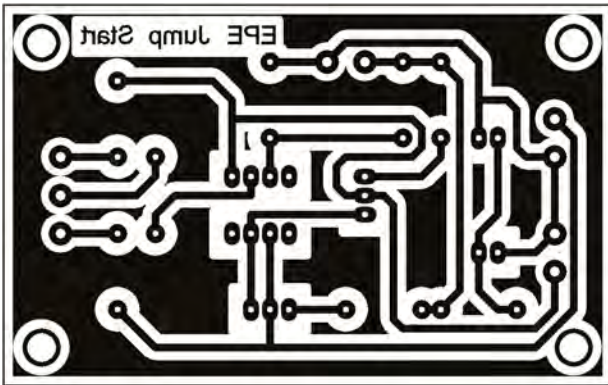

Fig.10(a). PCB track layout

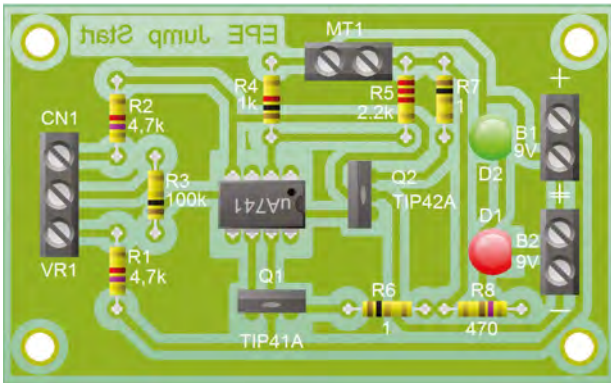

Fig.10(b). PCB component layout

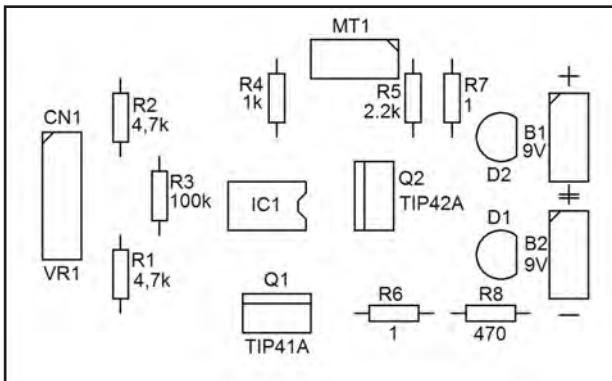

Fig.10(c). PCB component overlay

Next month

In next month's *Jump Start* (and with Easter on the way) we shall be describing an *Egg Timer* that will allow you to cook the perfect egg, soft, hard or something in-between!

Special thanks to Chichester College for the use of their facilities when preparing the featured circuits.

A note regarding Circuit Wizard versions:

Circuit Wizard is available in several variants; Standard, Professional and Education (available to educational institutions only). Please note that the component library, virtual instruments and features available do differ for each variant, as do the licensing limitations. Therefore, you should check which is relevant to you before purchase. During the Jump Start series we aim to use circuits/features of the software that are compatible with the latest versions of all variants of the software. However, we cannot guarantee that all items will be operational with every variant/version.

Photo gallery...

The Gallery is intended to show readers some of the techniques that they can put to use in the practical realisation of a design, such as PCB fabrication and laser cutting. This is very important in an educational context, where students are required to realise their own designs, ending up with a finished project that demonstrates their competence, skills and understanding.

The techniques that we have used are available in nearly every secondary school and college in the country, and we believe that our series will provide teachers with a tremendously useful resource!

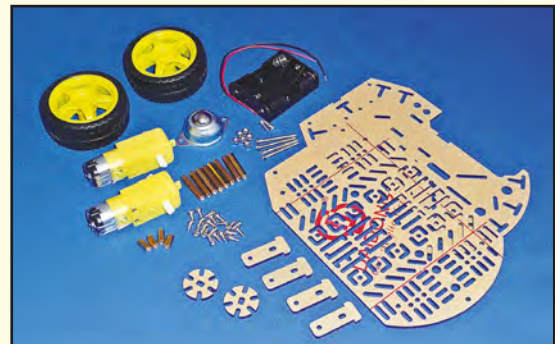

The Arexx Magician Chassis kit

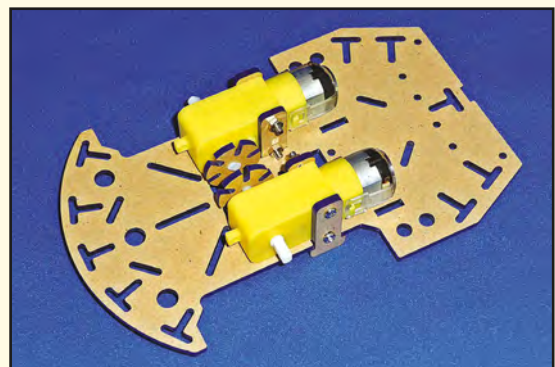

The two DC motors on the underside of the chassis



DC Motor Controller PCB in-place on the buggy chassis

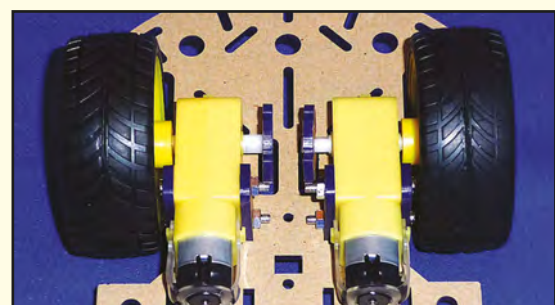

The drive wheels attached to the two DC motors

Raspberry Pi

Further investigation

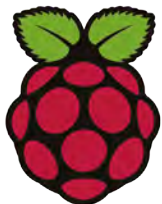

Time for some Pi

Mike Hibbett

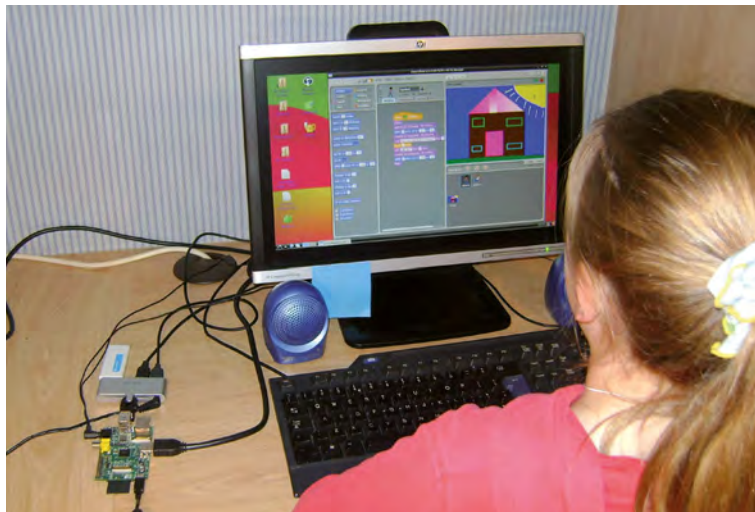

THIS month marks a year since the Raspberry Pi was released to the world. The initial months following the release were a source of frustration to many, as demand significantly outstripped supply, but by the summer things had settled down and it is now possible to walk into your local Maplin store and pick one up.

Community support for both the software environment and the hardware has blossomed and there are now a number of businesses that have emerged providing complete Pi-based systems and hardware add-ons. Bookshops have started stocking Pi-related titles too, with the favorite book having been written by the now well-known Raspberry Foundation member Eben Upton.

The Raspberry Pi Foundation has not been idle. Manufacturing of the Pi has been transferred to the UK (subcontracted to Sony in Wales at the time of writing) and the lower cost (and lower specification) Model A board has been released.

More significantly, the Model B board has been revised and now comes with twice the RAM – 512MB – without an increase in price. We received our ‘Rev B’ board a few weeks ago, so this month we take a look at the differences between the Rev A and Rev B boards, as shown in Fig.1.

Board changes

As mentioned last month, the main differences between the two boards is the addition of two new headers – P5 and P6. P6 is a simple two-pin header for a reset switch, while P5 is an 8-pin header adding four further I/O pins for external hardware. 3V and 5V rails are fitted too, so any external hardware connected to this header can be powered directly from the Pi.

The four I/O signals on P5 are by default general purpose I/O pins, but they can be re-configured to connect to the ARM’s I²C peripheral (using two pins) or to the ARM’s PCM peripheral, which can support an external high quality I²S audio digital-to-analogue converter. The pin designations (as viewed from the underside of the board) can be seen in Fig.2.

Unfortunately, the changes to the Rev B board include moving some of the I/O pin designations on the original P1 header, including pins that we have made use of in our two construction articles. The changes are shown in Fig.3.

The circuit has also been improved to solve a common problem that has plagued people trying to attach Wi-Fi dongles – insufficient power pass-through on the USB interface. This was caused by two resettable fuses in the supply rail to the USB connector. The solution was simple – the fuses were removed. This means that care should be taken with devices attached to the USB port (especially if you design your own hardware). You should be careful to not draw more than 2.5A through the USB port, or you may seriously damage the Pi, as there would be a risk of the tracks melting.

Current consumption

With the small size of the Raspberry Pi and great interest in building portable or remotely located devices, a common question that gets asked is: ‘how long will this run from batteries?’ We measured the quiescent current drain of a Rev B Model B board, and found it to be 370mA at 5V. With the board held in reset by shorting P6, this falls to 120mA. So, if you ran the board from a set of four high capacity D cell batteries rated at 10,000mAh, you are going to get, at best, 27 hours operation.

The board has clearly been designed without battery operation in mind, so if you want to develop a portable project you will have to use some beefy batteries or resort to turning the Pi off when not

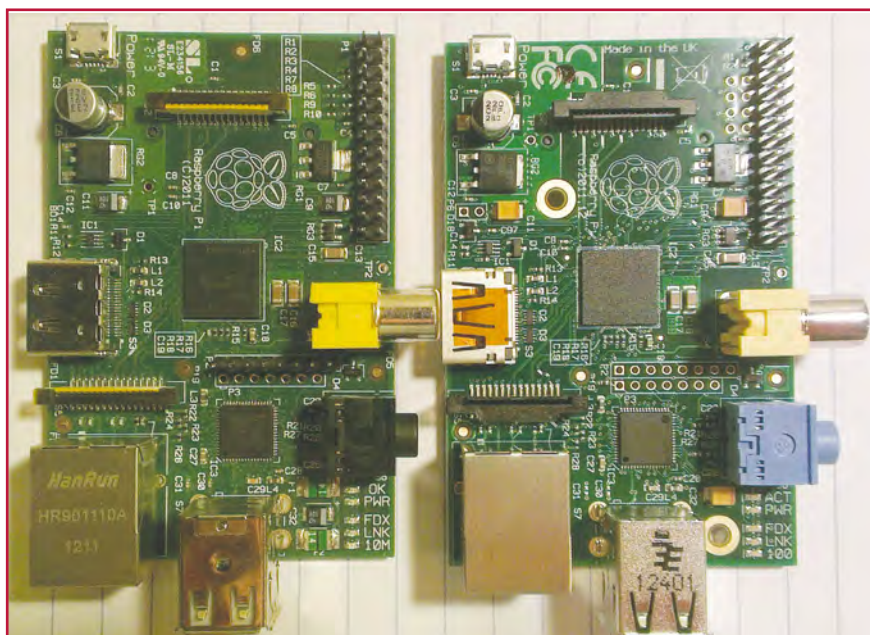

Fig.1. The new Pi – new on the right, old on the left

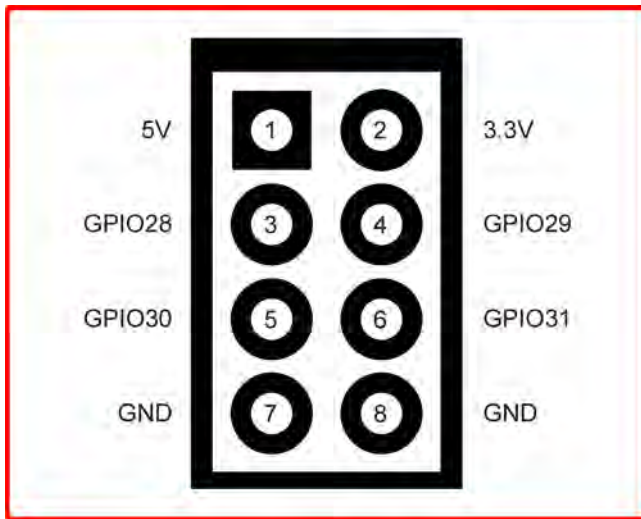

Fig.2. P5 header

in use. One solution is to control the supply to the board from another, low-power microcontroller (such as a PIC!) that powers the Pi board up periodically, or in response to an external interrupt to the microcontroller. Under these conditions, the quiescent current consumption could be as low as a few hundred microamps or lower. If you are interested, we are covering low-power microcontroller operation in the *PIC n' Mix* series at the moment.

Software changes

The Pi's Linux operating system has been updated during the year too, resulting in some significant changes. The latest Foundation recommended release, Raspbian Wheezy, introduces hardware-based floating point support – providing faster floating point operations, particularly useful for graphical applications. Coupled with the extended memory of the Rev B board, this makes the Pi *almost* useable as a desktop system.

Startup time from power-on is not noticeably quicker between the original Rev A board running the original OS and the latest Raspbian OS on a Rev B board; neither is the start-up time for applications. The improvements only show as you start to load the system up with multiple applications. The improvements are slight, however, but welcome.

Autostarting applications

Building the Pi into an embedded project is not much use if you have to connect a keyboard and type the name of the program every time you power the Pi up. Fortunately, the Linux operating system comes with the equivalent of DOS's autoexec.bat file – a bash script that is run on startup into which you can place your own code. This file is called **rc.local**, and lives in the directory/etc.

You can edit this file easily using the leafpad editor. At the end of the file add the commands that you would like to run automatically, for example:

```
printf "automatically starting embedded application"
sudo /home/pi/myapp
```

Save the file, and on startup (with the monitor fitted, of course) you will see the message displayed just before the login prompt. You do not need the keyboard, mouse or monitor connected, unless you want them of course.

There are many different ways in which to start a program on power up, this technique just happens to be one of the simpler ones.

Giving the Pi a static IP address

There are many helpful tutorials for connecting the Pi to a network via a Wi-Fi dongle, and this is likely to be the most common method for getting online. Sometimes, however, it is useful to assign the the Pi a static IP address,



Fig.3. P1 header changes

particularly if you want to connect it directly to your PC – most PCs are not configured to provide DHCP services to other devices, and so we must manually configure the Pi with an IP address.

To network a PC and a Pi together with a standard Ethernet cable you first need to find out what IP address is assigned to your PC's Ethernet interface. The Microsoft Windows operating system does not display an IP address until you connect an Ethernet cable to a powered Pi (or other network device). So to start off, connect them together and apply power.

Open a command shell on the PC (by clicking on **Start** followed by **Run**, then typing cmd) and then giving the command:

```
ipconfig
```

You should see something like this:

```
IPv4 Address..:192.168.1.137
Subnet Mask..: 255.255.255.0
Default Gateway.. : 192.168.1.1
```

This tells us that our PC's Ethernet interface (the wired one, not the wireless interface) has an IP address of 192.168.1.137

We need to give the Pi an IP address that differs in only the last three digits. Pretty much well any number in the range 2 to 254 will do; in our case we have chosen the address 192.168.1.150 for our Pi.

Going back to the Raspberry Pi, start the leafpad editor and open the file

```
/etc/network/interfaces
```

and change the line that reads

```
iface eth0 inet dhcp
```

to

```
iface eth0 inet static
```

Below this line enter the following.

```
address 169.254.154.150
netmask 255.255.0.0
```

save the file and exit. Then reboot the Pi.

You should now be able to telnet to the Pi from your PC.

Next month, we will take a look at the impressive range of programming languages and support tools available for the Pi, and explain their strengths and weaknesses for different tasks.

We can supply back issues of *EPE* by post, most issues from the past five years are available. An *EPE* index for the last five years is also available at www.epemag.com. Where we are unable to provide a back issue a photocopy of any one article (or one part of a series) can be purchased for the same price. Issues from Jan. 99 are available on CD-ROM or DVD-ROM – and back issues from recent years are also available to download from www.epemag.com. Please make sure all components are still available before commencing any project from a back-dated issue.

DID YOU MISS THESE?



BACK ISSUES ONLY £5.00 (each inc. UK p&p.)

Overseas prices £5.80 each surface mail, £6.80 each airmail.

We can also supply issues from years: 2006 (except Jan., Feb., Mar., Apr., May, July), 2007 (except June, July, Aug), 2008 (except Aug, Nov, Dec) 2009 (except Jan, Mar, Apr), 2010 (except May, June, July, August, Oct, Nov, Dec) 2011 (except Jan).

Where we do not have an issue a photocopy of any **one article** or **one part** of a series can be provided at the same price.

JAN '12

PROJECTS • GPS Car Computer – Part 1 • WIB – WebServer In A Box – Part 2 • A Balanced Output Board For The Stereo DAC • Ingenuity Unlimited
FEATURES • Techno Talk • Practically Speaking • Circuit Surgery • Recycle It! • Net Work.

FEB '12

PROJECTS • Air Quality Monitor • GPS Car Computer – Part 2 • WIB – WebServer In A Box – Part 3 plus Add-on • Programming PICs: How It's Done • Ingenuity Unlimited
FEATURES • Recycle It! • Techno Talk • Interface • Circuit Surgery • PIC N' Mix • Net Work.

MAR '12

PROJECTS • High-Quality Digital Audio Signal Generator – Part 1 • Accurate Thermometer/Thermostat • Internet Time Display Module (WIB) • Solar-Powered Intruder Alarm • Ingenuity Unlimited
FEATURES • Techno Talk • Practically Speaking • Max's Cool Beans • PIC N' Mix • Net Work.

APR '12

PROJECTS • EHT Stick • High-Quality Digital Audio Signal Generator – Part 2 • Capacitor Leakage Adaptor For DMMs • WIB FAQs
FEATURES • Techno Talk • Circuit Surgery • Interface • Max's Cool Beans • PIC N' Mix • Net Work.

MAY '12

PROJECTS • Compact High-Performance 12V Stereo Amplifier • High-Quality Digital Audio Signal Generator – Part 3 • Low-Power Car/Bike USB Charger • Solar-Powered Lighting Controller – Part 1
FEATURES • Techno Talk • Jump Start – Moisture Detector • Circuit Surgery • Practically Speaking • PIC N' Mix • Net Work.

JUNE '12

PROJECTS • Digital Insulation Meter • Dual Tracking ± 0V To 19V Power Supply – Part 1 • Low-Power Car/Bike USB Charger • Solar-Powered Lighting Controller – Part 2
FEATURES • Jump Start – Quiz Machine • Techno Talk • Pico 2205 MSO PC oscilloscope • PIC N' Mix • Circuit Surgery • Interface • Net Work.

JULY '12

PROJECTS • Lab-Standard 16-Bit Digital Potentiometer • Intelligent 12V Fan Controller • Dual Tracking ±0V To 19V Power Supply – Part 2
FEATURES • Jump Start – Battery Voltage Checker • Techno Talk • PIC N' Mix • Circuit Surgery • Practically Speaking • Max's Cool Beans • Net Work.

AUG '12

PROJECTS • Ultrasonic Cleaner • Electrolytic Capacitor Reformer and Tester – Part 1 • High-Performance Microphone Preamplifier • High-Power Reversible DC Motor Speed Controller
FEATURES • Jump Start – Solar-Powered Charger • Raspberry Pi Review • Techno Talk • PIC N' Mix • Circuit Surgery • Interface • Net Work.

SEPT '12

PROJECTS • Designing And Installing A Hearing Loop For The Deaf • Hearing Loop Receiver • Ultrasonic Anti-Fouling For Boats – Part 1 • Electrolytic Capacitor Reformer and Tester – Part 2
FEATURES • Jump Start – Versatile Theft Alarm • Raspberry Pi – Real-Time Clock • PIC N' Mix • Circuit Surgery • Practically Speaking • Net Work.

OCT '12

PROJECTS • Two TOSLINK-S/PDIF Audio Converters • Digital Lighting Controller – Part 1 • Ultrasonic Anti-Fouling For Boats – Part 2 • Designing And Installing A Hearing Loop For The Deaf – Part 2 • Ingenuity Unlimited
FEATURES • Jump Start – Spooky Circuits • Techno Talk • Interface • Circuit Surgery • Max's Cool Beans • Net Work.

NOV '12

PROJECTS • Hearing Loop Level Meter – Part 1 • Digital Lighting Controller – Part 2 • RFID Security

System • Easy USB *plus* Telescope Driver Control • Ingenuity Unlimited
FEATURES • Jump Start – Frost Alarm • Techno Talk • Review – Picoscope 3406B • Practically Speaking • Circuit Surgery • Max's Cool Beans • Net Work

DEC '12

PROJECTS • Universal USB Data Logger – Part 1 • Hot-Wire Cutter • Digital Lighting Controller – Part 3 • Hearing Loop Level Meter – Part 2 • Ingenuity Unlimited
FEATURES • Jump Start – Mini Christmas Lights • Techno Talk • PIC N' Mix • Circuit Surgery • Interface • Max's Cool Beans • Net Work

JAN '13

PROJECTS • 3-Input Stereo Audio Switcher • Stereo Compressor • Low Capacitance Adaptor For DMMs • Universal USB Data Logger – Part 2 •
FEATURES • Jump Start – iPod Speaker • Techno Talk • PIC N' Mix • Raspberry Pi – Keypad and LCD Interface • Circuit Surgery • Practically Speaking • Max's Cool Beans • Net Work

FEB '13

PROJECTS • Semtest – Part 1 • Crystal DAC • 10W LED Floodlight • Built-In Speakers • Universal USB Data Logger – Part 3
FEATURES • Jump Start – Logic Probe • Techno Talk • PIC N' Mix • Raspberry Pi – Software Investigation • Circuit Surgery • Interface • Max's Cool Beans • Net Work

ORDER FORM – BACK ISSUES – PHOTOCOPIES – INDEXES

Send back issues dated

Send photocopies of (article title and issue date)

Name

Address

Tel:

I enclose cheque/P.O./bank draft to the value of £

Please charge my Visa/Mastercard/Maestro £

Card No Maestro Issue No

Valid From Card Expiry Date Card Security Code
(The last 3 digits on or just under the signature strip)

SEND TO: **Everyday Practical Electronics, Wimborne Publishing Ltd., 113 Lynwood Drive, Merley, Wimborne, Dorset BH21 1UU.**

Tel: 01202 880299. Fax: 01202 843233.

E-mail: orders@epemag.wimborne.co.uk On-line Shop: www.epemag.com

Payments must be in £ sterling – cheque or bank draft drawn on a UK bank. Normally posted within seven days of receipt of order. Send a copy of this form, or order by letter if you do not wish to cut your issue.

M03/13

Increasing the speed – saving power

WE started looking at low power modes last month, switching between an 8MHz system clock RUN mode and IDLE, where the oscillator is still running but no clocks are fed to the CPU. As the processor is capable of running much faster than 8MHz (using the magic of a phased-locked loop) we will take a look at how we crank up the speed, and what effect this has on the low-power mode. We will also expand our circuit, adding an external low-power high accuracy crystal to provide the basis for a real-time clock, and at the same time providing even further power consumption savings.

The PIC18F processor has a bewildering range of oscillator and CPU

modes – there are eight different oscillator sources available, some of which can be used simultaneously, and you can choose whether these drive the CPU, the peripherals or both. The permutations are enormous, but typically if you are unconcerned about power consumption then the rule is simple – if you need the processor to run at an accurate rate (better than 2% accuracy) then use an external crystal. Otherwise, use the inbuilt oscillator. It will run just as fast, just not as accurately. And as you will find out over the coming articles, this is not often a requirement.

Increasing the speed

Currently, our processor is running at 8MHz from the internal clock oscillator,

giving a 2MHz instruction rate. Changing to the faster internal clock is not a straightforward task; we have to tell the processor to route the 8MHz internal clock through the PLL multiplier, and then route that signal to the CPU. The datasheet shows the clock module diagram in Figure 3-1 on page 36, and a summary is shown in Fig.1. Although this appears complicated, it is only a series of switches and multiplexers – it's just a case of setting the appropriate register control bits to route the signals where you want, similar to wiring up a circuit board. Only we will do it in software rather than solder!

To change from the clock scheme in last month's design we select INTOSC-PLL in the config register CONFIG2L

Fig. 1. Clock modes

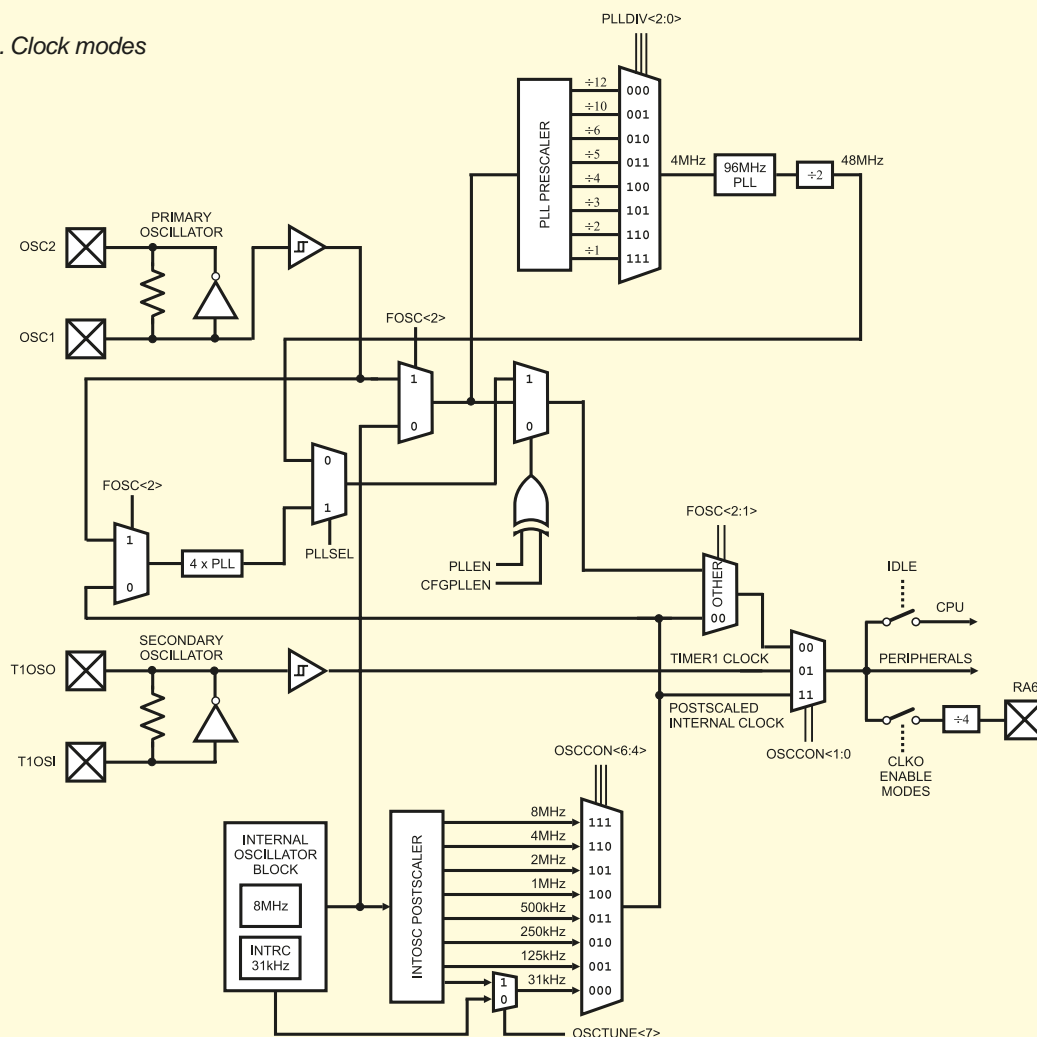

to bring the 8MHz internal oscillator to the input of the PLL prescaler (setting FOSC<2> to 0); CFGPLEND in the config register CONFIG1L to 0 to enable the PLL, and PLLDIV<2:0> in the config register CONFIG1L to 110 to divide the 8MHz signal down to the required 4MHz. Finally, PLLSEL in the config register CONFIG3H must be 0 to use the 96MHz PLL output.

OSCCON no longer controls the speed of the clock, so this register no longer needs to be explicitly set in our software.

Config changes

All of these changes consist of values set in the CONFIG registers; this should come as no surprise, because until the clock is running we cannot execute any instructions – so how could we set them? This chicken-and-egg problem is solved, of course, by specifying the config register values using the CONFIG command in our source file, which the programmer will pick up and write directly into the Flash-memory-based CONFIG registers. To find the appropriate CONFIG commands to use, we had to look back in the 'PIC18 Config Settings' file within MPLAB's help system.

The config setting changes look like this:

```
CONFIG OSC = INTOSCPLL
CONFIG CFGPLEN = ON
CONFIG PLLDIV = 2
CONFIG PLLSEL = PLL96
```

When these changes were made and the code was built and loaded to our circuit, the LED flashed six-times faster – naturally, as we had not changed the timer reload value in our timer configuration code. Good. We are now running at a clock rate of 48MHz rather than 8MHz!

How has this affected our current consumption? With the LED off, the current consumption has risen to 5.5mA – even though the CPU is not running (it's in IDLE mode most of the time), the higher clock speed has increased our 'standby' current by a factor of three. But what would the current consumption have been if we were just running around in an idle loop rather than putting the CPU to sleep? A quick code change to temporarily remove the SLEEP instruction reveals all – 11.7mA. So now, the use of IDLE mode when we run at full speed is saving us 6.1mA.

5.5mA is, however, a fairly poor current to be drawing if you are running off batteries. Even if you were to use expensive 2000mAh AA cells, they are only going to last 363 hours – 15 days. Fortunately, we can do better, much better!

Low-power oscillator

The key to reducing the current consumption is to use a secondary oscillator connected, rather strangely, to the Timer1 module. This oscillator has been designed specially to work with 'tuning fork' style watch crystals, and operates at a very low power.

Crystal types

Normal microprocessor crystals are thin rectangular slabs of quartz with

Fig.2. Microprocessor crystals

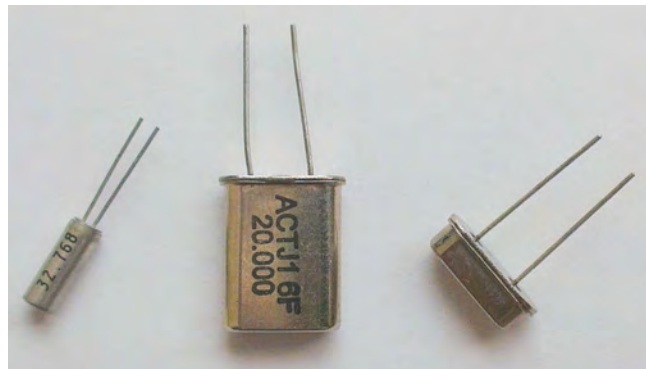

Fig.3. Inside a watch crystal

a conductive coating on either side. An alternating voltage applied to the conductive plates causes the crystal to vibrate, which in turn generates a voltage. As the crystal oscillates at its resonant frequency, the oscillator effectively 'latches on to' this frequency rather than drifting around.

Watch style crystals are cut differently, as miniature tuning forks. These tiny forks resonate at a much lower frequency – the most commonly used frequency being 32.768kHz – but more significantly, they require a much lower drive level to get them to work. (In fact, if you over drive them they will break, which has happened to us on more than one occasion!) Watch crystals are typically supplied in a distinctive tube case, as seen on the left in Fig.2, and in Fig.3, where the outer tube has been removed.

The main drawback of a watch crystal is that it can take a relatively long time for the oscillator to latch on to the resonant frequency and develop a strong enough signal to feed the

microcontroller – it can be in the hundreds of milliseconds. Unless you intend to turn the oscillator off frequently, this is not a serious issue. The other problem to be aware of is that the circuit layout is important – wires between the CPU and the two series capacitors must be kept very short.

So let's go ahead and add a watch crystal oscillator to our circuit, and use that as the source of the timer for our LED flasher instead of the internal RC oscillator. We will still wake up and run at high speed using the 48MHz internal clock, but now we will shut down this clock completely when we go to sleep, and just run the timer from the 32kHz crystal. The updated circuit diagram is shown in Fig.4, and the board layout in Fig.5.

Software changes

The watch crystal oscillator is tied directly to the Timer1 module, so we will change the software from using the main system clock with Timer0 as the source for periodic interrupts to Timer1.

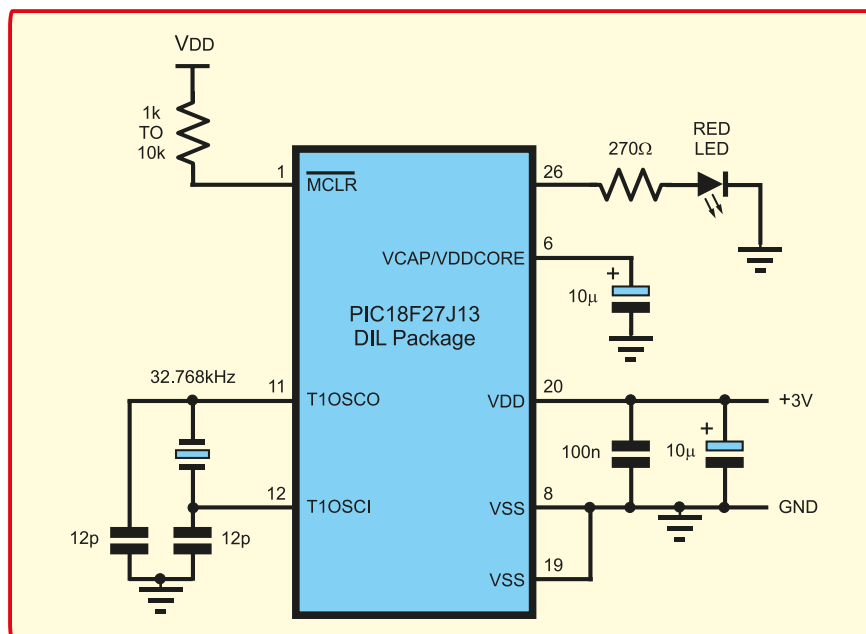

Fig.4. Revised circuit with watch crystal

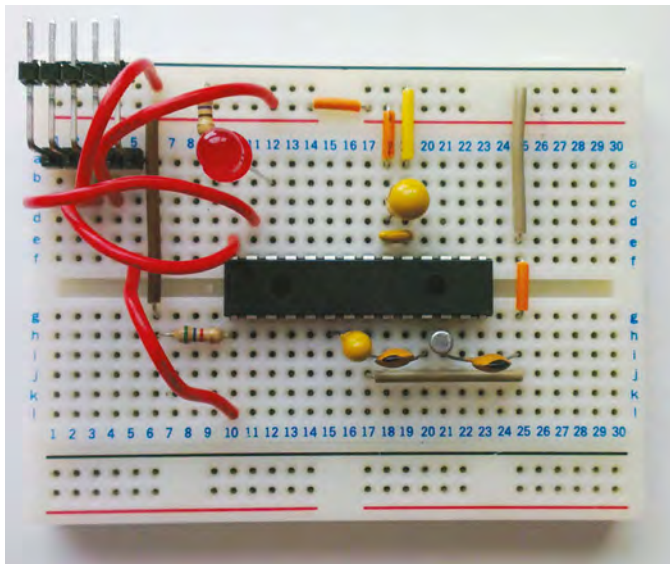

Fig.5. New breadboard layout

The first 'gotcha!' that comes with changing to Timer1 is that its interrupt flag and enable bits are in the peripheral interrupt section, registers PIR1 and PIE1. The technique required to enable interrupts is the same – clear the IF flag, then set the IE flag – but you must also enable peripheral interrupts by setting the PEIE bit in the INTCON register. Next, we need to configure the Timer1 control register T1CON. It's a single 8-bit register and the required settings can be guessed at (we got it right on the second attempt).

The main question was what to set the pre-scaler to. As Timer1 is a 16-bit timer we can leave it as 1:1 – then the timer will overflow once every two seconds. Instead, we will pre-load the timer with a value of 32767, which will cause the timer to overflow and our interrupt to trigger once a second. You can see the final source listing in Fig.6

Running this code on our board gave the same functionality, but as expected, significantly lower current consumption – down from 5.5mA to approximately 50µA. One hundred times lower, meaning our battery life has changed from 15 days to over 4 years – all for the

addition of three passive components costing less than £1!

This significant reduction in 'sleep' power consumption is due to the difference in design of the watch crystal oscillator compared to the standard high speed clock oscillator, as a watch crystal requires significantly less power to make it oscillate. 'Sleep' current, of course, is not the only factor to consider when determining battery life, but as the approach to designing low-power projects is about maximising the time spent in 'sleep' mode, the less power the device consumes in sleep mode the better.

This circuit can now do something the Arduino or Raspberry Pi can only dream of – run off batteries for months at a time. Although it doesn't do anything *useful* yet, we have the basic foundations with which to build on.

```

; Interrupt routine entry address - always 0x0008
org 8
bcf    PIR1, TMR1IF

; only toggle the LED after 10 interrupts
decfsz delay_1s
goto  int_exit

comf   LATB        ; toggle all bits in PORTB

movlw  TOGGLE_LED_TIME
movwf  delay_1s    ; reset the 10s counter

int_exit:
movlw  HIGH TMR1_COUNT_1S
movwf  TMR1H
movlw  LOW TMR1_COUNT_1S
movwf  TMR1L
retfie FAST

main:
movlw  0x00
movwf  TRISB      ; Set PORTB as an output

movlw  TOGGLE_LED_TIME
movwf  delay_1s

bcf    PIR1, TMR1IF
movlw  HIGH TMR1_COUNT_1S
movwf  TMR1H
movlw  LOW TMR1_COUNT_1S
movwf  TMR1L

; Enable the 32KHz oscillator on Timer1
movlw  TMR1_CONF
movwf  T1CON
bsf    PIE1, TMR1IE
bsf    INTCON, PEIE
bsf    INTCON, GIE
bsf    T1CON, TMR1ON

loop:
sleep
goto  loop

```

Fig.6. Source code listing

Next month, we expand the low-power sleep mode to turn the functionality into something really useful – a real-time clock.

The software for this month's article can be downloaded, as usual, from the magazine's website at www.epemag3.com.

Suitable watch crystals suppliers are Farnell part number 1652573, and Maplins part number UJ02C.

Laser *Why tolerate when you can automate?*

 X-10 Home Automation	 C-Bus Shop C-Bus and C-Bus Wireless
 KATS AV transmission and IR control system	www.cbushop.com
 Barix Ethernet based MP3, communications and control systems	Laser Business Systems Ltd Tel: +44 (0) 20 8441 9788 Fax: +44 (0) 20 8449 0430 Email: info@laser.com 16 Garthland Drive, EN5 3BB

www.laser.com

Integrators, Installers, Trade and Retail customers welcome

Coast

Sorting out your bits and pieces? Check out our E-shop...

...We offer components, modules, kits, Led lighting, musical stuff, Industrial, Contract design, device programming, short-range radio, scientific items ...and some really weird things!

And if we don't have what you need... let us know... we just might add it.

COAST ELECTRONICS
8 HOLWORTH CLOSE
BOURNEMOUTH
BH11 8PF
Tel: 01202 244309

www.coastelect.co.uk

Flip-flop architecture

THIS month we have a question about flip-flop triggering posted on EPE Chat Zone by **james**

There are two main types of JK flip-flop:

- 1) Edge Triggered (+ve or -ve edge)
- 2) Pulse Triggered (Master Slave)

With edge-triggered flip-flops, the data is transferred to the Q and Q-bar outputs on a +ve or -ve clock edge.

With pulse-triggered flip-flops, the data is transferred from the J and K inputs into the flip-flop on the +ve clock edge and then appears at the Q and Q-bar outputs on the following -ve clock edge.

I see that edge-triggered flip-flops are readily available in more modern families, eg, 74HC73, 74LS73 and in addition the 4027, whereas the 7473 is pulse triggered. I also see that the 7476 is pulse-triggered but the 74LS76 and 74HC76 are both edge-triggered.

My question – is it true that the pulse-triggered flip-flop (master-slave) was phased out after the standard 74 series, and if so, why?

I read that for pulse-triggered flip-flops the J and K inputs must be held stable during the full time of the +ve clock pulse, otherwise it will affect the outputs as noise on the J and K inputs. If pulse-triggered flip-flops were phased out in newer technologies, could this be the reason?

We will look at the issue of flip-flop triggering by starting with the basic idea of a logic-gate-based memory circuit, and working towards the circuitry used in the pulse-triggered circuit **james** mentions. We will mainly consider set-reset, rather than JK circuits, because they are slightly simpler, but the basic triggering principles are the same.

In this discussion, it is useful to make a clear distinction between latches and flip-flops. A latch is a memory circuit with outputs which may update (change) as a direct result of changes on inputs other than the clock (indeed, it may not even have a clock). The outputs of a flip-flop always update under the control of the clock. The precise manner in which this clock-control happens gives us the difference between pulse and edge-triggered flip-flops, as mentioned by **JAMES**.

Latches or Flip-flops

This distinction between latches and flip-flops is widely accepted as a useful concept, but it is far from universally adhered to, and probably does not date from earliest development of bistable/memory circuits. Under this convention, the well known set-reset circuits shown later in Fig.4 and Fig.5 must be called latches; although they are quite commonly referred to as flip-flops (we will describe their operation in more detail soon). If you are interested in the controversy/confusion surrounding flip-flop terminology, then have a look at the talk page of the flip-flop entry in Wikipedia at: [en.wikipedia.org/wiki/Talk:Flip-flop_\(electronics\)](http://en.wikipedia.org/wiki/Talk:Flip-flop_(electronics)).

Having got past these preliminaries, we can get to the basics of how a latch or flip-flop memory works. Think of two inverters in series (see Fig.1). A 1 in gives a 1 out and a 0 in gives a 0 out. Now consider what happens when we connect the output back to the input, we create a feedback loop circuit with no input (see Fig.2). There is no conflict in the loop since the logic determines that both points A and C from the original circuit are at the same logic level.

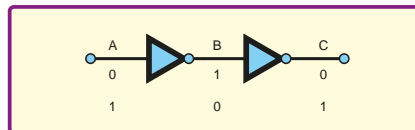

Fig. 1. Two inverters

If point 'A' is somehow made 1, it will stay at that level indefinitely (as long as power is applied). Similarly if we set 'A' to 0, it will stay at 0. This ability to indefinitely hold one of two possible states is the basis of the memory used in latches and flip-flops.

The memory function provided by the circuit in Fig.2 is not particularly useful as there is no input by which it can be given a state to remember. There are a couple of basic approaches to achieving this. First, we can break the loop using a switch and employ another switch to connect the input; this approach is commonly used in CMOS technology, where the switches are implemented using transmission gates. Second, logic gates can be used to modify the logic of the loop in order to enable the state to be set, this approach is used

in TTL technology and is therefore most relevant to **james'** question.

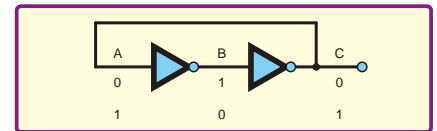

Fig.2. An inverter loop, the basis of latch and flip-flop memory

The circuit in Fig.3 replaces the loop inverters of Fig.3 with two NAND gates. If In1 = In2 = 1 the circuit is equivalent to the two-inverter loop and hence will exhibit the same memory capability. However, if one of the inputs is 0, then the output is forced to either 1 or 0 irrespective of the previously stored value. If In1 = 0 and In2 = 1, an output of 0 is given. This is retained (remembered) even after In1 returns to 1. If In1 = 1 and In2 = 0, an output of 1 is given. This is retained when In2 returns to 1.

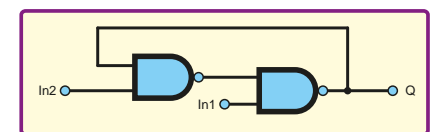

Fig.3. Set-reset latch

Set-reset latch

This type of circuit is called a set-reset latch (SR or RS latch) and its circuit is often drawn in the form shown in Fig.4. A 0 input is used to change the latch's state – the set and reset inputs are 'active low' – hence the bars drawn over them in the diagram.

The output of either gate in Fig.4 may be used; they are complementary and are labelled to indicate this. However, if we set both inputs to zero then both outputs will go to 1, which will break the definition that the outputs are complementary. We are not really using the latch correctly in this case and this condition is commonly referred to as an illegal input. Things get even worse if we return both inputs to 1 simultaneously, because although the outputs will return to a complementary state, their actual values are unpredictable.

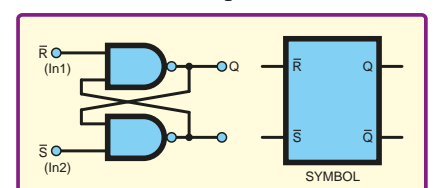

Fig.4. NAND set-reset latch circuit and symbol

If we connect two NOR gates in the same configuration, we get an SR latch with active-high inputs (see Fig.5).

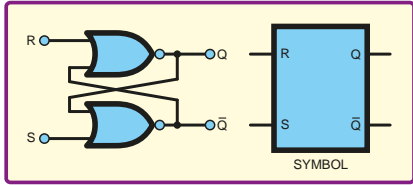

Fig.5. NOR set-reset latch circuit and symbol

Digital circuits often have a clock signal to coordinate activity (more on this later); however, the SR latch does not use a clock to tell it when to store the data. We can modify the circuit in Fig.5 to add a control (or clock) input, C, as shown in Fig.6. When C=1 in Fig.6, the circuit operates as an SR latch (with set and reset active high). When C=0, both of the inputs to the cross-coupled NOR gates are at 0 and therefore inactive. The latch will retain the state it had when C was last at 1. The latch is enabled when C=1 and disabled when C=0

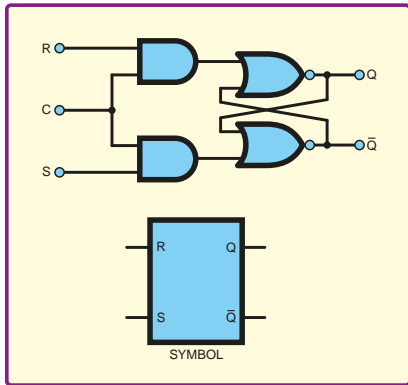

Fig.6. Set-reset latch with control input and symbol

The SR latch (controlled or not) uses separate signals to store 1 or 0. This is often very useful, but it is not convenient if we want to store the logic level of a particular signal (data line). To overcome this we can make a data latch from an RS latch with the addition of extra gates, as shown in Fig.7.

Transparent data latch

With the circuit in Fig.7, when we want to store the state of the D input we make C high. When D is 1 the S input of the SR latch is set to 1 and the R is set to 0. This results in a 1 being stored and output at Q. Similarly, if D is 0 the SR latch is reset. When C is high the Q output follows the value of D, ie, if D changes while C is high, so does Q. When we take C low both inputs of the SR latch are forced low and D has no influence on Q. The latch remembers the last value applied to D while C was at 1.

A memory circuit whose output is either the stored value, or follows the input, is called a transparent latch. The SR latch in Fig.6 could also be described as transparent because, like the circuit in Fig.7, the inputs directly influence the outputs when the clock is 1.

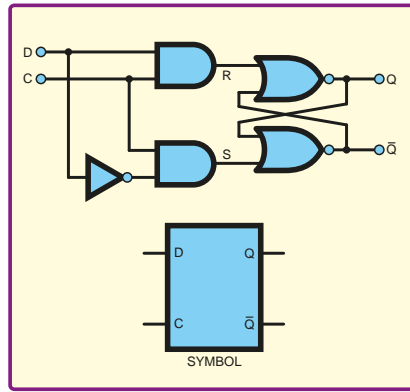

Fig.7. Transparent data latch and symbol

Larger digital circuits typically comprise sets of memory elements interconnected via blocks of combinational logic, as illustrated in Fig.8. The purpose of the clock is to control and coordinate changes in the circuit by determining when new values are loaded into the memories. Thus, the next value stored in a memory will depend on the current values of other memories, the main inputs of the circuit and its own current value (if there is feedback in the circuit).

If we build a circuit using the latches just described, then when the clock changes to 1, all the latches become transparent and may change their outputs. These outputs are connected via logic gates to other latches, which may therefore receive new values at their inputs before they have responded to the original ones. In fact, multiple changes could ripple through the transparent latches, leading to an unpredictable outcome.

Clocked circuits

The latches we have described are therefore very difficult to use when building larger clocked circuits. What we need is a situation where the clock causes all memories to update only based on their currently prevailing inputs and then locks out any further updates until the circuit has settled in response to just this change. To do this, we need to prevent the memories from ever becoming transparent. The clock needs to be the sole means by which the output change can be triggered. We can achieve this by using two latches in series with opposite clock polarities.

Consider the circuit in Fig.9, where the latches are both of the type shown in Fig.6. Then, if C = 1, C of L1 is 1 and C of L2 is 0, so L1

Fig.8. Simplified, generalised sequential logic circuit comprising clocked memories (M) and combination logic (CL). Every memory is controlled by the clock, but for simplicity this is not shown

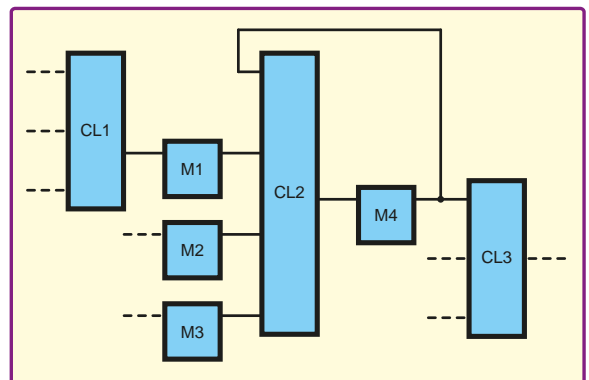

is transparent and L2 is holding data. When C = 0, L1 is holding data and L2 is transparent. Thus, the circuit as a whole is never transparent; one latch is always holding when the other is transparent.

When C in the circuit in Fig.9 is 1, L1 will respond to the current state of the R and S inputs, but this will not affect the outputs because L2 will be holding the current stored value. When C changes from 1 to 0, L1 will hold whatever state it is in at that point and this will pass through to the outputs as L2 becomes transparent. During this time, L1 is holding, so it does not respond to R and S. Thus we see that R and S never directly change the outputs and we can, in accordance with the convention stated earlier, call this circuit a flip-flop (rather than a latch).

The circuit in Fig.9 is referred to as a master-slave flip-flop because the value held and output by L2 (the slave) is controlled by L1 (the master). The circuit is described as pulse triggered because the update process requires a pulse to logic 1 on the clock. On the 0 to 1 change of C the current values of R and S set the state of L1. If we assume R and S do not change when C is high this value will be transferred to the output when C changes from 1 to 0. The fact that the value captured at the start of the clock pulse does not appear until the end of the pulse is referred to as a postponed output. The] symbols next to the flip-flop's outputs on the schematic symbol indicate that it has this behaviour.

For the circuit in Fig.9, when C is 1, L1 responds to every change on R and S. Thus, for example, if R pulses to 1 (reset) then S pulses to 1 (set) and L1 will be set – the reset condition will be forgotten, even though it occurred within the current clock pulse on C. This behaviour is termed ones catching and is potentially problematical when building larger circuits with this flip-flop.

Consider Fig.8 again, assuming the memories are the circuit in Fig.9. The input to M4 comes from a combinational logic circuit (CL2) – assume this input is M4's reset and that the set is not shown. The memories connected to CL2's inputs will all change at more or less the same time when the clock updates all the memories (on its 1 to

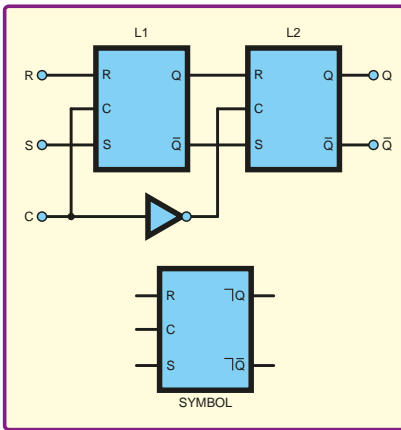

Fig.9. Pulse-triggered master-slave set reset flip-flop and symbol. Note the postponed output symbols on the flip-flop symbol

0 transition). Unfortunately, when multiple inputs to a combination logic circuit change simultaneously the circuit's outputs may produce glitches.

Glitches

Glitches are caused by unequal delay paths from input to output. For example, assume CL2's output is currently 0, with in input of, say, 0011. Then assume the input changes to, say, 0000, so two inputs have changed. Also assume that CL2's truth table gives an output of 0 for both these input combinations (0011 and 0000). The change on one of the inputs may, via a short path through the logic cause the output to change to 1 after a short delay; however, the other input change may take longer to propagate through the circuit resulting in the final output of 0. Thus the output pulses to 1 temporarily before settling to the correct value.

In the scenario just described, the flip-flop in Fig.9 may 'catch' the glitch and reset, despite the fact the true input value is 0 and no reset should have occurred. This leads to the requirement, stated in *james'* question that 'inputs must be held stable during the full time of the +ve clock pulse.' This condition is hard to achieve and is indeed a good reason for pulse-triggered flip-flops becoming obsolete. The term 'glitch' (the situation just described)

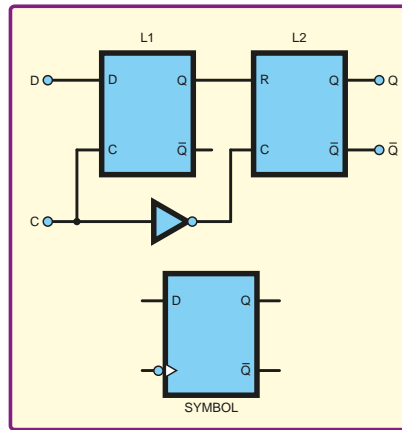

Fig.10. Negative edge-triggered master-slave D-type flip-flop and symbol

is generally more appropriate than 'noise' in this context, but *james'* description is basically correct.

The old 7476's circuit is similar to the one in Fig.9. It has some additional gates to implement the JK behaviour, but Fig.9 is adequate to understand its basic operation and shortcomings. Incidentally the JK flip-flop overcomes the problems with all the SR circuits we have shown in this article – the illegal condition when set and reset are both active and the unpredictable behaviour if they both change from this state together – the JK adds a useful toggle action instead of the illegal state.

Consider the circuit in Fig.10, where the latches are both of the type shown in Fig.7. As with the circuit in Fig.9, if $C = 1$, L1 is transparent and L2 is holding data; and when $C = 0$, L1 is holding data and L2 is transparent. Again, the circuit as a whole is never transparent and similarly the D input never directly causes the outputs to change.

When C in Fig.10 changes from 1 to 0, L1 stores the value currently on D. Q of L1 will be held at this value while $C = 0$. During this period L2 is transparent and therefore the value just stored by L1 will appear at the circuit's Q output. This value will not change if D changes because L1 is holding. When C changes back to 1 the value of Q of L1 will be stored by L2. As the output was already equal to Q of L1, Q will not change. The 1 on C also makes Latch 1 transparent, allowing any change on D through to Q

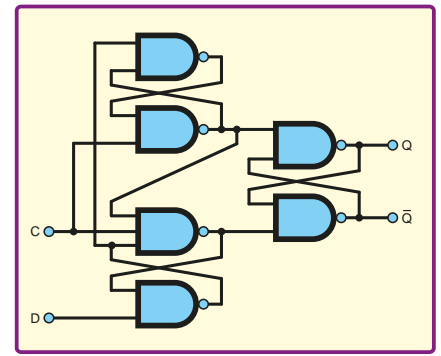

Fig.11. Positive edge-triggered TTL D-type flip-flop which does not have a master-slave structure

of L1. This brings us back to our starting point; a further change from 1 to 0 on C will load a new D value into L1.

Edge triggered

The stored value and hence output of the circuit in Fig.10 is only influenced by D when the clock changes from 1 to 0. For this reason, it is described as being negative-edge triggered. On a flip-flop circuit symbol a small triangle is placed at the clock input to indicate it is edge triggered. Negative (1 to 0) edge-triggered flip-flop symbols have an 'inversion circle' at the clock input, as in Fig.10.

This circuit in Fig.10 has the same master-slave structure as that in Fig.9, but is edge rather than pulse-triggered. This is another potential confusion in flip-flop terminology where 'master-slave' and 'pulse triggered' are sometimes assumed to mean the same thing. The traditional TTL edge-triggered flip-flop has a different structure (see Fig.11), but circuits like that in Fig.10 are widely used in CMOS technology.

Edge-triggered flip-flops, however structured, do not suffer from the 'catching' problem of pulse-triggered circuits. Therefore the constraints on when their inputs have to be stable are much less stringent. In general, their inputs must be stable for a short time before and after the active clock edge (referred to as the setup and hold times respectively). Edge triggered flip-flops are immune to glitches from combinational logic blocks as long as these are finished by the setup time (ie, just before next clock edge).

**TO ADVERTISE IN
EVERYDAY PRACTICAL ELECTRONICS
PLEASE CONTACT**

Stewart Kearn on 01202 880299

**or email
stewart.kearn@wimborne.co.uk**

Get the **MAX** with the **MINI™**

Replace your DIP40 MCU
with a **pin-compatible**
MINI board and get up to
40x better performance!

Keep everything you love about 8-bit MCUs in DIP40 packaging and get up to 40x better performance. Our powerful MINI boards are pin compatible with PIC18F45K2x making them a perfect excuse to smoothly switch to 32-bit. Get used to having plenty of available memory and lots of processing power. Each MINI comes preloaded with a fast USB HID bootloader, so programming is as easy as it gets. Try it out for **\$29 only**.

fast



40x

MINI-M4 for STM32
contains STM32F415RG (ARM® Cortex™-M4)

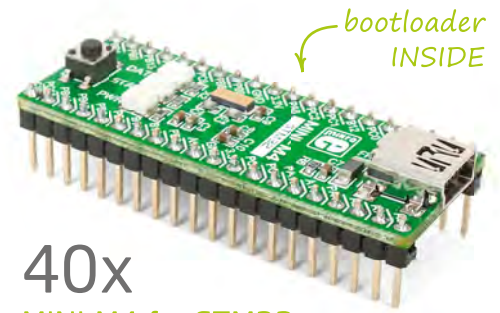

30x

MINI-32
contains PIC32MX534F064H

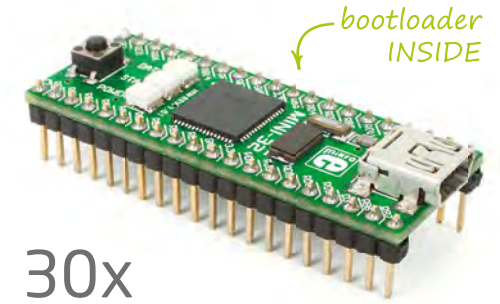

25x

MINI-M4 for Stellaris
contains LX4F230H5QR (ARM® Cortex™-M4)

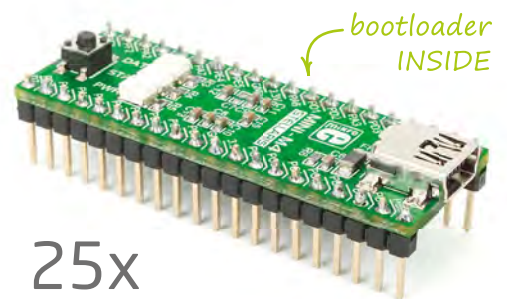

1x

PIC18F45K22

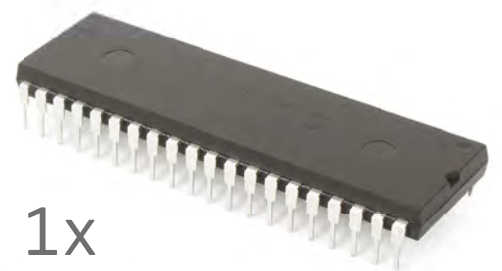

slow

EPE EVERYDAY PRACTICAL ELECTRONICS

EPE Magazine
can now be downloaded at
PocketMags.com
or download the app for
your iPad, iPhone, iPod
Touch or Android phone



The No 1 UK magazine for Electronics Technology & Computer projects is now available to download worldwide

- Each individual issue costs only £1.99
- 6 Month Subscription £9.99
- 12 Month Subscription £19.99
(just £1.67 an issue)



Download Now
and have *EPE* at your
fingertips

Project X!

SUPPOSE it varies from one project to another, but once you have mastered the basics of soldering and have become familiar with the main electronic components and construction methods, the electronic side of project construction is often the relatively easy bit. Obviously, there are exceptions, which are mainly the very large projects and the tiny ones that pack 'a quart into a pint pot'.

The very large projects are relatively difficult simply because there is more opportunity for something to go awry when fitting huge numbers of components on to a circuit board. Tiny projects tend to be like miniature hi-tech versions of getting everything into a suitcase for your return trip from the annual holidays! Neither type really represents a good starting point for complete beginners.

Shaping up

With the more straightforward projects, the circuit board is usually just that, with nothing out of the ordinary to complicate matters. This may also be true of the mechanical side of construction, but the diversity of modern projects is such that there is often some aspect of construction that requires more than drilling a few holes in a ready-made case. Also, many projects have displays, meters, or other panel-mounted components that are awkward to fit. They require relatively large mounting holes and (or) cut-outs that are not circular. In some cases it is necessary to make cut-outs that have quite intricate shapes.

In order to complete the electronics it is likely that only a few tools will be required. Little more than solder, a soldering iron with a stand, some wire clippers and strippers will be needed in most cases. For the mechanical side of construction, an ever-expanding array of tools could gradually be accumulated.

There is probably something to be said for initially avoiding projects that have any really awkward aspects of construction, but before too long it will be necessary to 'spread your wings' and try some projects that are more challenging. I think it is worth repeating the often-given advice that construction of a project should be taken slowly and carefully. This is especially important with any awkward aspects of construction. Rushing at things and trying to get any awkward components dealt with and out of the way as quickly as possible is definitely a mistake. This kind of approach will probably produce scrappy looking results, and the

problem component or components might not fit into place reliably.

Even getting things slightly wrong with some types of component can leave no option other than starting again with a new case, or settling for an obviously botched job. If you need to obtain a new cutting tool in order to make a good job of things, wait until you have obtained the tool before proceeding. Improvising using something that is not really suitable for the job in hand is likely to produce inadequate results, and in some cases could be dangerous.

Many components have simple mounting requirements, such as a single circular hole of around 5mm to 12mm in diameter. The components that tend to be problematic are those that require something more elaborate, which cannot be handled by an ordinary drill and drill bit. Displays, the more elaborate switches, some types of connector, and various other components require rectangular cut-outs, or mounting holes having more complex shapes. With something like a panel meter, the main mounting hole is round, but at around 40mm to 50mm in diameter it is far too large to be drilled in the normal way.

Cheap cuts

There are relatively inexpensive tools that make it easy to produce large circular holes, but producing anything other than round holes with good accuracy requires a fair amount of skill. It may also require a fair amount of patience. If you are new to this type of thing it will probably be necessary to put in some practise with scrap pieces of aluminium or plastic before you go to work on the actual case. With any large but non-circular hole it is usually a matter of marking the outline of the mounting hole and then cutting it as accurately as possible 'by eye' with whatever tool you have selected for the job.

There are several types of tool that can be used to cut holes in cases, but not all of them will necessarily be suitable for a given job. Most of the cases and panels used for electronic projects are made from relatively soft materials such as aluminium or plastic, but cutting large holes can still be very time consuming. With steel panels, even if they are relatively thin, making cut-outs will usually take much longer.

A fretsaw or a coping saw (Fig.1) can be used to make cut-outs of practically any size or shape. These two types of saw are essentially the same, but a fretsaw has a taller frame that enables

it to make cuts in the middle of large panels. However, a coping saw is probably the better choice in the current context because most electronic projects are quite small, and the additional reach of a fretsaw is unlikely to be of any advantage. The taller frame of a fretsaw makes it a bit unwieldy, and obtaining accurate results is easier using a coping saw.

A blade specifically designed for use with steel is required when working on this material. There are blades designed specifically for cutting aluminium and plastic, but practically any coping or fretsaw blade seems to cope quite well with these relatively soft materials. It is important to proceed quite slowly when cutting plastic. Otherwise there is a risk of the blade getting hot, melting the plastic around it, and clogging the blade. In an extreme case the molten plastic will solidify and weld the blade to the case!

Miniature round files offer an alternative to fret and coping saws. For obvious reasons, these are also known as 'needle' files. These files are often sold as sets containing an assortment of shapes and sizes (Fig.2). It is a good idea to have a set of needle files right from the start. In addition to being able to make cut-outs of virtually any size or shape, they are also useful for tidying rough cut-outs and making small adjustments to them. Needle files are relatively slow in use because they remove more material than the fine blade of a fret or coping saw, but they provide an inexpensive way of making practically any required hole, regardless of its size or shape.



Fig. 1. A coping saw is relatively inexpensive, but can be used to make cut-outs of practically any size or shape. This one is fitted with a tension file blade

In the past I have often recommended a type of 'needle' file called an 'Abrafile'. As far as I can ascertain, these are no longer available in their original form, which was a sort of flexible needle file. They still turn up from time to time as tension files, which are very fine round files that are fitted into a coping saw frame. Unlike a normal saw blade, a tension file enabled cuts to be made in any direction without rotating the saw. This type of blade is less prone to snapping than is a normal coping saw blade. The only drawback is that the cut is less fine than the one obtained using a normal blade, giving a slight loss of precision. Tension files are certainly worth having, if you can actually manage to obtain some.

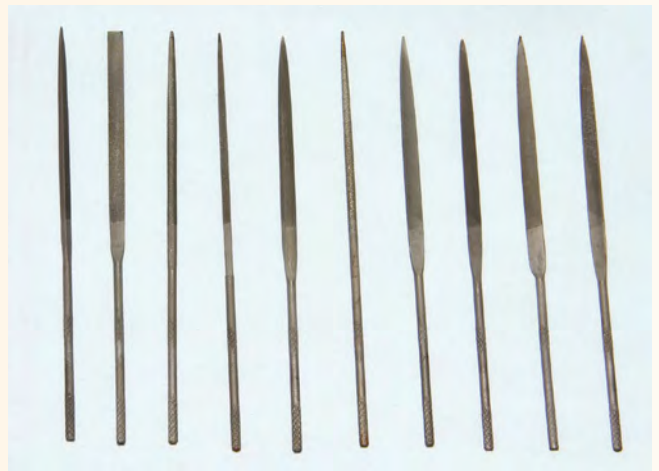

Fig.2. 'Needle' files are often sold in sets containing a variety of shapes. A round type is all that is needed for making cut-outs, but other types are useful for tidying cut-outs

Going straight

A sheet metal nibbler provides a quick way of making fairly large cut-outs that have straight edges. Most of these are expensive power tools that are intended for making large cut-outs in sheet steel. The slightly weirdly named 'hand nibbler' (Fig.3) is a more appropriate choice in the current context. Most of these are suitable for use with up to 18 or 16 gauge steel, and can also be used with aluminium and the softer types of plastic. Some of the harder plastics are prone to cracking or even shattering, and always have to be worked with care. Using a nibbler with any plastic of this type more or less guarantees disastrous results.

As its name suggests, a nibbler cuts out a small piece of material each time it is operated. It removes a small rectangular piece, which is why it is not possible to make curved cuts. However, you can cut just within the perimeter of the required cut-out and then 'fine tune' it using a half-round file. Some nibblers work better than others, but a nibbler produced by one of the large tool manufacturers should give good results. A big advantage of a nibbler is that it cuts relatively quickly, but it follows from this that things can go awry quite suddenly if you get carried away and do not take due care. You definitely need to practice with some scrap sheet material before using one of these in earnest.

Punch-up

Drills suitable for use with plastics and metals are readily available in sizes up to about 10mm or 12mm in diameter, but a different approach is needed for holes having a larger diameter. There are tools specifically designed for making large diameter holes, and at one time the chassis punch was the standard choice for holes up to about 50mm in diameter. A chassis punch (Fig.4), even if old and well used, normally produces extremely 'clean' and professional looking results.

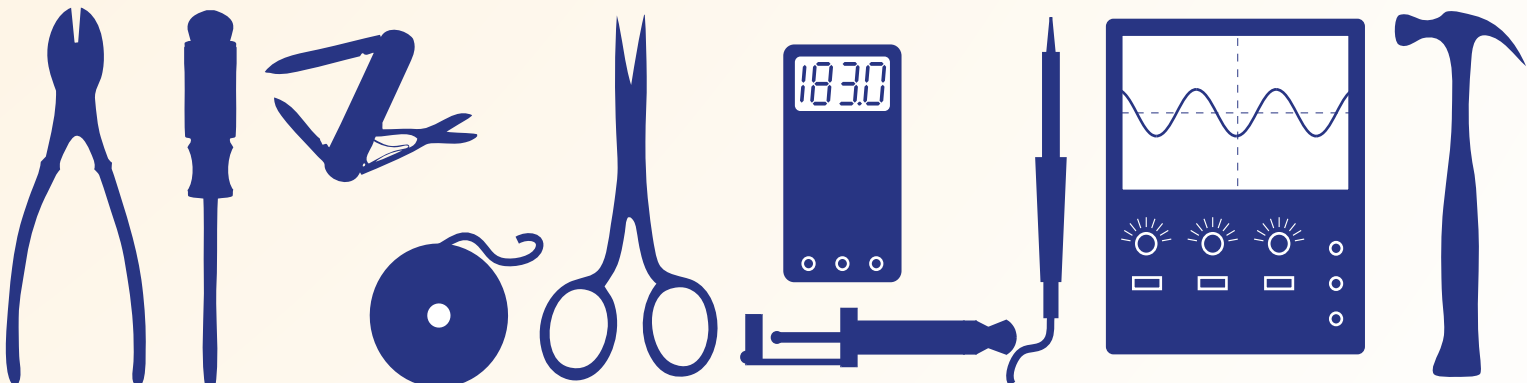



Fig.3. A hand nibbler can quickly cut through most thin sheet materials. A tool of this type can be used to produce large cut-outs very quickly, but it cannot be used to make curved cuts

Before using a chassis punch it is necessary to drill a small guide hole in the panel. A bolt fitted with a circular cutting blade is then fitted into this hole. A nut and a short metal tube or 'die' are then fitted on to the bolt on the opposite side of the panel. An Allen key is used to tighten the nut, and this gradually forces the cutting blade through the panel and into the tube, punching a hole in the panel as it goes. Chassis punches have waned somewhat in popularity, probably due to their relatively high cost. Another drawback is that a separate punch is required for each size of hole. This did not matter too much in the days when two or three punches covered most requirements, but is a bigger stumbling block with the much wider range of components currently in use. However, they still represent the best tool for the job if high quality results are needed.

There are cheaper, and in some cases more versatile alternatives to chassis punches. Hole saws provide an inexpensive alternative, but they

are only available in relatively large sizes. A tool of this type is basically just a saw blade in the form of a ring. It is used with a mandrel that enables it to be mounted in a drill. As with chassis punches, a small central guide hole is required. However, the drill bit is usually incorporated in the mandrel. The guide hole is drilled first, and then the saw blade comes into action, cutting the main hole. Most hole saws have relatively thick blades that

remove quite a lot of material when cutting each hole, and they are designed for use at fairly low speeds. Despite this, holes having diameters of around 25mm to 65mm can be produced quite quickly, and with reasonably 'clean' results. As with chassis punches, a different tool is needed for each size of hole. However, an inexpensive set of hole saws complete with a mandrill is adequate for most electronic project work.

Hole cutters are similar to hole saws, but they have one or two adjustable blades that can accommodate any size of hole within certain limits. They are also known as 'tank cutters', and I presume that their intended purpose is making holes in water tanks. They are relatively slow in use, but still provide a reasonable quick and easy way of cutting large diameter holes. The results obtained are not always very good though, they tend to cut holes with slightly bevelled edges. It is best to cut slightly undersize holes and then file them to the required size, cleaning up the edges as you go.

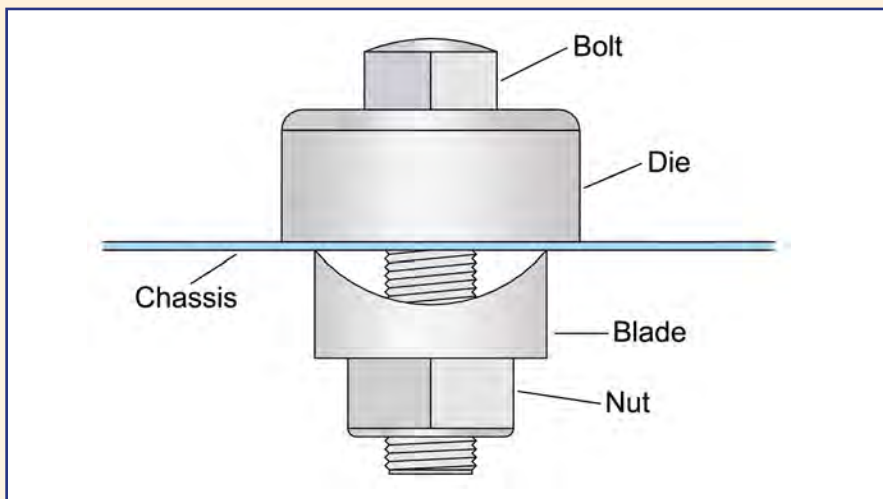

Fig.4. A chassis punch literally punches holes in sheet material using a curved cutting blade. Very high quality results are produced, but this type of tool is expensive

Need a small and cost-effective device? Look no further.



PoScope Mega1+

Smallest USB 2.0 portable 1MS/s oscilloscope
Data acquisition of analog and digital signals
Data recording
Export to CSV, XLS, PDF and HTML
Simple usage of advanced features
Examples for C++, VB, Delphi and LabView
Free software and updates



PoKeys 56

Smallest USB HID or ETHERNET I/O interface
Keyboard and joystick simulator (USB)
55 digital I/O (configurable)
LCD and LED matrixes driver
6 PWM outputs, 26 encoder inputs
Supports up to 10 I2C, 1-Wire sensors,
up to 7 analog sensors
Expandable with PoNet
Free software and web interface (Ethernet)

Visit www.poscope.com

Polabs



Ingenuity Unlimited

Our regular round-up of readers' own circuits

WIN A PICO USB DrDAQ DATA LOGGER PH KIT WORTH £139

- Use DrDAQ as a data logger
- Use DrDAQ as an oscilloscope
- Use DrDAQ as a signal generator
- Built-in sensors for light, sound and temperature
- Measure pH – just plug in any standard pH electrode
- Sockets for external sensors
- Digital outputs to control external devices
- USB connected and powered
- Use up to 20 USB DrDAQs on a single PC

If you have a novel circuit idea which would be of use to other readers, then a Pico Technology USB DrDAQ Data Logger PH Kit could be yours. After every 20 published IU circuits, the best entry will be awarded a USB DrDAQ Data Logger PH Kit worth £139. In addition, a runner up will be awarded with a USB DrDAQ Data Logger worth £99.

We pay between £10 and £50 for all material published, depending on length and technical merit. We're looking for novel applications and circuit designs, not simply mechanical, electrical or software ideas. Ideas must be the reader's own work and **must not have been published or submitted for publication elsewhere.** The circuits shown have NOT been proven by us. **Ingenuity Unlimited** is open to ALL abilities, but items for consideration in this column should be typed or word-processed, with a brief circuit description (between 100 and 500 words maximum) and include a full circuit diagram showing all component values. **Please draw all circuit schematics as clearly as possible.** Send your circuit ideas to: Ingenuity Unlimited, Wimborne Publishing Ltd., 113 Lynwood Drive, Merley, Wimborne, Dorset BH21 1UU. Email: editorial@epemag.wimborne.co.uk. **Your ideas could earn you some cash and a prize!**

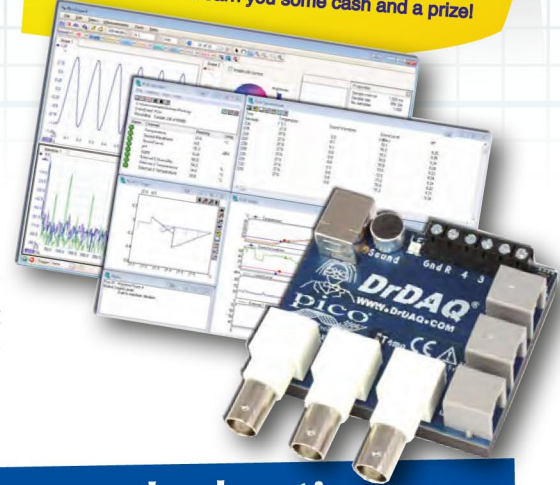

Electric blanket controller – Turn-up the heat!

THIS is an excellent project – BUT, it is only suitable for experienced constructors. This project, and ones like it, use mains power and must not be tackled unless you genuinely feel confident that you have the experience to do so safely. In particular, pay close attention to the author's notes on insulation.

Introduction
I have been following *EPE* since its inception in November 1964, and I still have all the issues up to December 1969. It was a contributing factor in my choice of career, where I spent 40 years in the design and development of electronic systems for missiles and aircraft. I have since retired, but

still like to dabble. I particularly like Microchip PICs and have designed and built numerous projects around them. Last year, my expensive electric blanket with variable heat control failed. I took the controller apart, but it had some components with the identification marks removed, so I couldn't repair it. Being a thrifty sort, I thought I would

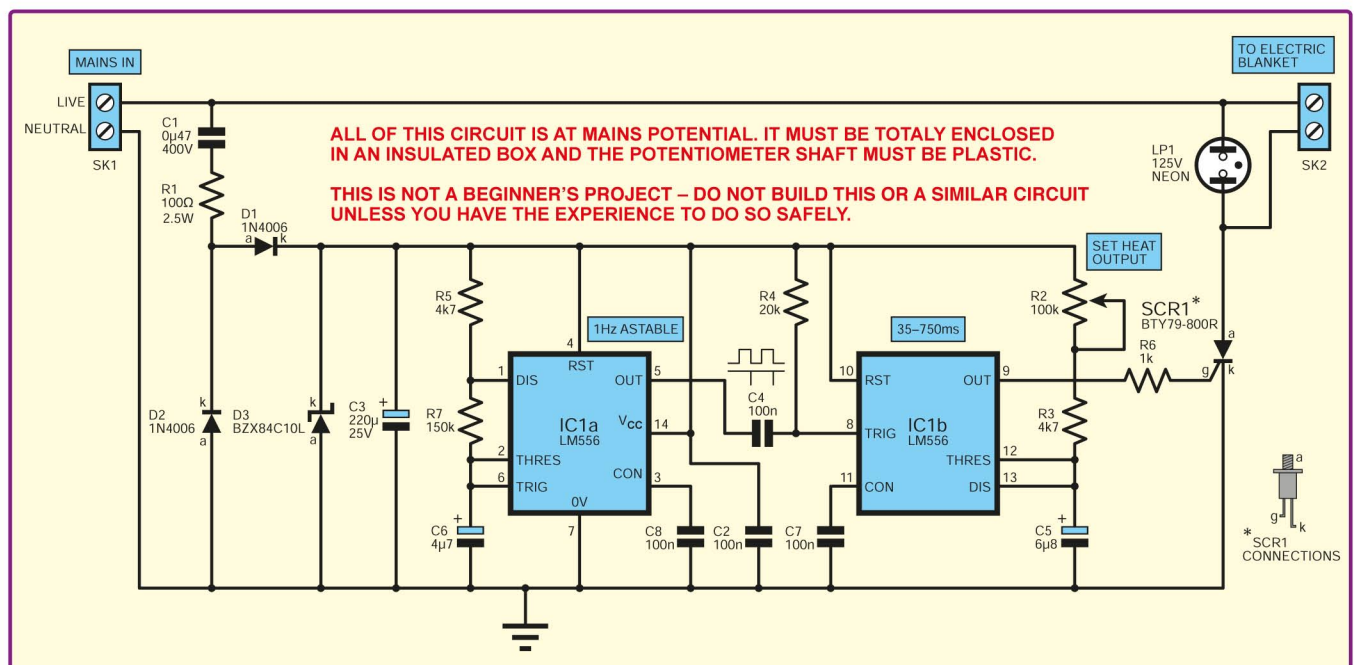

Fig.1. Circuit diagram for the controller

design my own controller; and Fig 1 is the result. The controller has now been in use for more than a year.

The original controller had a diode in series with the output to the blanket, thus providing a half-wave supply to the blanket. My controller uses an SCR to provide the same function. I simply used one which I had available, but the SCR can be any type suitably rated. If your blanket is a 240V full-wave model, then SCR1 could be replaced by a triac and the neon should be rated for 240V.

My blanket is a dual type, which means it has a separate controller for each side. My side failed first, resulting in this controller, but since I built the controller the other side has also failed, and now both sides are fed from my controller. One day, I might get around to building another, so that the two sides of the blanket could be independently controlled again.

Circuit description

A 10V DC supply is derived from the mains 230V AC supply via C1, R1, D1,

D3 and C3. C1 drops the mains supply, R1 limits inrush current, D1 and D2 rectify the supply, D3 stabilises it at around 10V and C3 smooths it.

IC1 is a dual timer, the first half is configured as a 1Hz astable oscillator, whose output is passed via the negative spike generator formed by C4 and R4, to the second timer. This is configured as a variable-length, one-shot. The pulse length is varied via R2 over a range of 35ms to 750ms. The output from the one-shot drives the gate of the SCR via R6. The SCR will then be turned on when the one-shot output is high and will go off after the first zero-crossing of the mains supply when the one shot goes low. The result is that the blanket will receive power for a period variable between 35ms and 750ms, once every second. The neon, LP1, will flash for every burst, giving a visual indication that the blanket is on.

Components

Capacitor C1 is a critical component and **must be an X-rated type with a 400V working voltage.**

All resistors are rated at 0.25W unless otherwise shown. All electrolytic capacitors are rated for at least 25V working. D3 is a 225mW 10V Zener diode. R2 is a potentiometer with a plastic shaft.

Construction

I built the circuit on a piece of stripboard, making sure that high-voltage paths were suitably spaced. Inputs and outputs are via screw terminals and the whole assembly was fitted inside a plastic box. The pot was mounted on the board with only the plastic shaft protruding through the box. The SCR does not need a heat dissipator. No metal parts should pass through the plastic box.

Safety notes

All of the circuit is at mains potential with respect to mains earth. All of the circuit must be enclosed within an insulated box; no part should be exposed or be capable of being touched. R2 must have a plastic shaft.

Ian King, Louth, Lincs

THE ORIGINAL SINCE 1994
PCB-POOL
Beta LAYOUT

create : electronics

FREE Stencil
with every PCB Prototype order

Assembly service
From as little as one component

Embedded RFID
authenticate, track & protect your product
www.magic-pcb.com

Free Phone UK: 0800 389 8560
sales@pcb-pool.com

Beta
LAYOUT
create : electronics

www.pcb-pool.com

eSTORE
Beta LAYOUT

Develop, assemble, solder

€ 36,50*

Arduino Mega (ATMega 1280-16AU) compatible

Reflow Controller
€ 129,00*

UHF RFID Starterkit Basic
€ 279,00*

Large Beta-Reflow-Kit
€ 129,00*

Beta
LAYOUT
create : electronics

www.beta-eSTORE.com

* Incl. VAT and exclusive of shipping costs

EPE IS PLEASED TO BE ABLE TO OFFER YOU THESE

ELECTRONICS CD-ROMS FLOWCODE 5

Complex electronic systems in minutes

New features include:

- C code views and customisation
- Simulation improvements
- Search and replace
- New variable types
- Project auto-documentation
- Project explorer
- Bookmarks
- Improved chip interrupt features
- Compilation errors and warning
- Interrupts overhaul

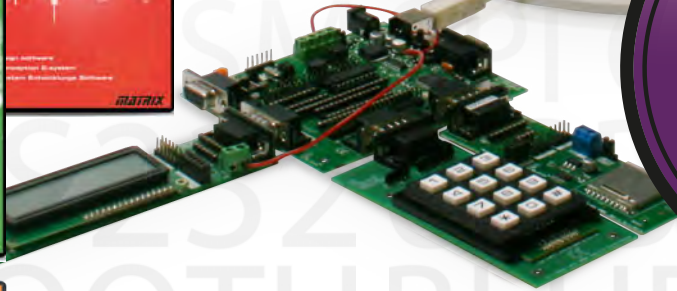
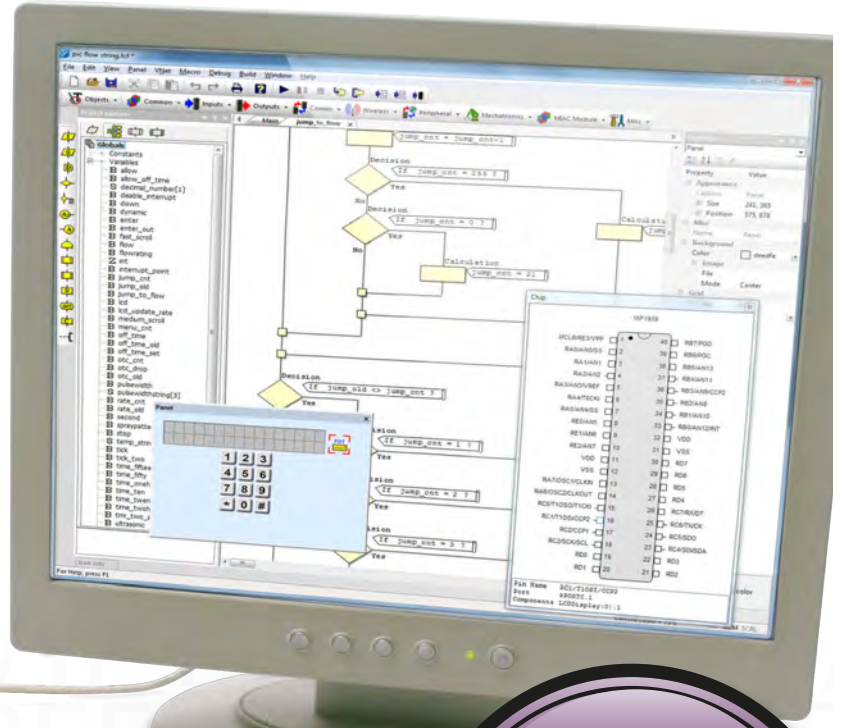

The FlowKit can be connected to hardware systems to provide a real time debug facility where it is possible to step through the Flowcode program on the PC and step through the program in the hardware at the same time. The FlowKit can be connected to your own hardware to provide In-Circuit Debug to your finished designs.

PRICES Prices for each of the CD-ROMs above are:
(Order form on third page)

(UK and EU customers add VAT to 'plus VAT' prices)

Hobbyist/Student
Professional (Schools/HE/FE/Industry)
Flowkit

Flowcode 5

PICMICRO/AVR/DSPIC/PIC24 & ARM Download only

£58.80 inc. VAT
£199.00 plus VAT
£64.90 plus VAT

Please note: Due to popular demand, Flowcode PICmicro, AVR, DSPIC, PIC24 & ARM V5 are now available as a download. Please include your email address and a username (of your choice) on your order. A unique download code will then be emailed to you. If you require the CDROM as a back-up then please add an extra £14 to the above price.

PICmicro TUTORIALS AND PROGRAMMING

HARDWARE

VERSION 3 PICmicro MCU development board

Suitable for use with the three software packages listed below.

This flexible development board allows students to learn both how to program PICmicro microcontrollers as well as program a range of 8, 18, 28 and 40-pin devices from the 12, 16 and 18 series PICmicro ranges. For experienced programmers all programming software is included in the PPP utility that comes with the development board. For those who want to learn, choose one or all of the packages below to use with the Development Board.

- Makes it easier to develop PICmicro projects
- Supports low cost Flash-programmable PICmicro devices
- Fully featured integrated displays – 16 individual LEDs, quad 7-segment display and alphanumeric LCD display
- Supports PICmicro microcontrollers with A/D converters
- Fully protected expansion bus for project work
- USB programmable
- Can be powered by USB (no power supply required)

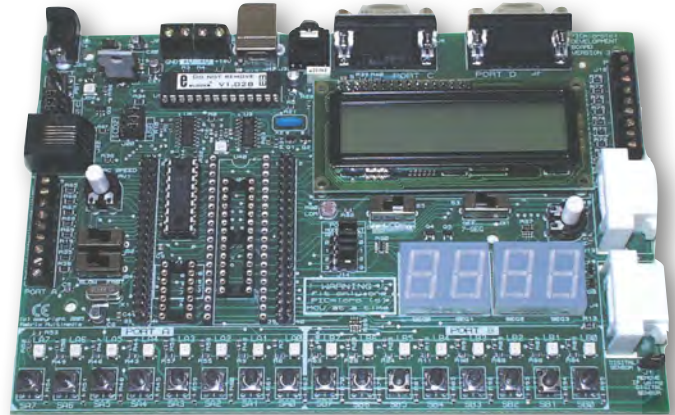

This board is being upgraded, therefore, it is currently unavailable.

£161 including VAT and postage, supplied with USB cable and programming software

SOFTWARE

ASSEMBLY FOR PICmicro V4

(Formerly PICtutor)

Assembly for PICmicro microcontrollers V3.0 (previously known as PICtutor) by John Becker contains a complete course in programming the PIC16F84 PICmicro microcontroller from Arizona Microchip. It starts with fundamental concepts and extends up to complex programs including watchdog timers, interrupts and sleep modes.

The CD makes use of the latest simulation techniques which provide a superb tool for learning: the Virtual PICmicro microcontroller, this is a simulation tool that allows users to write and execute MPASM assembler code for the PIC16F84 microcontroller on-screen. Using this you can actually see what happens inside the PICmicro MCU as each instruction is executed, which enhances understanding.

- Comprehensive instruction through 45 tutorial sections
- Includes Vlab, a Virtual PICmicro microcontroller: a fully functioning simulator
- Tests, exercises and projects covering a wide range of PICmicro MCU applications
- Includes MPLAB assembler
- Visual representation of a PICmicro showing architecture and functions
- Expert system for code entry helps first time users
- Shows data flow and fetch execute cycle and has challenges (washing machine, lift, crossroads etc.)
- Imports MPASM files.

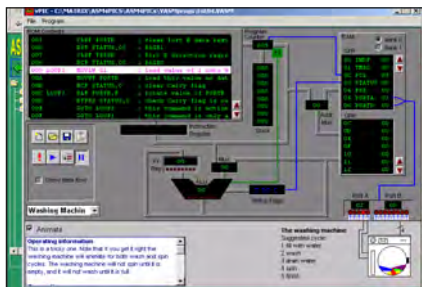

'C' FOR 16 Series PICmicro Version 4

The C for PICmicro microcontrollers CD-ROM is designed for students and professionals who need to learn how to program embedded microcontrollers in C. The CD-ROM contains a course as well as all the software tools needed to create Hex code for a wide range of PICmicro devices – including a full C compiler for a wide range of PICmicro devices.

Although the course focuses on the use of the PICmicro microcontrollers, this CD-ROM will provide a good grounding in C programming for any microcontroller.

- Complete course in C as well as C programming for PICmicro microcontrollers
- Highly interactive course
- Virtual C PICmicro improves understanding
- Includes a C compiler for a wide range of PICmicro devices
- Includes full Integrated Development Environment
- Includes MPLAB software
- Compatible with most PICmicro programmers
- Includes a compiler for all the PICmicro devices.

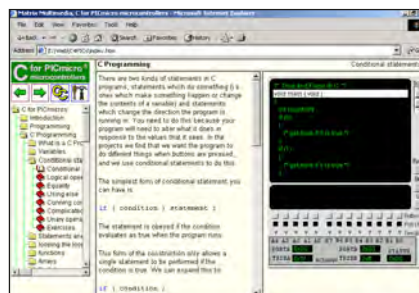

Minimum system requirements for these items: Pentium PC running, 2000, ME, XP; CD-ROM drive; 64MB RAM; 10MB hard disk space. Flowcode will run on XP or later operating systems

FLOWCODE FOR PICmicro V5 (see opposite page)

Flowcode is a very high level language programming system based on flowcharts. Flowcode allows you to design and simulate complex systems in a matter of minutes. A powerful language that uses macros to facilitate the control of devices like 7-segment displays, motor controllers and LCDs. The use of macros allows you to control these devices without getting bogged down in understanding the programming. When used in conjunction with the Version 3 development board this provides a seamless solution that allows you to program chips in minutes.

- Requires no programming experience
- Allows complex PICmicro applications to be designed quickly
- Uses international standard flow chart symbols
- Full on-screen simulation allows debugging and speeds up the development process.
- Facilitates learning via a full suite of demonstration tutorials
- Produces ASM code for a range of 18, 28 and 40-pin devices
- 16-bit arithmetic strings and string manipulation
- Pulse width modulation
- I2C.

Features include panel creator, in circuit debug, virtual networks, C code customisation, floating point and new components. The Hobbyist/Student version is limited to 4K of code (8K on 18F devices)

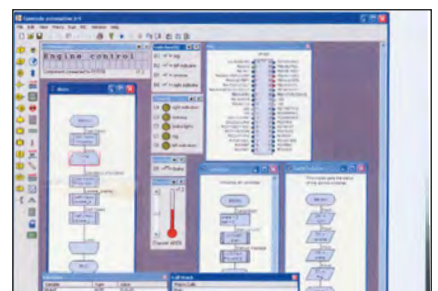

PRICES

Prices for each of the CD-ROMs above are: (Order form on next page)

(UK and EU customers add VAT to 'plus VAT' prices)

Hobbyist/Student	£58.80	inc VAT
Professional (Schools/HE/FE/Industry)	£150	plus VAT
Professional 10 user (Network Licence)	£499	plus VAT
Site Licence	£999	plus VAT
Flowcode Professional (Schools/HE/FE/Industry)	£199	plus VAT
Flowcode 10 user (Network Licence)	£599	plus VAT
Flowcode Site Licence	£999	plus VAT

CIRCUIT WIZARD

Circuit Wizard is a revolutionary new software system that combines circuit design, PCB design, simulation and CAD/CAM manufacture in one complete package.

Two versions are available, Standard or Professional.

By integrating the entire design process, Circuit Wizard provides you with all the tools necessary to produce an electronics project from start to finish – even including on-screen testing of the PCB prior to construction!

- * Circuit diagram design with component library (500 components Standard, 1500 components Professional)
- * Virtual instruments (4 Standard, 7 Professional)
- * On-screen animation
- * Interactive circuit diagram simulation
- * True analogue/digital simulation
- * Simulation of component destruction
- * PCB Layout
- * Interactive PCB layout simulation
- * Automatic PCB routing
- * Gerber export
- * Multi-level zoom (25% to 1000%)
- * Multiple undo and redo
- * Copy and paste to other software
- * Multiple document support

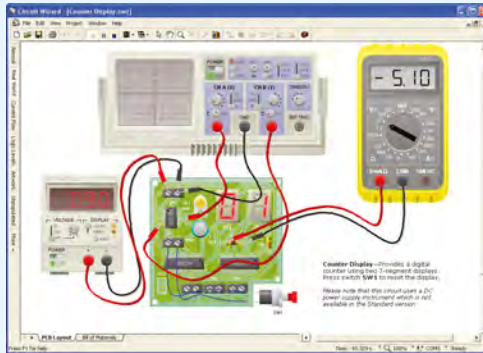

This software can be used with the **Jump Start and Teach-In 2011 series (and the Teach-In 4 book).**

Standard **£61.25** inc. VAT
Professional **£91.90** inc. VAT

Minimum system requirements for these CD-ROMs: Pentium PC, CD-ROM drive, 32MB RAM, 10MB hard disk space. Windows 2000/ME/XP, mouse, sound card, web browser.

EPE PIC RESOURCES V2

Version 2 includes the EPE PIC Tutorial V2 series of Supplements (EPE April, May, June 2003)

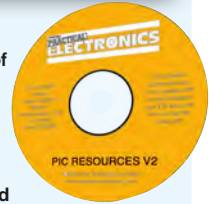

The CD-ROM contains the following Tutorial-related software and texts:

- EPE PIC Tutorial V2 complete series of articles plus demonstration software, John Becker, April, May, June '03
- PIC Toolkit Mk3 (TK3 hardware construction details), John Becker, Oct '01
- PIC Toolkit TK3 for Windows (software details), John Becker, Nov '01

Plus 18 useful texts to help YOU get the most out of your PIC programming.

Price **£14.75** inc. VAT

ELECTRONIC COMPONENTS PHOTOS

A high quality selection of over 200 jpg images of electronic components. This selection of high resolution photos can be used to enhance projects and presentations or to help with training and educational material. They are royalty free for use in commercial or personal printed projects, and can also be used royalty free in books, catalogues, magazine articles as well as worldwide web pages (subject to restrictions – see licence for full details).



Now contains Irfan View image software for Windows, with quick-start notes included.

Price **£19.95** inc. VAT

Please send me: CD-ROM ORDER FORM

- Assembly for PICmicro V4
- 'C' for 16 Series PICmicro V4
- Flowcode for PICmicro V5 (DOWNLOAD + CDROM)
- Flowcode for PICmicro V5 (DOWNLOAD ONLY)
- Flowcode for AVR V5 (DOWNLOAD + CDROM)
- Flowcode for AVR V5 (DOWNLOAD ONLY)
- Flowcode for ARM V5 (DOWNLOAD + CDROM)
- Flowcode for ARM V5 (DOWNLOAD ONLY)
- Flowcode for dsPIC V5 (DOWNLOAD + CDROM)
- Flowcode for dsPIC V5 (DOWNLOAD ONLY)
- Flowcode for PIC24 V5 (DOWNLOAD + CDROM)
- Flowcode for PIC24 V5 (DOWNLOAD ONLY)
- Flowkit



- Version required:
- Hobbyist/Student
 - Professional
 - Professional 10 user
 - Site licence

Email:

Username:

Note: The software on each version is the same, only the licence for use varies.

- PICmicro Development Board V4 (hardware) – currently unavailable.

- Circuit Wizard – Standard
- Circuit Wizard – Professional
- EPE PIC Resources V2
- Electronic Components Photos

Full name:

Address:

..... Post code: Tel. No:

Signature:

- I enclose cheque/PO in £ sterling payable to WIMBORNE PUBLISHING LTD for £

- Please charge my Visa/Mastercard/Maestro: £

Valid From: Card expiry date:

Card No: Maestro Issue No.

Card Security Code (The last 3 digits on or just under the signature strip)

ORDERING ALL PRICES INCLUDE UK POSTAGE

Student/Single User/Standard/Hobbyist Version price includes postage to most countries in the world
EU residents outside the UK add £5 for airmail postage per order

Professional, Multiple User and Site License Versions – overseas readers add £5 to the basic price of each order for airmail postage (do not add VAT unless you live in an EU (European Union) country, then add VAT at 20% or provide your official VAT registration number).

Send your order to:
Direct Book Service
Wimborne Publishing Ltd
113 Lynwood Drive, Merley, Wimborne,
Dorset BH21 1UU

To order by phone ring
01202 880299. Fax: 01202 843233

Goods are normally sent within seven days

E-mail: orders@wimborne.co.uk

Online shop:

www.epemag.com

NET WORK

by Alan Winstanley

Pocket the best!



REGULAR readers will know that some major changes to our online presence were undertaken in December of last year. A number of key factors gave rise to the decision to retire the US-based website, which has operated for about a decade, providing a PDF version of our magazine to subscribers. In addition to copyright concerns, the server was hacked a number of times during the second half of last year, perhaps through a server backdoor.

The team in the USA behind *EPE Online*, Alvin Brown and his colleague Clive ('call me Max') Maxfield, were introduced to *EPE Magazine* in the 1990s when we stumbled upon each other while I was surfing the sci.electronics Usenet newsgroups, on a DOS-based newsreader in my case, in the days before the world-wide web. (The Usenet database was ultimately absorbed into Google Groups.) We met up in England and jointly went on to produce the PhizzyB computer simulator or Beboputer, based on Max's brilliantly-written book 'Bebop Bytes Back' and it featured on *EPE's* first-ever cover CDROM. We have worked closely together as a team and remained good friends ever since.

EPE Online was built from the ground up without any precedent to refer to, at a time when not even a suitable online payment platform was available in the UK, so *EPE Online* was pioneering work in a number of ways. Many readers have sung Alvin's praise for customer service, and it is thanks to Alvin's endeavours at the helm, with web guru Dean Hudson pulling the levers on the servers, that *EPE Online* has been delivered to its readers around the world all this time. Everyone at *EPE* wishes to thank Alvin, Dean and Max for their tireless work in providing what we proudly believe was the world's first magazine that you could also download from the web (from November 1998).

At the same time, we have introduced *EPE* to a new digital newsstand platform that enables us to share our enthusiastic hobby with new readers on the web. With the drive towards real-time online access and the trend towards mobile and tablet computing as well, our new online issue is being handled through the *PocketMags* platform, an internationally-connected service that offers many magazine titles conveniently under one location. By logging into your *PocketMags* account, magazine issues under your subscription can be viewed on-screen, e-book style, but you can also search and purchase many other magazine titles as well. Readers for PC, Mac, Kindle Fire, Android, Apple iPad and iPhone, Blackberry Playbook and Windows 8 are all available free from *PocketMags*.

A new Beta *PocketMags* reader allows the proprietary file to be downloaded for accessing when not online. You can bookmark pages, select and print them, delete files off your PC to save space and simply download them again from your *PocketMags* account when needed. It is pointed out that this beta program is still under development, and that *PocketMags* welcomes user feedback. More details are available at: www.epemag.com/buy-epe-online.html

Many new subscribers have not come across our title before and the addition to our readership numbers has been very encouraging. Welcome aboard! Many existing readers have also told us directly that they are enjoying accessing *EPE* this way for the first time, and they can check out other titles on the digital newsstand too. However, we know that not everyone likes the idea of change when it happens. Our changes were implemented in a tight timeframe and there is no doubting that a number of *EPE Online* users were vociferous in expressing their views. In today's economy, though, it's just a fact of life that the best businesses have to make tough decisions fast, but we will always strive to 'do the right thing' by readers, dealing individually and offering options for existing *EPE Online* subscribers as far as possible. Although we cannot pretend that we will resurrect the 1990s way of doing things, *EPE Online* subscribers are welcome to contact stewart.kearn@wimborne.co.uk for personal attention to their queries.

Far sited

In tandem with this transition, *EPE* launched the framework of its new website. It is accessible at www.epemag.com or (same thing) www.epe-magazine.co.uk. The static website is smaller, but simple and clean to use and over time its contents will be expanded to support legacy issues of *EPE* magazine. It is being updated monthly by the writer, just as it has been every month without interruption since 1996, the year that *Net Work* first appeared.

A new Library is also being built to host our source codes and PCB files from the past 12 years or so. These files are already available online, but until work on the front-end of the website is completed, readers wishing to locate older files can send a blank email to downloads@epemag.com. Our autoresponder will send details of how to download them directly from the web. Of course, if there are any questions then we are just an email away: contact details are on the new website. Don't forget that the author's own site at www.epemag.net hosts files



Work on our new website is well under way, log on at www.epemag.com

from the earliest days of *EPE's* PIC projects. While we are fully committed to the new platform, we know how readers value their prized collection of back issues, so we will also be making available *EPE* Back Issue discs of PDFs for readers wanting to maintain their own digital library. These will be available by mail order and also via the online shop as a matter of course, accessible from our website.

EPE continues to make good progress in what are challenging times for the publishing industry and the retail sector as a whole. We have come a long way since our first small, home-spun website of 1996, and we hope that most readers will approve of our wish to continually evolve in turbulent times and attract new readers through a digital newsstand.

Herding cats

In December 2012's issue of *Net Work*, I compared running a home wireless network to the frustrations of trying to herd cats. In my experience, a home Wi-Fi network seems to settle down for a while until a conflict of some kind knocks one device or another off the network, which gives rise to some re-configuring, setting up, re-booting, frustration and general cursing at times. Previously, I've recommended InSIDDER software from the heroes at Metageek (www.metageek.net) and this essential piece of free software lets you observe any Wi-Fi channels that are in use in your vicinity, so that you can at least try to choose a wireless channel in the hope of reducing interference from neighbours. In my case, I'm presently running on channel 13 (not suggested for the US), but the page on Metageek (www.metageek.net/support/why-channels-1-6-and-11) explains why they think channels 1, 6 or 11 are optimum for Wi-Fi users. You can change channel by logging into your browser's IP address using a web browser, and then aiming for the router's control panel to change the WLAN settings.

It seems that for many BT broadband packages, channel 6 is configured by default, and sure enough a neighbouring BT Wi-Fi network was using that channel, with another neighbour using channel 9 instead. A useful whitepaper *Optimising Wireless Networks* is published by Metageek, see: <http://tinyurl.com/cu6yp45> and further in-depth information on Wi-Fi channel topology can be found at: http://en.wikipedia.org/wiki/List_of_WLAN_channels.

The screenshot shows the BT Wi-Fi website interface. At the top, it says "You are connected to a BT Wi-Fi hotspot". Below that, there's a login section for BT or Fon customers with fields for email and password. For non-customer users, there are four purchase options:

Duration	Price	Details
1 hour	£3.50	Buy
1 day	£5	Just 21p per hour
5 days	£15	Just 13p per hour
30 days	£39	4000 minutes within 30 days

At the bottom, it promotes "The world's largest wi-fi network with over 7 million hotspots" and includes a "More" button.

BT will offer to sell local Wi-Fi hotspot access to non-BT-FON customers

I've noticed how those surprisingly powerful BT Home Hubs seem to be everywhere. Sniffing around on the local networks I thought it unimaginable that BT would offer a Wi-Fi hotspot in my location, but when I tested an unsecured open network that seemed to hail from a BT Home Hub, I was surprised to be greeted by a BT webpage offering to sell me BT hotspot access. Where did the Wi-Fi access come from? BT Fon is BT's

Wi-Fi hotspot network, consisting of BT broadband customers whom BT states 'share a small portion of their home broadband with other BT FON members. In return, users get free access to millions of other member's Wi-Fi Hotspots around the world'. An interactive map of BT Wi-Fi hotspots is at: <http://www.bt.com/static/wa/wifi/pages/findhotspots.html> with BT FON access highlighted in light blue. It appears not to zoom down to street level.

To see what networks are available to you on a wireless PC, in Microsoft Windows try right-clicking on the network icon in the system tray, then go View Available Wireless Networks and see if an unsecured BT network is broadcasting nearby. You can then try to connect directly to it, but if you try to open a web page a BT Wi-Fi hotspot sign-up page will be seen instead. At this stage, BT Wi-Fi access is granted sufficient for a sign-up to be made by BT and for you to download the T&C. In order to purchase, a MoPay page pops up and a text message must be sent from your mobile phone to confirm, and an email from 'FON Community' is used to confirm an account. I cancelled the sign-up and my laptop's web browser got stuck in a loop in protest.

A BT broadband customer's 'home Wi-Fi hotspot' is automatically enabled and BT FON hives off a portion of the customer's capacity when other BT FON users want to borrow it, says BT. The benefit is that BT customers can then draw from other BT Wi-Fi hotspots wherever they may be. In my example, the hotspot access could only have come from a residential neighbour's broadband because I recognised the SSID. It makes a lot of sense to distribute Wi-Fi access for the benefit of everybody this way, but it would appear that a portion of a BT user's broadband can be resold to non-BT FON users at anything from £3.50 per hour up to £39 for 4,000 minutes worth of access. The resale of Wi-Fi this way goes beyond the 'mutually beneficial club' of BT FON users suggested by BT. I'm not sure BT broadband users are aware of that.

The screenshot shows the BT Wi-Fi hotspot finder interface. It features a search bar with "bournemouth" entered and a "GO" button. Below the search bar, there's a map of Bournemouth with several purple "wifi" icons indicating hotspot locations. The map includes labels for various areas like Broadstone, Moordown, and Bournemouth. At the bottom, there's a "Map Key" and a "Find international hotspots" section.

Hotspot access is shown in the light blue areas: it's derived from BT FON broadband wireless hubs.

I hope you found something of interest in this month's *Net Work*. Readers can email me at alan@epemag.demon.co.uk or write to the editor at editorial@wimborne.co.uk. Don't forget to keep checking for the latest developments on our new website at: www.epemag.com.

ELECTRONICS TEACH-IN 4

ELECTRONICS TEACH-IN 4

A Broad-Based Introduction to Electronics plus **FREE CD-ROM**

The Teach-In 4 book covers three of the most important electronics units that are currently studied in many schools and colleges. These include, Edexcel BTEC level 2 awards and the electronics units of the new Diploma in Engineering, Level 2.

The Free cover-mounted CD-ROM contains the full Modern Electronics Manual, worth £29.95. The Manual contains over 800 pages of electronics theory, projects, data, assembly instructions and web links.

A package of exceptional value that will appeal to all those interested in learning about electronics or brushing up on their theory, be they hobbyists, students or professionals.

144 pages

Order code ET14

£8.99

FREE
CD-ROM

ROBOTICS

INTRODUCING ROBOTICS WITH LEGO MINDSTORMS Robert Penfold

Shows the reader how to build a variety of increasingly sophisticated computer controlled robots using the brilliant Lego Mindstorms Robotic Invention System (RIS). Initially covers fundamental building techniques and mechanics needed to construct strong and efficient robots using the various "click-together" components supplied in the basic RIS kit. Then explains in simple terms how the "brain" of the robot may be programmed on screen using a PC and "zapped" to the robot over an infra-red link. Also, shows how a more sophisticated Windows programming language such as Visual BASIC may be used to control the robots.

Detailed building and programming instructions provided, including numerous step-by-step photographs.

288 pages - large format

Order code BP901

£14.99

MORE ADVANCED ROBOTICS WITH LEGO MINDSTORMS - Robert Penfold

Shows the reader how to extend the capabilities of the brilliant Lego Mindstorms Robotic Invention System (RIS) by using lego's own accessories and some simple home constructed units. You will be able to build robots that can provide you with 'waiter service' when you clap your hands, perform tricks, 'see' and avoid objects by using 'bats radar', or accurately follow a line marked on the floor. Learn to use additional types of sensors including rotation, light, temperature, sound and ultrasonic and also explore the possibilities provided by using an additional (third) motor. For the less experienced, RCX code programs accompany most of the featured robots. However, the more adventurous reader is also shown how to write programs using Microsoft's VisualBASIC running with the ActiveX control (Spirit.OCX) that is provided with the RIS kit.

Detailed building instructions are provided for the featured robots, including numerous step-by-step photographs. The designs include rover vehicles, a virtual pet, a robot arm, an 'intelligent' sweet dispenser and a colour conscious robot that will try to grab objects of a specific colour.

198 pages

Order code BP902

£14.99

ANDROIDS, ROBOTS AND ANIMATRONS Second Edition - John Iovine

Build your own working robot or android using both off-the-shelf and workshop constructed materials and devices. Computer control gives these robots and androids two types of artificial intelligence (an expert system and a neural network). A lifelike android hand can be built and programmed to function doing repetitive tasks. A fully animated robot or android can also be built and programmed to perform a wide variety of functions.

The contents include an Overview of State-of-the-Art Robots; Robotic Locomotion; Motors and Power Controllers; All Types of Sensors; Tilt; Bump; Road and Wall Detection; Light; Speech and Sound Recognition; Robotic Intelligence (Expert Type) Using a Single-Board Computer Programmed in BASIC; Robotic Intelligence (Neutral Type) Using Simple Neural Networks (Insect Intelligence); Making a Lifelike Android Hand; A Computer-Controlled Robotic Insect Programmed in BASIC; Telepresence Robots With Actual Arcade and Virtual Reality Applications; A Computer-Controlled Robotic Arm; Animated Robots and Androids; Real-World Robotic Applications.

224 pages

Order code MGH1

£16.99

ELECTRONICS TEACH-IN BUNDLE - SPECIAL BUNDLE PRICE £14 FOR PARTS 1, 2 & 3

ELECTRONICS TEACH-IN 2 CD-ROM USING PIC MICROCONTROLLERS A PRACTICAL INTRODUCTION

This Teach-In series of articles was originally published in EPE in 2008 and, following demand from readers, has now been collected together in the *Electronics Teach-In 2* CD-ROM.

The series is aimed at those using PIC microcontrollers for the first time. Each part of the series includes breadboard layouts to aid understanding and a simple program project is provided.

Also included are 29 PIC N' Mix articles, also republished from EPE. These provide a host of practical programming and interfacing information, mainly for those that have already got to grips with using PIC microcontrollers. An extra four part beginners guide to using the C programming language for PIC microcontrollers is also included.

The CD-ROM also contains all of the software for the Teach-In 2 series and PIC N' Mix articles, plus a range of items from Microchip - the manufacturers of the PIC microcontrollers. The material has been compiled by Wimborne Publishing Ltd. with the assistance of Microchip Technology Inc.

The Microchip items are: MPLAB Integrated Development Environment V8.20; Microchip Advance Parts Selector V2.32; Treelink; Motor Control Solutions; 16-bit Embedded Solutions; 16-bit Tool Solutions; Human Interface Solutions; 8-bit PIC Microcontrollers; PIC24 Microcontrollers; PIC32 Microcontroller Family with USB On-The-Go; dsPIC Digital Signal Controllers.

CD-ROM

Order code ET12 CD-ROM

£9.50

160 pages

Order code ET13

£8.50

Book and CD-ROMs

Order code ETIBUNDLE

Bundle Price £14.00

FREE
CD-ROM

ELECTRONICS TEACH-IN 3

The three sections of this book cover a very wide range of subjects that will interest everyone involved in electronics, from hobbyists and students to professionals. The first 80-odd pages of Teach-In 3 are dedicated to *Circuit Surgery*, the regular EPE clinic dealing with readers' queries on various circuit design and application problems - everything from voltage regulation to using SPICE circuit simulation software.

The second section - *Practically Speaking* - covers the practical aspects of electronics construction. Again, a whole range of subjects, from soldering to avoiding problems with static electricity and identifying components, are covered. Finally, our collection of *Ingenuity Unlimited* circuits provides over 40 circuit designs submitted by the readers of EPE.

The free cover-mounted CD-ROM is the complete *Electronics Teach-In 1* book, which provides a broad-based introduction to electronics in PDF form, plus interactive quizzes to test your knowledge, TINA circuit simulation software (a limited version - plus a specially written TINA Tutorial), together with simulations of the circuits in the Teach-In 1 series, plus Flowcode (a limited version) a high level programming system for PIC microcontrollers based on flowcharts.

The Teach-In 1 series covers everything from Electric Current through to Microprocessors and Microcontrollers and each part includes demonstration circuits to build on breadboards or to simulate on your PC. There is also a MW/LW Radio project in the series. The contents of the book and Free CD-ROM have been reprinted from past issues of EPE.

COMPUTERS AND COMPUTING

NEW FREE DOWNLOADS TO PEP-UP AND PROTECT YOUR PC R. A. Penfold

Bob Penfold, uses his vast knowledge and experience in computing to guide you simply through the process of finding reliable sites and sources of free software that will help optimize the performance and protect your computer against most types of malicious attack.

Among the many topics covered are: Using Windows 7 optimization wizard; PCPitstop for advice on improving performance, reducing start up times, etc; Free optimization scans and the possibility of these being used as a ploy to attack your PC; Free programs such as Ccleaner, Registry checker and PCPal optimization software; Internet speed testing sites and download managers; Overclocking sites, together with warnings about using this technique; Sites and software for diagnosis of hardware faults, including scanning for out of date drivers and finding suitable replacements; Free Antivirus software and programs that combat specific types of malware; Firewalls; Search engines to identify mystery processes listed in Windows Task Manager.

128 pages

Order code BP722

£7.99

PROGRAMMING 16-BIT PIC MICROCONTROLLERS IN C - LEARNING TO FLY THE PIC24 Lucio Di Jasio

(Application Segments Manager, Microchip, USA)
A Microchip insider tells all. Focuses on examples and exercises that show how to solve common, real-world design problems quickly. Includes handy checklists to help readers perform the most common programming and debugging tasks. FREE CD-ROM includes source code in C, the Microchip C30 compiler, and MPLAB SIM software, so that readers gain practical, hands-on programming experience.

Until recently, PICs didn't have the speed and memory necessary for use in designs such as video- and audio-enabled devices. All that changed with the introduction

of the 16-bit PIC family, the PIC24. This new guide teaches readers everything they need to know about the architecture of these chips, how to program them, how to test them and how to debug them. Lucio's common-sense, practical, hands-on approach starts out with basic functions and guides the reader step-by-step through even the most sophisticated programming scenarios.

Experienced PIC users and newcomers alike will benefit from the text's many thorough examples, which demonstrate how to nimbly side-step common obstacles and take full advantage of all the 16-bit features.

496 pages +CD-ROM

Order code NE45

£38.00

THE INTERNET - TWEAKS, TIPS AND TRICKS R. A. Penfold

Bob Penfold, uses his vast knowledge and experience in computing to provide you with useful hints, tips and warnings about possible difficulties and pitfalls when using the Internet. This book should enable you to get more from the Internet and to discover ways and means of using it that you may not have previously realised.

Among the many topics covered are: Choosing a suitable browser, getting awkward pages to display properly; Using Java, spell checkers and other add-ons, etc; Using proxy servers to surf anonymously and privacy facilities so you do not leave a trail of sites visited; Ways of finding recently visited sites you can no longer find; Using download managers to speed up downloads from slow servers; Effective ways and tricks of using search engines to locate relevant info; Tricks and tips on finding the best price for goods and services; Not getting 'conned' when buying or selling on eBay; Finding free software; Finding and using the increasing range of Cloud computing services; Tips on selecting the best security settings; Etc.

128 pages

Order code BP721

£7.99

RADIO

BASIC RADIO PRINCIPLES AND TECHNOLOGY Ian Poole

Radio technology is becoming increasingly important in today's high technology society. There are the traditional uses of radio which include broadcasting and point to point radio as well as the new technologies of satellites and cellular phones. All of these developments mean there is a growing need for radio engineers at all levels.

Assuming a basic knowledge of electronics, this book provides an easy to understand grounding in the topic.

Chapters in the book: Radio Today, Yesterday, and Tomorrow; Radio Waves and Propagation; Capacitors, Inductors, and Filters; Modulation; Receivers; Transmitters; Antenna Systems; Broadcasting; Satellites; Personal Communications; Appendix - Basic Calculations.

263 pages

Order code NE30

£28.99

DIRECT BOOK SERVICE

3 All prices include UK postage

The books listed have been selected by *Everyday Practical Electronics* editorial staff as being of special interest to everyone involved in electronics and computing. They are supplied by mail order direct to your door. Full ordering details are given on the last book page.

FULL COLOUR COMPUTING BOOKS

WINDOWS 7 – TWEAKS, TIPS AND TRICKS Andrew Edney

This book will guide you through many of the exciting new features of Windows 7. Microsoft's latest and greatest operating system. It will provide you with useful hints, tips and warnings about possible difficulties and pitfalls. This book should enable you to get much more out of Windows 7 and, hopefully, discover a few things that you may not have realised were there.

Among the topics covered are: A brief overview of the various versions of Windows 7. How to install and use Upgrade Advisor, which checks to see if your computer meets the minimum requirements to run Windows 7 and that your software and drivers are supported by Windows 7. How to use Windows Easy Transfer to migrate your data and settings from your Vista or XP machine to your new Windows 7 computer. Exploring Windows 7 so that you will become familiar with many of its new features and then see how they contrast with those of earlier versions of Windows. How to connect to a network and create and use Home Groups to easily share your pictures, videos, documents, etc., with the minimum of hassle. Why Windows Live Essentials is so useful and how to download and install it. A brief introduction to Windows Media Center. The use of Action Center, which reports security and maintenance incidents. Windows Memory Diagnostic to detect the fairly common problem of faulty memory and Troubleshooting tools.

120 pages

Order code BP708 £8.49

HOW TO BUILD A COMPUTER MADE EASY R.A. Penfold

Building your own computer is a much easier than most people realise and can probably be undertaken by anyone who is reasonably practical. However, some knowledge and experience of using a PC would be beneficial. This book will guide you through the entire process. It is written in a simple and straightforward way with the explanations clearly illustrated with numerous colour photographs.

The book is divided into three sections: *Overview and preparation* – Covers understanding the fundamentals and choosing the most suitable component parts for your computer, together with a review of the basic assembly. *Assembly* – Explains in detail how to fit the component parts into their correct positions in the computer's casing, then how to connect these parts together by plugging the cables into the appropriate sockets. No soldering should be required and the only tools that you are likely to need are screwdrivers, small spanners and a pair of pliers.

BIOS and operating system – This final section details the setting up of the BIOS and the installation of the Windows operating system, which should then enable all the parts of your computer to work together correctly. You will then be ready to install your files and any application software you may require.

The great advantage of building your own computer is that you can 'tailor' it exactly to your own requirements. Also, you will learn a tremendous amount about the structure and internal workings of a PC, which will prove to be invaluable should problems ever arise.

120 pages

Order code BP707 £8.49

AN INTRODUCTION TO eBay FOR THE OLDER GENERATION Cherry Nixon

eBay is an online auction site that enables you to buy and sell practically anything from the comfort of your own home. eBay offers easy access to the global market at an amazingly low cost and will enable you to turn your clutter into cash.

This book is an introduction to eBay.co.uk and has been specifically written for the over 50s who have little knowledge of computing. The book will, of course, also apply equally to all other age groups. The book contains ideas for getting organised for long term safe and successful trading. You will learn how to search out and buy every conceivable type of thing. The book also shows you how to create auctions and add perfect pictures. There is advice on how to avoid the pitfalls that can befall the inexperienced.

Cherry Nixon is probably the most experienced teacher of eBay trading in the UK and from her vast experience has developed a particular understanding of the issues and difficulties normally encountered by individuals.

So, if you are new to computers and the internet and think of a mouse as a rodent, then this is the book for you!

120 pages

Order code BP709 £8.49

GETTING STARTED IN COMPUTING FOR THE OLDER GENERATION Jim Gatenby

You can learn to use a computer at any age and this book will help you achieve this. It has been especially written for the over 50s, using plain English and avoiding technical jargon wherever possible. It is lavishly illustrated in full colour.

Among the many practical and useful subjects that are covered in this book are: Choosing the best computing system for your needs. Understanding the main hardware components of your computer. Getting your computer up and running in your home. Setting up peripheral devices like printers and routers. Connecting to the internet using wireless broadband in a home with one or more computers. Getting familiar with Windows Vista and XP the software used for operating and maintaining your computer. Learning about Windows built-in programs such as Windows Media Player, Paint and Photo Gallery.

Plus, using the Ease of Access Center to help if you have impaired eyesight, hearing or dexterity problems. Installing and using essential software such as Microsoft Office suite. Searching for the latest information on virtually any subject. Keeping in touch with friends and family using e-mail. Keeping your computer running efficiently and your valuable data files protected against malicious attack.

This book will help you to gain the basic knowledge needed to get the most out of your computer and, if you so wish, give you the confidence to even join a local computer class.

120 pages

Order code BP704 £8.49

THEORY AND REFERENCE

ELECTRONIC CIRCUITS – FUNDAMENTALS & APPLICATIONS Third Edition Mike Tooley

Third Edition

Mike Tooley

A comprehensive reference text and practical electronics handbook in one volume – at an affordable price!

New chapter on PIC microcontrollers – the most popular chip family for use in project work by hobbyists and in colleges and universities.

New companion website: spreadsheet design tools to simplify circuit calculations; circuit models and templates to enable virtual simulation; a bank of on-line questions for lecturers to set as assignments, and on-line self-test multiple choice questions for each chapter with automatic marking, to enable students to continually monitor their progress and understanding.

The book's content is matched to the latest pre-degree level courses, making this an invaluable reference for all study levels, and its broad coverage is combined with practical case studies, based in real-world engineering contexts throughout the text.

The unique combination of a comprehensive reference text, incorporating a primary focus on practical applications, ensures this text will prove a vital guide for students and also for industry-based engineers, who are either new to the field of electronics, or who wish to refresh their knowledge.

400 pages

Order code NE43 £25.99

BEBOP TO THE BOOLEAN BOOGIE Third Edition Clive (Max) Maxfield

Third Edition
Clive (Max) Maxfield

This book gives the 'big picture' of digital electronics. This in-depth, highly readable, guide shows you how electronic devices work and how they're made. You'll discover how transistors operate, how printed circuit boards are fabricated, and what the innards of memory ICs look like. You'll also gain a working knowledge of Boolean Algebra and Karnaugh Maps, and understand what Reed-Muller logic is and how it's used. And there's much, MUCH more. The author's tongue-in-cheek humour makes it a delight to read, but this is a REAL technical book, extremely detailed and accurate.

Contents: Fundamental concepts; Analog versus digital; Conductors and insulators; Voltage, current, resistance, capacitance and inductance; Semiconductors; Primitive logic functions; Binary arithmetic; Boolean algebra; Karnaugh maps; State diagrams, tables and machines; Analog-to-digital and digital-to-analog; Integrated circuits (ICs); Memory

ICs; Programmable ICs; Application-specific integrated circuits (ASICs); Circuit boards (PWBs and DWBs); Hybrids; Multichip modules (MCMs); Alternative and future technologies.

500 pages

Order code BEB1 £32.99

BEBOP BYTES BACK (and the Bebopter Computer Simulator) CD-ROM

Clive (Max) Maxfield and Alvin Brown

This follow-on to *Bebop to the Boolean Boogie* is a multimedia extravaganza of information about how computers work. It picks up where "Bebop I" left off, guiding you through the fascinating world of computer design . . . and you'll have a few chuckles, if not belly laughs, along the way. In addition to over 200 megabytes of mega-cool multimedia, the CD-ROM contains a virtual microcomputer, simulating the motherboard and standard computer peripherals in an extremely realistic manner. In addition to a wealth of technical information, myriad nuggets of trivia, and hundreds of carefully drawn illustrations, the CD-ROM contains a set of lab experiments for the virtual microcomputer that let you recreate the experiences of early computer pioneers. If you're the slightest bit interested in the inner workings of computers, then don't dare to miss this!

Over 800 pages in Adobe Acrobat format

CD-ROM Order code BEB2 CD-ROM £21.95

FUNDAMENTAL ELECTRICAL AND ELECTRONIC PRINCIPLES Third Edition C. R. Robertson

Third Edition
C. R. Robertson

Covers the essential principles that form the foundations for electrical and electronic engineering courses. The coverage of this new edition has been carefully brought in line with the core unit 'Electrical and Electronic Principles' of the 2007 BTEC National Engineering specification. This qualification from Edexcel attracts more than 10,000 students per year.

The book explains all theory in detail and backs it up with numerous worked examples. Students can test their

understanding with end of chapter assignment questions for which answers are provided. In this new edition, the layout has been improved and colour has been added. A free companion website with additional worked examples and chapters is also available.

368 pages

Order code NE47 £21.99

STARTING ELECTRONICS – 4th Edition Keith Brindley

4th Edition
Keith Brindley

Starting Electronics is unrivalled as a highly practical introduction for technicians, non-electronic engineers, software engineers, students, and hobbyists. Keith Brindley introduces readers to the functions of the main component types, their uses, and the basic principles of building and designing electronic circuits. Breadboard layouts make this very much a ready-to-run book for the experimenter, and the use of readily available, inexpensive components makes this practical exploration of electronics easily accessible to all levels of engineer and hobbyist.

Other books tell readers what to do, but sometimes fail to explain why - Brindley gives readers hands-on confidence in addition to real scientific knowledge, and insight into the principles as well as the practice. All written explanations and steps are supplemented with numerous photos, charts, tables and graphs. Concepts and practical aspects are explained thoroughly with mathematical formulae and technical schematic drawings.

Each chapter introduces a concept or tool, explains the basic theory, and provides clear instructions for a simple experiment to apply the concept or tool, with quiz sections and answers, at the end of each chapter.

296 pages

Order code NE100 £18.99



MUSIC, AUDIO AND VIDEO

MAKING MUSIC WITH YOUR COMPUTER

Stephen Bennett

Nearly everyone with musical aspirations also has a computer. This same computer can double as a high quality recording studio capable of producing professional recordings. This book tells you what software and hardware you will need to get the best results.

You'll learn about recording techniques, software and effects, mixing, mastering and CD production.

Suitable for PC and Mac users, the book is full of tips, "how to do" topics and illustrations. It's the perfect answer to the question "How do I use my computer to produce my own CD?"

92 pages

Order code PC120

£10.95



QUICK GUIDE TO MP3 AND DIGITAL MUSIC

Ian Waugh

MP3 files, the latest digital music format, have taken the music industry by storm. What are they? Where do you get them? How do you use them? Why have they thrown record companies into a panic? Will they make music easier to buy? And cheaper? Is this the future of music?

All these questions and more are answered in this concise and practical book which explains everything you need to know about MP3s in a simple and easy-to-understand manner. It explains:

How to play MP3s on your computer; How to use MP3s with handheld MP3 players; Where to find MP3s on the Web; How MP3s work; How to tune into Internet radio stations; How to create your own MP3s; How to record your own CDs from MP3 files; Other digital audio music formats.

Whether you want to stay bang up to date with the latest music or create your own MP3s and join the on-line digital music revolution, this book will show you how.

60 pages

Order code PC119

£7.45

DIGITAL AUDIO RECORDING

Ian Waugh

All modern music recordings use digital audio technology. Now everyone with a computer can produce CD-quality recordings and this book shows you how.

Written in a clear and straightforward style, it explains what digital audio recording is, how to use it, the equipment you need, what sort of software is available, and how to achieve professional results.

It explains:

- What computer system you need
- Sound and digital audio essentials
- What to look for in a sound card
- What effects to use
- The art of mixing
- Recording techniques
- How to use virtual instruments
- How to edit audio and create loops

Computer-based recording is the future of music and this book shows how you can join the revolution now.

60 pages

Order code PC121

£7.95

RADIO BYGONES

We also carry a selection of books aimed at readers of *EPE's* sister magazine on vintage radio *Radio Bygones*. These books include, the four volumes of our own *Wireless For the Warrior* by Louis Meulstee. These are a technical history of radio communication equipment in the British Army and clandestine equipment from pre-war through to the 1960s.

For details see the Online shop on our web site at www.epemag.com or contact us for a list of *Radio Bygones* books.

PROJECT BUILDING AND TESTING

ELECTRONIC PROJECT BUILDING FOR BEGINNERS

R. A. Penfold

This book is for complete beginners to electronic project building. It provides a complete introduction to the practical side of this fascinating hobby, including the following topics:

Component identification, and buying the right parts; resistor colour codes, capacitor value markings, etc; advice on buying the right tools for the job; soldering; making easy work of the hard wiring; construction methods, including stripboard, custom printed circuit boards, plain matrix boards, surface mount boards and wire-wrapping; finishing off, and adding panel labels; getting "problem" projects to work, including simple methods of fault-finding.

In fact everything you need to know in order to get started in this absorbing and creative hobby.

135 pages

Order code BP392

£5.99

BUILDING VALVE AMPLIFIERS

Morgan Jones

The practical guide to building, modifying, fault-finding and repairing valve amplifiers. A hands-on approach to valve electronics – classic and modern – with a minimum of theory. Planning, fault-finding, and testing are each illustrated by step-by-step examples.

A unique hands-on guide for anyone working with valve (tube in USA) audio equipment – as an electronics experimenter, audiophile or audio engineer.

Particular attention has been paid to answering questions commonly asked by newcomers to the world of the vacuum tube, whether audio enthusiasts tackling their first build, or more experienced amplifier designers seeking to learn the ropes of working with valves. The practical side of this book is reinforced by numerous clear illustrations throughout.

368 pages

Order code NE40

£29.00

PRACTICAL FIBRE-OPTIC PROJECTS

R. A. Penfold

While fibre-optic cables may have potential advantages over ordinary electric cables, for the electronics enthusiast it is probably their novelty value that makes them worthy of exploration. Fibre-optic cables provide an innovative interesting alternative to electric cables, but in most cases they also represent a practical approach to the problem. This book provides a number of tried and tested circuits for projects that utilize fibre-optic cables.

The projects include:- Simple audio links, F.M. audio link, P.W.M. audio links, Simple d.c. links, P.W.M. d.c. link, P.W.M. motor speed control, RS232C data links, MIDI link, Loop alarms, R.P.M. meter.

All the components used in these designs are readily available, none of them require the constructor to take out a second mortgage.

132 pages

Order code BP374

£5.45

GETTING THE MOST FROM YOUR MULTIMETER

R. A. Penfold

This book is primarily aimed at beginners and those of limited experience of electronics. Chapter 1 covers the basics of analogue and digital multimeters, discussing the relative merits and the limitations of the two types. In Chapter 2 various methods of component checking are described, including tests for transistors, thyristors, resistors, capacitors and diodes. Circuit testing is covered in Chapter 3, with subjects such as voltage, current and continuity checks being discussed.

In the main little or no previous knowledge or experience is assumed. Using these simple component and circuit testing techniques the reader should be able to confidently tackle servicing of most electronic projects.

102 pages

Order code BP239

£5.49

FOR A FURTHER SELECTION OF BOOKS SEE THE NEXT TWO ISSUES OF EPE

BOOK ORDERING DETAILS

All prices include UK postage. For postage to Europe (air) and the rest of the world (surface) please add £3 per book. Surface mail can take up to 10 weeks to some countries. For the rest of the world airmail add £4 per book. CD-ROM prices include VAT and/or postage to anywhere in the world. Send a PO, cheque, international money order (£ sterling only) made payable to **Direct Book Service** or card details, Visa, Mastercard or Maestro to: **DIRECT BOOK SERVICE, WIMBORNE PUBLISHING LIMITED, 113 LYNWOOD DRIVE, MERLEY, WIMBORNE, DORSET BH21 1UU.**

Books are normally sent within seven days of receipt of order, but please allow 28 days for delivery – more for overseas orders. Please check price and availability (see latest issue of *Everyday Practical Electronics*) before ordering from old lists.

For a further selection of books see the next two issues of *EPE*.

Tel 01202 880299 Fax 01202 843233. E-mail: dbs@wimborne.co.uk

Order from our online shop at: www.epemag.com – go to the Online shop

BOOK ORDER FORM

Full name:

Address:

.....

.....

..... Post code: Telephone No:

Signature:

I enclose cheque/PO payable to DIRECT BOOK SERVICE for £

Please charge my card £ Card expiry date.....

Card Number Maestro Issue No.....

Valid From Date Card Security Code (The last three digits on or just below the signature strip)

Please send book order codes:

.....

Please continue on separate sheet of paper if necessary

PCB SERVICE

CHECK US OUT ON THE WEB



Printed circuit boards for most recent *EPE* constructional projects are available from the *PCB Service*, see list. These are fabricated in glass fibre, and are fully drilled and roller tinned. Double-sided boards are **NOT plated through hole** and will require 'vias' and some components soldering to both sides. All prices include VAT and postage and packing. Add £2 per board for airmail outside of Europe. Remittances should be sent to **The PCB Service, Everyday Practical Electronics, Wimborne Publishing Ltd., 113 Lynwood Drive, Merley, Wimborne, Dorset BH21 1UU. Tel: 01202 880299; Fax 01202 843233; Email: orders@epemag.wimborne.co.uk. On-line Shop: www.epemag.com.** Cheques should be crossed and made payable to *Everyday Practical Electronics (Payment in £ sterling only)*.

NOTE: While 95% of our boards are held in stock and are dispatched within seven days of receipt of order, please allow a maximum of 28 days for delivery – overseas readers allow extra if ordered by surface mail.

Back numbers or photocopies of articles are available if required – see the Back Issues page for details. WE DO NOT SUPPLY KITS OR COMPONENTS FOR OUR PROJECTS.

PROJECT TITLE	ORDER CODE	COST
JANUARY '12		
Balanced Output Board For The Stereo DAC	833	£9.72
FEBRUARY '12		
★ Air Quality Monitor (CO ₂ /CO)	834	£8.75
WIB Connector Daughter PCB	835	£6.80
MARCH '12		
★ Internet Time Display Module	836	£8.16
Solar-Powered Intruder Alarm	837	£9.33
★ Very, Very Accurate Thermometer/Thermostat	840	£9.33
APRIL '12		
★ Digital Audio Signal Generator		
– Main Board (Jay or Alt)	838	} pair £18.86
– Control/Display Board	839	
EHT Stick	841	£9.15
Capacitor Leakage Adaptor For DMMs	842	£9.72
MAY '12		
High-Performance 12V Stereo Amplifier	843	£9.14
Low-Power Car/Bike USB Charger	844	£7.58
★ Solar-Powered Lighting Controller	845	£9.91
Jump Start	846	£7.97
– Plant Pot Moisture Sensor		
– Rain Alarm (Main)	847	} pair £15.36
– Rain Alarm (Sensor)	848	
JUNE '12		
★ Digital Insulation Meter		
– Main/Display	849	} pair £16.33
– DC-DC Converter	850	
Dual Tracking ±0V to 19V PSU		
– Main PCB	851	£9.33
– Front Panel	852	£8.16
– LCD Meter	853	£7.19
Jump Start Quiz Machine		
– Master	854	£7.39
– Contestant	855	£7.39
JULY '12		
★ 16-Bit Digital Potentiometer	856	£13.99
★ Intelligent 12V Fan Controller	857	£10.10
Jump Start – Battery Voltage Checker	858	£9.14
AUGUST '12		
High Performance Microphone Pre-amplifier	859	£7.58
Jump Start – Solar Powered Charger	860	£7.20
★ Electrolytic Capacitor Reformer And Tester	861	£16.71
★ Ultrasonic Cleaner	862	£8.75
High-power DC Motor Speed Controller		
– Non-Reversible	863	£6.50
– Reversible	864	£6.75
(Both boards double-sided)		
SEPTEMBER '12		
Hearing Loop Receiver	865	£8.55
★ Ultrasonic Anti-Fouling For Boats	866	£9.14
Jump Start – Versatile Theft Alarm	867	£9.33
OCTOBER '12		
S/PDIF To TOSLINK Converter	868	£8.16
TOSLINK to S/PDIF Converter	869	£8.16
★ Digital Lighting Controller		
– Master Board	870	£12.05
– Slave Board	871	£16.72
Jump Start – Crazy Eyes	872	£7.78
– Ghostly Sounds	873	£8.16

PROJECT TITLE	ORDER CODE	COST
NOVEMBER '12		
Hearing Loop Level Meter	874	£9.53
RFID Security System	875	£7.75
Jump Start – Frost Alarm	876	£8.55
DECEMBER '12		
Hot Wire Cutter – Controller	877	£8.55
★ Universal USB Data Logger – Part 1 (double-sided)	878	£16.52
Jump Start – Mini Christmas Lights	879	£10.69
JANUARY '13		
Low-Capacitance Adaptor for DMMs	880	£8.55
★ 3-Input Stereo Audio Switcher		
– Main Board	881	} pair £20.00
– Switch Board	882	
Stereo Compressor – Main Board	883	£12.63
Jump Start – iPod Speaker	884	£8.16
FEBRUARY '13		
10W LED Floodlight	885	£6.75
★ Crystal DAC (double-sided)	886	£18.46
Jump Start – Logic Probe	887	£6.42
MARCH '13		
Lightning Detector	888	£8.75
★ Digital Spirit Level	889	£8.75
★ Semtest – Part 2		
– Main/Lower Board	890	£16.52
– Display/Upper Board	891	£15.55
Interplanetary Voice	892	£8.75
Jump Start – DC Motor Controller	893	£8.55

Please check price and availability in the latest issue. A large number of older boards are listed on, and can be ordered from, our website.

Boards can only be supplied on a payment with order basis.

EPE SOFTWARE

★ All software programs for *EPE* Projects marked with a star, and others previously published can be downloaded free from the Library on our website, accessible via our home page at: www.epemag.com

PCB MASTERS

PCB masters for boards published from the March '06 issue onwards can also be downloaded from our website (www.epemag.com); go to the 'Library' section.

EPE PRINTED CIRCUIT BOARD SERVICE

Order Code	Project	Quantity	Price
.....
Name
Address
.....
Tel. No.
I enclose payment of £..... (cheque/PO in £ sterling only) to:			
Everyday Practical Electronics			
  			
Card No.
Valid From	Expiry Date
Card Security No.	Maestro Issue No.
Signature
Note: You can also order PCBs by phone, Fax or Email or via the Shop on our website on a secure server:			
http://www.epemag.com			



CLASSIFIED

ADVERTISEMENTS

If you want your advertisements to be seen by the largest readership at the most economical price our classified page offers excellent value. The rate for semi-display space is £10 (+VAT) per centimetre high, with a minimum height of 2.5cm. All semi-display adverts have a width of 5.5cm. The prepaid rate for classified adverts is 40p (+VAT) per word (minimum 12 words).

All cheques, postal orders, etc., to be made payable to Everyday Practical Electronics. **VAT must be added.** Advertisements, together with remittance, should be sent to Everyday Practical Electronics Advertisements, 113 Lynwood Drive, Merley, Wimborne, Dorset, BH21 1UU. Phone: 01202 880299. Fax: 01202 843233. Email: stewart.kearn@wimborne.co.uk. For rates and information on display and classified advertising please contact our Advertisement Manager, Stewart Kearn as above.

BOWOOD ELECTRONICS LTD

Suppliers of Electronic Components

Place a secure order on our website or call our sales line
All major credit cards accepted
Web: www.bowood-electronics.co.uk
Unit 10, Boythorpe Business Park, Dock Walk, Chesterfield,
Derbyshire S40 2QR. Sales: 01246 200222
Send 60p stamp for catalogue

**AUDIO TRANSFORMERS for
OBSOLETE & VINTAGE
EQUIPMENT**

For full info Visit Section 4C
www.partridgeelectronics.co.uk

CPS Solar

Solar panels, solar cells, and many more alternative energy products for battery charging etc, please visit our website for further info or call
Tel: 0870 765 2334.
www.solarpanelsonline.co.uk

MISCELLANEOUS

VALVES AND ALLIED COMPONENTS IN STOCK. Phone for free list. Valves, books and magazines wanted. Geoff Davies (Radio), tel. 01788 574774.

Everyday Practical Electronics reaches more UK readers than any other UK monthly hobby electronics magazine, our sales figures prove it.

We have been the leading monthly magazine in this market for the last twenty-five years.

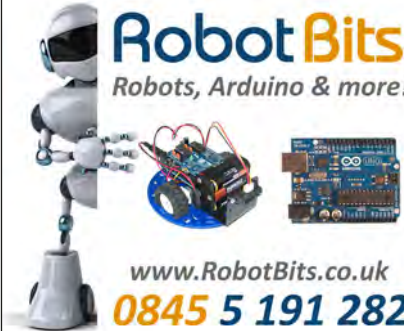

Robot Bits
Robots, Arduino & more!
www.RobotBits.co.uk
0845 5 191 282

BTEC ELECTRONICS TECHNICIAN TRAINING

**NATIONAL ELECTRONICS
VCE ADVANCED ICT
HNC AND HND ELECTRONICS
FOUNDATION DEGREES
NVQ ENGINEERING AND IT
DESIGN AND TECHNOLOGY**

**LONDON ELECTRONICS COLLEGE
20 PENYWERN ROAD
EARLS COURT, LONDON SW5 9SU
TEL: (020) 7373 8721
www.lec.org.uk**

CANTERBURY WINDINGS

UK manufacturer of toroidal transformers
(10VA to 3kVA)
All transformers made to order. No design fees.
No minimum order.
www.canterburywindings.co.uk
01227 450810

If you would like to advertise on this Classified page then please call

Stewart Kearn on:

01202 880299

ADVERTISERS INDEX

BETA LAYOUT	69	QUASAR ELECTRONICS	2/3
COAST ELECTRONICS	59	RK EDUCATION	37
CRICKLEWOOD ELECTRONICS	80	SHERWOOD ELECTRONICS	37
ESR ELECTRONIC COMPONENTS	6	STEWART OF READING	Cover (iii)
JAYCAR ELECTRONICS	4/5		
JPG ELECTRONICS	80		
L-TEK POSCOPE	67		
LABCENTER	Cover (iv)		
LASER BUSINESS SYSTEMS	59		
MICROCHIP	Cover (ii)		
MIKROELEKTRONIKA	63		
PEAK ELECTRONIC DESIGN	Cover (iii)		
PICO TECHNOLOGY	37		

ADVERTISEMENT OFFICES:

113 LYNWOOD DRIVE, MERLEY, WIMBORNE,
DORSET BH21 1UU

PHONE: 01202 880299

FAX: 01202 843233

EMAIL: stewart.kearn@wimborne.co.uk

WEB: www.epemag.com

For editorial address and phone numbers see page 7

Next Month

Content may be subject to change

SoftStarter: Taming The Surge Current Menace!

Are you alarmed by the juicy 'splatt' from your mains power point when you plug in something like a large plasma TV set? Do you sometimes burn out light and power point switches because of the surge currents at switch-on? This is a common problem, but there is a simple cure: our SoftStarter. It tames those nasty surge currents, while having no effect on appliance performance.

Cheap High-Current Bench Power Supply

If you've ever had to buy a high-current bench supply, you'll know they don't come cheap. But you may well have such a supply sitting unloved and unwanted in the back of a cupboard. It's the power supply in that old computer you never quite got around to throwing away!

6-Decade Resistance Substitution Box

Get a million resistance values with this compact 6-decade resistance box using readily available rotary switches and 1% metal film resistors, all mounted on a PCB to make assembly a cinch.

SemTest: A Discrete Semiconductor Test Set – Part 3

We've looked at the full circuit of our new Discrete Semiconductor Test Set (SemTest), so now it's time to describe its construction and set up. We also describe how to fit a crowbar circuit to quickly discharge the HT after making high-voltage measurements.

Jump Start – Egg Timer

Fancy a nice little timer project? Well, we have just the right circuit for you – meet the Jump Start Egg Timer; perfect boiled eggs for breakfast guaranteed! A fun and easy project aimed at all levels of experience. This will be Mike and Richard Tooley's twelfth project in our series dedicated to newcomers, or those following courses taught in schools and colleges.



APRIL '13 ISSUE ON SALE 7 MARCH 2013

Rechargeable Batteries With Solder Tags

NIMH		NICAD	
AA 2000mAh	£2.82	AA 650mAh	£1.41
C 4Ah	£4.70	C 2.5Ah	£3.60
D 9Ah	£7.60	D 4Ah	£4.95
PP3 150mAh	£4.95		

Instrument case with edge connector and screw terminals

Size 112mm x 52mm x 105mm tall

This box consists of a cream base with a PCB slot, a cover plate to protect your circuit, a black lid with a 12 way edge connector and 12 screw terminals built in (8mm pitch) and 2 screws to hold the lid on. The cream bases have minor marks from dust and handling price £2.00 + VAT(=£2.35) for a sample or £44.00+VAT (=£51.70) for a box of 44.

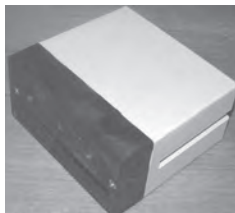

866 battery pack originally intended to be used with an orbitel mobile telephone it contains 10 1.6Ah sub C batteries (42 x 22 dia. the size usually used in cordless screwdrivers etc.) the pack is new and unused and can be broken open quite easily £7.46 + VAT = £8.77



Please add £1.66 + VAT = £1.95 postage & packing per order

JPG Electronics

Shaws Row, Old Road, Chesterfield, S40 2RB.

Tel 01246 211202 Fax 01246 550959

www.JPGElectronics.com

Mastercard/Visa/Switch

Callers welcome 9.30 a.m. to 5.30 p.m. Monday to Saturday

e CRICKLEWOOD ELECTRONICS

Established 1981



Frustrated with your supplier? Visit our component packed website for a vast range of parts - old and new, many unavailable elsewhere! www.cricklewoodelectronics.com

1000's OF PRICES REDUCED!

Alternatively phone us on 020 8452 0161 with your requirements.



Visit our Shop, Call or Buy online at: www.cricklewoodelectronics.com

020 8452 0161 Visit our shop at: 40-42 Cricklewood Broadway London NW2 3ET



UK designed,
UK made,
with pride.

Tel. 01298 70012
www.peakelec.co.uk
sales@peakelec.co.uk

Atlas House, 2 Kiln Lane
Harpur Hill Business Park
Buxton, Derbyshire
SK17 9JL, UK

Follow us on twitter
for tips, tricks and
news.
@peakatlas

For insured UK delivery:
Please add £3.00 inc VAT
to the whole order.
Check online or
give us a call for
overseas pricing.

PEAK[®]
electronic design ltd



The new *DCA Pro* ... is now shipping!

As a result of a major product development initiative at Peak Electronic Design Ltd, we are delighted to make this exciting announcement.

£115.95
(£96.62+VAT)

The amazing new *DCA Pro* is now available!

- Just connect your component any way round.
- Graphic display shows detailed component schematics.
- Enhanced component identification, pinout identification and analysis including gain, transconductance, pinch-off, etc.
- USB connectivity for power and communications.
- PC Software included on Peak USB Stick.
- Can be used standalone or with a PC (Win XP or later).
- Curve tracing functions on your PC. (up to ±12V / ±12mA).
- Supports Transistors, MOSFETs, JFETs, IGBTs, Diodes, Zeners, LEDs, Voltage Regulators and much more!
- Free updates online for PC Software and Firmware.
- Uses a single Alkaline AAA battery (and/or USB power).

We aim to despatch your order as soon as possible. Demand for the *DCA Pro* is currently very high and that may cause a small delay. We will contact you immediately to confirm expected despatch date and you can cancel at any time of course.



USB cable included

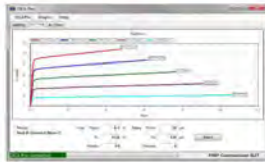

Curve tracing on your PC!



Detailed specs on your PC

It's only possible to show summary specifications here. Please ask if you'd like detailed data. Further information is also available on our website. Product price refunded if you're not happy.

www.stewart-of-reading.co.uk

Check out our website, 1,000's of items in stock.



HP8560E SPECTRUM ANALYSER
30HZ-2.9GHZ with Tracking Generator
£3,500

HP8560 SERIES SPECTRUM ANALYSER Frequency up to 26GHZ
Various Models from £2,500-£7,000



HP83731A/B SYNTHESISED SIGNAL GENERATOR
1-20GHZ Various Options
£4,000-5,000



TEKTRONIX TDS784D
4 Channel 1GHz 4GS/S
Opts 05/1M/2M/2C/3C/4C no Probes
£2,750

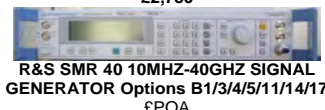

R&S SMR 40 10MHZ-40GHZ SIGNAL GENERATOR Options B1/3/4/5/11/14/17
£POA

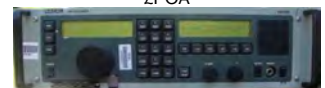

RACAL 1792 RECEIVER
£300

AGILENT E4402B Spectrum Analyser
100HZ - 3GHZ with Option 1DN Tracking
Gen; 1 DR Narrow Res; A4H GPIB,
UKB.....£5800
HP 35670A FFT Dynamic Signal Analyser
2 Channel. Unused in original box...£4000
AGILENT 83752B Synthesised Sweeper
0.01-20GHZ.....£6000
HP83711B Synthesised 1-20GHZ with
Opt I/E Attenuator.....£5000
AGILENT/HP E4431B Signal Generator
250KHZ-2GHZ Digital Modulation...£2750
MARCONI 2024 Signal Generator 9KHZ-
2.4GHZ Opt 04.....£1250
MARCONI/IFR 2030 Signal Generator
10KHZ-1.35 GHz.....£995
MARCONI 2022E Synthesised AM/FM
Signal Generator 10KHZ-1.01GHZ...£500
HP8566A Spectrum Analyser 100HZ-
22GHZ.....£1950
HP8568A Spectrum Analyser 100HZ-
1500MHZ.....£1250
AVCOM PSA-37D Spectrum Analyser
1MHZ-4.2GHZ.....£-
IFR 1200S Service Communication
Monitor.....£1500
HP6624A Power Supply 0-20V 0-2A
Twice, 0-7V 0-5A; 0-50V 0.8A
Special price.....£350
AVO/MEGGAR FT6/12 AC/DC
breakdown tester.....£400-£600
MARCONI/IFR/AEROFLEX 2025 Signal
Gen 9KHZ-2.51GHZ Opt 04 High Stab
Opt 11 High Power etc As New.....£2500
SOLARTRON 1250 Frequency Response
Analyser 10uHZ-65KHZ.....£995
HP3324A Synthesised Function
Generator 21MHZ.....£500
HP41800A Active Probe 5HZ-500MHZ
.....£750
ANRITSU MS2601A Spectrum Analyser
10KHZ-2.2GHZ 50ohm.....£750
AGILENT E4421B 250KHZ-3GHZ
Signal Generator.....£2500

HP53131A Universal Counter Opt 001
Unused Boxed 3GHZ.....£850
Unused Boxed 225MHZ.....£595
Used 225MHZ.....£495
HP8569B Spectrum Analyser 0.01-
22GHZ.....£995
HP54616C Oscilloscope Dual Trace
500MHZ 2GS/S Colour.....£1250
QUART LOCK 10A-R Rubidium
Frequency Standard.....£1000
PENDULUM CNT90 Timer/Counter
/Analyser 20GHZ.....£1950
ADVANTEST R3465 Spectrum
Analyser 9KHZ-8GHZ.....£-
HP Programmable Attenuators £300
each
33320H DC-18GHZ 11db
33321G DC-18GHZ 70db
Many others available
AGILENT E3610A Power Supply 0-8v
0-3A/0-15v 0-2A Unused
AGILENT E3611A Power Supply 0-20V
0-1.5A/0-35V 0-0.85V Unused
HP6269B Power Supply 0-40V 0-50A
.....£400
AMPLIFIER RESEARCH Power
Amplifier 1000LAM8.....£POA
MARCONI/IFR 2945/A Radio
Communication Test Sets with options
.....from £3,000
MARCONI 2955/A/B Radio
Communication Test Sets..... from £625
MARCONI/IFR 6200/6200B Microwave
Test Set.....£-
HP33120A Function Generator
100 MicroHZ - 15MHZ Unused Boxed
.....£595
Used, No Moulding, No Handle...£395
ENI 3200L RF Power Amplifier
250KHZ-150MHZ 200W 55Db...£POA
CIRRUS CRL254 Sound Level Meter
with Calibrator.....£95
CEL328 Digital Sound Level Meter with
CEL284/2 Acoustical Calibrator.....

SPECIAL OFFERS

MARCONI 2305 Modulation Meter.£295
MARCONI 6960B Power Meter with
6910 Sensor 10MHZ-20GHZ.....£295
HAMEG 605 Oscilloscope Dual Trace
60MHZ.....£125
BLACK STAR 1325 Counter Timer
1.3GHZ.....£95
HP8484A Power Sensor 0.01-18GHZ
0.3nW-10uW.....£125



ANRITSU 54169A
Scaler Network
Analyser 0.01-
40GHZ £POA

ANRITSU 37247C
Vector Network
Analyser 0.04-
20GHZ £POA

Many Accessories
with each unit

FLUKE SCOPEMETERS 99B Series II
2Ch 100MHZ 5GS/G
..... from £325
97 2Ch 50MHZ 25MS/S..... from £225

STEWART OF READING

17A King Street, Mortimer,
Near Reading RG7 3RS
Telephone: 0118 933 1111
Fax: 0118 933 2375
9am - 5pm Monday - Friday

Used Equipment - **GUARANTEED**
Prices plus Carriage and VAT

Please check availability before
ordering or **CALLING IN**

CAD CONNECTED



PROTEUS DESIGN SUITE VERSION 8

Featuring a brand new application framework, common parts database, live netlist and 3D visualisation, a built in debugging environment and a WYSIWYG Bill of Materials module, Proteus 8 is our most integrated and easy to use design system ever. Other features include:

- Hardware Accelerated Performance.
- Unique Thru-View™ Board Transparency.
- Over 35k Schematic & PCB library parts.
- Integrated Shape Based Auto-router.
- Flexible Design Rule Management.
- Polygonal and Split Power Plane Support.
- Board Autoplacement & Gateswap Optimiser.
- Direct CAD/CAM, ODB++, IDF & PDF Output.
- Integrated 3D Viewer with 3DS and DXF export.
- Mixed Mode SPICE Simulation Engine.
- Co-Simulation of PIC, AVR, 8051 and ARM MCUs.
- Direct Technical Support at no additional cost.

labcenter  www.labcenter.com
Electronics

Labcenter Electronics Ltd. 21 Hardy Grange, Grassington, North Yorks. BD23 5AJ.
Registered in England 4692454 Tel: +44 (0)1756 753440, Email: info@labcenter.com

Visit our website or
phone 01756 753440
for more details