

SCHOOL BUILDINGS IN DEVELOPING COUNTRIES

Background

The building of schools is a significant area of construction activity in many developing countries. School building can be organised as government or donor-supported programmes, or by NGOs and communities, and sometimes by parents themselves. In the former case the programme might comprise hundreds or even thousands of schools, while in the latter case there could be just one school to build, or usually a small number. Local authorities are sometimes also involved in the building of schools, usually in urban areas.

Schools can be considered as primary - catering for pupils up to the age of 10, 11 or 12, or secondary - for pupils within an age range of 10 to 19. Additionally there can be vocational training centres - generally for youths above about 14 years of age and sometimes also for adults, and in some cases schools can also function as community and meeting places, or be used for some form of adult learning, for example in literacy. Some rural schools, to which pupils have to travel considerable distances, can also have dormitories.

As well as the scale of a school construction project and the age range or function to which a school would be put being some significant factors to consider in the design and building of particular school buildings, there are also numerous other important factors including climatic conditions, disaster risk, cultural issues, available building materials and skills, terrain, ICTs and facilities for displays and demonstrations, and health and safety. Because the nature of some of these factors would vary from place to place it is not possible to define an ideal or optimum school building suitable for everywhere. Instead it is proposed in this brief to consider some issues, principles and case studies or examples to act as a guide for the development of a model for a particular location.

A school building can have a significant positive or negative effect towards fostering a productive learning environment. Classrooms that are dark, uncomfortable, crowded, noisy or where the teacher is a long way or at times hidden from the pupils can be a disincentive for pupils to learn or even to wish to continue with their studies. Design of schools from the viewpoint of the user is important to ensure that all or most of their needs are met.

Some Important Issues or Principles

Space - Schools differ from most domestic buildings in that classrooms need to accommodate comfortably as many as 30, and sometimes 40, pupils together with space for a teacher and possibly for storage, displays and equipment. One recommendation is to allow 1.3 m² of space per pupil and an additional two metres between the first row of pupils desks and one of the walls for the teacher's desk, board and space to move. With 30 pupils such a classroom could have dimensions of 7 x 7 metres (or another combination of length and width giving the same overall area), amounting to nearly 50 m² in area. It is in any case not recommended to have a classroom with an area of less than 40 m², unless it is known that there will never be more than 20 pupils in the room.

A basic one or two classroom rural primary school would also require a private room or office for the teacher or teachers and a room for storage of materials and equipment. Rooms of about 10 m² each would accommodate one or two teachers' own area and a room for storage. Additionally, if the school would also be used as a community meeting centre, one

of the classrooms would need to be considerably larger than 40 m², say 80 m² to accommodate about 100 people either standing or seated in rows.

Secondary schools and vocational training centres would generally be considerably larger than primary schools and generally have at least several classrooms. Because pupils would be finishing lessons at more or less the same time, circulation of pupils and teachers would need to be considered. Larger schools can have classrooms positioned around a corridor or courtyard to facilitate circulation. Secondary schools, and larger primary schools, could need additional facilities, including a library, rooms for practical classes and workshops, an assembly hall, a head teacher's office and general office, changing or locker rooms and wardrobes, a sick room and possibly a dining room and dormitory.

A porch or verandah can be a particularly valuable addition to school to provide shading to the classrooms in hot weather and could also form an addition to the teaching, storage, meeting or display space.

Because classrooms and other rooms in schools are generally considerably larger than rooms in houses, this presents more of a challenge in the design and construction of the roof compared with housing. Although the same types of roof can generally be used as for housing, the larger scale and greater complexity of the roofs of school buildings can make the building of a school per unit area considerably greater than for a house. Additionally structural columns within rooms are generally not used in order not to restrict visibility. Roofs for school buildings are considered in more detail in a subsequent section.

Siting - A level site is more suitable than a sloping one as with a sloping site considerably more ground clearance would be required to ensure that the floors of the classrooms are reasonably level. Also the design of the school on sloping ground would also be more complex with possibly the need to connect rooms by ramps or stairs. The site chosen would need to be well drained and not subject to flooding or the risk that debris is brought down into the school grounds after heavy rains. Tall trees can provide useful shading in hot weather, but if the area is at risk from very high winds and storms then it would be better to site the school away from trees which can fall or shed branches. For young children a busy main road nearby can be a hazard, as can a river, pond or well. A fence around the school grounds can be useful to keep animals out or to discourage young children from wandering off.

Cost - Reducing costs can be a high priority in building schools as, if this is a community project, community members who might be relatively poor, would want to keep the contributions they make to building the school to a level they can afford, and in government or donor funded programmes reducing the cost per school can enable more schools to be built. However, it is important to take into consideration not just the cost of building the school itself, but also the cost of maintaining it over its entire period of use. A cheaply built school could turn out to be a false bargain if subsequently there are defects to be put right, materials and components need to be replaced after a relatively short time, and there is a continuous need to undertake repairs and rehabilitation. A school should also not be built so cheaply that it produces discomfort for the users, for example with too few openings or windows that the rooms are too dark, or built with very light materials that heat up quickly in the hot weather and make it uncomfortably hot in the classrooms, or with a flimsy roof that lets in water when it rains.

Community Participation - Engaging local people, especially parents, in dialogue about the layout and facilities at the proposed school is important for the school to meet the needs of the local community and be looked after and cared for. In some cases local people might also be interested to contribute towards the cost of additional facilities if these were to be provided. For practical and cost reasons it might not always be possible to build and equip a school in exactly the way local people would like, in which case a compromise would need to be reached, but at least it is important to discuss the school with local people. One decision to consider is whether the school will only be used for the education of children or whether there would also be facilities for the community to meet and, possibly, also a resource centre

for facilitating local development needs. Local people can also offer more practical help such as undertaking of some of the building work. However, if they agree to do this, such help has not to be taken for granted and some form of modest payment or the offer of some additional facilities for the school might need to be provided. When the school building is completed the occasion can be marked by some sort of cultural event to which all local people are invited. If the school is then handed over to the local community some arrangements would need to have been made for upkeep and maintenance. Even if the school building is the responsibility of an NGO, local authority or government education department, the local community can still make some contribution towards the running and upkeep of the school.

Lighting - Many rural schools rely on natural lighting for illumination in the classrooms as the schools are either not connected to electricity supplies, or the use of electricity for lighting is expensive and this would significantly add to the cost of running the schools. Glass is sometimes used in the windows, but this adds a considerable expense and if the hot sun shines directly through the glass this can make the classrooms very hot. With windows that can be swung open to let in ventilation, this can present an accident risk to young children, and safer options for windows that can be opened fully are more expensive. A cheaper option is to use no glass but to have wooden or metal shutters that are closed when the school is empty or when it is raining heavily. If the shutters are closed due to rain then it would be too dark to read or write in the class, so either artificial lighting would need to be provided, or the school closed for the day when a storm is due. In India and some other countries brick jallis have been used to create opening to let in light and ventilation in the wall. Because the opening between the bricks are relatively small in size they would be effective for excluding water from rain except when it is very heavy and driven onto the wall by a strong wind.

Recommended minimum illumination levels in schools are 130 lux in general classrooms and offices, 200 lux in laboratories and 300 lux in areas used for drawing, crafts and sewing. While it would rarely be possible to have access to a light meter to check on these light levels it can be assumed that in a normal sized classroom it would need at least two, and preferably three, window openings of at least 1500 x 1200 mm, or openings of other sizes with equivalent area, to achieve the 130 lux level in tropical areas for sunny or lightly overcast conditions. It is better, for more even illumination, for the classroom to have two or more external walls each with a window, rather than having all the windows in one of the walls. Long narrow rooms with openings at only one end, which in any case are less practicable as functioning classrooms, would need a greater area of openings than suggested above as light levels would fall off noticeably at the far end of the room. Jalis, such as that shown above would need about 1½ more area of openings in total than for conventional windows as a part of the opening in a jali is effectively cut off from admitting light. It is preferable to arrange the classroom to avoid the teacher or pupils having to face the sun directly, or reflected and causing glare from some surfaces such as boards.

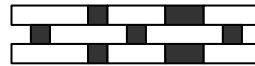

Figure 1: View of part of brick jali, with the black shading representing the openings

Services and Infrastructure - When funds for school building are very limited there can be an inclination not to provide a dedicated water supply and sanitation services, but such provision is very important and could only be omitted in exceptional circumstances, e.g. if it intended to provided services at a later, but not very far-off, date. Nevertheless there are still numerous schools throughout the world, generally very small schools in rural areas, without dedicated water and sanitation provision. If public water supplies and latrines are located close to a school then this situation is acceptable. If not, then high priority needs to be given to installing these facilities within the school grounds or close by.

If water reticulation is available then this would need to be extended to the school and a water tap provided. If this is not available nearby then consideration would need to be given to sinking a well or, preferably, a borehole at or near the school. A well is sometimes preferred for water supply in remote rural areas because it can be dug out by hand, whereas a borehole needs to be drilled out mechanically and an engineer with a drill would need to be hired for this. However, if a well is used it would still be preferable to have the top covered and a suitable manual pump inserted, rather than having an open well and using some form of winch and bucket, where there is a risk that, particularly, young children can fall in. Shallow wells or ponds would rarely be suitable as they would be likely to become dry when there is no rain, and the water can more easily become contaminated by human and animal wastes.

Advantage can also be taken of the greater roof area of school buildings compared with domestic buildings, but only if the roof is sloping, to collect rainwater. Guttering and a rainwater collection tank would not add greatly to the cost of a school but would provide the significant benefit of allowing the demand for water from school pupils to be partially met. The collected water from the tank would be suitable for washing, but a simple sand filter would need to be used if the water would also be used for drinking. For further information on collecting water from roof run-offs see the Well Fact sheet on Domestic Rainwater Harvesting - <http://www.lboro.ac.uk/orgs/well/resources/fact-sheets/fact-sheets-pdf/drh.pdf> although dealing with domestic situations, they could also be applied to schools.

Safe access to a latrine or, more likely in urban areas, a flush toilet, is essential for a school to function effectively. If children are unable to relieve themselves during school time they would be likely to be poorer learners, and if they do so behind vegetation, they would be more likely to be attacked by insects and animals, or be at risk of getting diseases and infections. Girls, whose education is in any case often curtailed in favour of boys, would be particularly disadvantaged if no latrines or toilets were available, as they would prefer to be better concealed than boys when relieving themselves so that they would go further away putting themselves at greater risk or be prepared to put up with greater discomfort than boys to the disadvantage of their education.

To avoid unpleasant smells it would probably be best to site a latrine at least 30 metres away from the school building, and downwind of the prevailing wind. The latrine needs to be properly constructed and a proven design such as the Ventilated Improved Pit Latrine (VIP) developed by the Blair Research Institute in Zimbabwe used to avoid smells and diseases, and flies and other insects getting into the latrine. If there is rock below ground, or if there is a high water table the traditional latrine pit - which goes down several metres into the ground, might not be suitable, so the latrine would need to be built above ground, for example as a concrete box type chamber. This option could, however, be more costly than the conventional below ground latrine.

Further information on water and sanitation for schools and in general can be found at:- <http://www.lboro.ac.uk/well/resources/fact-sheets/fact-sheets-pdf/ssahe.pdf> - for the WELL Fact Sheet on School Sanitation and Hygiene Education; and technical briefs produced by WELL on specific topics at, <http://www.lboro.ac.uk/well/resources/technical-briefs/technical-briefs.htm>

An electricity supply for schools is becoming increasingly important, especially for secondary schools, even in rural areas, with the increasing use of computers and audio-visual media in schools. A separate dedicated power supply from an oil-fired generator would usually be an expensive option, so an important consideration in the siting of a secondary or even a large primary school would be on whether it can be connected easily to the electricity grid. If this is not possible and a generator too expensive, some other options could be possible, but each one by themselves would be unlikely to meet all the electricity requirements for a school. These options would include the use of solar power for computers and radios, the *solar lantern* (<http://itcltd.com/glowstar/>) for lighting, paraffin or kerosene lamps for lighting - although increasing risk of fire and possibly poisoning, and use of biogas for lighting, although again not an especially safe option.

Except for cases where the school serves a very localised area and children can go home for meals, it is likely that a meal would need to be provided at some time during the school day. In small schools, this could be done simply under some form of gazebo structure where the cooking would be done. The open sides of this structure would allow the smoke from cooking to escape. If cooking is carried out indoors it would be important to ensure that an adequate flue is installed and maintained to allow smoke to be removed. Larger schools and colleges would need a dedicated institutional kitchen to be included in the school design. Another Technical Brief from Practical Action provides further details on stoves for institutional and commercial kitchens.

In high mountain areas or in developing regions in the far North or South, space heating would be a necessity for all or part of the year. For this purpose various types of stoves to burn oil or wood / biomass are available on the market. However, in cold climates the availability of wood or other biomass for fuel could be very limited. Larger buildings would need a dedicated oil, coal, wood or biomass or waste briquette fired boiler and a hot water distribution system to heat radiators.

Building Materials - A wide range of building material options can be used for low cost school construction. The main factor in the choice would depend on what is locally available or produced in the area and the relative cost of the materials available locally. Cost and availability of materials varies from place to place, so what is cheap and available in one area might not be so in another. Climate is another important factor determining material choice and building design. Whereas, for example, the use of earthen-based flat roofs as well as earth-based arches, vaults and domes would be completely suitable for relatively dry climates, these constructions would be less suitable in wetter climates unless they would be built and finished by highly skilled labour. It also needs to be noted that in areas with night frosts, or with very high daytime temperatures, a more massive type of construction would be better for reducing the effect of temperature change as a more heavy building heats up and cools down slower than a light one. This would imply the use of more massive materials such as rammed earth, stabilised earth blocks, or ashlar stone or rubble for walls and clay or concrete tiles or thatch for roofs, rather than a lightweight walling materials such as ferrocement or timber panels, or galvanised corrugated iron sheets for roofs.

Although researchers and designers have sometimes devised innovative designs and use of materials for building, generally to reduce costs, make more use of waste materials, or to make more efficient use of space, there would also be greater risks with aiming to use particularly innovative or experimental materials and techniques. It would generally usually be better to choose materials which have already been well proven, and particularly if they are also well known about and used in the local area. Some relatively common materials used for construction are described briefly below, though they would not all be suitable for use in every case.

Walls

- Stone - rough hewn (rubble) or worked smooth (ashlar) blocks; the former being cheaper to produce while much less mortar is needed with the latter if they are well-finished
- Stabilised soil blocks - now a proven low cost technology, especially in areas where soil of low shrinkage - which requires less use of costly stabiliser, is available locally
- Rammed earth or pisé - a low cost material, though stabiliser might need to be added to control cracking, but labour-intensive and heavy to work with. The earth wall is built up between shutters or formwork that are progressively moved up the wall as construction proceeds. Use of internal and external plastering preferred with rammed earth buildings to reduce the need for maintenance, which is otherwise high, and the harbouring of insects and other pests.
- Fired clay bricks - requires a higher level of skill for laying than the larger blocks, also in some cases field bricks might be warped and of variable size, so relatively large quantities of mortar are required
- Concrete blocks - usually hollow rather than completely solid blocks are used as this allows some saving on the material for the blockmaker with the same level of structural stability as solid blocks. Blocks can be used structural or loadbearing, or used for infill.

The strength and durability requirements of blocks for structural use need to be considerably higher than those for infill

- Precast concrete panels - panels are inserted within a structural frame and bolted with each other and the frame. Panels contain steel reinforcement, which increases the cost. However costs can be reduced by mass fabrication, so the application of pre-fabrication would be likely to be most relevant to very large building programmes with many identical or modular constructions. Prefabricated components do not require high levels of skill to erect, and erection can be relatively fast so having a low labour requirement - rarely a priority in many developing countries.
- Ferrocement - generally made by covering a steel wire-based mesh or framework on either side with cement mortar. Costs are saved by using chicken wire rather than more conventional steel reinforcement, and the walls of low rise buildings can be quite thin - only a few centimetres across. Ferrocement buildings also require labour-intensive construction, and the construction techniques are not difficult to learn. However, many do not like the appearance of ferrocement buildings and they certainly look quite different from conventional constructions. They also heat up and cool down quickly with changing temperature, and there are some doubts about their long-term durability in places where severe climate can be experienced.
- Timber and bamboo - can be used where this is plentiful supply. Strong bamboo species are a particularly versatile low cost construction material. However, bamboo and many timber species decay relatively quickly in the climates where they are found unless they are treated with preservatives, and there are no completely safe preservatives, though some are less hazardous than others. Also, some preservatives have limited effect on termites and other wood-boring insects, against which special and more costly precautions need to be taken.

Roofs

Note that the options for good roof construction materials are generally more limited than for wall construction materials, and the materials that offer better performance are generally higher in cost.

- Grass, reed or palm leaf thatch - a low cost option in rural areas, though it needs to be noted that good thatching material is getting in short supply in some places. However, despite its low cost thatch is generally an inferior roofing material as it can harbour insects and other pests, can be a fire risk, needs to be made up skilfully to offer reasonable performance, and deteriorates rapidly in a tropical climate due to the effects of weather and insect attack. If the roof needs to be renewed every few years than a thatch can prove to be a false economy, despite its low initial cost, compared to other roofing materials. A reasonable ceiling below the thatch roof can significantly improve safety and the learning environment, but would add to the cost.
- Galvanised corrugated iron - this is widely used as a low cost roofing material in developing countries, particularly in Africa. However, this material has a number of limitations including that in humid conditions it corrodes and might have a lifetime of only 5 - 10 years. Also, it has rapid heat gain, so the indoor space underneath can become uncomfortably hot quite quickly during the day, and heavy rain on the roof is very noisy, making it difficult for children to hear each other and the teacher. With the thickest gauge of sheets, or ones that are specially coated, these problems would not be so great but their costs would be very much greater than for the standard sheets. Again a ceiling would produce significant improvements, especially in giving better acoustics.
- Asbestos cement - the use of corrugated asbestos cement sheets in buildings has been banned in most Western countries, due to the lung cancer risk from asbestos, but these sheets continue to be produced and used for building in some developing countries. Although the risk from asbestos cement is primarily to fabricators and builders using this material, rather than building users, as children's health is involved it is strongly advised not to use asbestos cements boards and sheets in school buildings. In some Western countries safer alternative cement-based boards and sheets are produced, generally based on using cellulose fibre for reinforcement. However, it is not known whether any of these materials are yet produced in developing countries.
- Micro concrete roofing (MCR) tiles - MCR technology is now well-established in a number of countries and small complete production plants can be bought for as little as

£1000, so for a programme building a number of schools in an area it could be practicable to obtain such a plant to produce tiles for all the schools. MCR tiles and semi-sheets are relatively durable if well made and offer some protection from thermal gain and the noise of heavy rain or hail falling on the roof. Compared with some other materials such as galvanised corrugated iron the roof is heavier, so a more complicated and expensive roof structure is required, and the installation of the tiles is more complicated so a level of skill is required. These additional costs, however, can be offset against the greater durability of MCR tiles.

- Fired clay tiles - the use of these tiles is now somewhat limited and generally confined to areas where they are produced. Whereas a number of types of clay can be used for fired clay bricks, only a relatively few clay deposits have the necessary characteristics for the production of satisfactory fired tiles, so the availability of these tiles is by no means widespread. A number of shapes of clay tile have been produced. One of the most common is the rounded Bangalore type. Generally roofs of fired clay tiles are even heavier than for MCR, so there is the added cost of the roof structure to consider. Also, as clay tiles require a high-energy input to fire them they are not particularly environmentally benign, nor low in cost. Their main advantage, if well produced and properly installed on the roof is their high level of durability. A roof with these tiles would be good for 20, if not 50, years before the tiles need to be substantially replaced.
- Domes, vaults and corbelling of fired clay bricks or stabilised soil blocks - the use of these techniques offers the advantage that a roof structure is not required. However, the roof themselves would be heavy, so it would be important to ensure that the walls are strong enough to support these roof and additional strengthening, e.g. the use of a structural frame in the wall, might be required. The use of these techniques has most potential in areas where there is a tradition of building of domes, vaults and the use of corbelling. In other areas masons might be reluctant to use them and could need a lengthy period of trials and familiarisation. The use of domes, vaults and corbelling is generally best suited to relatively dry climates without significant night frosts, unless a protective external coating of render is applied, as the mortar joints between the bricks or blocks would be particularly exposed to rain and at risk of being damaged over the long term. Nevertheless these types of roofs are generally quite durable and domes have been found to be particularly effective against small to moderate earthquakes provided that they have been bonded well to the walls and the walls themselves have been strengthened so that they have not been bowed and crushed by the movement of the heavy dome during the quake.
- Earth or lime plaster-based flat roof - in some very dry areas there is a tradition of building flat roofs. The earth or plaster of the roof is supported on timber, or sometimes in newer buildings reinforced concrete, joists, which in turn support some form of reed or wire matting on which the earth or lime-based plaster is placed. However, even in relatively dry areas there can be heavy rain occasionally and after such spells the roofs would be likely to need extensive repair.

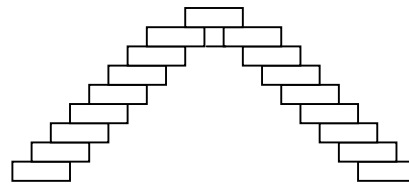
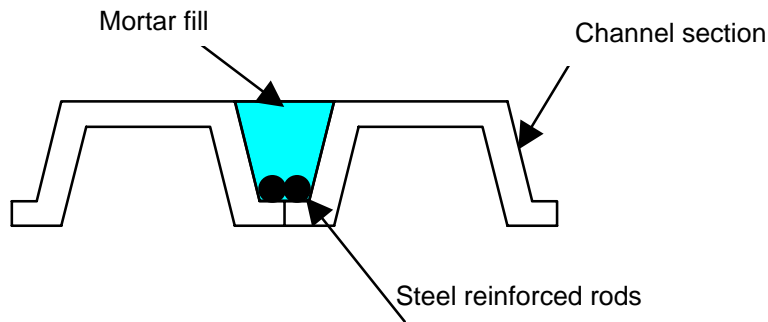

Figure 2: Corbelling

Precast concrete or ferrocement panels or channels - which are made sufficiently long to span the width of a roof section, for a small building, or to span between dividing walls or supporting beams for larger buildings. For precast concrete sections the cost of moulds, which need to be quite thick and heavy and accurately made, is a significant element of the total cost of the component. Ferrocement components are fabricated on formers of brick, concrete or hardwood, which are cheaper than fully made up concrete moulds. However, the making of ferrocement components in this way is much more labour intensive than the moulding of more conventional steel re-inforced panels or channels. Note also that use of precast components implies a high level of standardisation of components and relatively large-scale production, so would be most suitable for quite large-scale school building programmes, for which they would also offer some cost advantage compared with some

other types of roofing options. The weak point of panel or channel construction is the mortar joint that would need to be put in between individual elements. This needs to be made to a good standards if it is not to crack and let in water. This type of construction is not really suitable in very wet areas as it would only be a matter of time before the mortar joints begin to leak, and putting a mastic or sealant material would be more expensive and not give much improvement as unless a very expensive option is chosen, this would deteriorate in high heat and exposure to sunlight. An example of the use of channel sections is shown below.

Figure 3 Precast reinforced concrete channels



Other examples can be found in Bonner & Das (1996)

Maintenance - Undertaking a maintenance schedule is important for the school to remain a safe, healthy and comfortable place for learning. As noted above, some types of materials and construction details are more durable than others, however, all schools would require maintenance and inspection regularly. With any type of school building the fabric needs to be checked over thoroughly at least once a year, or after a serious wind or rain event. Small defects which are noticed, e.g. small cracks in plaster, missing tiles, small holes in walls or floors, or peeling of paint, would need to be repaired as soon as possible to avoid them getting worse. More serious defects, e.g. large cracks in walls, especially around openings, the falling down of significant sections of plaster or ceiling, roofs which leak regularly, doors, windows or shutters which can no longer be closed properly, and infestation of pests, could need a more thorough investigation by an expert and, possibly, quite extensive remedial action. It is useful to keep a written record of the inspections and maintenance that were carried out, what defects were found and what action was taken on them. If repairs are needed, a procedure also needs to be in place for paying the cost of the repairs, whether this is charged to a government department, local authority, NGO or to the parents themselves.

The Construction Process

With a relatively small school based on one, two or a small number of classrooms, the scale of construction and skill requirements are not greatly different from house construction - except for the case, already noted, that classrooms are generally significantly larger than domestic rooms. A local small building contractor, who can also be assisted to a large extent by local people, can then build the school. In some cases schools have been built entirely by local communities, sometimes assisted by an NGO or government agency.

Plans would need to be prepared for even a one-roomed school. This would need to be done by an architect, draughtsperson or someone who has already been involved in a school building project. However, if plans from another school building project are available, from, for example, an NGO or a government department, it might be possible to use these, if they are considered suitable, and this saves on the cost and time needed to prepare plans.

Once the plans have been prepared the quantities of materials and amount of labour required would need to be estimated, and the costs calculated. It would also be useful to prepare a schedule of construction activities and an estimate of how long each activity would take. Someone who has been involved with a school building project before could most usefully prepare these estimates. During construction ordering and use of materials,

spending and progress on building can be monitored against the estimates to assess whether the project is ahead of, within or behind target. If problems occur, e.g. the project is costing more than expected, more materials are being used than expected or it is taking much longer than planned, an investigation would need to be carried out into why these problems are occurring and what can be done to remedy them.

Ground Preparation

Once the site of the school has been chosen the boundaries of the outer walls of the school would need to be marked out on the ground, according to the plan, and the area within the boundaries cleared of topsoil and, levelled or, on sloping ground, terraced. Surveying tools would need to be used to ensure that the site is level and that the angles between the walls are the ones required, especially if the shape of the building is more complex and does not use only right angles, though experienced builders might be able to lay out simple building by eye and hand. Once the ground has been cleared and levelled, intermediate walls between the classrooms and other rooms can also be marked out on the site.

Foundations and Floors

Unless raft or slab foundations - which are generally quite expensive options and not usually used for low cost buildings, are used, foundations would need to be provided underneath all structural walls. Note, however, that raft or piled foundations would be likely to be needed if building on expansive soils such as black cotton soil to avoid excessive settlement of the foundations. Structural walls are those which support substantially the load of upper storeys, roof, or other imposed loads on a building. For simple, small, rectangular buildings they are generally the external walls, though for larger and more complex buildings this would also include some of the internal walls, which together with the external walls would form the shell or structural form of the building.

Rectangular ditches for the foundations are dug to a depth until solid rock or soil with a good bearing capacity is reached. For one to three storey buildings foundation depths are typically 0.8 to 1.2 metres. Exceptionally, if beyond this depth the ground is still not providing a firm base, the ditch can be dug deeper then backfilled with brick and stone rubble before leveling. Note, however, that in cold climates the top of the footing of the foundation needs to lie below the frost line. If ground frost of below - 15°C might be expected the depth of the ditch would need to be greater than 1.2 metres, rising to 1.6 metres for ground frost of - 30°C.

The footing of the foundation is usually made of a relatively rich concrete mix, for example of one part cement to three of sand to six of river or lake bed gravel or crushed rock, which needs to be well-compacted. The width of the footing would be determined by local ground conditions, so the dimensions for other well-constructed buildings in the area would be a useful guide. Conventionally 45 or 60 cms are used for relatively small buildings. The height or thickness of the footing can be taken as the same as the width of the foundation wall above the footing. The foundation wall needs to be as wide or slightly wider than the wall above. It is unlikely that foundation wall widths below 20 cms could be considered completely safe, and even for relatively simple buildings widths as high as 40 or even 45 cms have sometimes been used. Again, experience from other buildings in the area would be a useful guide.

The foundation wall needs to be built with a relatively strong, durable and water-resistant material. These materials would include most hard ashlar or rubble stone (most soft stone as well as some types of limestone might not be durable or strong enough), most stronger types of fired clay bricks - generally not field fired bricks, dense concrete blocks or bricks, or cast concrete. If stabilised soil blocks are used these need to be made with a low-shrinkage soil, such as laterite, with extra stabiliser and waterproofer and preferably made in a machine press that can apply higher pressures than manual presses. It is normal practice for the foundation wall to be built to protrude above the ditch that was built for it to at least the level of the internal floor. It is also advisable, unless in very dry climates where the water table is

always far below the footing, to cap the foundation wall with a damp proof course. This can simply be a rich concrete mixed with a waterproofing compound.

The floor is made by partly filling the space between the foundation walls with pebbles, broken brick, coarse sand, or even broken bottles provided that the glass does not protrude from the floor. This then needs to be leveled. This is covered by a layer of concrete, stabilised soil, or concrete or clay tiles. Timber floors are often used in Western countries, but this is generally quite an expensive option and liable to be attacked by termites where they occur.

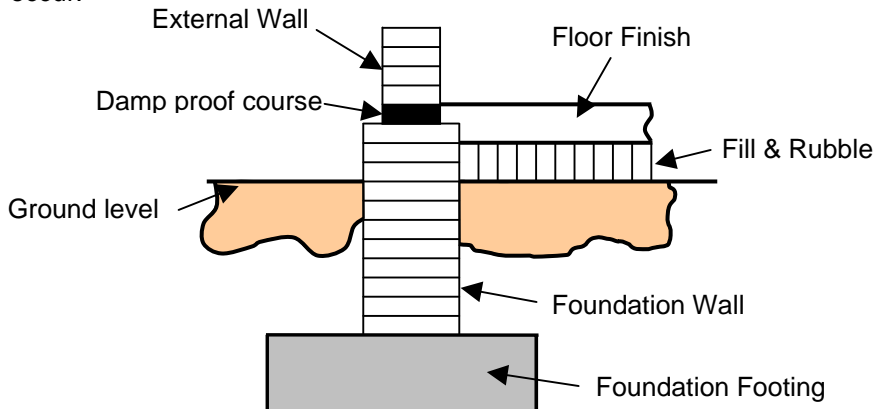

Figure 4: Construction of the floor

The above example of a foundation wall is the most common type of foundation, but other types of foundation, e.g. arches, are also possible. Special care needs to be taken on sloping ground to ensure that the trench for the foundation is level. If the slope is steep the trench might need to be dug as a series of steps with the footing covering more than one of the steps.

Walls

Some of the materials and types of construction used for walls have been discussed previously. For low-rise buildings the simple masonry wall is by far the most common type of construction. The use of a structural frame with precast infill panels is unlikely to offer any advantage unless a very large school building programme is envisaged with the components manufactured at a central facility. A variety of types of bond is possible for erecting the bricks or blocks. One particular type is the rat-trap bond, originally developed in India and being more economical in the use of bricks and blocks and mortar than most other types of bond. Drawings of the rat-trap bond and other economical types of brick and block bonding construction can be found on: -

<http://www.saud.ku.edu/ngore/nilsweb/cinvablocks/kucinva/strength2.html>

or

http://www.archifacts.co.uk/html/brickwork_paving_bond_patterns1a.htm

Masonry materials are bonded by a cement-based or lime-based mortar. For the wall to function properly as a structural element it is important that the mortar is not significantly stronger or harder than the material which it bonds and it can even be significantly weaker. A mortar based only on cement and sand can also be troublesome for letting water into the wall and for causing spalling (the breaking off pieces from the surface) of the bricks or blocks. However, a mortar based only on lime needs to be applied with quite a high level of skill for good effect, takes a long time to harden and is best applied in a very thin layer. To overcome these disadvantages of both lime and cement it is common practice to mix lime and cement for a mortar, for example in proportions of one part lime to one of cement to six of sand, or one part cement to two of lime to nine of sand. If a low strength mortar is required, for example if using relatively low strength stabilised soil blocks, soft stone or field fired bricks it can be made from one part lime to two parts pozzolana, such as some types of volcanic ash and ground up fired clay, to nine parts sand. As the mortar material is usually

more expensive than the bricks or blocks it is used to bond it is good practice to make the mortar joints as thin as possible, and to only mix sufficient material that can be used within about half an hour, or somewhat longer if using pozzolanic cement.

One of the most difficult aspects of masonry construction is the making of openings for doors and windows. It is important to plan in advance of the construction where these openings would be situated and what their size would be. Before building the wall wooden pieces can be cut out and set up to show where the door would be. The same would need to be done for window openings once the wall has been up to the course adjacent to the bottom of the opening. It might sometimes be necessary to cut or break bricks or blocks to fit in the door or window openings, but with planning the positions carefully this can be minimised. It is necessary to cover the top of the opening with a rectangular lintel, arch or corbelling, as mortar joints are extremely weak under bending stress and would give way easily when subject to this stress, as occurs at top of an opening. Steel reinforced concrete is the material normally used to make the rectangular lintel.

Walls are built up to a height of 2.6 to 3 metres above the floor level for each storey. Local building practice or building codes, if available, would determine the height for the top of the wall. It would not be advisable to choose a height below 2.5 metres, even though well above almost everyone's head height, as some people would feel uncomfortable with a low ceiling. A height close to 3 metres would need to be used if electric lights are to hang in the room. The exact height would also be determined by the dimensions of bricks and blocks used in the construction.

In areas where there is a risk of earthquakes special measures for the walls would be needed to increase safety. These would include a ring beam - a beam the sections of which are joined together and extending continuously over the top of the external walls, and bracing or a framework structure within the walls. The elements of the ring beam, bracing or structural framework would need to be made of a tough and flexible material such as timber or reinforced concrete with adequate steel reinforcement.

Where there could be a termite problem a termite barrier would need to be inserted near the bottom of the wall. One possible option is shown below. This is of concrete and would need to be well-made to ensure that there are no cracks in it which termites can penetrate and enlarge.

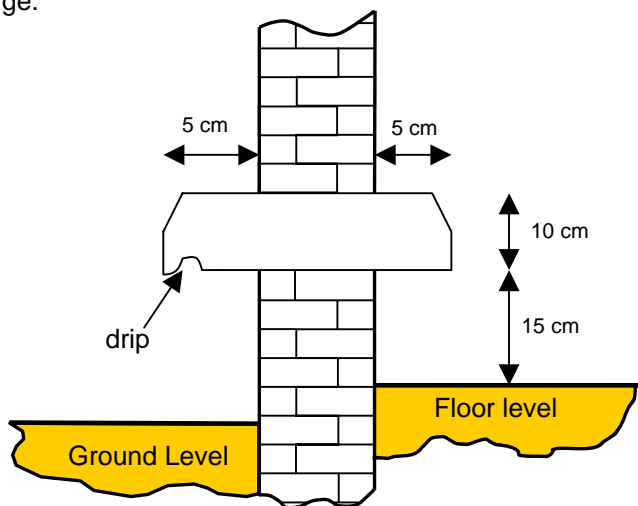

Figure 5: Termite barrier

An external plaster or render would help to protect the building fabric from weather damage, improve appearance and fill in any holes which could harbour insects and dirt. As with the mortar it is important that the plaster is no stronger or harder than the material to which it is bonded, particularly for relatively weak and friable materials such as earth or soft stone. A plaster made only with Ordinary Portland Cement as the binder would be too hard for most materials, and there is the risk that water penetrates behind it causing the plaster to fall off

and sometimes taking pieces of the material to which it is bonded with it. Use of a lime and cement mixture, lime only, or lime-pozzolana for the binder would almost always be preferable to just using cement. Typical mix proportions of plaster mixes are one part lime to two of sand, one part lime to two of pozzolana (such as some types of volcanic ash or finely ground burnt clay) to nine of sand, or one part cement to two of lime to nine of sand. Plaster needs to be well-bonded in to the surface to which it is fixed, so a good key needs to be provided. This can be done by removing some of the mortar from the joints to create grooves (raking), making grooves in the surface or fixing a wire frame tightly to the wall. Plaster is applied in two, but preferably thin three layers. The layers or coats would preferably be less than one centimetre thick each, but certainly so for the final or finishing coat which needs to be the thinnest.

The first coat is applied, scratched to create a key for the second, then allowed to harden for several days before the second is applied. Keeping a cement-based coat moist would help it to harden, while with a lime-based coat allowing the drying to take place only very slowly would help to reduce cracking. The procedure is repeated for the second coat if a third coat is to be added. The finishing coat is made with a richer mixture (containing more binder), and a fine sand so that it can produce a surface of smooth appearance.

Walls can also be plastered or painted internally. A white gypsum or lime-based surface makes a room seem lighter, can help to improve acoustics and creates a smooth surface where insects and dirt have difficulty accumulating. Gypsum is a particularly useful plastering material, but is not recommended for external use, except in dry climates, as it is damaged by water. Note that if walls are to be left unplastered it is important to point the mortar joints for neater appearance and to reduce weather damage. Even if it is decided not to plaster a wall, a thin layer of limewash applied every year can help to reduce rain damage and improves the appearance.

Roofs

Pitched and flat roofs are the two most common roofing types, though as discussed previously other types, e.g. vaults, domes and corbelling, are also possible. Flat roofs of low cost materials such as compacted earth or a lime based mortar are generally only used in dry climates as in wetter areas they would be easily damaged by rain and let in water. Flat roofs have been used in the some temperate countries where the climate is wetter, typically made of timber decking covered by bitumen felt sheets, but this is a more expensive option, and no guarantee that the roof would not leak. Bitumen-based sheets would also be likely to soften and deteriorate significantly in the hot sun in tropical countries, so the use of expensive additives in the formulation might be needed to reduce this.

Note the two most common types of roof construction of pitched roofs - the gable roof and the hipped roof

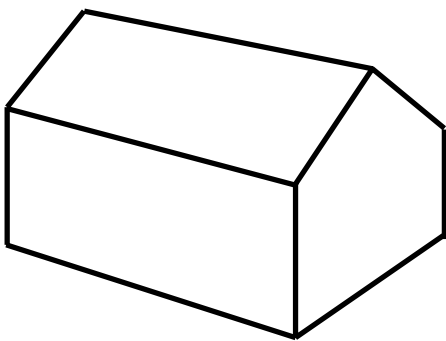

Figure 6: Gable Roof

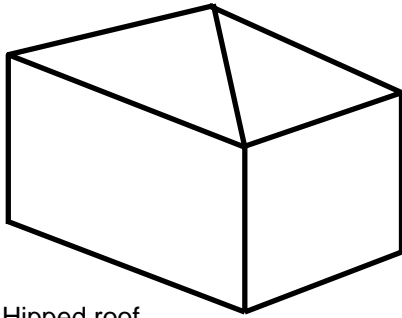

Figure 7: Hipped roof

There is no particular advantage of one of these roof types over the other, though despite the more complicated wall construction detail required for the gable roof the overall construction of a building with this type of roof would be less complicated than for one with a hipped roof, where trusses of different sizes would be required and these would need to be positioned quite accurately.

The simplest roof is the shed roof, but this is generally restricted to small one storey buildings less than about 4 metres across, otherwise the economy gained in the construction of the roof is lost in having to build one of the walls considerably higher than the other to give the roof sufficient slope. Most schools are usually not as small as this.

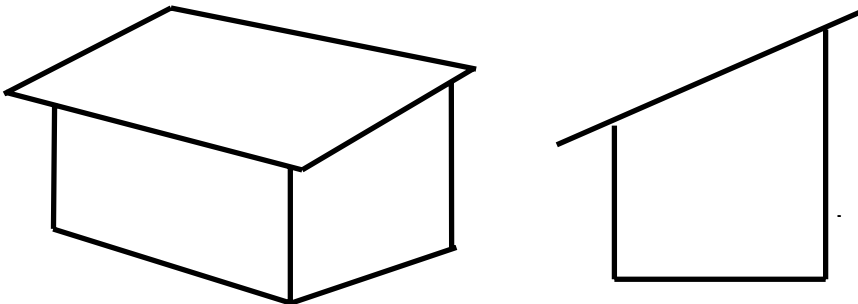

Figure 8: Shed roof

An important feature on the top of the wall is the wall plate, used for fixing the roof trusses of a pitched roof to the top of the wall. This is usually of wood. There are a number of ways of fixing the wall plate to the wall including drilling or forming holes for bolts in the wall, into which the bolt is inserted, then pouring a slurry of cement mortar around it, with holes drilled in the wall plate to match position of the bolts in the wall. Another way is to insert steel rods horizontally into the wall 0.5 to 1 metre below the top of the wall. As the wall is being constructed steel straps are tied to the rods, looped round the wall plate and tied back to the rod. The cost of inserting the wall plate can be reduced by instead of having bolts or straps in the wall about every metre, to put these in about once every two metres, but then also to embed the wall plate in a good cement mortar at the top of the wall.

For small low cost buildings in areas without earthquake risk and on flat ground a wall plate is recommended but not essential if flat roofs are used. Beams are laid across the walls then purlins laid at right angles across the beams and tied to them. Then a woven reed mat, thin timber battens or wire mesh fixed to the top of the purlins. Finally a lime-based concrete or stabilised earth covering is laid in several layers over the top, finished with a thin cement or lime-based screed containing a higher proportion of cement, or an bitumen-based compound to reduce water leakage. The massive construction of such a roof makes it very unlikely that it would move about significantly if no wall plate is used.

For pitched roofs a roof structure needs to be put in place to take the roof covering. Normally this consists of triangular roof trusses placed across the walls, and purlins across the trusses to which the roofing sheets or tiles are nailed or tied. The trusses and purlins are usually of timber, but can also be of steel or reinforced concrete. A simple type of truss suitable for relatively small buildings is shown below

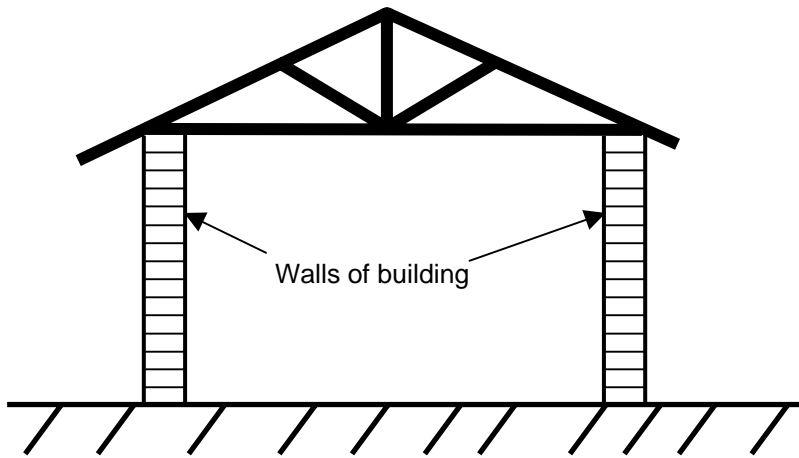

Figure 9: Triangular roof trusses

Other types of trusses are used for larger spans, and for details on these the reader is referred to

Note also an alternative arrangement for a shed type building - in this case the slope of the roof is taken by the truss, so all the walls can then be of the same height.

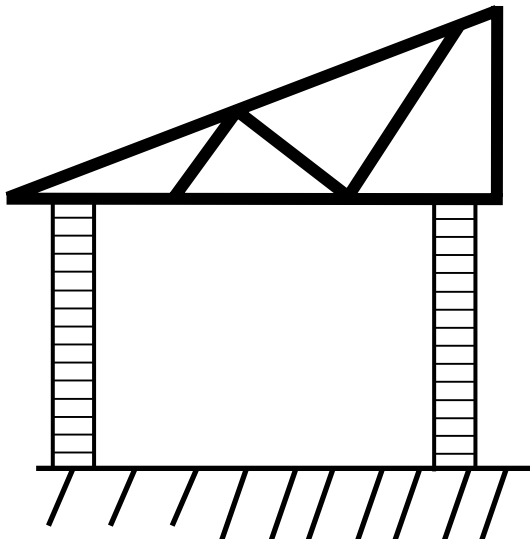

Figure: An alternative arrangement for a shed roof

The type of trusses to use, their spacing, the size of their members and the size and spacing of the purlins depends on a number of factors including the type and strength of material used to make them, the type of roof (gable, hipped, shed or other), the size and shape of the building, the weight of the roof covering and the sizes of the tiles or sheets used, and other imposed loads on the roof, e.g. from wind or snow. In some cases standard roof designs can be used, or guidelines exist from local or national building standards. However, where these are not appropriate the design of the roof structure would need to be determined. Details on roof structure design are too lengthy to be given here, but can be found in The

Roof Structure Guide, and The Roof Truss Guide, both produced by SKAT, further details on which can be found in the Reference section.

The internal angle of a typical roof truss is taken as 30°. Although for small buildings angles as high as 45° have been used, this is not recommended for school buildings where the truss would be likely to need to have a greater span than for some other types of building such as houses. It is also generally not recommended to have an internal angle of the truss of less than 25°, or water runoff might cause seepage of water underneath the roof covering.

Roof trusses are assembled on the ground according to prepared or available design drawings then lifted into place at the appropriate position on the roof. They are fixed to the wall plate with bolts or steel straps. Until the permanent purlins have been put in place the trusses would need to be kept stable by connecting them together with temporary purlins or ties. When the trusses are all in place the purlins are then laid across them and nailed or tied in place.

The roof covering (usually sheets or tiles) is laid over the purlins, starting from the bottom of the roof. The sheets or tiles are nailed or tied to the purlins. A special type of tile, known as a ridge tile is needed to cover the top of the roof. Fixing this in place can be slightly more complicated than for laying the rest of the tiles or sheets. With corrugated iron sheets making the ridge or crown is relatively straightforward, as this just consists of a flat steel plate bent at an angle the same as the top of the roof, then nailed to the tops of the sheets and the purlin below.

For information on vaulted, domed or corbelled roofs the reader is referred to Bonner & Das (1996) and Joffroy & Guillaud (1994) - further details in the Reference section below

Information Sources

1. Bonner, Roger R.M. & Das P.K., *Vidyalayam, Cost Effective Technologies for Primary School Construction*, Overseas Development Administration, New Delhi, 1996 (Department for International Development, British Development Cooperation Office, 50 M Shantipath, Chanakyapuri, New Delhi - 110 021, India)

A very useful and practical guide on school building with some emphasis on innovative technology and practice to reduce costs, especially of roofs. This includes use of arches, corbelling and precast elements. Although some of the technologies presented have been little used outside India, others have more widespread application. Main headings cover *Understanding Cost Effective Technologies, Foundations, Walls, Opening Supports, Roofs, Non-structural Items, Methodology for Ranking and Selecting Cost Effective Technologies, and Contact Organizations and Bibliography*.

2. Stern, Peter (Ed.), from an original work by F. Longland, *Field Engineering, An introduction to development*, Intermediate Technology Publications Ltd., London, 1983, ISBN 0 903031 68 X
A useful practical text on general civil engineering and building covering surveying tools and methods, site leveling and earthworks, earth as a building material, making and building with bricks, stone, lime mortars and plasters, cement and concrete, timber, steel, roofing materials, miscellaneous materials and components, design of buildings, construction of foundations, walls, floors and roofs, and water supply and sanitation.
3. TOOL, *Rural Building Course (Vol. 1 - Reference, Vol. 2 - Basic Knowledge, Vol. 3 - Construction, Vol. 4 - Drawing Book)*, Intermediate Technology Publications Ltd., London, 1995, ISBN 1 85339 310 X (Vol. 1), 1 85339 315 0 (Vol. 2), 1 85339 320 7 (Vol. 3), 1 85339 325 8 (Vol. 4)
A comprehensive four volume set covering many aspects of small-scale construction. Details included on tools for building, building materials, building components, masonry and carpentry techniques, foundations, floors, walls roofs, finishing, wells and sanitation.

Drawings of the construction details are presented in Volume 4, focusing mostly on housing construction.

4. Gut, Paul, *Roof Structure Guide - Basics for the Design and Construction of Lightweight Sloped Roof Structures (FCR / MCR Toolkit - Element 24)*, SKAT / ILO, St. Gallen / Geneva, August 1993, ISBN 3-908001-27-7 (SKAT) 92-2-109005-1 (ILO)
Full document can also be downloaded in .pdf format; note very large files
http://www.gtz.de/basin/publications/skat/Roofing/MCR%20Toolkit%20Series/TK24_Roof%20Structure%20Guide.pdf
http://www.gtz.de/basin/publications/skat/Roofing/MCR%20Toolkit%20Series/Outil24_La%20Charpente.pdf (in French)

The guide covers how roof structures carry load and resist forces, types and shapes of pitched roofs, design principles, use of timber, bamboo, pole timber, metal and concrete as roof structure materials, the roof structure construction process and maintenance.

5. Schwitter, Daniel (Ed.), *Roof Truss Guide - Design and Construction of Standard Timber and Steel Trusses (FCR / MCR Toolkit Element 29)*, SKAT, St. Gallen, Switzerland, 1999, ISBN 3-908001-85-4 -
Detailed design guidelines and drawings for roof trusses.
6. Gut, Paul, *Roof Cover Guide - Design and Construction of FCR / MCR Roof Covering: Principles, Detailing (FCR / MCR Toolkit Element 25)*, SKAT / ILO, St. Gallen / Geneva, August 1993, ISBN 3-908001-27-7 (SKAT) 92-2-109006-X (ILO)
Full document can also be downloaded in .pdf format; note very large files
http://www.gtz.de/basin/publications/skat/Roofing/MCR%20Toolkit%20Series/TK25_Roof%20Cover%20Guide.pdf
http://www.gtz.de/basin/publications/skat/Roofing/MCR%20Toolkit%20Series/Outil25_La%20Couverture.pdf (French version)

This guide gives details about laying tiles on various types of pitched roofs, including details of more complicated areas such as ridges, valleys and pyramids. Ceilings are also discussed very briefly.

7. Stulz, Roland & Mukerji, Kiran, *Appropriate Building Materials: A catalogue of potential solutions*, 3rd Ed., ITDG Publishing, London, 1993, ISBN 1853392251
Details are given on a wide variety of appropriate and low cost building materials. Some construction details are also considered in outline.
8. Joffroy T. & Guillaud H., *Building with Arches, Vaults and Cupolas*, SKAT, St. Gallen, Switzerland, 1994, ISBN 3908001617
Basic information is presented on the characteristics and building of arches, vaults and cupolas.
9. Building Advisory Service and Information Network (**basin**) website:-
<http://www.gtz.de/basin/>
This contains a wide range of information and links on appropriate building technologies, especially in the knowledgebase (<http://www.gtz.de/basin/knowledgebase/>) and publications (<http://www.gtz.de/basin/publications/>) sections. Note that some of the publications listed, such as the four on the roof structure and cover shown above, can be downloaded, usually as .pdf files. Note that there are two case studies produced by SKAT on secondary school building projects, so these were quite large individual projects. These are:-
Education Development Project, School Infrastructure, Laos (1999) -
<http://www.gtz.de/basin/publications/skat/ef1-99.pdf>
Rural School Construction in Nicaragua (2000) -
<http://www.gtz.de/basin/publications/skat/ef2-00.pdf>

10. Designshare, The International Forum for Innovative Schools - <http://www.designshare.com/>
The focus of this website is largely on schools in Western countries, North America in particular. It includes details on articles and a newsletter. The most important component is the design awards, where featured school buildings are described and plans, drawings and photographs presented.
11. Dierkx, René, *Toward Community-Based Architectural Programming and Development of Inclusive Learning Environments in Nairobi's Slums*, Children, Youth and Environments Vol. 13, No.1 (Spring 2003), [http://cye.colorado.edu/Vol13\(1\)Articles/CYE_CurrentIssue_Article_CommunityBasedArch_Dierkx.htm#Fig10](http://cye.colorado.edu/Vol13(1)Articles/CYE_CurrentIssue_Article_CommunityBasedArch_Dierkx.htm#Fig10)
An interesting article by way of background covering the re-design of schools in slums in Nairobi involving incorporation of children's ideas in the design
12. School / Shelter Hazard Vulnerability Reduction Resource Page, Caribbean Disaster Mitigation Project - <http://www.oas.org/en/cdmp/schools/schlrcsc.htm>
A comprehensive information resource on reducing natural hazard vulnerability of schools, focused on the Caribbean. Numerous links to other resources are provided. Maintenance is also considered in some detail.
13. CSIR / Butek, Facilities Planning & Management, Education and Community Buildings Planning & Design - http://www.csir.co.za/plsql/ptl0002/PTL0002_PGE100_LOOSE_CONTENT?LOOSE_PAGE_NO=7001498
Short case studies of a small number of school building projects in South Africa are presented. Some downloads (large files) of reports are also available.
14. Kill o' the Grange National School, County Dublin, Ireland http://homepage.tinet.ie/~kogrango/building_project_wk51-52.html
Although not in a developing country context this site is quite useful in that it presents a step by step account of how building of the new primary school is actually taking place.
15. Carlqvist, B., *Maintenance of Institutional Buildings, A Management Perspective*, Building Issues, Vol. 9, 1997 (1), Lund Centre for Habitat Studies, Lund University, Sweden
Focuses on the need for building maintenance, why and how buildings deteriorate and processes for maintenance.
16. Whitby, Garry, *Primary Community School Construction*, Appropriate Technology, Vol. 25, No. 1, June 1998, pp. 30 - 32

A short case study on a rural school building programme in Malawi focusing on planning, building technologies, site selection, design and layout, community participation, tendering, gender strategy and training and capacity building.