

**AT** MICROFICHE  
REFERENCE  
LIBRARY

A project of Volunteers in Asia

Piston Water Pump  
Publication No. T-114

Published by:  
Brace Research Institute  
MacDonald College  
McGill University  
Ste. Anne de Bellevue 800  
Quebec, Canada H9X 1C0

Paper copies are \$ 5.00.

Available from:  
Brace Research Institute  
MacDonald College  
McGill University  
Ste. Anne de Bellevue 800  
Quebec, Canada H9X 1C0

Reproduced by permission of the Brace Research  
Institute, McGill University.

Reproduction of this microfiche document in any  
form is subject to the same restrictions as those  
of the original document.

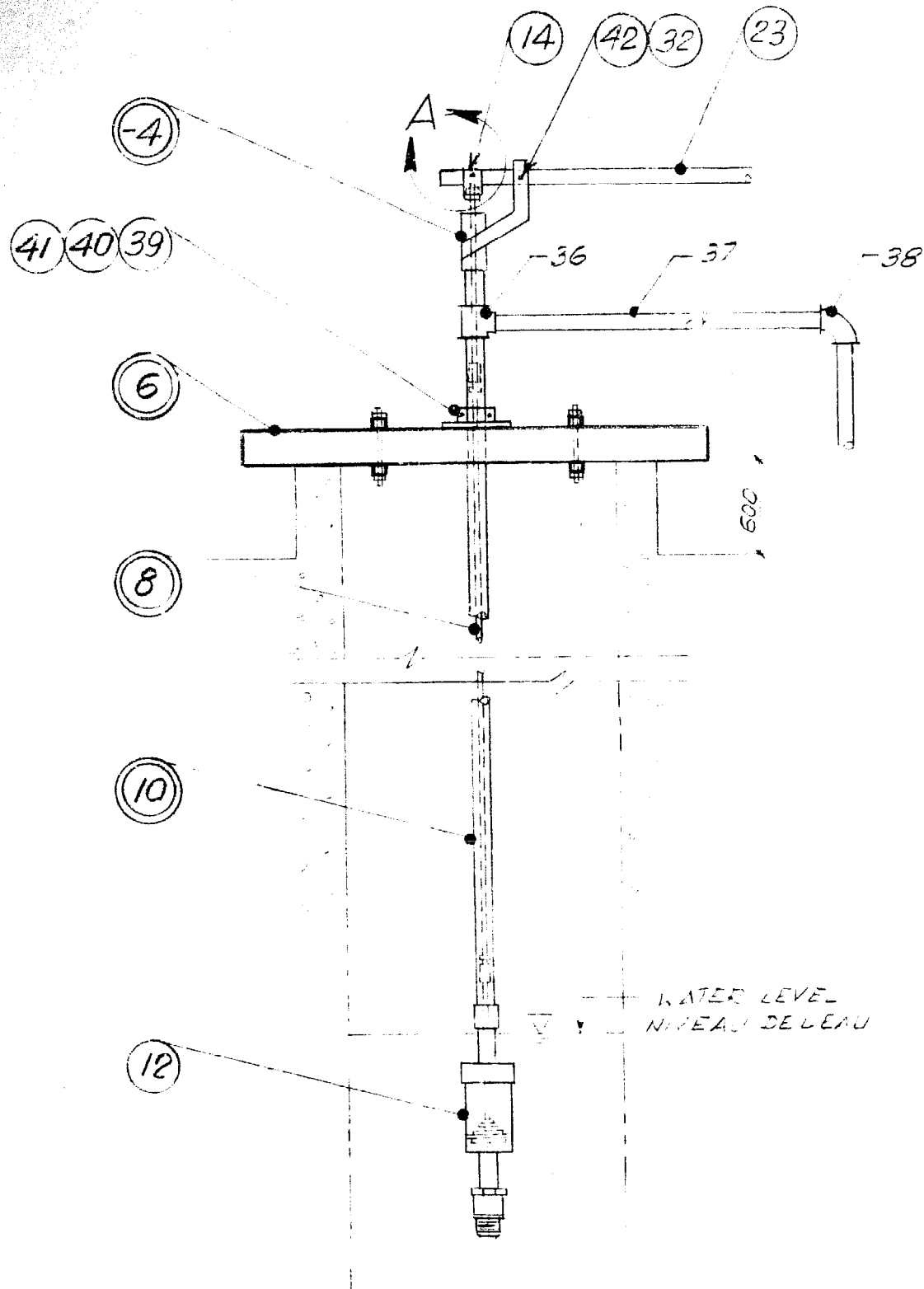

**(-2) INSTALLATION**

NOT TO SCALE

PAS D'ECHELLE

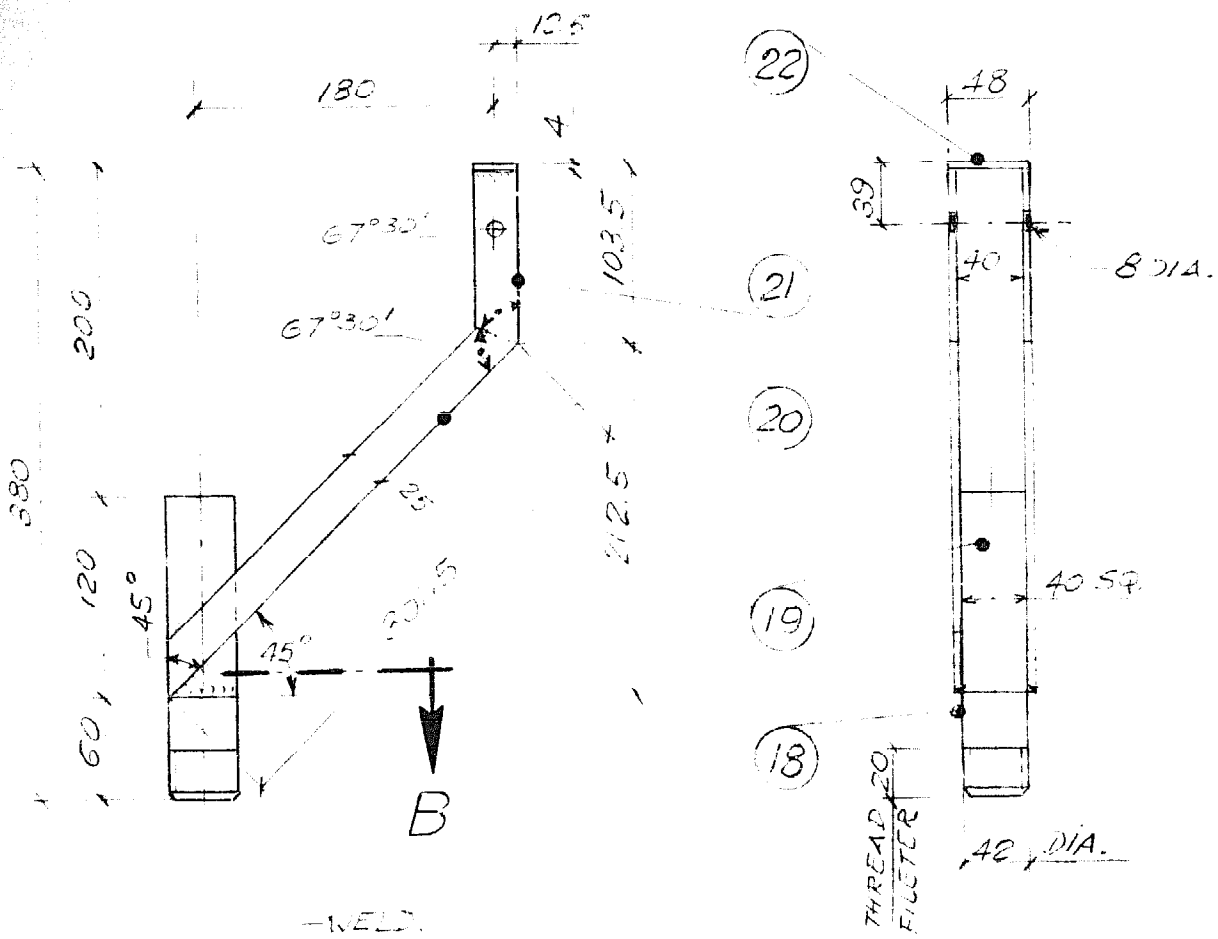

SECTION B

④ ASSY. ASSEMBLAGE  
1:40

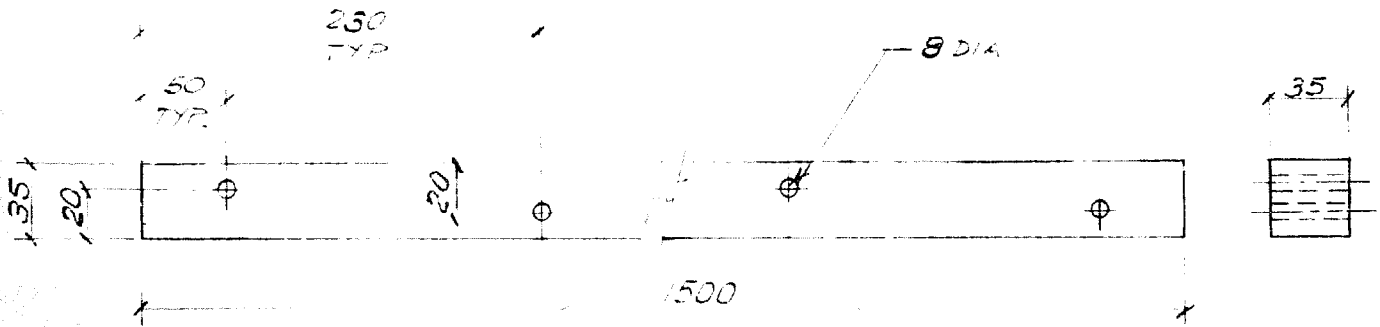

③

NOT TO SCALE  
PAS. DISCELLE

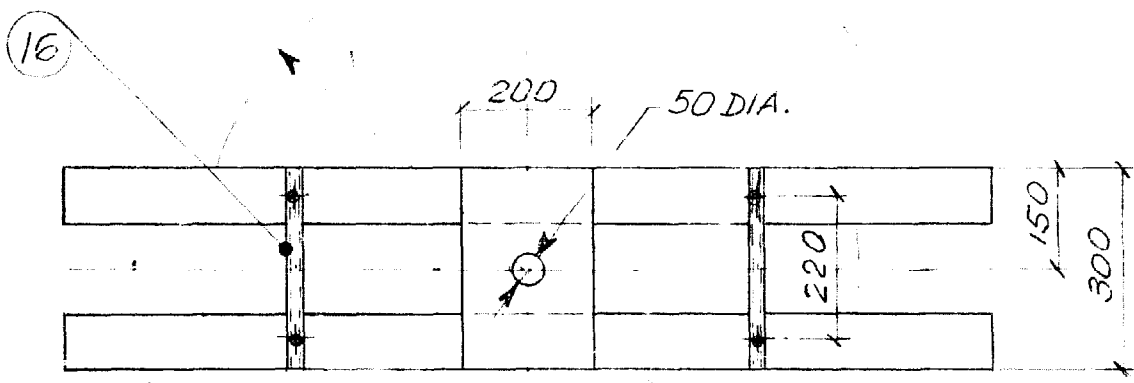
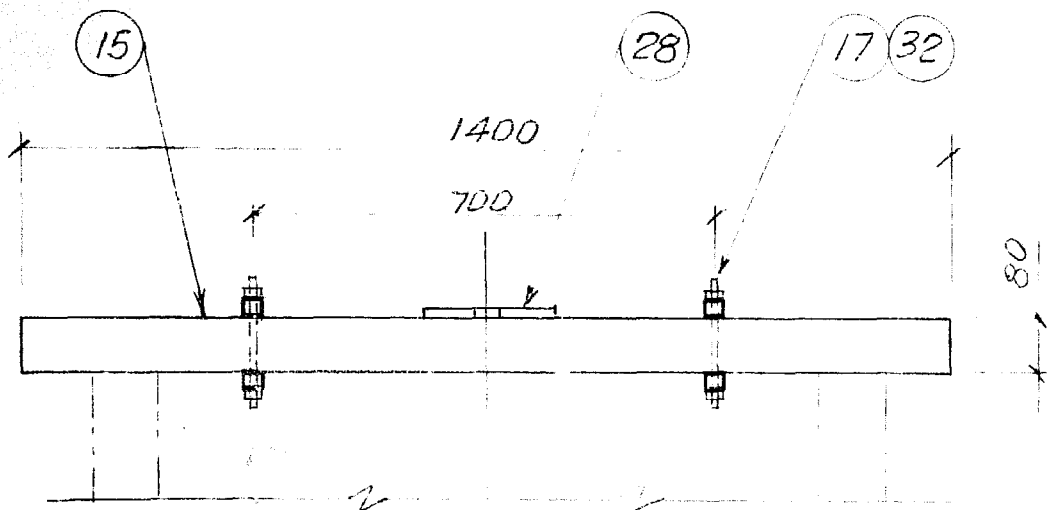

-1000 DIA.

(-6) ASSY. ASSEMBLAGE  
1:10

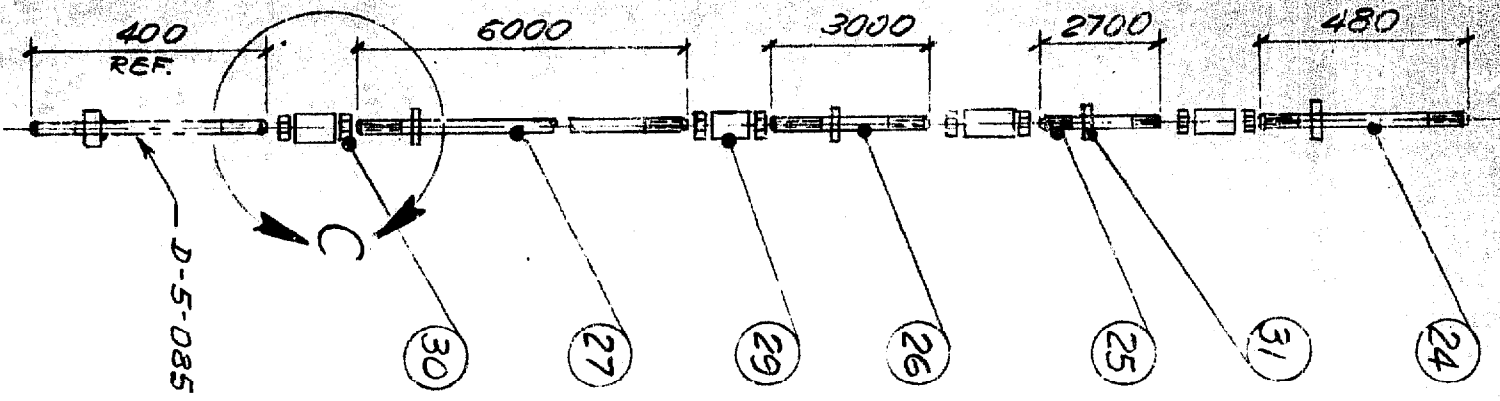

**(8) ASSY.**

NOT TO SCALE  
PAS D'ECHELLE

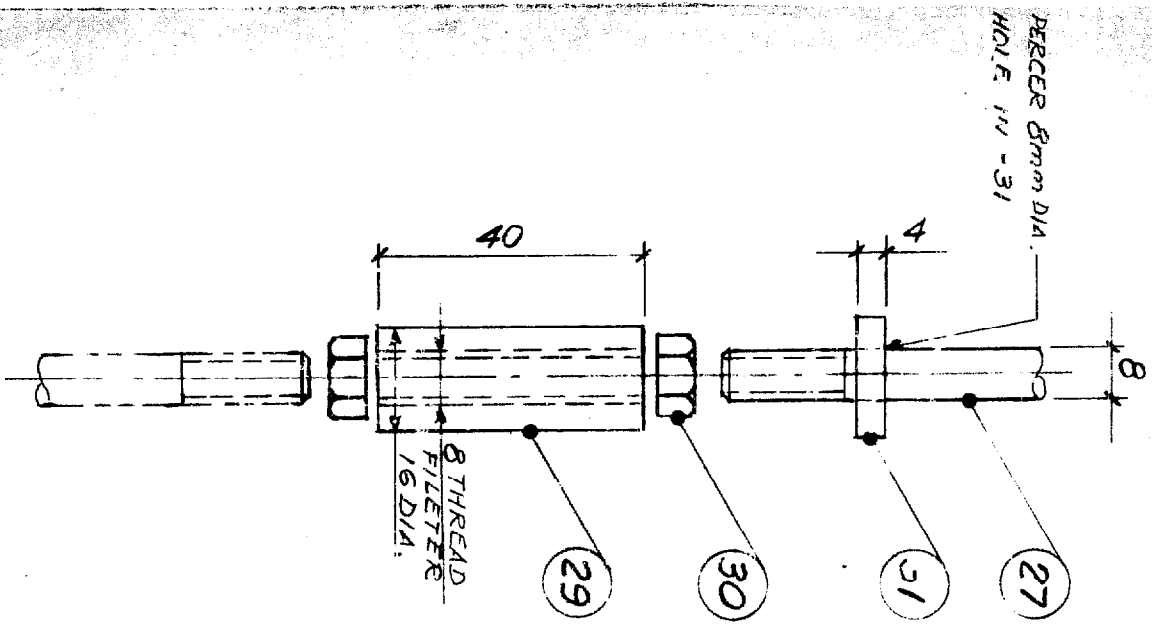

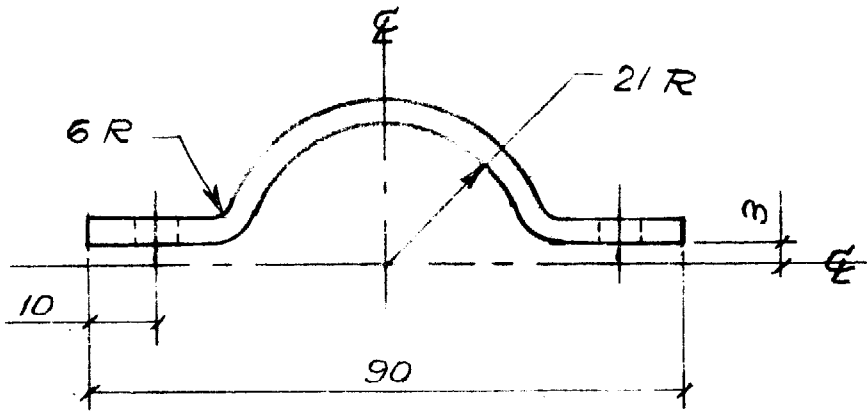
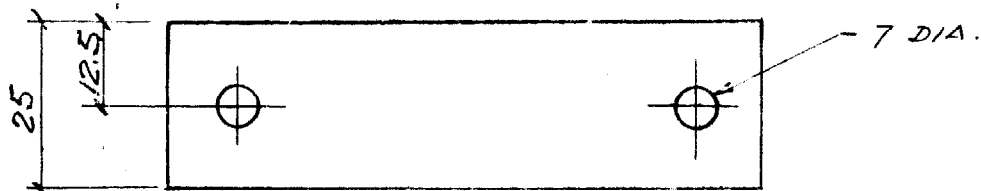
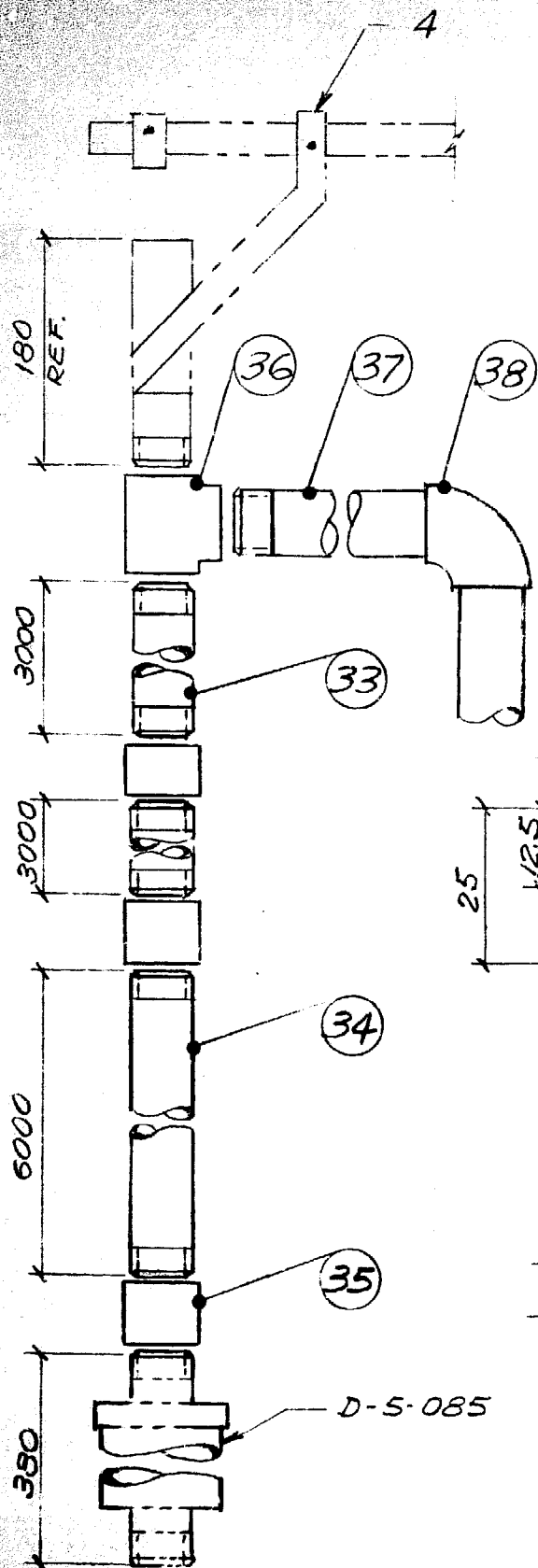

(39) 1:1

(-10) ASSY. - ASSEMBLAGE  
NOT TO SCALE  
PAS D'ECHELLE

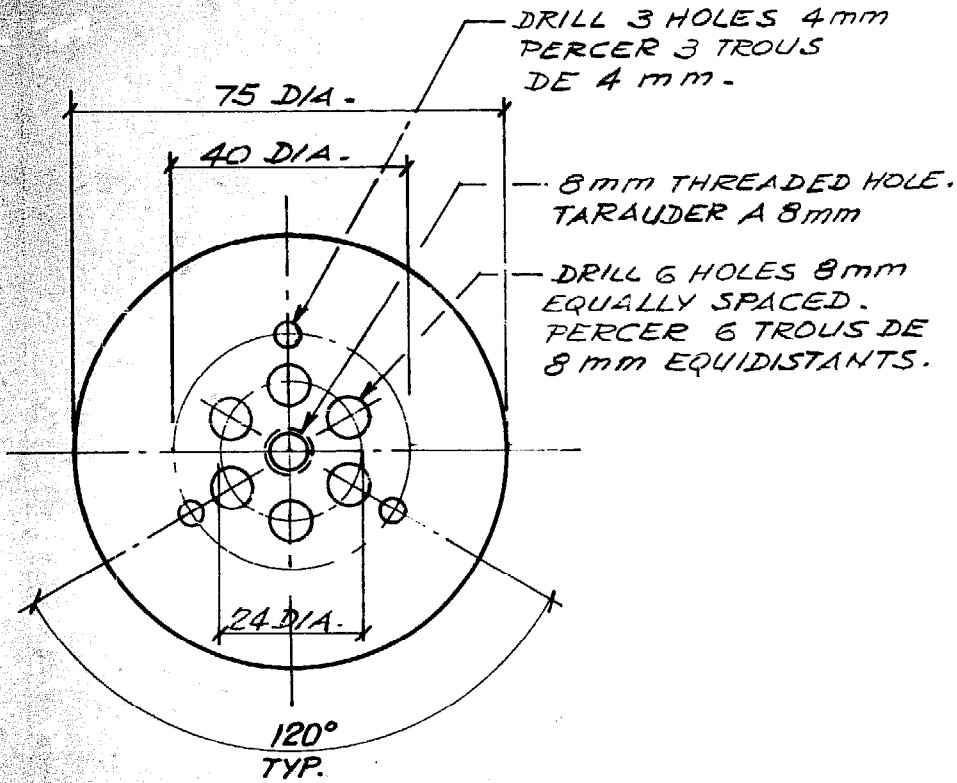

(26)

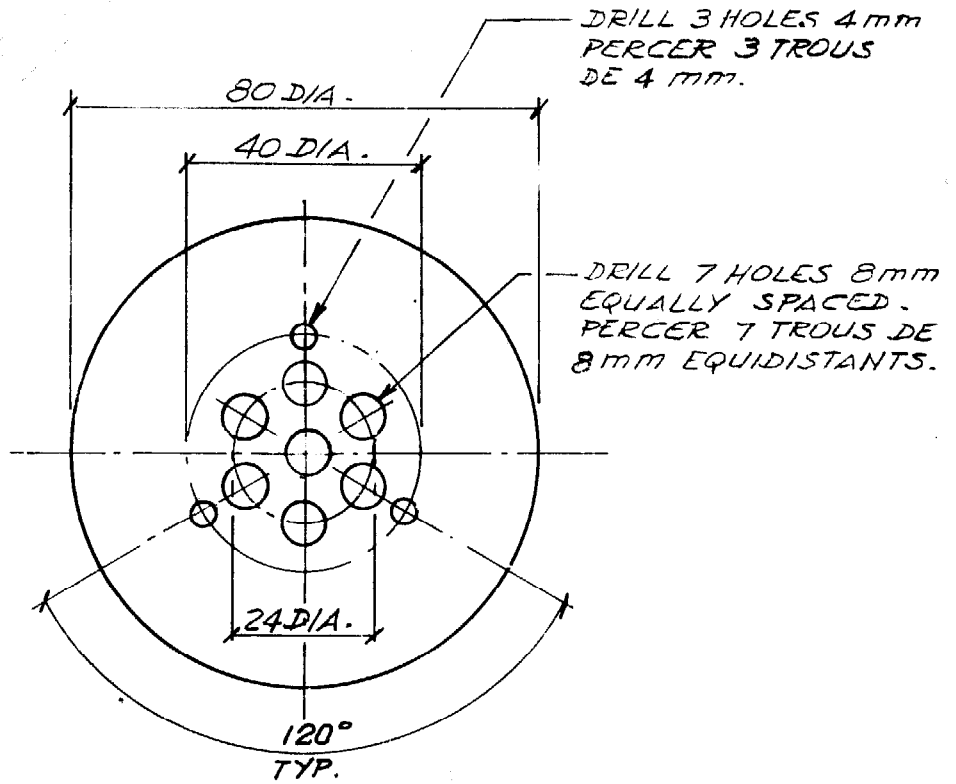

(24)

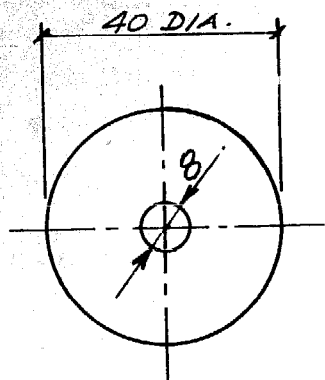

(22)

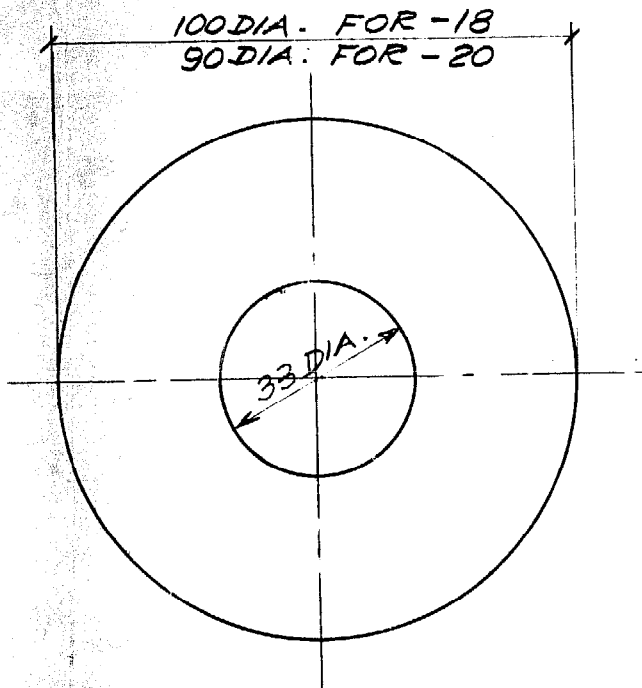

(18)

(20)

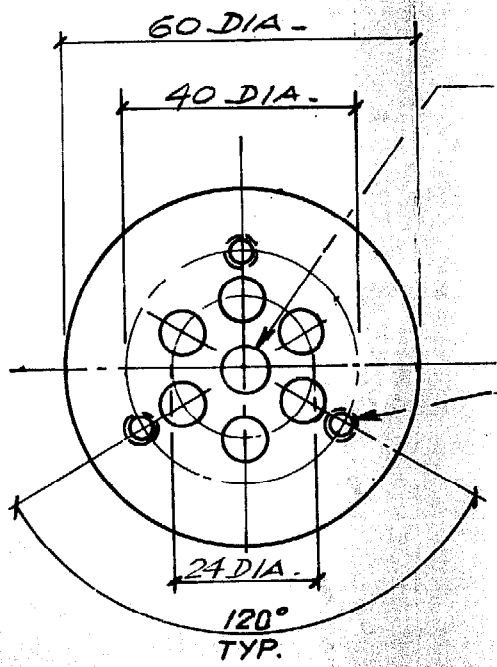

DRILL 7 HOLES 8mm  
EQUALLY SPACED.  
PERCER 7 TROUS DE  
8 mm EQUIDISTANTS.

3 HOLES THREADED 4mm  
TARAUDER 3 TROUS DE 4mm.

(28)



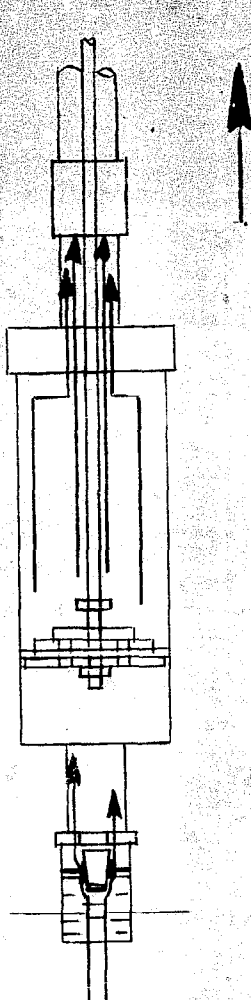

FIG. 1 A

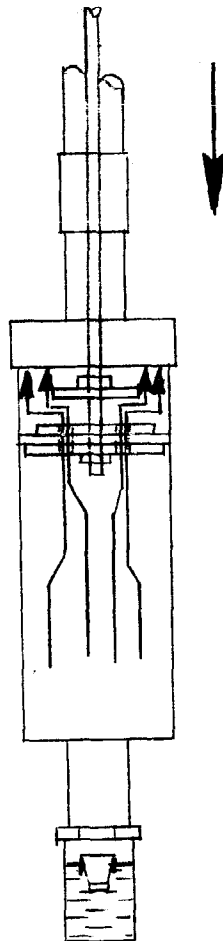

FIG. 1 B

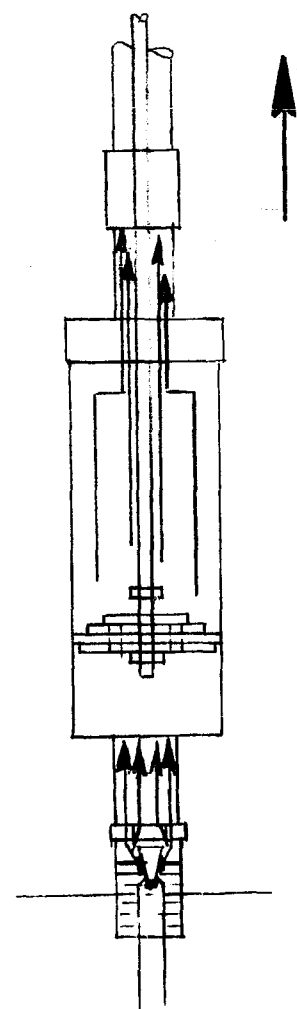
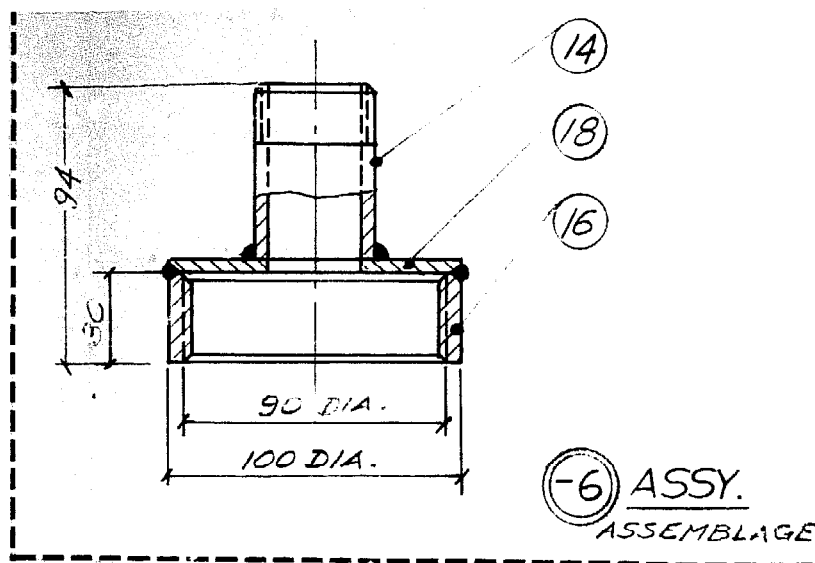

FIG. 1 C

PUMP OPERATIONAL STEPS  
SCHÉMAS DE FONCTIONNEMENT DE LA POMPE



	1		36	ECROU DE 8mm ALÈSE / NUT BORED AT 8mm		
	3		34	ROUND HD. SCREW / VIS A TÊTE RONDE 4mm		
	1		32	NUT / ECROU DE 8mm		
	1		30	IRON ROD / TIGE DE FER ROND 8mm		
	1		28	STEEL PLATE / RONDELLE DE MÉTAL 4mm		
	1		26	STEEL PLATE / RONDELLE DE MÉTAL 4mm		
	1		24	RUBBER WASHER / RONDELLE DE CAOUTCHOUC 5mm		
	1		22	RUBBER WASHER / RONDELLE DE CAOUTCHOUC 5mm		
		1	20	BLACK STEEL PLATE / PLAQUE D'ACIER NOIRE 4mm		
		1	18	BLACK STEEL PLATE / PLAQUE D'ACIER NOIRE 4mm		
		1	16	COUPLING / MANCHON	90mm / 100mm	
		1	14	GALV. PIPE / TUYAU GALVANISE	33mm / 42mm	
		1	12	GALV. PIPE / TUYAU GALVANISE	80mm / 90mm	
		1	10	PISTON		
	1		8	PISTON ROD / TIGE DU PISTON		
			6	ASSY. / ASSEMBLAGE		
			4	ASSY. / ASSEMBLAGE		
			2	ASSY. / ASSEMBLAGE		
-10-8-6-4	-2	ITEM		DESCRIPTION	MATERIAL MATERIEL	SIZE DIMENSION

**BRACE RESEARCH INSTITUTE  
OF MCGILL UNIVERSITY**

PISTON WATER PUMP  
POMPE À EAU À PISTON

SCALE 1:1 & 1:2

MACDONALD CAMPUS  
STE. ANNE DE BELLEVUE  
P.Q., CANADA

DRAWN O. G. Mar 77

CHECKED *Baldwin* Mar 77

ASSEMBLY

DWG. No. D-5-085

T-114 \$5.00