

AT MICROFICHE
REFERENCE
LIBRARY

A project of Volunteers in Asia

Manual on the Design, Construction and Maintenance
of Low-Cost Pour-Flush Waterseal Latrines in India

by A.K. Roy et. al.

Published by:

Technology Advisory Group
World Bank
1818 H St. N.W.
Washington D.C. 20433
USA

Available from:

same as above

Reproduced by permission.

Reproduction of this microfiche document in any form is subject to the same restrictions as those of the original document.

TAG Technical Note Number 10

United Nations Development Programme
Interregional Project INT/81/047
Executing Agency: The World Bank

Manual on the Design, Construction and Maintenance of Low-Cost Pour-Flush Waterseal Latrines in India

By A.K. Roy, P.K. Chatterjee, K.N. Gupta,
S.T. Khare, B.B. Rau and R.S. Singh:
Technology Advisory Group (TAG)-India

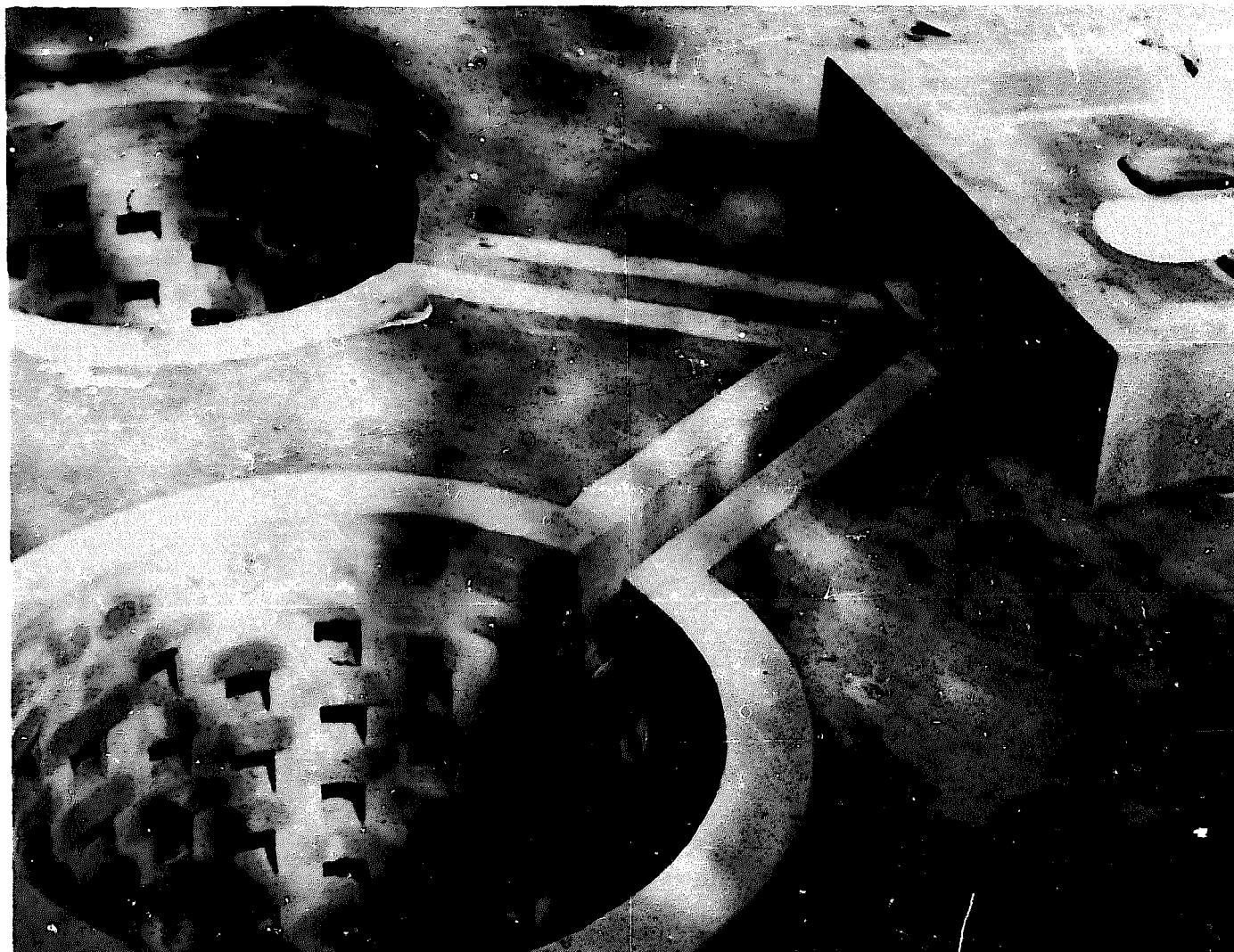

A joint United Nations Development Programme
and World Bank Contribution to the International
Drinking Water Supply and Sanitation Decade

Copyright © 1984

The International Bank for Reconstruction and Development/THE WORLD BANK
1818 H Street, N.W.
Washington, D.C. 20433, USA

All rights reserved

Manufactured in the U.S.A.

TABLE OF CONTENTS

	<u>Page</u>
Preface	i
Foreword	ii
Chapter I: Introduction	1
Chapter II: Technology and Design	4
Pour-flush latrine	4
Design and materials for latrine units	4
Squatting pan	4
Trap	4
Foot-rests	5
Connecting drain or pipe to pits	5
Leach pits	5
Size and shape	5
Siting	6
Location	7
Distance between two pits	7
Distance from existing structures	7
Depressions and water-logged areas	8
Location in drainage line	8
Water pollution aspects	8
Safe distance from drinking water sources	9
Safe distance from water supply mains	11
Viral pollution	12
Lining of pits	12
Brick or stone masonry lining	12
Use of rings for lining	12
Pit covers	13
Suitability of leaching pits in black cotton soil	13
Standard designs	13
Superstructure for latrine	13
Community latrines	14

	<u>Page</u>
Chapter III: Institutional Requirements	15
A Suitable Institution	15
Orientation and training	16
Methodology for construction of household latrines	16
Communication support: publicity, promotion and health education	17
Procedure for getting a latrine constructed	17
Supervision charges	19
Legal amendments	19
Chapter IV: Mobilization of financial resources	21
Financing pattern	21
Disbursement of funds	22
Recovery of loans	22
Repayment by the local authority to the lender	23
Chapter V: Construction	24
Materials	24
Materials to be supplied by the implementing agency	24
Materials to be arranged by the contractor	24
Slabs for covering pits and junction chambers	24
Casting of RCC slabs and domes	24
Stone slabs	25
Fixing of pan, trap and footrests	25
Connection to pits	25
Drain	26
Pipe	26
Junction chamber	26
Lining of leach pits	26
Brick work	26
Stone masonry	27
Stone pitching	27
Burnt clay rings	27
Curing	28
Flooring	28
Site clearance	28
Specifications	28
Supervision	28

	<u>Page</u>
Chapter VI: Operation and maintenance	30
Maintenance of household latrines	30
Operation and maintenance of public latrines	31
Annex I: Studies conducted	32
Annex II: Drawings	
No. 1 Pan and trap	33
No. 2 Drain and junction chamber	34
No. 3 Foundation and plinth of superstructure.....	35
No. 4 Details of superstructure.....	36
No. 5 Latrine with leach pits within premises	37
No. 5A Design of RCC covers	38
No. 6 Details of reinforcement for RCC slab	39
No. 7 Latrine with leach pits under foot-path	40
No. 7A Details of pit roofs	41
No. 8 Details of reinforcement for RCC dome for pit under footpath	42
No. 9 Latrine with leach pits under road	43
No. 10 Details of reinforcement for RCC slab and dome for pits under road	44
No. 11 Layout plan of leach pits in different situations...	45
No. 12 Layout plan of leach pits in different situations...	46
No. 13 Pits within the premises in water logged areas	47
No. 14 Community latrine-8 seated	48
No. 15 Community latrine-12 seated	49
No. 16 Community latrine-16 seated	50
No. 17 4, 6, 8, 10, 12, & 16 seated community latrine, detail at A	51
Annex III: Estimates	
Conversion of bucket/dry latrine with leach pits within premises	52
Conversion of dry/bucket latrine with leach pits under footpath	54
Conversion of dry/bucket latrine with leach pits under road	56
New pour-flush latrine with leach pits within premises	58
New pour-flush latrine with leach pits under footpath	60
New pour-flush latrine with leach pits under road	62

	<u>Page</u>
Covered brick drain	64
Junction chamber	65
Foundation and plinth for superstructure	66
Superstructure of latrine cubicle	67
Leach pit within premises	68
Leach pit under footpath	69
Leach pit under road	70
Community latrine--8 seated	71
Community latrine--12 seated	73
Community latrine--16 seated	75
Materials and labor required for conversion of dry latrine with pits within premises	77
Materials and labor required for conversion of dry latrine with pits under footpath	78
Materials and labor required for conversion of dry latrines with pits under road	79
Materials and labor required for construction of a new latrine with leach pits within premises	80
Materials and labor required for construction of a new latrine with pits under footpath	81
Materials and labor required for construction of a new latrine with leach pits under road	82
Annex IV: Forms	83
No. 1 Notice	84
No. 2 Application for construction of a pour-flush latrine to be given by house-owner	85
No. 3 Application for construction of a pour-flush latrine to be given by tenant	86
No. 4 Recommendation of the technical authority of the implementing agency	87
No. 5 Certificate for locating the pits under footpath or road	88
No. 6 Letter to the applicant sanctioning the construction	89
No. 7 Loan agreement with the beneficiary	91
No. 8 Work order and intimation to house-owner	94
No. 9 Completion certificate	98
No. 10 Instruction for operation and maintenance of pour-flush latrines	100
No. 11 Guarantee card	103
Annex V: Model by-laws for regulating the construction, operation and maintenance of latrines	104

PREFACE

This manual on the Design, Construction and Maintenance of Low-cost Pour-Flush Waterseal Latrines in India is one of a series of informal Technical Notes prepared by TAG^{1/} on various aspects of water supply and sanitation programs in developing countries. The papers were originally prepared as internal discussion documents; their wide distribution does not imply endorsement by the sector agencies, government, or donor agencies concerned with the programs, nor by the World Bank or the United Nations Development Programme. Comments and suggestions on the papers should be addressed to the Project Manager, UNDP Project INT/81/047, Water Supply and Urban Development Department, The World Bank, 1818 H Street, NW, Washington, DC. 20433.

SUMMARY

This manual has been prepared for agencies, contractors and individuals involved in various aspects of the low-cost pour flush waterseal latrine program in India. The inherent principles are, however, of general application, and, with minor modifications, the technical details can be readily adapted to meet the needs of different areas, particularly where water is used for ablutions. The manual provides the salient features of design, construction and maintenance as well as the administration of low-cost pour-flush waterseal latrines with off-set twin pits. It contains extensive drawings, tables of quantities of materials for different designs as well as standard forms for by-laws and for general project administration and supervision.

^{1/} TAG: Technology Advisory Group established under the United Nations Development Programme Global Project GLO/78/006 (renumbered on January 1, 1982; now UNDP Interregional Project INT/81/047), executed by the World Bank.

FOREWORD

There is no denying that safe water supply is a very important component in the overall strategy for achievement of health goals; but the rewards can be fully reaped only if sanitation keeps pace with provision of water supply. Unfortunately, developing countries which are buckling under the pressure of scant resources have not been able to lend support to this philosophy and have perforce to adopt a piecemeal approach. However, the situation is not bleak, since the commitments with regard to safe water supply are almost well nigh fulfillment and the time is fast approaching for bestowing serious thought on this aspect of sanitation.

Perhaps water supply has been able to attract attention of the people not only because of its health implications but also from the view point of being a convenience for which the community is willing to pay. Proper disposal of domestic wastes, however, has not this advantage and motivation has to be to a greater degree than in the case of water supply. The traditional system of conservancy has to slowly give way to alternative cleaner and safer systems because of:

- (a) the health considerations associated with exposed nightsoil,
- (b) the desire of the community for a cleaner and aesthetic system born out of the rising living standards and education, and
- (c) the society's demand for doing away with the degrading practice of human beings carrying nightsoil loads.

The sewerage system which has been the solution in developed countries and warrants heavy investments could be afforded only by very large communities and is far beyond the paying capacity of the smaller communities. Moreover, this will call for a high technology with sophisticated treatment systems with proper qualified personnel for operation and maintenance. There is, therefore, an urgent need for evolving a viable alternative which has several of the merits in-built, environmentally and aesthetically sound and within the easy reach of the community. The International Drinking Water Supply and Sanitation Decade has for its targets the adoption of sewerage system for all Class I cities, with other low cost sanitation measures being adopted in other towns to give an overall coverage of 80%.

Considerable research and development has been witnessed in the country in the evolution of low cost methods. The "Low Cost Sanitation with On-site Excreta Disposal System" developed by the UNDP Global Project eminently meets with all the promise of a safe and sound system and can serve as an intermediate technology within the affordable reach of and immediate adoption by several urban communities in our country. The Project Team of the UNDP Global Project have worked out all the design criteria for the pan and trap and the dual pit along with the cost involved in the "Water Seal Pour-Flush Latrines." Workability of this system has also been established through a few demonstration projects.

However, the need for bringing home the message to the people and promoting its large scale use would be the immediate charge of all those concerned with sanitation. Sanitation, if it has to succeed, must be made 'a way of life', and it is time that we got into this serious business of entering into a direct dialogue with the people, whose participation in the sector, more than elsewhere, we need in a large measure if our endeavour has to be crowned with success.

(V Venugopalan)
Adviser (PHEE) and National Director for
UNDP Project on Low-Cost Sanitation,
Ministry of Works & Housing,
Government of India

ACRONYMS USED IN THIS MANUAL

AC	Asbestos Cement
AIIPH	All-India Institute of Hygiene and Public Health, Calcutta
CBRI	Central Building Research Institute, Roorkee
cm	Centimetre
cu	Cubic
dia	Diameter
ES	Effective Size (of soil)
GRP	Glass Fiber Reinforced Polyester Plastic
GOI	Government of India
HDPE	High Density Polyethylene
ISI	Indian Standards Institution
ISS	Indian Standard Specifications
m	Metre
mm	Millimetre
m ²	Square Metre
m ³	Cubic Metre
NEERI	National Environmental Engineering Research Institute, Nagpur
PHED	Public Health Engineering Department
PRAI	Planning Research-cum-Action Institute, Lucknow
PVC	Polyvinyl Chloride
PWD	Public Works Department
RCA	Research-cum-Action
RCC	Reinforced Cement Concrete
RR	Random Rubble (used with stone masonry)
Sq	Square

TAG **Technology Advisory Group, UNDP, operating under UNDP Project
INT/81/047, executed by the World Bank**

UNDP **United Nations Development Programme**

UNICEF **United Nations Children's Fund**

WHO **World Health Organization**

CHAPTER I

INTRODUCTION

1.1 Human excreta is associated with more than fifty diseases and it causes nearly 80% of sickness in India. With proper disposal of human excreta by inexpensive methods, these diseases can be brought under control and the entire sanitation situation of the country can be improved. Studies have established that without proper sanitation the full health benefits of providing safe water supply are not achieved.

1.2 To begin with, all existing dry latrines^{1/} should be converted into water-flushed ones to reduce the present insanitary conditions; subsequently, sanitary latrines should be provided for use of householders who have none at present. Sewerage and sewage disposal would have been the ideal solution but the cost is prohibitive. Even with fairly intensive efforts over the 30 years since the launching of the National Water Supply and Sanitation Program in India, only about 200 out of 3,245 towns have been sewerred. The coverage even in these towns is partial (hardly 10-30% houses have service connections). On account of prohibitive costs, even the targets for the International Drinking Water Supply and Sanitation Decade of the country restrict sewerage to Class I cities (population 100,000 and above) and envisage overall coverage of only 80% of all urban areas (including Class I cities) with either sewerage or sanitary toilets. Septic tanks with proper effluent disposal could be an alternative, but these require periodic safe removal and treatment of the accumulated liquid sludge, a service which has often proved unreliable. The septic effluent is also a potential medium for mosquito breeding and may cause health hazards if not properly disposed of through sub-surface drainage systems. The high cost of septic tank systems put them beyond the reach of average households; this has led to the search for alternative, more affordable solutions. Pour-flush waterseal latrines with excreta treatment in twin leach pits obviate these disadvantages; they are economical, and offer a long-term and appropriate solution for excreta disposal until provision of a sewer system can be afforded. Then these latrines could be connected to sewers at minimal cost. This system will result not only in the relief of insanitary conditions but will also eliminate insect and fly breeding due to open defecation, as well as minimizing hookworm and other infestations which reduce human productivity.

1.3 It could be argued that this solution would be feasible only in rural areas, where the population density is low and the required space might be available, and that it may lead to pollution of groundwater if adopted on a large scale in urban areas. So far more than 400,000 pour-flush waterseal latrines have been constructed in the towns of India, many in densely populated areas. House-to-house information covering the entire households in over 110 representative towns surveyed under the United Nations Development Programme (UNDP) Global Project on Low-Cost

^{1/} Bucket privies, emptied by scavengers

Water Supply and Sanitation (1979-81) has revealed that feasibility in any particular urban area varies from 75% to 100% of the households concerned. An Expert Group on the leaching pit system of latrines, formed by the Technology Advisory Group (TAG)-India and consisting of eminent scientists and sanitary engineers of India, made an in-depth study of the design criteria for pour-flush latrines. After assessing a number of research studies carried out around the world on groundwater and soil pollution aspects, it was concluded that there is no risk in adopting this system in the vast majority of hydrogeological conditions and that even in many unfavorable conditions suitable remedial measures can be taken. More details are provided in Chapter II.

1.4 GOI sought the assistance of the UNDP Global Project GLO/78/006 (now renumbered as INT/81/047). The Projects INT/81/047 and IND/81/014, with the World Bank as the executing agency, have recommended in their feasibility studies a design which takes into account the various parameters developed not only in India but also elsewhere and their critical evaluation from various aspects, including considerations of technical and social feasibility and cost-effectiveness.

1.5 Pour-flush waterseal leach pit latrines were first developed in India in the mid-1940s at the Singur field center of the All-India Institute of Hygiene and Public Health (AIHPH), Calcutta. Since then further development and research have been continued by this Institute. The technology was originally meant for rural areas. The main design feature was that there was a single leach pit with a squatting pan placed directly over it. When the pit in use was filled, another pit was dug and the same squatting slab was transferred to the new pit. The first pit was covered with earth and the excreta was allowed to digest. It was removed later for use as manure.

1.6 In the mid-1950s the same system was adopted in the Research-cum-Action Projects (RCA) sponsored by GOI at Poonamallee (Madras), Najafgarh (Delhi) and Singhur (Calcutta).

1.7 It was in the late 1950s that the WHO/UNICEF-sponsored project^{2/} at the Planning, Research-cum-Action Institute (PRAI) at Lucknow, Uttar Pradesh (UP) which was supported by GOI and the Government of UP developed the design of the off-set system by placing the leach pit away from the latrine seat instead of underneath the squatting pan. The off-set system has the advantage that a second pit can be constructed before the pit in use becomes full; furthermore the squatting slab need not be removed, and a new latrine cubicle does not have to be constructed. Thus, the existing waterseal latrine can be used immediately after the first pit is full. The cover of the used leach pit is then transferred to the new one, and the used pit is covered with earth. This off-set system was also developed for rural areas; to save cost the second pit and its cover were not provided in the first instance.

^{2/} WHO: World Health Organization; UNICEF: United Nations Children Fund.

1.8 The design adopted in this manual for urban areas is based on the off-set leaching pit system with twin pits to be constructed at the same time, so that there is no later work involved in digging the second pit. This is necessary especially in the urban areas for which this manual has been prepared.

1.9 With the massive conversion of dry bucket latrines into pour-flush ones contemplated in the country, there is a strong need for a manual to help people responsible for the program. This manual describes the salient features of design, construction and maintenance of low-cost pour-flush latrines; it is based on the world-wide studies and recommendations of the above named Expert Group, as well as those of the UNDP Global Project (See Annex I) and the premier engineering research and development institutions in the country, such as the Central Building Research Institute (CBRI) in Roorkee, the National Environmental Engineering Research Institute (NEERI) in Nagpur, the Indian Council of Medical Research (ICMR) in New Delhi, the Public Health Institute (Poonamallee), the All-India Institute of Hygiene and Public Health in Calcutta, the RCA Project, and PRAI in Lucknow.

1.10 The GOI objectives described in paragraph 1.2 above cannot be achieved unless a firm program is adopted for providing each and every household with a waterseal latrine in a time-bound program. Chapter II describes design types for possible use under Indian conditions for households with 5, 10 or 15 persons, and with the leach pits located within the premises, outside the premises, under footpaths and under roads. With a view to providing an affordable facility to poorer people, superstructure alternatives in tune with their housing structure have been considered.

1.11 Evaluation studies carried out by TAG in the urban areas of Bihar, Gujarat and Tamil Nadu have indicated that, for the successful implementation of such a massive program, careful attention must be paid to optimizing organization and financial patterns; these are discussed in Chapters III and IV respectively. The enthusiastic involvement of non-technical personnel such as municipal administrators of different local authorities and individual householders is essential for speedy and effective implementation. Details of (a) construction, (b) operation and maintenance, (c) draft forms, (d) drawings, and (e) estimates are given in Chapters V and VI and in Annexes to this manual.

1.12 This is only one effort in the ever-continuing search for a still better low-cost solution. Suggestions for improvements are welcome.

CHAPTER II

TECHNOLOGY AND DESIGN

Pour-Flush Latrine

2.1.1 The pour-flush waterseal latrine consists of a squatting pan with a steep bottom slope (25° to 30° to the horizontal) and a 20 mm waterseal trap, set in a cement concrete floor. After use it is flushed by hand using a small container holding about 1.5 to 2 litres of water. The excreta are carried through a pipe or drain into two honeycomb leach pits, which are used alternately. The liquid in the pits percolates into the sub-soil and gases are absorbed by the soil, leaving the solids behind. Each pit is designed to last for about three years before it gets filled; when one is filled, it is taken out of use and excreta are then diverted to the second pit. When the filled pit is left for about two years, the contents turn into a rich organic humus which is safe for handling. When convenient it is emptied and the contents may be used as manure. It is then ready to be put back into use when the second pit fills up.

2.1.2 With simple care the pour-flush waterseal latrine is a very satisfactory and hygienic sanitation system. It can be located inside the house, since the waterseal prevents odor and insect nuisance.

Design and materials for latrine units

Squatting pan

2.2.1 Details of the squatting pan are shown in Drawing No. 1. The horizontal length of the pan should be at least 425 mm. The pan can be of ceramic, glass-fiber reinforced plastic (GRP), PVC, HDPE, mosaic or cement concrete. Ceramic or GRP pans have many advantages over the concrete ones. They are smooth, require less water for flushing and are more aesthetic. A GRP pan is cheaper, lighter and easier to transport than a ceramic one. The concrete pans are heavy, difficult to transport and get roughened and unattractive after use due to the action of uric acid, but initially they are less expensive [Draft Indian Standard Specifications for a new pan developed through the UNDP Global Project, which would amend ISS 2556 (Part III), 1981, are under consideration by the Indian Standards Institution (ISI).] Meanwhile, pans should conform to ISS 2556, Part III, 1981.

Trap

2.2.2 The trap should be as shown on Drawing No.1. It should be 70 mm. dia with a 20 mm waterseal. Ceramic, GRP, HDPE or PVC traps are smooth and need less water for flushing than concrete ones, but initially cost more (specifications for a new pan design developed through the UNDP Global Project, which would amend ISS 2556 (Part XIII), 1973, are under consideration by ISI. For the present, traps should conform to ISS 2556, Part XII, 1983.

Foot-rest

2.2.3 Footrests should conform to ISS: 2556 (Part X), 1967. They can be ceramic, concrete with mosaic finish, brick or stone. The size of footrest should be 250 mm x 125 mm with 15 to 20 mm height.

Connecting drain or pipe to pits

2.3 The trap should be connected to the pits either by a pipe or a covered drain. If a pipe is used, a junction chamber of minimum size 250 mm x 250 mm internal should be provided at the junction point (Drawing No. 2). The non-pressure AC pipe should be used as it is cheaper, and its size should not be less than 75 mm. The drain can be made of bricks or stones with a minimum size of 75 mm x 75 mm with semi-circular bottom (Drawing No. 2). The slope provided should be 1 in 5 to 1 in 15. Bends and curves in the drain should be avoided. The inlet pipe or drain into the pits should project a minimum of 100 mm into the pits.

Leach pits

Size and shape

2.4.1.1 The size of the leach pits depends upon a number of factors such as: number of users, cleaning interval, soil properties (including its permeability), water table condition, and the quantity of water used for flushing and anal cleansing. A study on sludge accumulation rate carried out by various research institutes in India and UNDP TAG-India Global Project reveals that an effective capacity 0.045 m³ to 0.05 m³ per capita per year has to be provided under dry conditions, and under wet conditions, i.e., where the groundwater table is above the pit bottom at any time during the year, the pit capacity has to be increased.

2.4.1.2 The pit capacities (effective volume^{3/}) for 5, 10 and 15 users with three years pit service, under dry and wet conditions, are as follows:

TABLE 1

Number of users	Effective volume in cubic metres for three years	
	Pit under dry condition	Pit under wet condition
5	0.68	1.0
6	0.81	1.2
10	1.36	2.0
15	2.04	3.0

^{3/} Effective volume is the volume of the pit below invert level of pipe or drain.

2.4.1.3 It has been observed that all pathogens will die off in a period of about two years and thereafter the cleaning operations can be organized depending upon the weather conditions and demand for humus. A minimum storage capacity of three years has been suggested for the leach pits to facilitate cleaning operations. The household strengths of 5 or 6, 10 and 15 cover practically all the Indian households. Based on the recommendations of the National Building Code, GOI, one seat is to be provided for up to 10 users, with two seats for 15 users and more. Each of the twin pits is designed for the required number of users. Based on a cleaning interval of three years, and for 5 users, the recommended effective depth (distance between the invert level of pipe or drain and bottom of the pit) is 1.1 m and the diameter 0.9 m.

2.4.1.4 The pit shape can be circular or rectangular, or a combination of the two. However, circular pits should be constructed wherever feasible as these are more stable and cost less (Drawing Nos. 5, 7 and 9). Where circular pits of standard sizes cannot be dug due to space constraints, deeper and smaller diameter (not less than 0.8 m) pits or oval pits as, shown in Drawing No. 14, may be adopted.

2.4.1.5 More than one latrine seat can be connected to a pair of pits provided the total number of users is not more than that assumed in determining the required capacity of the pits.

2.4.1.6 Providing a freeboard of 200 to 250 mm, the economical sizes of circular dry pits (i.e., with low water table conditions) and in average soils are given in Table 2 (based on 1980 prices calculated for Lucknow, UP):

TABLE 2

(Diameter and depth
in meters)

Number of users	Pit inside premises		Pit outside premises	
	Diameter	Depth (effective)	Diameter	Depth (effective)
5	0.90	1.1	0.9	1.1
10	1.10	1.4	1.2	1.2
15	1.25	1.6	1.3	1.4

The economical pit sizes at any particular place would, however, depend upon the local rates for labor and materials.

Siting of pits

2.4.2 Ideally, the pits should be placed symmetrically at the back of the latrine pan, as shown in Drawings Nos. 5, 7 and 9; however, if site conditions do not permit this layout, the pits can be placed on the side or

even in front of the pan as shown in Drawings Nos. 11 and 12. However, more water may be necessary for flushing in such cases.

Location

2.4.3 The leach pits should be located within the house grounds. Efforts should be made to construct them in open spaces or the courtyard of the house; but, if this is not possible, the pit can be located on the verandah or even in a room. However, if it is not feasible to locate them within the premises, they may also be constructed under a footpath or under narrow lanes, and, in extreme cases, even under a road. The local authority will have to be approached for approval or plans for construction of pits under footpaths, lanes or roads, and an authorized representative of the authority should inspect the site to consider whether to recommend approval for such construction, and to satisfy himself that it is not technically possible to locate pits within the premises. The design adopted for leach pits under a footpath could also be used for lanes if vehicular traffic such as bullock carts, trucks, cars or tractors, is not likely to pass over the pits. It is necessary to differentiate between the three situations (within premises, under footpaths or narrow lanes, or under roads) as the pit design, and consequently the costs, will be different in each case.

Distance between two pits

2.4.4 The minimum space between the two pits should be equivalent to at least the effective depth of the pit. If the spacing between the two pits has to be reduced, an impervious barrier, such as a cut-off screen or puddle wall, should be provided between them.

Distance from existing structures

2.4.5.1 In many cases, the space available for constructing leach pits may be small, and placement of pits near existing structures may be unavoidable. The pit digging and subsequent seepage may disturb the soil surrounding the pits. The recommended minimum distance of the leach pits from foundations of existing buildings depends upon the soil characteristics, the depth as well as type of foundations of the building, and the depth of the leach pits. Safe distances in different types of soil and for various depths of leach pits for a two-storey building, as recommended by CBRI, are given in Table 3.

2.4.5.2 In cases where leach pits are quite close to existing building foundations, the openings in the honeycomb brick walls of the leach pits may be reduced from 12 to 15 mm. Experience shows that the leach pits could be located even 15 metres away from the latrine cubicle provided the connecting pipe is laid at a slope of 1:5:1 to 15.

TABLE 3

Type of soil	For pits within premises		For pits outside premises	
	Total depth of pit (metres)	Distance of pit from the existing structure (metres)	Total depth of pit (metres)	Distance of pit from the existing structure (metres)
Clayey sand	1.30	0.22	1.96	0.54
(Sand > 50%)	1.73	0.43	2.27	0.72
	2.05	0.60	2.56	0.88
Sandy clay	1.30	0.32	1.96	0.80
(Clay and	1.73	0.60	2.27	1.06
silt > 50%)	2.05	0.88	2.56	1.30

Depressions and water-logged areas

2.4.6 The pits should not be located in depressions where waste-water or rain water is likely to collect round and over the pits. Any depressions should be completely filled. If they are too big (as in the case of a pond), or if pits are to be constructed in water-logged areas or adjacent to ponds or tanks, the pit tops should be raised to 0.6 to 0.8 m above ground level, and earth fill placed up to a distance of 1.5 metres completely to the top, as shown in Drawing No. 15. The raising of a pit top may necessitate raising a latrine floor also.

Location in drainage line

2.4.7 The pits should not be located in either

- (a) the natural drainage paths (if one exists); or
- (b) the path of a stormwater drain.

Water pollution aspects

2.4.8 Proper information about and investigations of hydrogeological conditions of, sites where leach pits are to be located are prerequisites for the implementation of the program, so that pollution risks to groundwater and water distribution pipes are minimal. Extensive pollution studies done in India, the United States of America and elsewhere have confirmed that:

- (a) there is no risk of bacterial pollution in locating pour-flush latrines with leach pits in alluvial soils where a predominance of silt mixed with fine sand exists and where the pit bottom is at least 2 m above the maximum ground-water level, provided a safe separation gap is maintained between the pit and the source of drinking water;

- (b) even under unfavorable hydrogeological conditions such as coarse sand, high groundwater velocity and high water-table, and where the pit bottom is submerged or less than 2 m above the water-table, this system can be used provided suitable modifications are made to the pit and the latrine; and
- (c) If the drinking water sources and the water mains are in the same vicinity, the 'safe' distances given in paras. 2.4.9 and 2.4.10 should be complied with.
- (d) conditions such as rocks with fissures, chalk formations, old root channels, etc., demand very careful investigation and may need suitable modifications or even adoption of alternative systems (see para. 2.4.9.3 below).

Safe distance from drinking water sources

2.4.9.1 In dry pits or unsaturated soil conditions (i.e.) where the distance between the bottom of the pit and the maximum ground water level throughout the year is 2 m and more,

- (a) the pits can be located at a minimum distance of 3 m from drinking water sources such as tubewells and dugwells if the effective size (E.S.) of the soil is 0.2 mm or less; and
- (b) for coarser soils (with E.S. greater than 0.2 mm), the same safe distance can be maintained if the bottom of the pit is sealed off by an impervious material such as puddle clay or plastic sheet and a 500 mm thick envelope of fine sand of effective size of 0.2 mm is provided all round the pit.

2.4.9.2 In wet pit or saturated soil conditions (i.e.) where the distance between the bottom of the pit and the maximum ground water level during any part of the year is less than 2 m,

- (a) the pits can be located at a minimum distance of 10 m from drinking water sources such as tubewells and dugwells if the E.S. of the soil is 0.2 mm or less; and
- (b) for coarser soils (with E.S. more than 0.2 mm), a minimum distance of 10 m can be maintained if the pit is sealed off by an impervious material such as puddle clay or plastic sheet and a 500 mm thick envelope of fine sand or effective size of 0.2 mm is provided all round the pit.

2.4.9.3 The above cases are summarized in Table 4:

TABLE 4

Case	Distance between the bottom of the pit and the maximum ground water level	Effective Size of the formation soil	Minimum horizontal distance of separation	Modification needed
1.	≥ 2 m	<0.2 mm (fine sand, clay and silt)	3 m	None
2.	≥ 2 m	>0.2 mm (coarse sand)	3 m	Provide envelope of sand and impermeable pit bottom
3.	≤ 2 m	>0.2 mm (coarse sand)	10 m	Provide envelope of sand and impermeable pit bottom
4.	≤ 2 m	<0.2 mm (fine sand, clay and silt)	10 m	None

2.4.9.4 In both the cases of 2.4.9.1 (b) and 2.4.9.2 (b),

- (a) the sand envelope is to be taken up to at least 2 m above the possible maximum water level and its edges chamfered so that no water stagnates on the top of the sand filling.
- (b) where the bottom of the pit is submerged below the maximum ground water level:
 - (i) the top of the pits should be raised above the ground level, if necessary, so that the inlet pipe into the pit is at least 0.75 m above the maximum ground water level;
 - (ii) the sand envelope should be taken up to 0.3 m above the top of the inlet pipe and suitably confined to exclude any surface drainage including rain water directly entering the sand envelope;
 - (iii) in mound type latrines, 1 m high earthfilling should be provided for at least 0.25 m beyond the sand envelope with the edges chamfered to lead away the rain or surface water; and

- (iv) the honeycomb brickwork for the pit lining should be substituted by brickwork in cement mortar 1:6 with open vertical joints (i.e., without mortar).

2.4.9.5 For preparing the sand for envelop purposes as prescribed under 2.4.9.1 and 2.4.9.2, the following steps may be adopted:

- (a) Divide the stock sand into two equal portions - one portion sufficient for preparing the envelope.
- (b) From out of one portion, fill up a box of dimensions 1 m x 0.5 m x 0.5 m.
- (c) Sieve the entire sample from the box through a sieve of 0.2 mm size.
- (d) Transfer all the sand passing through into the same box, level and measure the depth (say, 'a' cm).
- (e) Percentage of the sand finer than 0.2 mm is given by 2a.
- (f) If the percentage lies between 8 and 12, use the stock sand straight away.
- (g) If the percentage is less than 8 (say 6), sieve enough of the sand from the second portion through a 0.2 mm sieve to produce a total quantity equal to the first portion; thoroughly mix and use this sand for the envelope.
- (h) If the percentage is more than 12 (say 15), sieve the first portion completely and discard from the fine sand an amount equal to the excess ($15 - 10 = 5\%$) of the total sand of the first portion and use the rest of the total first portion, thoroughly mix and use for the sand envelope.

2.4.10 Safe Distance from Water Supply Mains

2.4.10.1 Lateral distance between the leach pit and the water main should be at least 3 m provided the water table does not rise during any part of the year above the pit bottom and the inlet of pipe or drain to the leach pit is below the level of water main. If the water table rises above the bottom of the pit, the safe lateral distance should be kept as 8 m. If this cannot be achieved, the pipe should be completely encased to a length of at least 3 m on either side of the pit.

2.4.10.2 When the pits are located either under the foot path or under the road, or the water supply main is within a distance of 3 m from the pits, the invert of the inlet pipe should be kept at least 1 m below the ground level. This would ensure that the liquid level in the pits does not reach the level of the water main as the water mains are generally laid at 0.9 m depth.

2.4.10.3 The water pipe should not cut across the pit but where it is unavoidable, the water pipe should be completely encased for a length of 3 m on either side of the pit including the portion across the pit to prevent infiltration or exfiltration.

Viral Pollution

2.4.11 Very little work has been carried out on the travel of viral pollution of ground water with reference to on-site excreta disposal. But some laboratory studies on this aspect have indicated that the risk due to viral pollution is minimized if adequate interposing soil layer exists and the hydraulic loading is also limited to 50 mm/day.

Lining of Pits

2.5.1 The pit should be lined with honeycomb brickwork or stone in cement or lime mortar, or random stone masonry without any mortar. Alternatively, the pit can be lined with burnt clay rings or concrete rings. Under special circumstances, lining can be bitumen-coated bamboo matting, but the life of such lining is limited.

Brick or stone masonry lining

2.5.2.1. Brick linings should be constructed with bricks laid on edge for pits within premises, and with bricks laid flat for pits outside. Lining thicknesses will be approximately 75 mm and 115 mm respectively (depending on local brick dimensions). The thickness for stone masonry lining should be as minimal as possible, keeping structural and cost considerations in view.

2.5.2.2. In a brick lining the openings in alternate layers of bricks will generally be in one vertical line, and the width of opening will be 75 mm or less depending upon the soil characteristics. However, in cases where the foundation of the existing building is quite close to the leaching pit, the opening width may be reduced to 12-15 mm. This should also apply in situations where the soil contains a high percentage of sand. In stone masonry the vertical joints should be kept open, i.e., should not have mortar.

2.5.2.3. The lining above the invert level of the drain or pipe, up to top of the leaching pits, should be in solid masonry (i.e., no opening should be provided).

Use of rings for lining

2.5.3. If cement concrete rings are used they should have perforations, but the use of cement concrete rings may not be economical, and cement is not always easily obtained. In some places where burnt clay rings are manufactured locally for lining dug wells, the use of these rings for lining of leach pits located within premises may be economical. The clay rings should not be used in the pits located under a footpath or outside, because of heavy loads going over them. Well-burnt perforated clay rings, free from cracks, may be put on top of each other without joining them with mortar, up to the invert pipe level. Above this level solid brick or stone

masonry lining is required. The liquid from the pit will percolate and gases will be absorbed into the soil through the open joints and perforations in the rings.

Pit covers

2.6.1 For covering the pits, concrete domes, with or without reinforcement, reinforced concrete slabs, stone slabs or wooden planks of appropriate quality, can be used. Selection would depend upon anticipated load, cost, availability and site conditions. For pits located within the premises the assumed load should be the same as that for roofs of residential buildings, and for pits located under a footpath or road, covers may be designed for light and heavy traffic, respectively.

2.6.2. The designs for reinforced cement concrete (RCC) covers for 5, 10 and 15-user pits to be located within the premises and outside the premises under a footpath or road are given in Drawings Nos. 6, 8 and 10, respectively (Annex II).

Suitability of leach pits in black cotton soil

2.7. More than 200 units in individual households and 130 units in community latrines have been constructed in "black cotton"^{4/} and clayey soil. These are working satisfactorily, since the quantity of water used in a pour-flush latrine is so little that the black cotton soil poses no absorption problem.

Standard designs

2.8. Detailed drawings and cost estimates for the nine standard designs of pour-flush latrines, viz., for 5, 10 and 15-users and for pits within premises, under footpaths or roads, should be prepared for each typical location. This will facilitate expeditious and economical construction work. Typical designs for 5, 10 and 15-users appear in Drawings Nos. 5, 7 and 9.

Superstructure for latrine

2.9. The superstructure should be economical and affordable and should be consistent with the adjacent main building structure. Stones, fired bricks in mud mortar, or sun dried bricks in mud mortar, could be used in the superstructure. Details of foundation, plinth and superstructure appear in Drawings Nos. 3 and 4. A unit for the hut dwellers could be constructed of bamboo matting with mud plaster inside and out. Estimates for a typical design in brickwork, as well as the various components, may be seen in Annex III.

^{4/} Note that this description refers to a fine-grained soil in India which is not identical to the soil in Africa given the same name.

Community latrines

2.10.1. The evaluation study conducted by TAG reveals that, in view of the poor maintenance of the system, people generally prefer open air defecation to using community latrines. Therefore, unless a proper infrastructure for maintenance of community latrines is created, these should not be constructed.

2.10.2. Each seat should be designed to cater to the needs of 15 to 20 persons with adequate facilities for lighting, ventilation and proper supply and storage of water for flushing and ablutions. Twenty-four hour service for cleaning and maintenance should be ensured. Cost estimates for the community latrines have been provided in Annex III, and the designs are shown in Drawings Nos. 14, 15 and 16 (Annex II).

CHAPTER III

INSTITUTIONAL REQUIREMENTS

A Suitable Institution

3.1.1 For a successful on-site pour-flush latrine program, it is necessary to set up a suitable institution for planning, implementation and maintaining facilities oriented to the needs of the people.

3.1.2 Studies of ongoing latrine programs in various states, undertaken by TAG-India revealed that one of the main reasons for slow progress is the non-availability of a proper institution or agency for:

- (a) executing the program for a reasonable service charge, on behalf of a householder, from the time of application to the completion of the work, including the several stages of approval, withdrawal, and collection of funds from different sources;
- (b) observing all formalities, including documentation, selection of designs suitable for individual locations, approval of plans and estimates;
- (c) procurement of scarce materials;
- (d) arranging for skilled and non-skilled labor;
- e) arranging for the desludging and removal of pit contents when required;
- (f) recovery of loan instalments; and
- (g) promotional and educational activities.

If all these activities cannot be performed by a single institution, there should be some lead agency responsible for coordinating them.

3.1.3 For effective implementation of a large-scale latrine program in the Indian states, the following four institutional alternatives could be suggested:

- (a) local authorities;
- (b) establishment of an autonomous latrine board or corporation;
- (c) an existing Public Health Engineering Department, Municipal Engineering Department, or Board, dealing with water supply and sewerage; and
- (d) social organizations.

3.1.4 In addition to the above agencies, there should be a State Direction Committee to formulate policy and execute the program. At the district level there should be a District Implementation Committee chaired

by the District Magistrate concerned. This Committee will review progress of program implementation and resolve problems that may arise.

3.1.5 A Project Management Cell should be established in the office of the Director of Local Bodies/Director of Municipal Administration or the Chief Engineer, Public Health Engineering Department. This Cell will provide technical guidance; prepare standard designs, bills of quantities and estimates; arrange training; procure materials such as pans, traps, pipes, cement and any other scarce materials; and monitor overall program performance.

3.1.6 The latrine construction program could be executed through local authorities or a Public Health Engineering Department, or any other agency according to the policy of the State Government. If the program is executed through local authorities, their existing technical staff may need to be strengthened. Expenditure on any additional staff can be met out of supervision charges to be levied on construction of latrines. The agency responsible for implementing the program should also be responsible for preparing a detailed work program, for organizing training of local contractors, masons and technical staff of the agency, for receipts and disbursements of loan and grant funds, and for execution of work. The local authority concerned will, however, retain responsibility for recovery of loans from the beneficiaries, operation and maintenance of public latrines, attending to complaints of latrine adopters and providing pit emptying service to individual householders.

Orientation and training

3.2 Orientation courses, probably of two days' duration, should be arranged by the implementing authority for Chairmen, municipal members, municipal officers and others concerned with the program. The implementing authority or the State Direction Committee should arrange training courses for Assistant Engineers, Junior Engineers, Sanitary Inspectors, and Supervisors and Contractors; these courses will probably last one week. These technical staff will, in turn, train the local masons.

Methodology for construction of household latrines

3.3 Whatever the organizational pattern of the agency entrusted with the program, the actual installation of latrines would best be carried out through small and medium contractors in the town, who will also be the best motivators for the program, as they will earn their livelihood from it. However, they should be trained. The procedure should be that all the work which a householder is normally required to do from time of the application to the completion of the latrine should be done through one agency; at the same time, the householder should be involved to the maximum possible extent (latrine siting, design selection, and unit construction). Each licensed contractor or plumber may be asked to deposit security money to ensure satisfactory performance. The unit costs should be fixed at the beginning of each financial year by the implementing agency based on a Public Works Department (PWD) or Public Health Engineering Department (PHED) schedule of rates in consultation with the Project Management Cell.

Communication support: publicity, promotion and health education

3.4.1 Promotional activities will be needed to ensure that program objectives are achieved. Information and education for those who receive improved latrines will ensure maximum life-span and impact on health and environment. The contractors, municipal engineers, sanitary inspectors and supervisors should educate potential clients about the program, using hand bills (Form No. 1, Annex IV) provided by the implementing agency. The implementing agency should support these efforts through, for example, advertisements in newspapers, posters on hoardings, and slides shown in cinemas. This support should be intensified during the initial phase of the program or when the rate of acceptance slows down. As the program moves towards groups with less interest in having household latrines, promotional activities should be stepped up. For this a special construction campaign may also be launched.

3.4.2. After each latrine is completed, the contractor responsible should advise the household on its use, care and maintenance. The Municipal Engineer (or the Engineer responsible for construction), Sanitary Inspector, or Supervisor, should repeat these instructions when the work is checked and approved, and should leave with the household a leaflet on use and maintenance (see Chapter VI). Thereafter, staff of the municipality concerned should visit households of latrine adopters from time to time to repeat these instructions, if necessary, in order to encourage good hygienic habits.

3.4.3. Public latrines should be provided with posters on proper latrine use and hygiene.

Procedure for getting a latrine constructed

3.5. Once the houseowner expresses his interest in having a latrine, either to the local authority or to the licensed contractor, the following procedure should be adopted (draft forms for completing these formalities are given in Annex VI):

- (a) The householder should be given an application form (Form No. 2 or 3 as the case may be), which should be returned by him, duly signed, to the licensed contractor, the municipal staff or the implementing agency. The licensed contractor should visit the site and assess the availability of space for latrine and leach pits, enquire about the number of users and decide, in consultation with the householder, the appropriate standard design, taking into consideration additional factors such as: location of water supply sources, soil characteristics, sub-soil water level, and structural condition of the house. A sketch plan showing the layout of the proposed installation should be prepared for submission to the local authority or implementing agency. If some work additional to the standard design and drawing is involved, the details and cost should be calculated.
- (b) The municipal engineer, or the technical authority of the implementing agency, should submit his report (see Form No. 4) to Executive Officer, keeping in view for his approval all

considerations mentioned above. If necessary he, or his authorized representative, should inspect the site, particularly if the pits cannot be located within the premises, before the necessary certificate is issued on Form No. 5.

- (c) The householder should be notified of the approval and be asked to deposit the cost of additional works, if any, which are not covered in the cost of the approved latrine design to be constructed (See Form No. 6). A copy sketch showing the layout plan and three copies of the agreement (see Form No. 7) should be sent to him.
- (d) On receipt of the agreement, the houseowner should deposit the cost of additional works in the office of the local authority in advance, and return the agreement forms duly signed.
- (e) After the agreement forms are checked and found to be in order, the contractor should be permitted by the implementing agency to go ahead with the construction, and the houseowner should be provided by the implementing agency with details of the latrine to be constructed, including a list of materials needed, specifications and key dimensions and also a copy of the standard drawing (see Form No. 8).
- (f) The contractor should collect the pan, trap, cement and pit covers (pit covers should be cast in a central location by the implementing agency) from the local authority or the technical representative of the implementing agency, and complete the work.
- (g) The contractor should obtain the satisfactory completion certificate from the householder (Form No. 9) and submit it in duplicate to the implementing agency for payment, while keeping a copy himself. He should explain to the householder the use and maintenance of the latrine. A pamphlet (Form No. 10) containing the instructions will be supplied by the local authority or the implementing agency.
- (h) The completed installation should be inspected by the technical representative of the implementing agency and, after the work has been approved, payment should be made to the contractor, and a (Form No. 11) should be issued to the houseowner, guaranteeing that the implementing agency will be responsible for rectifying any constructional defect within a year of the latrine being built.
- (i) Details of the house and of the latrine construction, etc., should be recorded in the office of the local authority for recovery of the loan. The loan recovery from the houseowner should commence from the month following completion.

Supervision charges

3.6. Supervision charges as approved by the State Government or laid down in the sanctioned project should be added to the actual cost of a latrine based on standard designs and drawings. Thus, for the householders, the cost of a latrine will be inclusive of supervision charges. These supervision charges on latrine construction should cover all administrative and engineering expenses, the cost of additional staff, forms, publicity, education, motivation, training and provision of free service to latrine adopters, etc., incurred by the implementing agency, local authority, the Government and other agencies engaged in the execution of the project. The amount of supervision charges should be shared proportionately among the agencies in accordance with the tasks they perform when implementing the latrine program.

Legal amendments

3.7.1. In order to give legal support to the program, the existing acts, rules, regulations, by-laws and Rent Control Acts of local authorities may need amendment. In the Master Plan and Feasibility Reports, the following amendments, where necessary, have been suggested. These points need immediate attention for smooth and expeditious implementation of the latrine program:

- (a) In future no one should be allowed to construct a dry/bucket or other type of service latrine. If a house is constructed, reconstructed or additions and alteration are made, it should be obligatory for the owner to construct a water-flush latrine. Such bylaws do exist in most of the states, but there is no follow-up to see whether the owner has constructed the latrine in accordance with an approved plan. The local authority should check and, in case of default, it should have the power to take suitable action against the owner.
- (b) Open air defecation should be legally prohibited in public streets, public places and in any open space - public or private - extending even to areas outside the municipal limits up to a specified radius.
- (c) Most of the present regulations specify only septic tank latrines or latrines connected to sewers in the water-flush category. Pour-flush waterseal latrines with leach pits should be a specific part of this category.
- (d) Letting or renting of any house, or part of a house, for residential purposes should be made illegal unless the tenant and his family members have been provided with at least a pour-flush waterseal latrine, whether exclusive or shared.
- (e) Local authorities should be empowered to give notice to the owner of the house or the tenant that within a prescribed time a dry bucket latrine should be converted into water-flush unit or a new water-flush latrine constructed, if feasible, in households where

no latrine exists. If this is not done, the municipal authorities may convert or construct the latrine, as the case may be, and recover the cost from the owner.

- (f) In most of the States, the tenant cannot have a latrine constructed in his premises or get a dry bucket latrine converted into a water-flush unit if the houseowner does not give his approval. The tenant should be given the right to have a dry bucket latrine converted or a new water-flush latrine constructed within his premises even if the owner is not agreeable to it.
- (g) The Rent Control Laws should be amended to empower the house-owner to raise the rent of the premises thereby allowing him a return on the expenses incurred by him on conversion or construction of water-flush latrine.
- (h) The local authorities should be empowered to give permission for construction of leaching pits under the public road, street or footpath, provided it is not feasible to locate them within the premises of the household where a pour-flush latrine is to be constructed.
- (i) The local authorities should be empowered to recover the loan amounts for conversion or construction of latrines from the beneficiaries through distraintment such as arrears in taxes or land revenue.

3.7.2 Model by-laws for regulating the construction, operation, maintenance and control of latrines to be adopted by the local authorities are shown in Annex V.

CHAPTER IV

MOBILIZATION OF FINANCIAL RESOURCES

4.1 Keeping in view the financial resources available for implementing a large scale low-cost pour-flush latrine program, priority should be given to the conversion of all dry latrines into waterseal ones, as this will reduce both social and health problems. Houses without latrines could be dealt with later.

Financing pattern

4.2.1 Past experience of the implementation of pour-flush latrine program in India reveals that in poor families sanitation carries a lower priority than water supply. Therefore, if the program is aimed to serve the poorest of the poor, a liberal subsidy would have to be provided for them. At the same time, those who can afford to pay for the cost of the unit should pay the full cost. Therefore, determination of whether the beneficiaries can or cannot afford a unit is very important for such a program. There could be three approaches to determine whether a household can afford a latrine: (a) income tax liability; (b) assessed value of the property; and (c) public utilities available in the house.

4.2.2 It would be difficult to assess the income level of beneficiaries in view of the fact that the majority of the population in small and medium towns is non-salaried, and so income tax liability and household income cannot be assessed correctly. It is also difficult to rely on the second criterion, as the houses are not assessed at proper intervals and they may also be over- or under-assessed. Thus, the only alternative left to assess whether a householder can afford a unit is the availability of the public utilities (water connection, electricity connection, and existing dry latrines) in the premises. These would be the economic indicators of the household. Therefore, the grant and loan to an individual household could be based on the number of public utilities a particular household enjoys. Although it is difficult to arrive at a very just and correct rationale for grant and loan components, the following have been suggested for consideration: households having at least two out of three utilities (water and electricity connections and bucket latrines): 100% loan; households having one of the utilities: 50% loan and 50% grant; households with no utilities within the premises: 25% loan and 75% grant. A small loan component even in the poorest category is considered necessary for ensuring involvement and participation of beneficiaries.

4.2.3. The Indian experience shows that, even if a household has all the public utilities, payment of the entire cost of a pour-flush latrine unit in one amount cannot be afforded by the majority of people. The evaluation studies have revealed that if long-term soft loans are made available there would be wider acceptance of the program. Monthly instalments to repay the loan for construction of a latrine should be approximately 1.5% of the monthly income of the household.

4.2.4 Funds for the latrine program will be made available to local authorities, or the Public Health Engineering Department, or any organization as the State Government considers fit. In some states part of the finances may also have to be arranged by the local authorities from their own resources. The financing pattern (proportion of grant, loan and beneficiaries' contribution) and loan repayment terms and conditions should be prescribed by the State Governments.

Disbursement of funds

4.3.1 No funds should be provided for the construction of pour-flush or water-flushed latrines with septic tanks. If a householder wants to construct and pay for one himself permission can be given by the local authority, provided, before construction, approval of the design and drawing of the proposed latrine has been obtained. For a pour-flush latrine, however, the construction has to be carried out by a licensed contractor. No financial assistance should be provided to those who are building a new house, or making additions and alterations to a house.

4.3.2 The amount of loan and grant portions should be determined on the basis of total cost (including supervision charges), and a financing pattern approved by the State Government.

4.3.3 If some additional works over the standard design and drawing are necessary, due to site conditions or other reasons, details of additional works and costs should be worked out by the local authority or the implementing agency, and the householder/houseowner should be asked to deposit this amount with the local authority/implementing agency in advance, as stated in paragraph 3.5 (c). Upon completion of the unit, the implementing agency will pay the contractor the costs of additional work as well as cost of the latrine based on the standard design and drawing.

4.3.4 Those people who can afford to pay the total cost from their own resources for the loan component in one amount should be encouraged to do so by the local authority. This would accelerate implementation and also reduce the total financial burden. However, the procedure set forth for approval of the site plan and design by the local authority, and for works to be executed only by a licensed contractor, should be adhered to. In this case the owner will, however, make payment direct to the contractor at the agreed rates.

Recovery of loans

4.4 Monthly instalments for recovery of loan amounts from beneficiaries should be allocated for each type of standard design on the basis of terms and conditions laid down by the Government. The local authorities will recover loans from beneficiaries as part of the existing revenue collection system, i.e., together with house tax, water tax and other levies collected at enumerated intervals. Before construction of a latrine, an agreement for loan repayment should be executed by the householder/houseowner. This should cover the following points:

- (a) Total cost of the latrine (including cost of additional works, if any), supervision charges; grant, loan and cash contributions, if any, should be indicated.

- (b) Terms and conditions for the loan repayment, i.e., rate of interest, period and mode of repayment, either monthly, bi-monthly, tri- or six-monthly should be mentioned.
- (c) The agreement should make clear that no cash will be given to beneficiaries but the facility will be provided in the household. The houseowner will, however, authorize the implementing agency to pay the contractor for the work done.
- (d) The loan instalments will be paid regularly, but in case of default:
 - (i) the rate of interest (from the date of the last loan instalment paid to the date of payment of outstanding loan) will be increased by 50%.
 - (ii) recovery with penal rate of interest could be effected in the same way as tax arrears are recovered; and
 - (iii) the water connection, if the defaulter has one in his house, will be disconnected.
- (e) The implementing agency will take responsibility for rectifying any constructional defect which may be apparent within a year of construction.
- (f) The local authority will provide pit emptying services free of cost when requested; the pit contents will then be the property of the local authority.
- (g) The loan recovery will start the month following the latrine completion and will continue until the full amount is recovered with interest. Completion of the latrine will date from submission of the completion certificate by the houseowner.

A typical loan agreement has been provided in Annex IV (Form No. 7).

Repayment by the local authority to the lender

4.5 The local authority will be responsible for payment of the loan to the lender on the terms and conditions laid down by the lender at the time of giving the loan, whether the local authority has been able to recover the loan instalments from the latrine adopters or not.

CHAPTER V
CONSTRUCTION

Materials

Materials to be supplied by the implementing agency

5.1.1 The implementing agency should keep in stock an adequate number of squatting pans, traps, pipes, footrests, cement and pre-cast slabs for covering the leach pits and junction chambers to ensure that the work in progress is not held up. The supply of these components should be arranged through the Project Management Cell, or any other agency set up by the State Government. However, if there is no central agency for procurement, local authorities can invite bids by tender for supplying materials. Cement can be arranged through the District Magistrate/Collector or the Director of Local Bodies/Municipal Administration. Reinforced concrete cement (RCC) covers for leaching pits and junction chambers should be cast in one central location by the implementing agency in order to retain control over quality and workmanship.

Materials to be arranged by the contractor

5.1.2 The contractor will be responsible for supplying bricks, sand, brick ballast and stone grit of specified quality.

Slabs for Covering pits and junction chambers

5.2.1 RCC or stone slabs, or timber planks, depending upon the site conditions and cost, can be used for covering the pits and junction chambers.

Casting of RCC slabs and domes

5.2.2 Steel, cement, coarse sand and stone grit 6 mm to 20 mm gauge (graded) should be obtained. For casting slabs, a flat platform of bricks or similar material should be built on well-consolidated ground. A water tank of suitable size for curing slabs should be constructed.

5.2.3 Steel should be free of rust and cut to size and shape. Hooks should be provided at both ends and, if separate pieces are used, proper overlap (48 times the diameter of rod) should be provided. The reinforcement as shown in Drawings Nos. 6, 8 and 10 should be tied with mild steel wire. While casting the slab, a clear cover of 12 mm should be provided for the reinforcement rods, i.e., reinforcement rods should be kept 12 mm above the platform. A mixer should be used where possible for mixing sand, cement and stone grit. However, if a mixer is not available, hand mixing may be done, provided that 10% extra cement is added. Sand and cement should first be mixed thoroughly dry before adding stone grit. The quantity of water used in the concrete mix should be just sufficient to produce a dense concrete of adequate workability.

5.2.4 At the time of casting, proper vibration of concrete should take place to avoid honeycombing. No plaster should be put over the concrete. The top surface should be finished even and smooth with a wooden trowel and rendered smooth with neat cement. Curing with moist gunny bags or wet sand may be started after the concrete has begun to harden, i.e., about one to two hours after casting. Then, after 24 hours, the concrete surface should be submerged in water, minimum 25 mm depth. Four days after casting, the slabs should be put gently in a tank full of water to cure for 10 days.

5.2.5 The size of the slab should be such that it may have a minimum bearing of 80 mm on walls on all sides. For easy handling, the slabs can be cast in two or three pieces. After placing the slabs over the pits, they may be joined with 1:6 cement sand mortar or hot bitumen.

5.2.6 For leach pits under a road or footpath an RCC dome should be cast in a central place by the implementing agency.

Stone slabs

5.2.7 The thickness of the stone slab should be 50 mm for up to one metre span, and 65 to 75 mm thick up to 2 metres span. The stone slabs should be joined with 1:6 cement : sand mortar after placing them over the pits.

5.2.8 RCC or stone slabs should be used for covering the junction chambers.

Fixing of pan, trap and footrests

5.3 The squatting pan and trap should be fixed so that the trap has a 20 mm waterseal. As far as possible the squatting pan should be horizontal and flush with the floor, and the rear side of the pan should be at least 200 mm away from the wall. The squatting pan should be fixed over well-consolidated earth with 50 mm thick brick ballast padding with a 20 mm thick layer of sand underneath the pan. The trap should be placed over brick as shown in Drawings Nos. 5, 7 and 9. The pan and trap should be joined with spun yarn soaked in neat cement and then caulked with 1:1 cement mortar. The joint should be perfectly watertight. Footrests should be fixed as indicated in Drawing No. 1 while laying the floor, with their tops about 20 mm above floor level. The floor should be smooth, impervious and durable, with a 3% slope towards the pan all around.

Connection to pits

5.4.1 The trap can be connected to the leach pits through a drain or a pipe. Leach pits located within the premises may be connected by a covered drain as shown in Drawing No. 5. In such cases no junction chamber will be needed. Pits located under a foot path or road should be connected by pipes through a junction chamber as indicated in Drawings Nos. 7 and 9.

Drain

5.4.2 A brick drain as shown in Drawing No. 2 should be constructed at a slope of 1 in 5 to 1 in 15. The base concrete should be laid in cement concrete 1:6:12 (1 cement:6 sand:12 brick ballast of 40 mm gauge graded) or lime concrete 1:3:6 (1 white lime:3 soorkhi;^{5/} 6 brick ballast) and over it 25 mm thick cement concrete 1:2:4 (1 cement:2 coarse sand:stone grit 6 to 10 mm gauge) should be laid in a channel shape as shown in the drawing. The drain sides should be constructed in 1:6 cement : sand mortar. Curing should take at least a week. The branch to one of the pits at the bifurcation point should be blocked off, and covered by flat bricks jointed in mud mortar.

Pipe

5.4.3 Non-pressure AC pipe of 75 mm. dia. may be used. It should be laid at a slope of 1 in 5 to 1 in 15. The jointing of the pipes should be done in 1:1 cement:sand mortar. The joints should be made watertight.

Junction Chamber

5.4.4 A 250 x 250 junction chamber (Drawing No. 2) should be constructed at the bifurcation point of pipes. The base concrete, in 1:6:12 cement concrete or 1:3:6 lime concrete, should be 75 mm thick. Walls should be 115 mm thick-brickwork in 1:6 cement:sand mortar or 1:3 (1 white lime:3 soorkhi) lime mortar. Pipes should be embedded in masonry. At the bottom of the chamber, 250 mm thick 1:2:4 cement concrete should be laid sloping towards the pits; the inner sides of the chamber should be plastered in 1:4 cement:sand mortar. The bottom should be rendered smooth with neat cement with sides rounded off. It should be cured for a week. After curing, the mouth of one of the two pipes joining the pits may be blocked with flat brick in weak cement mortar and a precast RCC or stone slab cover (325 mm x 325 mm x 40 mm) may be placed over the chamber.

Lining of leach pits

5.5.1 Leach pits should be lined either with brickwork, stone masonry, dry stone pitching or burnt clay rings, bearing in mind cost and local availability of materials.

Brick work

5.5.2 Pits within premises will have honeycomb brickwork lining of 75 mm thickness. For the foundation, a layer of brick, 225 mm wide, should be laid, jointed with 1:6 cement:sand mortar or 1:3 lime mortar. Over this, 75 mm thick honeycomb brickwork should be provided to the bottom of the drain or pipe in 1:6 cement:sand mortar or 1:3 lime mortar. The openings in the brick lining should be of 115 mm x 75 mm size, in case of

^{5/} Soorkhi: a low-grade mortar used in India for masonry work: lime, cement, crushed brick, etc.

9" x 4 1/2" x 3" size bricks, and of 125 mm x 75 mm size in case of brick size 10" x 5" x 3". Where the leach pits are very close to the foundation of the existing building, the width of the opening may be reduced to 12 to 15 mm. For sandy soils the width of the opening should be reduced. The thickness of brick lining for the pits under roads or footpaths should be 115 mm. Over the invert level of a pipe or drain, solid brick work 75 mm and 115 mm thick should be provided (see Drawings Nos. 5 and 7) in pits within premises and outside respectively. The thickness of the solid brickwork in the shaft under the road should be 115 mm in 1:4 cement mortar (see Drawing No. 9).

Stone masonry

5.5.3 Lining can also be done in random rubble stone masonry. The stones should be dressed on the face, also on the sides and beds to such an extent that stones come into close proximity. Faces should be approximately of rectangular shape and all face joints should be hammer dressed at right angles to the face for a distance of 40 mm. Sharp and irregular projections on the stone face should be smoothed off. Thickness of lining should be fixed after working out the design and cost; however, the thickness should not be less than 150 mm. The mortar used for random rubble masonry work should be 1:6 cement:sand mortar or 1:3 lime mortar. No mortar should be used in vertical joints.

Stone pitching

5.5.4 The stones used should have weak corners and edges smoothed off and be dressed on the face, sides and beds to enable them to be laid closely together. One layer at the bottom and the portion above the invert level of pipe or drain should be in random rubble (RR) stone masonry in cement mortar 1:6 or lime mortar 1:3. The portion between these two layers of RR stone masonry should be dry stone pitched. Thickness of pitching and masonry should be determined after working out the design and cost, but it should not be less than 250 mm.

5.5.5 In pits under a footpath or road, stone pitching lining should not be used.

Burnt clay rings

5.5.6. Clay rings should be used in pits only in open spaces and courtyards within the premises, not under a footpath or main road. Burnt clay rings used for lining should have uniform deep cherry red or copper color and should be properly burnt. They may be cast with weep holes. Cracked or damaged rings should not be used. Rings should be stacked one over the other keeping the socket upward and placing the next ring in the socket of the lower one. The joints should remain open, i.e., no mortar should be used to join them. Rings should be raised up to the bottom of the pipe or drain. Above this 115 mm thick solid brick wall, 1:6 cement mortar should be provided up to the level where the cover is to be placed.

Curing

5.6 Curing of all cement or lime masonry work should take at least 10 days. In the case of lime masonry, curing should commence two days after it is laid.

Flooring

5.7.1 1:6:12 concrete (using graded brick ballast of 40 mm gauge) 75 mm thick should be laid for the subgrade. It should be well compacted at a slope of 3 in 100 towards the pan. The floor over the sub-grade should be laid in two layers, the lower layer being 22 mm thick and the upper 3 mm thick. The lower layer should be in 1:2:4 cement concrete, and the upper layer should consist of mortar comprising four parts of cement and one part of marble dust or coarse sand.

5.7.2 In hand mixing, cement and sand in the prescribed proportion should be thoroughly mixed and then added to the prescribed quantity of stone ballast and mixed again. After this, enough water should be added slowly to make a mixture of plastic consistency. The concrete should then be laid and trowelled over to give a 22 mm layer. The surface of the floor should be left for some time until all moisture disappears. The mortar for the top layer should be prepared by adding water to form a thick slurry, which should be laid and finished with a wooden or steel float. Curing should start the next day and continue for at least seven days.

5.7.3 Sub-grade for flooring can be laid in lime concrete as specified below:

- (a) 9 m³ of 25 gauge brick ballast to 4.5 m³ of white lime; or
- (b) 9 m³ of 25 gauge brick ballast to 1.6 m³ of white lime and 3.20m³ of brick powder (soorkhi).

Site clearance

5.8. Surplus materials and earth should be removed and the site cleared immediately after completion of work.

Specifications

5.9. All works such as masonry, flooring, drain construction and RCC should be done to Public Works Department specifications. First-class bricks should be used on all the work.

Supervision

5.10. The technical person in charge should give the layout to the contractor in consultation with the house owner, keeping in view the points referred to in Chapter II. After construction is completed, he should inspect and check the entire work carried out by the contractor. In particular, he should check compliance with the following:

- The work has been carried out according to the design given.
- The drain or the pipes have been properly laid.
- Size of leaching pits is in accordance with the standard design.
- The size of openings in the lining of pits is as specified.
- One drain or pipe has been blocked, so that the discharge from the squatting pan goes to one pit only.
- The latrine floor has been constructed and finished as specified.
- There is no blockage of the squatting pan and trap due to falling mortar during construction.
- The squatting pan, trap and footrests have been fixed correctly.
- The site has been cleared.
- The entire work has been done by the contractor in a workmanlike manner and neatly finished, and the houseowner is satisfied with the work.

CHAPTER VI

OPERATION AND MAINTENANCE

Maintenance of household latrines

6.1.1 Maintenance of a household pour-flush latrine is very simple. Day-to-day maintenance consists only of washing the latrine floor and cleaning the squatting pan. The squatting pan should be cleaned daily with a broom or a brush with a long handle after sprinkling a small quantity of detergent powder. This can be done by the householder, or he can arrange to have it done. The minimum amount of water should be used when cleaning the floor, as otherwise it will reduce the life of the leach pits.

6.1.2 In the latrine a container of 1.5 to 2 litres capacity should be kept filled with water. The squatting position should be such that excreta fall as near the center of the trap opening as possible. Before each use the surface of the squatting pan should be slightly moistened with water so that the excreta slide smoothly without sticking to the surface.

6.1.3 Wastewater from the bath or the kitchen, etc., or rain water should not be allowed to enter the leach pits or the squatting pan. To avoid choking of the squatting pan or trap, no other waste, such as kitchen waste, sweepings, rags, cotton pieces, etc., should be thrown in the squatting pan. However, if somehow the squatting pan or the trap should get choked, it can be rodded from the pan side as well as from the trap side. A split bamboo rod can be used for this purpose. If the choking cannot be removed, assistance should be sought from the local authority.

6.1.4. Only one of the two pits is to be used at a time. After about three years when the first leach pit is full (the indication being back flow when flushed), the discharge from the pan should be diverted to the second pit and the first pit should be allowed to rest. The diversion of discharge to the second pit can be undertaken by the householder or, if he wishes, he can make private arrangements for this to be done. After the pit is filled and the latrine is connected to the second pit, the pit cover should be removed and soil to a depth of 150 mm should be used to fill the first pit and the cover placed in position again. Where earth is not easily available, or there is difficulty in removal of the pit cover, the earth could be added later when emptying the pit contents, for ease of handling. When the first pit has been out of use for about two years, it can be emptied by the householder himself or by the local authority. This can be done manually by shovel or auger. The contents will then be safe for handling, dry and without any foul smell. In special cases such as flooded areas, etc., the sludge, after being taken out, should be spread out in a bed for sun drying during the non-rainy season and utilized as manure. It will be valuable humus with some fertilizer value. The humus can be utilized as manure in the kitchen garden or fields. When the second pit is full, the first pit should be used by diverting the discharge from second to first pit. Thus, one of the two pits is to be used alternately. The householder should keep a record when each of the two pits is put to use, disconnected and emptied; a card supplied by the local authority should be used for this purpose.

6.1.5. The local authority should provide emptying services to the householders free of cost on request through local contractors or through its own employees. The humus will become the property of the local authority. Marketing facilities should be developed for the sale and use of the humus as manure in the fields. It can fetch as much as Rs.45 per cubic metre and the local authority will be able to make some profit from the pit emptying process.

6.1.6. To foster confidence in the minds of the people about the suitability and performance of the pour-flush latrines, the local authority should provide free service to latrine adopters, and attend to their complaints regarding construction, operation and maintenance. Groups (each one consisting of a skilled and trained person, and a laborer, for about 2,000 latrines) should be maintained for this purpose. In small towns where the number of latrines is less than 1,500, only a trained laborer could be kept to work under the guidance of a technical employee of the local authority. However, in the beginning when the number of latrines is less than a thousand, the Junior Engineer or the Supervisor should attend to complaints.

Operation and maintenance of public latrines

6.2.1. The local authority will have the responsibility of operating and maintaining public latrines. Maintenance can be done by the local authority or can be contracted out.

6.2.2. Proper arrangements for lighting and water should be made at each latrine block. Attendants to keep the latrines clean should be on shift duty at each block for 24 hours, or at least for the period of use.

6.2.3. No charge should be levied for the use of public latrines by the permanent population. However, on latrine blocks located near bus stands, railway stations, market places, courts, hospitals, etc., where casual users (commuters) are expected to use them in large numbers, a charge of, say, Rs. 0.25 per head per use may be levied, or whatever the local authority decides. When the number of casual users increases and it becomes economically viable, separate attendants may be kept for this purpose. As an alternative, the public latrines allowed to be used "on a pay and use" basis may be contracted out on payment of a fixed amount to the local authority. The contractor will be responsible for the operation and maintenance of these public latrines, under the supervision of the local authority, and will retain the charges from the users.

Studies Conducted**Applied Investigation**

Evaluation of on-going pour-flush latrine programs in the States of Bihar, Gujarat and Tamilnadu.

Potential groundwater pollution by on-site leaching pit latrines.

Evaluation of public latrines in Bihar.

Organization, managerial, financial capability and legal authorities of the local Government of 110 project towns.

Scavengers' rehabilitation study.

Technology optimization of pour-flush latrines.

110 towns house-to-house survey

Collaborating Institution

University of Patna, Bihar; Sardar Patel University, Vallabh Vidyanagar, Gujarat; and Public Health Institute, Poonamallee, Madras, Tamil Nadu.

State Water Pollution Prevention Boards and Consultants.

ANS Institute of Social Studies, Patna, Bihar.

Rajasthan Institute of Local Self Government, Jaipur, Rajasthan.

University of Rajasthan, Jaipur, Rajasthan.

Central Building Research Institute, Roorkee, Uttar Pradesh.

Municipal Authorities and Consultants.

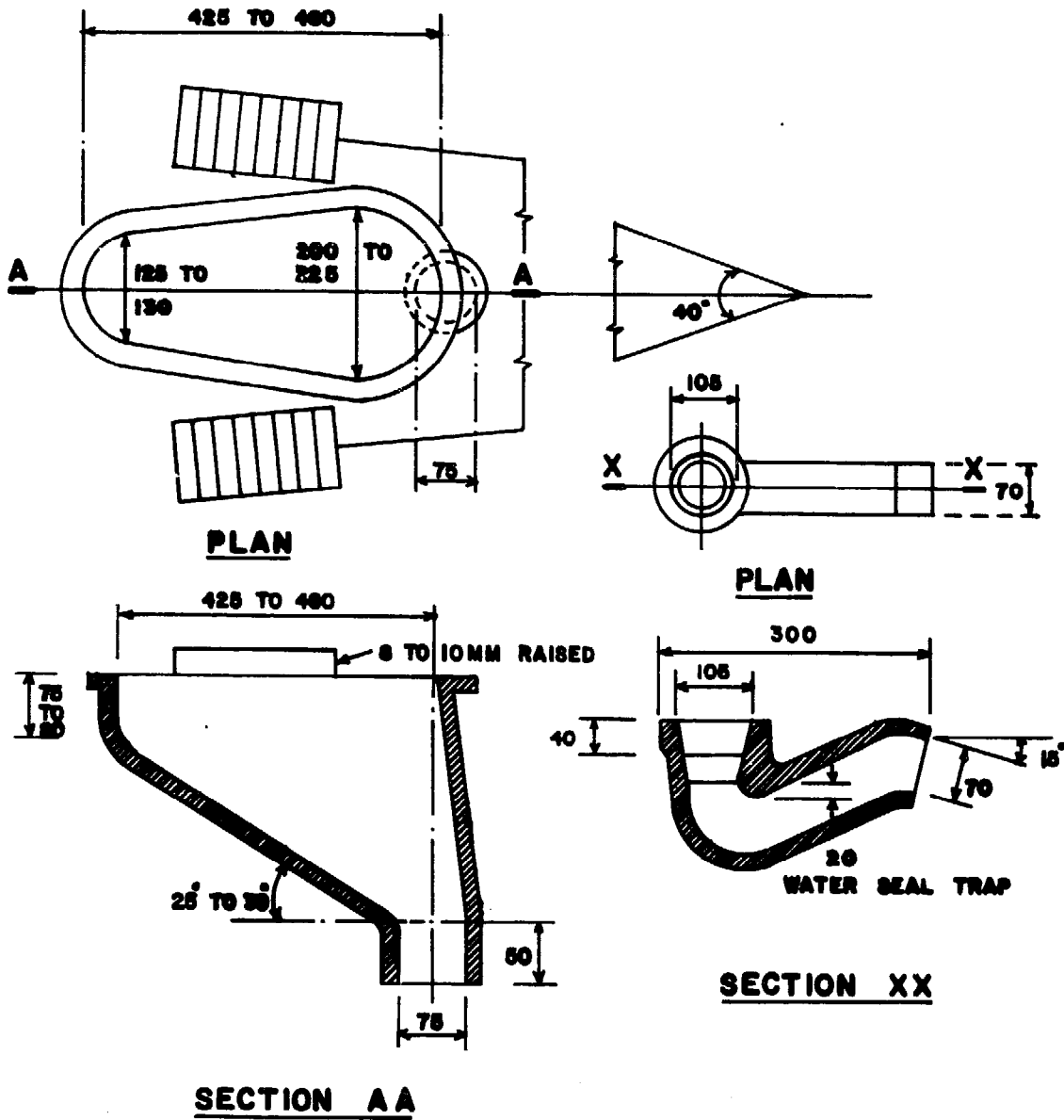

ALL DIMENSIONS IN MM

SCALE:- 1:300

UNDP INTERREGIONAL PROJECT
INT/81/047
DEVELOPMENT AND IMPLEMENTATION
OF LOW COST SANITATION INVESTMENT
PROJECT

DETAILS OF PAN AND TRAP

DRG. NO.

1

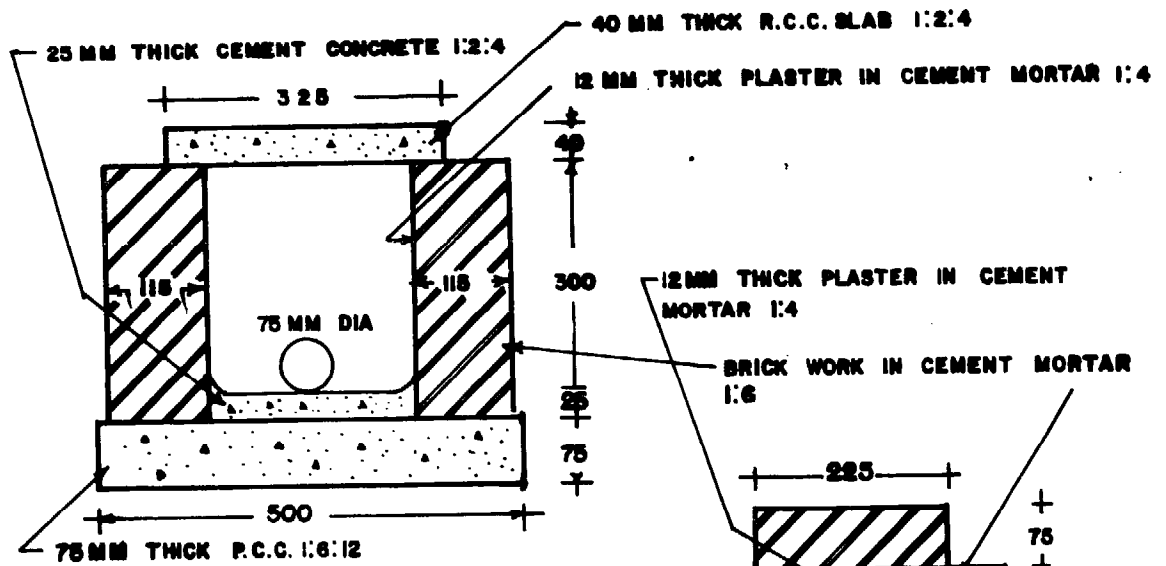

SECTION ON A B

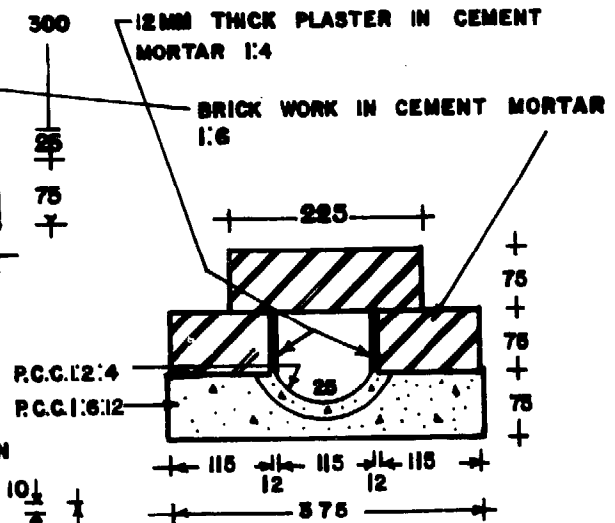

DETAIL OF BRICK DRAIN

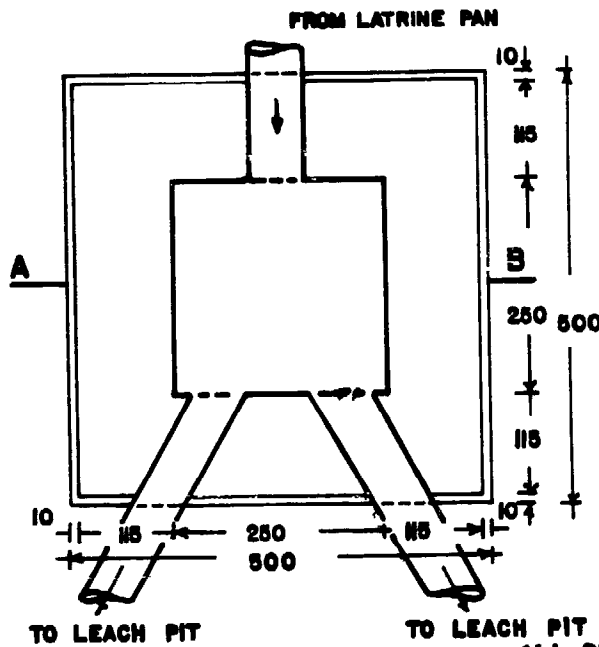

PLAN

ALL DIMENSIONS IN MM

SCALE-1:300

UNDP INTERREGIONAL PROJECT
INT/81/047
DEVELOPMENT AND IMPLEMENTATION
OF LOW COST SANITATION INVESTMENT
PROJECT

DETAILS OF DRAIN AND
JUNCTION CHAMBER

DRG. NO.

2

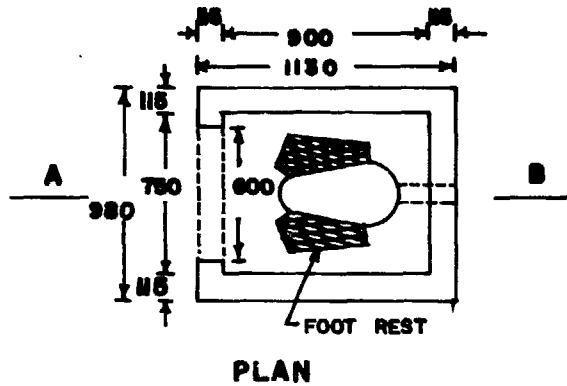

25 MM CEMENT CONCRETE 1:2:4 FLOORING
OVER 75 MM THICK C.C. 1:6:12

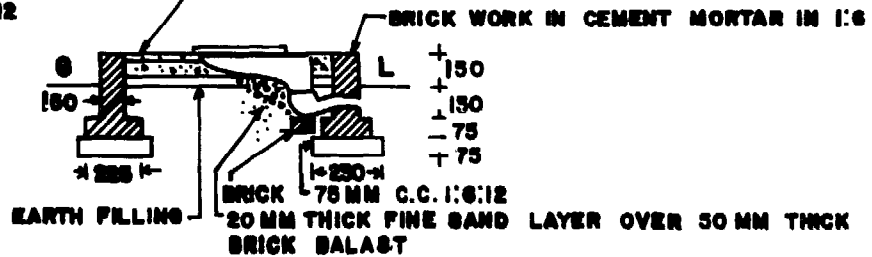

ALL DIMENSIONS IN MM

SCALE:- 1:300

<p>UNDP INTERREGIONAL PROJECT INT/81/047 DEVELOPMENT AND IMPLEMENTATION OF LOW COST SANITATION INVESTMENT PROJECT</p>	
<p>DETAIL OF FOUNDATION AND OF SUPER STRUCTURE OF</p>	<p>DWG. NO. 3</p>

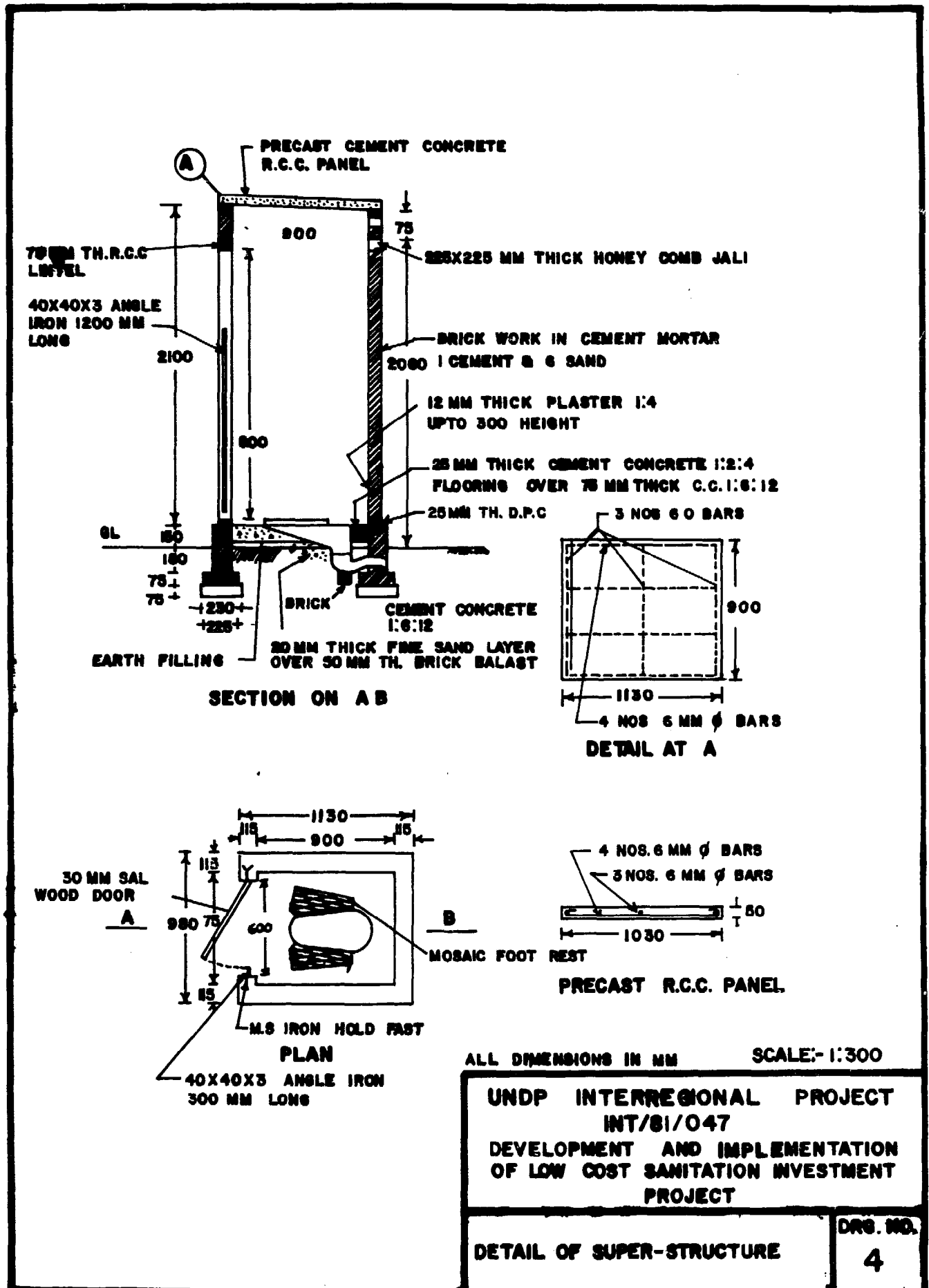

ADDITION TO DRAWING NO.5

USERS	NO OF SOLID BRICK WORK RINGS OF 75mm HT. IN PIT WALL	DEPTH OF CENTRE OF RING FROM GROUND LEVEL (MM)
5	2	750, 1150
10	3	750, 1150, 1450
15	3	875, 1275, 1575

ADDITION TO DRAWING NO.6

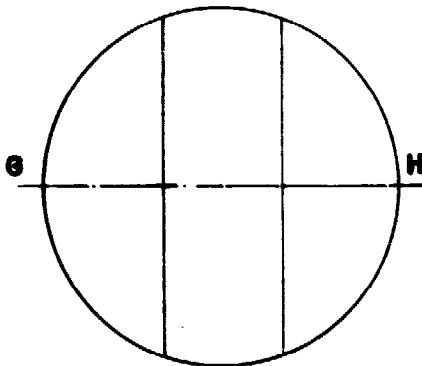

← 350 → ← 350 → ← 350 →

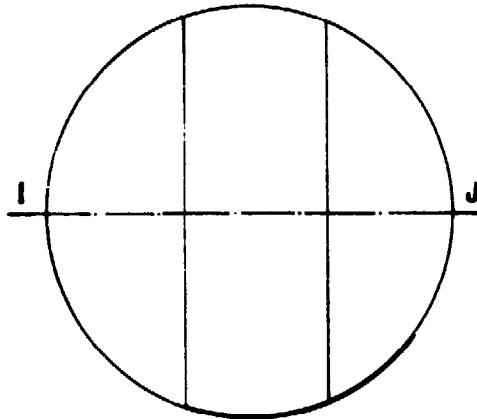

← 415 → ← 420 → ← 415 →

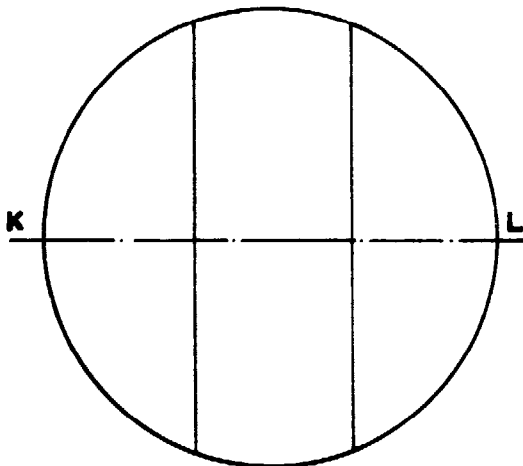

← 465 → ← 470 → ← 465 →

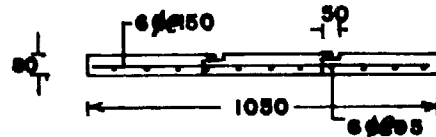

SECTION ON G H

R.C. COVER FOR 5 USERS ALTERNATE DESIGN

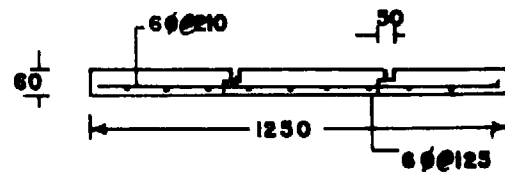

SECTION ON I J

R.C. COVER FOR 10 USERS ALTERNATE DESIGN

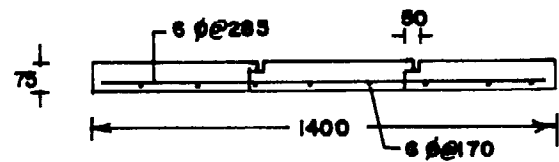

SECTION ON K L

ALL DIMENSIONS IN MM

SCALE:- 1:300

UNDP INTERREGIONAL PROJECT
INT/81/047
DEVELOPMENT AND IMPLEMENTATION
OF LOW COST SANITATION INVESTMENT
PROJECT

DESIGN OF R.C.C. COVERS

DRG. NO.
5A

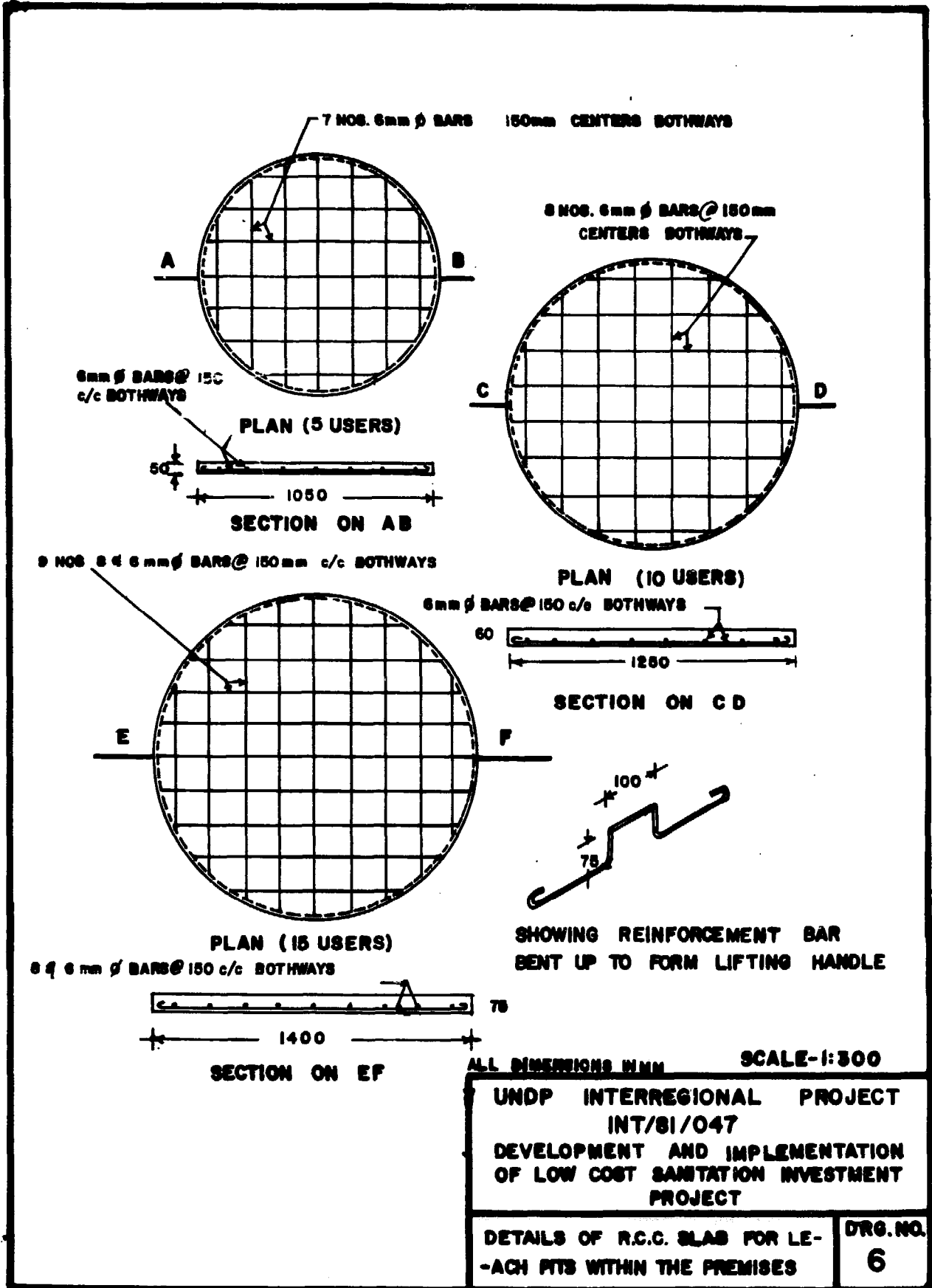

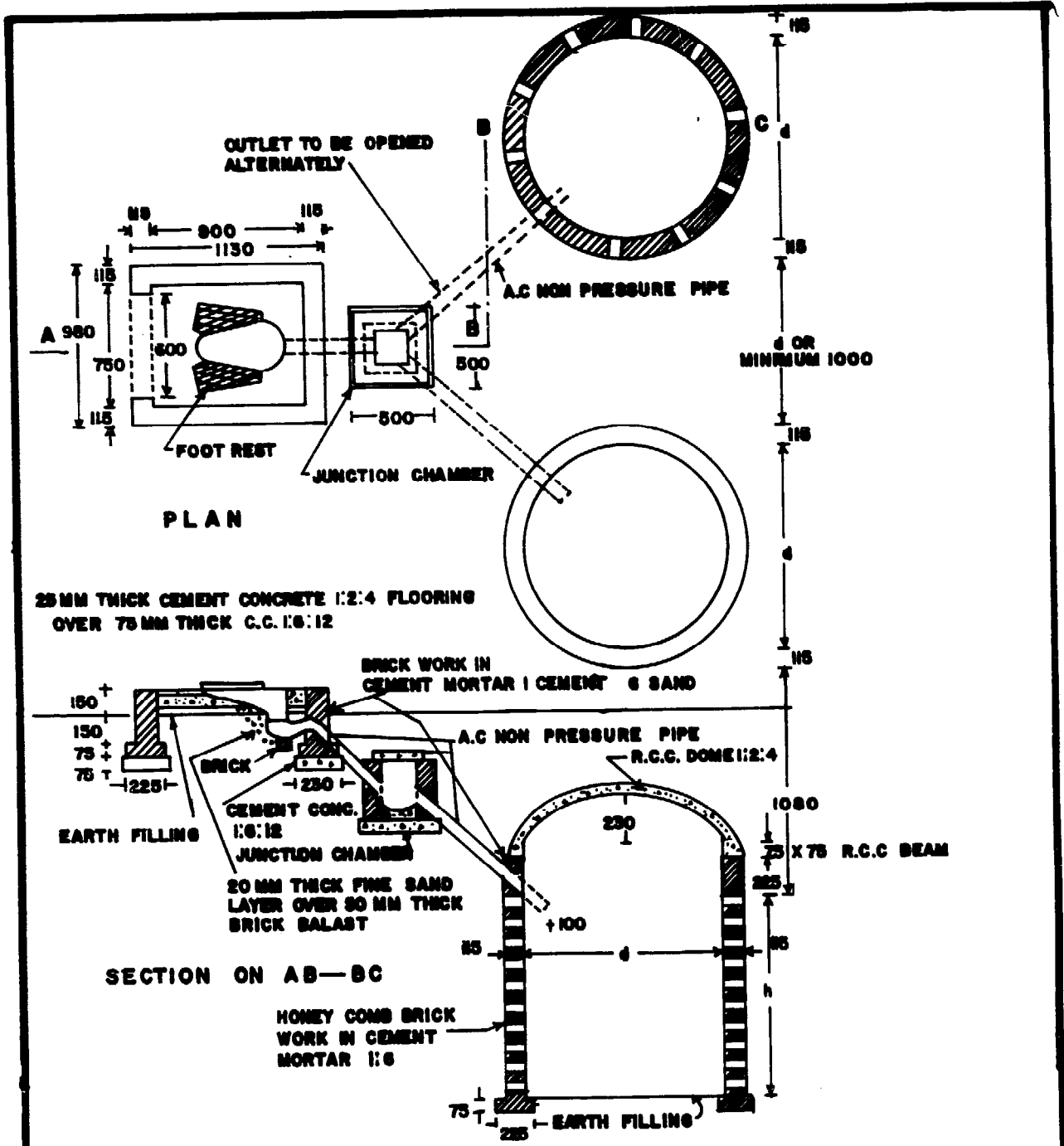

ALL DIMENSIONS IN MM SCALE-1:300

UNDP INTERREGIONAL PROJECT
INT/81/047
DEVELOPMENT AND IMPLEMENTATION
OF LOW COST SANITATION INVESTMENT
PROJECT

DESIGN OF LEACH PIT UNDER
FOOT PATH (SEE DETAIL IN 7A)

DRG. NO.
7

USERS	DIAMETER	HEIGHT	THICKNESS
	d	h	t
8	900	1100	60
10	1200	1200	65
15	1400	1300	75

ADDITION TO DRAWING NO.7

USERS	SIZE AND NO. OF RING BARS	NO. OF SOLID BRICK WORK RINGS OF 115 MM HEIGHT IN PIT WALL	DEPTH OF CENTRE OF RING FROM GROUND LEVEL (M.M.)
5	1 - 8 $\bar{\phi}$	2	1480 1880
10	1 - 8 $\bar{\phi}$	2	1530 1930
15	1 - 8 $\bar{\phi}$	2	1530 1980

ADDITION TO DRAWING NO.9

USERS	SIZE AND NO. OF RING BARS	NO. OF SOLID BRICK WORK RINGS OF 75 MM HEIGHT IN PIT WALL	DEPTH OF CENTRE OF RING FROM GROUND LEVEL (M.M.)
5	1 - 8 $\bar{\phi}$	2	1500 1900
10	2 - 8 $\bar{\phi}$	2	1600 2000
15	2 - 10 $\bar{\phi}$	2	1600 2050

ADDITION TO DRAWING NOS.16,17 AND 18

NO. OF LATRINES	NO. OF SOLID BRICK WORK RINGS IN PIT WALL AND HEIGHT OF RINGS	DEPTH OF CENTRE OF RING FROM GROUND LEVEL (M.M.)
8	4 RINGS OF 75 MM HEIGHT	980 1480 1900 2380
12	5 RINGS OF 150 MM HEIGHT	1000 1500 2000 2400 2780
15	5 RINGS OF 150 MM HEIGHT	1000 1500 2000 2400 2800

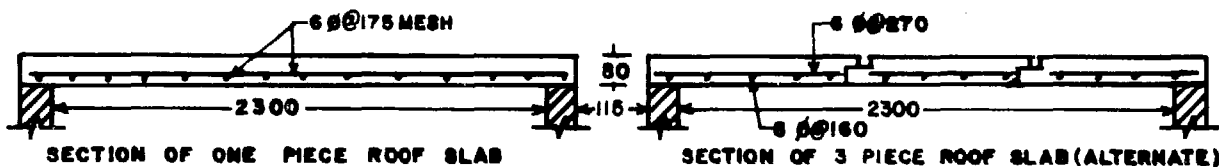
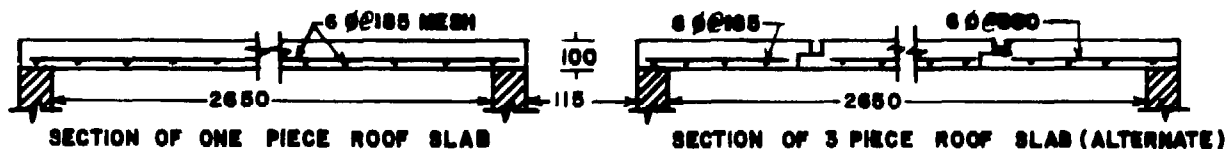
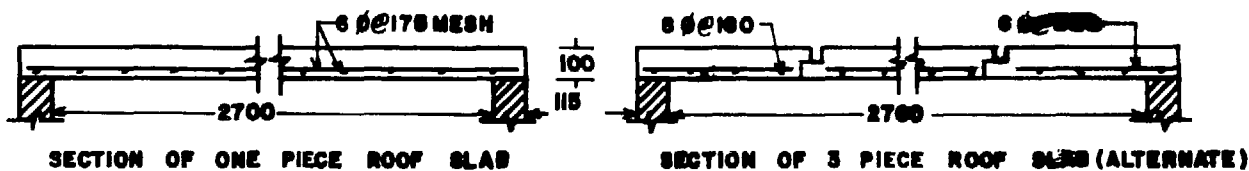
**DETAILS OF PIT ROOF FOR 8 LATRINES DRAWING NO. 16****DETAILS OF PIT ROOF FOR 12 LATRINES DRAWING NO. 17****DETAILS OF PIT ROOF FOR 16 LATRINES DRAWING NO. 18**

ALL DIMENSIONS IN MM

UNDP INTERREGIONAL PROJECT
INT/81/047
DEVELOPMENT AND IMPLEMENTATION
OF LOW COST SANITATION INVESTMENT
PROJECT

DETAILS OF PIT ROOFS

Dwg. NO.

7A

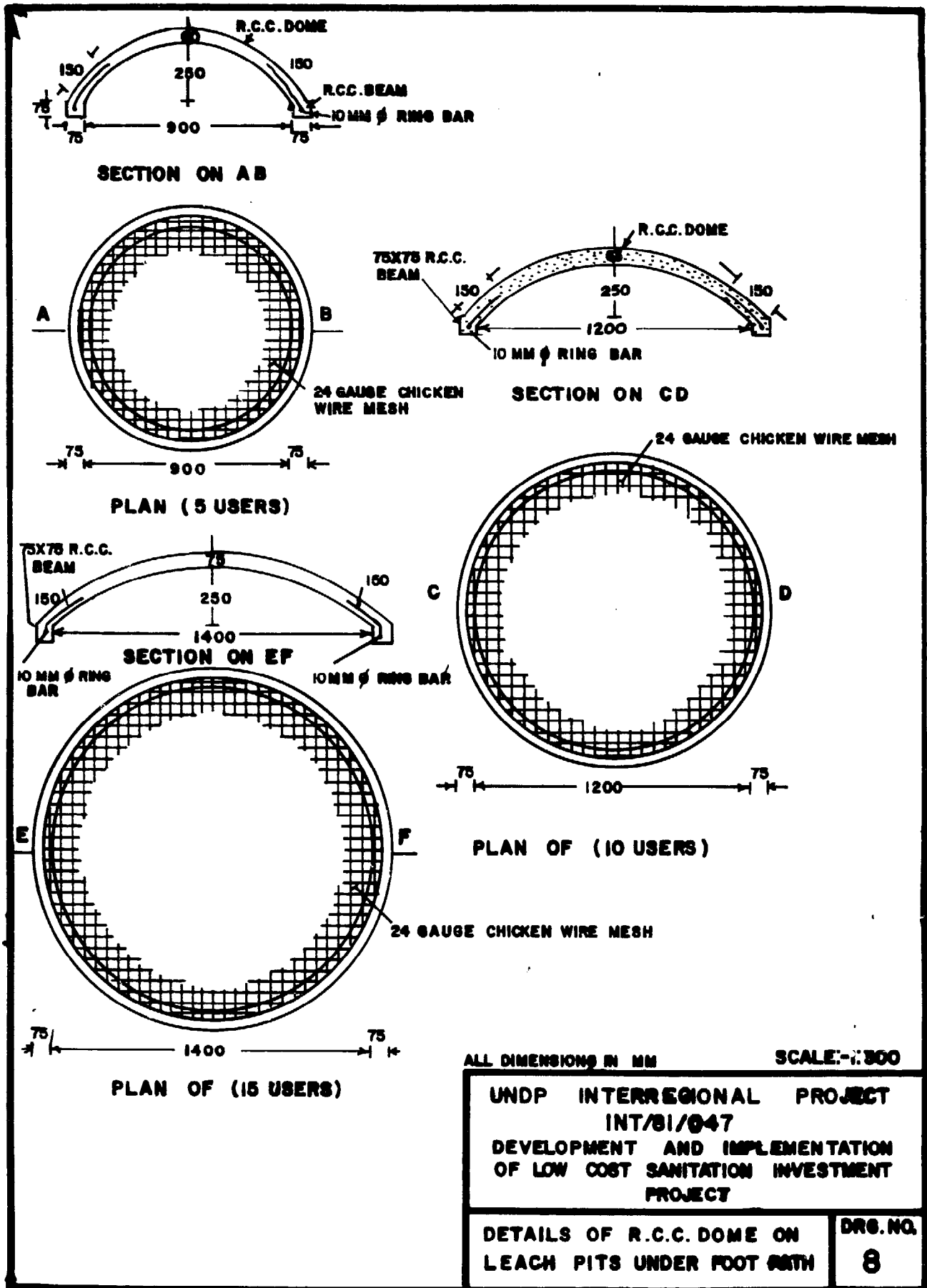

ALL DIMENSIONS IN MM SCALE:-1:300

UNDP INTERREGIONAL PROJECT
INT/81/047
DEVELOPMENT AND IMPLEMENTATION
OF LOW COST SANITATION INVESTMENT
PROJECT

DETAILS OF R.C.C. DOME ON
LEACH PITS UNDER FOOT PATH

DRG. NO.
8

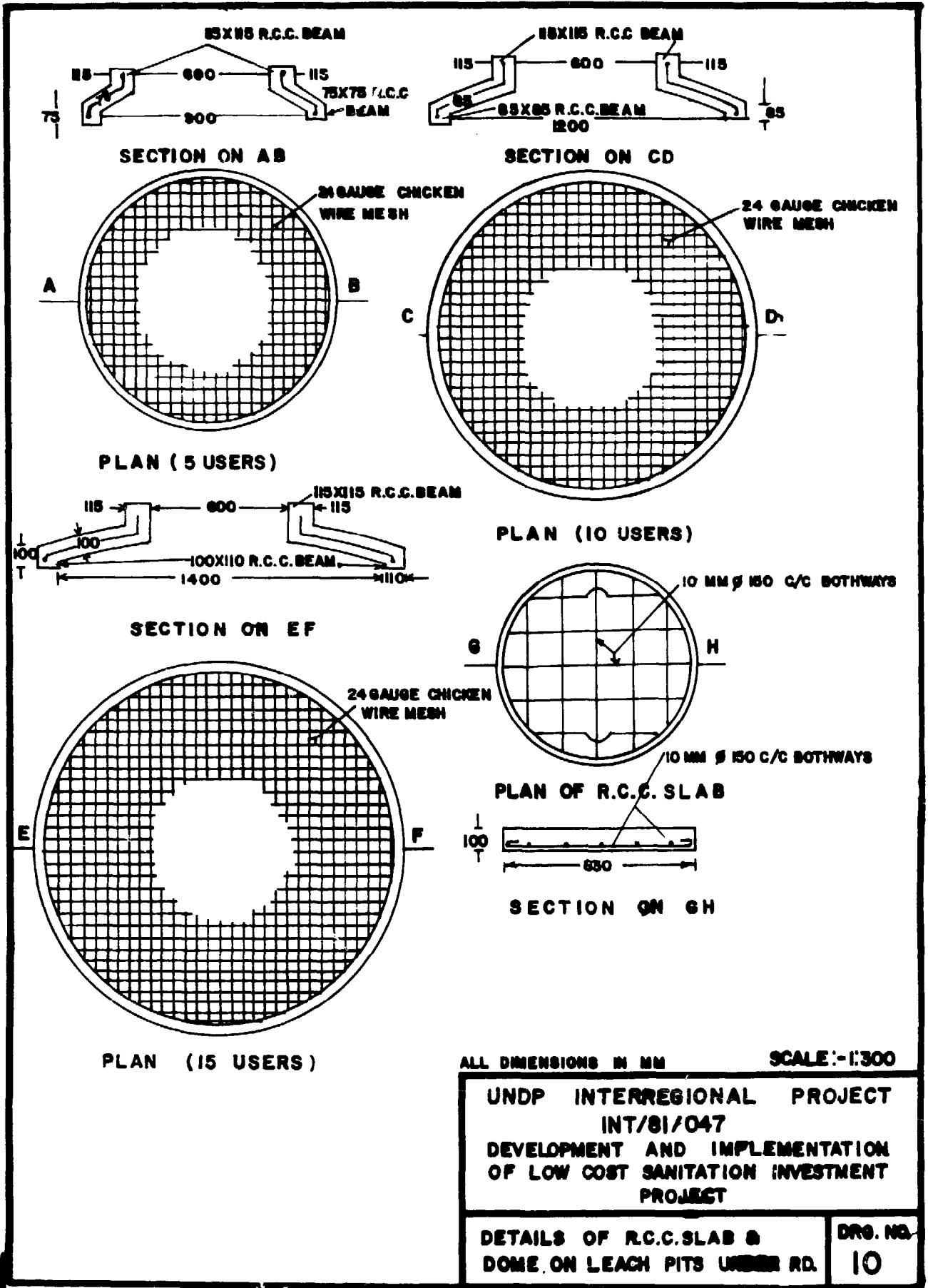

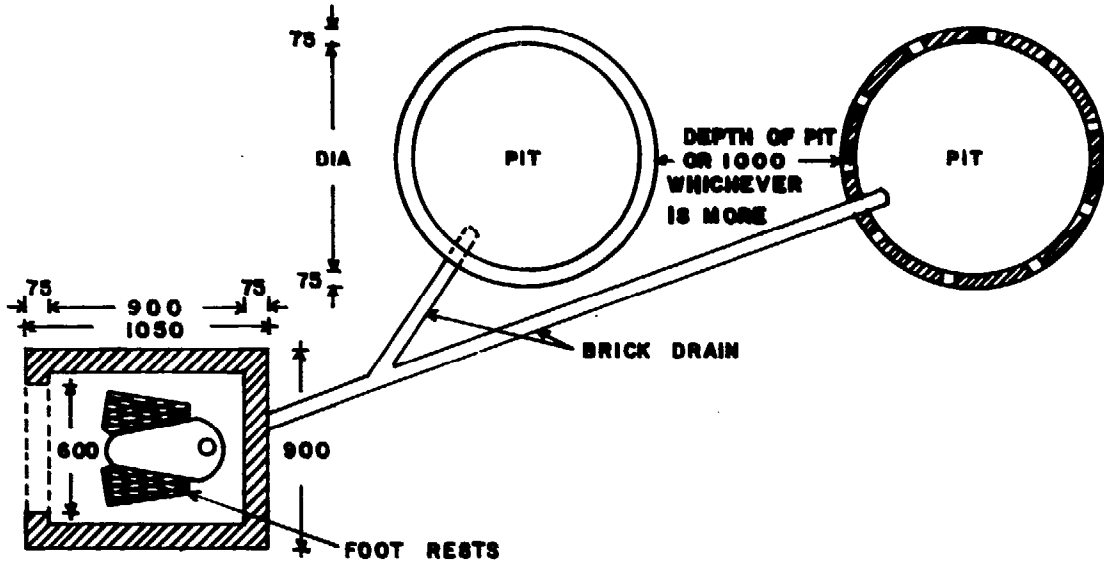

SITUATION NO.1

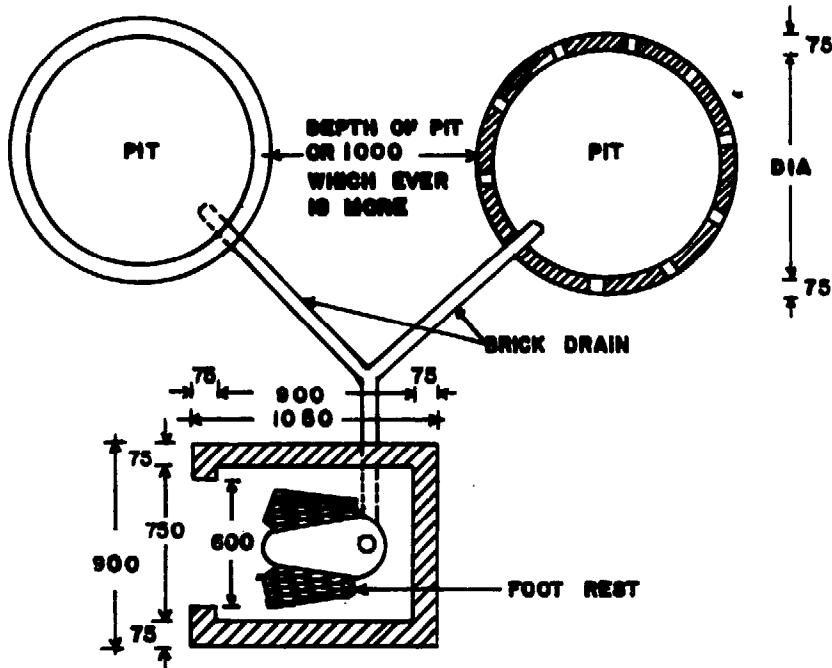

SITUATION NO.2

ALL DIMENSIONS IN MM

SCALE:-1:300

UNDP INTERREGIONAL PROJECT
 INT/81/047
 DEVELOPMENT AND IMPLEMENTATION
 OF LOW COST SANITATION INVESTMENT
 PROJECT

LAYOUT PLAN OF LEACHING PITS
 IN DIFFERENT SITUATIONS

DWG. NO.
 11

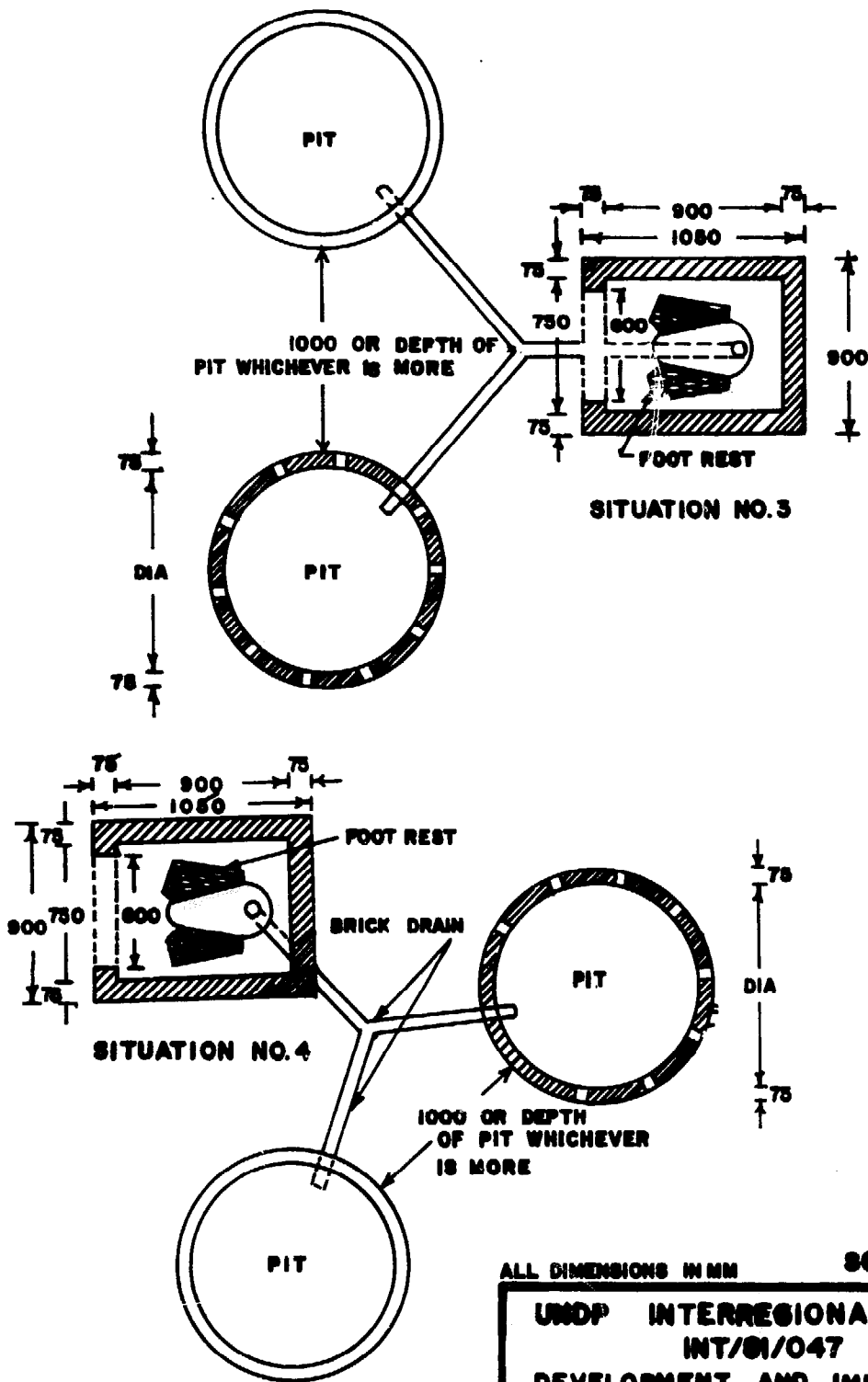

ALL DIMENSIONS IN MM SCALE-1:300

UNDP INTERREGIONAL PROJECT
INT/01/047
DEVELOPMENT AND IMPLEMENTATION
OF LOW COST SANITATION INVESTMENT
PROJECT

LAY-OUT PLAN OF LEACHING
PITS IN DIFFERENT SITUATIONS

DWG. NO.
12

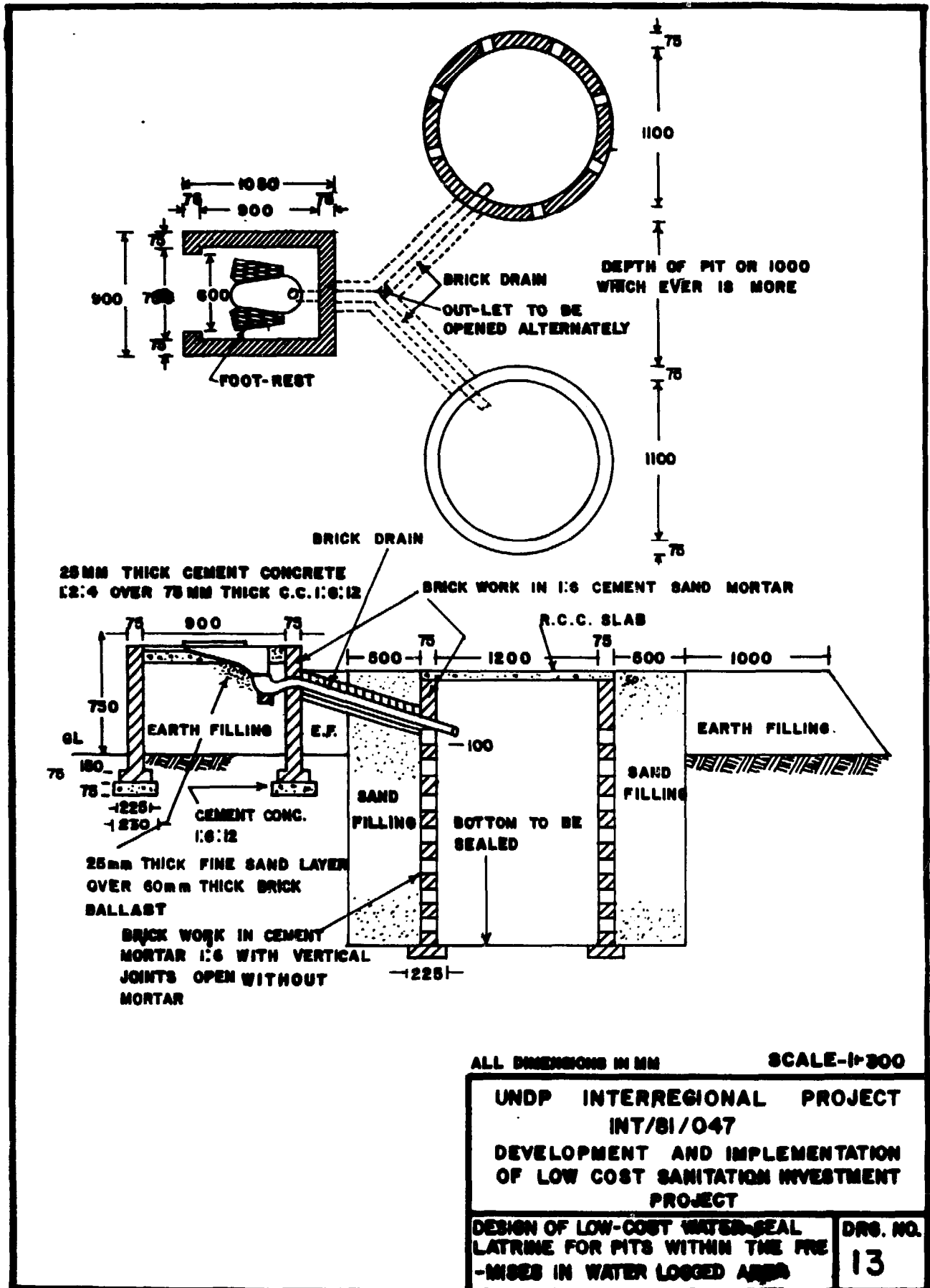

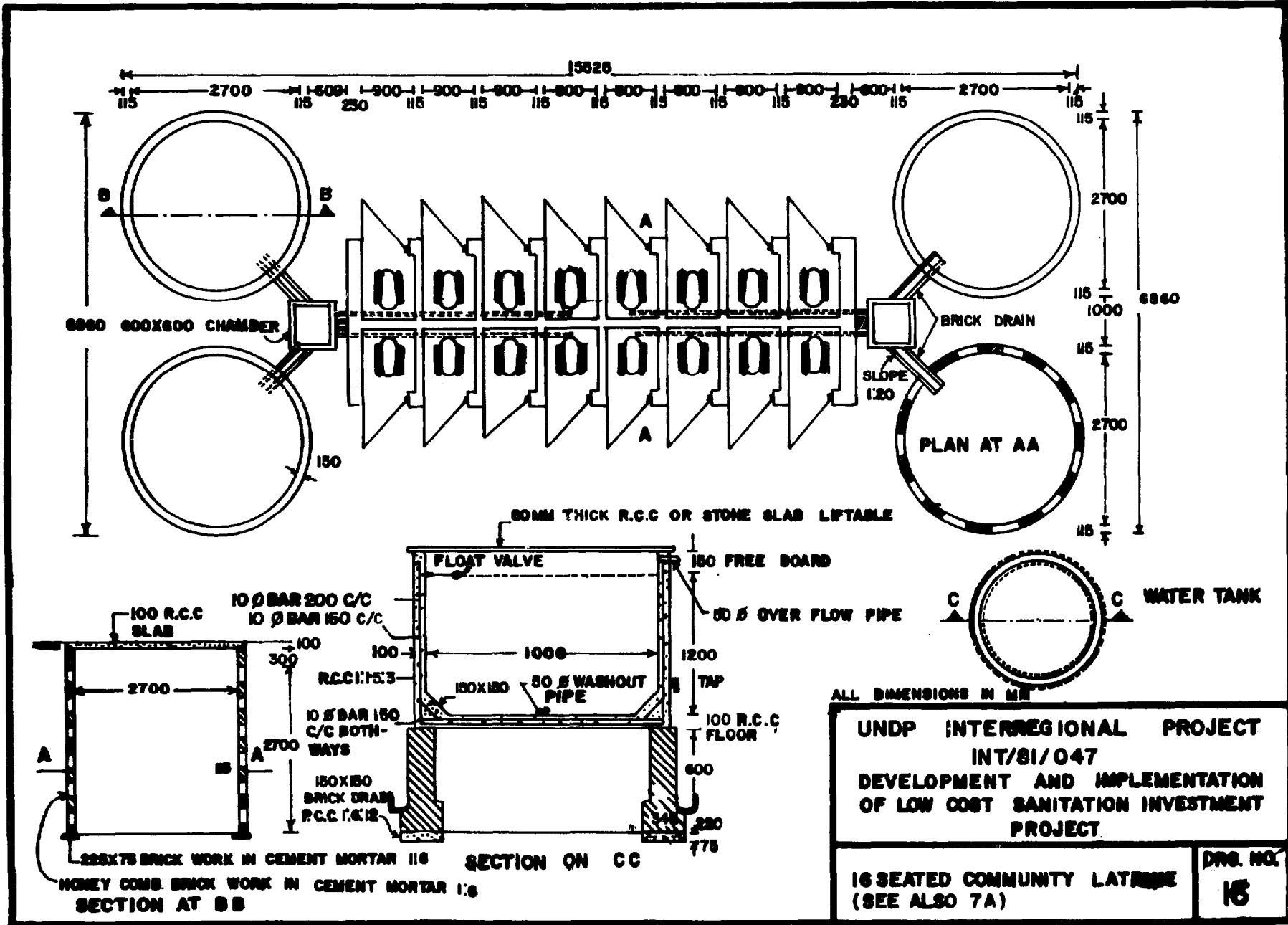

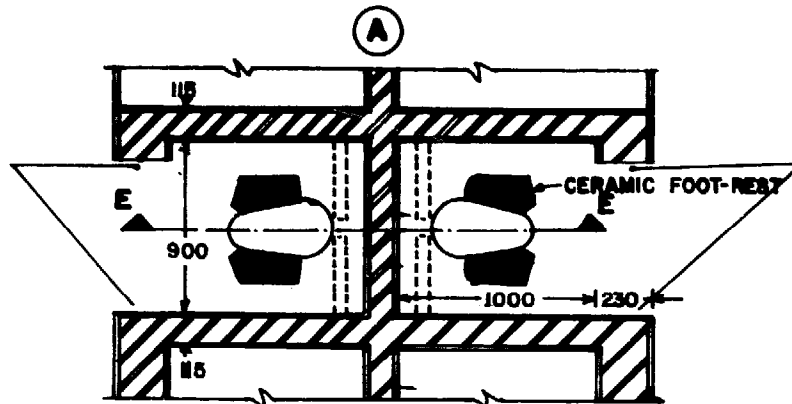

DETAIL AT A

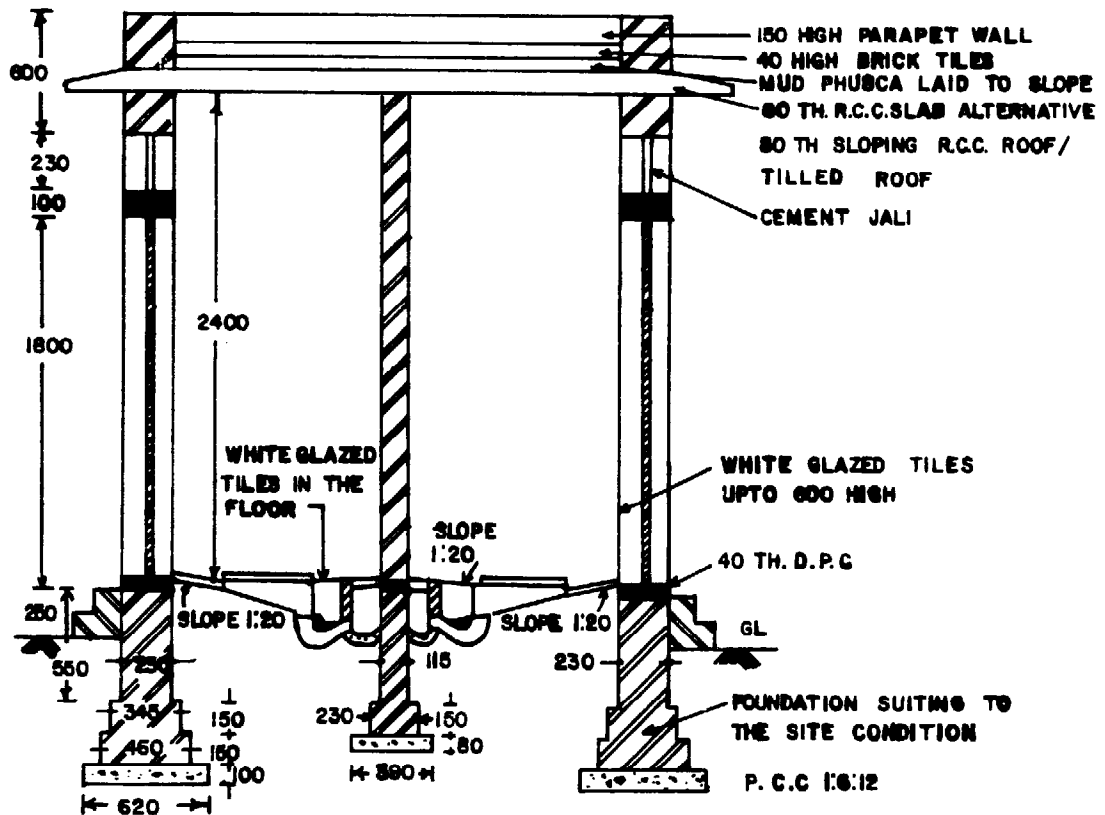

SECTION EE

ALL DIMENSIONS IN MM

SCALE:- 1:300

UNDP INTERREGIONAL PROJECT
INT/81/047
DEVELOPMENT AND IMPLEMENTATION
OF LOW COST SANITATION INVESTMENT
PROJECT

4,6,8,10,12, B16 SEATED COMMUNITY LATRINE, DETAIL AT A

DRG. NO.
17

Table 1.
Bill of quantities and cost for conversion of a
five users bucket/dry latrine with two
leaching pits within premises

Item	Unit	Quantity	Rate per unit (Rs.)	Amount (Rs.)
1. Site cleaning of the existing latrine including its disinfection	L.S	Job	L.S.	10.0
2. Dismantling of dry latrine and floor and making hole in the existing wall, including re-instatement of wall and disposal of unserviceable materials	L.S	Job	L.S.	10.0
3. Earth work in excavation, including refilling and disposal of surplus earth	L.S.	Job	L.S.	10.0
4. Supplying and fixing 425 mm GRP pan without flushing rim, 70 mm dia. ceramic or HDPE or GRP trap with 20 mm waterseal, and mosaic footrests including 20 mm sand layer over 50 mm dry brick ballast padding below the pan, and with a brick underneath the trap.	No.	1 set	110	110.0
5. Flooring: 22 mm thick cement concrete 1:2:4 (1 cement: 2 coarse sand: 4 stone ballast 6 mm to 10 mm size) over 75 mm thick cement concrete 1:6:12 (1 cement: 6 sand: 12 graded brick ballast 40 mm size) including 3 mm thick top layer consisting of four parts of cement and one part of marble dust or coarse sand, and rendering the surface smooth.	m ²	0.68	30	20.4

Table 1 (continued)

6.	Twin leach pits	No.	1 set	360	360.0
7.	Covered brick drain	m	3	26	78.0
8.	Extra carriage of materials in narrow lanes	L.S.	Job	L.S.	20.0
9.	Supervision charges 15%			Sub-total	<u>618.40</u>
					<u>92.76</u>
				Total	<u>711.16</u>
				Say	710.00

Note: (a) By substituting the cost of 10 user leach pits within premises in the above estimate, the cost of conversion of a dry latrine . for 10-user will come to Rs885.00.

(b) In households with more than 10 persons, besides the conversion of the existing bucket or dry latrine, one more flush latrine should be constructed. In such a case the quantities for construction of foundation and plinth for superstructure should also be added, and quantities against Item nos. 4 and 7 should be increased to 2 sets and 6 meters respectively.

(c) The above rates are based on Delhi Schedule of Rates at 1982 prices.

Table 2.
Bill of quantities and cost for conversion of a
five-user bucket/dry latrine with two
leaching pits under footpaths

Item	Unit	Quantity	Rate per unit (Rs.)	Amount (Rs.)
1. Site cleaning of the existing latrine including its disinfection	L.S.	Job	L.S.	10.0
2. Dismantling of dry latrine and floor and making hole in the existing wall, including re-instatement of wall and disposal of unserviceable materials	L.S.	Job	L.S.	10.0
3. Earth work in excavation, including refilling and disposal of surplus earth	L.S.	Job	L.S.	10.0
4. Supplying and fixing 425 mm GRP pan without flushing rim, 70 mm dia. ceramic or HDPE or GRP trap with 20 mm waterseal, and mosaic footrests including 20 mm sand layer over 50 mm dry brick ballast padding below the pan, and with a brick underneath the trap.	No.	1 set	100	110.0
5. Flooring: 22 mm thick cement concrete 1:2:4 (1 cement: 2 coarse sand: 4 stone ballast 6 mm to 10 mm size) over 75 mm thick cement concrete 1:6:12 (1 cement: 6 sand: 12 graded brick ballast 40 mm size) including 3 mm thick top layer consisting of four parts of cement and one part of marble dust or coarse sand, and rendering the surface smooth.	m ²	0.68	30	20.4

Table 2 (continued)

6.	Twin leach pits	No.	1 set	510	510.00
7.	Supplying and laying 75 mm dia. nonpressure AC pipe	m	4	12.00	48.00
8.	Junction chamber	No.	one	35.00	35.00
9.	Extra carriage of materials in narrow lanes	L.S.	Job	L.S	25.00
				Sub-total	<u>778.40</u>
					<u>116.76</u>
10.	Supervision charges 15%			Total	<u>895.16</u>
				Say	900.00

Note: (a) By substituting the cost of a 10-users leach pit under a footpath in the above estimate, the cost for a 10-user latrine will be Rs. 1,150.

(b) In households over 10 persons, besides the conversion of the existing bucket or dry latrine, one more pour-flush latrine should be constructed. In such a case the quantities for constructing foundation and plinth for superstructure should also be added, and quantities against Item Nos. 4 and 7 should be increased to 2 sets and 7 meters respectively.

(b) The above rates are based on Delhi Schedule of Rates at 1982 prices.

Table 3.
Bill of quantities and cost for conversion of
a five-user bucket latrine with two
leach pits under roads

Item	Unit	Quantity	Rate per unit (Rs.)	Amount (Rs.)
1. Site cleaning of the existing latrine including its disinfection	L.S.	Job	L.S.	10.00
2. Dismantling of dry latrine and floor, making hole in the existing wall including reinstatement of wall and disposal of unserviceable materials	L.S.	Job	L.S.	10.00
3. Earthwork in excavation including refilling and disposal of surplus earth	L.S.	Job	L.S.	10.00
4. Supplying and fixing 425 mm GRP pan without flushing rim, 70 mm dia. ceramic, HDPE or GRP trap with 20 mm waterseal, and mosaic footrests including 20 mm sand layer over 50 mm dry brick ballast padding below the pan, and with a brick underneath the trap	No.	1 set	110	110.00
5. Flooring:--22 mm thick cement concrete 1:2:4 (1 cement: 2 coarse sand: 4 stone ballast 6 mm to 10 mm size) over 75 mm thick cement concrete 1:6:12 (1 cement: 6 sand: 12 graded brick ballast 40 mm size) including 3 mm thick top layer consisting of 4 parts of cement and one part of marble dust or coarse sand, and rendering the surface smooth	m ²	0.68	30	20.40

Table 3 (continued)

6.	Two leach pits	No.	1 set	740.00	740.00
7.	Supplying and laying 75 mm dia. nonpressure AC pipe	m	4	12.00	48.00
8.	Junction chamber	No.	1	35.00	35.00
9.	Extra carriage of materials in narrow lanes	L.S.	Job	L.S.	25.00
				Sub-total	1,008.40
					151.26
10.	Supervision charges 15%			Total	1,159.66
				Say	1,160.00

Note: (a) By substituting the cost of 10-user leach pits in the above estimate, the cost for conversion of a dry latrine for 10 users be Rs. 1,260.00.

(b) In households with more than 10 persons, besides the conversion of the existing bucket or dry latrine, one more pour-flush latrine should be constructed. In such a case the quantities for constructing foundation and plinth for superstructure should be added, and quantities against Item Nos. 4 and 7 should be increased to 2 sets and 7 meters respectively.

(c) The above rates are based on Delhi Schedule of Rates at 1982 prices.

Table 4.
Bill of quantities and cost for a
5-user new pour-flush latrine with two
leach pits within the premises .

Item	Unit	Quantity	Rate per unit (Rs.)	Amount (Rs.)
1. Foundation and plinth for super-structure				
(a) Earthwork in excavation including refilling of trenches and disposal of surplus earth	m ³	0.26	5.00	1.30
(b) Cement concrete 1:6:12 (1 cement: 6 sand: 12 graded brick ballast 40 mm size)	m ³	0.27	230.00	16.10
(c) First-class brickwork in cement mortar 1:6 (1 cement: 6 sand)	m ³	0.193	375.00	72.38
(d) Flooring:--22 mm thick cement concrete 1:2:4 (1 cement: 2 coarse sand: 4 stone ballast 6 mm to 10 mm size) over 75 mm thick cement concrete 1:6:12 (1 cement: 6 sand: 12 graded brick ballast 40 mm size) including 3 mm thick top layer consisting of four parts of cement and one part of marble dust or coarse sand and rendering the surface smooth	m ²	0.68	30.00	20.40

Table 4 (continued)

2.	Supplying and fixing 425 mm GRP pan without flushing rim, 70 mm dia. ceramic, HDPE or GRP trap with 20 mm waterseal, and a pair of mosaic footrests, including 20 mm sand layer over 50 mm dry brick ballast padding below the pan, and a brick underneath the trap	No.	1 set	110.00	110.00
3.	Twin leach pits	No.	1 set	360.00	360.00
4.	Covered brick drain	m	3	26.00	78.00
5.	Extra carriage of materials in narrow lanes	L.S.	Job	L.S.	27.00
				Sub-total	<u>685.18</u>
6.	Supervision charges 15%				<u>102.78</u>
				Total	787.96
				Say	790.00

Note: (a) By substituting the cost of 10-user leach pits within premises in the above estimate, the cost of constructing a new latrine for 10 users be Rs. 960.00

(b) In households with more than 10 persons, 2 latrine seats should be provided, and length of covered drain should be increased to 6 meters. The quantities of items under "Foundation and plinth for superstructure" should be doubled.

(c) The above cost is based on Delhi Schedule of Rates at 1982 prices.

Table 5.
Bill of quantities and cost for a
5-user pour-flush latrine with two
leach pits located under footpath

Item	Unit	Quantity	Rate per unit (Rs.)	Amount (Rs.)
1. Foundation and plinth for super-structure				
(a) Earthwork in excavation including refilling of trenches and disposal of surplus earth	m ³	0.26	5.00	1.30
(b) Cement concrete 1:6:12 (1 cement: 6 sand: 12 graded brick ballast 40 mm size)	m ³	0.07	230.00	16.10
(c) First-class brick work in cement mortar 1:6 (1 cement: 6 sand)	m ³	0.193	375.00	72.38
(d) Flooring:--22 mm thick cement concrete 1:2:4 (1 cement: 2 coarse sand: 4 stone ballast 6 mm to 10 mm size) over 75 mm thick cement concrete 1:6:12 (1 cement: 6 sand: 12 graded brick ballast 40 mm size) including 3 mm thick top layer consisting of four parts of cement and one part of marble dust or coarse sand and rendering the surface smooth	m ²	0.68	30.00	20.40

Table 5 (continued)

2.	Supplying and fixing 425 mm GRP pan without flushing rim, 70 mm dia. ceramic, HDPE or GRP trap with 20 mm waterseal, and cement mosaic footrests including 20 mm sand layer over 50 mm dry brick ballast padding below the pan, and a brick underneath the trap	No.	1 set	110.00	110.00
3.	Twin leach pits	No.	1 set	510.00	510.00
4.	Supplying and laying 75 mm dia. nonpressure AC pipe	m	4	12.00	48.00
5.	Junction chamber	No.	1	35.00	35.00
6.	Extra carriage of materials in narrow lanes	L.S.	Job	L.S.	30.00
				Sub-total	<u>843.18</u>
6.	Supervision charges 15%				<u>126.48</u>
				Total	969.66
				Say	970.03

Note: (a) By substituting the cost of 10-user leach pits under footpath in the above estimate, the cost of constructing a new latrine for 10 users will come to Rs. 1,225.00

(b) In households with more than 10 persons, 2 latrine seats should be provided and length of AC pipe against Item 4 should be increased to 7 meters. The quantities of items under "foundation and plinth for superstructure" should be doubled.

(c) The above cost is based on Delhi Schedule of Rates at 1982 prices.

Table 6.
Bill of quantities and cost for a new
5-user pour-flush latrine with two
leach pits located under roads

Item	Unit	Quantity	Rate per unit (Rs.)	Amount (Rs.)
1. Foundation and plinth for super-structure				
(a) Earthwork in excavation including refilling of trenches and disposal of surplus earth	m ³	0.26	5.00	1.30
(b) Cement concrete 1:6:12 (1 cement: 6 sand: 12 graded brick ballast 40 mm size)	m ³	0.07	230.00	16.10
(c) First-class brickwork in cement mortar 1:6 (1 cement: 6 sand)	m ³	0.193	375.00	72.38
(d) Flooring:--22 mm thick cement concrete 1:2:4 (1 cement: 2 coarse sand: 4 stone ballast 6 mm to 10 mm size) over 75 mm thick cement concrete 1:6:12 (1 cement: 6 sand: 12 graded brick ballast 40 mm size) including 3 mm thick top layer consisting of four parts of cement to one part of marble dust or coarse sand and rendering the surface smooth	m ²	0.68	30.00	20.40

Table 6 (continued)

2.	Supplying and fixing 425 mm GRP pan without flushing rim, 70 mm dia. ceramic, HDPE or GRP trap with 20 mm waterseal, and cement mosaic footrests including 20 mm sand layer over 50 mm dry brick ballast padding below the pan, and a brick underneath the trap	No.	1 set	110.00	110.00
3.	Two leach pits	No.	1 set	740.00	740.00
4.	Supplying and laying 75 mm dia. nonpressure AC pipe	m	4	12.00	48.00
5.	Junction chamber	m	1	35.00	35.00
6.	Extra carriage of materials in narrow lanes	L.S.	Job	L.S.	30.00
6.	Supervision charges 15%			Sub-total	1,073.18
					<u>160.98</u>
				Total	1,234.16
				Say	1,240.00

Note: (a) By substituting the cost of 10-user leach pits under road in the above estimate, the cost for a 10-user latrine may be calculated at Rs 1,430.00

(b) In households with more than 10 persons, 2 latrine seats should be provided and the length of AC pipe in Item No.4 should be increased to 7 meters. The quantities of items under "foundation and plinth for superstructure" should be doubled.

(c) The above rates are based on Delhi Schedule of Rates at 1982 prices.

Table 7.
Bill of quantities for covered brick
drain one meter in length

Item	Unit	Quantity	Rate per unit (Rs.)	Amount (Rs.)
Earth work in excavation including refilling of trenches and disposal of surplus earth	Job	Job	L.S.	2.00
Cement concrete 1:6:12 (1 cement 6 sand: 12 graded brick ballast 40 mm size)	m ³	0.026	230	5.98
First-class brick-work in cement mortar 1:6 (1 cement 6 sand)	m ³	0.017	375	6.38
First-class brick work in mud mortar	m ³	0.017	300	5.10
Cement concrete 1:2:4 (1 cement 2 coarse sand: 4 stone ballast 6 mm to 10 mm size) including rendering the surface smooth with neat cement	m ³	0.005	500	2.50
12 mm thick cement plaster 1:4 (1 cement: 4 coarse sand) including making the surface smooth with neat cement	m ²	0.15	10	1.50
Extra cost for rendering the plaster smooth with neat cement and making the corners round	L.S.	Job	L.S.	<u>2.00</u>
			Total	25.46
			Say	<u>26.00</u>

Note: Cost based on Delhi Schedule of Rates at 1982 prices.

Table 8.
Bill of quantities for a
junction chamber

Item	Unit	Quantity	Rate per unit (Rs.)	Amount (Rs.)
1. Earthwork in excavation including refilling of trenches and disposal of surplus earth	m ³	0.15	5	0.75
2. Cement concrete 1:6:12 (1 cement:6 sand: 12 graded brick ballast 40 mm size)	m ³	0.019	230	4.37
3. First-class brickwork in cement mortar 1:6 (1 cement:6 sand)	m ³	0.05	375	18.75
4. Cement concrete 1:2:4 (1 cement: 2 coarse sand: 4 stone ballast 6 mm to 10 mm size) including rendering the surface smooth with neat cement	m ³	0.0016	500	0.80
5. Reinforce cement concrete 1:2:4 (1 cement: 2 coarse sand: 4 graded stone ballast 20 mm size) in precastslab excluding reinforcement	m ³	0.0042	600	2.52
6. M.S. steel bars for RCC work in precast slab	Job	Job	L.S.	5.00
7. 12 mm thick cement plaster 1:4 (1 cement: 4 coarse sand)	m ³	0.28	10	2.80
			Total	34.99
			Say	<u>35.00</u>

Note: The above rates are based on Delhi Schedule of Rates at 1982 price.

Table 9.
Bill of quantities for foundation and
plinth for superstructure of
a new latrine

Item	Unit	Quantity	Rate per unit (Rs.)	Amount (Rs.)
Earth work in excavation including refilling of trenches and disposal of surplus earth	m ³	0.26	5	1.30
Cement concrete 1:6:12 (1 cement:6 sand: 12 graded brick ballast 40 mm size)	m ³	0.07	230	16.10
First class brickwork in cement mortar 1:6 (1 cement 6 sand)	m ³	0.193	375	72.38
Flooring: --22 mm thick cement concrete 1:2:4 (1 cement: 2 coarse sand: 4 stone ballast 6 mm to 10 mm size) over 75 mm thick cement concrete 1:6:12 (1 cement: 6 sand: 12 graded brick ballast 40 mm size) including 3 mm thick toplayer consisting of 4 parts of cement and one part of marble dust or coarse sand and rendering the surface smooth	m ²	0.68	30	<u>20.40</u>
			Total	110.18
			Say	<u>110.00</u>

Note: The above rates are based on Delhi Schedule of Rates at 1982 prices.

Table 10.
Bill of quantities for a superstructure
of latrine

Item	Unit	Quantity	Rate per unit (Rs.)	Amount (Rs.)
20 mm thick damp proof course	m ²	0.23	30	6.90
First class brick work in cement mortar 1:6	m ³	0.49	375	183.75
Reinforced cement concrete 1: 2:4 precast slab and door lintel	m ³	0.075	600	45.00
M.S. steel bars for RCC work and angle iron chaukhat	Kg.	5.00	6.0	30.00
Mild steel hold-fasts	No.	4.00	L.S.	8.00
30 mm thick single leaf chir or kail wood panelled door shutter with iron fittings	m ²	0.72	112	80.64
Painting of door.	m ²	1.44	L.S.	10.00
12 mm thick cement plaster 1:4 with coarse sand	m ²	0.82	11	9.02
Making the plaster smooth with neat cement	Job	L.S	L.S.	<u>5.00</u>
			Total	378.31
			Say	380.00

Note: The above rates are based on Delhi Schedule of Rates at 1982 prices.

Table 11.
Bill of quantities and cost of a leach pit (within premises)

Item	Unit	Rate per unit (Rs.)	5-users		10-users		15-users	
			Quantity	Cost (Rs.)	Quantity	Cost (Rs.)	Quantity	Cost (Rs.)
1. Earthwork in excavation, including refilling of trenches and disposal of surplus earth.								
(a) Up to 1.5 m below ground level	m ³	5.00	1.72	8.60	2.31	11.55	2.83	14.15
(b) 1.5 m to 3.0 m below ground level	m ³	5.50	-	--	0.51	2.81	1.04	5.72
2. First-class brickwork in cement mortar 1:6 (1 cement: 6 sand)	m ³	375.00	0.12	45.00	0.15	56.25	0.16	60.00
3. Honeycomb brick work in cement mortar 1:6 with 3"x4 1/2" holes	m ³	400.00	0.19	76.00	0.29	116.00	0.37	148.00
4. Reinforced cement concrete 1:2:4 (1 cement: 2 coarse sand: 4 graded stone ballast 20 mm size) in precast slab excluding reinforcement; but including making top surface smooth with neat cement	m ³	600.00	0.043	25.80	0.074	44.40	0.115	69.00
5. M.S. Steel bars RCC work	Kg.	6.00	3.50	21.00	4.00	24.00	6.00	36.00
				176.40		255.01		332.87
				180.00		255.00		335.00

Noted: 1. For twin leach pits, the above quantities should be doubled.

2. The above rates are based on Delhi Schedule of Rates at 1982 prices.

Table 12.
Bill of quantities and cost of a leach pit under foot-path or lanes

Item	Unit	Rate per unit (Rs.)	5-users		10-users		15-users	
			Quantity	Cost (Rs.)	Quantity	Cost (Rs.)	Quantity	Cost (Rs.)
1. Earthwork in excavation including refilling of trenches and disposal surplus earth.								
(a) Up to 1.5 m below ground level	m ³	5.00	1.81	9.05	2.79	13.95	3.99	19.95
(b) 1.5 m to 3.00 m below ground level	m ³	5.50	0.91	5.01	1.59	8.75	2.26	12.43
2. First-class brickwork in cement mortar 1:6 (1 cement: 6 sand)	m ³	375.00	0.14	52.50	0.177	66.38	0.204	76.50
3. Honeycomb brickwork in cement mortar 1:6 with 3"x 4 1/2" holes	m ³	400.00	0.303	121.20	0.428	171.20	0.534	213.60
4. Reinforced cement concrete 1:2:4 (1 cement: 2 coarse sand: 4 graded stone ballast) in beam and dome excluding reinforcement but including rendering the top surface smooth	m ³	720.00	0.077	55.44	0.114	82.08	0.174	125.28
5. Mild steel bars in reinforced cement concrete work	Kg.	6.00	1.30	7.80	2.60	15.60	3.00	18.00
6. 24 gauge chicken wire mesh	m ³	7.00	0.60	4.20	0.75	5.25	0.85	5.95
		Total		255.20		363.21		471.71
		Say		255.00		365.00		470.00

Note: 1. For twin leach pits, the above quantities should be doubled.

2. The above rates are based on Delhi Schedule of Rates at 1982 prices.

Table 13.
Bill of quantities and cost of a leach pit under road

Item	Unit	Rate per unit (Rs.)	5-users		10-users		15-users	
			Quantity	Cost (Rs.)	Quantity	Cost (Rs.)	Quantity	Cost (Rs.)
1. Earthwork in excavation including refilling of trenches and disposal surplus earth:								
(a) Up to 1.5 m below ground level	m ³	5.00	1.81	9.05	2.79	13.95	3.57	17.85
(b) 1.5 m to 3.0 m below ground level	m ³	5.50	0.94	5.17	1.63	8.97	2.32	12.76
2. First-class brickwork in cement mortar 1:6 (1 cement: 6 sand)	m ³	375.00	0.056	21.00	0.07	26.25	0.081	30.38
3. First-class brickwork in cement mortar 1:4 (1 cement: 4 coarse sand)	m ³	450.00	0.18	81.00	0.18	81.00	0.18	81.00
4. Honeycomb brickwork in cement mortar 1:6 with 3"x 4 1/2" holes	m ³	400.00	0.303	121.20	0.428	171.20	0.534	213.60
5. Reinforced cement concrete 1:2:4 (1 cement: 2 coarse sand: 4 graded stone ballast) in beam and dome excluding reinforcement but including rendering top surface smooth	m ³	720.00	0.076	54.72	0.093	66.96	0.114	82.08
6. Reinforced cement concrete 1:2:4 in slab excluding reinforcement	m ³	600.00	0.054	32.40	0.054	32.40	0.054	32.40
7. Mild steel bars in reinforced cement concrete work	Kg.	6.00	7.00	42.00	7.50	45.00	8.00	48.00
8. 24 gauge chicken wire mesh	m ³	7.00	0.57	3.99	1.03	7.21	1.45	10.15
		Total		370.53		452.94		528.22
		Say		370.00		455.00		530.00

Note: 1. For twin leach pits, the above quantities should be doubled.

2. Above rates are based on Delhi Schedule of Rates at 1982 prices.

Table 14.
Cost of Community Latrine
(8 seats)

	Item	Unit	Rate per unit (Rs.)	Quantity	Amount (Rs.)
1.	Excavation in foundation	m ³	5.00	6.5	33.00
2.	Plain cement concrete in 1:6:12 mix	m ³	230.00	1.39	320.00
3.	First-class brickwork in foundation and plinth in 1:6 cement mortar	m ³	375.00	6.8	2,550.00
4.	Damp proof course (25 mm thick) in 1:2 cement mortar	m ³	30.00	6.60	198.00
5.	Reinforced cement concrete in 1:2:4 mix including steel	m ³	700.00	1.39	973.00
6.	First-class brickwork in superstructure in 1:6 cement mortar	m ³	400.00	12.55	5,020.00
7.	Tar or bitumen felt over RCC roof	m ³	30.00	13.99	420.00
8.	Ruled pointing in 1:4 cement mortar	m ³	8.50	35.45	301.00
9.	Plaster in 1:6 cement mortar	m ³	10.00	49.97	500.00
10.	White washing in three coats	m ³	0.60	57.20	34.00
11.	Providing and fixing Kota stone flooring fixed in cement mortar 1:4 complete with wax polishing	m ³	100.00	23.00	2,300.00
12.	Supplying and fixing wooden shutters	m ²	112.00	10.50	1210.00
13.	Supplying and fixing GRP squatting pan (425 mm), trap and foot-rests	No.	110.00	8.00	880.00

Table 14 (continued)

14. Supplying all materials and constructing 50 mm thick 1:2:4 flooring over 80 mm thick 1:6:12 cement concrete	m ³	30.00	12.50	275.00
15. Constructing 150 mm dia. semi-circular drain in brick masonry in 1:6 cement mortar	m	40.00	16.00	640.00
	No.	L.S.	4	10,000.00
16. Leach pits as per drawing	No.	45.00	10	450.00
17. Fixing of electricity points	No.	L.S.	1	1,500.00
18. Water tank including water connection			Sub-Total	<u>27,704.00</u>
				4,155.60
19. Supervision charges 15%			Total	<u>31,859.60</u>
			Say	32,000.00

Note: The above rates are based on Delhi Schedule of Rates at 1982 prices.

**Table 15.
Cost of Community Latrines
(12 seated)**

	Item	Unit	Quantity	Rate per unit (Rs.)	Amount (Rs.)
1.	Excavation in foundation	m ³	5.00	9.12	43,000.00
2.	Plain cement concrete in 1:6:12	m ³	230.00	1.91	439.00
3.	First Class brick work in foundation and plinth 1:6 cement mortar	m ³	375.00	9.50	3,563.00
4.	Damp proof course (25 mm thick) in 1:2 cement mortar	m ²	30.00	9.16	275.00
5.	Reinforced cement concrete in 1:2:4 mix including steel	m ³	700.00	2.32	1,624.00
6.	First class brick work in superstructure in 1:6 cement mortar	m ³	400.00	17.21	6,884.00
7.	Providing all materials and fixing tar or bitumen felt over RCC roof slab	m ²	30.00	20.43	613.00
8.	Ruled pointing in 1:4 cement mortar	m ²	8.50	42.95	365.00
9.	Plaster in 1:6 cement mortar	m ²	10.00	75.00	750.00
10.	White washing in 3 coats	m ²	0.60	85.00	51.00
11.	Providing and fixing Kota stone flooring in cement mortar 1:4 complete with wax polishing	m ²	100.00	34.00	3,500.00
12.	Supply and fixing wooden shutters	m ²	112.00	16.20	1,814.00

Table 15 (continued)

13. Supply and fixing FRP squatting pan (425 mm), trap and footrests	No.	110.001	1200	1,329.99
14. Construct 50 mm thick 1:2:4 flooring over 80 mm thick 1:6:12 cement concrete	m ²	30.00	18.60	558.00
15. Construct 150 mm dia. semi-circular drain in brick masonry in 1:6 cement mortar	m	40.00	20.00	800.00
	No.	L.S.	4	12,000.00
16. Construct leach pits	No.	45.00	14	630.00
17. Fixing of electricity points	No.	L.S.	1	1,900.00
18. Construct water tank including water connection				<u>37,032.00</u>
				5,554.80
19. Supervision charges 15%				<u>42,586.80</u>
		Total		43,000.00
		Say		

Note: The above rates are based on Delhi schedule of rates at 1982 prices.

**Table 16.
Cost of Community Latrines
(16 seated)**

Item	Unit	Rate per Unit (Rs.)	Quantity	Amount (Rs.)
1. Excavation in foundation	m ³	5.00	11.59	58.00
2. Plain cement concrete in 1:6:12 mix	m ³	230.00	2.45	564.00
3. First class brick work in foundation and plinth in 1:6 cement mortar	m ³	375.00	12.28	4,605.00
4. Damp proof course (25 mm thick) in 1:2 cement mortar	m ²	30.00	11.72	352.00
5. RCC in 1:2:4 mix including steel	m ³	700.00	3.07	2,149.00
6. First class brick work in superstructure in 1:6 cement mortar	m ³	400.00	23.43	9,372.00
7. Fixing of tar or bitumen felt over RCC roof slab	m ²	30.00	26.88	806.00
8. Ruled pointing in 1:4 cement mortar	m ²	8.50	50.50	429.00
9. Plaster in 1:6 cement mortar	m ²	10.00	100.00	1,000.00
10. White washing in 3 coats	m ²	0.60	114.00	68.00
11. Providing and fixing Kota stone flooring in cement mortar 1:4 complete with wax polishing	m ²	100.00	45.00	4,500.00
12. Supply and fixing wooden shutters	m ²	112.00	21.60	2,419.00
13. Supply and fixing FRP squatting pan (425 mm), trap and footrests	No.	110.00	16.00	1,760.00

Table 16 (continued)

14.	Construct 50 mm thick 1:2:4 concrete flooring over 80 mm thick 1:6:12 cement concrete	m ²	30.00	25.00	750.00
15.	Construct of 150 mm dia. semi-circular drain in brick masonry in 1:6 cement mortar	m	40.00	24.00	960.00
16.	Construct leach pits as per drawing	No.	L.S.	4.00	13,000.00
17.	Fixing of electricity point	No.	45.00	18.00	810.00
18.	Construct water tank including water connection	No.	L.S.	1.00	3,000.00
			Sub-total		46,602.00
19.	Supervision charges 15%				6,990.00
			Total		53,592.30
			Say		54,000.00

Note: The above rates are based on Delhi Schedule of rates at 1982 prices.

Table 17
Materials and labor required for conversion of a bucket latrine
with leach pits within the premises

Item	Unit	Quantity		
		5-user	10-user	15-user
Materials				
1. Bricks	Nos.	370	500	750
2. Cement	Bags	2.25	3.00	5.00
3. Local sand	Cum	0.26	0.33	0.57
4. Coarse sand	Cum	0.06	0.09	0.15
5. Brick ballast	Cum	0.11	0.17	0.28
6. Stone ballast	Cum	0.11	0.17	0.28
7. M.S. bars	Kg	7.00	8.00	12.00
Labor				
1. Mistri	Nos.	0.10	0.12	0.20
2. Mason	Nos.	1.25	1.50	2.50
3. Blacksmith	Nos.	0.22	0.33	0.45
4. Carpenter	Nos.	0.04	0.08	0.10
5. Bhisti	Nos.	0.30	0.34	0.50
6. Semiskilled labor	Nos.	2.00	2.80	4.00
7. Unskilled labor	Nos.	2.50	3.50	5.50

Table 18.
Materials and labor required for conversions of a bucket latrine
with leach pits under footpath

Item	Unit	Quantity		
		5-user	10-user	15-user
Materials				
1. Bricks	Nos.	480	640	870
2. Cement	Bags	2.75	3.75	5.50
3. Local sand	Cum	0.30	0.37	0.55
4. Coarse sand	Cum	0.11	0.15	0.21
5. Brick ballast	Cum	0.07	0.07	0.18
6. Stone ballast	Cum	0.17	0.24	0.37
7. M.S. bars	Kg	2.60	5.20	6.00
8. 24 gauge chicken wire-mesh	m ²	1.20	1.50	1.70
Labor				
1. Mistri	Nos.	0.10	0.15	0.23
2. Mason	Nos.	1.50	1.75	2.75
3. Blacksmith	Nos.	0.20	0.30	0.40
4. Carpenter	Nos.	0.08	0.12	0.18
5. Bhisti	Nos.	0.31	0.41	0.60
6. Semiskilled labor	Nos.	2.60	3.75	5.25
7. Unskilled labor	Nos.	3.50	5.00	7.50

Table 19
Materials and labor required for conversion of a bucket latrine
with leach pit under road

Item	Unit	Quantity		
		5-user	10-user	15-user
Materials				
1. Bricks	Nos.	580	720	930
2. Cement	Bags	3.75	4.50	5.75
3. Local sand	Cum	0.25	0.32	0.50
4. Coarse sand	Cum	0.25	0.26	0.30
5. Brick ballast	Cum	0.07	0.07	0.18
6. Stone ballast	Cum	0.27	0.30	0.36
7. M.S. bars	Kg	14.00	15.00	16.00
8. 24 gauge chicken wire-mesh	m ²	1.20	2.10	2.00
Labor				
1. Mistri	Nos.	0.15	0.16	0.22
2. Mason	Nos.	1.75	2.00	3.00
3. Blacksmith	Nos.	0.25	0.55	0.62
4. Carpenter	Nos.	0.13	0.15	0.17
5. Bhisti	Nos.	0.40	0.48	0.62
6. Semiskilled labor	Nos.	3.50	4.00	5.50
7. Unskilled labor	Nos.	4.00	6.00	8.00

Table 20.
Materials and labor required for construction of a new latrine
with leach pits within premises

Item	Unit	Quantity		
		5-user	10-user	15-user
Materials				
1. Bricks	Nos.	470	600	850
2. Cement	Bags	2.70	3.30	5.30
3. Local sand	Cum	0.35	0.42	0.65
4. Coarse sand	Cum	0.06	0.10	0.15
5. Brick ballast	Cum	0.19	0.19	0.38
6. Stone ballast	Cum	0.11	0.17	0.28
7. M.S. bars	Kg	7.00	8.00	12.00
Labor				
1. Mistri	Nos.	0.10	0.12	0.20
2. Mason	Nos.	1.50	1.75	2.75
3. Blacksmith	Nos.	0.23	0.30	0.46
4. Carpenter	Nos.	0.04	0.07	0.12
5. Bhisti	Nos.	0.32	0.42	0.62
6. Semiskilled labor	Nos.	2.50	3.25	4.50
7. Unskilled labor	Nos.	3.25	4.25	6.00

Table 21.
Materials and labor required for construction of a new latrine with
leach pits under footpath

Item	Unit	Quantity		
		5-user	10-user	15-user
Materials				
1. Bricks	Nos.	580	740	970
2. Cement	Bags	3.20	4.00	5.80
3. Local sand	Cum	0.38	0.47	0.65
4. Coarse sand	Cum	0.11	0.15	0.21
5. Brick ballast	Cum	0.13	0.13	0.25
6. Stone ballast	Cum	0.17	0.24	0.37
7. M.S. bars	Kg	2.60	5.20	6.00
8. 24 gauge chicken wire-mesh	m ²	1.20	1.50	1.70
Labor				
1. Mistri	Nos.	0.12	0.16	0.25
2. Mason	Nos.	1.75	2.00	3.00
3. Blacksmith	Nos.	0.20	0.31	0.43
4. Carpenter	Nos.	0.08	0.12	0.18
5. Bhisti	Nos.	0.36	0.46	0.65
6. Semiskilled labor	Nos.	2.75	4.00	5.75
7. Unskilled labor	Nos.	4.00	5.50	7.75

Table 22.
Materials and labor required for construction of a new latrine
with leach pits under road

Item	Unit	Quantity		
		5-user	10-user	15-user
Materials				
1. Bricks	Nos.	680	820	1030
2. Cement	Bags	4.25	5.00	6.00
3. Local sand	Cum	0.33	0.40	0.58
4. Coarse sand	Cum	0.25	0.26	0.30
5. Brick ballast	Cum	0.13	0.13	0.25
6. Stone ballast	Cum	0.27	0.30	0.36
7. M.S. bars	Kg	14.00	15.00	16.00
8. 24 gauge chicken wire-mesh	m ²	1.20	2.10	2.00
Labor				
1. Mistri	Nos.	0.16	0.20	0.25
2. Mason	Nos.	2.00	2.50	3.25
3. Blacksmith	Nos.	0.25	0.55	0.62
4. Carpenter	Nos.	0.13	0.15	0.17
5. Bhisti	Nos.	0.50	0.52	0.66
6. Semiskilled labor	Nos.	3.50	4.50	6.00
7. Unskilled labor	Nos.	4.50	6.25	8.25

DRAFT FORMS

Forms attached here are only drafts and models. These may be amended suitably to suit the requirements of a local authority. Since the agreement is a legal document, the local authorities are advised to have it examined by their legal adviser. After necessary modifications and amendments, the forms may be printed for smooth and expeditious implementation of the latrine program.

Form No. 1

NOTICE

A scheme for constructing pour-flush water-seal latrines has been introduced in the town. The latrine proposed is water flushed, free from flies and foul smell; it is sanitary and has been found to work satisfactorily in different parts of this country. Under this scheme, the existing dry/bucket/service latrines can be converted into pourflush water-seal ones and new ones can be constructed in households where no latrines exist at present, provided space is available in the premises of the house. The present day cost of conversion of a 5- and 10-user latrine as per standard design and drawing is Rs. and Rs. respectively with leach pits located within premises, while for a new latrine it will be Rs. more. Funds on the basis of standard designs, drawings and estimates are provided by the Municipal Board in the shape of % grant and % loan. The loan amount is repayable in monthly instalments of Rs. in years at % rate of interest. However, the cost of additional works, if any, will have to be borne by the houseowner. The local authority has already licensed a number of contractors who have been specifically trained for this purpose. The work can be done to the satisfaction of the houseowner through any one of the following contractors after getting the necessary formalities completed. The contractor will provide the necessary assistance.

Name	Address
1.	
2.	
3.	
4.	
5.	

Those who are interested in getting a latrine of the above type constructed in their households may please apply to the local authority on the application form which can be obtained from the office of the local authority.

The local authority shall provide the pit emptying service free of cost to the householders if they so desire, but in that case, the humus removed from the leach pits shall be the property of the local authority.

For more details kindly contact the office of the local authority.

Executive Officer/Commissioner
Local Authority

Form No. 2

Application by the house-owner for *the Conversion into/*the Construction of a Pour-Flush Latrine

From _____

To,
Municipal Commissioner/Executive Officer/Secretary,
.....
.....

Sub: *Conversion of dry or bucket latrine into pour-flush unit/*construction of a new pour-flush latrine with on-site disposal of excreta

Dear Sir,

I am to inform you that I am the owner of the house No. situated in locality of Ward No. in town. I am interested in getting (i) *my dry or bucket latrine converted to a pourflush one/(ii)*a new pour-flush latrine constructed as I do not have any latrine in my above mentioned house, as per design and drawing and on the terms and conditions specified by the Municipal Board. The number of persons residing in the household are I am willing to complete all the formalities required for the work.

*(i) I would like to get the work done through the licensed contractor, Shri.....

*(ii) The local authority may please get the work done through any of its licensed contractors.

It is requested that sanction to pay Rs as subsidy and Rs. as loan may kindly be accorded. An amount of Rs..... for the stamp paper for executing the agreement *is being sent/*has been deposited in the municipal office vide receipt No. dated

Yours faithfully,

(Signature of the house-owner)

*Please delete that which is not applicable.

Form No. 3

Application by the Tenant for the *Conversion/*Construction of a Pour-flush Latrine.

From,

To,

The Municipal Commissioner/Executive Officer/Secretary

Dated

Sub: *Conversion of dry or bucket latrine into pour-flush unit/*Construction of a new pour-flush latrine with on-site disposal of excreta.

Dear Sir,

I am to inform you that I am a tenant in house No. situated in locality of Ward No., whose owner is (name) (address)

I am interested in getting *(i) my dry or bucket latrine converted into a pour-flush unit *(ii) a new pour-flush latrine constructed as there is no latrine in my household, as per design and drawing and on the terms and conditions specified by the local authority. The number of persons residing in the household are The owner has given his concurrence for this work to be done at my cost (enclosed).* The owner has not given his concurrence for this work.* I am willing to complete all the formalities required for the work and to repay the loan instalments regularly.

It is requested that sanction to pay Rs. as subsidy and Rs. as loan may kindly be accorded. An amount of Rs. for the stamp paper for executing the agreement* is being sent/*has been deposited in the municipal office vide receipt No. dated

Yours faithfully

(Signature of the tenant)

*Please delete that which is not applicable.

Form No. 4

**Recommendation of the Technical Authority
of the Implementing Agency**

I have inspected the site. The applicant desires to get *(i) his dry/bucket latrine existing in house No. situated in locality converted into a pour-flush unit, *(ii) a new pour-flush latrine constructed in his house No. situated in locality as he does not have any latrine in his house.

The layout for latrine and leach pits is as enclosed. *No additional work is involved and the latrine will be *converted or *constructed as per standard design and drawing.

*The following additional works over the standard design, drawing and estimates are involved:

(i) Details of additional works

(ii) Cost of additional works

The leach pits *will be constructed within the premises of the aforesaid building *will have to be located under the *footpath or *road.

The applicant may be requested to deposit an additional amount of Rs. The leach pits constructed will be of user size. The cost of latrine with leach pits including cost of additional works and engineering charges will be Rs.

Dated signature of the Technical Authority

Proposal approved. *Certificate for locating leach pits under the *footpath/*road enclosed.

(Dated signature of sanctioning Authority)

*Please delete that which is not applicable.

Form No. 5

**Certificate of the Municipal Commissioner/Executive
Officer/Secretary of the Local Authority for
Locating the Leach Pits under the
Foot-path or Road**

I am fully satisfied and convinced that the leach pits of the proposed pour-flush latrine cannot be located within the premises of house no situated in locality owned by (name) (address) where the pour-flush latrine will be constructed. I, therefore, hereby accord my permission to locate the pits under the *foot-path/*road for the above mentioned premises.

Dated Signature of the
Municipal Commission/Executive office/Secretary

*Please delete that which is not applicable.

Form No 6

Sanction by the Municipal Commissioner/Executive
Officer/Secretary

From,

The Municipal Commissioner/Executive Officer/Secretary,

To,

No.

Dated

Sub: Sanction for the *construction of a pour-flush latrine/*conversion of dry latrine to pour-flush unit and sanction of subsidy and loan for the purpose.

Dear Sir,

I am to inform you that your application, dated for the conversion of your dry/bucket latrine into a pour-flush unit or *construction of a pour-flush latrine has been found in order. The sketch of layout plan is enclosed for your information. *The work will be done as per standard design in drawing. *The work involves some additional works as given below, cost of which is estimated to be Rs. kindly deposit this amount in the office of the Local Authority.

Details of additional works:

This sanction is subject to the condition that if any dispute arises, regarding the ownership of the land where the latrine will be constructed, you will be responsible for any loss or damage that may accrue.

I am sending this sanction in duplicate along with three copies of agreement forms including the original one on stamp paper. Kindly return the duplicate copy of the sanction along with the three copies of the agreement duly signated and witnessed.

Yours faithfull,

Municipal Commissioner/Executive
Officer/Secretary

Encl: as above

*Please delete that which is not applicable.

Form 6 (continued)

Returned the duplicate copy of the sanction in original to the Municipal Commissioner Executive Officer, Municipal Board with the remark that I have deposited Rs. in the office of the municipal vide receipt No. dated to meet the cost of additional works. I am also enclosing three copies of the agreement forms duly signed. Kindly direct the contractor to take up the construction immediately.

(Dated signature of the applicant)

Municipal Commissioner

Agreement examined and found in order. Verified that the cost of additional works has been deposited by the Local Authority. Kindly sanction the construction.

Construction sanctioned. Please ask the contractor to take up the work.

(Dated signature of the Technical Authority).

(Dated signature of the Municipal Commissioner/Executive/Secretary of the Local Authority)

Form No. 7

**Loan agreement between the Local Authority
and the Borrower**

An agreement made the day of 19..
between the local Authority,
(hereinafter called 'the Authority' which expression shall include its
successors and assigns wherever the context or meaning shall so require or
permit) of the one part, and (hereinafter called 'the
beneficiary' which expression shall include his successors and assigns
wherever the context or meaning shall so require or permit) of the other
part.

Whereas

- (a) The beneficiary desires to convert his existing
dry/bucket latrine to pour-flush water-seal latrine
with leach pits with on-site disposal of excreta
(hereinafter called latrine) or to construct a new
pour-flush water-seal latrine in house No.
situated in locality of Ward
No. owned by the beneficiary or
(actual owner).
- (b) The beneficiary desires to have a sum of Rs.
as loan and Rs. as grant for the aforesaid
latrine from the Authority, and the Authority has
acceded to the said request of the beneficiary.

It is hereby agreed and declared as follows:--

- (i) That the beneficiary has received the amount of Rs. as
subsidy and Rs. as loan from the Authority, the
stamped receipt of which is enclosed.
- (ii) That the beneficiary has seen the standard designs and
drawings of the latrine available in the office of the
Authority, and has selected one of them to be constructed in
his house, cost of which is Rs. including
supervision charges.

- (iii) That due to site conditions some additional works to the standard design and drawing are required, cost of which as estimated by the Authority is Rs., which has been deposited by the beneficiary with the Authority vide Receipt No., dated
- (iv) That the beneficiary has agree to have the work executed through the Authority/through the licensed contractor of his choice and has deposited the aforesaid amount of Rs. with the Authority vide receipt No., dated
- (v) That the beneficiary authorizes the Authority to make the payment to the contractor out of the aforesaid deposits after adjusting the supervision charges.
- (vi) That the amount of loan of Rs. is repayable in years with % rate of interest per annum, and the beneficiary will pay back the entire loan amount with interest to the Authority at an equated periodical instalment of Rs. The first instalment shall fall due on the first day of the next month to the month in which the latrine is constructed.
- (vii) That if the beneficiary pays the said instalment on or before the due date, he will be entitled to a rebate of % of the due instalment.
- (viii) That notwithstanding the stipulation regarding payment of periodical instalment contained in aforesaid paras, the beneficiary may repay the whole amount of the loan or a portion thereof and interest thereon at any time before the date on which the loan or any instalment thereof or interest thereon falls due for payment but any repayment made in pursuance of this sub-clause shall be adjusted against interest due and the balance, if any, towards the principal.
- (ix) That if any instalment of principal or interest or both shall remain unpaid on the due date thereon; the Authority, without prejudice to its rights, will have a right to recover the dues of latrine loan in the same way as arrears of municipal taxes are realized; and also the Authority will have a right to disconnect the water supply pipe connection of the house of the beneficiary.

If any such instalment of principal or interest, or both, that may become due and payable to the Authority shall remain unpaid for more than 30 days from the respective due dates thereon, penal interest at the rate of % shall be payable from the due date.

Form No. 7 (continued)

- (x) That if the owner beneficiary sells or the tenant beneficiary vacates the property, he shall give such information to the Authority in advance and the entire balance amount of principal and interest of the latrine loan which has remained unpaid on that date shall be payable back without prejudice to the Authority's right to recover the same from his successors and assigns.

In witness whereof the parties hereto have signed this deed on the day and year first above written.

Singed by: _____

Signed by: _____

For and on behalf of the Local Authority
Witness (with complete address)

The Borrower
Witness (with complete address)

1

.....

.....

.....

1

.....

.....

.....

2.

.....

.....

2

.....

.....

Form No. 8

Work order and Intimation to House-owner

From:

The Municipal Commissioner/Executive Officer/Secretary,
.....
.....

To:

The Contractor,
.....
.....

No.

Dated

Sub: *Construction of a pour-flush latrine/*conversion of dry latrine into
pour-flush unit-work order.

Dear Sir,

Kindly take up the *construction of a pour-flush
latrine/conversion of a dry latrine into a pour-flush unit in house
No. situated in local and owned by
(name) address The
construction will be done as per layout given by the technical authority at
site and as per design, drawing and specifications prescribed by the Local
Authority.

*The construction will be done as per standard design and drawing
and no additional work is involved. The cost would therefore be Rs.
which will be paid to you.

*The following additional works over the standard drawing are
also involved, which will cost Rs.This will be paid extra over
the standard cost; thus a total of Rs. will be paid to you.

Details of additional works

After completion of the works, please furnish the certificate of
satisfactory completion in duplicate duly signed by the house-owner.

Yours faithfully,

(Municipal Commissioner
Executive Officer/Secretary).

Encl: as above

*Please delete that which is not applicable.

Form No. 8 (continued)

Copy forwarded to (name and address of houseowner)
.....for information and
necessary action. The layout plan has already been sent to him. A copy of
standard drawing and design is enclosed. He is requested to keep watch on
the construction to see that it is done to his satisfaction according to
enclosed details and specifications. After the satisfactory completion of
the work, kindly return the certificate of satisfactory completion duly
signed.

A copy of the agreement is enclosed for his record. A pamphlet
giving important instructions regarding operation and maintenance of a
pour-flush latrine is also enclosed. The instructions should be read and
strictly followed. Record of pit use, filling and emptying should also be
kept.

Municipal Commissioner
Executive Officer/Secretary

Details of construction and specifications .

1. Sketch of layout plan (already sent)
2. A copy of standard drawing & design (enclosed)
3. Size of pit:
 - (a) Number of pits 2
 - (b) Internal diameter of pits --
 - (c) Depth of pits from the ground level --
 - (d) Clear distance between the pits --
4. Following materials will be supplied to the contractor by the local authority:
 - (a) Ceramic/GRP pan 425 mm 1 No.
 - (b) Ceramic/GRP/HDPE trap of 70 mm dia with 20 mm waterseal 1 No.
 - (c) Mosaic/ceramic/glass-fiber footrests 1 pair
 - (d) 75 mm dia AC non-pressure pipe - metre
 - (e) RCC slabs for covering the pits 2 Nos.
 - (f) RCC slab for covering the chamber 1 No.
 - (g) Cement - Bags

5. Specifications

- (a) The pits shall be lined with 75* or 115* mm thick brick work in cement mortar 1:6 (one cement: six sand). At the bottom one layer of brick will be 225 mm wide and the top over the pipe about 300 mm in height will be solid and the rest will be honeycomb brickwork having *3" x 4 1/2" or *12 to 15 mm wide holes.

*Please delete that which is not applicable.

- (b) Flooring of the latrine shall be 22 mm thick cement concrete 1:2:4 (one cement: two coarse sand: four stone grit 6 mm to 10 mm size) over 75 mm thick cement concrete 1:6:12 (1 cement: 6 sand: 12 brick ballast 40 mm size graded). Top layer shall be 3 mm thick and will be of 4 cement to 1 marble dust or coarse sand, and shall be finished smooth with neat cement.
- (c) Cement used on the work will be bags.
- (d) First-class brick used in the work will be nos.
- (e) Curing of flooring and masonry work will be done for 7 and 10 days respectively.
- (f) RCC slab should be placed over the pits and fixed with cement mortar 1:6 to make it airtight, the top level being higher than the surrounding ground and sloped to prevent the stagnation of any surface water near the pits.
- (g) Drain connecting the trap and pits should have 25 mm thick cement concrete 1:2:4 at the bottom and sides plastered in cement mortar 1:4 (1 cement: 4 coarse sand). The bottom and insides of drain should be made smooth with neat cement. The drain shall be covered with flat bricks. Drain shall project 100 mm into the pits;
- The pits shall be connected by 75 mm dia pipe and a chamber 250 mm x 250 mm internal size shall be constructed at the junction point from where two pipes will be provided to connect the pits. The mouth of the pipes should project 100 mm in length into the pits.
- (h) Before covering the drain, one of the two branches should be blocked so that the discharge from the trap goes into one pit only.
- (i) Site will be cleared.

Form No. 9
Completion Certificate

COPY FOR CONTRACTOR
(Completion Certificate)

As per your work order No. dated, I have completed the *conversion of dry or bucket latrine with a pour-flush unit/*construction of a new pour-flush latrine in house No..... situated in Ward No.... as per design, drawing, specifications and layout given to me.

Dated signature of contractor

The Contractor (name).....
(address)

has completed the *conversion of my dry or bucket latrine into a pour-flush unit/*construction of a new pour-flush latrine in my house No..... situated in locality. I am fully satisfied with the work done by him.

Dated signature of the beneficiary

*Please delete the portion not applicable.

COPY FOR ACCOUNTANT
(Completion Certificate)

As per your work order No..... dated....., I have completed the *conversion of dry or bucket latrine with a pour-flush unit/*construction of a new pour-flush latrine in house No..... situated in Ward No..... as per design, drawing, specifications and layout given to me.

Dated signature of contractor

The Contractor (name).....
(address)

has completed the *conversion of my dry or bucket latrine into a pour-flush unit/*construction of a new pour-flush latrine in my house No..... situated in locality. I am fully satisfied with the work done by him.

Dated signature of the beneficiary

*Please delete the portion not applicable.

COPY FOR LOAN RECOVERY
(Completion Certificate)

As per your work order No..... dated, I have completed the *conversion of dry or bucket latrine with a pour-flush unit*/ construction of a new pour-flush latrine in house No..... situated in Ward No..... as per design, drawing, specifications and layout given to me.

Dated signature of Contractor

The Contractor (name)
(address)

has completed the *conversion of my dry or bucket latrine into a pour-flush unit/*construction of a new pour-flush latrine in my house No..... situated in locality. I am fully satisfied with the work done by him.

Dated signature of the beneficiary

*Please delete the portion not applicable.

I have verified that the above certificate has been signed by the beneficiary. I have inspected the aforesaid work. I certify that the above work has been completed as per given design, drawing, specifications and layout. Payment amounting to Rs. (amount in words) may be made to the contractor.

I have verified that the above certificate has been signed by the beneficiary. I have inspected the aforesaid work. I certify that the above work has been completed as per given design, drawing, specifications and layout. Payment amounting to Rs. (amount in words) may be made to the contractor.

Dated signature of the Junior Engineer.

Dated signature of the Junior Engineer.

Counter signed
(Municipal Engineer)

Counter signed
(Municipal Engineer)

Accountant
Payment may please be made to the contractor.

Loan Recovery Section
Please start loan recovery from the owner of the house from next month.

Municipal Commissioner/Executive Officer/Secretary

Form No. 10**Instructions for the Operation and Maintenance
of Pour-Flush Latrines**

1. Before using the pan of the latrine, pour a little water over the pan to wet it, so that the excreta, when it falls, slide smoothly without sticking to the surface.
2. A container of 1.5 to 2 liters capacity should be kept in the latrine. It should be kept filled with water at all times; and after each use of the latrine, water from the container should be poured in the pan for flushing the excreta. If excreta sticks to the pan, some more water should be poured on the specific spots to wash out those particles. Excreta should not be visible in the trap. If excreta is there, pour about one more liter of water. The quantity of water used for flushing should be just sufficient to flush the excreta. Use of excess quantity of water should be avoided.
3. No water-tap should be provided in the latrine. Water for flushing should be accessible, but the possibilities of continuous dripping or leaking are to be avoided.
4. Rainwater, wastewater from bath, kitchen, etc., should not be allowed to enter the pan or the leach pits.
5. The pan should be cleaned daily with a broom or brush with a long handle after sprinkling a small quantity of water and soap powder. The latrine floor may be washed daily but with the least amount of water, otherwise the life of the pits will be affected.
6. To avoid choking of the pan and trap, no waste (such as kitchen waste, sweepings, rags, cotton pieces, etc.) should be thrown in the pan.
7. Lighted cigarette butts should not be thrown in the pan, as they will stain it.
8. In case any construction defect is noticed within a year of latrine construction, the matter should be reported to the Municipal Board immediately.
9. If the pan or trap gets choked, rodding should be done from the pan side as well as from the rear side by means of a split bamboo stick. However, if the choking is not cleared, the matter should be referred to the Municipal Board immediately.

Form 10 (continued)

10. Only one of the two leach pits should be used at a time. After about three years or whenever the first pit is full, the discharge from the pan should be diverted to the second pit and the first pit should be allowed to rest. The operation of diversion of discharge to the second pit can be undertaken by the householder or he can make his own arrangements to have it done for him. This can be done by blocking one of the branches of the drain; and in the case of pipes by blocking the mouth of one of the pipes in the junction chamber. When the first pit has been out of use for about two years, it should be emptied, by the householder himself or through the Municipal Board. After the pit is emptied, the RCC cover should be placed in position again. The humus, which has manurial value, may be utilized as a manure in the kitchen garden or in the fields. (If the Municipal Board provides emptying service free of charge, the humus will be the property of the Board.) When the second pit is full, the first pit should be used, by diverting the discharge from the second to first pit. Record of date regarding use, diversion to second pit and emptying the pit should be kept in a chart given at the back page of these instructions.

11. If foul odor comes from the pit or the pan, it means that the pit cover is not air tight or the waterseal has broken in the trap. The pit cover should be made air tight, and if a foul smell is coming from the pan, a small quantity of water may be poured to provide the necessary waterseal.

**Chart showing the dates when the pits were put
to use/allowed to rest/and were emptied
(Month and Year)**

	1st time	2nd time	3rd time	4th time	5th time
1. When the first pit was put to use	_____	_____	_____	_____	_____
2. When the first pit was filled and allowed to rest	_____	_____	_____	_____	_____
3. When the first pit was emptied	_____	_____	_____	_____	_____
4. When the second pit was put to use	_____	_____	_____	_____	_____
5. When the second pit got filled and allowed to rest	_____	_____	_____	_____	_____
6. When the second pit was emptied	_____	_____	_____	_____	_____

Form No. II
Guarantee Card

The local authority, takes the responsibility of setting right free of cost any construction defect that may develop, except due to natural calamities, misuse or negligence of the owner or the users, in the pour-flush latrine within one year of its construction by (contractor on (date) in house No. situated in locality and ward No... owned by (name) (address) on receipt of written complaint.

Municipal Commission
Executive Officer/Secretary,
Local Authority

Note - Please keep this card safely. For rectifying the construction defects this card will have to be presented before the local authority. If this card is lost or destroyed, a duplicate will be issued on receipt of request against a payment of Rs. 5.

**Draft Model By-Laws for Regulating
the Construction, Operation,
Maintenance and Control of Latrine**

In exercise of the powers vested under Section of (State) Municipalities Act, (year), the Municipal Board of (Town) hereby makes the following By-laws for regulating the construction, maintenance and control of water-flush latrines within its areas.

By-Laws

1. Short Title, Extent and Commencement

- (a) the By-Laws may be called the (town) Municipal Board latrine by-laws.
- (b) They shall extend to the whole of Municipality of
- (c) They shall come into force three months from the date of their publication in the Official Gazette.

2. Definitions

- (a) "Municipal Board" includes Municipal Corporation, Municipal Council, Town Area Committee, Notified Area Committee and Nagar Panchayat.
- (b) "Executive Officer" includes Commissioner, Chief Officer and Secretary.
- (c) "Latrine" or "Privy" means a place set apart for defecation together with the structure comprising such place, the receptacle therein for human excreta and the fittings and apparatus, if any, connected therewith, and includes a dry latrine and a water-flush waterseal latrine.
- (d) "Dry Latrine" means a latrine in which human excreta are discharged into any type of receptacle, e.g., bucket, etc., or otherwise and required to be removed by human agency.
- (e) "Waterseal latrine" means a latrine with a minimum waterseal of 20 mm in which excreta is pushed in or flushed by water and not required to be removed by human agency. The types, designs and specifications of various kinds of water-seal flush latrines shall be as given in the schedule of these By-laws or as may be prescribed by the State Government from time to time.

3. Preparation of a Register Regarding Latrines

The Executive Officer shall prepare and maintain a register of Households containing information about the existing position of latrine facilities, their types and number of users etc., where such facilities exist, in such form as may be prescribed. For collecting necessary information in this regard, the Executive Officer may, by requisition, require the owner or occupier to furnish the same within the period specified therein who shall be bound to furnish such information.

4. Construction of New Latrines

After these by-laws are in force:

- (a) Any latrine that may be constructed by any person shall be of waterseal type, conforming to the types, designs and specifications prescribed in the by-laws.
- (b) Every person who builds or rebuilds a residential building shall provide at least one waterseal latrine in it.
- (c) Every household shall have at least one waterseal latrine and in case the number of users within a household exceeds 10, it shall have at least two latrines; and
- (d) No building plan of any type of construction, or alterations or additions to a building, shall be sanctioned and no building shall be deemed to have been completed and fit for human occupation unless provision is made for a waterseal latrine, and the dry latrine, if any, is dismantled; but if the number of users in the household exceeds 10, at least two waterseal latrines shall be provided.

5. Location of the Units

- (a) No leach pit for disposal of excreta shall be located within a radius of 8 m from an existing hand pump or well unless special precautions to the satisfaction of the Executive Officer are taken. However, in soils with grain sizes less than 1 mm and where maximum groundwater level throughout the year is more than 2 m below the pits, the leaching pits can be located at 3 m distance from drinking water sources.
- (b) Leach pits shall be located within the premises of the building where the new or converted latrine is proposed to be constructed; where this is not possible, the pits can be located under the footpath, road or street. The final authority to determine this feasibility shall be the Municipal Board, and its decision shall be final and binding. Permission to build the leach pits under the road, street or footpath shall be given only by the Executive Officer or by the person authorized by him, when he is fully satisfied that it is not feasible to construct these pits within the premises of the building.

- (c) In case the leach pits are located under the road, street or footpath, the invert level of the pipe connecting the latrine pan with the pit shall be at least 1.1 m below ground level or below the bottom of the water main existing within a distance of 3 m from the pits, whichever is more.

6. Phased Latrine Program

The Municipal Board shall make out a reasonable time-bound phased program requiring the owners or occupiers of households to convert the existing dry/bucket latrines to waterseal units and to provide waterseal latrines in all the premises in different wards.

7. Notice for Construction/Conversion of Latrine

The Executive Officer shall issue a notice in writing to the owner or occupier to provide a waterseal latrine or latrines in the premises with no latrine, or an additional unit or units in households with inadequate number of latrines and or to convert the existing dry latrine into a waterseal one as per prescribed specifications within three months from the date of service of notice. The period of three months may be extended by the Executive Officer at the request of the owner or the occupier if sufficient reasons justifying the grant of such request are shown, provided that the total period shall not exceed six months in aggregate from the date of service of such notice.

In case, due to space constraints, it is not feasible to convert or build a new latrine as specified in the schedule of these By-laws, the owner or occupier shall inform the Municipal Board about it, but to determine the aforesaid feasibility the final authority shall be the Municipal Board and the decision of the Board shall be final and binding on the owner or the occupier of the building.

8. Licensed Contractors for Construction of Waterseal Latrines

The Municipal Board shall issue licences to technicians, contractors and plumbers in sufficient number (who are trained and, in the opinion of the Municipal Board, competent to undertake the work of construction of waterseal latrines conforming to the prescribed specifications, types and designs etc.) on payment of a licence fee of Rs. 25, and the Municipal Board shall maintain a register thereof for the convenience of the persons constructing the waterseal latrine.

No other person except the licensed contractors shall be allowed to construct waterseal latrines. An agreement shall be executed between the Municipal Board and the licensed contractor laying down the relevant terms and conditions, and necessary security money must be deposited with the Municipal Board.

9. Application and Other Procedures

- (a) The person desirous of converting or constructing a latrine shall submit an application on the prescribed form to the Municipal Board for sanction giving all necessary details about the type,

design and specifications of the latrine proposed to be constructed and also giving the location of latrine, leach pits, etc. The licensed contractor will assist him in submitting the application and getting it sanctioned. When the application and proposal are found in order, the sanction will be accorded by the Municipal Board and a copy of the list of materials to be used and specifications of the work will be given to the applicant provided the applicant is constructing a pourflush waterseal latrine with twin leach pits. The Municipal Board has the right to refuse permission to build a new latrine or to convert the existing dry, bucket or borehole latrine, if there is a possibility of a public health hazard.

- (b) If a person who wants to convert an existing dry, earth, bucket or borehole latrine or build a new waterseal pourflush latrine with onsite excreta disposal requires financial assistance for it, he will execute an agreement with the Municipal Board in accordance with the scheme of financial assistance to the householders notified by the Municipal Board. The financial assistance will be a loan, or a mix of loan and grant. The criteria for determination of grant element and the terms and conditions for giving the financial assistance and loan recovery with interest shall be as notified by the Municipal Board or the State Government from time to time.
- (c) The licensed contractor shall construct the sanctioned latrine as per the prescribed design, drawing and specifications to the satisfaction of the Municipal board and the owner or the occupier of the house.
- (d) After the contractor submits the completion certificate for building the latrine, and the Municipal Board and the owner or the occupier of the building are satisfied with the construction, payment will be released to the contractor by the Municipal Board. The owner or the occupier of the building will be given detailed instructions and guidance as well as a pamphlet giving instructions and guidelines regarding its use, operation and maintenance.
- (e) The latrine constructed shall be provided with a superstructure with proper ventilation. If there is a scheme for giving financial assistance for constructing a superstructure, the person who constructs the latrine will be given financial assistance on execution of an agreement on terms and conditions as specified by the Municipal Board, provided funds are available with the Municipal Board.
- (f) A person who builds or rebuilds a house shall not be given any financial assistance by the Municipal Board for constructing a latrine.
- (g) The person who has obtained a loan for constructing a latrine or superstructure shall repay the loan with interest in regular instalments determined by the Municipal Board under the financial

assistance scheme. In case of default, the following measures will be taken for recovery:

- (i) Rate of interest from the date the last loan instalment paid to the date of payment of outstanding due loan amount shall be raised to at least 5% above the current bank loan interest.
- (ii) Recovery of loan dues with penal interest in case of default will be effected by means of distraining goods of the defaulter as is laid down for the recovery of tax in Section of the Municipal Act or through the District Magistrate as arrears of land revenue.
- (iii) The water pipe connection, if the defaulter has one in the house, may be disconnected.
- (iv) Recovery will be effected from the tenant, who will recover it from the rent paid to the owner of the house.
- (v) in case the owner of the building, in whose respect the default has accrued, is not living in the building, the water connection of the building where he is residing, if it lies within the municipal limits of the town, will be disconnected.

10. Dismantling of Dry Latrine

After the construction of a waterseal latrine, the dry latrine (if existing in the household where the waterseal latrine has been constructed) shall be dismantled.

11. Execution of Work by Municipal Board Payment

If owner or the occupier against whom a notice under By-law No. 7 above has been issued fails to comply with the notice within the specified time, then without prejudice to any other action that may be taken against him under any other provision of the law, the Executive Officer shall get the latrine constructed or converted, as the case may be, in terms of notice, departmentally or through any licensed contractor, and recover the expenses incurred in this regard from the defaulter under Section of the (State) Municipal Act (Year).

12. Maintenance of Latrine

The waterseal latrine shall be properly maintained and kept in sanitary condition by the owner or the occupier. The contents of the septic tanks, soak pits, leach pits, etc., shall be periodically emptied by the owner or occupier at his own cost, either through a private agency or the Municipal Board. The Municipal Board shall maintain a special squad for this purpose and provide services for emptying the contents and/or removal thereof. The leach pits will be cleaned only after they have been out of service for two years (after they were completely filled). If the Municipal Board cleans the leach pits free of cost at the request of the

owner or the occupier of the building, the humus shall be the property of the Municipal Board and the owner or the occupier of the house shall not have any claim on it.

13. Penalty for Breach

Any person committing breach of any of these by-laws shall be liable to a fine not exceeding Rs. 500.

LIST OF PUBLICATIONS BY
THE TECHNOLOGY ADVISORY GROUP (TAG)
UNDP INTERREGIONAL PROJECT INT/81/047

- WP/01 A Model for the Development of a Self-help Water Supply Program;
by Colin Glennie.
- WP/02 Ventilated Improved Pit Latrines: Recent Developments in Zimbabwe;
by Peter Morgan and D. Duncan Mara.
- TN/01 Methods for Gathering Socio-Cultural Data for Water Supply and
Sanitation Projects; by Mayling Simpson-Hebert.
- TN/02 Planning of Communication Support (Information, Motivation and Education)
in Sanitation Projects and Programs; by Heli Perrett.
- TN/03 The Ventilated Improved Double-Pit Latrine: A Construction Manual
for Botswana; by John van Nostrand and James G. Wilson.
- TN/04 Pit Latrine Ventilation: Field Investigation Methodology; by
Beverley Ryan and D. Duncan Mara.
- TN/05 Social Feasibility Analysis of Low-Cost Sanitation Projects; by
Heli Perrett.
- TN/06 Ventilated Improved Pit Latrines: Vent Pipe Design Guidelines; by
Beverley Ryan and D. Duncan Mara.
- TN/07 Community-Based Workshops for Evaluating and Planning Sanitation
Programs: A Case Study of Primary Schools Sanitation in Lesotho;
by Piers Cross.
- TN/08 Rural Ventilated Improved Pit Latrines: A Field Manual for Botswana;
by John van Nostrand and James G. Wilson.
- TN/09 Handbook for District Sanitation Coordinators; by Keadire Basaako,
Ronald D. Parker, Robert B. Waller and James G. Wilson.
- TN/10 Manual on the Design, Construction and Maintenance of Low-Cost
Pour-Flush Waterseal Latrines in India; by A.K. Roy