

**AT** MICROFICHE  
REFERENCE  
LIBRARY

A project of Volunteers in Asia

How to Make a Folding Machine for Sheet Metal Work

by: Rob Hitchings

Published by:

Intermediate Technology Publications, Ltd.  
9 King Street  
London WC2E 8HN  
United Kingdom

Paper copies are \$ 3.75.

Available from:

Intermediate Technology Publications, Ltd.  
9 King Street  
London WC2E 8HN  
United Kingdom

Reproduced by permission of Intermediate  
Technology Publications, Ltd.

Reproduction of this microfiche document in any  
form is subject to the same restrictions as those  
of the original document.

# How to make a folding machine for sheet metal work

Rob Hitchings

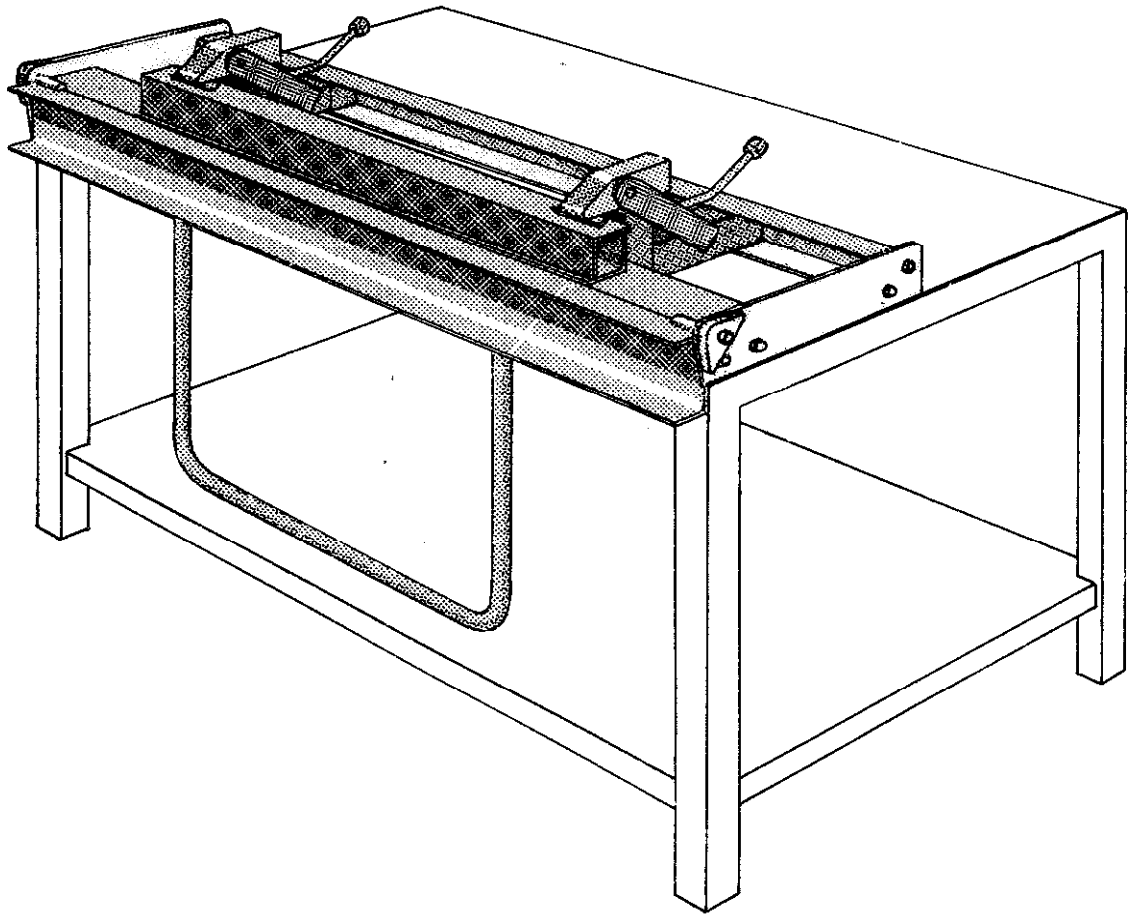

**This manual, *How to make a folding machine for sheet metal work*, gives full details on how to build and use a versatile machine for working sheet metal.**

Such a machine offers the increased facility of being able to readily produce items in sheet metal such as ducting, steel boxes, trays and agricultural equipment. It is equally useful for vehicle building and repair work.

Designed specifically for construction from readily available steel sections, the machine could be built by most small metal workshops and blacksmiths.

The ability to make locally, equipment for small farms and villages in rural areas, is being increasingly seen as very useful, both in the developing countries and in the more industrialized nations.

With the rising cost of fuel for transportation and growing awareness of the finite resources of the planet, it makes sense to encourage local self reliance and small-scale production of certain equipment.

The clear illustrations and step-by-step building instructions make this a very practical manual for any small workshop wishing to increase its capacity to fabricate in sheet metal.

**The Author** (who also illustrated and laid out the pages for this manual), has a background in 'practical' engineering and appropriate technology workshops. His business (ApT Design & Development), based in Cumbria (N.W. England), design and make village scale equipment for workshops both in the developing and industrialized countries.

Rob Hitchings is interested to hear from other designers/engineers who are building similar equipment around the world and hopes that a network of people may emerge who can share ideas and collaborate together to develop further designs.

Intermediate Technology Publications Ltd., 9 King St., London WC2E 8HN, England.

ISBN 0 903031 76 0

# **HOW TO MAKE A FOLDING MACHINE FOR SHEET METAL WORK**

**Designed and written by Rob Hitchings**

Step-by-step instructions on how to build a versatile machine for folding sheet metal to produce box sections e.g. ducting, and pans/trays etc. Includes detailed plans, operating instructions, and several design options.

Intermediate Technology Publications Ltd.

## Acknowledgements

Financial assistance in the final development of this machine as well as in the production of this booklet was made available through Intermediate Technology Industrial Services from a grant from the Overseas Development Administration. Their assistance is gratefully acknowledged.

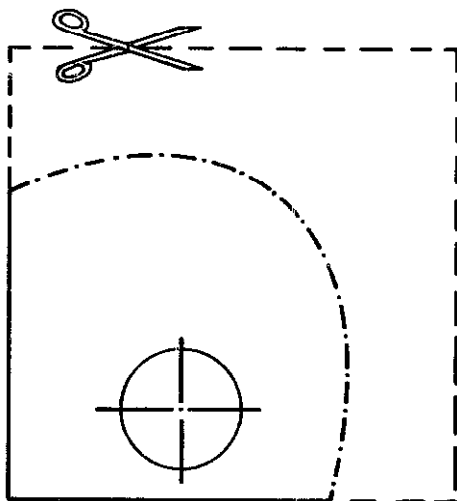

### Pattern for cam

refer to page 24

Cut out square.  
Tape on to metal.  
Centre punch through  
pattern on dots and  
pivot centre.

© Intermediate Technology Publications Ltd. 1981.  
9 King Street,  
London WC2E 8HN

ISBN 0 903031 76 0  
Printed by the Russell Press Ltd, Nottingham. U.K.

## **Introduction**

The sheet metal folding machine, the construction of which is described in detail in this booklet, is cheap to build and versatile in use. It can be made from readily-available channel, angle and hollow steel sections using basic welding and fabrication techniques. The only equipment essential to its construction is a drilling machine, an electric welder, G clamps and basic hand tools. An angle grinder, mechanical hacksaw and a flame cutter would make it easier, though these tools are not essential.

Construction can be modified to suit locally-available materials. The machine can be bolted on to a strong bench or mounted on a stand.

Once constructed, this machine will be found very useful in any small metal workshop to make objects in sheet metal such as boxes, trays, baking-pans, channels, air-ducts, chimney flues, funnels, cabinets; or agricultural equipment such as seed-hoppers, troughs, water and fuel tanks.

This folding machine should prove an invaluable tool in any small workshop in the industrialized countries, as well as in the Third World.

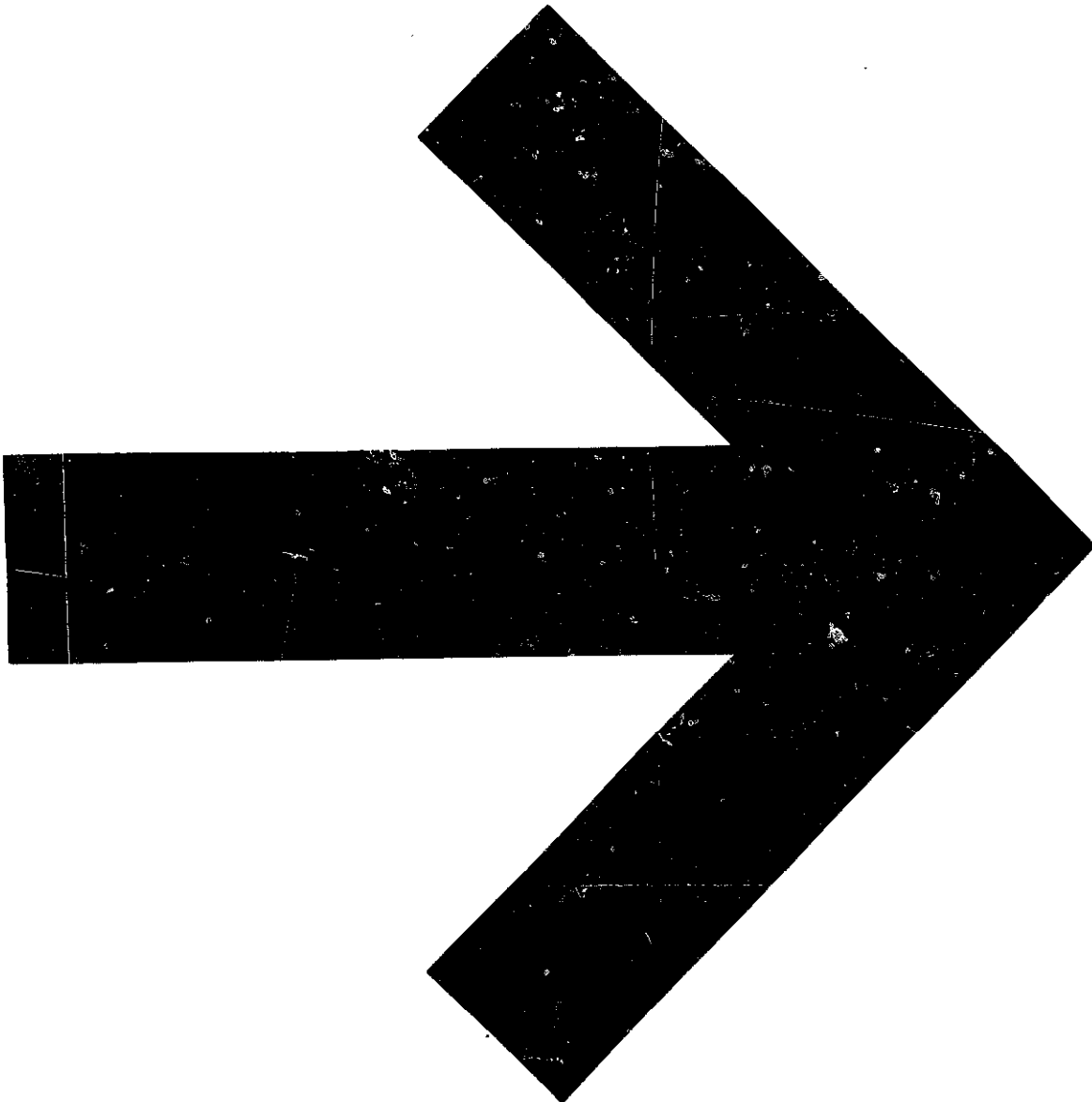

# Contents

	Page
Introduction	3
Uses of the machine	6
Description	7
Detail drawings of machine components	10
Construction	12
Operation	27
Optional designs	29



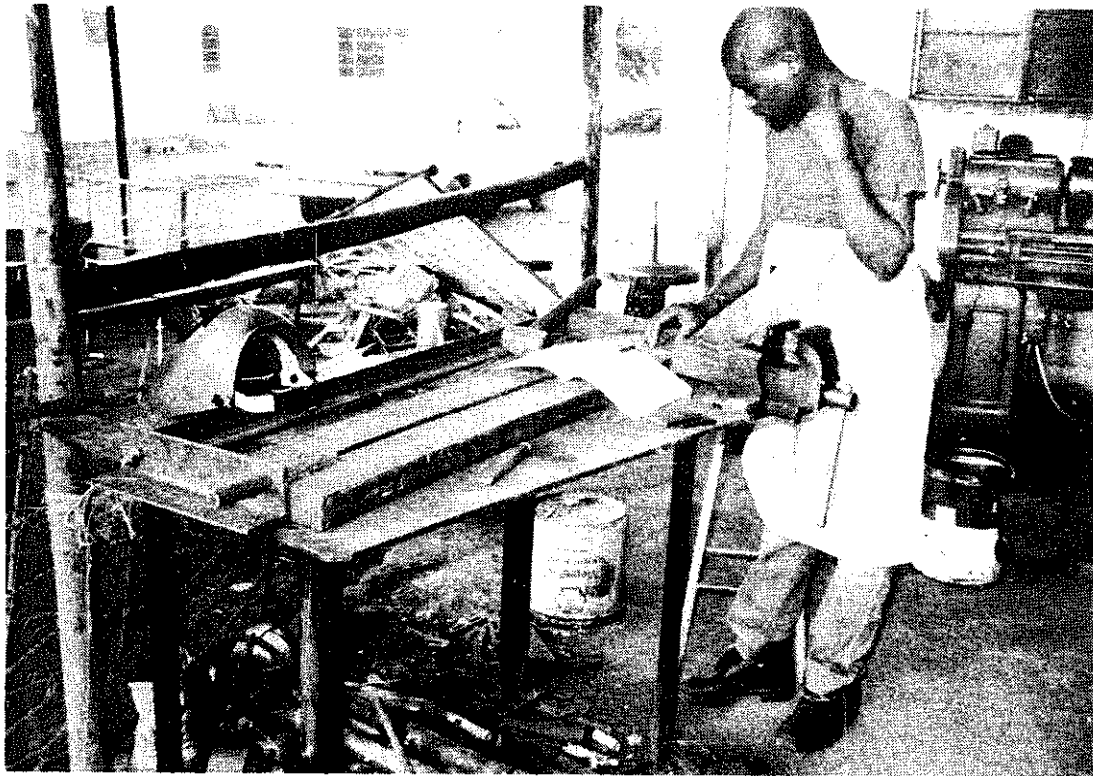

*Manufacturing and testing the machine in Botswana.*

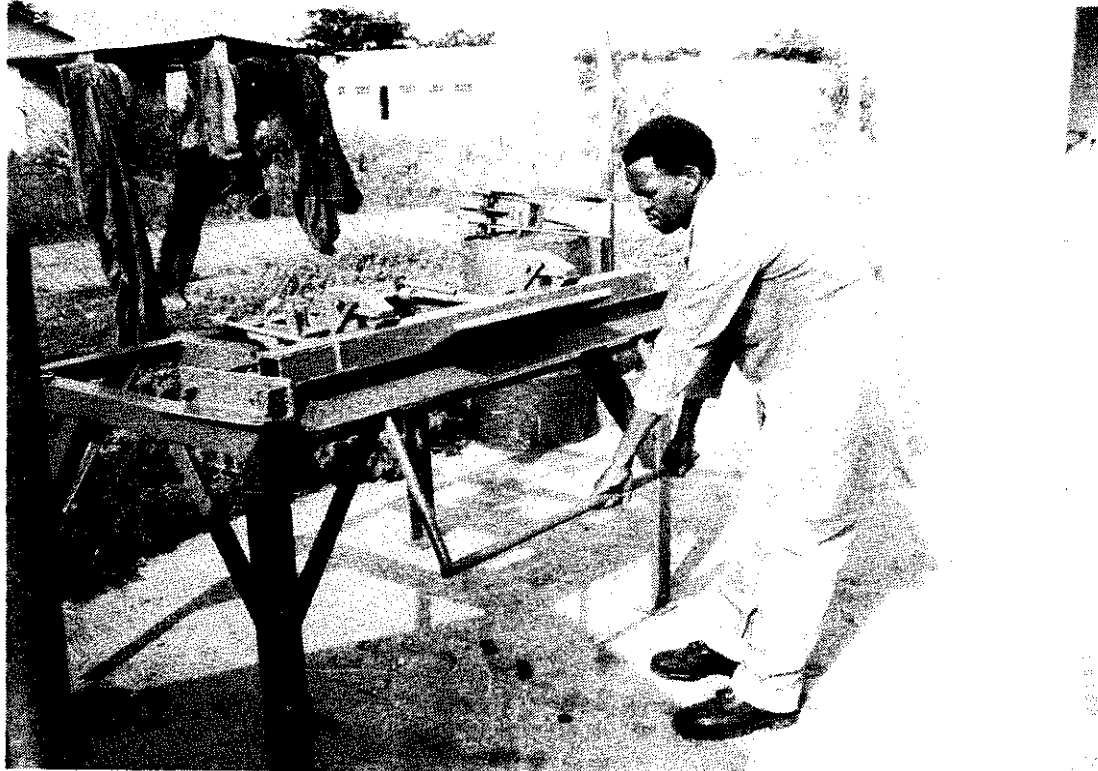

## Uses of the folding machine

The machine will bend steel sheet up to 16 guage (approx. 1.5mm thick) x 1 metre wide and can produce both box sections, and pans up to 100mm deep (150mm on modified machine).

Once the basic machine has been built it can be adapted in numerous ways to do almost any sheet metal folding job (within the capacity of the machine's strength). Several adaptations are suggested in the optional design section.

Some of the shapes and suggested items which this folding machine can produce are illustrated below.

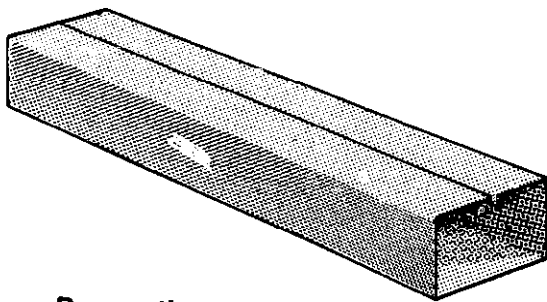

**Box sections:**  
air ducts, chimneys, structural work.

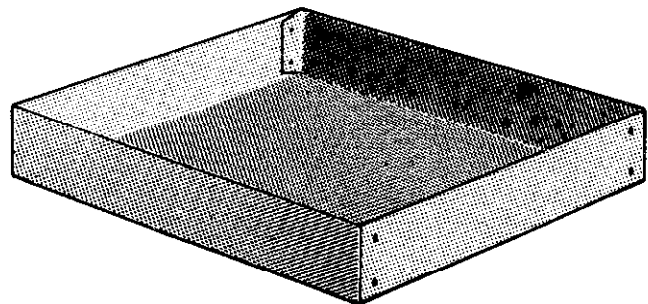

**Pans:**  
boxes, trays, lids, troughs, water/fuel tanks.

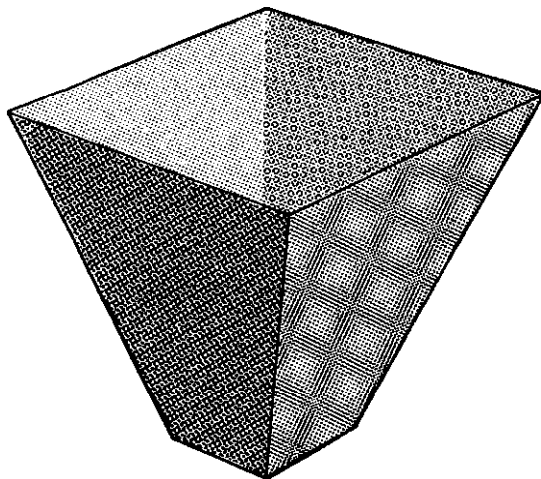

**Funnels:**  
Grain/seed hoppers etc.

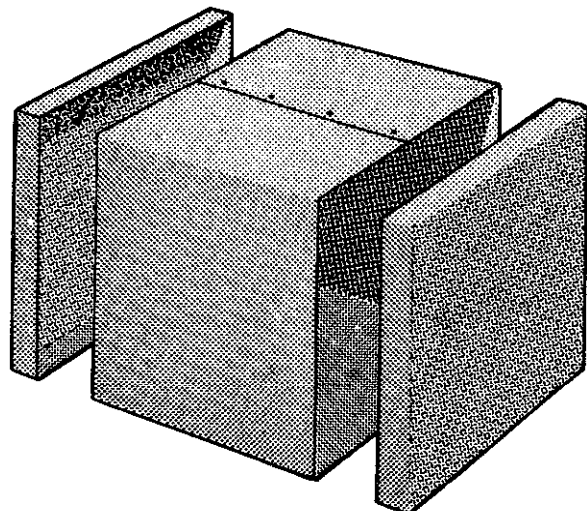

**Large boxes/tanks**

## Description

The machine comprises:

- The base frame assembly, which is suitably fixed down.
- Two clamp assemblies, which act on .....
- ..... the clamping beam, which clamps the sheet metal along the line that requires folding.
- The folding beam which is pivoted at each end. This has a handle which is raised and thus causes the clamped sheet metal to bend. The clamps slide from side to side to adjust to whatever width needed. Several clamping beams can be made to suit the widths of four-sided trays/pans required. This is not necessary for box sections (ducting), or for normal straight folds. In such cases the full width beam can be used.

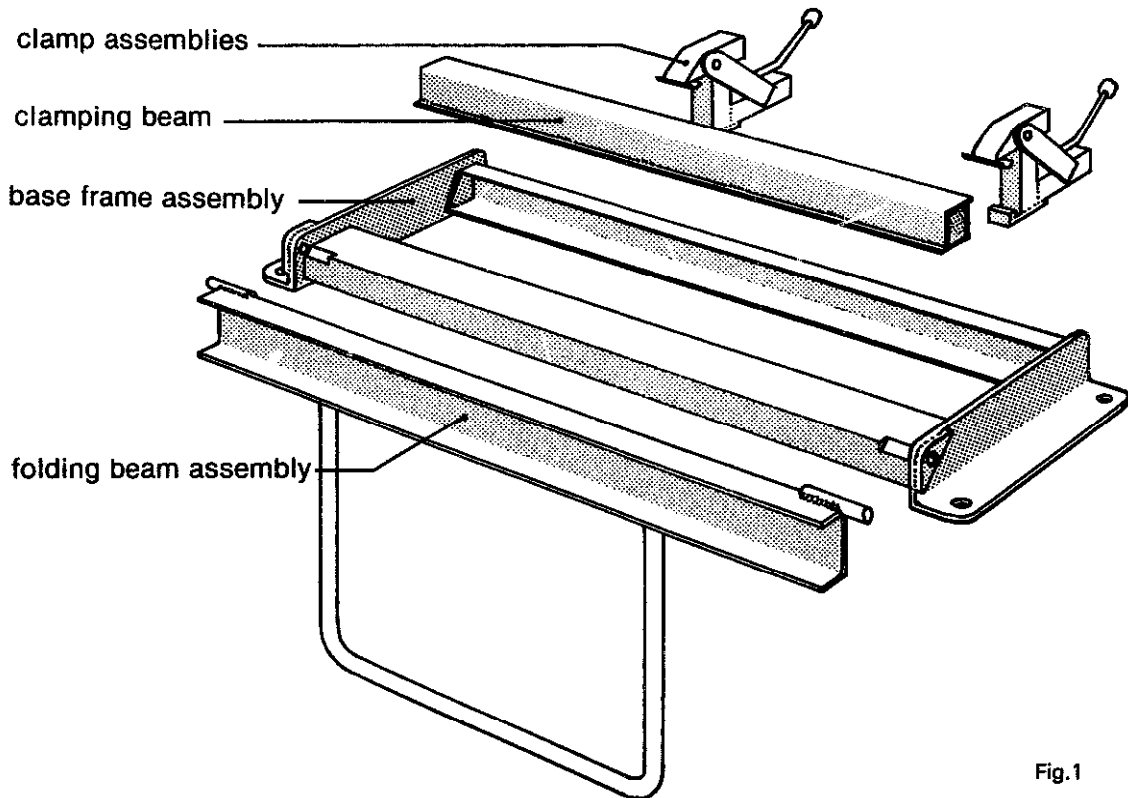

Fig.1

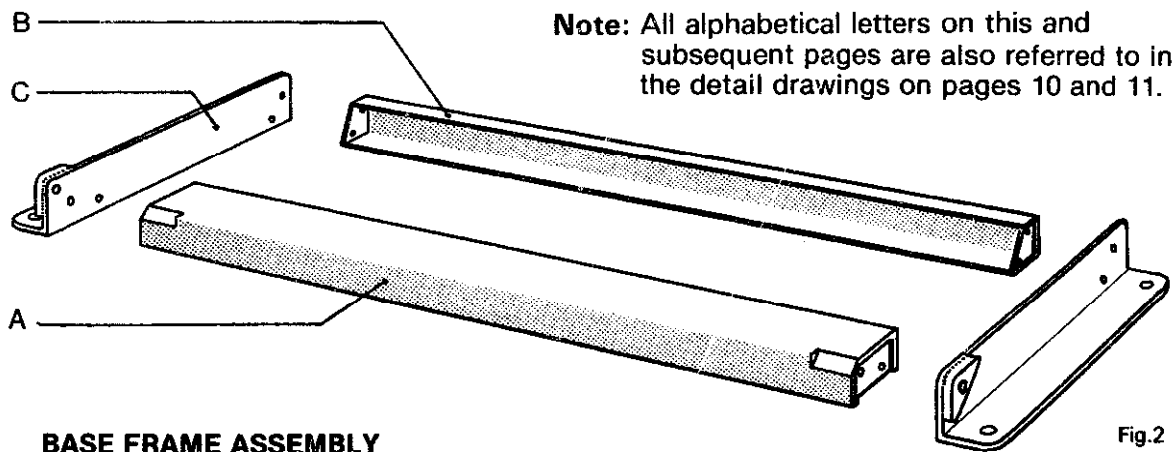

Fig.2

### BASE FRAME ASSEMBLY

This is made up of four separate fabrications: the fixed beam, the clamp slide, and two mounting plates.

- A **The fixed beam** has a plate welded in each end, and a piece of angle iron welded underneath to add rigidity. It is also notched at each end to allow for the pivot pins.
- B **The clamp slide** serves to take downward pressure as the clamps are tightened, and comprises a piece of angle, strip and two end plates.
- C **The mounting plates** are heavy angle iron which serve to fix the machine down, and hold the fixed beam and clamp slide together. They also provide the pivot location for the folding beam.

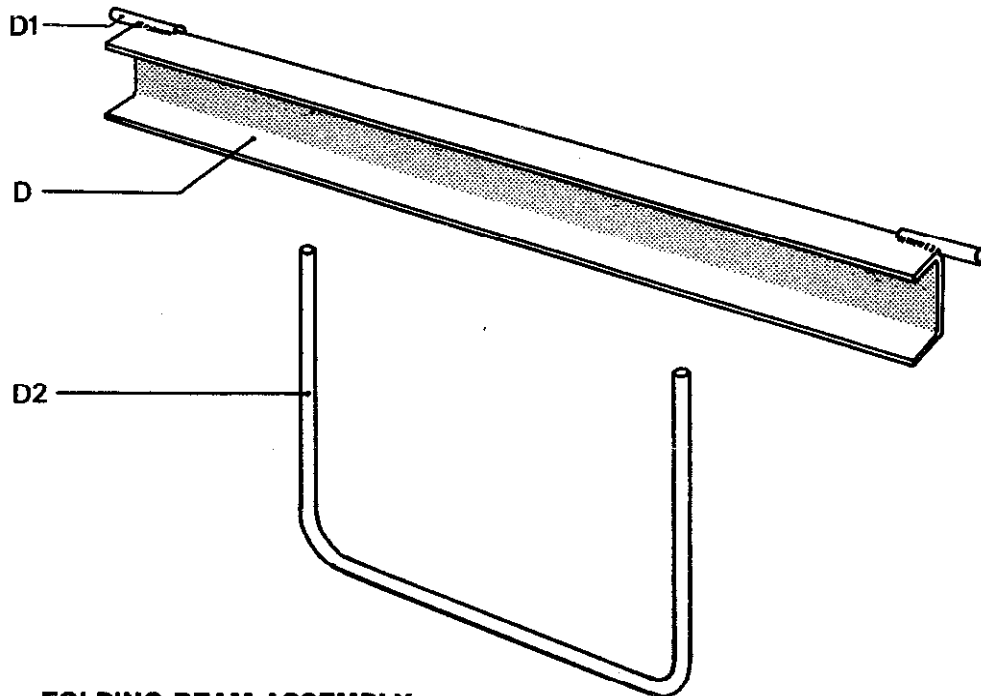

Fig.3

### FOLDING BEAM ASSEMBLY

- D **The folding beam** is a plane piece of 100 x 50mm channel. This has recesses cut at each end for the pivot pins which are welded on D1.
- D2 **The handle** is of heavy iron pipe welded to the bottom side of the channel.

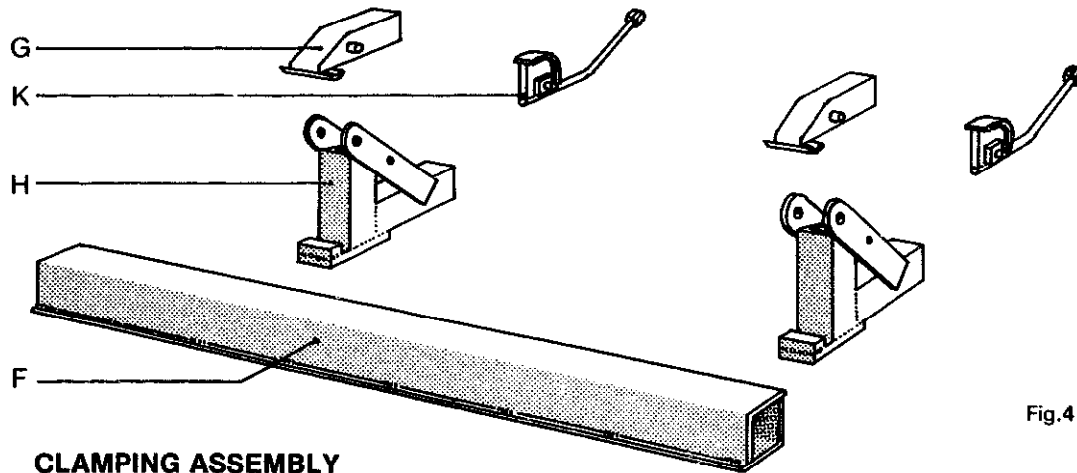

Fig.4

**CLAMPING ASSEMBLY**

The clamping beam F can be made in a number of ways, but the simplest is to weld two pieces of angle together. As will be seen from the sectional drawing below they are offset. This is to allow the steel sheet to be bent further than 90° so that it can spring back to a right angle.

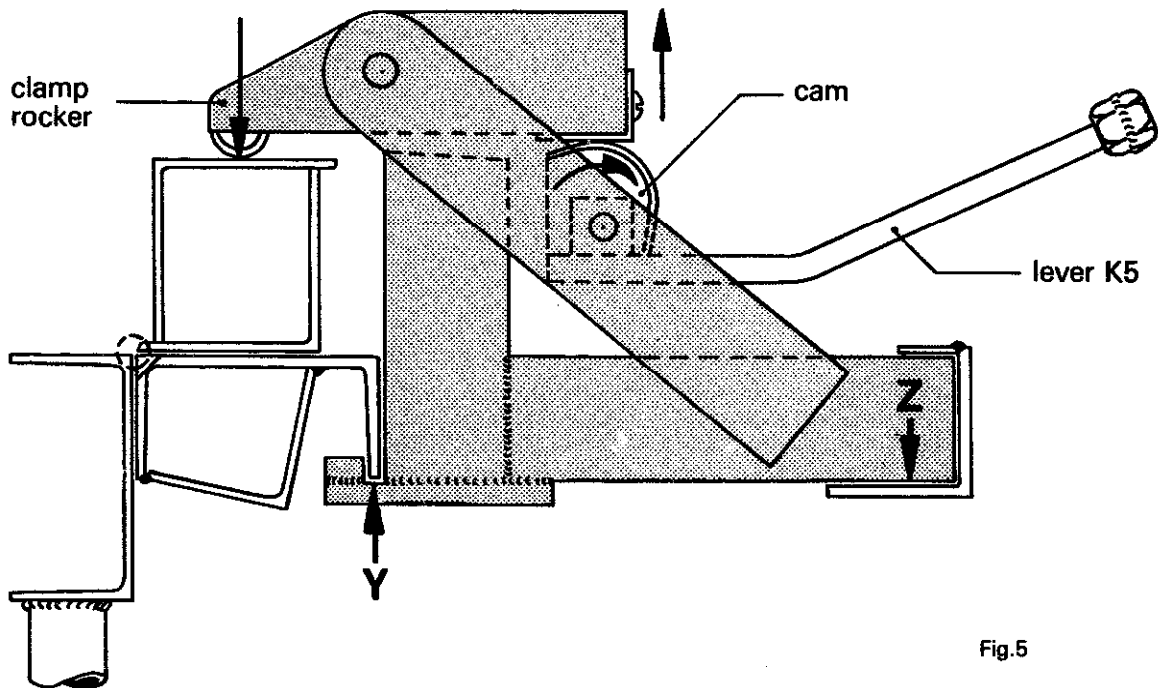
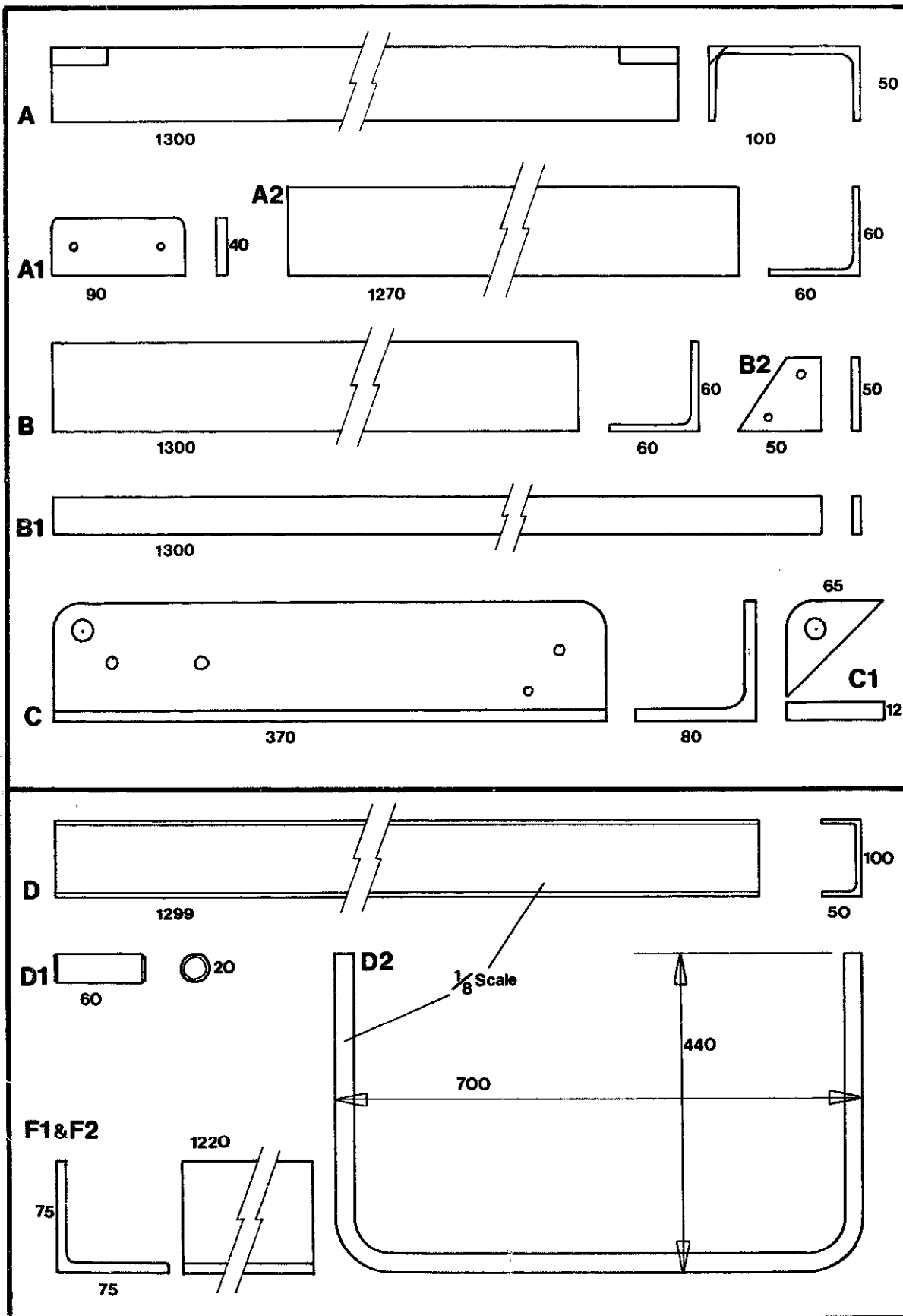
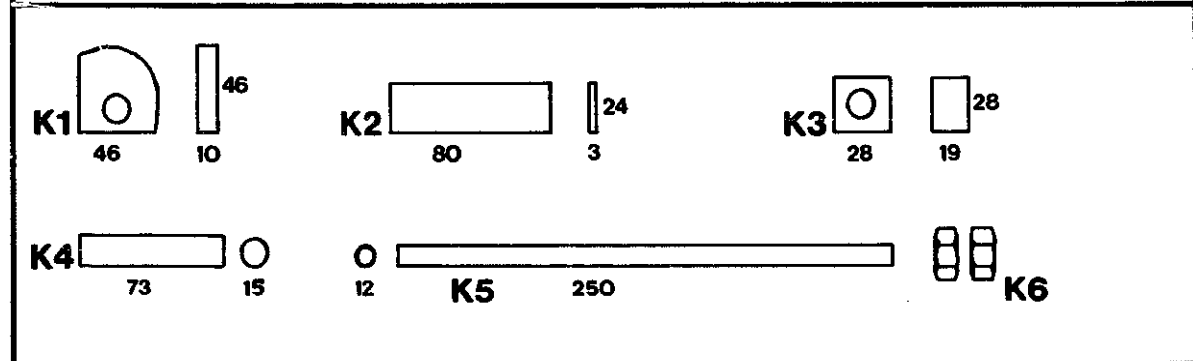
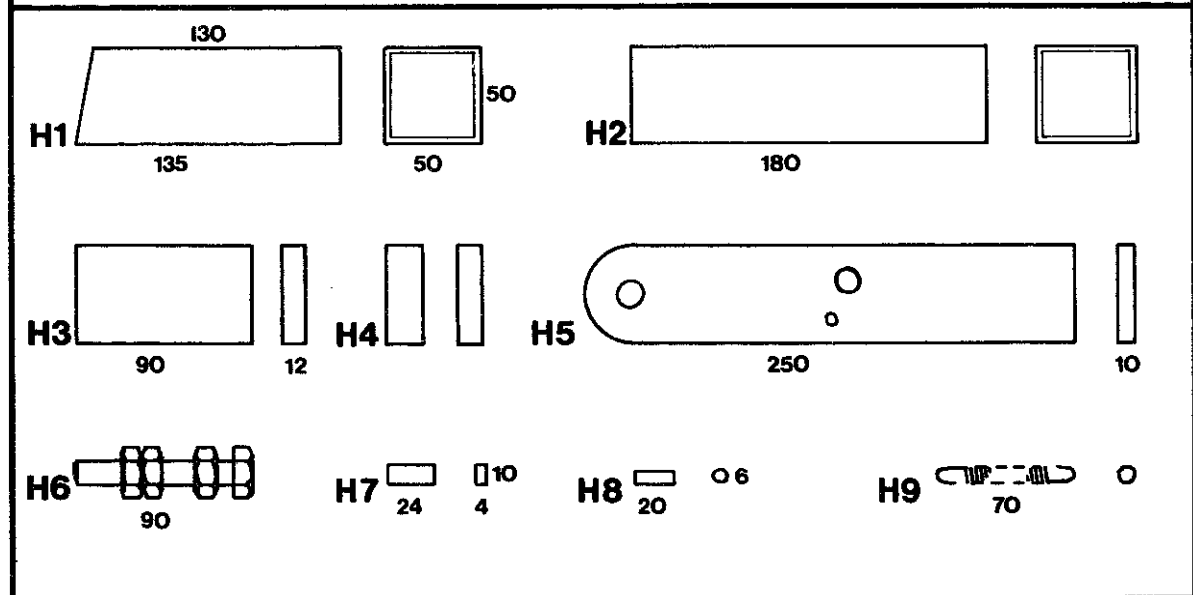
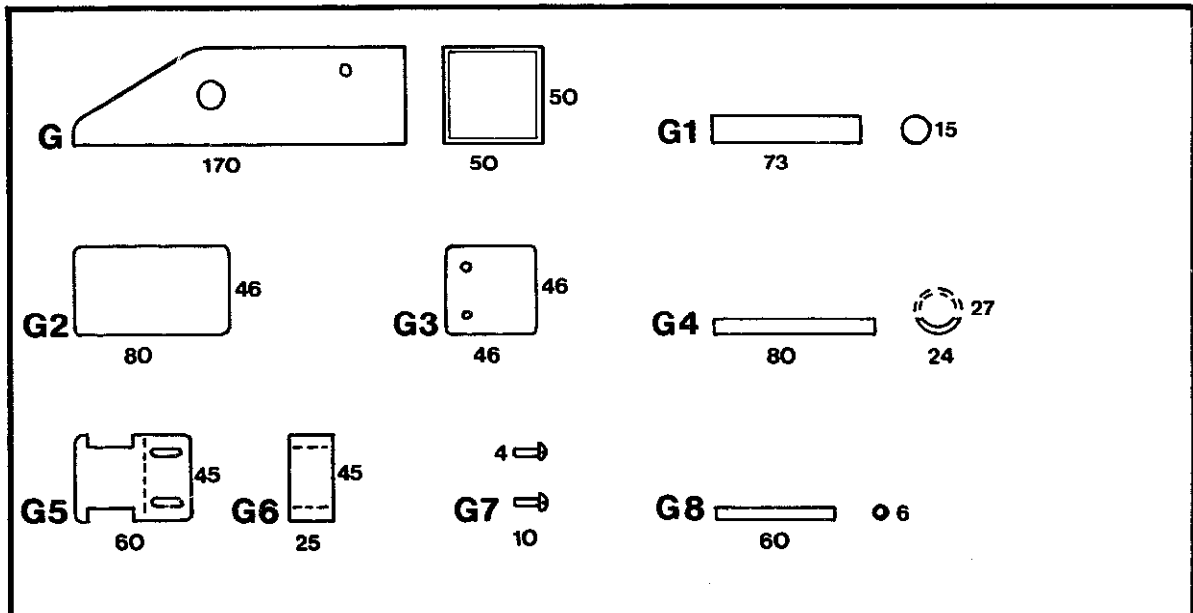

Fig.5

The clamp assemblies G, H and K are designed for quick grip and release action. They are made from 50mm box section (square hollow section, so called). They operate as follows: The lever (K5) is pushed down and turns the cam, causing the clamp rocker to apply pressure to the top of the clamping beam. The result is that point Y puts pressure upwards on the back of the fixed beam channel, and point Z puts pressure down on the clamp side. The fixed beam channel wants to turn but it is held firm by the side mounting plates.



Components D and D2 are drawn here  $\frac{1}{8}$  scale; all the other components are  $\frac{1}{4}$  scale.



**Detail Drawings of Machine Components**

Showing suggested side view and sections.

1/4 scale. Dimensions in mm.

# Construction

## BASE FRAME ASSEMBLY — PARTS

Part	Name	Quantity	Dimensions (mm)
A	Fixed beam	1	100 x 50 x 1300 M.S. channel
A1	Fixed beam end plates	2	90 x 40 x 8 M.S. flat
A2	Fixed beam reinforcing angle	1	60 x 60 x 1270 M.S. angle
B	Clamp slide	1	60 x 60 x 5 x 1300 M.S. angle
B1	Clamp slide cap	1	25 x 5 x 1300 M.S. flat
B2	Clamp slide end plates	2	50 x 50 x 5 M.S. flat
C	Mounting plates	2	80 x 80 x 370 M.S. angle
C1	Pivot blocks	2	65 x 65 x 12 M.S. flat

(M.S. = Mild Steel)

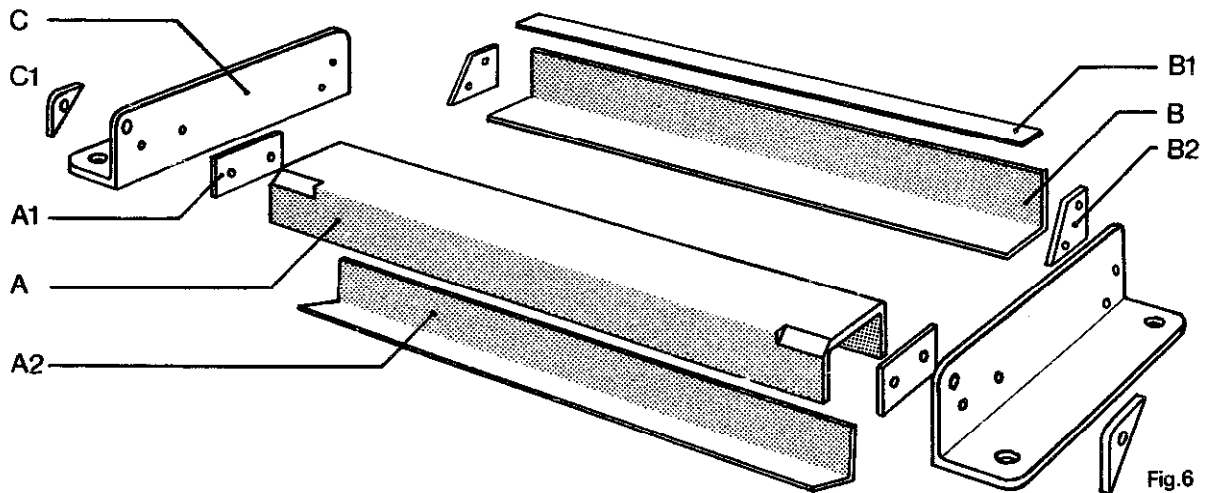
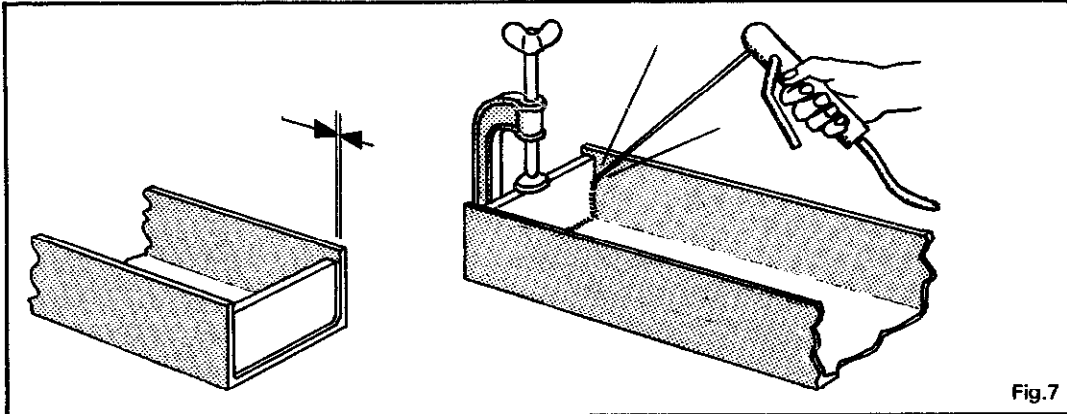

Fig.6



## BASE FRAME ASSEMBLY

Cut channel A, angle B and flat B1 to length accurately and file ends square in all planes. Cut end plates A1 and file to fit inside channel. Clamp in position just short of channel end and weld in place on inside only. Do not drill and tap yet.



Mark out and cut pivot recesses. File smooth.

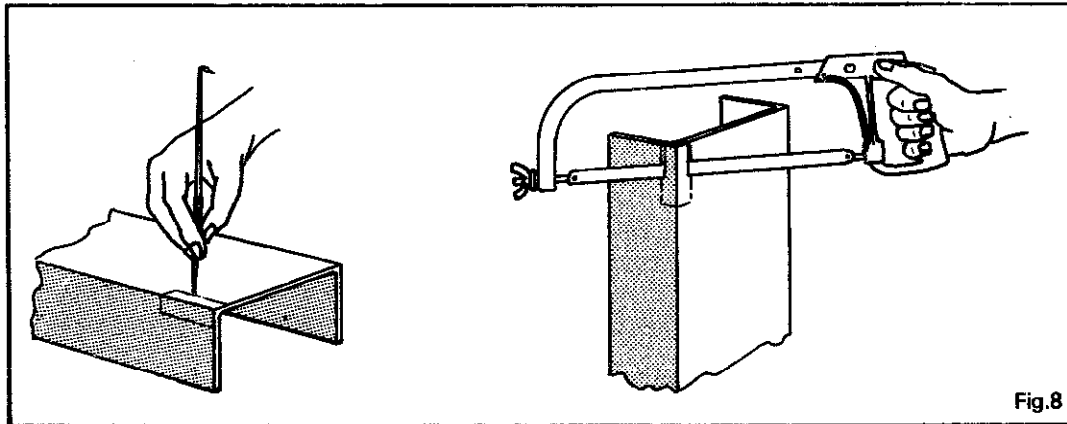

Cut angle A2 to fit in between end plates. Study cross section (Fig.9) to see how this fits. Position carefully and 'stitch weld' in place.

**'Stitch weld'** — That means put short runs of welds (approx. 25mm) at intervals of about 80mm (in this case).

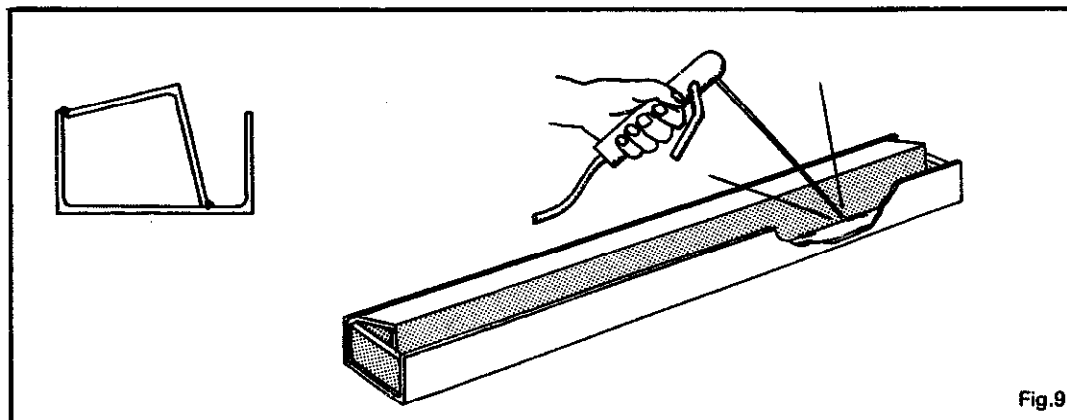

Mark out and cut clamp slide end plates (B2) and file to fit inside angle B with flat B1 resting on top. Take a piece of 50 x 50mm square hollow section (the same as will be used for the clamp base H1 and H2) to make sure that it will slide along between angle B and flat B1, pack with thin steel and clamp. Position the end plates slightly in from the end of the angle (1mm will do). Clamp, and weld on inside. Stitch weld flat B1 on to angle B. Do not drill and tap end plates yet.

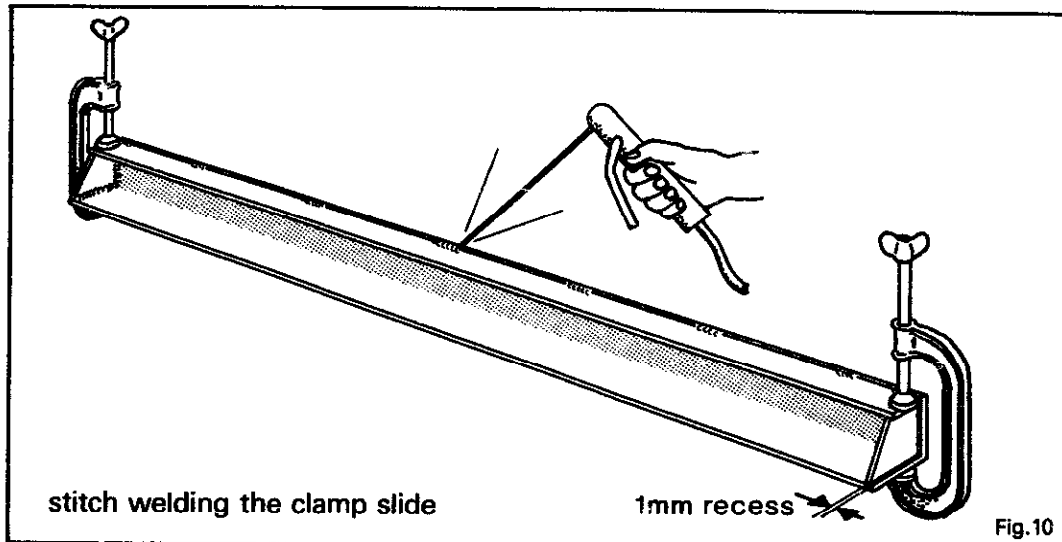

Mark out accurately and cut the mounting plates C. Centre punch and drill all holes with 3mm drill.

**Note:** Do not enlarge the holes yet.

Mark out pivot blocks C1. Drill hole 3mm, cut out and clean up edges. Clamp to mounting plates and locate hole with piece of 3mm dia. rod. Weld front and top edges only.

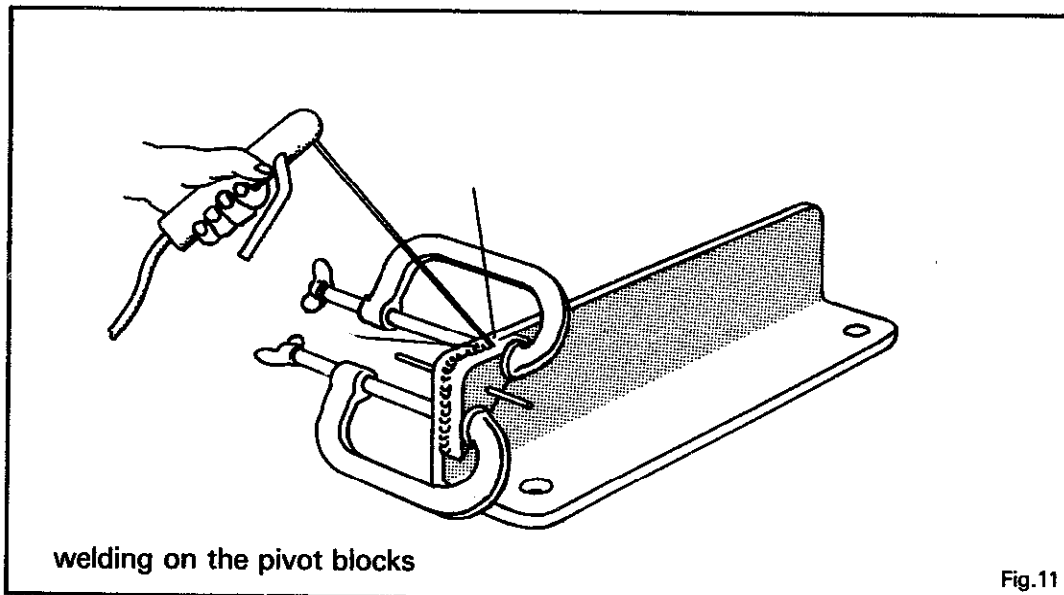

Mark out on the end plates the positions for the ends of the fixed beam, and the clamp slide.

Set up the base frame assembly using packing and clamps, and ensure that:

- all ends are in position;
- the two mounting plates are in the same plane (look along them from one end as indicated);
- the top of the fixed beam is level with the underside of the flat B1;
- **most important** - a 3mm drill inserted in the pivot hole lines up exactly with the corner of the fixed beam (Fig.12). Tap up the fixed beam gently with the hammer until this position is exact, then tighten clamps.

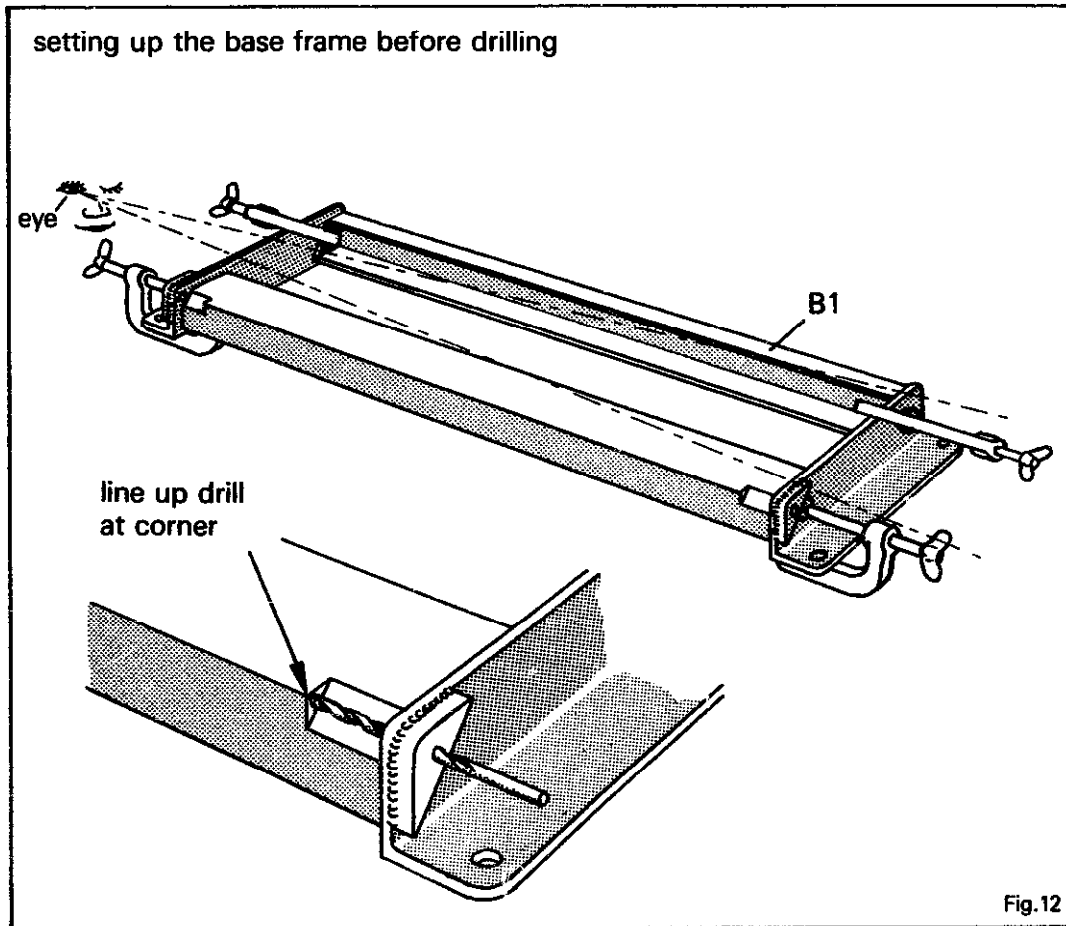

Tack weld in place if necessary in order to remove clamps for drilling. Drill holes through into end plates A1 and B2. Break tack welds with chisel and clean off. Remove all clamps. Drill and tap holes in end plates A1 and B2. Drill to size all holes in mounting plates C.

**Note:** Take care that the pivot hole is accurate and at right angles to the mounting plate. (Sharpen drill first, and use slow speed and lubricant). Check that you have a piece of round bar for the pivots the same size as you are drilling. Check now that the base frame assembly will bolt together properly. File holes out slightly only if necessary. Leave assembled.

## FOLDING BEAM ASSEMBLY — PARTS

Part	Name	Quantity	Dimensions (mm)
D	Folding beam	1	100 x 50 x 1299 M.S. channel
D1	Pivot pins	2	20 dia. x 60 M.S. rod
D2	Folding beam handle	12	25 nominal bore pipe M.S.

See diagram on page 7

dia. = diameter

### FOLDING BEAM ASSEMBLY

Cut main channel D and file ends square. Check that it fits easily between the mounting plates on the base assembly. Mark out and cut recess for pivot as indicated. It is best to cut on the short side and file the pivot pin slightly as needed.

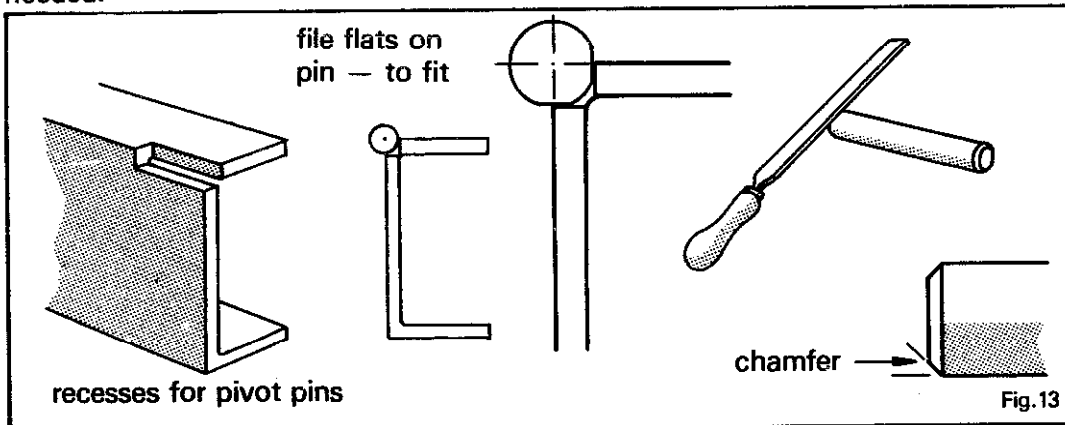

Cut the two pivot pins D and chamfer ends.

Position pins in holes in pivot blocks, and offer up the folding beam D. File pivot pins until the two tops of the beams are level, and the front faces touch when the folding beam is held in place. Clamp in position and tack pins to beam D.

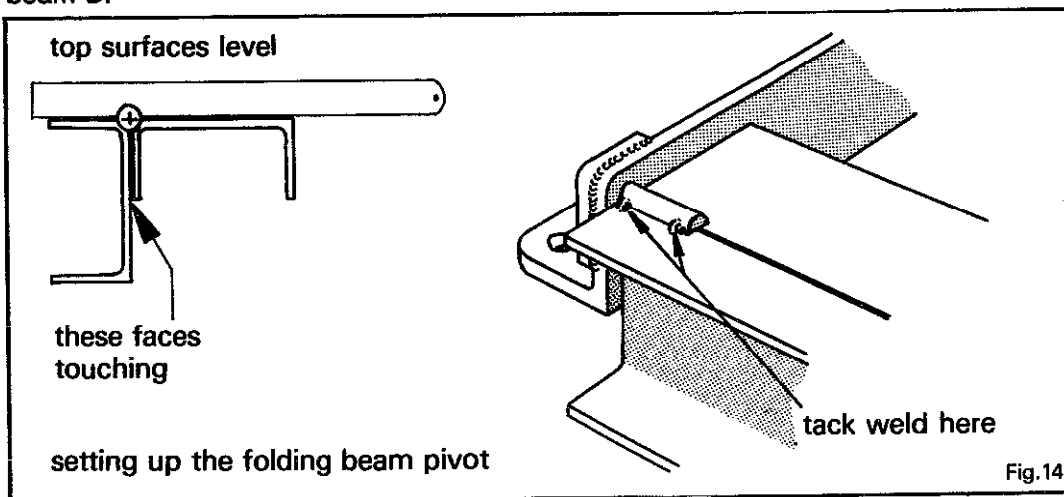

Unbolt one end mounting plate, and remove the folding beam. Complete the welds holding the pivot pins. (Make sure these are strong, especially at the outer ends of the folding beam). Refit the folding beam into the base frame and ensure that it will rotate freely, and come to rest right up against the fixed beam. Grind welds and/or fixed beam to accommodate welds as necessary.

**Handle** — If pipe-bending equipment is available the handle can be made as shown. If not, the handle can be made up either by using some pre-bent tube already available or by welding up elbow pipe fittings. Alternatively, the down tubes can be square section and the cross piece round.

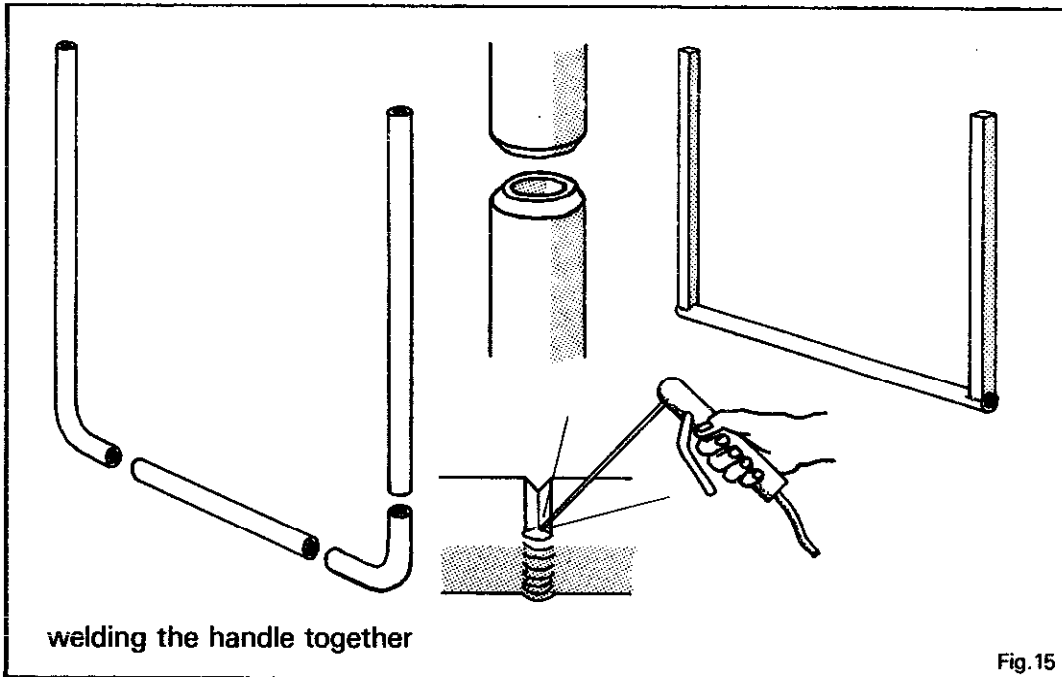

Locate the handle centrally on the folding beam, and weld in place. Build up a good strong weld as this is a point of stress.

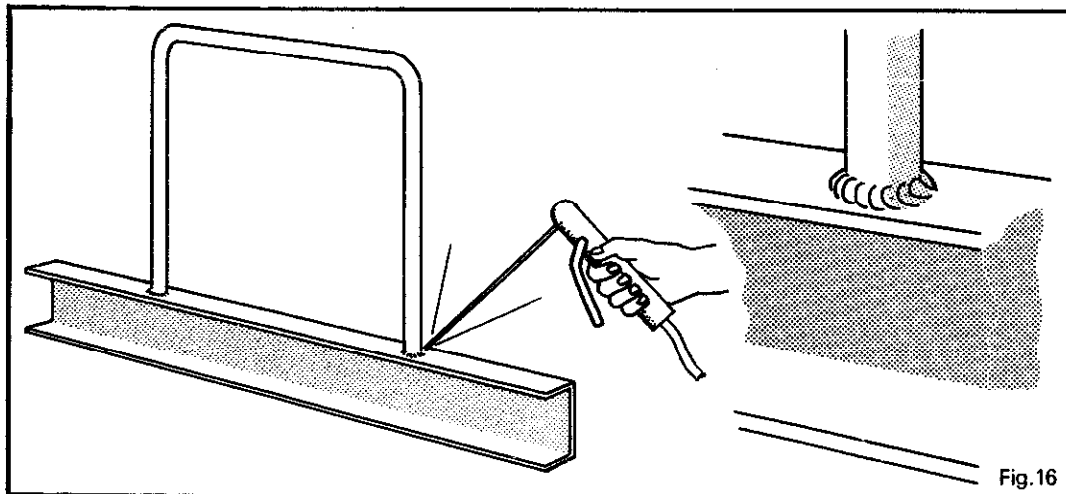

**CLAMPING ASSEMBLY —  
sub-assemblies**

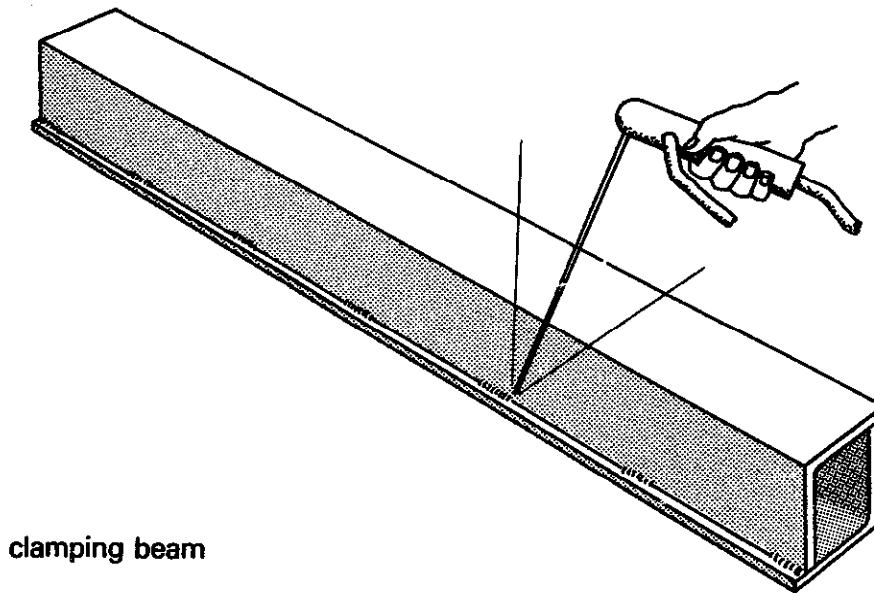
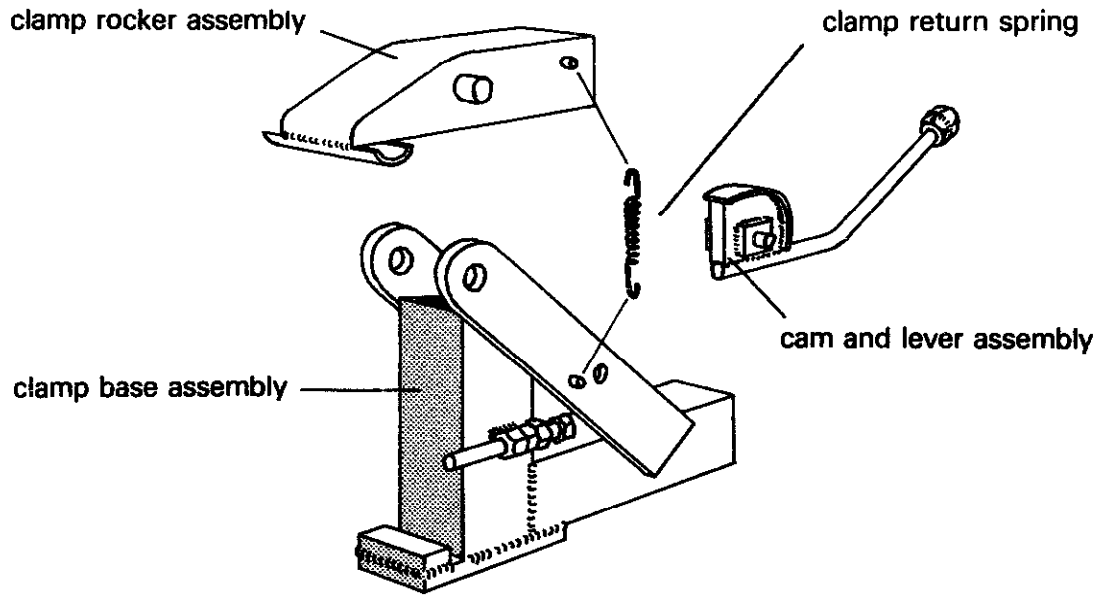

**clamping beam**

**Fig. 17**

## CLAMPING BEAM — PARTS

Part	Name	Quantity	Dimensions (mm)
F1	Clamping beam top half	1	75 x 75 x 1220 M.S. angle
F2	Clamping beam bottom half	1	75 x 75 x 1220 M.S. angle
F3	Stop screw spacers	2	as required

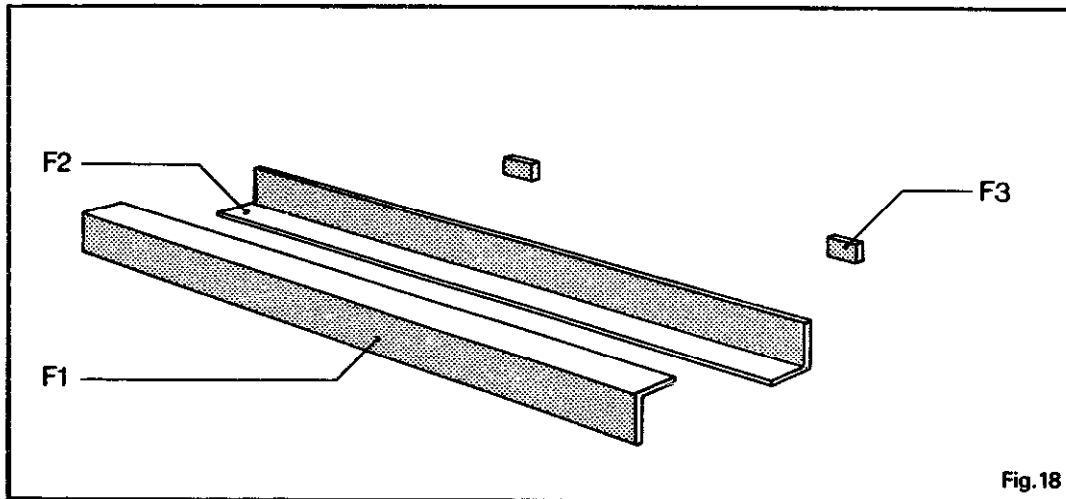

**F The clamping beam** — Cut the two pieces of angle F1 and F2. Position off set and stitch weld as indicated. Put in vice or clamp to any sensible fixed object, and grind or file the leading edge *p*. Check that it is still straight, and correct as required.

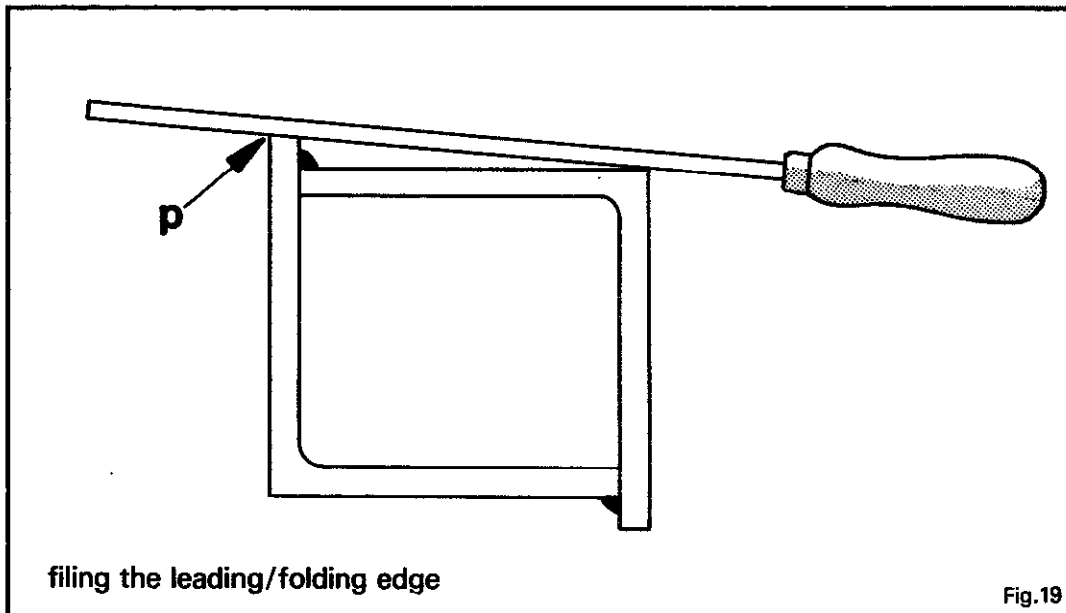

## CLAMP ROCKER ASSEMBLY — PARTS

Part	Name	Quantity	Dimensions (mm)
G	Rocker body	2	50 x 50 x 170 M.S. box
G1	Rocker pivot	2	15 dia. x 73 M.S. Rod
G2	Rocker top cap	2	80 x 45 x 2 M.S. plate
G3	Rocker end cap	2	46 x 46 x 4 M.S. plate
G4	Clamp foot	2	piece of 27 O.dia. pipe x 80
G5	Cam follower	2	see drawing on page 11
G6	Shim	2	see drawing on page 11
G7	Screws	4	4 dia. U.N.C. x 10
G8	Return spring pin	2	6 dia. x 60 approx M.S. rod

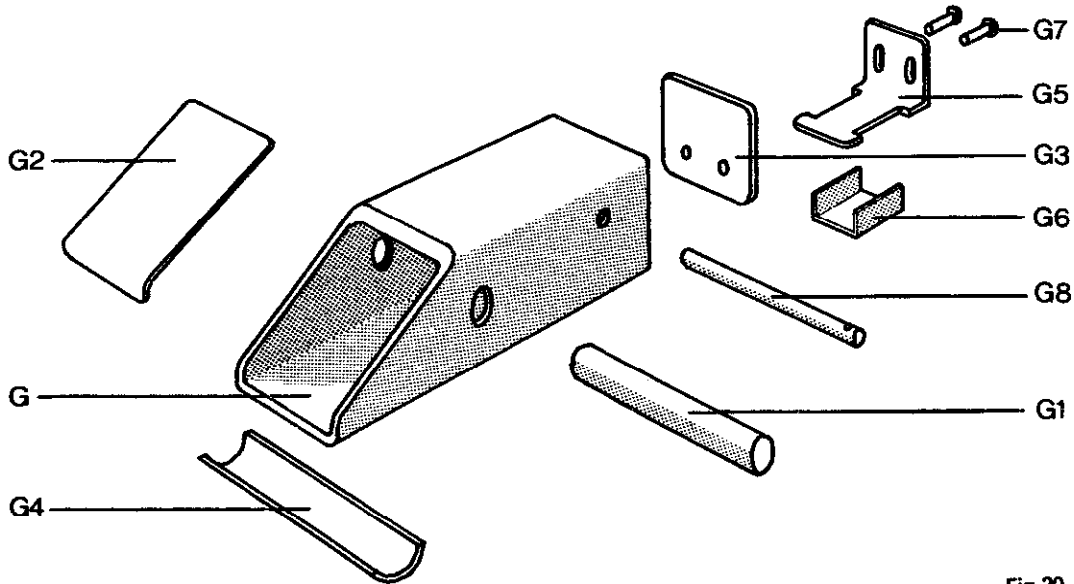

Fig.20

### CLAMP ROCKER ASSEMBLIES

Remember to make two of each part whilst marking out and cutting. The following describes the fabrication of one rocker.

Cut the 50 x 50mm square hollow section as shown and drill the holes for the pivot G1. Cut the pivot G1 and position through the rocker, with equal amounts protruding each side. Weld it in place from inside at the front. Cut, bend and file a piece of 2mm plate to fit the front opening and weld in.

Cut a piece of water pipe and file to size shown. Position centrally at tip of rocker and weld front and back.



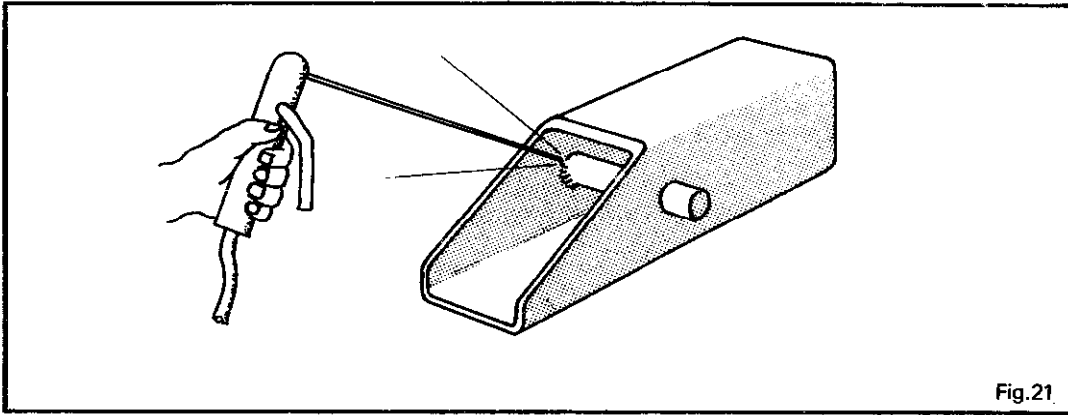

Fig.21

Cut and file a piece of 3 - 4mm plate to fit the back opening, and drill and tap as shown. Fit and weld.(Put screws G7 in whilst welding to avoid getting weld in the threads).

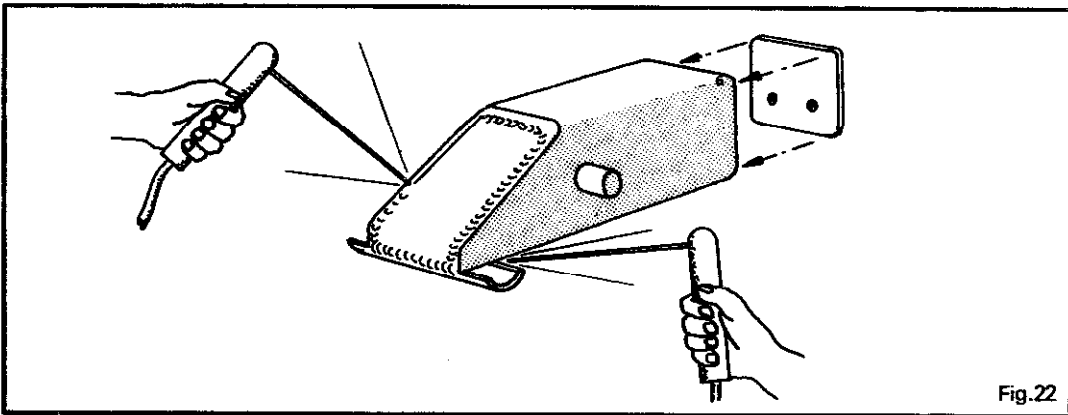

Fig.22

Make up cam follower from 1.5mm steel sheet, and drill and file elongated holes. Cut piece of brass sheet G6 and wrap around G5.

**Note:** This brass shim can be packed out with more brass or steel shim to increase the clamping pressure. It is also easily replaced if wear occurs.

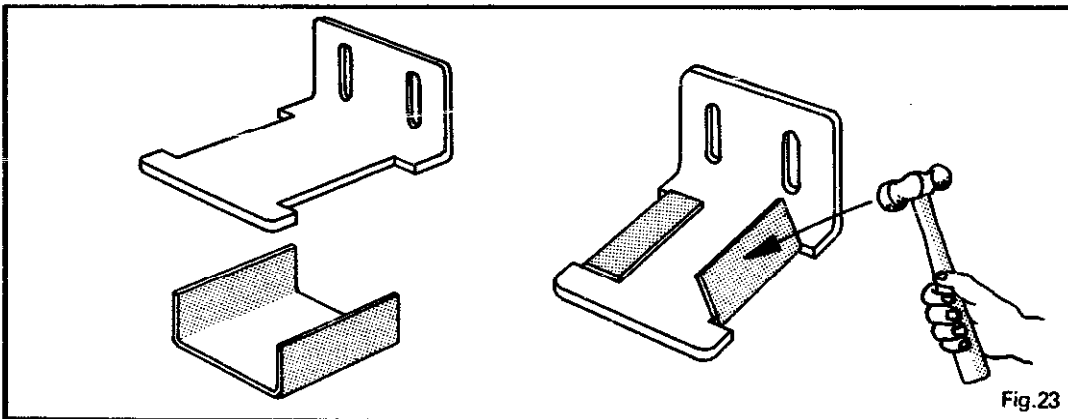

Fig.23

## CLAMP BASE ASSEMBLY — PARTS

Part	Name	Quantity	Dimensions (mm)
H1	Clamp base column	2	50 x 50 x 135 M.S. box
H2	Clamp base foot	2	50 x 50 x 180 M.S. box
H3	Clamp base tongue	2	50 x 12 x 90 M.S. flat
H4	Clamp base lip	2	50 x 12 x 18 M.S. flat
H5	Rocker pivot supports	4	50 x 10 x 250 M.S. flat
H6	Clamping beam stop screw	2	12 dia. U.N.C. x 90
H7	Stop screw spacer	2	10 x 5 x 25 M.S. flat
H8	Clamp base return spring pin	2	6 dia. x 20 M.S. rod
H9	Rocker return spring	2	10 dia. x 70 approx

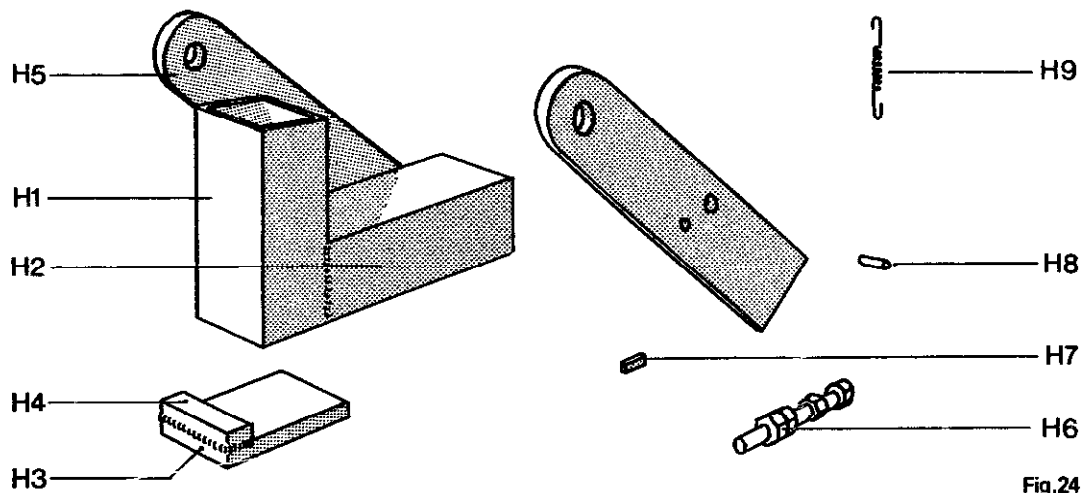

Fig.24

## CLAMP BASE ASSEMBLY

Cut pieces H1 and H2. Ensure front edge of H2 is a right angle. Clamp and weld. (A wood worker's sash clamp is particularly useful for this).

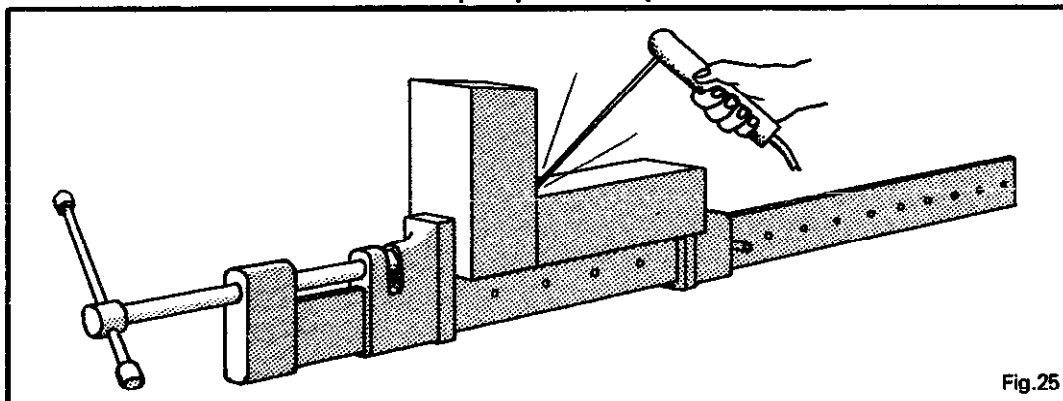

Fig.25

Cut H3 and H4. Clamp together and weld front and side edges. Clamp H3 to H2. Set the distance of the lip H4 from the column H1 by hooking on to the back edge of the channel A. Shown here upside down.

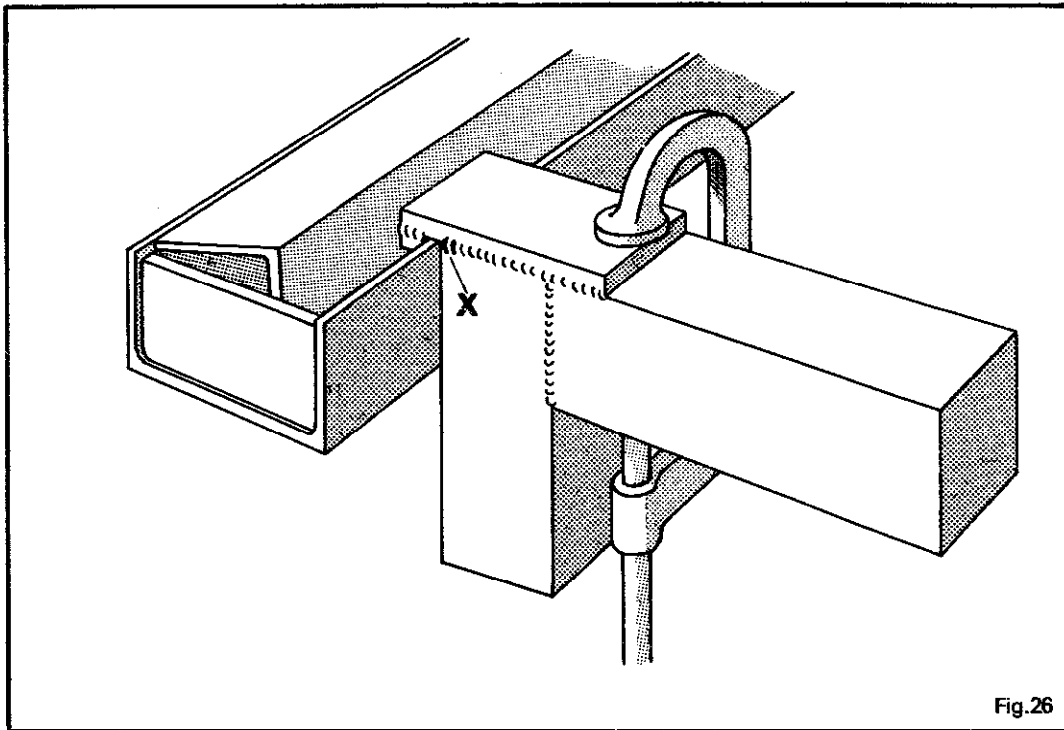

Fig.26

Check that the clamped assembly will slide freely from side to side. Remove assembly from the channel and weld foot on to base both sides, making sure of an extra strong weld at X. Mark out accurately, cut and drill pivot supports H5. Clamp one side to the base and position accurately as indicated. Weld in place. **DO NOT WELD OTHER PIVOT SUPPORT ON YET.**

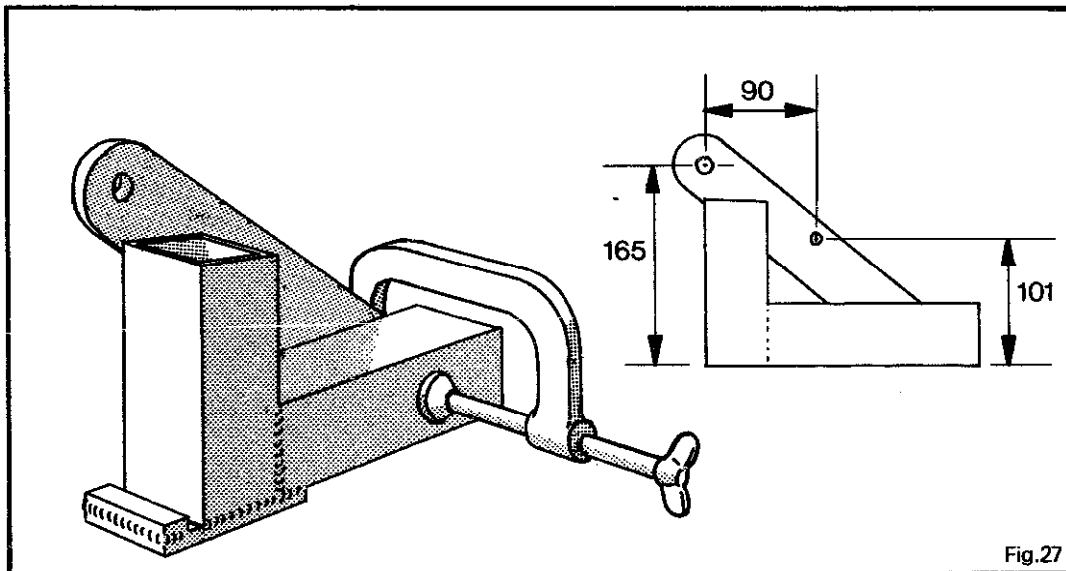
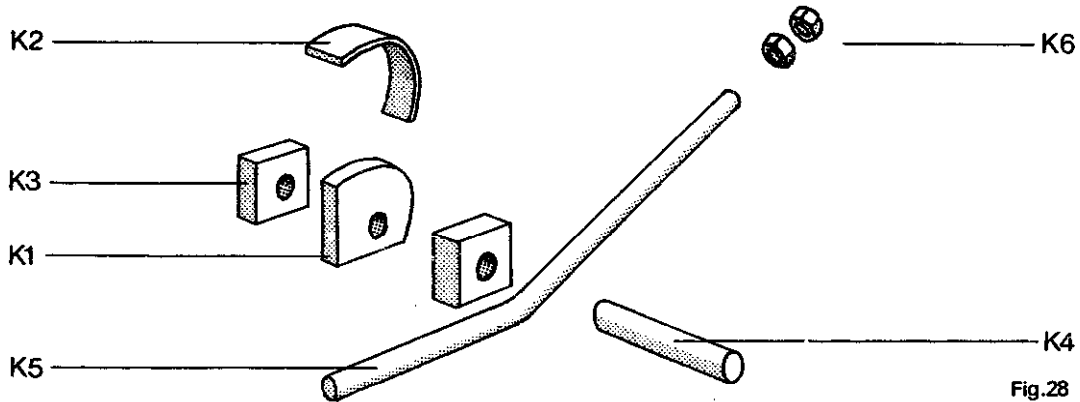

Fig.27

**CAM & LEVER ASSEMBLY — PARTS**

Part	Name	Quantity	Dimensions (mm)
K1	Cam	2	10 x 45 x 45 M.S. plate
K2	Cam shell	2	25 x 3 x 80 M.S. flat
K3	Cam spacers	4	28 x 28 x 19 M.S. bar
K4	Cam spindle	2	15 dia. x 73 M.S. rod
K5	Cam lever	2	12 dia. x 250 M.S. rod
K6	Cam handle	4	12 threaded nut



**CAM ASSEMBLY**

Cut out pattern for cam profile. Position pattern on a square corner of a piece of 10mm plate and stick down with tape or clamp on. Centre punch the centre of the cam pivot, and then along the profile of the cam at intervals as shown. Remove pattern and drill hole 3mm and then to size. Cut profile over size and grind almost to line of dots. Finish with a file and check for squareness all round.

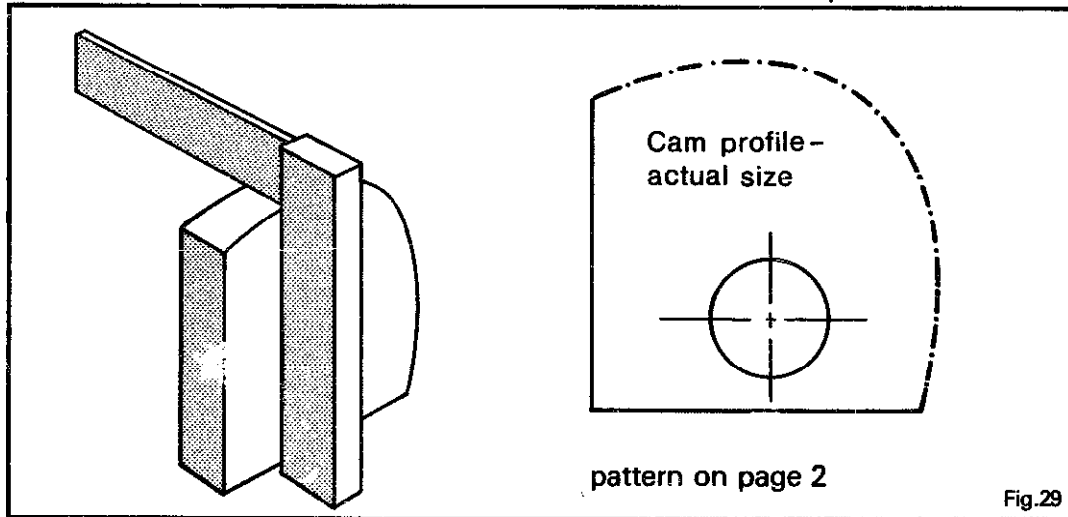

Cut strip for cam shell K2. Position as shown overlapping each side of the cam equally and parallel with the cam when viewed from the end. Tack weld each side.

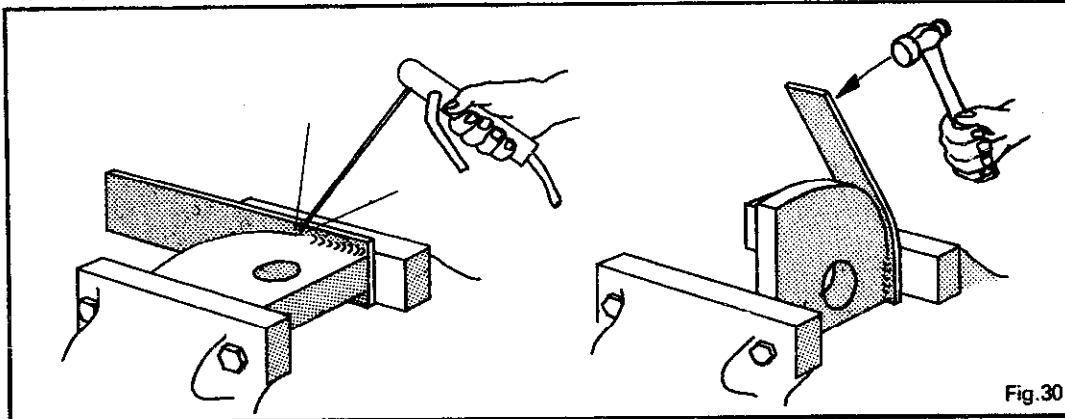

Heat cam shell with a blow torch till red hot, or put in a forge so that only the shell gets red. Clamp in vice and hammer shell round to fit the cam. Clamp tightly round and weld (Fig.30).

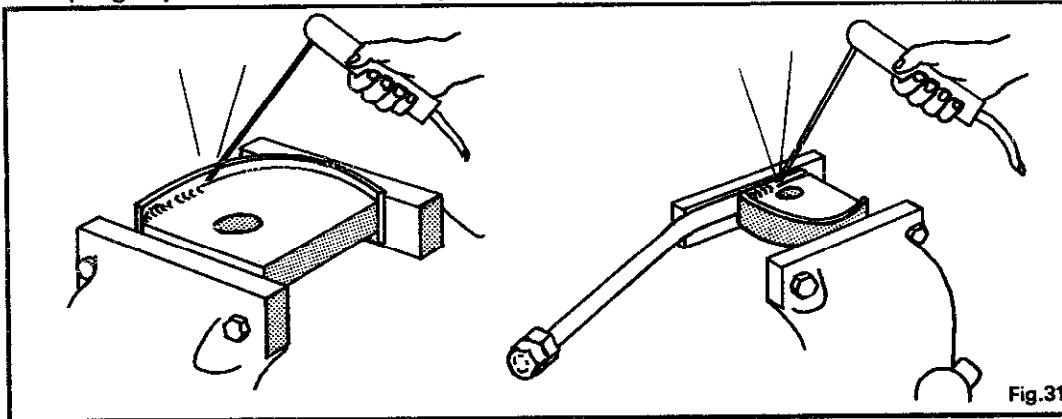

Cut length of rod for lever K5 and find four nuts K6. Bend the lever as shown, and weld the nuts on to the long end. Grind off corners of nuts to make a smooth knob. Clamp the lever on to the cam and weld both sides. Mark out spacers K3 on a bar and drill to size. Then cut off. Cut spindles K4. Assemble spacers and cam on spindles centrally. Weld spacers on to cam.

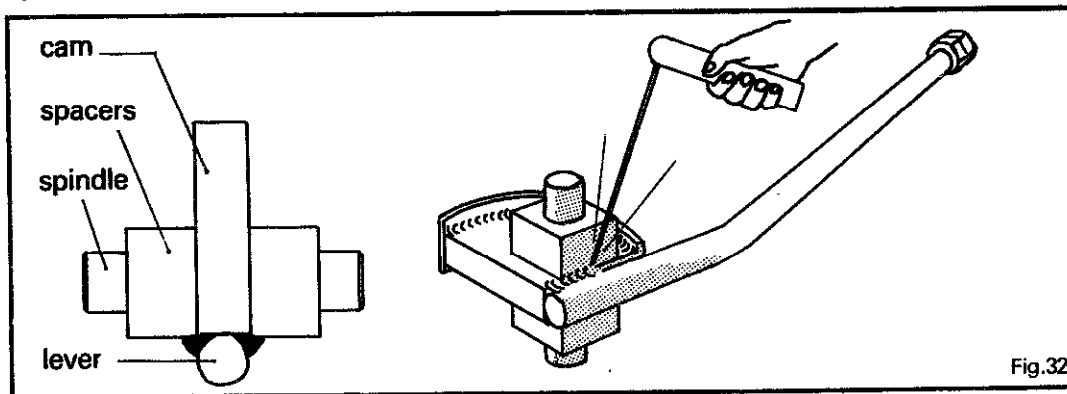

**AT** MICROFICHE  
REFERENCE  
LIBRARY

A project of Volunteers in Asia

How to Make a Folding Machine for Sheet Metal Work

by: Rob Hitchings

Published by:

Intermediate Technology Publications, Ltd.  
9 King Street  
London WC2E 8HN  
United Kingdom

Paper copies are \$ 3.75.

Available from:

Intermediate Technology Publications, Ltd.  
9 King Street  
London WC2E 8HN  
United Kingdom

Reproduced by permission of Intermediate  
Technology Publications, Ltd.

Reproduction of this microfiche document in any  
form is subject to the same restrictions as those  
of the original document.

# How to make a folding machine for sheet metal work

Rob Hitchings

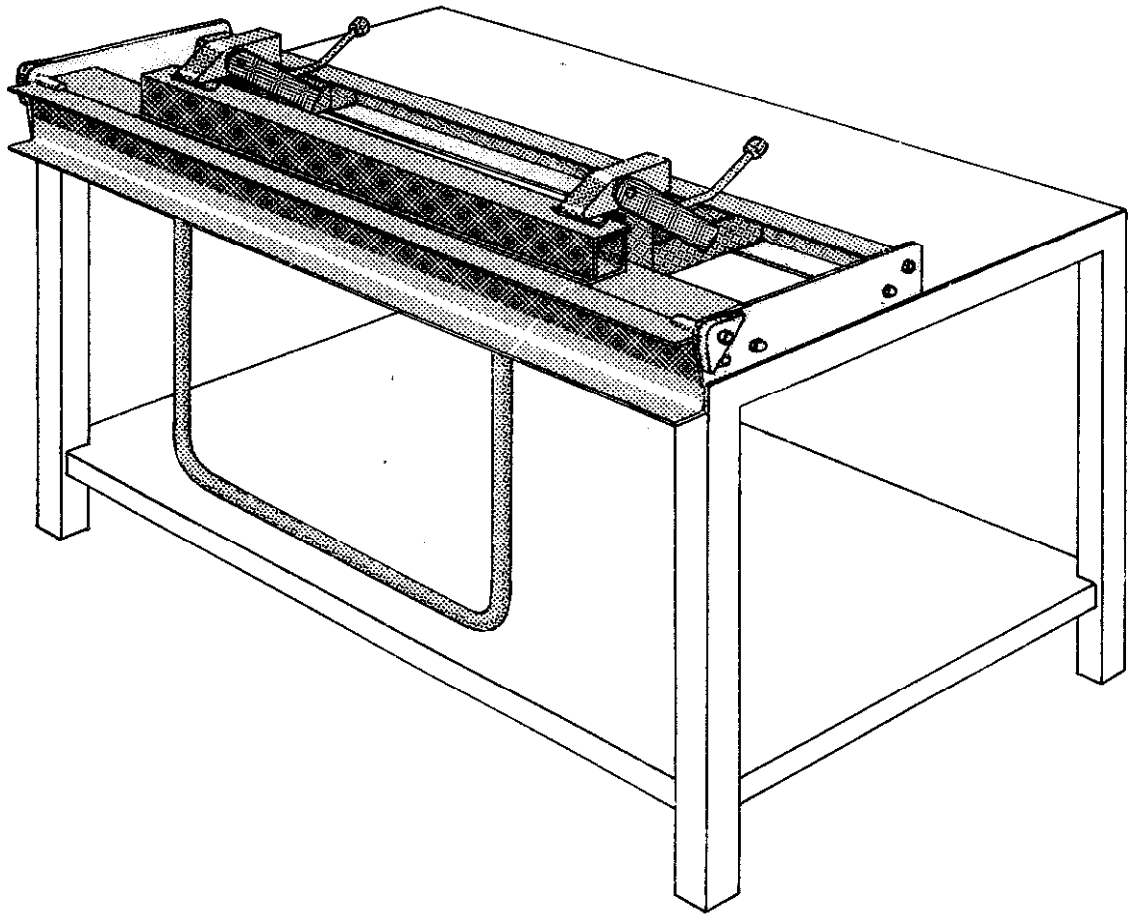

**This manual, *How to make a folding machine for sheet metal work*, gives full details on how to build and use a versatile machine for working sheet metal.**

Such a machine offers the increased facility of being able to readily produce items in sheet metal such as ducting, steel boxes, trays and agricultural equipment. It is equally useful for vehicle building and repair work.

Designed specifically for construction from readily available steel sections, the machine could be built by most small metal workshops and blacksmiths.

The ability to make locally, equipment for small farms and villages in rural areas, is being increasingly seen as very useful, both in the developing countries and in the more industrialized nations.

With the rising cost of fuel for transportation and growing awareness of the finite resources of the planet, it makes sense to encourage local self reliance and small-scale production of certain equipment.

The clear illustrations and step-by-step building instructions make this a very practical manual for any small workshop wishing to increase its capacity to fabricate in sheet metal.

**The Author** (who also illustrated and laid out the pages for this manual), has a background in 'practical' engineering and appropriate technology workshops. His business (ApT Design & Development), based in Cumbria (N.W. England), design and make village scale equipment for workshops both in the developing and industrialized countries.

Rob Hitchings is interested to hear from other designers/engineers who are building similar equipment around the world and hopes that a network of people may emerge who can share ideas and collaborate together to develop further designs.

Intermediate Technology Publications Ltd., 9 King St., London WC2E 8HN, England.

ISBN 0 903031 76 0



# **HOW TO MAKE A FOLDING MACHINE FOR SHEET METAL WORK**

**Designed and written by Rob Hitchings**

Step-by-step instructions on how to build a versatile machine for folding sheet metal to produce box sections e.g. ducting, and pans/trays etc. Includes detailed plans, operating instructions, and several design options.

**Intermediate Technology Publications Ltd.**

## Acknowledgements

Financial assistance in the final development of this machine as well as in the production of this booklet was made available through Intermediate Technology Industrial Services from a grant from the Overseas Development Administration. Their assistance is gratefully acknowledged.

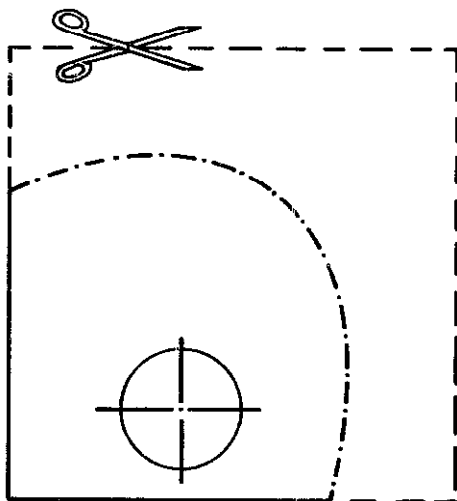

### Pattern for cam

refer to page 24

Cut out square.  
Tape on to metal.  
Centre punch through  
pattern on dots and  
pivot centre.

© Intermediate Technology Publications Ltd. 1981.  
9 King Street,  
London WC2E 8HN

ISBN 0 903031 76 0  
Printed by the Russell Press Ltd, Nottingham. U.K.

## **Introduction**

The sheet metal folding machine, the construction of which is described in detail in this booklet, is cheap to build and versatile in use. It can be made from readily-available channel, angle and hollow steel sections using basic welding and fabrication techniques. The only equipment essential to its construction is a drilling machine, an electric welder, G clamps and basic hand tools. An angle grinder, mechanical hacksaw and a flame cutter would make it easier, though these tools are not essential.

Construction can be modified to suit locally-available materials. The machine can be bolted on to a strong bench or mounted on a stand.

Once constructed, this machine will be found very useful in any small metal workshop to make objects in sheet metal such as boxes, trays, baking-pans, channels, air-ducts, chimney flues, funnels, cabinets; or agricultural equipment such as seed-hoppers, troughs, water and fuel tanks.

This folding machine should prove an invaluable tool in any small workshop in the industrialized countries, as well as in the Third World.

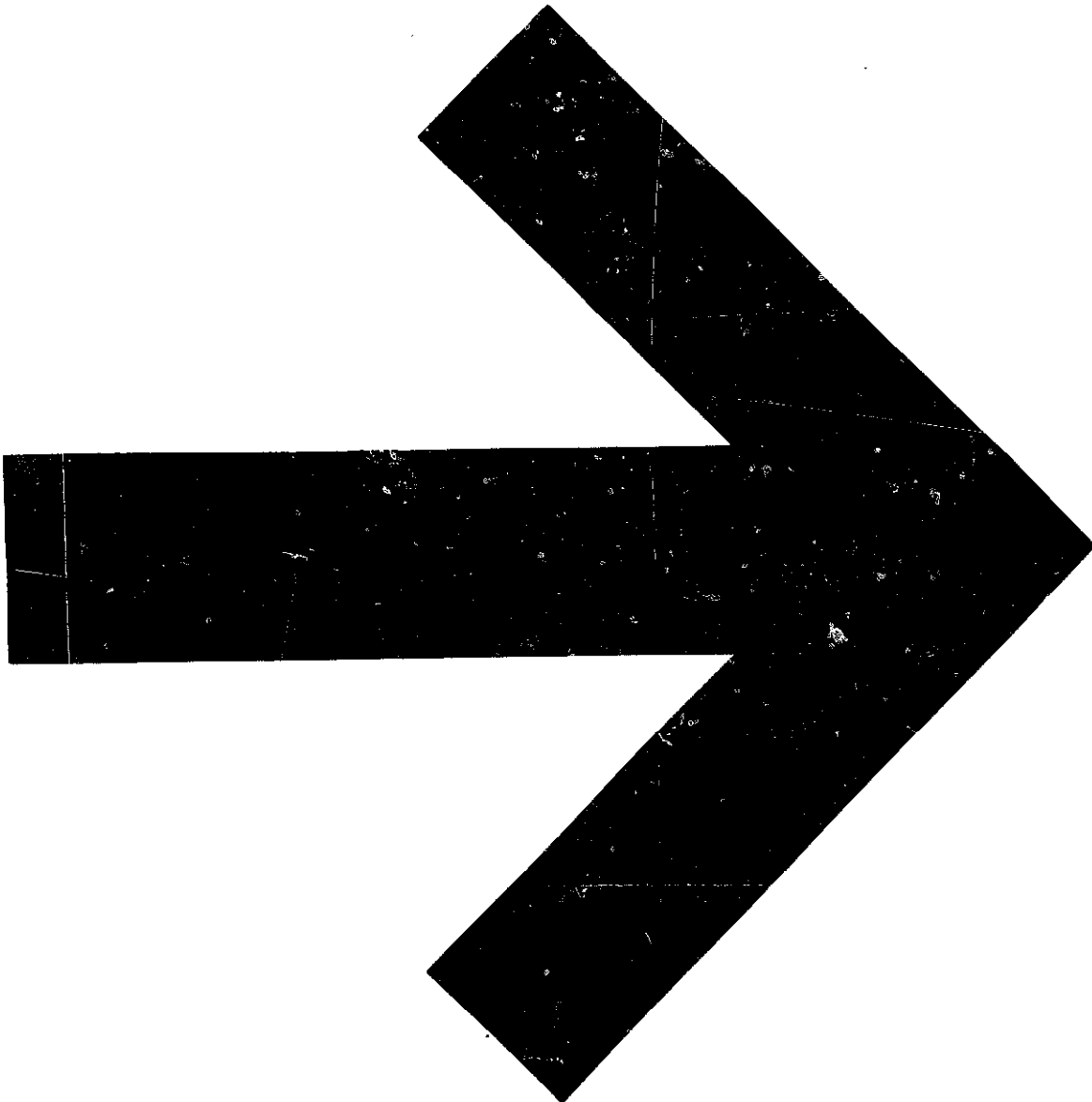

# Contents

	Page
Introduction	3
Uses of the machine	6
Description	7
Detail drawings of machine components	10
Construction	12
Operation	27
Optional designs	29

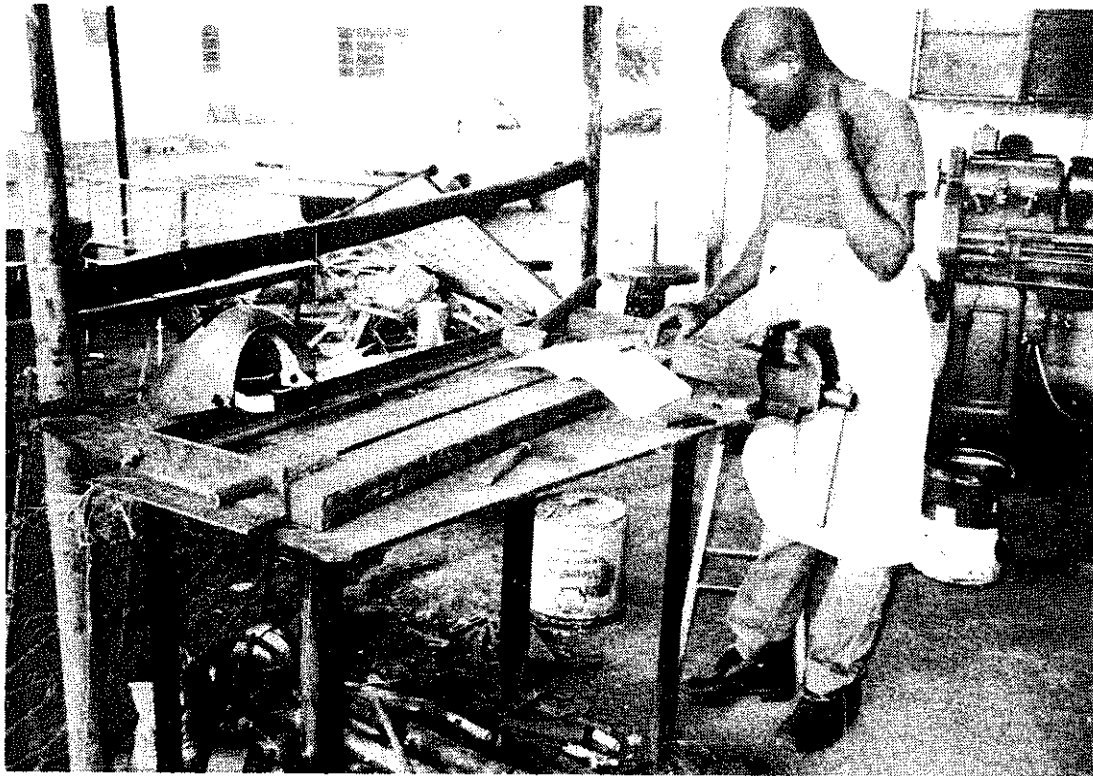

*Manufacturing and testing the machine in Botswana.*

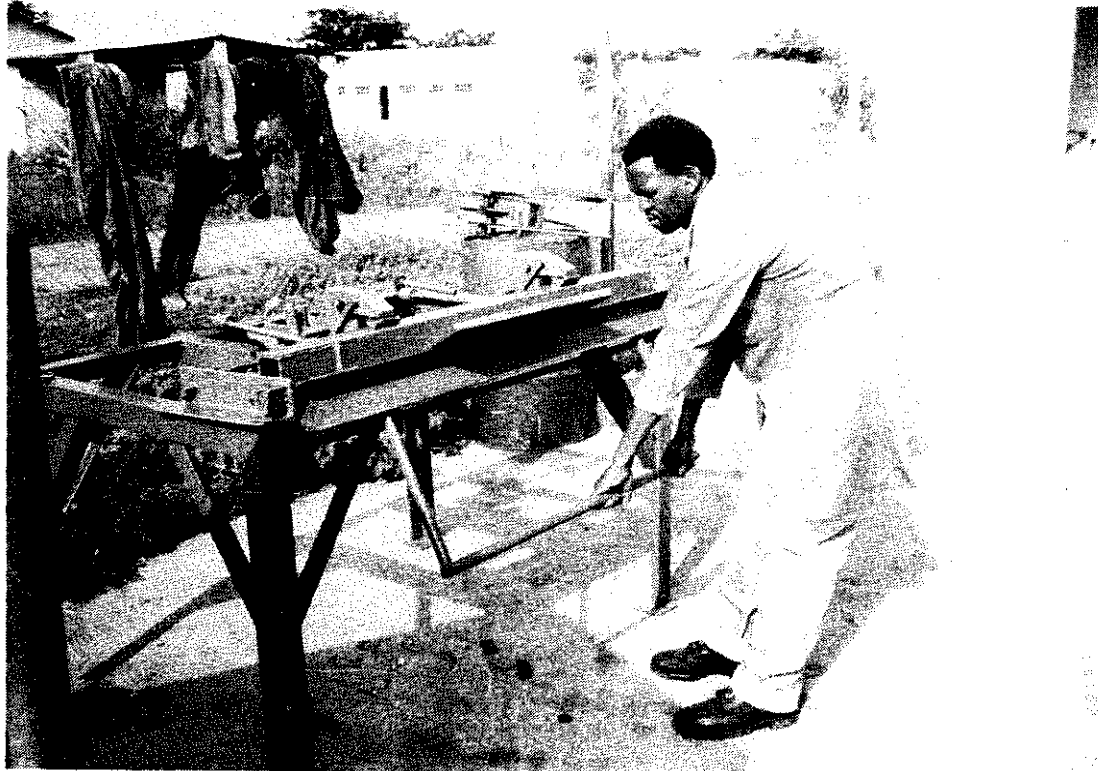

## Uses of the folding machine

The machine will bend steel sheet up to 16 guage (approx. 1.5mm thick) x 1 metre wide and can produce both box sections, and pans up to 100mm deep (150mm on modified machine).

Once the basic machine has been built it can be adapted in numerous ways to do almost any sheet metal folding job (within the capacity of the machine's strength). Several adaptations are suggested in the optional design section.

Some of the shapes and suggested items which this folding machine can produce are illustrated below.

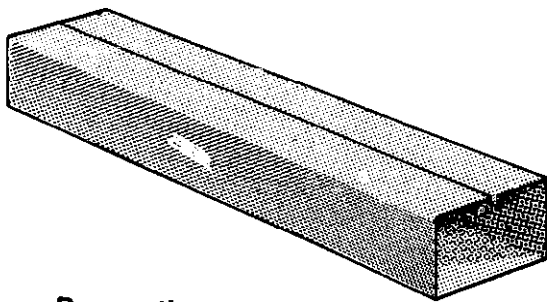

**Box sections:**  
air ducts, chimneys, structural work.

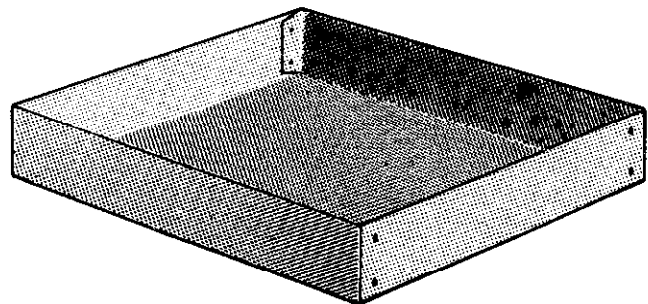

**Pans:**  
boxes, trays, lids, troughs, water/fuel tanks.

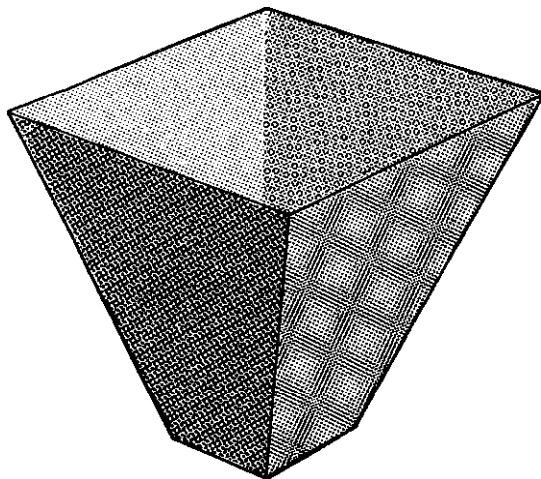

**Funnels:**  
Grain/seed hoppers etc.

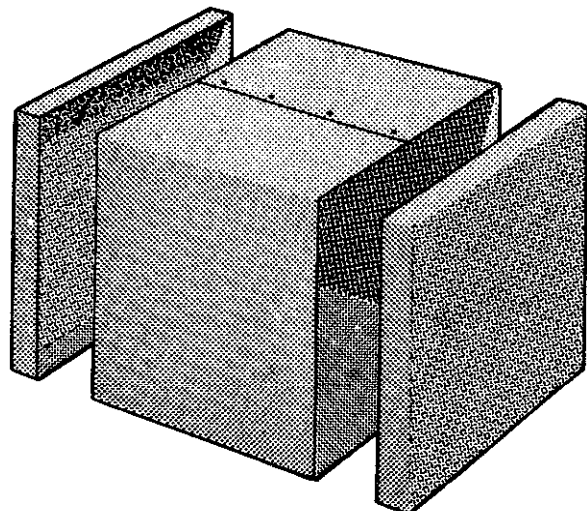

**Large boxes/tanks**

## Description

The machine comprises:

- The base frame assembly, which is suitably fixed down.
- Two clamp assemblies, which act on .....
- ..... the clamping beam, which clamps the sheet metal along the line that requires folding.
- The folding beam which is pivoted at each end. This has a handle which is raised and thus causes the clamped sheet metal to bend. The clamps slide from side to side to adjust to whatever width needed. Several clamping beams can be made to suit the widths of four-sided trays/pans required. This is not necessary for box sections (ducting), or for normal straight folds. In such cases the full width beam can be used.

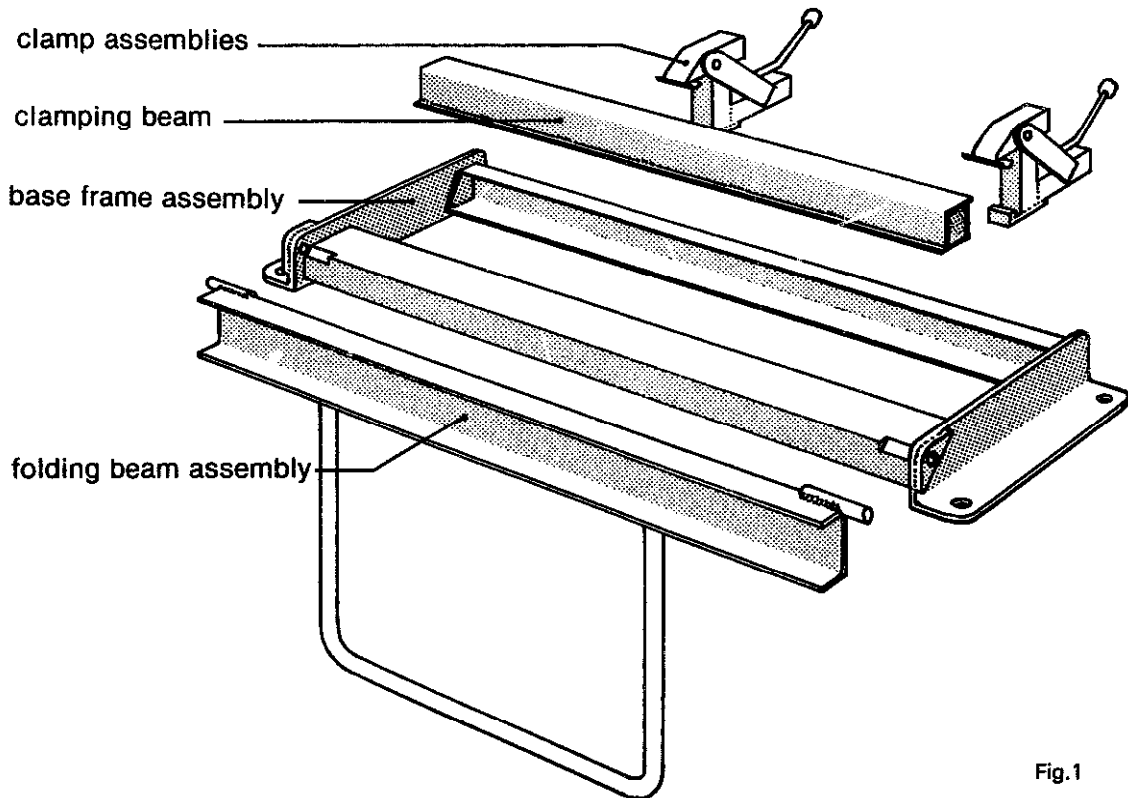

Fig.1



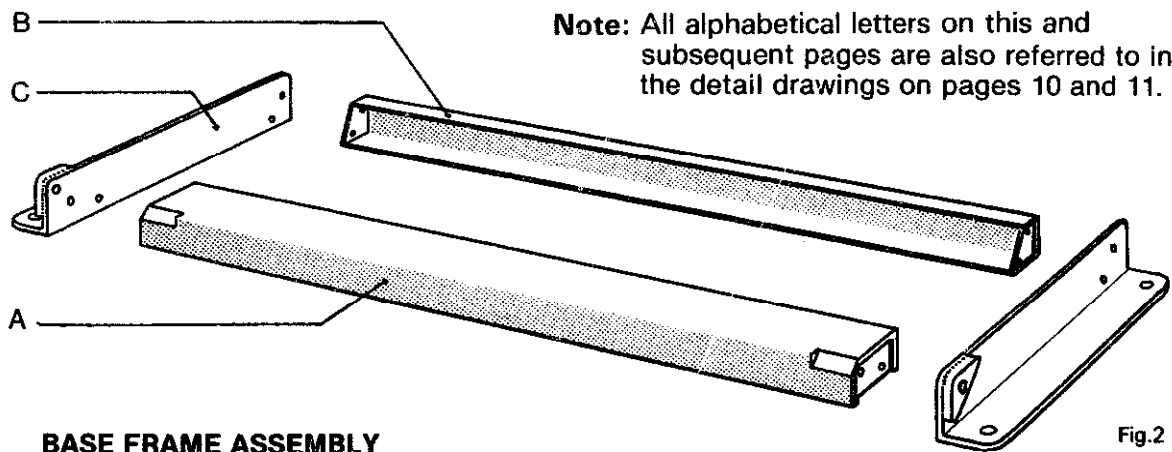

Fig.2

### BASE FRAME ASSEMBLY

This is made up of four separate fabrications: the fixed beam, the clamp slide, and two mounting plates.

- A **The fixed beam** has a plate welded in each end, and a piece of angle iron welded underneath to add rigidity. It is also notched at each end to allow for the pivot pins.
- B **The clamp slide** serves to take downward pressure as the clamps are tightened, and comprises a piece of angle, strip and two end plates.
- C **The mounting plates** are heavy angle iron which serve to fix the machine down, and hold the fixed beam and clamp slide together. They also provide the pivot location for the folding beam.

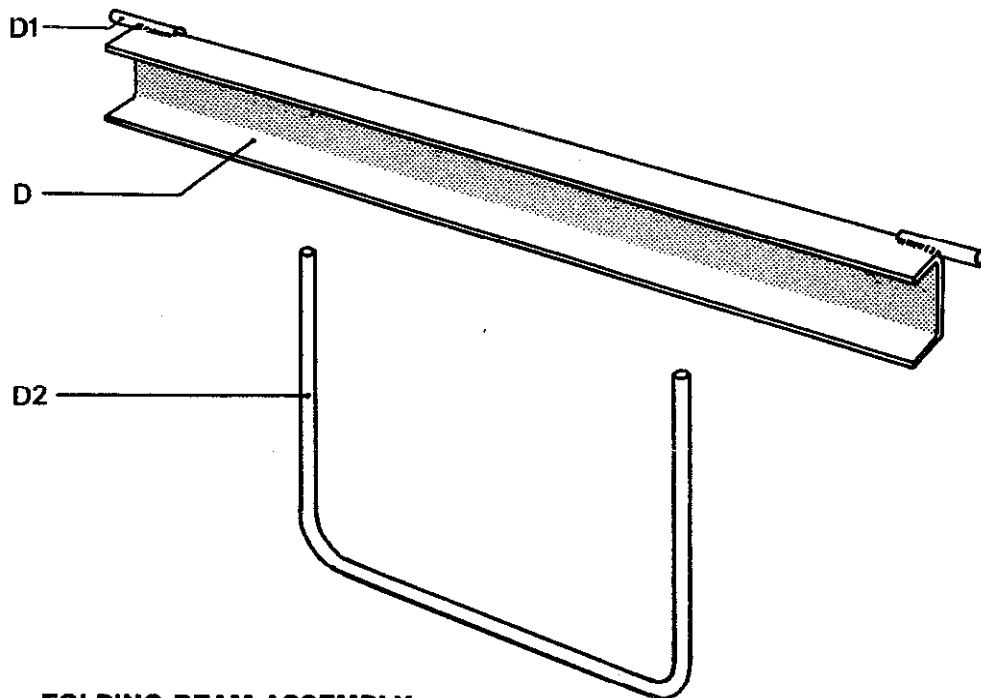

Fig.3

### FOLDING BEAM ASSEMBLY

- D **The folding beam** is a plane piece of 100 x 50mm channel. This has recesses cut at each end for the pivot pins which are welded on D1.
- D2 **The handle** is of heavy iron pipe welded to the bottom side of the channel.

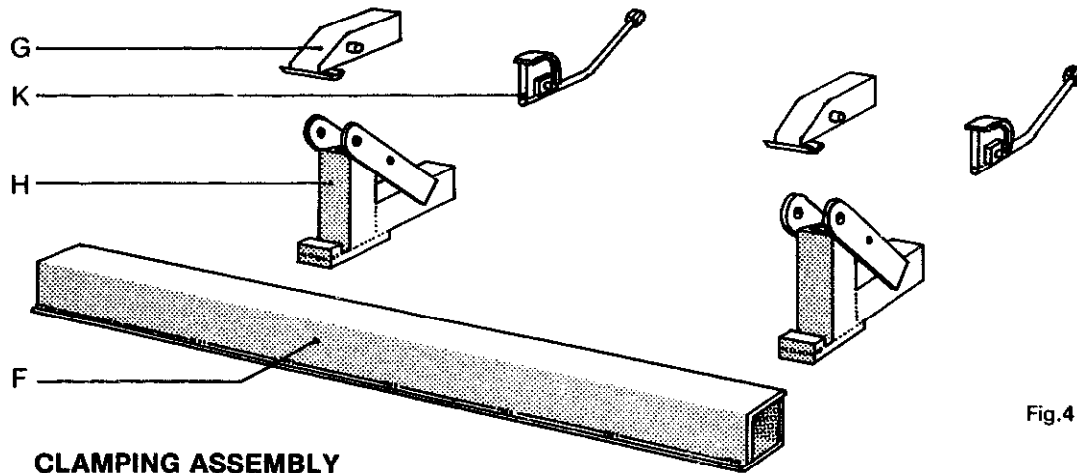

Fig.4

**CLAMPING ASSEMBLY**

The clamping beam F can be made in a number of ways, but the simplest is to weld two pieces of angle together. As will be seen from the sectional drawing below they are offset. This is to allow the steel sheet to be bent further than 90° so that it can spring back to a right angle.

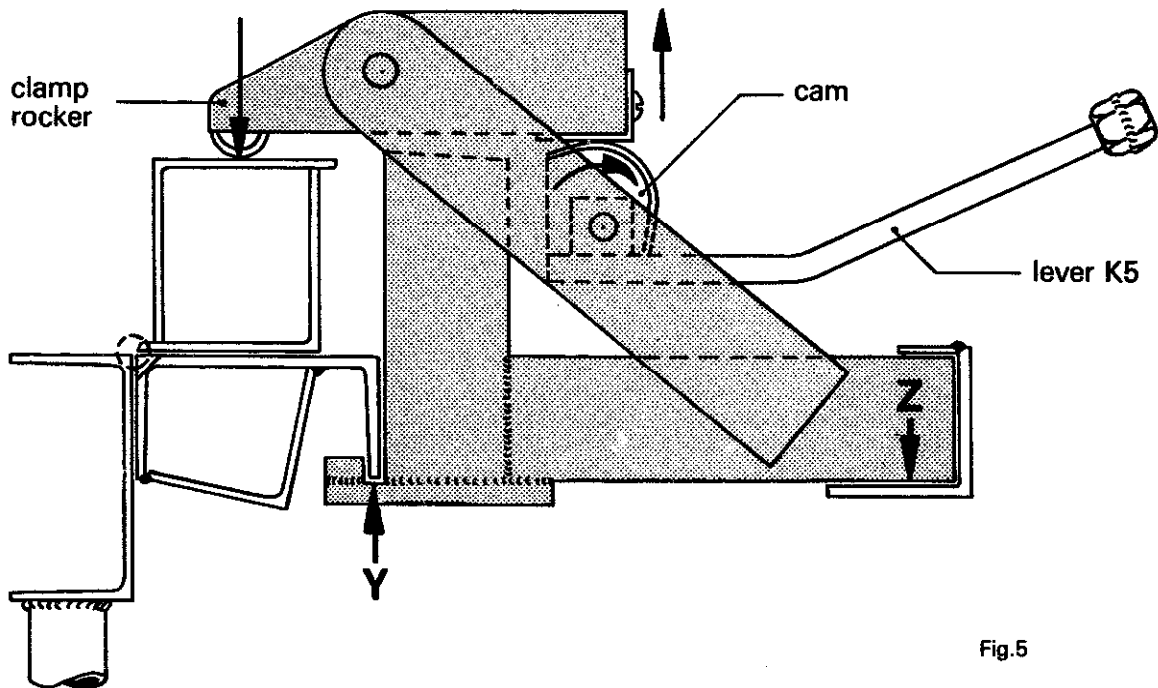
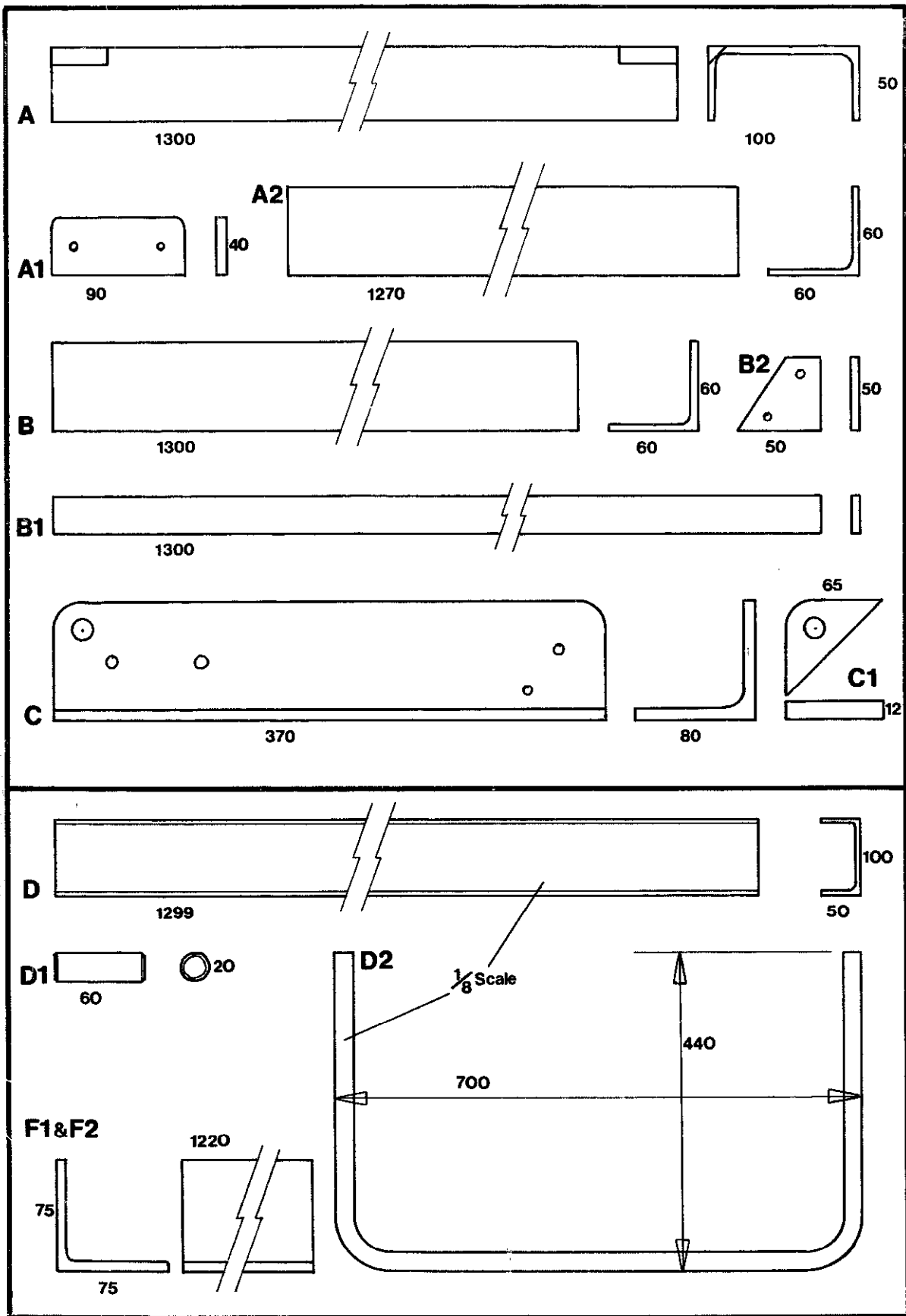
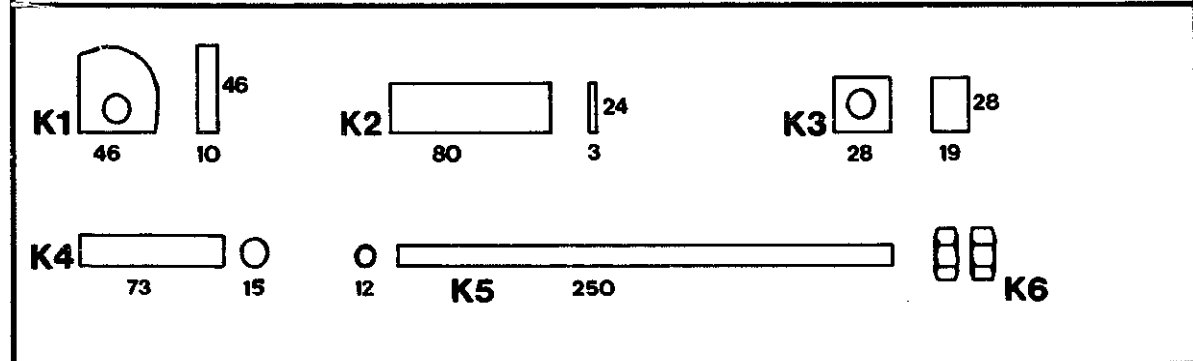
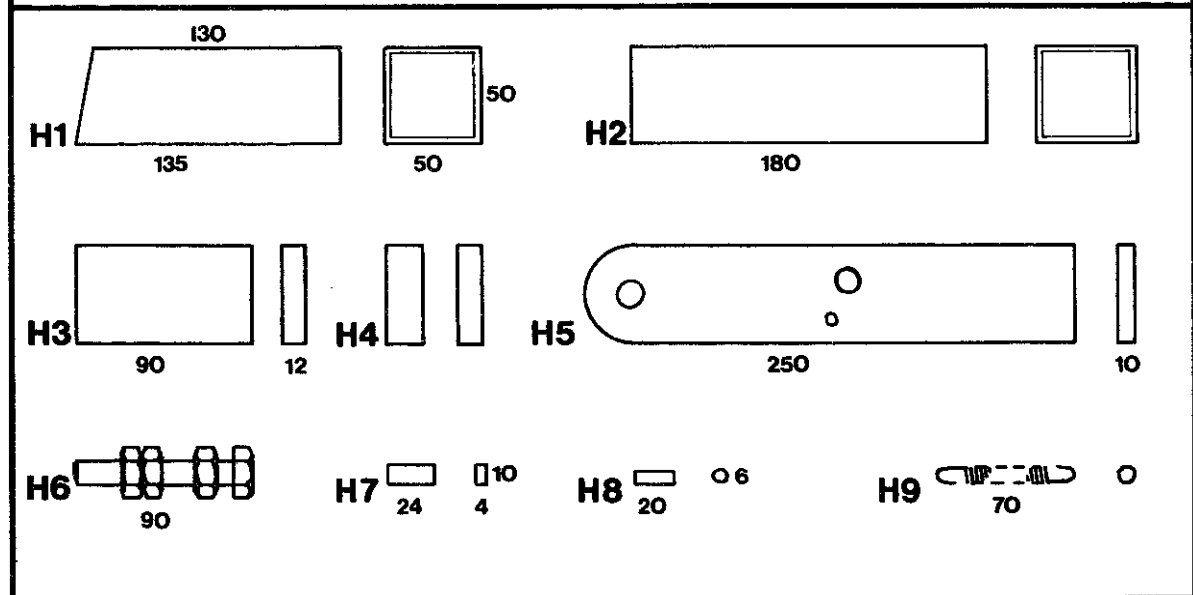
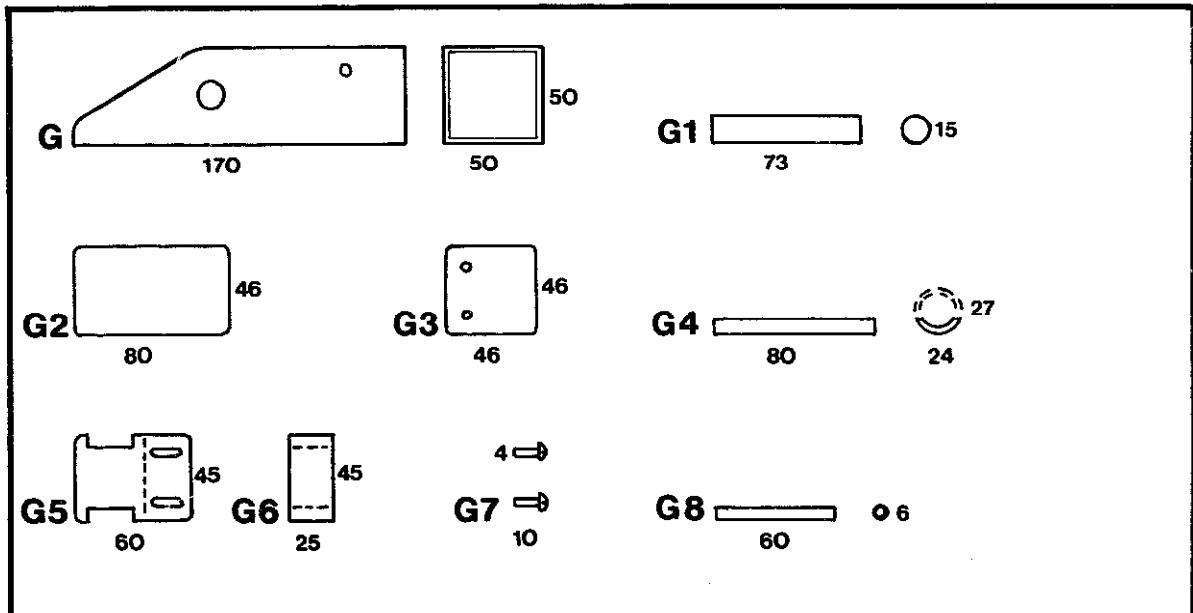

Fig.5

The clamp assemblies G, H and K are designed for quick grip and release action. They are made from 50mm box section (square hollow section, so called). They operate as follows: The lever (K5) is pushed down and turns the cam, causing the clamp rocker to apply pressure to the top of the clamping beam. The result is that point Y puts pressure upwards on the back of the fixed beam channel, and point Z puts pressure down on the clamp side. The fixed beam channel wants to turn but it is held firm by the side mounting plates.



Components D and D2 are drawn here  $\frac{1}{8}$  scale; all the other components are  $\frac{1}{4}$  scale.



**Detail Drawings of Machine Components**

Showing suggested side view and sections.

1/4 scale. Dimensions in mm.

# Construction

## BASE FRAME ASSEMBLY — PARTS

Part	Name	Quantity	Dimensions (mm)
A	Fixed beam	1	100 x 50 x 1300 M.S. channel
A1	Fixed beam end plates	2	90 x 40 x 8 M.S. flat
A2	Fixed beam reinforcing angle	1	60 x 60 x 1270 M.S. angle
B	Clamp slide	1	60 x 60 x 5 x 1300 M.S. angle
B1	Clamp slide cap	1	25 x 5 x 1300 M.S. flat
B2	Clamp slide end plates	2	50 x 50 x 5 M.S. flat
C	Mounting plates	2	80 x 80 x 370 M.S. angle
C1	Pivot blocks	2	65 x 65 x 12 M.S. flat

(M.S. = Mild Steel)

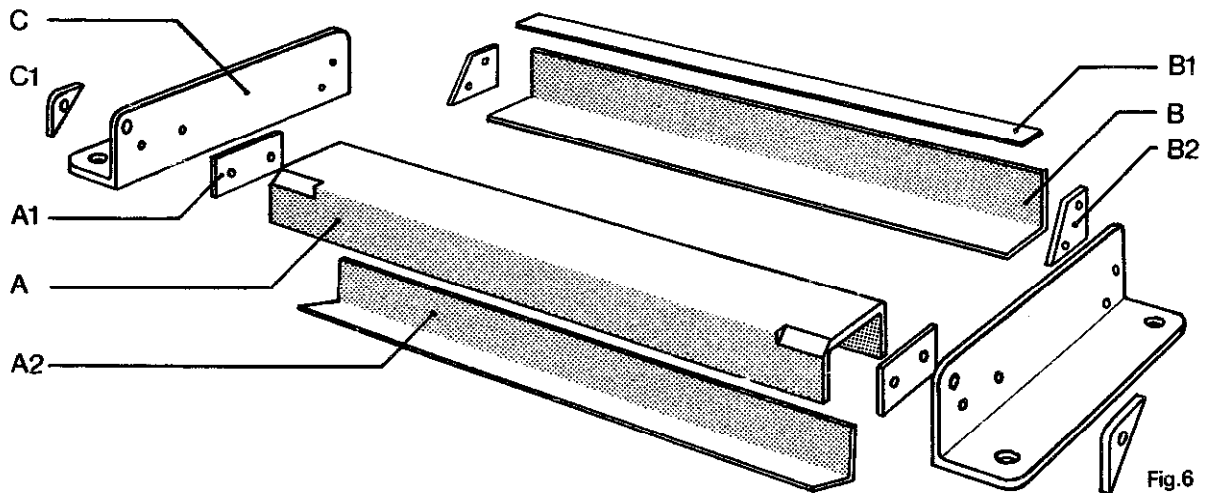
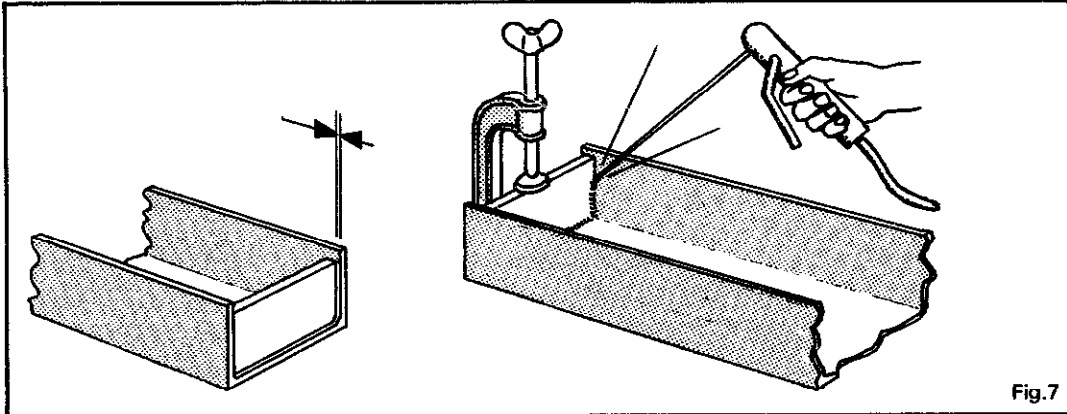

Fig.6

## BASE FRAME ASSEMBLY

Cut channel A, angle B and flat B1 to length accurately and file ends square in all planes. Cut end plates A1 and file to fit inside channel. Clamp in position just short of channel end and weld in place on inside only. Do not drill and tap yet.



Mark out and cut pivot recesses. File smooth.

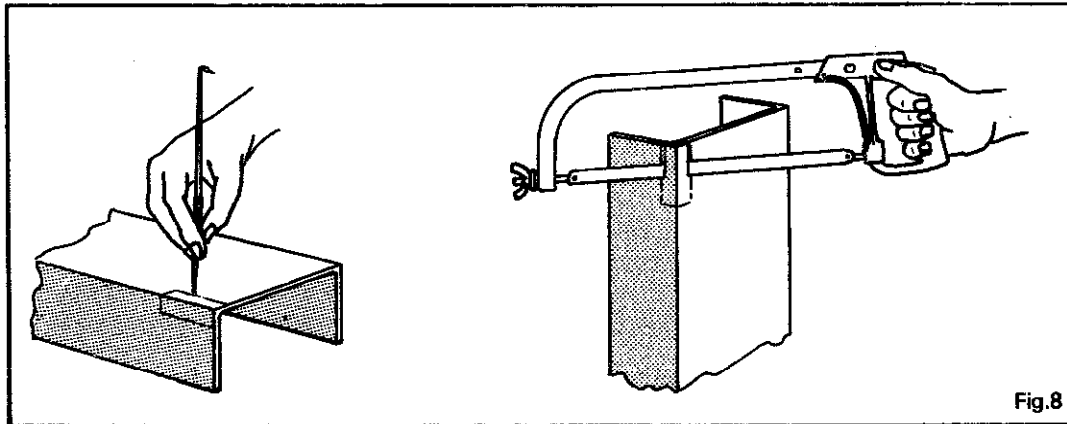

Cut angle A2 to fit in between end plates. Study cross section (Fig.9) to see how this fits. Position carefully and 'stitch weld' in place.

**'Stitch weld'** — That means put short runs of welds (approx. 25mm) at intervals of about 80mm (in this case).

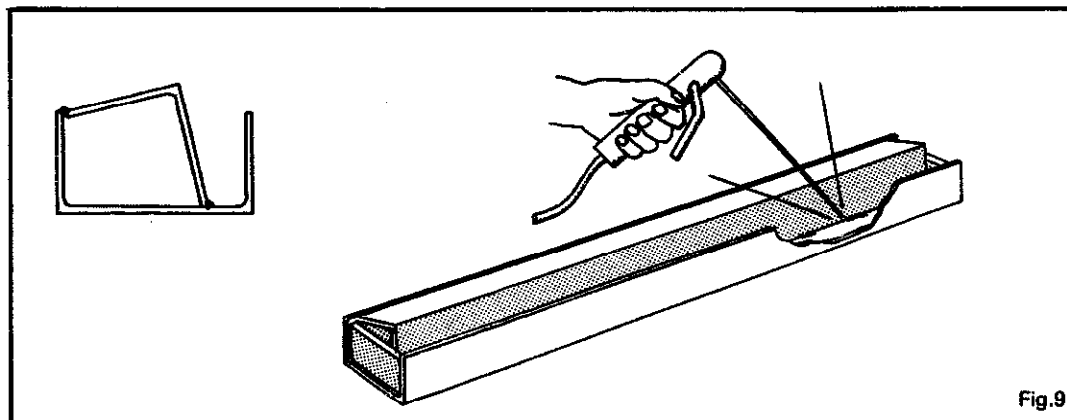

Mark out and cut clamp slide end plates (B2) and file to fit inside angle B with flat B1 resting on top. Take a piece of 50 x 50mm square hollow section (the same as will be used for the clamp base H1 and H2) to make sure that it will slide along between angle B and flat B1, pack with thin steel and clamp. Position the end plates slightly in from the end of the angle (1mm will do). Clamp, and weld on inside. Stitch weld flat B1 on to angle B. Do not drill and tap end plates yet.

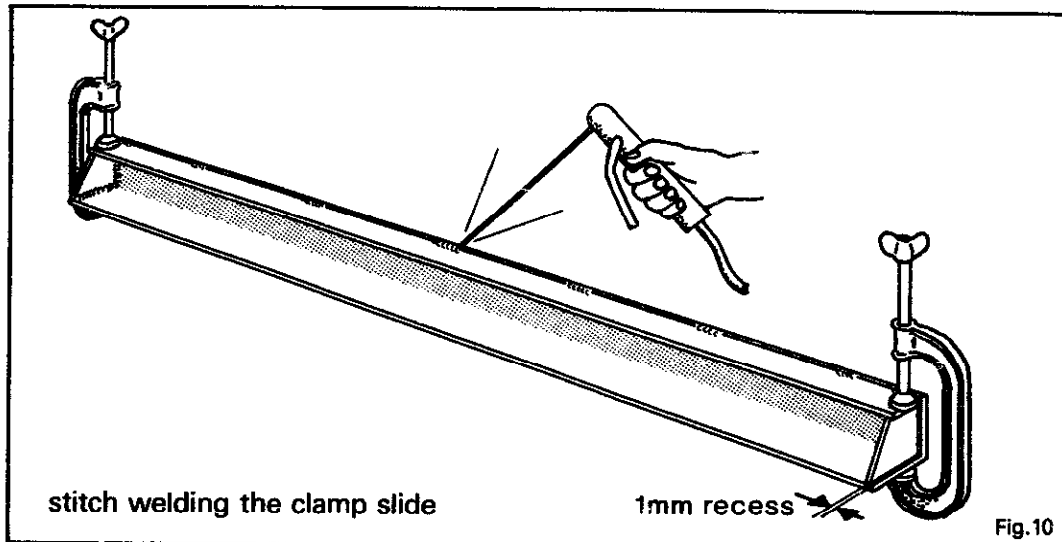

Mark out accurately and cut the mounting plates C. Centre punch and drill all holes with 3mm drill.

**Note:** Do not enlarge the holes yet.

Mark out pivot blocks C1. Drill hole 3mm, cut out and clean up edges. Clamp to mounting plates and locate hole with piece of 3mm dia. rod. Weld front and top edges only.

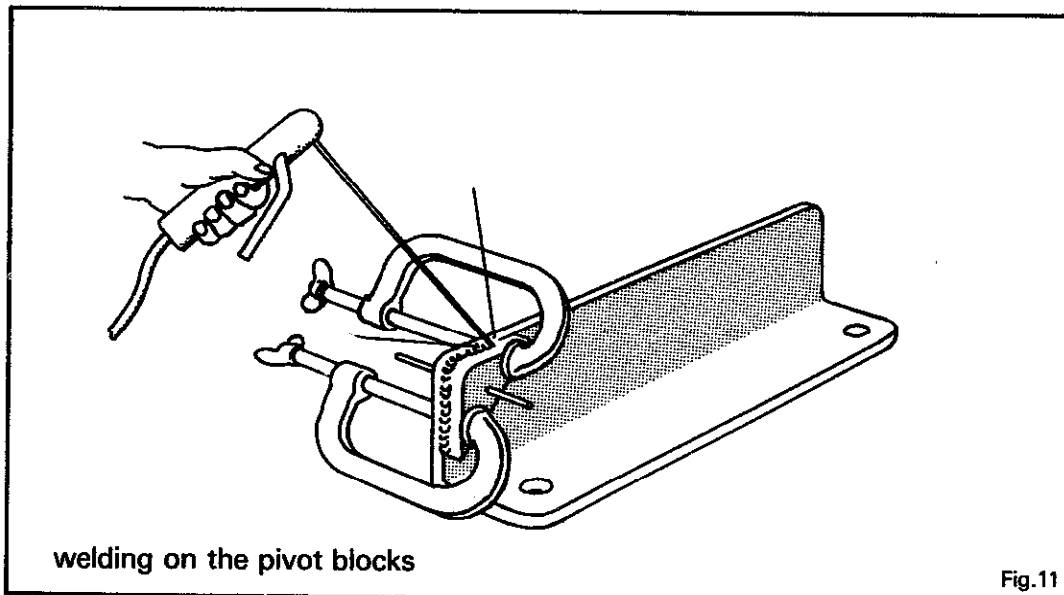

Mark out on the end plates the positions for the ends of the fixed beam, and the clamp slide.

Set up the base frame assembly using packing and clamps, and ensure that:

- all ends are in position;
- the two mounting plates are in the same plane (look along them from one end as indicated);
- the top of the fixed beam is level with the underside of the flat B1;
- **most important** – a 3mm drill inserted in the pivot hole lines up exactly with the corner of the fixed beam (Fig.12). Tap up the fixed beam gently with the hammer until this position is exact, then tighten clamps.

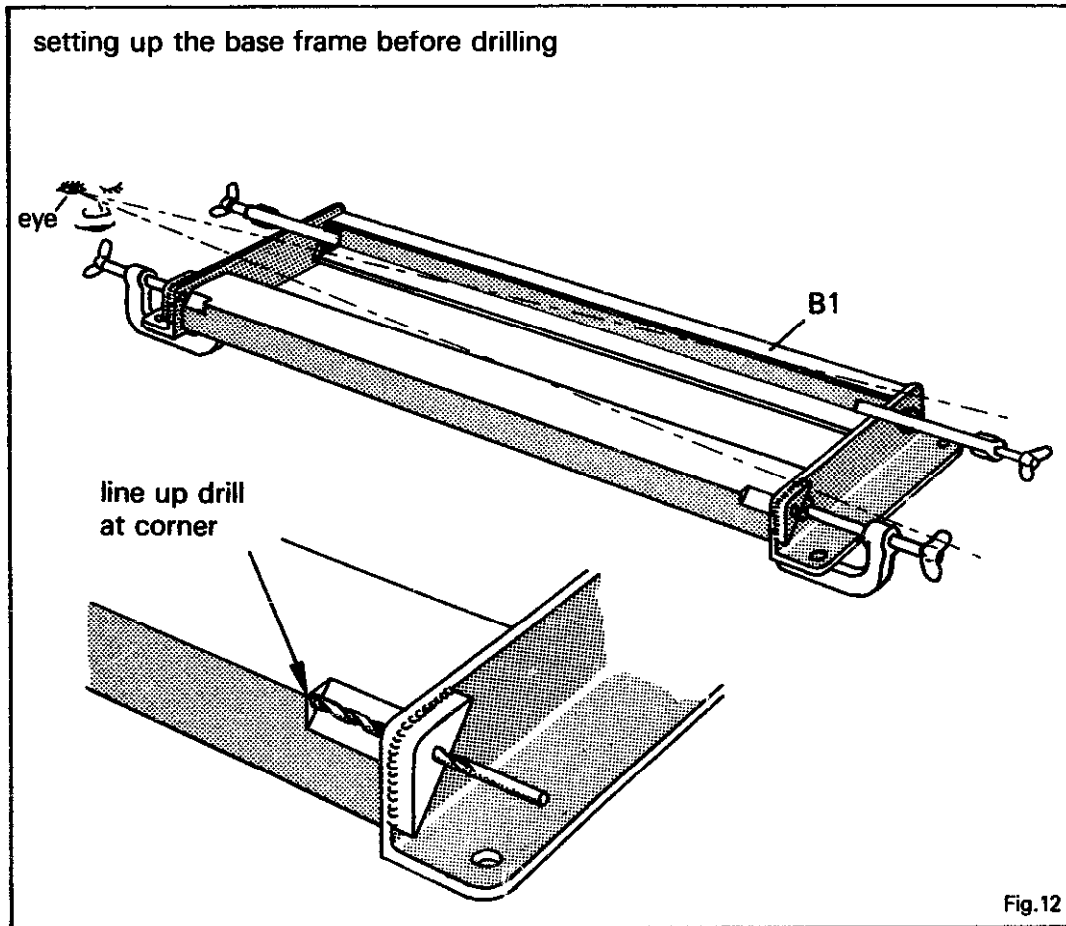

Tack weld in place if necessary in order to remove clamps for drilling. Drill holes through into end plates A1 and B2. Break tack welds with chisel and clean off. Remove all clamps. Drill and tap holes in end plates A1 and B2. Drill to size all holes in mounting plates C.

**Note:** Take care that the pivot hole is accurate and at right angles to the mounting plate. (Sharpen drill first, and use slow speed and lubricant). Check that you have a piece of round bar for the pivots the same size as you are drilling. Check now that the base frame assembly will bolt together properly. File holes out slightly only if necessary. Leave assembled.



## FOLDING BEAM ASSEMBLY — PARTS

Part	Name	Quantity	Dimensions (mm)
D	Folding beam	1	100 x 50 x 1299 M.S. channel
D1	Pivot pins	2	20 dia. x 60 M.S. rod
D2	Folding beam handle	12	25 nominal bore pipe M.S.

See diagram on page 7

dia. = diameter

### FOLDING BEAM ASSEMBLY

Cut main channel D and file ends square. Check that it fits easily between the mounting plates on the base assembly. Mark out and cut recess for pivot as indicated. It is best to cut on the short side and file the pivot pin slightly as needed.

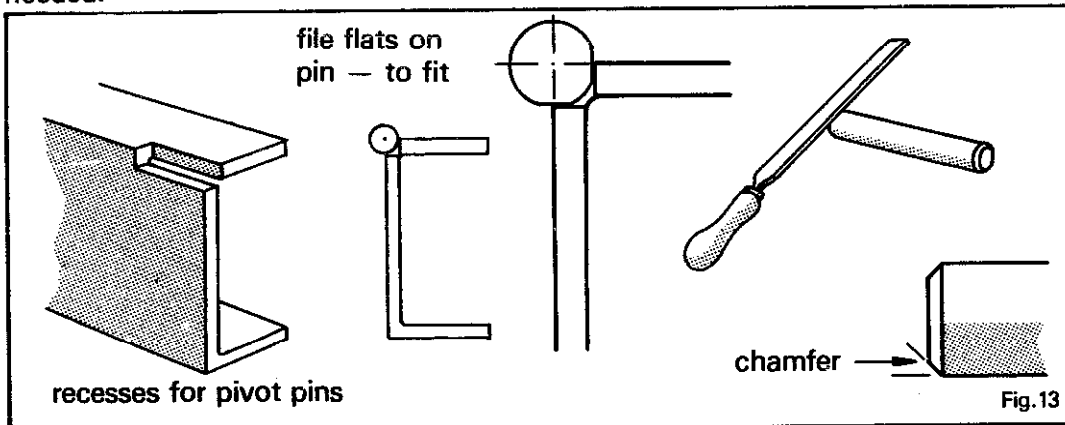

Cut the two pivot pins D and chamfer ends.

Position pins in holes in pivot blocks, and offer up the folding beam D. File pivot pins until the two tops of the beams are level, and the front faces touch when the folding beam is held in place. Clamp in position and tack pins to beam D.

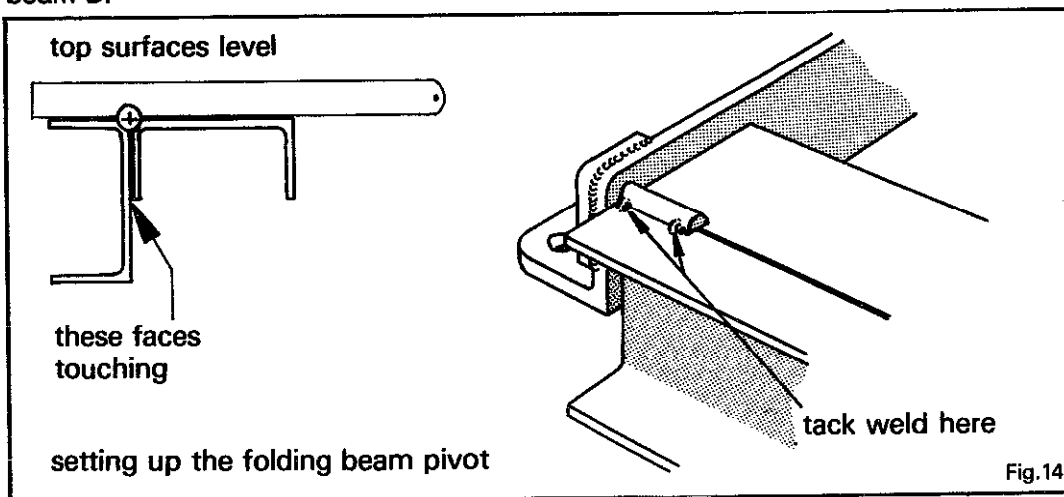

Unbolt one end mounting plate, and remove the folding beam. Complete the welds holding the pivot pins. (Make sure these are strong, especially at the outer ends of the folding beam). Refit the folding beam into the base frame and ensure that it will rotate freely, and come to rest right up against the fixed beam. Grind welds and/or fixed beam to accommodate welds as necessary.

**Handle** — If pipe-bending equipment is available the handle can be made as shown. If not, the handle can be made up either by using some pre-bent tube already available or by welding up elbow pipe fittings. Alternatively, the down tubes can be square section and the cross piece round.

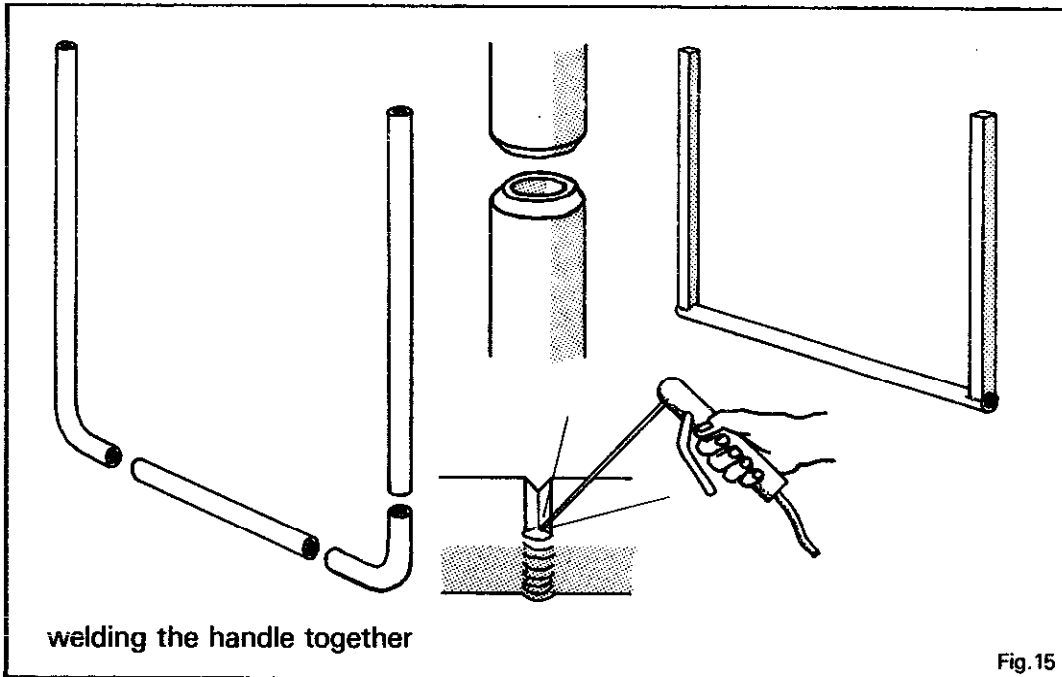

Locate the handle centrally on the folding beam, and weld in place. Build up a good strong weld as this is a point of stress.

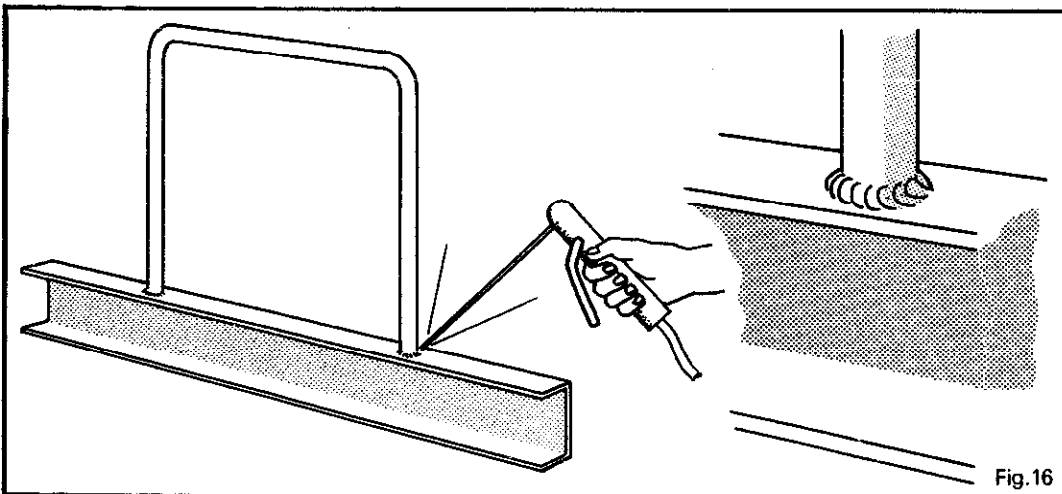

**CLAMPING ASSEMBLY —  
sub-assemblies**

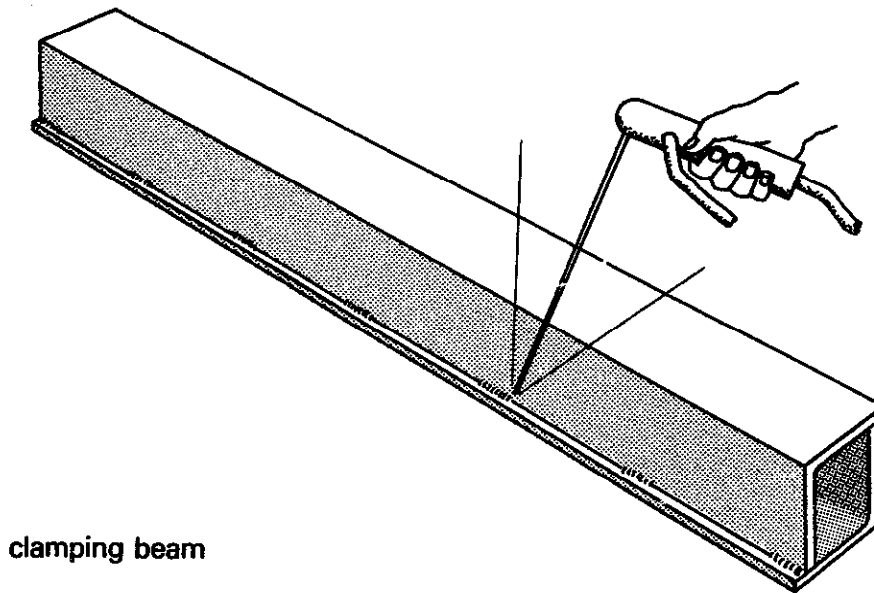
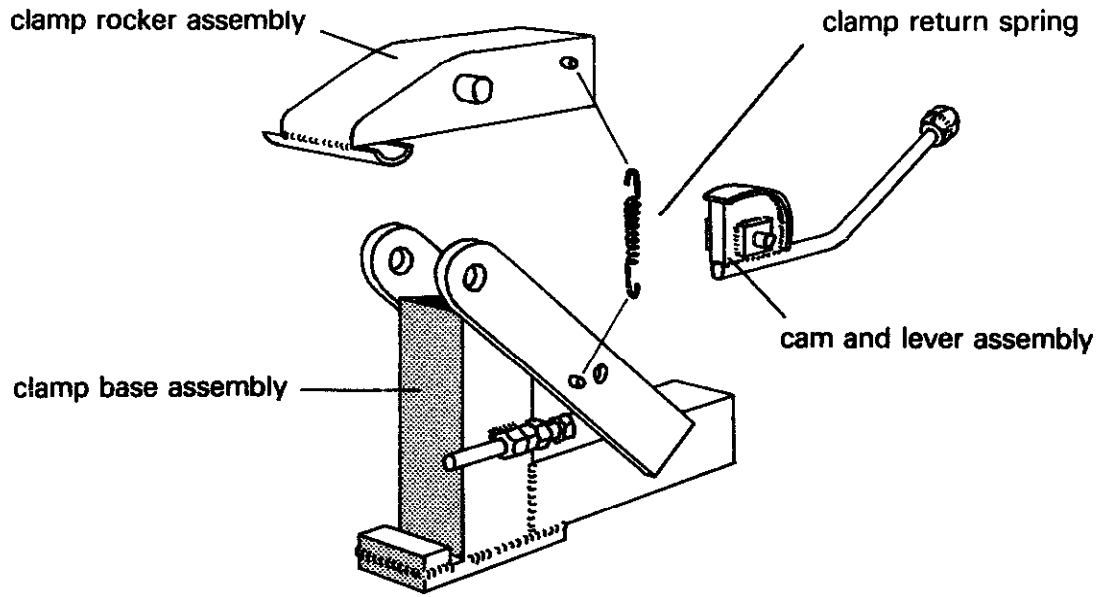

**clamping beam**

**Fig. 17**

## CLAMPING BEAM — PARTS

Part	Name	Quantity	Dimensions (mm)
F1	Clamping beam top half	1	75 x 75 x 1220 M.S. angle
F2	Clamping beam bottom half	1	75 x 75 x 1220 M.S. angle
F3	Stop screw spacers	2	as required

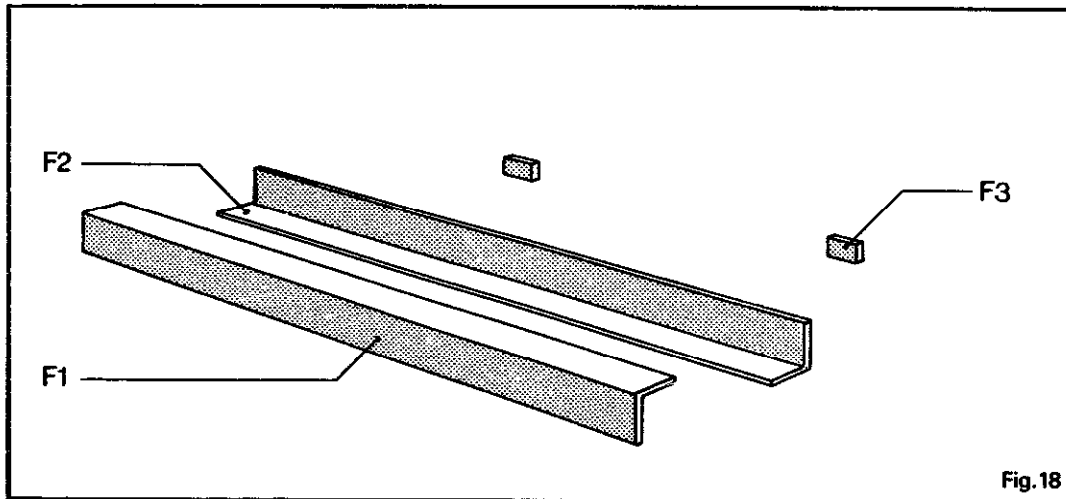

**F The clamping beam** — Cut the two pieces of angle F1 and F2. Position off set and stitch weld as indicated. Put in vice or clamp to any sensible fixed object, and grind or file the leading edge *p*. Check that it is still straight, and correct as required.

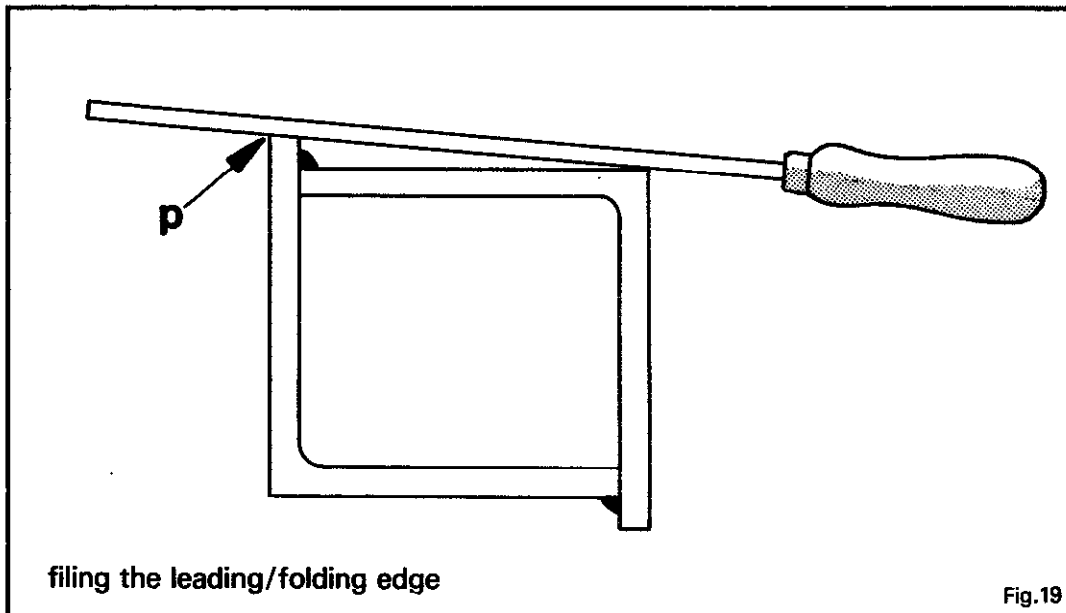

filing the leading/folding edge

Fig.19

**CLAMP ROCKER ASSEMBLY —  
PARTS**

Part	Name	Quantity	Dimensions (mm)
G	Rocker body	2	50 x 50 x 170 M.S. box
G1	Rocker pivot	2	15 dia. x 73 M.S. Rod
G2	Rocker top cap	2	80 x 45 x 2 M.S. plate
G3	Rocker end cap	2	46 x 46 x 4 M.S. plate
G4	Clamp foot	2	piece of 27 O.dia. pipe x 80
G5	Cam follower	2	see drawing on page 11
G6	Shim	2	see drawing on page 11
G7	Screws	4	4 dia. U.N.C. x 10
G8	Return spring pin	2	6 dia. x 60 approx M.S. rod

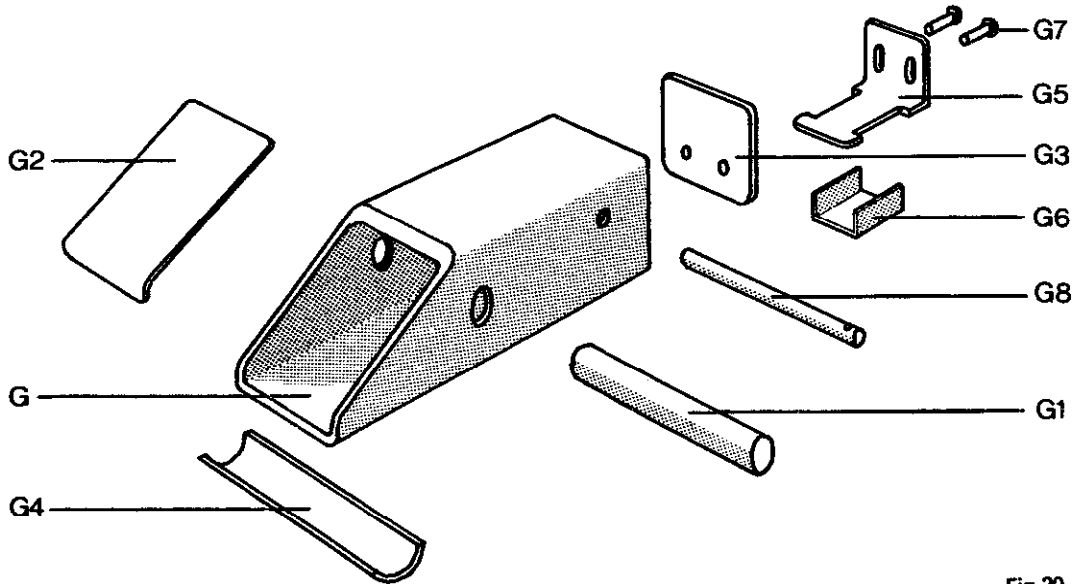

Fig.20

**CLAMP ROCKER ASSEMBLIES**

Remember to make two of each part whilst marking out and cutting. The following describes the fabrication of one rocker.

Cut the 50 x 50mm square hollow section as shown and drill the holes for the pivot G1. Cut the pivot G1 and position through the rocker, with equal amounts protruding each side. Weld it in place from inside at the front. Cut, bend and file a piece of 2mm plate to fit the front opening and weld in.

Cut a piece of water pipe and file to size shown. Position centrally at tip of rocker and weld front and back.

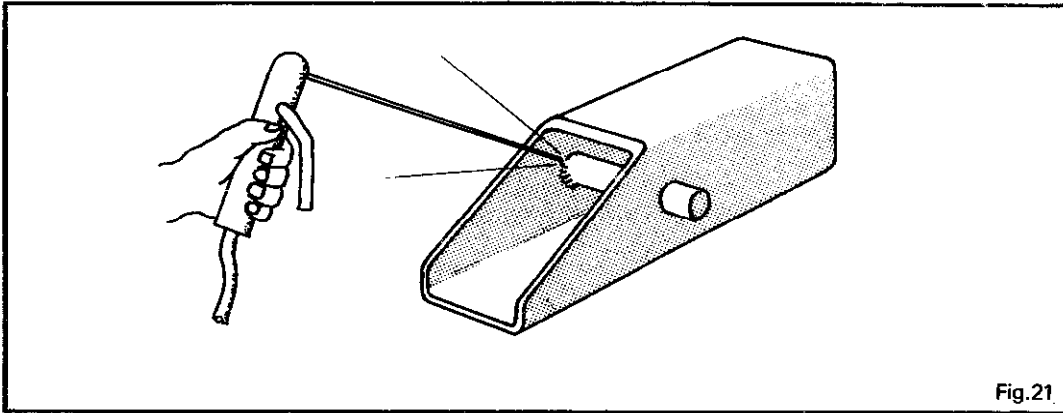

Fig.21

Cut and file a piece of 3 - 4mm plate to fit the back opening, and drill and tap as shown. Fit and weld.(Put screws G7 in whilst welding to avoid getting weld in the threads).

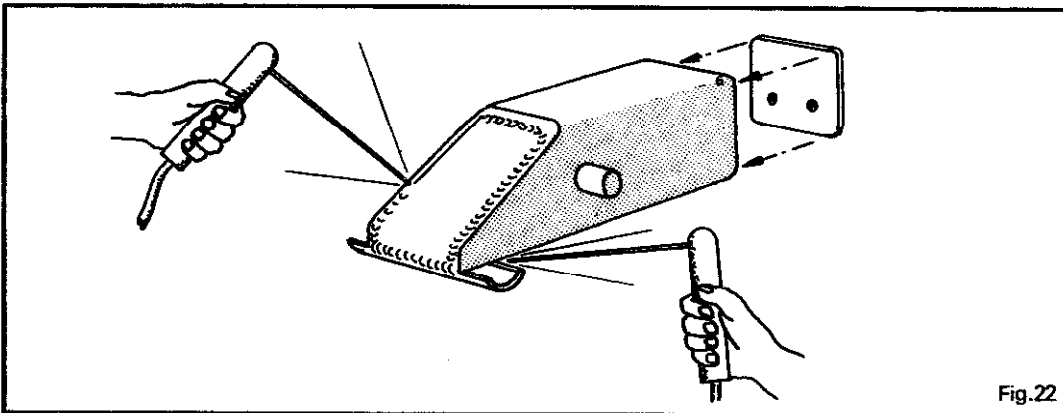

Fig.22

Make up cam follower from 1.5mm steel sheet, and drill and file elongated holes. Cut piece of brass sheet G6 and wrap around G5.

**Note:** This brass shim can be packed out with more brass or steel shim to increase the clamping pressure. It is also easily replaced if wear occurs.

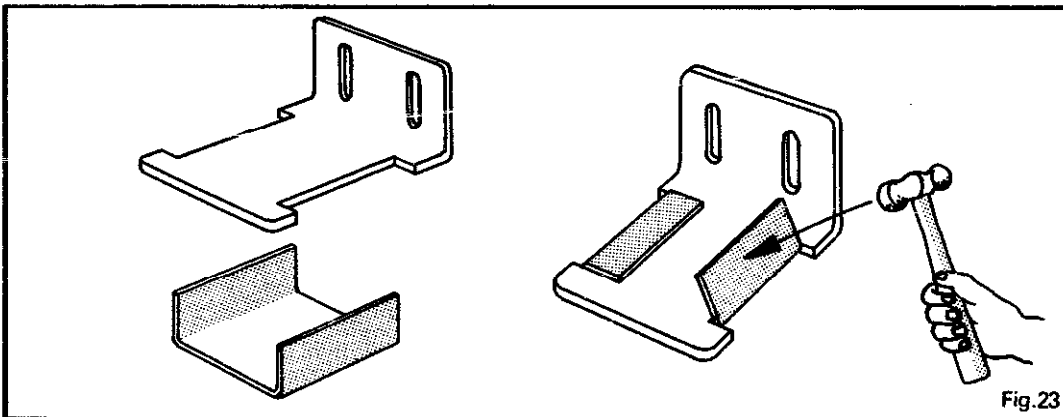

Fig.23

## CLAMP BASE ASSEMBLY — PARTS

Part	Name	Quantity	Dimensions (mm)
H1	Clamp base column	2	50 x 50 x 135 M.S. box
H2	Clamp base foot	2	50 x 50 x 180 M.S. box
H3	Clamp base tongue	2	50 x 12 x 90 M.S. flat
H4	Clamp base lip	2	50 x 12 x 18 M.S. flat
H5	Rocker pivot supports	4	50 x 10 x 250 M.S. flat
H6	Clamping beam stop screw	2	12 dia. U.N.C. x 90
H7	Stop screw spacer	2	10 x 5 x 25 M.S. flat
H8	Clamp base return spring pin	2	6 dia. x 20 M.S. rod
H9	Rocker return spring	2	10 dia. x 70 approx

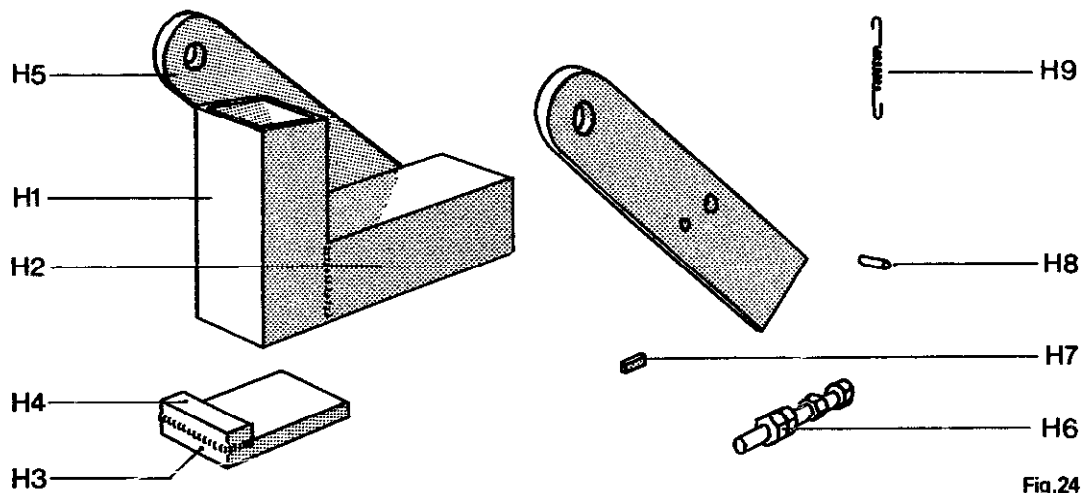

Fig.24

## CLAMP BASE ASSEMBLY

Cut pieces H1 and H2. Ensure front edge of H2 is a right angle. Clamp and weld. (A wood worker's sash clamp is particularly useful for this).

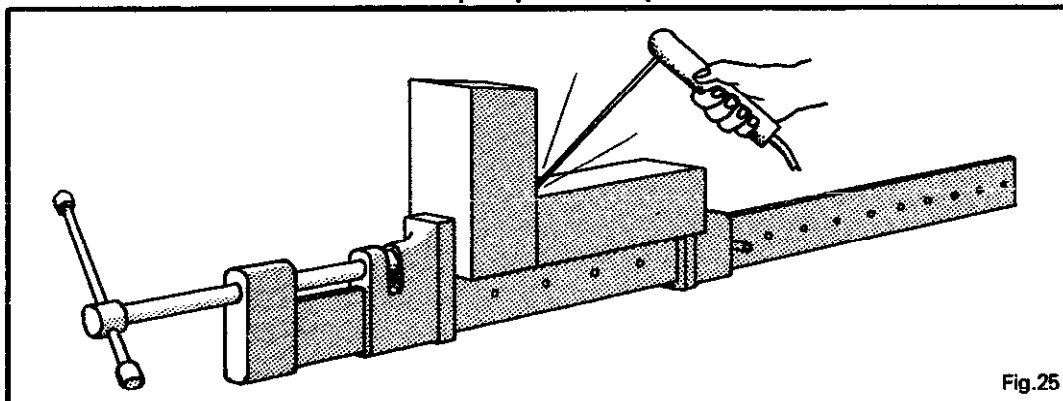

Fig.25

Cut H3 and H4. Clamp together and weld front and side edges. Clamp H3 to H2. Set the distance of the lip H4 from the column H1 by hooking on to the back edge of the channel A. Shown here upside down.

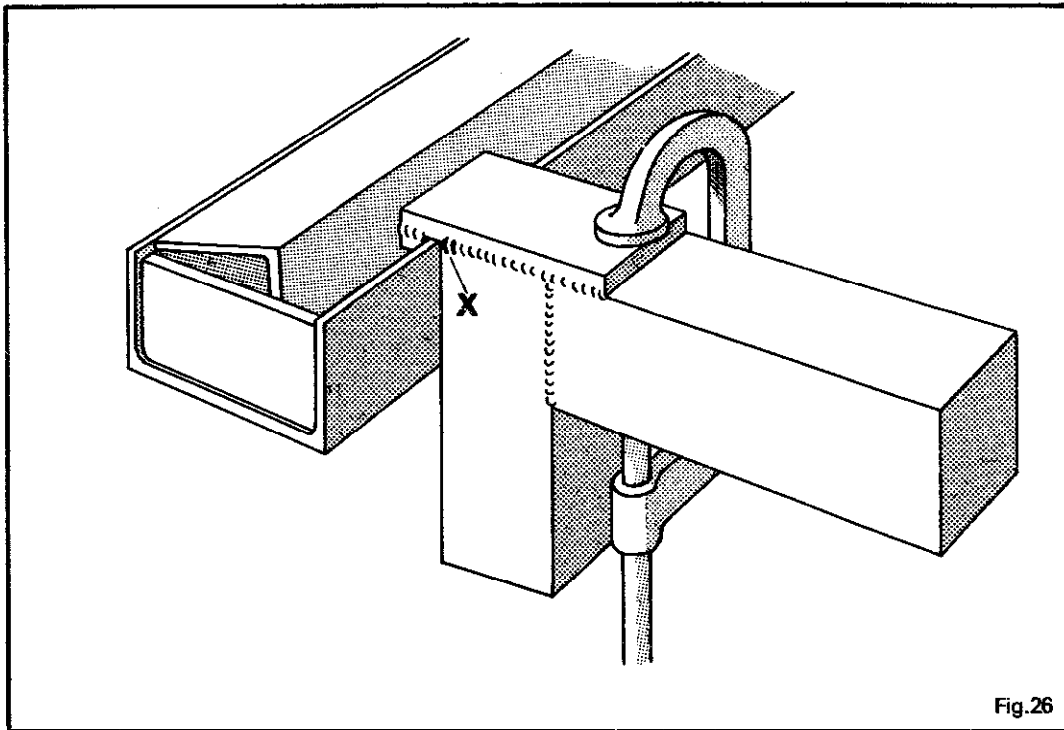

Fig.26

Check that the clamped assembly will slide freely from side to side. Remove assembly from the channel and weld foot on to base both sides, making sure of an extra strong weld at X. Mark out accurately, cut and drill pivot supports H5. Clamp one side to the base and position accurately as indicated. Weld in place. **DO NOT WELD OTHER PIVOT SUPPORT ON YET.**

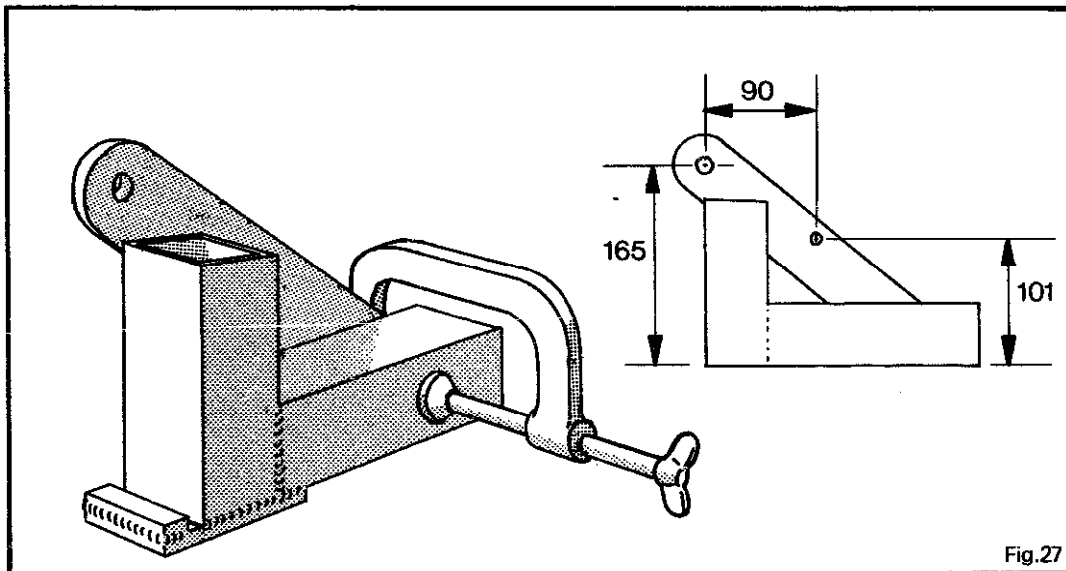
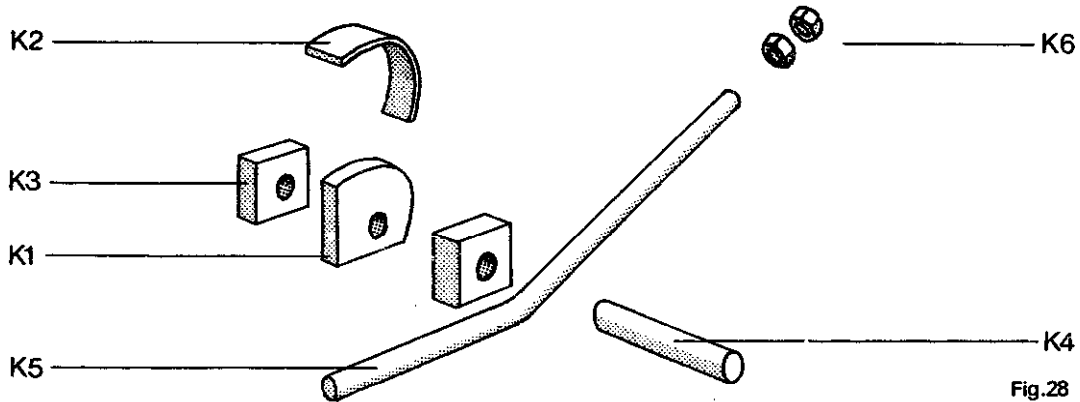

Fig.27



**CAM & LEVER ASSEMBLY —  
PARTS**

Part	Name	Quantity	Dimensions (mm)
K1	Cam	2	10 x 45 x 45 M.S. plate
K2	Cam shell	2	25 x 3 x 80 M.S. flat
K3	Cam spacers	4	28 x 28 x 19 M.S. bar
K4	Cam spindle	2	15 dia. x 73 M.S. rod
K5	Cam lever	2	12 dia. x 250 M.S. rod
K6	Cam handle	4	12 threaded nut



**CAM ASSEMBLY**

Cut out pattern for cam profile. Position pattern on a square corner of a piece of 10mm plate and stick down with tape or clamp on. Centre punch the centre of the cam pivot, and then along the profile of the cam at intervals as shown. Remove pattern and drill hole 3mm and then to size. Cut profile over size and grind almost to line of dots. Finish with a file and check for squareness all round.

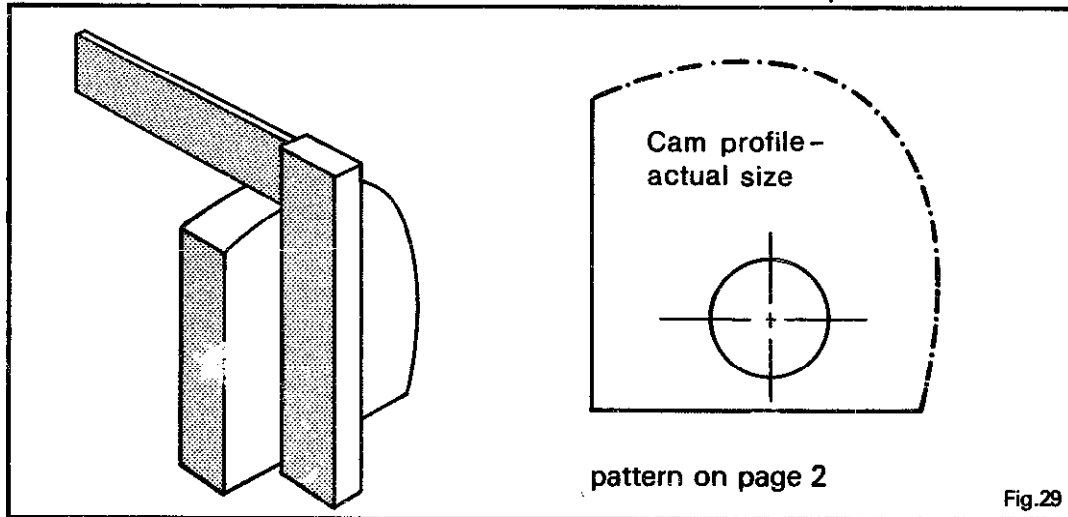

Cut strip for cam shell K2. Position as shown overlapping each side of the cam equally and parallel with the cam when viewed from the end. Tack weld each side.

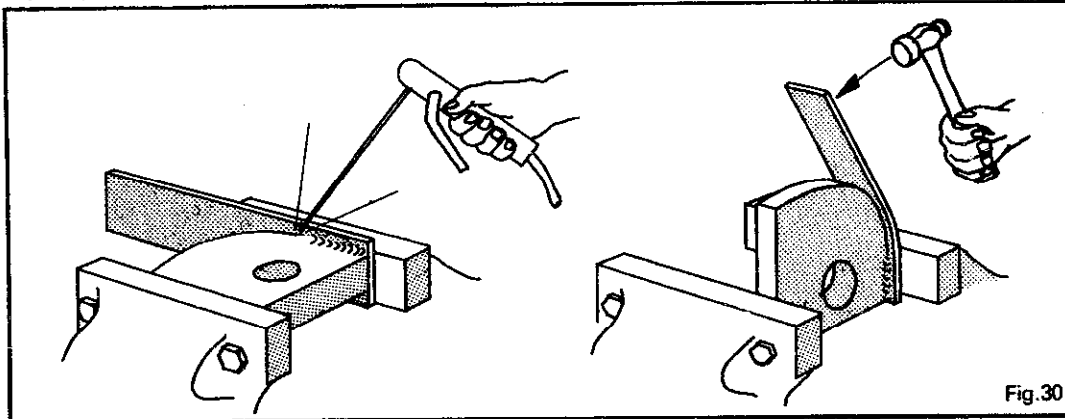

Heat cam shell with a blow torch till red hot, or put in a forge so that only the shell gets red. Clamp in vice and hammer shell round to fit the cam. Clamp tightly round and weld (Fig.30).

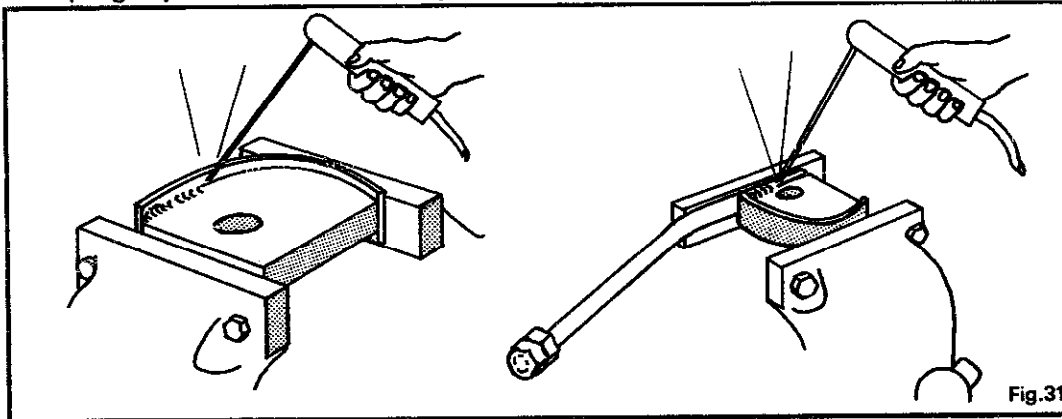

Cut length of rod for lever K5 and find four nuts K6. Bend the lever as shown, and weld the nuts on to the long end. Grind off corners of nuts to make a smooth knob. Clamp the lever on to the cam and weld both sides. Mark out spacers K3 on a bar and drill to size. Then cut off. Cut spindles K4. Assemble spacers and cam on spindles centrally. Weld spacers on to cam.

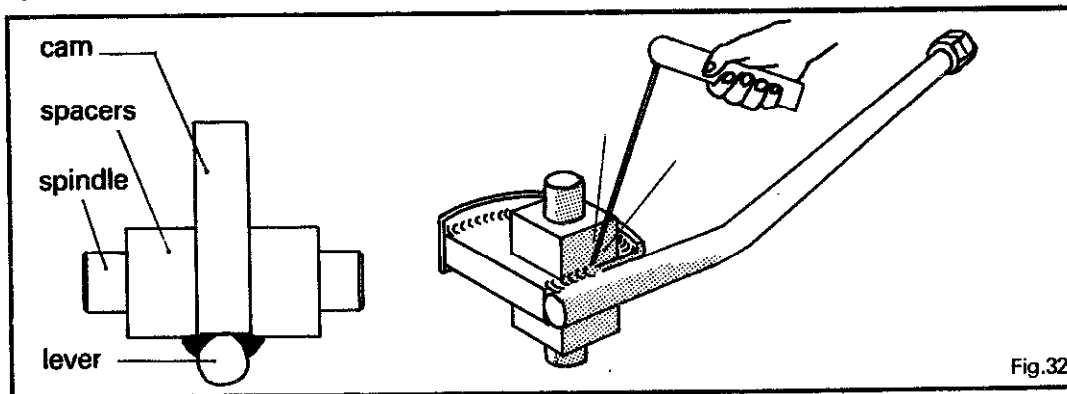

## ASSEMBLY OF CLAMP

Fit the rocker and the cam on to the pivot support H5 which is already welded to the column. (Grease all pivots and holes first). Fit on other pivot support and clamp ready for welding. Check that the cam and the rocker are free to pivot. If not, insert a thin piece of sheet metal (e.g. piece of tin can) between the pivot support and the clamp column and foot.

When satisfied that the cam and rocker are working freely, (and check that the cam does not foul the column), weld as indicated.

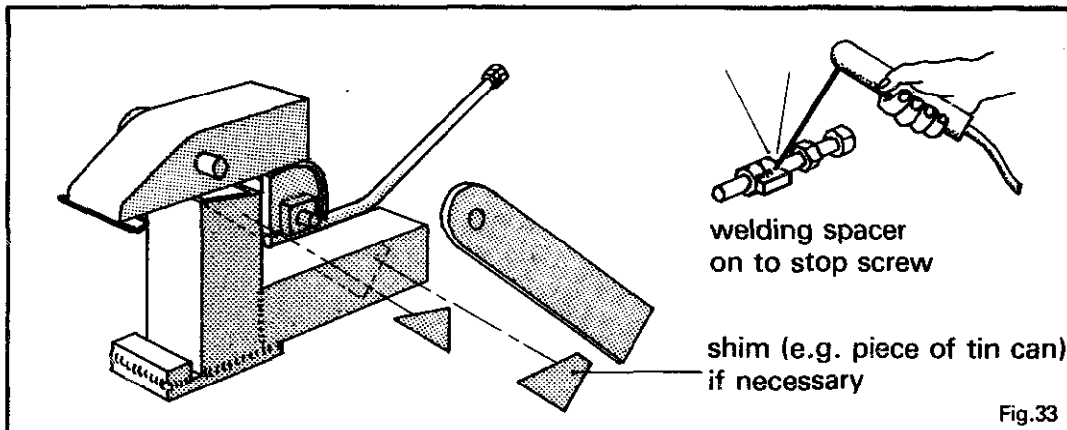

**Stop screw H6** — To complete the clamp assemblies decide on a right hand and a left hand assembly. The left hand one is illustrated (see page 18). Take the bolt H6 and run three nuts down it leaving two of them touching and with the flats lined up. Cut the small spacer H7 and weld it on to the two nuts as shown, top and bottom. Clamp the nuts on to the clamp base column as indicated and weld spacer to the column.

**Note:** Protect the bolt thread from weld splashes with thin tin wrapped round.

The position of the stop screw is critical. If it is too high you will not be able to get a spanner on the bolt head, and if it is too low you will not be able to fit the clamp assembly on to the fixed beam.

**Return spring H9** — Finally cut pins G8 and H8. Cut a small notch about 2mm from one end, to hook the spring on. Pin G8 can be welded flush, on the far side of the rocker. Pin H8 should be made a tight fit and just tapped into its hole in H5, or it can be brazed in. Alternatively, the hole could be drilled and threaded to receive a small bolt with a lock nut. Find or adapt a spring to suit and hook on to pins. Grease the cam shell.

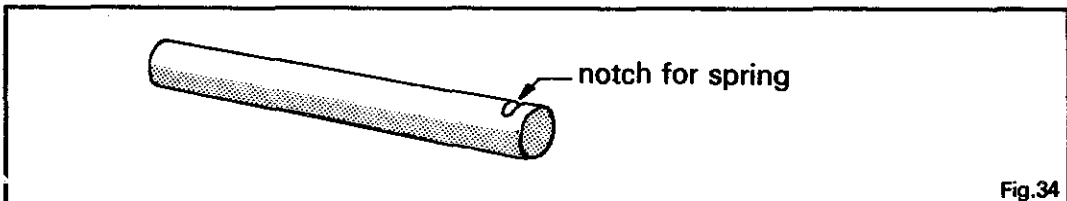

## FINAL ASSEMBLY

Remove the clamp slide from the base frame. With a slight twist the clamp assemblies can be hooked on to the back of the fixed beam. The folding beam and the clamp slide can now be fitted. The machine is now ready for use.

## Operation

Clamp or bolt the base to a suitable bench top. (Ideally a heavy bench or one which is fixed down). Place the clamping beam on top of the fixed beam and under the clamps. Line up the folding edge about 1mm back from the crack between the fixed beam and the folding beam. (This can be adjusted according to the thickness of sheet metal being folded, and the tightness or corner required).

At this point it may be necessary to fit spacers F3 on the back of the clamping beam, where the adjusting screws are to operate. If so, tack weld to clamping beam.

Mark out sheet metal to be folded. Felt tip (spirit ink) pens are ideal for galvanized sheet. Insert the sheet between clamping and fixed beam, until the line is just in front of the folding edge. Push clamp handles down. Raise folding beam handle till required bend is achieved.

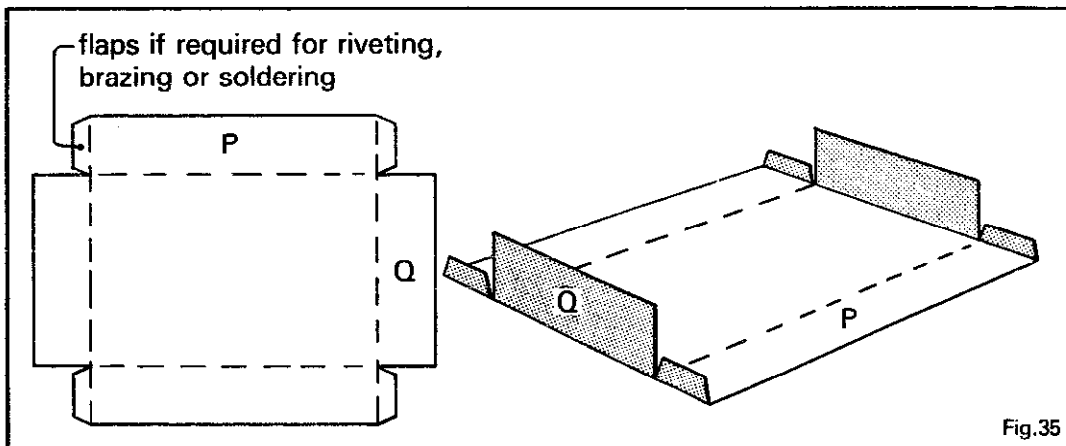

### How to fold a pan

A special purpose clamping beam will have to be made up for each size of pan you require to make. Bearing this in mind, decide the dimensions for your pan, and mark out on the sheet metal to be used.

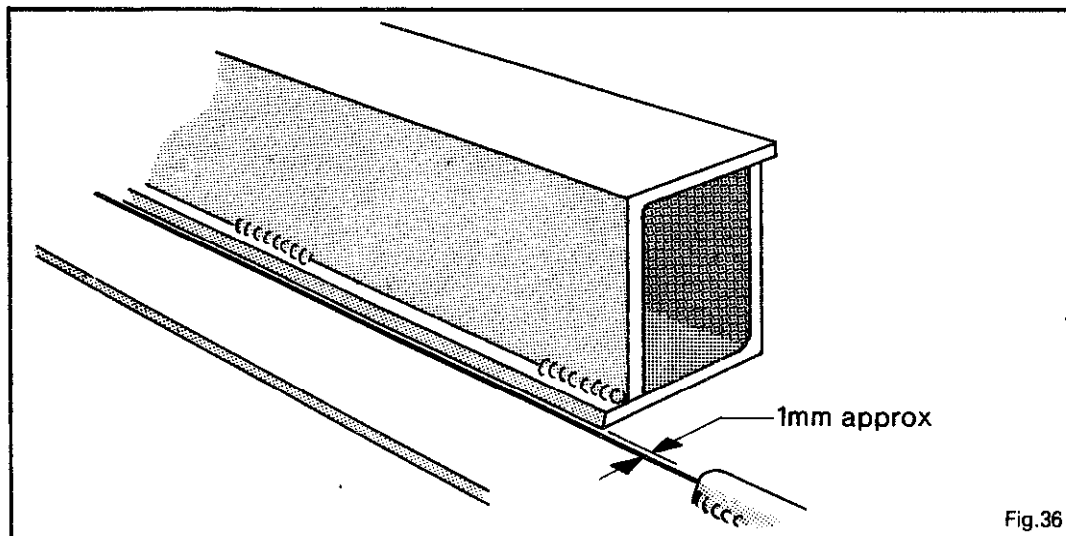

### For a single pan

The sides with the flats on the same fold line must be bent first (side Q).

This can be done as described on page 27.

The flaps must now be hammered slightly on a sharp metal corner (e.g. angle iron on bench edge), with a strip of sheet metal tacked in place as shown.

A clamping beam the width of P must now be made or adapted. Side P can now be inserted between the special length clamping beam and the fixed beam, and the box/pan bent up as far as it will go. An absolute right angle cannot be achieved as the sides Q prevent this. Finish off the bend with a hammer, preferably over a hard edge.

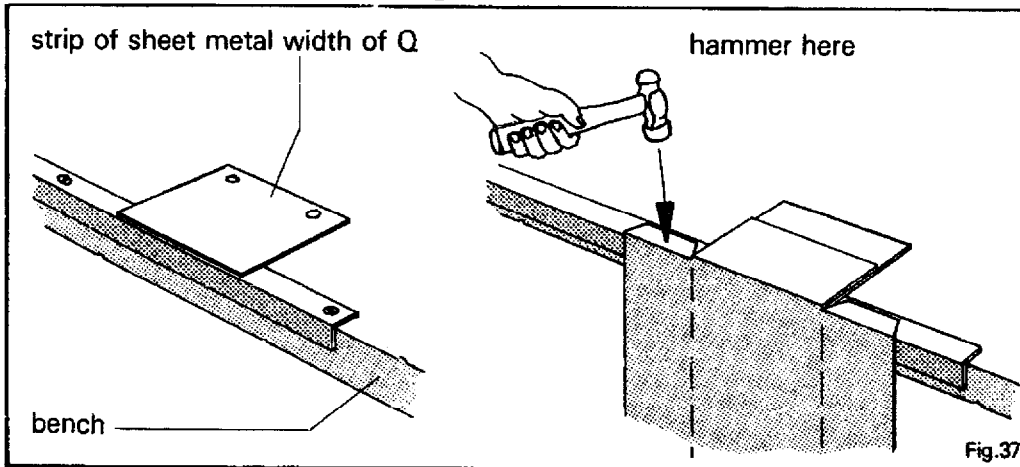

### For a number of pans the same size

If many boxes/pans the same size are required, and they need tongues on the corners, the folding machine can be adapted to put the offset on the tongues in one go.

Tack weld strips of metal as indicated, and take care to line them up with the sheet being bent.

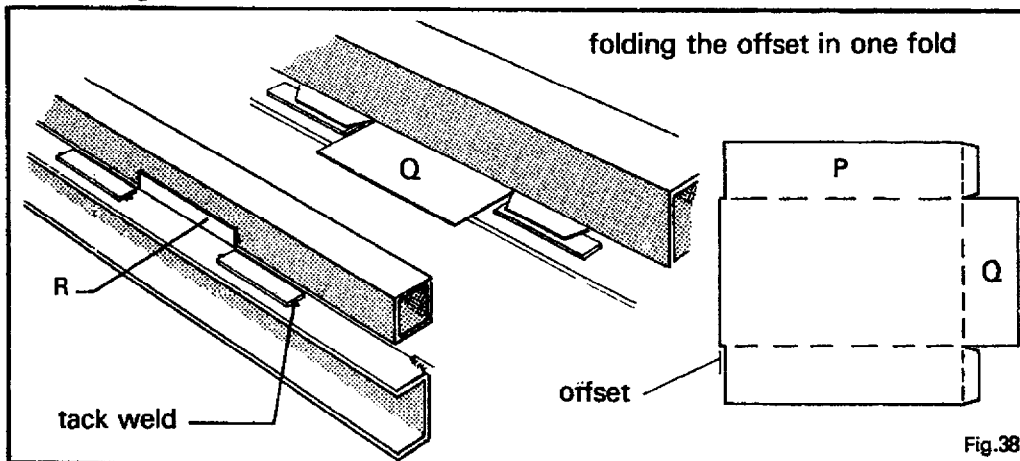

Slacken off the adjusting screws to line up the front of strip R about 1mm behind the front edge of the fixed beam. Put the base of the box/pan right under the clamping beam and fold up the end Q. The result will be the offset required. Bend P as before.

## Optional designs

### Folding beam

If it is required to bend return folds as shown, it will be found that the folds cannot be made any closer together than the width of the folding beam (i.e. 50mm).

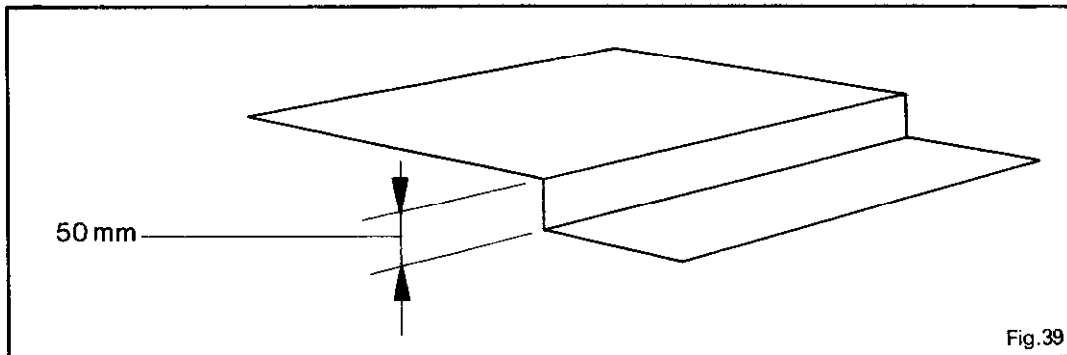

Fig.39

In order to do closer return folds, the following alternative folding beam can be made:

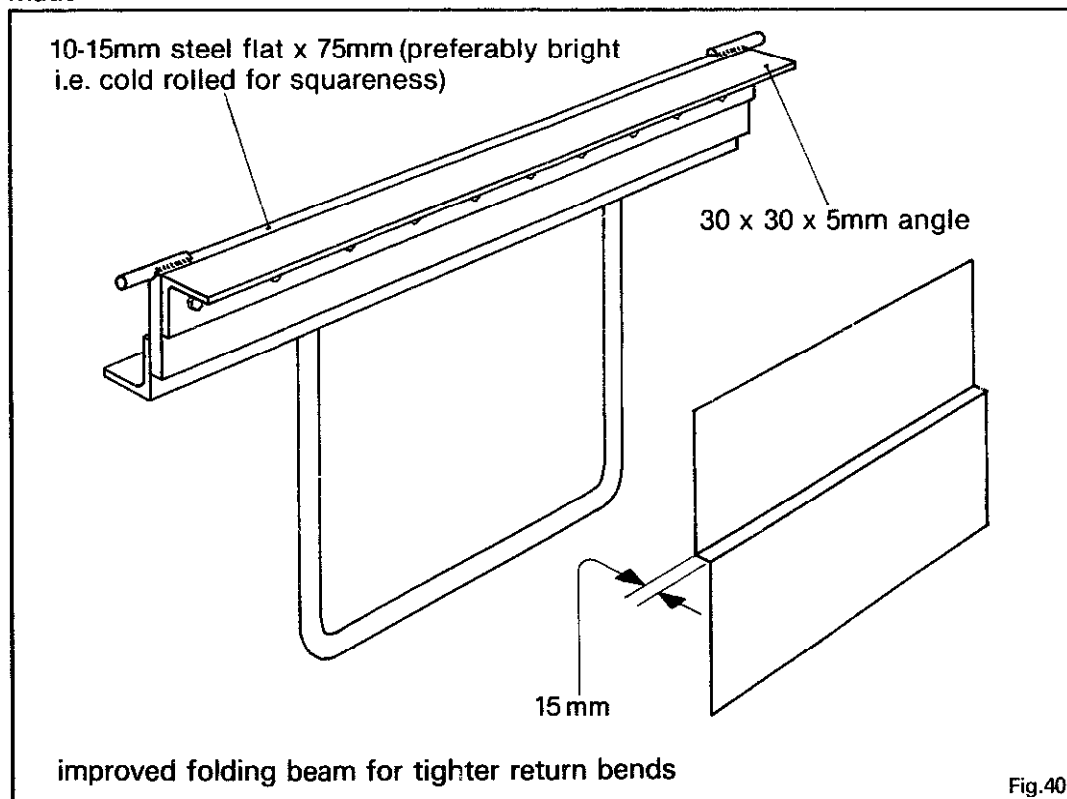

Fig.40

Stitch weld the bottom angle to the flat, taking care to avoid distortion (i.e. weld inside and outside at same place alternately and put more welds on the outside rather than the other way round). This folding beam can be used as normal, but the angle can be removed to do close return bends in light gauge metal. This set-up is ideal for car body work, sills etc.

**To bend deeper pans**

The design detailed in this book will only accommodate pans/trays of depth up to 100mm. To increase this capacity up to 150mm the clamps can be constructed as follows:

- With clamp pivot plates cut from solid 10mm plate (Fig.41).
- With fabrication of 10 x 50mm flat (Fig.42).

Fig.41

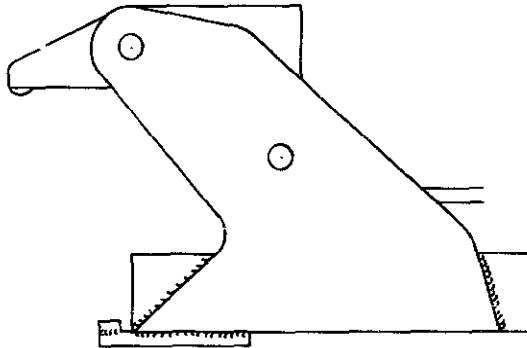
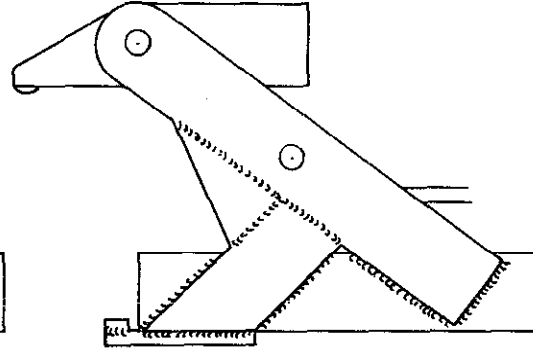
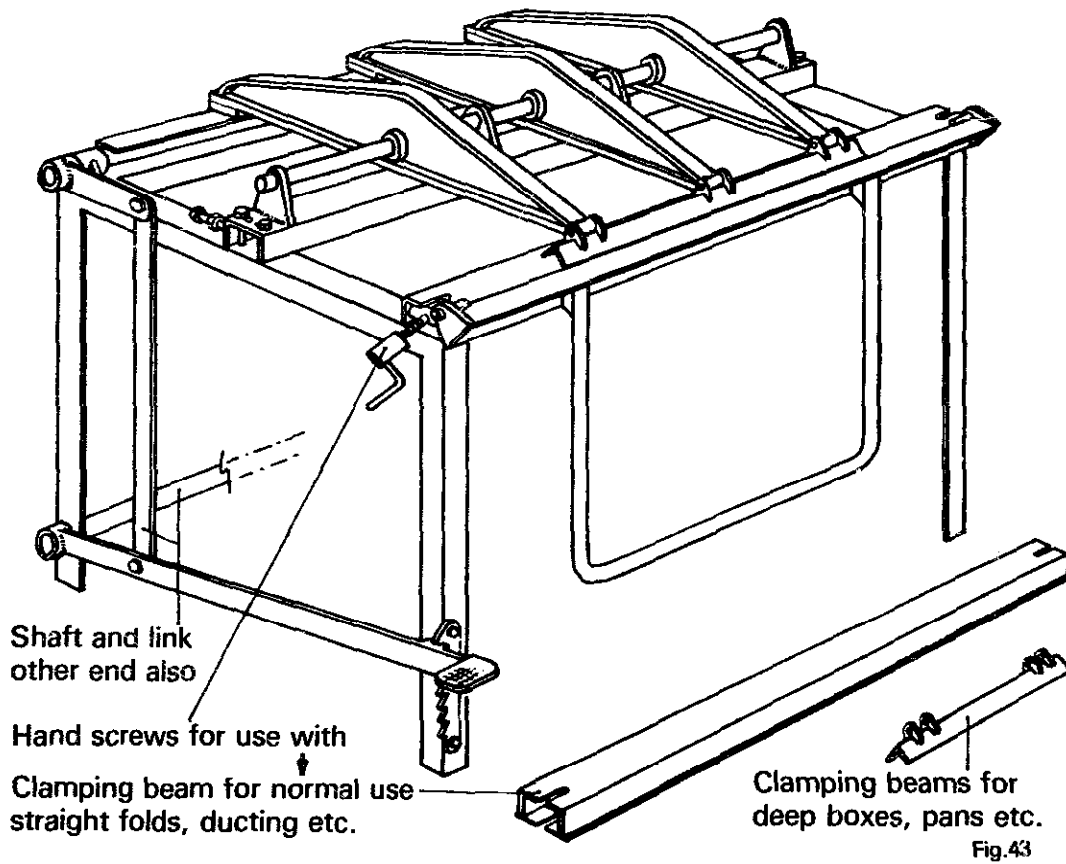

Fig.42



Alternatively, if even greater depth is required, the clamp system can be re-designed perhaps along lines similar to this.



### Self raising clamping beam

In order to make it easier to slide in the sheet metal to be bent, the clamping beam can be made automatically self raising when the clamps are released. Two small hooks can be welded on to the top of the clamping beam at each end, to locate on the clamp foot G4. The springs H9 pull the clamp rocker down at the back and so raise the clamping beam up at the front.

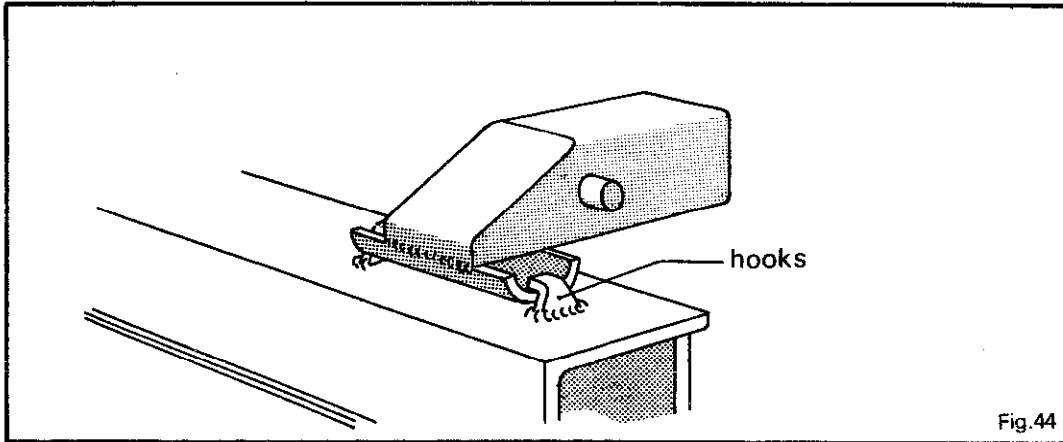

### Bending radius curves on sheet metal

Special clamping beams can be made up to fold curved corners as illustrated.

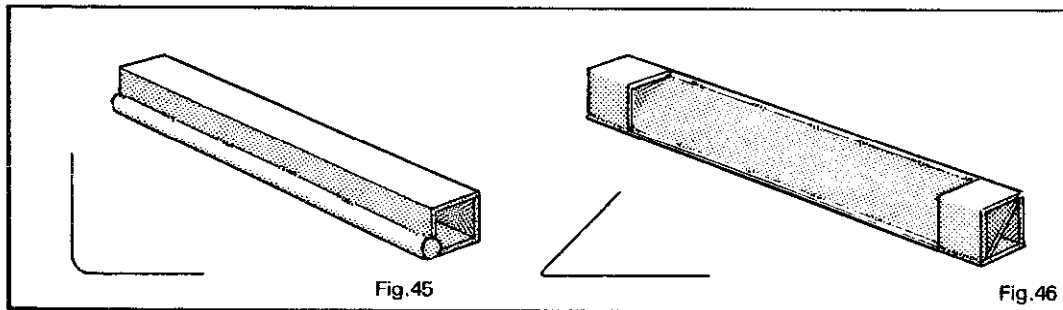

### Folds greater than 90°

Special clamping beams can be made to enable folds to be made up to 135°, using a similar fabrication as shown (Fig.46).

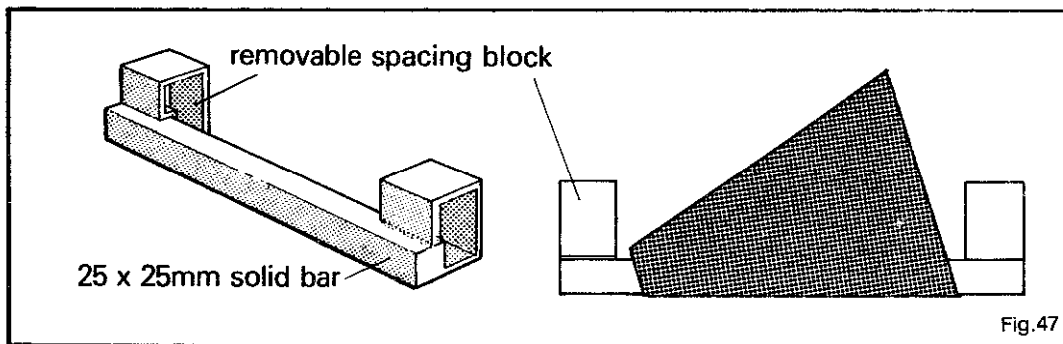

### Funnels

If it is required to fold funnels with a small hole at one end, a clamping beam as shown will handle thin sheet quite well. Remember to make one end removable so the funnel can be slid off.