

AT MICROFICHE REFERENCE LIBRARY

A project of Volunteers in Asia

Appropriate Technology: Directory of Machines,
Tools, Plants, Equipment, Processes, and
Industries

Published by:

Appropriate Technology Development Association
P.O. Box 311 Gandhi Bhawan
Lucknow 226 001, U.P.
India

Paper copies are \$10.00; please add enough to
cover postage to your country.

Available from:

Appropriate Technology Development Association
P.O. Box 311 Gandhi Bhawan
Lucknow 226 001, U.P.
India

Reproduced by permission of the Appropriate
Technology Development Association.

Reproduction of this microfiche document in any
form is subject to the same restrictions as those
of the original document.



Appropriate Technology

**Directory of Machines,
Tools, Plants, Equipments,
Processes & Industries**

**Appropriate Technology Development Association,
Post Box 311, Gandhi Bhawan, Lucknow 226001
U.P. India**

MESSAGE



It was my cherished dream to start work on appropriate technology in an organised manner all over India. For this purpose, I had established an appropriate technology development unit in the Gandhian Institute of Studies, Varanasi, in the beginning of 1973. It is nice to see the nucleus grow into a fully developed Appropriate Technology Development Association (India) with its headquarters at Lucknow.

I was very glad to learn that the Association has now brought out a Directory of appropriate technology machines, tools, plants, equipments, processes and industries. I was always of the opinion that appropriate technology has got a great role to play in the decentralisation of power and wealth. On the one hand it simplifies the technology and makes it possible to be taken to every home and on the other it minimises the drudgery and monotony of the workers. This term has a wider application and should transcend the narrow limits of hardwares and technical equipment and become the philosophy of life for a simple living, for better management of economic and social affairs and distribution of wealth and power to the people. If we can have suitable low cost machines, plants, processes and industries which could be introduced in the villages of India in large numbers, the people will have some productive work to do in their homes. It will also contribute immensely to the wealth of the nation. This will be very close to the ideal of Mahatma Gandhi, namely, 'production by masses' as opposed to 'mass production'. Mahatma Gandhi had said "every machine that helps every individual has a place but there should be no place for machines that concentrate power in a few hands and turn the masses merely into machine minders, if indeed they do not make them unemployed".

I congratulate the members of the Appropriate Technology Development Association for their commendable efforts in collecting and collating simple technologies from all over and putting them together in the form of a Directory. I hope that the Association will also show untiring zeal and effort for introducing these equipments, processes and industries in large scale in rural areas

J. Narayan

March 23, 1977

Jayaprakash Narayan

Appropriate Technology

DIRECTORY

of

(Tools, Equipments, Machines, Plants, Processes and Industries)

VOLUME I

Issued

by

Appropriate Technology Development Association (INDIA)
Post Box 311, Gandhi Bhawan, Lucknow 226001, U. P., INDIA

ABSTRACT

Appropriate Technology—*Directory of Tools, Equipment, Machines, Plants, Processes and Industries*, first edition, 1977, 280 pages.

Simple technologies and industrial processes for small communities and rural areas with complete illustrations, designs and drawings. Divided into ten sections, comprising, (i) agro-tools, (ii) hand tools and equipment for craft, (iii) agro-processing, (iv) village and cottage industries, (v) material handling and transport, (vi) health and hygiene, (vii) education, training and culture, (viii) work power and energy, (ix) household and domestics, (x) housing and construction. Introductions have been given in each section which introduces readers to the concept and philosophy of appropriate technology in addition to giving guidance for its practice. In the end a WHO'S WHO in appropriate technology is also included which enlists individuals and groups involved in India and abroad.

First Printed, 1977, 2000 copies

Printed in India

Copies of the directory can be ordered from : M. M. Hoja, Executive Director, Appropriate Technology Development Association, Post Box 311, Gandhi Bhawan, Lucknow 226001, India. Price in India : Rs. 50 excluding postage, Price abroad: \$10 excluding postage. Discounts may be given for purchase of more than 10 copies at a time.

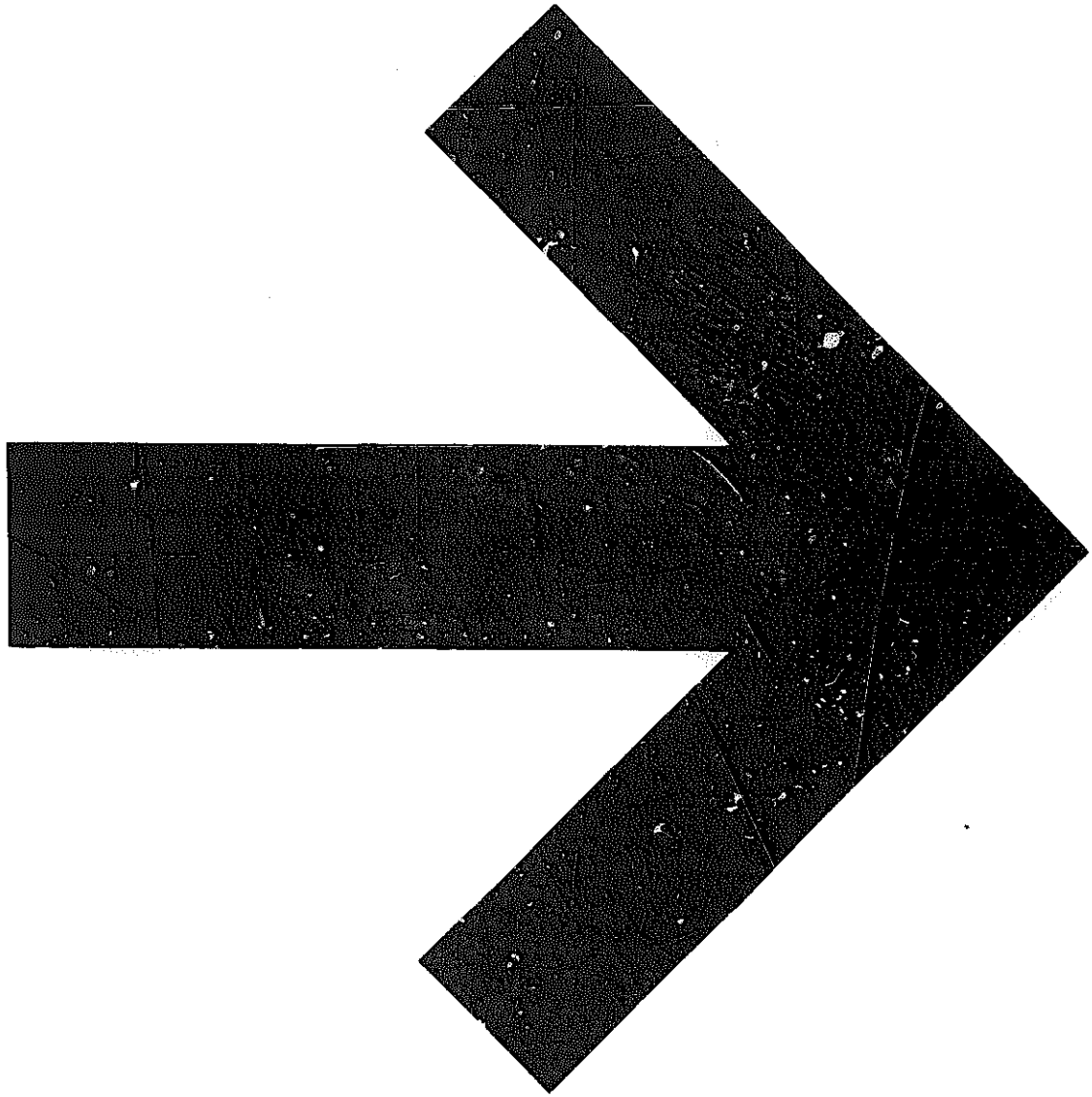

CONTENTS

DIRECTORY OF APPROPRIATE TECHNOLOGY TOOLS, EQUIPMENTS, MACHINES, PLANTS, PROCESSES AND INDUSTRIES

	<i>Pages</i>
FOREWORD	v
INTRODUCTION	ix
A. Agro Tools and Implements	1
Garden Tools (Plates I, IA, IB, IC, ID)	
i. double hoe with three prongs, ii. Leveller	
iii. Furrower, iv. Furrow opener, iv. Spade	
v. Weeding hoe.	3
Duster (Plate II)	9
Hollow earth auger (Plate III)	11
Seed and fertilizer drill (Plate IV)	13
Hand seed drill (Plate V)	15
Plant puller (Plate VI)	17
Potato digger (Plate VII)	19
Multipurpose hand operated implement (Plate VIII)	23
Fruit picker (Plate IX)	25
Seed dresser (Plate X)	27
Paddy transplanter (Plate XI)	29
Groundnut harvester (Plate XII)	31
B. Hand Tools and Equipments for Crafts	33
Hand tools for metals (Plates XIII, XIII A)	35
Hand tools for wood working (Plates XIV, XIV A)	39
Oil drum forge (Plate XV)	45
Hand operated drilling machine (Plate XVI)	49
Metal bending machine (Plate XVII)	51
C. Agro Processing	55
Paddy thresher (Plate XVIII)	57
Equipment for parboiling paddy (Plate XIX)	59
Paddy processing equipment (Plate XX)	
i. Grain purifier, ii. Rice sheller-composite unit	61
Oil ghanni (Plate XXI)	65
Mini sugar plant (Plates XXII, XXII A, XXII B, XXII C- XXII D, XXII E, XXII F)	67
Cane crusher (Plate XXIII)	81
D. Village and Cottage Industries	83
Red clay pottery (Plate XXIV)	85
De-centralised ceramic unit (Plates XXV, XXV A, XXVI)	89
Lime kiln (Plate XXVII)	97
Single spindle charkha (Plate XXVIII)	101
Matches making (Plate XXIX)	103
Surgical instruments (Plate XXX)	107
Non-ferrous metal foundry (Plate XXXI)	111
Manufacture of chalk crayons (Plates XXXII, XXXII A, XXXII B)	115

Candle making (Plate XXXIII)	121
Soap making (Plates XXXIV, XXXIVA, XXXIVB, XXXIVC, XXXIVD)	125
Bee keeping (Plates XXXV, XXXVA)	135
E. Material Handling and Transport	139
Winch used for digging well (Plate XXXVI)	141
Wheel barrow (Plates XXXVII, XXXVIII)	143
Three geared cycle rickshaw (Plate XXXIX)	147
Bullock cart (Plate XL)	149
F. Health and Hygiene	151
Sanitary latrines for villages (Plates XLI, XLIA, XLIB, XLIC, XLID)	153
PRAI type latrine (Plates XLII, XLIIA)	161
Quac stick (Plate XLIII)	165
Household filter unit (Plates XLIV, XLIVA)	167
Child weighing equipment (Plate XLV)	171
Rural health care (Plate XLVA)	173
G. Education, Training and Culture	175
Low cost microscope (Plate XLVI)	177
Solar still (Plate XLVII)	179
Soil testing kit (Plate XLVIII)	181
Better use of black boards (Plate XLIX)	183
Film strip for education (Plates L, LA)	187
Puppet making (Plates LIA, LIB)	193
H. Water, Power and Energy	199
Forms for casting well rings (Plate LII,)	201
Well lining rings (Plate LIIA)	203
Ring well installation (Plate LIII)	205
Hand pump for village (Plates LIV, LIVA)	209
Sholapur-type pumphed (Plates LIVB, LIVC, LIVD)	213
Hydraulic ram (Plates LV, LVA)	219
Hand operated suction pump (Plate LVI)	225
Bio-gas plant (Plates LVII, LVIIA, LVIIIB, LVIIIC)	227
Bio-gas plant accessories (Plate LVIIIB)	231
Bio-gas plant appliances (Plate LVIIIC)	233
I. Household—Domestics	235
Solar water heater (Plate LVIII)	237
Hand washing machine (Plates LIX, LIXA)	239
Solar cooker (Plates LX, LXA)	243
Improved chulha for kitchen (Plate LXI)	247
J. Housing and Construction	249
House design for low income group (Plates LXII, LXIIA)	251
Air seasoning of timber (Plate LXIII)	255
Grass and palmyra thatch for roofing (Plate LXIV)	259
CINVA-Ram machine (Plate LXV)	263
K. WHO'S WHO in Appropriate Technology	269

FOREWORD

The Appropriate Technology Development Association registered under the Indian Societies Registration Act, XXI of 1860, during April 1976 is a voluntary organisation, engaged in the task of popularising the techniques and methods considered useful, practical, economical, appropriate and attainable within the resources of the individuals and the communities, particularly in the underdeveloped and backward regions. The Association collaborates and coordinates its activities with the institutions and organisations engaged in similar types of activities and undertakes pilot experimentation work in cases where no suitable agencies or organisations are available for undertaking such action-oriented research projects, which are considered to be of urgent and beneficial nature and in the interest of development work, particularly for the rural communities.

A number of definitions have been advanced by the various protagonists of low-cost, intermediate, appropriate and alternative technologies and very often they are used interchangeably; but no useful purpose can be served by going into various hair-splitting niceties until we examine the appropriateness of a given technology in the context of a given situation. It is a well recognised fact that certain technologies may be found to be appropriate under a set of situations, but may be quite inappropriate in other contexts. To a person, using primitive tools in his occupation, a little improvement or modification or replacement within his resources, may result in improving his working efficiency and thus produce some surplus over his present level of earning; even such improvements can be legitimately classified under the category of 'appropriate technology' in that context, though it may be almost elementary for one who has been using more sophisticated types of tools in his profession. A large-scale modern technology in its implementation may require very heavy capital investment, introduce labour-saving devices, may need advanced managerial and marketing skills, bring concentration of wealth in the hands of those who are responsible to organise it. It may have a due place in an economy, but it brings about mass migration and uprooting of rural families, create problems of transport, communications, sanitation, housing and introduce environmental hazards, thereby bringing about an ecological imbalance in its operation. There is *mass production* and concentration of wealth in few hands, but there is no *production by masses*, as labour saving devices result in the employment of comparatively fewer hands. Such a situation is not covered under the caption of 'Appropriate Technology' as it aims at introducing efficient technology in a *decentralised fashion*, requiring comparatively low capital investment and doing the *greatest good for the greatest number of people or communities*. Thinkers who have set up the Association are quite clear in their minds as to what they aim to achieve from its various activities. They feel *decentralisation of technology* in the context of the Indian situation is the *only way* and the *most practical way* of bringing relief to the village masses who are groaning under the yoke of poverty. Appropriate technology, if suitably introduced, avoids migration of the population from the rural areas to the cities and towns and ensures more adequate distribution of wealth in the countryside. More opportunities of employment are created. It is to be clearly understood that such improvements are not to be brought about at the *cost of efficiency*. The guiding principle of low capital investment per worker and greater employment opportunities are, no doubt, kept as the focal points in its activities.

There is no doubt that the Association, though in its formative stage, has taken up surveys and studies and pilot experimentation in certain areas urgently needing the country's attention, but it has not left out a very important subject, i.e., providing the services of a 'Clearing House' in the field of appropriate technology. There is also no doubt that much is to be learnt from the local experiences and a number of individuals and organisation—government and voluntary—have gone into the process of developing appropriate technology, particularly in recent years, and in their own fields have done very commendable and useful work for their introduction in the local areas, but their knowledge has, in many cases, remained confined to certain specific areas only. What the Association, in its very early deliberation felt was that it should bring out the *first volume* of a Directory which may deal with the simple methods, techniques, gadgets, industrial technologies which have stood the test of time, so that useful and effective techniques practised in particular regions may be suitably transferred and applied in other parts of the country. All the members were requested to give all possible information in different fields of appropriate technology to the office of the Association and Mr. M. M. Hoda, the Executive Director, was assigned the responsibility to get in touch with the various organisations and individuals, obtain information from them and compile such information in accordance with a set of lines agreed to Mr. Hoda, who has considerable experience as a professional and has attended to the similar work elsewhere, has carried out this task with admirable urgency and has prepared the first draft which has been vetted and further improved upon by the Technical Committee and is now ready to be sent to the press. He deserves great appreciation of the Association for this work.

Thanks are extended to the members of the Technical Committee, particularly, to Mr. A. K. Karan, Mr. Radhakrishna, Mr. M. Akram, Mr. V. S. Mathur and Mr. Bhagwant Singh who suggested new items to be included in the Directory.

Special thanks are extended to Mr. M. K. Garg, who brought forth his valued and seasoned experiences, particularly, in the field of mini-sugar and mini-pottery and thereby extended a new emphasis for pilot experimentation which the Association is at present planning to undertake in the field of mini-spinning technology. He has contributed substantially in the preparation of this directory.

Thanks are extended to Intermediate Technology Development Group, London; Khadi and Village Industries Commission, Bombay; Council of Scientific and Industrial Research, New Delhi; National Building Organisation, New Delhi; Planning Research & Action Institute, Lucknow; Allahabad Agricultural Institute, Naiini, Allahabad; Agricultural University, Ludhiana; Gram Nirman Mandal, Shokhodeora, Bihar; VITA, UNICEF, New Delhi; Literacy House, Lucknow; Forest Research Institute, Dehradun; Andhra Pradesh Agricultural University, Hyderabad; Small Industries Development Organisation, New Delhi; Friends Rural Centre, Rasulia; Agricultural Research Tools Centre, Bardoli; Khadi Prayog Samiti, Ahmadabad, etc. etc. who were good enough to give us the benefit of their various publications and technologies developed by them and are being extended to other areas. But for their help this Directory, in its present form, could not have been brought out by the Association.

The Association is fully alive to the short-coming or Volume I of this Directory as the limitation of time and its resources have stood in its fuller and more comprehensive preparation; but it will be appreciated that it is our

maiden attempt and the second volume, the work on which has already begun, would provide still more useful and practical information so that agencies and individuals engaged in the pioneering work of popularising appropriate technology in the rural areas may be benefited and the advantages of its efforts may be extended to wider areas in the interest of the development of the country. If this Directory is able to serve the purpose even to a small extent, the Association will feel encouraged that it has made a *good beginning* and a *beginning in the right direction* to serve the masses in this important field of activity which would go a long way in ameliorating the present imbalanced growth and result in the dispersal of technology in the rural areas with a sense of urgency and speed.

December 11, 1976.

RAM DAS
Chairman

INTRODUCTION

For a balanced and healthy development of India, progress must essentially come to villages, backward areas and weaker sections of the society. Mahatma Gandhi said about half a century ago : 'India lives in villages, if villages perish India perishes too.' It was for this reason that Gandhi laid emphasis on rural development and on the improvement of technology of village crafts and industries, giving a new turn to the meaning of industries, industrialisation and machinery. He made Charkha (spinning wheel) a symbol of technology suitable for Indian conditions which can go to every Indian house.

Western technology, imported in India is not always the best, even in its limited sense of maximising production and profit and is definitely not appropriate to Indian conditions in all cases. Imported and copied from the West, it is too expensive, complicated and beyond the reach of the most of the Indian people. On the other hand, the indigenous and traditional technologies like potter's wheel, cobbler's needles and thread and weaver's loom are very inefficient and wasteful of skill and time. A systematic search and research is, therefore, needed in India to upgrade and improve the efficiency and productivity of the traditional equipment so that the fruits of technology are shared by all and the whole of the Indian working force could contribute its best in production and augmenting the national wealth and ensuring its fair distribution amongst all.

Introduction of improved tools, equipment and processes and better technology is the first priority for effective development and progress of the country. Special efforts are to be made to re-establish the decaying industry and crafts of the villages and small towns in order to create new and better job opportunities. In the competitive economy of today, economic transformation can be brought about only by giving better technologies to the peasants, craftsmen and artisans most of whom are still working under serious handicaps with primitive and inefficient types of tools and equipments. Some work has been done in this field and new techniques, tools and processes have been developed in some regions but they remain confined and do not find the media to facilitate their adoption in other regions. There is a great need therefore for the documentation of such techniques, processes, tools and equipments which have been developed and found successful, and for disseminating this information to as wide a public as possible.

It ought to be made clear that we are not advocating in reality a new technology. The real idea is to collect information on the most suitable and appropriate technology for the weaker sections and the backward areas which already exists, in order to help them to choose from these equipments. One difficulty of implementing the idea of appropriate technology is the lack of articulation of the real needs from the field level. One of the reasons for this is that until people are aware that there is a range of technological choice, problems are bound to be defined in terms of such western or widely advertised equipment and technology as are familiar and available.

The experts of appropriate technology like the late Dr. D. R. Gadgil, Dr. Schumacher and others have suggested three ways of arriving at appropriate technology solutions, namely : (1) improving the traditional and indigenous technology; (2) adopting after modification the current technology.

This includes descaling of large-scale industries; and (3) inventing new technology like solar equipment or reviving forsaken technology like wind-mill and water wheel.

This Directory is an attempt to collect information on all the three approaches. The collection is purely illustrative and does not claim to be exhaustive. Its endeavour is to illustrate appropriate technology by examples and to "bridge the gap" which keeps the Indian villages cut off from each other's experiences. There are some very good tools, equipments, techniques and processes devised in a particular region of India, but there may not be effective channels through which persons living in other parts can learn about them easily and benefit from them. It is hoped that the Directory will serve this purpose. This is meant for the use of field level workers, agents of change in the rural areas, voluntary workers and others who are fairly educated to read the drawings and the description of the equipment and processes and are able to translate them into action.

The first volume of this directory (there have to be many more volumes on a continuing basis to include all such equipments which have been invented in many places) is just an initial attempt to bring together a few samples of appropriate technology and service industries and include ideas collected from various sources. As has already been mentioned, it is just illustrative. I am quite aware of the shortcomings that many better technologies and processes evolved could not be included due to various reasons. This is our serious limitation. But it is proposed that another volume will be brought out by the Association soon with as many items as can be collected from sources inside and outside the country, which may make up the deficiency to some extent.

I am grateful to my colleagues in the Association and the staff, especially to Mr. J. A. Siddiqui for painstakingly collecting technical information, preparing initial drawings, besides doing other liaison work and to Mr. A. Bari, Office Manager, for typing the draft many times which was being corrected and modified till the time of going to the press. I am also indebted to various agencies and individuals who have been good enough to send me very useful and up-to-date information on various aspects of the appropriate technology. I am especially thankful to the Technical Committee of the Association, which has gone through the draft of this volume and made a number of suggestions and modifications, thereby improving its layout, presentation and contents. Special thanks are due to Dr. Ram Das, Chairman of the Association, who has taken much pains in going through the draft and has made immense improvement in its language and content, besides making a number of modifications and additions. His valuable guidance and advice on every occasion was a great source of strength for me.

M. M. HODA
Executive Director

Agro-Tools and Implements

INTRODUCTION

The ordinary hand tools like 'kharpa' and implements like 'Desi' plough are quite primitive, cumbersome, inefficient and expose the workers and the bullocks to fatigue and drudgery. Much experimentation has gone into the process and some handy tools and implements have been developed which are cheap, easy to handle, are more efficient in work performance, produce greater surpluses and do not expose the workers and the bullocks to such fatigue. Far more however remains to be done to improve all the tools and implements which are in vogue in different regions of the country including those of hilly and plateau tracts, yet in many areas the improved tools and implements meet the local demand. Some of the improved ones are discussed in the following chapter to bring home the point that, with little additional costs which are within the resources of the local people, the efficiency and performance could be greatly improved and the element of fatigue and drudgery reduced.

Further information on improved agricultural tools and implements can be obtained from the following :—

1. Central government's agricultural engineering workshops
2. States' departments of agriculture
3. States' agricultural universities
4. States' agricultural engineering workshops
5. Local private dealers engaged in the manufacture of hand tools, garden tools, iron ploughs, cultivators, water pumps, engines, threshers and hand operated and bullock drawn implements.
6. Local voluntary organisations and individuals engaged in research and design work pertaining to tools and agricultural implements.
7. Others

GARDEN TOOLS

(*Figures relate to Plates I, IA, IB, IC*)

Contact Agency : The Agricultural Tool Research Centre, Krishi Yantriyalaya, Bardoli, Gujarat.

The above mentioned agency has developed some useful tools and implements. They are dealt with in the following :—

1. **Double hoe with three prongs** It is a tool for digging, weeding, collecting weeds and preparing plots, etc. It is 7.5" high and 2.5" wide with 22" long wooden handle. At the other end, it has three prongs, each of 1/4" thickness (fig. 1, Plate I).

Price : Rs. 10/-

2. **Leveller :** It is used for preparing seed-beds for nurseries and for levelling beds for vegetable. It is 10" long, 1.5" high with 22" long wooden handle. (Fig. 2, Plate I).

Price: Rs. 5/-

3. **Furrower :** It makes ridges and furrows for sowing seeds and for preparing seedlings. Sowing of the vegetable seeds can be done on the ridges and watering in the furrows, for keeping soil opened. It is 4" high, 3" wide with 22" long handle. Angle of the blade with the handle is 90°. (Fig. 3, Plate IA).

Price : Rs. 10/-

4. **Furrow Opener :** It is used exclusively for opening furrows for sowing seeds. It is 1.5" wide, 4" high with 22" long handle. Angle with the handle is 70°. (Fig. 4 Plate IA).

Price: Rs. 8/-

5. Spade

(i) **Method of Construction:** 11" × 6" × 1/8" mild steel plate is cut into the shape given. 3/8" wide cutting edge should be made all round on the dotted line marked D. The shoulders are bent at right angle on dotted line C. A clamp H for fitting the handle is made of another plate 13/4" × 3/8" and rivetted on the main body of the spade with four rivets. Handle can be made from 1 1/2" to 1 3/4" round solid bamboo, 5 ft. long which is fitted in the round portion of the clamp. (Fig. 5, Plate IB).

(ii) **How operated:** The handle is held firmly with both the hands with the flat side towards the operator. The blade is pushed firmly in the ground in an upright position. Immediately after that one of the feet is put on the shoulder of the spade and pushed deeper, pulling the spade towards the operator one can work more and for longer hours with less fatigue. An excellent tool for digging irrigated land, for making furrows, for weeding and for drain making, etc.

Price: Rs. 10/-

6. Weeding Hoe

- (i) **Method of manufacture:** Blade (A) is made of carbon and steel $2\frac{1}{2}'' \times 6''$. It can be easily made from the scrap knife plate of the ginning machine. The $6''$ length portion is sharpened.

A rod (B) $1\frac{1}{2}''$ round and $9\frac{1}{2}''$ long is flattened at one end and rivetted in the middle of the blade. The other end of the rod is rivetted on the pipe (C).

Pipe (C) is made of 16 Swg. M. S. Sheet. It is made semi-circular and rivetted on to the rod, the end of which is flattened and made round of the same circumference as the pipe.

The blade makes an angle of 70° with the axis of the pipe, in which a handle made of solid bamboo 5 ft. long is inserted and nailed. (Fig. 6, Plate IC).

- (ii) **How operated:** This tool has been designed to enable a person to carry out weeding work in standing position. The blade is pushed into the ground and pulled towards the operator.

Price: Rs. 10/-

PLATE I

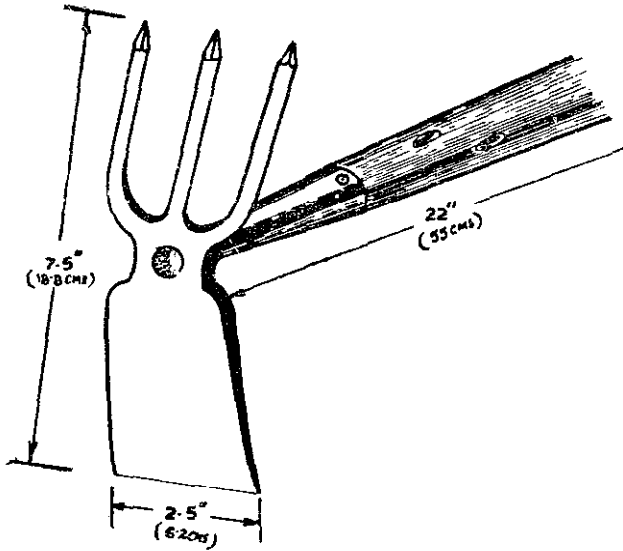

FIG. 1. DOUBLE HOE WITH THREE PRONGS.

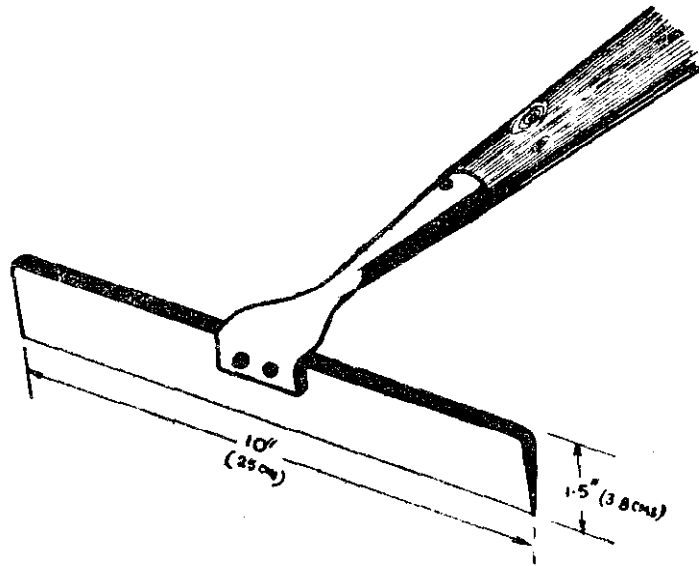

FIG. 2. LEVELLER

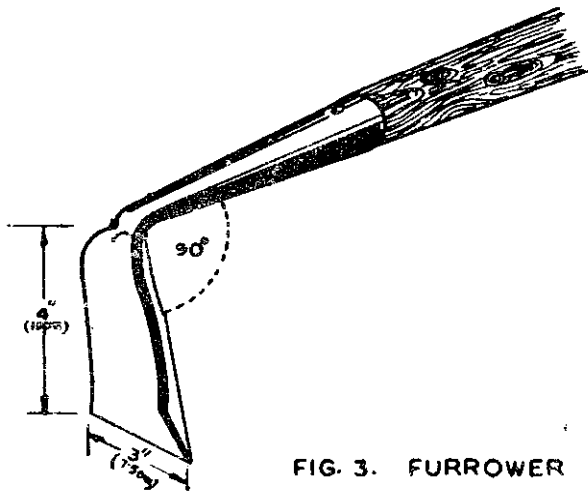

FIG. 3. FURROWER

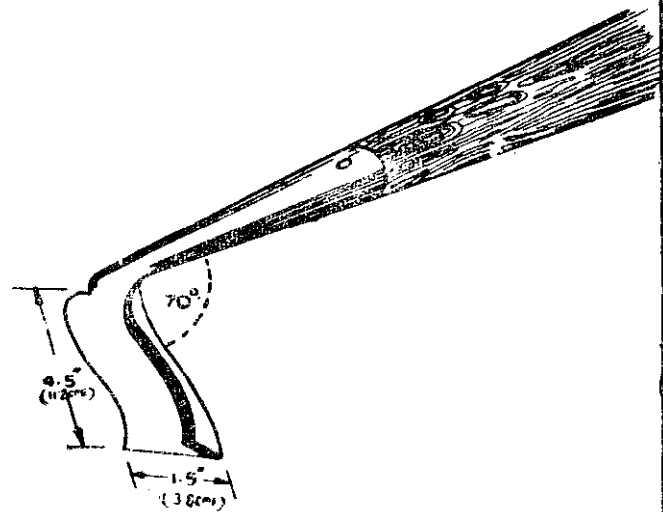

FIG. 4. FURROW OPENER

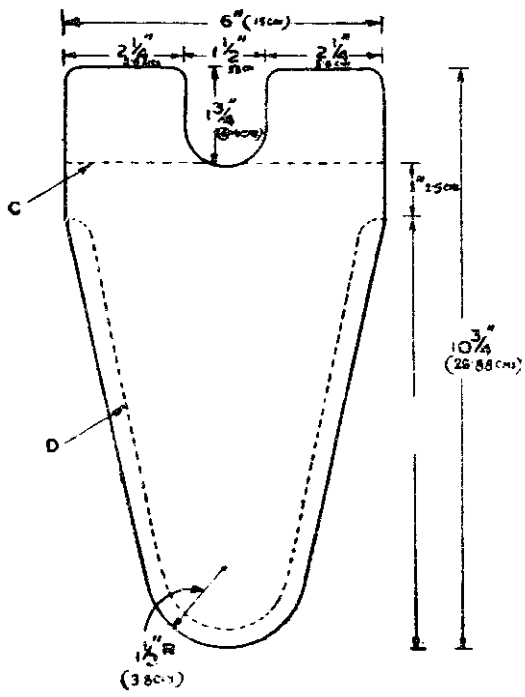

FIG. 1

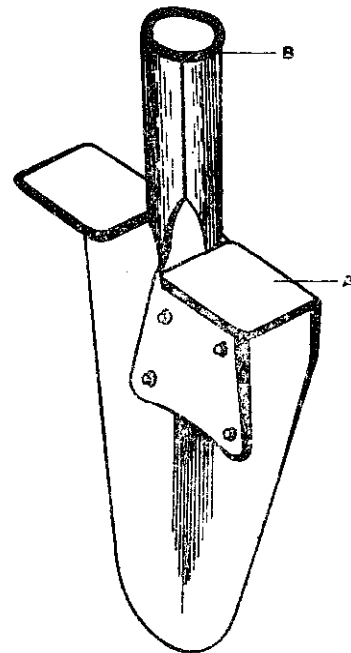
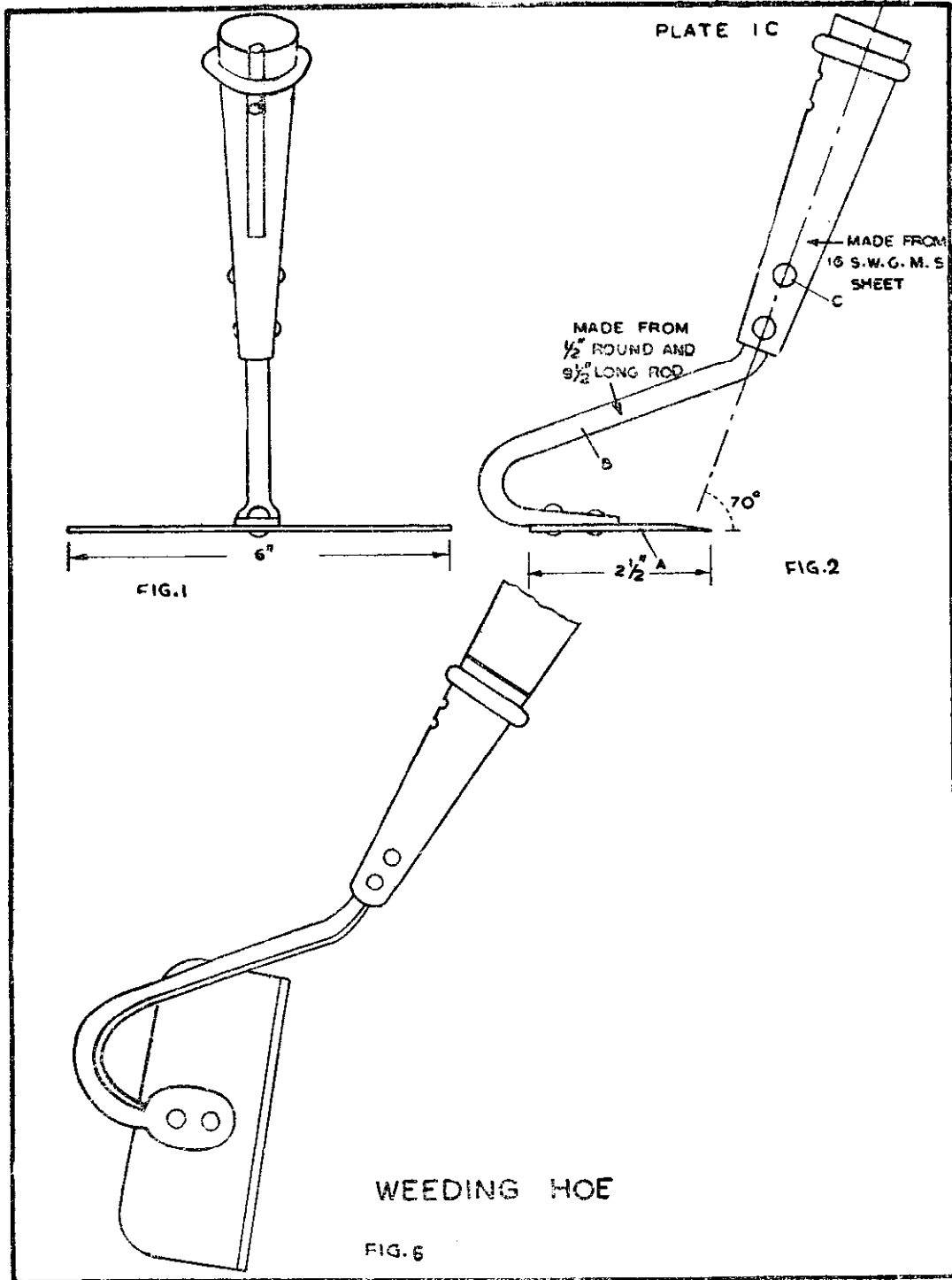

FIG. 2

Fig. 5 SPADE



DUSTER

(*Figures relate to Plate II*)

Contact Agency: Agricultural Tool Research Centre, Bardoli, Gujarat.

Introduction: This duster of a simple design is useful equipment for spraying insecticide and pesticide in small backyard kitchen gardens. This can be easily fabricated by village blacksmiths and carpenters.

Construction: The powder container is 6" long and 4 1/2" dia. made of 26 swg. galvanised iron sheet (Fig. 1). Cone B is fixed to the container 1" from the top. Two tubes D₁ and D₂ both 13" long and 1" dia. are fixed to the cone, and are made of 28 to 30 swg. sheet. They are made in two parts to facilitate handling and transport. Face E is made of a 5" sheet and is folded from three sides and rivetted. The outside portion is 4 1/2" to 5" long. The face is bent a little inwards, so that the powder may hit the face and spread like dust. A valve is fitted underneath the bellows, which opens up when the air goes to the container and closes when the bellows draws the air in. When the bellows is operated, the air goes inside the container A, through the valve and the air pressure forces the powder out.

The bellows is made from two oval shaped wooden pieces of 9" × 4" × 3 1/4" size. (Fig. 3 and 4). Both the ends are made circular of radius 3" and 2" respectively. Both the wooden pieces are joined by an oil cloth J. The oil cloth is fixed in such a way that the bellows on one side opens 10" wide and on the other side it is fixed to the pieces by means of leather strap and nails. The oil cloth and the leather strap should be fixed in such a way that it is air tight. On the upper side, a handle K is fitted to operate the bellows. On the lower portion a semi-hemispherical bowl is fitted with three screws. The air comes in through the hole in H inside which the valve is fitted. When the bellows is opened, the air comes in through three holes provided in the wooden piece, the valve of which closes when the bellows is pressed. (Fully assembled duster is shown in Fig. 2)

How to operate :

On the top of the powder container A, bellows J is fitted. The bellows is joined to the container by latch G. The latch is opened and the bellows is taken out before filling the container with powder. The powder is filled up to a level below tube C. The powder comes out through the cone B and tube C. A rope or strap is fitted in F and the duster is hung by the shoulder. One hand is kept on the bellows and by the other hand pipe D is held. The powder can be sprinkled in any direction. When the bellows is pressed, the air pressure forces the powder in the container to pass through tubes C, D₁, D₂ and to come out through the face E and spread in the field with the air.

Price: Rs. 20/-.

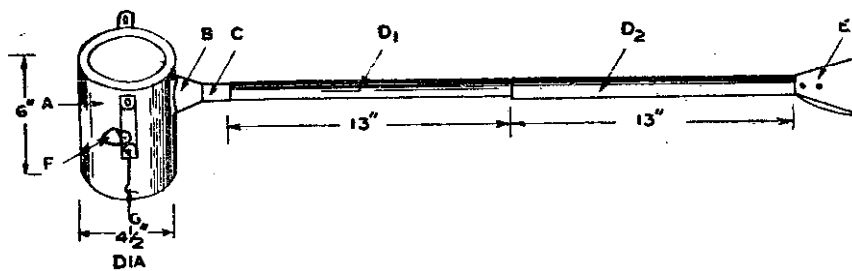

FIG. 1

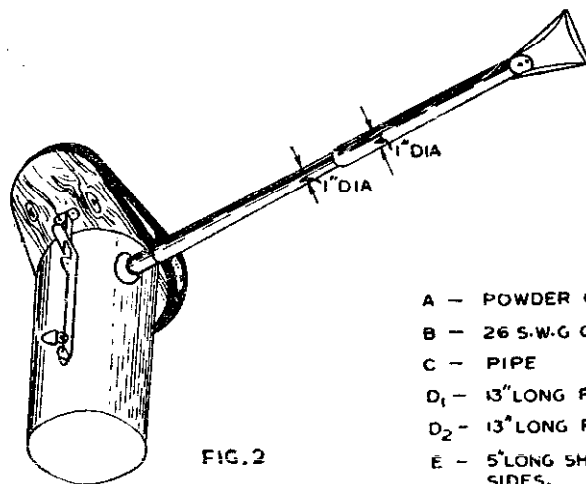

FIG. 2

- A - POWDER CONTAINER
- B - 26 S.W.G GALVANISED SHEET CONE
- C - PIPE
- D₁ - 13" LONG PIPE
- D₂ - 13" LONG PIPE
- E - 5" LONG SHEET FOLDED FROM THREE SIDES.
- F, G - LATCH
- H - HOLE
- I - VALVE
- J - OIL CLOTH
- K - HANDLE

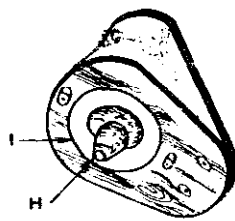

FIG. 3

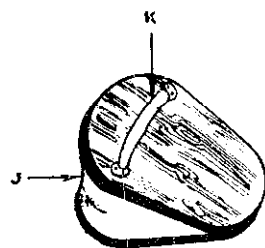

FIG. 4

DUSTER

HOLLOW EARTH AUGER

(*Figures relate to Plate III*)

Contact Agency: Agricultural Tool Research Centre, Bardoli, Gujarat.

Introduction: This implement is used for digging holes in the field, either for fixing poles for fencing or for localised cultivation to save fertilizer and irrigation water. The whole field need not be ploughed and manured:

Method of Construction:

- (a) **Semi circular blades and container—2**
Two plates $11'' \times 6'' \times 1/8''$ are cut in shape as in figure K. Edges G and H are sharpened up to $3/8''$ from the back side and formed into blades. Both the plates are rounded up in semi-circular form of about 6" dia. At the dotted line in (Figure 2), the edge G is turned at an angle of 45° . Edge H should also be turned inwards near the tip. Both the semi-circular containers should now be placed face to face and any defect rectified. The cutting edges of the auger should be like the cutting edges of a drill, i. e., the cutting edge should be in the front.
- (b) **Fixing strip:** $1\ 1/2'' \times 1/2''$ flat bar is bent in the form as shown in (Fig. 3). There should be three holes on both sides to take $1/4''$ screw. The holes should be counter-sunk. In the upper side of the strip a flange C containing the handle is bolted.
- (c) **Handle:** Handle is made out of $3/4''$ dia. pipe which is $2\ 1/2$ ft. long. The upper end is threaded on to a T. On both sides of the T 9" long pipes are threaded on, which facilitate rotating of the auger. (A fully completed auger is shown in Fig. 1)

How operated: When a shallow, not too deep, hole is to be dug, the hollow earth auger can be used. The auger is to be kept upright on the place where hole is to be dug. The handle F is then rotated clockwise. The two blades at the bottom cut the earth and take up the dug-up soil in the two semi-circular containers A. As the hole goes deeper, the blades cut the hole and make it of a fixed diameter. If the upper crust is too hard, the upper portion may be loosened by means of a spade before using the auger. When the container is full of excavated soil, the auger may be taken out and the soil emptied. The empty auger should again be placed in position to make the hole deeper.

The auger can also be used in barren land for digging 2 to 3 ft. deep hole and for planting saplings. This saves one from the trouble of preparing the whole barren land. It can also be used for digging holes for fixing poles and pillars.

Price: Rs. 35

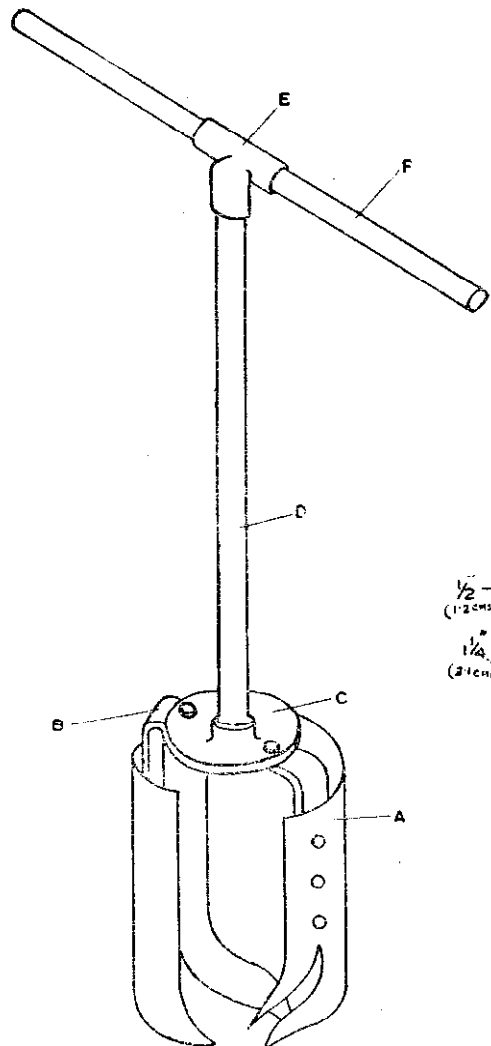

FIG. 1

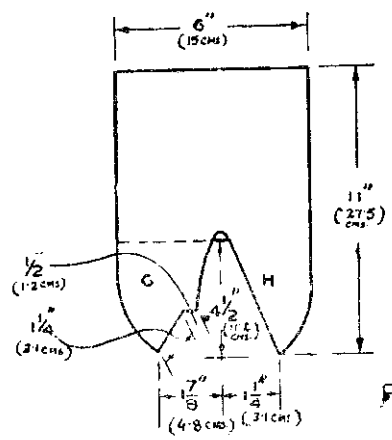

FIG. 2

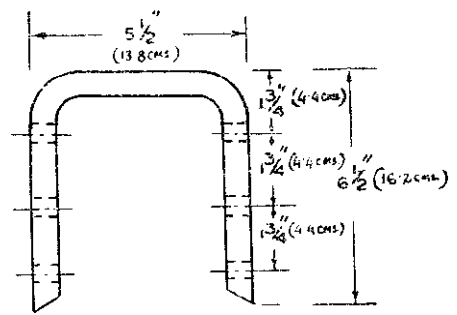

FIG. 3

HOLLOW EARTH AUGER

SEED CUM FERTILIZER DRILL

(*Figures relate to Plate IV*)

Contact Agency: Allahabad Agricultural Institute, Naini, Allahabad.

Introduction: The need for a seed and fertilizer drill particularly to sow high yielding varieties of wheat in addition to sowing other crops is greatly felt these days. High yielding varieties of wheat are recommended to have row to row distance of 4 1/2" or 5 1/2". In addition to that, seeding with fertilizer is also necessary to save two operations and also to save wastage of fertilizer.

Construction: The seed-cum-fertilizer has the following parts and is fabricated as follows:

- (i) **Furrow openers:** There are six furrow openers of the same shape and size. The distance between the openers are adjustable and they are removable. The number can be reduced to suit the soil conditions and draftability of different types of bullocks.
- (ii) **Seed Box:** The seed box is partitioned with a removable plank and one half is fitted with six metering devices for the seed and the other half with six metering devices for the fertilizers. The seed and fertilizer metering devices have small lids in the box to cover or shut off any number of seed metering and fertilizer metering units. (Fig. 1 and 2 show the front and rear view of the drill)

How to operate: The lids of the seed metering devices are closed and the box filled with fertilizer. All the tubes from the fertilizer metering units are attached to the furrow-openers. The fertilizer is applied at whatever depth and in whatever quantity it may be required.

To carry out the planting operation, all the fertilizer from the box is removed and the lid of the fertilizer metering device is closed. The box is filled with seed to be sown. All the tubes from seed metering units to the furrow openers are attached. The furrow-openers are adjusted at the desired row to row distance.

The advantage of the system is that the width of the seed drill covered is doubled in comparison with other designs, which have only 3 furrow-openers for seed and 3 furrow-openers for fertilizer.

For drilling crops such as paddy, the box should be partitioned and 3 furrow-openers be used for dropping fertilizers and 3 for sowing paddy, as in the case of paddy the usual row distance is about 9". Furrow openers for fertilizer may be adjusted to drop fertilizer at whatever distance and depth from the seed is recommended.

For sowing sorgham or maize the row to row distance may be 18"-21" or even more, and the same practice may be adopted as in the case of paddy, except for closing the lids of the middle fertilizer metering as well as the seed metering unit.

Precaution: While using the seed-cum-fertilizer drill, check should be exercised to see once in a while if the seed is dropping regularly and at the right depth.

Price : Rs. 200/- approx.

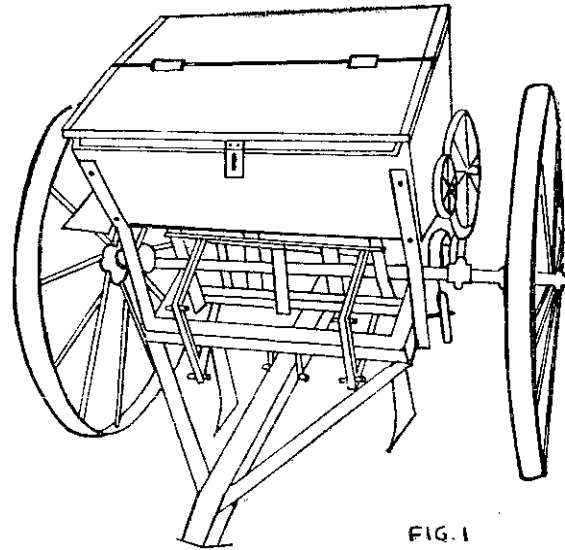

FIG. 1

FRONT VIEW

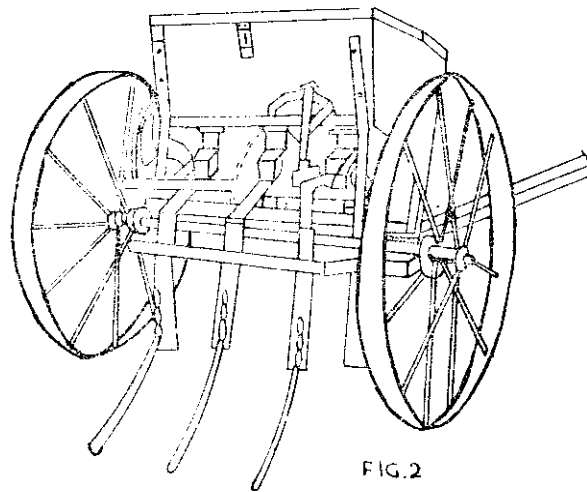

FIG. 2

REAR VIEW

SEED AND FERTILIZER DRILL

HAND SEED DRILL

(*Figures relate to Plate V*)

Contact Agency: Agricultural Tool Research Centre, Bardoli, Gujarat.

Introduction: A simple one row seed drill is shown in Plate V, which can be easily manufactured by a village blacksmith.

Method of manufacture:

It essentially consists of the following parts:

- (a) Funnel A (Fig. 1)
- (b) Pipe B (Fig. 3)
- (c) Furrow opener C (Fig. 4)
- (d) Pole O (Fig. 5)
- (e) Rope E (Fig. 2)
- (f) Shoulder strap F (Fig. 6)
- (g) Clips and rings (Fig. 7)

Funnel and pipe can be made from an old pump used to take out kerosene oil from tin. At one end of the pipe, furrow opener C is inserted, at the other end on the top a ring with a hook is fixed which takes the rope E, which is tied at the other end to the pole and the shoulder strap. Pole D is fixed to the pipe by means of an iron clamp.

How operated:

The implement is worked by two persons. One man pulls the implement putting a cross belt F on his shoulder and holding pole D. Another man holds the pipe and pours seed or fertilizer through the funnel. The seed or fertilizer passes through pipe B and is implanted through the furrow opener C.

Price: Rs. 25/-

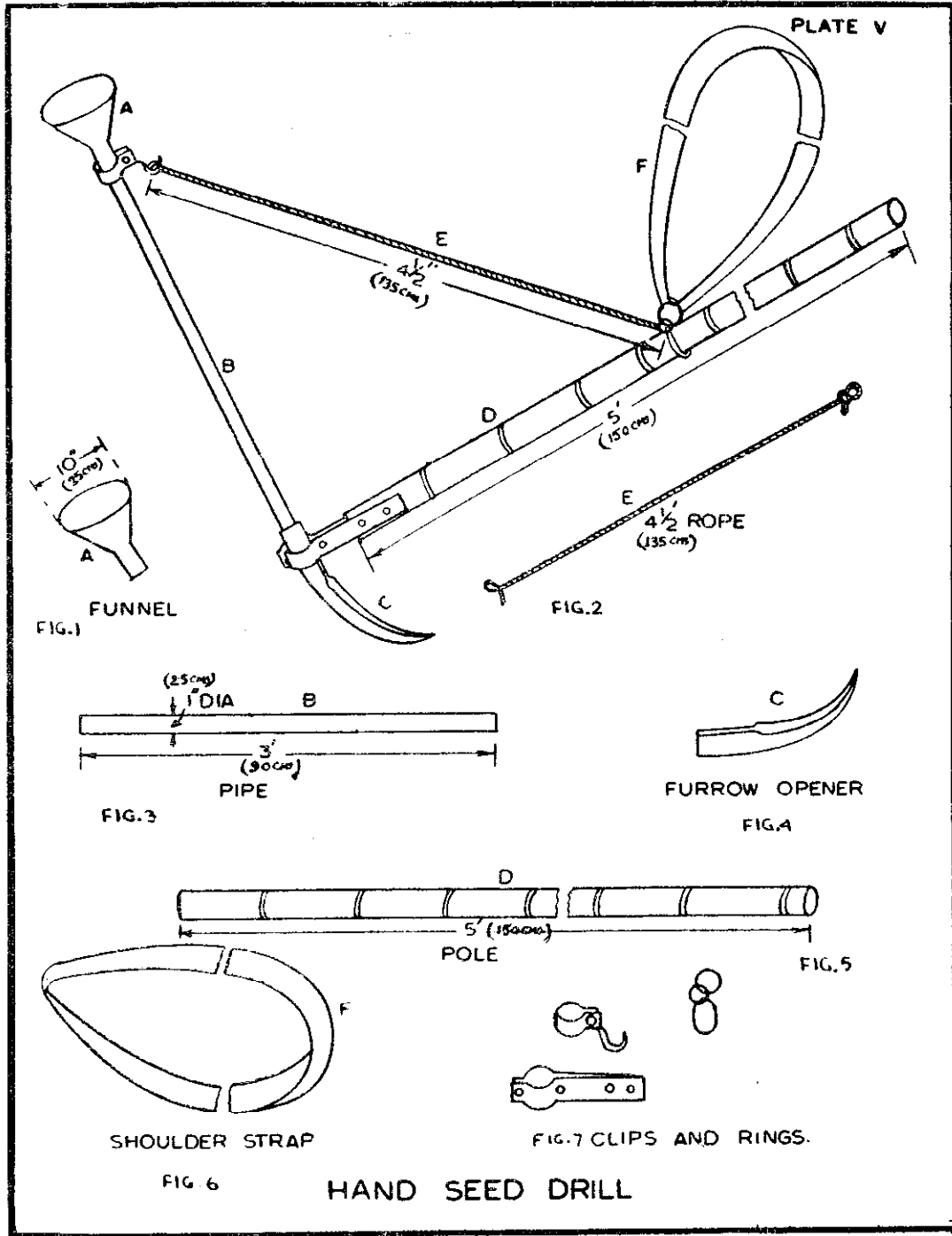

PLANT PULLER

(*Figures relate to Plate VI*)

Contact Agency: Agricultural Tool Research Centre, Bardoli, Gujarat.

Introduction: It is a very simple and ingenious device to pull out roots of the plants like arhars sugarcane, kapas, etc. It can be very easily made from scrap materials by the village black smiths.

Method of Construction:

The arm AB is made of $1\frac{1}{2}'' \times 1\frac{1}{2}''$ mild steel flat. It is best made from the tyre, which is used for the wheels of tonga and carts. It is available in 12 ft. length, of which three arms can be made.

Jaw GE is made in semi-circular form out of $1\frac{1}{2}'' \times 1\frac{1}{2}''$ mild steel and 19" long. The end G is made in the form of a jaw and end E is used as a fulcrum. (Fig. 4).

Another M. S. Flat $1\frac{1}{2}'' \times 1\frac{1}{2}'' \times 10''$ is bent in the form of jaw F to couple with jaw G. Both the jaws are bolted with $\frac{1}{2}''$ dia. and 2" long bolt. (Fig. 5 and 6).

The upper end of arm F is rivitted to the arm at C by $\frac{5}{16}''$ dia. rivet. Another strip H (Fig. 3) is rivitted to the lower rivets and rests on the head of bolt D, to hold it in position, so that it may not get loosened. (*Completed Plant Puller is shown in Fig. 2*)

How operated:

The plant stem near the root is tightly held between jaws F and G. With E acting as fulcrum, the person operating, pulls arm A towards himself. (Fig. 1). Cotton and arhar plant stem can be thus easily pulled out, facilitating the ploughing of the field afterwards. Two acres of land can be easily managed in one day by one person.

Price: Rs. 25/-

PLATE VI

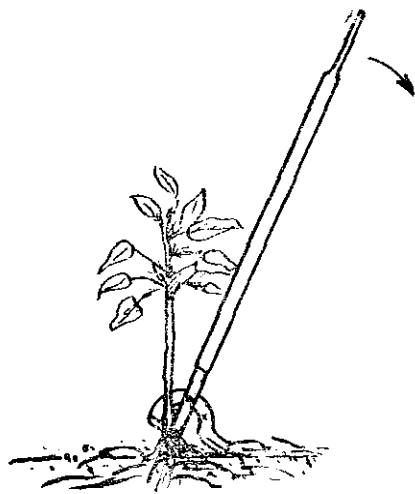

FIG. 1

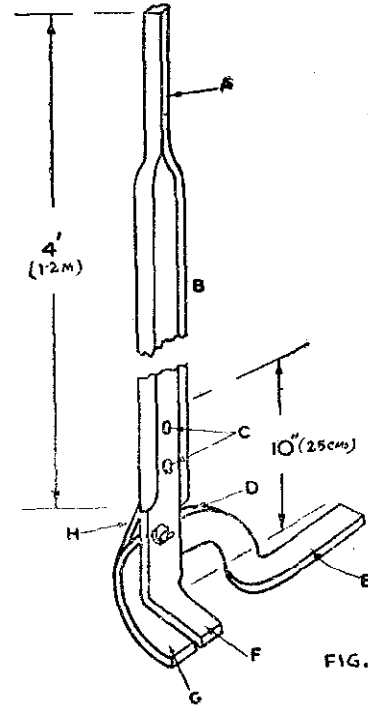

FIG. 2

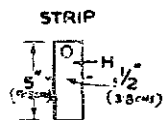

FIG. 3

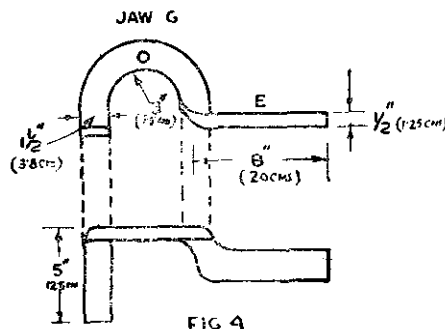

FIG. 4

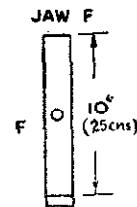

FIG. 5

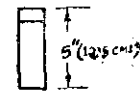

FIG. 6

PLANT PULLER

ANIMAL DRAWN POTATO DIGGER

(*Figures relate to Plate VII*)

Contact Agency: Allahabad Agricultural Institute, Naini, Allahabad, U.P.

Introduction: There was a great need for designing a mechanical potato digger, drawn by bullocks to overcome the time-consuming and monotonous process of harvesting potatoes and other root crops like shakarqand (sweet potatoes) etc., which involve hard manual labour with tools like spades, hoes, etc. The potato digger of this design helps in reducing labour costs, ensures quicker operation, and increases the margin of profit for the growers.

The principle on which the potato digger has been designed is to shear the soil in the horizontal plane below the depth to which potato tubers are formed to lift the soil along with the tuber on a grading frame through which the tubers would be separated from the soil and left at the rear side of the digger. The design ensures simple construction, minimum damage to the tubers, clog-free operation, placement of the tubers on the surface of the soil and desirable draft.

Method of construction: The digger consists of four basic parts, viz. (i) share (Fig. 2), (ii) grading frame or platform (Fig. 1), (iii) goose neck short settle beam (Fig. 1), (iv) shaker wheel, with legs under the grading platform. (Fig. 3).

- (i) *The share* is 43 cm. wide and 38 cm. long, oval in shape for digging and uprooting the tubers.
- (ii) *The grading frame or platform* consists of M. S. rod of 1.9 cm. size welded to a bar adjacent to the share and has sheet metal guards on both sides to guide the material passing over to the sides. It is a hinged frame and goes up and down due to the falling action of the shaker wheel.
- (iii) *The shaker wheel* is a 26 cm. dia. and 6 cm. wide wheel having 5 curved legs of 9 cm. each, situated under the middle of the grading frame. The whole grading frame drops by 9 cm. imparting force to the soil having tubers. Due to the rapid falling action of the grading frame the tubers are separated from the soil.
- (iv) *Accessories* consist of the beam, which is goose neck type, gauge wheel and small shovel. The goose neck beam is made of M.S. flat of 7.5 cm. \times 1.5 cm and about 130 cm. The share is fixed on the lower end of the beam and the upper end has a nautical hitch for depth control. With the beam, there are two wooden handles for operating and balancing the diggers. Also, there are two gauge wheels attached to the beam. The depth of the gauge wheel and their distances from each other are adjustable. One of them moves over the ridge and the other in the furrow which provides balance and assists in depth control. A small shovel-like structure is also fixed right in front of the share to dig and loosen the crown of the ridge with the weeds and potato plants to avoid hinderance to the soil with creepers and weeds sticking to and around the beam.

How to operate: A pair of bullocks and two persons are required to operate the potato digger. The necessary adjustments to gauge wheel and vertical hitch are done, according to the requirements. The digger digs the complete ridge upto the depth of the tuber formation. The oval shaped share cuts and lifts up the soil along with the tubers on the grading frame which has a jerking action due to the rolling wheels (shaker) having legs about 9 cm. long. Due to the jerks given by the falling grading frame, the tubers are separated from the soil lumps and fall behind. Later the potatoes are picked up in baskets.

<i>Performance:</i>	Depth of the cut	...	15-20 cm.
	Width of the cut	..	50 cm.
	Total draft	...	140-200 kg.
	Price	...	Rs. 200.00 approx.

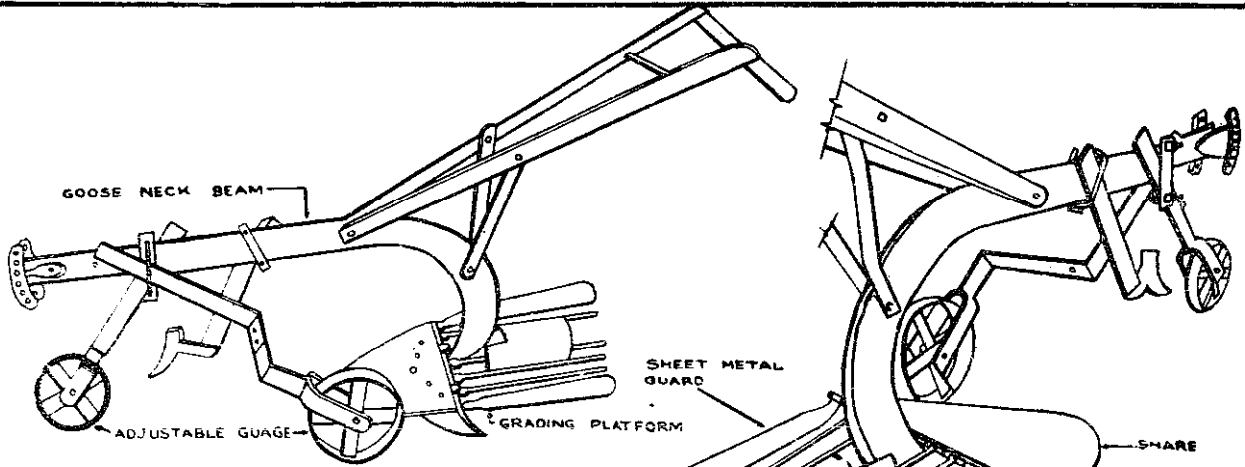

FIG. 1

FIG. 2

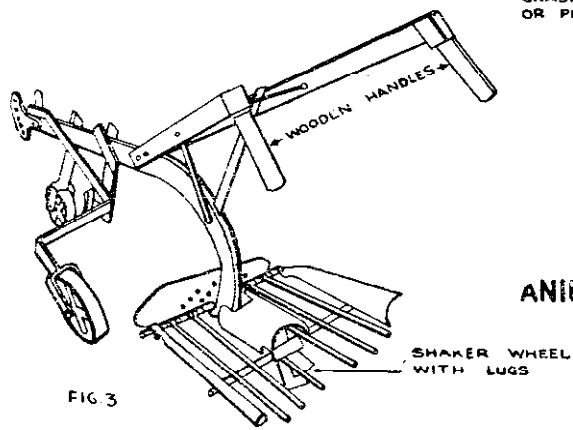
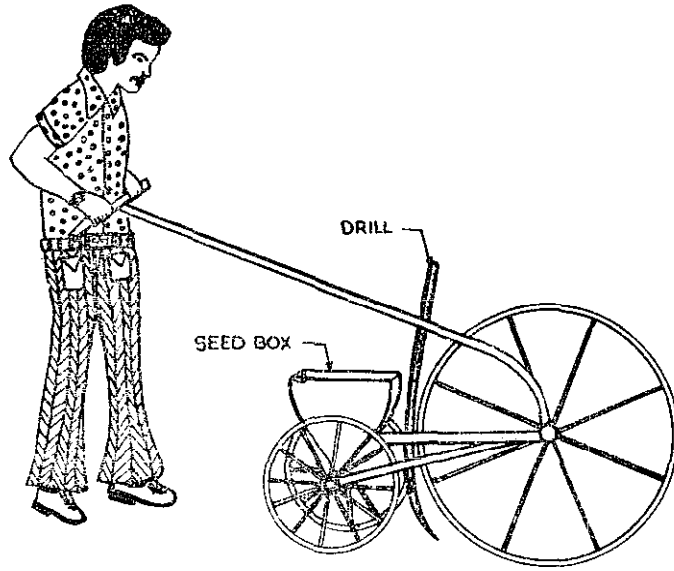

FIG. 3

ANIMAL DRAWN POTATO DIGGER

PLATE VII

PLATE VIII



SEED BOX

DRILL

FIG. 1

MULTI PURPOSE HAND OPERATED
IMPLEMENT WITH SEED-DRILL ATTACHMENT.

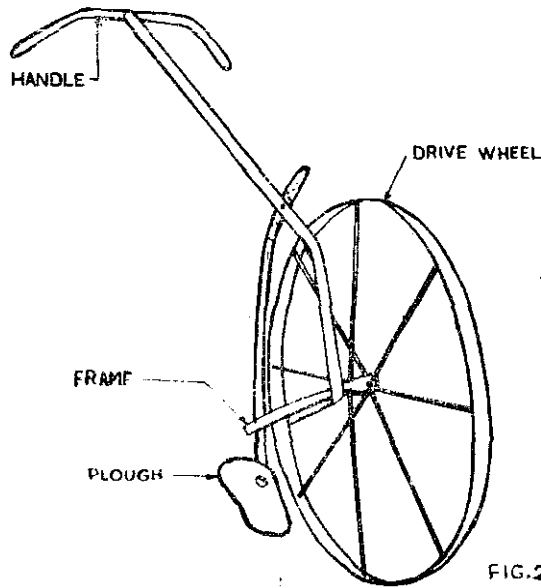

HANDLE

DRIVE WHEEL

FRAME

PLOUGH

WITH PLOUGH ATTACHMENT

MULTIPURPOSE HAND
OPERATED IMPLEMENT

FIG. 2

A MULTIPURPOSE HAND OPERATED IMPLEMENT

(*Figures relate to Plate VIII*)

Contact Agency : Allahabad Agricultural Institute, Naini, Allahabad.

Introduction: Sometimes an implement capable of being operated by one person, is badly needed, to work on kitchen gardens, small fields and vegetable gardens. Such a multi-purpose hand operated implement is described below, to which various equipments like plough, sweep or drill can be attached.

Description: This implement can be constructed very easily according to the drawings given. It consists of a wheel and a handle. Any type of attachment like plough or harrow or seed drill equipment could be attached to this implement. Five different types of attachments have been fitted to meet the various requirements, namely (1) plough, (2) cultivator (rake type), (3) cultivator (sweep type), (4) sweep (harrow type), (5) seed drill. The plough attachment can plough and harrow 6 cm. deep and 60 cm. wide. Cultivator rake collects grass from the ploughed land and breaks clods satisfactorily. The cultivator (sweep type) has three sweeps and covers 20.5 cm. width. The basic purpose of this cultivator is to break the top crust of land and pulverise it to a depth of about 6 cm. It also cuts grasses in the field. The sweep with its shape like arrow head penetrates into the soil and loosens it very easily and can be used for inter-culture.

Fig. 1 shows the implement attached with seed drill, while Fig. 2 shows it attached with the plough.

The seed drill can plant wheat, gram, peas, bajra and mustard satisfactorily.

This multipurpose hand operated farm implement can play a vital role in different operations as a primary and secondary tillage implement in the hilly tracks as well as home gardens.

Price : Rs. 100 Approx.

LOCAL FRUIT PICKER

(Figures relate to Plate IX)

Introduction: Sometimes it becomes very difficult to pluck fruits from trees like mangoes, apples, etc. Even if a person gets on the top of the tree, some of the branches are very fragile and thin which might give way under the weight. It is, therefore, necessary that some type of contrivance is used so that fruits can be plucked from any branch standing on the ground. Fruit picker described below is one of such contrivances which can be very easily made anywhere.

Construction: Take a bamboo part of three knots. Cut out its upper and lower knots. Then from the top, the bamboo is sliced into 6 to 8 slices as shown in Fig. 3. Wooden pieces are then hammered inside the sliced portion so that it becomes tapering. These can easily hold medium size fruits like apples or mangoes inside the cavity formed. An extension stick or bamboo is then attached to the bamboo pieces and can be made long enough to reach any branch of a tall tree. Fig. 5 shows how mango is plucked by means of fruit picker one at a time and then placed on the ground without damaging the fruit.

Price: The cost is not more than Rs. 2. A bamboo pole costs about Rs. 2, but in a village it can be had free of cost.

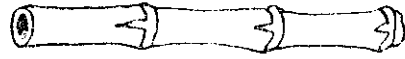

FIG.1

TAKE A BAMBOO PART OF THREE KNOTS

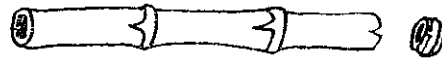

FIG.2

CUT ITS UPPER KNOT

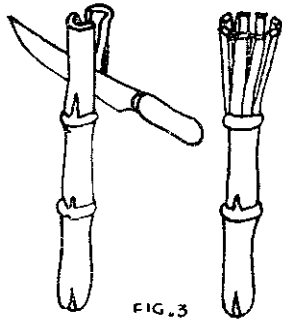
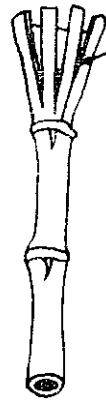

FIG.3

CUT IT INTO 6 TO 8 SLICES
BY KNIFE AS SHOWN IN FIG.



WOODEN PIECES

FIG.4

NOW FRUIT PICKER IS READY
USE IT BY ATTACHING
A LONG BAMBOO



FIG.5

A MAN IS PLUCKING MANGO BY
USING A FRUIT PICKER

FRUIT PICKER

SEED DRESSER

(Figures relate to Plate X)

Introduction: It is an ingenious device to mix a few ingredients or to tumble materials manually by hand.

Construction: A drum of 35 cm. dia. and 46 cm. length (other sizes can also be chosen according to the necessity and convenience) is mounted on a horizontal spindle in such a way that the larger diagonal of the drum coincides with the spindle. The spindle itself is mounted horizontally on two bearings with a handle attached to it on one end. The bearings are mounted on two stands on two sides. At one end of the drum, a small door is provided which can be closed tightly. Front and side elevation of the dresser is shown in the figure.

How to operate: The materials to be mixed like seed and fertilizer or the materials to be tumbled with saw dust or other polishing materials are placed inside the drum in which two fins are provided all along the length. After the door has been closed tightly, the handle is rotated rapidly. Due to the eccentric placement of the drum the upper portion comes down and the lower portion goes up at the time of each revolution and thus jolts the materials very rapidly inside the drum mixing them with each other very quickly. The materials can also be inspected after opening the door and when they are found to be thoroughly mixed or polished, as the case may be, they can be taken out through the same door.

Price: The cost of fabricating such a machine in the village will be about Rs. 25.

SEED DRESSER

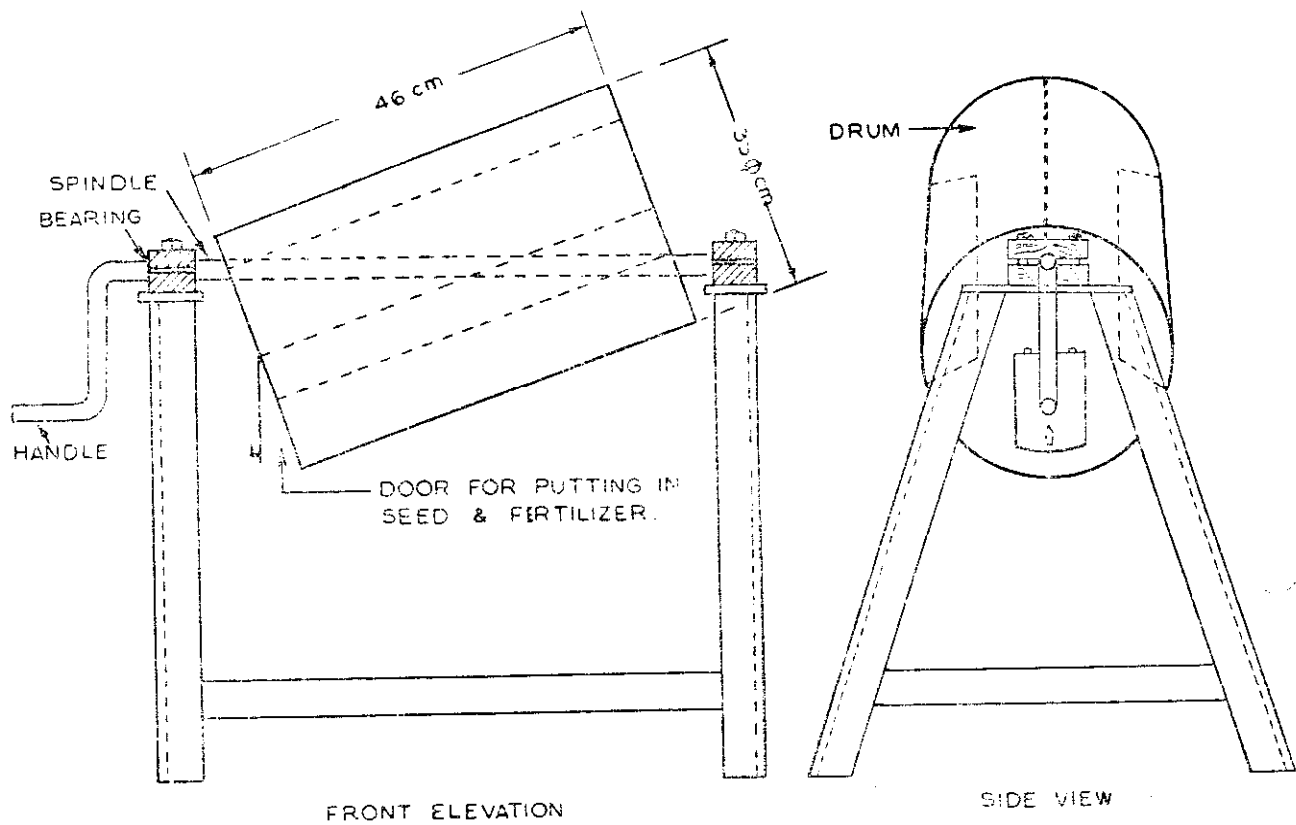

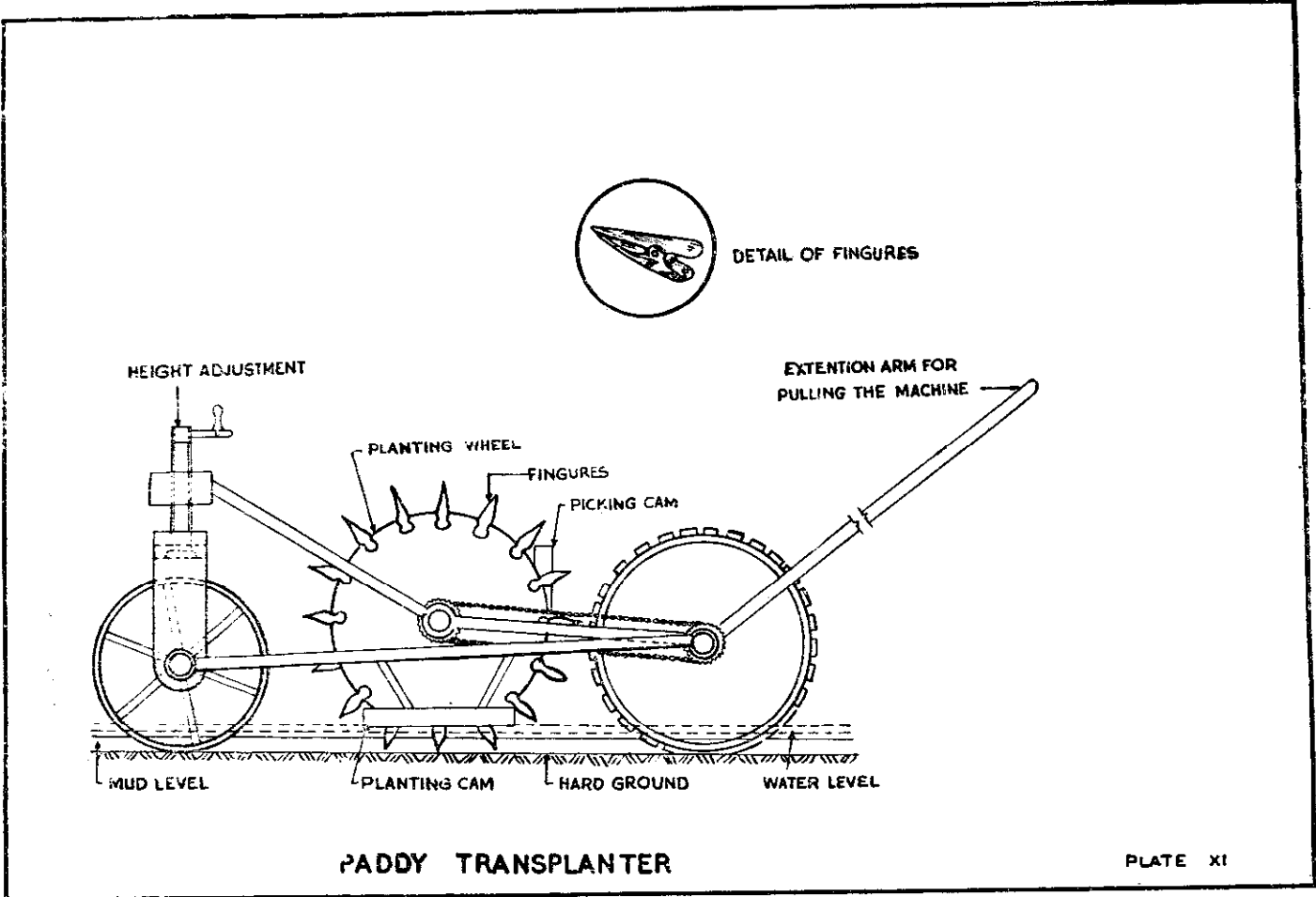

ANIMAL DRAWN GROUND NUT HARVESTER PICKER

(Figures relate to Plate XII)

Contact Agency: Andhra Pradesh Agricultural University, Rajendranagar, Hyderabad.

Introduction : Groundnut is an important commercial crop in our country. The conventional method of harvesting groundnut is to pull the plant manually. This consumes a lot of labour and time and subjects workers to drudgery and monotony. The animal drawn groundnut harvester is, therefore, an appropriate equipment to be used in this country for harvesting groundnut.

Construction: The implement consists of a frame, two ground wheels, a harvesting plate with lifting and lowering mechanism, a picker roller, a tray, a tail wheel, a driving mechanism and a hitch. Full working drawings of the implement have not been provided here but an idea of its construction and working can be had from the attached diagrams. (Plate XII). The persons interested should approach the Agricultural University to get full working drawings for manufacture. The implement consists of a frame, two ground wheels, a cutting blade with lifting and lowering mechanism, a picker roller and a tray. It is operated by a pair of animals and two persons. The implement could harvest about 0.6 hectares of groundnut during an eight-hour day.

Price: Rs. 500/-Approx.

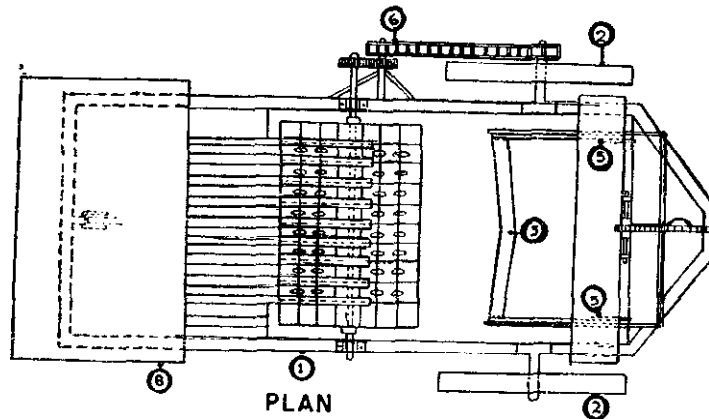

PLAN

- ① FRAME ② GROUND WHEEL ③ HARVESTING BLADE ④ LIFTING AND LOWERING MECHANISM ⑤ DISC COUNTERS ⑥ DRIVE MECHANISM ⑦ PICKER ROLLER ⑧ TRAY ⑨ TAIL WHEEL ⑩ VERTICAL ⑪ SEAT

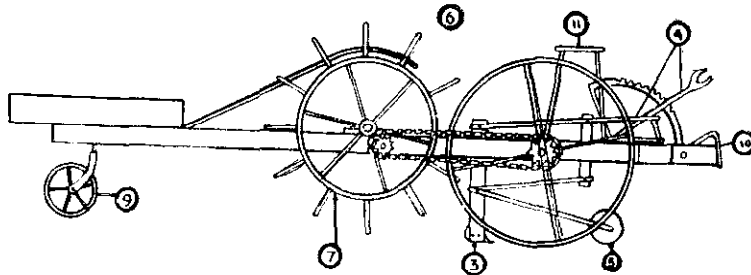

ELEVATION

ANIMAL DRAWN GROUNDNUT HARVESTER-PICKER

Hand Tools and Equipment

For

Crafts

INTRODUCTION

A variety of crafts and industries exist in the villages of India from times immemorial. The skill of the workers and the artisans converts materials available for little or no cost into articles of great value. They are sold in large numbers in the country as well as outside. The products are made by using hand tools like hammers, chisels, carpenter's tools, blacksmith's forges, foundries and such other equipments. These tools and equipments are not worked by means of mechanised power or external energy sources. They are based on the simple principles of levers, inclined planes, screws, etc., which help the workers to convert the raw materials into products of great utility and beauty. Very little, however, has been done to improve these tools without in any way sacrificing their simplicity. The artisans and workers have been working for centuries with the same set of tools and equipments. Sometimes in the urban industries, some improved tools and equipments are used but few attempts are made to introduce them into the rural areas. Thus, on one hand, there is a need for the scientists and technologists to work on the improvement of hand tools and equipments for crafts and industries, and, on the other, to introduce them into the villages.

Some of the tools and equipments have been described in this section to highlight the need for the adaptation and adoption of these tools in the rural areas and for further improvement of the hand tools of other crafts and industries.

HAND TOOLS FOR METAL WORKING

(Figures refer to Plates XIII and XIII A)

Introduction: Hand tools are aids to the workers and can be considered as extension of their limbs to enable them to perform work of a nature which ordinary limbs like hand, foot, teeth, nails, cannot do. They improve their strength for lifting, rotating, cutting and other properties, by using the principles of lever, screws, pulley-blocks, etc. A right selection of hand tools, and their right use will greatly increase the workers' efficiency and productivity. Some of the common hand tools for metal working are described in the following paragraphs. They are available from all recognized dealers and are a great improvement over the traditional ones which are not so efficient as the improved ones.

Vice: The common tool for holding job for carrying out operations on them is the Engineers Parallel Jaw Bench Vice. (Fig. 1). The body and the sliding jaw are made of cast iron. The faces are made of tool steel with teeth cut on them and screwed to the jaws. The other parts are made of steel.

The job has to be set in the centre of the jaws and the handle revolved until the job is gripped tightly between the jaws. The operations of chipping, filing, bending, tapping, punching, etc. are then carried out on the job. Vice facilitates the working, and keeps both the hands of the operator free.

Hammer: A ball-pane hammer is the most commonly used hammer, which forms an indispensable part of a worker's tool kit. (Fig. 3). It is used for striking blows on the tool or the job, for chipping, bending, punching or any other work. Skillful handling results from trained coordination of hand and eye. In giving a proper swing, the arm pivots at the shoulder, elbow and wrist.

Chisel: Cold flat chisel from 3/4" to 1" wide at the cutting edge is used for chipping, reducing the thickness of the metal or for cutting. (Fig. 3a). It helps the worker to do a variety of work. They are forged out of hexagonal or octagonal steel bar, about 8" long, the last 2" to 3" is tapered at the end of which the cutting edge is made. A typical cutting angle is 60° for ordinary mild steel. The cutting angle is changed for other types of softer or harder metals. There are many other specific work chisels, like cross-cut, round nose, diamond point chisel.

Files: Files are used in nearly every metal and wood-working operation. They are made of very hard steel, having a large number of sharp edges or teeth which remove fine chips of material. The most common file is flat file. (Figs. 2 and 6). Other specific job files are square file, (Fig. 7); half round file, (Fig. 8); round file, (Fig. 9); and triangular file. (Fig. 10). The files can be properly stacked in a wooden rack. (Fig. 5).

Hacksaw: The hacksaw is used for cutting rods, bars and pipes into desired lengths. It consists of a narrow blade of good, hard, tempered alloy steel with set teeth, held in a metal frame, having a wing nut to apply correct tension on the blade. (Fig. 12).

The action of sawing is very similar to that of filing. Hold the handle in the right hand and the front end of the frame in the left. Place the feet, so that the body is well-balanced. Start sawing gently at the mark keeping the blade slightly inclined horizontally and in line with the guide-line. Proceed with light pressure and steady strokes, and gradually bring down the saw

to a horizontal position so that it cuts exactly along the guide-line. Keep the blade perfectly vertical and avoid twisting it side-ways. Use the full length of the saw at each stroke. Apply sufficient pressure on the forward stroke to make the teeth cut, but no pressure should be applied at the backward stroke.

Hand Drill: Hand drilling machine (Fig. 15) are used for holding drill bits and for drilling jobs. The flat drill bit (Fig. 14) is held in the chuck provided at the bottom of the machine. The handle is rotated, which revolves the chuck and the drill bit through bevel gears. The whole machine is pressed hard on the job to be drilled, which must be held in a vice. The handle is then rotated to drill hole. The twist drill (Fig. 13) is used mainly in power-driven drilling machine.

(Figures of the tools described below relate to Plate XIII A)

Ratchet Brace: A ratchet brace (Fig. 1) is used for turning a drill by hand. It consists of a drill holder, ratchet and handle and feed screw, which enables the distance between the top of the drill and the centre of the head to be increased or reduced according to requirement, when the brace is clamped in position. Use a try-square to check that the drill is perpendicular to the face of the work.

Tongs: Tongs are used to hold jobs or material being worked upon. Fore-bit tongs (Fig. 2) are used for holding flat jobs. Hollow-bit tongs (Fig. 3) are used for holding round rods.

Pliers: The pliers are used for holding jobs and for bending thin wires. (Fig. 6, 7 and 8). They are also provided with sharp edges for cutting thin wires. They are of many types, long-nose (Fig. 8), round-nose (Fig. 7) and side-cutting pliers.

Snips and Shears: Snip and its larger version called shear (Fig. 9 to 13) are used for cutting sheet metal. They are provided with bent handles, so that one handle can be held rigid in a vice, while cutting. The blades should be sharpened to an angle of about 87° while cutting. Hold the shears in the right hand and the sheet metal in the left. The shear should not be allowed to close completely, as the points may leave marks on the cut edge as in Fig. 14.

Spanners and Wrench: Spanners are used for tightening and loosening nuts and bolts. They are made of cast steel and should have their jaws set at angle with the shank or body. The size of the spanner is usually indicated by the diameter of the bolt it is intended to fit. A $1/2$ in. spanner is used for a $1/2$ in. dia. bolt and the width of the jaw is $1\ 1/2$ times the dia. of the bolt plus $1/8$ in. approximately. (Fig. 15, 16). Ordinary spanners are either single ended or double ended. They are available in a great variety of sizes and shapes. Each metal workshop keeps a range, suitable to the need, neatly stacked in a tool box or cupboard.

A wrench is a kind of single-ended spanner meant for specific purposes. Slide wrench (Fig. 22) can be adjusted to suit a range of sizes of bolts. But they are less efficient owing to backlash and side play. Fig. 20 shows another type of adjustable wrench. Fig. 18 and 21 show pipe wrench, which is very useful for opening or tightening pipes, and plumbing jobs.

Box-Spanner: These are used for recessed nuts which cannot be reached by ordinary spanners. (Fig. 19).

Small tools are being exported from India to a number of countries where there is a great demand for them.

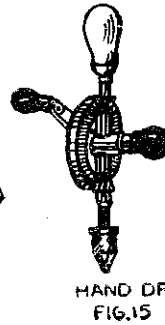
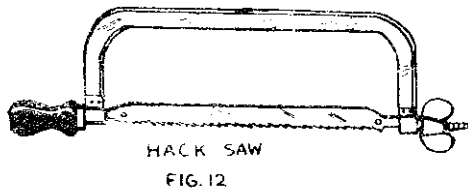
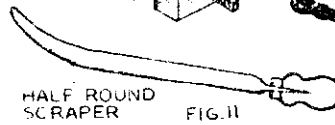
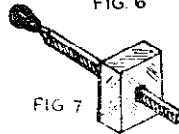
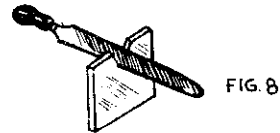
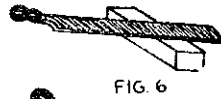
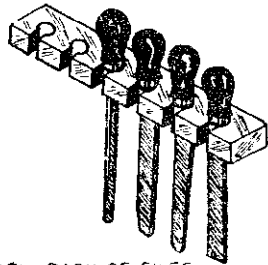
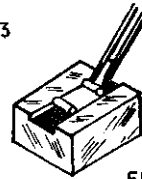
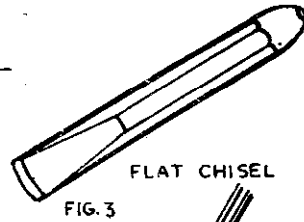
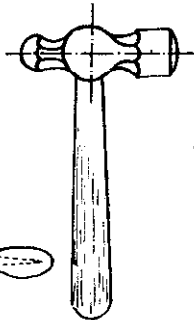
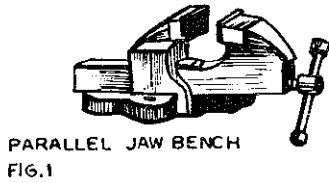

HAND TOOLS FOR METAL WORKING

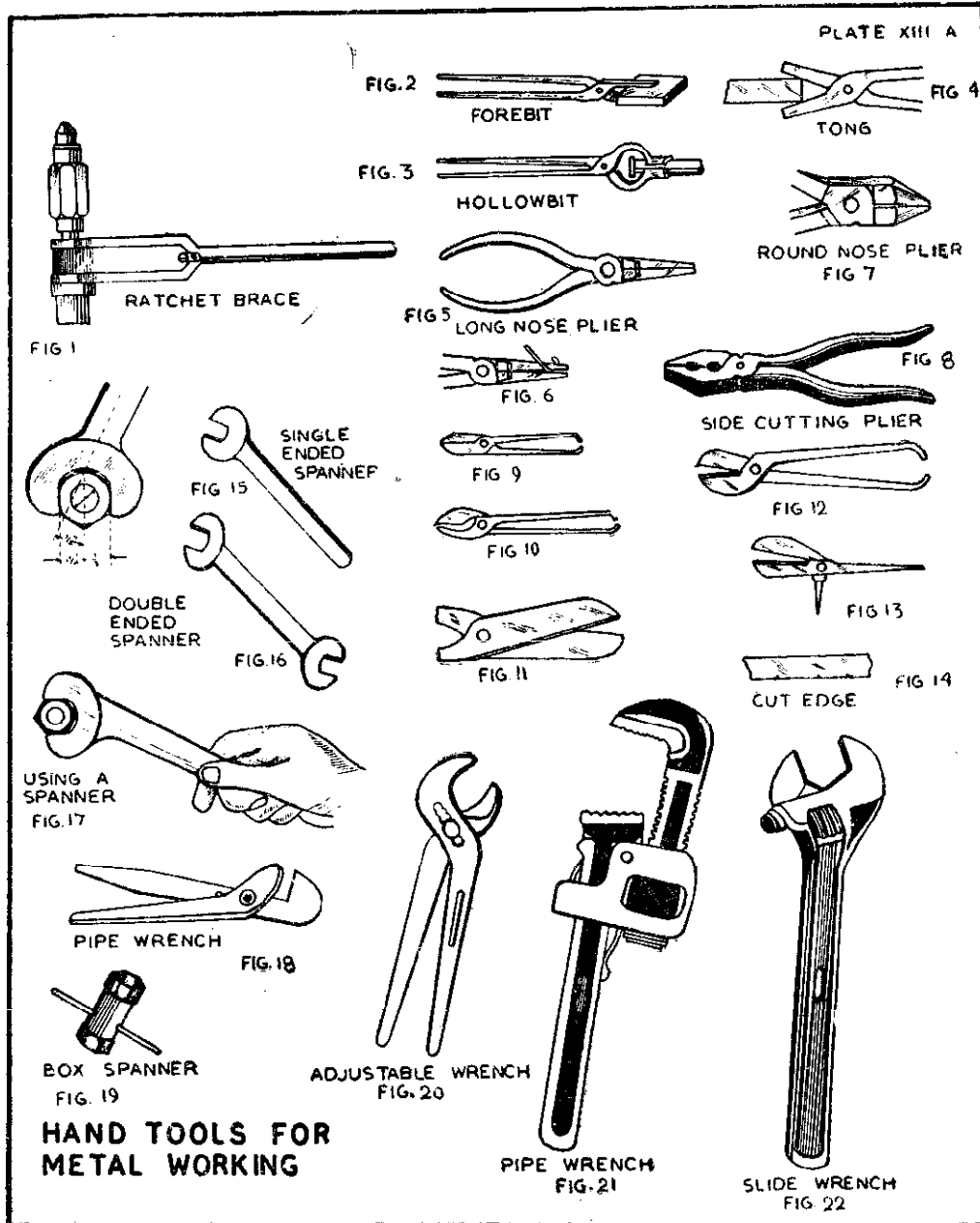

CARPENTERS' TOOLS

(Figures relate to Plate XIV and XIVA)

Introduction: There is a large army of carpenters in the villages. At present, they eke out a meagre living because of the inadequacy of their tools and insufficiency of demand. It has been experimented at many places, specially by Anna Saheb Sahastrabudhe near Wardha where he was able to increase the earnings of carpenters many-fold by just giving them a correct set of tools which they were not using previously. By increasing the range of their tools they can take up new jobs and make furniture and other sophisticated articles in demand these days. In the following paragraphs, some of the important tools which can be used by carpenters in the villages are described. They can be bought from any recognised tool shop.

1. Wooden workers' bench and bench vice

The dimension of the bench depends upon the space available but it is generally 10' to 12' long to accommodate large jobs and is 27" wide and 28" high. The top of the bench consists of boards about 1" thick, (Fig. 1), whose edges are stiffened by $9" \times 1\frac{1}{2}"$ vertical boards.

2. Carpenters' bench vice

It is fitted at one end of the table in which jobs can be held for working on it. The inside faces of the iron jaws must be lined with pieces of hard wood which is held in position by countersunk screws, so that job held between them is not damaged. (Fig. 2).

3. Chisel

The carpenters' chisel is known as firmers' chisel which is shown in Figures 3 and 4. One face of the chisel is nearly straight and the other edge is bevelled making angles of 10° to 35° with the main face. The blades of firmers' chisel are made from cast-steel and vary from $1/8"$ to $1/2"$ in width. This chisel is very useful for cutting out extra wood, making grooves and doing other fine work. It is always used with a mallet or wooden hammer. However, no mallet is used for pairing. For vertical pairing, grasp the handle firmly and use the necessary downward pressure. For horizontal pairing, press the chisel forward with right hand and guide it with the left hand. The strips are paired off in $1/10"$ thicknesses.

4. Hammers

Steel hammers are used mostly for striking nails and punching. On one side of it, there is a claw made, which is used for pulling out nails. It is, therefore, called a claw hammer. (Fig. 5 and 6). This hammer should not be used for striking wooden objects because it will damage the surface.

Mallets are made of wood and are used for driving firmers' chisel, for fitting, for knocking light frames together and to do other operations in which wooden pieces have to be struck. Fig. 9 shows the shape and size of the mallet and its use.

5. Planes

A plane is used chiefly to make wooden surfaces smooth, after they have been sawn to approximate dimensions. Basically, a plane consists of a chisel fixed at an angle in a wooden box with a cutting edge projecting through the bottom. There is arrangement for adjusting the projecting edge according to the thickness of the piece to be scraped out from the surface. The jack plane is about 17" long by 3" square in cross section and has a handle mounted on the stock just behind the plane-iron. This handle is held firm in the right hand with the forefinger resting on the wedge. The left hand grasps the stock in front of the wedge. The right hand thrusts the plane forward while the left hand presses the stock downward. Steady deliberate strokes are used, decreasing the pressure on left hand and increasing that of the right towards the end of each forward stroke. The cutting edge must not be allowed to reach the farther end of the work as it is likely to tear into the wood. Reverse the work and plane it from the opposite end. (Fig. 7).

6. Shooting boards

A shooting board, (Fig. 8), is used for shooting or trimming the edges of the wood. It is set against the bench stop. The work is so placed that it projects beyond the stop and is held tightly while the plane is worked on its side by the other hand.

7. Hand saw

The hand saw is a cutting tool consisting of a thin metal blade which has a series of sharp teeth on one edge. (Fig. 10). The blade is generally about 26" long and 7½" wide at the handle end and 3" wide at the front. It has 5-6 teeth to an inch. It is generally used as a cross cut, i.e. for cutting across the grain of the wood.

8. Tennon saw

Tennon saw is used for making fine smooth cuts across the grain, particularly when cutting the shoulders of a tennon. The blade is 14" × 18" long and 3" × 4" wide. It has about 12 teeth to an inch. (Fig. 11).

9. Pincers

Pincers are used for pulling out nails from the wood. (Fig. 4). The correct way of using a pincers for driving out nails is shown in Fig. 2.

10. Brace

The purpose of a brace is to facilitate boring of holes through manual operation by revolving the boring tools. (Fig. 1). They are made of wood or steel. The one made of steel lasts longer.

The brace has a socket which can be adjusted to hold any type of bit. It is used for boring holes for rails, screws or pins and for cutting larger circular holes. It can be used to bore holes horizontally or vertically.

11. Straight edge

Straight edge is a strip of well seasoned wood 2" or 3" wide having atleast one edge perfectly level and true. (Fig. 2). It is used for ascertaining whether a surface is uniform and even. This is done by laying the straight edge on the surface of the wood to be tested. Unevenness is shown by the spaces between the two surfaces in contact. (Fig. 3).

12. Try-square

Try-square is used for testing the squareness of the angle and surface to find out whether two edges are at right angle or not. (Fig. 5). It consists of a steel blade fixed at right angle to an edge of a wooden stock, the latter usually having its square edge faced with brass to make it more durable. It is also used for making parallel marks on wood pieces. (Fig. 6).

13. Ruler

A carpenter's ruler is generally folded into four. It is made of box wood and is 2 feet long and can be folded into a 6" long piece which can be easily carried in the pocket. (Fig 7). It is used for measuring and marking. It is always better to measure from one of the intermediate dimensions and not from the end of the ruler because generally they get worn off.

All the carpenters' tools described above can be bought from a retail dealer at a total cost of about Rs. 500.

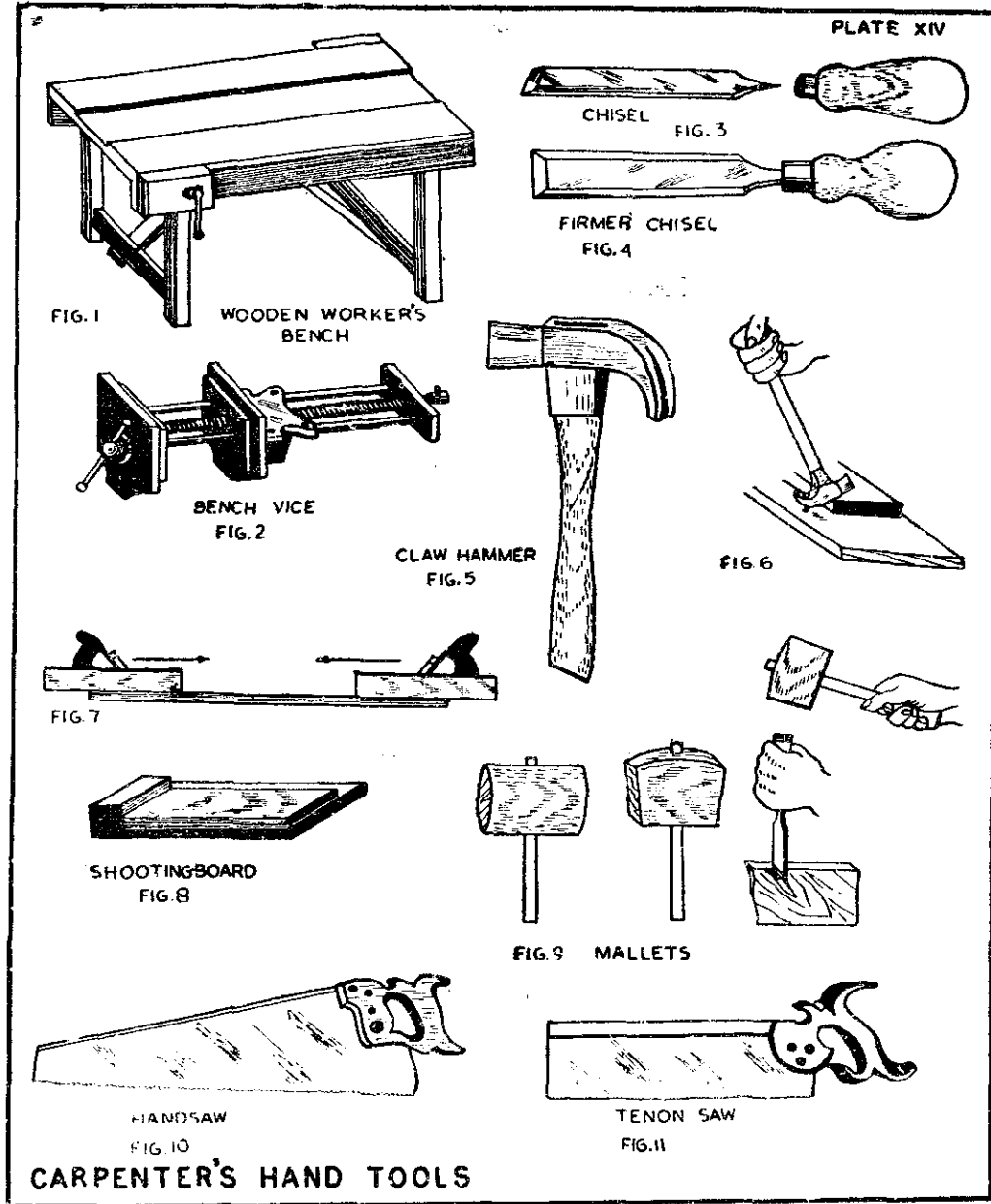

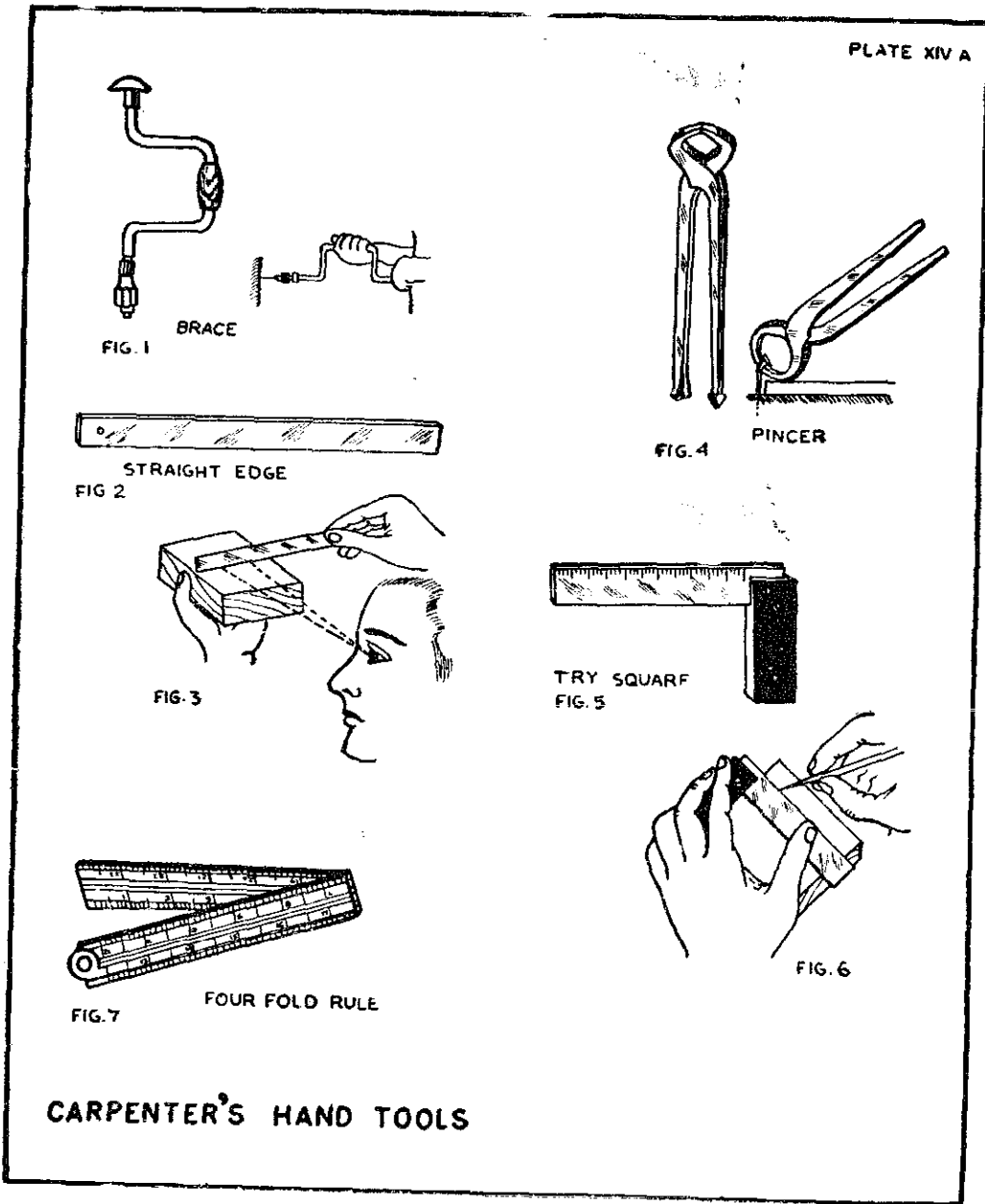

RURAL OIL DRUM FORGE

(Figures relate to Plate XV)

Contact Agency: I. T. D. G. Project, Zambia.

Introduction: Oil Drum Forge is a very useful equipment for rural blacksmiths. It gives them a handy and convenient forge, which can be placed anywhere they like. The design is such that it can be easily made by a rural blacksmith with waste material using his own tools. It does not require any welding or pressing of the parts as these processes are usually not possible to carry out in the rural areas. It can also serve well in any training programme with particular reference to small-scale industrial development. Since the forge is foot-operated, it leaves the operator's hands free to attend to his work and the fire. He can work standing instead of squatting on the floor.

Construction: The material required for fabrication is given below:

Wood

One 1100mm. × 50 mm. × 75 mm. (43" × 2" × 3")

One 300mm. × 38 mm. × 50 mm. (12" × 1½" × 2")

Blockboard

1 m.² × 18 mm. (39" × 39" × ¾")

Steel

13 mm. mild steel rod 126 cm. long (1/2" × 66"). One plate 40 mm. × 6 mm. × 760 mm. (1½" × 1/4" × 30"). Two metal sack lables 90 mm. One plate 60 mm. (3½" × 2-3/8") × 25 mm. × 6 mm. × 15 cm. (1 × 1/4" × 6"). One 45.50 gall. old oil drum 21.5 cm. × 25.5 cm. (8 1/2" × 10") × 18-20 swg

Pipe and fittings

One pipe 1140 mm. × 13 mm. (45" × 1/2"), Four 90° bend's 13 mm. (1/2"); one socket, reducing 23 mm. to 13 mm. (1" to 1/2"); one F × F elbow 25 mm. (1"); one M. × F elbow 25 mm. (1"); two nuts 25 mm. (1"); two nipples 25 mm. (1"); two nipples 13 mm. (1/2"); one socket 13 mm. (1/2").

Canvas: 1.092 m. × 30.5 cm. (43" × 12")

Plastic Sheet: (use old fertilizer bag (1100 mm. × 305 mm. (43" × 12"))

Old packing case banding (1150 mm. × 13 mm. (45" × 1/2"))

Nuts, bolts, screws, nails

Screws: 1/2 gross 50 mm. × 9 gauge (2" × 9 g). 1/2 gross 10 mm. × 3 gauge; (3/8" × 3 g)

Bolts/nuts:

1/2 gross 6 mm. × 38 mm. (1 1/2" × 1/4")

Nails, drawing pins

One box drawing pins; large head tacks, box.

Other Materials

Old car or cycle inner tube. 20 kg of anthill soil. 30 cm. × 30cm. of mosquito netting (used).

Building the forge: An old 44 gallon oil drum is taken. The central portion of the oil drum is cut into halves and the portion removed as shown in Fig. 2. The bellows are fitted in the hole, which has been cut in the drum. The sharp edges left after cutting should be either filed smoothly or turned inward.

Bellows: The bellows are made as shown in Figure 3. The material for the bellows must be airtight. Leather is better suited but may be expensive. Canvas can be treated to make it airtight. If the canvas is lined with a tough plastic sheet on the inside, the bellows can be airtight. Strips of canvas lined with plastic of a size 109cm × 30.5cm (43" × 12") are cut. Before the material can be fitted, the top and the base must be finished. The air inlet holes should be drilled with great care, without splitting the wood into holes. The valve flaps can be made from any thin sheet metal but it must be thin enough so that it may be lifted sufficiently to let in and out a full volume of air. The thin metal label tags used on sacks are quite suitable. They are fixed in such a way that they cover all the holes. The screws of the holding down strips do not go through the flaps as this tends to buckle them.

Fix the pivot bracket to the bellows top, make up the outlet box fixing to the underside of the bellows base so that the valve flap is central and the outlet hole is facing outward. The edges of the outlet box can be made airtight using soft shoulder or patti. The bellows base is fixed to the base wood with four screws. The bellows inner plastic is attached to the base with drawing pins at regular intervals. Make sure the pivot bracket is parallel to the base wood. The free ends of the plastic should be folded together as many times as possible and stitched.

The outer canvas is fitted in the same manner using steel banding about 13 mm. wide with small holes punched at 25 cm. intervals. Nail the binding in place using large headed tacks. Pumped by hand the bellows should now function.

Pipe work: Make up the pipe as shown in Fig. 4 and fit to the drum bellows. The blast nozzle or blower threaded 13 mm. pipe about 10 cm. long with one end closed. Drill about 20 holes of 5 mm. each along top and side to spread the blast.

Fire hearth: Bricks for the fire hearth can be made from crushed anthill soil. They should be 50 mm. × 50 mm. × 20 mm. in size. Lay them in the drum while still wet. Mould some clay round the bar pipe to protect it.

Return spring: If a suitable spring can be found, it should be attached to the pedal arm at a point between the pivot bracket and the first bend, the other end of the spring being hooked on the crossbar above. If a spring is not available, a suitable length of old car inner tube will do; use enough to give the desired amount of resistance and spring back.

Completed oil drum forge is shown in Fig. 1 of Plate XV.

In use: The forge starts very easily by using a little paper, wood and charcoal. The best result from the bellows is obtained by pumping slowly, long deliberate strokes. Once the fire is lit and all the paper is burnt out, the fire will remain alight for many hours. A few pumps will bring it to the working heat.

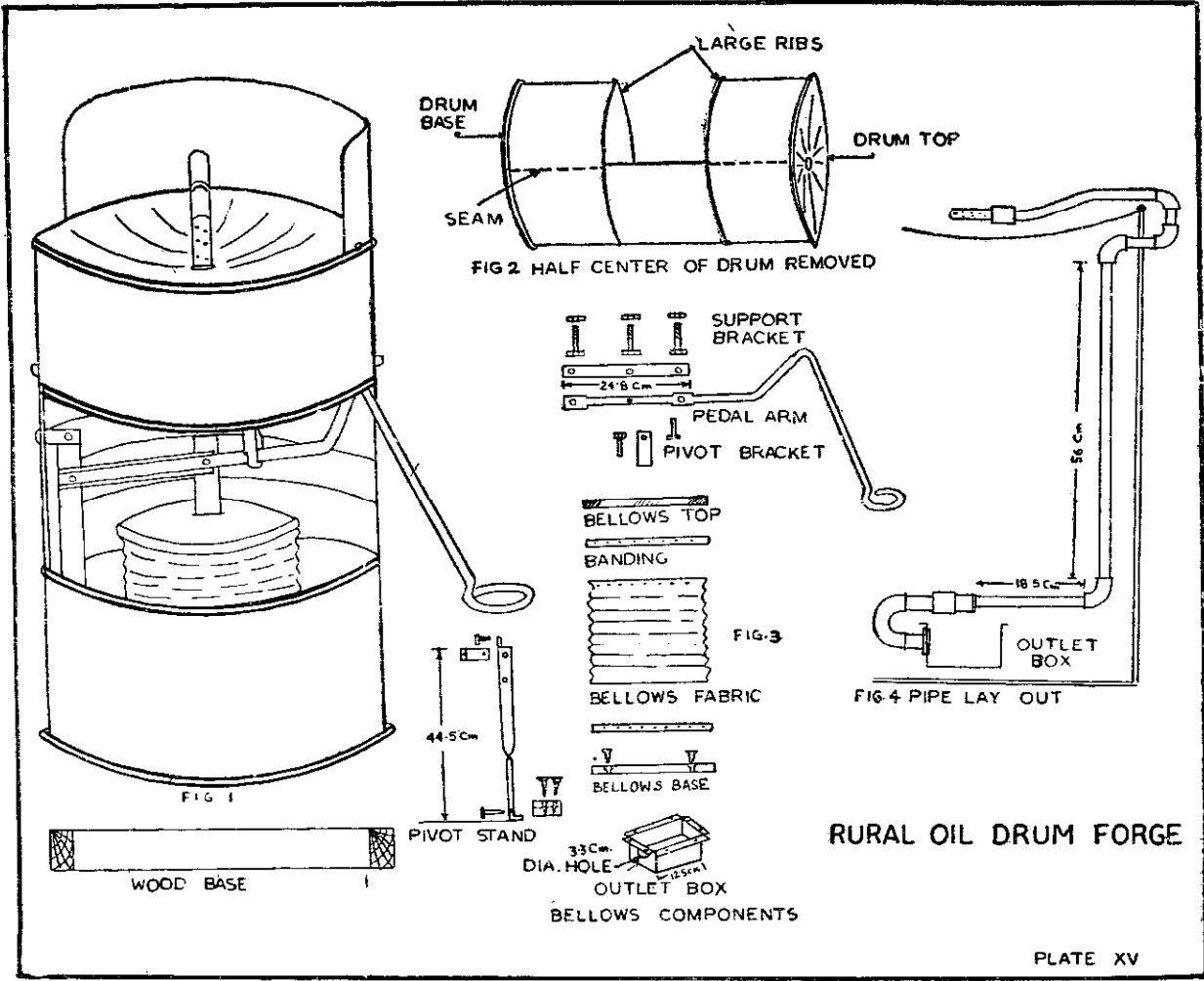

DRILLING MACHINE HAND-OPERATED

(Figure relates to Plate XVI)

Introduction—Drilling of hole is a great necessity in a mechanical workshop. Whenever some mechanical job is to be performed without a suitable machine, it becomes very difficult to drill a hole be it in wood iron or steel. There is a very simple design of a drilling machine which does not need any electricity and can be operated manually. The drill bits are needed, however, to drill any size of holes.

Construction—There is a pedestal frame on which the machine is mounted. On the upper side of the frame, a rotating handle and a bevel gear are mounted on the same axis. A large bevel gear meshes with a smaller bevel gear which is placed horizontally on the axis on which drill holding chuck and pressure screw are mounted. Drill chuck holds the drill bit. The whole vertical axis revolves with the small bevel gear. Figures show the front view and the side view of the machine.

How to operate—A piece of material in which the hole is to be drilled is mounted on the pedestal on a suitable device which holds it tightly and an appropriate size of drill bit is attached to the chuck. The screw is rotated by means of the upper handle so that the drill bit sits tightly on the material on the punched spot. The handle is then rotated by hand and the upper screw is slightly lowered so that the drill bit presses on the spot where the drill has to be punched. After some time the hole is drilled and the drill bit is taken out.

The cost of fabricating such a drilling machine by means of scrap parts is about Rs.100

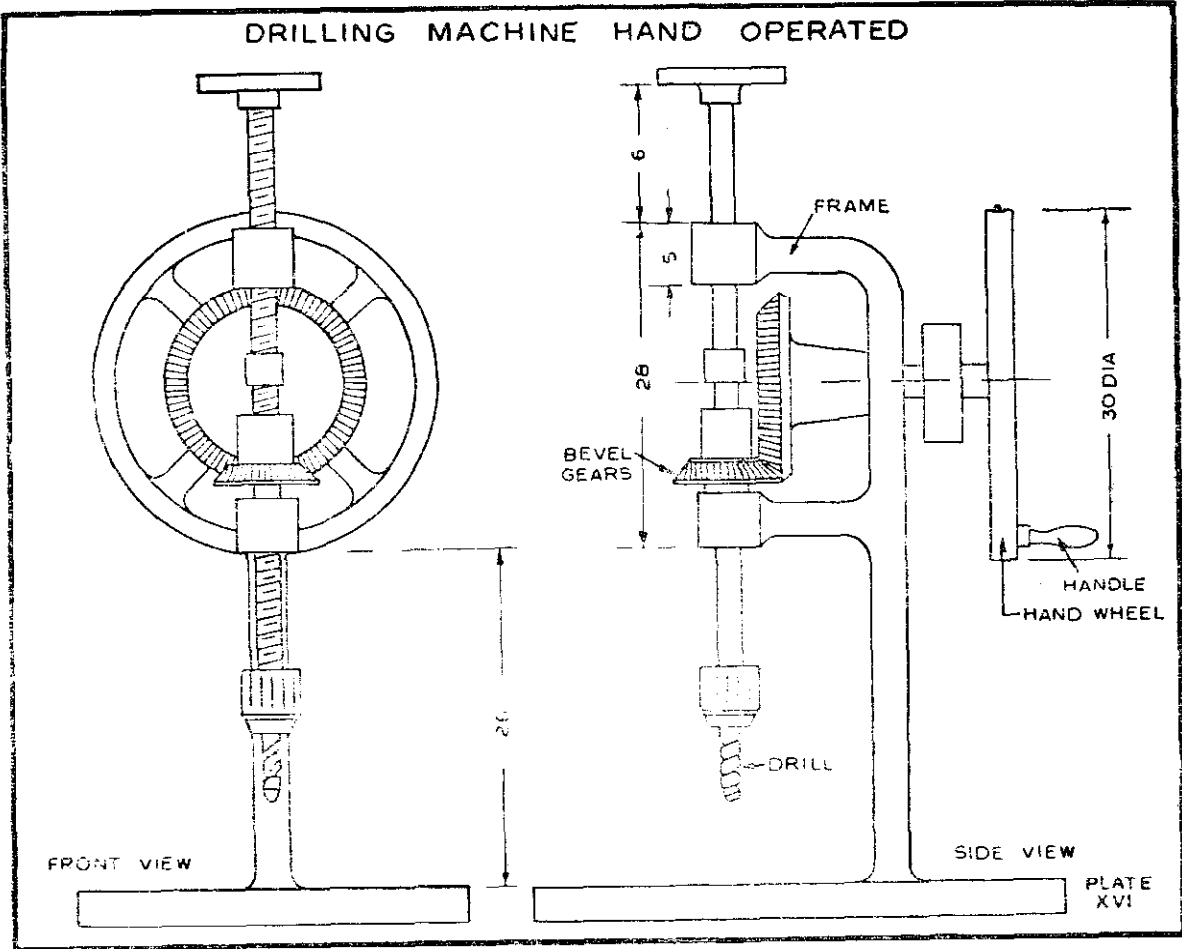

METAL BENDING MACHINE

(Figures relate to Plate XVII)

Contact Agency: Intermediate Technology Development Group Ltd., 9, King Street, London W.C. 2

Introduction : The establishment of blacksmith and metal working facilities in the rural areas is essential wherever local construction and maintenance of equipment for small farms and local use are required. The metal bending machine as developed by the I.T.D.G., London uses a very old principle. This low cost pivot principle hand operated machine can be constructed locally, since it is fabricated of easily available mild steel flats, angles, bars and pipe material. The machine's main feature is its ability to form wheel rims from cold flat mild steel up to $4" \times \frac{3}{8}"$ (100 m. \times 10 mm.) cross section, for use on bullock-carts and other basic agricultural equipments. It can also be used for bending notched angle iron and flat mild steel to whatever angles are required.

Construction : The basic machine consists of a fixed arm. It is bolted to two pieces of channel F (Fig. 1), the latter provided with holes at both ends and intended to facilitate mounting of the machine on a bench or other solid surface. The pivoting arm B (Fig. 2) which controls the metal bending operation is fitted with a handle E and pivot pin G, which can be placed in any of the nine position holes to fix the arms about the required point (Fig. 3) according to the bending work involved.

The circle bending former H is originally built with a bending surface curve of 14" radius to head a hoop of 33" nominal dia. A circle bending former of $12\frac{1}{2}"$ radius gives a wheel rim of 30" dia.; which is used in a standard bullock cart.

List of Parts

Part	Name	Quantity required	Dimensions	Material
A	Fixed arm ..	2	12.5 \times 76 \times 762	M.S. flat
B	Pivoting arm ..	2	12.5 \times 76 \times 762	M.S. flat
C	Fixed arm box ..	2	135 \times 76 \times 76	M.S. angle
D	Pivot arm box	2	105 \times 76 \times 76	M.S. angle
E	Handle ..	1	35 dia.	M.S. bar 508 long.
F	Mounting supports	2	76 \times 38	M.S. channel 508 long
G	Pivot pin ..	1	25 dia.	M.S. bar 229 long
	Fixed arm bolts	2	22 dia.	190-200 long
	Mounting support bolts	4	20 dia.	length to suit
H	Circle bending	1	16 \times 101 \times 340	curved to 336 radius
		1	12.5 \times 76 \times 279	M.S. flat.
		2	12.5 \times 51 \times 101	M.S. flat.
		1	25 nominal bore pipe 101 long	

(All dimensions are in mm.)

Assembly : 1. To construct the fixed arm A, two pieces of 12.5 × 76 × 762 mm. mild steel flats are clamped one on top of other and nine 25 mm. dia. pivot pin holes and two 22 mm. dia. bolt holes are drilled through both pieces. Two pieces of angle forming the box are placed in position between the drilled flat, 25 mm. diameter bars placed through pivot pin holes nos. 1 and 9; a 135 mm. distance piece placed at the outer end of the box and 22 m. dia. bolt tightened to ensure precise alignment, following which the angles are welded all round and to the flats to form the box.

2. For building the pivot arm B, the two pieces of mild steel flats are drilled in similar manner and the angle iron fixed at one and welded all around.

3. Two machine mounting supports F are drilled with one 22 mm. dia. holes and two 20 mm. dia. holes.

The total machine with various parts is assembled as shown in Fig. 1 to 5.

How to operate : The circle bending former is placed in position, the pivot pin passing through hole no. 5 in the machine arms. A material grip former is placed centrally on top of the distance piece both being held in hole no. 8 position in fixed arm by fitting pins.

The cylindrical roller K is held in hole no. 8 in the pivoting arm by filling pin P.

The machine is now ready for bending operation.

Take a piece of 100 mm. × 10 mm. black mild steel flat and cut it to 2565 mm. length. One operator pushes at a 1830 mm. length of 38 mm. bore pipe over the pivoting arm for better leverage. The pivoting arm is swung back, so that fittings are well clear of the circle bending former and the second operator inserts one end of the mild steel flat in between the fittings and the curved former. The bending then proceeds, when the first operator releases the grip on the material by drawing the pivot arm backwards, the second operator pushing the material past the former by about 50 mm. (2"), every time. The cylinder roller is then forced hard against the curved former. It is better to give initial curvature to the end of the M.S. flat by hand, to facilitate easy bending.

The bending operation continues in this manner by approx. 50 mm. (2") steps until a length of about 305 mm. (12") has been curved. The material is then taken out and the same initial bending procedure applied to the other end for a distance of about 306 mm. (12"). The material is then re-inserted into the machine and the bending operation continued as illustrated in Figs. 6, 7, 8 and 9. The total length of the material should be 2387mm. (94") for a wheel of 750 mm. (30") dia.

The machine can also be used by inserting suitable formers

- (a) to bend notched angle iron to any angle upto 90°,
- (b) to bend mild steel flats to any sharp cornered angle upto 90°,
- (c) to bend mild steel flats to a smooth curve cornered angle upto 180° by bending directly around pivot pin G.

The bending machine design can be modified to suit the local availability of steel stock sizes and can be further developed by addition of other types of formers and fittings to expand its usefulness to other bending operations, which may be locally required according to the types of rural equipment to be manufactured.

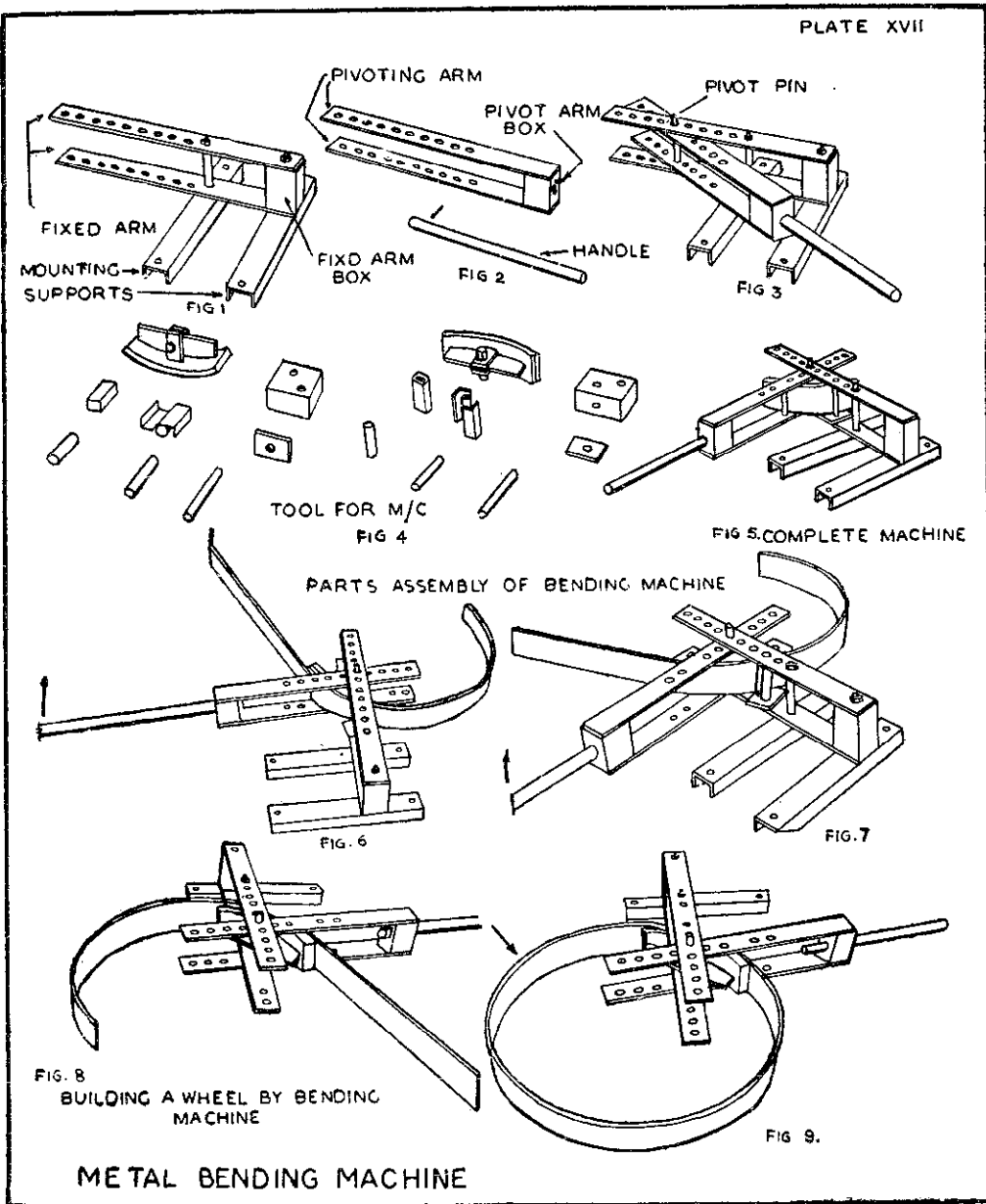

Agro-Processing

INTRODUCTION

Agro-processing is a term generally used for processing of agricultural commodities. Making of flour, dehusking of rice, extraction of oil, manufacture of jaggery and sugar are the processes included in this subject. There is vital need to develop appropriate technology in this field of activities so that the raw materials produced in the villages could, as far as possible, be processed there instead of being transported to towns and cities where such operations are carried out on large scales and the products are handed back to villagers for domestic consumption. Such a step will ensure that maximum employment is provided to the rural people. The value added to the produce due to processing will increase, thereby giving higher income to the agriculturists.

To make such operations meaningful, and competitive with the large processing units set up in the urban areas, it is necessary that the technology used should be of viable nature. Thus there is need for developing appropriate technology on processing by competent technologists of the country. There is a wide scope for it in agro-processing depending upon the type of agricultural production carried out in different parts of the country. A few examples have been illustrated in this section but there is a real need for collecting a large number of other cases and items on the subject, which could be very helpful in improving the economy of the village.

PADDY THRESHER

(Figures refer to Plate XVIII)

Introduction: Paddy is one of the main crops in India. Once it matures in the field, a number of processes starting from harvesting, threshing to de-husking have to be carried out on it as quickly as possible. One method of threshing paddy is to lay it on the ground and let the bullocks walk on it for days and days so that the grains leave the stalk. But the most common method is beating the stalk with wooden sticks. Naturally it is a very laborious and time consuming process, due to which there is also loss and damage to the grains. Some attempts have been made to design suitable paddy threshers in which paddy is easily and quickly threshed by machine. The equipment described below is one of such types.

Description : This is called 'Japanese Type Paddy Thresher.' It has got two rollers mounted on a frame which can be operated by a pedal. The paddy stalk is fed between the rollers which have got raised portions all over and the pedal is operated by foot. The threshed paddy falls on the other side and is collected in the bag. If there is any paddy left in the stalk, it can be fed another time until all the paddy grains are taken out.

The cost of this equipment is about Rs. 200/- and is available from almost all agricultural implement dealers. It is shown in Plate XVIII.

PLATE XVIII

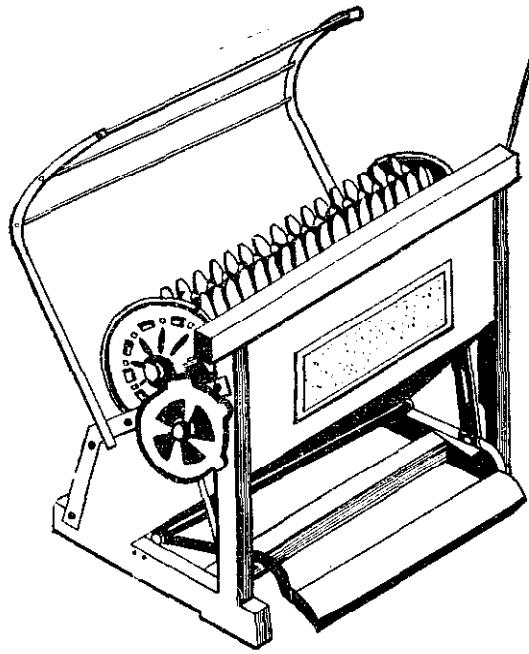

PADDY THRESHER

EQUIPMENT FOR PARBOILING PADDY

(Figure relates to Plate XIX)

Contact Agency: Gram Nirman Mandal, Sokhodeora, District Nawada, Bihar.

Introduction : It is customary in the eastern part of India to eat parboiled rice (known as Patna rice in western countries). There is no suitable cheap equipment available for parboiling paddy. Generally parboiled rice is processed in large mills, provided with expensive equipments. This is an equipment developed by trial and error method in a small integrated rural development organisation (Ashram).

Construction (i) Drum : It is made from an old 200 litre (44 gallons) oil drum. Cross rods are welded on to the inside of the drum at about 1/3rd of the height from the bottom. On the cross rods, a sieve with small holes, made from an M.S. Sheet of 16 swg., and of approx. the same dia. as the drum's inside dia. which can loosely fit inside, is placed. A small door is provided in the middle portion to check whether the paddy has attained the desired softness and also to take out the paddy after parboiling.

(ii) **Oven :** The oven for this purpose has been specially designed by the Ashram after several trials and errors. This economises fuel consumption and gives the best heat. The coal or wood is kept on the fire grate and the fire is lit. The paddy drum is kept on the first oven, where the heat is maximum. Another oven is also provided for utilising the extra heat. The chimney is 16 ft. high and 10" sq. cross section.

How operated : The paddy to be parboiled is soaked in water and kept in the upper portion of the drum. There is water in the lower portion (1/3rd of the height). A sieve having small holes separates the two portions. When the drum is placed on an oven with the top covered by a gunny bag, the steam rises through the holes in the sieve and percolates through the paddy and thus steams it. The paddy can then be dried and taken to paddy de-huskers.

Price : Rs. 50 for fabricating an equipment and constructing a furnace.

The Central Food Technological Research Institute has also developed a parboiling process which can be used by big rice mills.

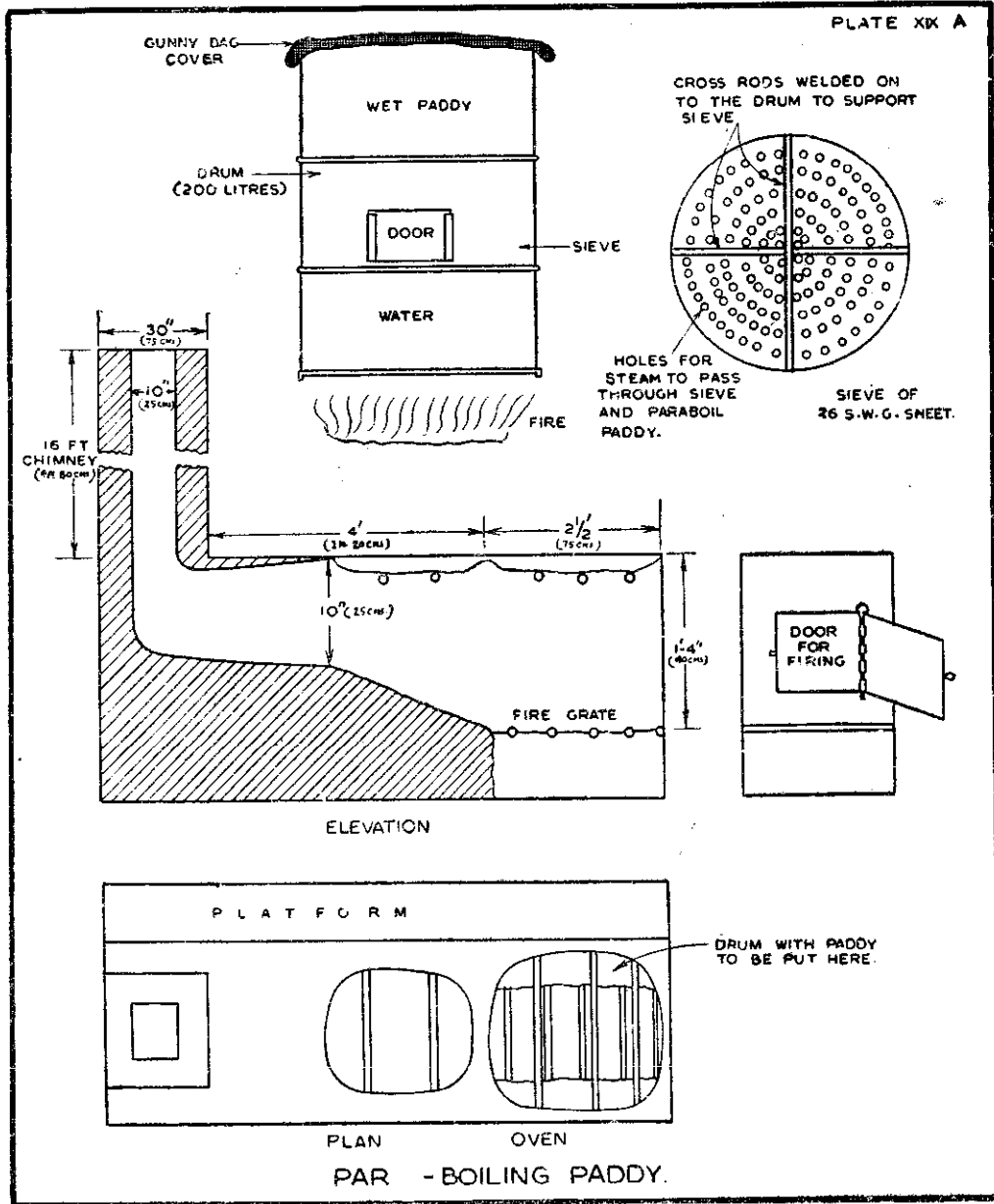

PADDY PROCESSING EQUIPMENT

(Figures relate to Plate XX)

Contact Agency : Kisan Krishi Yantra Udyog, Kanpur.

Introduction : There is a great need for small sized and cheap paddy processing machines to be installed in villages to stop the flow of this important agricultural produce from the countryside to large towns, where large-scale rice milling plants have been set up. Such machines can help the process of generating employment in villages and increase the income of the farmers who can sell rice instead of raw paddy. They can utilize the bye-products like paddy husk as fuel, the bran extracting for oil and for poultry feed. These bye-products can form the base of a new type of economic activity.

The description of two machines, most suitable for the above-mentioned purposes, developed by the firm is given below. They can be purchased directly from the firm.

I. Grain purifier: It is a sturdily built machine mounted on a trolley of angle iron for easy transportation. (Fig. 1.) There is also provision to install the machine on fixed foundation. It can remove large stones, chaff, hesian, etc. High velocity fans provided can remove light impurities like husk and immature grains. Three changeable vibrating services are provided for grading the grains. There is also provision for air control and stroke variation.

It runs by 1 H.P. electric motor either on 220 volts or 1.85 BHP, petrol or diesel engine. It consumes 0.75 units of electricity per hour.

The capacity is between 1 ton and 1 1/2 ton grains per hour depending upon impurities present.

Price: Rs. 4,075 with 1 H. P. motor and starter, ex-factory Kanpur, taxes extra.

II Composite unit :

It is a versatile machine, mounted on a trolley for easy transportation. (Fig. 2.) It shells paddy, polishes brown rice and separates husk and bran.

Automatic de-husking, polishing of rice along with separation of un-dehusked paddy, rice bran, fuel and cattle feed are carried out by this machine in a single operation. The recovery is 5 to 7% more with less breakage of rice compared with other units of the same size.

It consists of the following units:

- (a) Centrifugal type sheller. The diameter of the impeller is 30 cm.
It rotates in between rubber cylinders each of 1" thickness.
- (b) Under-run disc. polisher
disc dia.—42.5 cm.
speed of rotation—3300 r.p.m.
clearance between disc. is adjustable.

(c) Pneumatic separator

Centrifugal blower—40 cm. dia.

Blower speed—1440 r p.m.

Discharge—6.56 m.³

Duct dia.—12 cm.

It is run by 5 H.P. motor, or diesel engine and consumes 4 units of electricity per hour.

The capacity is about 150 kg./hr.

Size of the machine (165 cm. × 70 cm. × 165 cm.)
= Length × Width × Height.

Price: Rs. 8,500/- with 5 H.P. motor and starter ex-factory, Kanpur.

In addition to the abovementioned machines, the firm offers a range of following machines, which are also useful for small scale cereal processing:

1. Paddy dehusker—400 kg/hr. capacity 1 H.P. motor—Rs. 5,000
2. Paddy dehusker—1200 kg/hr. capacity 3 H.P. motor—Rs. 8,500
3. Rice polisher 300 kg/hr. capacity 3 H.P. motor—Rs. 5,000
4. Grader cum winnower 200 kg/hr. capacity 1 H.P. motor—Rs. 1,836
5. Grihlaxmi (grinding machine 6 kg/hr. capacity $\frac{1}{2}$ H.P. motor—Rs. 1,800 for wheat, spices, etc.).

PLATE XX

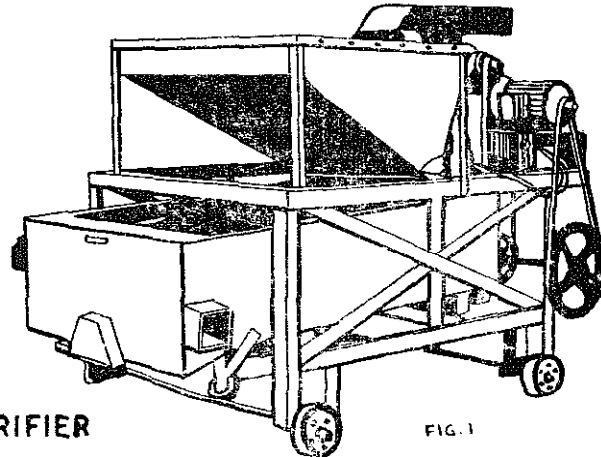

GRAIN PURIFIER

FIG. 1

POWER: REQUIRED 1 H.P. ELECTRIC MOTOR 220 VOLTS OR 440 VOLTS OR 1.85 B.H.P.
PETROL ENGINE.

CONSUMPTION: 75 UNIT PER HOUR.

CAPACITY: 1 TONNE TO 1/2 TONNES PER HOUR DEPENDING ON IMPURITIES PRESENT

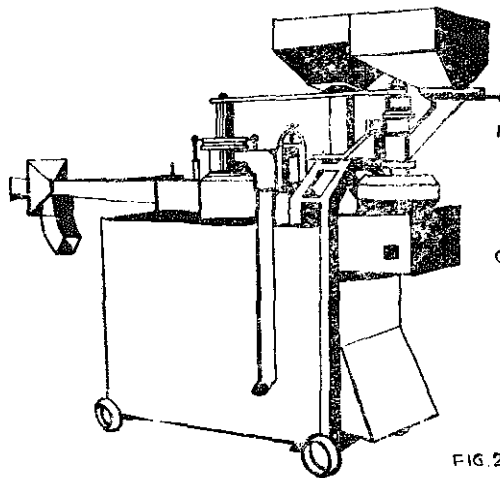

POWER: REQUIRED - 5 H.P.
(ELECTRIC MOTOR
OR DIESEL ENGINE)
CONSUMPTION -
UNIT PER HOUR
CAPACITY: 200 KG. PER HOUR

COMPOSITE UNIT

FIG. 2

OIL GHANI

(Figures relate to Plate XXI)

Contact Agency: Khadi and Village Industries Commission, Irla Road, Vileparle, Bombay-56.

Introduction : Oil seed is one of the very important crops in India and there is also a need for extraction of oil from the seed for domestic consumption in the village itself. Kohlu is an ancient type of equipment used to extract oil from the seeds. Oil extracted through it is regarded by many consumers as more wholesome than the machine extracted oil. The fact however remains that recovery through this operation is low and since it is carried out by bullocks it involves too much drudgery and monotony. The development of power ghani has been a great improvement on kohlu as far as the recovery of oil is concerned.

Description : Khadi and Village Industries Commission has developed a power ghani which is worked by a small motor and expels oil much faster without in any way spoiling the quality. A power ghani is shown in Plate XXI. The motor and pulley are fitted overhead which rotate an arm at the end on which a big round wooden block is fitted. It revolves inside a conical flask in which the oil seed is fed. The oil is collected at the bottom.

The price of this machine is about Rs. 100/- excluding motor.

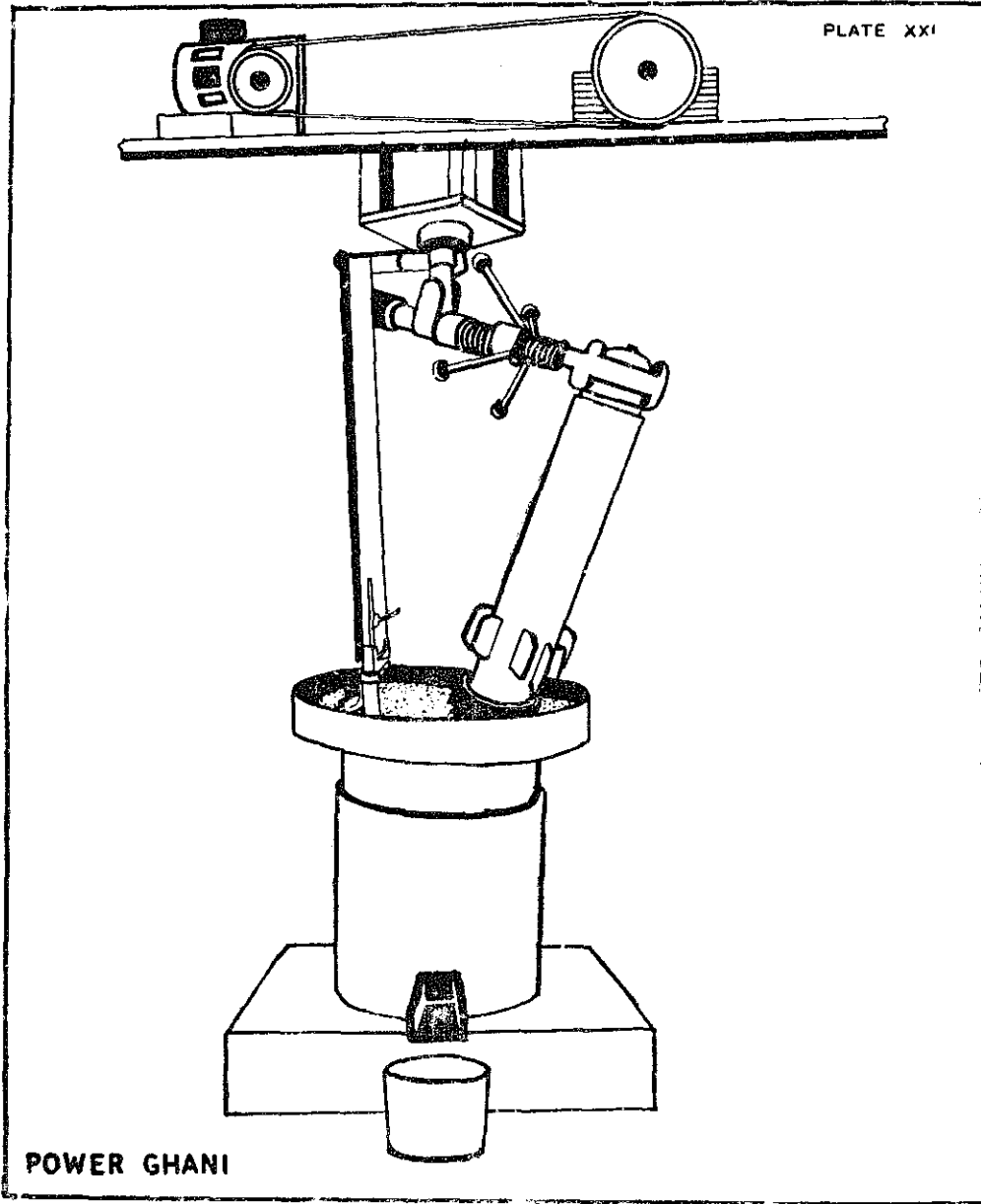

MINI-SUGAR PLANT

(Figures relate to Plates XXII, XXIIA, XXIIB, XXIIC, XXIID, XXIIE, XXIIF)

Contact Agency : Planning, Research and Action Division, State Planning Institute, U.P., Kalakankar House, Lucknow; and Garg Consultants, C-10/1, River Bank Colony, Lucknow, U.P.

Introduction : Crystal sugar manufactured from sugarcane is the most widely used sweetening agent in the world. In India, however, from times immemorial, *khand* a sort of raw sugar and *gur* or jaggery i.e. complete concentration of whole cane juice, were used. The process of manufacture was laborious, manually operated and time consuming, and the production capacity was low. White crystal sugar first imported from Java in the year 1905, became gradually popular. The industry manufacturing sugar by large scale vacuum pan method grew and now there are about 220 such mills in operation, manufacturing 48 lakh tons of white crystal sugar annually. In spite of this gigantic expansion it presses a maximum of 30—32% of sugarcane grown in India. The machine manufacturing capacity and other general considerations do not give hope that the large scale vacuum pan method of sugar manufacture would be able to press even 50% of sugarcane grown.

Sugarcane is grown in widely scattered areas in the developing countries which makes it imperative to develop a smaller technology by improving the old *khandsari* method of manufacture to utilise all the canes grown in scattered areas. A team, constituted by PRAI, Lucknow and headed by Mr. M. K. Garg, developed a technically feasible and economically viable appropriate technology which is producing the same quality of crystal sugar as of the large scale industry and competing with it in the market. It has found acceptance from a large number of middle class entrepreneurs and now there are 2600 units in India, producing 13 lakh tons of crystal sugar and growing at the rate of 30 units per year.

Methodology of development : A brief description of the methodology used for developing this technology is given below :

- (i) The PRAI team made a survey of various sugar processing technologies and identified the comparative gaps in efficiency in the old process of *khandsari* sugar manufacture;
- (ii) designed and developed new machinery and processes for narrowing these gaps and shortcomings;
- (iii) put up a pilot plant in actual field conditions and ran it on commercial basis;
- (iv) the result obtained from this pilot plant was thrown open for discussion in a technical seminar attended by prominent sugar technologists, economists, skilled workers, etc.;
- (v) the solutions suggested in the technical seminar were further worked upon with the help of a number of technical institutions, especially the National Sugar Institute, Kanpur.

The following table is taken from the case study made by Shri M. K. Garg, about the performance and efficiency of the various technological levels of sugar industry :

Table 1

Efficiency	Bullock crusher	3 roller power crusher	5 roller power crusher	Large scale vaccum pan mill
1. Juice extraction by weight	55-60%	58-62%	60-62%	73%
2. Milling efficiency	67-68%	68-70%	70%	89-92%

Table 2

Clarification system	Efficiency of removal of non sugar
1. Defecation by adding lime and followed by refining through carbon filtration ..	60%
2. Lime sulphitation	34-45%
3. Lime carbonation	50-55%
4. Indian system of bark clarification ..	10-15%

Table 3

Process	Purity drop	Sugar losses
1. Open pan	3.5	15%
2. Vacuum pan	2%

Table 4

Process	Percentage loss on the available sugar	Quality and type of sugar crystal
1. Static crystallisation ..	4-6%	Powdery
2. Crystallisation in motion ..	1%	Crystalline

The economic analysis based on the study made by Mr. G. G. Baron of I. L. O. is given below :

Table 5

Comparative overall efficiency

Technique	% of sugar recovered and bagged out of the total available sugar in cane at the time it was harvested
Large scale vacuum pan technique ..	75 to 80%
Indigenous khandsari	42 to 45%
Mini-sugar technology developed by PRAI or open pan sulphitation unit	57 to 64%

Table 6

	(a) Modern mill	(b) OPS* plant
Capacity (maximum crushing in tons/day) ..	1,250	80
Output in an average season (tons of sugar) ..	12,150	640
Investment required (land, buildings, plant and machinery (Rs. millions)	28	0.6
Total employment (permanent and seasonal) ..	900	171
Investment per ton sugar of output (average season)	2,305	940
Investment per worker	31,100	3,530

Table 7

Output and employment resulting from the same investment

	(a) Modern mill	(b) OPS plant
Initial investment (Rs. millions)	2.8	2.8
Number of units	1	47
Investment per unit (Rs. millions)	2.8	0.6
Total resulting output (tons of sugar) ..	12,150	30,280
Employment (permanent and seasonal) ..	900	9,937

*open pan sulphitation

Table 10

Cost of processing 100 quintals of cane (based on the working of 1971-72)

Items	Large scale vacuum pan factory (9.5% recovery)		Small scale technology (8% recovery)	
		Rs.		Rs.
1. Salaries and wages	164.35	..	151.00
2. Fuel and power	57.70	..	66.50
3. Stores and lubricants	103.23	..	62.80
4. Repairs and renewals	48.77	..	12.00
5. Depreciation	200.00	..	90.00
6. Overheads	39.23	..	10.00
7. Taxes :				
(a) Excise duty	123.50	..	59.70
(b) Purchase tax	50.00	..	50.00
8. Cost of cane	1,200.00	..	1,200.00
9. Transport charges on cane	47.50
10. Capital cost 10%	200.00	..	90.00
11. Cost of production per quintal of sugar	235.16	..	223.00

Technology : The sugar making process can be divided into four parts:

- (1) extraction of juice from sugarcane;
- (2) clarification of juice to remove non-sugar material;
- (3) concentration of juice to provide for crystallisation; and
- (4) crystallisation and separation of crystals from molasses.

The following illustrations indicate the processes and machinery used in the old method and the appropriate technology model developed now.

(i) *Crushing* : The old method worked on the extrusion principles. The equipment changed from stone crushers to crushers working on milling principle, to iron crushers or roller mills and, subsequently, to a five roller crusher. The milling efficiency was below 70%. (Fig. 1, 2, 3 and 4—Plate XXII).

This appropriate technology has developed a crusher consisting of 2 mills of three rollers each. It is with hydraulic loaded equipment and has arrangements for mechanical feeding and cane preparatory devices consisting of 2 sets of cane knives. Its milling efficiency has increased from 70 to 80%. (Fig. 5, Plate XXIIA).

Figure 6, Plate XIIA shows a new experimental sugar expeller being developed which would increase the milling efficiency to 87% in dry crushing.

(ii) *Clarification* : The old Indian method was to take out the coagulant from some vegetable bark and add to the juice in the open pan as shown in Fig. 7 and 8, Plate XXII B. The resultant which came on the top was removed and the juice was concentrated. In the new appropriate technology, the clarification agents used are lime and sulphur, the same which are used in large scale sugar factory. (Plate XXII C).

In large scale mills, sugar is boiled in vacuum, for concentrated solutions have a high inversion rate when boiled above 60°C. For small scale process open pan boiling was adopted because the vacuum pan boiling was neither economical nor feasible. The traditional furnaces prevalent in India were redesigned to reduce the inversion purity drop from 4 points in old mills to 1.5 points. Combustion chamber bel with heat recuperating devices was developed. (Plate XXII D).

(iii) *Crystallisation and separation of crystals* : In the *khandsari* system the masscuite was filled up in earthen pot for static crystallisation shown in Fig. 1, Plate XXII E. This was replaced by a newly designed crystalliser on the dynamic principle of crystallisation as shown in Fig. 2 of Plate XXII E. This enables better extractability of the molasses.

The crystals were separated from the mother liquor in the old process by masscuite into woollen bags, stacking them and putting weights. (Fig. 9, Plate XXII F). Part of the molasses was drained out and the sticky mass from these bags was put into a tank having a perforated bottom. The sewer grass obtained from water ponds was used for microbiological action. The molasses were drained out from the upper portion leaving non-crystallised sugar which was removed and then more sewer grass was used till the whole was clarified. (Fig. 10, 11, 12, Plate XXII F). This was a slow process and the extractability of the molasses was poor. The quality of the sugar was also not good. Introduction of high centrifuge as shown in Fig. 3, Plate XXII F gave better crystallisation of whiter sugar and better extraction.

General : Due to the success of this technology, a large number of enquiries are also being received from other developing countries specially Africa and South East Asia and a number of teams of various governments have come to study it. Some plants have also been exported.

In the year 1959, a workable technology was designed and disseminated. Private entrepreneurs were encouraged to take up the project and were offered facilities of turn-key jobs, free technical advice, training and post-installation services and advice.

Further researches in developing the sugar cane expeller promise to raise the milling efficiency to 85-87% as against 89-92% of the large scale mills. Similarly, research for the improvement in the open pan furnace and crystallisation may increase the overall efficiency to 70-74%.

The following firms are engaged in the manufacture of machinery in India:

1. M/s J.K. Iron and Steel Co.,
Kanda Tower, Kanpur.
2. M/s Cossul and Co. Pvt. Limited.
123/367, Industrial Area, Kanpur-12.
3. M/s Reliance Engineering Works,
G-6, Industrial Estate, Talkatora, Lucknow-5.

4. M/s Khandelwal Engineering Works,
Bahadurganj, Shahjahanpur.
5. M/s Rohilkhand Industries Pvt. Ltd.,
Izatnagar, Bareilly.
6. M/s Saran Iron and Steel Co.,
Mandi Bans, Moradabad.
7. M/s Meerut Engineering Works,
Rani Mills, Meerut.
3. M/s Maseys,
Engineers and Manufacturers,
Post Box No. 554,
Rayapuram, Madras.
9. M/s Choday Apparow Sugars and Engineering Works,
Jagannaickpur, Kakinada (A.P.)
10. M/s Adarsha Engineering Works,
Shrirampur (Ahmadnagar), Maharashtra.

There are a number of other firms which have specialised in the manufacture of special parts.

PLATE XXII

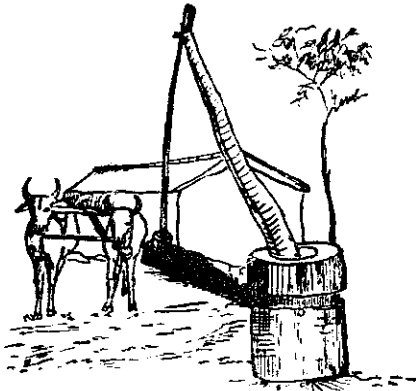

STONE BLOCK TYPE OF CANE JUICE
EXTRACTOR USED UP TO 1865 IN INDIA

FIG. 1

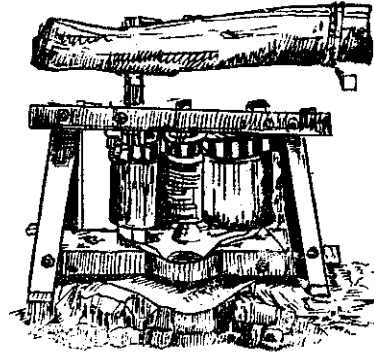

3 ROLLER VERTICAL CRUSHER INTRODUCED
IN INDIA SOME TIME IN 1865, FIRST AS
WOODEN MODEL LATER ON OF IRON

FIG. 2

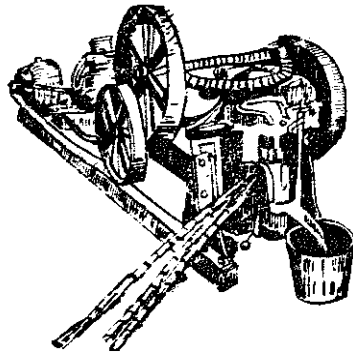

SAME TYPE OF CRUSHER
(MECHANISED)

FIG. 3

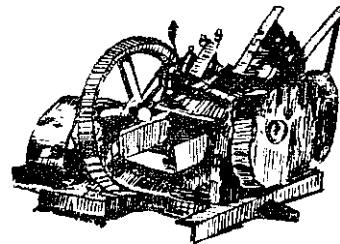

5 ROLLER HORIZONTAL CRUSHER FOR
HIGHER EXTRACTION
"MODEL SELECTED FOR FIRST PILOT
PROJECT AT GHOSI"

FIG. 4

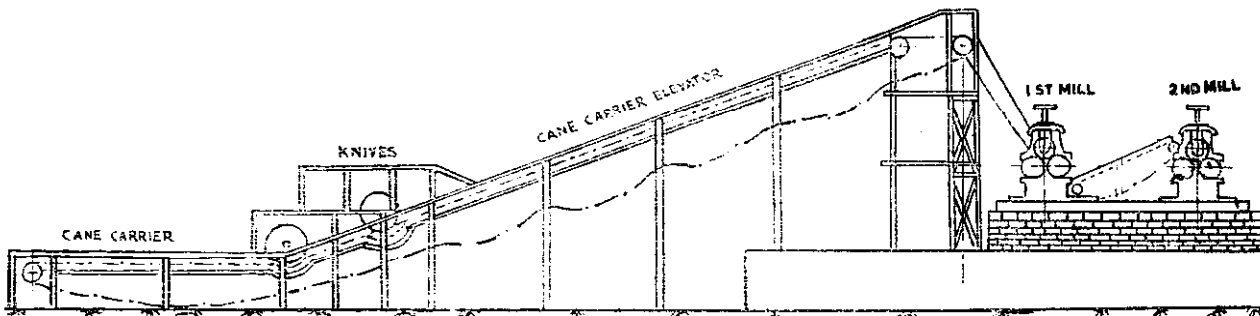

FIG. 5

6 ROLLER HYDRAULIC CRUSHER DEVELOPED BY P.R.A.I. IN COLLABORATION WITH N.S.I. FOR MINI SUGAR MILLS. MILLING EFFICIENCY 80%

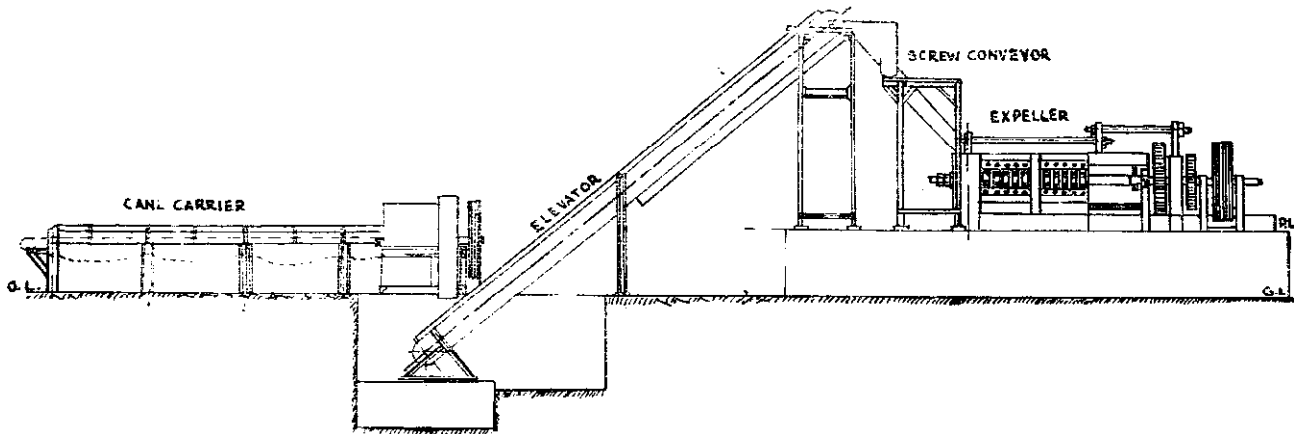

FIG. 6

A NEW TYPE OF CRUSHING DEVICE, BASED ON EXTRUSION PRINCIPLE BEING DEVELOPED BY P.R.A.I. FOR ACHIEVING A MILLING EFFICIENCY OF 90% IN MINI SUGAR TECHNOLOGY.

PLATE XXII A



Deola Plant

FIG. 7

GREEN LOWER PORTION OF THE STEM AND PART OF THE ROOTS ARE WELL SOAKED IN WATER. AFTER HAND RUBBING THICK SOLUTION OR COAGULANT IS OBTAINED

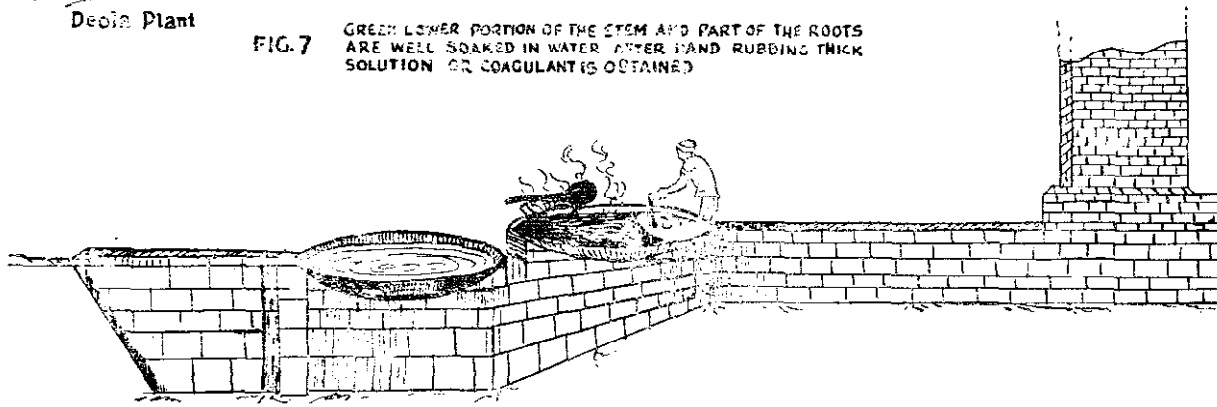

THE COAGULANT IS ADDED TO THE JUICE JUST ABOUT TO BOIL. THICK FOAM IS OBTAINED, WHICH IS REMOVED BY A PERFORATED IRON SHEET ATTACHED TO A HANDLE. CLEAR JUICE IS THEN CONCENTRATED

FIG. 8

PLATE XXII C

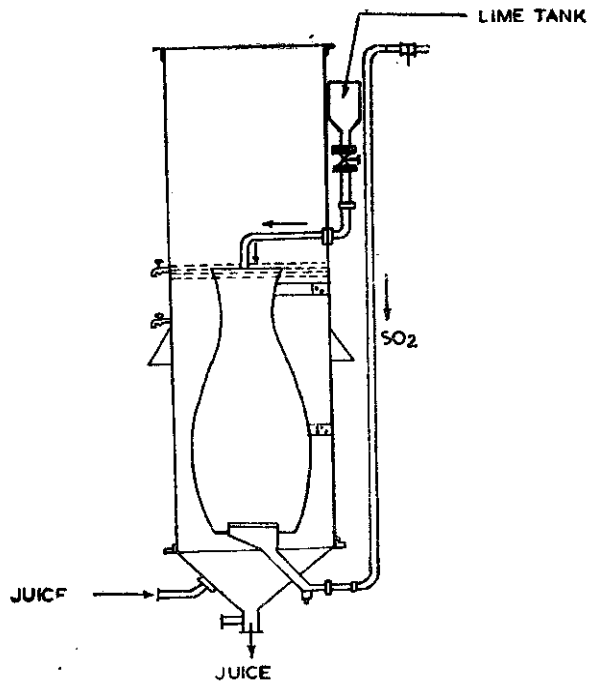

LATEST SULPHITATION TANK DEVELOPED FOR MINI SUGAR TECHNOLOGY.

CLARIFICATION TECHNIQUE

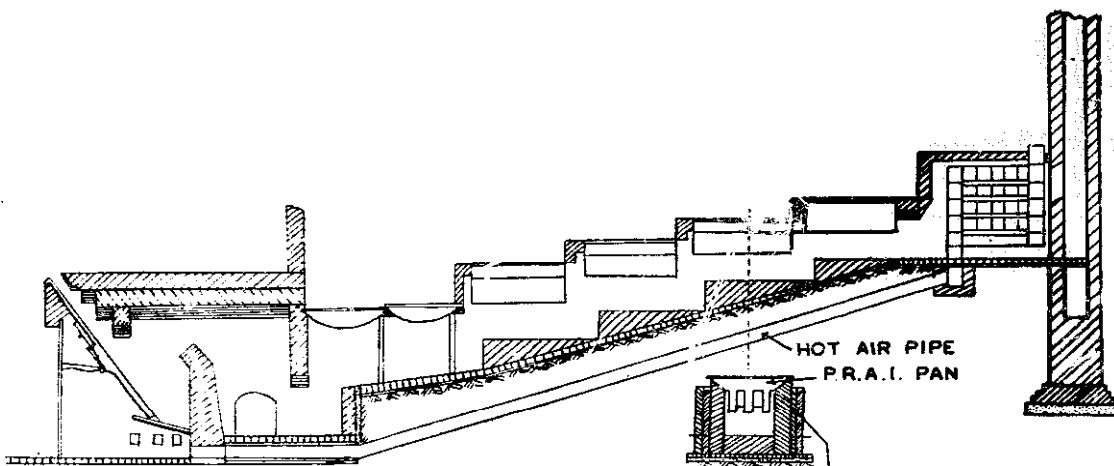

P.R.A TYPE COMBUSTION CHAMBER BEL NOW BEING USED IN MINI SUGAR TECHNOLOGY WITH COMPLETE RECOVERATING DEVICE.

HOT AIR PIPE
P.R.A.I. PAN
ASH FILLING
ASH BED
HOT AIR PIPE

EVAPORATION - CONCENTRATION TECHNIQUE

PLATE XXII D

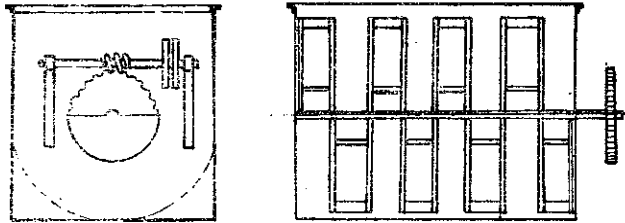

FIG. 2

CRYSTALLIZATION IN MOTION AS USED IN MINI SUGAR TECHNOLOGY

CRYSTALLIZATION TECHNIQUES

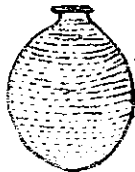

FIG. 1
STATIC CRYSTALLISER
USED IN OLD KHARSAARI
INDUSTRY.
HAS FILLED IN EARTHEN POT

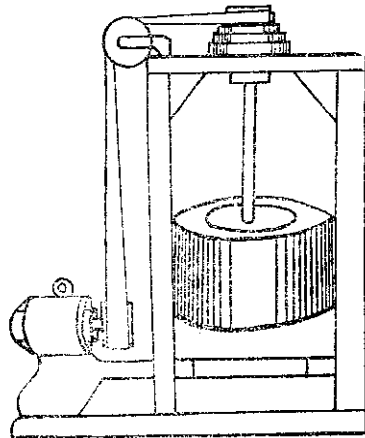

FIG. 3

CENTRIFUGAL USED IN MINI SUGAR TECHNOLOGY

SEPARATION OF CRYSTALS FROM MOLASSES

SEPARATION OF CRYSTALS FROM MOLASSES

INDIGENOUS KHANDSARI SYSTEM

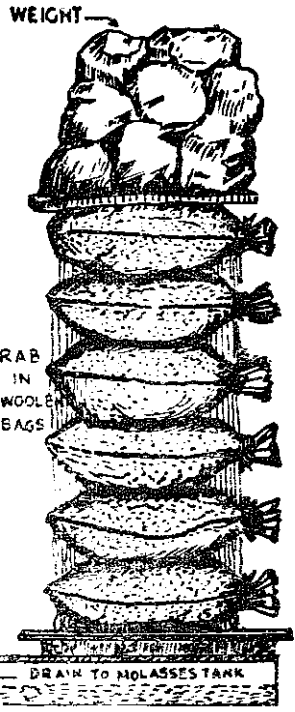

FIG. 9

PART OF THE MOLASSES IS DRAWN OUT BY PRESSURE

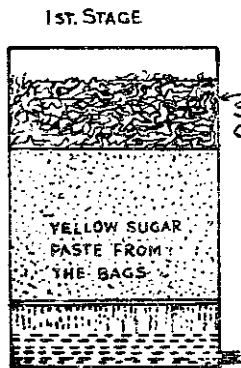

FIG. 10

MASSICUTE AFTER PARTLY REMOVING OF MOLASSES IS FILLED IN A TANK & OVER WHICH SEWAR GRASS IS PUT

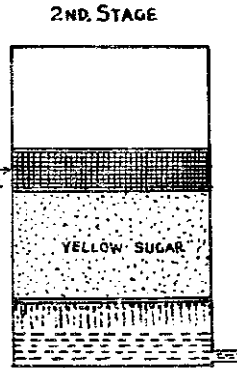

FIG. 11

SHOWING THE UPPER LAYOR OF THE SUGAR FREED FROM MOLASSES

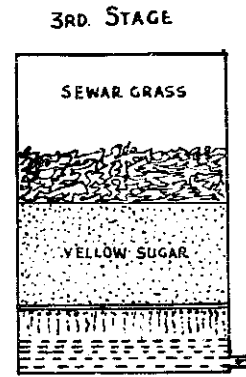

FIG. 12

PROCESS IS REPEATD

PLATE XXII F

SUGARCANE CRUSHER

(Figures relate to Plate XXIII)

Introduction : The crop of sugarcane is usually crushed by large sugar mills, small-scale crystal sugar manufacturing plants, khandsari sugar and gur-making establishments. Even then, some portion of the crop is left unused. A portion of the cane crop is brought to the town and sold for chewing, making sugarcane candies and extracting juice. One of the familiar sights in the cities and towns is the extraction of sugarcane juice by a hand operated cane crusher making a delicious juice with spices and lemon to serve as a refreshing drink. This provides an avenue of employment to some persons and a refreshing drink to the tourists and the local people.

Construction : The equipment consists of two rollers between which the canes are inserted and crushed after passing several times. At one end, screw type threads are provided in the rollers which crush the cane initially. Once it has been pressed flat, it is passed through the other portion of the rollers, each time the distance between the rollers is reduced making adjustments of the screw from the top.

One large pulley 120 cm. dia. with handle provided at one end is the prime mover, which drives a small pinion of 10 cm. dia. mounted on the same axis. The small pinion meshes with a large gear of 60 cm. dia. which drives the lower roller. A smaller pinion of 8 cm. dia. mounted on the same axle meshes with another pinion of equal size on whose axis the top roller is mounted. Thus the two rollers move in opposite directions. Underneath the roller, a juice collecting device is fitted. All the falling juice drains into a hole, under which a tumbler, a lota or a flask is kept for collection.

How to operate : One or two sugarcanes, nicely cleaned of leaves, knots and soft and rotten portions, are fed at one end of the rollers where thread like formation is made and the handle is rotated. The sugarcanes come out from the other end, squeezed of a large portion of their juice and pressed flat. The cane thus pressed is then fed between the flatter portion of the roller. Some juice comes out at every feeding. The upper screws are then rotated and the distance between the roller progressively reduced. This process is continued until maximum possible juice is extracted. The bagasse can be sold as cattle feed or fuel. It is also used for making paper.

Price: Rs. 1,000

It is available from many machinery manufacturers.

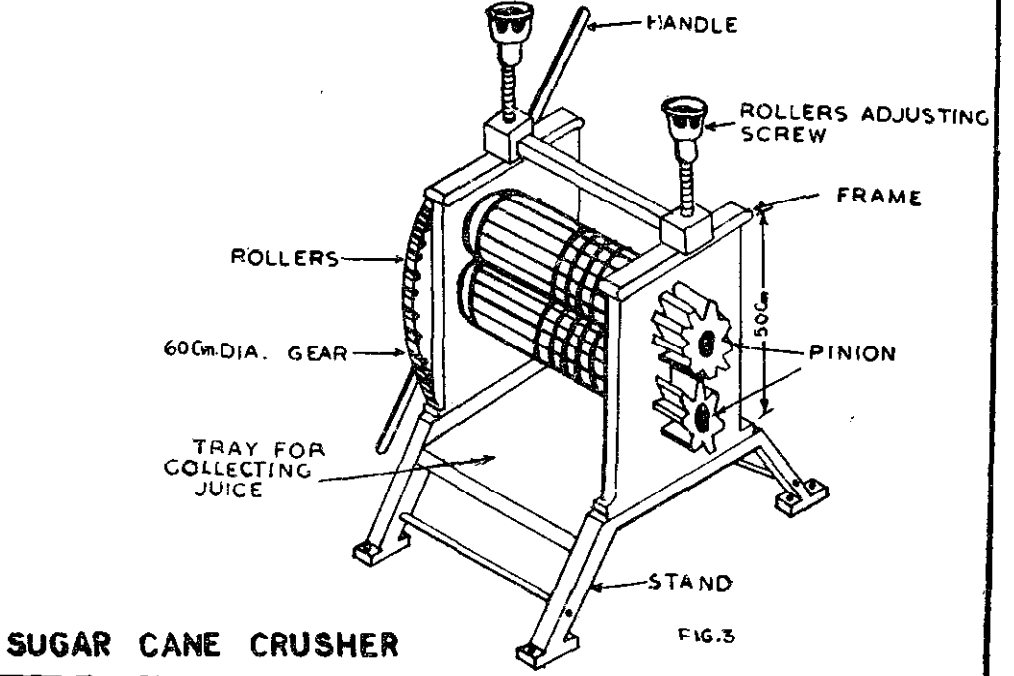
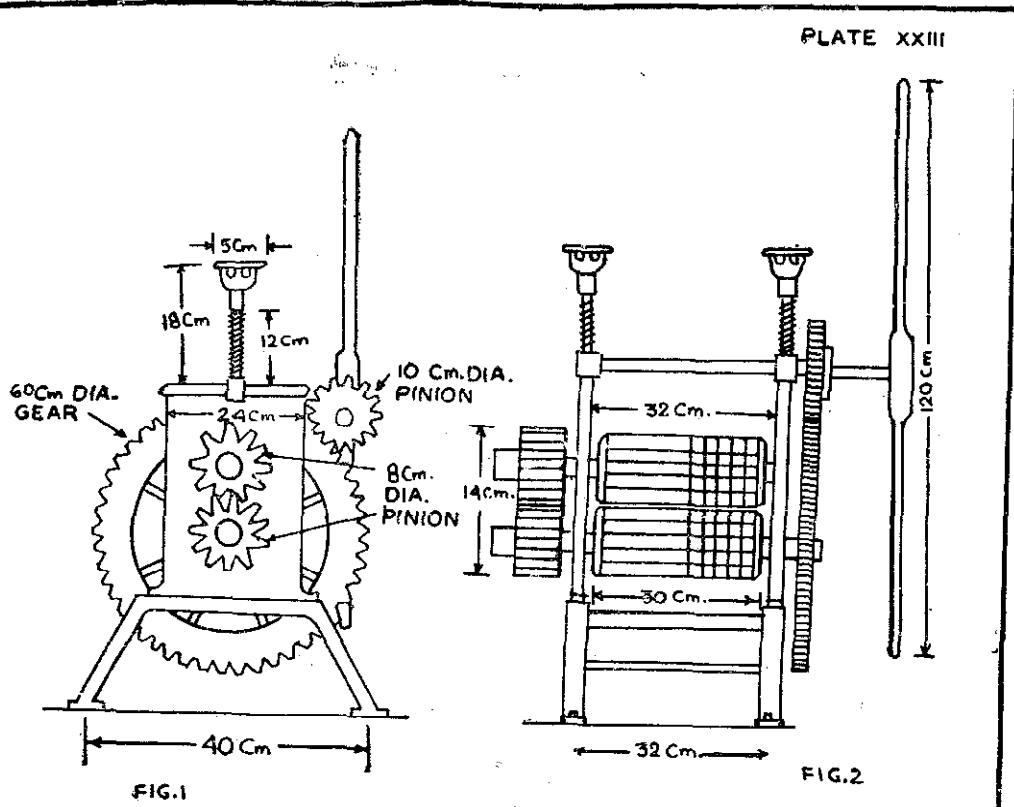

SUGAR CANE CRUSHER

FIG. 3

Village and Cottage Industries

INTRODUCTION

The village and cottage industries depending upon the primitive and indigenous methods of manufacture are decaying rapidly. This is mainly due to the competition from the urban industries which are using better technology and mechanised power. The technologies being used in the village industries like pottery, metal work, oil extraction, tanning of hides and skins, weaving, carpet making, and other handicrafts, etc. have not received the attention of our scientists and technologists for their improvement. Most of the new methods and technologies have been developed in the western industrialised countries in widely different situations. They have been imported and industries have been set up in the urban areas of the developing countries giving serious setbacks to village industries. A modern western technology usually needs a high capital investment for creating a workplace. It is impossible, with the help of this expensive technology, to set up a large number of workplaces in the rural areas, because the developing countries cannot afford to find such resources. The result is that employment is generated only in a few urban centres and enclaves and the vast rural population is left high and dry. The existing industries and crafts are decaying and withering away due to competition with the urban industries.

There is, therefore, a great need for reviving the technology of the village and cottage industries and injecting into them a new life based on modern scientific methods including technology, products selection, and design, as well as appropriate economics, management, and marketing.

There can be three methods to achieve this objective :

- (1) upgrading the basic village technologies,
- (2) de-scaling large industries for the manufacture of commodities like sugar, cement and paper,
- (3) developing new technology or processes, keeping in mind that the cost should be fairly low for creating workplaces so that they could be widely adopted under the village conditions.

In this section, we have tried to include some industries which can be set up in villages with small capital, new technology and new management methods, and can employ a number of under-employed and unemployed people in the villages. Efforts are being made to collect information on a number of other industries. In addition to reviving the ancient village industries, new economic activities should also be added.

RED CLAY POTTERY

(*Figures relate to Plate XXIV*)

Contact Agency—Khadi and Village Industries Commission, Irla Road, Vileparle, Bombay-56.

Introduction : White clay is expensive and is not readily available. Moreover, for the preparation of other ingredients, expensive plant and equipment are required. Red clay is mostly available in plenty in the rural areas and has for long been the main raw material for traditional pottery articles like pots, pans, bowls, pitchers, etc. In addition to these, two new items, mangalore tiles and burnt clay pipes are manufactured from red clay which find a ready market. The mangalore tiles are used for roofing. They are superior to traditional tiles and their coverage area is almost 8 times that of the traditional tiles. There is saving in time in roofing as well as in cost for although one thousand mangalore tiles cost Rs. 350, while one thousand traditional tiles cost Rs. 70/-, the former have larger size, and economy takes place in the overall cost.

Preparation of mangalore tiles

Pug Mill : Red clay is dug out of a pit and cleaned of hard material like stones or brickbats and washed to get rid of impurities like lime stone. The powdered clay is then put in a pug mill which mixes the clay very well. One pug mill can supply raw material to many potters. If pug mill cannot be purchased, leg pugging can be carried out and the clay can be prepared for making tiles.

Fly press : The pugged clay is then pressed in a fly press for making mangalore tiles. The fly press can be bought from any manufacturer. The moulds and the die of any size can also be fabricated in any engineering workshop.

When the tiles are cast in a press, they are kept on a wooden frame and dried in a closed room and then fired in kiln.

Burnt clay pipe : Burnt clay pipes are being used these days for irrigation purposes. They are much cheaper than concrete spun pipes. Sophisticated machinery is not required for the manufacture of pipes. Red clay taken out from pug mill is rolled into flats in a frame, the width being equal to the circumference of the pipe. The flat clay is then rolled on to the wooden mould kept on a wooden platform and pressed from all sides by a tool meant for the purpose, so that the clay takes the shape of the mould. The ends are then joined by soft clay and the mould is taken out. The moulded pipe is allowed to dry on the wooden platform in the same manner as the mangalore tiles. It is then fired in the kiln.

Burnt clay pipes have been tried at many places for irrigation work and have proved very strong, durable and reliable.

Cost economics : The scheme is given in two phases employing 14 to 25 persons. At the end of the first phase, i.e. a period of one year, 750 tiles could be pressed per day. During the second phase, i.e. at the end of second year, the production capacity will increase to 1500 tiles per day. With the same equipment at the end of the third and fourth year, production can be further

increased to 2000 and 2400 tiles respectively. The manufacture of burnt clay pipe can be carried on simultaneously with that of mangalore tiles by employing a few extra workers.

<i>Particulars</i>	<i>Ist phase</i>	<i>2nd phase</i>	<i>Total</i>
	Rs.	Rs.	Rs.
1. Land 1 acre	5,000	..	5,000 (can also be hired)
2. Building (2,500 sq. ft.) including 300 sq. ft. concrete floor ..	15,000	10,000	25,000 (can also be hired)
3. Tile press	4,000	1,000	5,000
4. Horizontal pug mill	10,000	..	10,000
5. Cutting tables	500	..	500
6. Drying racks	10,000	10,000	20,000
7. Kiln	15,000	10,000	25,000
8. Disintegrator	2,500	..	2,500
9. Installation charges and contingencies	3,000	..	3,000
10. Water charges	2,500	1,500	4,000
Total ..	67,500	32,500	1,00,000

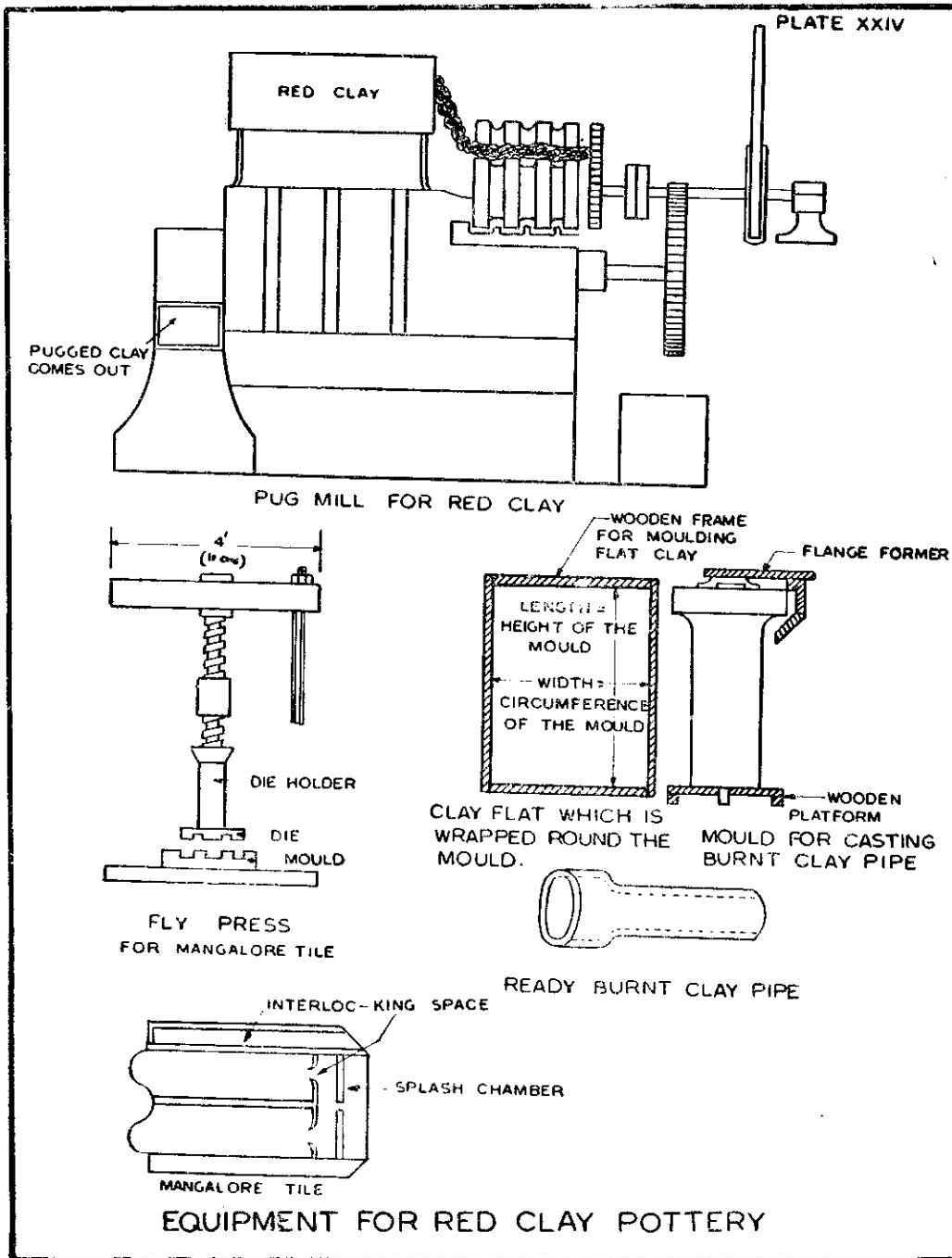

DECENTRALISED CERAMIC UNIT

(*Figures relate to Plates XXV, XXVA, XXVI, and XXVIA*)

Contact Agency : Planning, Research and Action Divn., Kala Kankar House, Lucknow.

Introduction: The number of potters producing ordinary earthen wares and pottery vessels and utensils may be about 2 million in the country. It is necessary that the hereditary skill of these potters is utilised for the manufacture of better class of articles using improved technological processes, which will not only give the consumer a better value for his money in the form of cheap price and better quality and variety of products, but also better earning to the village potters who are living below subsistence level at present.

The decentralised ceramic unit scheme prepared by the Planning, Research and Action Divn. is a step in this direction. It is hoped that if the projects are set up and managed imaginatively, they will improve the condition of the village potters by providing them an opportunity to improve their skills, to adopt new technological processes and to be able to use modern business methods and economic scale for their products. This will bring the advantage of decentralised production in their homes, thus avoiding the need of seasonal migration to towns and cities with consequent problems of slums and overcrowding and extreme pressure on the civic amenities.

Project and scheme : The main feature of the scheme is that (i) a service centre is owned and run by the central organisational agency, government or others. The service centre shall have the following functions :

- (a) Providing facilities for buildings and kilns in the cottage workshops.
- (b) Supply of semi-processed raw material, especially body, glaze, colours, plaster of Paris and other miscellaneous articles.
- (c) Providing technical know-how and assistance in designing, shaping, colouring, firing, etc.
- (d) Organising centralised marketing of goods manufactured by cottage workshops.

(ii) Cottage workshops, owned by a family of artisans or other entrepreneurs willing to take up the work.

The service centre will also be equipped with one prototype cottage workshop, which shall be used for the purpose of developing new products, like sanitary wares, electrical goods, porcelain, new designs of tablewares, decoration articles, and can also serve as a training ground for new entrepreneurs and workers.

Before sanctioning the establishment of a workshop to an individual, training facilities would be provided to him for a period of four months in new methods, use of new technology and new business methods.

The cottage workshop could be set up in houses owned by the entrepreneurs. All these workshops would buy semi-processed raw materials from the centre, manufacture the articles and bake them in the kilns owned by the centre and then sell them through the service centres. Each workshop would require 6-10 persons to man it. These workshops would be fully equipped with the PRAI type kiln, production equipment and 2 H.P. motor. In case, electricity

is not available, the foot operated machine could be utilised. Ten such workshops could be built up around one service centre having a kiln and one-ton slip house.

Materials used

- I. Body—china clay, quartz and felspar marble chips.
- II. Glaze—borax, boric acid, white lead, red lead, barium carbonate, zinc oxide, soda ash, aluminium.
- III. Colour and dye—cobalt oxide, chromium oxide, iron oxide, manganese oxide, nickel oxide, potassium bichromate, antimony oxide, tin oxide, etc.
- IV. Mould—plaster of Paris.
- V. Sagger box—fire clay.
- VI. Fuel—steam coal.

Buildings and shed : (i) Machinery shed 900 sq. ft. (ii) Storage shed 700 sq. ft. (iii) Office 300 sq. ft.

Machinery : (i) $4\frac{1}{2}' \times 4\frac{1}{2}'$ size ball mills $\frac{1}{2}$ ton capacity.

(ii) $2' \times 2'$ ball mill for glaze loading 22 kg.

(iii) A pot mill frame of six pots is adequate for one ton slip house. Two such frames for 2-ton capacity slip house would be required. The grinding of the stones is done in the ball mills and the blunging the clay in blungers followed by mixing both the portions in a mixing arc. Thereafter, the body is filtered through the filter presses and filter cakes obtained to be used for manufacturing the articles.

(iv) Pug mill is an equipment which is needed when most of the shaping is to be done by jigger jolly, but an alternative method of pugging by feet is also possible for small units. In a small slip house, its inclusion may be considered on the availability of funds.

(v) Vibrating screen may be worked by hand.

(vi) Jaw crusher is used for breaking stones. It may be broken manually by hammers as well.

(vii) A disintegrator may be used for grinding fire-clay and broken saggars for making new and usable saggars.

Cost economics—one-ton capacity slip house and service centre, machinery and equipment

<i>Machinery requirement</i>	<i>No.</i>	<i>Price Rs.</i>	
1. Ball mill $2\frac{1}{2}' \times 2'$	1	5,000	
2. Pot mill 6 pots	1	700	
3. Blunger	1	2,200	
4. Mixing arc	1	1,500	
5. Diaphragm pump	1	7,000	
6. Filter press $18'' \times 18''$	1	9,000	
7. Vibrating screen	1	2,000	
8. Kiln for calcining quartz.. ..	1	3,000	
9. Frit furnace	1	2,200	
10. Motor 10 H.P.	1	7,000	
11. Stores and contingencies		4,000	
			(43,600)
<i>Working capital</i>		20,000	

<i>Raw Material</i>	<i>Price Rs.</i>
Quartz 10 tons	1,000
Felspar 6 tons	600
China clay 14 tons	7,000
Glaze material 1.5 tons	3,000
Plaster of Paris 10 tons	600
Saggar clay 5.0 tons	600
Coal 65.0 tons	12,000
	<hr/>
	24,800
 <i>Labour :</i>	
Workers 10 at Rs. 150 per month	1,500
 <i>Power</i>	
1000 units at p. 10/unit per month	180
 <i>Overhead</i>	
Managerial and technical staff per month	1,000
Contingencies per month	500
	<hr/>
	3,180 per month.
 <i>Income :</i>	
Sale of body at Rs. 500/- per ton for 30 tons	1,500
Glaze at Rs. 4,000 per ton for 1.5 tons	6,000
Saggar material at Rs. 150 per ton for 5 tons	750
Plaster of Paris at Rs. 700 per ton for 1 ton	700
	<hr/>
	8,450
 Monthly gross profit (8,450—3,180)—5,270	
 <i>Depreciation and other expenses :</i>	
Machinery at 10 %	4,360
Building 5%	1,500
Maintenance and repairs at 2%	1,400
Interest on working capital 11%	2,200
	<hr/>
	9,460
 Monthly= 800 p.m. (Approx.)	
Net monthly profit=(5,270—800)=Rs. 4,470	
The following essential machinery and equipment would be required for the cottage workshop :	
1. Kiln	10,000
2. Jigger jolly with motor-2	4,500
3. Moulds	1,500
4. Saggars	500
	<hr/>
Total	16,500

Khadi and Village Industries Commission encourages setting up of ceramic plants. Details may be obtained from them.

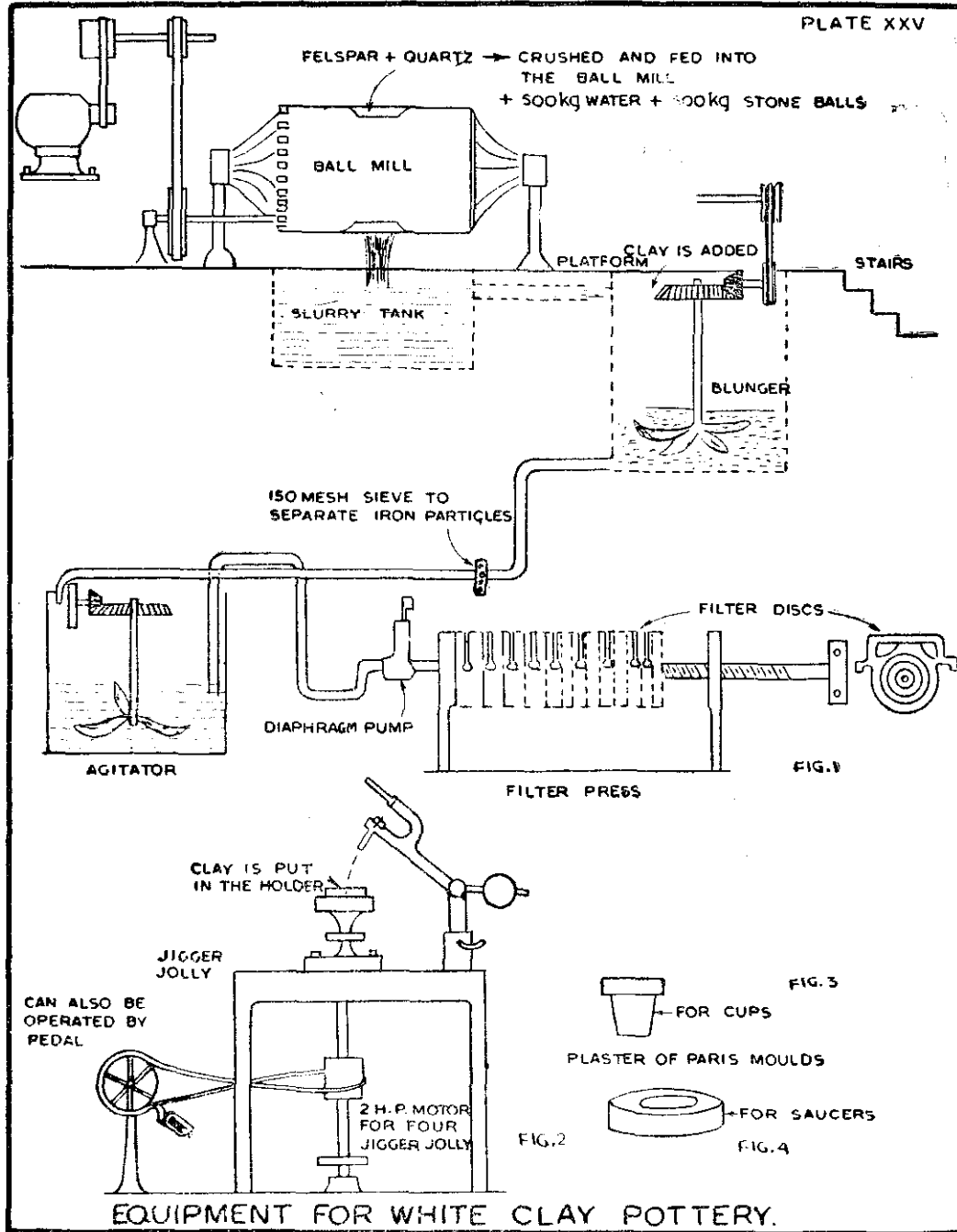

PLATE XXV A



FIG. 1

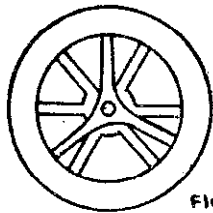
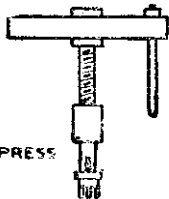

FIG. 2

TRADITIONAL POTTER'S WHEEL



FLY PRESS

FIG. 3

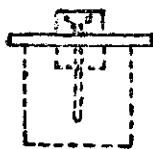

MOULD FOR MUG HANDLES.

FIG. 4

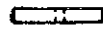

JOINING HANDLE WITH FIG. 6 SLIP

FIG. 5

MOULD FOR MUGS

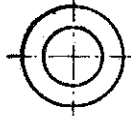

FIG. 8

DIE FOR BULB HOLDER INSULATOR.

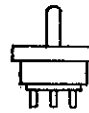

FIG. 7

FIG. 9

DIE HOLDER



FIG. 10

MOULD FOR BULB HOLDER INSULATOR



SEPARATE PART IN MOULD. CAN GO UP AND DOWN FOR RELEASING THE CAST MATERIAL.

FIG. 11



FIG. 12

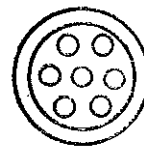
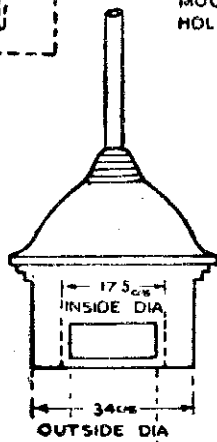

FIG. 13

SAGGAR MADE OF FIRE BRICKS FOR KEEPING MATERIAL INSIDE FURNACE FOR FIRING.



INSIDE DIA

OUTSIDE DIA

FURNACE

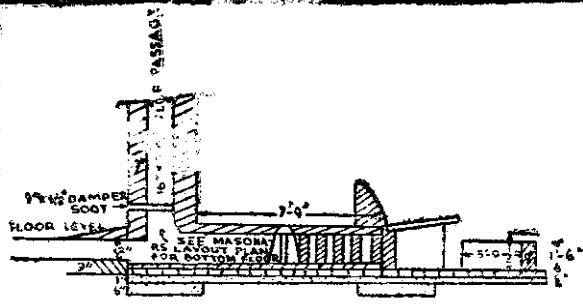

SECTION ON A-A UPTO FLOOR

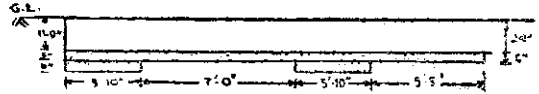

SECTION ON A-A EARTH WORK & LIME CONCRETE IN FOUNDATION

SCALE 1/2" = 1'-0"

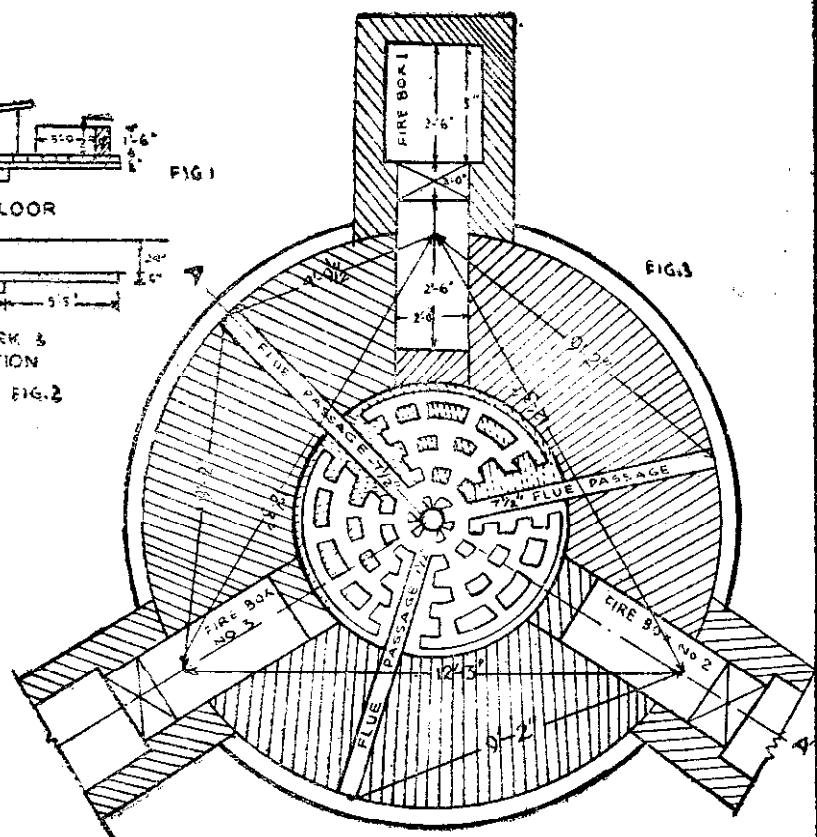

PLAN OF POTTERY KILN

SCALE 1/2" = 3'

PLATE XXVI

PLATE XXVI
A

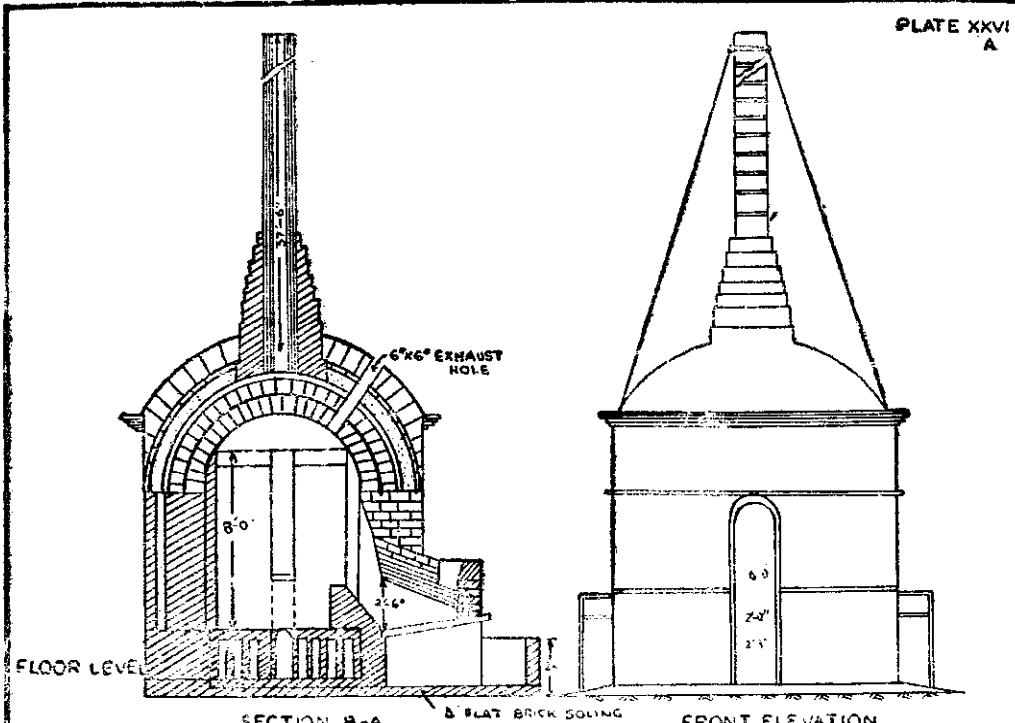

FIG. 2

SECTION B-A

6" PLAT BRICK SOLING

FRONT ELEVATION

FIG. 3

SCALE 1"=6'

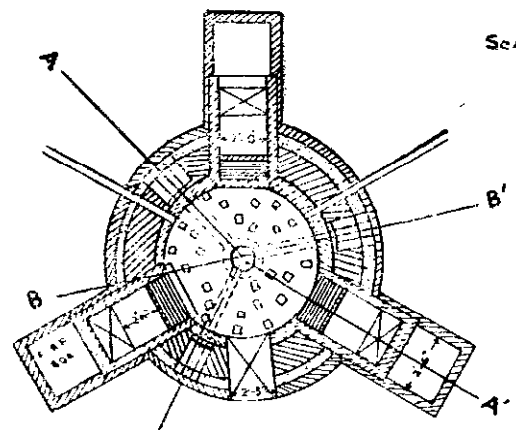

FIG. 1

FLOOR PLAN

POTTERY KILN

LIME KILN

(*Figures relate to Plate XXVII*)

Contact Agency—Khadi and Village Industries Commission, Irla Road, Vile Parle, Bombay-56.

Introduction : The kiln is used for manufacturing lime, an important construction material. The raw material—limestone, dolomite or chalk—is heated in the vertical kiln under controlled calcination conditions. The carbonates decompose, producing quick lime. If it is further heated at a high temperature the quick lime is said to be dead burned and not so reactive.

Construction of the improved lime kiln: Khadi and Village Industries Commission have designed an improved lime kiln which gives higher output. The design and dimensions are given in the figure.

The kiln is of 1.5 tonne capacity but the capacity can be increased upto 2 tonnes per day of 12 hour working.

The materials required for construction are : (i) well fired red bricks 9,000; (ii) rubble and metal for foundation; (iii) refractory bricks—600; (iv) fire clay—300 kg., (v) lime mortar—250 cft.

The kiln consists of a suitable foundation, which is laid upto the ground level using rubble, metal, and lime mortar. A strong basement over the foundation consisting of the plinth is constructed of red bricks or stones. A discharging slope is constructed over the plinth. The highest point of the slope or the apex is 30 cm. from the centre of the plinth. There are four discharging holes for the removal of lime and for entry of air.

Fire brick lining of 220 cm. is advisable starting from the 120th cm. from ground level. It saves fuel consumption and is also economical in the long run.

The insulating ring may be left blank as air is a good insulator. In this case the lining and the outer wall are joined through the insulation gap by fixing 6 bricks at equal distances over each layer. These bricks are called 'key-bricks.' Alternatively the insulation ring may be filled with (i) red brick powder, slaked lime, and ash mixed in equal proportions, or (ii) burnt paddy husk.

The triangular spaces resulting due to laying of the fire bricks are filled with lime mortar added with fire clay. The corners of the bricks are kept intact. The lining should be constructed of thin and firm joints, using fire-clay lime mortar, avoiding gaps and small crevices.

The outer wall of the kiln is constructed in red bricks, using interlocking bricks. The outside and inside of the lining may be plastered with a mixture of cowdung and clay. The top surface of the kiln is also to be well plastered.

Suitable band strips, 4 in number, with screw arrangement are fitted around the kiln at equal distances to strengthen and reinforce it.

The kiln has 6 poke holes, three on each side.

Brick staircase to go up the kiln is recommended.

A movable G.I. sheet chimney as shown in the diagram is fired.

The kiln should be thoroughly dried before firing, and should be allowed to attain maximum temperature.

Main features : The main features of this design are :

- a. Conical shape at the bottom for proper discharge of lime and also for proper draft control.
- b. One insulation is kept, that too only for a restricted height.
- c. A fire brick lining at least in the hottest zone of the kiln is recommended.
- d. Three poke holes on either side of the kiln are found more useful.
- e. A chimney in single piece is necessary.

Cost economics : For one month at the rate of 2 tonnes per day and 25 working days in a month.

<i>Raw Materials :</i>		Rs. P.
1. Lime stone: 50 tonnes at Rs. 14 per tonne		700.00
2. Fuel—coke 6 tonnes at Rs. 100 per tonne		600.00
3. Labour charge for 6 workers (3 males and 3 females) for conversion of limestone into lime, sizing, charging, discharging, slaking, and sieving.		900.00
4. Miscellaneous :		
(i) Rent for premises including lease		140.00
(ii) Depreciation at 10%		180.00
(iii) Overhead and supervising		184.00
	Total Rs. ..	2704.00
Income : 42 tonnes of lime		
(i) Cost of production per tonne of lime ..		55.00
(ii) Income from sale of lime at Rs. 90 per tonne ..		3780.00
(iii) Net profit for a month=Rs. 3780—2704 ..		1076.00

PLATE XXVII

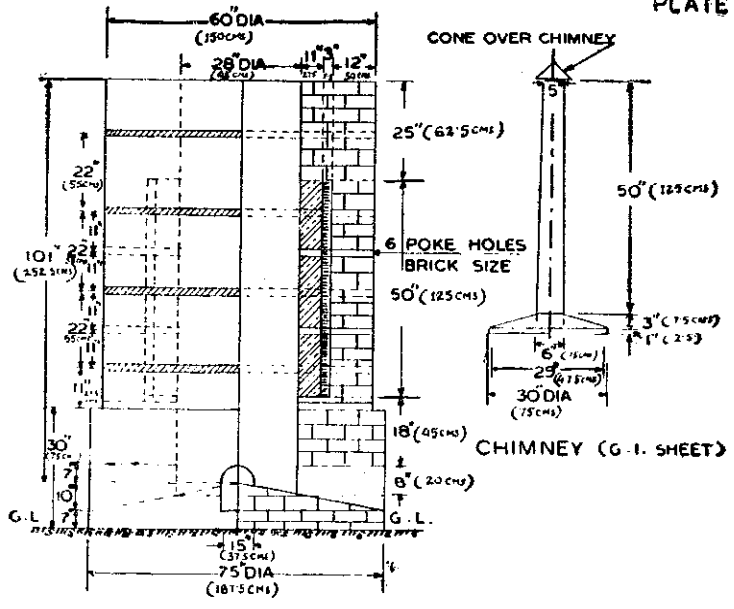

ELEVATION

-  FIRE BRICKS
-  RED BRICKS
-  INSULATION
-  M. S. STRIP 1/8" x 2"

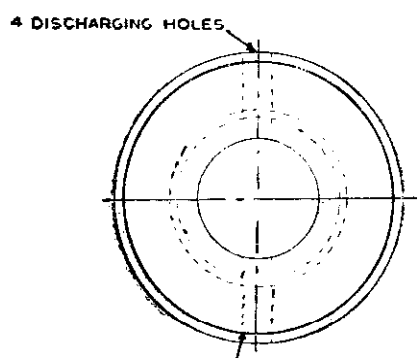

4 METAL BANDS WITH BOLT AND SHACKLE ARRANGEMENT

PLAN

LIME KILN

SINGLE-SPINDLE CHARKHA*

(Figures relate to Plate XXVIII)

Contact Agency : Khadi and Village Industries Commission, Irla Road, Vile Parle, Bombay-56.

Introduction : The importance of charkha is still great and many persons like to spin in their leisure hours. The kisan 'charkha' and 'Amber' charkha are not so efficient. The single-spindle charkha is an improved version of them and makes the spinning much easier. Also, based on this new design, a six-spindle charkha has been produced which gives livelihood to many wage earners.

Construction : The charkha is made of metal; the gears and pinions are of synthetic materials and the cover is of wood. The length is 23 cms., width 13 cms., height 28 cms. It weighs only 2.5 kg. together with the cover, and 1.6 kg. without cover. It cannot be manufactured everywhere, because it requires intricate and precision casting and machining.

One can spin 500 meters of yarn in one hour with this 3 roller charkha. It makes the thread nineteen times finer and has 6.25 inches throw. The yarns after spinning can be wound on a winder to make hanks.

It is a portable equipment and easy to operate.

How operated : The 'charkha' must be cleaned every day before operation, and lubrication should be done at least once a week in all the bushes and bearings. The rubber rollers should be adjusted once and should not be tampered with frequently. The thread should neither be too loose nor too tight. The handle must be rotated slowly and uniformly in clock-wise direction but the thread should be in the opposite side. The bobbins should be fitted in such a way that there should be no thread on the top and bottom up to half an inch. The winder on which the spun yarn is wound, should be fixed on the opposite side of the handle.

One end of the roving should be passed through the catchroller. When the end of the roving comes out, it should be fixed with the thread on the bobbin, passing it through the yarn ring and the traveller, and the handle should be rotated. Five hooks are provided at the bottom. The thread should be wrapped on the reel through each hook for 200 rounds after which the indicator revolving on the threaded shaft comes out and falls down. After that, the thread is inserted through the next hook, and thus hanks of 200 rounds are made on the winder.

The principle of single-spindle charkha has been further extended. Four spindle- and six spindle- charkha have also been designed, which are very useful.

Price : Rs. 50.

*Spinning wheel

PLATE XXVIII

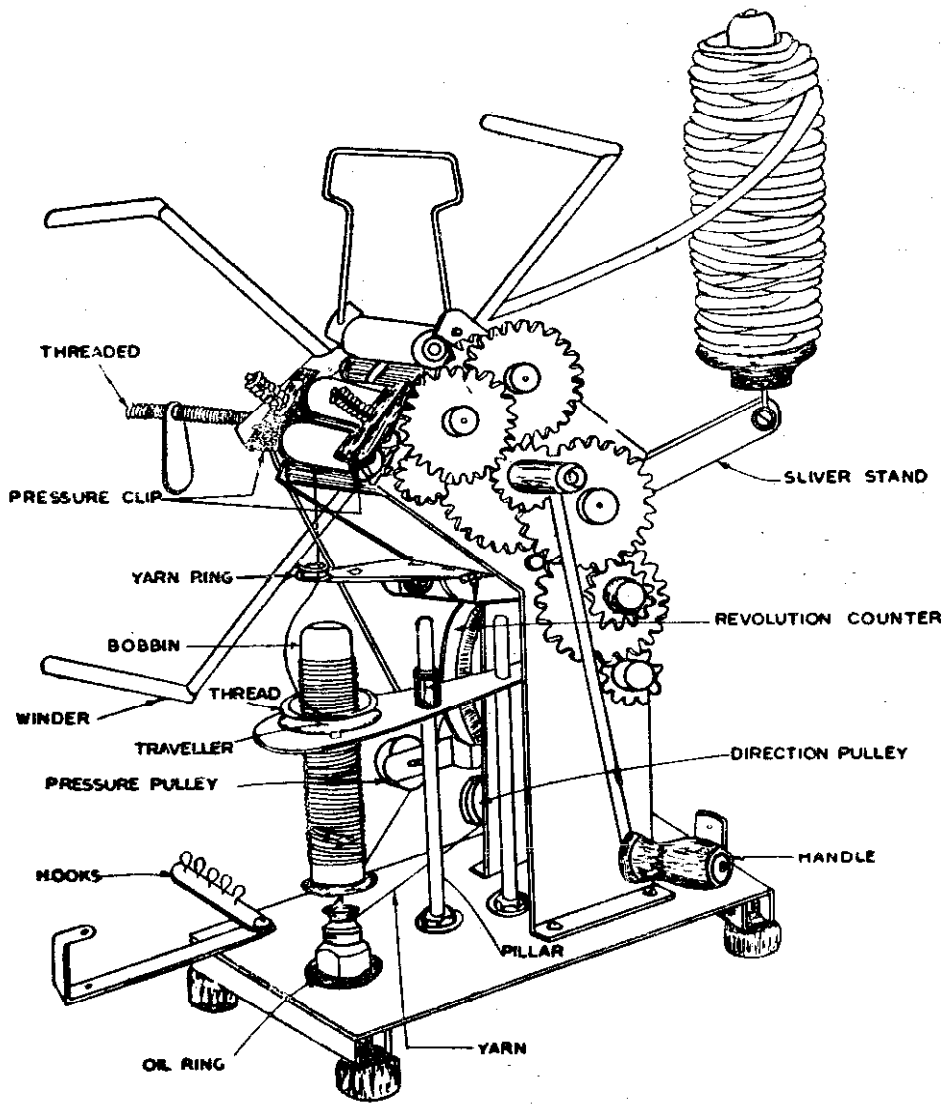

SINGLE - SPINDLE CHARKHA.

MATCHES MAKING

(Figures relate to Plate XXIX, XXIXA)

Contact Agency: Khadi and Village Industries Commission, Irla Road,
Vileparle, Bombay-56.

Introduction : Matches are one of the most indispensable items of every day use in every household rich or poor alike and categorised among essential items.

Method of manufacture: If the supplies of veneer, splints, labels, etc. for box making and sticks are handled from a central point, preferably a district, the following processes can be carried out in villages :

- (i) *Frame filling* : The splints are filled in plates and the plates are then arranged in a frame and fixed by bolts. There are 2500 splints in one frame (50 splints in each plate and 50 plates in each frame).
- (ii) *Paraffining*: Paraffin wax is melted in a tray heated by a stove underneath. The frame is dipped in the tray and taken out immediately.
- (iii) *Tip dipping*: Ingredients of tip composition are given in Table 1. The frame is dipped in the tray in which the tip ingredients are prepared and kept. Boiling water is poured into the tray space to keep the ingredients in fluid state.
- (iv) *Side painting*: A frame is filled with the outer cover of the match boxes and the sides are painted with friction surface composition as given in Table 2.
- (v) *Packing and labelling*: 50 match sticks are filled in each box and the boxes labelled with printed labels or printed advertisements.

TABLE 1
Tip Composition

<i>Serial No.</i>	<i>Particulars</i>				<i>Quantity required for 25 gross of 50's</i>
1.	Potassium chlorate	1.570 kg.
2.	Glue	5.350 kg.
3.	Potash bichromate	0.030 kg.
4.	Rosin	0.030 kg.
5.	Iron oxide	0.680 kg.
6.	Manganese dioxide	0.340 kg.
7.	Glass powder	0.375 kg.
8.	Sulphur	0.110 kg.
9.	Water	540 oz.

TABLE 2
Friction Surface Composition

<i>Serial No.</i>	<i>Particulars</i>	<i>Quantity required for 25 gross of 50's</i>
1.	Glue	0.042 kg.
2.	Potassium bichromate .. .	0.005 kg.
3.	Glass powder	0.042 kg.
4.	Antimony sulphide	0.040 kg.
5.	Red phosphorus	0.180 kg.
6.	Water	31 oz.

TABLE 3
Cost of raw materials for one year's working of 200 days at the rate of 50 gross production of 50's in one day.

<i>Sl. No.</i>	<i>Particulars</i>	<i>Quantity</i>	<i>Price in Rs.</i>
1.	Glue	160 kg.	1000.00
2.	Manganese dioxide	400 kg.	400.00
3.	Glass powder	200 kg.	60.00
4.	Iron oxide	200 kg.	120.00
5.	Sulphur	200 kg.	165.00
6.	Potassium chlorate	700 kg.	2450.00
7.	Potassium bichromate	12 kg.	55.00
8.	Rosin	12 kg.	42.00
9.	Red phosphorous	60 kg.	825.00
10.	Antimony sulphide	12 kg.	60.00
11.	Dye	8 kg.	60.00
12.	Paraffin wax	1400 kg. (5 drums)	1650.00
13.	Tapioca starch	300 kg.	450.00
14.	Splints	5000 kg.	5000.00
15.	Vencers	8000 gross	4800.00
16.	Blue paper	100 reams	2700.00
17.	Craft paper for packing	12 reams	
18.	Asian craft paper	20 rolls	440.00
19.	Labels	*1.2 million in number	1200.00
			21477.00
	Say		22000.00

*This could also be supplied free of cost by advertising companies or by Khadi and Village Industries Commission.

No. of workers employed: 50 workers for 50 gross per day.

PLATE XXIX



FIG. 1

MEASURING GLASS



FIG. 2

SIEVE



FIG. 3

MORTAR & PESTLE



FIG. 4

BRUSH

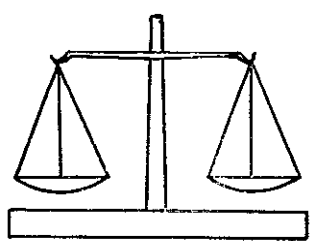

FIG. 5

BALANCE



FIG. 6

WEIGHTS



FIG. 7

THERMOMETER



FIG. 8

GLASS JARS

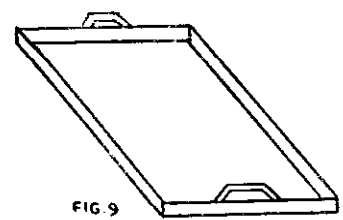

FIG. 9

TRAY

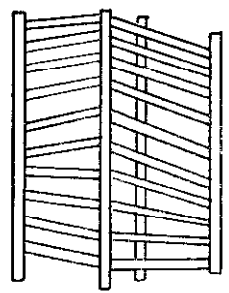
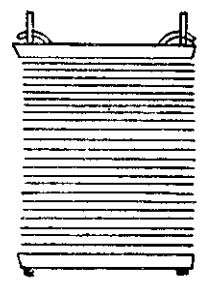

FIG. 10 RACK



MATCH FRAME
FIG. 11

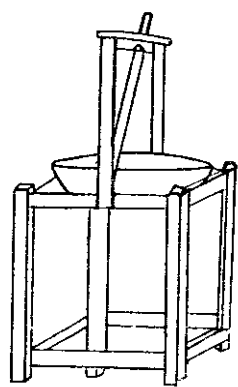

FIG. 12

GRINDER

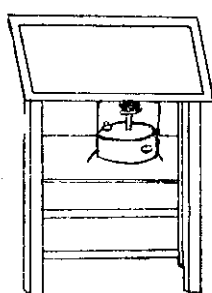

FIG. 13

STOVE & PARAFFIN TRAY

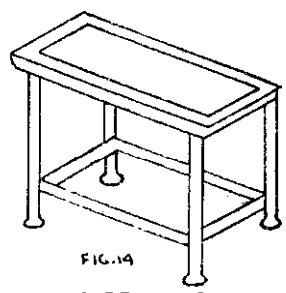
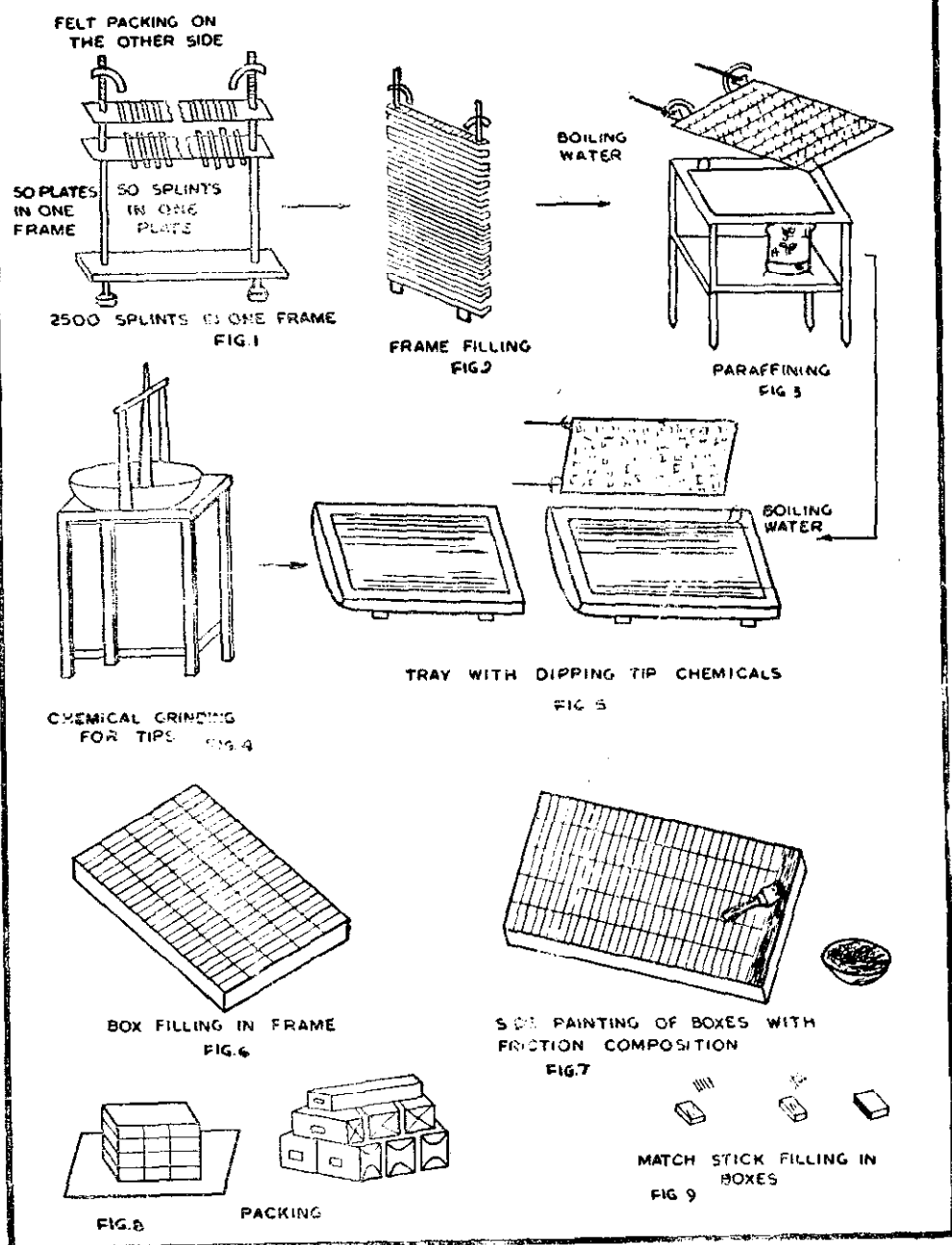

FIG. 14

DIPPING PLATE

SKETCHES OF THE EQUIPMENT USED

PLATE XXIX A



MANUFACTURE OF SURGICAL INSTRUMENTS

(Figures relate to Plate XXX)

Introduction: Many surgical instruments, particularly the non-cutting type, can easily be manufactured on small scale basis. The process involved is so simple that after initial training, specialisation can be achieved very easily. Most of the work can be done by hand without using power and with simple machinery and equipment. There are many items the manufacture of which is quite complicated and therefore machine manufacture is not very suitable for them. They can best be managed by hand. Manufacture of surgical instruments is highly labour intensive. In fact surgical equipment in India is made mostly by small units having only a few machines:

Production programme: The programme envisages the manufacture of instruments most of which do not have cutting edges. Most surgical instruments of the type mentioned below are made of stainless steel rods and strips. Maximum diameter of the rods is 10 mm.

The following instruments are manufactured :

- | | | |
|---|-------|------|
| (1) Forceps of various kinds, like sterilising- syringe-holding- dissecting- capsule holding- fixation forceps- etc.
(Fig. 1, 2, 3, 6) | 1,500 | Nos. |
| (2) Needle holders (Fig. 9) | 500 | " |
| (3) Towel clamps (Fig. 7) | 500 | " |
| (4) Dressing scissors (Fig. 5, 10, 11, 12) | 500 | " |

Manufacturing process : Items made of sheet :

1. Blanking and punching
2. Bending, forging
3. Hand operation
4. Hardening
5. Polishing
6. Cleaning
7. Inspection
8. Packing

The blanks are hand forged. They are then hand filed to correct shapes and then polished. Most of the instruments mentioned above do not need any heat treatment. The heat treatment is given on coal fire when necessary.

Cost economics

Raw Materials

	Rs.
1. Stainless steel equivalent to En 56C, Av. dia. 10 mm. 350 kgs. at Rs. 25 per kg.	8,750
2. Coal 2 tonnes	200
3. Misc. consumables	500
4. Packing	500
	<hr/>
	9,950
Say Rs.	<hr/> 10,000 <hr/>

		Rs.
I. Land and building covered area 400 sq. m. (a shed of 20×20 m.), rented		500.00
II. Machinery and equipment		
(a) Coal fired blacksmith hearths with blowers	2	3,000.00
(b) Anvils	2	500.00
(c) Sewage block	2	500.00
(d) Metal cutting hand saw	1	200.00
(e) Blacksmith tools (sets)	2	500.00
(f) Hand screw presses	1	2,000.00
(g) Drilling machine 1/4" dia.	1	2,000.00
(h) Polishing lathes, double ended	2	6,000.00
(i) Belt and disc. grinder	1	2,000.00
(j) Double edged grinder	2	4,000.00
(k) Hand tool vices	1	1,000.00
(l) Disc forging	1	5,000.00
		<u>26,700.00</u>
Say Rs.		<u>30,000.00</u>

Staff Salary

Proprietor-cum-manager	1	500.00	p.m
Typist-cum-clerk	1	250.00	,,
Blacksmith	2	500.00	,,
Filers/Fitters	4	1000.00	,,
Polishers	2	500.00	,,
Packer	1	250.00	,,
Total		<u>3000.00</u>	

Capital requirement

Total average monthly expenditure :	Rs.
(a) Staff	3,000
(b) Raw materials	10,000
(c) Rent of shed	500
(d) Depreciation of machinery at 10% per annum	250
(e) Interest of capital outlay at 10% per annum	350
	<u>14,100</u>
Say Rs.	<u>14,000</u>

Monthly turnover from sales :

1. 1400 forceps at Rs. 6 each	8,400
2. 500 scissors at Rs. 4/- each	2,000
3. 500 towel clamps at Rs. 6/- each	3,000
4. 500 needle holders at Rs. 6/- each	3,000

Total Rs. 16,400

Monthly profit Rs.16,400—14,000 2,400

Annual profit 28,800

Say Rs. 29,000

PLATE XXX



FIG. 1



FIG. 7

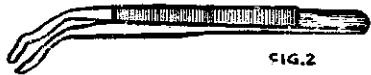

FIG. 2



FIG. 8



FIG. 3



FIG. 9

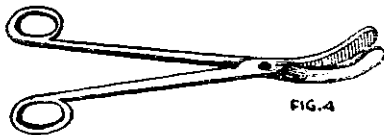

FIG. 4



FIG. 10

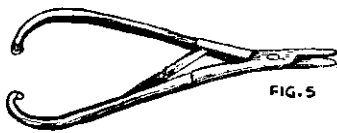

FIG. 5

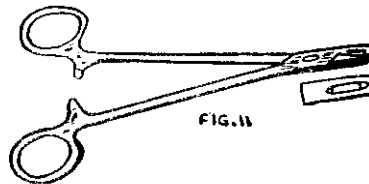

FIG. 11



FIG. 6

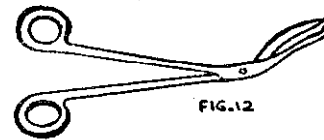

FIG. 12

SCISSORS AND FORCEPS

SURGICAL INSTRUMENT

NON-FERROUS METAL FOUNDRY

(Figures relate to Plate XXXI)

Contact Agency: Small Industries Development Organisation, Nirman Bhawan, New Delhi.

Introduction : Brass and aluminium are utilised as material for making numerous objects of daily use whose utility is so great for common man that the demand for their production is on the increase. For large production of such articles, there is a great need for non-ferrous foundries. Since these foundries do not require electricity or power, they can be very easily set up in the rural areas.

Non-ferrous casting : In the non-ferrous casting group we have the brass, bronze, bearing metals, and aluminium. To make castings of this group, generally one or more metals are melted together.

Process of casting

1. *Pattern making :* The first thing necessary in order to make any sort of metal casting is a model or a pattern.

Make an exact pattern of metal for the casting to be made. Pattern can be supplied by the customers themselves. When the pattern is ready, a mould is accordingly prepared from it.

2. *Mould making :* For making moulds, a special quality of sand is used called moulding sand. For brass and aluminium moulding, sand is usually of a finer grain than that used in ferrous metal casting as the product has to be very smooth.

Smooth castings or castings having better skin may be made by facing the pattern with brass sand to a depth of about one and a half inches.

The pattern is rapped into the flask, that is, the top part being rammed up, a portion of sand is removed and the pattern is laid. At this stage some parting sand is sprinkled. The drag is now placed on the facing sand. Thereafter add ordinary sand and ram until the flask is full. The flasks, top and drag, are then turned over so that the drag is at the lowest end. When the top part is removed and emptied, the face of the drag is to be cleaned again.

After that, the top is put on, the facing sand filled in and the ordinary sand added and rammed up in the usual way. The top part is then taken off once again. Then the patterns are withdrawn from the mould. The mould is ready now for pouring.

3. *Core making :* A core is inserted within a mould when a brass casting is made with holes or hollows.

A core is a shape of baked sand exactly the counterpart of the holes or hollows that are desired. The core is placed in the mould to prevent the molten metal from running into the hollow space.

4. *Crucible :* After the preparation of the mould, it is necessary to melt the metal of which the casting is to be made. This is done in a crucible. When melted in a crucible, the metal does not come into direct contact with fire.

Graphite crucibles are generally used in the brass foundry on account of their great durability. They can stand more heat and rough handling, and can be charged cold.

These are made in standard sizes and are known by their numbers from 1 to 100. A No. 10 crucible has a capacity of 15 kg. of brass or 5 kg. of aluminium.

5. *Operation of crucible furnace* : Charge the metal in the crucible without overloading it and place on the coke bed. Fill in space around the crucible with small pieces of coke upto the top and cover the pot with its lid. When this is done, attention need not be paid to the furnace for about an hour but one should see whether the fire is properly burning. As soon as the metal is hot enough to run the castings, the crucible should be taken out from the furnace, set into the shank and the metal should be poured. The bottom of the furnace and the grate should be kept free from ashes and cinders otherwise the draft will not get through, and will cause much trouble in getting the metal hot enough to run the casting.

6. *Pouring* : Great skill is required in pouring molten metal into the moulds, as the speed with which it should be poured varies with the nature of the work. It should be done slow enough to allow the gas to escape and yet fast enough to keep the metal from chilling in the mould and forming 'cold shuts' as they are called. It is of great importance that the operator should gauge correctly the amount of metal required, for if he does not take enough metal in the ladle to fill the mould, it is practically certain that the casting is lost.

After the pouring of the metal sufficient time should be allowed for the metal to set. In small castings this may be a matter of a few minutes; in large ones it may take some hours or even a week. After the metal has been properly set, the castings are removed from the sand.

Cost Economics

Production

Brass	20 kg./day.
Aluminium	10 kg./day.
				Rs.
Machinery and equipment	7850.00
Raw materials	10030.00
Other expenses	100.00
Number of persons expected to be employed				4
Monthly expected earnings	1513.00

Total recurring expenditure

1. Rent	250.00
2. Raw materials	10030.00
3. Labour	550.00
4. Other expenses	100.00
				<u>10930.00</u>

Non-recurring expenditure

1. Machinery and equipment	7850.00
2. Miscellaneous	500.00
	<hr/>
	8350.00
	<hr/>

Total capital investment

1. Total recurring expenditure	10930.00
2. Non-recurring expenditure	8350.00

Profit and loss account

1. Total recurring expenditure	10930.00
2. Depreciation on machinery and equipment 10%	84.00
3. Interest on capital investment 10%	200.00
	<hr/>
Total	11214.00
	<hr/>

1. Expected production of 505 kg. of brass af- ter allowing wastage of 5 kg. at Rs. 19.00/kg.	9595.00
2. Expected production of 255 kg. of alumi- mium after allowing wastage of 5 kg. at Rs. 12-00/kg	3000.00
	<hr/>
Total	12595.00
	<hr/>

Profit per month = Rs.12595.00—Rs.11214.00=1381.00

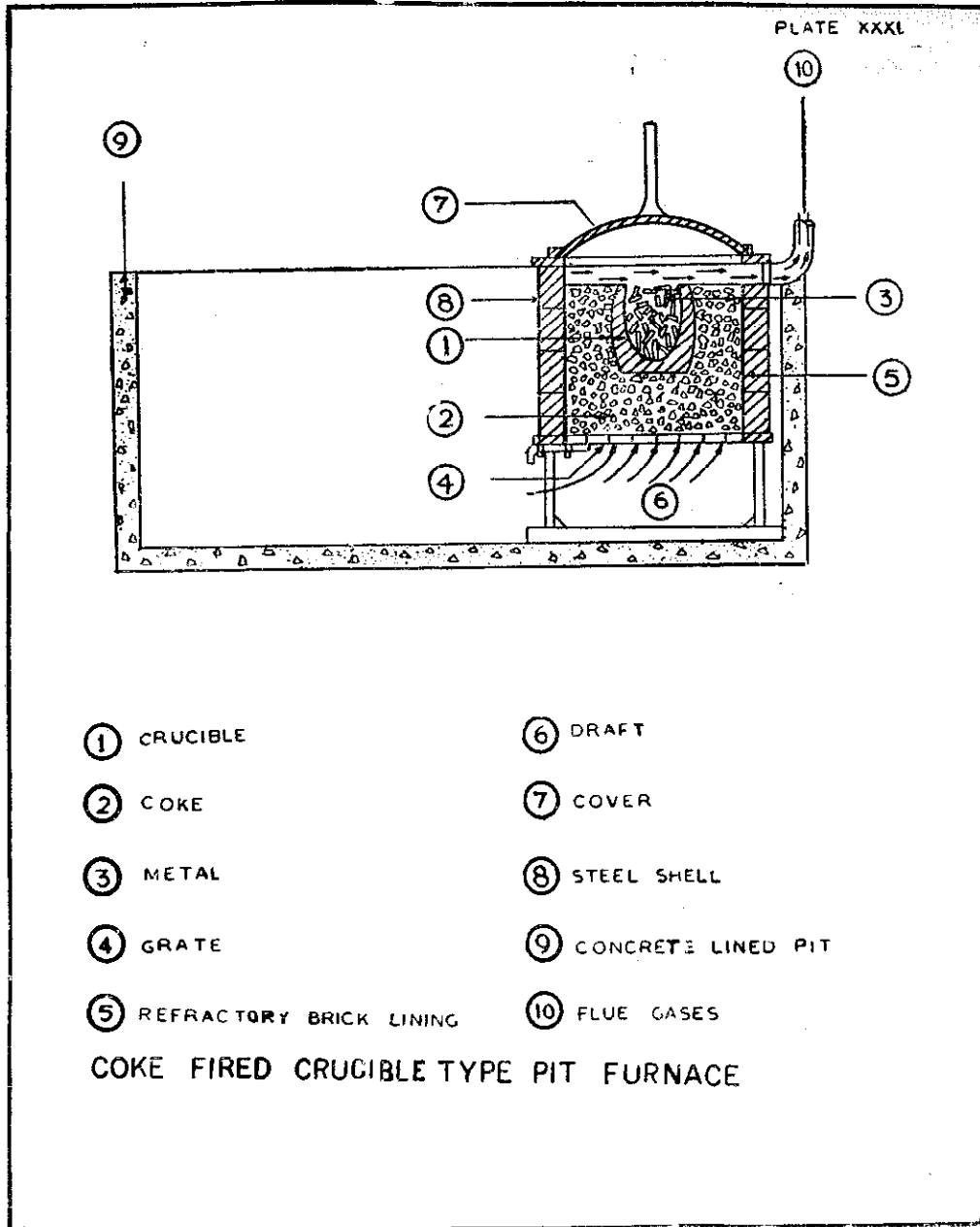

MANUFACTURE OF CHALK CRAYONS

(Figures relate to Plates XXXII, XXXIII, XXXIIB)

Contact Agency: Small Industries Development Organisation, Nirman Bhawan, New Delhi.

Introduction : Chalk crayons are one of the indispensable items for all educational institutions. They are required in every teaching establishment from primary village schools to universities. They are also used extensively in seminars, symposia, meetings and conferences; for illustrations, drawing sketches and writing notes and points of lectures, papers, etc. on the black board.

Product specification : Chalk crayons are plaster of Paris products. They are normally in the form of round tapered sticks. They are generally white but coloured chalks are also used.

Process of manufacture : The process of manufacturing of chalk crayons is very simple and can be easily handled by semiskilled persons. Hardly any machine is used. The main operations involved in chalk manufacturing are :

- I. Preparation of slurry
- II. Moulding or casting
- III. Drying the chalks
- IV. Packing

I. Preparation of slurry : Measured amount of water is taken in a bowl. Plaster of Paris powder is poured slowly into the water. The slurry is then mixed with hand. The slurry thus prepared is made homogeneous. As mentioned above, the powder should always be added to the water and in no case water should be poured into the powder.

The slurry thus prepared sets in about 10 minutes time. The slurry should in no case be prepared more than the moulds can take in one time. It takes 10 to 15 minutes for the chalks to set in the mould.

It is advisable to add small quantity of either ultramarine blue or chinese blue dyes to the water to be used for preparation of slurry. This will help to bleach the yellowish white or grey colour of the chalk sticks.

II. Moulding or casting : The mould should be prepared for moulding before the slurry can be poured into the mould cavity. The moulds are cleaned and a fine film of lubricant is applied. The lubricant consists of acrosin and mustard oil in the ratio of 4:1. The moulds are made of aluminium.

The slurry is then poured into the mould cavity. An enamelled tumbler can be used for pouring. The mould should be shaken after pouring the slurry. This will remove trapped air in the mould cavity. The slurry should be allowed to set in the mould for 10 to 15 minutes.

III. Drying : After the slurry has set in, the moulds are opened and the moulded chalk sticks are carefully removed from the moulds and placed on

wooden trays. They are then put in the sun for drying. Generally the chalks get completely dried in the sun in a day.

Note : The coloured chalks are also produced in the same way, only water colours are added to the slurry to get the desired colour. The coloured chalks should be dried in the shade otherwise the colour will fade away.

IV. Packing : After the chalks are dried, they are collected and then packed in small card board boxes. One hundred chalk sticks are packed in one box. These small boxes can be packed in big cartons as per the need of customers. Generally 100 boxes are packed in one big carton. Saw dust is used in packing to avoid breakage of chalk sticks.

Production requirements

1. Raw material : The main raw material is plaster of Paris. Small amount of china clay can be added to the slurry to make the chalk-sticks softer than those made by plaster of Paris alone.

Water colour is required for coloured chalks.

2. Labour : No special skill is needed. Semi-skilled labour can very easily do the work.

3. Equipment

- (i) Aluminium moulds of 100 sticks each
- (ii) Wooden trays for drying size 1'×2'
- (iii) Enamelled basin
- (iv) Enamelled mug
- (v) Sieve and small tools

Cost economics : (For producing 3000 boxes of 100 crayons each)

I. Non-recurring expenditure

Machinery and equipment

		Rs.	
1.	Aluminium moulds of 100 sticks	100 Rs. 110/- per mould	1100.00
2.	Wooden trays for drying (1'×2')	100 Re 1/- per tray	100.00
3.	Enamelled basin	one Rs. 25	25.00
4.	Enamelled mug for taking out slurry from the basin and pouring	one Rs. 5/-	5.00
5.	Sieve and small tools, etc.		10.00
		Total	1240.00

II. Recurring monthly expenditure

1. Plaster of Paris	40 bags fo 35 g. each	Rs. 15 /bag	600.00
2. Mustard or g. nut oil	.. five kg.	Rs. 10/kg.	50.00
3. Kerosene oil 20 litres	Rs. 1.20 per litre.	24.00
4. Packing boxes	.. 3000	Rs. 15/100	450.00
5. Saw dust 4 Bag	Rs. 5/bag	20.00
6. China clay 2 Bags	Rs. 25/ bag	50.00
7. Ultramarine blue	..		10.00
8. Labour 3 Nos. at Rs. 100 per month		300.00
			<hr/> 1504.00 <hr/>

CAPITAL REQUIREMENT

Non-recurring expenses	1240.00
Recurring expenses per month	1504.00

Profit and loss account

Cost of production of 3000 boxes of 100 crayons each	1504.00
Interest on capital at 10%	11.00
	<hr/> Total
	1515.00
Income from sale of 300 boxes of 100 crayons each at Rs.65 per 100 box	1950.0
Monthly profit 1950—1515	435.00

PLATE XXXII

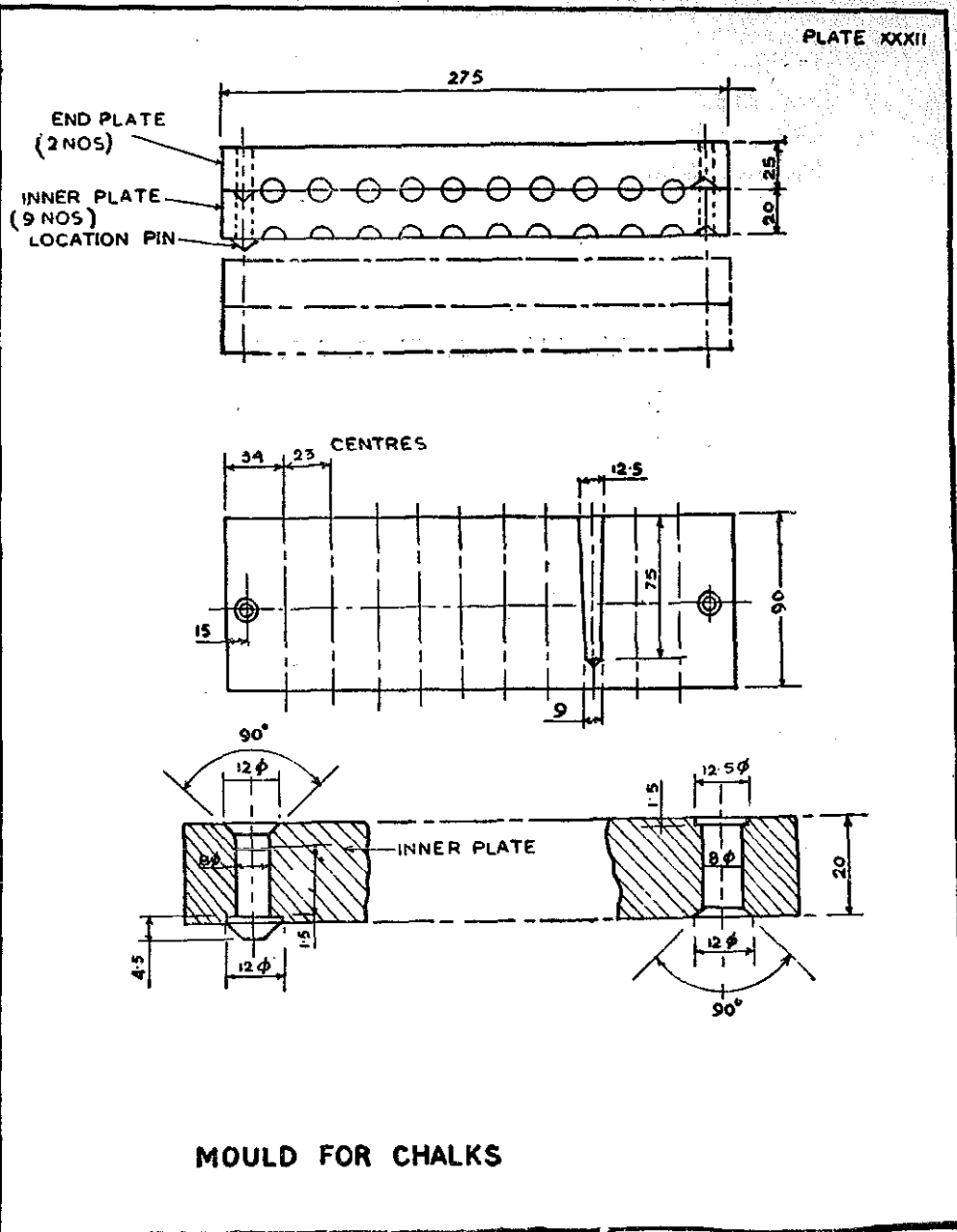

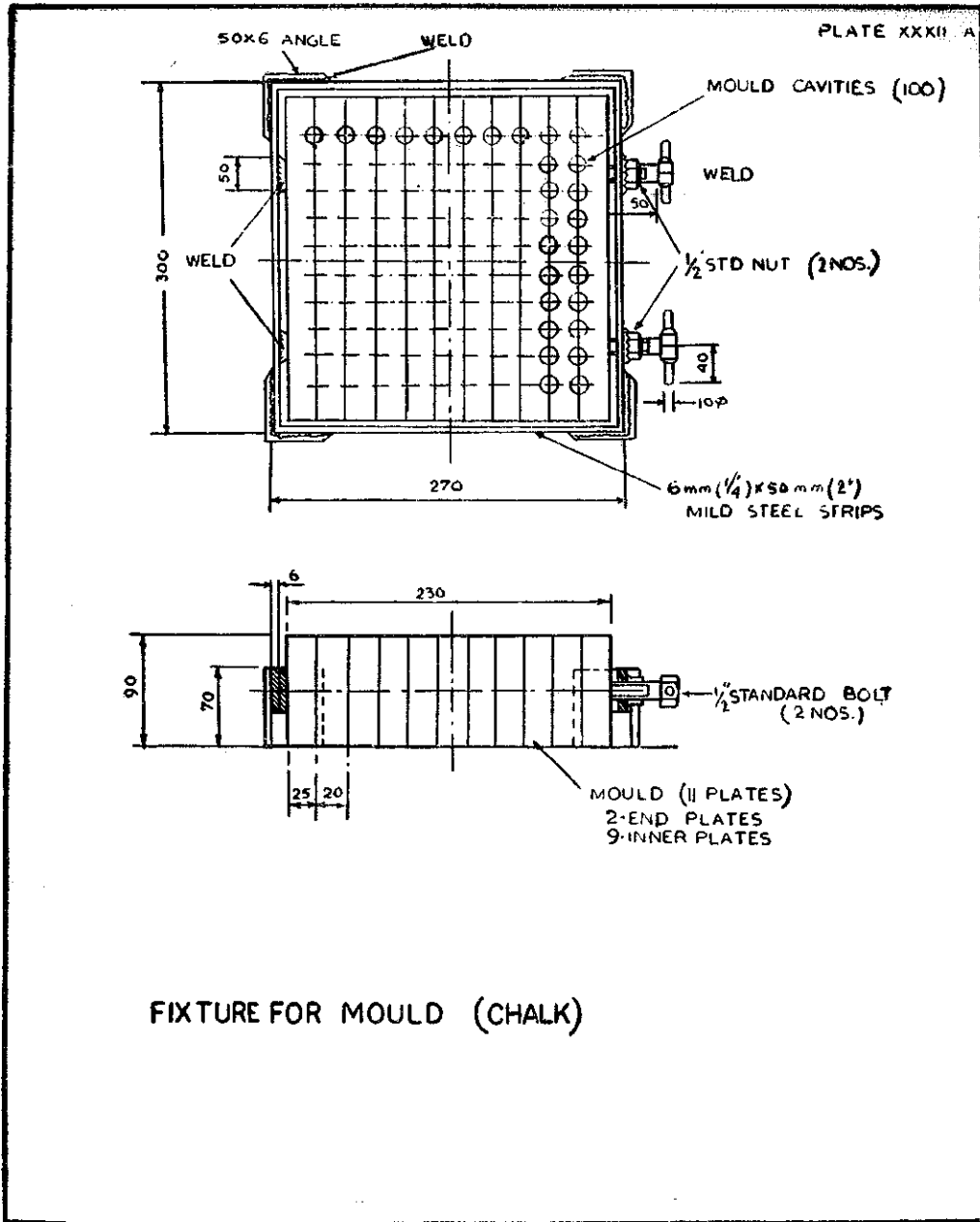

PLATE XXXII B

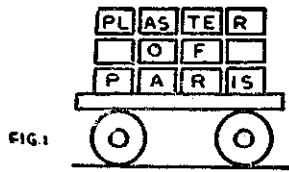

FIG. 1
RAW MATERIAL

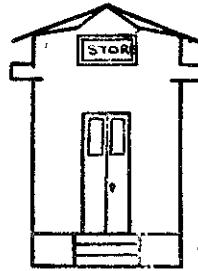

FIG. 2
STORING

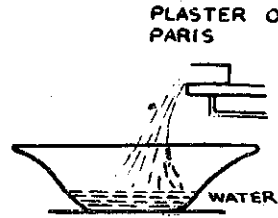

FIG. 3
MIXING

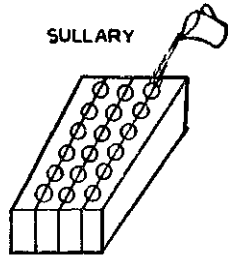

FIG. 4
MOULDING

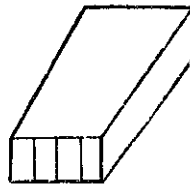

FIG. 5
SETTING

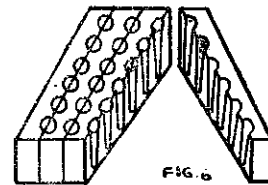

FIG. 6
STICKS OUT OF MOULD

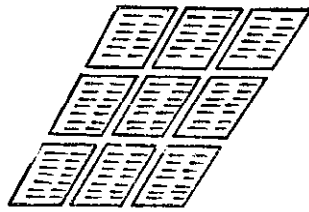

FIG. 7
DRYING

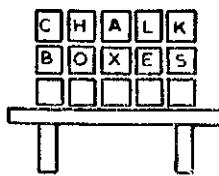

FIG. 8
PACKING

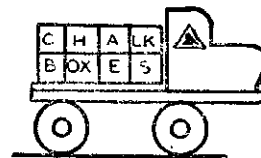

FIG. 9
TRANSPORT

MANUFACTURING PROCESS

CANDLE MAKING

(*Figures relate to Plate XXXIII*)

Introduction : Electricity is not available everywhere and all the time. Kerosene oil is becoming expensive and scarce due to the oil crisis. The candles have their own role to play in times of electricity failure. It is handy and mobile and can be carried everywhere, in trains or to far off places. The scope of wax candle has therefore become greater, specially in small towns, villages and during travels. In western countries candle making is a specialised art; they make high quality candles for decoration and ornamental purposes. In India, it is a necessity to dispel darkness on occasions when no other means of lighting is available. In comparison with other industries, wax industry is one of the easiest to start with small capital and offers reasonable monetary profit as well.

Raw material

(1) Paraffin wax : A translucent petroleum by-product. Bees wax can also be used but it is expensive and generally used for more sophisticated purposes.

(2) Wick : It is made from bleached cotton yarn, loosely spun so that it may burn easily.

(3) Colours : For producing coloured candles, an oil soluble dye is used.

Appliances

(1) Moulds—These moulds are made of aluminium; some times alloys (Fig. 1). For different sizes of candle, a number of moulds are to be obtained.

(2) Ladle : For pouring the liquid wax into the mould. (Fig. 2).

(3) Stove "chulah"—For melting the wax. (Fig. 2).

(4) Cauldron (karahi) in which wax would be melted. (Fig. 2).

Manufacturing process

(1) The mould is in two parts. Take out the side clamps so that both parts of the mould are separated. Now insert into the cavities a cotton swab soaked in mobil oil or any other oil and rub in both the parts of the mould. This is necessary to take out candles from moulds without difficulty.

(2) Now follow the wick marks on the wick holder and bind wicks in the mould. Bring both the parts of the mould together and clip them.

(3) Melt paraffin wax in a cauldron (karahi) over a slow fire. If coloured candles are to be produced, mix a little quantity of oil colour in the molten mass.

(4) Take a big ladle and pour molten wax in the mould upto the top with the ladle.

(5) In a shallow pan, fill cold water and keep the mould in it to enable the wax to harden quickly.

(6) Wax will become solid within a few minutes. Now take out the mould from the water, open it and remove the candles. Excess wick should be cut off with a blade.

Packing : Candles are now packed in strong paper or in cardboard packets. A label is pasted on the packet. You can print your own labels or can purchase beautifully printed ready-made labels from the market.

Novelty candles : If one is already making candles or wishes to start candle industry, here is a good idea for making more money in candles. One can make artistic shapes : candle like toys, animals and other curious shapes. They can be sold on special occasions like Deepawali, X-mas, Shab-brat, Independence day and birthdays, etc. Some specimen of artistic candles made in high quality plaster of Paris mould are shown in Fig. 3.

Price of these moulds is Rs.10 per mould.

Cost economics : The candle industry can be started with modest capital and one self-employed person can turn out a large number of candles per day.

WAX MELTING PAN

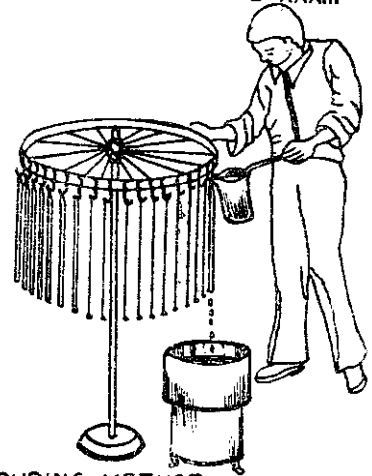
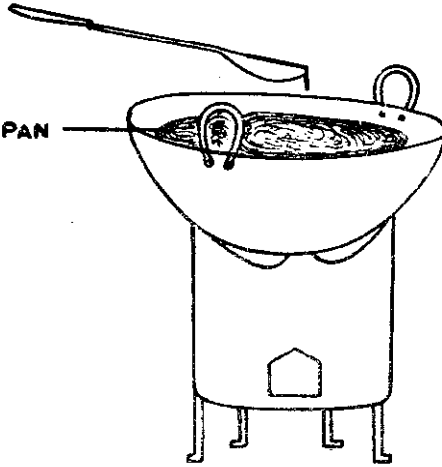

POURING METHOD

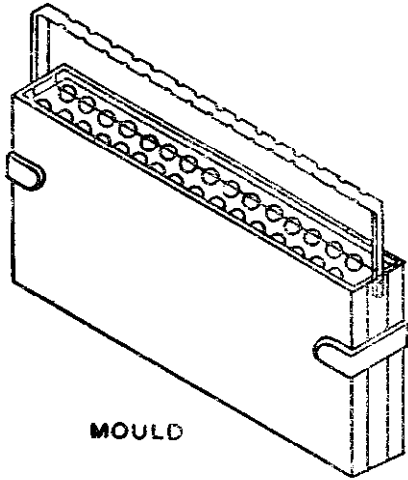

MOULD

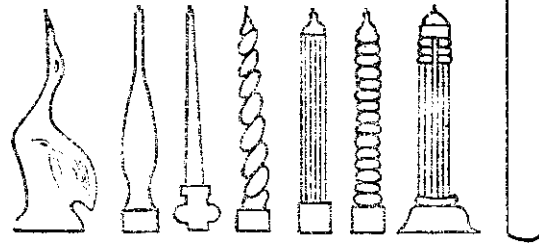

VARIOUS SHAPES OF CANDLES

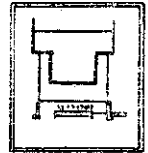

CANDLE MAKING

SOAP MAKING

(Figures relate to Plates XXXIV, XXXXIVA, XXXIVB, and XXXIVC)

Introduction : Cleanliness is next to godliness, and soap helps a lot in cleanliness. Even in primitive times, man felt the necessity of cleansing his body, his clothes and his utensils, etc. These days soap is an essential item for every man in the world. So there is no risk in soap making because it is one of the most essential consumer items of the common people. There are so many soap making industries and all are earning good money.

Appliances :

1. Frying pan (kadai)
2. Enamel kettle with cocks, one at the bottom, one in middle and one intermediate between the two. (Figs. 2, 3, Plate XXXIV).
3. A piece of glass pan
4. Caustic lye tank for storage (Plate XXXIVA)
5. Oil containers
6. Bucket
7. Scale and weights
8. Wooden or iron spoon or ladles for stirring
9. Segrees for melting oil and preparing soap on a very small scale
10. Furnace (bhatti)
11. Thermometer and hydrometer
12. Ordinary tins, knives or spatulas, tin pots, etc.
13. Racks or shelves for drying soap
14. Foam removing slubber, a slabber, bar cutter. etc. (Plate XXXIVB)
15. Soap cutting table
16. Bar stamping dies and stamping machine (Plate XXXIVC)

Raw materials : Common soaps are manufactured by combination of animal- or vegetable fat with alkalis, caustic soda or caustic potash in presence of water. Sometimes a host of other materials such as soda ash, silicate of soda, french chalk, china clay and starch are used as adulterants and perfumes and dyes are used to give a desirable colour and fragrance.

Oil and fat : Following oils and fats are used in soap making, however it is better to avoid edible oils and use non-edible oils.

1. *Cocoonut oil*—Soap obtained from this oil is hard and brittle. It lathers freely in soft and hard water. It is good for cold process. It gives more glycerine but its soap gives bad smell after some time. It is partly used for making toilet soap.

2. *Mahua oil*—This is thick oil; soap of this oil produces good lather. It is largely used with other oils due to its cheapness.

3. *Linseed oil*—This is used for making soft and transparent soap. It is not used in household and toilet soaps. This soap is readily soluble in water.

4. *Khakan oil*—This oil is obtained from the seed of an evergreen shrub known in botany as *salvadora oleoids*. The properties of the soap made out of it are similar to those of cocoanut oil.

5. *Groundnut oil*—It gives a soft bodied soap with fairly good cleansing properties and lathers very slowly. Its action on the skin is very mild and hence its addition in toilet soaps is beneficial. The oil does not saponify easily.

6. *Neem seed oil*—It saponifies readily and gives a hard grained soap with good lathering properties. In graining the soap, most of the disagreeable odour disappears. The soap is used as an antiseptic also.

7. *Cotton seed*—The soap of this oil gives bad smell after some time. So it is used by mixing with other oils.

8. *Malabar tallow*—It is also known as piney or dhupa fat and is obtained from the seeds of an ever green tree known as *vateria Indica*. It makes an excellent soap for washing and toilet purposes. It approaches animal tallow in its soap making properties and hence it can be used in its place.

9. *Animal tallow*—For the purpose of soap making it is obtained from the marrows of the bones of animals and called bone fat, bone grease or bone tallow. This makes hard, uniform and slow lathering soap. This soap can stay for a long time in good condition.

10. *Lard*—This is tallow of pig and used for making high quality toilet soap or shaving soap. This is very costly

11. *Karanja oil*—*Karanja* oil, is obtained from seeds of a tree *pongamia olabar*. By refining, it can be used for soap making otherwise the soap gives bad smell. It is used with other oils.

12. *Acid oil*—It is cheaper and makes hard and good soap. It may be obtained from vegetable oil (ghee) makers.

13. *Sludge gaad* : A good soap can be prepared by mixing any other oil in this sludge. The sludge or gaad is obtained during the preparation of vegetable ghee.

14. *Rosin*—Rosin is obtained as a by-product in the distillation of an oleo-resin gum for turpentine. Rosin imparts lathering, softness and cleaning properties to soap, improving its texture. It is not added pure but in admixture with other oils and fats. It is generally not used in toilet soap.

15. *Essential oils*—These are only used in very small quantities to give the soap a pleasant fragrance. The oils widely used are as follows:

- | | |
|---------------------|----------------------|
| (1) Clove oil | (7) Musk |
| (2) Cinnamon oil | (8) Essence of roses |
| (3) Anise oil | (9) Sandal wood oil |
| (4) Ajwain oil | (10) Kuda |
| (5) Lemon oil | (11) Khas |
| (6) Orange peel oil | |

Alkalis : Important alkalis which are used in soap making are :

- (1) Strong alkalis—caustic soda and caustic potash
- (2) Mild alkalis—potassium carbonate and sodium carbonate

Caustic soda : This is a strong alkali because of its strong action and is popularly used for making hard soap. It is hygroscopic. It absorbs carbon dioxide from air and converts it into carbonate. Caustic soda is manufactured from common salt by electrolysis; chlorine or bleaching powder being a by-product. It is also manufactured from soda ash (sodium-carbonate) by mixing its solution with the requisite amount of slaked lime. Soda ash 106 parts and slaked lime 74 parts give caustic soda 80 parts and lime (raw) 100 parts.

Caustic potash : Chemical properties of caustic potash are similar to those of caustic soda. But there is much difference in quality of soaps made from these two. Caustic potash makes soft soap while caustic soda makes hard. Caustic potash is obtained from wood ashes known as pearl ash. The plants that produce pearl ash containing most potassium carbonate are, 1. annual weeds, 2. aghada, 3. dhatoda vesika—adulsa. To produce caustic potash the concentrated liquors obtained from the extraction of ashes with water are mixed with slaked lime paste. The extracted lyes of crude potash are evaporated to a strength of 30 to 35 per cent normally and kept in a closed drum or tin.

Mild alkalis : Potassium carbonate and sodium carbonate are termed mild alkalis, because they have no irritating or burning action on the skin. They do not combine directly with oils to form soap. They combine directly with rosin and fatty acids to form soaps with great effervescence. On that account great care is required while making rosin and fatty acid soaps with these mild alkalis, as otherwise the soap will spill over. When mixed with slaked lime they give what are known as strong alkalis.

Sodium chloride : Sodium chloride is used for graining the soap in the full boil process. It plays an indirect part in soap manufacturing.

Water : Water is an important intermediary substance in bringing about the chemical combination between the oils and lyes.

Soap making processes : Soap making consists of the art of chemically combining the oils with the caustic alkalis. The quantities of caustic soda or potash required by individual oils should be determined in each case. The chemical change that takes place may be described by the following equations.

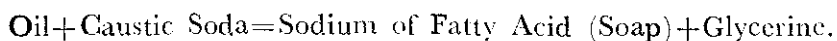
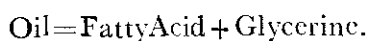

The glycerine liberated by oil is approximately 9 to 10%

There are two main soap-making processes, namely, the cold process used with commercial lye (caustic soda) and the warm process used with leached lye.

Cold process : A cold process recipe, which makes about 9 lbs (4 kgs.) of soap is as follows :

Ingredients : 6 lbs. or 7.75 kg. of clean fat or oil
13 ounce (370 gms.) or lye
1.2 litres of soft water

(1) To clean the fat, melt it and strain out any other foreign matter or particles. A more thorough way is to boil it with an equal amount of water, strain it, add cold water, let it cool and then skim the fat off the top.

(2) Add the lye to the water gradually. The mixture will get hot and may spatter. Rinse your hands immediately if the lye crystals or solution falls on them.

Use pots of iron, clay or enamel and utensils of wood for all stages of soap-making. Never use aluminium, because the lye solution will dissolve it. Let the lye solution cool to body temperature. Check the temperature by feeling the outside of the pot. Do not put your finger in the solution.

(3) Melt the fat and let it cool to body temperature. Stir it as it cools. When the spoon starts to leave a track in the mixture, the temperature is right.

(4) Add the lye solution slowly, drop by drop or in thin stream, to the fat while stirring constantly in one direction. Continue constantly stirring until the mixture is of the consistency of honey or thick cream. If you are using a mixture of fat and oil, this should take about 30 minutes. But if only oil is used, it may take several hours.

(5) When the mixture reaches the consistency of honey or thick cream pour it into the mould or cooling frame. This is a shallow wooden box lined with cotton cloth soaked in hot water and wrung out. The cloth should be big enough to overlap the edge of the box by a couple of inches. This will help in removing the soap. Let the soap stand for 48 hours in a warm, dry place where it will not be disturbed. If it is moved or struck during this period, the ingredients may separate.

(6) Stack the bars in an open place so that air can circulate around and through them. Leave them in a warm dry place for 2 to 4 weeks. When soap becomes hard, it may be used.

Warm process

(1) Pour the oil into the soap kettle and heat upto 140°F.

(2) When the correct temperature is reached, pour in the required amount of caustic soda and stir well and leave it for some time.

(3) It will be seen that the mixture forms grains like coarse wheat flour (suji). Keep it stirring for some time and leave undisturbed for about 10 minutes, when it will form more and more grains. By repeating this process of stirring and waiting, the whole mixture will ultimately become thickly granulated like shira (cooked suji). Continue stirring till the grains change into a soft honey like mass or curd.

(4) At this stage the mixture of oil and caustic is in 3 portions—caustic soda, free oil and the soft brown curd. As the mixture is stirred more and more, the curds become bigger and bigger, the caustic soda lye and oil diminish in quantity. Ultimately all the oil and caustic lye disappear and the whole mixture appears like jelly or honey.

(5) At this stage, if you desire some fragrance in soap, you may add perfumes or essential oil and stir to make uniform paste.

(6) Now pour the mixture into cooling frame. Leave the cooling frame in the warm, dry place until the soap sets in hard form. It takes generally 3, 4 or more days for solidifying or setting.

(7) The solid block of soap, after being removed from the frames is kept in the air for making the surfaces dry, before it is cut to the required sizes.

(8) In the cutting processes first scrape the layer which is frothy and irregular. Slab the block by wire after the preparation as shown in Plate XXXIVC. Cut the slabs into bar by some wire or bar cutter as in Plate XXXIVC. You may sell these bars in the market or you can make cakes of these bars. These cakes can be sold in the market, after finishing. Finishing operation is done by a stamping machine or dies of various shapes according to the size of the soap as shown in Plate XXXIVD.

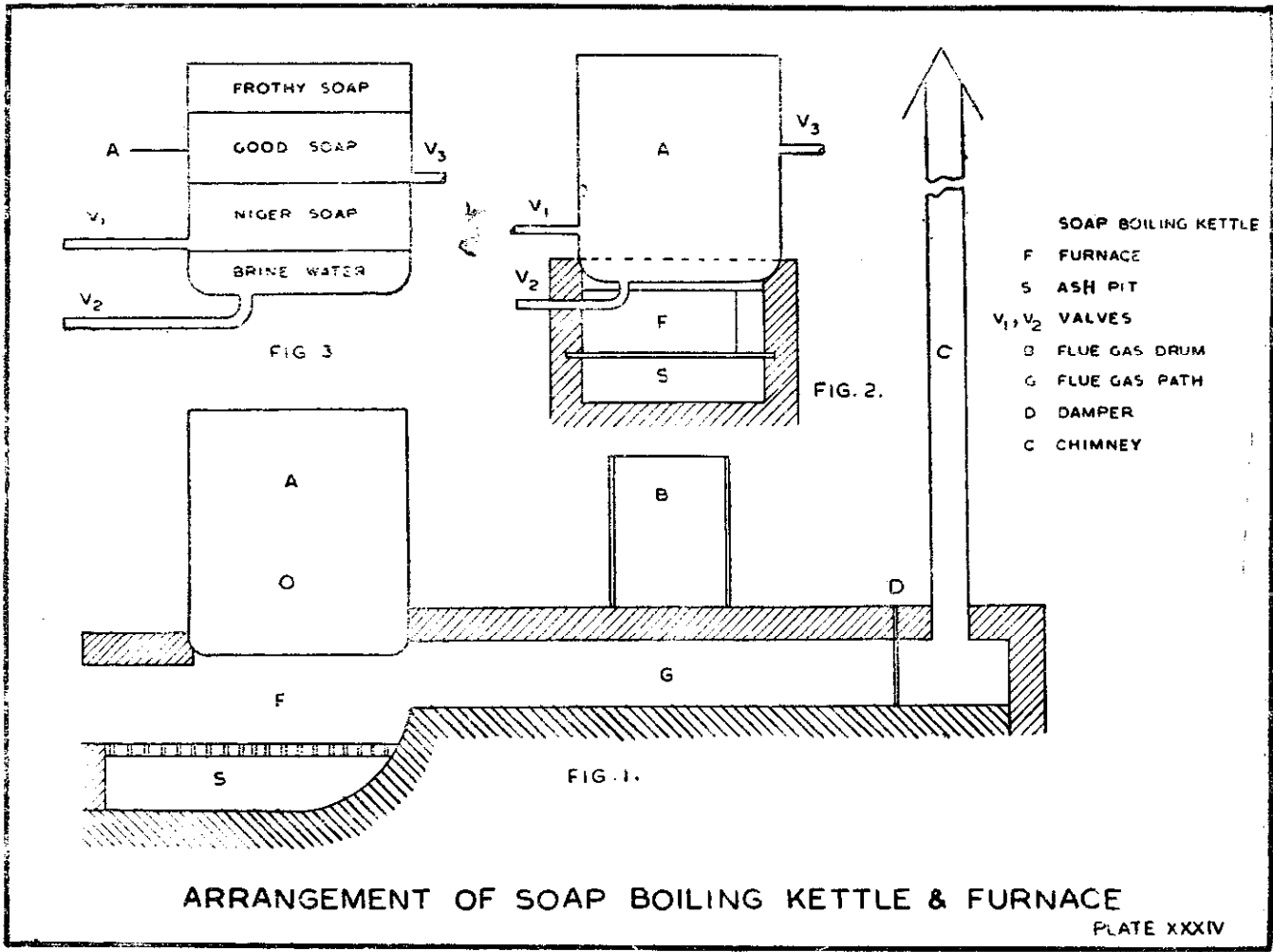

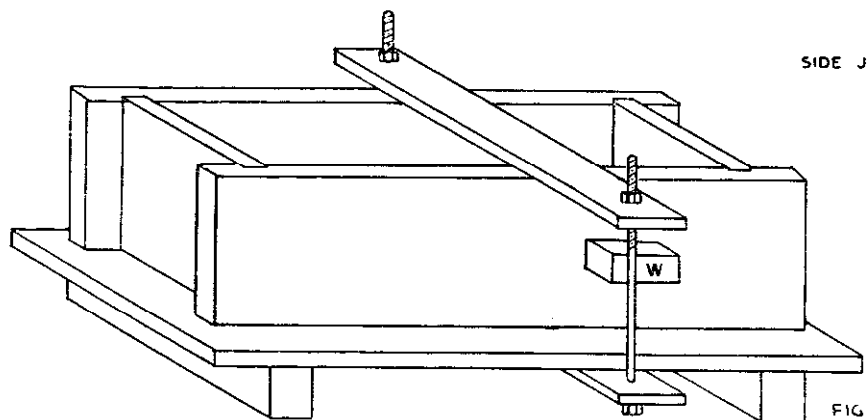

SIDE JOINT

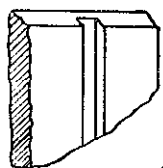

FIG 1



LOWER JOINT
FIG 2

SOAP COOLING FRAME

A B C & D ARE FOUR DIFFERENT
TANKS OF THE REQUISITE
CAPACITY

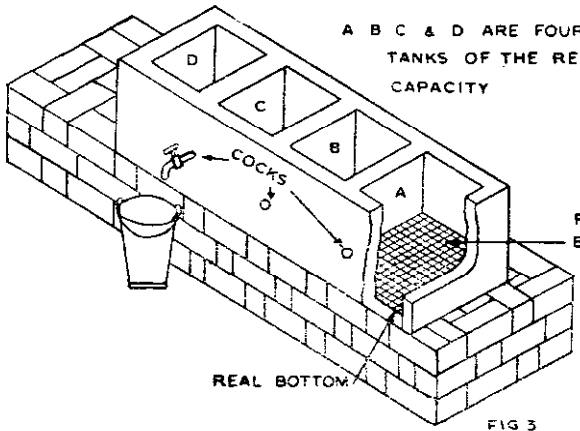

FALSE BOTTOM
BAMBOO STRIPS

REAL BOTTOM

FIG 3

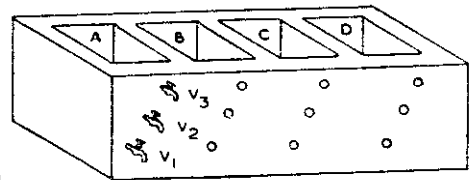
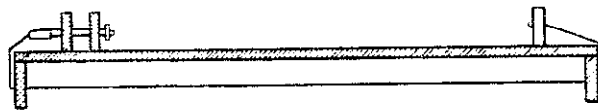

FIG 4

V₁ V₂ AND V₃ ARE VALVES TO TAKE OUT
THE LIQUID AT DIFFERENT LEVELS

CAUSTICISING TANKS



SECTIONAL ELEVATION

FIG. 1

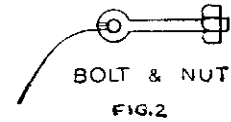

BOLT & NUT

FIG. 2

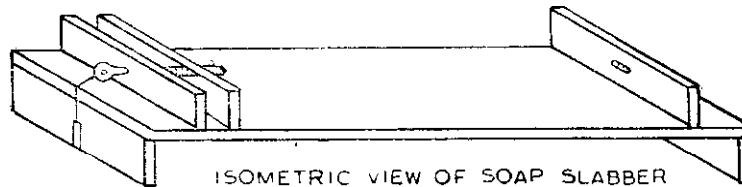

ISOMETRIC VIEW OF SOAP SLABBER

FIG. 3

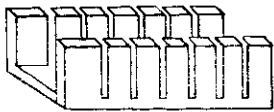

CAKE CUTTING FRAME

FIG. 4

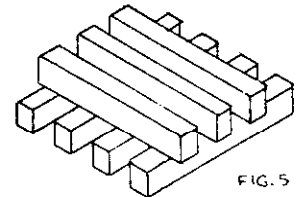

FIG. 5

PILING OF SOAP BAR

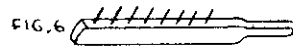
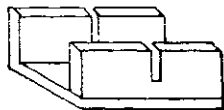

FIG. 6

SLAB MARKER



BAR CUTTER FRAME

FIG. 7

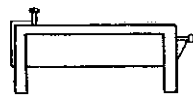

BAR CUTTER

FIG. 8

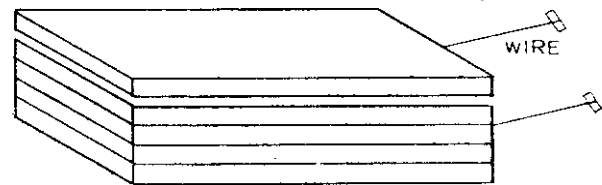

WIRE

SOAP SLABBING BY SINGLE WIRE

FIG. 9

SOAP SLABBER

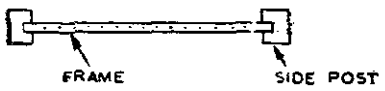

FIG. 1

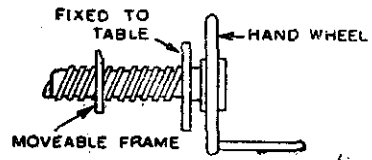

FIG. 2

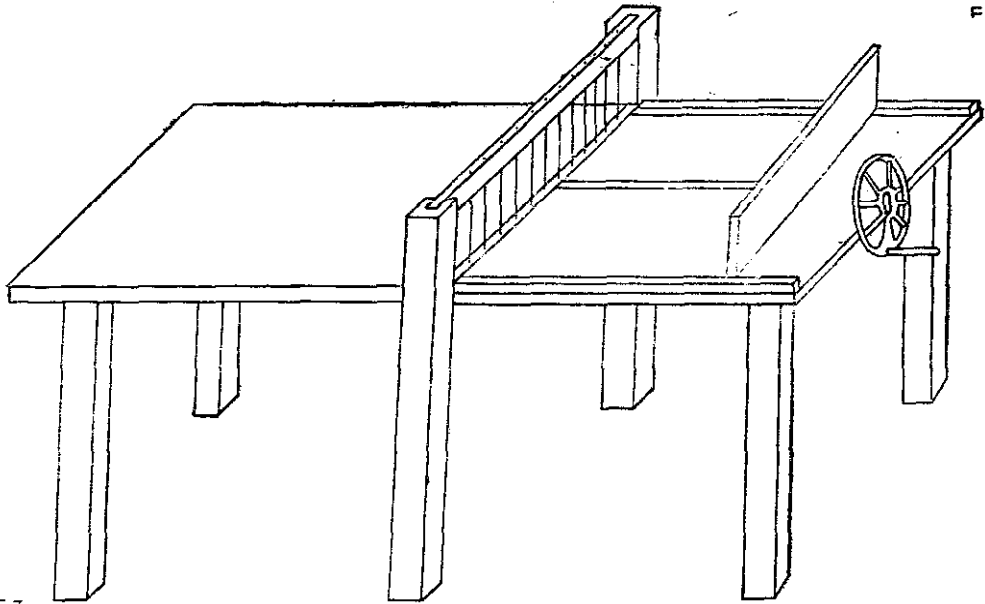
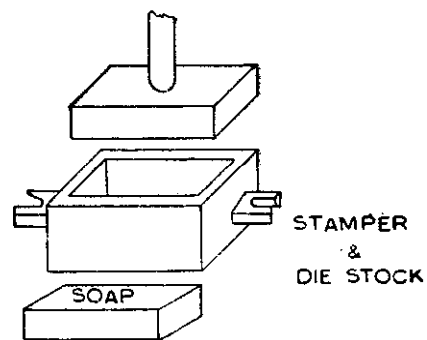
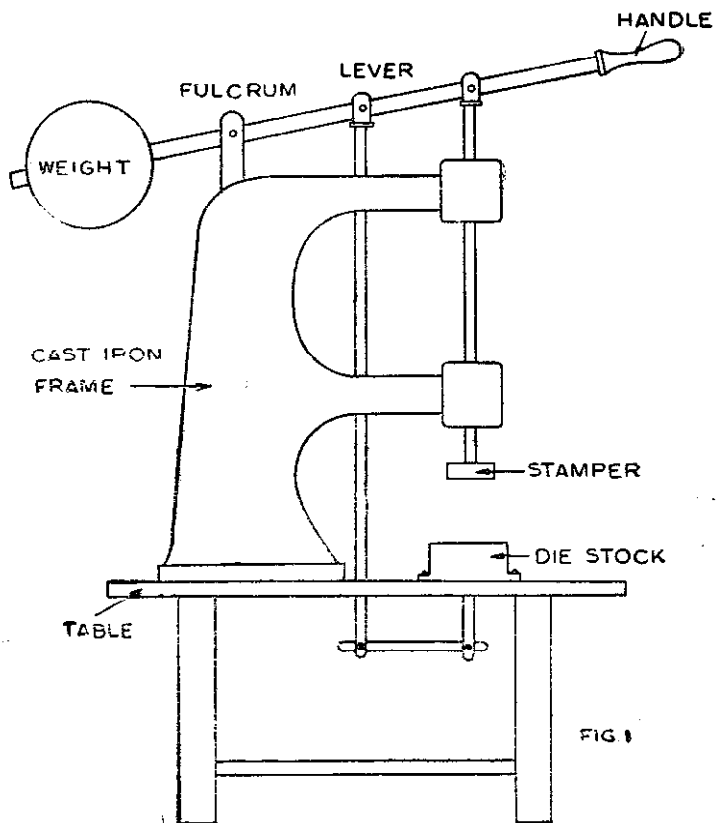

FIG. 3

TABLE FOR BAR & CAKE CUTTING

PLATE XXXIV C



SOAP STAMPING MACHINE

BEE KEEPING

(*Figures relate to Plates XXV, XXVA*)

Contact Agency: Khadi and Village Industries Commission, Irla Road, Vile Parle, Bombay-56.

Introduction : Honey is one of the most nourishing foods in the world and its nutritive value is rated very high. It is known to man from very ancient times. And yet no effort was made to tame the bees and no one ever thought of keeping bees as pets and getting a regular crop of honey from the beehives. It is due to the effort of Huber that new houses for bees were designed and bee keeping and honey extraction are now learnt as art and science. Bee keeping nowadays has been so perfected that any one with a little training can do it and earn a livelihood out of it. Its importance is increasing day by day due to the usefulness of bees for pollination of seeds and fruit crops. In many developing countries, farmers hire beehives during the flowering period, specially for this purpose, and have obtained a production increase of upto 25%. Many uses of bees-wax have also been developed these days and it has become a very expensive item, being the base of cosmetic and polish industries.

Equipment : The minimum equipment required to start this small industry includes the beehive box, smoker, and extractor. A hive box is usually made of gamhar or teak wood. A complete box contains several separable parts termed as top cover, chamber, and floor board. There are two chambers, one for honey called super chamber and the other for brood rearing called brood chamber. The chamber has several movable frames numbering 8 to 10 each containing a comb parallel to one another. (Fig. 2 and 4, Plate XXXV).

A smoke producing equipment, (Fig. 4, Plate XXXVA), is used at the time of handling bees so that they may not sting. An extractor, (Fig. 3), is used for extracting honey from the upper comb frames.

Honey is extracted only in honey flow periods which fluctuate according to agro-climatic and floral conditions of the region.

Type of bees : A bee colony is a complete biological unit composed of thousands of worker bees, hundreds of drones and only one queen. In nature, they dwell in the dark on wax combs, the cells of which contain eggs, larvae and pupae, called brood. The brood is in the form of a sphere in the lower part of the comb; on the top and on each side is the bin of stored pollen and beyond this honey is stored.

The workers compose the bulk of the population and their main task is to look after the colony in all respects. The drone or male bees are required to fertilise the virgin queen. The queen is the only fully developed female and is in fact an egg-laying machine. She never goes out of the hive after mating, except at the time of swarming or laying the foundation of another colony.

Management includes the adjustment and fulfilling of the colony's demands. This can only be fulfilled, when the bees are frequently observed. The colonies should be kept clean and strong to prevent from attack of disease or enemy. Before absconding, the bees stop their activities and the queen suspends egg laying.

Swarming takes place only in the favourable season, when there is abundance of food supply. In lean seasons, when there is dearth of natural bee-flora, it becomes essential to feed bee-colonies with sugar solution. The queen should be renewed yearly by replacing the old ones.

Bee-flora : All plants do not provide nectaries to bees for honey; there are only some selected plants which they approach for nectaries, pollen or both. These plants are called bee-flora. Some of the important bee-flora are the following ornamental plants :

Flowers : corn flower, coral creeper, cosmos, poppy, portula, sun-flower, zinnia, etc.

Fruits : banana, berries, citrus, apples, pears, cherry, guava, jamun, lichi, etc.

Crops : rape mustard, taramira, toria, berseem, maize, til, jute, sorghum, etc.

Trees : tamarind, drumstick, sandal, sisoo, soapnut, neem, etc.

Vegetable: most of the vegetables, but they are minor source of pollen and nectary.

References

1. Bee is Farmer's Honey : M. Naim, Indian Farming, January 1973.
2. IS : 1515:1969 : Indian Standards Institute, 9, Bahadur Shah Zafar Marg, New Delhi.
3. Shahad Udyog : Om Prakash, Sarvodaya Prakashan, Chowk Bazar, New Delhi.

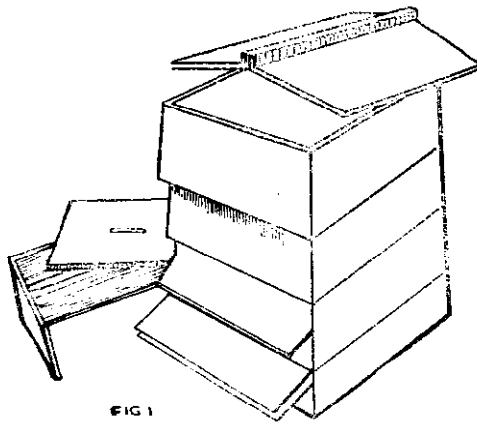

FIG 1

NEW HOUSE OF BEE'S

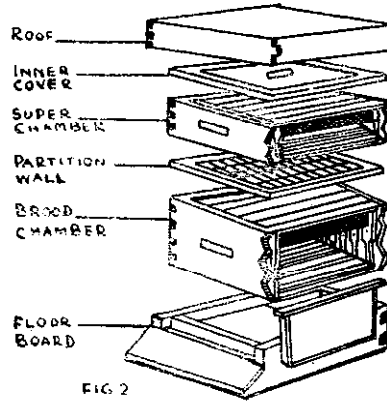

FIG 2

COMPARTMENT OF BEE'S
NEW HOUSE



FIG 3

FRAME CONTAINING HONEY

BEE KEEPING

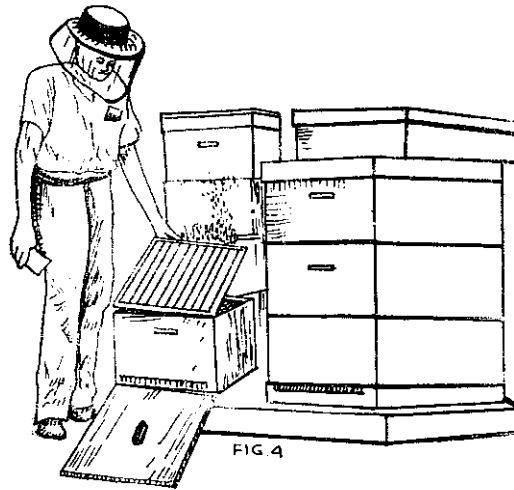
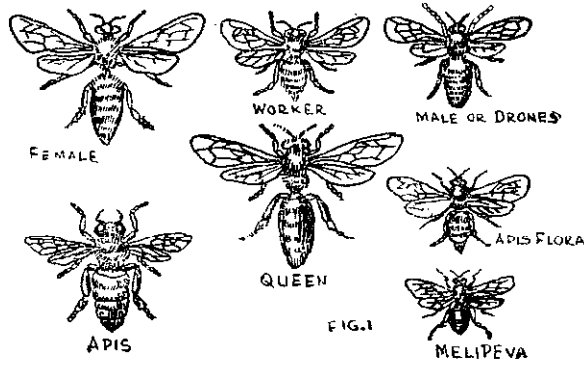
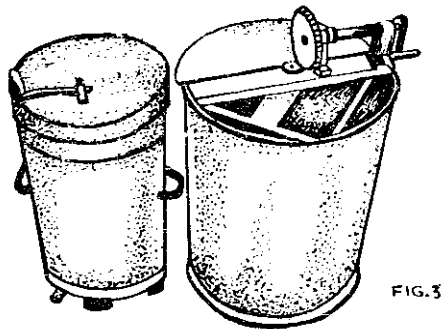

FIG 4

CORRECT METHOD OF INSPECTING THE
BEE'S HOUSE



A SKILLED BEE KEEPER IS PLAYING THE BEE BY HIS HAND



EQUIPMENT USED FOR EXTRACTING HONEY FROM BEEHIVES

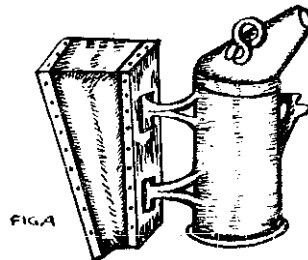

SMOKEPRODUCING EQUIPMENT

BEE KEEPING

Material handling and Transport

INTRODUCTION

Carrying of loads either on head or on back by workers—men, women and children—is a common feature at the construction sites, markets, railway stations and other places. Such a method of carrying loads, handling materials or transporting commodities is rather primitive, tiring and inefficient. A large number of appliances and equipments have been devised all over the world for material handling and transport. But in India we are still using old methods which are inefficient and unscientific. The bullock-cart, one of the most important goods transport industry after rail road, has been left totally to stagnate with little improvement in its design and working. Similarly, rickshaws, a transport that gives employment to poor men in urban areas, have not received any attention. Wheel-barrows, pulley blocks, screw jacks are not used in the villages for the work of material handling and transport. If introduced imaginatively, after proper modifications, such gadgets and appliances can help the villagers and poor people in carrying out their activities more efficiently and economically. A few of the new designs of such equipment developed and experimented in some places have been included in this section.

A WINCH USED IN DIGGING WELL

(Figures relate to Plate XXXVI)

Contact Agency: Friends Rural Centre, Rasulia, M.P.

Introduction: The task of raising excavated earth when digging a well may be considerably lightened and speeded up by the use of a simple winch. Such a winch can be made by a village carpenter. The design and method of manufacture are given below, but there is no need to adhere strictly to the dimensions. Any strong wood is suitable as material.

The winch can also be used for drawing bucketful of water from wells.

Materials

(i) Two beams approximately $3'' \times 7'' \times 12''$ which can be made by sawing through the centre of a log minimum $7''$ dia. and then squaring the two sides.

(ii) Two pieces for upright members approx. $2'' \times 6'' \times 3\frac{1}{2}''$.

(iii) One roller approx. $7''$ in dia. and $3'8''$ in length. It can be made by sawing a log of suitable diameter through the centre and then chiselling a channel out of the two halves to accommodate the steel shaft, at the two ends of which handles are fitted for rotating the winch roller. The shaft should extend beyond the roller by eight inches at each end. One inch square shaft is most suitable because it prevents the shaft from revolving free inside the roller. The part of the shaft outside the roller is rounded to act as a bearing.

(iv) 3 pieces of $1\frac{1}{2}''$ pipe two of them $4'$ long and one $3'9''$ long.

(v) 3 pieces of rod $5/8''$ dia. threaded at both ends with washers and nuts of $4'2''$, $4'8''$ and $4'8''$ length.

(vi) One steel shaft $1''$ square $5'$ long rounded for and at each end.

(vii) $4\frac{1}{2}'' \times 6''$ bolts with washers.

(viii) Two handles made of $\frac{1}{2}'' \times 1\frac{1}{8}''$ one on each side steel flat or of wood to turn the roller.

PLATE XXXVI

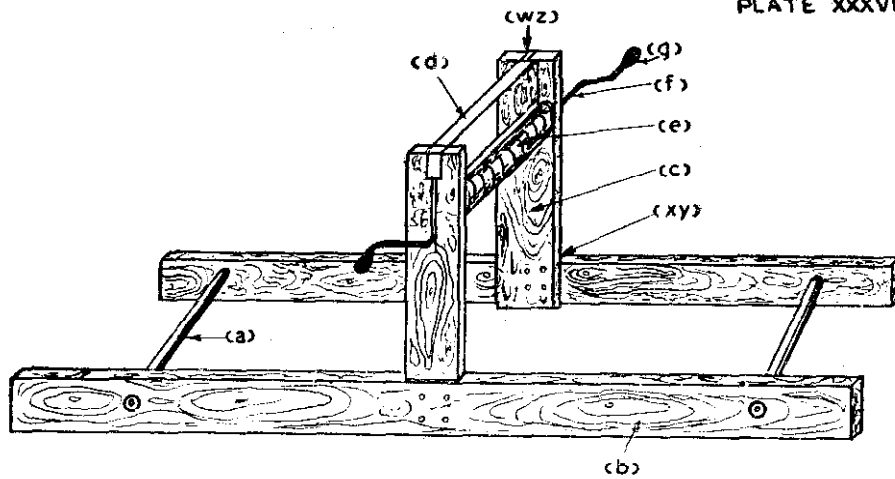

- | | | | | | |
|----------------|-----------------|-----------|-----------------|-----------------------|-------------|
| (a) SPACERS | 2 X 1" PIPE | 50" LONG. | (e) ROLLER | 7" DIA, | 3'-8" LONG. |
| (b) BASE | 2 X 2 1/2" X 7" | | (f) STEEL SHAFT | 1" SQUARE, | 5" LONG. |
| (c) UPRIGHTS | 2 X 2 1/2" X 7" | | (g) HANDLE | 1/2" X 1 1/2" X 1'-8" | STEEL FLAT. |
| (d) HORIZONTAL | 1 X 2 1/2" X 6" | | | | |

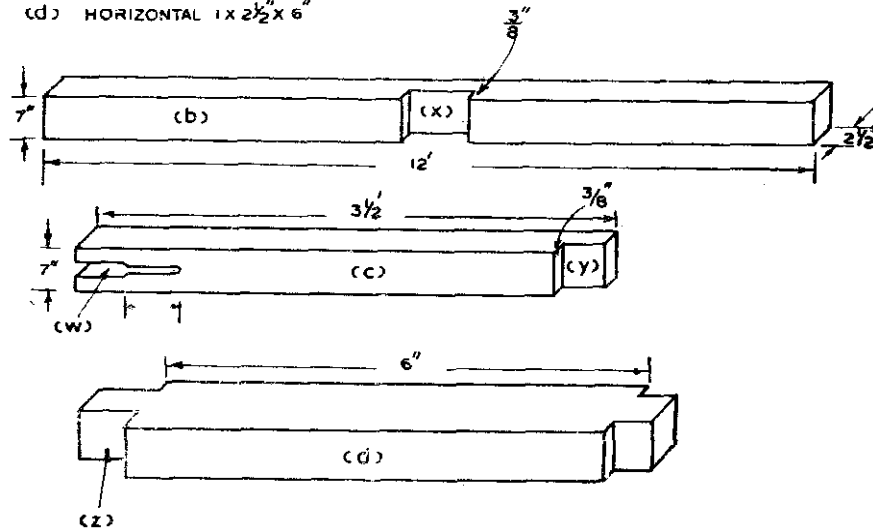

WELL DIGGING WINCH

WHEELBARROW

(Figures relate to Plates XXXVII, XXXVIIA, and XXXVIII)

Introduction : Wheelbarrows are quite suitable for Indian conditions where small loads of materials, needed for handling the earth work etc. are required to be transported to short distances. In India the most common practice for these situations is to employ women to carry head-load in baskets. These women suffer a lot of hardship as they have to carry heavy loads on their heads for long distances. It is necessary, therefore, that wheelbarrows should be introduced which would help in carrying comparatively larger loads much more efficiently and effortlessly. The wheelbarrow described below was invented in China and introduced in Europe in the middle ages. The particular features of merit include :

1. The use of a larger diameter wheel to reduce rolling resistance and improve comfort on rough roads.
2. Disposal of the load round the wheel so as to reduce the load on the driver.
3. The use of a shoulder strap running diagonally across one shoulder from one handle to the other, in order to lessen the strain on the arms.
4. A single wheel is easy to use on rough grounds and narrow paths.
5. Pneumatic tyres can be used but if a pneumatic wheel of suitable dia. is not available, wooden wheels can also be used.

Method of construction : The method of construction has been clearly shown in the diagram. This wheelbarrow can be made with wood planks, timbers and ropes. A brake has also been introduced so that the driver can operate it at down gradients or at other places where the speed has to be suddenly reduced. The design of the brake can also be used in hand carts.

A simple wheelbarrow, generally used in India is shown in Plate XXXVIII, with dimensions which can be easily manufactured by blacksmiths in the rural areas.

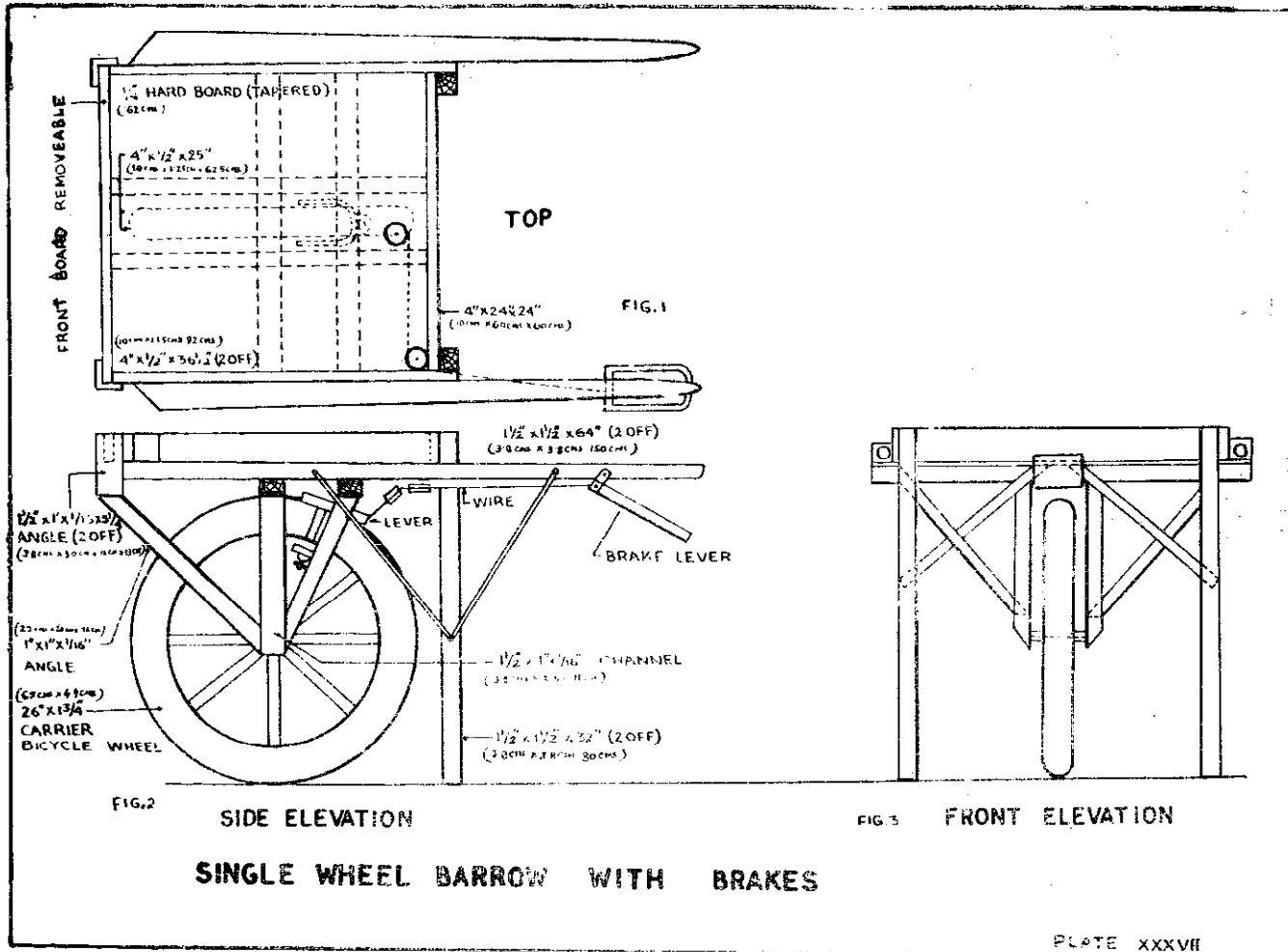

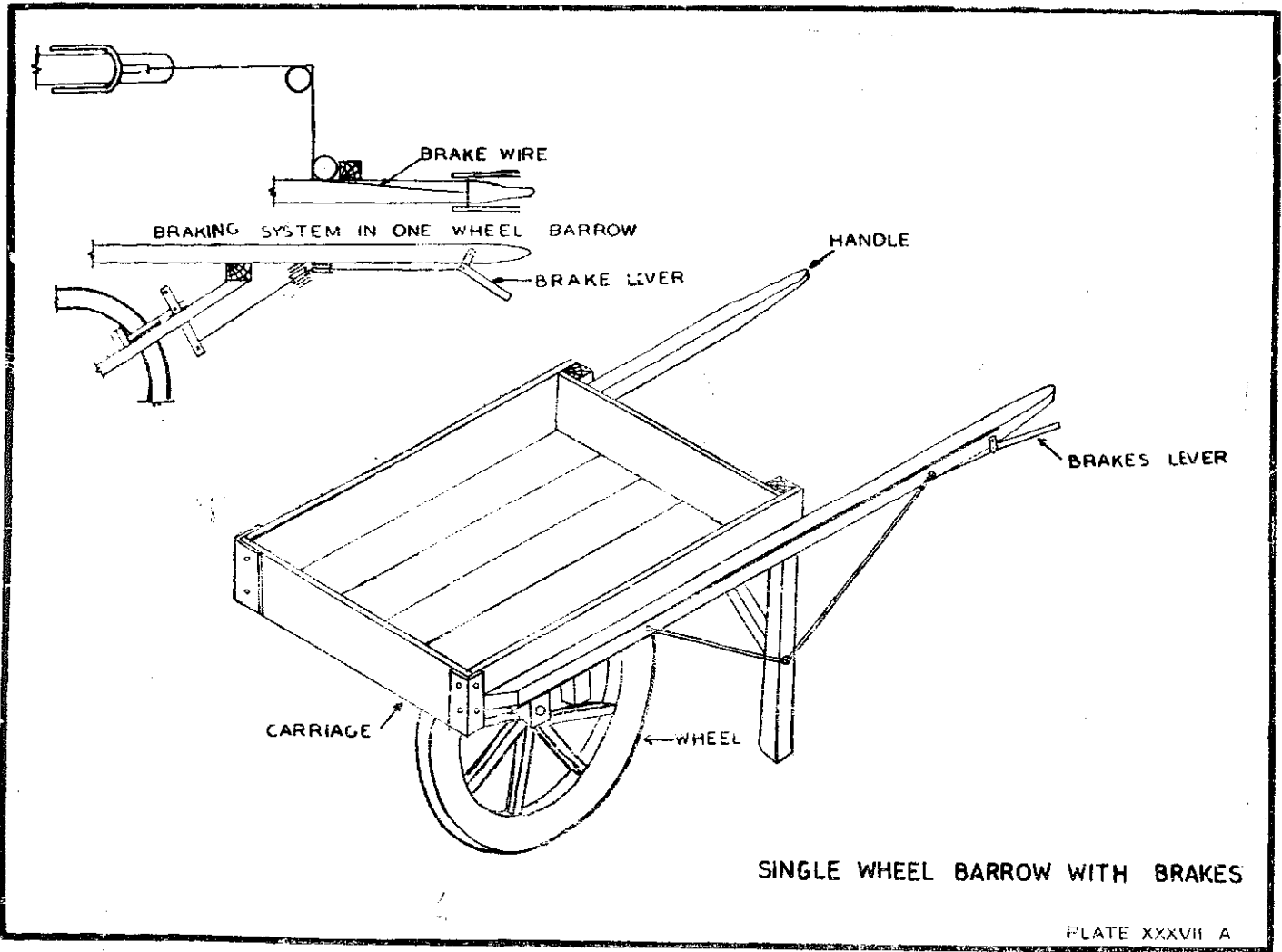

SINGLE WHEEL BARROW WITH BRAKES

PLATE XXXVII A

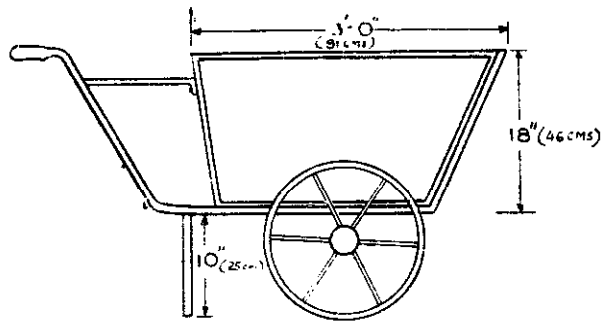

ELEVATION

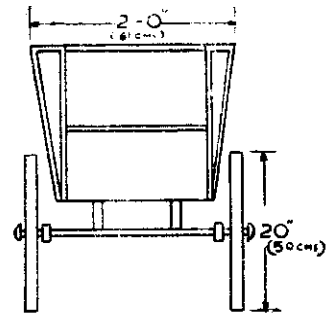

SIDE VIEW

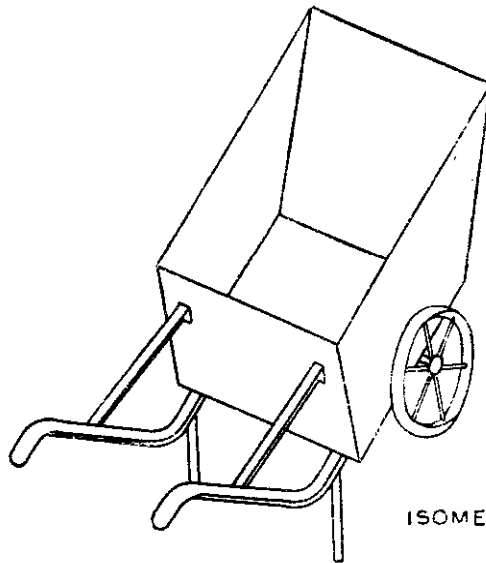

ISOMETRIC VIEW

WHEEL BARROW

THREE GEARED CYCLE RICKSHAW

(Figures relate to Plate XXXIX)

Introduction : Cycle rickshaw is a very important means of transport for medium and small towns. It is spreading in villages as well. It carries middle class families from one place to another at a moderate charge. Unfortunately rickshaw drivers have to work hard specially on up gradients. The braking system is also very defective and is sometimes responsible for serious accidents, injuring the drivers and damaging the rickshaw, sometimes beyond repairs. Any attempt to put on an engine on the rickshaw increases both its initial cost and running cost beyond the reach of poor people. The Appropriate Technology Development Association experimented by providing a three-gear hub and improved the braking system, which considerably improved its performance, without much increasing the cost.

Construction

(1) Take any three-gear hub attachment sold generally in the market for bicycles. Fix the hub to a specially designed bracket fitted underneath the frame of the cycle rickshaw as shown in Fig. 1 and 2. One chain is attached from the pedalling gear to the larger gear of the hub. Another chain is fixed from the gear to the rear axle.

(2) Fix a pedal in the front frame of the rickshaw with cables attached to all the three wheels, which are provided with braking systems. The hand-brake system used in the motor cars can also be used. Once the pedal is pressed, all the three wheels come to rest simultaneously, bringing the rickshaw to a stop in a very short time.

How to operate

(1) Cables with marks in the handles are provided to operate the three-gear hub. The rickshaw is started on the first gear, which moves the driving gear rapidly but the rear axle gear slowly, thus increasing the torque, and reducing the effort. The same gear should be used on up gradients. Once the vehicle has gained some speed, the second gear should be applied. When the normal speed is gained, the top or the third gear should be used.

(2) To apply the brake, press the pedal in front by foot slowly and gradually. Release the pedal, when the vehicle comes to a rest.

Price

			Rs.
(i) Three-gear hub attachment	160.00
(ii) Brackets	10.00
(iii) Brake cables, pedal, etc.	50.00
	Total	..	<u>220.00</u>

An increase of 22% on the current price of rickshaw.

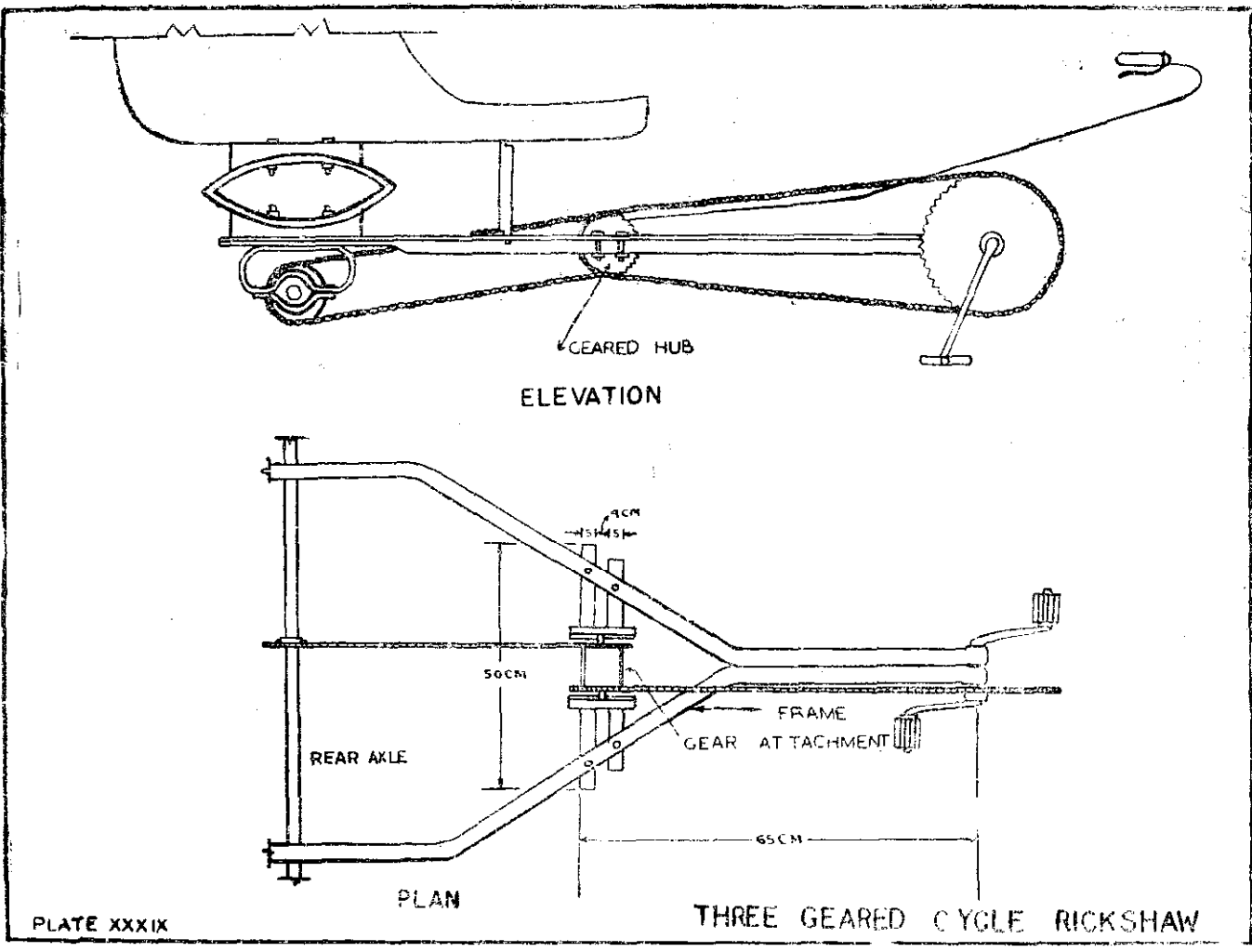

PLATE XXXIX

THREE GEARED CYCLE RICKSHAW

BULLOCK CART

(*Figures relate to Plate XL*)

Contact Agencies : 1. National Institute of Management, Bangalore.
2. Maulana Azad College of Technology, Bhopal.

Introduction : The bullock cart occupies the most important place for the transport of agricultural and other commodities in the rural areas. It is estimated that their number is about 13 million in the country and they account for more than two thirds of the total haulage in the countryside.

There are about 300 designs of the country carts driven by one or two bullocks as the case may be. Sometimes three or four bullocks are used for the haulage of heavy loads in carts. Of late, improved carts with pneumatic tyres are coming into use which can carry 3 to 4 times the load with one pair of bullocks as against the traditional carts. Since the latter have iron tyres fixed on the wooden wheel, they exert heavy strain on the bullocks in pulling, and damage the metalled roads.

A number of agencies—government and voluntary—are doing experimental and research work for improving the efficiency of the bullock carts; but no generally accepted model has been designed so far. It is understood that a committee has been recently appointed to examine the whole thing and recommend suitable measures or modifications which can be worked upon and the efficiency of the cart be improved. A number of improvements have been suggested by some agencies but as pointed out by Mr. Ramaswami of Institute of Management, Bangalore, though the cart looks simple, the technology is not so. A great deal of design effort is required to use suitable materials and design to arrive at different kinds of models for village roads, district roads and highways, to reduce the weight of the cart but at the same time not to impair its strength. The design must also take into account the different kinds of products they would be required to carry. The animal itself has to be studied to estimate the load it can carry and to improve the harness so that the animals' load-carrying capacity can be increased. Maulana Azad College of Technology, Bhopal has also designed a bullock cart, (Plate XL), and will soon be ready for testing in field conditions. The essential features of the designs which may bring improvement over the traditional carts are :

- (i) Lighter weight, which makes the bullocks carry extra load
- (ii) A special load bearing truss, with shock absorbing mechanism
- (iii) Special bearings
- (iv) Special attachment to yoke
- (v) Gunny bag pouch-fitted with straw attached to yoke, for the comfort of the bullock's neck and shoulders.

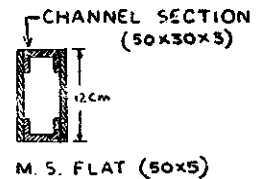
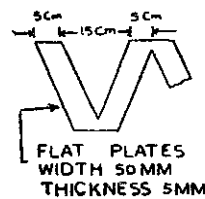
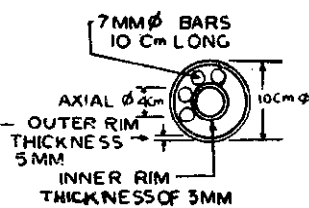
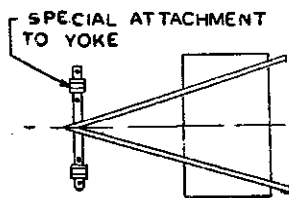
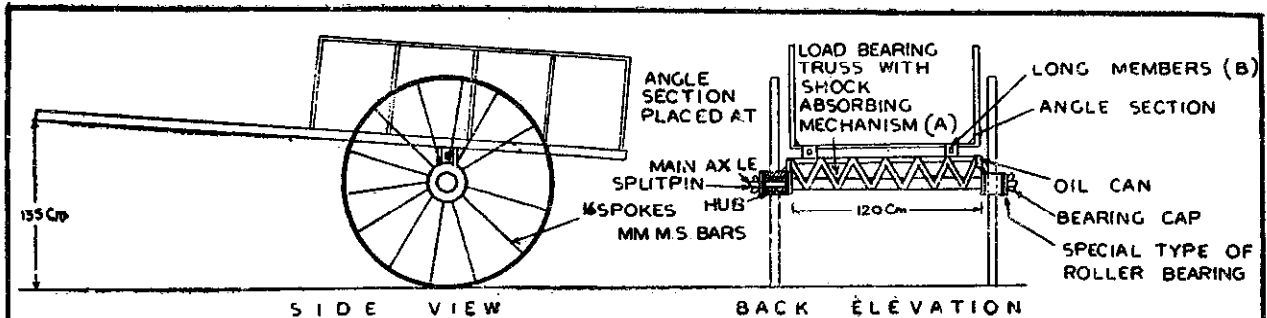

DETAIL AT A

POUCH MADE OF GUNNY BAG FILLED WITH STRAW FOR THE COMFORT OF BULLOCKS ATTACHED TO YOKE



CAGE FOR FIXING UP ROLLERS

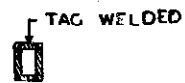

UNEQUAL ANGLES (50x30x3MM)

DETAILS OF BULLOCK CART

DETAIL AT B

BULLOCK CART DESIGN

Health and Hygiene

INTRODUCTION

Health-care is not only curing diseases but also preventing diseases, improving sanitation, giving nutritive food and instructing the people in the art of a clean and healthy life. It is difficult to provide expensive medical care to the poor people of the villages but it is not difficult to improve the environment of their living by cooperation and participation of the people themselves and bringing awareness for a clean and healthy living. The village vaid, hakims, midwives and others can be trained and equipped to render better medical service to the people.

This section deals with some of the healthy practices which could be adopted in the village areas, by installing sanitary latrines, giving clean and safe drinking water, organising a rural health scheme, recording weights of the babies regularly, etc.etc.. There are other methods and practices which can be introduced in villages. They can be categorized under appropriate technology for health and hygiene. They can greatly improve the health and life expectancy of the masses with little additional expenditure.

SANITARY LATRINES FOR VILLAGES

(*Figures relate to Plates XLI, XLIA, XLIB, XLIC, and XLID*)

Contact Agency : Friends Rural Centre, Rasulia, District Hoshangabad, M.P.

Introduction : Rural environments, particularly the adjoining fields bordering the villages, are greatly polluted as the local inhabitants defecate in the open. They become a medium for the breeding of flies, disease, germs and insects and are thus responsible for health hazards to the people. During the rainy season, things get still worse as the soaked cow-dung on the one hand and the night soil on the other produce foul smell, increasing the fly population which brings, in gastro-intestinal diseases and cholera taking a heavy toll of lives. Things are a bit better where pit latrines are used; but in the case of service latrines, conditions are quite appalling. A number of agencies have done considerable research and experimental work on rural latrines and have developed some designs which are acceptable to the villagers. Their installation is reasonably cheap. Friends Rural Centre, Rasulia and Planning, Research and Action Institute, Lucknow are particularly noteworthy for bringing home the idea of setting up sanitary latrines in the villages.

Plastic mould for sanitary latrine : The Rasulia design provides a good method for village people to cast their own latrines. A plastic mould is used for this purpose. The various parts of the mould are shown in Fig. 1, 2, 3 of Plate XLIA.

The outer part is made from two moulded pieces of plastic which are permanently fastened together with a piece of folded plastic strip down the sloping side, (Fig. 1), and bolted on. Two similar strips along the opposite side complete the outer mould. These two strips are removable.

The inner part is also made from two parts, the bowl and the trap part respectively. (Fig. 2).

The inner and outer parts of the mould are held together in their proper relationship by 12 roofing bolts; ten along the bottom rim of the bowl part and two through the case of the trap part. (Fig. 3).

The method of casting the latrine with the help of the mould is described below.

Casting the sanitary latrine

(*Figures in the following portions relate to Plates XLI and XLIB*)

A stiffener is used to provide additional support to the inner mould which is shown in Fig. 1 of Plate XLI. Remove the larger part of the inner mould and half bury it in sand in horizontal position. Mix about 9 litres of concrete using one part of cement to two parts of sand and three parts of 3/4" large stone chips and mix with enough water. Fill the hollow of the mould completely with this mixture to the level of the rim and vibrate it a little to remove any air bubbles. Allow this to set for at least 24 hours. Remove the 'stiffener' casting by inverting the mould and lifting it off carefully.

Latrine bowls : The latrine bowls are then cast in the following manner in a shaded place. Lubricate the inside of the outer mould and outside of the inner mould with cooking oil. Assemble the mould and place it over the

stiffener. Mix thoroughly six litres of clean dry coarse sand with three litres of fresh cement. Add enough water to make it pasty. Fill the mould through the hole at the top while tapping the sides with the hand to make sure that the mixture fills the mould and that air bubbles rise to the top. (Fig. 2). Allow the cement mixture to set for 24 hours.

After 24 hours remove the two bolts which hold the trap part, grip the rim and pull this part down with a steady pull. (Fig. 3).

Remove the ten bolts from the base rim after lifting it off the 'stiffener' and placing it on its side. (Fig. 4). With the mould and casting supported so that the hollow is facing sideways and up, lift out the inner 'bowl' mould. This is helped if several small wooden wedges are placed between the inner and the outer moulds on both sides. Gently push in the wedges one after another, first between the inner and the outer moulds, and then between the inside mould and the edge of the casting. Several pairs of wedges should be used to exert sufficient pressure on the mould.

Now carefully turn the casting with the outer moulds upside down so that the hollow part is on the ground. (Fig. 5 of Plate XLIB). Remove the two pairs of bolts from the two short plastic strips at the trap end and remove the two strips. Now grip the two parts of the outer mould and pull them apart to release the casting. The fresh casting is very soft and fragile and care is needed while it is being handled at this stage.

Immediately turn the casting the right way up and check the construction of the trap. This should measure 3" wide and 2" high, oval in shape. If the opening is too small it can best be enlarged with a tool made from a 7" x 1/2" bolt, the threaded portion of which is slightly bent. This is used as a rasp in the curved portion to remove any unwanted cement. (Fig. 6 of Plate XLIB). The finished bowl casting must be placed in water within 10 min. of removing it from the mould and left there for at least 7 days.

Casting plate : Oil the top of a very smooth casting plate and put a finished bowl upside down on this plate. (Fig. 7 of Plate XLIB), and place a rim around it. Four pegs on the outside will help to locate this accurately. Place a ring of 1/4" reinforcing iron around the bowl and pour in a mixture of concrete similar to that used for the 'stiffener.' Cover with damp sack or straw and allow to set for 24 hours. Lift off the casting plate and remove the steel rim. Keep damp for at least 7 days.

Installing water seal latrine pans

(Figures relate to Plates XLIC and XLID)

Standard water seal pan. (Fig. 1): This is mounted directly over the digestion pit. It is mounted on a place 38" dia. over kutchu pit. (Fig. 2). Ring of burnt brick is set in mud all round. Alternatively for a more permanent arrangement the plate is set over a pucca pit of brick laid floor. Space between brick lining and undisturbed soil is back filled with brick, bats, stone chips, cinders, etc. (Fig. 3). A similar installation using concrete well lining rings can be made. This is more expensive, but quicker and more permanent.

Special water seal pan with pipe spout. (Fig. 4): This type is useful inside a brick wall (pucca) building or for changing existing sweeper cleaned latrine to water seal. Digestion pit should be at least 3 feet away from the foundation of the building. (Fig. 5).

In both cases water is used in bucket to flush out.

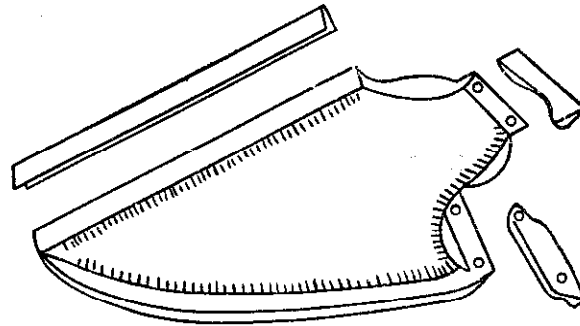

FIG. 1.

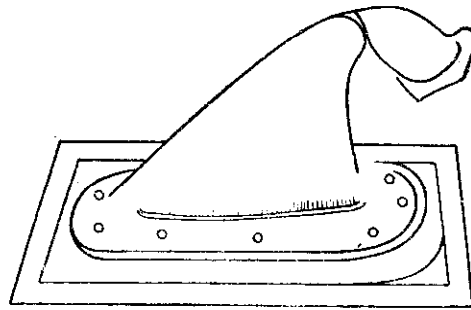

FIG. 2.

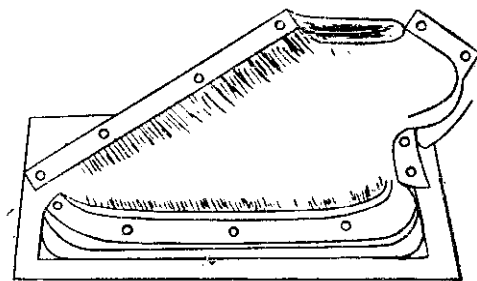
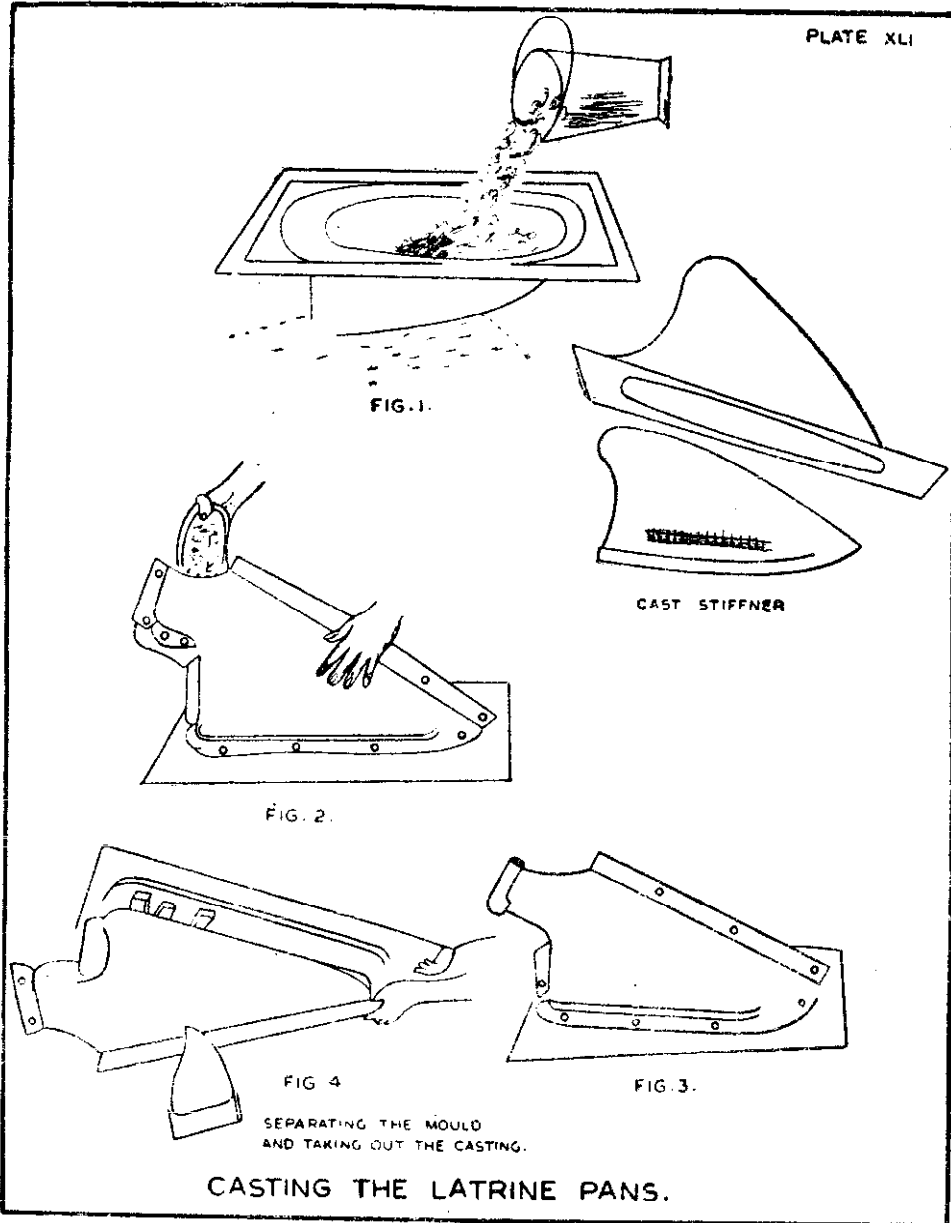

FIG. 3.

PLASTIC MOULDS FOR SANITARY LATRINES.



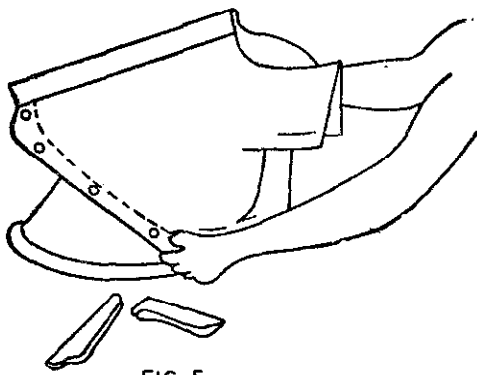

FIG. 5.

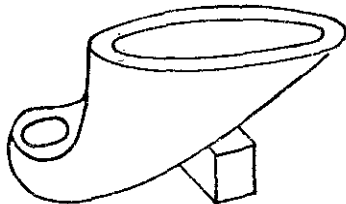
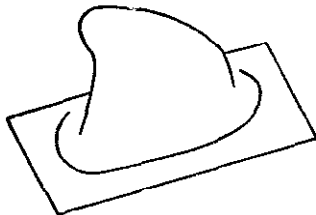

FIG. 6.

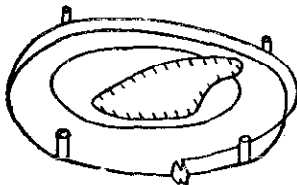

FIG. 7.

PLATE XL C

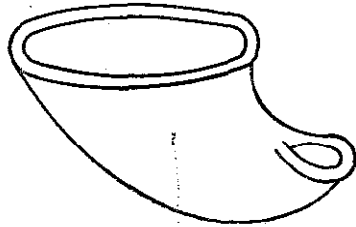

FIG. 1.

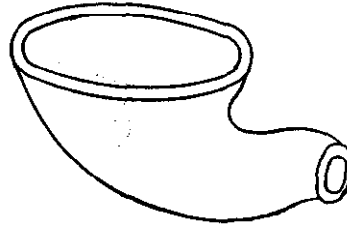

FIG. 4.

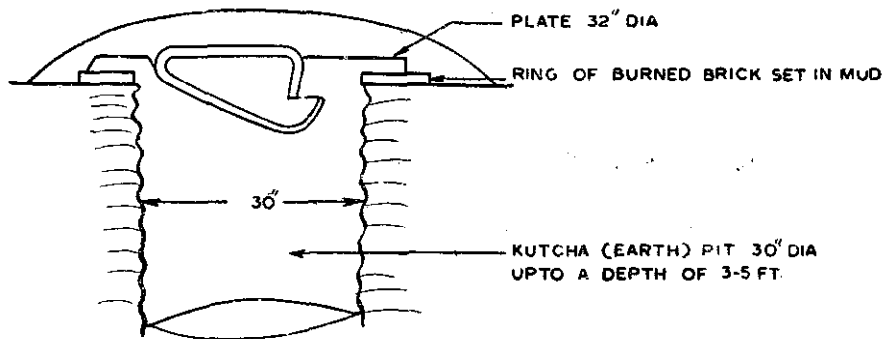

FIG. 2.

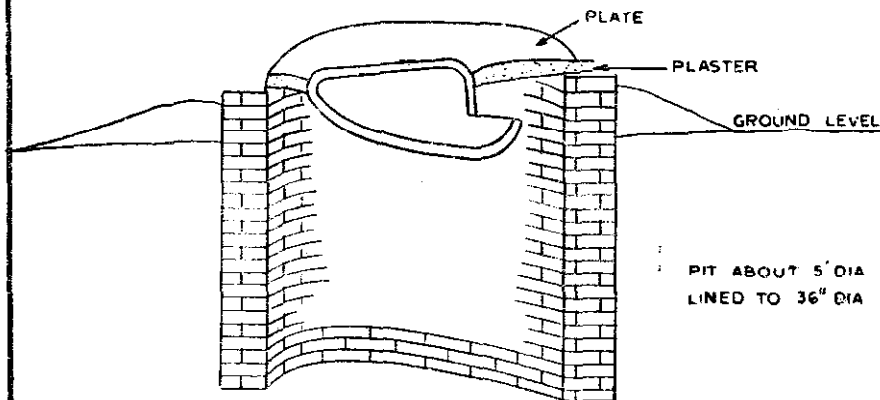
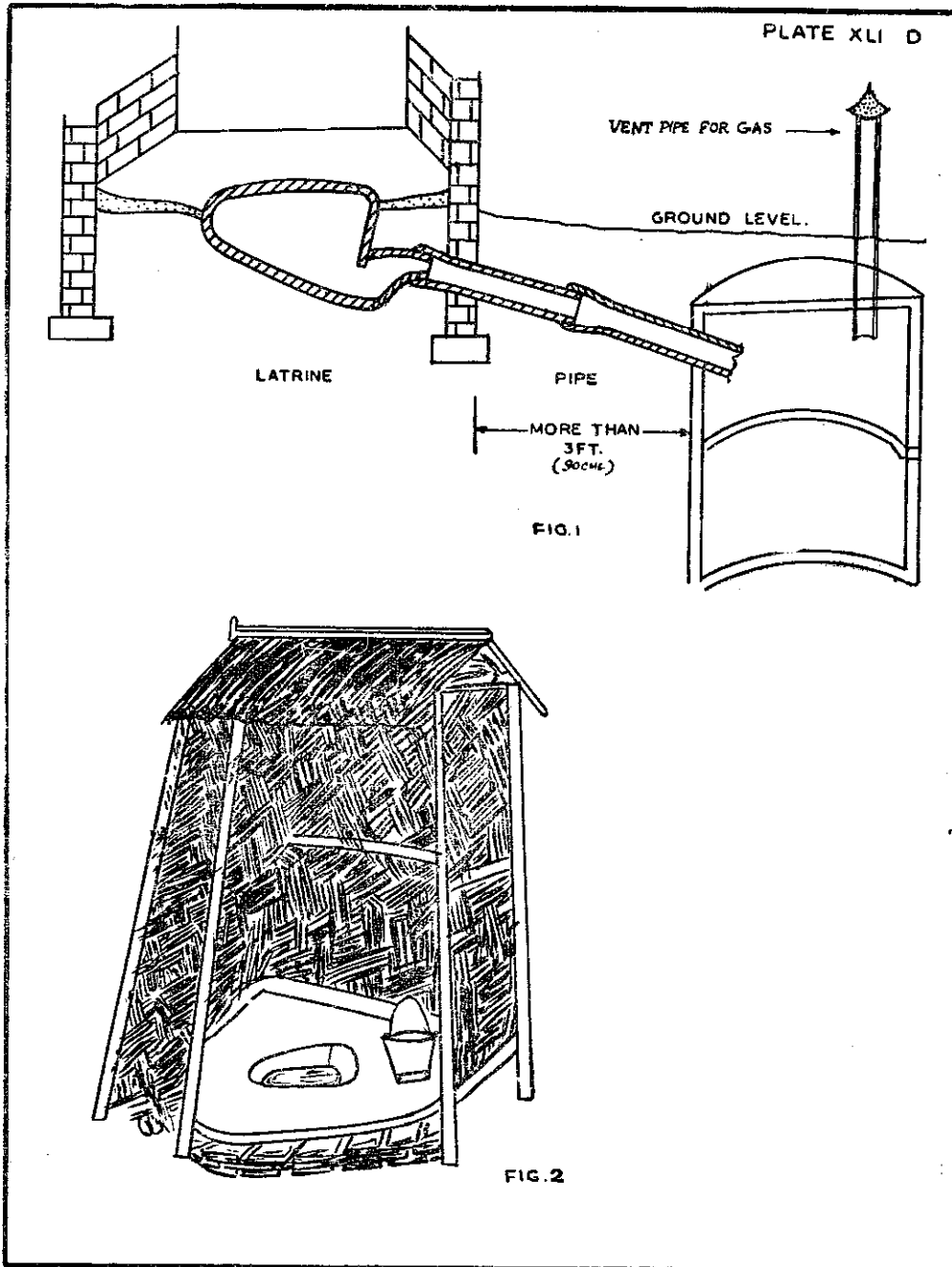

FIG 3

CONSTRUCTION OF THE LATRINE.



WATER SEAL LATRINE

(Figures relate to Plate XLII, XLIIA)

Contact Agency : Planning, Research and Action Divn., Lucknow.

Introduction : Latrines are great problem in the rural areas. One always finds the sight of men and women sitting in the fields, on the sides of the roads and ponds for easing themselves. Apart from causing inconvenience to villagers, it causes sanitary problem and spreads disease. Planning, Research and Action Division of Lucknow has designed a very cheap and effective latrine which can bring about a great change in the hygienic condition of the rural areas.

Location

1. Choose a site not flooded by rain, avoid location of pit near drain or spouts as the water may cause collapse of the pit.
2. Site the latrine as near the house as possible.
3. Do not site the pit nearer than 25' from a drinking water well.

Construction

1. Draw the plan of the squatting plate, pipe and pit on the ground to ensure proper location.
2. Dig the hole in the ground for pan and trap and place pan and trap in position with pan projecting 3" above ground level. Ensure that pan top is horizontal to form a good water seal in the connected trap.
3. Make a joint between the pan and the trap by placing the socket of the trap over the outlet of the pan and filling the space between them with cement mortar 1:1 (cement: morum). The joint inside should be smooth.
4. Wet and damp the earth firmly around the pan. Make the floor 3' x 3' around the pan in one course brick work set in cement mortar 1:4 (cement: morum) with $\frac{1}{2}$ " slope from outer edges to the pan. Plaster the top of the floor with $\frac{1}{2}$ " cement mortar 1:4 and form foot rests.
5. Connect extension pipe to trap filling in the space in the socket of the curved pipe with clay and plaster to break easily the joint when altering the pipe position to use a second pit. Only the outside is to be done with cement mortar. The slope of the pipe should be not less than 1" in every foot and project about 3" into the pit.
6. Dig the pit 2'9" in diameter and at least 8' deep depending on the kind of soil. Lay bricks in mud mortar around the top of the pit to support the pit cover.
7. Place cover on the pit. The top of the cover should be 6" below the natural ground level. Pack down 12" of earth over the cover and form a mound to drain the rain water away.
8. Construct the *purda* wall.

Use and maintenance

1. Wet the latrine pan before use.
2. Flush the pan immediately after use with one or two jugs of water.
3. Keep the latrine platform and pan always clean.
4. If the trap gets clogged, fill the pan with water, make a ball of cloth or gunny at the end of a stick and press the water with quick movements around the trap.

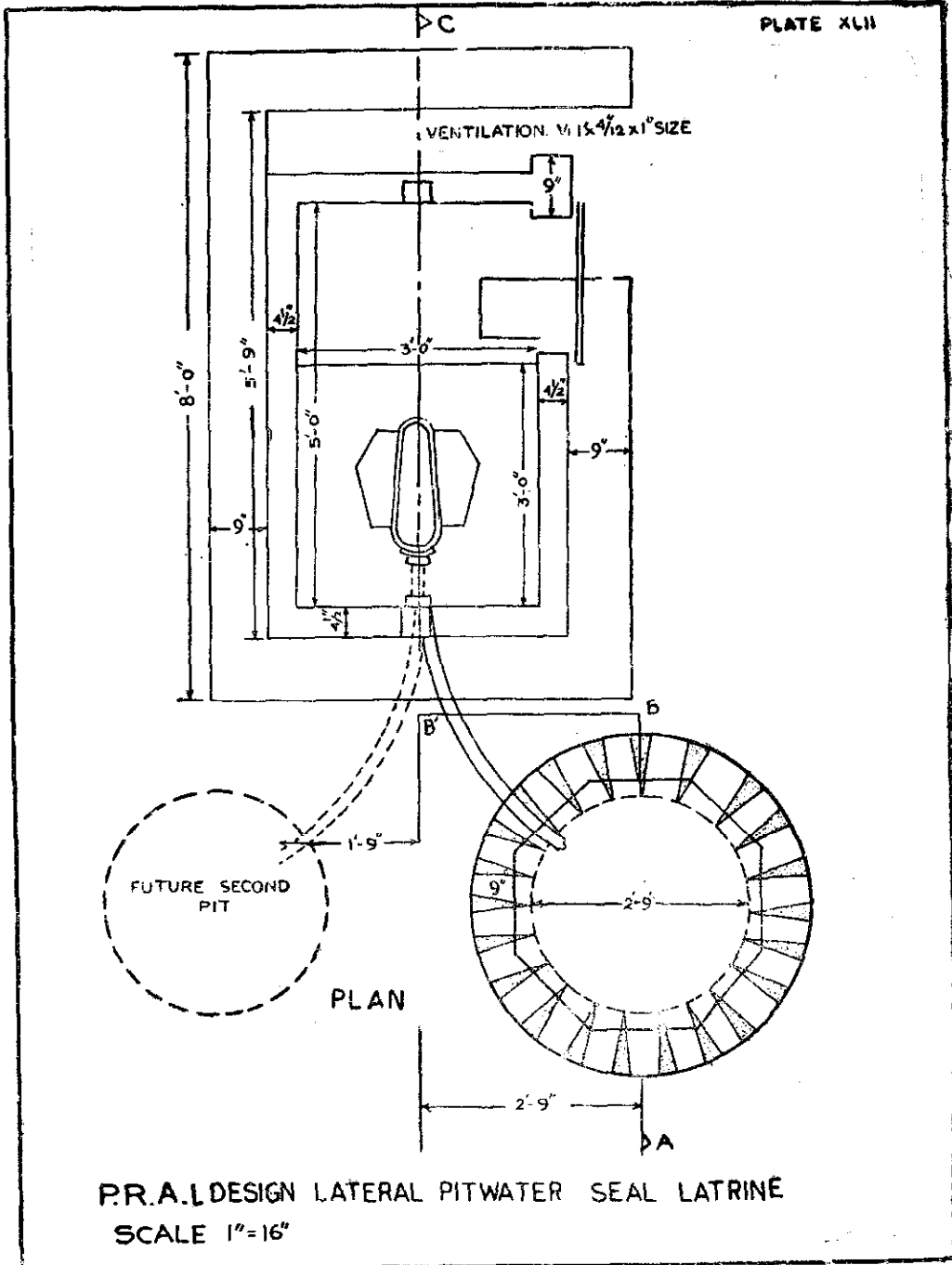

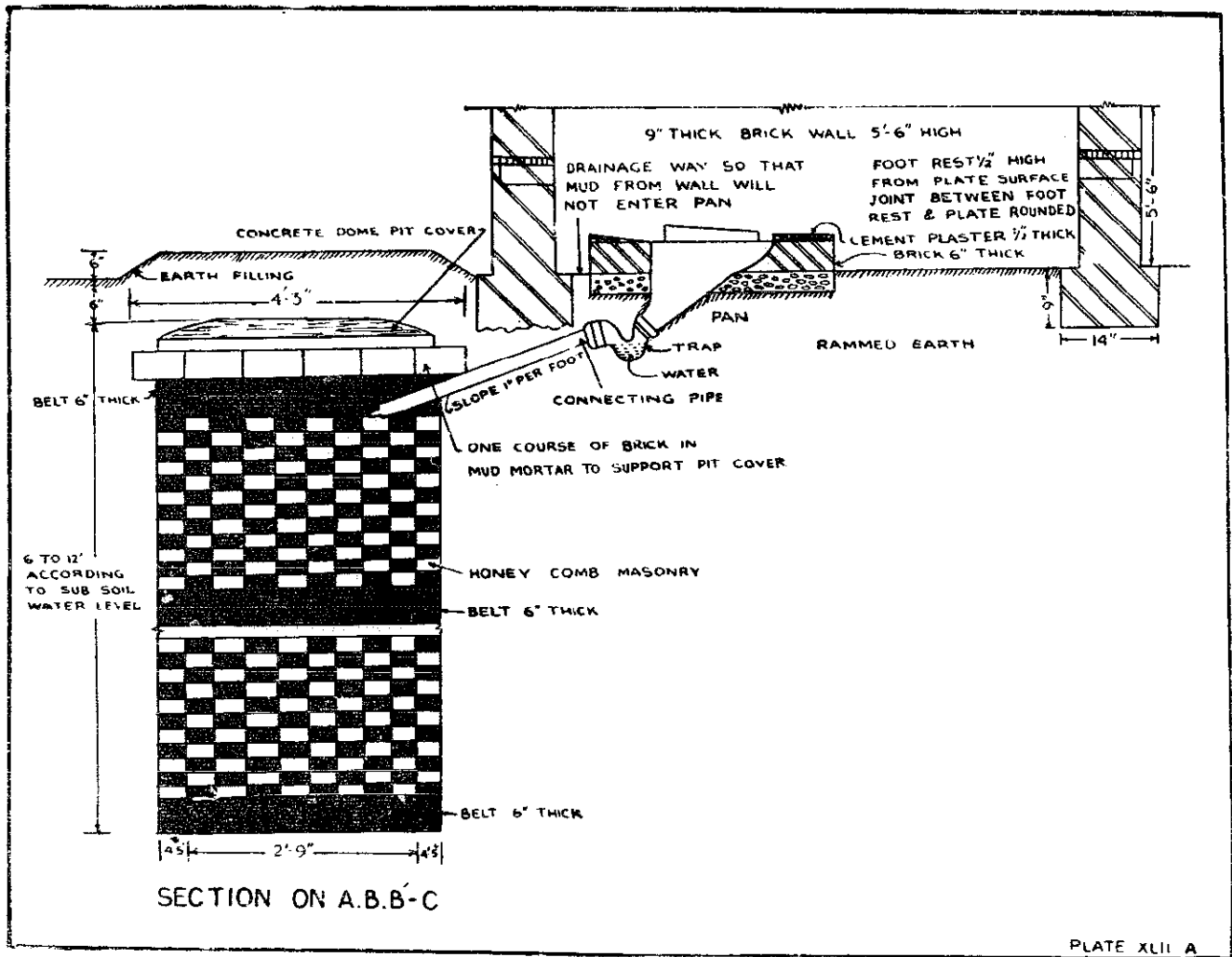

QUAC STICK

(Figures relate to Plate XLIII)

This is a device to check whether the children are malnourished or not. This is developed by Friends Religious Society's Relief Team and the name is derived from Quaker Arm Circumference. It is particularly useful in emergency situations, in a famine or drought area where a large number of children have to be examined and no elaborate medical checking facilities are available.

The chart shown in the figure is pasted on the wall and the children made to stand against it for measuring their heights. The mid-circumference of the upper arm of the child, with his hand hanging down is also measured. The arm circumference of the child against his height is compared. If it falls in the 85% mark, it means that his arm circumference is 85% of the normal circumference for the child of his height; similarly for the 80% mark and 75% mark. Below the 75% are seriously undernourished and are likely to need feeding twice a day with low bulk calorie and protein food. 75—80% require food supplements, while those above 85% are generally normal. An 80% or 75% line has to be fixed for determining the low nourishing standard.

As for example, if a child is 100 cm. tall, and his arm circumference is less than 12.5 cm., his nutritional rating is at 75%; if his arm circumference is more than 14.2 cm., he may be considered normal.

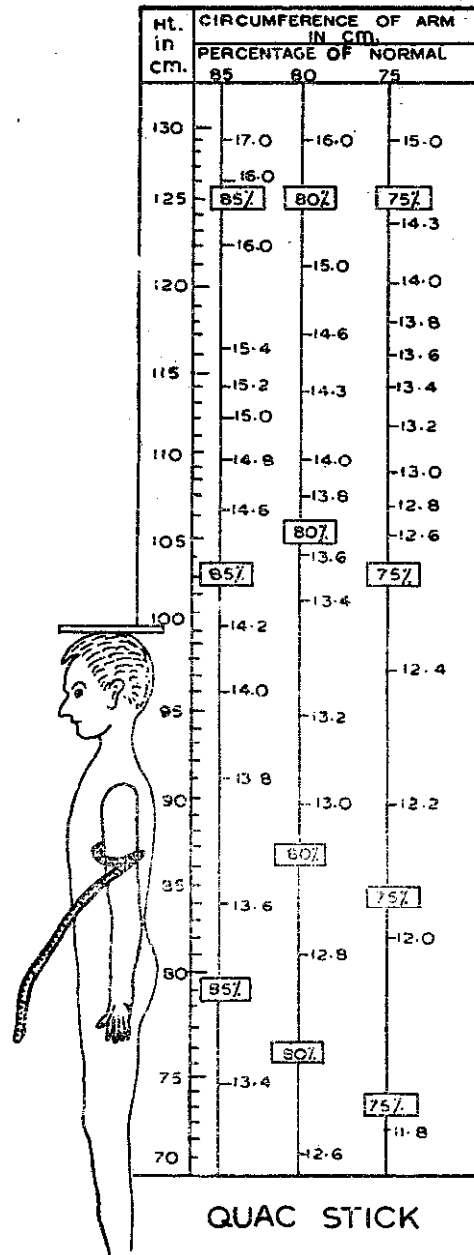

HOUSEHOLD FILTER UNIT

(*Figures relate to Plates XLIV, XLIVA*)

Contact Agency : VITA, Inc., 3706, Rhode Island Avenue, Mt. Rainier, Md., 20822, U.S.A.

Introduction : In rural and sub-urban areas common sources of water supply are shallow wells sunk in backyards, surface waters collected in earth dams, ponds, or drawn from streams. These waters are often subject to bacterial contamination and may be turbid. This equipment provides a simple purification and disinfection procedure suitable for individual households.

How operated

(a) *Disinfection*—Add $\frac{1}{2}$ tea-spoonful of calcium hypochlorite to 100 litres of drum water. Stir gently for 5 minutes. Smell for chlorine.

(b) *Sedimentation*—Add one table-spoonful aluminium sulphate or two table spoonful of potassium alum to 100 litres of drum water. Stir gently for 3 minutes until a sediment starts to form. Add one table-spoonful of calcium carbonate stirring continuously. Drain flock through tap B.

(c) *Filtration*—Tap C is opened and water flows on the splash plate until tank D is filled. With tap C open, tap E is opened to keep the level of water in D constant. Drinking water is drawn off through carbon filter H, and for other purposes from tap I.

Construction

(i) *Raw water container*—A drum or any receptacle A of about 100 litres or greater capacity is placed on a pedestal Z. Two taps are set in the drum; the first tap B, in the bottom and the second tap C, in the side about 10 cm. above the bottom.

(ii) *Sand filter*:—A clean kerosene tin D of about 3 to 4 gallons capacity receives water from tap C. Tap E, set in the side of D, just above the bottom of the tin, is connected on the inside of the tin with a perforated rubber or plastic hose of about 12 mm. dia. A layer of gravel of about 10 mm. average size surrounds the hose up to 100 mm. above the hose. A layer of about 30 cm. of clean river sand with average size grains of about $\frac{1}{2}$ mm. is placed on the top of the gravel layer. A splash plate of enamel or china is placed on the top of the sand.

(iii) *Clean water reservoir* : A covered container F, receives the filtered water. It has two taps, I and G, set in the sides near the bottom. Tap G, is connected to an activated charcoal filter H; tap I is used to fill pails or other receptacles.

(iv) A cylinder H of mild steel about 30 in. (76 cm.) in length and 10 in. (25 cm) in dia. painted on the inside with asphalt to reduce corrosion is filled either with activated charcoal or charcoal made from coconut shells. To prevent clogging of the connecting piping, the charcoal is placed between the top and the bottom layers of fibrous material such as palm fibre. Water from tap G is filtered through this container and the residual colour and taste are removed. The

charcoal filter is not essential to health; its use depends primarily on the desired degree of removal of colour, and on improving taste.

(v) *Other materials* : One mixing stick of bamboo or wood. One table spoon (10 gm.), one tea spoon (5 gm.).

(vi) Aluminium sulphate or potassium alum, calcium carbonate, calcium hypochlorite powder, activated charcoal.

Price : Can be manufactured from waste materials like petrol and kerosene drums with the help of village potters, blacksmiths and carpenters. This would cost approximately Rs.200.

The unit can be made more cheaply by using earthen vessels shown in the alternative diagram. (Plate XLIVA).

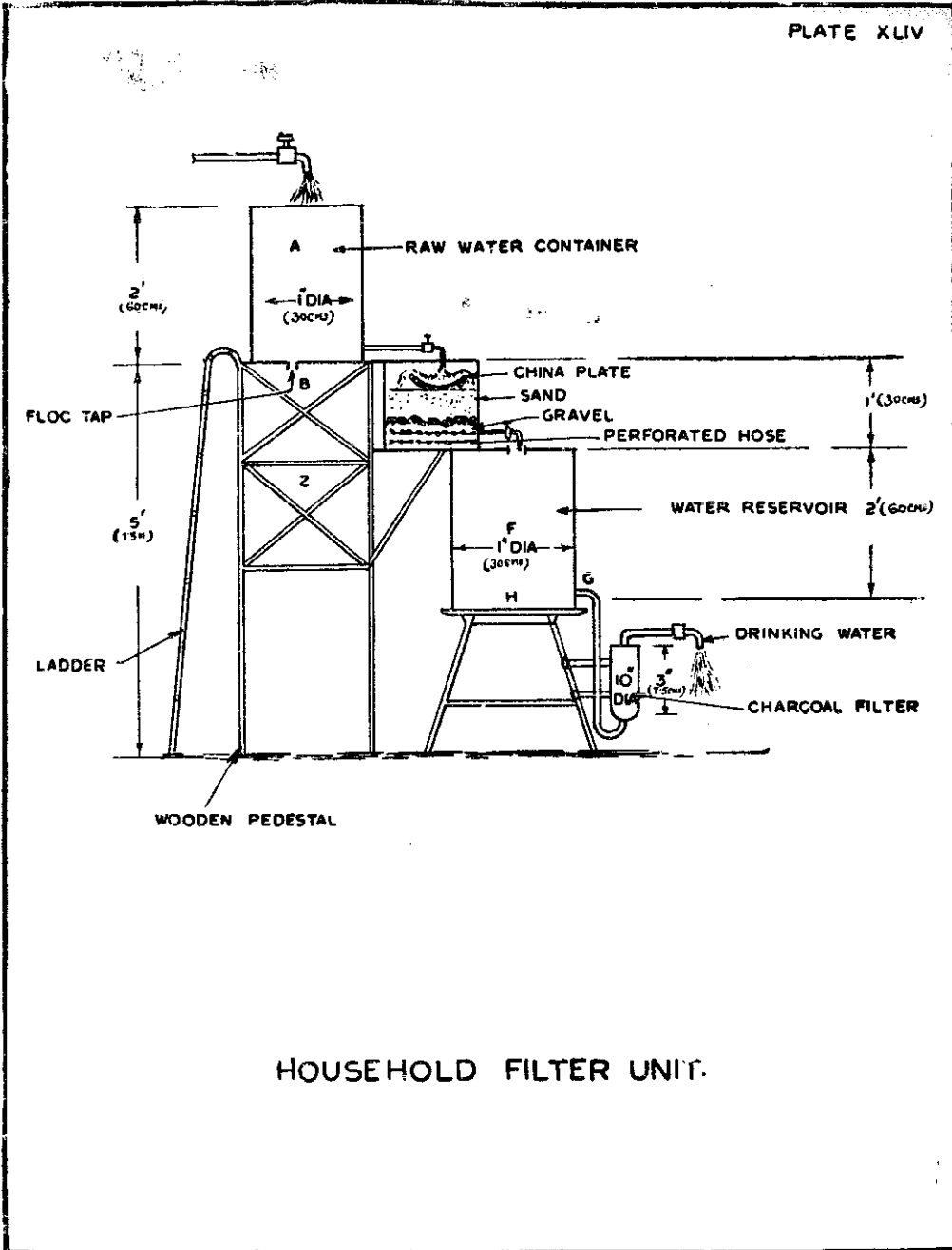

HOUSEHOLD FILTER UNIT.

PLATE XLIV A

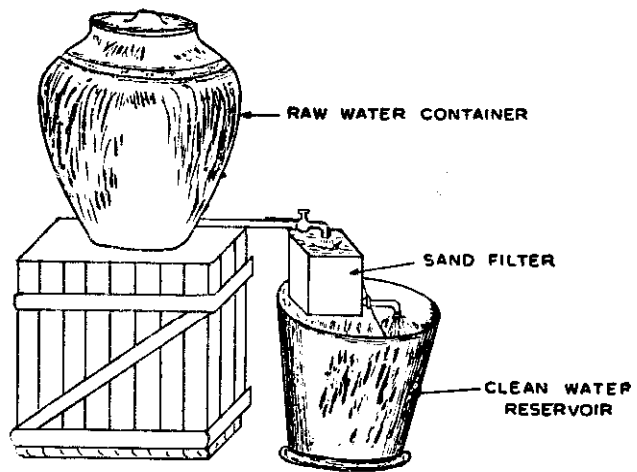

ALTERNATIVE CHEAPER UNIT.

CHILD WEIGHING EQUIPMENT

(Figures relate to Plate XLV)

Contact Agency : Intermediate Technology Development Group Ltd.,
9, King Street, London, S.W. 1.

Introduction : A handy equipment for weighing children is needed for health visitors and others to monitor the growth of babies. Generally, it becomes very cumbersome to weigh babies on ordinary scales. The equipment described below is designed in the form of a swing and attached to a spring balance. It can be hung on any tree or peg and readings of the weight of the baby easily obtained on the spring balance.

Construction : The equipment is designed in canvas, being very easily available, strong, easily washable and comfortable. Easily detachable wooden rods are used to make room. They are joined to the body by means of simple rings. The design can be further simplified by making a sort of cradle attached to a spring balance. Any tailor can easily make it.

How operated : The equipment can be suspended through the spring balance to any fixed structure on ceiling or on a branch of a tree.

Infants (under $1\frac{1}{2}$ years) can be laid on their back with the canvas completely open and supported by the rod.

Children over $1\frac{1}{2}$ years can be made to sit. In this case, the supporting rods can be let loose or can be used for gripping, if necessary. By lowering one of the side strings, the child can sit in riding position on the raised side canvas receiving well enclosed support to the back and a grip to hold which is provided by the front string.

Price : About Rs.20 including spring balance.

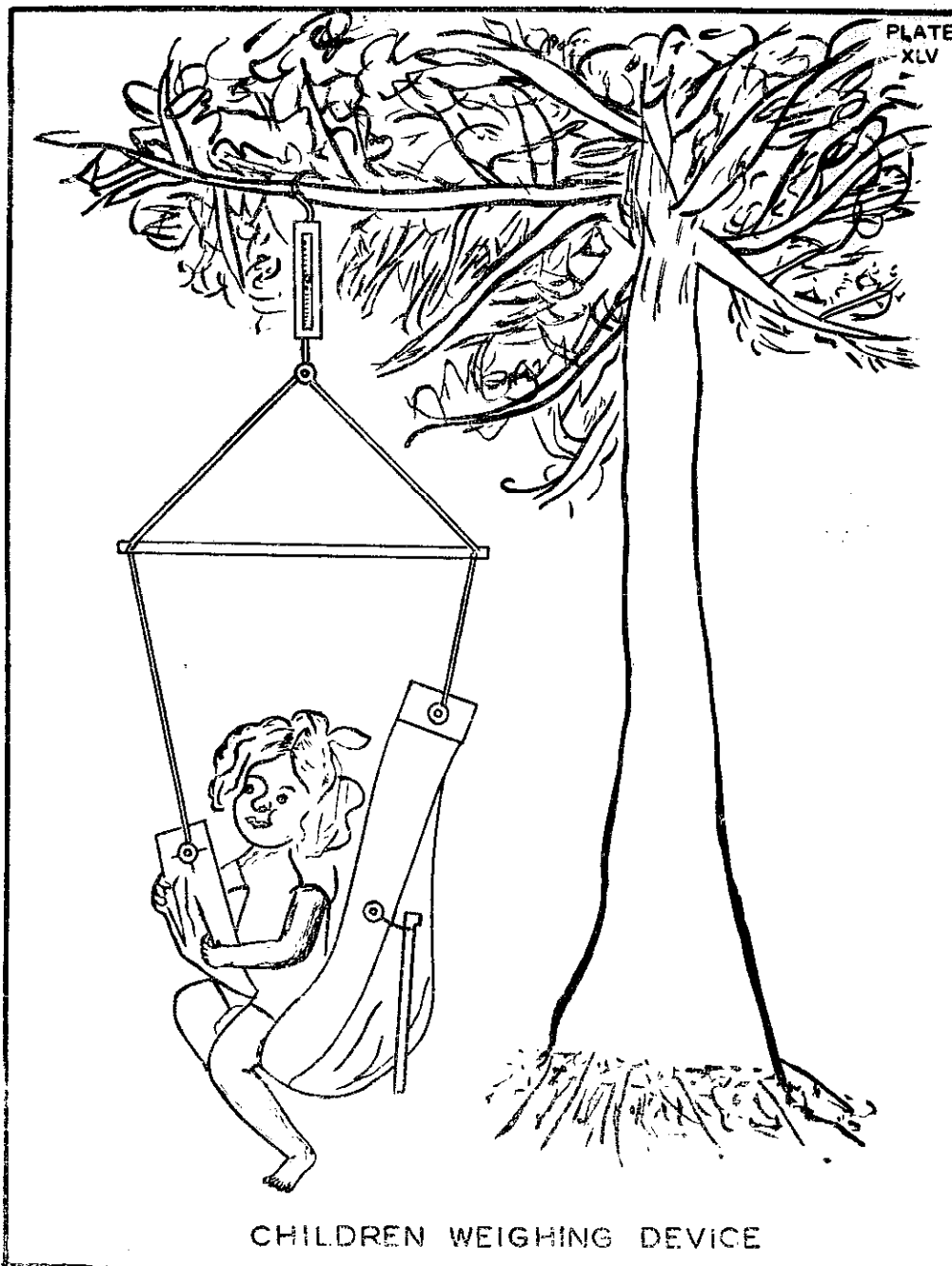

RURAL HEALTH CARE

(Figure relates to Plate XLVA)

Contact Agency : Dr. K. S. Sanjivi, Professor Emeritus in Medicine,
Shantam, Perugudi P.O., Madras-600096.

Introduction : The health care scheme for the rural areas should be simplified to cover as wide an area as possible. It should include environmental sanitation, personal hygiene, preventive treatment, minor day-to-day illnesses, major illnesses and accidents. The Voluntary Health Services (VHS), was started by Dr. Sanjivi to focus attention on these subjects and to develop a concept of community health care in the rural areas. It is comprehensive in coverage, provides continuous and permanent service, and relies mostly on cooperative principle, rather than on mobile units or ad-hoc camps. In the three years of its operation in the rural areas, it has been able to train poor medical workers to man rural health posts and has worked out a model for ensuring part time co-operation from the local medical graduates to work in their mini-health centres. It has covered over 15,000 families comprising nearly 75,000 persons served through 16 mini-centres. The scheme appears to be an ideal one, being easily extendable over large areas, costing well within the reach of the weak and poor communities. It promises to present a basis for the integration of community health care, family planning and nutrition in the rural areas, and for the integration of voluntary effort with government work.

The Scheme : The model suggested by the V.H.S. is roughly shown in the diagram in Plate XLVA, which indicates the possibilities of a para-health medical service around health posts operated by Lay-First Aider (LFA), who live in and belong to the community. The LFA is the most peripheral body linked through mini health centres to the block public health centres and taluka hospitals. There should be one male and one female para-medical worker at the sub-centre or the mini centre and a higher type of supervisory staff, one male and one female, for every 20,000 population; or each to supervise four workers.

The scheme required the families to pay for health care as they have to pay for food, clothing, shelter, education, etc. This would instil a sense of respect and importance for the health care. A mini health centre covering 1,000 families would cost Rs. 18,000 per year. It was worked out that 0.5% of the annual income coming from every family, with a minimum of 50 p. per month or Rs. 6 per annum could completely take care of community health programme. One-third cost was to be borne by the beneficiary families, one-third by the state government and one-third by the central government. This payment is put into a single chest, called Community Health Delivery Corporation (COHEDEC) and the services channelised through a single delivery channel of Mini Health Centre. The central government, the state government, the industrial or commercial employer, the panchayat, the self-employed individuals are expected to provide the financial inputs on this basis.

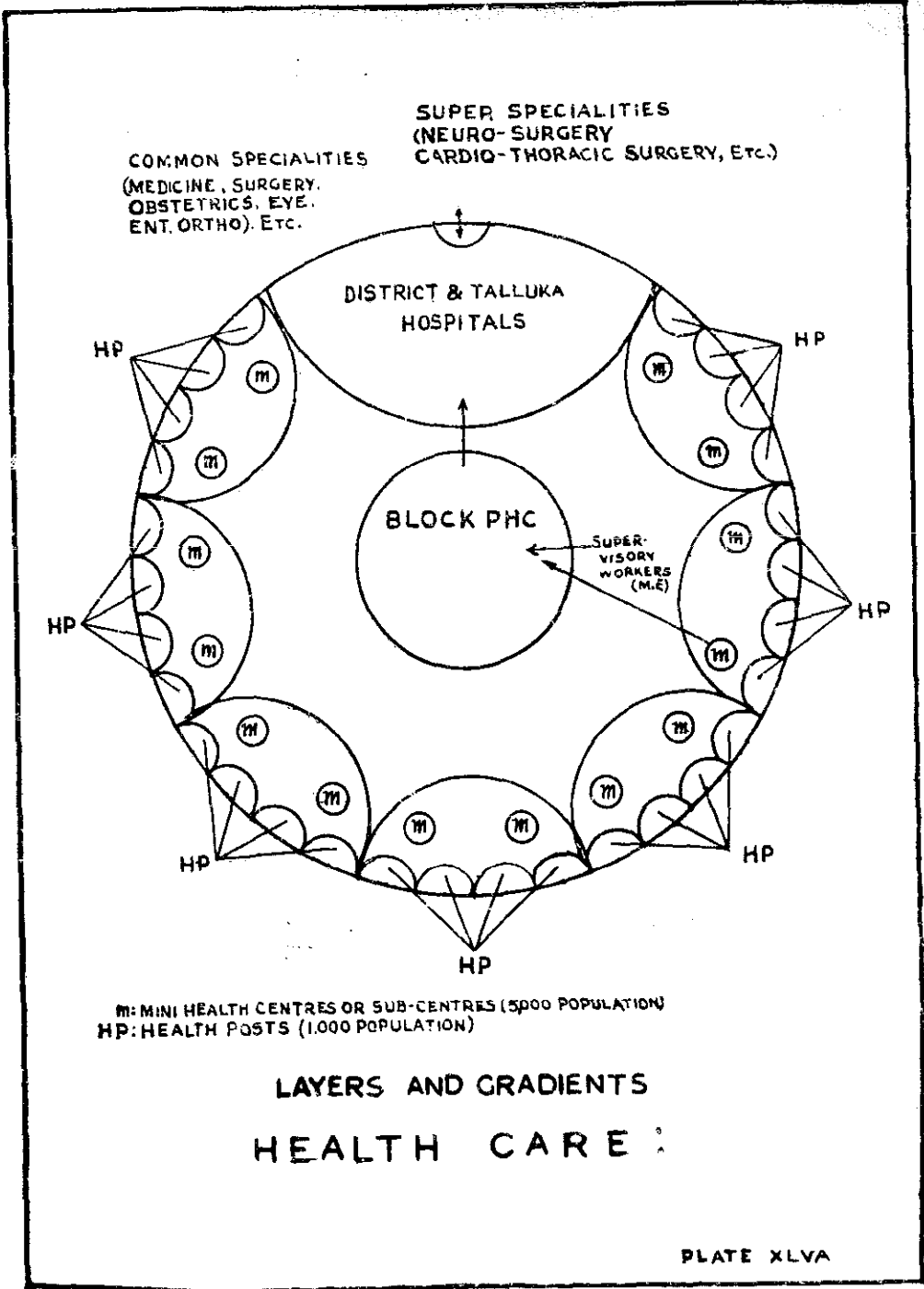

10/10/10 10:10:10

Education, Training, and Culture

INTRODUCTION

The best purpose of education could be to make an educated person able to improve his environment, in addition to making his own attitude scientific, liberal and unsuperstitious. Unfortunately, education in this country for a variety of reasons, has not been oriented towards meeting the existing needs of the country. The educated persons tend to desert their rural environment, instead of improving them. They mostly look for white-collar jobs available in urban areas and hesitate to take up jobs which require manual labour. This notion is transmitted to a great extent from their elders.

The concept of appropriate technology envisages an education which should develop suitable skills in the educated persons, so that they are able to do productive jobs in a better way, more efficiently and with higher productivity. Most of the village crafts, from ancient times, like blacksmithy, carpentry, leather work, pottery, weaving, handicraft, etc. have been coming down in a hereditary manner with the result that the children pick up skills in these crafts in the ordinary course without any formal training. The modern education, however, is weaning these people away from their traditional crafts and taking them to white-collar and unproductive jobs or to urban based large scale industries. After some time, these skills, abundantly available in the villages of India at present, would disappear, if something is not done drastically with our educational system. If education and training were imparted to the people in their traditional family crafts with modern scientific knowledge and improved equipment, they would be able to do their work in a more dignified and respectable manner with greater productivity and efficiency and thus contribute greatly to the national wealth of the country.

Cultural life is also very important for the villagers. This gives the artist an opportunity to express his inner feelings and sentiments. For this purpose, new techniques and methods of cultural entertainment should also be developed in a manner that they are inexpensive but are at the same time effective and simple.

This section deals with some of such ideas and methods.

LOW COST MICROSCOPE

(Figures relate to Plate XLVI)

Contact Agency: Community Science Centre, Ahmedabad

This microscope, developed by Community Science Centre, Ahmedabad, gives a magnification of 1:60. A firm at Bangalore is manufacturing the instrument on a commercial scale and has priced it at only Rs.15.

The object to be viewed is kept on a slide on stage C. The focussing is done by means of knob A. The lens is fitted in cap D.

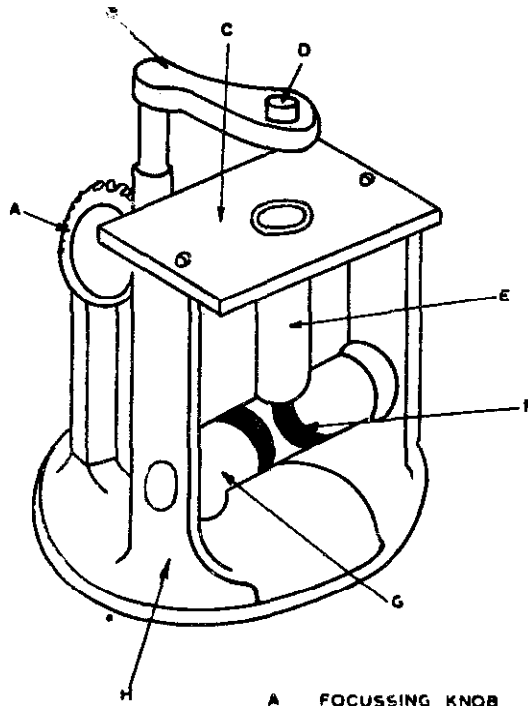

- A FOCUSSING KNOB
- B LENS HOLDER
- C STAGE
- D LENS CAP
- E STAGE TUBE
- F MIRROR
- G STAGE SUPPORT
- H BASE

MICROSCOPE

SOLAR STILL

(Figures relate to Plate XLVII)

Contact Agency : Central Salt and Marine Chemical Research Institute,
Bhawanagar-2 (Gujarat).

Introduction : Water is a basic need of life. It is estimated that only 90% of the Indian villages have perennial drinking water facilities. The water deficient areas are mostly located in arid and semi-arid regions. In many cases, some areas lack good quality water, but are rich in underground or surface saline water which is unfit for human consumption. It is possible to use solar energy to evaporate and distill water in solar stills using the same water cycle which is responsible for the rainfall or natural precipitation.

The saline or brackish water is converted into pure, fresh water by natural distillation operation and the resulting product is a good quality distilled water, which can be used in isolated places like light houses, salt farms and in laboratories for routine analytical work and for battery (acid lead accumulator) charging purposes. The water can also be used for drinking after adding some necessary salts and minerals. The solar energy is free and there is no maintenance cost. Production of distilled water by solar stills can also form a small scale rural industry.

Construction

The main design of the still is a masonry construction on which glass roofs are provided on two sides. Clean glass covers offer good surface for rain water collection. On the sides of the masonry construction, drains of aluminium channels are provided all round. The drains are maintained in clean and immaculate condition. At the lowest portion of the drain an outlet pipe is provided which takes distilled water to a flask or other collecting appliances.

How to operate : Brackish or salt water is stored in the tank provided in the centre. Sun rays, going through the glass covers enter the still and evaporate water in the central tank. The vapours thus produced rise up and come into contact with the inside of the glass surface and condense and trickle down the inside surface. Eventually they drop into the aluminium channel drain and collect in the collecting devices. The average output is about 2 or 3 litres per sq. meter per day depending upon the sunlight.

Further information : Large sized solar stills are erected on the sites as it is difficult to transport the assembled units. Central Salt and Marine Chemical Research Institute helps interested parties in setting up their own solar stills by supplying designs, drawings and other necessary information and the interested parties can erect their own stills.

Approximate costs are as follows :

				<i>Design</i>	<i>Construction</i>
				Rs.	Rs.
1—5	litres /day	25	60—100
5—10	„	50	200—300
10—50	„			100	300—500
50—1000	„			250	700

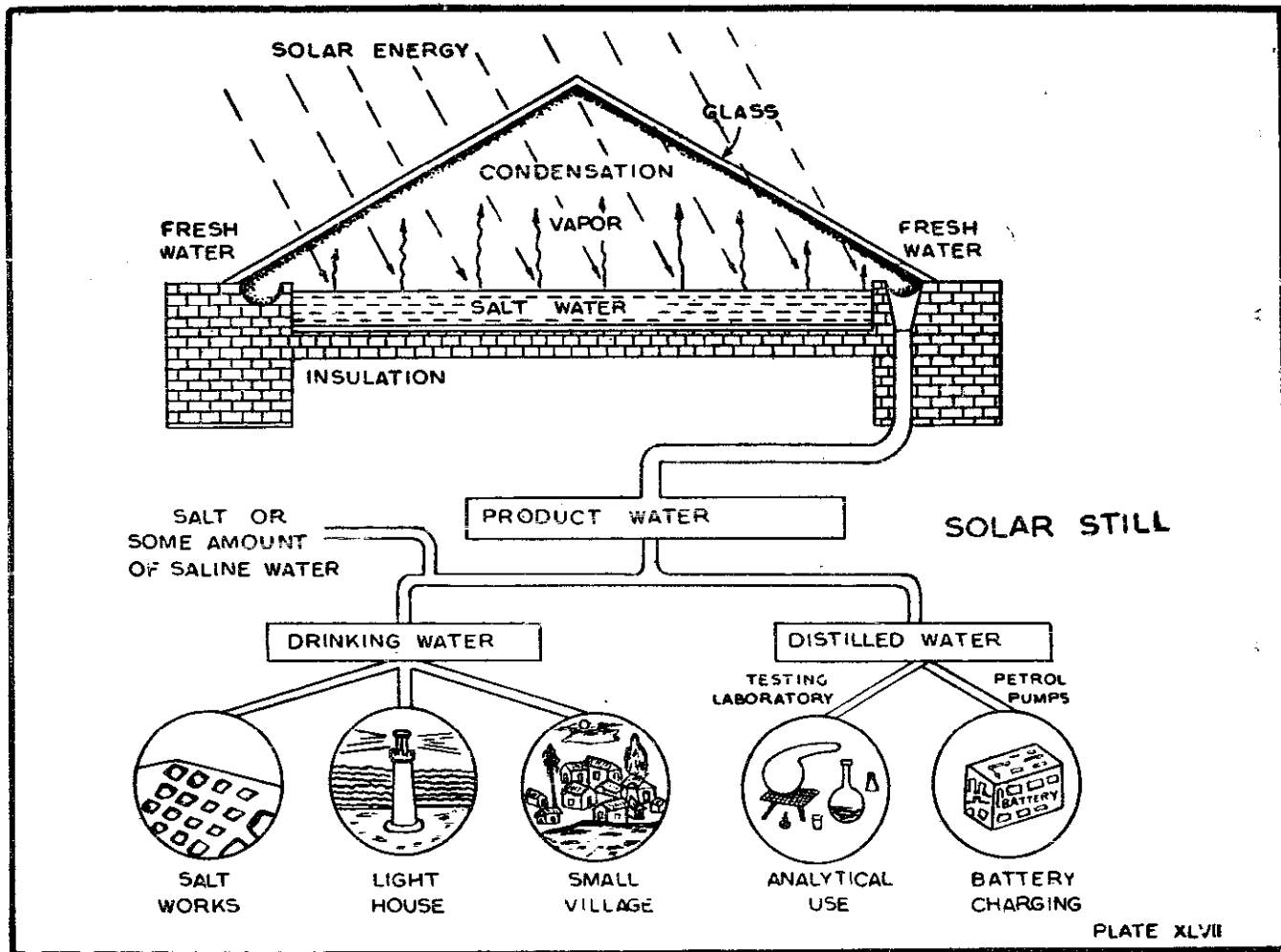

SOIL TESTING KIT

(Figures relate to Plate XLVIII)

Contact Agency : Agricultural Tool Research Centre, Bardoli, Gujarat

Introduction: To increase the production of food, farmers should be trained in the science of farming so that they may understand their problems and solve them in a scientific manner. They should be taught such principles in their own language as are applicable to their problems.

It is important for the farmers to learn about the composition and requirements of their land for growing various crops. And for this, a soil testing kit is a must.

Use of a soil testing kit: With the help of this kit, the farmer can carry out a test of the soil of his field to determine its potential productivity. He could also find out the types and quantities of various fertilizers needed for raising his crop.

How to use the kit: The following ingredients have to be determined in the field:—

- | | | | |
|---------------------|----|----|------------------------------------|
| 1. Alkalinity | .. | .. | pH value. |
| 2. Nitrogen | .. | .. | $\text{NH}_4\text{—N}$ (for paddy) |
| 3. Nitrate—Nitrogen | .. | .. | $\text{NO}_3\text{—N}$ |
| 4. Phosphate | .. | .. | P_2O_5 |
| 5. Lime | .. | .. | Ca(OH)_2 |
| 6. Potash | .. | .. | K_2O |
| 7. Magnesium | .. | .. | MgO |

The testing kit has provision to test all the above mentioned ingredients. It contains (i) chemicals in coloured plastic bottles with droppers, (ii) some powder in boxes, (iii) a bottle of distilled water, (iv) plastic spoons of 1-2 gm. for taking measured quantities of soil samples, (v) test tubes of various sizes, (vi) brush to clean test tubes. An instruction book is provided in the box to carry out various tests. This is a mini mobile laboratory.

The farmer can take the kit to the field and carry out the tests of the soil. He can thus add the required fertilizer or can decide upon the best crop according to soil type. Before using it, the farmer is given thorough training in the use of the kit.

Price: Rs. 300 per kit with one supply of chemicals.

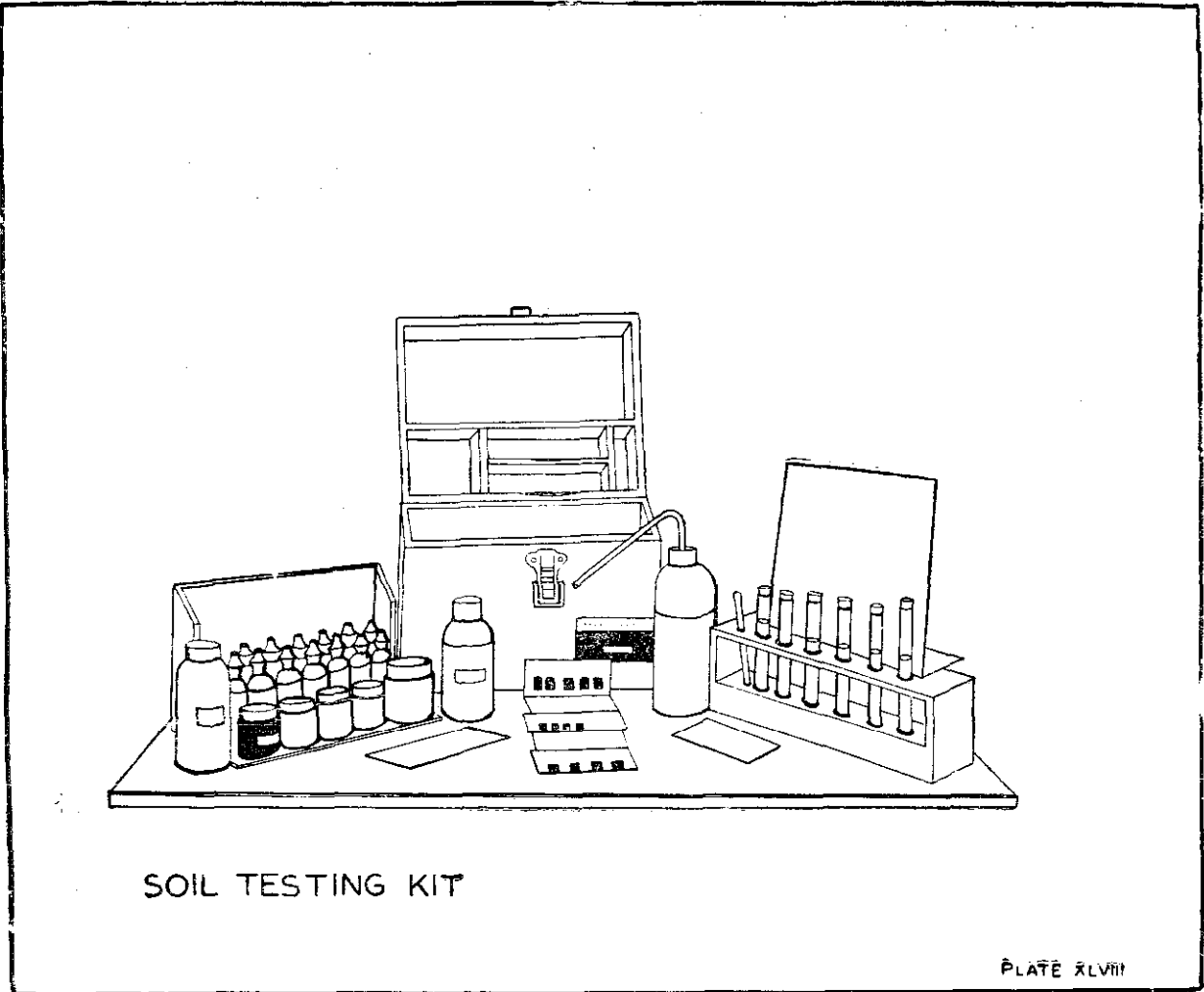

BETTER USE OF BLACKBOARDS

(Figures relate to XLIX)

Introduction : The blackboard occupies an important place in teaching students in class rooms. It makes a visible presentation of a lecture delivered by the teacher. Imaginative use of blackboards can capture the attention of the students and channel their interest to the subject. As the lesson progresses, the summary and points can be written on the blackboards. Sometimes students are also called to the blackboards to do small exercises.

Some tips on the use of blackboards

(1) The light falling on the blackboard must be of the correct illumination and from the correct angle giving maximum light but preventing glare.

(2) The lettering on the blackboard should be $2\frac{1}{2}$ " to 3" to make it visible to students sitting at the rear of the classroom.

(3) The blackboard should always be maintained in good condition and whenever its surface becomes worn or glossy, fresh black paint can be applied to give it an uniform dark background. The ingredients needed for the blackboard paint are :

(i) Non-greasy soot and ashes, left from a woodfire

(ii) Linseed oil

The ashes should be passed through a sieve to obtain a fine powder.

500 c.c. of linseed oil, 200 c.c. of fine powder of ashes and 5 tea spoonful of soot is mixed thoroughly to make a paint for the blackboard. At least a period of three weeks should be allowed for the surface to become absolutely dry and hard.

Practical tools for the blackboards

(1) A pair of compasses for drawing circles, made of a piece of rope with which chalk is tied at one end. (Fig. 1).

(2) A ruler for drawing straight lines. It must be straight and should stick well on the blackboard surface. (Fig. 2).

(3) A T-square which provides a convenient tool for drawing parallel lines and guide. (Fig. 3).

(4) Patterns should be prepared in advance to save time during class hours to draw maps, diagrams and figures. Sometimes it will be helpful to draw figures also in advance before the class starts and students assemble.

Making diagrams on the blackboard : The following methods could be used for making diagrams :

(1) *Grid Method :* With the grid technique, enlargement of original drawings made on ordinary size of paper could be obtained on the blackboard in larger scale. Some squares are drawn on the original drawings. The blackboard is blocked off in larger squares. The original drawings can thus be transferred to the blackboard by drawing one square at a time. (Fig. 4).

- (2) *Pattern Method*: This method is suitable for drawing complicated maps of villages, countries, states, etc. Drawings are made on a piece of paper for each illustration which has to be put on the blackboard. Then with a punch or perforating machine, the illustrations are perforated in outlines at 1" intervals. When the complete drawing has been punched out, the pattern is held against the blackboard and the duster is rubbed firmly across the perforated section on the outline. Thus an outline of chalk dots appears on the blackboard. These dots can be connected freehand with a chalk. (Fig. 5).
- (3) *Template Method*: Template can be made on any thin, stiff and light-weight material like cardboard or sheet metal. The design is drawn on the material and then cut off and the template is ready for use. The template is held against the blackboard with one hand and is outlined on the blackboard with a chalk.
- (4) *Elastograph Method*: The elastograph helps to make an enlarged copy of the diagram by using an elastic string. The original drawing is attached on the blackboard and one end of the elastic string is pinned at a point to the left of the diagram in such a way that, when stretching the string, the knot may cover a point of the drawing. At the other end of the string, a piece of chalk is attached which marks the enlarged drawing on the blackboard. The knot should be kept above the outline of the original drawing. The larger the distance between the chalk and the knot, the greater is the enlargement obtained. (Fig. 6).

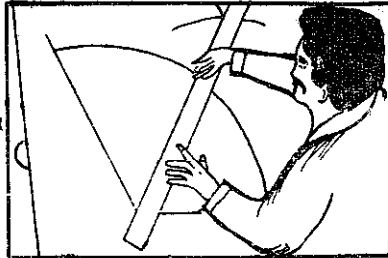
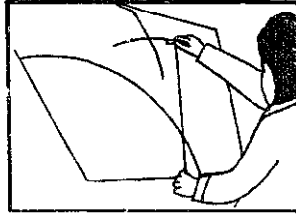

A PAIR OF COMPASSES FOR DRAWING CIRCLES MADE OF ROPE
FIG.1

A RULER FOR DRAWING STRAIGHT LINES
FIG.2

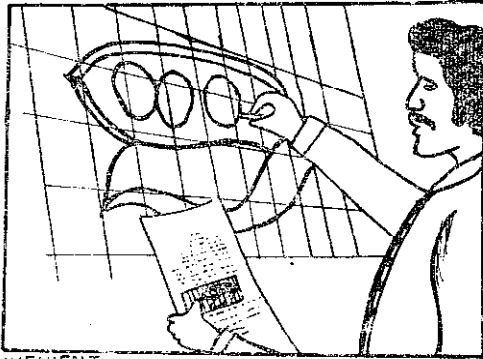
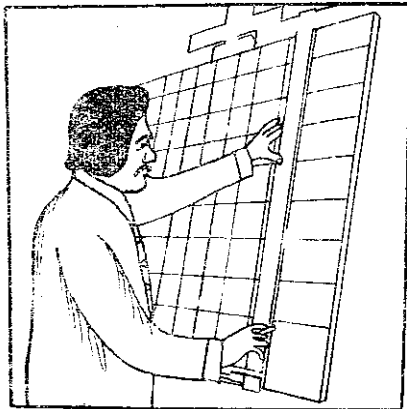

A T-SQUARE WHICH PROVIDES A CONVENIENT TOOL FOR DRAWING PARALLEL GUIDE LINES.
FIG.3

THE GRID METHOD
FIG.4



FIG.5
THE PATTERN METHOD

FIG.6

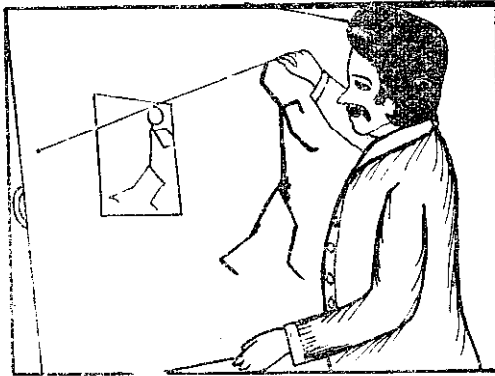

THE ELASTOGRAPH TECHNIQUE

BLACK BOARD TIPS

FILMSTRIPS FOR EDUCATION

(*Figures relate to Plates L, LA*)

Contact Agency : Robert Tayyabji, UNICEF, 9 Jorbagh, New Delhi.

Introduction: The filmstrip is a simple and relatively inexpensive way of transmitting visual information. It has a great potential as an aid for developmental and motivational communication, because it combines the advantages of modern projected media with vital personal contact between the communicator and his audience.

If produced locally so as to feature familiar faces, sights, problems and areas of interest, it is inexpensive and has a tremendous advantage over external, centrally produced materials.

How to produce filmstrips: The technique reduces filmstrip making to a series of simple do-it-yourself operations. It is appropriate to the needs of the extension workers operating in backward, rural and remote areas. They can photograph, develop, edit, print and project their own black and white filmstrips, without having to depend on outside professional services or having access to complex photographic technique and equipment.

Viable photographic system would have to satisfy conflicting requirements and design parameters as follows:

- (a) The design has to take into account inhibitions, social restrictions, etc.
- (b) Mechanical simplicity is essential.
- (c) The system should be capable of turning out filmstrips of acceptable standard, if care and practice is shown by the user.
- (d) It has to be self-contained and should include a projector to be operated with electricity.
- (e) Film should be inexpensive and readily available at the nearest town stores.
- (f) The cost of production should be reasonable and within the budget of the local extension worker.

Prototype production kit: The prototype filmstrip production kit contains (a) an automatic 35 mm. camera and flash, (Fig. 1); (b) a copy stand for close-up photography, copying and tilting, (Fig. 2); (c) a day-light developing tank and special single-bath-chemicals for film processing, (Fig. 3); (d) a mains and battery operated projector. (Fig. 4).

A package of film, chemicals and other expandable items are included in each kit initially. The projector is a separate unit with its own carrying case, which facilitates transportation from village to village.

Making a filmstrip involves the following steps:

- (a) Prepare rough story board and short list for the proposed film strips.
- (b) Photograph the desired subjects.

- (c) Process the exposed film.
- (d) Cut developed negative films into individual frames and mount them in standard 35 mm. slide movements.
- (e) Edit negative slides by projecting them, choosing the best and arranging them in desired order. Store selected negatives in transparent plastic slide folders.
- (f) Using the projector, print the filmstrips by projecting the negatives in the desired sequences on a paper screen which is attached to the copy stand. Photograph the projected images one after the other, and superimpose sub-titles and other graphic notations on any desired frame by writing them on the paper screen.
- (g) Take the projector with carrying case and built-in A.C. power-pack and DC cable to the village or class room and project the filmstrip before the audience.

Close-up photography with the copy stand, flash and reflector

It is possible to take sharp, evenly lit pictures of small objects, and to photograph maps, charts, diagrams, title cards and pages from books and magazines by using the camera in conjunction with the copy stand, flash unit and reflectors. (Fig. 6). A lens has been permanently attached to the copy stand. The copy stand can be used vertically or horizontally and is hinged to fold flat. (Fig. 7).

A special reflector is used to bounce and diffuse light from the electronic flash so that the subject is illuminated evenly. The flash is attached to a hot shoe on the reflector bracket. (Fig. 8). Important dimensions of the copy-stand are given in Fig. 9.

Film processing : The kit contains a day-light developing tank, a plastic shaker bottle, scissors, clips and strings for hanging wet film and packets of 'one-shot,' mono. bath-developing powder. (Fig. 3).

The film processing is done as follows:

- (i) Load film in developing tank.
- (ii) Pour developing powder from a packet into shaker bottle and add water to the mark. Well water can be generally relied upon to yield acceptable result.
- (iii) Shake bottle to dissolve powder, then pour solution into tank and agitate. In 10 mts., the film is developed, fixed and cleared.
- (iv) Discard used solution and wash film in fresh water. Remove film from the tank and hang up to dry.

Printing the film-strip positive : For this operation, the camera, copy stand and projector are combined into an optical printer. The projector is placed behind the copy stand. It projects an image through a window located below the camera bracket. The projected image is focussed on a sheet of white paper attached to a copy stand frame, when photographed and developed, a positive image results. A succession of positive images is recorded on the cover film by progressively photographing the image of each negative slide.

Projection for printing : Fig. 10 illustrates the relationship between the projector, copy stand and camera when printing a film strip. Projector

to screen distance is 350 mm. for an image of 225 mm. width. Therefore, a projection lens of 50 mm. focal length is required. Most of the distortion can be attenuated to an acceptable level by off-setting the projection lens with respect to the optical of object slide and condenser lens. (Fig. 11).

Filmstrip Projection : For the projection of filmstrip before an audience a projection lens of about 100 mm. focal length is required. Two separate projection lenses are, therefore, needed. An inexpensive but workable alternative is to use a 75 mm. projection lens with close-up lens permanently installed behind it and a reversible conversion lens in the front of effective focal length of 55 mm. (with the conversion lens screened in one way); and a focal length of 80 mm. with the conversion lens reversed for projection is obtained. (Fig. 11).

<i>Price</i>					
<i>Items</i>			<i>Quantity</i>		<i>Approx. Price Rs.</i>
1. 35 mm. camera	1	500
2. Electronic flash	1	100
3. Close-up lens for copy stand and projector			..	2	50
4. Projection lens	1	60
5. Conversion lens	1	60
6. Filmstrip carrier	1	50
7. Projection lamp	1	20
8. Condenser lens	2	100
9. Lampholder assembly	1	200
10. Hot shoe for reflector	1	10
11. Developing tank	1	50
12. Wooden copy stand			..	1 Set	50
13. Scissors, measuring jar, clips carrying bag			..	1 set	20
17. Projector chassis	1 set	50
15. Battery cable for DC operation			..	1	20
16. Carrying case for projector	1	30
17. Wooden kit box	1	10
18. Miscellaneous		20
			Total	..	1400

Material required for 10 original filmstrips:

1. 35 mm. film	30 rolls	300
2. Slide mounts	600 each	100
3. Chemicals	30 pkts	50
4. Slide folders	20	60
5. Paper, felt-tipped pens, batteries for flash units			..		100
			Total	..	610

PLATE L

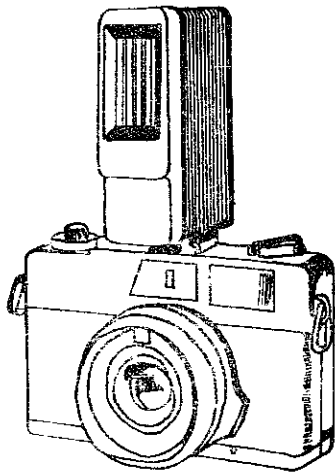
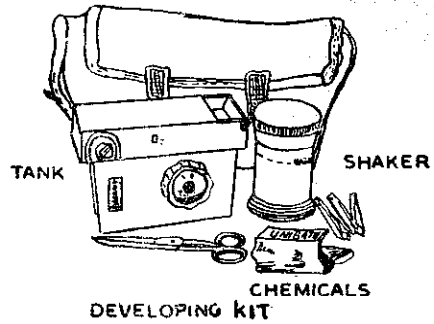

FIG 1

CAMERA AND FLASH



DEVELOPING KIT

FIG 2

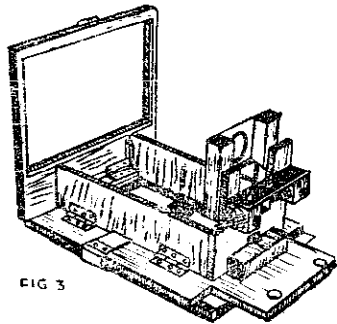

FIG 3

COPY STAND

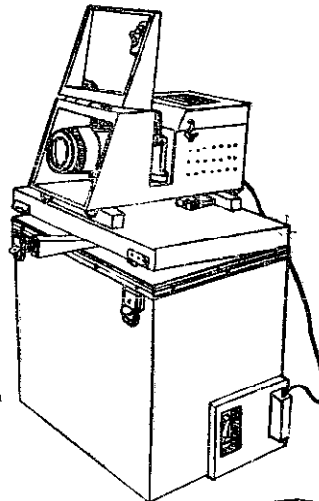

FIG 4

PROJECTOR AND CASE
PROJECTING
A FILMSTRIP

CLIPBOARD

COPY STAND

FIG 5

PROJECTOR
PRINTING A FILMSTRIP, CAMERA,
COPY STAND, CLIPBOARD WITH PAPER
SCREEN AND PROJECTOR COMBINED
INTO AN OPTICAL PRINTER

**PRODUCING YOUR OWN
FILMSTRIPS**

PLATE LA

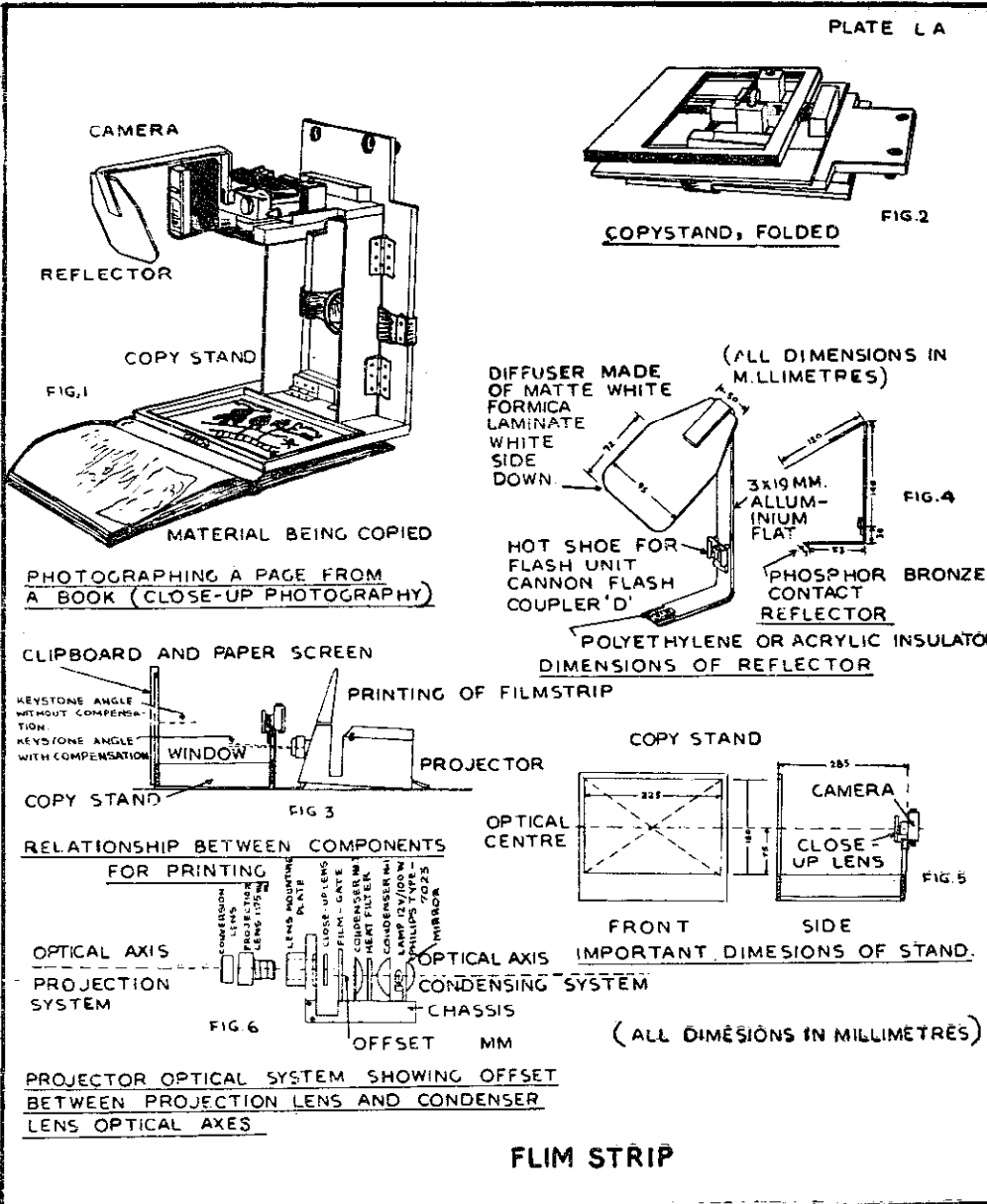

PUPPET MAKING AND PUPPET PLAYS

(Figures relate to Plates LI, LIA, LIB)

Contact Agency: Literacy House, Lucknow

Introduction: Puppetry is one of the ancient arts of India. The villagers love to see puppet shows, and laugh with its comedies and cry in the tragedies and see the problems of their lives in its enactment. It has unlimited possibilities in the village for: (1) entertainment, (2) education, (3) self-expression and (4) social action.

It is an inexpensive method of true audio-visual aid to teaching, if skillfully practised. Health, agriculture, literacy, sanitation and other problems can be dramatised on the puppet stage with good effect. It also gives chance to the puppeteers and artists to express themselves clearly and fully.

Construction: The glove or hand puppet is the simplest type to make. It is worn on the hand. The puppet head is hollow and fits on the first finger of the puppeteers' hand. (Fig. 13 and 14). The puppet hands are also hollow and fit on the thumb and the middle finger of the puppeteers' hand.

The marionette or string puppet has a jointed body and limbs. It can be made of wood, wire, paper string, cloth stuffed with paper, rag or sawdust. It is suspended by strings which are attached to different places on the body and limbs and to a control in the puppeteers' hand. Movement of the puppet is produced by moving the control and by pulling or loosening the strings. This requires considerable practice. (Fig. 2).

Materials used

1. Card board—a used postcard will do
2. Glue or paste
3. Old newspaper
4. Blank paper—12" square
5. String—two pieces each about 8" long
6. Black ink or paint
7. Red ink or paint
8. White chalk or paint
9. Pen, brushes or small pointed sticks
10. Gay coloured cloth
11. Needle and thread
12. A pair of scissors

Process

1. Roll the cardboard around your index finger, (Fig. 2); make a tube which fits the finger. Paste or glue the tube firmly. This will be the neck of the puppet.
2. Crumple a newspaper to make the stuffing of the head. Press the crumpled newspaper over and around the tube on your finger, (Fig. 3), giving it a rough shape.

3. Cover the crumpled newspaper stuffing with the sheet of a blank paper in such a way that the side on which the face will be painted is as free of crease as possible. Put all the creases and folds on the back side. Tie the paper tightly in place at the neck. (Fig. 4.).
4. Paint the face on the smooth side of the head. A few bold features, e.g., large black eyes, long sweeping eyebrows, and a wide red mouth are most effective. (Fig. 5).
5. Take a piece of bright coloured cloth and sew it to form a tube of cloth long enough to cover your hand and forearm. (Fig. 6).
6. Put the head inside the cloth tube upside down, so that the back of the head is towards the seam. (Fig. 7).
7. With the second piece of string, tie the cloth on to the neck tube. Tie firmly with three knots. Do not block the opening in the neck tube. (Fig. 8).
8. Turn the cloth right side out, so that the head is exposed. (Fig. 9).
9. Put the puppet on your hand in such a way that your first finger goes into the neck and lets the dress fall on your forearm. Cut slits for the tip of your thumb and middle finger to peep through. These are puppet's hands. (Fig. 10).
10. Add any distinguishing mark such as moustache or beard. Make a turban or a cap for a man, or a sari for a woman. (Fig. 11).
11. Give the puppet a name and practise moving the puppet in front of a mirror until it looks as if it were alive. (Fig. 12 and 13).

Puppet stage : One-cot stage is the most suitable for village use. The frame of the cot is turned on its side. (Fig. 14). Drape sheets, curtains, blankets or rugs over this frame and fasten securely so as to form a screen. (Fig. 15). The puppeteer sits behind the screen and holds up the puppets on his hand so that the spectators see the puppets above the screen. (Fig. 16).

A puppet show can be seen in Figure 17.

Enacting a puppet show : The puppet play is a drama and should conform to its rules. It must be full of action; interest being aroused at the beginning of the play and sustained throughout. Suspense, wit and humour should be introduced in the play. Short speeches, and quiz and dialogues are easy to present.

The puppeteer should be good at mimicry and should be able to speak in a different voice for each puppet. Move the puppet only when it is speaking, otherwise keep it still. One puppet can be put in on each hand and thus only two characters can appear in one scene.

The plot should run smoothly until the curtain drops at the end of a scene. Time must be given to change the puppet in one's hands and yet there must not be long pauses. Changing of characters can take place between scenes or during music.

It is a work of art, and only an artist can enact a good and interesting show.

PLATE L I

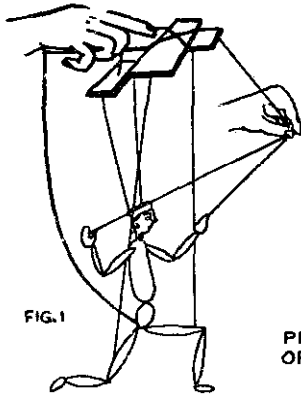

FIG. 1

THE MARIONETTE OR STRING PUPPET

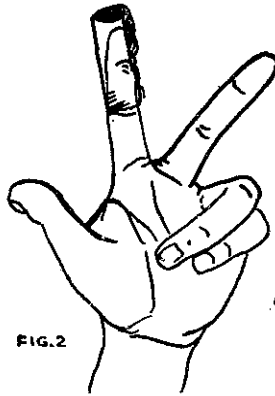

FIG. 2

PREPARATION OF THE NECK OF PUPPET BY CARDBOARD



FIG. 3

CRUMPLE THE NEWSPAPER TO MAKE THE STUFFING OF THE HEAD.

PAINT THE FACE ON THE SMOOTH SIDE OF THE HEAD

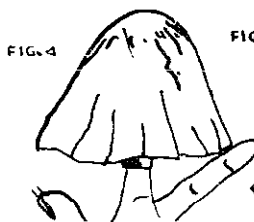

FIG. 4

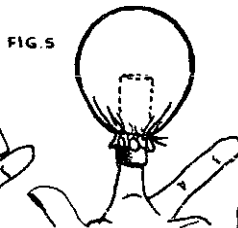

FIG. 5



FIG. 6

COVER THE CRUMPLED NEWSPAPER STUFFING WITH THE SHEET OF PLAIN PAPER IN SUCH A WAY THAT THE SIDE ON WHICH THE FACE WILL BE PAINTED IS AS FREE OF CREASES AS POSSIBLE.

A TAKE A PIECE OF BRIGHT COLOURED CLOTH AND SEW IT TO FORM A TUBE OF CLOTH, LONG ENOUGH TO COVER YOUR HAND AND FOREARM.

B PUT THE HEAD INSIDE THE CLOTH TUBE UPSIDE DOWN SO THAT THE BACK OF THE HEAD IS TOWARDS THE SEAM.

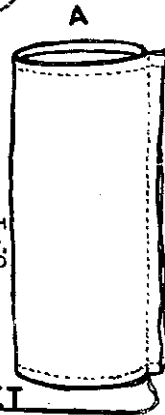

FIG. 7



FIG. 8

TO MAKE SIMPLE HAND PUPPET

PLATE LIA



TIE THE CLOTH ON TO THE NECK TUBE
FIG. 1



TURN THE CLOTH RIGHT SIDE OUT SO THAT THE HEAD COMES OUT
FIG. 2



PUT THE PUPPET ON YOUR HAND LIKE HIM.
FIG. 3



FIG. 4

ADD ANY DISTINGUISHING MARKS SUCH AS A MOUSTACHE OR BEARD.

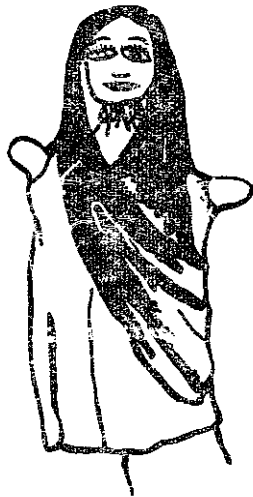

FIG. 5

PRACTISE MOVING THE PUPPET IN FRONT OF A MIRROR UNTIL THE PUPPET LOOKS AS IF IT WERE ALIVE.

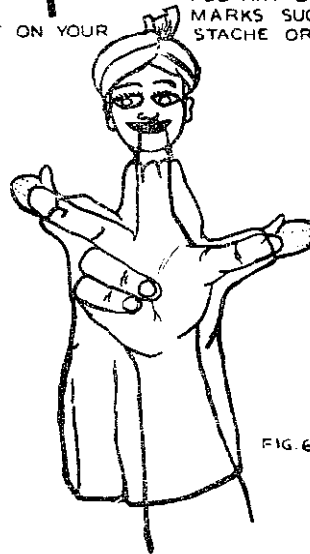

FIG. 6

THE PUPPET IS NOW READY FOR USE.

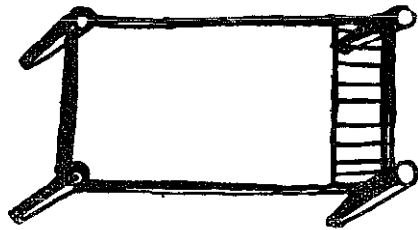

FIG. 1

1. THE FRAME OF THE SCREEN IS A CHARPOY TURNED ON ITS SIDE.
DRAPE SHEETS CURTAINS BLANKETS OR RUGS OVER

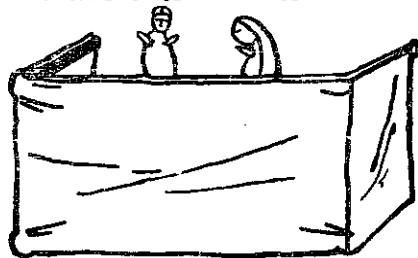

FIG. 3

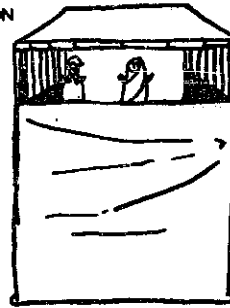

FIG. 4

THE PUPPETEERS SIT BEHIND THE SCREEN AND HOLD UP THE PUPPETS ON THEIR HANDS SO AS TO FORM A SCREEN.

A SCENE OF PUPPET'S GAME.

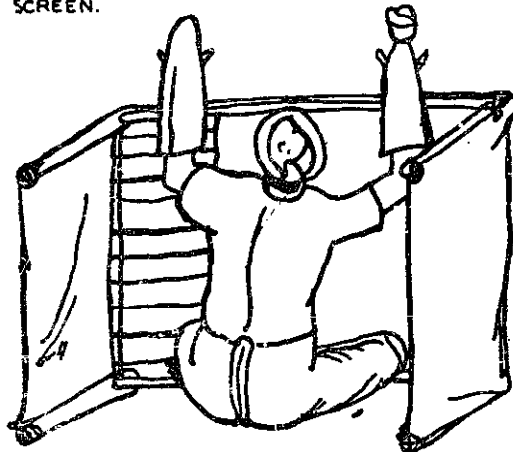

FIG. 5

THE PUPPETEERS THEMSELVES MUST NOT BE SEEN BY THE AUDIENCE.

Water, Power, and Energy

INTRODUCTION

The most important things for human beings to subsist on are air and water. Mercifully, the provision of air has been made free of cost by nature. This, however, is not absolutely true of water in our country. In spite of its abundance in nature, there is not sufficient water available to drink in all places, especially in the rural areas. There are still some pockets in India where water is not available for drinking and washing throughout the year. Women and children have to trek for miles to fetch water in their pitchers for their domestic use. It may not be possible to provide safe drinking water to all the rural areas through piped supply schemes as has been done for the towns and cities but there is a need to develop a simple technology which could ensure safe drinking water supply to the local people throughout the year from wells, small tubewells or by just collecting rain water and purifying stagnant and brackish water.

For drawing water from inner strata for pumping and other purposes, power and energy are required. Power and energy are very important because they are the means through which people are able to do things more easily and with greater efficiency, and multiply manifold their muscle power endowed by nature. Even for cooking food, energy is needed. At present, most of the fuel needs of the rural areas of India are met either by cowdung or wood; power needs are met by animal and manual labour. The use of the first two materials is disastrous for the fertility of the soil as well as preservation of the trees and eco-system. Animal power or human power is not sufficient to run the industry and produce for the livelihood of the people. It is almost impossible to think of taking electricity to every village, especially, in view of the oil and fuel crises in general. Even if the electric lines are laid down in all the villages, it may not be possible to supply wattage and power sufficient for all the needs of the villages.

Appropriate technology has to play a very important role in the field of power and energy. By means of simple contrivance and harnessing the free gift of nature like sun, wind and water, energy could be produced which would be very useful at the local level. Anaerobic digestion of the cattle dungs and other refuses can produce methane gas which could be used for cooking, lighting and running of engines. A lot has been said lately about *gobar*-gas plants and, of course, at many places they have worked wonders, by providing free energy, producing high quality organic manures and solving the sanitation problem of the rural areas. However, a lot of research is further needed to overcome the problem of low temperature when very little gas is generated, especially in the northern region, where winter is severe. There are other problems of reducing the time of digestion cycle and storing the gas in some suitable receptacle. Research is needed by the best brains of this country before taking up the introduction of these appliances on a massive scale in the rural areas. The same is true about solar energy, wind mills and hydraulic energy. Ample research is needed to perfect these appliances and make them suitable for the village conditions. There is a need of revival of water wheels and its improvement and modifications.

Some of these appliances which were developed recently or long ago and have been found suitable for the rural areas, are described in this section.

FORMS FOR CASTING WELL RINGS

(Figures relate to Plate LII, LIIA)

Contact Agency: Friends Rural Centre, Rasulia, M. P.

Introduction: Ring wells are the result of an ingenious device of digging wells of a moderate size. The digging and lining work is carried out simultaneously. There is no need of brick lining and plastering with cement, because the rings are themselves pre-fabricated with concrete. This has proved a great success in Madhya Pradesh, U. P. and Bihar. The rings and other auxiliary parts are manufactured locally by blacksmiths and semi-skilled mechanics.

Method of construction: Two angle irons are drilled to take $3/8$ " bolts so that they may be bolted together. Rivet holes are drilled in the other faces. $2' \times 9\frac{1}{4}'$ iron sheet is laid on the ground and angle irons positioned on both ends. The sheet is bent into a cylindrical shape by hammering. The sizes are adjusted to make 3" or 4" thick rings. The inside form is hammered with the angle iron facing upwards, and the outside form has its angle iron facing downwards. It is then bolted together and any defect in shape corrected by hammering either inside or outside. The wooden piece is now prepared and drilled the same way as the flange angle iron on the inside form and inserted in the joint between the two flanges with the side having a $1\frac{1}{2}"$ face placed outward and held by two $2\frac{1}{2}" \times \frac{3}{8}"$ bolts.

Materials required

	<i>Number</i>	<i>Size</i>
1. 14 swg. black iron sheet	1	$2' \times 9'4"$
2. 14 " " " " " "	1	$2' \times 11'$
<i>or, if that size is not available, then</i>	2	$2' \times 6'$
3. Wood piece	1	$2' \times 2" \times 1\frac{1}{4}"$
4. Bolts and nuts	2	$3/8" \times 2\frac{1}{2}"$
5. " " " " " "	10	$1\frac{1}{4}" \times 3/4"$
6. Iron rivets	24	$3/16" \times 3/4"$
7. Roofing bolts and nuts	10	$1/4" \times 3/4"$
8. Angle iron $1\frac{1}{2}" \times 1\frac{1}{4}" \times 1/8"$	2	2' long
9. " " $1\frac{1}{2}" \times 1\frac{1}{4}" \times 1/8"$	12	1/6" long

PLATE LII

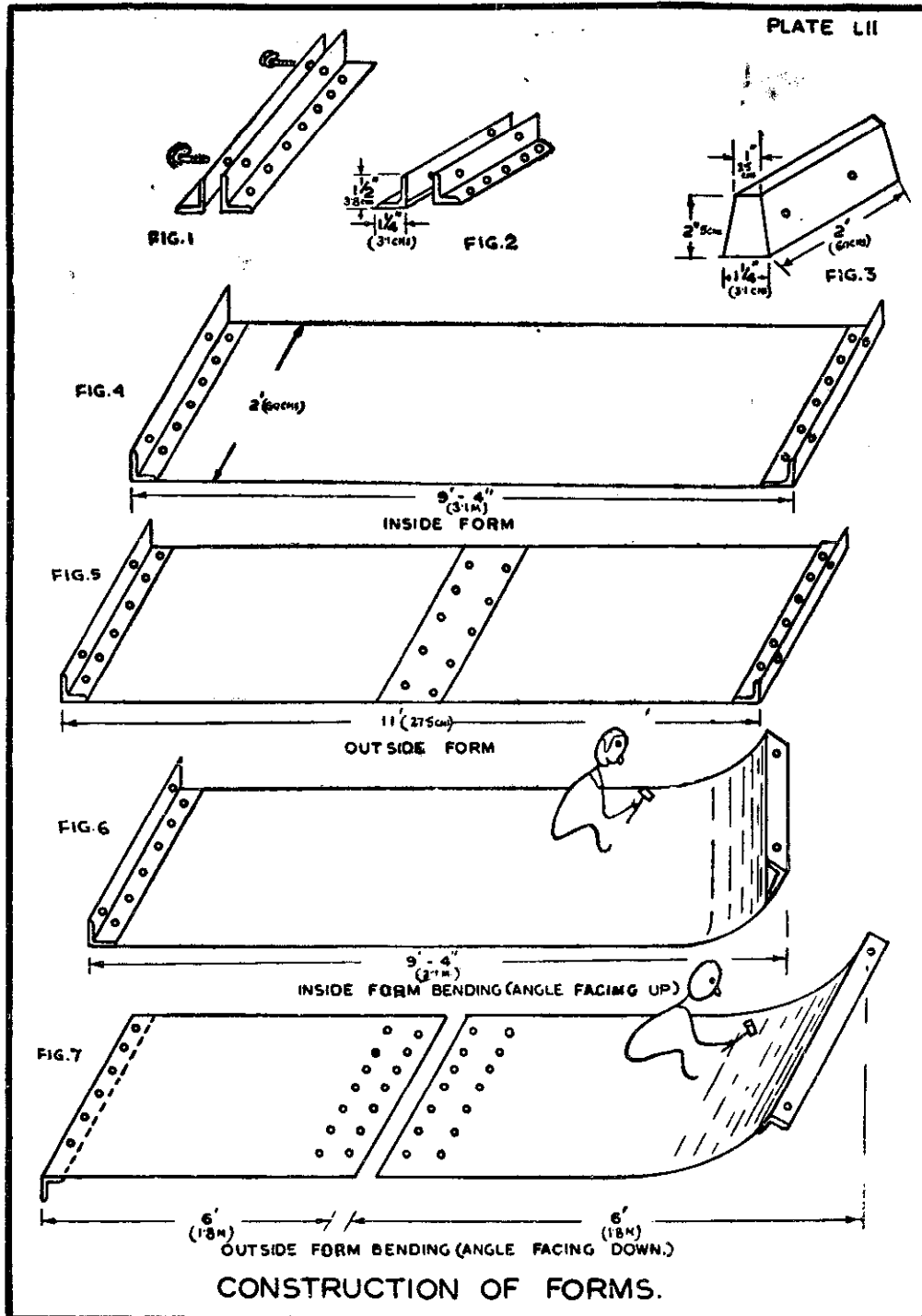

PRECAST REINFORCED CONCRETE WELL-LINING RINGS

(Figures relate to Plate LIIA)

Contact Agency : Friends Rural Centre, Rasulia, M.P.

Method of Casting : The forms are set up on a level piece of ground preferably on a concrete platform. It should be wiped once with oil before each casting. The surface of the forms to come into contact with the cement should also be wiped with oil. The inside form is then assembled in its place and outer form positioned symmetrical around it, as shown in Fig. 1 and Fig. 2. Three blocks of wood can be used for this.

Reinforcing rods are then put in place; two rings of $\frac{1}{4}$ " round steel rod placed 3" from the top and 3" from the bottom of the form. These are held in place by three upright rods as shown, to hold the lower and upper rings and also to form the lifting loops. These are bent and assembled as shown in Fig. 3 and 4.

The concrete mixture is then prepared as follows :

One part by volume of cement, two parts by volume of sand, and three parts by volume of stone chips or river gravel, are taken and thoroughly mixed dry and then enough water added to give it a stiff consistency. Cement, sand and gravel should always be measured with the same container, filled level-full up and not just with shovel. The amount of water should also be measured and should only be varied if the sand and stone is wetter or drier than usual. If the proportion of sand, gravel, cement and water is wrong, the rings will not attain their full strength and might break either in transporting or in use.

The mixture is then placed between the inner and the outer forms and tapped with the steel bar to work it around the reinforcement and to fill all voids. When the inner form has been filled to the level of the outside form, the top is smoothed with a trowel and left for 24 hrs. to set. Make certain that the lifting loops are near the outer edge of the ring.

After 24 hrs. the forms can be removed; the two bolts holding together the inner form and the piece of wood are removed. The wood spacer is now removed by tapping inwards. This releases the inner form. A few light taps will loosen it from the concrete ring and it can be lifted out. The outside form is now removed by loosening the two bolts holding it together and lifting it off. Care is necessary in order not to damage the concrete ring which is still fragile. The rings should be left where it has been cast, without removing for 7 days, during which duration it must be kept wet all the time as concrete can only be cured if it remains wet. They may be covered with damp sack or damp straw. After a week they may be lifted on to their site and rolled and stored until needed.

To make special first ring, the outer form is assembled with the insert piece, the reinforcing is placed into the form upside down with the lifting loops bent inwards under the inner form. It is also better to use three rings of iron. When the form is filled, the top is smoothed sloping inwards, so that the outer edge of the ring makes a cutting edge to facilitate sinking in the ground. (Fig. 5 and 6).



METAL SKIRT WITH ANCHOR LOOPS

FIG. 1.

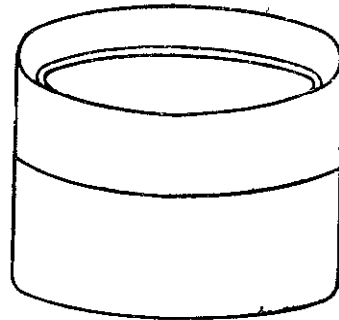

SPECIAL FIRST RING WITH METAL EDGE.

FIG. 2.

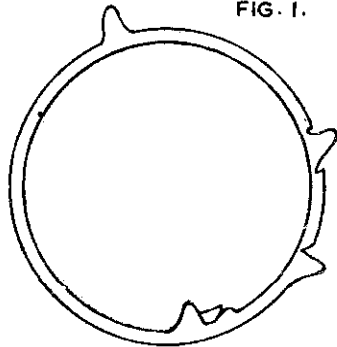

FIG. 3 FORMS PLACED READY FOR CASTING WITH REINFORCING IN PLACE.

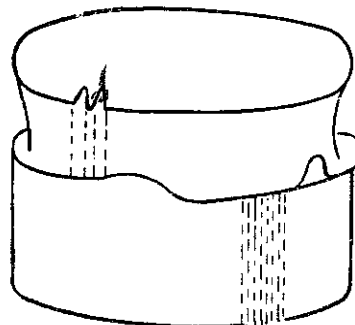

FIG. 4.

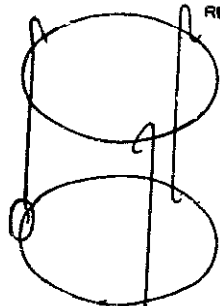

FIG. 5.

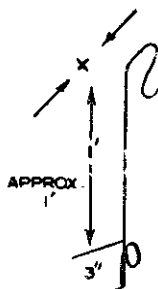

FIG. 6.

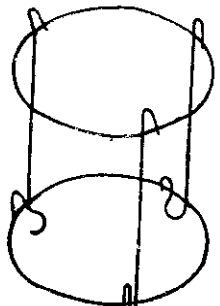

FIG. 7.

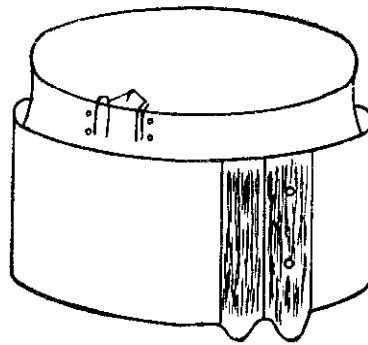

FIG. 8.

CASTING OF RINGS.

RING WELL INSTALLATION

(*Figures relate to Plate LIII*)

Contact Agency : Friends Rural Centre, Rasulia, M.P.

Method of construction : Precast reinforced concrete well rings 4 ft. diameter are used. On the selected ground for the well, a circle 1" larger in diameter than the 'special first ring' is drawn. The marked out circle is excavated. Walls are kept perfectly vertical and the diameter checked frequently. The digging is continued as long as the well is stable, or until water is reached. When the depth of the hole is more than a few feet, a simple winch is placed over the hole and used to lift out the buckets or baskets of excavated soil to help people to enter or leave the well.

If the well is unstable, crumbling or cracking, or if water is reached, rings have to be inserted into the well. The purpose of the rings is to support the walls of the well to prevent stones and earth from falling on the man working inside the well. These rings form the wall of the finished well.

To insert the rings, first the base of the well is levelled and then the special first ring is lowered to the bottom. This ring has the same inside diameter as other rings but its outside diameter is 2" larger than of others and it has a lower bevelled cutting edge to facilitate sinking in the ground. The larger outside dia. of the ring ensures that as the first ring sinks during digging, the other smaller rings will easily follow.

As the other rings are lowered into the well one at a time, a man has got to go down into the well and align each ring with the one below it. When the well is lined to the top, clamps are attached from the lifting loops on the first ring to the rim of the uppermost ring and then tightened so that all the rings move together as one pipe.

When the rings are in place and clamped, a man goes into the well and keeps digging out the earth in such a manner that the rings sink. It is important that the man at the top ensures that the rings are sinking straight. When the rings have sunk a few feet, the clamps are removed, more rings are added at the top and then the clamps are extended and replaced. The extending can be done with $\frac{1}{4}$ " round reinforcing bar. The work of digging below and adding rings at the top continues until the well is completed. When the water level is reached, the work continues in the same manner—the man at the top lifting out water in addition to the soil until the water flow is faster than can be lifted out.

Barpoli type well : The well is dug in the same way as the Rasulia type well, but only about 4 rings are used. If the soil above the ring is unstable or crumbling, then temporary wooden shuttering has to be employed. When the required depth is reached and sufficient water is coming into the well, the rings are covered with a heavy reinforced concrete lid fitted with a hole and cement pipe; this pipe is extended to the top. The shuttering, if it was used, is now removed, and the hole is filled in, leaving only the concrete pipe. Around this is cast a cement platform and a hand pump is fitted over the hole. In this manner one can obtain a good well giving clean uncontaminated water at a much lower cost.

Some important data

1. Dia. of the finished well	4 ft.
2. Depth of the finished well	60 ft.
3. Gallons of water/hr.(max.)	10,000
4. No. of men working	5
5. Total time to complete	3 weeks
6. Total volume of earth excavated	10,000 cu. ft.
7. Average excavated vol./man/day	5 cu. ft.
8. Approximate cost of labour, material and pump	Rs.4,000/-		

The ring-well method can also be used for deepening ordinary wells.

The Planning Research and Action Institute, Lucknow did useful work in sinking 4 ft. diameter ring-wells in the districts of Pilibhit and Shahjahanpur during the sixties. The technique was almost the same as mentioned earlier.

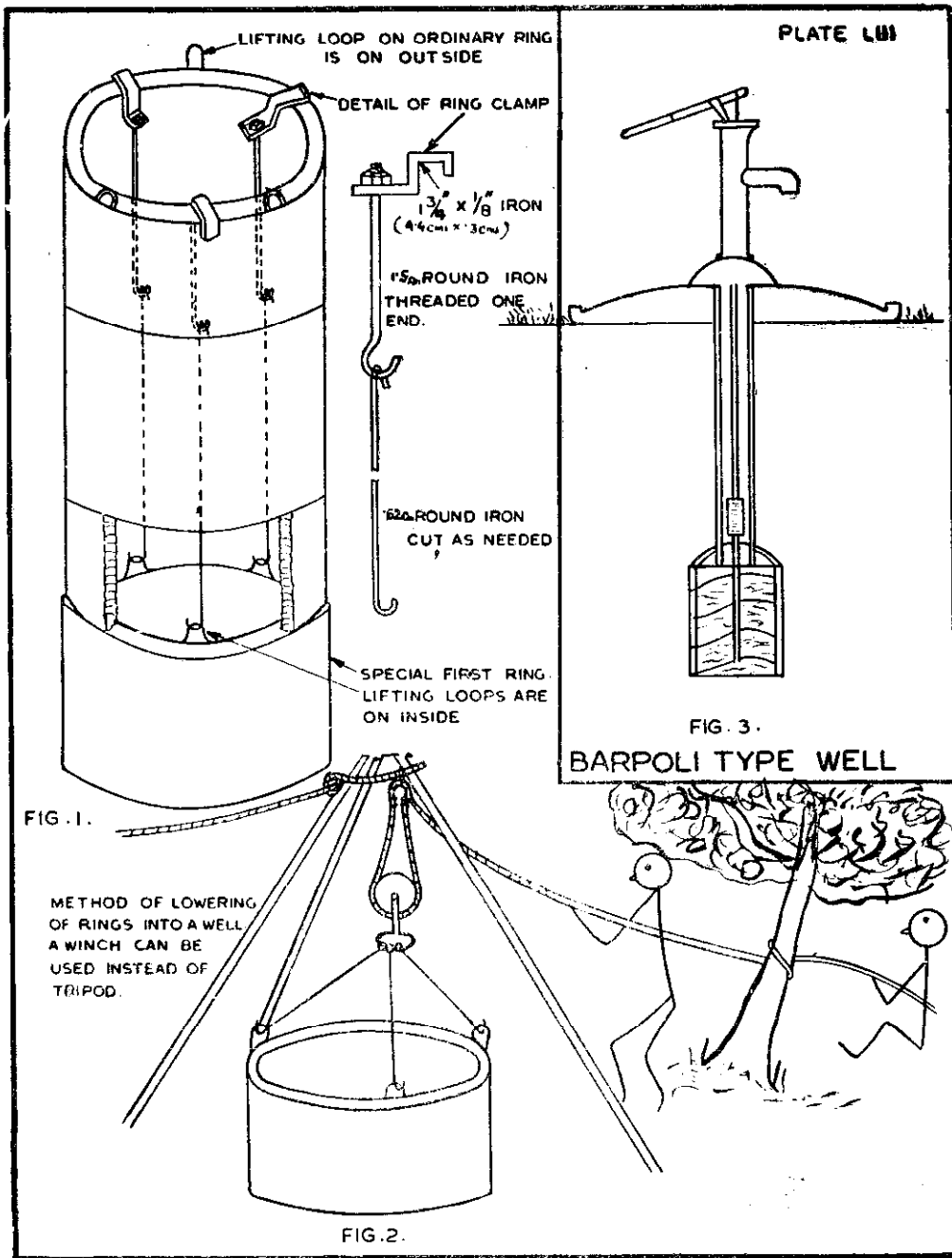

HAND PUMPS FOR VILLAGE USE

(Figures relate to Plates LIV, LIVA)

Contact Agency : Friends Rural Centre, Rasulia, District Hoshangabad, M.P.

Introduction : The hand pumps are commonly used in India for the supply of safe drinking water in the rural areas. The equipment is available in plenty with ordinary iron dealers. Hand pumps can be fabricated at the village level and fixed for lifting water. Friends Rural Centre has worked out a simple system for the fabrication of hand pumps at the village level. It is described below :

Method of Construction

1. *Handle* : This is cut out of a piece of tough hard wood (seasoned salwood) 14" long and $2\frac{1}{2}" \times 2\frac{1}{2}"$. (Fig. 1). It may be conveniently shaped on the simple hand turned lathe used by most village carpenters. A slot $\frac{3}{4}"$ wide is cut out at the end to accommodate the rod. All other holes are made as given in the figure.

2. *Rod* : This is made of mild steel, (Fig. 2), $\frac{3}{4}"$ dia. and 16" long with a $\frac{3}{8}"$ dia. hole centered 1" from one end. Holes of $\frac{3}{8}"$ dia. are drilled through the rod from each end $1\frac{1}{4}"$ in depth. These two holes are tapped with $\frac{3}{8}"$ thread. A 1" long machine bolt is screwed into one of the holes that runs into the cross-wise hole. The other receives the upper end of the plunger rod.

3. *Link* : This consists of two pieces of flat-steel strap iron $10\frac{1}{2}"$ long and $1\frac{1}{2}"$ thick and $2\frac{1}{2}"$ wide. (Fig. 3). Two half inch holes are drilled in the middle of each of these centered 1" from the ends. Both pieces are drilled at the same time to ensure that the spacing of the holes is the same.

4. *Block* : This is made from a piece of dense hard wood such as sal. (Fig. 4). It forms the base of the lever mechanism and at the same time serves as a guide-bushing for the rod and means of fastening the mechanism to the barrel of the pump. If this block is made with accuracy the lever will function well and last long. The wood should be seasoned and free from cracks and a square block $9" \times 2\frac{1}{2}" \times 2\frac{1}{2}"$ is prepared. Four holes, A, B, C and D, are drilled as given in the figure. Hole B is centered four inches from one end of the block end, and 5" from the other and is bored $\frac{3}{4}"$ in dia. to accommodate and act as a bushing for the rod. Holes A and C are $\frac{1}{2}"$ dia. and positioned to allow bolting the block bushing to the head of the pump barrel. Hole D is drilled from side to side $\frac{1}{2}"$ dia. and centered $\frac{3}{4}"$ from the bottom and $\frac{3}{4}"$ from the end between hole C and the end.

Next, the block is sawn into two pieces in a plane 1" below the top side. After cutting into two hole B at the upper side of the lower piece is enlarged with a chisel to form an oil well around the rod. A $\frac{1}{4}"$ hole is then drilled at an angle through the upper section align to with this. A second oil hole is drilled at E to meet with the hole D. (Fig. 4 and Fig. 5).

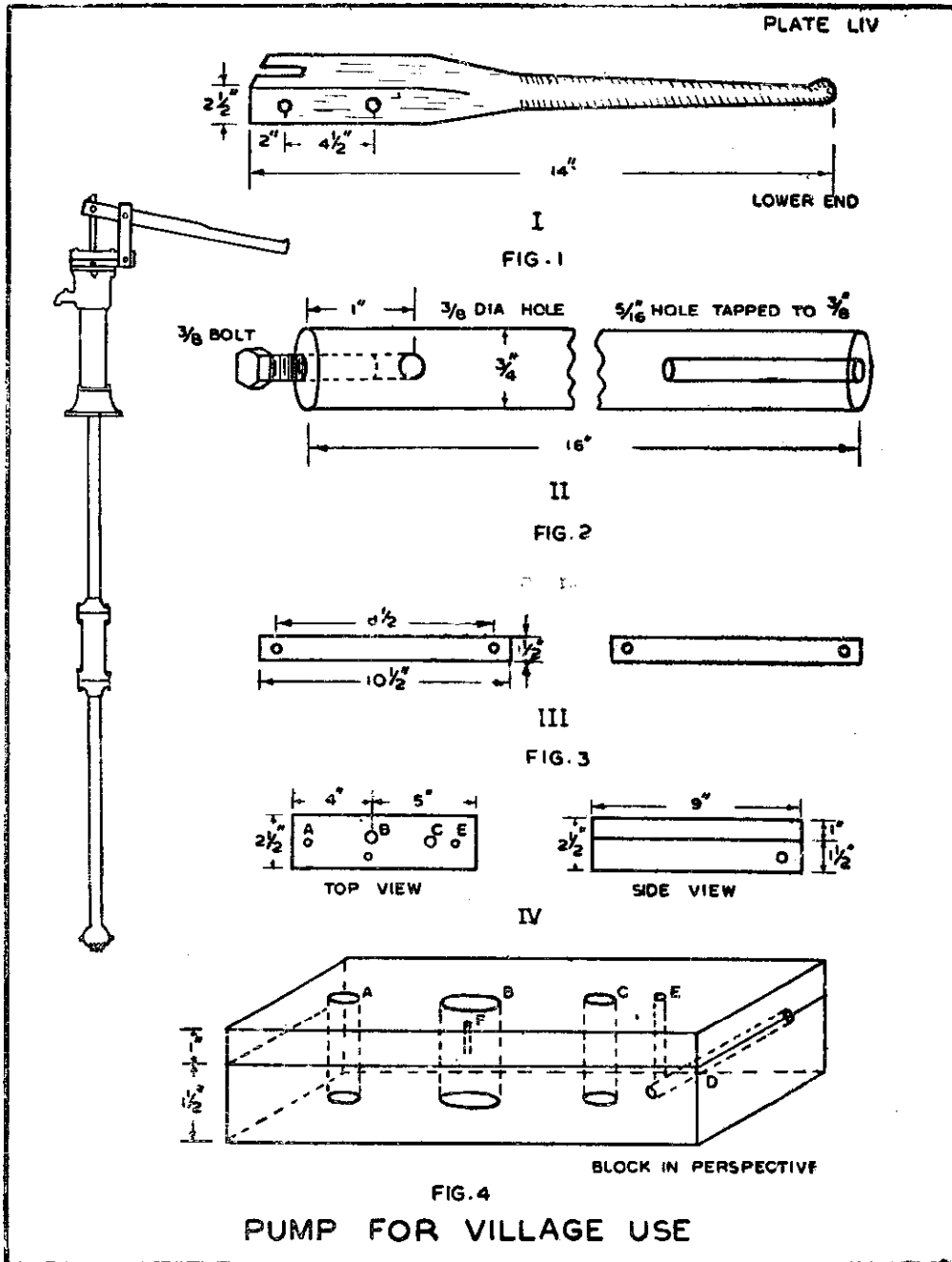

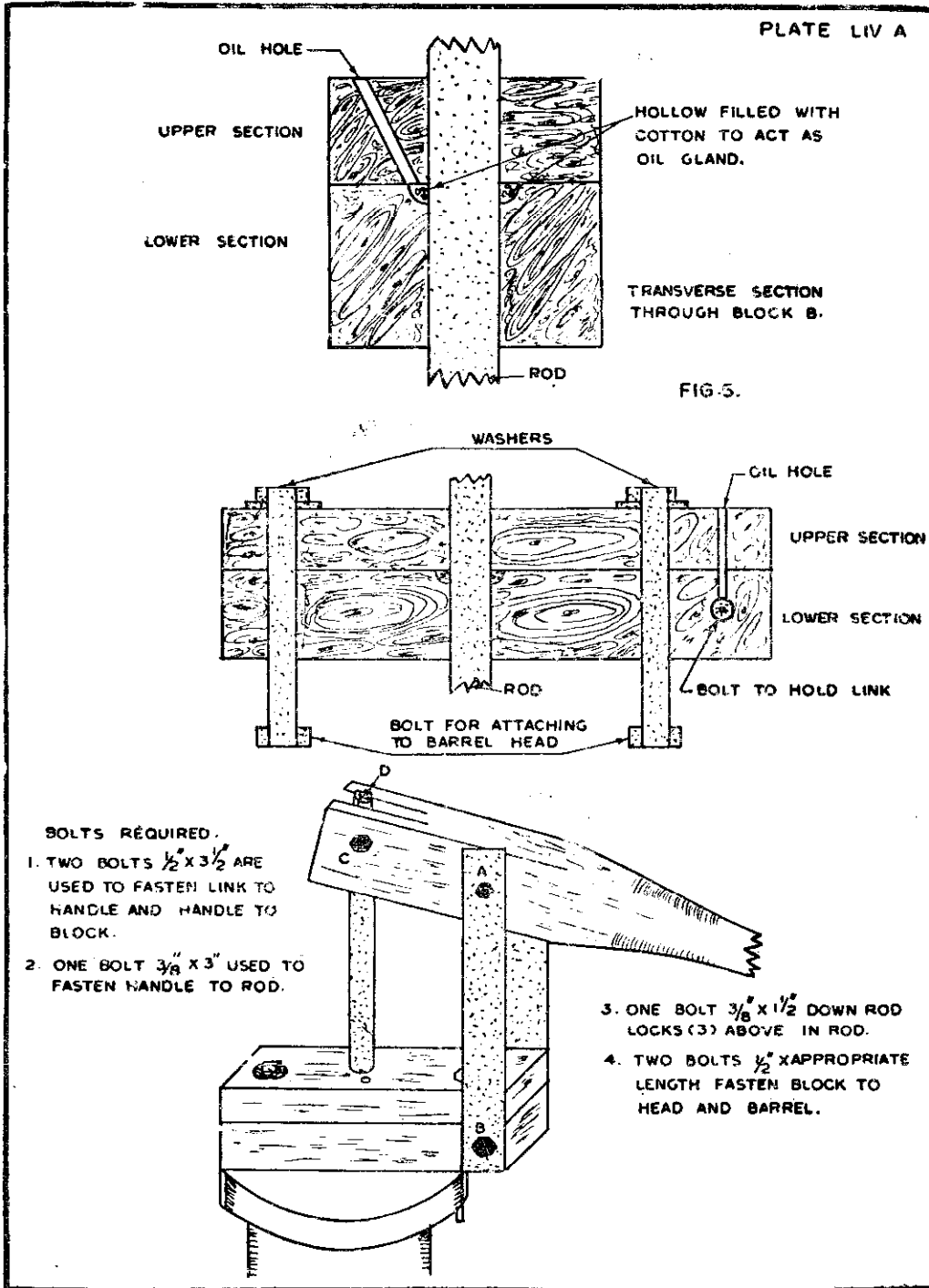

SHOLAPUR-TYPE PUMPHEAD

(Figures relate to Plates LIVB, LIVC and LIVD)

Contact Agency : Robert Tayabji, UNICEF, 9, Jorbagh, New Delhi.

Introduction : A very successful pumphead was designed by War On Want Mission at Jalna, Maharashtra. It was further refined by Sholapur Well Service, Sholapur and UNICEF, and became known as Sholapur-type pump. This is a submergible type pump whose valve remains submerged in the water surface and is linked to the operating handle by means of a connecting rod. Therefore, it does not depend on the suction head of the water and can be made to draw water from any depth. UNICEF has further improved the pumphead of the Sholapur-type pump.

Description of the pump : A complete pump is shown in Plate LIVB. The main parts are the head, the water tank, the pedestal, and the casing pipe through which the connecting rod goes down to the surface of the water and gets connected to the piston with valve which draws water. When the handle is pressed down, the piston goes up and allows the water to get into the casing pipe. After a few operations of the pump the water is drawn up to the water tank from where it comes out through the spout. Since the water volume on both the sides of the piston is balanced, no extra effort is required to operate the handle and it works smoothly and easily.

Sholapur-type pumphead : All pumpheads employ mechanisms to transfer the movement of the handle to the connecting rod, and thence to the piston and valve. Traditional pumpheads have a complex arrangement of levers, pivots and sliding parts, which must be cleaned and oiled regularly. In the Sholapur pumphead, a totally enclosed mechanism has been provided which uses heavy-duty roller chain, thus making it more durable and improving the reliability and efficiency of the pumphead. The essential features of the pumphead are the three parts, which are as follows :

- (i) The *head* which contains the handle and working mechanism.
- (ii) The *water tank* or reservoir, which ensures a steady flow of water from the pump and thus helps to prevent spillage and waste.
- (iii) The *pedestal or stand*, which supports the water tank and head. The pedestal is made from steel pipe and is thus lighter and sturdier than the cast iron bodies of traditional designs. The pedestal has three projecting legs which are anchored in the cement of the platform. (Fig. 2, Plate LIVC)

Installing a pumphead : In installing a pumphead, the pedestal is first fitted over the casing pipe of the tube-well. The three legs are then embedded in a cement foundation. Cement fills the space between the casing pipe and the pedestal and hardens there. This ensures that waste water cannot enter the tube-well and contaminate it. (Fig. 3, Plate LIVD). The handle is at a convenient height for the operator, the pivot being about 102 cms. (40") above the platform.

Hand pump conversion head: Most handpump breakdowns are caused by mechanical failures of the moving parts. The cast iron body of the Sholapur pumphead seldom needs replacement as it has no moving parts. Its purpose being merely to support the mechanism above. It is possible to change the pumphead of a traditional design by a conversion head of the Sholapur designs. Conversion heads incorporate the Sholapur mechanism which is more efficient, rugged and reliable than the conventional type. The UNICEF and the Sholapur Well Service have prepared drawings and specifications according to which the conversion heads can be manufactured easily. The handpump repair and substitution of a conversion head entails the following :

- (a) Installation of conversion heads on an ordinary pump
- (b) Construction of platforms and drains
- (c) Occasional replacement of other components, such as cylinders, pistons and washers

Price : (1) Approximate cost of conversion is as follows :

	Rs.
Cost of conversion head	300
Cost of new platform and drain ..	250
Cost of new cylinder, if needed ..	250
	<hr/>
Total ..	800

- (2) Installing a complete Sholapur-type pump will cost Rs. 1,500/- in addition to the cost of boring.

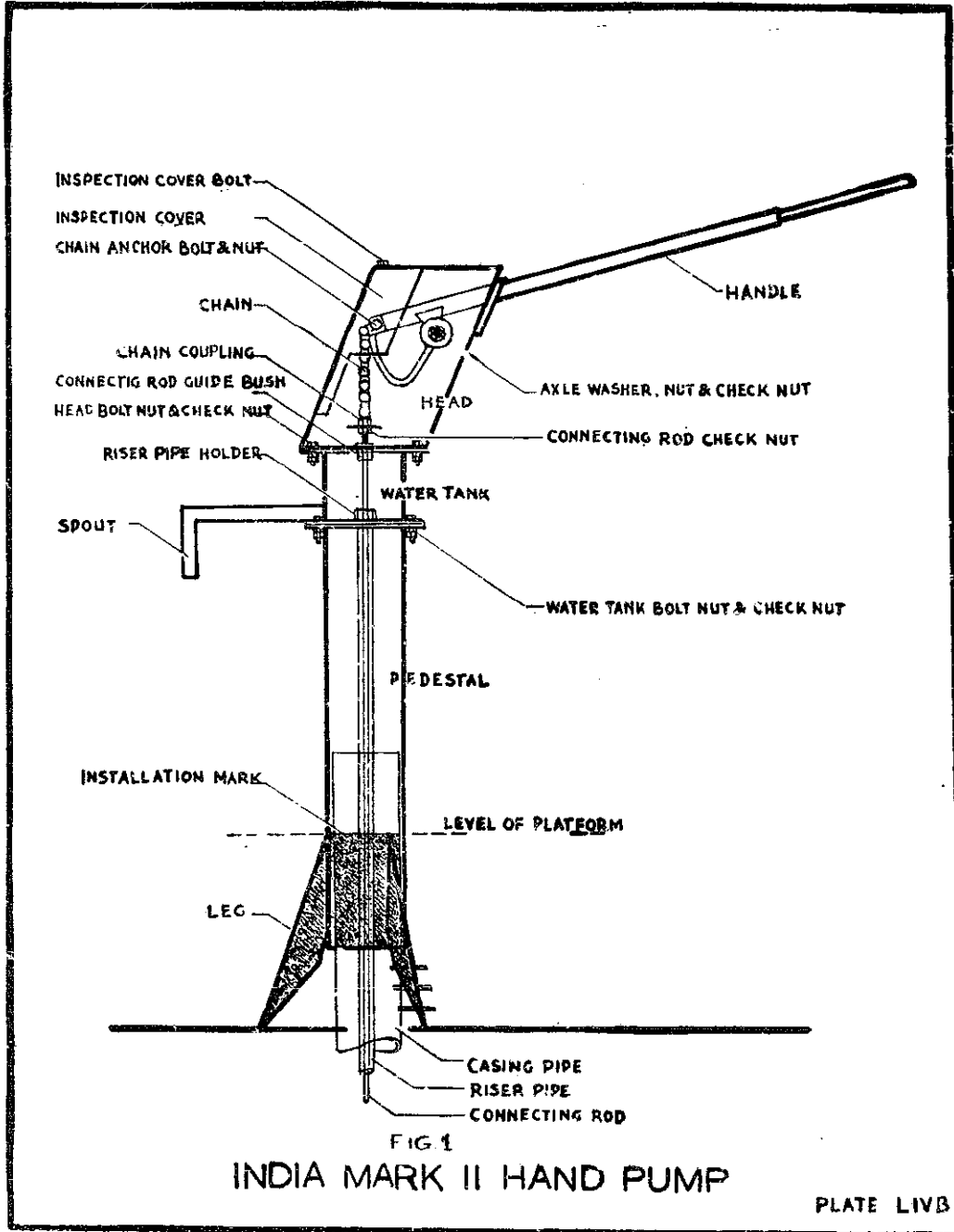

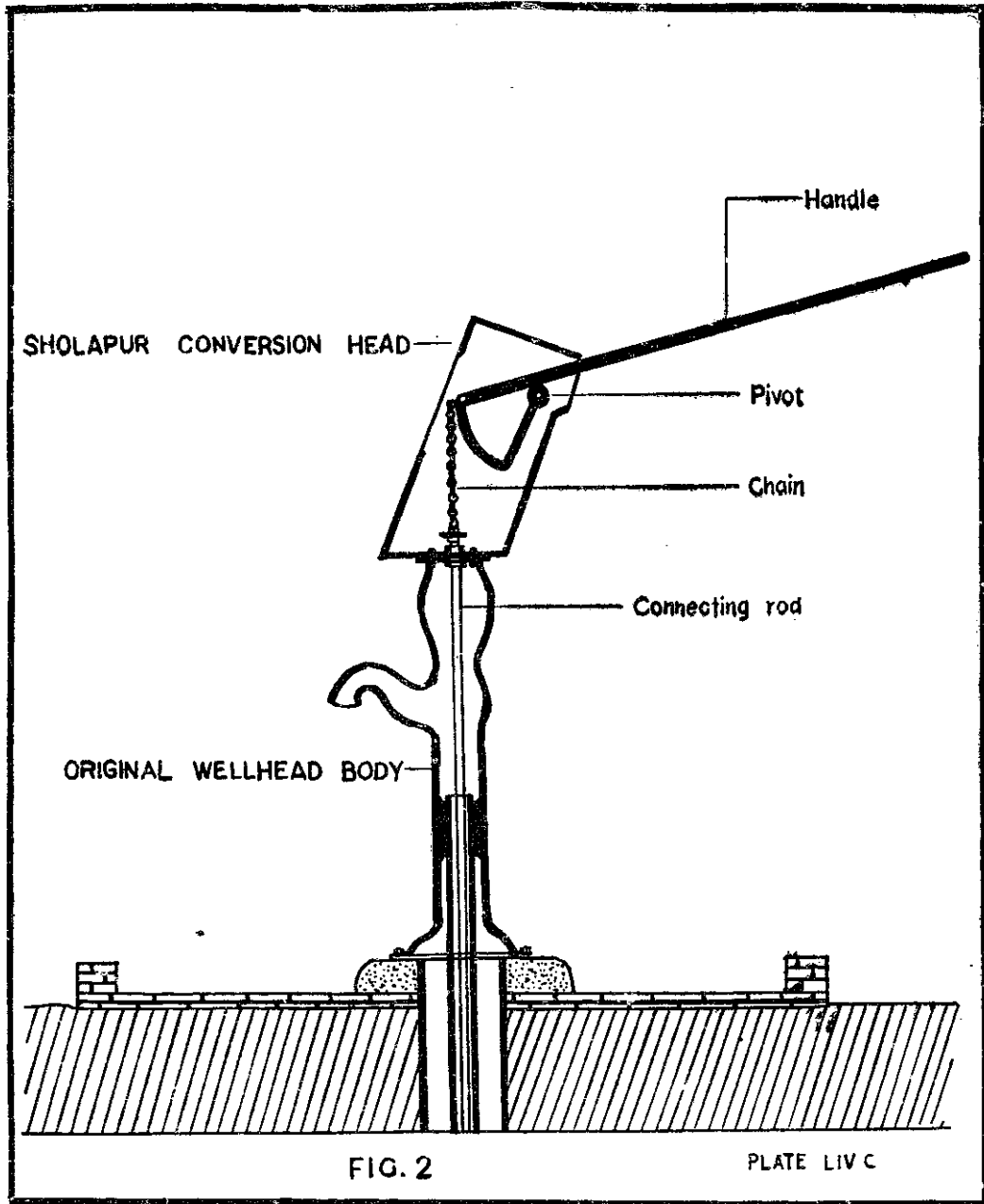

INSTALLATION OF SHOLAPUR HANDPUMP

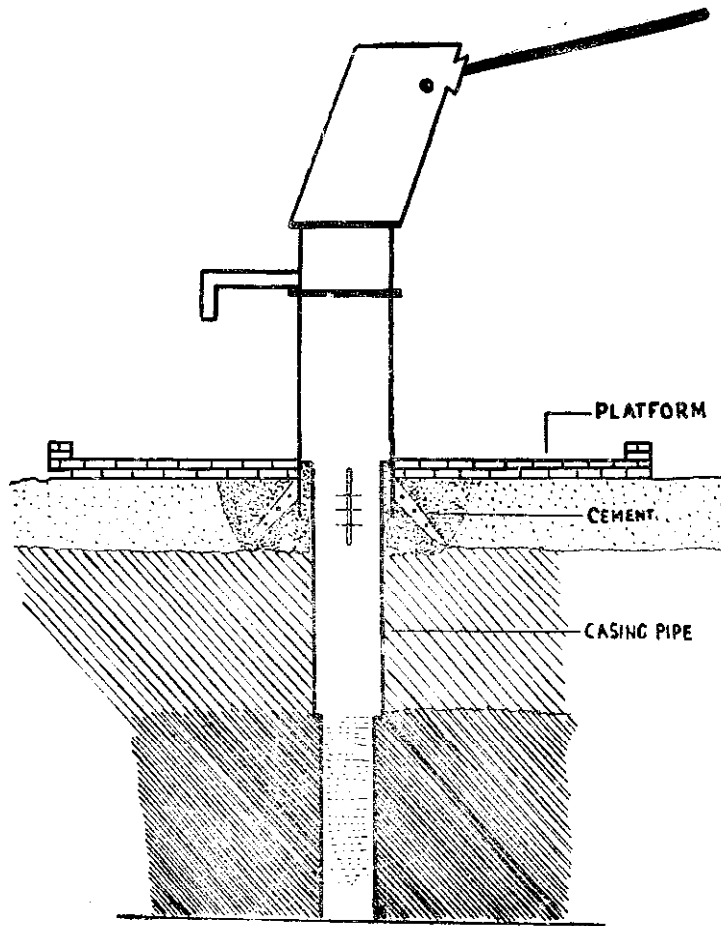

FIG. 3

PLATE LIV D

HYDRAULIC RAM

(Figures relate to Plate LV, LVA)

Introduction : Automatic hydraulic ram is used for pumping water. This is mostly useful for hilly areas where water falls through a large head. The ram pumps a small fraction of the water that flows through it to a level that can be much higher than the original source. The principles are explained in Fig. 1. This ram can only be used in places where there is a steady and reliable supply of water with a fall sufficient to operate the ram. Its advantages are as follows :

1. It does not need any additional power source and there are no running costs.
2. It has only two moving parts, and these are very simple and cheap to maintain.
3. It works efficiently over a wide range of flows.
4. It can be made using simple workshop equipments.

Designing the ram : The most commonly used ram operates on a flow from the source between 7 and 16 liters per minute and can pump upto a height of about 150 meters. The amount of water that such a ram can pump for different supply and delivery heads can be calculated from the table prepared by Blake Hydram. The ram can pump upto $3/4$ of the volume of water, mentioned in the table.

Example : Supply head = 4 meters
Delivery head = 30 meters

The ram will pump atleast $(1.15 \times 1000 \times 3/4) = 860$ litres of water per day.

Pumping rates for ram pump based on Blake Hydram table is given in Table 1.

If it is found that the ram installation is not large enough to pump the amount of water needed, a duplicate ram alongside of the original ram can be constructed. The delivery pipes can be either separate or the same delivery pipe may be used for a battery of several rams. (Fig. 2).

The drive pipe is really the most important part of the ram installation. It carries the water from the source to the ram and contains the pressure surge of the water hammer. The dia. and length of the drive pipe is very important and the ratio of length to dia. for good performance is not more than 500.

The delivery pipe can be made from any material and should have an internal bore of 20 mm. The water from the ram can be pumped for great distances provided that the delivery head is high enough.

The head of the tank must be large enough to hold enough water in reserve to supply the needs during periods of peak demands. It is better to fit an overflow pipe to the tank to lead the waste water in the garden.

Construction of the ram: The ram illustrated in the figures has a drive pipe bore of 30 mm. The ram body is made from pipe fittings of 50 mm. internal bore.

- (a) Impulse valve is made by welding a 50 mm. thread pipe junction on to the valve plates centrally over the 30 mm. dia. wheel as shown

in the figures 5 to 5 c. This leaves a lip inside the pipe connection about 10 mm. wide all round which acts as a seating for the impulse valve washer. File or rub and smooth the valve plate over the valve setting area to prevent wear on the valve washer. The two elongated wheels each 6 mm. dia. on the valve plate are to hold the valve spring.

- (b) Valve spring is made from strips of mild steel, 650 mm. long, 30 × 2mm. for the cross section marked out and drilled as shown in the figure. Bend the spring to shape around a 50 mm. pipe with the bend centre line on the strips in the position as shown in the figure. This sets the spring with the drill hole in correct position. Bolt the spring on to the valve plate which has elongated holes to allow the impulse valve stem to be adjusted for correct seating.
- (c) The impulse valve itself is made from a 6 mm. dia. bolt, tube and washer which is assembled through the valve plate to the valve spring.
- (d) Finally add spring tension and the valve stroke adjusting bore, to allow the ram to be tuned for maximum efficiency. The impulse valve assembly can be removed from the ram for maintenance by just unbolting the spring, then unscrewing the pipe connector and the valve plate. A better, but more complex, impulse valve can also be made as shown in Fig 3 to 3d

Making the delivery valve : The delivery valve prevents the pumped water from flowing back into the ram after the pressure impulse has ended. It is, therefore, a non-return valve which can be made easily by welding or brazing a cut and drilled piece of 3 mm. steel plate into the tube of 50 mm. pipe connector.

The plate is cut to shape and filed smooth to fit exactly into the end of the pipe connector and welded or brazed in position. A rubber washer is attached to the plate and bolted into the position. The washer must be flexible to allow the water to pass easily but must be firm enough to support the water pressure from the air chamber.

The cupped washer above the rubber valve holds the valve in place.

The air valve is made simply by drilling a small hole below 1 mm. in dia. in the side of the pipe connector and below the delivery valve. This is partially blocked by a fine wire split pin which moves with pressure changes in the ram to keep the hole open and allow air to enter. The air valve is placed in the opposite side to the delivery pipe outlet, otherwise the air entering the air chamber is likely to escape into the delivery pipe. It is, of course, essential that the air feeder valve is located below the delivery valve.

The air chamber is made by cutting 1 meter length of 50 mm. dia. water pipe and threading each end. One end is screwed into the delivery pipe T-junction pipe fitting, and the top is sealed with a cap.

The mounting legs are made from any available scrap strip iron and drilled, bent and bolted around the ram body. The legs can be bolted to the ground when the ram is assembled at the site, if it is meant as a permanent fixture.

Assembling the ram at the site

1. The pipe fittings are assembled using plenty of pipe joint compound. They are firmly screwed together and adjusted for the correct position in the ram assembly. They must be completely free from leaks.

2. The impulse and delivery valve must move freely and when closed, sit evenly on the valve plates.

3. Set the ram level on the mounting legs at the required site and attach the drive and the delivery pipes to it. These pipes are flushed with clean water before connection.

4. The drive pipe should be laid as straight as possible with no sharp bends.

5. The inlet to the drive pipe must always be submerged, or air will enter the pipe and prevent the ram from working.

How it works : A labelled diagram of a typical working ram installation is shown in Figure 1.

Water flows down the drive pipe from the source and escapes out through the impulse valve. When the flow of water passes through the impulse valve, it is fast enough. This flow and the upward force on the valve causes the valve to shut suddenly, halting the column of water in the drive pipe. The momentum of stopped column of water produces a sudden pressure rise in the ram, which will, if it is large enough, overcome the pressure in the air chamber on the delivery valve, allowing the water to flow into the air chamber and then upto the header tank.

The pressure surge in the ram is partly reduced by the escape of water into the air chamber. The pressure pulse rebounds back up the drive pipe producing slight suction in the ram body. This causes the delivery valve to close, preventing the pumped water from flowing back into the ram. The impulse valve drops down, water begins to flow out again and the cycle is repeated.

The ram is tuned to pump the greatest amount of water possible and this usually occurs when the ram is repeated or beats 75 times each minute.

Selection of site for the ram : It is necessary to know if the ram is capable of pumping the amount of water one needs or whether a larger ram is needed. The flow of water at the source is measured to see if it is enough to operate the ram.

Most rams will work at their best efficiency if the supply head is about 1/3 of the delivery head. The difference in the level between the source and the ram and between the header tank and the ram could be measured by using usual surveying instruments.

Maintenance of the ram : It is essential to prevent dirt from entering the drive pipe or dry leaves from blocking its entry. So it may be necessary to provide a grating at the off-take from the river or stream supplying the water in order to keep back floating leaves and a sump should be provided at the feeder tank to collect silt.

The maintenance tasks which must be carried out are likely to be as follows :

- (a) dismantling the ram to remove dirt
- (b) clearing air locks in the pipe system
- (c) adjusting the tuning; tightening bolts which work loose
- (d) changing the valve rubber; adjusting the seatings of valves
- (e) keeping the inflow to the drive pipe free of leaves, dirt, etc., cleaning filters and gratings.

The maintenance required is not very frequent but it is better if a local technician is trained in adjustment and tunings, etc., who can have a look at least once a week.

TABLE 1
DAILY PUMPING RATES FOR RAM PUMP (litres of water)

Supply Head (metres)	Delivery Head (metres)											
	5	7.5	10	15	20	30	40	50	60	80	100	
1	400	200	150	80	70	50	30	20				
2		550	390	250	200	130	80	60	50	30		
3			650	450	320	220	150	130	100	70	40	
4				650	430	300	200	150	130	90	60	
5				750	550	370	300	250	200	120	90	
6					700	450	350	300	250	150	120	
7						550	410	320	270	200	150	
8							450	370	300	250	150	
10							600	450	400	300	230	
12							750	550	470	350	280	
14								650	550	400	330	
15									620	470	370	
18									700	520	420	
20										600	450	

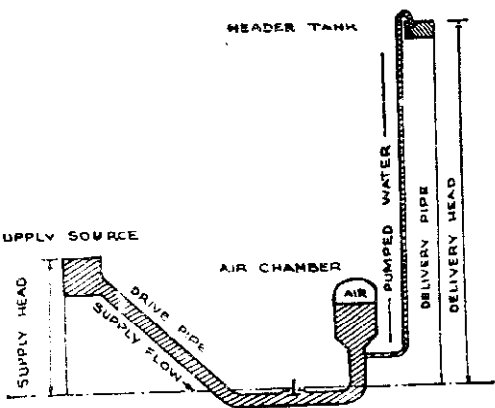

FIG.1

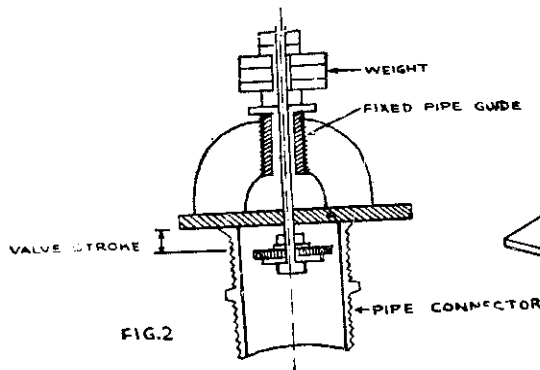

FIG.2

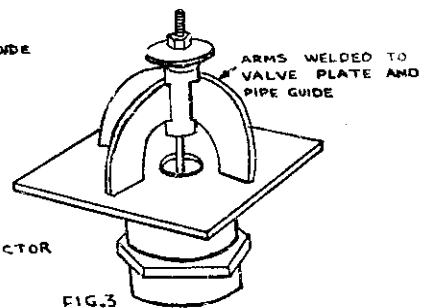

FIG.3

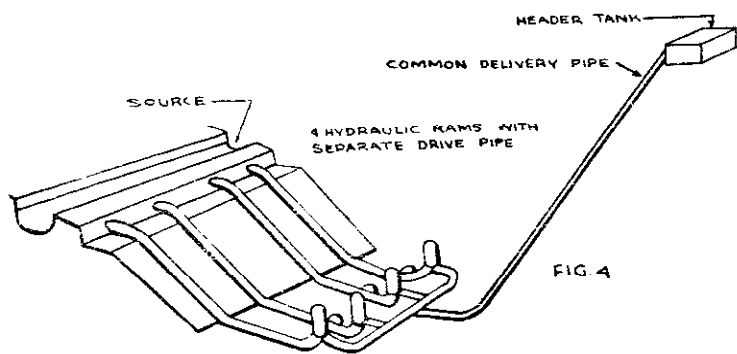

FIG.4

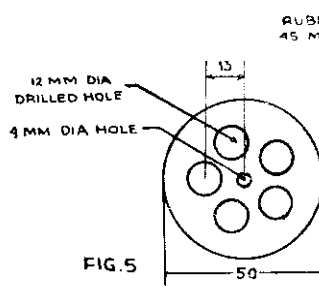

FIG.5

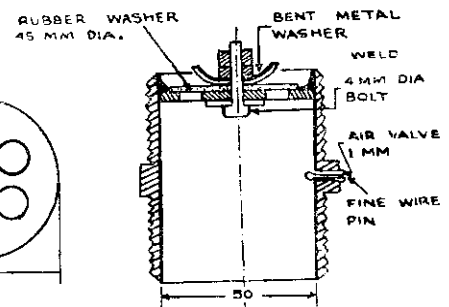

FIG.6

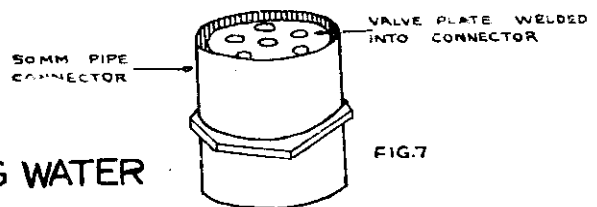
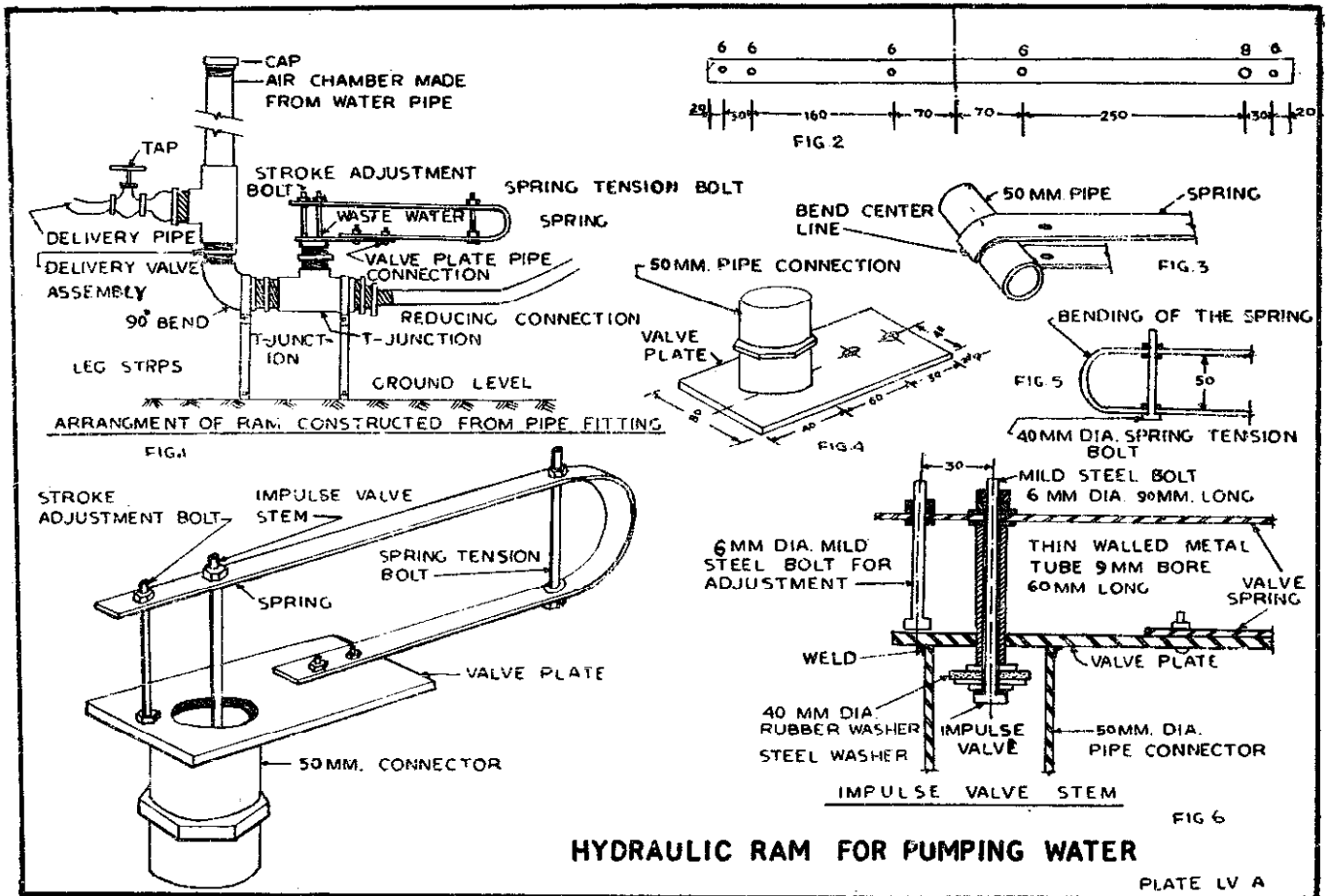

FIG.7

HYDRAULIC RAM FOR PUMPING WATER

PLATE LV



HYDRAULIC RAM FOR PUMPING WATER

PLATE LV A

HAND OPERATED SUCTION PUMP

(Figures relate to Plate LVI)

Contact Agency : Allahabad Polytechnic, Allahabad

Introduction : There is a great need for a low lift pump which can pump water from small ditches, tanks and rain water collection from low lying areas. In villages, people generally use baskets, which are operated by two persons, by ropes tied to two ends.

Construction : The design and drawing of the pump is shown in the figure. It is operated by two persons, working the levers on either side. The water comes out with great ease. The valve washer is made of specially formulated rubber, but this can be replaced by truck or car inner tubing. Except for the suction and the delivery pipes all other parts are made of iron sheet.

It can lift water from a maximum depth of 20 ft.

Price : Rs.500/-

HAND OPERATED SUCTION PUMP

ALL DIMENSION ARE IN cm.

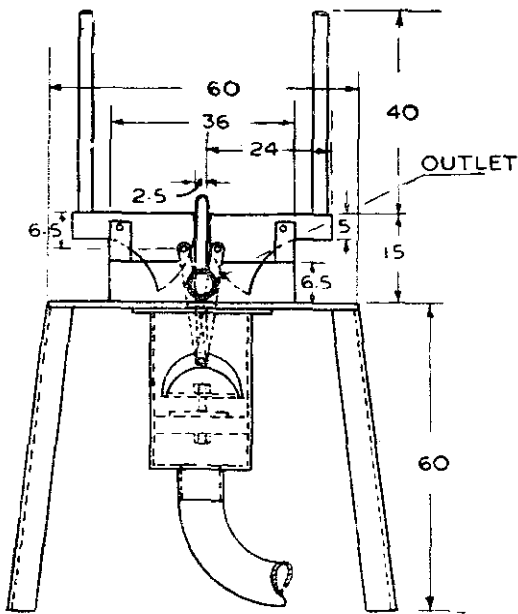

FRONT ELEVATION

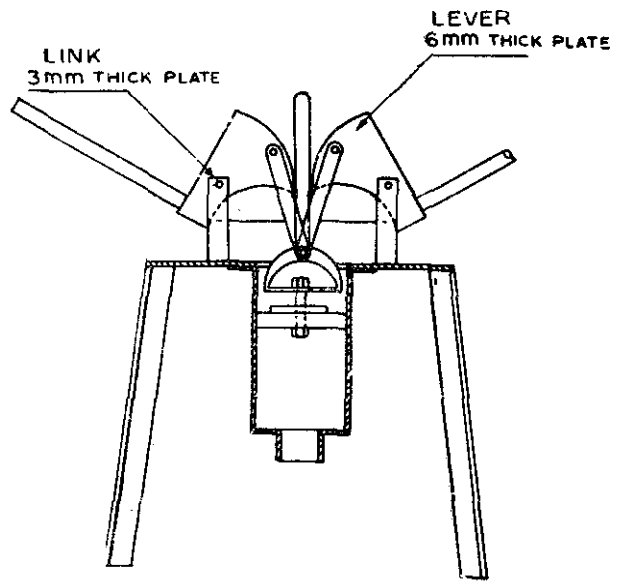

SIDE VIEW

PLATE LVI

GOBAR GAS PLANT

(Figures relate to Plates LVII, LVIIA LVIIIB, LVIIC)

Contact Agency : 1. Khadi and Village Industries Commission, Irla Road, Vile parle, Bombay.

2. All State Khadi Boards.

Introduction : Gobar gas plants or bio-gas plants need no introduction these days. It is one of the most publicized technology. If used imaginatively it can revolutionize the life in rural areas.

How operated : Gobar gas plant (cowdung methane gas plant) is the name applied to a plant which subjects organic wastes like cow dung, night soil, poultry sweeps, agricultural bye-products, grass, shrubs, leaves, water haycinth and other wastes to fermentation in the absence of air. After the plant has been installed, the only work to be done is to feed the slurry (waste materials and water in the ratio of one to one) into the digester and the methane gas is automatically produced.

Nature of product: (i) Methane gas is used for cooking, lighting and running engines and (ii) manure.

The gas has a calorific value of 550 B.Th.U. and burns with a blue non-luminous flame at a temp. of 1000°F. Manure has a high fertility value and 50% extra manure is obtained saving loss due to oxidation.

Coastruction

The plant can be fabricated in a village, if facilities of blacksmith and sheet metal working are available. Trained persons from Khadi and Village Industries State Boards are available to help the construction work.

It mainly consists of two parts :

- (a) *Digester* : It is a sort of "well" constructed of masonry work, dug and built below the surface of ground level. The depth is between 12' (3.5 meters) and 20' (6 meters) and diameter varies between 4' (1.2 meters) and 12 (3.5 meters) according to the capacity of the plant. The well has a partition wall in the middle dividing it into two semi circular-compartments. Two slanting cement pipes serving as inlet and outlet pipes reach the bottom of the well on either side of the partition wall and have their openings on the surface inside the inlet tank (slurry pit) and outlet tank.
- (b) *Gas holder* : It is a drum constructed of mild steel sheets. It fits like a cap in the mouth of the well, where it dips in the slurry and rests on a ledge constructed inside the well for this purpose. The drum collects the gas which bubbles out from the cattle dung slurry in the digester. The drum rises as the gas is collected in the gas holder drum. The gas thus accumulated, flows out through the pipe provided at the top, whenever the tap is opened.

- (c) *Pipe lines and oven* : The gas can be led to the kitchen or can be used for gas lamp whenever required within a distance of about 10 meters (30 ft). The pressure is very small 3" (7.5 cm.) to 6" (15 cm.) water column, but it is adequate to press the gas into the kitchen stove or gas lamp.

Cost	<i>Size of plant in cu. meter gas/day</i>	<i>Estimated cost in Rs.</i>
	1.6 (60 cu. ft.)	1,500.00 approx.
	2.75 (100 ,,)	2,000.00 ,,
	4.00 (150 ,,)	3,000.00 ,,
	5.50 (200 ,,)	4,000.00 ,,
	6.75 (250 ,,)	5,000.00 ,,

Large capacity plants upto 2500 cu ft. are also available for commercial use. In some cases subsidy and loan are given by the Khadi and Village Industries Commission.

Due to the efforts of Khadi and Village Industries Commission as well as of the state governments, more and more gas plants are being installed in the villages. There are still some snags in its popularisation. During winter months, the gas formation is greatly reduced hence the farmers fail to get the required quantities of gas from their plants. Research work is in progress on this problem and Appropriate Technology Development Association is collaborating with the Central Drug Research Institute, Lucknow for an effective solution of this problem.

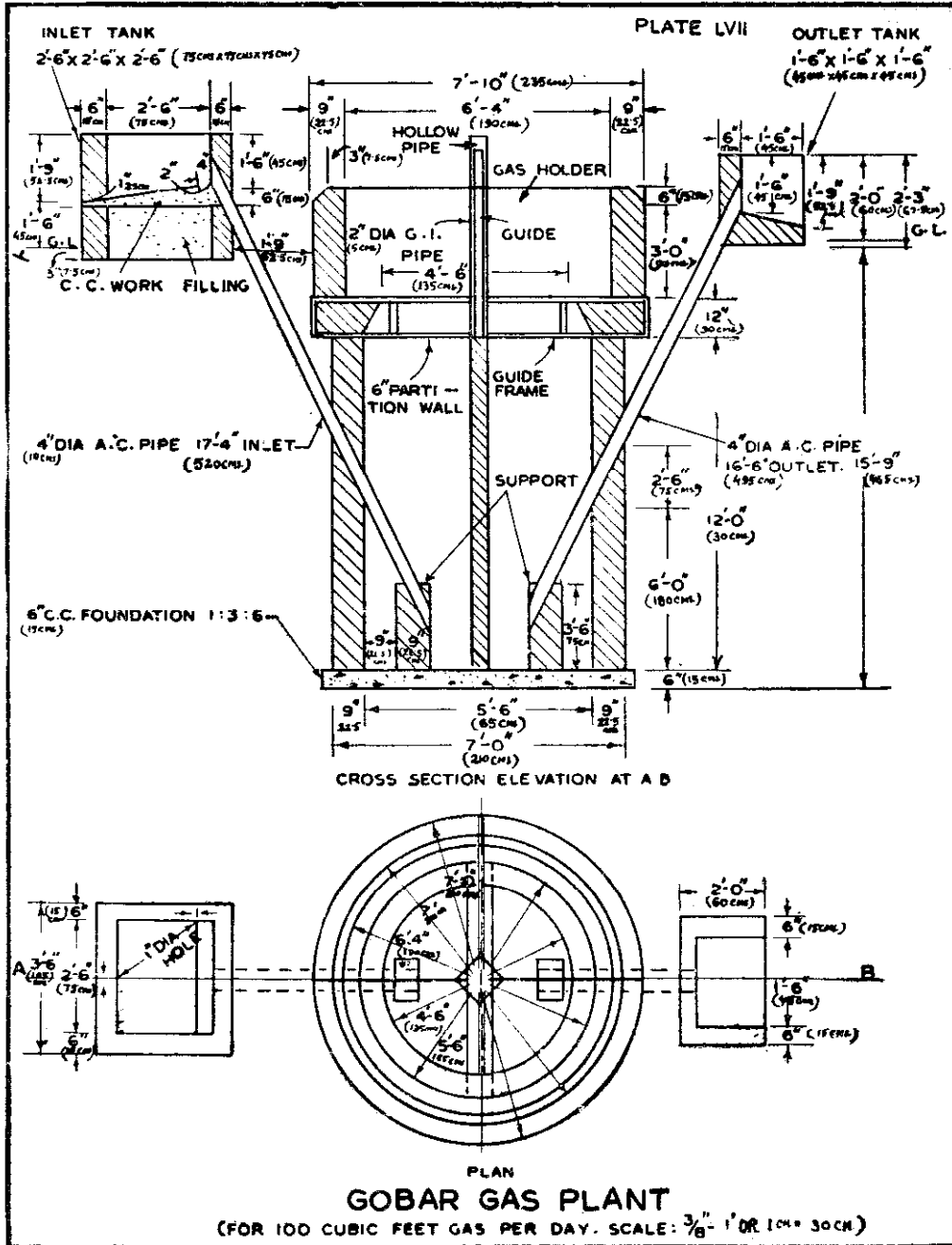
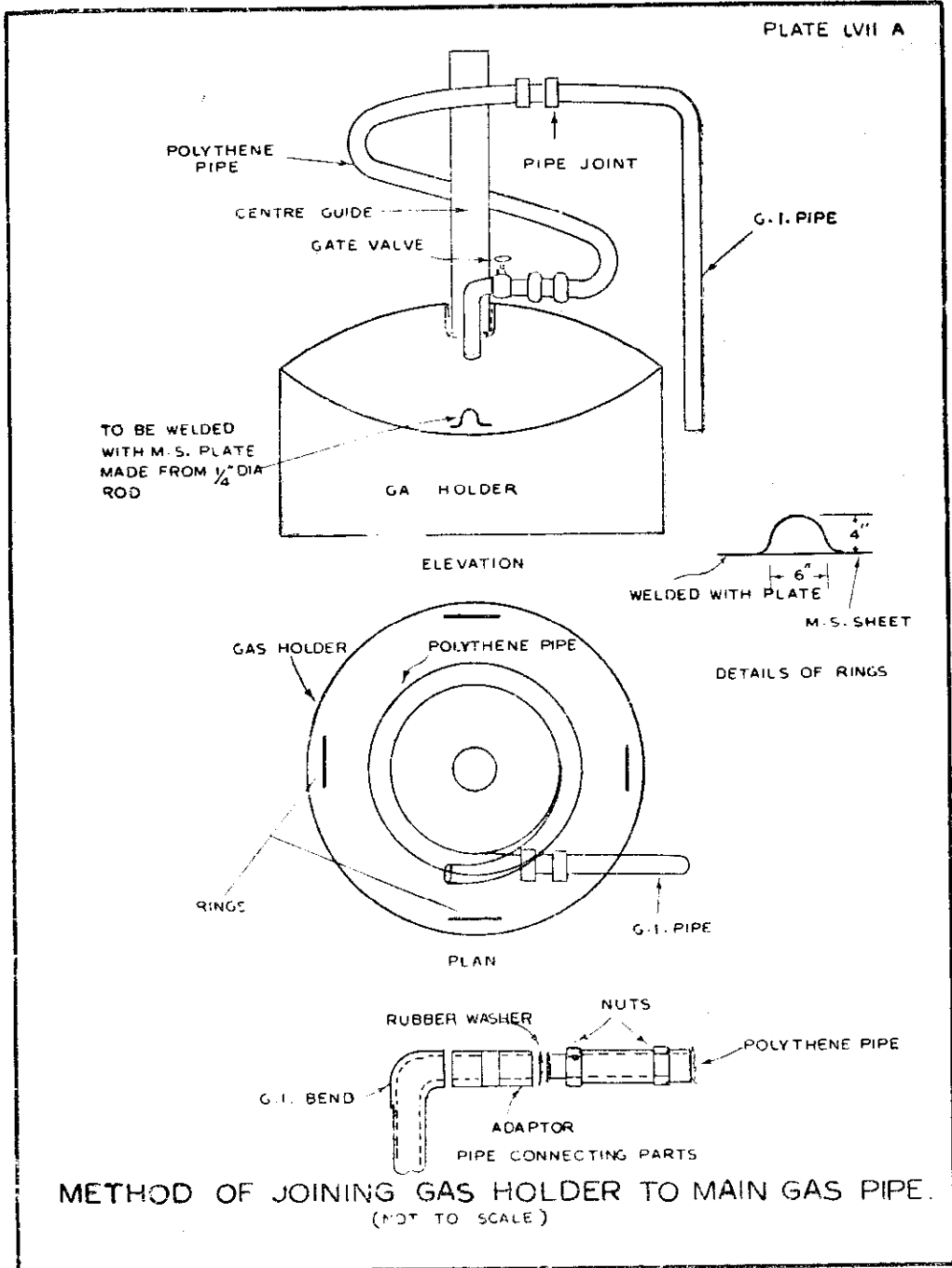

PLATE LVII A



BIO-GAS PLANT ACCESSORIES

(Figures relate to Plate LVIIIB)

Introduction : The bio-gas produced in the bio-gas plant is not pure methane and has got many impurities. The typical composition can be as follows :

CH ₄ (Methane)	68.8%
CO ₂ (Carbon dioxide)	29%
N ₂ (Nitrogen)	1%
H ₂ (Hydrogen)	1%
CO (Carbon monoxide)	0.1%
O ₂ (Oxygen)	0.1%
H ₂ S (Hydrogen sulphide)	Trace

The calorific value of the gas is mainly dependent upon methane (CH₄) and therefore it is desirable to eliminate other gases specially carbon dioxide (CO₂), which is present in considerably high proportion. This reduces the calorific value of the bio-gas per unit volume. Similarly, the traces of H₂S present can also create nuisance in corroding the metal appliances. The two accessories used for these purposes are described below and should form indispensable part of a bio-gas installation.

Filtration tank: When produced from cow-dung, there are only traces of hydrogen sulphide in the bio-gas. But if other biological wastes are added, the percentage may increase. Its presence may lead to corrosion of the appliances in which the gas is used, specially if it is used for running engines. The filtration tank shown in Fig. 1 was designed at the Gobar-Gas Experimental Station, Ajitmal Etawah, U.P. and was found quite successful in experimental stages. The gas is passed through a vessel which is fitted with iron filings and ferric oxides which absorbs H₂S. The gas, free from H₂S comes out from the outlet pipe.

Lime water scrubber : This apparatus is shown in Fig. 2. The gas is passed through lime water from the inlet pipe, and the agitator is worked frequently, so that the CO₂ is absorbed in the lime water. Bio-gas, free from CO₂ goes out through outlet pipe. The lime water has to be occasionally changed.

PLATE LVII B

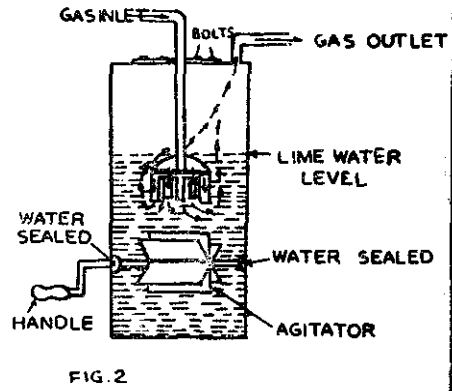
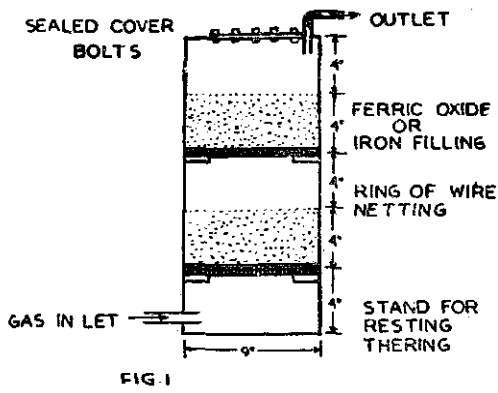
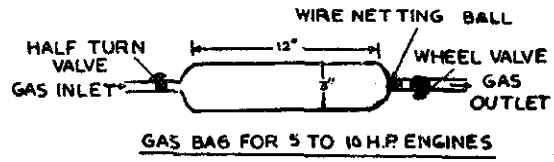
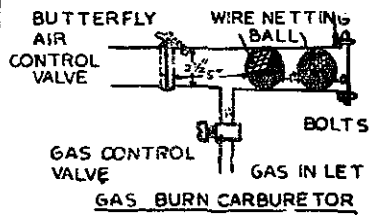

FILTRATION TANK

LIME WATER SCRUBBER

GOBAR GAS PLANT APPLIANCES

(Figures relate to Plate LVIIC)

Introduction : When the gas comes out of the gobar gas plant, it may be used for various purposes. It can be used for cooking, lighting, heating, and running engines, etc. Cooking and lighting are the most widely used purposes for village homes which are chronically short of fuel. For all this work, we need appliances. These appliances have been designed and standardised by the Khadi and Village Industries Commission to suit various purposes and are described below :

Burner : 9 cu. ft. of air is needed for the complete combustion of every cu.ft. of gas. The improvised burners at home, made out of tin boxes, do not meet these requirements and consume extra gas unnecessarily. The standard burner approved by the Khadi and Village Industries Commission is shown in Fig. 1 and 2. The burner should be used according to the amount of food to be cooked. For one person's meal, a small burner shown in Figs. 1, which uses only 6.0 cu. ft. of gas per hour is sufficient but for a family of five persons, the burner shown in Fig. 2, using 16 cu.ft. of gas per hour is more appropriate.

Gas lamps : Khadi and Village Industries Commission has designed a very suitable lamp in which the mantle used is similar to one used in petromax. They are available in one mantle lamp or two mantle lamp, as shown in Figs. 3 and 4 respectively. They use approximately 3 cu. ft. of gas per mantle per hour, and give a beautiful blue lambent light. To increase the life of the mantle, the following precautions should be taken:

- (i) The lamp should be fixed firmly in one place and should not be moved around.
- (ii) It should be protected from water.
- (iii) The pressure of the gas should remain uniform.
- (iv) It should be protected from moths getting inside the lamp.
- (v) The glass should be cleaned carefully.
- (vi) The lamp should be lighted carefully.

PLATE LVII C

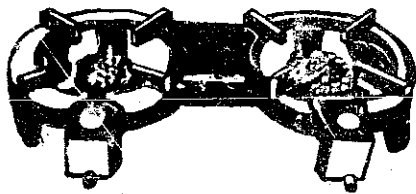

GOBAR GAS BURNER
FIG. 1

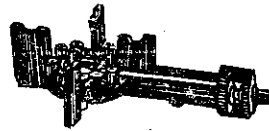

BIO GAS BURNER
FIG. 2

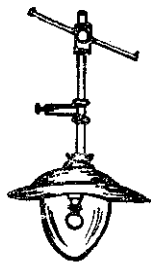

BIO GAS LAMP
FIG. 3

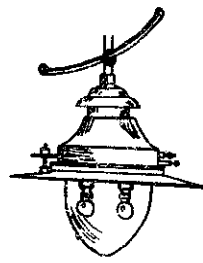

BIO GAS LAMP
FIG. 4

GOBAR GAS BURNER & BIO GAS LAMP

Household and Domestic

INTRODUCTION

To make people comfortable in their own surroundings and environments, changes have to be brought about in their homes. For this reason, there is a need for developing home living technology. Housewives are exposed to hard labour for attending to their ordinary household chores. Burning of cowdung cakes and firewood in the hearths, preparation of food, washing of utensils, etc. are time consuming, laborious and monotonous processes. In the western countries, electrical gadgets have been developed to facilitate the work of housewives in the preparation of food, washing of utensils, dishes, clothes, and sweepings, etc. It may not be possible for the village homes in India to make use of these appliances for a long time to come. However, if systematic work is done in this field, several gadgets could be introduced which could greatly simplify the household work. Improved 'choolhas,' solar cookers, solar water heaters can be used with great benefit, reducing the monotony and drudgery of work inside the house. Such additions in homes can be instrumental in changing their attitude to life and making them forward looking and progressive thereby bringing benefit to the community as a whole.

For this reason, household and domestic appliances are included as a separate section in this directory and some of the innovations in this field have been described. This only illustrates that there is need for developing other suitable gadgets for domestic use and the engineers, scientists and technologists can apply their minds on other household problems.

SOLAR WATER HEATER

(Figure relates to Plate LVIII)

How operated : Solar water heater helps in raising the temperature of water with the sun's rays during summer as well as in winter months. The system of its operation and construction is given below :

Water is filled in both, i.e. storage tank and the water heater. As the sun heats the water, the hot water rises to the top of the storage tank and the cool water from the bottom of the tank moves into the heater. The water temp. in winter at 3.30 p.m. can go upto 135°F (55°C) and in summer upto 149°F (65°C). The water can be used for washing utensils, and clothes and also for taking bath in winter.

The water is drawn from the tap provided in the storage tank. If the storage tank is insulated with felt or straw, the temp. would rise even further.

Construction

(i) The solar water heater is made of two galvanised sheet of 35' × 70' and 16 swg. They are bolted to each other with about 28 galvanised bolts of $\frac{1}{4}$ " dia. and 1" long to prevent the sheets sagging in due to the weight of water. The two sheets are separated by a distance of 1". Mud brick support is provided to the heater to make it inclined at an angle of 20° to face the sun's rays vertically. The heater is painted with dull black paint.

(ii) A 70 litre capacity galvanised sheet metal with a removable lid, is used for storage. The top of the storage tank is connected to the top of the heater either with flexible hose pipe or galvanised iron pipe. Similarly the bottom of the tank is connected to the bottom of the heater.

Tools and materials

- (i) Galvanised sheet metal—two pieces 35' × 70' 16 s.w.g.
- (ii) 70-litre galvanised sheets metal tank, with removable lid and 1" hose connector, one near the top and one near the bottom.
- (iii) Galvanised sheet metal pipe : 4 pieces, 2" long and 1" in dia. for connectors.
- (iv) Rubber hose pipe : 2 pieces, 50" long and 1" dia
- (v) Galvanised bolts : 28, $\frac{1}{4}$ " dia. and 1" long
- (vi) Metal washers for $\frac{1}{4}$ " bolts : 56
- (vii) Rubber washers for $\frac{1}{4}$ " bolts : 56
- (viii) Mud bricks
- (ix) Black paint
- (x) Tinsmiths tools—hammer, anvil, soldering equipment, tinsnips
- (xi) Hand drill and $\frac{1}{2}$ " bit
- (xii) Screw driver
- (xiii) Pliers and $\frac{1}{2}$ " spanner

Cost : Approximately Rs. 200

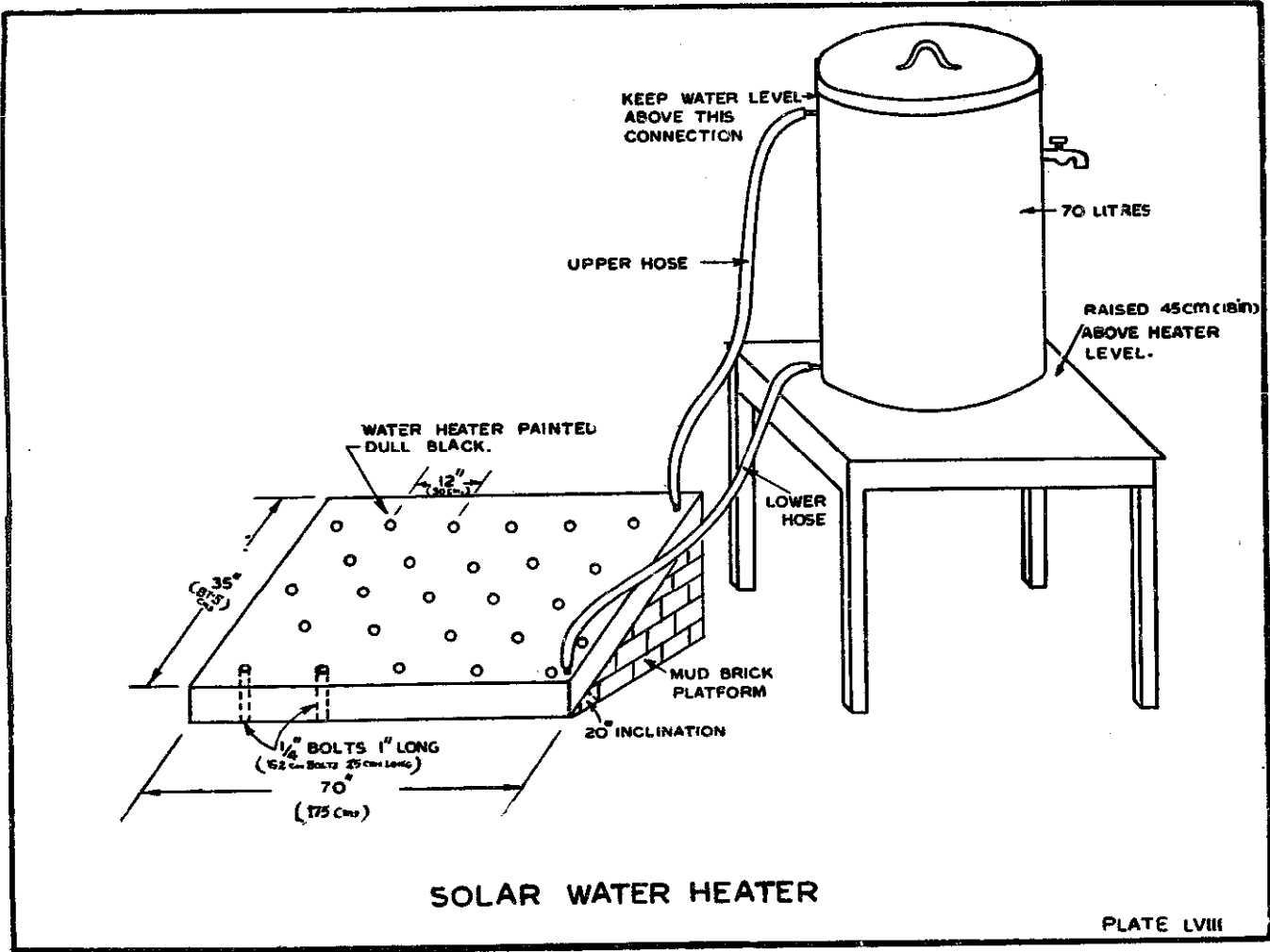

HAND WASHING MACHINE

(Figures relate to Plates LIX, LIXA)

Contact Agency : VITA Inc., 3706 Rhodes Island Ave., Mt. Rianier, Md. 20822, U.S.A.

Introduction : Washing of clothes in India is carried out either by primitive method of beating the clothes on the stone or the highly sophisticated method of process steam laundries. Housewives and professional washermen have to labour hard to wash clothes, the main processes being soaping, washing and tumbling. These time consuming and monotonous processes could be eliminated if some manually operated mechanical device were introduced.

Mechanical washing machines employ a tumbling or agitating action and incorporate a device for changing the water, which is automatically operated by electricity. An elementary washing system, using a tumbling action machine, could be made with little cost and only moderate skills. Timing and control of the washing cycle may be done manually provided an operator is in attendance during the washing.

Method of construction

(i) *Outer drum* : A 55-gallon oil drum in good condition with no rust inside has to be cut all round on the line shown in the sketch. The rough edges are then filed smooth, straightened and painted. The whole of inside of the drum is painted with good enamel paint.

Wooden strips are attached all round the cut edges, so that wood edge is 1/8" above the metal edge. Two 'skids' are also attached to the bottom of the drum with screws driven from inside.

(ii) *Inner drum* : The wooden inner drum is made with smooth strips of wood $\frac{3}{4}$ " with circular wooden ends. A detachable portion is provided, which enables dirty linen to be loaded into the wooden drum. The overall dimensions of the wooden drum should be such as to allow it to pass through the hole cut into the oil drum. Brass screws are used for assembling, taking care that no screw protrudes from the surface of the wood. All screws with heads inside the drum must be countersunk well below the surface. The gap between adjacent strips should be between $\frac{1}{8}$ " and $\frac{3}{8}$ " depending upon the size of clothes to be washed. Half-inch diameter holes should be drilled all round to promote the flow of water.

(iii) *Shaft* : The inner wooden drum is made to rotate inside the oil drum. A shaft either of sturdy bamboo of 2" dia. or of steel tube is provided to pass through the bearings provided at both the ends of the oil drum, and a handle is attached at one end of the shaft. The shaft is secured firmly to the two ends of the wooden drum. It is better to use a 4 ft. length of the bamboo to start the assembly of the drum. Holes are cut in the centre of the end board of the wooden drum just large enough for the bamboo to be pushed in when the ends have been constructed. They are set at correct distances apart and final assembly of the drum commenced. After each strip has been properly secured in place, it is checked that the drum is not warping by making sure that the bamboo is free to rotate. Finally holes $\frac{1}{2}$ " in dia. for both are drilled carefully through the two and supporting members and through the centre of the bamboo at each end. The detachable portion of the wooden drum should be firmly held in place and at the same time be capable of being opened easily for loading and

unloading the wash. Strips cut from the motor car tube may be used to close the lid tightly.

The wood pieces of $4\frac{1}{2}'' \times 4\frac{1}{2}''$ with holes in the centre, for the bamboo to pass through and rotate easily, is bolted on the oil drum to work as bearings.

Assembly : The wooden squares are attached to their respective ends, using $\frac{3}{8}''$ dia. galvanised nuts and bolts. The correct length of bamboo is pushed through the bearing at one end, so that it just protrudes outside. Some assistance is now necessary to lift the wooden drum up and upto the oil drum and for holding it in correct position when the bamboo is pushed on through, until each piece engages properly in the holes in the ends of the wooden drum. The holes in the bamboo and end support of the wooden drum are lined up and $\frac{1}{2}''$ dia. galvanized bolts are inserted and nuts tightened up. The eight nuts holding the bearing are then tightened up. The wooden drum is turned slowly and nuts tightened evenly to avoid jamming. A handle is then attached to the longer piece of bamboo.

How operated : The linen to be washed, is loaded inside the wooden drum by lifting the top cover. The cover is then closed and the drum filled with water, preferably hot, heated by solar water heater. The cheapest soap obtainable will serve the purpose quite well, if a little borax and soda are available. It will be a matter of experiment to find the most suitable mixture to suit the water available.

The bamboo shaft is then turned by the handle, which rotates the wooden drum, and tumbles the linen inside and soaks them well with soap mixture and cleans them. The water is changed at suitable intervals.

A simple and cheaper washing machine can be built very easily as given in figures in Plate LIXA.

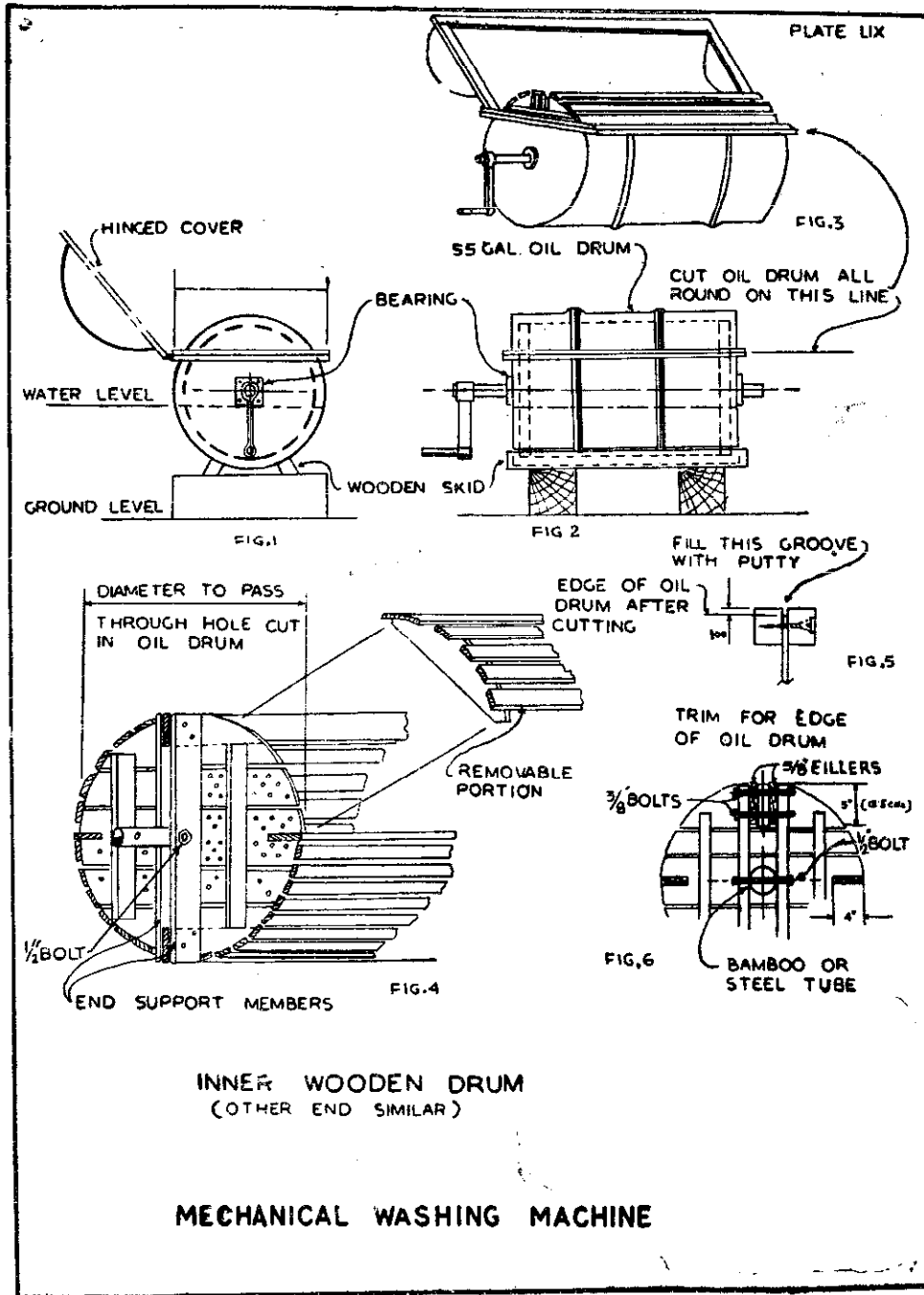
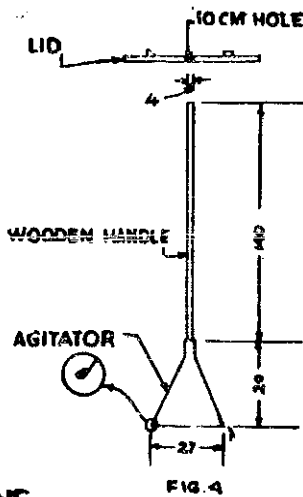
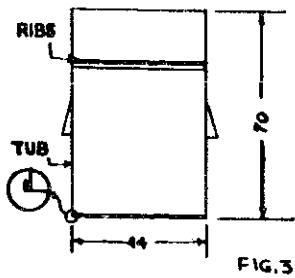
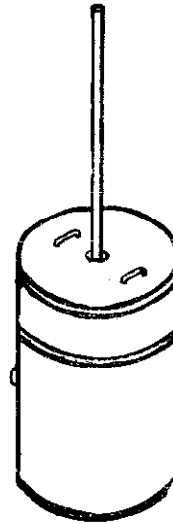
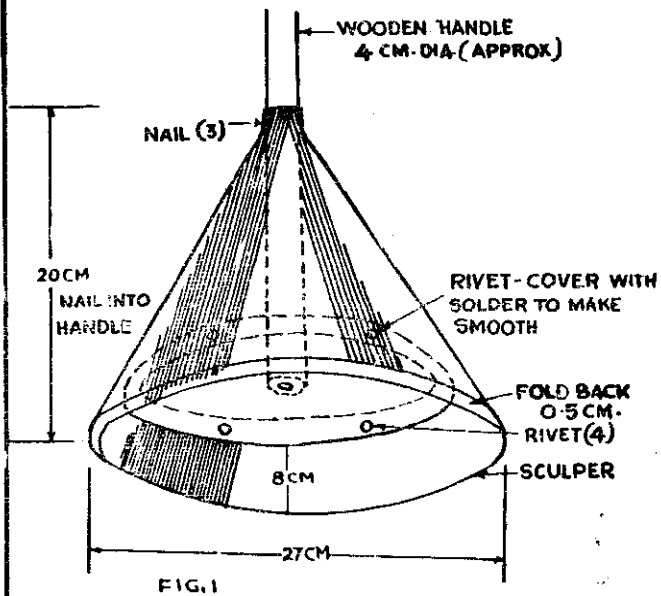

PLATE LIX A



HAND WASHING MACHINE

SOLAR COOKER

(Figures relate to Plates LX, LXA)

Contact Agency : Agricultural Tools Research Centre, Bardoli, Gujarat.

Introduction : A good effort has been made by the Centre for making solar cooker. Much remains still to be done to make the cooker perfect so as to attain a temperature of 100°C in order to ensure full cooking; but the method employed in its construction and operation deserves appreciation and can be further worked upon to perfect it.

Fuel is also a fundamental necessity like food; village women spend some time every day, collecting fuel. Fuel when purchased accounts for 10 to 15% of total expenses on food. Fuel when burnt produces smoke and thus spoils the house and utensils and affects the eyes. Industries use fuel. Forests are cut, coal and petroleum are taken out of the earth's bowel to be used as fuel. The prices keep on rising. A day will come when all the fossil fuel will be exhausted from the earth.

The solar energy is absolutely clean and available in abundance in India. Man has used this energy from time immemorial for making salt and drying clothes and various other things.

In India, on one sq. cm. surface, on an average, the sun radiates 450 calories of heat. But due to diffusion and dispersal this heat is not sufficient to cook meal. If, by some means, the diffusion and dispersal and the loss due to conduction and convection are stopped, and most of the heat is absorbed by an object, then we can use it as a substitute for fuel. The same principle has been used in the *solar cooker*.

Construction and design: The solar cooker is a sheet metal box with double walls. A double glass cover is fitted tightly on the box. Boxes containing food to be cooked are kept in the cooker in a similar manner as in the pressure cooker in the oven. The boxes are painted black. The sun's rays enter the cooker through the double-walled glass lid. The black colour of the boxes absorbs 15% of the solar energy and uses it for cooking the food. To minimise loss of heat through conduction, the space between the double wall is fitted with some insulating material. The tight fitting lid minimises heat loss caused by convection.

The wave length of the solar radiation is short. It thus enters the glass cover and heats up the interior of the box. But the heat radiation is of a longer wave length and, therefore, unable to come out of the glass cover. This minimises loss due to radiation. The design of the solar cooker needs maximum entry of sun's rays and minimum loss from inside. The inside temp. of the cooker remains 58° to 60°C above the outside temp.

Construction : The solar cooker has four important parts (i) inside box, (ii) outside box, (iii) cooking boxes, (iv) double walled glass cover.

(i) *Inside box* : This is the place where the cooking boxes are kept. 24 gauge galvanized iron sheet is required to make the inside box. The sheet is cut in the size required as shown in the figure. The height of the walls is 100 mm. The width of the upper wall is 30 mm. The box is folded as given in Fig. 1. The dimension of the inside box is determined by the size and number of

cooking boxes to be kept inside. It is better to prepare a template for the inside box, if the cookers are to be manufactured in quantity.

(ii) *Outer box* : The outer box can be made either of wood, steel or bricks. The inside box should fit properly inside, after giving insulation like saw dust, paddy husk or glass wool or thermocole. Fig. 3 shows the wooden frame of 180 mm. depth. The length and width should be equal to $D+80+80$ mm., so that, there should be 80 mm. space all round for filling the insulating material. The empty space is packed tightly with any insulating material and then the edge of the outer box and inner box is sealed airtight.

The inside box should be painted with dull black paint and the outside box with any colour to look presentable.

(iii) *Cooking boxes* : The cooking boxes can be made of any metal of 24 gauge. It should be of low depth. Aluminium or brass may be ideal from heat absorbing point of view, but the cost may be prohibitive. If made of iron sheet the boxes are painted dull black on the outside; the inside is kept clean and galvanised. Its height should not be more than 80mm.

(iv) *Double walled glass cover* : 50 mm. wide, and 20 mm. thick timber is used for making a frame of the size of the box. Two glass sheets are fixed one at the top and the other at the bottom at a distance of 20 mm. The frame is fixed to the outer body with hinges on one side; the other side is left free to be opened and closed according to will. Rubber bands are fitted all round either on the inside of the cover or on the face of the box, so that, when the cover is closed, it becomes airtight.

The completed solar cooker is shown in Figure 4.

- A—Inside box
- F—Outside box
- E—Double walled glass cover
- G—Glass sheets
- D—Hinges
- R—Cooking boxes
- W—Insulating material

How to operate: Rice, porridge, dal, sweet potato, leafy vegetables, etc. can be cooked and bread, cake, etc. baked in the cooker. The material to be cooked is kept ready with spices, onions, water, oil, salt, etc. and put inside the box.

Where to place the cooker : The cooker should be kept in sun out of the shadow, preferably on the roof or in the courtyard, where sun stays at least for 3-4 hours.

The limits

1. You cannot cook food, whenever you like. It must be cooked when the sun is there.
2. On cloudy days, the food cannot be cooked. Keep some alternative arrangement ready. (As you should to light stove when the gas cylinder is not available, using coal or wood fuel).
3. It takes more time than coal or wood fired hearth. But once the boxes are placed in position, there is no need to attend to them. When you are used to it, you save money and fuel.

The Appropriate Technology Development Association carried out a series of trials on the cooker and suggested that more research work needs to be carried out to further improve its efficiency.

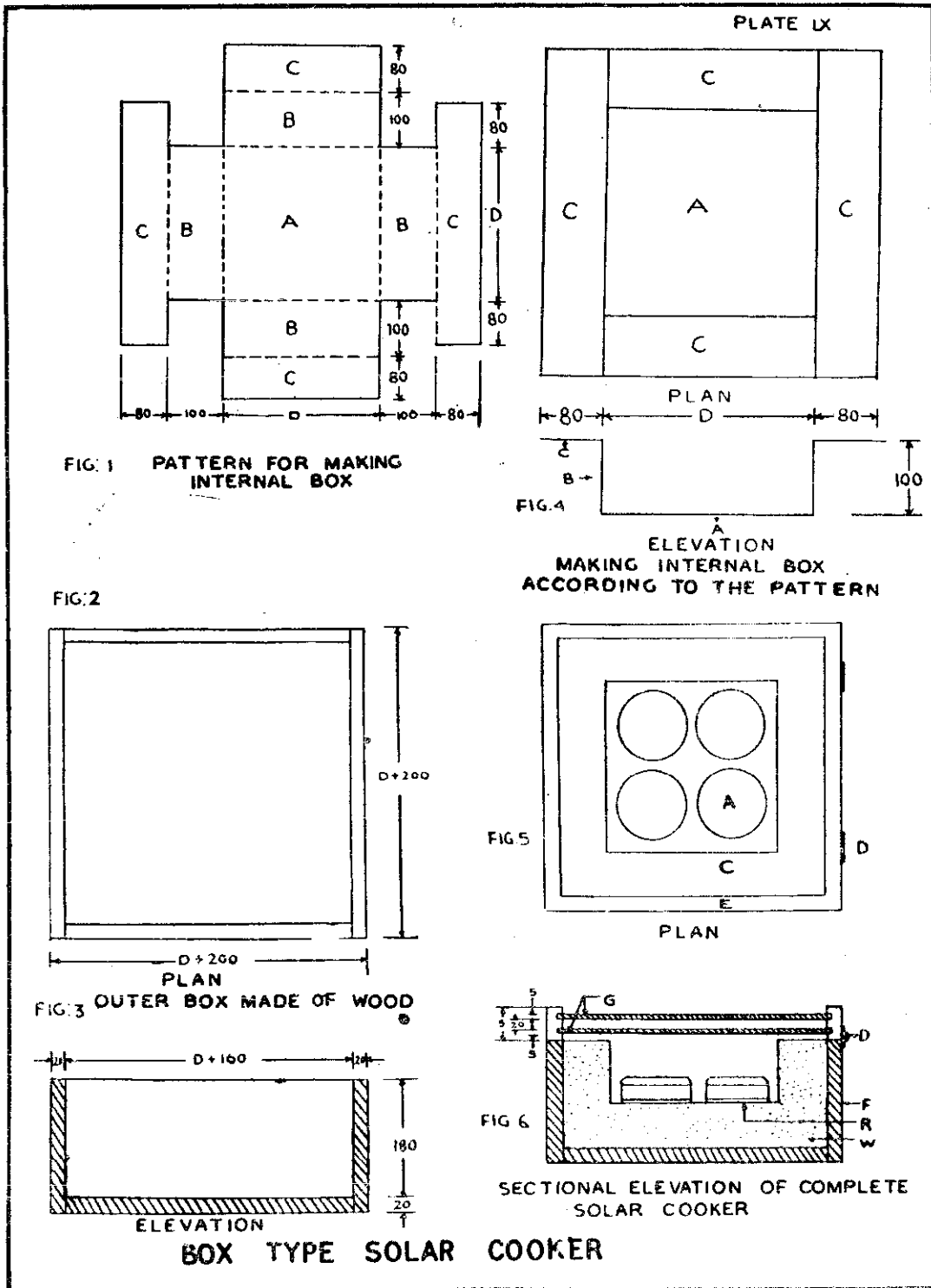

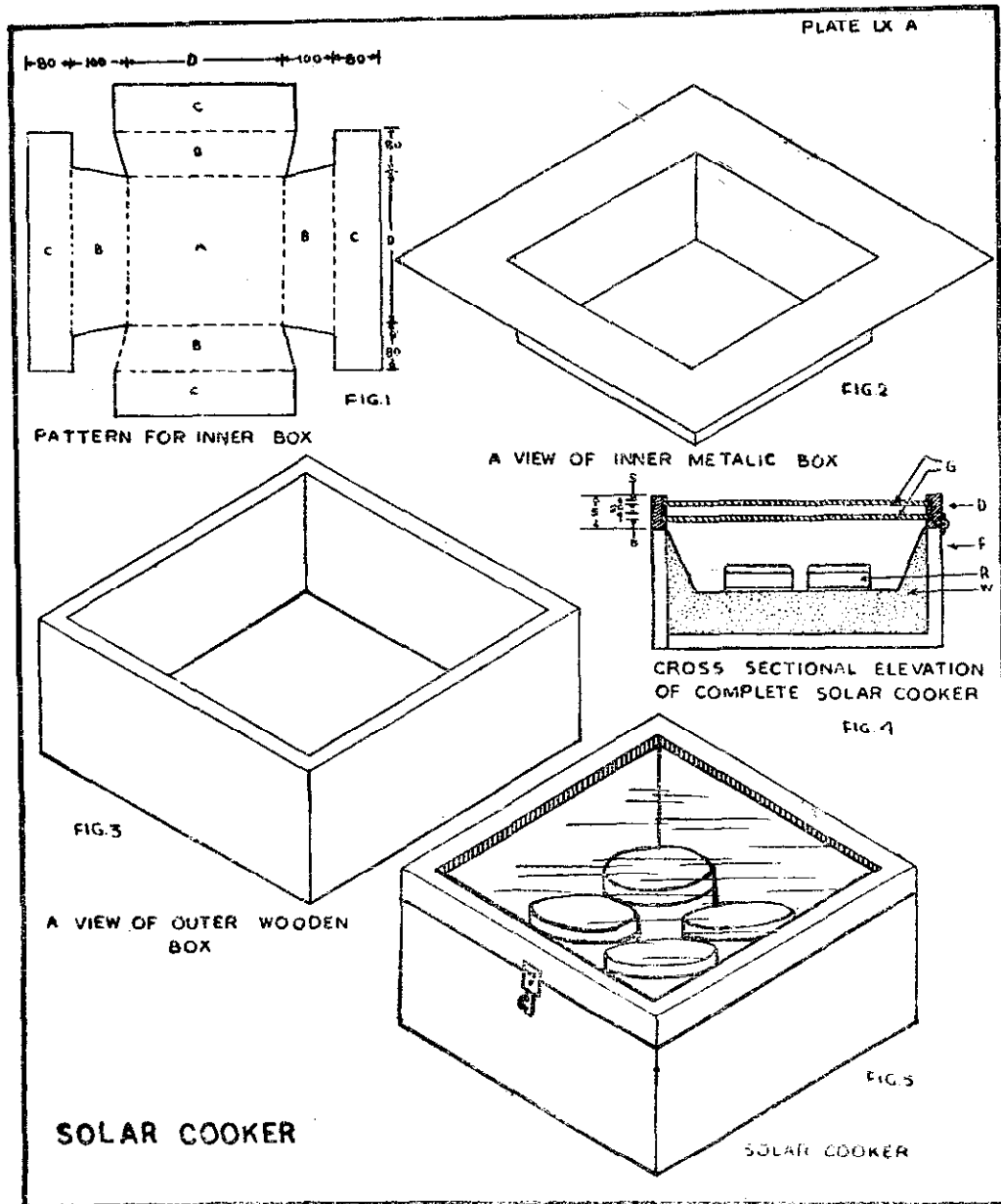

IMPROVED "CHULAH" FOR KITCHEN

(Figures relate to Plate LXI)

Contact Agency : National Buildings Organization, Nirman Bhawan,
New Delhi.

Introduction : Most of the common designs of 'chulah' used in Indian houses are using cowdung cakes, firewood, coal or coke as fuel, producing smoke which is a nuisance for housewives. Therefore, the lighting of oven in the home becomes the most dreaded of all the household jobs. With a little imagination and using improved design with a chimney, the 'chulah' can be made absolutely smokeless while burning coal or coke.

Description : It consists of two holes on which the utensils are kept. These are joined internally with the chimney holes, on which a damper is provided. Gratings made of 4" mild steel bars welded to a ring of mildsteel rod, are placed on the holes in which the fire is lighted. The hole at the time of lighting is covered by two 'tawas' (dish-like iron plate). The coal is put on the grating and lighted and the holes covered by the 'tawas'. The damper of the chimney is opened which induces draft and lights the fire quickly. When the fire is alight, the 'tawa' covers are taken out and the damper adjusted suitably to regulate the fire. The ash falls inside which can be taken out by means of holes with covers provided on the front side.

The cost of making this 'chulah' is about Rs. 50/-.

A number of other designs have been developed by various agencies; but further research work is needed to perfect suitable designs for different parts of the country which may effectively utilize the local fuel efficiently and eliminate the nuisance of smoke.

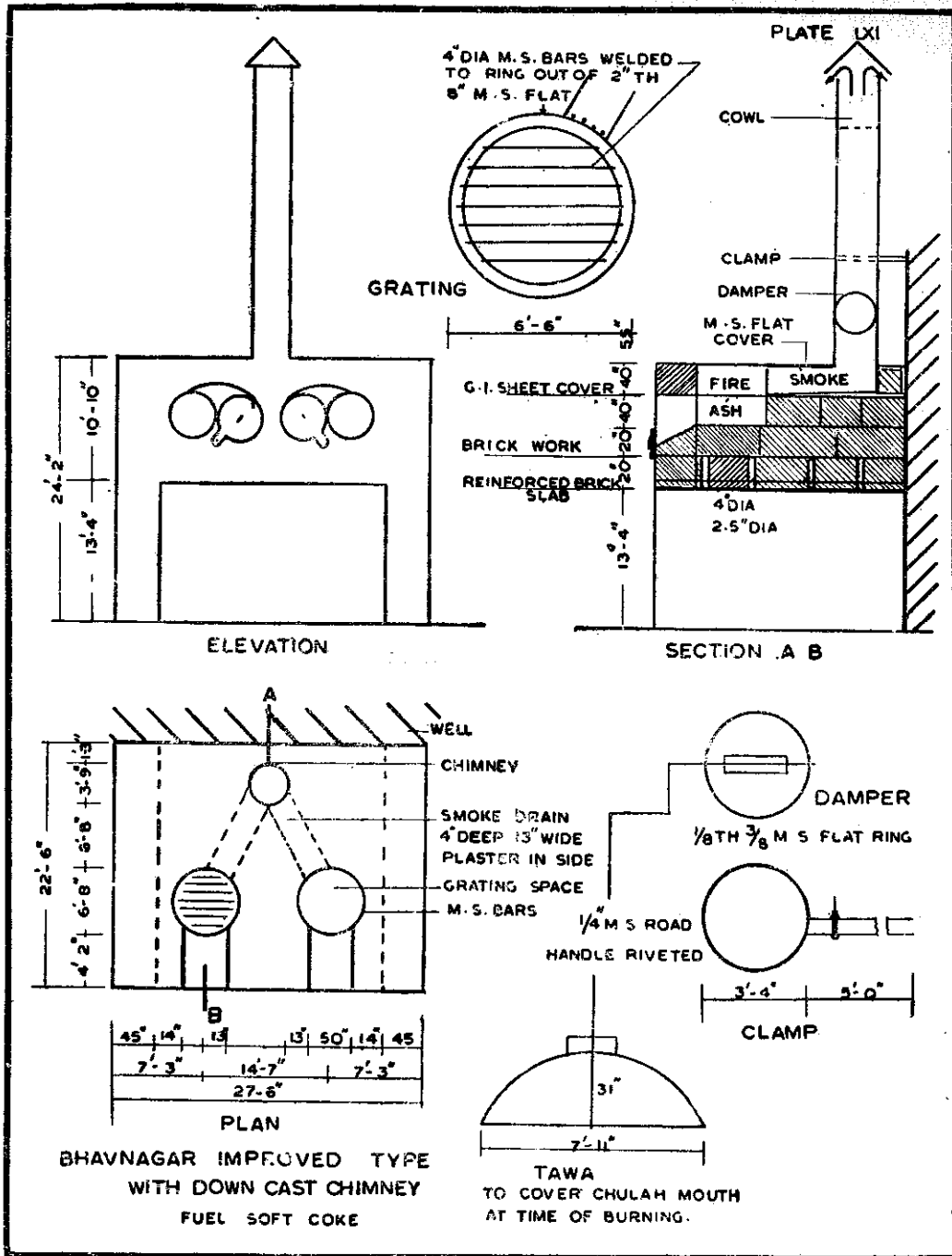

Housing and Construction

INTRODUCTION

Construction, which may include many other allied processes and programmes, is one of the activities which can be highly labour-intensive, and in which a large number of unskilled and semi-skilled workers can be employed with minimum capital investment in machinery and equipment. Constructions like bund or dam making, road making or building activities are sometimes started in drought or famine affected areas to provide employment to the people. If used imaginatively and simultaneously with several other productive activities in the villages, they can probably bring about a great improvement in the country-side. Construction and building, and other mass employment activities, like tree plantation, reclamation of fallow land, soil and water conservation programmes however have to be started as pump priming i.e., to add an extra income in the community and mobilise people for work. But the real productive activities lie in different fields, i.e., in producing consumer articles in the village itself for local consumption.

Since construction may become the starting point of the national reconstruction programme, it has to be carried out with great foresight, originality and sagacity. Appropriate technology, which is efficient and at the same time labour-using, instead of labour-saving, should be adopted. The use of materials and their treatment and fabrication have to be handled with great caution and care. Because of their high costs, concrete, glass, and iron and steel are not suitable materials for construction of houses in the rural areas. The mud and thatched houses are also not suitable, because they are damaged during rains, and can also catch fire easily. Appropriate technology suggests that cheap and easily available materials, should be used after making them waterproof, fire-proof and termite resistant. Appropriate small designs of houses are also needed which may be well ventilated and hygienic but should be of low cost.

In this section, some of the techniques and processes developed for improving construction activities with low capital investment have been described.

HOUSE FOR LOW INCOME GROUP

(Figures relate to Plates LXII, LXIIA)

Contact Agency : Rural Housing Cell, National Building Organisation,
Nirman Bhavan, New Delhi.

One-roomed house for landless labourer: Foundation consists of 6" lime concrete and brick work. Plinth is done in second class bricks and lime mortar. The superstructure consists of brick in mud-mortar. Lintel, door frames, shutterings are to be of local wood. Mango and mahua woods are generally used. Roofing consists of naria tiles and mangalore tiles over either split bamboo or hill bamboo on a layer of thatching by straws. The flooring is earthen (katcha) and is plastered with mud and cow-dung from time to time. The kitchen and bath-room are made pucca with 1/2" cement plaster (1:6) over 3" lime concrete. Walls are lime flushed and white washed. Bore hole latrine is provided*.

Cost estimate

	Rs.
1. Plinth area main building—192 sq. ft. at Rs. 4.16 per sq. ft.	800.00
2. Goat shed or poultry shed 30 sq. ft. at Rs. 1.50 per sq.ft.	45.00
3. Bore hole latrine	150.00
4. Hedging and drains	60.00
Total	Rs. 1055.00

Two-roomed house for marginal farmers

Cost estimate :

1. Plinth area main building—500 sq. ft. at Rs. 4.16 per sq. ft.	2,080.00
2. Bath room—25 sq. ft. at Rs. 2.50 per sq. ft. ..	52.60
3. Cattle shed and fodder shed 150 sq. ft.	262.60
4. Bore hole latrine	150.00
5. Hedging and drain.. .. .	75.00
Total	Rs. 2,620.20

*It would be preferable to install water seal latrines though they cost more.

PLATE LXII

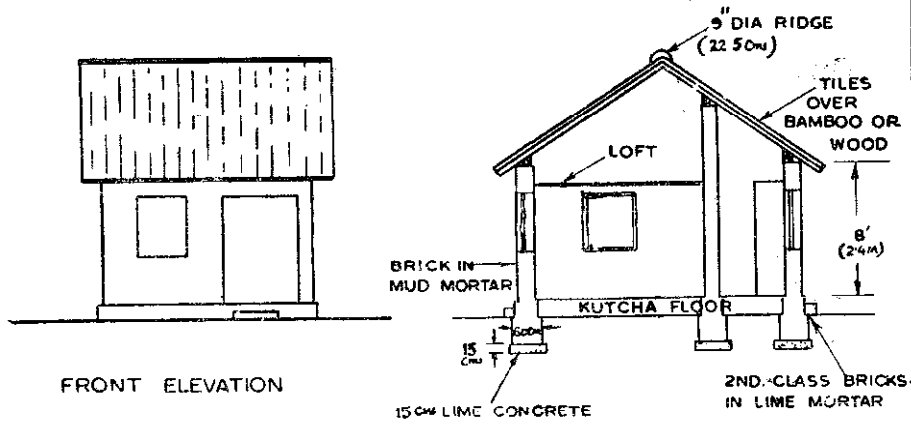

FRONT ELEVATION

SECTION AT A-A

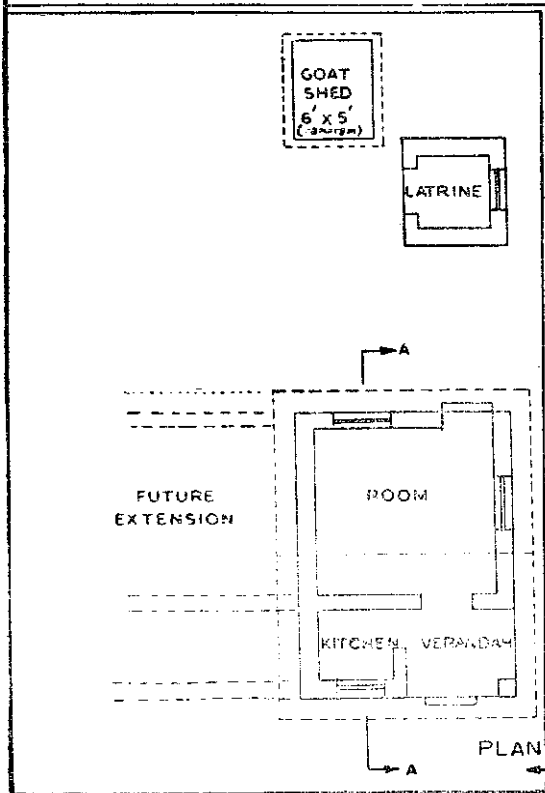

DESIGN FOR ONE ROOM HOUSE.

PLAN

GATE

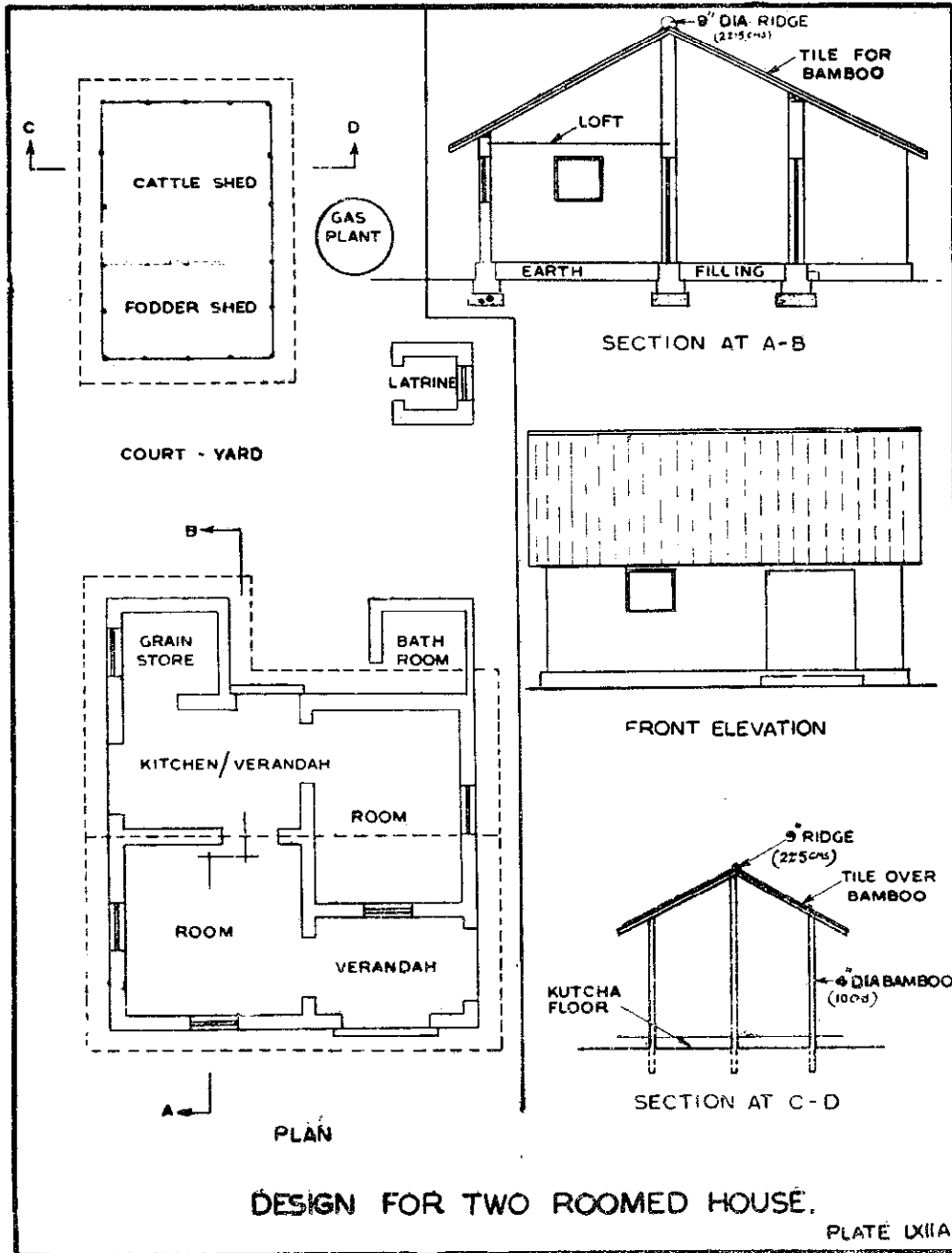

DESIGN FOR TWO ROOMED HOUSE.

PLATE LXIIA

AIR SEASONING OF TIMBER

(Figures relate to Plate LXIII)

- Contact Agency : 1. National Building Organization, New Delhi.
2. Forest Research Institute, Dehradun.

Introduction : Wet timber as obtained from trees is unstable, and splits and cracks due to shrinkages in drying. It is also an easy prey to decay by fungi, borers, termites, etc. It should not, therefore, be used for building and other structural purposes, unless dried in a controlled manner.

Simple and cheap ways of drying timber in the forest and yard are given here. Their adoption will help reduce splitting, cracks, decay and loss of timber.

Method of seasoning

(i) *Logs* : The logs after felling should be properly stacked, if not possible to transport them quickly. The barks should be removed. They should be sawn as quickly as possible and then stacked properly, the logs themselves being used as spacers. The ends of the logs or planks should be painted with sealing liquid tar or asphalt or shaded with projecting overhanging material like canvas, plywood, etc. This helps in reducing end-cracks.

(ii) *Heavy beams or sleepers* : Stacking and seasoning are easily carried out in the open under a temporary roof. The stacking should be done crossways and in a slightly slanting position to allow rain water to flow easily. Space should be allowed both above and below the stack for air circulation. All other processes are the same as in the case of logs.

(iii) *Planks* : In the case of planks, the circulation of air is the most important factor in stacking. Uniform spacers in thickness and length should be selected and they should be stacked nearly one above the other. Haphazard use of spacers may lead to cracks and warps in timber. Planks may be placed slanting against a support or against each other.

Heavy weights should be placed on the top of the stack to keep the planks straight during and after drying. Random stacking hinders the process of uniform drying.

General requirement for air seasoning

1. Ground for stacking must be clean, smooth and dry.
2. Bark and wood waste must be removed from the stack.
3. Foundation for the base can be made with the help of brick blocks spaced 40—50 cm. apart. Longitudinal members of good, seasoned timber—preferably treated—are placed in these blocks. Planks etc. can then be stacked on these members with the help of spacers, $1" \times 1\frac{1}{2}"$ blocks of well seasoned timber.
4. Spacers should be of uniform thickness, used for separating layers of planks, placed uniformly one above the other 30—60 cm. apart, sufficient in number to prevent sagging.
5. The width of the stack should normally not exceed 200 cm.
6. Timbers of the same size should be stacked together as far as possible.

7. Rotten timbers should be immediately removed from the stack.
8. There should be a free passage for air to all parts of the stack.
9. Regular inspection should be carried out to reduce decay and rotting and to prevent their further spread.

Advantages : Air seasoning is very cheap and does not require any material or chemicals. After seasoning the timber becomes lighter, stronger, more stable, more resistant to decay, easier for work, paint and polish, easier to treat with preservatives.



FIG. 1

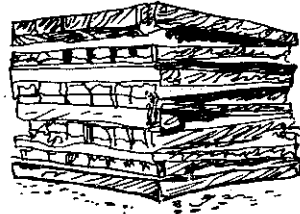

FIG. 2

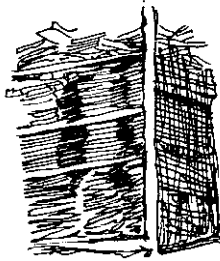

FIG. 3

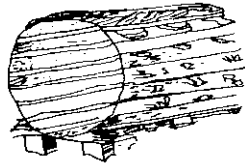

FIG. 4

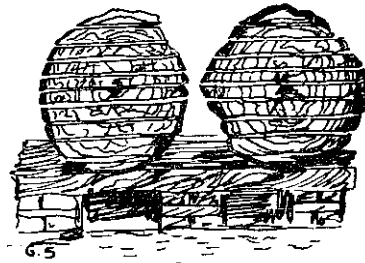

FIG. 5

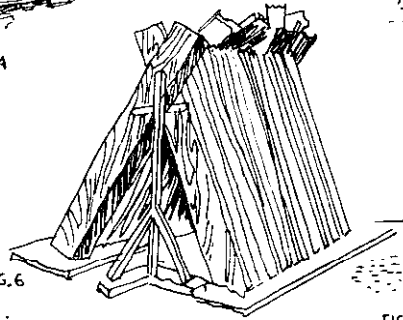

FIG. 6

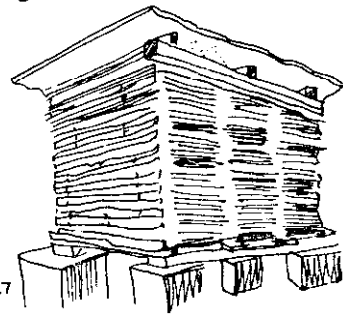

FIG. 7

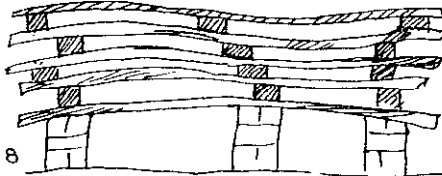

FIG. 8

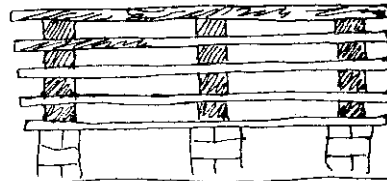

FIG. 9

AIR SEASONING OF TIMBER

GRASS AND PALMYRA THATCH FOR ROOFING

(*Figures relate to Plate LXIV*)

Contact Agency : National Buildings Organization, New Delhi.

Introduction : Large sums of money and time are spent periodically in the replacement of decayed building materials like timber, bamboo, grass thatch and palmyra leaves, etc. in order to make the houses suitable for habitation. Such organic materials are more susceptible to decay, caused by the attack of fungi and insects. Destruction by fire is caused in many places every year, particularly in the rural areas.

Preservative treatment of grasses and palmyra leaves used for roofing is very important to improve the quality of the rural houses.

The National Buildings Organisation, Delhi has developed a cheap and satisfactory method of preservative treatment against the insects and decay and also against fire. Through these treatments the expected service life of 3 years of untreated grass-thatch can be extended upto 10 to 15 years. Similarly the expected service life of untreated palmyra leaves can be extended by 5 to 10 years.

1. *Treatment against fungi and insects* (antiseptic treatment)

(a) Chemicals required

- (i) Copper sulphate (neela thotha)
- (ii) Sodium dichromate (surkh kahi)
- (iii) Acetic acid (tezab sirka)

(b) Preparation of solution

- (i) Dissolve carefully 8 kg. of copper sulphate and 8 kg. sodium dichromate (surkh kahi) in 200 litres of water (10 kerosene oil tins)
- (ii) Add 50 gms. of acetic acid (tezab sirka) in the solution.

To facilitate the dissolution of crystals, copper sulphate and sodium dichromate could be broken down to pebble size and left in water overnight. Warm water also facilitates and hastens the dissolution. Acetic acid should be handled carefully to avoid burns.

2. *Treatment against fire and decay* (Fire retardant-cum-antiseptic treatment)

(a) Chemicals required

- (i) Copper sulphate (neela thotha)
- (ii) Boric acid (boric amal)
- (iii) Zinc chloride (kupyatu nearaya)
- (iv) Sodium dichromate (surkh kahi)

(b) Preparation of solution

Dissolve 3 kg. of boric acid (boric amal), 1 kg. of copper sulphate (neela thotha), 5 kg. of zinc chloride (kupyatu nearaya) and 6 kg. of sodium dichromate (surkh kahi) one after another in 20 gallons of water (5 kerosene oil tins).

3. *Equipment* : Depending upon the quantity of grass or palmyra leaves, containers of different sizes are required for preparation of solution and for dipping the material for treatment. Since the material to be treated has to be kept dipped for several hours or sometimes for several days, it is better to have bigger containers, so that large quantities could be treated at a time, thus cutting short the period of treatment. Half-drum shown in Fig. 1 is cheap and convenient where quantity of material to be treated is not large. The drum can also be cut and the cut portion turned back, as shown in Fig. 2. It can be used on platform for drawing the solution from the material after treatment and before final removal for drying, thus minimizing wastage of solution.

Large petrol drums cut into half, can be joined together to make bigger containers as shown in Figure 3. Wooden or other blocks should be used as stands to prevent wobbling of the drum.

Concrete pits or brick pits lined with concrete as shown in Figure 4 could be used, whenever possible. But these must be cleaned very thoroughly before and after use so that in subsequent use, the materials coming into their contact are not poisoned.

4. *Treatment*

(i) The material to be treated should be left in air for some days to dry, so that moisture content of the material is around 12-15%. It helps in fixation of some of these chemicals. Material with more than 20% moisture content can be treated with difficulty and would lead to a considerable dilution of the solution.

(ii) If the material needs to be cut or shaped, it should be done before the treatment.

(iii) Thatch is usually tied with split bamboos and these should be treated along with the thatch. Bamboos should be split and cut into sizes before putting them into tanks for dipping.

(iv) The leaves or bundles of grass, loose, or loosely tied together should be dipped into the preservative solution. These should be turned over a little so that they wet well on all sides and there is no hindrance to the absorption of the preservative. It should be ensured that the grass and leaves remain totally submerged under the surface of the solution.

(v) Bamboos to be treated can be dipped along with the thatch or separately as convenient. If the bamboo lengths are more than that of the container, then they could be placed in the solution with one end sticking out as shown in Fig. 5. After the period of treatment, these should be reversed so as to treat those ends which were sticking out.

(vi) For antiseptic treatments, six-hour dipping in the solution for the grass-thatch and 24-hour dipping for palmyra leaves, are sufficient.

For fire and decay treatment, 32-hour dipping in the solution for the grass-thatch and 48-hour for palmyra leaves are found to be sufficient.

Cost

(i) The average cost of one kg. of ingredients for the control of fire and decay treatment is Rs. 5/-. It suffices for 10 kg. of grass-thatch or ten palmyra leaves. Thus it comes to 50 p. per kg. of thatch-grass or one palmyra leaf.

(ii) The average cost of one kg. of ingredients for antiseptic treatment is Rs. 4.50 which treats 30 kg. of thatch grass or 30 palmyra leaves. Thus it comes to 15 p. per kg. of thatch grass or one palmyra leaf.

(iii) Two persons can treat on an average one quintal of thatch per day.

(iv) The price of two half-drum units of 44 litres or one unit of modified cut drum is about Rs. 100 including welding charges. They last for 4-5 years.

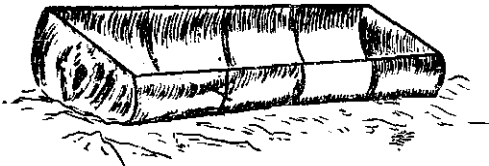

FIG. 1

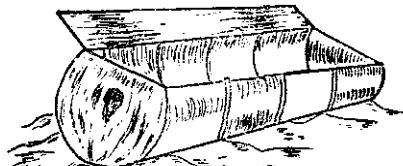
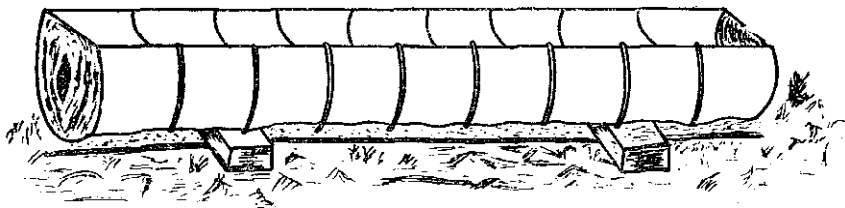

FIG. 2

CONTAINERS REQUIRED FOR THE TREATMENT OF GRASS AND PALMYRA THATCH FOR ROOFING.



METHOD OF TREATMENT

FIG. 3



FIG. 5

TREATMENT OF GRASS & PALMYRA THATCH FOR ROOFING.

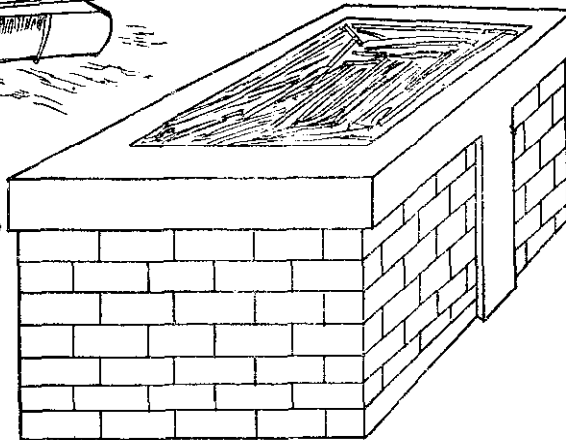

BRICK PIT FOR THE TREATMENT

FIG. 4

CINVARAM BLOCK PRESS

(Figures relate to Plates LXV to LXVA)

Contact Agency : Inter-American Housing Centre, Bogota, Colombia.

Introduction : There has always been a need for a single low cost, portable machine for making building blocks and tiles from common soil. The cinvaram machine developed by Inter-American Housing Centre in Bogota, Colombia, fulfils this requirement. It has since been used extensively in developing countries including India. The blocks and tiles made from this machine have several advantages. They are easy to make, are cheap, can be easily handled and need no baking. Transportation costs are avoided since the machine is portable and the blocks are made near the construction site.

Equipment : Cinvaram block press, shown in fig. 7 weighs 63 kg., and has a dimension of $24 \times 37 \times 64$ cm. Other particulars are as follows :

Application force of lever	36 kg.
Bearing strength of fully cured blocks	14-35 kg/cm. ²
Size of block	9 cm. \times 14 cm. \times 29 cm.
Size of tile	5 cm. \times 14 cm. \times 29 cm.
Average number of blocks or tiles made by 2 workers per day	300—500
Average number of blocks needed for a two room house	2500
Average number of blocks per 50 kg of cement	150

4 different moulds for different kinds of blocks and tiles are available.

Other equipment needed :

1 wide-mouth glass jar

6 mm. to 10 mm mesh wire screen

Box, inside dimension ($60 \times 4 \times 4$) cm.

Fine sieves

Suitable mixing boards (120×250 cm.) and (250×250 cm.)

Bottomless measuring box

Bottomed measuring box

Shovels

Sprinkling can

Mounting board ($250 \times 20 \times 5$) cm.

4 bolts 1.5 cm.dia. \times 8 cm. long

8 workers are required for one machine.

Processes : (i) *Particle determination test* : This test analyses the soil to find the ratio of sand to clay or silt.

(a) Pass the soil through a 6 mm. screen.

(b) Pour into a wide-mouth jar to fill it half.

- (c) Fill the jar with water and cover it.
- (d) Add 2 tea spoonful of salt to help the clay particles settle faster.
- (e) Shake the jar vigorously for 2 minutes.
- (f) Set the jar on a level spot.

The soil should settle in about half an hour. The sand will settle quickly at the bottom. The clay or silt particles will settle last. Measure the layers to determine the ratio of sand and clay or silt. Use the soil that is at least 1/3rd sand between 5 and 30 % clay or silt. The soil available can be made suitable by adding sand or clay.

(ii) *Compaction test* : The test indicates the packing quality of the earth, which depends on the percentage of clay in the sample.

- (a) Take a handful of dry, screened earth and moisten it until it is damp enough to form a ball when squeezed in the hand, but not so damp that it will leave more than a slight trace of water on the palm.
- (b) Drop the ball from a height of about three feet on to the hard ground. If the ball breaks into a few smaller pieces, the packing quality is good to fair. If it disintegrates the quality is poor.

(iii) *Box test* : The box test is guide to the proper soil-cement ratio. It measures the shrinkage of soil which contains no stabilizer. The box should have these inside measurements (4×4×60) cm.

- (a) Oil the inside surface of the box thoroughly.
- (b) Pack the box wall with moist soil, previously passed through 6 mm. mesh screen. The soil should be moistened to pack well, but it should not be muddy.
- (c) Tamp, especially at the corners.
- (d) Smooth off the surface with a stick.
- (e) Place the box in the sun for three days or in the shade for seven days. It should be protected from rain.
- (f) Measure the shrinkage by pushing the dried sample to one end of the box. The following table gives the cement to soil ratio to be used for different shrinkages.

<i>Shrinkage</i>	<i>Cement to soil ratio</i>
Not over 15 mm.	1 part to 18 parts
15 mm. 30 mm.	1 part to 16 parts
30 mm. 45 mm.	1 part to 14 parts
45 mm. 60 mm.	1 part to 12 parts

When lime is used instead of cement, use double the amount. Do not use the soil if it cracks or shrinks more than 60 mm.

(iv) *Making block and tiles*

- (a) Determine the number of blocks and tiles needed. 3 blocks give one sq. ft. of wall, 2 tiles give one sq. ft. of flooring.
- (b) Dig at a selected spot. Normally 15 cm.—30 cm. depth should be enough. Sandy soil with a low proportion of clay makes better blocks.
- (c) *Cement mixing* : The soil dug should be screened through 6 mm. 10 mm. wire mesh. Both cement mixing and moisture mixing

should be done thoroughly. A suitable mixing board (120×250) cm. is needed. Set a large bottomless measuring board on the mixing board. Fill it with soil and level off the top. Lift the box, leaving a measured pile of soil on the board. The soil should spread out over the mixing board as the box is lifted. Use a smaller bottomed measuring box for a measured amount of cement. The cement should be emptied evenly over the soil. After a correct proportion has been emptied, mix the cement and soil by turning it over with a shovel until it changes uniformly throughout to a different shade of colour.

- (d) *Moisture mixing* : Add water with a sprinkling can without making puddles. (Fig. 2). Mix it thoroughly again, by turning it over with a shovel, check whether the moisture is correct by squeezing a handful of mixture. If dropped on to a hard surface from shoulder height, it should break into small fragments. The mixture should be used within one hour after water has been added.
- (e) *Pressing* : Open the cover. Push the piston down. Dump the proper amount of soil-cement mixture into the box. Fill the corners of the box to the top. (Fig. 2). Press a bit in the corners with your fingers. Replace the cover. Move the lever to a vertical position. (Fig. 3). Disengage the lever latch. Move the lever to a horizontal position on the side opposite to the lower rollers. (Fig. 4). One man of average weight should be able to move the lever up and down with only two or three pushes. Do not exert extra pressure. The lever must be lowered completely. (Fig. 5). Move the lever to a vertical position, engage the lever latch and return the lever to its rest position on the lower rollers. Open the cover. Depress the lever steadily to eject the block. (Fig 6).

If the blocks are lifted from the machine and carried properly and carefully, and if the mixture is correct and the machine is in good adjustment, the blocks will not break easily. Press in on opposite ends of the block with the fingers closed, using part of the palm. (Fig. 7). To set the brick down, tip it into place on its side.

- (f) *Curing and stacking of blocks* : The blocks should be laid on flat, un-rapped, clean planks, wide enough to support the full width of the blocks. If such boards are not available, the blocks should be placed on smooth ground covered with paper or leaves so that they are not in direct contact with the earth. If the block stacks cannot be put inside a shelter, cover them with heavy paper or plastic.

After overnight drying, the blocks should still be protected from the weather, because they must still cure slowly for four or five days more. For the first four days, they should be sprinkled lightly with water twice a day. A plastic cover is useful to maintain moisture in the pile. If lime is used, double the curing time. The blocks must not be stacked solidly, there should be a space of about an inch between blocks to let them cure properly. A good stacking arrangement is three blocks side by side with an inch space between them, crossed with three blocks above alternating the direction of each layer. (Fig. 8). The blocks can be used for building after a week.

PLATE LXV

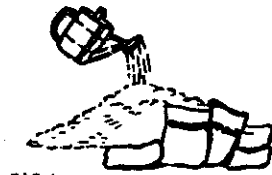

FIG. 1

Moistening
the Soil

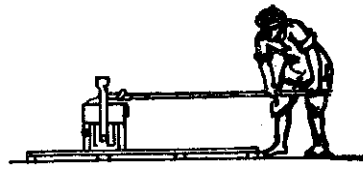

FIG. 4

Lowering the Lever.

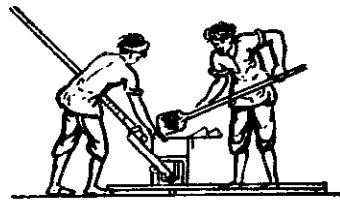

FIG. 2

Filling the Box.

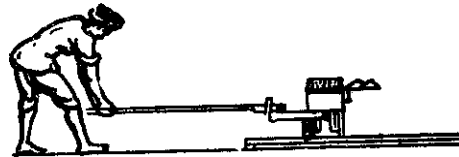

FIG. 5

Ejecting the Block

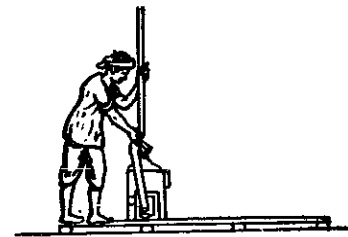

FIG. 3

Raising the Lever

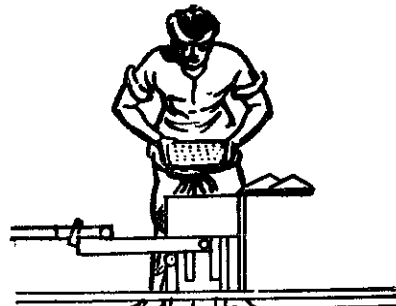
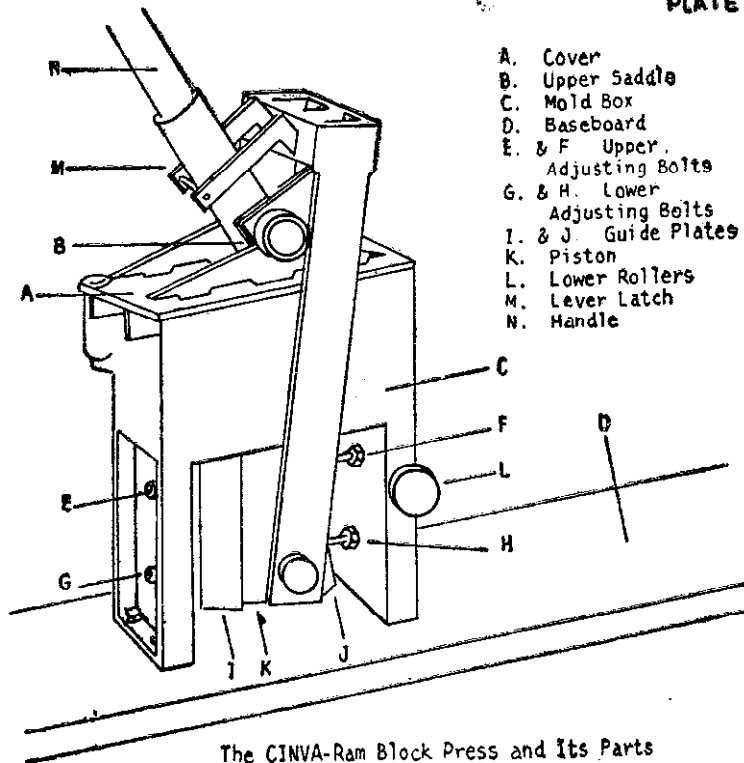

FIG. 6

Removing the Block.

PLATE LXV A



The CINVA-Ram Block Press and Its Parts

FIG. 7

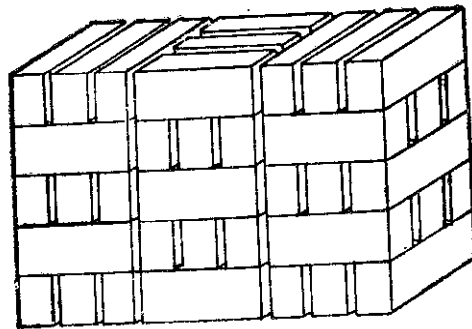

FIG. 8 Blocks stacked for 10-day cure

Who's Who in Appropriate Technology

INTRODUCTION

This is a preliminary attempt to prepare a list of individuals and institutions who are conceptually interested or practically involved in the promotion of appropriate technology. The list runs into three parts: two for individuals in India and abroad and one for international institutions. The terms 'appropriate technology' or 'intermediate technology' and several others of the same connotation are less than two decades old. However, in India, the concept has all along been a component part of the constructive movement launched by Gandhiji over half a century ago. People like Jamunalal Bajaj, Maganlal Gandhi, Kumarappa, several sarvodya workers, Ram Krishan Mission and such other organisations have been seriously interested in the work. Sri Jayaprakash Narayan and Acharya Vinoba Bhave provided leadership for the movement after Gandhiji died. It is for this reason that, there are at present thousands of workers in India at every level who are concerned with one or other aspect of appropriate technology directly or indirectly.

Sophisticated western technology and the spell of automation and energy-intensive and capital-intensive resources, however, continued to remain a major obsession with the world including the Indian intellectuals and ruling elite until the pioneering efforts of Dr. E. F. Schumacher. Schumacher's studies and writings made many thoughtful people realise the impossibility of achieving the goal of an affluent society for the whole world with the existing material and energy resources which are by their nature limited and non-renewable. He started a movement of intermediate technology in the world which concerned itself with simple living, preservation of ecology, environment and the living nature around us. Terms and phrases like 'environment,' 'ecology,' 'pollution,' 'habitat,' 'limits to growth,' etc. have suddenly assumed great importance all over the world stimulating action by groups as well as by individuals. Thinkers like Ivan Illich, Barbara Ward, Barry Commoner and others have enriched the concept and produced systematic literature on the subject. Institutions like Intermediate Technology Development Group and its network all over the world, Brace Research Institute, Canada, the 'Whole Earth Catalogue' 'Ecology Action,' 'the New Alchemy Institute,' 'VITA,' 'Movement for a New Society' etc. have taken up practical projects. Even before these concepts acquired currency in the western world, there were devoted workers, church missionaries and other groups, who had been working in the name of God, religion or humanity for the weaker communities, rural areas, tribal and inaccessible areas in Africa, Asia and Latin America and used the methods of intermediate and appropriate technology.

To collect the material for this list was by no means an easy task. Efforts to gather information through letters and questionnaires did not succeed in many cases. There are in the field quite a number of exponents and practitioners of appropriate technology information about whom we failed to collect. But we are keen to make it more comprehensive and will welcome information and suggestions. Now that this initial effort has acquired a shape it may be made more useful by adding new names in other editions.

Several of the members of the executive committee of the Appropriate Technology Development Association (ATDA) have done commendable work in appropriate technology. Their names are not repeated in the list to avoid duplication. These can be found in the list of the members of the executive committee already given on the back cover of this volume.

INDIA

- ACHWAL, PROF. M. B.—*Architect.*
Director; Housing, Education and Action Research and Training (HEART).
Harihar Bhawan, Shiya Bang Palace Rd., Baroda.
- AGARWAL, ANIL—*Journalist*
Indian Express, Bahadur Shah Zafar Marg,
New Delhi.
- AHMAD, JAVED—*Research and rural development.*
Front for Rapid Economic Development (FREA),
10, 7/27 Grants Building, Arthur Bunder Road,
Colaba, Bombay.
- ALEXANDER, RAJAN—*Drilling rigs and water supply.*
Water Development Society, C-2 and C-5, Indl. Estate,
Moula Ali, Hyderabad 500 040.
- BAKER, LAWRIE—*House design and architecture.*
Architect, Trivandrum.
- BALARAM, S.—*Design*
Associate Chairman, Faculty of Product Design, Na-
tional Institute of Designs, Paldi, Ahmedabad.
- BALASUNDARAM, S.—*Spinning.*
Textool, Coimbatore.
- BANERJI, JOHN A. K.—*Rural Development.*
Church's Auxiliary for Special Action (CASA).
MCA, Massey Hall, Jai Singh Road, New Delhi--
110 001.
- BENRIA, MUKTESHWAR—*Integrated Rural Develop-
ment.*
Gopalwadi Agricultural Training Centre, P. O.
Antamada, Via. Rayaguda, Koraput.
- BEHARI, BIPIN—*Documentation.*
Appropriate Technology Cell, Ministry of Industrial
Development, Udyog Bhawan, New Delhi 110 001.
- BHAI, PARAS—*Integrated Rural Development.*
Sram Bharti, P. O. Khadigram, Moughyr.
- BHAI, PREM—*Integrated Rural Development.*
Agrindus Institute, P. O. Banwasi Seva Ashram,
Govindpur, Mirzapur.
- BHAI, VIKAS—*Research and Rural Development.*
Youth Organiser, Sarva Seva Sangh, Varanasi
221 001.
- BHAT, V. G.—*Carpentry, blacksmithy and aluminium work*
2-31 Central Govt. Employees Coop. Housing Society,
Four Bungalow Road Andheri (West) Bombay 400 058
- CHAKRABORTY, S. S.—*Training.*
Principal; Gram Sewak Training Centre, R. K.
Mission, Narendrapur, Calcutta.
- CHOUDHRI, MANMOHAN—*Integrated Rural Develop-
ment.*
Utkal Sarvodaya Mandal, Theriashahi, Cuttack.
- D' COSTA, E. P. W.—*Consultant.*
Managing Director, I.I.P.O., 2-A, National Insur-
ance Bldg. Parliament Street, Post Box No. 288,
New Delhi 110 001.
- DASGUPTA, SATISH CHANDRA—*Rural Scientist and
Technologist.*
Bankura, West Bengal.
- DAS, R. C.—*Integrated Rural Development.*
Assam Seva Samiti, Gauhati 16.
- DAS, Dr. S. R.—*Microbiology of Biogas.*
Central Drug Research Institute, Lucknow.
- DATE, Dr. A. W.—*Research.*
Department of Mechanical Engineering, I.I.T., Pawai,
Bombay.
- DEODIKAR, Dr. G. B.—*Beekeeping.*
Ranade Blocks, Ganesh Khind Road, Pune-5.
- DESAI, MANI BHAI—*Animal Husbandry.*
Bhartiya Agro-Industries, Uruli Kanchan Farm,
Pune.
- DEVDasAN, Dr.—*Nutrition and food technology.*
University of Coimbatore, Coimbatore, Tamil Nadu.
- DUBEY, NARENDRA—*General.*
Joint Secretary, Sarva Seva Sangh, 46, Palsikar
Colony, Indore-4.
- DUNN, Lt.-Gen. O. P.—*Agriculture and Water.*
Executive Director; Action for Food Production
C-43, N. D. South Exten.-II, New Delhi-110 049.
- DUTTA, Dr. R. L.—*Solar Energy.*
Chemical Research Institute, Central Salt and Marine
Research Institute, Bhavnagar, Gujarat.
- DUTT, SOM—*Village Industries.*
Khadi Ashram, Panipat.
- FINNEY, JOHN—*Education.*
Executive Secretary; Technical Education Commis-
sion of the Methodist Church in South Asia, 17,
Boulevard Road, Delhi-110 006.
- FUTEHALLY, ZAFAR—*Expert on Environment and
Ecology.*
Wild Life Fund, Post Dodda Gubi Via Vijaynagar,
Bangalore-34.
- FRANCIS, JULIAN, —*Integrated Rural Development.*
OXFAM, D-238, Defence Colony, New Delhi-110 024.
- GARG, Dr. H. P.—*Solar Energy.*
Central Arid Zone Research Institute, Jodhpur.
- GHOSH, M. K.—*Solar Cooker.*
220, Outer Circle Road, Jamshedpur-1.
- GUJAR, Dr. T. S.—*Health Community, Irrigation.*
Maharashtra Arogya Mandal, Hadapsar, Pune.
- GUPTA, Dr. CHAMAN LAL—*Environment and solar
energy.*
Centre for Environmental Studies, Pondicherry-2.
- GUPTA, KRISHNA MURTI—*Hill Development.*
Executive Secretary, Himalaya Seva Sangh, Rajghat,
New Delhi-110 002.
- HEMPHILL, Mrs. MARGARET—*Education.*
International Educational Development Inc., North 75,
Panch Shila Park, New Delhi-110 017.
- JITTA VIRAH, SADHU—*Integrated Rural Development.*
Jeevjayothi Bramallor, P. O. Via—Kotharuangalam-
686691.
- JYENGAR, Dr. M. S.—*Designer and Consultant.*
DII/NPL Quarters, Dr. Krishna Road, New Delhi-
110 020.

- IYER, K. V.—*Consultancy*.
Esskem Enterprise, Nirmal, Nariman Point, Bombay.
- JACOB, B.—*Rural Development*.
Research and Analysis Officer; CARITAS-India,
CBCI Centre, Ashok Palace, New Delhi-110 001.
- JALALUDDIN, Prof.—*Research*.
Z. H. College of Engg. and Technology, A.M.U.,
Aligarh.
- JAYARAJAN, P.—*Fertilizers*.
Food Marketing Centre, St. Xavier Institute,
Jamshedpur.
- JENA, B. C.—*Youth Action*.
Sarvodaya Samiti, Koraput.
- JUYAL, B. N.—*Growth centres and rural development*.
Gandhian Institute of Studies, Rajghat, Varanasi.
- KAPOOR, R. N.—*Training and Research*.
Principal, Allahabad Polytechnic, Allahabad.
- KAPOOR, SUDARSHAN—*Ring Well, Sanitary Latrines
and Education*.
Friends Rural Centre, Rasulia, M. P.
- KAPOOR, Dr.—*Paddy Husk Research*.
Department of Material Science, I.I.T., Kanpur.
- KHAN, M. RAFIQ—*Editor, 'Interdiscipline' Quarterly
which carries a section on appropriate
technology*.
Gandhian Institute of Studies, Rajghat, Varanasi.
- KRISHNAMOORTHY, Dr. Ch.—*Dryland agriculture*.
Adviser cum Project Director; All India Coordinated
Research Project for Dryland Agriculture, Hydrabad.
- KRISHNASWAMY, N.—*Youth Action*.
Director; Voluntary Action Cell, 221, Deen Dayal
Upadhaya Marg, New Delhi-110 001.
- KRISHNARAO, G. F.—*Social Work*.
Head; Department of Social Work, Visva Bharti,
Sri Niketan, W. B.
- MAKHJANI, ARJUN—*Integrated Rural Development*.
Foundation for Research in Community Health, Dhokavde,
P. O. Awas, Distt. Kulaba, Maharashtra.
- MARATHE, P. G.—*Wind Mills, Toddy Tapping equipment*.
Assorted Industrial Machines & Products
31, Kumbhos Industrial Estate, Bhandup, Bombay.
- MASHRUWALA, PRAVIN—*Social Work*.
Lok Bharthi, Sanosara, Bhavnagar.
- MAZUMDAR, B.—*Cottage Leather*.
Block No. 7, 7 Rly. Housing Society, Irla, Bombay
400 056.
- MATTHEWS, Dr. (Miss), C. M. E.—*Health and
Medicine*.
Community Health Department, Christian Medical
College, Vellore-2.
- MINHAS, Dr. B. S.—*Economist and Planner*.
Indian Statistical Institute, 7, S. J. S. Sansanwal
Marg, New Delhi-110 029.
- MODDIE, A. D.—*Hill Area Development and Environment*.
W-13, Greater Kailash I, New Delhi.
- MOHSIN, Dr. M. A.—*Dryland Agriculture*.
Soil Physicist, Agricultural Research Institute, Kanke,
Ranchi.
- MUKERJI, NABA KUMAR—*Animal Husbandry and
Dairy*.
P. O. Sri Niketan, Visva Bharti, W. B.
- MUKHERJI, SUBRATA—*Training*.
74, Purva Das Road, First Floor, Calcutta- 700 020.
- NAG, T. K.—*Cottage match*.
C/S, Vibha Bldg., 31 Ramchandra Lane (Malad
West), Bombay 400 064.
- NARAYAN, JAYAPRAKASH—*Foremost thinker, philo-
sopher and guide of appropriate
technology movement
in India*.
Kadam Kuan, Patna-4.
- NAYUDDAMA, Dr. S.—*Research with specialisation in
leather technology*.
Director General, C.S.I.R., Rafi Marg, New Delhi-
110 001.
- PADMANABHAM, V.—*Khadi and village industries*.
Gandhigram, Madurai, Tamil Nadu.
- PANDIYA, ARVIND—*Solar equipment and research*.
Khadi Prayog Samiti, Ahmedabad.
- PANT, Dr. D. D.—*Research and Education*.
Vice-Chancellor, Kumaon University, Naini Tal.
- PURSHUTAM LAL—*Rice milling machinery*.
Kisan Krishi Yantra Udyog, 64 Moti Bhawan,
Collectorganj, Kanpur, 208 001.
- PARIKH, MOHAN—*Research and Development*.
Director; Agro Tools Research Centre, Suruchi, Vasahat,
Bardoli, Gujarat.
- PASHRICHA, Dr. M. S.—*Research*.
Department of Mechanical Engineering, I.I.T., B.H.U.,
Varanasi-221 005.
- PATEL, J. J.—*Biogas*.
Sai Darshan Apts, Block No. 3, S. V. Road, Santacruz
(West), Bombay 400 054.
- PATEL, JAWAHAR LAL—*Recycling of waste*.
Patel Poultry Farm, Baroda.
- PATEL, J. S.—*Agriculture*.
Agricultural Institute, P. O. Kosbad Hill, Distt. Thana,
Maharashtra.
- PAUL, Dr., T. M.—*Biogas and Recycling of waste*.
Western National Dairy Research Institute, Aarey Milk
Colony, Bombay.
- PLANNING RESEARCH AND ACTION DIVISION
—*Action Research*.
State Planning Institute, Kalakankar House,
Lucknow, U. P.
- PRAKASH, Dr. BHARTENDU—*Science education and
paddy husk*.
Vigyan Shiksha Kendra, Attara, Banda, U. P.
- PRASAD, Dr. BALBHADRA—*Research*.
44, Patliputra Colony, Patna, Bihar.
- RAHMAN, Prof. A.—*Science policy*.
Council of Scientific and Industrial Research, Rafi
Marg, New Delhi-110 001.
- RAJASEKHARAN, M. V.—*Rural development*.
Asian Institute for Rural Development, 19, Kanakpura
Road, Basavanagudi, Bangalore-560 004.
- RAMP, RUDY—*Food and Nutrition*.
CARE Inc., B-28, Greater Kailash, New Delhi-48.

- RANADE, Smt. SOBHANA—*Women and social welfare.*
Pranidhi, Kasturba Trust, "Neelachal", Baner Road,
Aundh, Pune.
- RAO, U. SHANKAR—*Inland water transport.*
Indian Centre of Maritime Economics, Hooghly Point,
102/6, Erondvana, Pune.
- REDDY, Prof. A. K. N.—*Research.*
ASTRA, Institute of Science, Bangalore.
- RUDRAMOORTHY, B.—*Rural development.*
Adviser (Rural Development) Mafatal Services (P)
Ltd., Mafatal Centre, Nariman Point, Bombay-1.
- ROY, SANJIT—*Integrated rural development.*
Director; Social Work and Research Centre, Tilonia
305 812, Ajmer, Rajasthan.
- RURAL FABRIC CENTRE—*Spinning and weaving.*
Permacullur, Tirupura, Tamil Nadu.
- SABNIS, S. R.—*Poultry.*
Rural Agricultural Institute, Narayangaon, Pune,
Maharashtra.
- SALUJA, Dr. S. S.—*Research.*
Director; I. T., B.H.U., Varanasi-221 001.
- SADGOPAL, ANANDA—*Integrated rural development and
science education.*
Kishore Bharti, M. P.
- SANJIVI, Dr. K. S.—*Rural Health.*
Professor Emeritus in Medicine "Shantam", Perguli
P. O., Madras—600 096.
- SANTIAGO, S.—*Integrated rural development.*
Director; Indo-German Social Service Society, C-42,
South Extension Part II, New Delhi-49.
- SARAN, TRIPURARI.—*Integrated rural development.*
Sarvodaya Ashram, P. O. Sokhodeora, Distt. Nawada,
Bihar.
- SEN, KSHIRODE—*Integrated rural development.*
Sanchalak; Gandhi Gram Vikas Samiti, Joynagar,
P. O. Agartala, Tripura.
- SEN, Dr., P. K.—*Integral rural development and education.*
Seva-Bharati, Rappati, Distt. Midnapur, W. Bengal.
- SESHADRI, Dr., C. V.—*Research on chemical engineering.*
Adviser and Consultant; Shri A. M. M. Murugappa
Chettian Research Centre, 11/12, North Beach Road,
Madras—600 001.
- SETHI, RAJIV.—*Communication.*
4, Shankar Market, Connaught Place, New Delhi-
110 001.
- SETH D. S.—*Decentralised sources of energy*
Chairman; Tata Energy Research Institute, Bombay
House, Homi Mody Street, Bombay 400 023.
- SHARMA, ASHOK—*Agricultural research.*
Kamla Nehru Institute of Science and Technology,
Sultanpur, U.P.
- SHARMA, Dr., T. N.—*Pottery and Ceramics.*
484, College Road, Khurja, U. P.
- SIDDHU, G. S.—*Small scale paper and other industrial research.*
Director, Regional Research Laboratory, Hyderabad.
- SINGH, MUKAT—*Education and training.*
Director; Amarpurkashi Village Project, Via. Bilari,
Moradabad.
- SINGH, RAM BUX—*Biogas.*
Gobar Gas Experimental Station, Ajitmal, Etawah,
U.P.
- SAHASTRABUDHE, ANNA SAHEB—*Village industries.*
Sewagram, Wardha, Maharashtra.
- SIET INSTITUTE—*Documentation.*
Yusufgoda, Hyderabad.
- SINGH, GEETA PRASAD—*Rural Industries.*
Rural Industries Project, Manpur, Gaya.
- THAKAR, C. V.—*Bee-keeping, forest based industries.*
67/1306, AzadNagar, Veera Desai Rd. Andheri (West),
Bombay 400 058.
- THOMAS, Dr. A. M.—*Village Industries.*
Chairman, Khadi and Village Industries Commission,
Irla Road, Bombay-56.
- TAMIL NADU SARVODAYA SANGH—*Village
industries.*
Tirupur, Tamil Nadu.
- TAYYABJI, ROBERT—*Communication, Wind Mills,
handpumps*
U.N.I.C.E.F., 9 Jorbagh, New Delhi.
- VEPA, RAM. K.—*Economist.*
Vigyan Bhawan, New Delhi.
- VERGHESE, B. G.—*Editor*
Commerce Weekly, Scindia House, New Delhi-
110001.
- WELANKAR, W. A.—*Fibre, cane, bamboo and hand-made
paper.*
30, Parijat, Vishnunagar, Dombivli (West), Distt.
Thana, Bombay.
- WINDEY, Prof. M. A.—*Integrated Rural Development.*
Director; Village Reconstruction Organisation Brod-
ipet, 6/9 Guntur-52002 A.P.

WORLD

(INDIVIDUALS)

- ABRAHAM, MENA—*Architecture.*
590 Warrington Crescent, London W9 1EH, U. K.
- ACORN, MEAN—*Small scale technology.*
Governors State University, Park Forest South, Il.
60466, U.S.A.
- ADRIKO, Dr. E. T. S.—*Small scale technology.*
Faculty of Technology, Makerere University, P. O.
Box 7062, Kampala, Uganda.
- AGBLE, Dr. W. K.—*Agriculture.*
Director; Crops and Research Institute, Council for
Scientific and Industrial Research, Kumasi, Ghana.
- AHMAD, Dr. HABIBUDDIN—*Research.*
Enfield Polytechnic, Enfield, Middx, U. K.
- AKINRELE, I. A.—*Industrial research.*
Federal Institute of Industrial Research, Private Mail
Bag 1023, Ikeja Airport, Lagos State, Nigeria.
- ALBA, M.—*Rural technology.*
Director; Technology and Development Institute,
East-West Centre, Hawaii 96822, U. S. A.
- ALWARD, RON—*Solar and Wind energy, desalination.*
Brace Research Institute, MacDonald College of
McGill University, Ste. Anne de Bellevue, Quebec,
Canada.

- AMOAHI, J. K.—*Village Industries*.
Faculty of Art, University of Science and Technology (UST), Kumasi, Ghana.
- AMPRAWUM, D. B.—*Agriculture*.
Faculty of Agriculture, University of Ghana, Legon, Ghana.
- APPELE, GEORGE N.—*Anthropology*.
Philips, Maine 04966, U. S. A.
- ARRETEAU, PHILLIPE—*Rural Development*.
Pazanam 07230, Lablachere, France.
- ARIYARATNE, A. T.—*Integrated rural development and Sarodaya, known as Sri Lanka Gandhi*.
Meth Madura, No. 77, De Soysa Road, Moratuwa, Sri Lanka.
- BAKER, Dr., RANDALL—*Economics*.
Overseas Development Group, University of East-Anglia, Norwich, NOR 88C, Norfolk, United Kingdom.
- BANJO, Dr. A.—*Rural technology*.
Head, Science and Technology Section, United Nations Economic Commission For Africa (ECA), P. O. Box 3005, Addis Ababa, Ethiopia.
- BECH, J.—*Housing*.
Department of Housing and Planning Research Faculty of Architecture, University of Science and Technology (UST), Kumasi, Ghana.
- BECKEL, J.—*Technology research*.
Research Institute for International Techno-Economic Cooperation, Technical University, Aachen, Theatinerstrasse-88, D 5100 Aachen, West Germany.
- BERKOH, A. K. N.—*Village industry*.
Department of Industrial Art, College of Art, University of Science and Technology (UST), Kumasi, Ghana.
- BHALLA, A. S.—*Economics*.
Project Manager, World Employment Programme, (Technology), I.L.O., Geneva, Switzerland.
- BHATT, VIKRAM.—*Sanitary latrines, and house building*.
Housing Research, 3707, Jeanne Mance, Montreal, Canada.
- BIGG, Dr., GORDON, W.—*Boat building*.
1105 Normandy Crescent, Ottawa, Ontario, Canada, KZE, 5A3
- BOREL, P.—*Energy and transport problem*.
63 Troisième Avenue, 66269 Lomeralaye, France.
- BORTEI-DOKU, E.—*Housing*.
Faculty of Architecture, University of Ghana, Legon, Ghana.
- BOULTER, S.—*Environment*.
Society for Environmental Improvement, Clyders, Upper Farrington, Nr. Atton, Hampshire, United Kingdom.
- BRACHI, P.—*Biotechnic research and development*.
23, Gisborne Green, Derby DE1 3NA, England.
- BRONCHKORST, B. VAN—*Research*.
Technische Hogeschool, Eindhoven, Netherlands.
- BRUNET, ERIC—*Small-scale agricultural equipment*.
Brace Research Institute, MacDonald College of McGill University, Ste. Anne de Bellevue, Quebec, Canada.
- BUTLER, R. G. J.—*Research*.
Senior Research Officer, Institute of Standards and Industrial Research, Council for Scientific and Industrial Research, P. O. Box M 32, Accra, Ghana.
- CARR, M.—*Farm machinery*.
I. D. S. Sussex, 1211 La Lignon, Geneva, Switzerland.
- CARRUTHERS, I.—*Water supply, wind power*.
Wye College, Ashford, Kent, United Kingdom.
- CHAN, GEORGE L.—*Methane, village industry, nutrition, water supply*.
South Pacific Commission, P. O. Box D-5, Noumea Cadex, New Caledonia.
- CHARLES, REV. S.—*Technology*.
Salford University, St. Barnabas Vicarage, Fredrick Road, Salford, United Kingdom.
- CHOA, SWEE LIN—*Technology*.
University Pertanian Malaysia, P. O. Box 203, Sungei Besi, Selangor, West Malaysia.
- CHRISTIANS, Prof. L.—*Housing*.
Head, Department of Architecture, University of Science and Technology, (UST), Kumasi, Ghana.
- CUIUFFOLI, M.—*Training*.
ASIP, via Federico Cesi 30, 00193, Rome, Italy.
- CLARK, Dr., N. G.—*Economics*.
Department of International Economic Studies, University of Glasgow, Glasgow, Scotland.
- CLARKE, A. B. M.—*Ecology*.
Wye College, 73 Sunderland Street, Tickhill, Doncaster, Yorks, United Kingdom.
- CLARKE, ROBIN—*Soft technologies*.
8 Lambert Street, London, England.
- CLAYTON, Dr., E.—*Agricultural mechanization*.
Wye College, Ashford, Kent, United Kingdom.
- COKE, Prof., S.—*Economics*.
Department of Economics, University of Edinburgh, Edinburgh, EH8 9 JY, United Kingdom.
- COLLOMBON, J. M.—*Rural development*.
Group de recherche sur les technologies appropriées 54 rue de Varenne 75007, Paris, France.
- CONGDON, R. J.—*Appropriate Technology educational materials*.
Technische Hogeschool, Eindhoven, Postbus 513, Eindhoven, Netherlands.
- COOK, JOHN—*Medicine*.
University of Edinburgh, 25 Murrayfield Avenue, Edinburgh EH12 6AN, United Kingdom.
- COWARD, L. D. G.—*Food processing*.
Tropical Products Institute, Culham, Nr Abingdon, Berks, U. K.
- COXWORTH, E.—*Leather tanning, small-scale technologies*.
Associate Research Officer, Chemistry Division, Saskatchewan Research Council, 30 Campus Drive, Saskatoon, Saskatchewan, S7N 0X1, Canada.
- CRAWFORD, D. G.—*Housing*.
Building Design Partnership, 74 Regina Road, Finbury Park, London N4 3PP, United Kingdom.
- CRISP, MICHAEL—*Communication of appropriate technology in developing countries*.
Norrby Gard, 17011 Drottningholm, Sweden.

- DAMMINYAMA, B.—*Indigenous housing*.
Dean of Faculty (Civil Eng), Mongolian State University, Mongolia.
- DEDJIER, S.—*Science Policy*.
Research Policy Program, University of Lund, Solvegatan 8, S-22362 Lund, Sweden.
- DE GAFF-JOHNSON, Dr., J. W. S.—*Housing and road building*.
Building and Road Research Institute, University of Science and Technology, P. O. Box 40, Kumasi, Ghana.
- DE SILVA, N. N.—*Rural technology*.
Research Development Division, Co-operative Wholesale Establishment, 21 Vauxale Street, Colombo 2, Sri Lanka.
- DE WILDE, TON—*A. T. research*.
T. O. O. L... c/o Technische Hogeschool, Eindhoven, Postbus 513, Eindhoven, Netherlands.
- DICKINSON, H.—*Ferro-cement boat building, A. T. systems*.
School of Engineering Science, University of Edinburgh, Kings Building, Mayfield Road, Edinburgh EH 93 JL, United Kingdom.
- DICKSON, DAVID—*Author*.
10 Charlott Square, London, N.W.1, United Kingdom.
- DUNN, Prof., P. D.—*Power supplies, Humphrey Pump*.
APS Department, Reading University, Whiteknights, Reading, United Kingdom.
- EAVES, S. W.—*Hospital equipment*.
Project Officer, Intermediate Technology Workshops, P. O. Box 401, Zaria, N.C State, Nigeria.
- ECKEL, G. H.—*Small-scale industries*.
Ministry of Industries, P. O. Box M 39, Accra, Ghana.
- ELLIS, WILLIAM, N.—*Appropriate and alternative technologies*.
TRANET, 7410 Vernon Drive, Alexandria, Va. 22306, U. S. A.
- EL SAYED, Prof. Y. M.—*Engineering*.
Dept. c. Mechanical Engineering, P. O. Box 1098, Tripoli, Libya.
- ERIKSON, BJORN—*Appropriate Technology, research*.
Dept. of Theoretical Physics, Chalmers Technical High School, Gothenburg, Sweden.
- FARGEAS, DANIEL—*Editor*.
Fiches Ecologiques, Vingrau, 66600 Riversaltes, France.
- FERRY, JIM—*Rural development*.
P. O. Box 121, Chester Hill 2162, NS Wales, Sydney, Australia.
- FLORIDA, NIGEL—*Methane gas*.
Canadian University Service Overseas 151 Slater St., Ottawa, Ontario K1P 5H5, Canada.
- FRASER, Dr. A.—*Forestry*.
International Forest Science Consultancy, 21 Biggar Road, Silverburn, EH26 9LQ, Midlothian, United Kingdom.
- GATERE, N. M.—*Rural Industries*.
Ministry of Commerce and Industry, P. O. Box 30430, Nairobi, Kenya.
- GHADIALLY, JAL—*Small scale industry*.
Canadian Hunger Foundation, 75 Sparks Street, Ottawa, Ontario, K1P, 5A5, Canada.
- GIRARDIER, J. P.—*Solar pump*.
Président Directeur General; SOFRETES, B. P. 163, 45203 Montargis, France.
- GLAUSER, J. T.—*Wind power, wood treatment, small machinery*.
Universidad de Los Andes, Calle 18, A Carrera 1E, Apartado Aereo 4976, Bogotá, Colombia.
- GOULET, DENNIS—*Sociology and development*.
Centre for the Study of Development and Social Change, 1430, Massachusetts Ave. (Harvard Square), Cambridge, Massachusetts, USA 02138.
- GREEN, Dr. D.—*Agriculture and economics*.
University College of Wales, Aberystwyth, Department of Agricultural Economics, Pengalais, Aberystwyth, United Kingdom SY23 3DD.
- GRELIN, A.—*Agricultural tools*.
73 Arbin par Montemelian, Lyon, France.
- GYIRO-AYORO, B. I.—*Rural industries*.
Kenya Industrial Estates, P. O. Box 18282, Nairobi, Kenya.
- HAMAAMBA, A.—*Rural industries*.
Ministry of Rural Development, Natural Resources Development College, P. O. Box Ch. 99, Lusaka, Zambia.
- HAMMERSLEY, G.—*Economics*.
Department of History, University of Edinburgh, William Robertson Building, Edinburgh EH8 9JY, United Kingdom.
- HARPER, PETER—*Author*.
C/o Gambles, 40 Lexham Garden, London W8 5JR, United Kingdom.
- HARRISON, Dr., P. I.—*Education*.
42 Petters Road, Ashstead, Surrey K121 1NE, United Kingdom.
- HAIRT, D.—*Science policy*.
Science Studies Unit, University of Edinburgh, 34 Buccleuch Place, Edinburgh EH8 9JT, United Kingdom.
- HODA, M. S.—*Rural development*.
Secretary, India Development Group, 12 Watermead Lane, Carsharilton, Surrey, U. K.
- HUNT, Prof., G. J. J.—*Building and housing*.
Acting Head, Department of Building Technology, Faculty of Architecture, University of Science and Technology (UST), Kumasi, Ghana.
- HVELPLUND, F. H.—*Social anthropology and Economics*.
Brund 7700
Thisted
Denmark
- IGNACIO, R. S.—*Technology adaptation*.
Dean College of Engineering, Mindano State University, Marawi City, Philippines.
- INGLIS, M.—*Nutrition*.
Aberdeen College of Education, 44 Mid Stocket Road, Aberdeen, United Kingdom.
- JACKSON, T. H.—*Agriculture and dehydration*.
F. A. O. Horticulturist, Institute of Agricultural Research, P. O. Box 103, Nazareth, Ethiopia.

- KAPLINSKY, MR.—*Economics*.
Institute of Development Studies, University of
Sussex, Brighton, United Kingdom.
- KARUMUNA, T.—*Rural development*.
United Nations Economic Commission for Africa
(ECA), P. O. Box 3005, Addis Ababa, Ethiopia.
- KHAMMO, A. L.—*Research*.
Leeds University, 4 Norwood Grove, Leeds LS6 1DT,
United Kingdom.
- KHAN, A. U.—*Agricultural implements*.
International Rice Research Institute, P. O. Box 583,
Los Banos, Manila, Philippines.
- KIBBLEWHITE, M.—*Building construction*.
Portsmouth Polytechnic, The Long House, Owslebury,
Nr Winchester, Hants, United Kingdom.
- KIBRIA, GHULAM—*Technology development*.
Appropriate Technology Cell, Ministry of Finance,
Planning and Economic Affairs, Planning and Devel-
opment Division, 17-B, Satellite Town, Rawalpindi,
Pakistan.
- KING, Dr., K. J.—*Rural technology*.
Centre of African Studies, University of Edinburgh,
Adam Ferguson Building, Edinburgh, EH8 9LL, U.K.
- KRISTENSEN, HANS—*Rural technology*.
Institute for Development Research, 104 Vesten Vold-
gade, DK-1SS2, Copenhagen V., Denmark.
- KUBY, T.—*Political Science and design*.
Bremen University, 28 Bremen 1, Vor dem Steintor
102, West Germany.
- KURIAN, P.—*Rural technology*.
C/o INODEP, 32-34, Avenue Reille, Paris 14, France.
- LAMONT, V.—*Communications*.
64 West Street, South Pethentan, Somerset, United
Kingdom.
- LANGDON, S. R. W.—*Economics of A. T.*
University of Sussex, Balneath Manor West, S. Char-
ley, Nr. Lewes, Sussex, United Kingdom.
- LARA-HARRISON, F. A.—*Engineering*.
Universidad Centro-americana Jose Simeon Canas,
San Salvador, El Salvador.
- LAVOIE, MONIQUE—*Policy planning*.
Policy Analysis Branch, Canadian International Devel-
opment Agency, 122 Bank Street, Ottawa, Ontario,
K1A 0G4, Canada.
- LAWAND, T. A.—*Solar, wind energy and desalination*.
Brace Research Institute, MacDonald College of
McGill University, Ste. Anne de Bellevue, Quebec,
Canada.
- LERCH, H. D.—*Rural development*.
Research Institute for International Techno-Economic
Co-operation, Technical University, Aachen, Thea-
tinerstrasse 88, D 5100 Aachen, West Germany.
- LEWIS, R. T.—*Agricultural machinery*.
National College of Agricultural Engineering, Silsbee,
Bedford, U. K.
- LIVINGSTON, I.—*Development Planning*.
Economics Department, Newcastle University, New-
castle Upon Tyne, U. K.
- LOBO-GUERRERO, J.—*Wind power, wood treatment,
small machinery*.
Universidad de los Andes, Calle 18 A Carrera 1E,
Apartado Aereo 4976, Bogota, Colombia.
- LORRAINE, Dr. J. A.—*Population control*.
Department of Social Medicine, University of Edin-
burgh, Usher Institute, Edinburgh, EH9 1DW, U. K.
- MACKILLOP, ANDREW—*A. T. equipment*.
275 Kings Road, Kingston, Surrey, U. K.
- MACLEAN, Dr., C. M. U.—*Medicine*.
Department of Social Medicine, University of Edin-
burgh, Usher Institute, Edinburgh, EH9 1DW, U. K.
- MARTINEZ, V.—*Technical information*.
Head, Servicio de Informacion Tecnica, CENDES,
P. O. Box 5833, Guayaquil, Ecuador.
- MCCOY, T. R.—*Appropriate technology applications*.
Canadian Hunger Foundation, 75 Sparks Street,
Ottawa, Ontario K1P 5A5, Canada.
- MCCUTCHEON, R. T.—*Education*.
Sussex University Mantell Building, Falmer, Brighton,
United Kingdom.
- MCKILLOP, R. F.—*Fishing*.
Department of Agriculture, Stocks and Fisheries,
P. O. Box 2417, Konedobu, Papua, New Guinea.
- MCMASTER, Dr., D. N.—*Rural technology*.
Centre of African Studies, University of Edinburgh,
Adam Ferguson Building, Edinburgh, EH8 9LL,
United Kingdom.
- MCROBIE, GEORGE—*Appropriate technology*.
ITDG, 9, King Street, London, W.C. 2, U. K.
- MERCHERT, MR.—*Appropriate technology seminars*.
German Foundation for International Development,
1 Berlin 27 Reihewerder, Berlin, Germany.
- MEYER, HANS—*Windmills for electricity and water pumping*.
Route 3, Box 329 Mukwonago, Wisconsin, U.S.A.
53149.
- MORGAN, JOHN—*Village technology*.
C/o Asere Hav satiat School, P. O. Box 21945, Addis
Ababa, Ethiopia.
- MULLER, JENS—*Regional planning, road building*.
Institute for Development Research, Vester Vold-
gade 104, DK 1552 Copenhagen, Denmark.
- NAPITUPULU, W. P.—*Village technologies*.
BUTSI Secretary, Tromol Pos 3290, Jakarta, Indo-
nesia.
- NCHINDA, Dr., T. C.—*Medicine*.
1a, Lynwood Road, London, SW 17 8SB, U. K.
- N'GANABET—*Rural industries*.
Directeur, Bureau de Promotion Industrielle du Tchad,
B. P. 458, N'Djamena, Tchad.
- NGODDY, P. O.—*Food engineering and processing*.
Senior Lecturer, University of Ife, Ife-Ife, Nigeria.
- NOLLE, JEAN—*Agricultural equipment*.
19, Ave due General Leclerc, Paris, France.
- NIIM, B. A.—*Village technologies*.
Deputy Director, Technology Consultancy Centre,
University of Science and Technology, Kumasi,
Ghana.
- OLATUNJI, F. D.—*Research*.
Federal Institute of Industrial Research, P. O. Lkeja,
Lagos, Nigeria.
- PACEY, A.—*Appropriate technology*.
Appropriate Technology Officer, Oxfam—U. K., 274
Banbury Road, Oxford, U. K., OX2 7DZ.

- PAILLON, R.—*Housing and Construction*.
Department of Housing and Planning Research,
Faculty of Architecture, University of Science and
Technology (UST), Kumasi, Ghana.
- PHILIP, K.—*Economics*.
Chairman, Industrialisation Fund for Developing
Countries, Bremerholm 4, Copenhagen, Denmark.
- PHILLIPS, D. A.—*Rural industry*.
Small Industries Development Organisation (S.I.D.O.),
P. O. Box 2476, Dar es Salaam, Tanzania.
- PIDGEON, EDWARD—*Rural development*.
25 Picard Place, Kingston, Ontario, K7M, 2W5,
Canada.
- PIKE, ALEXANDER—*Housing and Building*.
Technical Research Division, University of Cambridge,
Department of Architecture, 1 Scroppe Terrace,
Cambridge CB2 1PX, England.
- PO, CHUNG—*Methane generation*.
Specialist, Animal Industry Division, Joint Com-
mission on Rural Reconstruction, 37, Nan Hai Road,
Taipei, 107, Taiwan.
- POWELL, Dr. J. W.—*Rural technology*.
Director, Technology Consultancy Centre, University
of Science and Technology, Kumasi, Ghana.
Habitat and environment.
- PUTTEN, J. G. VAN—*Habitat*.
Chairman; NGO Committee for HABITAT
46, Wassenaarsweg, The Hague, 2013, Netherland.
- RANDELL, S. K.—*Building and construction*.
Supervisor, Reading Methods and Materials Centre,
University of Papua New Guinea, P. O. Box 4820,
Port Moresby, Papua New Guinea.
- RESSLER, E.—*Rural technologies, windmills*.
Director, Appropriate Technology Unit, P. O. Box
5674, Addis Ababa, Ethiopia.
- RILEY, NORMAN, J.—*Education*.
Coady International Institute, St. Francis Xavier
University, Antigonish, Nova Scotia, Canada.
- RITCHIE, JEAN—*Community development*.
FAO/PBFL, Regional Advisor, Woman's Programme,
United Nations Economic Commission for Africa,
Addis Ababa, Ethiopia.
- RODGER, A.—*Buildings*.
Department of Architecture, University of Edinburgh,
18 George Square, Edinburgh, EH8 9LE, United
Kingdom.
- ROY, A. D.—*Medicine*.
Department of Surgery, Institute of Clinical Science,
Queen's University, Grosvenor Road, Belfast, Ireland.
- RWEYEMAMY, J. F.—*Rural Technology*.
University of Dar es Salaam, Dar es Salaam, Tanzania.
- SCHUMACHER, Dr., E. F.—*Foremost thinker, philosopher
and guide of the intermediate technology movement in the world*.
Holcombe, Wealdway, Caterham, Surrey, U. K.
- SIGURDSON, JON—*Rural Industrialization*.
C/o Royal Swedish Academy, Engineering Sciences
Fack 5073, 102/42 Stockholm, Sweden.
- SHERMAN, MARCUS—*Windmills*.
The New Alchemists, Woods Hole,
Massachusetts 02543 U.S.A.
- SOEDJARWO, ANTON—*Village technology*.
Jalan Pacer A 67, Jogjakarta, Indonesia.
- SPENSLEY, Dr. P.—*Tropical products*.
Director, Tropical Products Institute, Culham, Abing-
don, Oxfordshire OX14 CDA U.K.
- TAPE, DR., NORMAN W.—*Food technology*.
Research Coordinator (Foods) Research Branch,
Canada Department of Agriculture, K. W. Neathy
Building, Ottawa, Ontario, K1A0C6, Canada.
- TEICHERT, B.—*Social work*.
Director, Evangelical Presbyterian Church Social
Centre, P. O. Box 224, Ho, Volta Region, Ghana.
- TEKLE-WOLD DEMEKE—*Rural technology*.
Director-General, Small-scale and Handicraft Indus-
tries, Ministry of Commerce, Industry and Tourism,
P. O. Box 1769, Addis Ababa, Ethiopia.
- TETTEH, Dr. P. A.—*Development Planning*.
Acting Head, Department of Planning, University of
Science and Technology (UST), Kumasi, Ghana.
- THOMPSON, R.—*Rural and village industries*.
Small Industries Corporation, C/o Ministry of Eco-
nomic Development, Government Buildings, Geor-
getown, Guyana.
- TODD, JOHN—*Recycling Waste and organic farming*.
Director, The New Alchemy Institute,
P. O. Box 432,
Woods Hole, Massachusetts 02543 U. S. A.
- VAN RENSBURG, PATRICK—*Education, village indus-
tries*.
Sarowe Brigades and Development Trsut, P. O. Box
121, Serowe, Botswana.
- VILLAGAS, BERNARDO, N.—*Economist, writer*.
Academic Director, Centre for Research and Com-
munication, Manila, Philippines.
- WEIR, ALEX—*Pedal power, agricultural equipment*.
Department of Agricultural Engineering, P. O.
Box 643, Morogoro, Tanzania.
- WIJEWARDENE RAY—*Agriculture Implements*.
International Institute of Tropical Agriculture,
P.M.B. 5320, Ibadan, Nigeria.
- WILLIAMS, C. M.—*Rural development*.
Senior Extension Specialist, Animal Science Depart-
ment, University of Saskatchewan, Saskatoon, Sas-
katchewan, Canada.
- WILLIAMS, PENNY—*Small scale technologies*.
Oxfam Quebec, 169 St. Paul East, Montreal, P.W.,
Canada.
- WINNINGTON, T. L.—*Rural technology*.
School of Engineering Science, University of Edin-
burgh, Kings Buildings, Mayfield Road, Edinburgh,
EH9 3 JL, U.K.
- WRIGHT, E.—*Agriculture*.
East of Scotland College of Agriculture, West Mains
Road, Edinburgh, EH9, 3J9, U.P.
- ZELMER LYNN—*Technology*.
P. O. Box 8268, Station Edmonton, Alberta, Canada.
- ZIEMEK, M. F.—*Technology*.
Planungsgruppe Ritter, Development Consultant,
Wiesbadenerstrasse 92, D 6240 Königstein in
Taunus, West Germany.

WORLD

GROUPS

- AFRICARE—*Study of African rural problems.*
1424, 16th Street, N. W. Suite 304, Washington, D.C.
20036.
- ALLAHABAD AGRICULTURAL INSTITUTE INC.—
Agriculture.
M. O. Centre, Stony Point, New York, N. Y., U.S.A.
- ANTIPOVERTY LIMITED—*Low-cost, labour-intensive
equipment.*
67 Godstow Road, Wolvercote, Oxford, OX2 8NY
England.
- APPLIED SCIENTIFIC RESEARCH CORPORATION OF THAILAND—*Rural industries.*
196, Phaholythin Road, Bang Khen, Bangkok 9,
Thailand.
- APPROPRIATE TECHNOLOGY GROUP—*Rural industries.*
9 Stanley Place, Minhana, Nugegoda, Sri Lanka.
- APPROPRIATE TECHNOLOGY CENTRE—*Development of appropriate technology.*
Ministry of Finance, Planning and Economic Affairs,
17-B, Satellite Town, Rawalpindi, Pakistan.
- APPROPRIATE TECHNOLOGY PROJECT—*Publishers of Appropriate Technology Sourcebook.*
Volunteers in Asia, Box 4543, Stanford, California,
94305, U.S.A.
- APPROPRIATE TECHNOLOGY UNIT—*Rural development.*
Christian Relief and Development Association P. O.
Box 5674, Addis Ababa, Ethiopia.
- BANGLADESH AGRICULTURAL RESEARCH COUNCIL—*Agriculture.*
Government of People's Republic of Bangladesh, 130/C
Dhanmondi, R/A Road No. 1, Dacca, Bangladesh.
- BRACE RESEARCH INSTITUTE—*Solar and wind
equipment for agriculture.*
MacDonald College of McGill University, Ste. Anne
de Bellevue, Quebec, Canada HOA 1G0.
- BRIARPATCH—*A group of people interested in simple living,
openness, sharing, using fewer resources.*
330 Ellis St., San Francisco, Ca. 94102, U.S.A.
- BUTSI—*Rural development.*
Badan Urusan Tenaga Keya Sukatela, Indonesia.
(Indonesian Board for Volunteer Service), Jalan
Halimun 4, Jakarta, Indonesia.
- C.A.D.U.—*Improved farm implements and small-scale industries.*
Chilalo Agricultural Development Unit, P. O. Box
3376, Addis Ababa, Ethiopia.
- CANADIAN HUNGER FOUNDATION—*Agriculture,
forestry, fisheries and nutrition.*
75 Sparks Street, Ottawa, Ontario, K1P 5A5, Canada.
- CARIBBEAN INDUSTRIAL RESEARCH INSTITUTE—*Rural industry research.*
University Post Office, St. Augustine, Trinidad, West
Indies.
- CATHOLIC FOREIGN MISSIONS—*Community Development.*
Mary Knoll, New York, U.S.A. 10543.
- CECOCO—*Agricultural processing machinery manufacturers.*
Chuo Boeki Goshi Kaisha, P. O. Box 8, Ibaraki City,
Osaka, Japan.
- CCPD—*Rural Development.*
Commission on the Churches Participation in Development,
World Council of Churches, Route de Ferney,
1211, Geneva-20, Switzerland.
- C.E.E.M.A.T.—*Agriculture, draft animals, methane gas.*
Centre D'etudes et D'experimentation du Machinisme
Agricole Tropical, Parc Tour vole, 92 Antony, France.
- CENTRO DE ESTUDIOS ECONOMICOS—*Studies on
SOCIALES DED TERSER MENDO third world*
Coronel Portivio Diaz Num. So
Saa Jeronimo Lidico, Mexico 20, D. F.
- CENTRE D'ETUDES ET DE PROMOTION DES
ENTERPRISES DAHOMEYENNES—*rural industries*
B. P. 2022, Contonou, Dahomey, West Africa.
- CENTRE FOR RESEARCH AND DEVELOPMENT
IN HOUSING, PLANNING AND BUILDING—
Rural and urban housing, tools, timber utilization.
Faculty of Architecture, University of Science and
Technology, Kumasi, Ghana.
- CENTRE NATIONAL DE PROMOTION E D
PETITES ET MOYENNES ENTERPRISES—*Small
industries.*
B. P. 1086, Lome, Togo, West Africa.
- CIRDA—*Agriculture development, soil fertility, land reclamation
and waste utilization.*
Centre International Pour le Development Agricole,
19 Rue Dufrenoy, 75116 Paris, France.
- CIREC—*Interdisciplinary research.*
Centre International de Recherche Sur l'Environnement
et le development, 94, Boulevard Raspail, 7 5270
Paris, France.
- CHRISTIAN AID—*Rural development*
2 Eaton Gate, London Sw1w 9BL
- CHRISTIAN ACTION FOR DEVELOPMENT IN
CARIBBEAN (CADEC)—*Rural development*
Post Office Box 616, Bridgetown, Barbados.
- COADY INTERNATIONAL INSTITUTE—*Co-operative,
adult education and local leadership.*
St. Francis Xavier University, Antigonish, Nova Scotia,
Canada.
- COMILLA ACADEMY—*Rural development*
Comilla, Bangladesh.
- COMMUNITY TECHNOLOGY INC.—*Urban agriculture,
roof top gardening.*
1520, New Hampshire Ave. N.W., Washington D. C.,
U.S.A. 20036.
- CONSERVATION TOOLS AND TECHNOLOGY—
*Solar heating, wind power, low energy housing and industrial
energy economy.*
143 Maple Road, Surbiton, Surrey KT 6 4 BH, United
Kingdom.
- DELTA FOUNDATION—*Rural development.*
819, North Main Street, Greenville, Mississippi,
38701.
- DEPARTMENT OF AGRICULTURE, STOCK AND
FISHERIES—*Agriculture, fishing, small-scale industry,
farmer organisations and education.*
P. O. Box 2417, Konedobu, Papua, New Guinea.

- DEVELOPMENT ACADEMY OF THE PHILIPPINES—*Rural development.*
3rd Floor, B. F., Condominium Bldg., Aduana Street, Intramuros, Manila, Philippines, 2801.
- DEVELOPMENT TECHNOLOGY CENTRE—*Solar energy, entrepreneur development.*
P. O. Box 276, Jalan Ganesha 10, Bandung, Indonesia.
- EARTHWORK—*Habitat.*
1499 Potrero Ave., San Francisco, CA 94110, U.S.A.
- ECOLOGY ACTION OF THE MID-PENINSULA—*Waste recycling, organic gardening, urban homesteading.*
2225 El Camino Real Palo Alto, California 94306, U.S.A.
- EDUCATIONAL SYSTEMS DEVELOPMENT CORPORATION—*Agriculture, family planning, rural health, nutrition, etc.*
7th Floor, Merchant Bank Building, 313 Buendia Ave., Makati, Rizals, D-711, Philippines.
- ENERGY PRIMER—*Solar, water, wind and bio-fuel.*
Portola Institute, 553, Santa Cruz Avenue, Menlo Park, Ca 94025, U.S.A.
- GARDEN WAY ASSOCIATES—*Handicrafts, gardening, food production and preservation.*
Charlotte, Vermont 05445, U.S.A.
- GEORGIA INSTITUTE OF TECHNOLOGY—*Professional research and guidance.*
Industrial Development Division Engineering Experiment Station, Atlanta, Georgia 30332, U.S.A.
- GERMAN FOUNDATION FOR INTERNATIONAL DEVELOPMENT—*Funds, seminars on appropriate technology and rural development.*
Berlin 27, Reihwerder, Berlin, Germany.
- GRUPE DE RECHERCHES SUR LES TECHNOLOGIES APPROPRIÉES—*Research.*
54 Rue de Varenne, Paris 75007, France.
- INDIA DEVELOPMENT GROUP, U.K.—*Rural development.*
12, Watermead Lane, Carsharlon, Surrey, U. K.
- INSTITUTE PERTANIAN BOGOR—*Agricultural tools.*
(Bogor Agricultural University), Fatemeta Jalan, Gunung Gede TLP BOT 571, Bogor, Malaysia.
- INSTITUTE FOR LOCAL SELF-RELIANCE—*Urban energy resources and water utilization.*
1717—18th Street, N. W., Washington D.C. 20009, U.S.A.
- INSTITUTE FOR POLICY STUDIES—*Science policy.*
1520 New Hampshire Avenue, Washington, D.C. 20036, U.S.A.
- INTERNATIONAL INSTITUTE OF RURAL RECONSTRUCTION—*Rural development.*
1775, Broadway, New York, 10019.
- INTERNATIONAL VOLUNTARY SERVICE INC.—*Rural development.*
1555 Connecticut Avenue, N. W., Washington, D.C. 20036.
- INTERCONTINENTAL EDUCATIONAL MEDIA—*Educational media.*
N.V.P.O. Box 52, Aerdehuout, The Netherlands.
- INTERMEDIATE TECHNOLOGY DEVELOPMENT GROUP (I.T.D.G.)—*Development of appropriate technology.*
9, King Street, London WC 2E, 8HN, U. K.
- INTERMEDIATE TECHNOLOGY WORKSHOPS—*Small industries and hospital equipment.*
P. O. Box 401, Waff Road, Zaria, North-Central State, Nigeria.
- INTERNATIONAL PLANT PROTECTION CENTRE—*Research into weed control systems.*
Oregon State University, Corvallis, Oregon 9733, U.S.A.
- INTERNATIONAL RICE RESEARCH INSTITUTE—*Rice production and management, small-scale machinery.*
P. O. Box 583, Manila, Philippines.
- LILLY ENDOWMENT, INC.—*Rural technology.*
2801 North Meridian Street, Indianapolis, Indiana 46208, U. S. A.
- LUSHOTO INTEGRATED DEVELOPMENT PROJECT—*Nutrition, rural development, marketing, village industries.*
P. O. Box 60, Soni, Tanzania.
- LUTHERAN WORLD FEDERATION—*Community development and education.*
150 Route de Ferney, 1211 Geneva 20, Switzerland.
- MARDI—*Agricultural machinery.*
Malaysian Agricultural Research and Development Institute, Jalan Marktab, Kuala Lumpur, Malaysia.
- NATIONAL INDUSTRIAL DEVELOPMENT CORPORATION—*Rural industries.*
P. O. Box 99, Malkerns, Swaziland, South Africa.
- NATURE ET PROGRES—*Centre for organic agriculture and related ecological methods of land use.*
3 Chemin de la Bergerie F. Sainte Genevieve des Bois France, 91700.
- NATURE ET VIE—*Village technology and agriculture.*
13 rue du Village Kervenanc, 5600 Lorient Bretagne, France.
- THE NEW ALCHEMISTS—*Organic farming and recycling of waste.*
P. O. Box 432, Woods Hole, Massachusetts 02543, U.S.A.
- OVERSEAS DEVELOPMENT COUNCIL—*Rural development.*
1717, Massachusetts Avenue, N. W., Washington, D.C., 20036.
- OFFICE OF APPROPRIATE TECHNOLOGY—*Rural technologies.*
Post Office Box 1677, Sacramento, California, 95808.
- OXFAM-AMERICA—*Rural development.*
302, Columbus Avenue, Post Office Box 228, Boston, Massachusetts 02116.
- INTERNATIONAL DEVELOPMENT AND RESEARCH CENTRE—*Research and rural industries.*
Post Office Box 8500, Canada, K1G 3H9.
- NATIONAL RURAL CENTRE—*Rural development.*
1200, 18th Street, N. W. Suite 610, Washington, D. C. 20036.
- PAKISTAN ACADEMY FOR RURAL DEVELOPMENT—*Rural Development.*
Peshawar, North-West Frontier Province, Pakistan.
- PARTNERSHIP FOR PRODUCTIVITY—*Rural development.*
Post Office Box 170, Annadale, Virginia 22003.
- PRIVATE AGENCIES COLLABORATING TOGETHER (PACT)—*Rural development.*
777 United Nation Plaza, New York, 10017.

- PROYECTO HUAYLAS—*Rural development.*
Av. La Mar, 963 Pueblo Libre Lima 21, Peru.
- RESEARCH POLICY PROGRAMME—*Research on rural problems.*
University of Lund, Solvegatan 8, S 223 62, Lund, Sweden.
- RURAL INDUSTRIES INNOVATION CENTRE—*Rural development.*
C/o Friederich-Ebert Foundation, P. O. Box 18, Gaborone, Botswana.
- SARVODAYA SHRAMADANA MOVEMENT—*Rural development.*
No. 77 De Soysa Road, Moratuwa, Sri Lanka.
- SEDOC—*Documentation.*
Servicio de Documentación Y Comunicación Rural, C.E.P.A. Ap. 2929, Managua, Nicaragua.
- SMALL INDUSTRIES DEVELOPMENT ORGANISATION—*Agriculture and small-scale industry.*
Shirika La Kuhudumia, Uwanda, Vidogo, P. O. Box 2476 Dar es Salaam, Tanzania.
- SMALL INDUSTRY CORPORATION—*Small industries.*
229 South Street, Lacytown, Georgetown, Guyana.
- THE SOIL ASSOCIATION—*Organic farming.*
Walnut Tree Manor, Houghtley, Stowmarket, Suffolk, U. K. IP 14 3RS
- TANZANIA AGRICULTURAL MACHINERY TESTING UNIT—*Small-scale industry and agricultural equipment.*
P. O. Box 1389, Arusha, Tanzania.
- TECHNOSERVE INC.—*Rural development.*
36 Old King's Highway South Darien, Connecticut, 06820. U. S. A.
- TECHNISCHE HOGESCHOOL EINDHOVEN—*Research.*
Micro-Projects Division, Postbus 513, Eindhoven, Girorekening 1076326, The Netherlands.
- TIBETAN FARM SCHOOL LIMITED—*Simple power sources.*
Brynoyre Talybout-on-Usk Breconshire, United Kingdom.
- TOOL—*Documentation.*
P. O. Box 525, Eindhoven, The Netherlands.
- T.W.O.—*Agriculture, housing, water supply, roads and bridges.*
Personeels Vereniging, Ing. Buro, D.H.V. Laan 1914 35 Amersfoort, Holland.
- UNECA—*Rural industries.*
Post Office Box 3001, Addis Ababa, Ethiopia.
- VILLAGE DESIGN—*Wind and solar energy work.*
1545, Dwight, Berkeley, California 94703, U.S.A.
- VITA, INC.—*Inquiry service on technical problems.*
Volunteers in Technical Assistance, 3706, Rhode Island Ave, Mt. Rainier, Md., U.S.A. 20822.
- VOLUNTARY COMMITTEE ON OVERSEAS AID AND DEVELOPMENT (VCOAD)—*Public education about development.*
International Development Centre, Parnell House, 25 Wilton Road, London SW1V 1JS, U.K.
- V.T.I.E.—*Rural technologies, windmills, forestry, animal husbandry, cottage industries.*
Village Technology Innovation Experiment, P. O. Box 31, Goat Hill, Addis Ababa, Ethiopia.
- WORLD NEIGHBOURS—*Co-operatives, credit unions community, development, food production and agriculture.*
5116 N. Portland Avenue, Oklahoma City, Oklahoma 73112, U.S.A.

**Members of the Executive Committee
of the
Appropriate Technology Development Association**

1.	Dr. Ram Das	Chairman	A-28, Friends Colony, New Delhi-110 014
2.	A. K. Karan	Vice-Chairman	Gandhi Bhawan, Lucknow
3.	M. K. Garg	Director (Projects) & Treasurer	C-10/1, River Bank Colony, Lucknow
4.	M. M. Hoda	Executive Director	Gandhi Bhawan, Lucknow
5.	V. S. Mathur	Member	P-20, Green Park Extension, New Delhi
6.	Devendra Kumar	„	Magan Sangrahalaya, Wardha-442 001
7.	Md Akram	„	A-2489, Netaji Nagar New Delhi
8.	Prof. S. M. Mohsin	„	Darulaman, Bhanwar- pokhar, Patna-4
9.	Hanuman Prasad	„	Organisation of the Rural Poor, Vill : Kusumih Kalan, Dist. Ghazipur
10.	Radhakrishna	„	Gandhi Peace Foundation, 221-223, Deen Dayal Upadhyaya Marg, New Delhi-110 002
11.	Bhagwant Singh	„	5, Tilak Marg, Lucknow