

DOCUMENT RESUME

ED 044 285

SE 009 798

AUTHOR Corliss, William R.
TITLE Space Radiation, Understanding the Atom Series.
INSTITUTION Atomic Energy Commission, Oak Ridge, Tenn. Div. of
Technical Information.
PUB DATE Jun 68
NOTE 63p.
AVAILABLE FROM U.S. Atomic Energy Commission, P.O. Box 62, Oak
Ridge, Tenn. 37830 (free)

EDRS PRICE EDRS Price MF-\$0.50 HC Not Available from EDRS.
DESCRIPTORS *Astronomy, *Earth Science, *Physical Sciences,
*Radiation, *Resource Materials, Science History,
Scientific Research, Solar Radiation
IDENTIFIERS Atomic Energy Commission

ABSTRACT

Described is the protection from space radiation afforded the earth by the atmosphere, ionosphere, and magnetic field. The importance of adequate instruments is emphasized by noting how refinements of radiation detection instruments was necessary for increased understanding of space radiation. The role of controversy and accident in the research is mentioned. A brief discussion of the safety of space travel concludes this illustrated booklet. A reading list is appended. (AL)

SPACE RADIATION

U.S. DEPARTMENT OF HEALTH, EDUCATION & WELFARE
OFFICE OF EDUCATION

THIS DOCUMENT HAS BEEN REPRODUCED EXACTLY AS RECEIVED FROM THE
PERSON OR ORGANIZATION ORIGINATING IT. POINTS OF VIEW OR OPINIONS
STATED DO NOT NECESSARILY REPRESENT OFFICIAL OFFICE OF EDUCATION
POSITION OR POLICY.

ATOMIC ENERGY COMMISSION Division of Technical Information

864 609 798
SE 009 38



**ONE
OF A SERIES ON
UNDERSTANDING
THE ATOM**

**UNITED STATES
ATOMIC ENERGY COMMISSION**

*Dr. Glenn T. Seaborg, Chairman
James T. Ramey
Dr. Gerald F. Tape
Wilfrid E. Johnson*

Nuclear energy
is playing a vital role
in the life of
every man, woman, and child
in the United States today.

In the years ahead
it will affect increasingly
all the peoples of the earth.

It is essential
that all Americans
gain an understanding
of this vital force if
they are to discharge thoughtfully
their responsibilities as citizens
and if they are to realize fully
the myriad benefits
that nuclear energy
offers them.

The United States
Atomic Energy Commission
provides this booklet
to help you achieve
such understanding.

Edward J. Brunenkant
Edward J. Brunenkant
Director
Division of Technical Information

ED0 44285

SPACE

RADIATION

Contents

- 1 INTERPLANETARY WEATHERMAKERS**
- 3 EARTH'S SNUG HARBOR**
- 11 SPACE RADIATION INSTRUMENT PRIMER**
- 15 TREMORS FROM WITHOUT**
- 30 THE IMPORTANCE OF MORE ALTITUDE**
- 37 THE GREAT MAGNETIC TRAP**
- 47 BEYOND THE GREAT RADIATION BELTS**
- 51 IS SPACE TRAVEL SAFE ?**
- 56 SUGGESTED REFERENCES**

Library of Congress Catalog Card Number: 68-60048

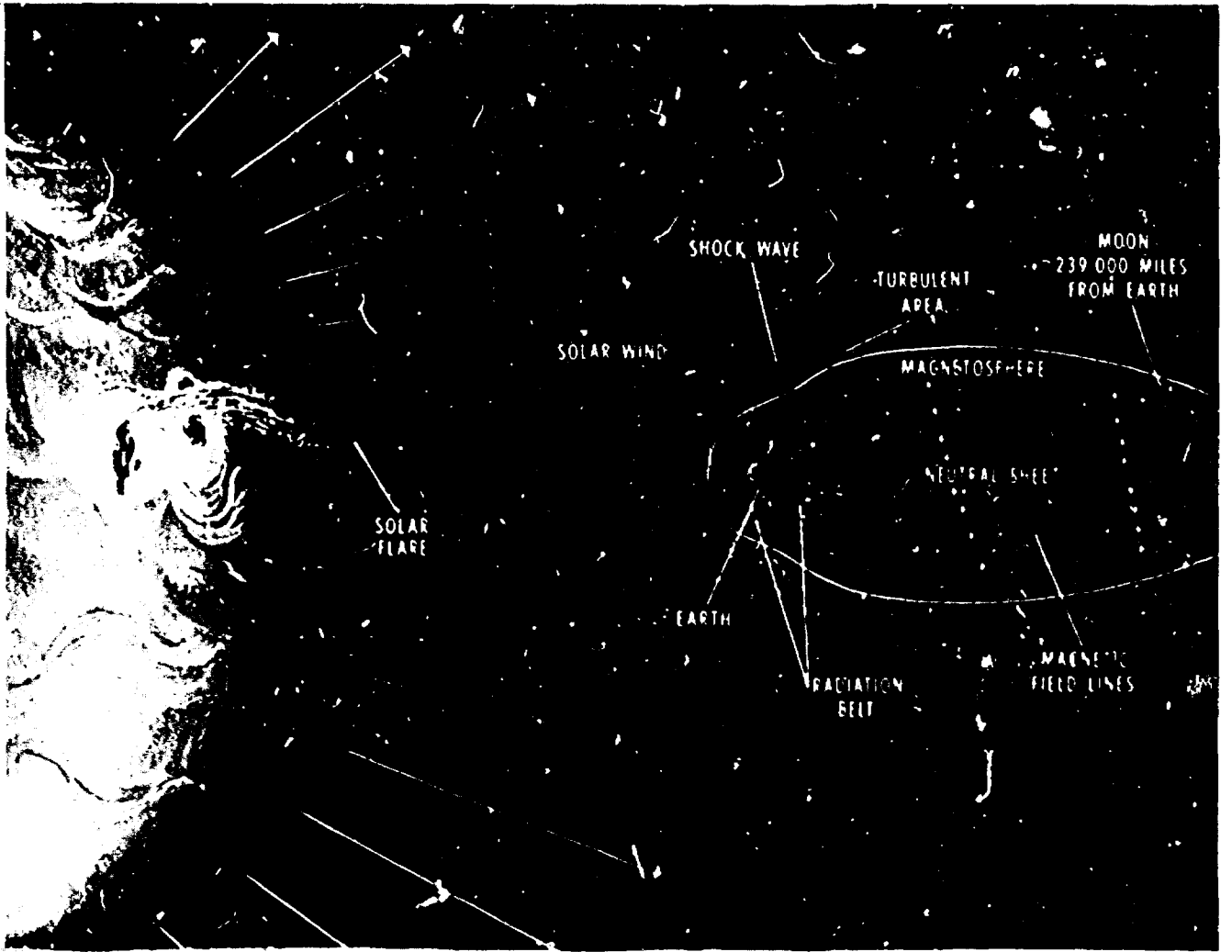

SPACE RADIATION

By WILLIAM R. CORLISS

INTERPLANETARY WEATHERMAKERS

Every second of your life you are pierced from head to toe by a score of minute projectiles. You cannot see, hear, or feel these subatomic bullets, but they bathe every square inch of the earth's surface with an invisible, unrelenting rain. Collectively, these penetrating particles are called *cosmic rays*. They come from the distant stars, and some began their journey even before the earth was born. They are the first kind of space radiation.

A second kind is encountered only by the astronauts as their capsules penetrate the great belts of protons and electrons that the earth has captured in its magnetic trap. Named after their discoverer, James A. Van Allen, the *Van Allen Belts* enshroud the earth and visibly announce their presence only when they "dump" some of their contents into the polar atmospheres and help kindle the auroras that light the winter skies.

← **Figure 1** The sun is the major "weathermaker" in outer space. Solar plasma tongues and cosmic rays are born during solar-flare eruptions. In addition, a steady "solar wind" is boiled off the sun's hot atmosphere. Galactic cosmic rays (not shown) come from the stars and arrive at the earth uniformly from all directions. (Distances on the diagram are obviously not to scale.)

Unmanned satellites and space probes radio back to us news of still a third kind of space radiation—*solar plasma*. Only when instrument carriers (and ultimately astronauts) break through an invisible, world-enveloping, teardrop-shaped barrier, called the *magnetopause*, can solar plasma be detected directly. Beyond this protective shell lies the open interplanetary sea, swept by a steady *solar wind* and lashed frequently by colossal tongues of plasma* that the sun spews out from convulsed regions on its surface. How did we learn about this celestial sea, and how can we travel to the planets through its storms?

Man was long oblivious to space radiation because of its invisibility. Cosmic rays, the Van Allen Belts, and the solar plasma were all great surprises when they were disclosed to a world long sheltered from interplanetary weather by our thick atmospheres. Now, however, the scents of each of these three quarries lure us along trails as intellectually fascinating and physically adventurous as any Antarctic expedition or voyage into the sea's depths.

*A plasma is a gaseous, electrically neutral mixture of positive and negative ions. See *Nuclear Terms, A Brief Glossary*, another booklet in this series, for meanings of unfamiliar words.

EARTH'S SNUG HARBOR

When a deep-space rocket, its fuel nearly gone, breaks through the earth's magnetopause into interplanetary space, it is like leaving the refuge of a good harbor and venturing out onto the open sea. The noun "sea" brings to mind steady trade winds, rolling ground swells, fickle currents, and storms. The analogy is indeed apt, for deep space has just these characteristics. On the earth's surface, we detect only a few subtle hints about what transpires beyond our three protecting "breakwaters": the *atmosphere*, the *ionosphere*, and the earth's *magnetic field* (Figure 1).

ATMOSPHERE The innermost barrier, the atmosphere, is an effective shield against both electromagnetic and particulate radiations. In weight, the atmosphere above us is equivalent to a layer of water about 34 feet deep. Most of it hugs the surface. A handy rule-of-thumb states that air density drops by a factor of ten for each 10 miles (16 kilometers) of altitude, up to 60 miles (100 km), where the air density is only about one millionth that at sea level. The thick, bottommost part of the atmosphere is the strongest part of the shield, since it is mainly collisions with the air's nitrogen and oxygen molecules that prevent the incoming photons* and charged particles from reaching the surface. This fact is readily proved by journeying up into mountainous country, say, to 9000 feet in Yosemite National Park, where, instruments show, one is pierced three times more frequently by cosmic rays than at sea level.

One of three things can happen when a charged particle or photon of energy enters the upper atmosphere from above. Collision with an air molecule may turn aside the incoming projectile, the molecule perhaps absorbing some of its energy in the process. This process is termed *scattering*; and if it occurs often enough a charged particle from outer space ultimately may lose most of its energy and settle down to become a permanent resident of the atmosphere. This is the fate of most of the low-energy particles hitting our atmo-

*A photon carries one quantum, or unit, of electromagnetic energy; it has no mass or electrical charge, but does have an effective momentum. Charged particles, by contrast, are minute constituents of matter, with measurable mass.

sphere. The kinetic energy they lose in collisions is often revealed as visible light in the upper atmosphere. The brilliant auroras and the hard-to-see airglow,* for example, may be due to stimulation of air molecules and atoms by extraterrestrial radiation.

Charged particles with somewhat higher energies may be *absorbed* rather than scattered by the nuclei of atoms in the atmosphere. Some particles in the cosmic-ray stream or flux are so energetic that they smash nitrogen and oxygen nuclei into many subatomic pieces, which then go on to do their own atom smashing. The result of a very energetic *primary* cosmic ray, then, is a shower or avalanche of *secondary* cosmic rays (Figure 2).

*The airglow is light from the sky that originates in the high atmosphere and is associated with photochemical reactions of gases caused by solar radiation.

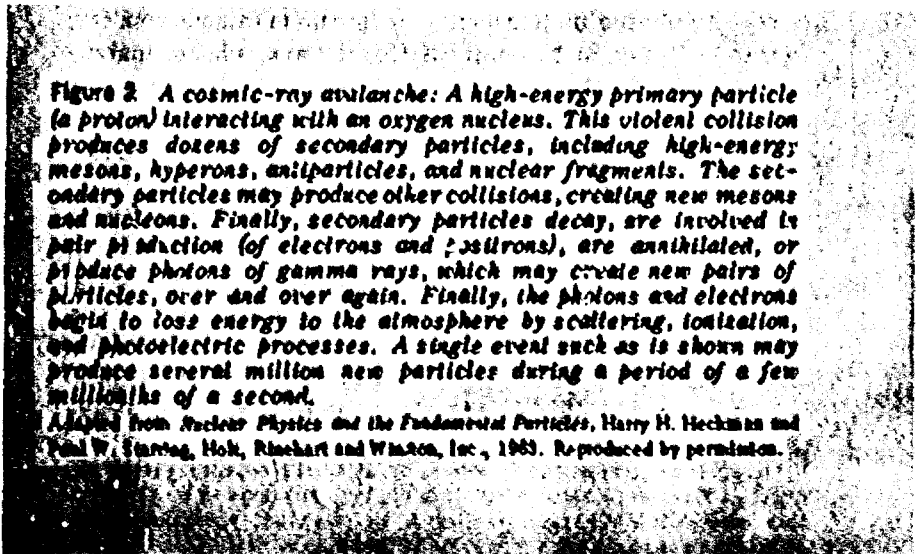
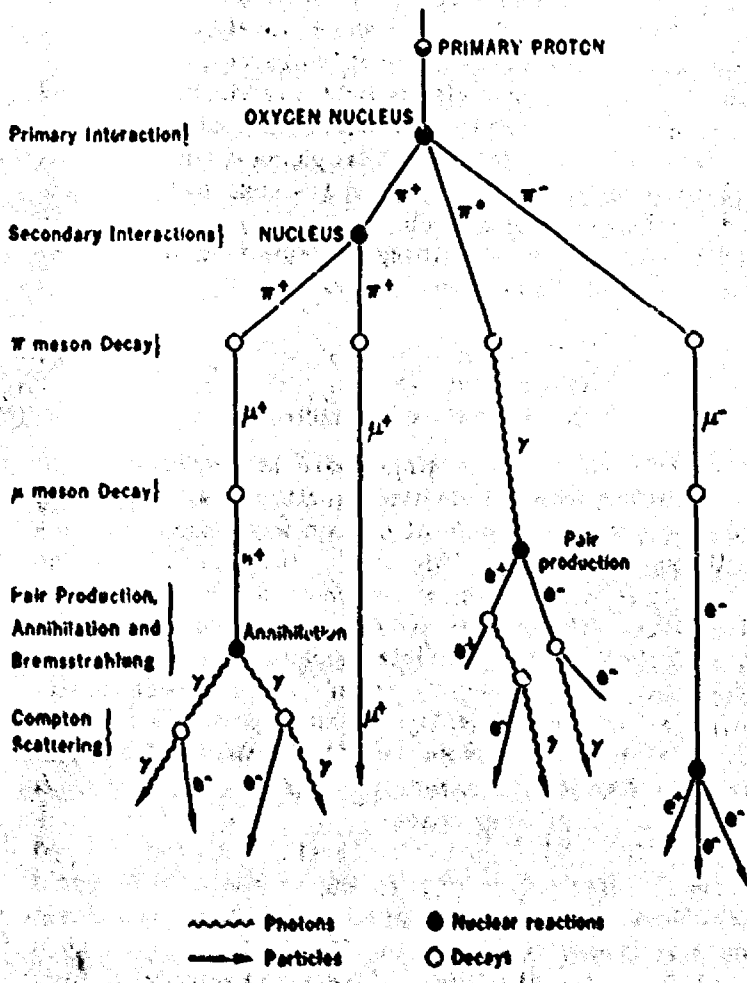

Figure 2. A cosmic-ray avalanche: A high-energy primary particle (a proton) interacting with an oxygen nucleus. This violent collision produces dozens of secondary particles, including high-energy mesons, hyperons, antiparticles, and nuclear fragments. The secondary particles may produce other collisions, creating new mesons and nucleons. Finally, secondary particles decay, are involved in pair production (of electrons and positrons), are annihilated, or produce photons of gamma rays, which may create new pairs of particles, over and over again. Finally, the photons and electrons begin to lose energy to the atmosphere by scattering, ionization, and photoelectric processes. A single event such as is shown may produce several million new particles during a period of a few millionths of a second.

Adapted from *Nuclear Physics and the Fundamental Particles*, Harry H. Heckman and Paul W. Sarting, Holt, Rinehart and Winston, Inc., 1963. Reproduced by permission.

A COSMIC RAY AVALANCHE



Photons from the sun and stars are also absorbed and scattered by molecules in the atmosphere. The blue sky is a familiar reminder that blue light is scattered away from the sun by atoms in the upper atmosphere. While most solar photons eventually reach the earth's surface in the form of visible sunlight, many short wavelength and long wavelength photons never make it. Infrared photons, with longer wavelengths than visible light, are readily absorbed in the high atmosphere by molecules, particularly those of water vapor. Some of the ultraviolet photons, which possess short wavelengths, collide with and are absorbed by oxygen (O_2) and nitrogen (N_2) molecules. The photon energy goes into the dissociation or splitting of diatomic molecules and the ionization of single atoms, as:

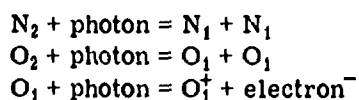

The overall effect of the atmosphere is insulation of the earth's surface from all electromagnetic radiation arriving from space, save for some at certain wavelengths that enters through atmospheric "windows"—that is, sections of the electromagnetic spectrum where photons are *not* absorbed in ionization, dissociation, and other processes (Figure 3).

It is fortunate that ultraviolet photons from the sun are stopped before they reach the earth's surface, because unfiltered solar ultraviolet light would be deadly to most terrestrial life. Astronauts must be protected from this ultraviolet flux just as carefully as they are shielded from the hard vacuum of outer space.

IONOSPHERE The short-wavelength radiation stopped high in the atmosphere creates the second of the earth's breakwaters. The ionization of oxygen and nitrogen atoms results in layers of unattached, "free" electrons, between 35 and 200 miles in altitude, which act as mirrors to low-frequency radio signals. Collectively, these layers are termed the ionosphere (Figure 4). When a radio wave from either the earth or outer space penetrates the ionosphere, it is bent away from its direction of propagation as the free electrons change the velocity of its wavefront. The lower the frequency and the more abundant the free electrons, the

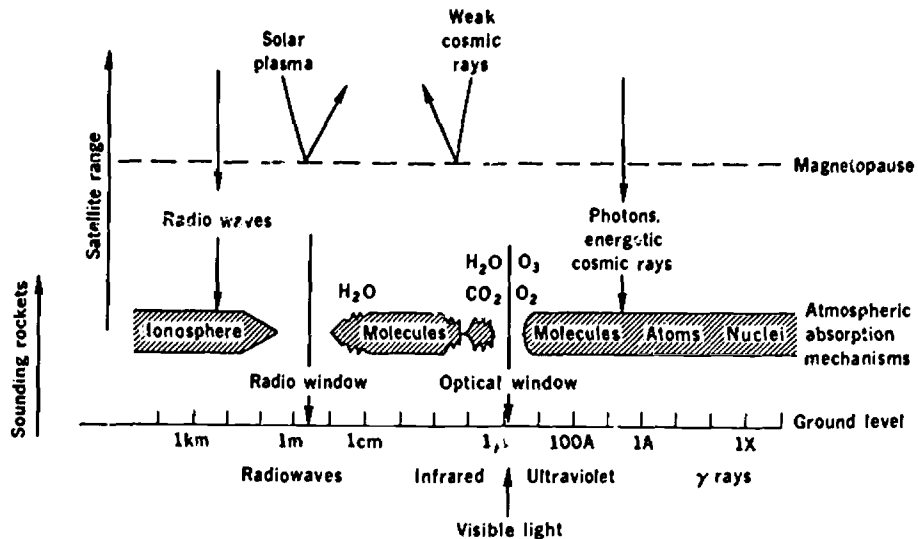

Figure 3 Most space radiation is absorbed or reflected by the earth's triple shield—the atmosphere, the ionosphere, and the magnetopause. Electromagnetic waves reach the earth's surface through a few very narrow "windows". Most particulate radiation is turned aside by the earth's magnetic field.

more sharply the radio waves are bent. Some are bent so far that they are reflected back in the direction from which they came. Without the reflecting power of the ionosphere, we would not have long distance transmission of radio signals below 20 megacycles per second (20 MHz).*

Although the ionosphere also reflects radio waves from deep space that are below 20 MHz and acts as a shield in this sense, we hardly need it for protection. The ionosphere, however innocuous it may be, is a distinct nuisance to radio astronomers because it blinds them to all the tantalizing low-frequency radio waves emitted by the stars and galaxies, and narrows the radio "window" through which we can "see" the universe. Thus the ionosphere wraps the earth in yet another muffling layer of insulation.

*1 MHz = 1 megaHertz = 1 megacycle per second = 1,000,000 cycles per second; named for Heinrich R. Hertz, German physicist who discovered electromagnetic waves.

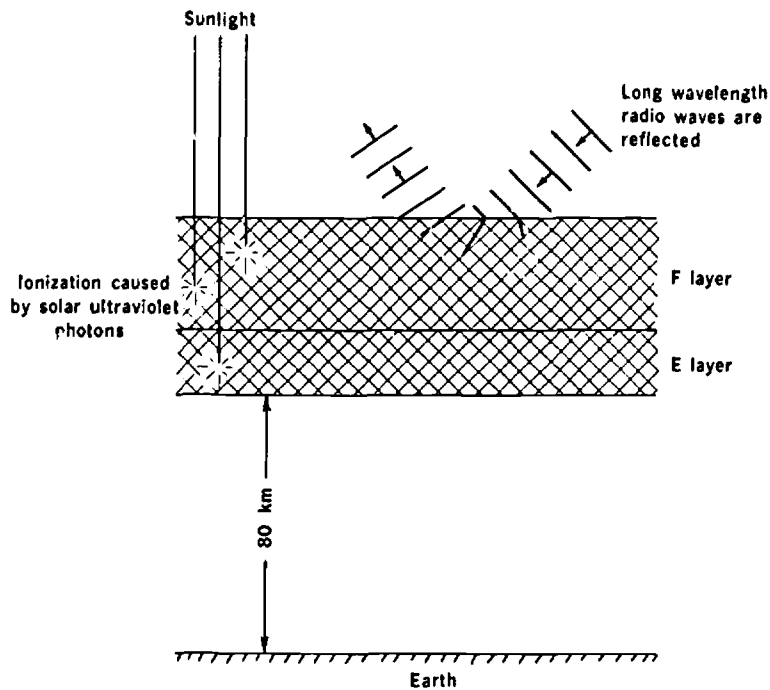

Figure 4 *The ionosphere is created when short wavelength solar photons ionize oxygen and nitrogen high in the atmosphere. Long wavelength radiowaves speed up when they penetrate these layers containing many free electrons. Consequently, the wavefronts bend away from the initial direction of travel and the radiowaves may be reflected.*

MAGNETOPAUSE The third and last barrier that separates terrestrials from the sights and sounds of the interplanetary expanses, the earth's magnetic field, has none of the substance of the layers of free electrons in the ionosphere or of the material atmosphere beneath. The earth's magnetic field originates inside our planet's rocky mantle, perhaps through the dynamo action of immense subterranean electrical currents, and extends thousands of miles out into space. The external field can be pictured by imagining lines of force that emerge from one magnetic pole and curve around the earth to reenter at the opposite magnetic pole (Figure 5). Before the Space Age began, the external mag-

netic field was visualized as one that would result from a bar magnet imbedded in the solid earth, but displaced some 11° from the axis of rotation. The field was thought to be symmetric around the magnetic poles and it was assumed it extended to infinity. Later paragraphs will show how data obtained by satellites have forced drastic revision of this idealized portrait.

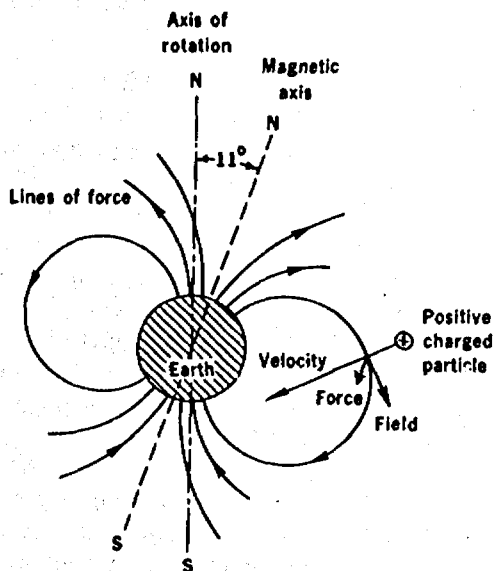

Figure 5 The magnetic field of the earth is canted about 11° with respect to the axis of rotation. The precise positions of the magnetic poles vary with time. An incoming charged particle will be forced off a straight trajectory as shown.

The ideal dipole field shown in Figure 5 is nevertheless close enough to reality to support the magnetic shielding story that follows. The key to understanding magnetic shielding is recognition that the path of an electrically charged particle is bent *at right angles* to both the direction of the magnetic field and the direction in which the particle

travels. The bending force, F , is given by a simple equation:

$$F = qvB \cos(v,B)$$

where q = the electrical charge in coulombs*

v = the particle velocity in meters per second

B = the magnetic field strength in webers† per square meter

$\cos(v,B)$ = the cosine of the angle between the velocity of the particle and the direction of the magnetic field

The resulting force, F , is perpendicular to both v and B .

A charged particle approaching the earth from space will be turned away if it is aimed at the equator. On the other hand, it would not be deflected at all if it arrived on a path parallel to the earth's magnetic axis at the poles. The earth, then, is enclosed within a magnetic shield that is open at the poles and strongest in the equatorial regions. The solar wind never even reaches the earth's upper atmosphere because its weak (but not innocuous) charged particles are easily turned away by the magnetic lines of force. Energetic primary cosmic rays, however, zip right through as if there were no field around us at all.

But all this is getting ahead of the story. At the turn of this century, had you suggested at a scientific meeting that the earth was under intense bombardment by cosmic projectiles you would have been laughed out of the room. For the science of 1900, like the earth, also was well "insulated" from all forms of space radiation by the three barriers just described. There was a conviction among scientists that space radiation did not and could not exist. Still, a few wispy clues penetrated this insulation and there were some scientists who could not resist following them to the tops of mountains, the bottoms of lakes, and high into the stratosphere.

*The coulomb is a unit of electrical charge named for Charles A. de Coulomb, French physicist.

†The weber is a unit of magnetic flux named for Wilhelm E. Weber, German physicist.

SPACE RADIATION INSTRUMENT PRIMER

The overwhelming majority of all particulate space radiation consists of high-speed electrons, protons, and alpha particles, the last species consisting of helium atoms stripped of their electrons. Out of every hundred primary cosmic-ray particles perhaps two are similarly stripped nuclei of heavier-than-helium atoms. The Van Allen Belts and the solar plasma are almost exclusively composed of electrons and protons.

The experimental problem is how to measure the numbers, speeds, and directions of travel of each component of this radiation. In technical terms, we want to know the radiation flux (the number of particles crossing a square centimeter area each second) as a function of particle energy, direction of travel, and species.

Since the minute targets of these particles cannot be seen directly, we can only search for the debris left behind as they plow through matter. This is like estimating a tornado's winds by studying its path of destruction. A high-speed particle leaves a trail of ions behind it, the number per centimeter of path depending upon the particle species and its velocity. The operation of most radiation instruments depends upon these short-lived tracks of sundered atoms and the phenomena that take place when they recombine.

The primitive electroscope (Figure 6) measures the cumulative ionization created by all particles passing through it. As ions and electrons in the filler gas drift

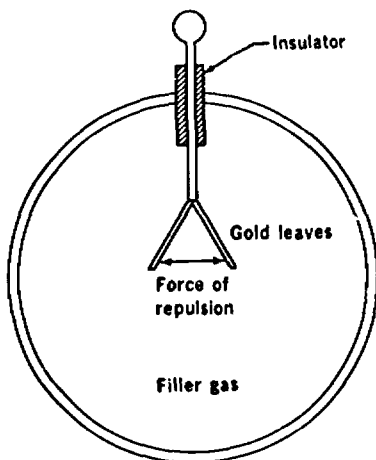
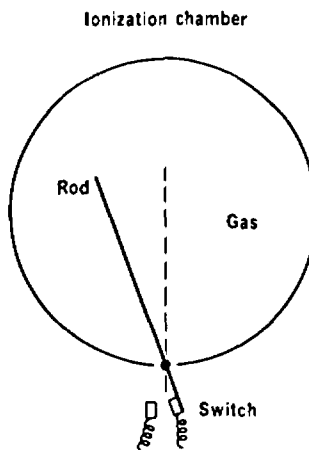

Figure 6 *The classical gold-leaf electroscope. Cosmic rays were first detected when researchers could not keep their electroscopes charged.*

toward the oppositely charged gold leaves, the leaves are neutralized and subsequently collapse when the force of electrostatic repulsion weakens. The rate of collapse is proportional to the rate ions are created within the electro-scope.

Modern space ionization chambers also measure the rate of ionization within the chamber walls. In a volley-ball-sized ionization chamber, a central collector rod and surrounding walls supplant the electro-scope's gold leaves (see sketch). The chamber discharges as ions and electrons are attracted to the charged rod and walls. As the pivoted central rod edges toward its discharge position, it trips a switch that sends a pulse of electric current to the satellite's telemetry system and also recharges the chamber. Note that an ionization chamber does not reveal particle numbers, energies, directions, or species by itself.

On satellites, the ionization chamber is frequently associated with a Geiger-Müller (GM) counter that totals the number of ionizing particles in the vicinity. Imagine the ionization chamber pulled out into the shape of a cylinder. When a charged particle deposits a trail of ions and electrons in a GM tube, the voltage applied between the central wire and the walls accelerates the electrons to such high speeds that they collide with neutral atoms in the filler gas and ionize them. These *secondary electrons* also go on to cause more ionization. On the process goes—avalanche fashion—until the whole tube is filled with ionized gas. The passage of a single particle thus *discharges* the GM tube and creates an electrical pulse that is fed to the satellite telemetry circuits. A comparison of the total rate of energy deposited in the ionization chamber with the number of particles in the vicinity yields the average particle energy.



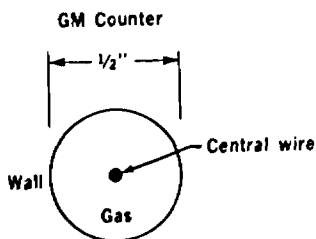

A scintillator crystal gives the experimenter a somewhat better estimate of particle energy. Each particle, passing through a crystal made, say, of thallium-activated cesium iodide, CsI(Tl), leaves the usual trail of ions and electrons. But when these ions and electrons recombine, a flash of light (a *scintillation*) is

emitted that is proportional in intensity to the amount of energy deposited in the crystal. The flash is usually measured by an adjacent photomultiplier tube. If the crystal is thick enough to stop the incident particle, the magnitude of the flash is proportional to the particle's entire supply of energy.

Both scintillators and GM counters are often arranged linearly to help determine particle direction. In such a *telescope*, a particle is recorded only when it triggers the linear elements in what is termed a *coincidence*. Telescopes are thus sensitive to particle direction-of-arrival. The combination of thin scintillators, intervening absorbers, and a thick scintillator can give a scientist all he needs to determine particle flux, energy, direction of arrival, and species.

Electrons and protons in the solar plasma and parts of the Van Allen Belts are generally not fast enough to penetrate GM counters and scintillator telescopes. Slow charged particles are measured by *plasma probes* that collect the incoming charged particles in cups (called Faraday cups) and on spherical electrodes. The minute electric current created by the collected charges is proportional to the flux. To make plasma probes discriminate against protons and electrons of different energies, the potential differences between the probe grids are automatically stepped between

Scintillation counter

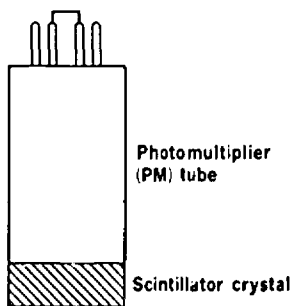

between the probe grids are automatically stepped between different levels. An increasing positive potential on the outside grid would, for example, repel protons of ever greater energies over the probe's cycle of operation. In effect, plasma probes are electrostatic filters of charged particles.

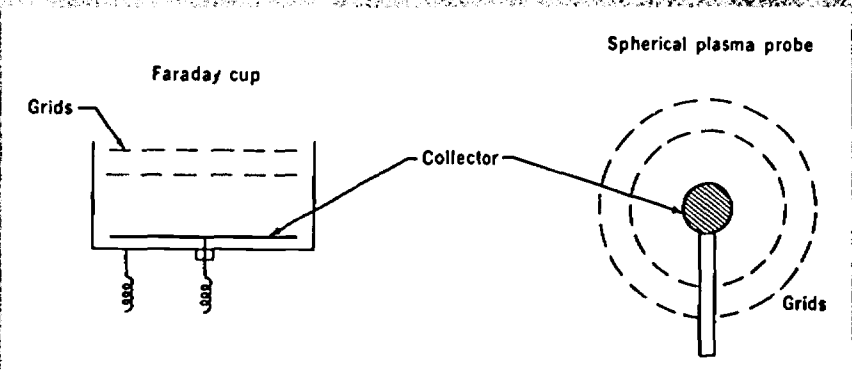
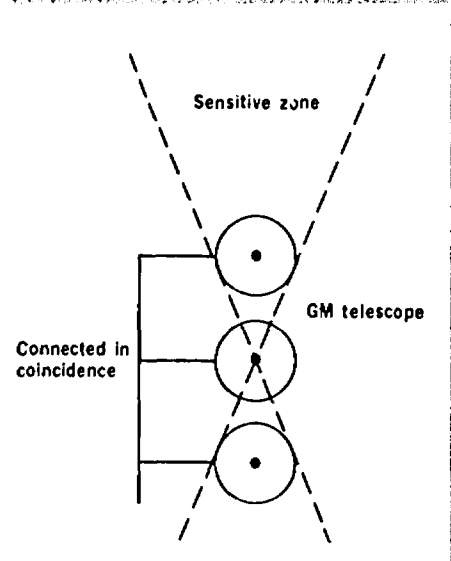
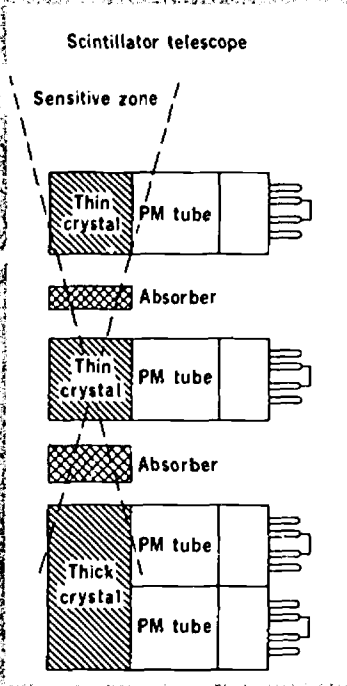

TREMORS FROM WITHOUT

Today's scientific laboratories brim with clicking Geiger counters and picture-taking bubble chambers. Nuclear radiation is a real thing to us because, although ordinarily we cannot detect it directly with our God-given senses, we have contrived a myriad of instruments to extend our faculties into regions where we are naturally blind.

Before 1900, however, the idea that minute solid objects could pass through one's body and leave the shadows of one's bones on a photographic plate was incredible—perhaps as unbelievable as the dream of heavier-than-air flying machines. Nonetheless, Wilhelm Roentgen *had* discovered his invisible, penetrating X rays in 1895, and Henri Becquerel *had* found radioactivity, with its subtle, unseen emanations, a year later. Scientists began to realize that a whole new world lay just below the threshold of human senses; detecting radiation was like grappling with ghosts.

The Mystery of the Collapsing Gold Leaves

The “ghostly” radiation registered on only two instruments common in turn-of-the-century laboratories: photographic film and the electroscope. Charged particles and photons plowing through a photographic emulsion left trails of “excited” molecules behind them. Development of the film made these tracks visible. Becquerel proved the existence of natural radioactivity by taking photographs of keys and other dense objects with the invisible radiations given off by disintegrating atoms.

The electroscope was a different instrument altogether. When charged particles and penetrating photons pass into an electroscope chamber, they ionize the enclosed gas and allow the electroscope to discharge (Figure 6). The quantity of radiation can be crudely measured by watching the rate at which the gold leaves collapse. Neither photographic emulsions nor electroscopes record the passage of individual particles; rather they register the effects of many particles over a relatively long period of time.

Early experimenters with radiation were troubled by the perplexing tendency of electroscopes to discharge slowly in the absence of any known source of radiation. In other

words, the air inside the electroscopes was always slightly ionized. Charles T. R. Wilson, inventor of the cloud chamber, was one of the early researchers who puzzled over this strange phenomenon. Even when the ions in the electroscopes were neutralized intentionally, new ones continually formed, indicating a constant source of radiation from *somewhere*. Heavy shields around the electroscopes reduced somewhat the rate at which the electroscopes discharged. But the unknown radiation was much more penetrating than that from X-ray tubes or natural radioactivity. For many years, scientists believed that this mysterious flux of photons or particles came from the earth itself, the laboratory walls, and even the materials used in constructing the electroscopes. Almost everyone looked down instead of up.

But not everyone was happy with the general agreement. In 1903, S. P. Thompson suggested in the periodical *Science* that charged particles originating on the sun might be driven by the pressure of light traveling across interplanetary space to arrive at the earth as highly penetrating radiation. The English physicist, Sir Owen W. Richardson, suggested in *Nature* in 1906 that the sun might be responsible for the affliction of terrestrial electroscopes. More than suggestions were necessary to sway the consensus, however.

Quivering Compass Needles

While most physicists were satisfied with terrestrial explanations of their newly found penetrating radiation, others detected a few extraterrestrial currents slipping through the earth's triple ring of breakwaters. When rough lodestones had been replaced by more sensitive compass needles, navigators on land and sea quickly noted that even the best needles were never still. They wandered slightly and quivered; sometimes a needle would be relatively quiet for days, then some unseen force would shake it violently. As far back as 1759, John Canton, a London schoolmaster, had discovered that the more energetic excursions of his compass needle occurred when the northern lights were conspicuous. It seemed likely that the same phenomenon that stimulated the auroras also shook compass needles—whatever that phenomenon might be.

Almost a hundred years passed after Canton's observation before scientists realized that the sun might be reaching across 93,000,000 miles and 'ostling the earth. On March 18, 1852, Major General Edward Sabine submitted a report to the Royal Society bearing the murky title: "On Periodical Laws Discernible in the Mean Effects of the Larger Magnetic Disturbances". What the General had found from his magnetic studies in Canada was that magnetic storms were more frequent when there were lots of sunspots. In other words, the sunspot and magnetic cycles of activity were similar. Subsequent studies showed that auroras, sunspots, and nervous compass needles were synchronized. This was the first strong hint that some unseen radiation from the sun was affecting the earth.

Lights in the Polar Skies

The polar auroras with their flickering flames and glowing draperies have always been known by man (Figure 7). Despite the fact that satellites fly above them and sounding rockets continually pierce them from below, the auroras have still not yielded to detailed explanation. A few things seem sure: The auroras are associated with solar and geomagnetic activity and present us with the only visible (and sometimes audible) manifestations of the great radiation belts that surround our planet.

In our reference year of 1900, the physical connection between solar activity and terrestrial magnetic storms was not understood. Somehow the sun perturbed the earth's magnetic field across a void 93,000,000 miles wide. The auroras provided the evidence—so clear now in retrospect—that electrically charged particles spit out by the sun were the stimulus. One has only to look at the shape of the earth's dipole field to see that the weakest chinks in the magnetic armor exist at the magnetic poles where the lines of force intersect the earth's surface. The auroras occur most often between magnetic (not geographical) latitudes of 65° and 70° ; that is, in a ring-shaped band about each magnetic pole. Whatever causes the auroras obviously is strongly affected by magnetic fields; and only charged particles have this response. Coupling this observation with the strong correlation between auroras, the 11-year sunspot cycle, and the



Figure 7 *Auroral arcs over the home of the president of the University of Alaska, College, Alaska.*

frequency of solar flares, it seems inescapable that eruptions of charged particles from the sun have something to do with igniting the auroras.

Alas, science seems so easy looking backward in time, but in the early 1900s no one had yet put these pieces of the puzzle together. Perhaps it was because many physicists were fighting a three-headed hydra—three great challenges to the established order of thinking:

(1) *Radioactivity*, which dispelled the idea of immutable atomic nuclei;

(2) *Relativity*, which replaced Isaac Newton's solid, absolute world; and

(3) *The quantum theory*, which maintained that the world progressed in fits and starts rather than smoothly and continuously.

In short, the great synthesizers of science were too busy adjusting old beliefs to new harnesses to worry about stray breezes from the interplanetary sea.

A Turn-of-the-Century Recapitulation

1. A persistent, highly penetrating radiation had made itself known by discharging electrometers. This radiation seemed to come from the earth itself.

2. Storms and activity on the sun somehow agitated the earth's magnetic field.

3. The mysterious and strangely beautiful auroras were also connected with solar and geomagnetic activity.

With these clues began what Pierre Auger, one of the great French physicists of the period, dubbed "The Heroic Epoch".

A New Sport: Scientific Ballooning

As Europe moved quietly and unknowingly toward World War I, doubts accumulated about the supposition that natural radioactivity in the earth caused electroscopes to discharge. By 1907, electroscopes had been improved to the point where they could withstand the rigors of travel. In that year, the Canadian scientist, John C. McLennan, carried his electroscopes out onto the thick winter ice of Lake Ontario. The expectation was that the electroscopes would no longer discharge because the natural radioactivity in the rocks and soil would be screened by hundreds of feet of nonradioactive water. McLennan's measurements did show a definite decrease in the discharge rate, but the electrometers persisted in discharging slightly. McLennan even used electroscopes made of different materials to test the possibility that natural radioactivity in the electroscope itself might be the culprit — all to no avail, the electrometers kept discharging. McLennan was forced to conclude that although some of the invisible radiation came from rocks and soil, another component originated either in the atmosphere or outer space. In 1908, A. S. Eve, another Canadian, took electroscopes out onto the open ocean and obtained similar results.

New World science and scientists made little impression in Europe at this point in history, and most Europeans continued to hold tenaciously to the idea that terrestrial radioactivity was the sole cause of discharging electroscopes. When Thomas Wulf, a German scientist, electrometer in hand, ascended the Eiffel Tower in 1910, he fully expected that it would discharge at a slower and slower rate as he left terrestrial radioactivity behind on the ground. Albert

Gockel, a Swiss physicist, expected the same result when he began his balloon ascents and — naturally — when he climbed the Matterhorn in 1909. Both investigators were startled to find that the rate of electroscope discharge did indeed decrease, although not nearly as rapidly as they expected. In effect, Wulf and Gockel repeated McLennan's experiment, except that they interposed air rather than water between electroscope and the radioactive mantle of the earth. The radioactivity hypothesis was now suspect in Europe as well as America.

Most physicists, meanwhile, continued to study the fluctuations of their electroscopes, preferring the security of their laboratories to risky balloon ascents. Discoveries in geophysics, however, are not made by the stay-at-homes. Just as Darwin needed the far-ranging voyage of H.M.S. *Beagle* to find grist for his theory of evolution, physicists had to leave hearth and home to discover space radiation.

The Aust-ian-American physicist, Victor F. Hess, combined a zeal for exploration with scientific ability. Beginning in 1911, Hess carried electroscopes far higher in the atmosphere than had any of his airborne predecessors. His memorable flight of August 1912 produced data that shocked his earthbound comrades. As Hess's balloon rose, the rate of electroscope discharge decreased, just as Wulf and Gockel had already established. But above 2000 feet, his electroscopes began to discharge *faster*, indicating an *increase* in the radiation level around the balloon. At 16,000 feet the radiation level was four times that measured on the ground!

Hess interpreted his results in this way: The initial reduction in radiation level was due to leaving terrestrial radioactivity behind, and the marked increase above 2000 feet was due to extraterrestrial radiation. Hess's facts were soon supported by balloon observations of Werner Kolhörster, another important pioneer in space radiation. For his lighter-than-air exploits, Hess ultimately shared the 1936 Nobel Prize in physics with Carl Anderson, discoverer of the positron.*

*A positively charged particle, the "anti-electron". Anderson, Millikan's pupil, discovered it while using a special cloud chamber he devised for cosmic-ray studies.

The reports of Hess and Kolhörster raised a storm of controversy. If extraterrestrial radiation existed, argued the skeptics, there would be obvious daily variations in the radiation levels on earth as the radiation sources moved across the sky. No such variations had ever been found. An alternative (and supposedly more reasonable) interpretation was proposed: There were strong sources of radiation in the high atmosphere. Perhaps radioactive gases, such as radon, were concentrated in the stratosphere. Charles T. R. Wilson suggested that high-altitude thunderstorms might be the source. Obviously, more experiments were in order.

Beneath the Mountain Lakes

During World War I, pursuit of the Höhenstrahlung (radiation from on high) found by Hess and his colleagues had to be broken off. Despite the solid experimental evidence, many scientists still challenged the thought of extraterrestrial radiation. Wherever this new penetrating radiation was measured, it appeared to be remarkably uniform as the days, seasons, and years passed. No celestial source would show such steadfastness, these men felt.

One of the skeptics was Robert A. Millikan, a physics professor at the California Institute of Technology. Millikan decided in the mid-1920s to show once and for all that the Höhenstrahlung was either terrestrial, atmospheric, or extraterrestrial in origin. A classic series of experiments between 1923 and 1926 satisfied Millikan and nearly everyone else that the *cosmic rays*, as Millikan termed them, truly came from the cosmos (the universe) and not the earth. Of course, the fact that Millikan had just received the 1923 Nobel Prize, for his simple but ingenious experiment for measuring the charge on the electron, may have had something to do with the acceptance of his work, although acceptance was far from immediate and complete.

Millikan and his team moved straightway to high altitudes. Aircraft and balloons were placed in service. In particular, Millikan pioneered the use of *sounding balloons* for cosmic-ray work, rather than the less convenient manned balloons. In one series of free balloon flights, Millikan's apparatus consisted of a recording electroscope, a thermograph, a barograph, photographic film, and a clock—all *weighing*

only 7 ounces. In his handicraft, Millikan pioneered in instrument miniaturization, later so crucial to rocket and satellite work.

It was not, however, the data from his sophisticated airborne experiments that convinced Millikan of the true nature of the cosmic rays. His experiments at Arrowhead and Muir Lakes in California's San Bernardino mountain range were more compelling. These two lakes were at 5100 and 11,800 feet, respectively, where the cosmic-ray flux was much higher than at sea level. In addition, the lakes were snowed, precluding contamination by impurities from radioactive terrestrial rocks. Another experimental bonus resulted from Millikan's choice: Arrowhead and Muir Lakes were surrounded by high mountains that formed, in effect, a natural "telescope"; that is, radiation reaching Millikan's instruments at any instant had to come from a narrow region of the sky.

First of all, Millikan's data showed with great precision that the radiation levels at various depths in Muir Lake correlated beautifully with those taken in Arrowhead, *provided he used Arrowhead depths 6 feet nearer the surface*. These 6 feet of water were just equivalent in mass (and supposedly in attenuating, or braking, capability) to the additional 6700 feet of air that existed above Arrowhead. This agreement of measurements indicated that no radioactive sources of radiation resided in the 6700 feet of air over Arrowhead Lake (Figure 8). Since the source of cosmic rays was neither in the earth or its atmosphere, Millikan concluded that the radiation was coming from outer space.*

Millikan's electrometers also indicated that cosmic rays persisted far below the lakes' surfaces. The cosmic rays must therefore be much more penetrating than any known terrestrial radiations. Theory required that the wavelengths be short—so much shorter than the shortest gamma rays known that some scientists would not believe Millikan's results, regardless of his Nobel Prize.

*Actually, equal masses of air and water do not have precisely the same shielding capabilities, but this was not known in Millikan's day. If it had been, Millikan might have reached different conclusions.

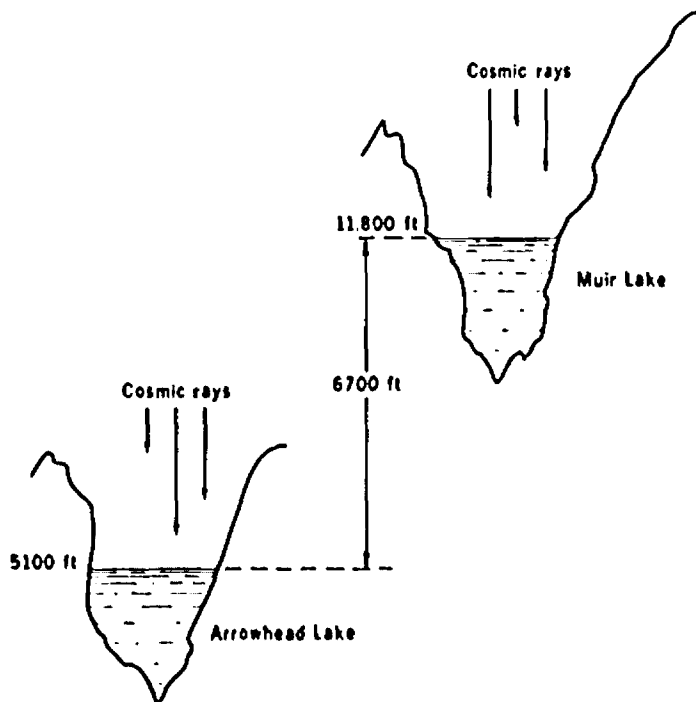

Figure 8 Millikan's experiments in the mountain lakes.

Another controversial conclusion was born as the earth turned and the narrow sector above each mountain lake swept across new portions of the celestial sphere. Millikan detected no changes in cosmic-ray intensity no matter where the earth pointed his rock-walled telescope. His conclusion was that the cosmic rays come uniformly from *all* space, not just the sun and the Milky Way.

By 1928, Millikan had hypothesized that cosmic rays were created during the synthesis of heavy elements from primordial hydrogen throughout the universe. Cosmic rays were the "birth cry" of matter, he said. This inference, as we shall see, eventually succumbed when better experimental data were taken.

A fascinating sidelight to this phase of cosmic-ray study was Millikan's self-assurance. He was always annoyingly certain that his techniques and results were better than

anyone else's—and he was often right. Nevertheless, his diplomacy was wanting and he ruffled many a scientific feather. Kolhörster, in particular, vigorously attacked Millikan's results. European scientists were outraged when American papers began calling cosmic rays *Millikan Rays*. Eventually, though, most of Millikan's work was accepted all over the world.

Existence Granted, But What Are They?

By the late 1920s, most of the scientific community conceded that cosmic rays did indeed exist. Almost equally universal was the belief that cosmic rays were high-energy photons, that is, gamma rays rather than charged particles. The discovery that they were not, like many scientific bonanzas, was accidental.

One of the players in this little drama was Werner Kolhörster, the same German physicist who had attacked Millikan's ideas so violently. Collaborating with Kolhörster was Walther Bothe, another German physicist, who was to share the 1954 Nobel Prize for his role. Also vital to the story, though they did not participate directly in the "unplanned" discovery, were Hans Geiger and one of his students, H. Müller, who, in 1929, finally perfected a radiation counter. The Geiger-Müller (GM) counter is now an essential instrument in all radiation laboratories.*

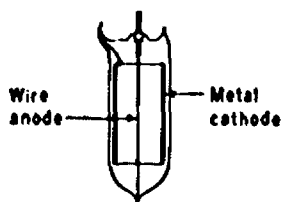

Geiger-Müller counter

Prior to 1929, high-energy photons and particles were made "visible" to man mainly through electroscopes, photographic film, cloud chambers, and ionization chambers. Scientists had to determine the nature of this fleeting, unseeable radiation from pointer readings and the wispy tracks caught by film and cloud

*Hans Geiger, Ernest Rutherford, and others had worked on instruments similar to the GM counter as early as 1908. The 1929 GM counter, however, was the first reliable "event" counter to come into general use.

chamber. The electroscope, ionization chamber, and film were "integrating" instruments that toted up the sum of all particle and photon traffic through the instrument over a period of time. The cloud chamber, in contrast, took "snapshots" of the radiation fluxes at isolated moments of time. Before the GM counter was developed, scientists could not make continuous traffic counts of specific particles. The perfection of the GM counter added a whole new dimension to radiation experimentation. (See *Space Radiation Instrument Primer*, p. 11).

Bothe and Kolhörster were experimenting with GM counters and electroscopes when they found to their surprise that two GM counters, placed one above the other, often discharged simultaneously. Such *coincidences* could not be entirely due to chance because they became much less frequent as the vertical distance between the counters was increased. Bothe and Kolhörster concluded that each coincidence represented the nearly simultaneous passage of a high-speed particle or photon through *both* counters. Since the radiation was very penetrating and came from above, they reasoned that individual cosmic-ray events probably were responsible. But were the discharges due to photons of high energy or charged particles?

The next experiment was planned rather than accidental. Bothe and Kolhörster inserted a gold brick 4.1 cm thick between the two GM counters. Even with the gold brick's high stopping power, the rate of coincidences decreased only 24%. If the cosmic rays consisted of photons, the decrease should have been significantly larger. Bothe and Kolhörster surmised that cosmic rays were high-speed, charged particles—a concept contrary to general belief in 1930.

Bruno Rossi, a noted Italian cosmic-ray scientist relates in his book *Cosmic Rays* how the famous paper of Bothe and Kolhörster affected him: The paper "came like a flash of light revealing the existence of an unsuspected world, full of mysteries, which no one had yet begun to explore. It soon became my overwhelming ambition to participate in the exploration". (See Suggested References, page 56).

One of Rossi's subsequent contributions was the demonstration that most primary cosmic rays could penetrate a full meter of lead at sea level. This fact implied that

cosmic-ray energies were in the billion-electron-volt range, thousands of times greater than any radiation released during the synthesis of matter. Millikan's suggestion that cosmic rays represented the birth cry of interstellar matter thus fell before the onslaught of experimental facts.

Carl Störmer and the Terrellas

Strangely enough, the groundwork for the next step in cosmic-ray research had been laid by a Norwegian geophysicist back in the days when physicists were still puzzled by electroscopes that discharged for no apparent reason. Like his scientific contemporaries Carl Störmer had no idea that a steady flux of high-energy cosmic rays enveloped the earth; he was trying to explain the aurora as a manifestation of terrestrial bombardment by low-energy, sun-emitted particles. It turned out that Störmer's work was more appropriate to cosmic rays than to auroras.

Störmer's approach was this: Suppose that a charged particle is heading toward the earth from a great distance — that is, from mathematical infinity in theory, but from the sun in actuality. At the turn of the century, everyone believed that the earth's dipole magnetic field extended deep into interplanetary space, so Störmer thought the magnetic forces tended to bend the particles off their initially straight courses. The mathematics was complicated and tedious, and occupied much of Störmer's professional career, but he was able to compute a great many trajectories that demonstrated (theoretically at least) how charged particles would approach the earth (Figure 9).

Two important conclusions emerged: (1) Charged particles should be deflected away from the earth's equator toward the poles. Thus, radiation detectors at the same elevations but different latitudes should record more cosmic rays near the poles. (2) "Forbidden zones" appeared that extraterrestrial charged particles in theory could not penetrate. Furthermore, particles occupying these zones could not escape, assuming they could somehow invade them. The forbidden zones are, of course, the zones of "trapped" radiation that were to surprise James Van Allen in early 1958. To Störmer these zones were of no interest because he supposed particles could not enter them.

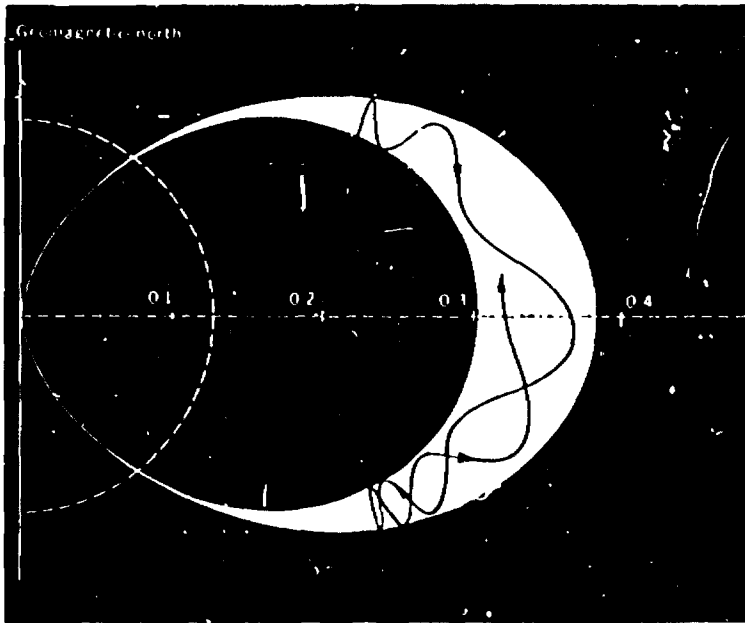

Figure 9 Carl Störmer's diagram shows how the particles could spiral back and forth between geomagnetic poles, if they could somehow enter these "forbidden" zones.

In his laborious computations Störmer was able to draw on the work of the French mathematician, Jules Henri Poincaré, who had calculated the motion of charged particles in a unipole field in 1896. In the same year, Kristian Birkeland, a Norwegian physicist, had experimentally demonstrated how cathode rays (negative electrons) would move under the influence of both a unipole and dipole. Birkeland in fact simulated the earth's field with a magnetized "terrella", a sphere with a dipole field (Figure 10). Störmer's calculations were thus supported in the laboratory. In the context of understanding cosmic rays, the important point of his work was the predicted "latitude effect", that is, that higher cosmic-ray levels would be found near the poles.

The trouble was that the latitude effect seemed nonexistent. In 1925, Millikan had measured cosmic rays at Los Angeles, Mollendo, Peru, and Churchill, Manitoba, without finding any changes above and beyond those that might be



Figure 10 *Aterrella* experiment. A magneted sphere representing the earth is placed in a vacuum chamber and bombarded with charged particles that make the streaks of light shown. In this view, looking down at a magnetic pole, an equatorial ring of captured particles is apparent. This photo was made by William H. Bennett with his "Störmertron".

hidden by his instruments' errors. He had therefore concluded (erroneously) that cosmic rays were photonic in nature. Bothe and Kolhörster also took their instruments toward the poles only to have the latitude effect escape them. On the other hand, a Dutch physicist, J. Clay, sailed from Amsterdam to Batavia in 1927 and claimed to have discovered rather large changes in cosmic-ray intensity along his route. Who was right? Paradoxically, they all were.

Arthur H. Compton, an American physicist, had already won the Nobel Prize (in 1927) when he turned his attention to cosmic rays in 1930. Compton's approach to the latitude problem was to make *many* earth-circling trips, measuring the cosmic-ray intensity with high precision as he went. He summarized his lengthy research with a worldwide "map" that showed lines of equal cosmic-ray intensity (isocosms) (Figure 11). Compton's map showed that Millikan, Bothe, and Kolhörster had travelled paths where changes in cosmic-ray intensity were so small that they were hidden

amid normal experimental errors. Clay, on the other hand, most opportunely had journeyed along a favorable path and was quite correct in his assertion that he had discovered a latitude effect. The latitude effect actually is rather small (see Figure 11) and is tilted along with the geomagnetic field by about 11° with respect to geographical latitude. It at last seemed definite that the earth's magnetic field *did* bend the paths of cosmic rays and they *were* charged particles rather than photons.

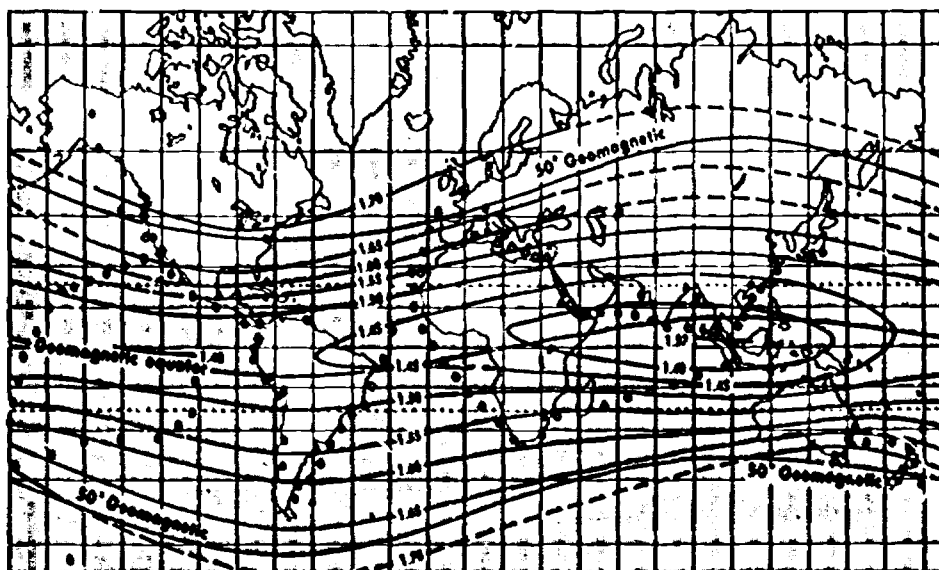

Figure 11 One of Compton's early maps of worldwide cosmic-ray intensity. The curves, called isocosms, are lines of equal intensity measured in numbers of ion pairs produced in each cubic centimeter of standard air per second. Note that the isocosms generally parallel the magnetic latitudes.

Many other details about cosmic rays were discovered between Compton's work and the beginning of the Space Age. Mainly, researchers concentrated on the effects of cosmic rays in the atmosphere and the great showers of secondary particles they produce. This booklet is more concerned with radiation above the atmosphere and our next step must be upward—up beyond the layers that insulate us from deep space.

THE IMPORTANCE OF MORE ALTITUDE

As the rich period of between-the-wars cosmic-ray research drew to a close in the late 1930s, balloons and aircraft had carried detection instruments up to 10 miles. Beyond was unknown territory. Expectation was that only a uniform flux of primary cosmic rays would register on flights to higher altitudes. It was felt there would, of course, be fewer showers of secondaries and less magnetic bending of trajectories as instruments were propelled farther into space. However, the auroras still defied scientific explanation and some scientists had become quite wary about predicting too confidently what might be discovered in new physical realms. World War II provided the ideal vehicle—the rocket—for exploring the regions above the limits of balloons and aircraft.

Beating Vengeance Weapons into Instrument Carriers

In 1940 rockets were not new to warfare or to upper atmosphere research. The Chinese reputedly employed war rockets as far back as 1000 A.D. The American rocket pioneer, Robert Goddard, installed instruments on some of his primitive liquid-fueled rockets as early as July 17, 1929. On this date a Goddard rocket transported a recording thermometer and barometer to the "tremendous" height of 90 feet; this was the first sounding rocket. The significant contribution of World War II to rocket research was the development of *large* rockets capable of breaching the atmosphere completely and, for the first time, reaching into outer space itself.

The major rocket of World War II was Hitler's Vengeance Weapon 2, more popularly known as the V-2. During operational flights, the V-2 carried up to 1650 pounds of amatol explosive to an altitude of 50 miles over a relatively shallow trajectory toward Britain. Aimed straight up, the V-2 could carry scientific instruments to perhaps 100 miles. The scientific possibilities were enticing (Figure 12).

At the close of World War II, captured V-2's were brought to the United States along with the German team that had developed them. The V-2's went to the Army's White Sands

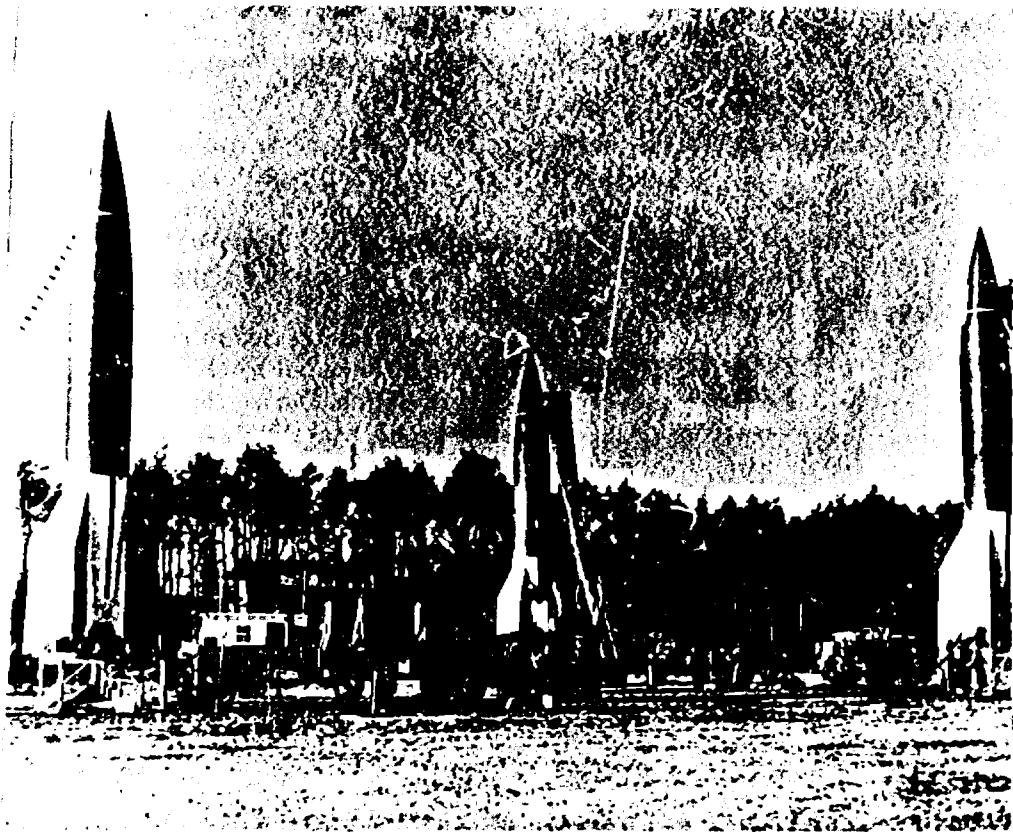

Figure 12 *German V-2 military rockets, shown here deployed for firing against Britain, were converted into sounding rockets after the war. Over 60 were fired from White Sands, New Mexico, carrying a great variety of scientific instruments.*

Proving Ground where test firings commenced in 1946. Although rocket knowhow rather than scientific research was the main object of these shots, many kinds of instruments were carried aloft and recovered. James A. Van Allen, then at Johns Hopkins University,* and scientists at the Naval Research Laboratory contributed cosmic-ray instrumentation for several of these V-2 firings. In general, the V-2 cosmic-ray data held no surprises, but they did give experimenters a chance to develop rugged miniature instruments and to perfect the art of radiotelemetry. Van Allen's group did not realize it, but their V-2 shots had arced over

*Van Allen is now at the State University of Iowa.

and descended to earth just short of a major discovery. Some V-2 flights, particularly those of Project Bumper, which employed a second-stage solid rocket, rose to 244 miles above the earth. Unfortunately, all V-2 launches were at relatively low latitudes, where the earth's magnetic lines of force bow spaceward the farthest.

In 1952, Van Allen's group began a second series of rocket flights that took them no higher in altitude but much closer to the elusive zones of trapped radiation. During the summers of 1952-1955, the Iowa group sent off 42 *Rockoon* flights at *high latitudes*. The intent was to launch cosmic-ray instruments high into the polar skies to measure low-energy cosmic rays deflected into the auroral regions by the earth's magnetic field. Because the captured V-2's had all been expended in the White Sands tests, the idea of firing a relatively small rocket from a high-altitude balloon was proposed. In the *Rockoon* concept, a 12-inch diameter Deacon solid-fuel rocket was suspended below a large Skyhook balloon and lifted to about 60,000 feet, where it was fired, by remote control, upward *through* the balloon (Figure 13). With the bulk of the atmosphere below the air-buoyed "launch pad", the Deacon could easily reach 50 miles. The idea sounded good, and it was supported by the Atomic En-



Figure 13 A *Rockoon* ascending from the Coast Guard Cutter East Wind during Van Allen's polar experiments in the early 1950s. Note the ship's yardarm in the upper left.

ergy Commission, the Office of Naval Research, and the National Science Foundation. The first Rockoon flights rose from the Coast Guard cutter *East Wind* off Greenland in 1952. Later flights covered the geomagnetic latitudes between 55.6° and the north geomagnetic pole (Figure 14).

Van Allen and his colleagues analyzed the telemetry data from their GM counters aboard the Rockoons and concluded that considerable soft (or low-energy) radiation existed in the regions over the geomagnetic poles. The radiation was assumed to be low-energy electrons. The desire to explore further this unexpectedly high concentration of electrons was one of the moving forces behind Project Vanguard, the first U. S. satellite program.

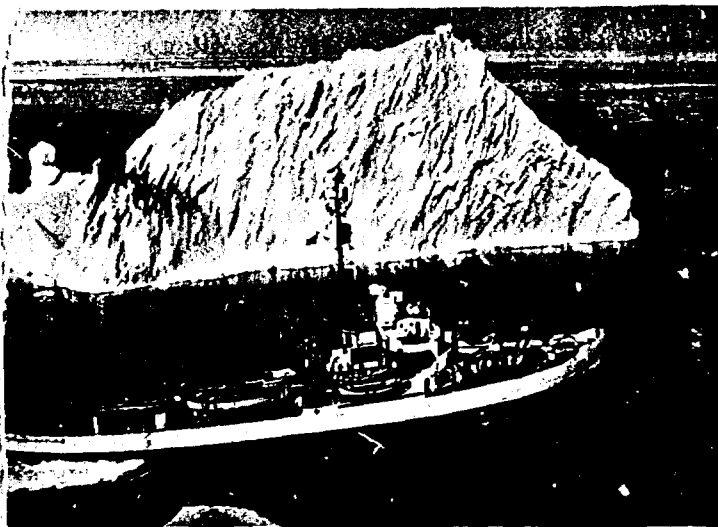

Figure 14 (a) The Coast Guard Cutter *East Wind* near Greenland on the 1952 Van Allen cosmic-ray expedition. (b) Van Allen (on the right) and the Deacon rocket, which is to be carried high aloft by a balloon on a Rockoon flight.



While Van Allen was seeking support for an American satellite effort during the forthcoming International Geophysical Year (1957-1958), Fred Singer, an American physicist, was involved in Project Farside. The object of Farside was the launch of a rocket probe to an altitude of several hundred miles. Singer wished to include instruments that would search for the soft radiation that had been detected by Van Allen. Singer presumed (correctly) that he would find this radiation farther away from the earth at lower latitudes. It is rather ironical that a Farside shot in October 1957 from Eniwetok Island in the Pacific penetrated well into the still undiscovered region of trapped radiation but did not carry a GM counter. If it had, the Van Allen Belts might be named the Singer Belts! The Explorer 1 satellite, carrying Van Allen's GM counters, was launched just a few weeks later, in January 1958. Van Allen and Singer, of course, did not know that they were in a "race" toward one of the major discoveries of the Space Age.

Pre-Sputnik Expectations

Just what did the scientists expect to find with satellite radiation detectors? In the main, they looked for nothing significantly different from the data balloons and rockets had already placed on the record books, that is, primary cosmic rays, including more of the soft component found by Van Allen during his polar rocket work. By the end of 1957, however, there was a considerable body of theoretical work supporting the existence of zones about the earth where charged particles could be trapped for long periods of time. No one then had direct evidence of trapped particles, but the possibility of their existence could not be denied.

The important analytical work from 1905 onward had been carried out by Carl Störmer, as already explained. A number of independent laboratory experiments with terrellas had repeatedly confirmed the reality of Störmer's "forbidden zones". In fact, these simulation experiments clearly showed that charged particles from the bombarding source somehow managed to penetrate into the forbidden zone and become "trapped" (Figure 10).

To these theoretical approaches must be added the "ring current" hypothesis that Störmer and others had developed

to explain geomagnetic disturbances. In this theory, charged particles in satellite orbit about the earth would generate secondary fields that would strengthen or weaken the earth's field, just as a current in a solenoid weakens or strengthens an electromagnet's field. The ring current theory was not widely accepted in 1957, and few people expected satellites to find such a current.

The work of three other physicists was available in 1957 that in retrospect makes the discovery of the Van Allen Belts seem unavoidable. In 1947, the famous Swedish astrophysicist, Hannes Alfvén, had shown how cosmic-ray charged particles could be magnetically *scattered* into forbidden zones by interplanetary matter. Thus, one mechanism for populating the trapped zones was available. Fred Singer proposed two more mechanisms in 1956: Single particles might not be able to penetrate into the forbidden zones but several could through "collective" action, that is, by mutual electromagnetic interaction between nearby particles.

Singer's second approach was the "neutron albedo" mechanism for adding particles to the forbidden zones.* In this, neutrons are created in the earth's upper atmosphere as primary cosmic-ray particles collide with nuclei of air atoms. Some neutrons are emitted upward and pass through the forbidden zones. The neutron is not a stable particle, possessing a half-life of only 11.3 minutes, and decaying into a proton, an electron, and a neutrino. During its passage through the forbidden zone, then, the neutron may disintegrate and inject an electron and/or a proton into the trapped zone (Figure 15).

Shortly after Singer made his proposals, Nicholas Christofilos,† suggested in a then secret Atomic Energy Commission report that small nuclear weapons detonated at high altitudes could populate the forbidden zones with charged particles. Christofilos presented a detailed theory showing how these artificially created particles would eventually be lost as they collided with atmospheric

*The Russians Lebedinsky and Vernov also proposed the neutron albedo theory about the same time as Singer.

†A scientist at the AEC's Lawrence Radiation Laboratory in Livermore, California.

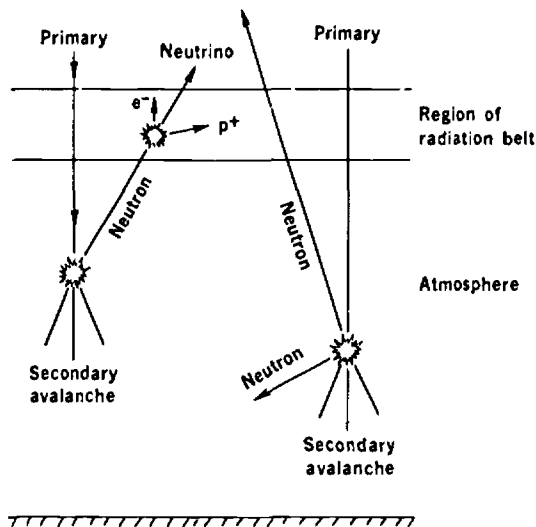

Figure 15 In the "neutron albedo" theory, a primary cosmic ray passes through the radiation belts and collides with a nucleus in the atmosphere. Some of the secondary particles produced are neutrons, and a few decay as they pass through the radiation belt region. The protons released during neutron decay are frequently trapped by the earth's magnetic field and help populate the inner Van Allen belt.

molecules. Christofilos also recognized that the cosmic-ray albedo neutrons could provide a source of charged particles. The report by Christofilos did not become available to other scientists, however, until after the Argus series of high-altitude nuclear explosions in 1958.

Thus, on the day Sputnik 1* was launched, it was well known that charged particles could be magnetically trapped in zones around the earth, but there was no direct evidence that such particles were really out there. All the mechanisms proposed for populating the zones were reasonable, but, despite all this preparation, final confirmation of the reality of the Van Allen Belts came as quite a surprise. Moreover, the trapped zones were larger and more heavily populated with high-energy particles than anyone had suspected.

*Sputnik 1, launched by Russia, was the first man-made satellite. The date, Oct. 4, 1957, opened the Space Age.

THE GREAT MAGNETIC TRAP

The Jammed GMs on Explorer 1

Sputnik 1 was the first man-made contrivance to reach orbit, but, if it carried radiation detectors, the Russians have never disclosed the fact. In about 4 weeks, on November 3, 1957, Sputnik 2 followed Sputnik 1 into orbit. This time the spacecraft carried a doomed dog and also some radiation detectors. In 1958 the Russian scientist S. N. Vernov, reported that Sputnik 2 had registered considerable soft cosmic radiation at high altitudes, similar to that Van Allen had found with his polar rockets. If Sputnik 2 had been within radio range of Russian telemetry stations when it reached its highest altitudes, Vernov would have had the distinction of reporting the discovery of the radiation belts. Sputnik 2 was just too low as it passed over the Soviet Union beeping out its instrument readings.

Meanwhile, the shock of the Sputnik successes had stimulated the United States into organizing a second satellite effort to back up the Vanguard Program. Explorer 1, the first satellite in this program, propelled one of Van Allen's GM tubes into a 1584-by-234-mile orbit on January 31, 1958.

Figure 16 *The Explorer 4 satellite, showing the sensor package containing the radiation counters. Explorers 1, 3, and 4 (essentially identical) were approximately 67 inches long.*

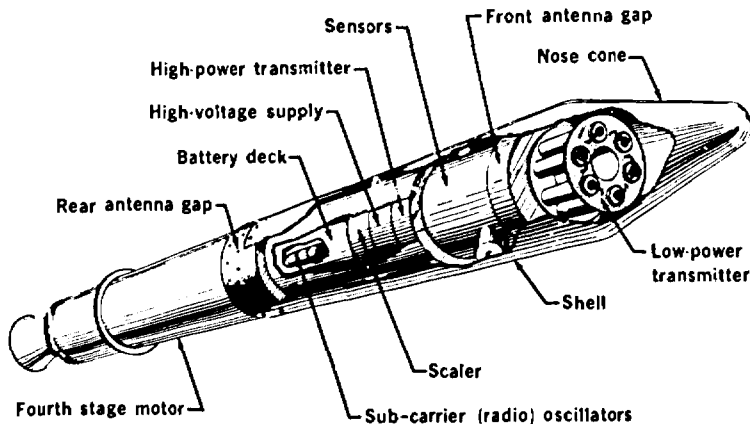

The telemetry signals received from Explorer 1 indicated radiation levels were pretty much as expected for cosmic rays, as long as the satellite remained below 370 miles (600 km). Above 500 miles (800 km) the radiation levels increased dramatically. In fact, the radiation was so intense at high altitudes that the GM tube was "saturated", that is, so many particles pierced the tube that it discharged continuously. As a result the telemetry showed *no* GM counts at all at very high altitudes. Equipment malfunction was suspected, but because the tube started counting again as the satellite reached lower altitudes, saturation was a more reasonable explanation. In order to jam the Explorer 1 GM counter, the radiation levels had to be some 15,000 times that expected from primary cosmic rays!

In a landmark talk given on May 1, 1958, to a special joint meeting of the National Academy of Sciences and the American Physical Society in Washington, D. C., Van Allen concluded that the earth was surrounded by intense belts of trapped radiation. In this way, finding the second of the three major kinds of space radiation was disclosed. And again, the discovery had been generally unexpected.

Mapping the Van Allen Belts

The first "map" of the Van Allen Belts was constructed with the help of data from the Explorer 4 satellite and the space probe, Pioneer 3. Certainly one of the most widely published results of space research, the map displayed contours of equal counting rates that were symmetric around the earth's geomagnetic axis (Figure 17). Two zones of especially intense radiation were found: An inner, kidney-shaped belt and an outer crescent-shaped belt. "Horns" poked down into the earth's atmosphere in the vicinity of the auroral zones.

Contours are very nice, but *what* was the GM tube counting? GM tubes can count both electrons and protons with high efficiency, but do not discriminate between them.*

*Photons were ruled out as belt constituents because they could not be trapped by the magnetic field.

Neither does a GM pulse reveal anything about the energy of the passing particle. Some way of recognizing different particles and measuring their energies had to be found.

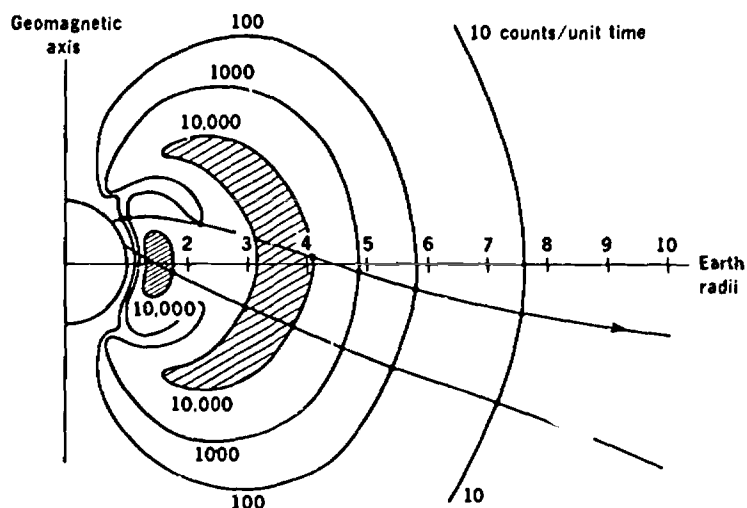

Figure 17 Van Allen's famous map of the radiation belts derived from the GM tubes carried by Explorer 4 and Pioneer 3. The contours indicate regions of equal counting rates.

Sputnik 3 and Explorer 4 were the first satellites to carry scintillator detectors, which yield light pulses proportional to the energy deposited within the detector. Additional energy information was gained from these satellites by surrounding the radiation detectors with different thicknesses of shielding material. Since a piece of shielding material (say, aluminum) attenuates a flux of protons to a greater extent than it does a flux of electrons, a measure of particle discrimination was established.

Despite the launching of dozens of satellites carrying a great variety of radiation detectors during the early years of the Space Age, the detailed mapping of the Van Allen Belts proceeded slowly. Not only did the constituent electrons and protons vary over wide energy ranges, but the belt populations were continuously reshuffled by new inputs from the sun. In other words, the lines on the maps changed

with the solar cycle and with the onset of solar storms, which seem to inject particles into the belts despite the "forbidden" nature of this process. To make matters even more difficult, the detonations of nuclear weapons at high altitudes grossly distorted the belts. Modern maps of the belts always factor in the solar cycle.

Continued mapping of the Van Allen Belts has made it clear that the two belts shown in early maps (Figure 17) really merge into one vast earth-centered doughnut of trapped protons and electrons. Now that the electrons and protons and their energies have been sorted out by more refined instruments, two zones of high-energy particles have been identified: An *inner zone* of high-energy protons and an *outer zone* of high-energy electrons. In between is a *slot* where trapped particles with relatively low energies abound (Figure 18). The two zones (no longer called "belts") are drawn on a basis of energy rather than numbers of particles.

Life Histories — Birth vs. Death

Like people, occupants of the radiation belts are born, live a while in a crazy, oscillating world, and then die—in the sense that they finally escape their magnetic trap.

The population of the inner zone of high-energy protons is relatively stable in time, whereas the high-energy electron flux in the outer zone may increase a thousandfold soon after a solar flare is seen on the sun. Therefore two different birth processes exist. Scientists generally agree that many of the inner-zone protons are created by decaying albedo neutrons. This hypothesis, however, does not explain all observed details and must be regarded as only a partial explanation. The present explanation of the origin of the outer-zone electrons is even less satisfactory. The definite correlation with solar flares leads one to expect that these electrons come from the sun, but the solar-flare particles themselves are not nearly energetic enough. Furthermore, no one has satisfactorily explained how flare particles can enter the belt region and be trapped—remember the trapped zones are "forbidden" according to Störmer's theory. Quite obviously, the birth processes require much more research before they can be fully explained.

Death, on the other hand, is easier to understand. Collisions of electrons and protons with atoms in the polar atmosphere are the most likely cause. Electrical neutralization of a belt particle by collision with such atoms manifestly opens the door because the magnetic field can no longer contain it. Collisions can also scatter particles out of the belt by changing their directions of travel and their energies. Just as light is not reflected well from a dirty mirror, belt particles do not always bounce back from the "spongy" atmosphere.

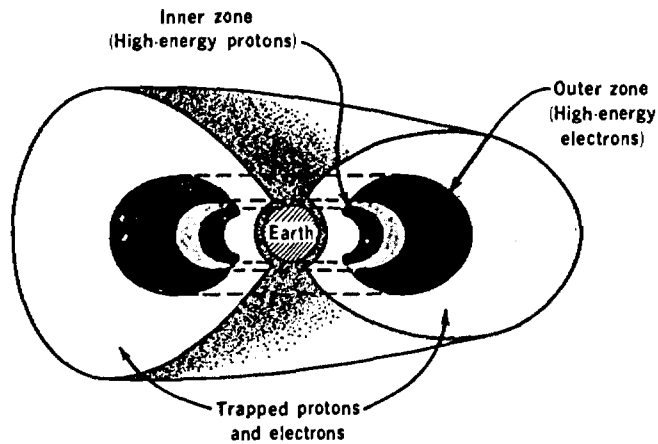

Figure 18 Section through the earth's geomagnetic axis showing the present view of the structure of the zones of trapped radiation. These zones vary in shape and intensity with the solar cycle. The impact of the solar wind flattens the "doughnut" on the sunward side. (See Figure 22.).

Between birth and death, a trapped particle zips back and forth along spiral paths between geomagnetic poles; in addition, it drifts westward or eastward around the earth. This rather nervous and complex life is best understood by considering the three separate components of motion: (1) Spiraling along the magnetic lines of force, (2) Bouncing back and forth between polar "magnetic mirrors", and (3) East or west drift due to distortions in the earth's field (Figure 19).

The earth's magnetic field is usually pictured in terms of lines of force diverging from one pole and converging on the other (Figure 5). A charged particle injected into this field perpendicular to a line of force goes around it in a circle with a radius directly proportional to the particle's mass and velocity and inversely proportional to the strength of the magnetic field. Protons are 1840 times more massive than electrons, and, all other things being equal, travel in circles 1840 times larger and in the opposite direction because of their opposite charge. All particles describe tighter circles near the geomagnetic poles where the magnetic field is stronger, as indicated by the converging lines of force. Two-dimensional circles are turned into three-dimensional spirals (or helices) when the particles also possess a component of velocity that is parallel to the lines of force, which they usually do. A charged particle starting at the geomag-

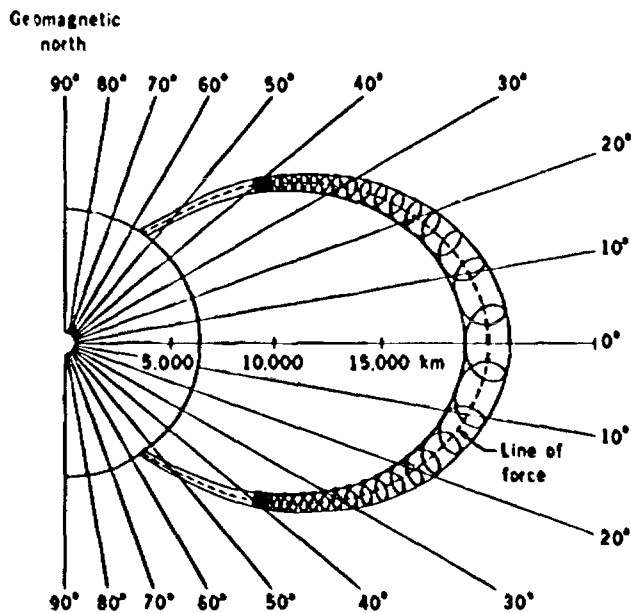

Figure 19 Charged particles trapped in the radiation zones spiral back and forth from pole to pole along magnetic lines of force. Superimposed upon the spiral they bounce in an east or west drift around the earth, the direction depending upon the sign of the trapped particle. Protons drift east to west and electrons west to east.

netic equator thus spirals poleward around its private line of force, tightening its spiral as it goes. The reverse is true on the return trip.

Why don't the particles just keep on going until they strike the atmosphere and are absorbed? A few do, of course, but a particle may be turned around (reflected) before it hits the atmosphere if its velocity parallel to the magnetic line of force is high enough relative to its total velocity. For these particles, the earth's converging field acts like a *magnetic mirror* that reflects the particles from pole to pole.* Calculations indicate that a trapped proton in the inner zone may spiral from pole to pole once every few seconds over a life-span as long as several hundred years. Trapped protons obviously lead active lives.

The third and final component of particle motion is the east-to-west drift of protons and west-to-east drift of electrons that is added to the north-to-south spirals. This longitudinal drift is caused by the fact that the strength of the earth's magnetic field varies with height and gives the spiraling-oscillating particles a push, eastward or westward, depending upon their electrical charge. The time required for a complete revolution of the earth varies strongly with particle energy, and may be measured in minutes and even hours. The east-west drift of charged particles constitutes a net flow of electrical charge; in other words, an equatorial *ring current*. Measurements show, however, that the currents are not nearly strong enough to cause magnetic storms on the earth's surface.

The Argus and Starfish Explosions

When nature presents us with complex phenomena, such as earthquakes and invisible radiation belts, better insight can be obtained by nudging nature a bit. Now in geophysics, a nudge to nature is a colossal explosion to us—m

*Artificial magnetic mirrors are often employed in thermonuclear power experiments to create *magnetic bottles* that can confine ionized gases (plasmas) at temperatures of millions of degrees. See *Controlled Nuclear Fusion*, a companion booklet in this series.

specifically, a nuclear explosion. A nuclear detonation in the vicinity of the radiation belts injects immense numbers of high-energy charged particles—primarily electrons—into the trapped region. The time, altitude, and size of the explosion can be controlled so that science can benefit in three ways: (1) The observation of artificial auroras; (2) The mapping of the trapped regions by watching how they fill up with artificially produced particles; and (3) The study of residence times for the new particles. One might say that the artificially generated charged particles can be "followed", after the fashion of radioactive tracers, and thus highlight the workings of the Van Allen Belts.

The United States has exploded six nuclear bombs at high altitudes, and we know of at least three similar Russian explosions (see Table). Although a great deal of new scientific knowledge evolved from these detonations, science was not the moving force behind all of them. It turns out that intense shells of charged particles at high altitudes can interfere with communications and radar tracking of intercontinental ballistic missiles.*

Summary of Nuclear Explosions at High Altitudes

Code Name	TNT Equivalent	Altitude	Date	Location
Teak	?	76 km	Aug. 1, 1958	Johnston I.
Orange	?	44 km	Aug. 12, 1958	Johnston I.
Argus 1	1-2 kilotons	480 km	Aug. 27, 1958	38°S, 12°W*
Argus 2	1-2 kilotons	480 km	Aug. 30, 1958	50°S, 8°W*
Argus 3	1-2 kilotons	480 km	Sept. 6, 1958	50°S, 10°W*
Starfish	1.4 megatons	400 km	July 9, 1962	Johnston I.
USSR 1	?	400 km	Oct. 22, 1962	?
USSR 2	?	400 km	Oct. 28, 1962	?
USSR 3	?	400 km	Nov. 1, 1962	?

*From the Rocket Launching Ship *Norton Sound* (Figure 19).

The Teak and Orange explosions were at such low altitudes that the artificial radiation belts they created lasted only a few days. Within a second or less after these explo-

*On October 10, 1967, the United States and Russia signed a treaty agreeing to do no more nuclear testing in space. Tests in the atmosphere and underwater, and in Antarctica, are now also prohibited to signatory nations (including the U. S. and Russia) by previous treaties.

sions, bright artificial auroras could be seen in the vicinity of the detonations. About a minute later auroras were observed 2000 miles away at 14°S over the Samoan Islands, where the earth's magnetic lines of force reach down into the atmosphere.

The Argus series of explosions, later in August 1958, had been suggested in late 1957 by Nicholas Christofilos. An objective of these explosions was to see if electron trapping actually occurs. By the time the experiment was ready, however, Van Allen had already discovered the natural radiation belts. Nevertheless, the Argus shots were scientifically valuable because they were high enough to create well-defined artificial radiation belts about 100 km (60 miles) thick between 1.7 and 2.2 earth radii above the earth's surface. Artificial auroras were also seen in both hemispheres near the poles after these detonations. The Explorer-4 satellite, carrying GM tubes and scintillator detectors, monitored these belts during the several weeks that they persisted (Figure 20).

Although the artificial radiation belts intrigued many scientists, others deplored man's contamination and distortion of a natural phenomenon. They feared that some valuable natural conditions might be inundated forever by weapon debris.

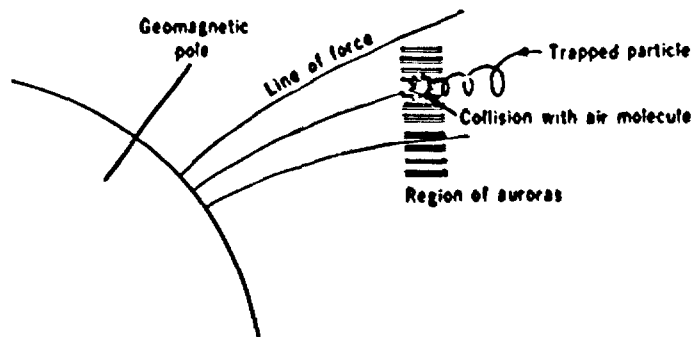

Figure 20 When a trapped particle penetrates the upper atmosphere and collides with an atmospheric molecule, the collision releases the particle from the magnetic trap, and the particle's energy may be converted into auroral light.

The Starfish explosion was the largest set off by the United States at high altitudes. It upset many scientists even more. Brilliant auroras appeared almost immediately over the rocket launch site and New Zealand, 3000 miles away. The increased ionization in the ionosphere disrupted radio communication over large areas for several days. The artificial radiation belt was so intense that the solar cells providing power for three U. S. satellites were severely damaged. The radiation from the man-made protons returned to previous levels within a few months, but the electron belt is disappearing slowly and may persist until the early 1970s. Although the Starfish effects were stronger and longer lasting than initially expected, these effects are valuable in themselves because they have given us data to correct our pre-Starfish theories. But the thought lingers in some minds that nature has been defiled.

BEYOND THE GREAT RADIATION BELTS

Beyond the Van Allen Belts stands the third and last breakwater sheltering the earth from much that transpires in interplanetary space. As with cosmic rays and the radiation belts, a few suggestive observations and surmises preceded the actual discovery of the magnetopause and the current of solar wind that breaks against it.

Before there were satellites and space probes, the only hint that a steady solar wind sweeps the entire solar system came from the observation that comet tails almost always point away from the sun, regardless of the comet's direction of travel. Radiation pressure was first enlisted to explain this strange behavior but this theory was later shown to be inadequate. In the early 1950s, the German physicist, Ludwig F. Biermann, showed that a steady current of high-speed protons and electrons boiling off the sun could account for the blowing comet tails. Biermann's hypothesis was supported in 1958 by Eugene N. Parker, a young physicist at the University of Chicago. Parker showed theoretically that some electrons and protons in the sun's million-degree corona were so hot (that is, had such a high speed) that they would escape the sun's gravitational field and fill interplanetary space with a steady "wind" consisting of several protons per cubic centimeter and blowing at several hundred miles per second. (Although this speed seems high, the particle energies are relatively low for space radiation; for example, a proton travelling at 500 km per second has an energy of only 1300 electron volts compared with the millions of electron volts possessed by trapped particles.) The theoretical stage was thus set for the discovery of this third, very low-energy component of space radiation.

Still another hint—though not a very conclusive one—came from the observation in 1937 by Scott E. Forbush, an American physicist, that the intensity of primary cosmic rays decreased soon after the eruption of a solar flare. The *Forbush Effect* could be due either to the flare material itself reaching out toward the earth or to fluctuations in the earth's magnetic field caused by the flare. Something associated with solar flares was shielding the earth from primary cosmic rays.

It is important to note that just about all cosmic rays were thought to have their origins well out in our galaxy, beyond the solar system, until the great solar flare of February 23, 1956. On that date a huge flare appeared on the sun's face, and in a few minutes cosmic-ray detectors all over the earth began registering many times their normal count of cosmic rays. In the preceding 20 years only four cases of solar cosmic rays had been definitely recorded. The 1956 event convinced everyone that the sun indeed did generate cosmic rays—in copious amounts at times. This discovery underscored the intimacy of the sun-earth relationship, despite the distance of 93,000,000 miles separating the two bodies.

This modest groundwork did not adequately prepare the scientific community for the rather bizarre pictures drawn by the Pioneer deep-space probes and satellites, such as Explorers 18 and 21, which had long eccentric orbits that took them tens of thousands of miles into space.

From theory, one would expect that the earth's magnetic field strength would decrease with the cube of the distance from the earth. The first magnetometer-carrying probes and satellites found these expectations fulfilled, up to a point. Beyond a distance of about eight earth radii, however, the magnetic field showed extreme disorder and then a sudden drop to the level of the solar magnetic field. Subsequent mapping confirmed that the earth was surrounded by a rather sharp transition region, with the earth's field bottled up inside and the sun's field excluded outside (Figure 21).

This transition region is called the *magnetopause*, and the volume inside it, containing the earth's field, is the *magnetosphere*. It turned out that the magnetosphere was far from spherical; it was in reality shaped like a teardrop with a long "wake" streaming out behind it like an invisible comet tail. What causes this streamlined shape? The satellite-borne detectors of low-energy protons and electrons (*plasma probes*) that penetrated the magnetopause discovered the solar wind that had been hypothesized by Biermann and Parker. Sunward, this solar wind was ramming up against the earth's magnetic field and compressing it into a shock front, flowing around it, and creating the teardrop shape one expects to see as fluid rushes past a spherical obstruction. Leeward of the earth, the earth's magnetic

lines of force stretched out for hundreds of thousands of miles forming the earth's "tail".

The earth thus presents a strange apparition to a viewer seeing it through magnetometers and particle detectors. As our planet swings about its orbit, it is sheltered from the solar wind by an elongated magnetic hull that always presents a blunt prow toward the sun.

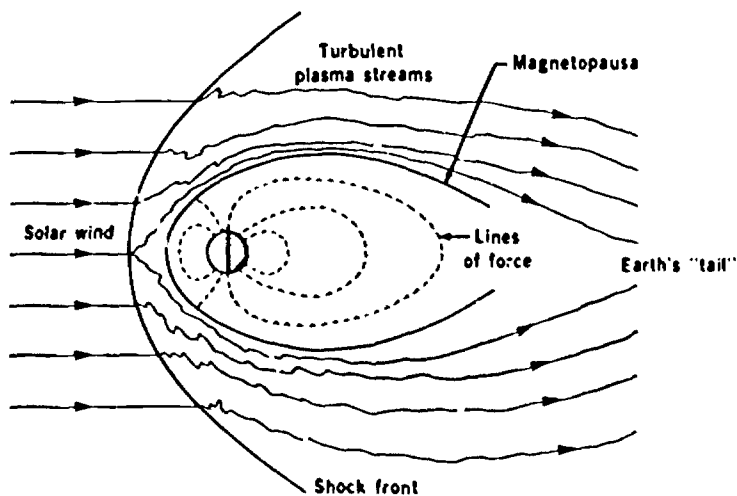

Figure 21 Conceptual sketch showing the flow of solar plasma around the earth's magnetopause. The earth's magnetic field is distorted into a teardrop shape by the force of the solar wind. The zones of trapped radiation shown in Figure 18 are confined within the magnetopause. (Compare with Figure 1.)

It is a rare sea that is devoid of storms. The interplanetary sea is no exception. The sun, always restless, creates interplanetary storms when a center of activity on its surface, say, a sunspot, spews forth a cloud of plasma at jet-plane velocity (600 to 1200 mph). The plasma sweeps along the sun's outwardly spiraling lines of force toward the planets, piling up a shock front consisting of the slower travelling solar wind. The most popular view of this plasma cloud presents it as a "tongue" that carries part of the sun's magnetic field along with it, as electrical conductors such as plasmas are wont to do (Figure 22). The tongue, in this

view, is an elongated magnetic bottle confining the hot plasma ejected by the sun.

When the onrushing plasma tongue smashes into the earth's magnetopause, the turbulence causes a series of magnetic storms. Brilliant auroras may also be seen,

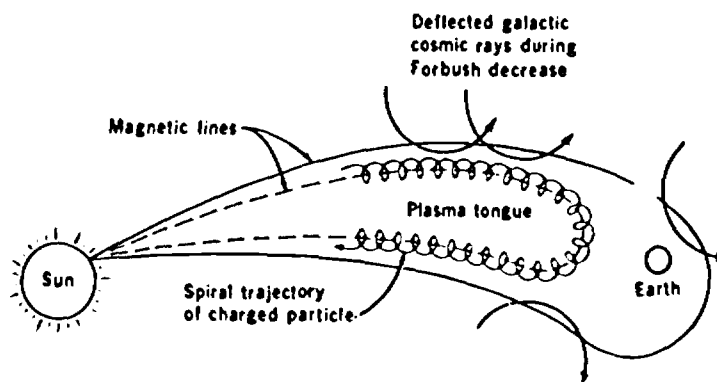

Figure 22 Hypothetical plasma tongue engulfing the earth and causing a Forbush decrease in the intensity of primary cosmic rays.

possibly because the storm helps precipitate electrons from the Van Allen Belts, though this is only surmise at present. The solar plasma tongue easily engulfs the entire earth and shields it with its magnetic bottle. The Forbush decrease in primary cosmic-ray intensity occurs during this brief protective period.

Plasma tongues and the solar wind are, of course, not things we can see or feel unaided by instruments. The 1962 Venus probe, Mariner 2, showed that the plasma in a solar tongue has a density of only 10 to 20 protons per cubic centimeter—a degree of rarefaction unobtainable even in our best vacuum chambers on earth. Like all other space radiation, solar plasma is sparse and invisible, though perhaps not innocuous.

IS SPACE TRAVEL SAFE?

Persons who already felt that space travel could not succeed found satisfaction in the discovery of the Van Allen Belts and the solar-storm radiation, for surely, they reasoned, these would be lethal to all who ventured beyond the protecting breakwaters of the atmosphere, ionosphere, and magnetopause. But the many astronauts who have returned safely from orbit since 1961 show how inflated these fears were. Space radiation isn't harmless, but astronaut protection is really an engineering problem, with reasonable, available solutions.

To begin with, *complete* protection from space radiation is impossible, even for people on earth. The human race has survived primary cosmic rays for millions of years without artificial protection and without disastrous effects. It is a question of how much *additional* exposure can be absorbed, for space radiation is little different in its effects from that emitted by dental and medical X-ray machines.

There are three important sources of potentially dangerous space radiation: the Van Allen Belts, galactic cosmic rays, and the intense bursts of solar cosmic rays emitted during solar flares. The solar wind and the plasma within the solar-plasma tongues constitute no threat to humans in space, because the protons and electrons are too weak to penetrate spaceship hulls or even spacesuits.

American and Russian astronauts usually orbit well below the intense inner Van Allen Belt. Even though they are above the atmospheric shield, the additional primary cosmic rays and the few trapped particles on the fringes of the Van Allen Belts amount to only a few millirads* per day, much less than the exposure permitted workers in atomic energy installations. Spacecraft could orbit indefinitely beneath the Van Allen Belts without fear of overexposing the crews.

The use of massive shields to protect astronauts against primary cosmic radiation is hardly needed. Even extremely thick slabs of heavy metals would hardly diminish the flux of

*The rad is the basic unit of absorbed radiation and equals 100 ergs per gram of absorbing material; a millirad is one thousandth of a rad.



SPACE RESEARCH VEHICLES

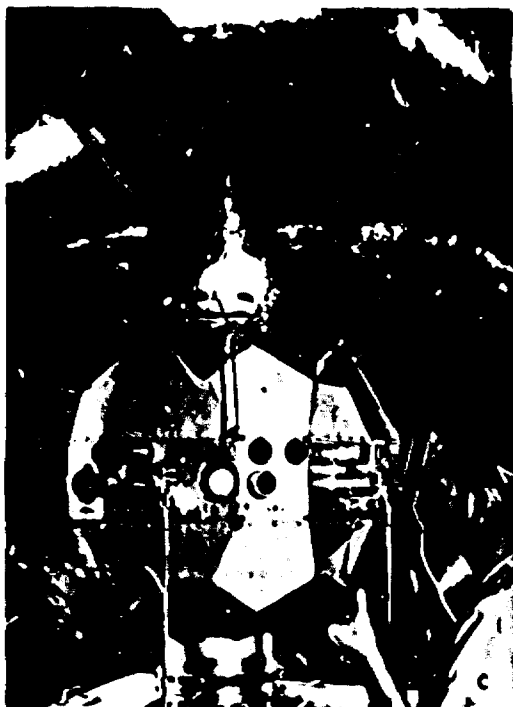

(A) An Astrobee 1500, a 5½-ton solid rocket capable of carrying scientific instruments over 1000 miles, is checked out prior to launching from NASA's Wallops Island Station on the Virginia coast. (B) A Stratoscope II balloon is inflated with 14,500 pounds of helium gas. Balloons of this type can ascend to 80,000 feet and more with cargoes of instruments. (C) The polyhedral satellite is one of the Injun series developed by the State University of Iowa and launched by NASA. Instrument ports are around the satellite's equator. A number of Injuns are helped map the Van Allen radiation belts. (D) Pioneer 6, a deep-space probe now in orbit around the sun. From such an orbit it can radio back information about the solar wind and plasma "tongues". Pioneer 6 is basically a cylinder with thousands of solar cells covering its curved surface. The perforated tube on top is a telemetry antenna.

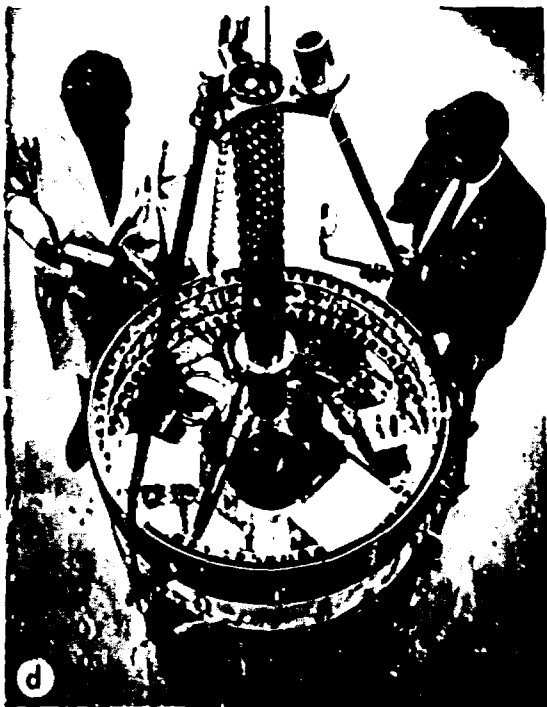
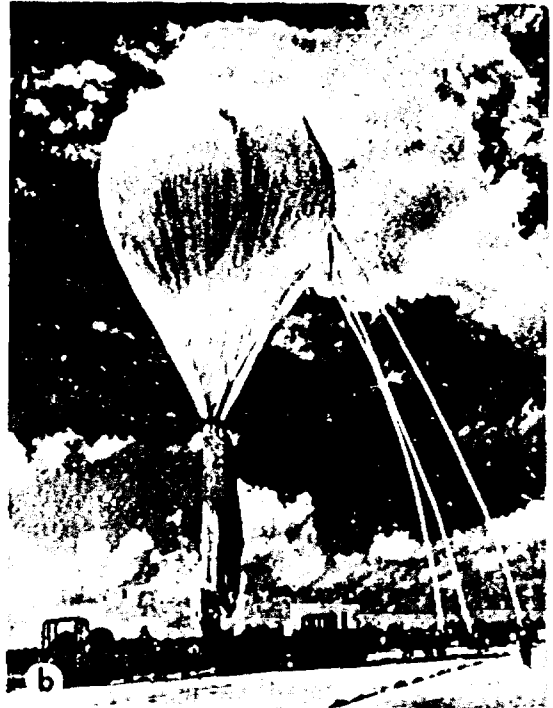

primary cosmic rays; besides, in penetrating such dense matter a few high-energy protons would create avalanches of secondary cosmic rays that could be more dangerous than the primary ones that caused them. Fortunately, the bulk of the primary cosmic rays are protons and helium nuclei that pose little danger in small quantities. However, if one of the larger nuclei, such as iron, which make up 2 to 3% of the primary cosmic rays, were to be absorbed and release its energy in a vital spot, like the brain, enough cells *might* be destroyed to incapacitate an astronaut. The probability of this happening is considered so minute that space mission planners ignore it.

The most intense radiation levels in the Van Allen Belts are high enough to kill an unprotected man within a few days. The easiest solution to the problem this poses is to program orbital flights so that they avoid the Van Allen Belts altogether, as they have in the past. In practice, this means that the satellites must avoid the regions where the belts bend down toward the atmosphere and, in addition, remain below an altitude of roughly 500 miles. Spacecraft aimed at the moon and the planets can ascend right through the belts without danger, however, because the time of their transit of the belts will be measured only in minutes—far too short to cause important biological damage.

The solar cosmic rays emitted during solar flares are considered the most dangerous kind of space radiation. Perhaps a half dozen dangerous flares occur each year, more during the peaks of the 11-year sunspot cycle. Because a large flare might increase cosmic-ray intensity in the vicinity of the earth by a hundred times and maintain high levels for several days, exposed astronauts might receive lethal doses before they could reach the haven of our magnetosphere and atmosphere.

Space flight beyond the magnetopause can be made safe in two ways: spacecraft shielding and timing the launches to occur during a quiet period on the sun.

Spacecraft shielding is the more direct and sure approach. No one envisions mounting thick slabs of lead aboard the spacecraft. As a matter of fact, the spacecraft structure, the electronic equipment, and water supplies already constitute shielding by virtue of their mass. By proper placement of

such items, the astronauts can be protected without unduly adding to the weight of the spacecraft. The succession of solar storms in July 1959 (apparently the largest ever recorded) would have given an astronaut protected within an Apollo spacecraft a skin dose of about 150 rads and a dose of about 15 rads to the blood-forming tissues. These are rather large doses, but they are neither lethal nor even immediately incapacitating. The radiation hazard from a large solar flare, it appears, can be made far less severe than the other probable hazards of a voyage to the moon.

The word "probable" in the last sentence must be emphasized, because the chances are that the Apollo mission round trip to the moon will be completed without any serious solar flares erupting from the sun's surface. Nevertheless, reduction of hazards is always important, so scientists have been looking for ways to predict the onset of a solar flare. If a flare seems imminent, the mission could be delayed or even recalled, if it is not too far away. Just as earthquakes announce themselves beforehand with minor noise and tremors, solar flares seem to presage their eruption by subtle visible changes in the solar centers of activity. No reliable forecasting system has yet been devised for solar flares, but one may come in the near future.

Insurance companies naturally hesitate to write policies for astronauts (although it was done for the first seven). However the odds and premiums are calculated, space radiation cannot weigh heavily as a hazard compared to the threat of retrorocket failure, complete loss of attitude control, or similar lethal equipment malfunctions. Space radiation, in short, presents hazards no more dangerous than dental X rays, providing the astronaut travels during the right season and does not loiter in the Van Allen Belts.

SUGGESTED REFERENCES

Popular Articles and Books

- The Sun, Herbert Friedman, *National Geographic Magazine*, 128: 713 (November 1965).
- Man-Made Radiation Belts, Wilmot N. Hess, *International Science and Technology*, 40 (September 1963).
- Electrons (+ and -), Protons, Photons, Neutrons, Mesotrons, and Cosmic Rays*, Robert A. Millikan. University of Chicago Press, Chicago 60637, 1947, 492 pp., out-of-print classic available in many libraries.
- Radiation Belts, Brian J. O'Brien, *Scientific American*, 207: 84 (May 1963).
- Cosmic Rays*, Bruno Rossi, McGraw-Hill Book Company, Inc., New York 10036, 1964, 268 pp., \$7.00 (hardback); \$2.95 (paperback).
- The Aurglow, Robert A. Young, *Scientific American*, 214: 3 (March 1966).
- Antimatter and Cosmology, Hannes Alfvén, *Scientific American*, 216: 4 (April 1967).
- Magnetic Fields on the Quiet Sun, William C. Livingston, *Scientific American*, 215: 5 (November 1966).
- The Luminescence of the Moon, Zdeněk Kopel, *Scientific American*, 215: 5 (May 1965).
- The Origin of Cosmic Rays, Geoffrey Burbidge, *Scientific American*, 215: 2 (August 1966).
- Neutrinos from the Atmosphere and Beyond, Frederick Reines and J. P. F. Seilschop, *Scientific American*, 214: 2 (February 1966).
- The Aurora. Syun-Ichi Akasofu, *Scientific American*, 213: 6 (December 1965).
- The Magnetic Field of the Galaxy, Glenn L. Berge and George A. Seelstad, *Scientific American*. 212: 6 (June 1965).
- The Magnetosphere, Lawrence J. Cahill, Jr., *Scientific American*, 212: 3 (March 1965).

More Difficult Articles and Books

- Science in Space*, Lloyd V. Berkner and Hugh Odishaw (Eds.), McGraw-Hill Book Company, Inc., New York 10036, 1961, 458 pp., \$9.00 (hardback); \$3.95 (paperback). (Out of print but available through libraries.)
- The Argus Experiment, Nicholas Christofilos, *Journal of Geophysical Research*, 64: 869 (1959).
- Radiation Hazards in Space, D. L. Dye and M. Wilkinson, *Science*, 147: 19 (January 1, 1965).
- Sourcebook on the Space Sciences*, Samuel Glasstone, D. Van Nostrand, Company, Inc., Princeton, New Jersey 08541, 1965, 937 pp., \$7.55.
- Introduction to Space Science*, Wilmot N. Hess (Ed.), Gordon and Breach Science Publishers, Inc., New York 10011, 1965, 934 pp., \$29.75.
- Space Physics*, Donald P. Le Galley and Alan Rosen (Eds.), John Wiley & Sons, Inc., New York 10016, 1964, 752 pp., \$25.00.

- Space Science*, Donald P. Le Galley (Ed.), John Wiley & Sons, Inc., New York 10016, 1963, 668 pp., \$17.50.
- The Radiation Belts, Natural and Artificial, Carl C. McIlwain, *Science*, 142: 355 (October 18, 1963).
- The Earth's Radiation Belts, R. Stephen White, *Physics Today*, 19: 25 (October 1966).
- Cosmic Rays, Solar Particles, and Space Research*, Bernard Peters (Ed.), Academic Press, Inc., New York 10003, 1964, 418 pp., \$16.00.
- Scientific Uses of Earth Satellites*, (2nd revised edition), James A. Van Allen, University of Michigan Press, Ann Arbor, Michigan 48106, 1958, 316 pp., \$10.00.
- Significant Advances in Particles and Fields* (NASA SP-97), Superintendent of Documents, U. S. Government Printing Office, Washington, D. C. 20402, 1966, \$0.50.
- Nuclear Physics and the Fundamental Particles*, Harry A. Heckman and Paul W. Starring, Holt, Rinehart and Winston, Inc., New York 10017, 1963, 410 pp., \$2.60. (Out of print but available through libraries.)

CREDITS	
Cover courtesy Defence Research Board of Canada	
Figure	
1	National Aeronautics and Space Administration (NASA)
7	Vic Hessler, University of Alaska
10	U. S. Naval Research Laboratory
12	Wernher von Braun
13 & 14	State University of Iowa
16	NASA
Pages	
52 & 53	NASA

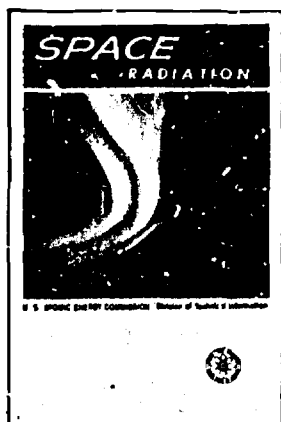

ABOUT THE COVER

Radiation in space is clearly revealed in the auroras, or "Northern Lights", caused by streams of charged particles entering the earth's magnetic field. The spectacular auroral display on the cover was photographed at Churchill, Manitoba, and is published through the courtesy of Dr. William Petrie, Deputy Chairman (Scientific) of the Defence Research Board of Canada.

ABOUT THE AUTHOR

WILLIAM R. CORLISS is an atomic energy consultant and writer with 12 years of industrial experience including service as Director of Advanced Programs for the Martin Company's Nuclear Division. Mr. Corliss has B.S. and M.S. Degrees in Physics from Rensselaer Polytechnic Institute and the University of Colorado, respectively. He has taught at those two institutions and at the University of Wisconsin. He is the author of *Propulsion Systems for Space Flight* (McGraw-Hill 1960), *Space Probes and Planetary Exploration* (Van Nostrand 1965), *Mysteries of the Universe* (Crowell 1967), *Scientific Satellites* (GPO 1967), and coauthor of *Radioisotope Power Generation* (Prentice-Hall 1964), as well as numerous articles and papers for technical journals and conferences. In this series he has written *Neutron Activator Analysis*, *Power Reactors in Small Packages*, *Direct Conversion of Energy*, *SNAP—Nuclear Reactor Power in Space*, *Computers*, *Nuclear Propulsion for Space*, and was coauthor of *Power from Radioisotopes*.



This booklet is one of the "Understanding the Atom" Series. Comments are invited on this booklet and others in the series; please send them to the Division of Technical Information, U. S. Atomic Energy Commission, Washington, D. C. 20545.

Published as part of the AEC's educational assistance program, the series includes these titles:

<i>Accelerators</i>	<i>Nuclear Propulsion for Space</i>
<i>Animals in Atomic Research</i>	<i>Nuclear Reactors</i>
<i>Atomic Fuel</i>	<i>Nuclear Terms, A Brief Glossary</i>
<i>Atomic Power Safety</i>	<i>Our Atomic World</i>
<i>Atoms at the Science Fair</i>	<i>Plowshare</i>
<i>Atoms in Agriculture</i>	<i>Plutonium</i>
<i>Atoms, Nature, and Man</i>	<i>Power from Radioisotopes</i>
<i>Careers in Atomic Energy</i>	<i>Power Reactors in Small Packages</i>
<i>Computers</i>	<i>Radioactive Wastes</i>
<i>Controlled Nuclear Fusion</i>	<i>Radioisotopes and Life Processes</i>
<i>Cryogenics, The Uncommon Cold</i>	<i>Radioisotopes in Industry</i>
<i>Direct Conversion of Energy</i>	<i>Radioisotopes in Medicine</i>
<i>Fallout From Nuclear Tests</i>	<i>Rare Earths</i>
<i>Food Preservation by Irradiation</i>	<i>Reading Resources in Atomic Energy</i>
<i>Genetic Effects of Radiation</i>	<i>Research Reactors</i>
<i>Index to the UAS Series</i>	<i>SNAP, Nuclear Space Reactors</i>
<i>Lasers</i>	<i>Sources of Nuclear Fuel</i>
<i>Microstructure of Matter</i>	<i>Synthetic Transuranium Elements</i>
<i>Neutron Activation Analysis</i>	<i>The Atom and the Ocean</i>
<i>Nondestructive Testing</i>	<i>The Chemistry of the Noble Gases</i>
<i>Nuclear Clocks</i>	<i>The First Reactor</i>
<i>Nuclear Energy for Desalting</i>	<i>Whole Body Counters</i>
<i>Nuclear Power and Merchant Shipping</i>	<i>Your Body and Radiation</i>
<i>Nuclear Power Plants</i>	

A single copy of any one booklet, or of no more than three different booklets, may be obtained free by writing to:

USAEC, P. O. BOX 62, OAK RIDGE, TENNESSEE 37830

Complete sets of the series are available to school and public librarians, and to teachers who can make them available for reference or for use by groups. Requests should be made on school or library letterhead and indicate the proposed use.

Students and teachers who need other material on specific aspects of nuclear science, or references to other reading material, may also write to the Oak Ridge address. Requests should state the topic of interest exactly, and the use intended.

In all requests, include "Zip Code" in return address.

Printed in the United States of America

USAEC Division of Technical Information Extension, Oak Ridge, Tennessee

June 1968