

# An Exploration of Some Universal Ordering Principles

Michael T. Hyson<sup>†</sup>, Elizabeth A. Rauscher<sup>‡</sup>

<sup>†</sup>*The Resonance Project Foundation, PO Box 764, Holualoa, Hawai'i 96725 and  
Sirius Institute, PO Box 1645, Pahoa, Hawai'i 96778, (808) 896-8518  
hyson@planetpuna.com*

<sup>‡</sup>*Tecnic Research Laboratory, 3500 S. Tomahawk Rd., Bldg #188, Apache  
Junction, Arizona 85219, (480) 982-2285, bvr1001@msn.com*

**Abstract:** Observations suggest some patterns of universal order are inherent. These are indicated by energetic structures throughout the solar system reflecting tetrahedral geometry which, in part, lead us to postulate a vacuum geometry based on the tetrahedron and cuboctahedron. Patterns based on Phi (0.618...) are ubiquitous and correspond to similar patterns seen in biology and the form of expansion or contraction of the vector equilibrium. Several structures suggest double-torus flow patterns. We find self-similar structures at many scales suggesting the universe is fractal and may be self-organizing. We then briefly consider the role of biology and the nature of consciousness and show that incorporation of these concepts in physical modeling may lead to more profound understandings and open novel paths to unification of physics, chemistry, biology and consciousness.

**Keywords:** Universal patterns, double-torus, cuboctahedron, fractal, Phi

## 1. INTRODUCTION

Near the end of his life, Hamilton wrote to Tait: "*Could anything be simpler? ...you feel as well as think, that we are on a right track; and shall be thanked hereafter? Never mind when.*"

*"What we call empty space contains an immense background of energy, and that matter, as we know it is a small, quantized wavelike excitation on top of this background, rather like a tiny ripple on a vast sea." -- David Bohm, Wholeness and the Implicate Order (p. 242)*

This is an exploration of inherent universal ordering principles. In observing the universe around us we obtain clues to principles that help us determine its structure and functioning. Many of these clues involve geometric correlations observed in pulsars, planets, galaxies, and in dynamic weather systems like hurricanes. We examine some of these aspects herein and suggest they offer insight into the underlying vacuum structure and its dynamic flow patterns that may cause the structures we experience.

We find energetic structures throughout the solar system reflecting fundamental tetrahedral geometry and therefore postulate a vacuum organization based on tetrahedral geometry. To show that this geometry is fundamental and important, we point to some of the energetic events occurring across the solar system and examine the role of tetrahedral and cuboctahedron geometry to planetary storms and auroras.

Along with many others throughout history<sup>1</sup>, we find that Phi,  $\phi = \frac{1+\sqrt{5}}{2} = 1.6180339887\dots$  is a key in the description of growth, flow, and vortex structures and appears in many systems at all scales from galaxies, to hurricanes, to shells and plants, suggesting the universe is self-similar and, perhaps, fractal. One would like to understand “*Why Phi?*” We suggest a possible mechanism of how this ratio may arise from the transformations of the cuboctahedron.

We note that despite current theoretical attempts to build a description of the world starting from random processes, in fact, even a most basic appreciation demonstrates we are surrounded by coherently ordered structures at all scales. This was known from at least the time of Pythagoras and his followers. In this tradition, one based understanding on the apprehension of order, proportion, and harmony – thought to reflect underlying patterns of the universe. We demonstrate there is much evidence to commend this view. Science, physics, and philosophy lost much ground because of the suppression of the Pythagorean insights; perhaps it is now time that we revisit the attitude that the universe is orderly.

In the quest for unification, such considerations are crucial. In addition, in order to advance to a complete, unified picture of the universe, one must include and address the whole universe and therefore must go beyond the usual bounds of physics. That is, one must incorporate aspects of life and consciousness, usually reserved for biology or psychology into a unified model of reality. For much of the history of biology it was thought that life could be explained using classical models and ordinary chemistry. We now can begin to see the outlines of a more inclusive view in which quantum effects and the effects of vacuum interaction in biology must be considered. For example, the metabolism of food requires extraction of energy using electron transport chains in the mitochondria while photosynthesis involves splitting water using light in the chloroplast. These processes incorporate quantum processes that must be understood.

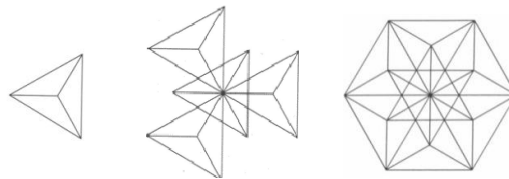
We also find that basic Platonic geometry relates to physics and symmetry breaking, as well as biology and the structure of DNA. Further, we examine structures in plasmas and dusty plasmas, and how they may relate to living structures. This is of great interest because some 98% of the universe we observe is plasma interacting with the vacuum. Even the structure and stability of DNA requires us to consider its interaction with the quantum vacuum. Thus we see that the paths deeply linking the realms of physics and biology are being determined.

In the realm of behavior, it was long thought from at least the time of Descartes, that living things are purely mechanical and their behavior could be derived from simple classical chemistry coupled with built-in functions like instincts coded in the genetics. Further, from the point of view of many biologists and psychologists such as B. F. Skinner, behavior could be explained by stimulus response and conditioned response learning; that's all. To summarize, it's been thought that we're basically "*living robots*". These attitudes carried over to "*modern*" psychology and neurophysiology such that our consciousness was considered a side effect of the activity of nerve cells – the "*Brain–Mind Identity Theory*".

As such, all thought about the nature of consciousness was curtailed by the idea that our experience of consciousness was merely an "*epi-phenomenon*" and to consider it to be anything else was to indulge in illusory concepts. While this view is still considered dominant there are signs of change. Some earlier work by Brian Josephson,<sup>2,3</sup> Elizabeth Rauscher, Russell Targ, Hal Putoff, Helmut Schmidt and others began this re-examination. More recently, explicit quantum models for consciousness have been advanced by Penrose and Hameroff and others. Lest one think that this area of investigation is simply a chimera, we consider advances in our understanding of Bell's theorem, and the connected nature of so-called "*entanglement*"<sup>4,5</sup> and "*non-locality*" and consciousness which we briefly discuss. It is hoped these insights will aid physical models and hasten the unification of physics, the inclusion of biology, and bring us an understanding of consciousness in the blooming of insights that will follow.

## 2. GEOMETRIC ASPECTS

Starting from a tetrahedral basic unit, we suggest that the vacuum structure can be usefully modeled as 64 tetrahedrons to form a cube that contains a cuboctahedral core.

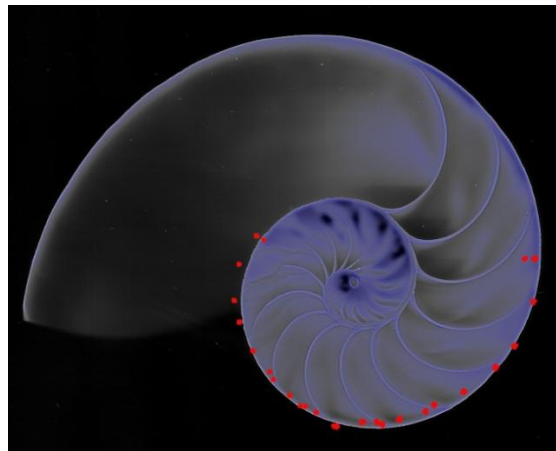


**Figure 1.** (Left) a tetrahedron; (Middle) Basis for the cuboctahedral "*vector equilibrium*" - the outer vertexes of 4 tetrahedra form the vertexes of a cuboctahedron; (right) a cuboctahedron

The basic structure of a cuboctahedron is 4 tetrahedrons meeting at a point. This creates 12 central vectors with the edges of equal length (Fig. 1). Connecting the points at the bases of the four tetrahedrons forms a cuboctahedron. The cuboctahedron is called the "*vector equilibrium*" from the equality of the 12 central vectors. This structure has natural oscillation modes that can transform it, for example, from the cuboctahedron to octahedron, and then on to a tetrahedron and triangle.

As a preliminary approach to this aspect, we measured the path of a vertex of one of the corners of a square face of a flexible cuboctahedron model (“*jitterbug*”)<sup>6</sup> as it was compressed and spiraled toward the shape of an octagon. The projection of this path on the x-y plane shows, to first approximation, a Phi curve or log-spiral curve which warrants further exploration (Fig. 2). We suggest this is a good model for some aspects of the *zitterbewegung* of the quantum foam and suggests a geometrical model for the origin of spin.<sup>7</sup>

The cuboctahedron also represents the twelve around one cubic close-packing of spheres. This is the same geometry as diamond, and appropriate considering a vacuum entity with at least  $10^{93} \text{ gr} / \text{cm}^3$  density. It is interesting to note many structures reflect aspects of the cuboctahedron, and/or the octahedron, starting from the observed octahedral arrays of galactic super-clusters<sup>8,9</sup> (Fig. 3). Significant phenomena are also located in regions of galaxies, stars and large gaseous planets near key angles of the cuboctahedron (Fig. 4 & 5).

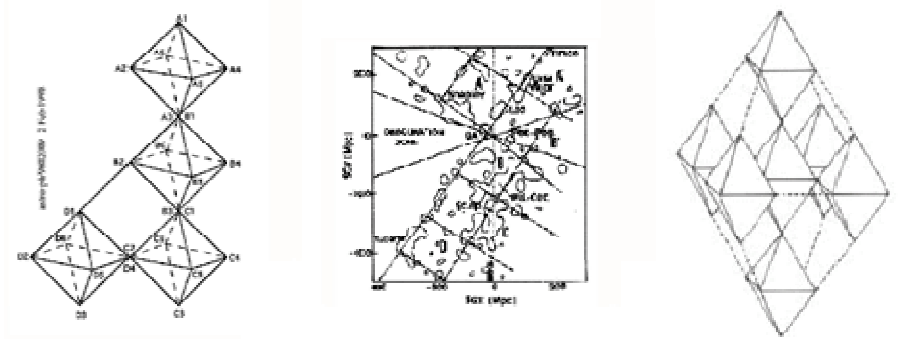


**Figure 2.** The path of a vertex of one corner of a square face of a flexible cuboctahedron model as it was compressed and spiraled toward the shape of an octagon projected on the x-y plane, showing a possible log-spiral curve.<sup>10</sup>

Starting from the equator of the cuboctahedron, the first significant angle is 19.47... degrees relative to the equator and corresponds to the center of a triangular face. Vorticular activity occurs at 19.47... deg. Lat. N. or S. throughout the solar system. Other significant angles are 54.73 degrees (choosing a vertex of a triangular face) and 70.52 degrees (Fig. 4a).

The cloud banding on Jupiter matches these angles closely (Fig. 4b). In Fig. 5, we overlaid images of Jupiter and Saturn with the cuboctahedron and show that auroral rings occur near 70.529... degrees (corresponding to the mid-top-triangle edge of the cuboctahedron).

A key tetrahedral angle is 19.47... degrees. For an inscribed tetrahedron in a sphere, with one point on the south pole, the other points will touch the sphere 120 deg. apart at 19.47... deg. N. latitude. This is a curious location. What structures do we find there? First, in Hawai'i, the top of the largest volcano on Earth, along the 19.47... latitude line, we find Mauna Loa and the Halema'u'ma'u crater; on the east and west side of Hawai'i we have Kealakekua Bay on the west and Cape Kumakahi on the east. This latitude line also lies across the main Pu'u'o'o vent and along a large fissure called the east rift zone. (Fig. 6a,b,c). On Mars, Olympus Mons (the largest shield volcano in the solar system) lies at 20 degrees N. latitude (Fig. 6d); we find similar structures near 19.47... degrees, like the Great Red Spot on Jupiter (Fig. 6e); the Great White Spot on Saturn (Fig. 6f); Neptune's Great White Spot (Fig. 6g); and Uranus' Great Dark Spot (Fig. 6h).



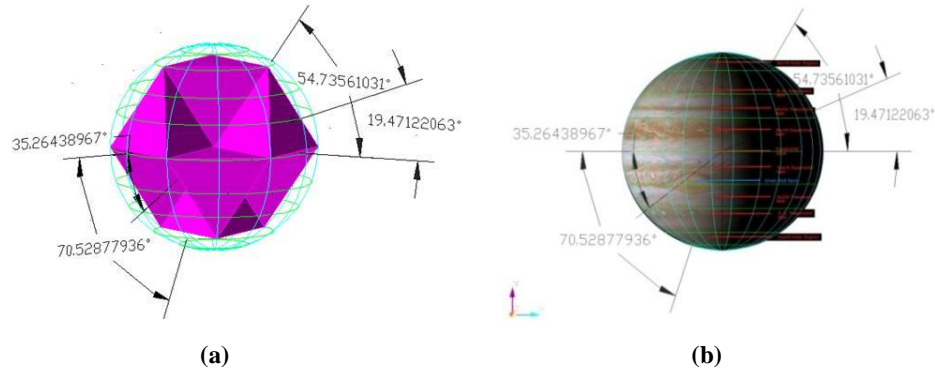
**Figure 3.** Large scale structures (Lower left & right) Recent data on the distribution of large scale structures, showing high levels of geometric coherency of gigantic octahedrons (from Battaner, 1988 [1] and Battaner and Florido, 1998 [2]). (Middle) Mapping of large scale structures showing an alignment passing through Draco, Ursa Major, Leo, Hercules and the Great Attractor, including a long chain of smaller clusters ending at Tucana.

All of these locations illustrate the importance of the tetrahedron and its cousins in the geometry of the universe. In passing, we note use of tetrahedral geometry was a major factor in the stability of electrostatic positioning devices for containerless processing.<sup>11</sup>

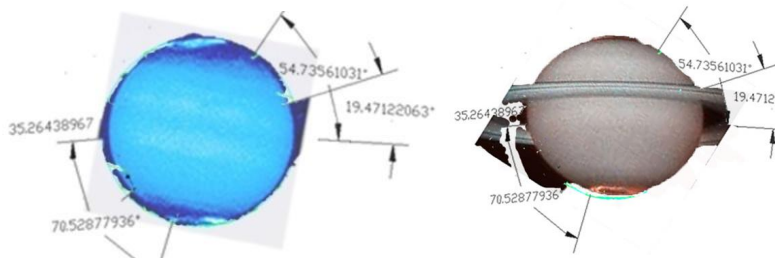
### 3. Double-Torus Flow Patterns

We observe that natural flow fields often occur in double-torus formations. There are examples, again, at many scales. One of the simplest demonstrations is the Falaco Soliton.<sup>12</sup> If one draws a flat circular plate through the water one will observe the formation of oppositely spinning *pairs* of vortices (Fig. 7a). In a fascinating series of papers, Keihn shows many correspondences between the Falaco solitons and cosmology. He offers that hydrodynamics and the Navier-Stokes equations become analytical (or nearly so) when only minimal surface solutions (related to bubble film structures) are considered as solutions. These minimal surface structures will retain

energy the longest; the Falaco solitons persist for minutes. We suggest that much more can be learned from fluidic models for the universe. For the moment, we concentrate on natural occurrences of double torus flow. We note the Falaco solitons formed in water are connected by a thin, spinning thread, analogous to a wormhole. Note the formal correspondence (at least) between this and photon-pair and particle-pair production, and wormholes. Basically, vortices form as pairs, a foundation of double-torus flows



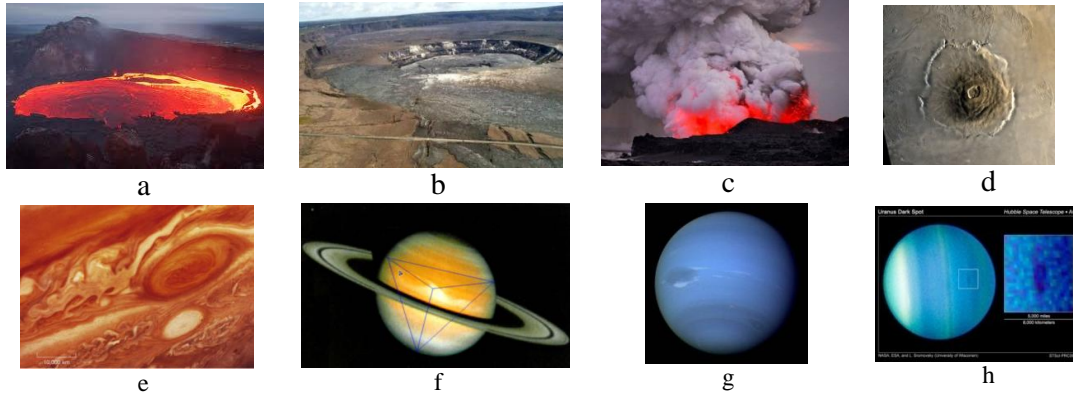
**Figure 4.** (a) Key angles formed by a cuboctahedron (b) Note the correspondence with atmospheric banding on Jupiter with cuboctahedral angles. [Red lines match JPL nomenclature] Note the Great Red Spot at 19.47 degrees S. latitude. (concept and figure by Andrew Cox<sup>13</sup>)



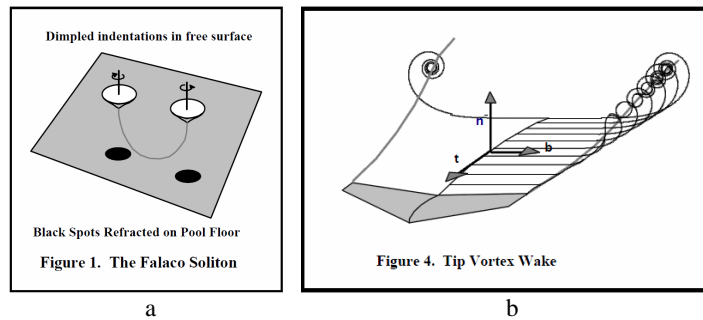
**Figure 5.** Auroras on Jupiter and Saturn align with the 70.528 degree position of the cuboctahedron

While toroidal models have been utilized for structures, such as black holes, these models often fall short of a comprehensive description of these phenomena. For example, some models have yet to address angular momentum conservation. Any model with just a single spinning torus must imply the existence of an equal and opposite flow *somewhere else* in the universe to satisfy conservation. The addition of a second torus stabilizes the spinning system and balances momentums. Double-torus dynamics satisfy conservation and the nilpotent condition<sup>14</sup> in a single system, having the advantages of balanced toroidal and poloidal flows summing to a total momentum of zero, making it very much self-contained. A single torus has, in contrast, a substantial gyroscopic moment; changing its plane of spin would require much energy.

A double-torus with balanced gyroscopic moments, would, for example, be easy to roll around.



**Figure 6.** Halema'u'ma'u Crater, Hawai'i at 19.47 deg. N. Lat.; (a) lava-filled; (b) empty (c) lava flowing into the sea from the Pu'u'u'o'o vent; (d) Olympus Mons at 20 deg. N. latitude; (e) Great Red Spot of Jupiter; (f) Saturn's Great White Spot; (g) Neptune's White Spot at 22 deg. S.; (h) The dark spot latitude of 27 degrees in Uranus' northern hemisphere.



**Figure 7.** The Falaco Soliton (Ref. 7) and tip vortices

Thus double-torus flow is stable. In confirmation, we present observational evidence that shows there double-torus flows in pulsars, nebulae, and galaxies, *inter alia*. We suggest that these flows reflect the active vacuum and are utilized in the Hamein-Rauscher  $U_4$  metric. The realms of the cuboctahedron and double-torus flow are linked as there is a topological relation between them through group theory.<sup>15</sup> All the above, is part of a basis for a self-similar (and perhaps fractal) structure of space-time underlying flows in galaxies, stars and planetary atmospheres.

The Egg Nebula Pulsar shows several features expected for a double-torus flow pattern. In particular, note the dark equatorial plane; this shows flows in each hemisphere are separated. We note that there are axial jet cones at the poles that have a  $\frac{1}{2}$  divergence angle of near the now familiar 19.47... degrees (Fig. 8a). Next we see a close-up of its equatorial plane (Fig. 8b). In Fig. 8c & d we see Eta Carina and the

Dipolar Planetary Nebula M 2-9 showing similar evidence of double-torus flows. Fig. 8e shows the Red Rectangle Nebula and in Fig. 8d we see a cross-section of its supposed structure. We note that this comprises a set of nested double-toroidal flows reminiscent of the wing tip vortices of Fig. 7b. We briefly note that all these toroidal flows are likely coiling according to a Phi curve.

We wish to point out a few other examples that suggest we are seeing the effects of the vacuum structure (perhaps of higher dimensions) reflected in physical structures. First, by what mechanism does one explain the clear hexagonal patterns at the poles of Jupiter (Fig. 9) and Saturn (Fig. 10)? We include these to show there are puzzles to be solved that are beyond our usual models. A further puzzle is to explain how an energetic vorticular “storm” can form at the south pole of Saturn; the poles are the coldest areas, so what is the energy source? This may relate to the puzzle that both Jupiter and Saturn radiate more energy than they receive from the Sun.

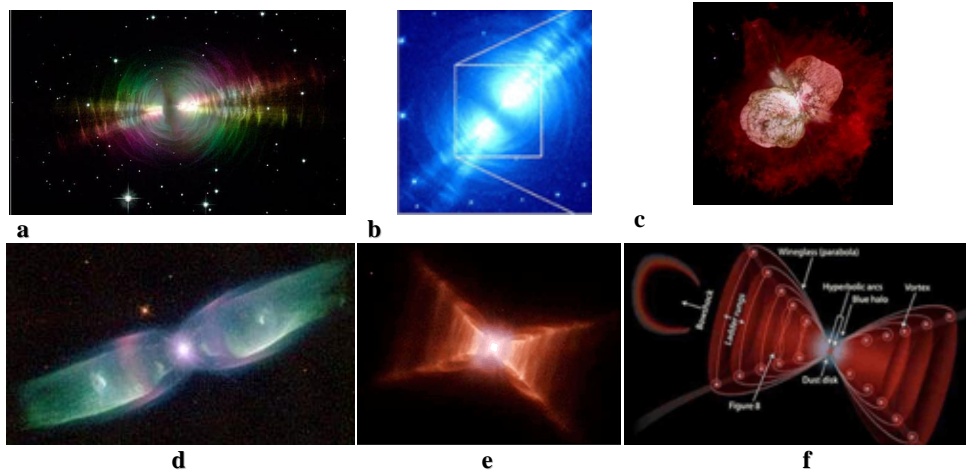
N. Hameiri’s investigations<sup>16,17,18,19</sup> suggest that organized matter, including galaxies, stars, and planets, may have singularities or singularity-like structures at their cores that are spinning rapidly. This leads to polarization of the local vacuum structure and to effects like frame-dragging that lead to observed structures. We can demonstrate a double-torus flow field for the stars that make up galaxies.

Envision a galaxy positioned between the tori of Fig. 11a with the galactic bulge at the center. Some stars follow a toroidal path, falling in at the poles, moving outward in the plane between the tori, and then become halo stars and travel inward at the polar regions. In a way perhaps analogous to V. Schaubberger’s pipe design,<sup>20</sup> (Fig. 11c) (which creates counter flows at the outer part of the pipe to organize the central flow) the outer-most halo stars move in retrograde orbits.<sup>21</sup> This may be related to MHD flows and Hartmann layers.<sup>22</sup> Relevant to the Phi nature of the galactic spiral shapes, it has recently been found that the tightness of the spiral of galactic arms is related to the central black hole mass.<sup>23</sup> We now go on to briefly review Phi structures in the universe.

#### 4. WHY PHI?

Phi is found in structures throughout nature. It is the only constant that allows growth or shrinkage while staying the same shape. It is seen in shells, plants, and throughout biology. Phi is the slowest converging of the continued fractions. Phi has the slowest damping, highest Q in phase space, and is like a geodesic curve for many systems. Phi may even be a master clock for our brain waves<sup>24</sup>, among other diverse aspects of this widely explored number.

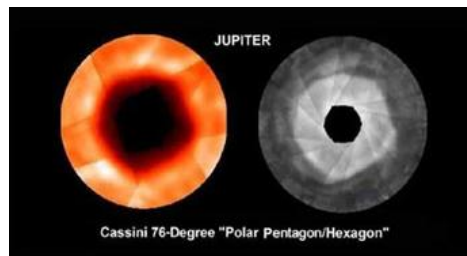




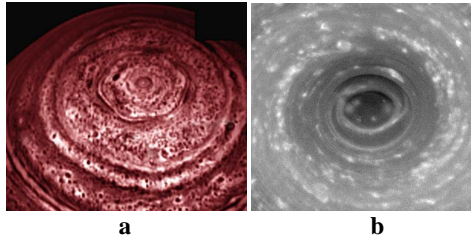
**Figure 8.** (a) Egg Nebula Pulsar; (b) Egg Nebula (close-up); (c) Eta Carina (Note equatorial plane); (d) Dipolar Planetary Nebula M 2-9 showing equatorial flow separations indicating double-torus flow structures; (e) The Red Rectangle Nebula with (f) multiple nested double-tori.

We saw above that the “breathing” of the “jitterbug” is likely along a Phi curve. If so, it relates to the curl of spacetime. Phi curves may form as a result of a balance of forces in vortex flows. We see this in phenomena at many scales as in Fig. 13; shells (Fig. 13a), water spouts; (Fig. 13b), hurricanes; (Fig. 13c), aircraft wing-tip vortices; (Fig. 13d), double helix filaments; (Fig. 13e) and spiral galaxies (Fig. 13f) All share a Phi nature suggesting it is fundamental. Fig. 14 shows several Phi relationships exist in the rings of Saturn and underlie the Cassini divisions and at finer scales as well, suggesting a Phi-related resonance in gravitational fields.

We have yet to use the above facts to order our theories and observations. Surely this most pervasive constant Phi needs to be considered. In preliminary investigations along these lines it appears that Phi can be incorporated easily both in topology<sup>25</sup>, and in the nilpotent rewrite system.<sup>26</sup> Further investigations along the lines of the Falaco soliton and the use of minimal surfaces could yield a more analytic solution.

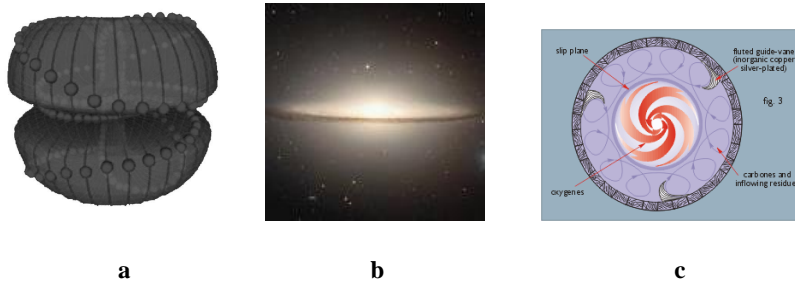


**Figure 9.** Hexagonal or pentagonal cloud structure at the north pole of Jupiter

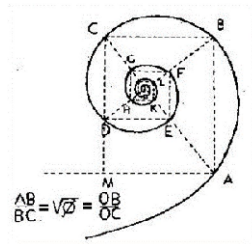


**Figure 10.** (a) Hexagonal pattern at the north pole of Saturn (b) Southern polar storm

A. M. Selvam has modeled turbulence in weather and other systems using Von Karman’s “*law of the wall*”, the Feigenbaum constants for fractal systems and shows self-organization, Phi and incorporates Penrose tiling.<sup>27</sup> We note in passing that Penrose tiles incorporate Phi.<sup>28</sup> We can outline only a few examples here.



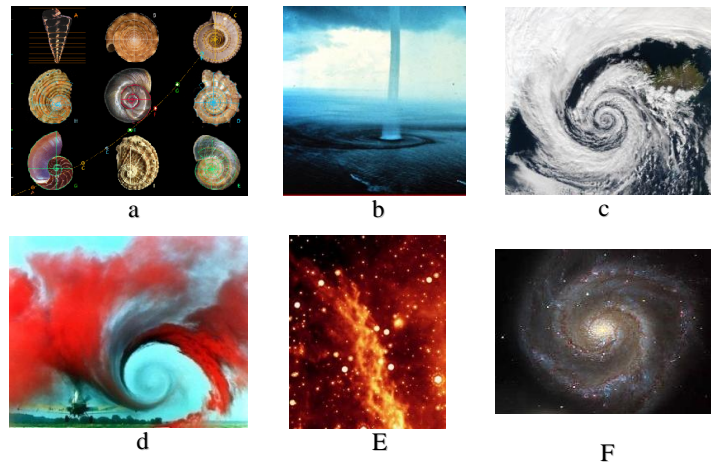
**Figure 11.** (a) Double-Torus flow schematic (b) stars in the galaxy halo travel from the center, out the equator, and in at the poles of the galaxy. The main disc forms between the top and bottom toroidal flows. (c) V. Schaubberger’s pipe design showing how counter-flows at the outside organize the interior flow. There is evidence that the outer halo stars flow in this way.



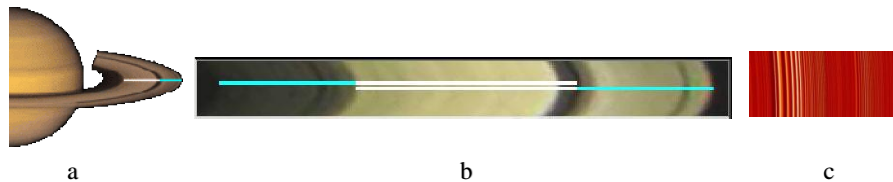
**Figure 12.** In the diagram,  $\frac{AB}{BC} = \sqrt{\phi} = \frac{OB}{OC}$  and the ratio of lengths of any two perpendicular crossing the curve, such as H/C yields Phi

## 5. PHYSICS and BIOLOGY

Now that we have seen basic geometries and flows are ubiquitous, we briefly discuss our expanding understanding of the relationship of life, biology, and consciousness to physics and show that incorporation of these areas with physics is key to fostering unification and a deeper understanding of the universe as a whole.



**Figure 13.** Phi in (a) shells (b) waterspout (c) hurricane (d) aircraft wing-tip vortex (e) double spiral filament (e) Whirlpool Galaxy



**Figure 14.** Phi ratios in rings (a, b) and possible Phi-related ring fine structures of Saturn's rings.

One major discovery has to do the correspondence of the geometry of biology to the symmetry groups of physics, especially the work of V. Hill.<sup>29</sup> Hill first found a geometric mapping involving tetrahedrons, cubes, octahedrons and star-tetrahedrons that beautifully describes the basic relationships of DNA codons and amino acids. For example, the four base pairs of DNA (adenine, thymine, guanine and cytosine) can be mapped to the vertices a tetrahedron. Two tetrahedra map the double DNA strand. Progressing to a third order grouping, we can form 4 octahedrons and 10 tetrahedrons. Each octahedron face then represents a codon triplet coding for one amino acid and each of the 10 tetrahedron's code for an amino acid. Doubling this third order star-tetrahedron configuration gives a complete map for 64 codons encoding 20 amino acids.

Later, Hill, working with Rowlands,<sup>15</sup> found the same pattern was reflected in the organization of physics according to the nilpotent and general rewrite point of view in which a set of nested quaternions, with orders of 2, 4, 8, 16... represent scalars, pseudo-scalars, quaternions, complexified quaternions, and so on. Finally, at level 6, there are sufficient degrees of freedom to represent a fermion (20 components) and then, the Dirac algebra, including time, space, mass and charge (with 64 components). As an aside, this scheme also includes five-fold symmetry and the Fibonacci sequence; any

two numbers of this sequence, when divided, approximate Phi. Here we see basic patterns in the geometry of the universe reflected in biology *and* physics through the Platonic solids – “*nature's code*”.<sup>15,29</sup>

Consider that 98% of the universe we observe is plasma. Much of that contains dust and other matter, and thus qualifies as “*dusty plasma*”. Now we have found observations suggesting that dusty plasma has “*all of the characteristics of life...these interacting complex structures exhibit thermodynamic and evolutionary features thought to be peculiar only to living matter such as bifurcations that serve as ‘memory marks’, self-duplication, metabolic rates in a thermodynamically open system, and non-Hamiltonian dynamics... It is concluded that complex self-organized plasma structures exhibit all the necessary properties to qualify them as candidates for inorganic living matter that may exist in space provided certain conditions allow them to evolve naturally*”.<sup>30</sup> Perhaps we are seeing at a cosmological scale, a process occurring at all scales, even down to the scale of the cell and DNA, or smaller.

At the molecular scale, classical chemistry must now consider the interaction of DNA with the vacuum structure itself to explain the DNA’s stability. E. Rieper, *et al.* show that: “*for realistic parameters nearest neighbour entanglement is present even at room temperature. We quantify the amount of entanglement in terms of... von Neumann entropy... We derive an analytical expression for the binding energy of the coupled chain in terms of entanglement*”.<sup>31</sup> A. Iorio, *et al.*, studying DNA structure, find that: “*Quantum fluctuations... lead to a vacuum interaction that is numerically computed for several configurations of many DNA strands and found to be strongly many-body. This Casimir vacuum interaction can be the “glue” holding together DNA molecules into aggregates*”.<sup>32</sup> This suggests, as we have mentioned, that vacuum interactions are critical at all scales and here are seen in the stability of one of the most stable of molecules and perhaps a *non-local* nature of DNA.

L. Montagnier recently performed a fascinating experiment that suggests that DNA can have influence on water even at macro distances.<sup>33</sup> If confirmed, this will be a key datum for many areas of study. Briefly, a tube containing a dilute solution of DNA was placed next to a tube of pure water. Both were placed in a 7 Hz magnetic field for at least 18 hours. Then the chemicals needed to produce DNA were added to the tube of water. Strands of DNA were found in the water that reproduced the sequence of the original DNA sample with 98% accuracy. Montagnier suggests that electromagnetic signals from the DNA can organize structures in water that can determine DNA sequences. This suggests that, in some cases, the information of DNA can be broadcast or is perhaps ubiquitous. Given that DNA stability depends on vacuum actions, perhaps a strong coupling to the vacuum is involved.

## 6. CONSCIOUSNESS AND CONNECTEDNESS

*“There is a universal flux ...which can be known only implicitly, as indicated by the explicitly definable forms and shapes, some stable and some unstable, that can be abstracted from the universal flux. In this flow, mind and matter... are different aspects of one whole ...movement.” -- David Bohm, Wholeness and the Implicate Order*

All of us experience ourselves as conscious, aware, intentional and intuitive beings. For much of history of science consciousness has been considered an epiphenomena of neural activity. Functional or connectionist models for the brain have explored how this may be explained.<sup>34,35,36</sup> While promising as software and hardware techniques for robotics and A.I. in general, as well as its usefulness in tasks like speech recognition, connectionist models fall short when describing actual human brains and behavior. For example, many neural net models suggest a neuron can be modeled as a *bit*; an on-off switch. This is grossly simplified, since actual neurons have about 1000 synapses and up to seven kinds of neurotransmitters. Most models assume that on-off “*action potentials*” or “*spikes*” are signal carriers, which are “*digital*”. In fact, very few neurons “*spike*” and much processing occurs through analog spread of potentials and from neuropeptides pumped from cell to cell.

In addition, nerve cells grow and change dynamically with dendrites forming and dissolving in less than a second with various longer-term modulations of membrane area, receptor numbers, and the like. A single Purkinje cell in the cerebellum has some 200,000 processes, along with complex dendrite-dendrite connections. The Purkinje cell function is highly significant to the manner in which external and internal electromagnetic signals are processed.<sup>37,38</sup> Despite the optimism of A.I. proponents, we are far from *understanding*, let alone *duplicating*, the nervous system. We're close to Marvin Minsky's summary that we should ignore any brain model for the next 40 years because we have yet to have a clue how it works.<sup>39</sup>

Besides these basic considerations, we have yet to know how memories are stored, or where! Neurophysiologist J. Kroeker calculated that there are too few neurons, or processes, or dendrites or receptor areas etc. to code our actual memories, and there is evidence that we store virtually everything in memory.<sup>40</sup> In a famous example, Wilder Penfield stimulated a bricklayer's cortex and evoked a memory in which a single brick was cut in half and placed.<sup>41</sup> This man had been a bricklayer for decades and had laid thousands upon thousands of bricks. Yet the memory of this single brick was so detailed that they were able to find the building and confirm that there was, indeed, a half-brick at the remembered location! So the actual location and mechanism of memory is still a great mystery. Therefore we must consider the possibility that memories are stored outside the brain. Perhaps, as James Culbertson hypothesizes, memories are actually “*echoes*” of past events, which we access by backtracking along our world lines and are stored in space and time.<sup>42,43</sup> Certainly the

collective experience of humanity includes similar concepts, sometimes called the “Akashic record” or the “collective unconscious” by Jung.

C. Jung, S. Grof, and others report finding truthful and verifiable knowledge through accessing these states. Further, their experience is confirmed by “*the states which shamans experience in their initiatory crises and use in their healing practices, those that native people experience in rites of passage and healing ceremonies, as well as those that were described in the reports of neophytes who underwent initiation in the ancient mysteries of death and rebirth. Holotropic states occur in systematic spiritual practice of yogis, Buddhists, Taoists, Kabbalists, Sufis, and Christian hesychasts and Desert Fathers; they have also been described by mystics of all countries and historical periods. Modern psychiatrists and therapists encounter these states in psychedelic therapy, in deep experiential work without the use of psychoactive substances, in experiments with sensory deprivation and biofeedback, and during therapy of individuals undergoing spontaneous episodes of holotropic states (‘spiritual emergencies’)*”<sup>44</sup> and is congruent with the experience of perhaps all of humanity back at least some 40,000 years.

Another aspect is of this a general presumption that there is a more-or-less fixed “circuitry” in the brain, typified by the single-cell neurophysiological idea that somewhere in the brain there is a “grandmother cell” which codes for the recognition of just such a specific stimulus. However, detailed investigation of eye motions recorded during stereoscopic vision showed that the connection patterns in the brain are highly dynamic with the “local sign” or “meaning” of the output of, say, a retinal cell changes continually as the eyes move.<sup>45,46</sup> With all the studies performed to confirm the mind-brain identity, there are still deep questions about its validity. While there are obvious and known correlates of behavior and function with brain activity,<sup>47</sup> Sir John Eccles, Nobelist for his masterful analysis of the cerebellum, among other work, came to the conclusion, after years of investigation aimed at proving the identity theory, that the brain is a “liaison body” that receives signals from a source beyond the physical – his “interactionist” concept.<sup>48,49</sup> Similarly, Carl Jung once said that after some 50 years of investigation, the case was even stronger that the mind was somewhere beyond the head.

We briefly review the case that mind or consciousness is fundamental to the universe and exhibits properties suggesting that it is intimately connected to everything and a *non-local* or ubiquitous phenomena. Penrose and Hameroff, among others are developing *non-local* models of consciousness that invoke quantum coupling to microtubules. “*Orch OR [orchestrated collapse of the wave function] suggests a connection between brain biomolecular processes and fine-scale structure of the universe...We conclude that consciousness plays an intrinsic role in the universe*”.<sup>50</sup> Similarly, there is a greater general appreciation that the issue of consciousness requires such levels of explanation.<sup>51</sup> To briefly mention another class of evidence that indicates consciousness extends beyond the brain is the near-death experience or NDE. J. Turner, M.D. and others report that patients sometimes have “out of body” (OBE) or near-death experiences (NDE’s) while their brain shows *zero* activity and are “flat-lined”. Yet the

fact that these patients remember conversations or events occurring in the operating theater or elsewhere has been fully verified.<sup>52</sup>

Other observed phenomena extend this view. We now have verified experimental data to demonstrate that we are capable of telepathy,<sup>53</sup> at large distances without apparent signal decrease; remote viewing of the past, present and future at any location; healing at a distance,<sup>54,55,56</sup> psychokinesis; and pre-cognitive dreams.<sup>57,58</sup> As well, there is confirmed evidence from evoked potentials recorded from the human brain cortex<sup>59</sup> and the heart<sup>60,61,62</sup> that both respond to future events *before* their occurrence; in the case of heart, up to about 14 seconds before an event and in the brain, for events some two seconds into the future. For the heart studies, observers were shown random pictures that were emotionally neutral or charged (e.g. sex or violence) and found the heart rate varied in its response several seconds before the picture was displayed.

How can this clearly anticipatory system be explained?

E. Rauscher points out that the observer must be included in quantum theories of the collapse of the wave function. For example, since all beings are, in principle, able to collapse the wave function, consciousness must be a necessary part of the universe.<sup>4,63,64</sup>

Helmut Schmidt performed a fascinating series of experiments in this regard. Random sequences of numbers were generated and copies stored on several read-only memory (ROM) chips. In one part of the study, one of the chips was handed to a subject who was asked to play it back and attempt to change the outcome to, say, all one's as indicated by the flash of a green light. During the trial, each second a new number would be played and either a red or green light would go on. The subject "*willed*" the light to be green.

In other cases, a copy of the chip was *first* shown to a goldfish *before* being shown to a human.

In the case where the human saw the ROM first, when the sequences were checked after the subject had attempted to change the numbers, it was found that the data had indeed been changed from totally random to, say, more ones. The stored copies also changed their statistics and were, apparently, identical

In the case where a *goldfish* saw the chip first, and *then* a human subject attempted to change the ROM's, the statistics on the chips remained the same in all copies. It was concluded that the goldfish had collapsed the wave function for the ROM's preventing their alteration: "*we found significantly positive scoring, odds against chance of 1000:1 for the runs without fish observation but chance scoring for the runs that had been previously displayed to the fish. The difference was statistically significant at the 1% level*".<sup>65</sup> See also [66,67,68,69]. So we now know that at least goldfish are conscious

participants that affect wave function collapse and, by extension, perhaps all beings are observer/participants. It appears that all is conscious! The scale of these effects can be global. Dean Radin, in his global consciousness project, has shown that the mass consciousness of the planet can affect widely dispersed random number generators.<sup>70,71,72</sup>

The state of the observer affects the system observed and can change the results of observation. At the macro level there is feedback between observer and environment, as they are in, fact, one system. For humans this interface includes language. Imagining or dreaming invokes brain activity similar to actual events, as does language. Language can strongly affect observation and thereby affects what *is*.<sup>73</sup>

The previous discussion is a brief overview of these topics. We present some of the evidence by which we conclude that these are real phenomena that must be addressed. One conclusion is that to explain the *psi* phenomena requires utilization of (at least) an eight-dimensional complexified Minkowski space that, while eliminating close time-like loops, permits two or more spatially or temporally separate points to still be adjacent in the hyper-spatial view.<sup>4,74,75,76,77,78,79,80</sup> This accounts for remote viewing of targets distant in space and/or time. Since remote viewing is established to the extent that the probability value (p-value) for such experiments is now about  $\frac{1}{10^{20}}$ , these are actual phenomena. Something like an eight-dimensional perspective is needed to explain the results.<sup>81</sup> We conclude that consciousness likely is ubiquitous, *non-local*, and therefore, fully connected. Consciousness has access to information at every point and, apparently, has access to potentially any space or time. Further, according to the quantum formalism, consciousness is necessary in the universe because of the need for an observer/participator.

## 7. DISCUSSION

*All things by immortal power; Near and Far; Hiddenly; To each other linked are; That thou canst not stir a flower; Without troubling of a star. - English poet, Francis Thompson*

*“In the heaven of Indra, there is said to be a network of pearls, so arranged that if you look at one, you see all the others reflected in it. In the same way, each object in the world is not merely itself, but involves every other object and, in fact, is everything else.” -The Necklace of Indra, The Avatamsaka Sutra*

In this whirlwind tour of many areas we have found that basic geometry and especially the constant Phi are involved with the vacuum structure and codify aspects of biology and DNA and shown a matching pattern in the physics of the rewrite formulation. We have found “*spooky action at a distance*” effects whereby the



structure of DNA is stabilized through coupling to the vacuum and may be capable of impressing its pattern into water at a distance. We then entered a brief discussion of life.

We have seen that life's basis may be built into the very geometry of physics and even dusty plasmas making up 98% of the universe show properties of life. We then found that despite years of attempts at establishing consciousness as an epiphenomenon, a closer view reveals that there is more to this matter. Namely, phenomena broadly classed as "ESP" or "psi" are strongly verified. It has been shown that the consciousness of even a goldfish may collapse the wave function. We can access information from the past, present or future at any location. We suggest this shows that consciousness is an actual force in the universe – "*thoughts are things*" – capable of changing the physical world. It appears that consciousness is shared with all beings: humans, goldfish, dolphins,<sup>82</sup> etc. and that because of its distribution throughout eight-space, is *non-local* and ubiquitous. Therefore consciousness must be included in any complete universal theory.

Finally, we leave you with this thought: D'Arcy Wentworth Thompson,<sup>83</sup> the first mathematical biologist, and others taught that if we see a shell's Phi spiral or the phyllotactic spiraling of a plant, etc., this indicates such a structure either *is* alive or *was* alive. Given the demonstrated distributed effects of consciousness, we can contemplate that the Earth, the Sun, the galaxy, and even the Cosmos may share consciousness. Phi is expressed at all scales and may even be part of the very oscillation of space-time. Ergo, the presence of Phi, as an indicator of life, is telling us that the entire universe is alive; and, since it seems to be expanding, is also growing. According to a cosmology developed recently by E. Rauscher and M. Hyson<sup>84,85,86,87</sup> the universe is undergoing continuous creation of matter and energy.

We conclude from all of the above that everything is alive and conscious.

## ACKNOWLEDGEMENTS

One of us, (E.A.R.) expresses acknowledgement for fruitful discussions with John A. Wheeler, Karl Pribram, and Ilya Prigogine. The other of us (M.T.H.) acknowledges and expresses gratitude to: Nassim Hamein and the Resonance Project; the Sirius Institute of Puna, Hawai'i; A. T. Stanley, and the Barber Family Foundation for their generous support; to S. Newland for encouragement, advice and language sculpting; and to V. Hill for her kind collaboration.

## REFERENCES

- 
- <sup>1</sup> M. Livio, *The Golden Ratio: The Story of Phi, the World's Most Astonishing Number*, Broadway, October 29, 2002.
- <sup>2</sup> B. D. Josephson, F. Pallikari-Viras, *Biological Utilization of Quantum Non-locality*, *Foundations of Physics*, Vol. 21, No. 2, pp.197-207, [www.tcm.phy.cam.ac.uk/~bdj10/papers/bell.html](http://www.tcm.phy.cam.ac.uk/~bdj10/papers/bell.html), Feb. 1991.
- <sup>3</sup> J. Utts and B. D. Josephson, *The Paranormal: the Evidence and its Implications for Consciousness*, *Times Higher Education Supplement's special section on Consciousness linked to the Tucson II conference "Toward a Science of Consciousness"*, page (v), [www.tcm.phy.cam.ac.uk/~bdj10/psi/tucson.psi](http://www.tcm.phy.cam.ac.uk/~bdj10/psi/tucson.psi), Apr. 5th. 1996.
- <sup>4</sup> E. A. Rauscher and R. Amoroso, *Orbiting the Moons of Pluto: Solving Einstein's, Maxwell's, Schrodinger's and Dirac Equations in Complex Space*, World Scientific, 2011.
- <sup>5</sup> D. Kaiser, *How the Hippies Saved Physics*, W. W. Norton & Co., 2011.
- <sup>6</sup> R. Buckminster Fuller, *Synergetics: Explorations in the Geometry of Thinking*, Macmillan Pub. Co., New edition, April 1982, and Personal Communication (E.A.R. & M.T.H.).
- <sup>7</sup> Perhaps: "*Fee, Phi, Fo Fum, this is the spin of the continuum*"?
- <sup>8</sup> A. Battaner, *The Fractal Octahedron Network of the Large Scale Structure*, Astrophysics abstract, astro-ph/9801276, <http://xxx.lanl.gov/abs/astro-ph/980126>, Jan. 28, 1998.
- <sup>9</sup> A. Battaner and E. Florido, *The Egg-Carton Universe*, Astrophysics abstract, Astro-ph/9802009, <http://xxx.lanl.gov/abs/astro-ph/980200>, Feb. 2, 1998.
- <sup>10</sup> This preliminary result must be checked. I include this because, should this be verified, it is significant.
- <sup>11</sup> W. K. Rhim, M. Collender, M. T. Hyson, W.T. Simms and D. D. Elleman, *Development of an Electrostatic Positioner for Space Material Processing*, *Rev. Sci. Instruments* **56**:306-317, [www.planetpuna.com/Levitation/P-00.htm](http://www.planetpuna.com/Levitation/P-00.htm), 1985.
- <sup>12</sup> R. M. Kiehn, *The Falaco Soliton: Cosmic Strings in a Swimming Pool*, R. M. Kiehn, Physics Department, University of Houston, arXiv:gr-qc/0101098v1, 2006.
- <sup>13</sup> Used with permission of its originator, Andrew Cox, ©2007, and Personal Communication (M. T. H.).
- <sup>14</sup> P. Rowlands, *et al.*, *Zero to Infinity: the foundations of physics*, World Scientific Publishing Co. Pte. Ltd., 2007 and Personal Communication with M. T. H. and E. A. R.
- <sup>15</sup> N. Hamein and E. A. Rauscher, *Spinors, Twistors, Quaternions, and the "Spacetime" Torus Topology, Logic and Semantics in Front of Nanoscale Physics*; 6th BCSCMsG International Symposium on Rewrite Science; V1th International Symposium in Honor of Jean-Pierre Vigièr. Partial Proceedings of the Eighth International Conference CASYS'07 on Computing Anticipatory Systems, Institute of Mathematics, Liège, Belgium, August 6-11, 2007 D. M. Dubois (Ed.), Publ. by CHAOS, Vol. 22, 2008. ISSN 1373-5411 ISBN 2-930396-09-1.
- <sup>16</sup> N. Hamein and E.A. Rauscher, "The origin of spin: a consideration of torque and Coriolis forces in Einstein's field equations and grand unification theory," in *Beyond the Standard Model: Searching for Unity in Physics*, Eds. R.L. Amoroso. B. Lehnert & J-P Vigièr, Oakland: The Noetic Press, July (2005).
- <sup>17</sup> N. Hamein, M. Hyson, E. A. Rauscher, *Scale Unification: a Universal Scaling Law for Organized Matter*, in *Proceedings of The Unified Theories Conference*, Cs Varga, I. Dienes & R.L. Amoroso (eds.), pp. 84-103, 2008.
- <sup>18</sup> N. Hamein, *The Schwarzschild Proton*, AIP CP 1303, ISBN 978-0-7354-0858-6, pp. 95-100, December 2010.
- <sup>19</sup> N. Hamein, *The Cosmological Constant and the Schwarzschild Proton*, (to be presented at CASYS 2011), University of Liège, Liège, Belgium, 2011.
- <sup>20</sup> Callum Coats, *Living Energies: An Exposition of Concepts Related to the Theories of Viktor Schauberger*, Newleaf, 2nd edition, February 2002.
- <sup>21</sup> D. Carollo, T.C. Beers, *The Dichotomy of the Galactic Halo of the Milky Way*, JINA Frontiers, [www.jinaweb.org/events/frontiers07/talks/daniela\\_carollo.pdf](http://www.jinaweb.org/events/frontiers07/talks/daniela_carollo.pdf), 2007.
- <sup>22</sup> J. Szklarski and G. Rüdiger, *Ekman-Hartmann Layer in a Magnetohydrodynamic Taylor-Couette Flow*, *Physical Review E* **76**, 066308 2007.

- 
- <sup>23</sup> M. S. Seigar, D. Kennefick, J. Kennefick, and C. H. S. Lacy, Discovery of a Relationship Between Spiral Arm Morphology and Supermassive Black Hole Mass in Disk Galaxies, arXiv:0804.0773v3 [astro-ph], 2008.
- <sup>24</sup> H. Weiss and V. Weiss, The Golden Mean as Clock Cycle of Brain Waves, Chaos, Solitons & Fractals, **18**, Issue 4, pgs 643-652, November 2003.
- <sup>25</sup> Dr. L. Kauffman, Personal Communication (M.T.H.).
- <sup>26</sup> V. J. Hill and P. Rowlands, Nature's code III, Proceedings of XXX ANPA Conference, Cambridge, August 2008, 2009 and Personal Communication with M. T. H. and E. A. R.
- <sup>27</sup> A. M. Selvam, A General Systems Theory for Chaos, Quantum Mechanics and Gravity for Dynamical Systems of All Space-Time Scales, <http://arxiv.org/ftp/physics/papers/0503/0503028.pdf>
- <sup>28</sup> Wolfram Math World, Penrose Tiles, <http://mathworld.wolfram.com/PenroseTiles.html>
- <sup>29</sup> V. J. Hill and P. Rowlands, Nature's Code, AIP Conference Proceedings, 1051, 117-26, 2008.
- <sup>30</sup> V. N. Tsytovich, G. E. Morfill, V. E. Fortov, N. G. Gusein-Zade, B. A. Klumov and S. V. Vladimirov, From plasma crystals and helical structures towards inorganic living matter, New Journal of Physics **9**, pp. 263, 2007.
- <sup>31</sup> E. Rieper, J. Anders and V. Vedral, Quantum entanglement between the electron clouds of nucleic acids in DNA, 2011.
- <sup>32</sup> A. Iorio, Samik Sen, Siddhartha Sen, V. Holesovickach, Do quantum effects hold together DNA condensates?, arXiv:0806.3130v1 [q-bio.QM], 2008.
- <sup>33</sup> L. Montagnier, J. Aissa, E. Del Giudice, C. Lavalée, A. Tedeschi, and G. Vitiello, DNA waves and water. arXiv:1012.5166v1 [q-bio.OT] 23 Dec 2010.
- <sup>34</sup> M. T. Hyson, A Model of the Visual System for Tree Species Recognition, Dissertation, U. of Miami, Coral Gables, Florida, 1976.
- <sup>35</sup> M. T. Hyson, A. Trimpi, et al., MOWBOT: A Feasibility Study for an Automated Autonomous Lawn Maintenance Vehicle, Hy Tech, Glendale Ca. [for Yamaha Motors Corp.], 1987.
- <sup>36</sup> M. T. Hyson, and L. D. Jaffe, Teleoperation, Robotics and Man - an Overview, In: Teleoperator Maneuvering Technology Requirements and Assessment for Proximity Operations (P. A. Penzo and S. J. Boulton, Ed.s) Jet Propulsion Laboratory Report No. D-1419, June, 1984.
- <sup>37</sup> E. A. Rauscher and W. Van Bise, External Magnetic Field Impulse Pacemaker: Non-Invasive Method and Apparatus for Modulating Brain Signals Through an External Magnetic or Electric Field to Pace the Heart and Reduce Pain, U.S. Patent Number 4723536, issued Feb. 9, 1988.
- <sup>38</sup> E. A. Rauscher and W. Van Bise, Non-Invasive Method and Apparatus for Modulating Brain Signals Through and External Magnetic or Electric Field to Reduce Pain, U.S. Patent Number 4889526, issued Dec. 26, 1989.
- <sup>39</sup> Marvin Minsky, (a pioneer of A.I.; co-developer of LISP), MIT, Personal Communication (M. T. H.).
- <sup>40</sup> J. Kroeker, California Institute of Technology, BioInformation Systems & Eliza Corporation, Beverly, MA., 2011 and Personal Communication (M. T. H.).
- <sup>41</sup> Penfield, Wilder, The Mystery of the Mind, Princeton University Press, 1975.
- <sup>42</sup> J. T. Culbertson, The Minds Of Robots: Sense Data, Memory Images, and Behavior In Conscious Automata, University Of Illinois Press, Urbana, 1963 and Personal Communication with M. T. H. and E. A. R.
- <sup>43</sup> J. T. Culbertson, Consciousness: Natural and Artificial; The Physical Basis and Influence on Behavior of Sensations, Percepts, Memory Images and Other Mental Images Experienced by Humans, Animals and Machines, Roslyn Heights. NY: Libra, 1982.
- <sup>44</sup> S. Grof, Evidence for the Akashic Field from Modern Consciousness Research, [www.stanislawgrof.com](http://www.stanislawgrof.com), 2011 and Personal Communication with E. A. R.
- <sup>45</sup> M. T. Hyson, B. Julesz, and D. H. Fender, Eye Movements and Neural Remapping During Fusion of Misaligned Random Dot Stereograms, J. Opt. Soc. Am. 73:1665-1673, [www.planetpuna.com/ReMapping/P-1.htm](http://www.planetpuna.com/ReMapping/P-1.htm), 1983.
- <sup>46</sup> M. T. Hyson, The Perception of Random Dot Stereograms, Thesis, U. of Miami, Coral Gables, Florida, 1973.

- 
- <sup>47</sup> T. Shipley, and M. T. Hyson, Amplitude Decrements in Brain Potentials in Man Evoked by Repetitive Auditory, Visual and Intersensory Stimulation, *Sensory Processes* 1:338-353, 1977.
- <sup>48</sup> J. C. Eccles, *Evolution of the Brain, Creation of the Self*, Psychology Press, 1989 and *Personal Communication with E. A. R. on evolution of the brain*.
- <sup>49</sup> K. R. Popper, J. C. Eccles, *The Self and Its Brain: Argument for Interactionism*, Routledge, February, 1984.
- <sup>50</sup> R. Penrose and S. Hameroff, *Consciousness in the Universe: Neuroscience, Quantum Space-Time Geometry and Orch OR Theory*, *Journal of Cosmology*, Volume 14, April-May, 2011.
- <sup>51</sup> M. T. Hyson, A. Barber, P. S. Newland, *Quantum Neurobiology: A New View of Consciousness*, The Barber Family Foundation, Hilo, Hawai'i, 2008.
- <sup>52</sup> J. L. Turner, *Medicine, Miracles, and Manifestations: A Doctor's Journey Through the Worlds of Divine Intervention, Near-Death Experiences, and Universal Energy*, Career Press, 2009.
- <sup>53</sup> J. B. Rhine, *The Reach of the Mind* (New York and London, 1928).
- <sup>54</sup> E. A. Rauscher and B. Rubik, *Human Volitional Effects on a Model Bacterial System*, *PSI Research Journal* Vol. 2, pp. 38, 1983.
- <sup>55</sup> E. A. Rauscher, *Human Volitional Effects on a Model Bacterial System*, *Subtle Energies* Vol. 1, pps. 21-41, 1990.
- <sup>56</sup> B. Rubik and E. A. Rauscher, *Human Volitional Effects on a Model Bacterial System*, in: *Silver Threads: Twentyfive Years of Parapsychology Research*, Eds.: B. Kane, J. Milley, and D. Brown, Praeger, pps. 181-187, 1993.
- <sup>57</sup> E. A. Rauscher and R. Targ, *The Speed of Thought: Investigation of Complex Space-Time Metric to Describe Psychic Phenomena*, *Journal of Scientific Exploration*, Vol.15, No.3, Fall 2001.
- <sup>58</sup> E. A. Rauscher, *Longitudinal Comparison of Local and Long Distance Remote Perception Phenomena*, in: *Silver Threads: Twentyfive Years of Parapsychology Research*, Eds.: B. Kane, J. Milley, and D. Brown, Praeger, pps. 64-77, 1993.
- <sup>59</sup> A. Barber, Barber Family Foundation, Hilo, Hawai'i, *Personal Communication concerning the work of Dr.'s F. Plum and J. Schiff*.
- <sup>60</sup> R. T. Bradley, *The Psychophysiology of Intuition: A Quantum-Holographic Theory of Nonlocal Communication*, *World Futures*, 63: 61-97, 2007.
- <sup>61</sup> R. McCraty, M. Atkinson, and R. T. Bradley, *Electrophysiological Evidence of Intuition: Part 1. The Surprising Role of the Heart*, *The Journal of Alternative and Complementary Medicine* Volume 10, Number 1, pp. 133-143, 2004.
- <sup>62</sup> R. McCraty, M. Atkinson, and R. T. Bradley, *Electrophysiological Evidence of Intuition: Part 2. A System-Wide Process*, *The Journal of Alternative and Complementary Medicine* Volume 10, Number 2, pp. 325-336, 2004.
- <sup>63</sup> E. A. Rauscher, *Quantum Mechanics and the Role for Consciousness in the Physical World*, *Subtle Energies & Energy Medicine*, Vol. 16, No. 1, pps. 1-41, 2006.
- <sup>64</sup> E. A. Rauscher, editor and chapter, *The Iceland Papers: Frontiers of Physics Conference*, select papers on experimental and theoretical research on physics of consciousness, Foreword by B.D. Josephson, and A. Puharich, Assentia Research Associates, Amherst, Wisconsin 54406, August 1979, 1995.
- <sup>65</sup> H. Schmidt, *Deviating Pre-recorded Computer Chips*, in: D. H. Weiner and D. I. Radin, [Eds], *Research in Parapsychology*, Scarecrow Press, [www.worldkungfu.com/personal5.html](http://www.worldkungfu.com/personal5.html), January 1990.
- <sup>66</sup> H. Schmidt, *Observation of a Psychokinetic Effect Under Highly Controlled Conditions*, *Journal of Parapsychology*, Vol. 57, [www.fourmilab.ch/rpkp/observ.html](http://www.fourmilab.ch/rpkp/observ.html), Dec. 1993.
- <sup>67</sup> H. Schmidt, *Addition Effect for PK on Prerecorded Targets*, *Journal of Parapsychology*, Vol. 49, [www.fourmilab.ch/rpkp/addition.html](http://www.fourmilab.ch/rpkp/addition.html), Sept. 1985.
- <sup>68</sup> H. Schmidt, *Correlation Between Mental Processes and External Random Events*, *Journal of Scientific Exploration*, Vol. 4, No. 2, pp. 233-241, [www.scientificexploration.org/journal/jse\\_04\\_2\\_schmidt.pdf](http://www.scientificexploration.org/journal/jse_04_2_schmidt.pdf), 1990.
- <sup>69</sup> H. Schmidt and H. Stapp, *PK with Prerecorded Random Events and the Effects of Pre-observation*, *The Journal of Parapsychology*, Vol. 57, No. 4, pps. 331-349, Dec. 1993.

- 
- <sup>70</sup> D. L. Radin and R. D. Nelson, "Evidence for Consciousness-Related Anomalies in Random Physical Systems," *Foundations of Physics*, Vol. 19, No. 12, pp.1499-1514, [www.fourmilab.ch/rpkp/pk-rad.html](http://www.fourmilab.ch/rpkp/pk-rad.html), Dec. 1989.
- <sup>71</sup> D. Radin, *The Conscious Universe: The Scientific Truth of Psychic Phenomena*, HarperOne, July, 1997.
- <sup>72</sup> D. Radin, *Entangled Minds*, Paraview Pocket Books, April 25, 2006.
- <sup>73</sup> P. S. Newland, *A Primer on Language Sculpting*, Sirius Institute, Puna, Hawai'i, 2011, and *Personal Communication* (M. T. H.).
- <sup>74</sup> E. A. Rauscher and R. Targ, "Why Only Four Dimensions Will Not Explain Non-Locality", *Journal of Scientific Explorations* 16, 655-658, 2002.
- <sup>75</sup> E. A. Rauscher, "Macroscopic Connectedness in Multidimensional Geometries and the Quantum Observer," *International Conference on Science and Consciousness*, Cordoba, Spain, November 1979.
- <sup>76</sup> E. A. Rauscher and C. Ramon, "Superluminal Transformations in Complex Minkowski Spaces," *LBL-9752*, September 1979 and *Foundation of Phys.* 10, 661, 1980.
- <sup>77</sup> E. A. Rauscher and R. Targ, Investigation of a Complex Space-Time Metric to Describe Pre-cognition of the Future, in: *Frontiers of Time: Retrocausation, Experiment and Theory*, Ed.: D. P. Sheehan, AIP Conference Proceedings Vol. 863, pps. 121-146, 2006.
- <sup>78</sup> E. A. Rauscher, *A Theoretical Model of Remote Perception Phenomena*, in: *Silver Threads: Twentyfive Years of Parapsychology Research*, Eds.: B. Kane, J. Milley and D. Brown, Praeger, pps. 141-155, 1993.
- <sup>79</sup> E. A. Rauscher and R. L. Amoroso, *The Physical Implications of Multidimensional Geometries and Measurement*, *International Journal of Computing Anticipatory Systems*, Ed.: D. M. Dubois, Vol. 19, pps. 161-177, 2006.
- <sup>80</sup> E. A. Rauscher and R. L. Amoroso, *The Schrodinger Equation in Complex Minkowski Space, Non-Locality and Anticipatory Systems*, *International Journal of Computing Anticipatory Systems*, Ed.: D. M. Dubois, Vol. 22, pps. 370-388, 2008.
- <sup>81</sup> M. Coyle, *Remote Viewing: Physics, Parapsychology, and Neuroscience*, [www.rense.com/ufo/remoterviewmike.htm](http://www.rense.com/ufo/remoterviewmike.htm), 2007.
- <sup>82</sup> M. T. Hyson and P. S. Newland, *Dolphins, Therapy & Autism*, Sirius Institute, Puna, Hawai'i, [www.planetpuna.com/dolphin-paper/Dolphin-Paper-PDF/Dolphin-Paper-Final.pdf](http://www.planetpuna.com/dolphin-paper/Dolphin-Paper-PDF/Dolphin-Paper-Final.pdf), 2003.
- <sup>83</sup> D'Arcy Wentworth Thompson, *On Growth and Form: The Complete Revised Edition*, Dover Publications, Revised edition, June 23, 1992.
- <sup>84</sup> E. A. Rauscher and M. T. Hyson, *Geometrical Constraints in an N-dimensional Topology in Quantum Mechanics and Cosmology*, (to be presented at CASYS 2011, University of Liège, Liège, Belgium), August, 2011.
- <sup>85</sup> I. Prigogine, J. Gehenaut, E. Gunzigt, and P. Nardonet, *Thermodynamics of Cosmological Matter Creation*, *Proc. Natl. Acad. Sci. USA Physics*, **85**, pp. 7428-7432, October 1988, Private Communication (E. A. R.) with I. Prigogine. Interestingly, these authors also came to a continuous creation model.
- <sup>86</sup> E. A. Rauscher, *Cosmology and Quantum Gravity*, in: *Beyond the Standard Model: Searching for Unity in Physics*, Eds.: R. L. Amoroso, B. Lehnert and J-P Vigièr, pps. 43-72, 2005.
- <sup>87</sup> E. A. Rauscher, *A Unifying Theory of Fundamental Processes*, LBNL/UCB Press, UCRL20808, 1971.