

Differential Topology

Bjørn Ian Dundas

26th June 2002

Contents

1	Preface	7
2	Introduction	9
2.1	A robot's arm:	9
2.1.1	Question	11
2.1.2	Dependence on the telescope's length	12
2.1.3	Moral	13
2.2	Further examples	14
2.2.1	Charts	14
2.2.3	Compact surfaces	15
2.2.8	Higher dimensions	19
3	Smooth manifolds	21
3.1	Topological manifolds	21
3.2	Smooth structures	24
3.3	Maximal atlases	28
3.4	Smooth maps	30
3.5	Submanifolds	35
3.6	Products and sums	39
4	The tangent space	43
4.0.1	Predefinition of the tangent space	43
4.1	Germes	44
4.2	The tangent space	47
4.3	Derivations	52
5	Vector bundles	57
5.1	Topological vector bundles	58
5.2	Transition functions	62
5.3	Smooth vector bundles	63
5.4	Pre-vector bundles	66
5.5	The tangent bundle	68

6	Submanifolds	75
6.1	The rank	75
6.2	The inverse function theorem	77
6.3	The rank theorem	78
6.4	Regular values	81
6.5	Immersions and imbeddings	88
6.6	Sard's theorem	91
7	Partition of unity	93
7.1	Definitions	93
7.2	Smooth bump functions	94
7.3	Refinements of coverings	96
7.4	Existence of smooth partitions of unity on smooth manifolds.	98
7.5	Imbeddings in Euclidean space	99
8	Constructions on vector bundles	101
8.1	Subbundles and restrictions	101
8.2	The induced bundles	105
8.3	Whitney sum of bundles	108
8.4	More general linear algebra on bundles	109
8.4.1	Constructions on vector spaces	109
8.4.2	Constructions on vector bundles	112
8.5	Riemannian structures	113
8.6	Normal bundles	115
8.7	Transversality	117
8.8	Orientations	119
8.9	An aside on Grassmann manifolds	120
9	Differential equations and flows	123
9.1	Flows and velocity fields	124
9.2	Integrability: compact case	130
9.3	Local flows	132
9.4	Integrability	134
9.5	Ehresmann's fibration theorem	136
9.6	Second order differential equations	141
9.6.7	Aside on the exponential map	142
10	Appendix: Point set topology	145
10.1	Topologies: open and closed sets	145
10.2	Continuous maps	147
10.3	Bases for topologies	148
10.4	Separation	148
10.5	Subspaces	149

10.6	Quotient spaces	150
10.7	Compact spaces	150
10.8	Product spaces	152
10.9	Connected spaces	152
10.10	Appendix 1: Equivalence relations	154
10.11	Appendix 2: Set theoretical stuff	154
	10.11.2 De Morgan's formulae	154
11	Appendix: Facts from analysis	159
11.1	The chain rule	159
11.2	The inverse function theorem	160
11.3	Ordinary differential equations	160
12	Hints or solutions to the exercises	163

Chapter 1

Preface

There are several excellent texts on differential topology. Unfortunately none of them proved to meet the particular criteria for the new course for the civil engineering students at NTNU. These students have no prior background in point-set topology, and many have no algebra beyond basic linear algebra. However, the obvious solutions to these problems were unpalatable. Most “elementary” text books were not sufficiently to-the-point, and it was no space in our curriculum for “the necessary background” for more streamlined and advanced texts.

The solutions to this has been to write a rather terse mathematical text, but provided with an abundant supply of examples and exercises with hints. Through the many examples and worked exercises the students have a better chance at getting used to the language and spirit of the field before trying themselves at it. This said, the exercises are an essential part of the text, and the class has spent a substantial part of its time at them.

The appendix covering the bare essentials of point-set topology was covered at the beginning of the semester (parallel to the introduction and the smooth manifold chapters), with the emphasis that point-set topology was a tool which we were going to use all the time, but that it was NOT the subject of study (this emphasis was the reason to put this material in an appendix rather at the opening of the book).

The text owes a lot to Bröcker and Jänich’s book, both in style and choice of material. This very good book (which at the time being unfortunately is out of print) would have been the natural choice of textbook for our students had they had the necessary background and mathematical maturity. Also Spivak, Hirsch and Milnor’s books have been a source of examples.

These notes came into being during the spring semester 2001. I want to thank the listeners for their overbearance with an abundance of typographical errors, and for pointing them out to me. Special thanks go to Håvard Berland and Elise Klaveness.

Chapter 2

Introduction

The earth is round. At a time this was fascinating news and hard to believe, but we have grown accustomed to it even though our everyday experience is that the earth is flat. Still, the most effective way to illustrate it is by means of maps: a globe is a very neat device, but its global(!) character makes it less than practical if you want to represent fine details.

This phenomenon is quite common: locally you can represent things by means of “charts”, but the global character can’t be represented by one single chart. You need an entire atlas, and you need to know how the charts are to be assembled, or even better: the charts overlap so that we know how they all fit together. The mathematical framework for working with such situations is manifold theory. These notes are about manifold theory, but before we start off with the details, let us take an informal look at some examples illustrating the basic structure.

2.1 A robot’s arm:

To illustrate a few points which will be important later on, we discuss a concrete situation in some detail. The features that appear are special cases of general phenomena, and hopefully the example will provide the reader with some *deja vue* experiences later on, when things are somewhat more obscure.

Consider a robot’s arm. For simplicity, assume that it moves in the plane, has three joints, with a telescopic middle arm (see figure).

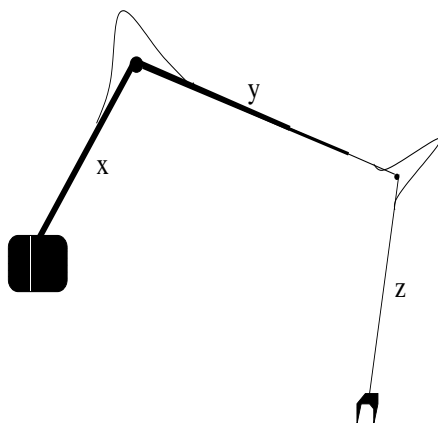

Call the vector defining the inner arm x , the second arm y and the third arm z . Assume $|x| = |z| = 1$ and $|y| \in [1, 5]$. Then the robot can reach anywhere inside a circle of radius 7. But most of these positions can be reached in several different ways.

In order to control the robot optimally, we need to understand the various configurations, and how they relate to each other.

As an example let $P = (3, 0)$, and consider all the possible positions that reach this point, i.e., look at the set T of all (x, y, z) such that

$$x + y + z = (3, 0), \quad |x| = |z| = 1, \quad \text{and} \quad |y| \in [1, 5].$$

We see that, under the restriction $|x| = |z| = 1$, x and z can be chosen arbitrary, and determine y uniquely. So T is the same as the set

$$\{(x, z) \in \mathbf{R}^2 \times \mathbf{R}^2 \mid |x| = |z| = 1\}$$

We can parameterize x and z by angles if we remember to identify the angles 0 and 2π . So T is what you get if you consider the square $[0, 2\pi] \times [0, 2\pi]$ and identify the edges as in the picture below.

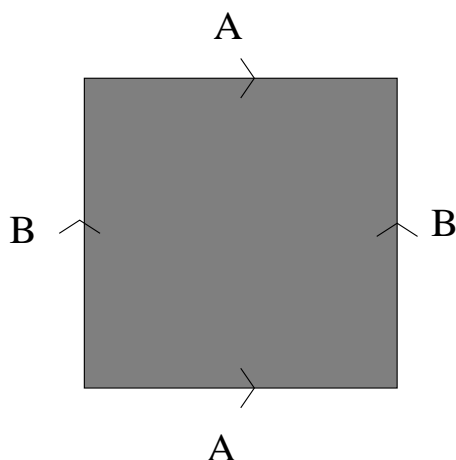

In other words: The set of all positions such that the robot reaches $(3, 0)$ is the same as the torus.

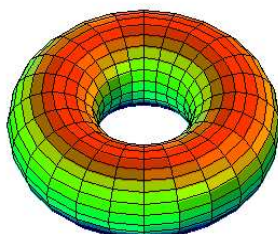

This is also true topologically: “close configurations” of the robot’s arm correspond to points close to each other on the torus.

2.1.1 Question

What would the space S of positions look like if the telescope got stuck at $|y| = 2$?

Partial answer to the question: since $y = (3, 0) - x - z$ we could try to get an idea of what points of T satisfy $|y| = 2$ by means of inspection of the graph of $|y|$. Below is an illustration showing $|y|$ as a function of T given as a graph over $[0, 2\pi] \times [0, 2\pi]$, and also the plane $|y| = 2$.

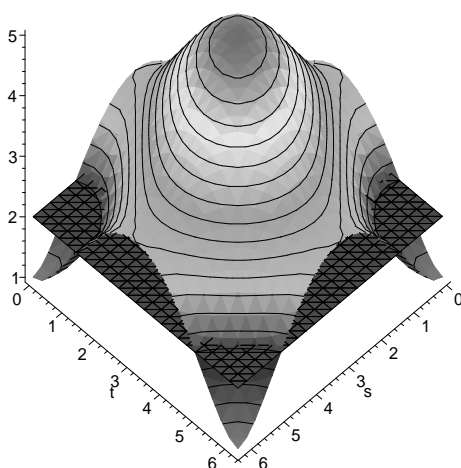

The desired set S should then be the intersection:

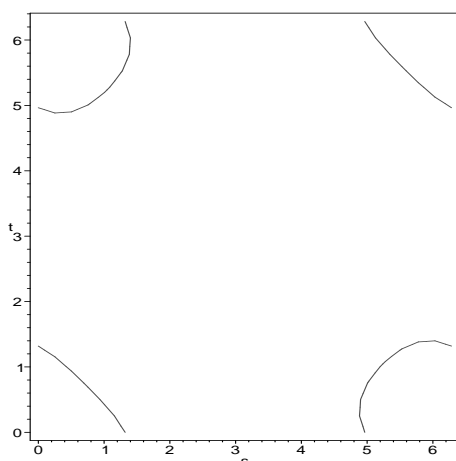

It looks a bit weird before we remember that the edges of $[0, 2\pi] \times [0, 2\pi]$ should be identified. On the torus it looks perfectly fine; and we can see this if we change our perspective a bit. In order to view T we chose $[0, 2\pi] \times [0, 2\pi]$ with identifications along the boundary. We could just as well have chosen $[-\pi, \pi] \times [-\pi, \pi]$, and then the picture would have looked like the following:

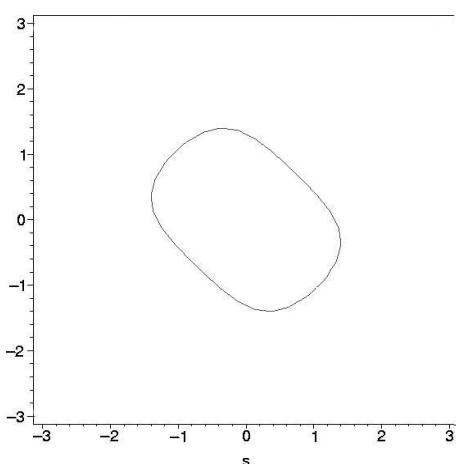

It does not touch the boundary, so we do not need to worry about the identifications. As a matter of fact, the set S is homeomorphic to the circle (we can prove this later).

2.1.2 Dependence on the telescope's length

Even more is true: we notice that S looks like a smooth and nice picture. This will not happen for all values of $|y|$. The exceptions are $|y| = 1$, $|y| = 3$ and $|y| = 5$. The values 1 and 5 correspond to one-point solutions. When $|y| = 3$ we get a picture like the one below (it really ought to touch the boundary):

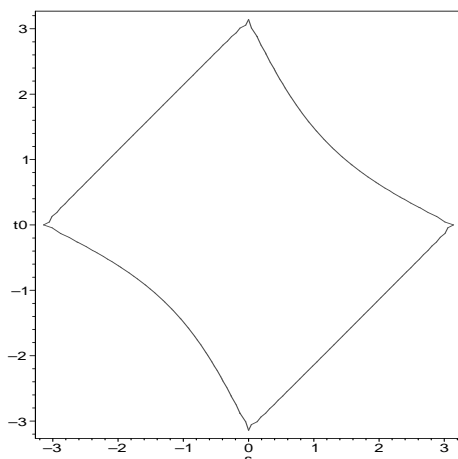

In the course we will learn to distinguish between such circumstances. They are qualitatively different in many aspects, one of which becomes apparent if we view the example with $|y| = 3$ with one of the angles varying in $[0, 2\pi]$ while the other varies in $[-\pi, \pi]$:

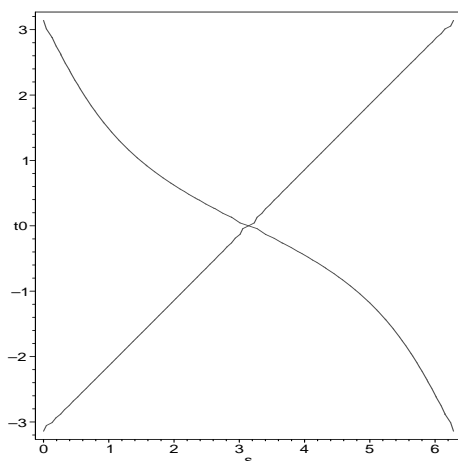

With this “cross” there is no way our solution space is homeomorphic to the circle. You can give an interpretation of the picture above: the straight line is the movement you get if you let $x = z$ (like the wheels on an old fashioned train), while on the other x and z rotates in opposite directions (very unhealthy for wheels on a train).

2.1.3 Moral

The configuration space T is smooth and nice, and we got different views on it by changing our “coordinates”. By considering a function on it (in our case the length of y) we got that when restricting to subsets of T that corresponded to certain values of our function, we could get qualitatively different situations according to what values we were looking at.

2.2 Further examples

- “Phase spaces” in physics (e.g. robot example above);
- The surface of the earth;
- Space-time is a four dimensional manifold. It is not flat, and its curvature is determined by the mass distribution;
- If $f: \mathbf{R}^n \rightarrow \mathbf{R}$ is a map and y a real number, then the inverse image

$$f^{-1}(y) = \{x \in \mathbf{R}^n | f(x) = y\}$$

is often a manifold. Ex: $f: \mathbf{R}^2 \rightarrow \mathbf{R}$ $f(x) = |x|$, then $f^{-1}(1)$ is the unit circle S^1 (c.f. the submanifold chapter);

- {All lines in \mathbf{R}^3 through the origin}= “The real projective plane” \mathbf{RP}^2 (see next chapter);
- The torus (see above);
- The Klein bottle (see below).

2.2.1 Charts

Just like the surface of the earth is covered by charts, the torus in the robot’s arm was viewed through flat representations. In the technical sense of the word the representation was not a “chart” since some points were covered twice (just as Siberia and Alaska have a tendency to show up twice on some maps). But we may exclude these points from our charts at the cost of having to use more overlapping charts. Also, in the robot example we saw that it was advantageous to operate with more charts.

Example 2.2.2 To drive home this point, please play Jeff Weeks’ “Torus Game” on

<http://humber.northnet.org/weeks/TorusGames/>

for a while.

The space-time manifold really brings home the fact that manifolds must be represented intrinsically: the surface of the earth is seen as a sphere “in space”, but there is no space which should naturally harbor the universe, except the universe itself. This opens up the fascinating question of how one can determine the shape of the space in which we live.

2.2.3 Compact surfaces

This section is rather autonomous, and may be read at leisure at a later stage to fill in the intuition on manifolds.

To simplify we could imagine that we were two dimensional beings living in a static closed surface. The sphere and the torus are familiar surfaces, but there are many more. If you did example 2.2.2, you were exposed to another surface, namely the Klein bottle. This has a plane representation very similar to the Torus: just reverse the orientation of a single edge.

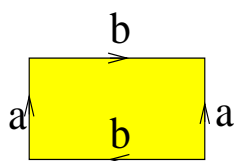

A plane representation of the Klein bottle: identify along the edges in the direction indicated.

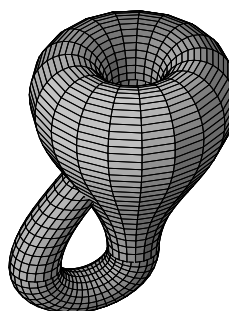

A picture of the Klein bottle forced into our three-dimensional space: it is really just a shadow since it has self intersections. If you insist on putting this two-dimensional manifold into a flat space, you got to have at least four dimensions available.

Although this is an easy surface to describe (but frustrating to play chess on), it is too complicated to fit inside our three-dimensional space: again a manifold is **not** a space inside a flat space. It is a locally Euclidean space. The best we can do is to give an “immersed” (with self-intersections) picture.

As a matter of fact, it turns out that we can write down a list of all compact surfaces. First of all, surfaces may be divided into those that are orientable and those that are not. *Orientable* means that there are no paths our two dimensional friends can travel and return to home as their mirror images (is that why some people are left-handed?).

All connected compact orientable surfaces can be gotten by attaching a finite number of handles to a sphere. The number of handles attached is referred to as the *genus* of the surface.

A *handle* is a torus with a small disk removed (see the figure). Note that the boundary of the holes on the sphere and the boundary of the hole on each handle are all circles, so we glue the surfaces together in a smooth manner along their common boundary (the result of such a gluing process is called the *connected sum*, and some care is required).

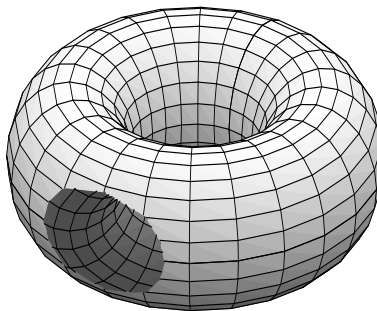

A handle: ready to be attached to another 2-manifold with a small disk removed.

Thus all orientable compact surfaces are surfaces of pretzels with many holes.

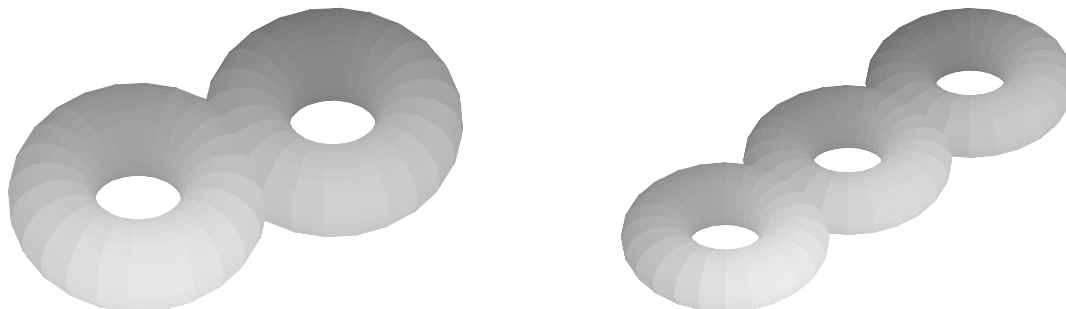

An orientable surface of genus g is gotten by gluing g handles (the smoothening out has yet to be performed in these pictures)

There are nonorientable surfaces too (e.g. the Klein bottle). To make them consider a Möbius band. Its boundary is a circle, and so cutting a hole in a surface you may glue in a Möbius band in. If you do this on a sphere you get the projective plane (this is exercise 2.2.6). If you do it twice you get the Klein bottle. Any nonorientable compact surface can be obtained by cutting a finite number of holes in a sphere and gluing in the corresponding number of Möbius bands.

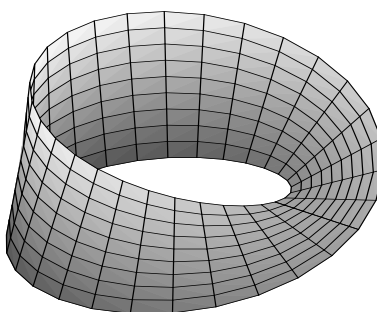

A Möbius band: note that its boundary is a circle.

The reader might wonder what happens if we mix handles and Möbius bands, and it is a strange fact that if you glue g handles and $h > 0$ Möbius bands you get the same as if

you had glued $h + 2g$ Möbius bands! Hence, the projective plane with a handle attached is the same as the Klein bottle with a Möbius band glued onto it. But fortunately this is it; there are no more identifications among the surfaces.

So, any (connected compact) surface can be gotten by cutting g holes in S^2 and *either* gluing in g handles *or* gluing in g Möbius bands. For a detailed discussion the reader may turn to Hirsch's book [H], chapter 9.

Plane models

If you find such descriptions elusive, you may find comfort in the fact that all compact surfaces can be described similarly to the way we described the torus. If we cut a hole in the torus we get a handle. This may be represented by plane models as to the right: identify the edges as indicated.

If you want more handles you just glue many of these together, so that a g -holed torus can be represented by a $4g$ -gon where two and two edges are identified (see

<http://www.it.brighton.ac.uk/staff/jt40/MapleAnimations/Torus.html>

for a nice animation of how the plane model gets glued and

<http://www.rogmann.org/math/tori/torus2en.html>

for instruction on how to sew your own two and three-holed torus).

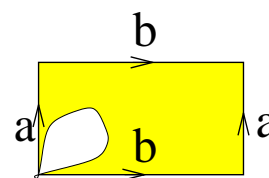
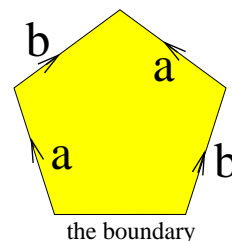

Two versions of a plane model for the handle: identify the edges as indicated to get a torus with a hole in.

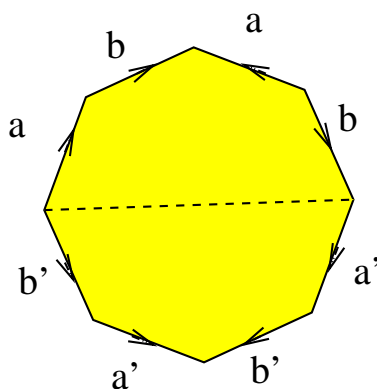

A plane model of the orientable surface of genus two. Glue corresponding edges together. The dotted line splits the surface up into two handles.

It is important to have in mind that the points on the edges in the plane models are in no way special: if we change our point of view slightly we can get them to be in the interior.

We have plane model for gluing in Möbius bands too (see picture to the right). So a surface gotten by gluing h Möbius bands to h holes on a sphere can be represented by a $2h$ -gon, where two and two edges are identified.

Example 2.2.4 If you glue two plane models of the Möbius band along their boundaries you get the picture to the right. This represent the Klein bottle, but it is not exactly the same plane representation we used earlier.

To see that the two plane models give the same surface, cut along the line c in the figure to the left below. Then take the two copies of the line a and glue them together in accordance with their orientations (this requires that you flip one of your triangles). The resulting figure which is shown to the right below, is (a rotated and slanted version of) the plane model we used before for the Klein bottle.

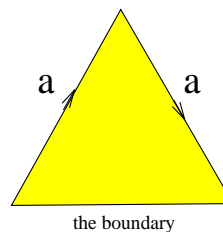

A plane model for the Möbius band: identify the edges as indicated. When gluing it onto something else, use the boundary.

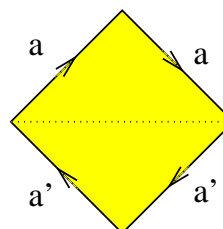

Gluing two flat Möbius bands together. The dotted line marks where the bands were glued together.

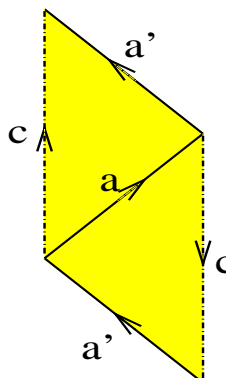
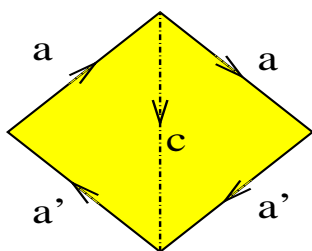

Cutting along c shows that two Möbius bands glued together is the Klein bottle.

Exercise 2.2.5 Prove by a direct cut and paste argument that what you get by adding a handle to the projective plane is the same as what you get if you add a Möbius band to the Klein bottle.

Exercise 2.2.6 Prove that the real projective plane

$$\mathbf{RP}^2 = \{\text{All lines in } \mathbf{R}^3 \text{ through the origin}\}$$

is the same as what you get by gluing a Möbius band to a sphere.

Exercise 2.2.7 See if you can find out what the “Euler number” (or “Euler characteristic”) is. Then calculate it for various surfaces using the plane models. Can you see that both the torus and the Klein bottle have Euler number zero? The sphere has Euler number 2 (which leads to the famous theorem $V - E + F = 2$ for all surfaces bounding a “ball”) and the projective plane has Euler number 1. The surface of exercise 2.2.5 has Euler number -1 . In general, adding a handle reduces the Euler number by two, and adding a Möbius band reduces it by one.

2.2.8 Higher dimensions

Although surfaces are fun and concrete, next to no real-life applications are 2-dimensional. Usually there are zillions of variables at play, and so our manifolds will be correspondingly complex. This means that we can't continue to be vague. We need strict definitions to keep track of all the structure.

However, let it be mentioned at the informal level that we must not expect to have a such a nice list of higher dimensional manifolds as we had for compact surfaces. Classification problems for higher dimensional manifolds is an extremely complex and interesting business we will not have occasion to delve into.

Chapter 3

Smooth manifolds

3.1 Topological manifolds

Let us get straight at our object of study. The terms used in the definition are explained immediately below the box. See also appendix 10 on point set topology.

Definition 3.1.1 An n -dimensional topological manifold M is
a Hausdorff topological space with a countable basis for the topology which is
locally homeomorphic to \mathbf{R}^n .

The last point (*locally homeomorphic* to \mathbf{R}^n) means that for every point $p \in M$ there is

an open neighborhood U containing p ,

an open set $U' \subseteq \mathbf{R}^n$ and

a homeomorphism $x: U \rightarrow U'$.

We call such an x a *chart*, U a *chart domain*.

A collection of charts $\{x_\alpha\}$ covering M (i.e., such that $\bigcup U_\alpha = M$) is called an *atlas*.

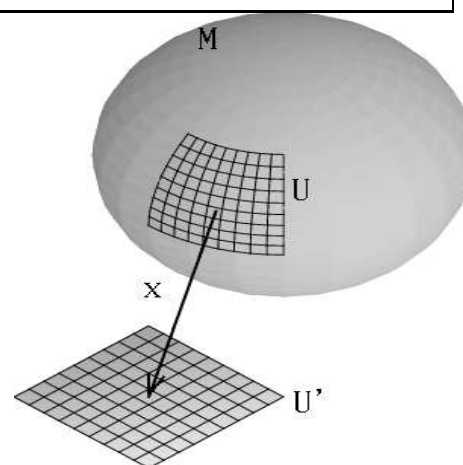

Note 3.1.2 The conditions that M should be “Hausdorff” and have a “countable basis for its topology” will not play an important rôle for us for quite a while. It is tempting to just skip these conditions, and come back to them later when they actually are important. As a matter of fact, on a first reading I suggest you actually do this. Rest assured that all

subsets of Euclidean space satisfies these conditions.

The conditions are there in order to exclude some pathological creatures that are locally homeomorphic to \mathbf{R}^n , but are so weird that we do not want to consider them. We include the conditions at once so as not to need to change our definition in the course of the book, and also to conform with usual language.

Example 3.1.3 Let $U \subseteq \mathbf{R}^n$ be an open subset. Then U is an n -manifold. Its atlas needs only have one chart, namely the identity map $id: U \rightarrow U$. As a sub-example we have the open n -disk

$$E^n = \{p \in \mathbf{R}^n \mid |p| < 1\}.$$

Example 3.1.4 The n -sphere

$$S^n = \{p \in \mathbf{R}^{n+1} \mid |p| = 1\}$$

is an n -manifold.

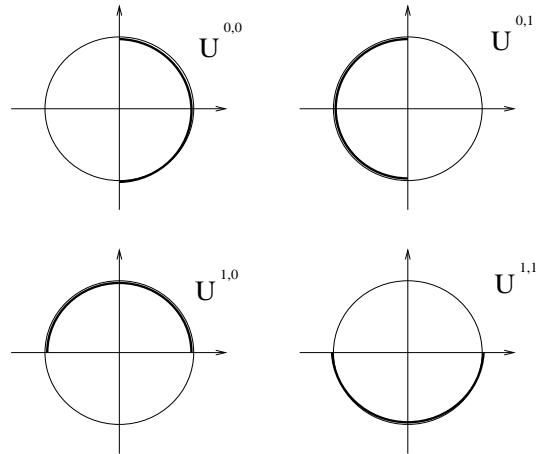

We write a point in \mathbf{R}^{n+1} as an $n + 1$ tuple as follows: $p = (p_0, p_1, \dots, p_n)$. To give an atlas for S^n , consider the open sets

$$U^{k,0} = \{p \in S^n \mid p_k > 0\},$$

$$U^{k,1} = \{p \in S^n \mid p_k < 0\}$$

for $k = 0, \dots, n$, and let

$$x^{k,i} : U^{k,i} \rightarrow E^n$$

be the projection

$$(p_0, \dots, p_n) \mapsto (p_0, \dots, \widehat{p}_k, \dots, p_n)$$

$$= (p_0, \dots, p_{k-1}, p_{k+1}, \dots, p_n)$$

(the “hat” in \widehat{p}_k is a common way to indicate that this coordinate should be deleted).

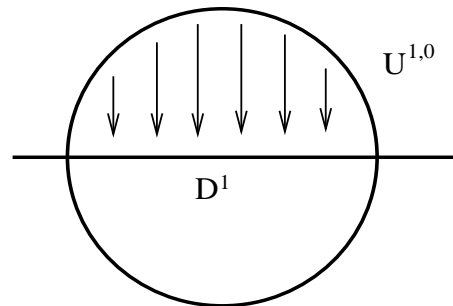

[The n -sphere is Hausdorff and has a countable basis for its topology by corollary 10.5.6 simply because it is a subspace of \mathbf{R}^{n+1} .]

Example 3.1.5 (Uses many results from the point set topology appendix). We shall later see that two charts suffice on the sphere, but it is clear that we can't make do with only one: assume there was a chart covering all of S^n . That would imply that we had a homeomorphism $x: S^n \rightarrow U'$ where U' is an open subset of \mathbf{R}^n . But this is impossible since S^n is compact (it is a bounded and closed subset of \mathbf{R}^{n+1}), and so $U' = x(S^n)$ would be compact (and nonempty), hence a closed **and** open subset of \mathbf{R}^n .

Example 3.1.6 The real projective n -space \mathbf{RP}^n is the set of all straight lines through the origin in \mathbf{R}^{n+1} . As a topological space, it is the quotient

$$\mathbf{RP}^n = (\mathbf{R}^{n+1} \setminus \{0\}) / \sim$$

where the equivalence relation is given by $p \sim q$ if there is a $\lambda \in \mathbf{R} \setminus \{0\}$ such that $p = \lambda q$. Note that this is homeomorphic to

$$S^n / \sim$$

where the equivalence relation is $p \sim -p$. The real projective n -space is an n -dimensional manifold, as we shall see below.

If $p = (p_0, \dots, p_n) \in \mathbf{R}^{n+1} \setminus \{0\}$ we write $[p]$ for its equivalence class considered as a point in \mathbf{RP}^n .

For $0 \leq k \leq n$, let

$$U^k = \{[p] \in \mathbf{RP}^n \mid p_k \neq 0\}.$$

Varying k , this gives an open cover of \mathbf{RP}^n . Note that the projection $S^n \rightarrow \mathbf{RP}^n$ when restricted to $U^{k,0} \cup U^{k,1} = \{p \in S^n \mid p_k \neq 0\}$ gives a two-to-one correspondence between $U^{k,0} \cup U^{k,1}$ and U^k . In fact, when restricted to $U^{k,0}$ the projection $S^n \rightarrow \mathbf{RP}^n$ yields a homeomorphism $U^{k,0} \cong U^k$.

The homeomorphism $U^{k,0} \cong U^k$ together with the homeomorphism

$$x^{k,0}: U^{k,0} \rightarrow E^n = \{p \in \mathbf{R}^n \mid |p| < 1\}$$

of example 3.1.4 gives a chart $U^k \rightarrow E^n$ (the explicit formula is given by sending $[p]$ to $\frac{|p_k|}{p_k|p|} (p_0, \dots, \widehat{p}_k, \dots, p_n)$). Letting k vary we get an atlas for \mathbf{RP}^n .

We can simplify this somewhat: the following atlas will be referred to as the *standard atlas* for \mathbf{RP}^n . Let

$$\begin{aligned} x^k: U^k &\rightarrow \mathbf{R}^n \\ [p] &\mapsto \frac{1}{p_k} (p_0, \dots, \widehat{p}_k, \dots, p_n) \end{aligned}$$

Note that this is a well defined (since $\frac{1}{p_k} (p_0, \dots, \widehat{p}_k, \dots, p_n) = \frac{1}{\lambda p_k} (\lambda p_0, \dots, \widehat{\lambda p_k}, \dots, \lambda p_n)$). Furthermore x^k is a bijective function with inverse given by

$$(x^k)^{-1} (p_0, \dots, \widehat{p}_k, \dots, p_n) = [p_0, \dots, 1, \dots, p_n]$$

(note the convenient cheating in indexing the points in \mathbf{R}^n).

In fact, x^k is a homeomorphism: x^k is continuous since the composite $U^{k,0} \cong U^k \rightarrow \mathbf{R}^n$ is; and $(x^k)^{-1}$ is continuous since it is the composite $\mathbf{R}^n \rightarrow \{p \in \mathbf{R}^{n+1} | p_k \neq 0\} \rightarrow U^k$ where the first map is given by $(p_0, \dots, \widehat{p}_k, \dots, p_n) \mapsto (p_0, \dots, 1, \dots, p_n)$ and the second is the projection.

[That $\mathbf{R}P^n$ is Hausdorff and has a countable basis for its topology is exercise 10.7.5.]

Note 3.1.7 It is not obvious at this point that $\mathbf{R}P^n$ can be realized as a subspace of an Euclidean space (we will show in it can in theorem 7.5.1).

Note 3.1.8 We will try to be consistent in letting the charts have names like x and y . This is sound practice since it reminds us that what charts are good for is to give “local coordinates” on our manifold: a point $p \in M$ corresponds to a point

$$x(p) = (x_1(p), \dots, x_n(p)) \in \mathbf{R}^n.$$

The general philosophy when studying manifolds is to refer back to properties of Euclidean space by means of charts. In this manner a successful theory is built up: whenever a definition is needed, we take the Euclidean version and require that the corresponding property for manifolds is the one you get by saying that it must hold true in “local coordinates”.

3.2 Smooth structures

We will have to wait until 3.3.4 for the official definition of a *smooth manifold*. The idea is simple enough: in order to do *differential* topology we need that the charts of the manifolds are glued smoothly together, so that we do not get different answers in different charts. Again “smoothly” must be borrowed from the Euclidean world. We proceed to make this precise.

Let M be a topological manifold, and let $x_1: U_1 \rightarrow U'_1$ and $x_2: U_2 \rightarrow U'_2$ be two charts on M with U'_1 and U'_2 open subsets of \mathbf{R}^n . Assume that $U_{12} = U_1 \cap U_2$ is nonempty.

Then we may define a *chart transformation*

$$x_{12}: x_1(U_{12}) \rightarrow x_2(U_{12})$$

by sending $q \in x_1(U_{12})$ to

$$x_{12}(q) = x_2 x_1^{-1}(q)$$

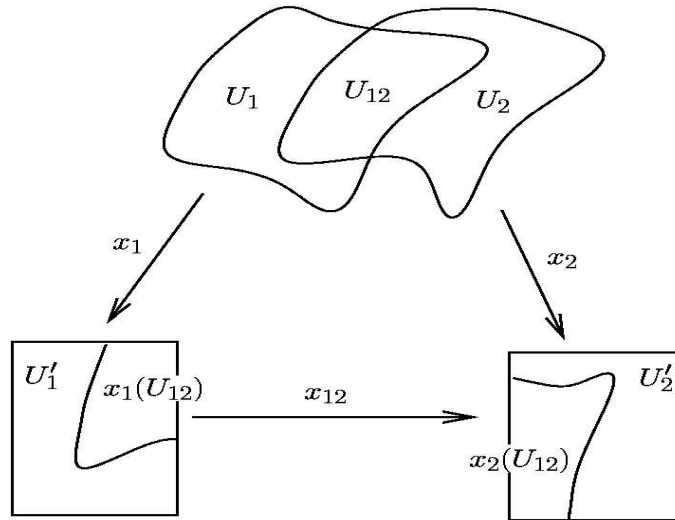

(in function notation we get that

$$x_{12} = x_2 \circ x_1^{-1}|_{x_1(U_{12})}$$

where we recall that “ $|_{x_1(U_{12})}$ ” means simply restrict the domain of definition to $x_1(U_{12})$).

This is a function from an open subset of \mathbf{R}^n to another, and it makes sense to ask whether it is smooth or not.

The picture of the chart transformation above will usually be recorded more succinctly as

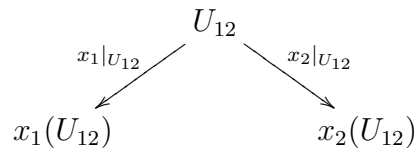

This makes things easier to remember than the occasionally awkward formulae.

Definition 3.2.1 An atlas for a manifold is *differentiable* (or *smooth*, or \mathcal{C}^∞) if all the chart transformations are differentiable (i.e., all the higher order partial derivatives exist and are continuous).

Definition 3.2.2 A smooth map f between open subsets of \mathbf{R}^n is said to be a *diffeomorphism* if it is invertible with a smooth inverse f^{-1} .

Note 3.2.3 Note that if x_{12} is a chart transformation associated to a pair of charts in an atlas, then x_{12}^{-1} is also a chart transformation. Hence, saying that an atlas is smooth is the same as saying that all the chart transformations are diffeomorphisms.

Example 3.2.4 Let $U \subseteq \mathbf{R}^n$ be an open subset. Then the atlas whose only chart is the identity $id: U \rightarrow U$ is smooth.

Example 3.2.5 The atlas

$$\mathcal{U} = \{(x^{k,i}, U^{k,i}) \mid 0 \leq k \leq n, 0 \leq i \leq 1\}$$

we gave on the n -sphere S^n is a smooth atlas. To see this, look at the example

$$x^{1,1} (x^{0,0})^{-1} \Big|_{x^{0,0}(U^{0,0} \cap U^{1,1})}$$

First we calculate the inverse: Let $p = (p_1, \dots, p_n) \in E^n$, then

$$(x^{0,0})^{-1}(p) = (\sqrt{1 - |p|^2}, p_1, \dots, p_n)$$

(the square root is positive, since we consider $x^{0,0}$). Furthermore

$$x^{0,0}(U^{0,0} \cap U^{1,1}) = \{(p_1, \dots, p_n) \in E^n \mid p_1 < 0\}$$

Finally we get that if $p \in x^{0,0}(U^{0,0} \cap U^{1,1})$ we get

$$x^{1,1} (x^{0,0})^{-1}(p) = (\sqrt{1 - |p|^2}, \hat{p}_1, p_2, \dots, p_n)$$

This is a smooth map, and generalizing to other indices we get that we have a smooth atlas for S^n .

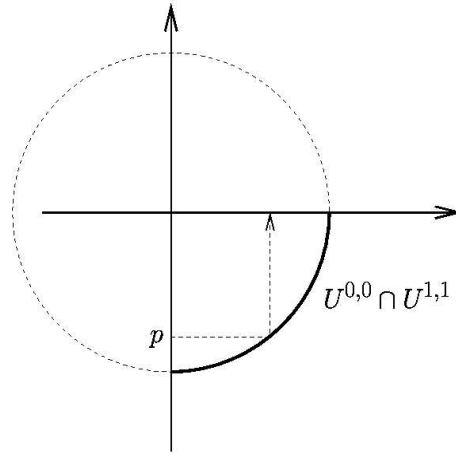

How the point p in $x^{0,0}(U^{0,0} \cap U^{1,1})$ is mapped to $x^{1,1}(x^{0,0})^{-1}(p)$.

Example 3.2.6 There is another useful smooth atlas on S^n , given by *stereographic projection*. It has only two charts.

The chart domains are

$$U^+ = \{p \in S^n \mid p_0 > -1\}$$

$$U^- = \{p \in S^n \mid p_0 < 1\}$$

and x^+ is given by sending a point on S^n to the intersection of the plane

$$\mathbf{R}^n = \{(0, p_1, \dots, p_n) \in \mathbf{R}^{n+1}\}$$

and the straight line through the South pole $S = (-1, 0, \dots, 0)$ and the point.

Similarly for x^- , using the North pole instead. Note that both maps are homeomorphisms onto all of \mathbf{R}^n

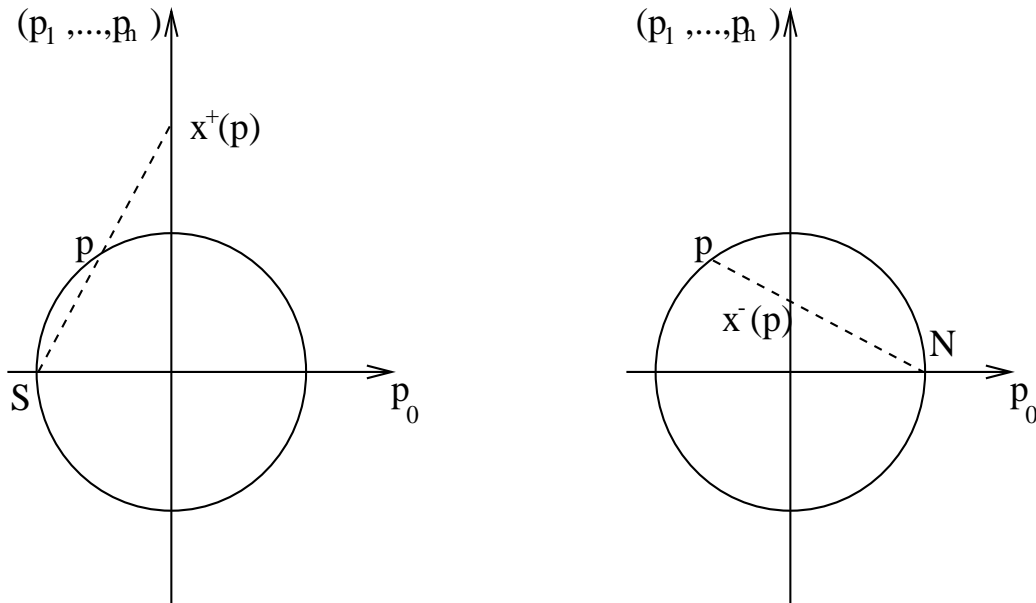

To check that there are no unpleasant surprises, one should write down the formulas:

$$x^+(p) = \frac{1}{1 + p_0}(p_1, \dots, p_n)$$

$$x^-(p) = \frac{1}{1 - p_0}(p_1, \dots, p_n)$$

We need to check that the chart transformations are smooth. Consider the chart transformation $x^+(x^-)^{-1}$ defined on $x^-(U^- \cap U^+) = \mathbf{R}^n \setminus \{0\}$. A small calculation yields that if $q = (q_1, \dots, q_n) \in \mathbf{R}^n \setminus \{0\}$ then

$$(x^-)^{-1}(q) = \frac{1}{1 + |q|^2}(|q|^2 - 1, 2q)$$

(solve the equation $x^-(p) = q$ with respect to p), and so

$$x^+(x^-)^{-1}(q) = \frac{1}{|q|^2}q$$

which is smooth. Similar calculations for the other chart transformations yield that this is a smooth atlas.

Exercise 3.2.7 Check that the formulae in the stereographic projection example are correct.

Note 3.2.8 The last two examples may be somewhat worrisome: the sphere is the sphere, and these two atlases are two manifestations of the “same” sphere, are they not? We

address this kind of questions in the next chapter: “when do two different atlases describe the same smooth manifold?” You should, however, be aware that there **are** “exotic” smooth structures on spheres, i.e., smooth atlases on the topological manifold S^n which describe smooth structures essentially different from the one(s?) we have described (but only in dimensions greater than six). Furthermore, there are topological manifolds which can not be given smooth atlases.

Example 3.2.9 The atlas we gave the real projective space was smooth. As an example consider the chart transformation $x^2 (x^0)^{-1}$: if $p_2 \neq 0$ then

$$x^1 (x^0)^{-1} (p_1, \dots, p_n) = \frac{1}{p_2} (1, p_1, p_3, \dots, p_n)$$

Exercise 3.2.10 Show in all detail that the complex projective n -space

$$\mathbf{CP}^n = (\mathbf{C}^{n+1} \setminus \{0\}) / \sim$$

where $z \sim w$ if there exists a $\lambda \in \mathbf{C} \setminus \{0\}$ such that $z = \lambda w$, is a $2n$ -dimensional manifold.

Exercise 3.2.11 Give the boundary of the square the structure of a smooth manifold.

3.3 Maximal atlases

We easily see that some manifolds can be equipped with many different smooth atlases. An example is the circle. Stereographic projection gives a different atlas than what you get if you for instance parameterize by means of the angle. But we do not want to distinguish between these two “smooth structures”, and in order to systematize this we introduce the concept of a *maximal atlas*.

Assume we have a manifold M together with a smooth atlas \mathcal{U} on M .

Definition 3.3.1 Let M be a manifold and \mathcal{U} a smooth atlas on M . Then we define $\mathcal{D}(\mathcal{U})$ as the following set of charts on M :

$$\mathcal{D}(\mathcal{U}) = \left\{ \text{charts } y: V \rightarrow V' \text{ on } M \left| \begin{array}{l} \text{for all charts} \\ x: U \rightarrow U' \text{ in } \mathcal{U} \\ \text{the maps} \\ x \circ y^{-1}|_{y(U \cap V)} \\ y \circ x^{-1}|_{x(U \cap V)} \\ \text{are smooth} \end{array} \right. \text{ and } \right\}$$

Lemma 3.3.2 Let M be a manifold and \mathcal{U} a smooth atlas on M . Then $\mathcal{D}(\mathcal{U})$ is a differentiable atlas.

Proof: Let $y: V \rightarrow V'$ and $z: W \rightarrow W'$ be two charts in $\mathcal{D}(\mathcal{U})$. We have to show that

$$z \circ y^{-1}|_{y(V \cap W)}$$

is differentiable. Let q be any point in $y(V \cap W)$. We prove that $z \circ y^{-1}$ is differentiable in a neighborhood of q . Choose a chart $x: U \rightarrow U'$ in \mathcal{U} with $y^{-1}(q) \in U$.

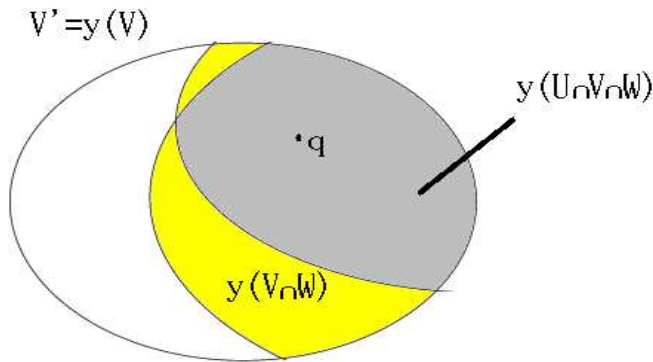

We get that

$$\begin{aligned} z \circ y^{-1}|_{y(U \cap V \cap W)} &= z \circ (x^{-1} \circ x) \circ y^{-1}|_{y(U \cap V \cap W)} \\ &= (z \circ x^{-1})_{x(U \cap V \cap W)} \circ (x \circ y^{-1})|_{y(U \cap V \cap W)} \end{aligned}$$

Since y and z are in $\mathcal{D}(\mathcal{U})$ and x is in \mathcal{U} we have by definition that both the maps in the composite above are differentiable, and we are done. \square

The crucial equation can be visualized by the following diagram

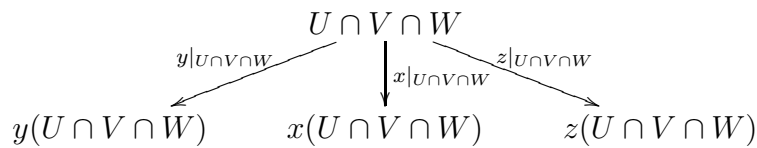

Going up and down with $x|_{U \cap V \cap W}$ in the middle leaves everything fixed so the two functions from $y(U \cap V \cap W)$ to $z(U \cap V \cap W)$ are equal.

Note 3.3.3 A differential atlas is *maximal* if there is no strictly bigger differentiable atlas containing it. We observe that $\mathcal{D}(\mathcal{U})$ is maximal in this sense; in fact if \mathcal{V} is any differential atlas containing \mathcal{U} , then $\mathcal{V} \subseteq \mathcal{D}(\mathcal{U})$, and so $\mathcal{D}(\mathcal{U}) = \mathcal{D}(\mathcal{V})$. Hence any differential atlas is a subset of a unique maximal differential atlas.

Definition 3.3.4 A *smooth structure* on a topological manifold is a maximal smooth atlas. A *smooth manifold* (M, \mathcal{U}) is a topological manifold M equipped with a smooth structure \mathcal{U} . A *differentiable manifold* is a topological manifold for which there exist differential structures.

Note 3.3.5 The following words are synonymous: smooth, differential and \mathcal{C}^∞ .

Note 3.3.6 In practice we do not give the maximal atlas, but only a small practical smooth atlas and apply \mathcal{D} to it. Often we write just M instead of (M, \mathcal{U}) if \mathcal{U} is clear from the context.

Exercise 3.3.7 Show that the two smooth structures we have defined on S^n are contained in a common maximal atlas. Hence they define the same smooth manifold, which we will simply call the (*standard smooth*) *sphere*.

Exercise 3.3.8 Choose your favorite diffeomorphism $x: \mathbf{R}^n \rightarrow \mathbf{R}^n$. Why is the smooth structure generated by x equal to the smooth structure generated by the identity? What does the maximal atlas for this smooth structure (the only one we'll ever consider) on \mathbf{R}^n look like?

Note 3.3.9 You may be worried about the fact that maximal atlases are frightfully big. If so, you may find some consolation in the fact that any smooth manifold (M, \mathcal{U}) has a countable smooth atlas determining its smooth structure. This will be discussed more closely in lemma 7.3.1, but for the impatient it can be seen as follows: since M is a topological manifold it has a countable basis \mathcal{B} for its topology. For each $(x, U) \in \mathcal{U}$ with $E^n \subseteq x(U)$ choose a $V \in \mathcal{B}$ such that $V \subseteq x^{-1}(E^n)$. The set \mathcal{A} of such sets V is a countable subset of \mathcal{B} , and \mathcal{A} covers M , since around any point on M there is a chart containing E^n in its image (choose any chart (x, U) containing your point p . Then $x(U)$, being open, contains **some** small ball. Restrict to this, and reparameterize so that it becomes the unit ball). Now, for every $V \in \mathcal{A}$ choose **one** of the charts $(x, U) \in \mathcal{U}$ with $E^n \subseteq x(U)$ such that $V \subseteq x^{-1}(E^n)$. The resulting set $\mathcal{V} \subseteq \mathcal{U}$ is then a countable smooth atlas for (M, \mathcal{U}) .

3.4 Smooth maps

Having defined smooth manifolds, we need to define smooth maps between them. No surprise: smoothness is a local question, so we may fetch the notion from Euclidean space by means of charts.

Definition 3.4.1 Let (M, \mathcal{U}) and (N, \mathcal{V}) be smooth manifolds and $p \in M$. A continuous map $f: M \rightarrow N$ is *smooth at p* (or *differentiable at p*) if for any chart $x: U \rightarrow U' \in \mathcal{U}$ with $p \in U$ and any chart $y: V \rightarrow V' \in \mathcal{V}$ with $f(p) \in V$ the map

$$y \circ f \circ x^{-1}|_{x(U \cap f^{-1}(V))}: x(U \cap f^{-1}(V)) \rightarrow V'$$

is differentiable at $x(p)$.

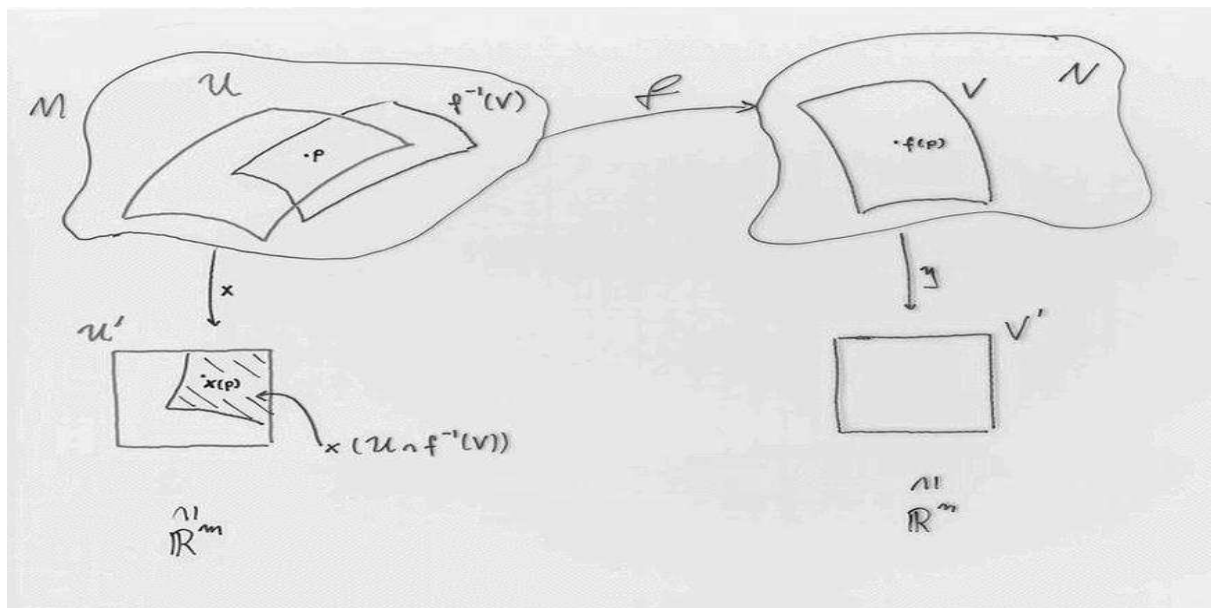

We say that f is a *smooth map* if it is smooth at all points of M .

The picture above will often find a less typographically challenging expression: “go up, over and down in the picture

$$\begin{array}{ccc} W & \xrightarrow{f|_W} & V \\ x|_W \downarrow & & y \downarrow \\ x(W) & & V' \end{array}$$

where $W = U \cap f^{-1}(V)$, and see whether you have a smooth map of open subsets of Euclidean spaces”. Note that $x(U \cap f^{-1}(V)) = U' \cap x(f^{-1}(V))$.

Exercise 3.4.2 The map $\mathbf{R} \rightarrow S^1$ sending $p \in \mathbf{R}$ to $e^{ip} = (\cos p, \sin p) \in S^1$ is smooth.

Exercise 3.4.3 Show that the map $g: \mathbf{S}^2 \rightarrow \mathbf{R}^4$ given by

$$g(p_0, p_1, p_2) = (p_1 p_2, p_0 p_2, p_0 p_1, p_0^2 + 2p_1^2 + 3p_2^2)$$

defines a smooth injective map

$$\tilde{g}: \mathbf{RP}^2 \rightarrow \mathbf{R}^4$$

via the formula $\tilde{g}([p]) = g(p)$.

Exercise 3.4.4 Show that a map $\mathbf{RP}^n \rightarrow M$ is smooth iff the composite

$$S^n \rightarrow \mathbf{RP}^n \rightarrow M$$

is smooth.

Definition 3.4.5 A smooth map $f: M \rightarrow N$ is a *diffeomorphism* if it is a bijection, and the inverse is smooth too. Two smooth manifolds are *diffeomorphic* if there exists a diffeomorphism between them.

Note 3.4.6 Note that this use of the word diffeomorphism coincides with the one used earlier in the flat (open subsets of \mathbf{R}^n) case.

Example 3.4.7 The smooth map $\mathbf{R} \rightarrow \mathbf{R}$ sending $p \in \mathbf{R}$ to p^3 is a smooth homeomorphism, but it is not a diffeomorphism: the inverse is not smooth at $0 \in \mathbf{R}$.

Example 3.4.8 Note that

$$\tan: (-\pi/2, \pi/2) \rightarrow \mathbf{R}$$

is a diffeomorphism (and hence all open intervals are diffeomorphic to the entire real line).

Note 3.4.9 To see whether f in the definition 3.4.1 above is smooth at $p \in M$ you do not actually have to check **all** charts! We do not even need to know that it is continuous! We formulate this as a lemma: its proof can be viewed as a worked exercise.

Lemma 3.4.10 Let (M, \mathcal{U}) and (N, \mathcal{V}) be smooth manifolds. A function $f: M \rightarrow N$ is smooth at $p \in M$ if and only if there exist charts $x: U \rightarrow U' \in \mathcal{U}$ and $y: V \rightarrow V' \in \mathcal{V}$ with $p \in U$ and $f(p) \in V$ such that the map

$$y \circ f \circ x^{-1}|_{x(U \cap f^{-1}(V))}: x(U \cap f^{-1}(V)) \rightarrow V'$$

is differentiable at $x(p)$.

Proof: The function f is continuous since $y \circ f \circ x^{-1}|_{x(U \cap f^{-1}(V))}$ is smooth (and so continuous), and x and y are homeomorphisms.

Given any **other** charts X and Y we get that

$$Y \circ f \circ X^{-1}(q) = (Y \circ y^{-1}) \circ (y \circ f \circ x^{-1}) \circ (x \circ X^{-1})(q)$$

for all q close to p , and this composite is smooth since \mathcal{V} and \mathcal{U} are smooth. \square

Exercise 3.4.11 Show that \mathbf{RP}^1 and S^1 are diffeomorphic.

Lemma 3.4.12 *If $f: (M, \mathcal{U}) \rightarrow (N, \mathcal{V})$ and $g: (N, \mathcal{V}) \rightarrow (P, \mathcal{W})$ are smooth, then the composite $gf: (M, \mathcal{U}) \rightarrow (P, \mathcal{W})$ is smooth too.*

Proof: This is true for maps between Euclidean spaces, and we lift this fact to smooth manifolds. Let $p \in M$ and choose appropriate charts

$$x: U \rightarrow U' \in \mathcal{U}, \text{ such that } p \in U,$$

$$y: V \rightarrow V' \in \mathcal{V}, \text{ such that } f(p) \in V,$$

$$z: W \rightarrow W' \in \mathcal{W}, \text{ such that } gf(p) \in W.$$

Then $T = U \cap f^{-1}(V \cap g^{-1}(W))$ is an open set containing p , and we have that

$$zgf x^{-1}|_{x(T)} = (zgy^{-1})(yfx^{-1})|_{x(T)}$$

which is a composite of smooth maps of Euclidean spaces, and hence smooth. \square

In a picture, if $S = V \cap g^{-1}(W)$ and $T = U \cap f^{-1}(S)$:

$$\begin{array}{ccccc} T & \xrightarrow{f|_T} & S & \xrightarrow{g|_S} & W \\ \downarrow x|_T & & \downarrow y|_S & & \downarrow z|_W \\ x(T) & & y(S) & & z(W) \end{array}$$

Going up and down with y does not matter.

Exercise 3.4.13 Let $f: M \rightarrow N$ be a homeomorphism of topological spaces. If M is a smooth manifold then there is a unique smooth structure on N that makes f a diffeomorphism.

Definition 3.4.14 Let (M, \mathcal{U}) and (N, \mathcal{V}) be smooth manifolds. Then we let

$$\mathcal{C}^\infty(M, N) = \{\text{smooth maps } M \rightarrow N\}$$

and

$$\mathcal{C}^\infty(M) = \mathcal{C}^\infty(M, \mathbf{R}).$$

Note 3.4.15 A small digression, which may be disregarded by the categorically illiterate. The outcome of the discussion above is that we have a category \mathcal{C}^∞ of smooth manifolds: the objects are the smooth manifolds, and if M and N are smooth, then

$$\mathcal{C}^\infty(M, N)$$

is the set of morphisms. The statement that \mathcal{C}^∞ is a category uses that the identity map is smooth (check), and that the composition of smooth functions is smooth, giving the composition in \mathcal{C}^∞ :

$$\mathcal{C}^\infty(N, P) \times \mathcal{C}^\infty(M, N) \rightarrow \mathcal{C}^\infty(M, P)$$

The diffeomorphisms are the isomorphisms in this category.

Definition 3.4.16 A smooth map $f: M \rightarrow N$ is a *local diffeomorphism* if for each $p \in M$ there is an open set $U \subseteq M$ containing p such that $f(U)$ is an open subset of N and

$$f|_U: U \rightarrow f(U)$$

is a diffeomorphism.

Example 3.4.17 The projection $S^n \rightarrow \mathbf{R}P^n$ is a local diffeomorphism.

Here is a more general example: let M be a smooth manifold, and

$$i: M \rightarrow M$$

a diffeomorphism with the property that $i(p) \neq p$, but $i(i(p)) = p$ for all $p \in M$ (such an animal is called a *fixed point free involution*).

The quotient space M/i gotten by identifying p and $i(p)$ has a smooth structure, such that the projection $f: M \rightarrow M/i$ is a local diffeomorphism.

We leave the proof of this claim as an exercise:

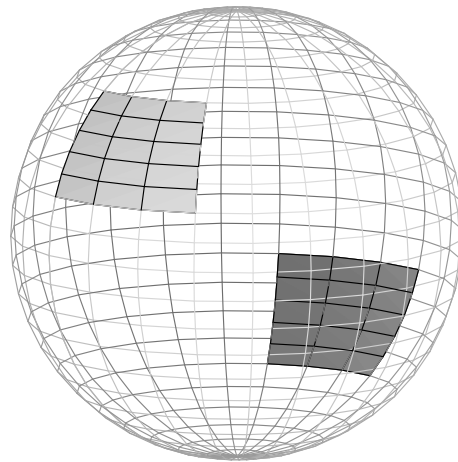

Small open sets in $\mathbf{R}P^2$ correspond to unions $U \cup (-U)$ where $U \subseteq S^2$ is an open set totally contained in one hemisphere.

Exercise 3.4.18 Show that M/i has a smooth structure such that the projection $f: M \rightarrow M/i$ is a local diffeomorphism.

Exercise 3.4.19 If (M, \mathcal{U}) is a smooth n -dimensional manifold and $p \in M$, then there is a chart $x: U \rightarrow \mathbf{R}^n$ such that $x(p) = 0$.

Note 3.4.20 In differential topology we consider two smooth manifolds to be the same if they are diffeomorphic, and all properties one studies are unaffected by diffeomorphisms.

The circle is the only compact connected smooth 1-manifold.

In dimension two it is only slightly more interesting. As we discussed in 2.2.3, you can obtain any compact (smooth) connected 2-manifold by punching g holes in the sphere S^2 and glue onto this either g handles or g Möbius bands.

In dimension three and up total chaos reigns (and so it is here all the interesting stuff is). Well, actually only the part within the parentheses is true in the last sentence: there is a lot of structure, much of it well understood. However all of it is beyond the scope of these notes. It involves quite a lot of manifold theory, but also algebraic topology and a subject called surgery which in spirit is not so distant from the cutting and pasting techniques we used on surfaces in 2.2.3.

3.5 Submanifolds

We give a slightly unorthodox definition of submanifolds. The “real” definition will appear only very much later, and then in the form of a theorem! This approach makes it possible to discuss this important concept before we have developed the proper machinery to express the “real” definition. (This is really not all that unorthodox, since it is done in the same way in for instance both [BJ] and [H]).

Definition 3.5.1 Let (M, \mathcal{U}) be a smooth $n + k$ -dimensional smooth manifold.

An n -dimensional (smooth) submanifold in M is a subset $N \subseteq M$ such that for each $p \in N$ there is a chart $x: U \rightarrow U'$ in \mathcal{U} with $p \in U$ such that

$$x(U \cap N) = U' \cap \mathbf{R}^n \times \{0\} \subseteq \mathbf{R}^n \times \mathbf{R}^k.$$

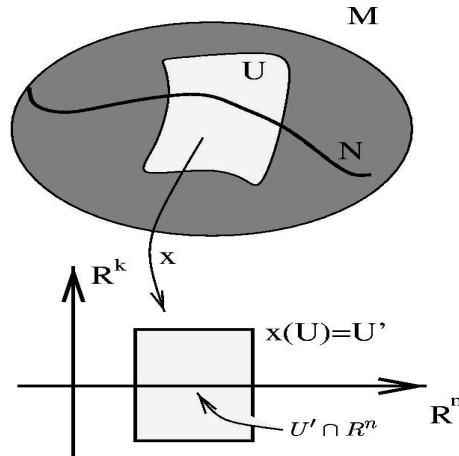

In this definition we identify \mathbf{R}^{n+k} with $\mathbf{R}^n \times \mathbf{R}^k$. We often write $\mathbf{R}^n \subseteq \mathbf{R}^n \times \mathbf{R}^k$ instead of $\mathbf{R}^n \times \{0\} \subseteq \mathbf{R}^n \times \mathbf{R}^k$ to signify the subset of all points with the k last coordinates equal to zero.

Note 3.5.2 The language of the definition really makes some sense: if (M, \mathcal{U}) is a smooth manifold and $N \subseteq M$ a submanifold, then we give N the smooth structure

$$\mathcal{U}|_N = \{(x|_{U \cap N}, U \cap N) | (x, U) \in \mathcal{U}\}$$

Note that the inclusion $N \rightarrow M$ is smooth.

Example 3.5.3 Let n be a natural number. Then $K_n = \{(p, p^n)\} \subseteq \mathbf{R}^2$ is a differentiable submanifold.

We define a differentiable chart

$$x : \mathbf{R}^2 \rightarrow \mathbf{R}^2, \quad (p, q) \mapsto (p, q - p^n)$$

Note that as required, x is smooth with smooth inverse given by

$$(p, q) \mapsto (p, q + p^n)$$

and that $x(K_n) = \mathbf{R}^1 \times \{0\}$.

Exercise 3.5.4 Prove that $S^1 \subset \mathbf{R}^2$ is a submanifold. More generally: prove that $S^n \subset \mathbf{R}^{n+1}$ is a submanifold.

Example 3.5.5 Consider the subset $C \subseteq \mathbf{R}^{n+1}$ given by

$$C = \{(a_0, \dots, a_{n-1}, t) \in \mathbf{R}^{n+1} \mid t^n + a_{n-1}t^{n-1} + \dots + a_1t + a_0 = 0\}$$

a part of which is illustrated for $n = 2$ in the picture below.

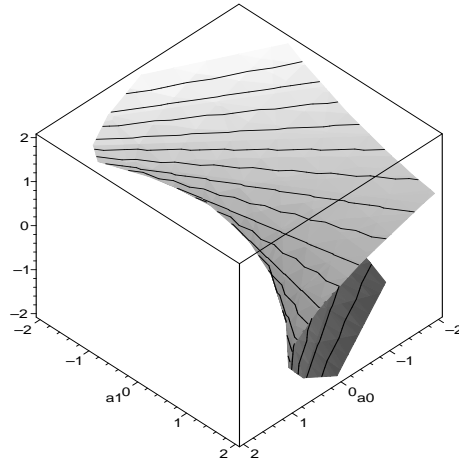

We see that C is a submanifold as follows. Consider the chart $x : \mathbf{R}^{n+1} \rightarrow \mathbf{R}^{n+1}$ given by

$$x(a_0, \dots, a_{n-1}, t) = (a_0 - (t^n + a_{n-1}t^{n-1} + \dots + a_1t), a_1, \dots, a_{n-1}, t)$$

This is a smooth chart on \mathbf{R}^{n+1} since x is a diffeomorphism with inverse

$$x^{-1}(b_0, \dots, b_{n-1}, t) = (t^n + b_{n-1}t^{n-1} + \dots + b_1t + b_0, b_1, \dots, b_{n-1}, t)$$

and we see that $C = x(0 \times \mathbf{R}^n)$. Permuting the coordinates (which also is a smooth chart) we have shown that C is an n -dimensional submanifold.

Exercise 3.5.6 The subset $K = \{(p, |p|) \mid p \in \mathbf{R}\} \subseteq \mathbf{R}^2$ is **not** a differentiable submanifold.

Note 3.5.7 If $\dim(M) = \dim(N)$ then $N \subset M$ is an open subset (called an *open submanifold*). Otherwise $\dim(M) > \dim(N)$.

Example 3.5.8 Let $M_n\mathbf{R}$ be the set of $n \times n$ matrices. This is a smooth manifold since it is homeomorphic to \mathbf{R}^{n^2} . The subset $\mathrm{GL}_n(\mathbf{R}) \subseteq M_n\mathbf{R}$ of invertible matrices is an open submanifold. (since the determinant function is continuous, so the inverse image of the open set $\mathbf{R} \setminus \{0\}$ is open)

Example 3.5.9 Let $M_{m \times n}\mathbf{R}$ be the set of $m \times n$ matrices. This is a smooth manifold since it is homeomorphic to \mathbf{R}^{mn} . Then the subset $M_{m \times n}^r(\mathbf{R}) \subseteq M_{m \times n}\mathbf{R}$ of rank r matrices is a submanifold of codimension $(n-r)(m-r)$.

That a matrix has rank r means that it has an $r \times r$ invertible submatrix, but no larger invertible submatrices. For the sake of simplicity, we cover the case where our matrices have an invertible $r \times r$ submatrices in the upper left-hand corner. The other cases are covered in a similar manner, taking care of indices.

So, consider the open set U of matrices

$$X = \begin{bmatrix} A & B \\ C & D \end{bmatrix}$$

with $A \in M_r(\mathbf{R})$, $B \in M_{r \times (n-r)}(\mathbf{R})$, $C \in M_{(m-r) \times r}(\mathbf{R})$ and $D \in M_{(m-r) \times (n-r)}(\mathbf{R})$ such that $\det(A) \neq 0$. The matrix X has rank exactly r if and only if the last $n-r$ columns are in the span of the first r . Writing this out, this means that X is of rank r if and only if there is an $r \times (n-r)$ -matrix T such that

$$\begin{bmatrix} B \\ D \end{bmatrix} = \begin{bmatrix} A \\ C \end{bmatrix} T$$

which is equivalent to $T = A^{-1}B$ and $D = CA^{-1}B$. Hence

$$U \cap M_{m \times n}^r(\mathbf{R}) = \left\{ \begin{bmatrix} A & B \\ C & D \end{bmatrix} \in U \mid D - CA^{-1}B = 0 \right\}.$$

The map

$$\begin{aligned} U &\rightarrow \mathbf{R}^{mn} \cong \mathbf{R}^{rr} \times \mathbf{R}^{r(n-r)} \times \mathbf{R}^{(m-r)r} \times \mathbf{R}^{(m-r)(n-r)} \\ \begin{bmatrix} A & B \\ C & D \end{bmatrix} &\mapsto (A, B, C, D - CA^{-1}B) \end{aligned}$$

is a local diffeomorphism, and therefore a chart having the desired property that $U \cap M_{m \times n}^r(\mathbf{R})$ is the set of points such that the last $(m-r)(n-r)$ coordinates vanish.

Definition 3.5.10 A smooth map $f: N \rightarrow M$ is an *imbedding* if

the image $f(N) \subseteq M$ is a submanifold, and

the induced map

$$N \rightarrow f(N)$$

is a diffeomorphism.

Exercise 3.5.11 The map

$$f: \mathbf{RP}^n \rightarrow \mathbf{RP}^{n+1}$$

$$[p] = [p_0, \dots, p_n] \mapsto [p, 0] = [p_0, \dots, p_n, 0]$$

is an imbedding.

Note 3.5.12 Later we will give a very efficient way of creating smooth submanifolds, getting rid of all the troubles of finding actual charts that make the subset look like \mathbf{R}^n in \mathbf{R}^{n+k} . We shall see that if $f: M \rightarrow N$ is a smooth map and $q \in N$ then more often than not the inverse image

$$f^{-1}(q) = \{p \in M \mid f(p) = q\}$$

is a submanifold of M . Examples of such submanifolds are the sphere and the space of orthogonal matrices (the inverse image of the identity matrix under the map sending a matrix A to $A^t A$).

Example 3.5.13 An example where we have the opportunity to use a bit of topology. Let $f: M \rightarrow N$ be an imbedding, where M is a (non-empty) compact n -dimensional smooth manifold and N is a connected n -dimensional smooth manifold. Then f is a diffeomorphism. This is so because $f(M)$ is compact, and hence closed, and open since it is a codimension zero submanifold. Hence $f(M) = N$ since N is connected. But since f is an imbedding, the map $M \rightarrow f(M) = N$ is – by definition – a diffeomorphism.

Exercise 3.5.14 (important exercise. Do it: you will need the result several times). Let $i_1: N_1 \rightarrow M_1$ and $i_2: N_2 \rightarrow M_2$ be smooth imbeddings and let $f: N_1 \rightarrow N_2$ and $g: M_1 \rightarrow M_2$ be continuous maps such that $i_2 f = g i_1$ (i.e., the diagram

$$\begin{array}{ccc} N_1 & \xrightarrow{f} & N_2 \\ i_1 \downarrow & & i_2 \downarrow \\ M_1 & \xrightarrow{g} & M_2 \end{array}$$

commutes). Show that if g is smooth, then f is smooth.

3.6 Products and sums

Definition 3.6.1 Let (M, \mathcal{U}) and (N, \mathcal{V}) be smooth manifolds. The (*smooth*) *product* is the smooth manifold you get by giving the product $M \times N$ the smooth structure given by the charts

$$\begin{aligned} x \times y: U \times V &\rightarrow U' \times V' \\ (p, q) &\mapsto (x(p), y(q)) \end{aligned}$$

where $(x, U) \in \mathcal{U}$ and $(y, V) \in \mathcal{V}$.

Exercise 3.6.2 Check that this definition makes sense.

Note 3.6.3 The atlas we give the product is not maximal.

Example 3.6.4 We know a product manifold already: the *torus* $S^1 \times S^1$.

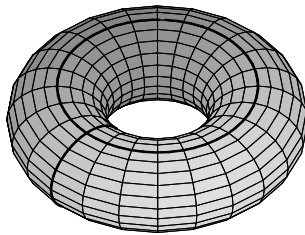

The torus is a product. The bolder curves in the illustration try to indicate the submanifolds $\{1\} \times S^1$ and $S^1 \times \{1\}$.

Exercise 3.6.5 Show that the projection

$$\begin{aligned} pr_1: M \times N &\rightarrow M \\ (p, q) &\mapsto p \end{aligned}$$

is a smooth map. Choose a point $p \in M$. Show that the map

$$\begin{aligned} i_p: N &\rightarrow M \times N \\ q &\mapsto (p, q) \end{aligned}$$

is an imbedding.

Exercise 3.6.6 Show that giving a smooth map $Z \rightarrow M \times N$ is the same as giving a pair of smooth maps $Z \rightarrow M$ and $Z \rightarrow N$. Hence we have a bijection

$$\mathcal{C}^\infty(Z, M \times N) \cong \mathcal{C}^\infty(Z, M) \times \mathcal{C}^\infty(Z, N).$$

Exercise 3.6.7 Show that the infinite cylinder $\mathbf{R}^1 \times S^1$ is diffeomorphic to $\mathbf{R}^2 \setminus \{0\}$.

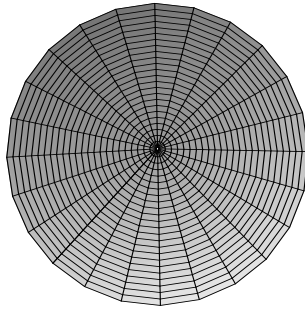

Looking down into the infinite cylinder.

More generally: $\mathbf{R}^1 \times S^n$ is diffeomorphic to $\mathbf{R}^{n+1} \setminus \{0\}$.

Exercise 3.6.8 Let $f: M \rightarrow M'$ and $g: N \rightarrow N'$ be imbeddings. Then

$$f \times g: M \times N \rightarrow M' \times N'$$

is an imbedding.

Exercise 3.6.9 Let $M = S^{n_1} \times \cdots \times S^{n_k}$. Show that there exists an imbedding $M \rightarrow \mathbf{R}^N$ where $N = 1 + \sum_{i=1}^k n_i$

Exercise 3.6.10 Why is the multiplication of matrices

$$\mathrm{GL}_n(\mathbf{R}) \times \mathrm{GL}_n(\mathbf{R}) \rightarrow \mathrm{GL}_n(\mathbf{R}), \quad (A, B) \mapsto A \cdot B$$

a smooth map? This, together with the existence of inverses, makes $\mathrm{GL}_n(\mathbf{R})$ a “Lie group”.

Exercise 3.6.11 Why is the multiplication

$$S^1 \times S^1 \rightarrow S^1, \quad (e^{i\theta}, e^{i\tau}) \mapsto e^{i\theta} \cdot e^{i\tau} = e^{i(\theta+\tau)}$$

a smooth map? This is our second example of a Lie Group.

Definition 3.6.12 Let (M, \mathcal{U}) and (N, \mathcal{V}) be smooth manifolds. The (smooth) disjoint union (or sum) is the smooth manifold you get by giving the disjoint union $M \coprod N$ the smooth structure given by $\mathcal{U} \cup \mathcal{V}$.

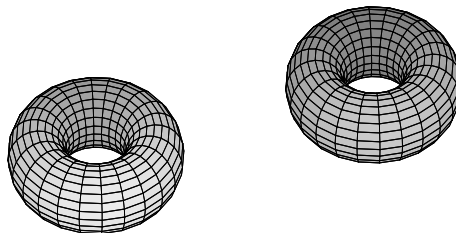

The disjoint union of two tori (imbedded in \mathbf{R}^3).

Exercise 3.6.13 Check that this definition makes sense.

Note 3.6.14 The atlas we give the sum is not maximal.

Example 3.6.15 The Borromean rings gives an interesting example showing that the imbedding in Euclidean space is irrelevant to the manifold: the borromean rings is the disjoint union of three circles $S^1 \amalg S^1 \amalg S^1$. Don't get confused: it is the imbedding in \mathbf{R}^3 that makes your mind spin: the manifold itself is just three copies of the circle! Morale: an imbedded manifold is something more than just a manifold that *can be* imbedded.

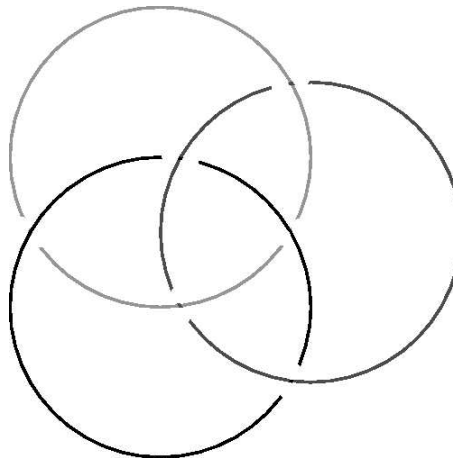

Exercise 3.6.16 Prove that the inclusion

$$inc_1: M \subset M \amalg N$$

is an imbedding.

Exercise 3.6.17 Show that giving a smooth map $M \amalg N \rightarrow Z$ is the same as giving a pair of smooth maps $M \rightarrow Z$ and $N \rightarrow Z$. Hence we have a bijection

$$\mathcal{C}^\infty(M \amalg N, Z) \cong \mathcal{C}^\infty(M, Z) \times \mathcal{C}^\infty(N, Z).$$

Chapter 4

The tangent space

Given a submanifold M of \mathbf{R}^n , it is fairly obvious what we should mean by the “tangent space” of M at a point $p \in M$.

In purely physical terms, the tangent space should be the following subspace of \mathbf{R}^n : If a particle moves on some curve in M and at p suddenly “looses the grip on M ” it will continue out in the ambient space along a straight line (its “tangent”). Its path is determined by its velocity vector at the point where it flies out into space. The tangent space should be the linear subspace of \mathbf{R}^n containing all these vectors.

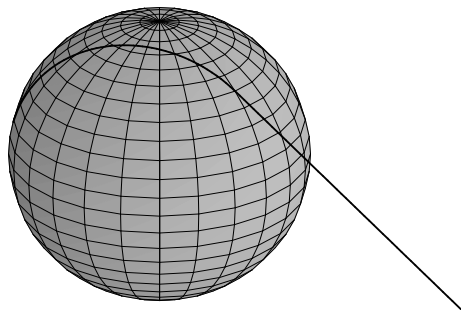

A particle loses its grip on M and flies out on a tangent

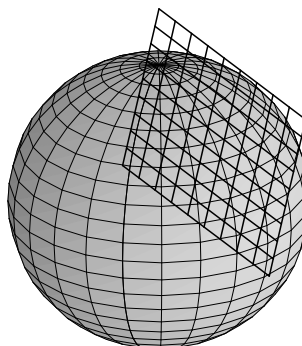

A part of the space of all tangents

When talking about manifolds it is important to remember that there **is no** ambient space to fly out into, but we still may talk about a tangent space.

4.0.1 Predefinition of the tangent space

Let M be a differentiable manifold, and let $p \in M$. Consider the set of all curves

$$\gamma: (-\epsilon, \epsilon) \rightarrow M$$

with $\gamma(0) = p$. On this set we define the following equivalence relation: given two curves $\gamma: (-\epsilon, \epsilon) \rightarrow M$ and $\gamma_1: (-\epsilon_1, \epsilon_1) \rightarrow M$ with $\gamma(0) = \gamma_1(0) = p$ we say that γ and γ_1 are equivalent if for all charts $x: U \rightarrow U'$ with $p \in U$

$$(x\gamma)'(0) = (x\gamma_1)'(0)$$

Then the tangent space of M at p is the set of all equivalence classes.

There is nothing wrong with this definition, in the sense that it is naturally isomorphic to the one we are going to give in a short while. But in order to work efficiently with our tangent space, it is fruitful to introduce some language.

4.1 Germs

Whatever one's point of view on tangent vectors are, it is a local concept. The tangent of a curve passing through a given point p is only dependent upon the behavior of the curve close to the point. Hence it makes sense to divide out by the equivalence relation which says that all curves that are equal on some neighborhood of the point are equivalent. This is the concept of *germs*.

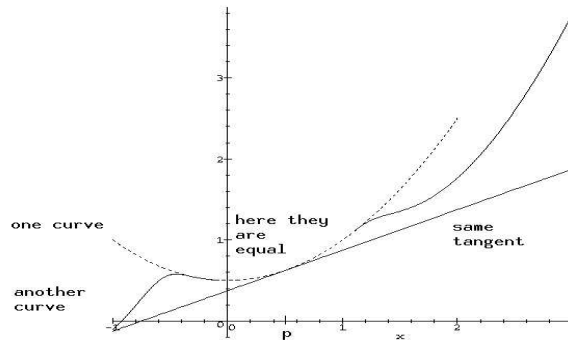

If two curves are equal in a neighborhood of a point, then their tangents are equal.

Definition 4.1.1 Let M and N be differentiable manifolds, and let $p \in M$. On the set

$$X = \{f \mid f: U_f \rightarrow N \text{ is smooth, and } U_f \text{ an open neighborhood of } p\}$$

we define an equivalence relation where f is equivalent to g , written $f \sim g$, if there is an open neighborhood $V_{fg} \subseteq U_f \cap U_g$ of p such that

$$f(q) = g(q), \text{ for all } q \in V_{fg}$$

Such an equivalence class is called a *germ*, and we write

$$\bar{f}: (M, p) \rightarrow (N, f(p))$$

for the germ associated to $f: U_f \rightarrow N$. We also say that f represents \bar{f} .

Note 4.1.2 Germs are quite natural things. Most of the properties we need about germs are obvious if you do not think too hard about it, so it is a good idea to skip the rest of the section which spell out these details before you know what they are good for. Come back later if you need anything precise.

Note 4.1.3 The only thing that is slightly ticklish with the definition of germs is the transitivity of the equivalence relation: assume

$$f: U_f \rightarrow N, \quad g: U_g \rightarrow N, \text{ and } h: U_h \rightarrow N$$

and $f \sim g$ and $g \sim h$. Writing out the definitions, we see that $f = g = h$ on the open set $V_{fg} \cap V_{gh}$, which contains p .

Lemma 4.1.4 *There is a well defined composition of germs which has all the properties you might expect.*

Proof: Let

$$\bar{f}: (M, p) \rightarrow (N, f(p)), \text{ and } \bar{g}: (N, f(p)) \rightarrow (L, g(f(p)))$$

be two germs.

Let them be represented by

$$f: U_f \rightarrow N, \text{ and } g: U_g \rightarrow L$$

Then we define the composite

$$\bar{g} \bar{f}$$

as the germ associated to the composite

$$f^{-1}(U_g) \xrightarrow{f|_{f^{-1}(U_g)}} U_g \xrightarrow{g} L$$

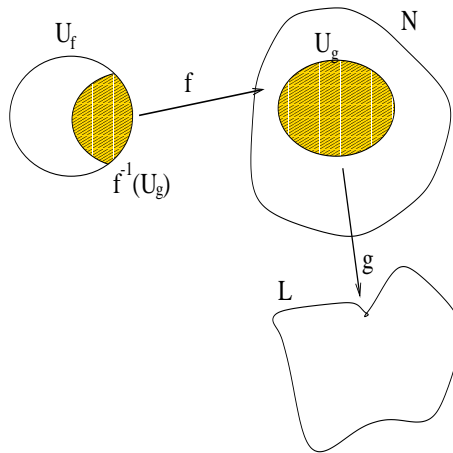

(which is well defined since $f^{-1}(U_g)$ is an open set containing p).

The composite of two germs: just remember to restrict the domain of the representatives.

The “properties you might expect” are associativity and the fact that the germ associated to the identity map acts as an identity. This follows as before by restricting to sufficiently small open sets. ■

We occasionally write \overline{gf} instead of $\bar{g}\bar{f}$ for the composite, even though the pedants will point out that we have to adjust the domains before composing.

Definition 4.1.5 Let M be a smooth manifold and p a point in M . A *function germ* at p is a germ

$$\bar{\phi}: (M, p) \rightarrow (\mathbf{R}, \phi(p))$$

Let

$$\xi(M, p) = \xi(p)$$

be the set of function germs at p .

Example 4.1.6 In $\xi(\mathbf{R}^n, 0)$ there are some very special function germs, namely those associated to the *standard coordinate functions* pr_i sending $p = (p_1, \dots, p_n)$ to $pr_i(p) = p_i$ for $i = 1, \dots, n$.

Note 4.1.7 The set $\xi(M, p) = \xi(p)$ of function germs forms a vector space by pointwise addition and multiplication by real numbers:

$$\begin{array}{ll} \bar{\phi} + \bar{\psi} = \overline{\phi + \psi} & \text{where } (\phi + \psi)(q) = \phi(q) + \psi(q) \text{ for } q \in U_\phi \cap U_\psi \\ k \cdot \bar{\phi} = \overline{k \cdot \phi} & \text{where } (k \cdot \phi)(q) = k \cdot \phi(q) \quad \text{for } q \in U_\phi \\ \bar{0} & \text{where } 0(q) = 0 \quad \text{for } q \in M \end{array}$$

It furthermore has the pointwise multiplication, making it what is called a “commutative \mathbf{R} -algebra”:

$$\begin{array}{ll} \bar{\phi} \cdot \bar{\psi} = \overline{\phi \cdot \psi} & \text{where } (\phi \cdot \psi)(q) = \phi(q) \cdot \psi(q) \text{ for } q \in U_\phi \cap U_\psi \\ \bar{1} & \text{where } 1(q) = 1 \quad \text{for } q \in M \end{array}$$

That these structures obey the usual rules follows by the same rules on \mathbf{R} .

Definition 4.1.8 A germ $\bar{f}: (M, p) \rightarrow (N, f(p))$ defines a function

$$f^*: \xi(f(p)) \rightarrow \xi(p)$$

by sending a function germ $\bar{\phi}: (N, f(p)) \rightarrow (\mathbf{R}, \phi f(p))$ to

$$\overline{\phi f}: (M, p) \rightarrow (\mathbf{R}, \phi f(p))$$

(“precomposition”).

Lemma 4.1.9 If $\bar{f}: (M, p) \rightarrow (N, f(p))$ and $\bar{g}: (N, f(p)) \rightarrow (L, g(f(p)))$ then

$$f^* g^* = (gf)^*: \xi(L, g(f(p))) \rightarrow \xi(M, p)$$

Proof: Both sides send $\bar{\psi}: (L, g(f(p))) \rightarrow (\mathbf{R}, \psi(g(f(p))))$ to the composite

$$\begin{array}{ccc} (M, p) & \xrightarrow{\bar{f}} & (N, f(p)) & \xrightarrow{\bar{g}} & (L, g(f(p))) \\ & & & & \downarrow \bar{\psi} \\ & & & & (\mathbf{R}, \psi(g(f(p)))) \end{array}$$

i.e. $f^*g^*(\bar{\psi}) = f^*(\overline{\psi g}) = \overline{\psi g f} = (gf)^*(\bar{\psi})$. ■

The superscript $*$ may help you remember that it is like this, since it may remind you of transposition in matrices.

Since manifolds are locally Euclidean spaces, it is hardly surprising that on the level of function germs, there is no difference between $(\mathbf{R}^n, 0)$ and (M, p) .

Lemma 4.1.10 *There are isomorphisms $\xi(M, p) \cong \xi(\mathbf{R}^n, 0)$ preserving all algebraic structure.*

Proof: Pick a chart $x: U \rightarrow U'$ with $p \in U$ and $x(p) = 0$ (if $x(p) \neq 0$, just translate the chart). Then

$$x^*: \xi(\mathbf{R}^n, 0) \rightarrow \xi(M, p)$$

is invertible with inverse $(x^{-1})^*$ (note that $\overline{id_U} = \overline{id_M}$ since they agree on an open subset (namely U) containing p). ■

Note 4.1.11 So is this the end of the subject? Could we just as well study \mathbf{R}^n ? **No!** these isomorphisms depend on a **choice of charts**. This is OK if you just look at one point at a time, but as soon as things get a bit messier, this is every bit as bad as choosing particular coordinates in vector spaces.

4.2 The tangent space

Definition 4.2.1 Let M be a differentiable n -dimensional manifold. Let $p \in M$ and let

$$W_p = \{\text{germs } \bar{\gamma} : (\mathbf{R}, 0) \rightarrow (M, p)\}$$

Two germs $\bar{\gamma}, \bar{\nu} \in W_p$ are said to be equivalent, written $\bar{\gamma} \approx \bar{\nu}$, if for all function germs $\bar{\phi} : (M, p) \rightarrow (\mathbf{R}, \phi(p))$

$$(\phi \circ \gamma)'(0) = (\phi \circ \nu)'(0)$$

We define the (geometric) *tangent space* of M at p to be

$$T_p M = W_p / \approx$$

We write $[\bar{\gamma}]$ (or simply $[\gamma]$) for the \approx -equivalence class of $\bar{\gamma}$.

We see that for the definition of the tangent space, it was not necessary to involve the definition of germs, but it is convenient since we are freed from specifying domains of definition all the time.

Note 4.2.2 This definition needs some spelling out. In physical language it says that the tangent space at p is the set of all curves through p with equal derivatives. In particular if $M = \mathbf{R}^n$, then two curves $\gamma_1, \gamma_2: (\mathbf{R}, 0) \rightarrow (\mathbf{R}^n, p)$ define the same tangent vector if and only if all the derivatives are equal:

$$\gamma_1'(0) = \gamma_2'(0)$$

(to say this I really have used the chain rule:

$$(\phi\gamma_1)'(0) = D\phi(p) \cdot \gamma_1'(0),$$

so if $(\phi\gamma_1)'(0) = (\phi\gamma_2)'(0)$ for all function germs ϕ , then we must have $\gamma_1'(0) = \gamma_2'(0)$, and conversely).

In conclusion we have:

Lemma 4.2.3 *Let $M = \mathbf{R}^n$. Then a germ $\bar{\gamma}: (\mathbf{R}, 0) \rightarrow (M, p)$ is \approx -equivalent to the germ represented by*

$$t \mapsto p + \gamma'(0)t$$

That is, all elements in $T_p\mathbf{R}^n$ are represented by linear curves, giving an isomorphism

$$\begin{aligned} T_p\mathbf{R}^n &\cong \mathbf{R}^n \\ [\gamma] &\mapsto \gamma'(0) \end{aligned}$$

Note 4.2.4 The tangent space is a vector space, and like always we fetch the structure locally by means of charts.

Visually it goes like this:

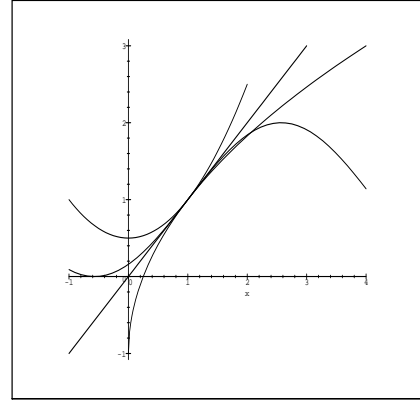

Many curves give rise to the same tangent.

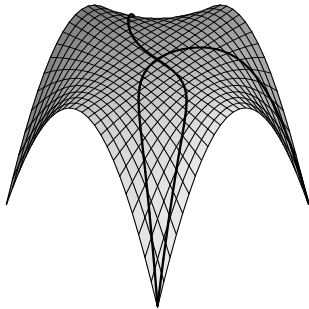

Two curves on M is sent by a chart x to

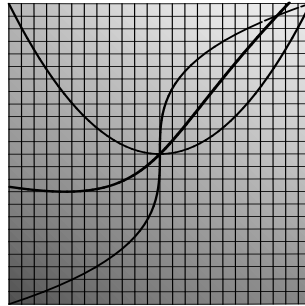

\mathbf{R}^n , where they are added, and the sum

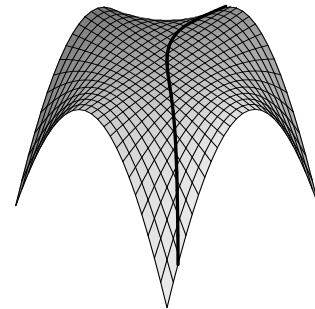

is sent back to M with x^{-1} .

This is all well and fine, but would have been quite worthless if the vector space structure depended on a choice of chart. Of course, it does not. But before we prove that, it is handy to have some more machinery in place to compare the different tangent spaces.

Definition 4.2.5 Let $\bar{f}: (M, p) \rightarrow (N, f(p))$ be a germ. Then we define

$$T_p f: T_p M \rightarrow T_{f(p)} N$$

by

$$T_p f([\gamma]) = [f\gamma]$$

Exercise 4.2.6 This is well defined.

Anybody recognize the next lemma? It is the chain rule!

Lemma 4.2.7 If $\bar{f}: (M, p) \rightarrow (N, f(p))$ and $\bar{g}: (N, f(p)) \rightarrow (L, g(f(p)))$ are germs, then

$$T_{f(p)} g T_p f = T_p (gf)$$

Proof: Let $\bar{\gamma}: (\mathbf{R}, 0) \rightarrow (M, p)$, then

$$T_{f(p)} g (T_p f([\bar{\gamma}])) = T_{f(p)} g ([f\bar{\gamma}]) = [gf\bar{\gamma}] = T_p gf([\bar{\gamma}])$$

■

That's the ultimate proof of the chain rule! The ultimate way to remember it is: the two ways around the triangle

$$\begin{array}{ccc} T_p M & \xrightarrow{T_p f} & T_{f(p)} N \\ & \searrow T_p(gf) & \downarrow T_{f(p)} g \\ & & T_{gf(p)} L \end{array}$$

are the same (“the diagram commutes”).

The “flat chain rule” will be used to show that the tangent spaces are vector spaces and that $T_p f$ is a linear map, but if we were content with working with sets only, this proof of the chain rule would be all we’d ever need.

Note 4.2.8 For the categorists: the tangent space is an assignment from pointed manifolds to vector spaces, and the chain rule states that it is a “functor”.

Lemma 4.2.9 *If $\bar{f}: (\mathbf{R}^m, p) \rightarrow (\mathbf{R}^n, f(p))$, then*

$$T_p f: T_p \mathbf{R}^m \rightarrow T_{f(p)} \mathbf{R}^n$$

is a linear transformation, and

$$\begin{array}{ccc} T_p \mathbf{R}^m & \xrightarrow{T_p f} & T_{f(p)} \mathbf{R}^n \\ \cong \downarrow & & \cong \downarrow \\ \mathbf{R}^m & \xrightarrow{D(f)(p)} & \mathbf{R}^n \end{array}$$

commutes, where the vertical isomorphisms are given by $[\gamma] \mapsto \gamma'(0)$ and $D(f)(p)$ is the Jacobian of f at p (cf. analysis appendix).

Proof: The claim that $T_p f$ is linear follows if we show that the diagram commutes (since the bottom arrow is clearly linear, and the vertical maps are isomorphisms). Starting with a tangent vector $[\gamma] \in T_p \mathbf{R}^m$, we trace it around both ways to \mathbf{R}^n . Going down we get $\gamma'(0)$, and going across the bottom horizontal map we end up with $D(f)(p) \cdot \gamma'(0)$. Going the other way we first send $[\gamma]$ to $T_p f[\gamma] = [f\gamma]$, and then down to $(f\gamma)'(0)$. But the chain rule in the flat case says that these two results are equal:

$$(f\gamma)'(0) = D(f)(\gamma(0)) \cdot \gamma'(0) = D(f)(p) \cdot (\gamma)'(0).$$

■

Lemma 4.2.10 *Let M be a differentiable n -dimensional manifold and let $p \in M$. Let $\bar{x}: (M, p) \rightarrow (\mathbf{R}^n, x(p))$ be a germ associated to a chart around p . Then*

$$T_p x: T_p M \rightarrow T_{x(p)} \mathbf{R}^n$$

is an isomorphism of sets and hence defines a vector space structure on $T_p M$. This structure is independent of \bar{x} , and if

$$\bar{f}: (M, p) \rightarrow (N, f(p))$$

is a germ, then

$$T_p f: T_p M \rightarrow T_{f(p)} N$$

is a linear transformation.

Proof: To be explicit, let $\bar{\gamma}, \bar{\nu}: (\mathbf{R}, 0) \rightarrow (M, p)$, be germs and $a, b \in \mathbf{R}$. The vector space structure given says that

$$a \cdot [\gamma] + b \cdot [\nu] = (T_p x)^{-1}(a \cdot T_p x[\gamma] + b \cdot T_p x[\nu]) = [\bar{x}^{-1}(a \cdot \bar{x}\gamma + b \cdot \bar{x}\bar{\nu})]$$

If $\bar{y}: (M, p) \rightarrow (\mathbf{R}^n, y(p))$ is any other chart, then the diagram

$$\begin{array}{ccc} & T_p M & \\ T_p x \swarrow & & \searrow T_p y \\ T_{x(p)} \mathbf{R}^n & \xrightarrow{T_{x(p)}(yx^{-1})} & T_{y(p)} \mathbf{R}^n \end{array}$$

commutes by the chain rule, and $T_0(yx^{-1})$ is a linear isomorphism, giving that

$$\begin{aligned} (T_p y)^{-1}(a \cdot T_p y[\gamma] + b \cdot T_p y[\nu]) &= (T_p y)^{-1}(a \cdot T_{x(p)}(yx^{-1})T_p x[\gamma] + b \cdot T_{x(p)}(yx^{-1})T_p x[\nu]) \\ &= (T_p y)^{-1}T_{x(p)}(yx^{-1})(a \cdot T_p x[\gamma] + b \cdot T_p x[\nu]) \\ &= (T_p x)^{-1}(a \cdot T_p x[\gamma] + b \cdot T_p x[\nu]) \end{aligned}$$

and so the vector space structure does not depend on the choice of charts.

To see that $T_p f$ is linear, choose a chart germ $\bar{z}: (N, f(p)) \rightarrow (\mathbf{R}^n, zf(p))$. Then the diagram below commutes

$$\begin{array}{ccc} T_p M & \xrightarrow{T_p f} & T_{f(p)} N \\ \cong \downarrow T_p x & & \cong \downarrow T_{f(p)} z \\ T_0 \mathbf{R}^m & \xrightarrow{T_{x(p)}(zfx^{-1})} & T_{zf(p)} \mathbf{R}^n \end{array}$$

and we get that $T_p f$ is linear since $T_{x(p)}(zfx^{-1})$ is. ■

“so I repeat myself, at the risk of being crude”:

Corollary 4.2.11 *Let M be a smooth manifold and $p \in M$. Then $T_p M$ is isomorphic as a vector space to \mathbf{R}^n . Given a chart germ $\bar{x}: (M, p) \rightarrow (\mathbf{R}^m, x(p))$ an isomorphism $T_p M \cong \mathbf{R}^n$ is given by $[\gamma] \mapsto (x\gamma)'(0)$.*

If $\bar{f}: (M, p) \rightarrow (N, f(p))$ is a smooth germ, and $\bar{y}: (N, f(p)) \rightarrow (\mathbf{R}^n, yf(p))$ is another chart germ the diagram below commutes

$$\begin{array}{ccc} T_p M & \xrightarrow{T_p f} & T_{f(p)} N \\ \cong \downarrow & & \cong \downarrow \\ \mathbf{R}^m & \xrightarrow{D(yfx^{-1})(x(p))} & \mathbf{R}^n \end{array}$$

where the vertical isomorphisms are the ones given by x and y , and $D(yfx^{-1})$ is the Jacobian matrix.

4.3 Derivations ¹

Although the definition of the tangent space by means of curves is very intuitive and geometric, the alternative point of view of the tangent space as the space of “derivations” can be very convenient. A derivation is a linear transformation satisfying the Leibnitz rule:

Definition 4.3.1 Let M be a smooth manifold and $p \in M$. A *derivation* (on M at p) is a linear transformation

$$X: \xi(M, p) \rightarrow \mathbf{R}$$

satisfying the *Leibnitz rule*

$$X(\bar{\phi} \cdot \bar{\psi}) = X(\bar{\phi}) \cdot \psi(p) + \phi(p) \cdot X(\bar{\psi})$$

for all function germs $\bar{\phi}, \bar{\psi} \in \xi(M, p)$.

We let $D|_p M$ be the set of all derivations.

Example 4.3.2 Let $M = \mathbf{R}$. Then $\phi \mapsto \phi'(p)$ is a derivation. More generally, if $M = \mathbf{R}^n$ then all the partial derivatives $\phi \mapsto D_j(\phi)(p)$ are derivations.

Note 4.3.3 Note that the set $D|_p M$ of derivations is a vector space: adding two derivations or multiplying one by a real number gives a new derivation. We shall later see that the partial derivatives form a basis for the vector space $D|_p \mathbf{R}^n$.

Definition 4.3.4 Let $\bar{f}: (M, p) \rightarrow (N, f(p))$ be a germ. Then we have a linear transformation

$$D|_p f: D|_p M \rightarrow D|_{f(p)} N$$

given by

$$D|_p f(X) = X f^*$$

(i.e. $D|_p f(X)(\bar{\phi}) = X(\phi f)$).

Lemma 4.3.5 If $\bar{f}: (M, p) \rightarrow (N, f(p))$ and $\bar{g}: (N, f(p)) \rightarrow (L, g(f(p)))$ are germs, then

$$\begin{array}{ccc} D|_p M & \xrightarrow{D|_p f} & D|_{f(p)} N \\ & \searrow D|_p(gf) & \downarrow D|_{f(p)} g \\ & & D|_{gf(p)} L \end{array}$$

commutes.

¹This material is not used in an essential way in the rest of the book. It is included for completeness, and for comparison with other sources.

Proof: Let $X: \xi(M, p) \rightarrow \mathbf{R}$ be a derivation, then

$$D|_{f(p)}g(D|_p f(X)) = D|_{f(p)}g(Xf^*) = (Xf^*)g^* = X(gf)^* = D|_p gf(X).$$

■

Hence as before, everything may be calculated in \mathbf{R}^n instead by means of charts.

Proposition 4.3.6 *The partial derivatives $\{D_i|_0\}_{i=1, \dots, n}$ form a basis for $D|_0\mathbf{R}^n$.*

Proof: Assume

$$X = \sum_{j=1}^n v_j D_j|_0 = 0$$

Then

$$0 = X(\overline{pr}_i) = \sum_{j=1}^n v_j D_j(pr_i)(0) = \begin{cases} 0 & \text{if } i \neq j \\ v_i & \text{if } i = j \end{cases}$$

Hence $v_i = 0$ for all i and we have linear independence.

The proof that the partial derivations span all derivations relies on a lemma from real analysis: Let $\phi: U \rightarrow \mathbf{R}$ be a smooth map where U is an open subset of \mathbf{R}^n containing the origin. Then

$$\phi(p) = \phi(0) + \sum_{i=1}^n p_i \cdot \phi_i(p)$$

(or in function notation: $\phi = \phi(0) + \sum_{i=1}^n pr_i \cdot \phi_i$) where

$$\phi_i(p) = \int_0^1 D_i \phi(t \cdot p) dt$$

which is a combination of the fundamental theorem and the chain rule. Note that $\phi_i(0) = D_i \phi(0)$.

If $X \in D|_0\mathbf{R}^n$ is any derivation, let $v_i = X(\overline{pr}_i)$. If $\bar{\phi}$ is any function germ, we have that

$$\bar{\phi} = \phi(0) + \sum_{i=1}^n \overline{pr}_i \cdot \bar{\phi}_i$$

and so

$$\begin{aligned}
X(\bar{\phi}) &= X(\phi(0)) + \sum_{i=1}^n X(\overline{pr}_i \cdot \bar{\phi}_i) \\
&= 0 + \sum_{i=1}^n (X(\overline{pr}_i) \cdot \phi_i(0) + pr_i(0) \cdot X(\bar{\phi}_i)) \\
&= \sum_{i=1}^n (v_i \cdot \phi_i(0) + 0 \cdot X(\bar{\phi}_i)) \\
&= \sum_{i=1}^n v_i D_i \phi(0)
\end{aligned}$$

■

Thus, given a chart $\bar{x}: (M, p) \rightarrow (\mathbf{R}^n, 0)$ we have a basis for $D|_p M$, and we give this basis the old-fashioned notation to please everybody:

Definition 4.3.7 Consider a chart $\bar{x}: (M, p) \rightarrow (\mathbf{R}^n, x(p))$. Define the derivation in $T_p M$

$$\left. \frac{\partial}{\partial x_i} \right|_p = (D|_p x)^{-1} \left(D_i|_{x(p)} \right)$$

or in more concrete language: if $\bar{\phi}: (M, p) \rightarrow (\mathbf{R}, \phi(p))$ is a function germ, then

$$\left. \frac{\partial}{\partial x_i} \right|_p (\bar{\phi}) = D_i(\phi x^{-1})(x(p))$$

Definition 4.3.8 Let $\bar{f}: (M, p) \rightarrow (N, f(p))$ be a germ, and let $\bar{x}: (M, p) \rightarrow (\mathbf{R}^m, x(p))$ and $\bar{y}: (N, f(p)) \rightarrow (\mathbf{R}^n, yf(p))$ be germs associated to charts. The matrix associated to the linear transformation $D|_p f: D|_p M \rightarrow D|_{f(p)} N$ in the basis given by the partial derivatives of x and y is called the *Jacobi matrix*, and is written $[D|_p f]$. Its ij -entry is

$$[D|_p f]_{ij} = \left. \frac{\partial(y_i f)}{\partial x_j} \right|_p = D_j(y_i f x^{-1})(x(p))$$

(where $y_i = pr_i y$ as usual). This generalizes the notation in the flat case with the identity charts.

Definition 4.3.9 Let M be a smooth manifold and $p \in M$. To every germ $\bar{\gamma}: (\mathbf{R}, 0) \rightarrow (M, p)$ we may associate a derivation $X_\gamma: \xi(M, p) \rightarrow \mathbf{R}$ by setting

$$X_\gamma(\bar{\phi}) = (\phi \gamma)'(0)$$

for every function germ $\bar{\phi}: (M, p) \rightarrow (\mathbf{R}, \phi(p))$.

Note that $X_\gamma(\bar{\phi})$ is the derivative at zero of the composite

$$(\mathbf{R}, 0) \xrightarrow{\bar{\gamma}} (M, p) \xrightarrow{\bar{\phi}} (\mathbf{R}, \phi(p))$$

Exercise 4.3.10 Check that the map $T_p M \rightarrow D|_p M$ sending $[\gamma]$ to X_γ is well defined.

Using the definitions we get the following lemma, which says that the map $T_0 \mathbf{R}^n \rightarrow D|_0 \mathbf{R}^n$ is surjective.

Lemma 4.3.11 *If $v \in \mathbf{R}^n$ and $\bar{\gamma}$ the germ associated to the curve $\gamma(t) = v \cdot t$, then $[\gamma]$ sent to*

$$X_\gamma(\bar{\phi}) = D(\phi)(0) \cdot v = \sum_{i=0}^n v_i D_i(\phi)(0)$$

and so if $v = e_j$ is the j th unit vector, then X_γ is the j th partial derivative at zero.

Lemma 4.3.12 *Let $\bar{f}: (M, p) \rightarrow (N, f(p))$ be a germ. Then*

$$\begin{array}{ccc} T_p M & \xrightarrow{T_p f} & T_{f(p)} N \\ \downarrow & & \downarrow \\ D|_p M & \xrightarrow{D|_p f} & D|_{f(p)} N \end{array}$$

commutes.

Proof: This is clear since $[\gamma]$ is sent to $X_\gamma f^*$ one way, and $X_{f\gamma}$ the other, and if we apply this to a function germ $\bar{\phi}$ we get

$$X_\gamma f^*(\bar{\phi}) = X_\gamma(\bar{\phi} \bar{f}) = (\phi f \gamma)'(0) = X_{f\gamma}(\bar{\phi})$$

■

If you find such arguments hard: remember $\phi f \gamma$ is the **only possible composition of these functions**, and so either side better relate to this!

Proposition 4.3.13 *The assignment $[\gamma] \mapsto X_\gamma$ defines a canonical isomorphism*

$$T_p M \cong D|_p M$$

between the tangent space $T_p M$ and the vector space of derivations $\xi(M, p) \rightarrow \mathbf{R}$.

Proof: The term “canonical” in the proposition refers to the statement in lemma 4.3.12. In fact, we can use this to prove the rest of the proposition.

Choose a germ chart $\bar{x}: (M, p) \rightarrow (\mathbf{R}^n, 0)$. Then lemma 4.3.12 proves that

$$\begin{array}{ccc} T_p M & \xrightarrow[\cong]{T_p \bar{x}} & T_0 \mathbf{R}^n \\ \downarrow & & \downarrow \\ D|_p M & \xrightarrow[\cong]{D|_p \bar{x}} & D|_0 \mathbf{R}^n \end{array}$$

commutes, and the proposition follows if we know that the right hand map is a linear isomorphism.

But we have seen in 4.3.6 that $D|_0 \mathbf{R}^n$ has a basis consisting of partial derivatives, and we noted in 4.3.11 that the map $T_0 \mathbf{R}^n \rightarrow D|_0 \mathbf{R}^n$ hits all the basis elements, and now the proposition follows since the dimension of $T_0 \mathbf{R}^n$ is n (a surjective linear map between vector spaces of the same (finite) dimension is an isomorphism). ■

Note 4.3.14 In the end, this all sums up to say that $T_p M$ and $D|_p M$ are one and the same thing (the categorists would say that “the functors are naturally isomorphic”), and so we will let the notation D slip quietly into oblivion, except if we need to emphasize that we think of the tangent space as a collection of derivations.

Chapter 5

Vector bundles

In this chapter we are going to collect all the tangent spaces of a manifold into one single object, the so-called *tangent bundle*. We defined the tangent space at a point by considering curves passing through the point. In physical terms, the tangent vectors are the velocity vectors of particles passing through our given point. But the particle will have velocities and positions at other times than the one in which it passes through our given point, and the position and velocity may depend continuously upon the time. Such a broader view demands that we are able to keep track of the points on the manifold and their tangent space, and understand how they change from point to point.

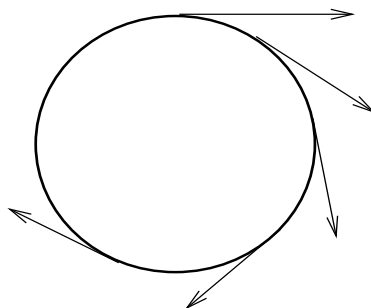

A particle moving on S^1 : some of the velocity vectors are drawn. The collection of all possible combinations of position and velocity ought to assemble into a “tangent bundle”. In this case we see that $S^1 \times \mathbf{R}^1$ would do, but in most instances it won’t be as easy as this.

The tangent bundle is an example of an important class of objects called *vector bundles*.

5.1 Topological vector bundles

Loosely speaking, a vector bundle is a collection of vector spaces parameterized in a locally controllable fashion by some space.

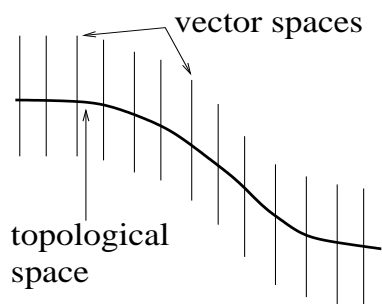

A vector bundle is a topological space to which a vector space is stuck at each point, and everything fitted continuously together.

The easiest example is simply the product $X \times \mathbf{R}^n$, and we will have this as our local model.

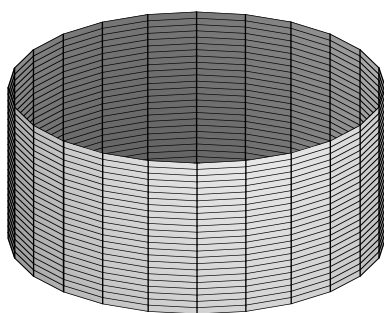

The product of a space and an euclidean space is the local model for vector bundles. The cylinder $S^1 \times \mathbf{R}$ is an example.

Definition 5.1.1 An n -dimensional (real topological) vector bundle is a surjective continuous map

$$\begin{array}{c} E \\ \pi \downarrow \\ X \end{array}$$

such that for every $p \in X$

— the fiber

$$\pi^{-1}(p)$$

has the structure of a real n -dimensional vector space

— there is an open set $U \subseteq X$ containing p

— a homeomorphism

$$h: \pi^{-1}(U) \rightarrow U \times \mathbf{R}^n$$

such that

$$\begin{array}{ccc} \pi^{-1}(U) & \xrightarrow{h} & U \times \mathbf{R}^n \\ & \searrow \pi|_{\pi^{-1}(U)} & \swarrow pr_U \\ & U & \end{array}$$

commutes, and such that for every $q \in U$ the composite

$$h_q: \pi^{-1}(q) \xrightarrow{h|_{\pi^{-1}(q)}} \{q\} \times \mathbf{R}^n \xrightarrow{(q,t) \mapsto t} \mathbf{R}^n$$

is a vector space isomorphism.

Example 5.1.2 The “unbounded Möbius band” given by

$$E = (\mathbf{R} \times [0, 1]) / ((p, 0) \sim (-p, 1))$$

defines a 1-dimensional vector bundle by projecting onto the central circle $E \rightarrow [0, 1] / (0 \sim 1) \cong S^1$.

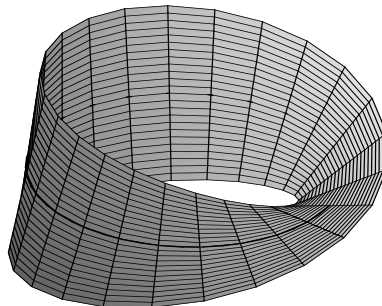

Restricting to an interval on the circle, we clearly see that it is homeomorphic to the product:

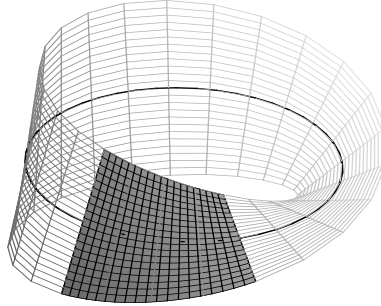

This bundle is often referred to as the *canonical line bundle* over S^1 , and is written $\eta_1 \rightarrow S^1$.

Definition 5.1.3 Given an n -dimensional topological vector bundle $\pi: E \rightarrow X$, we call

$E_q = \pi^{-1}(q)$ the *fiber* over $q \in X$,

E the *total space* and

X the *base space* of the vector bundle.

The existence of the (h, U) s is referred to as the *local trivialization* of the bundle (“the bundle is *locally trivial*”), and the (h, U) s are called *bundle charts*. A *bundle atlas* is a collection \mathcal{B} of bundle charts such that

$$X = \bigcup_{(h,U) \in \mathcal{B}} U$$

(\mathcal{B} “covers” X).

Note 5.1.4 Note the correspondence the definition spells out between h and h_q : for $r \in \pi^{-1}(U)$ we have

$$h(r) = (\pi(r), h_{\pi(r)}(r))$$

It is (bad taste, but) not uncommon to write just E when referring to the vector bundle $E \rightarrow X$.

Example 5.1.5 Given a topological space X , the projection onto the first factor

$$\begin{array}{c} X \times \mathbf{R}^n \\ \text{pr}_X \downarrow \\ X \end{array}$$

is an n -dimensional topological vector bundle.

This example is so totally uninteresting that we call it the *trivial bundle over X* (or more descriptively, the *product bundle*). More generally, any vector bundle $\pi: E \rightarrow X$ with a bundle chart (h, X) is called trivial.

We have to specify the maps connecting the vector bundles. They come in two types, according to whether we allow the base space to change. The more general is:

Definition 5.1.6 A *bundle morphism* from one bundle $\pi: E \rightarrow X$ to another $\pi': E' \rightarrow X'$ is a pair of maps

$$f: X \rightarrow X' \text{ and } \tilde{f}: E \rightarrow E'$$

such that

$$\begin{array}{ccc} E & \xrightarrow{\tilde{f}} & E' \\ \pi \downarrow & & \downarrow \pi' \\ X & \xrightarrow{f} & X' \end{array}$$

commutes, and such that

$$\tilde{f}|_{\pi^{-1}(p)}: \pi^{-1}(p) \rightarrow (\pi')^{-1}(f(p))$$

is a linear map.

Definition 5.1.7 Let $\pi: E \rightarrow X$ be a vector bundle. A *section* to π is a continuous map $\sigma: X \rightarrow E$ such that $\pi\sigma(p) = p$ for all $p \in X$.

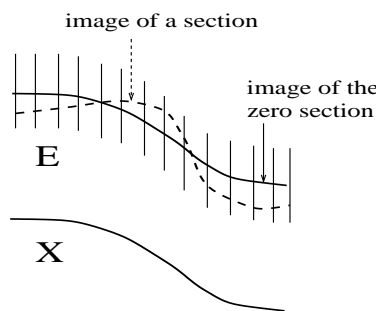

Example 5.1.8 Every vector bundle $\pi: E \rightarrow X$ has a section, namely the *zero section*, which is the map $\sigma_0: X \rightarrow E$ that sends $p \in X$ to zero in the vector space $\pi^{-1}(p)$. As for any section, the map onto its image $X \rightarrow \sigma_0(X)$ is a homeomorphism, and we will occasionally not distinguish between X and $\sigma_0(X)$ (we already did this when we talked informally about the unbounded Möbius band).

Example 5.1.9 The trivial bundle $X \times \mathbf{R}^n \rightarrow X$ has *nonvanishing sections* (i.e. a section whose image does not intersect the zero section), for instance $p \mapsto (p, 1)$ will do. The canonical line bundle $\eta_1 \rightarrow S^1$ (the unbounded Möbius band of example 5.1.2), however, does not. This follows by the intermediate value theorem: a function $f: [0, 1] \rightarrow \mathbf{R}$ with $f(0) = -f(1)$ must have a zero.

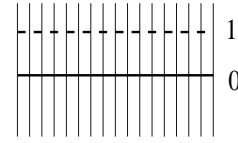

The trivial bundle has nonvanishing sections.

5.2 Transition functions

We will need to endow our bundles with smooth structures, and in order to do this we will use the same trick as we used to define manifolds: transport it down to an issue in Euclidean space. Given two overlapping bundle charts (h, U) and (g, V) , restricting to $\pi^{-1}(U \cap V)$ both define homeomorphisms

$$\pi^{-1}(U \cap V) \rightarrow (U \cap V) \times \mathbf{R}^n$$

which we may compose to give homeomorphisms of $(U \cap V) \times \mathbf{R}^n$ with itself. If the base space is a smooth manifold, we may ask whether this map is smooth.

We need some names to talk about this construction.

Definition 5.2.1 Let $\pi: E \rightarrow X$ be an n -dimensional topological vector bundle, and let \mathcal{B} be a bundle atlas. If $(h, U), (g, V) \in \mathcal{B}$ then

$$gh^{-1}|_{(U \cap V) \times \mathbf{R}^n}: (U \cap V) \times \mathbf{R}^n \rightarrow (U \cap V) \times \mathbf{R}^n$$

are called the *bundle chart transformations*. The restrictions to each fiber

$$g_q h_q^{-1}: \mathbf{R}^n \rightarrow \mathbf{R}^n$$

are linear isomorphisms (i.e. elements in $GL_n(\mathbf{R})$) and the associated function

$$\begin{aligned} U \cap V &\rightarrow GL_n(\mathbf{R}) \\ q &\mapsto g_q h_q^{-1} \end{aligned}$$

are called *transition functions*.

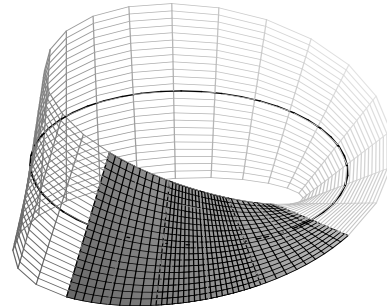

Two bundle charts. Restricting to their intersection, how do the two homeomorphisms to $(U \cap V) \times \mathbf{R}^n$ compare?

Again, visually bundle chart transformations are given by going up and down in

$$\begin{array}{ccc} & \pi^{-1}(U \cap V) & \\ h|_{\pi^{-1}(U \cap V)} \swarrow & & \searrow g|_{\pi^{-1}(U \cap V)} \\ (U \cap V) \times \mathbf{R}^n & & (U \cap V) \times \mathbf{R}^n \end{array}$$

Lemma 5.2.2 *Let W be a topological space, and $f: W \rightarrow M_{m \times n}(\mathbf{R})$ a continuous function. Then the associated function*

$$\begin{aligned} f_*: W \times \mathbf{R}^n &\rightarrow \mathbf{R}^m \\ (w, v) &\mapsto f(w) \cdot v \end{aligned}$$

is continuous iff f is. If W is a smooth manifold, then f_ is smooth iff f is.*

Proof: Note that f_* is the composite

$$W \times \mathbf{R}^n \xrightarrow{f \times id} M_{m \times n}(\mathbf{R}) \times \mathbf{R}^n \xrightarrow{e} \mathbf{R}^m$$

where $e(A, v) = A \cdot v$. Since e is smooth, it follows that if f is continuous or smooth, then so is f_* .

Conversely, considered as a matrix, we have that

$$[f(w)] = [f_*(w, e_1), \dots, f_*(w, e_n)]$$

If f_* is continuous (or smooth), then we see that each column of $[f(w)]$ depends continuously (or smoothly) on w , and so f is continuous (or smooth). ■

So, requiring the bundle chart transformations to be smooth is the same as to require the transition functions to be smooth, and we will often take the opportunity to confuse this.

Exercise 5.2.3 Show that any vector bundle $E \rightarrow [0, 1]$ is trivial.

Exercise 5.2.4 Show that any 1-dimensional vector bundle (also called *line bundle*) $E \rightarrow S^1$ is either trivial, or $E \cong \eta_1$. Show the analogous statement for n -dimensional vector bundles.

5.3 Smooth vector bundles

Definition 5.3.1 Let M be a smooth manifold, and let $\pi: E \rightarrow M$ be a vector bundle. A bundle atlas is said to be *smooth* if all the transition functions are smooth.

Note 5.3.2 Spelling the differentiability out in full detail we get the following: Let (M, \mathcal{A}) be a smooth n -dimensional manifold, $\pi: E \rightarrow M$ a k -dimensional vector bundle, and \mathcal{B} a bundle atlas. Then \mathcal{B} is smooth if for all bundle charts $(h_1, U_1), (h_2, U_2) \in \mathcal{B}$ and all charts $(x_1, V_1), (x_2, V_2) \in \mathcal{A}$, the composites going up over and across

$$\begin{array}{ccc}
 & \pi^{-1}(U) & \\
 h_1|_{\pi^{-1}(U)} \swarrow & & \searrow h_2|_{\pi^{-1}(U)} \\
 U \times \mathbf{R}^k & & U \times \mathbf{R}^k \\
 x_1|_{U \times id} \downarrow & & \downarrow x_2|_{U \times id} \\
 x_1(U) \times \mathbf{R}^k & & x_2(U) \times \mathbf{R}^k
 \end{array}$$

is a smooth function in \mathbf{R}^{n+k} , where $U = U_1 \cap U_2 \cap V_1 \cap V_2$.

Example 5.3.3 If M is a smooth manifold, then the trivial bundle is a smooth vector bundle in an obvious manner.

Example 5.3.4 The canonical line bundle (unbounded Möbius strip) $\eta_1 \rightarrow S^1$ is a smooth vector bundle. As a matter of fact, the trivial bundle and the canonical line bundle are the only one-dimensional smooth vector bundles over the circle (see example 5.2.4 for the topological case. The smooth case needs partitions of unity, which we will cover at a later stage, see exercise 7.2.6).

Note 5.3.5 Just as for atlases of manifolds, we have a notion of a *maximal (smooth) bundle atlas*, and to each smooth atlas we may associate a unique maximal one in exactly the same way as before.

Definition 5.3.6 A *smooth vector bundle* is a vector bundle equipped with a maximal smooth bundle atlas.

We will often suppress the bundle atlas from the notation, so a smooth vector bundle $(\pi: E \rightarrow M, \mathcal{B})$ will occasionally be written simply $\pi: E \rightarrow M$ (or even worse E), if the maximal atlas \mathcal{B} is clear from the context.

Definition 5.3.7 A smooth vector bundle $(\pi: E \rightarrow M, \mathcal{B})$ is *trivial* if its (maximal smooth) atlas \mathcal{B} contains a chart (h, M) with domain all of M .

Lemma 5.3.8 *The total space E of a smooth vector bundle $(\pi: E \rightarrow M, \mathcal{B})$ has a natural smooth structure, and π is a smooth map.*

Proof: Let M be n -dimensional with atlas \mathcal{A} , and let π be k -dimensional. Then the diagram in 5.3.2 shows that E is a smooth $(n+k)$ -dimensional manifold. That π is smooth is the

same as claiming that all the up over and across composites

$$\begin{array}{ccc}
 & \pi^{-1}(U) & \\
 h|_{\pi^{-1}(U)} \swarrow & & \searrow \pi|_{\pi^{-1}(U)} \\
 U \times \mathbf{R}^k & & U \\
 x_1|_U \times id \downarrow & & \downarrow x_2|_U \\
 x_1(U) \times \mathbf{R}^k & & x_2(U)
 \end{array}$$

are smooth where $(x_1, V_1), (x_2, V_2) \in \mathcal{A}$, $(h, W) \in \mathcal{B}$ and $U = V_1 \cap V_2 \cap W$. But

$$\begin{array}{ccc}
 & \pi^{-1}(U) & \\
 h|_{\pi^{-1}(U)} \swarrow & & \searrow \pi|_{\pi^{-1}(U)} \\
 U \times \mathbf{R}^k & \xrightarrow{pr_U} & U
 \end{array}$$

commutes, so the composite is simply

$$x_1(U) \times \mathbf{R}^k \xrightarrow{pr_{x_1(U)}} x_1(U) \xleftarrow{x_1|_U} U \xrightarrow{x_2|_U} x_2(U)$$

which is smooth since \mathcal{A} is smooth. ■

Note 5.3.9 As expected, the proof shows that $\pi: E \rightarrow M$ locally looks like the projection

$$\mathbf{R}^n \times \mathbf{R}^k \rightarrow \mathbf{R}^n$$

(followed by a diffeomorphism).

Definition 5.3.10 A *smooth bundle morphism* is a bundle morphism

$$\begin{array}{ccc}
 E & \xrightarrow{\tilde{f}} & E' \\
 \pi \downarrow & & \downarrow \pi' \\
 M & \xrightarrow{f} & M'
 \end{array}$$

from a smooth vector bundle to another such that \tilde{f} and f are smooth.

Definition 5.3.11 An *isomorphism* of two smooth vector bundles

$$\pi: E \rightarrow M \text{ and } \pi': E' \rightarrow M$$

over the same base space M is an invertible smooth bundle morphism over the identity on M :

$$\begin{array}{ccc}
 E & \xrightarrow{\tilde{f}} & E' \\
 \pi \downarrow & & \downarrow \pi' \\
 M & \xlongequal{\quad} & M
 \end{array}$$

Checking whether a bundle morphism is an isomorphism reduces to checking that it is a bijection:

Lemma 5.3.12 *Let*

$$\begin{array}{ccc} E & \xrightarrow{\tilde{f}} & E' \\ \pi \downarrow & & \downarrow \pi' \\ M & \xlongequal{\quad} & M \end{array}$$

be a smooth (or continuous) bundle morphism. If \tilde{f} is bijective, then it is a smooth (or continuous) isomorphism.

Proof: That \tilde{f} is bijective means that it is a bijective linear map on every fiber, or in other words: a vector space isomorphism on every fiber. Choose charts (h, U) in E and (h', U) in E' around $p \in U \subseteq M$ (may choose the U 's to be the same). Then

$$h' \tilde{f} h^{-1} : U \times \mathbf{R}^n \rightarrow U \times \mathbf{R}^n$$

is of the form $(u, v) \mapsto (u, \alpha_u v)$ where $\alpha_u \in \text{GL}_n(\mathbf{R})$ depends smoothly (or continuously) on $u \in U$. But by Cramer's rule $(\alpha_u)^{-1}$ depends smoothly on α_u , and so the inverse

$$\left(h' \tilde{f} h^{-1} \right)^{-1} : U \times \mathbf{R}^n \rightarrow U \times \mathbf{R}^n, \quad (u, v) \mapsto (u, (\alpha_u)^{-1} v)$$

is smooth (or continuous) proving that the inverse of \tilde{f} is smooth (or continuous). ■

5.4 Pre-vector bundles

A smooth or topological vector bundle is a very structured object, and much of its structure is intertwined very closely. There is a sneaky way out of having to check topological properties all the time. As a matter of fact, the topology is determined by some of the other structure as soon as the claim that it is a vector bundle is made: specifying the topology on the total space is redundant!.

Definition 5.4.1 A *pre-vector bundle* is

a set E (*total space*)

a topological space X (*base space*)

a surjective function $\pi: E \rightarrow X$

a vector space structure on the fiber $\pi^{-1}(q)$ for each $q \in X$

a *pre-bundle atlas* \mathcal{B} , i.e. a set of bijective functions

$$h: \pi^{-1}(U) \rightarrow U \times \mathbf{R}^n$$

with $U \subseteq X$ open, such that

\mathcal{B} covers X (i.e. $X = \bigcup_{(h,U) \in \mathcal{B}} U$)

for every $q \in X$

$$h_q: \pi^{-1}(q) \rightarrow \mathbf{R}^n$$

is a linear isomorphism, and

the transition functions are continuous.

Definition 5.4.2 A *smooth pre-vector bundle* is a pre-vector bundle where the base space is a smooth manifold and the transition functions are smooth.

Lemma 5.4.3 *Given a pre-vector bundle, there is a unique vector bundle with underlying pre-vector bundle the given one. The same statement holds for the smooth case.*

Proof: Let $(\pi: E \rightarrow X, \mathcal{B})$ be a pre-vector bundle. We must equip E with a topology such that π is continuous and the bijections in the bundle atlas are homeomorphisms. The smooth case follows then immediately from the continuous case.

We must have that if $(h, U) \in \mathcal{B}$, then $\pi^{-1}(U)$ is an open set in E (for π to be continuous). The family of open sets $\{\pi^{-1}(U)\}_{U \subseteq X \text{ open}}$ covers E , so we only need to know what the open subsets of $\pi^{-1}(U)$ are, but this follows by the requirement that the bijection h should be a homeomorphism. That is $V \subseteq \pi^{-1}(U)$ is open if $V = h^{-1}(V')$ for some open $V' \subseteq U \times \mathbf{R}^k$. Ultimately, we get that

$$\left\{ h^{-1}(V_1 \times V_2) \mid (h, U) \in \mathcal{B}, \begin{array}{l} V_1 \text{ open in } U, \\ V_2 \text{ open in } \mathbf{R}^k \end{array} \right\}$$

is a basis for the topology on E . ■

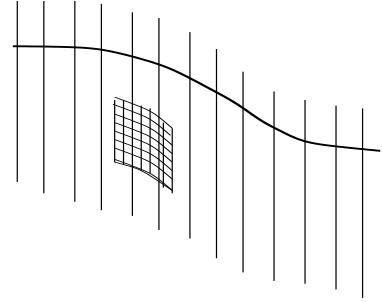

A typical open set in $\pi^{-1}(U)$ gotten as h^{-1} of the product of an open set in U and an open set in \mathbf{R}^k

Exercise 5.4.4 Let

$$\eta_n = \{([p], \lambda p) \in \mathbf{RP}^n \times \mathbf{R}^{n+1} \mid p \in S^n, \lambda \in \mathbf{R}\}$$

Show that the projection

$$\begin{aligned} \eta_n &\rightarrow \mathbf{RP}^n \\ ([p], \lambda p) &\mapsto [p] \end{aligned}$$

defines a non-trivial smooth vector bundle.

Exercise 5.4.5 Let $p \in \mathbf{RP}^n$ and $X = \mathbf{RP}^n \setminus \{p\}$. Show that X is diffeomorphic to the total space η_{n-1} of exercise 5.4.4.

5.5 The tangent bundle

We define the tangent bundle as follows:

Definition 5.5.1 Let (M, \mathcal{A}) be a smooth n -dimensional manifold. The tangent bundle of M is defined by the following smooth pre-vector bundle

$$TM = \coprod_{p \in M} T_p M \text{ (total space)}$$

M (base space)

$\pi : TM \rightarrow M$ sends $T_p M$ to p

the pre-vector bundle atlas

$$\mathcal{B}_{\mathcal{A}} = \{(h_x, U) \mid (x, U) \in \mathcal{A}\}$$

where h_x is given by

$$\begin{aligned} h_x : \pi^{-1}(U) &\rightarrow U \times \mathbf{R}^n \\ [\gamma] &\mapsto (\gamma(0), (x\gamma)'(0)) \end{aligned}$$

Note 5.5.2 Since the tangent bundle is a smooth vector bundle, the total space TM is a smooth $2n$ -dimensional manifold. To be explicit, its atlas is gotten from the smooth atlas on M as follows.

If (x, U) is a chart on M ,

$$\begin{aligned} \pi^{-1}(U) &\xrightarrow{h_x} U \times \mathbf{R}^n \xrightarrow{x \times id} x(U) \times \mathbf{R}^n \\ &[\gamma] \mapsto (x\gamma(0), (x\gamma)'(0)) \end{aligned}$$

is a homeomorphism to an open subset of $\mathbf{R}^n \times \mathbf{R}^n$. It is convenient to have an explicit formula for the inverse. Let $(p, v) \in x(U) \times \mathbf{R}^n$. Define the germ

$$\gamma(p, v) : (\mathbf{R}, 0) \rightarrow (\mathbf{R}^n, p)$$

by sending t (in a sufficiently small open interval containing zero) to $p + tv$. Then the inverse is given by sending (p, v) to

$$[x^{-1}\gamma(p, v)] \in T_{x^{-1}(p)}M$$

Lemma 5.5.3 Let $f : (M, \mathcal{A}_M) \rightarrow (N, \mathcal{A}_N)$ be a smooth map. Then

$$[\gamma] \mapsto Tf[\gamma] = [f\gamma]$$

defines a smooth bundle morphism

$$\begin{array}{ccc} TM & \xrightarrow{Tf} & TN \\ \pi_M \downarrow & & \pi_N \downarrow \\ M & \xrightarrow{f} & N \end{array}$$

Proof: Since $Tf|_{\pi^{-1}(p)} = T_p f$ we have linearity on the fibers, and we are left with showing that Tf is a smooth map. Let $(x, U) \in \mathcal{A}_M$ and $(y, V) \in \mathcal{A}_N$. We have to show that up, across and down in

$$\begin{array}{ccc} \pi_M^{-1}(W) & \xrightarrow{Tf|} & \pi_N^{-1}(V) \\ h_x|_W \downarrow & & h_y \downarrow \\ W \times \mathbf{R}^m & & V \times \mathbf{R}^n \\ x|_W \times id \downarrow & & y \times id \downarrow \\ x(W) \times \mathbf{R}^m & & y(V) \times \mathbf{R}^n \end{array}$$

is smooth, where $W = U \cap f^{-1}(V)$ and $Tf|$ is Tf restricted to $\pi_M^{-1}(W)$. This composite sends $(p, v) \in x(W) \times \mathbf{R}^m$ to $[x^{-1}\gamma(p, v)] \in \pi_M^{-1}(W)$ to $[fx^{-1}\gamma(p, v)] \in \pi_N^{-1}(V)$ and finally to $(yfx^{-1}\gamma(p, v)(0), (yfx^{-1}\gamma(p, v))'(0)) \in y(V) \times \mathbf{R}^n$ which is equal to

$$(yfx^{-1}(p), D(yfx^{-1})(p) \cdot v)$$

by the chain rule. Since yfx^{-1} is a smooth function, this is a smooth function too. ■

Lemma 5.5.4 *If $f: M \rightarrow N$ and $g: N \rightarrow L$ are smooth, then*

$$TgTf = T(gf)$$

Proof: It is the chain rule (made pleasant since the notation does not have to tell you where you are at all the time). ■

Note 5.5.5 The tangent space of \mathbf{R}^n is trivial, since the identity chart induces a bundle chart

$$\begin{aligned} h_{id}: T\mathbf{R}^n &\rightarrow \mathbf{R}^n \times \mathbf{R}^n \\ [\gamma] &\mapsto (\gamma(0), \gamma'(0)) \end{aligned}$$

Definition 5.5.6 A manifold is often said to be *parallelizable* if its tangent bundle is trivial.

Example 5.5.7 The circle is parallelizable. This is so since the map

$$\begin{aligned} S^1 \times T_1 S^1 &\rightarrow TS^1 \\ (e^{i\theta}, [\gamma]) &\mapsto [e^{i\theta} \cdot \gamma] \end{aligned}$$

is a diffeomorphism (here $(e^{i\theta} \cdot \gamma)(t) = e^{i\theta} \cdot \gamma(t)$).

Exercise 5.5.8 The tree-sphere S^3 is parallelizable

Exercise 5.5.9 All Lie groups are parallelizable. (A Lie group is a manifold with a smooth associative multiplication, with a unit and all inverses: skip this exercise if this sounds too alien to you).

Example 5.5.10 Let

$$E = \{(p, v) \in \mathbf{R}^{n+1} \times \mathbf{R}^{n+1} \mid |p| = 1, p \cdot v = 0\}$$

Then

$$\begin{aligned} TS^n &\rightarrow E \\ [\gamma] &\mapsto (\gamma(0), \gamma'(0)) \end{aligned}$$

is a homeomorphism. The inverse sends $(p, v) \in E$ to the equivalence class of the germ associated to

$$t \mapsto \frac{p + tv}{|p + tv|}$$

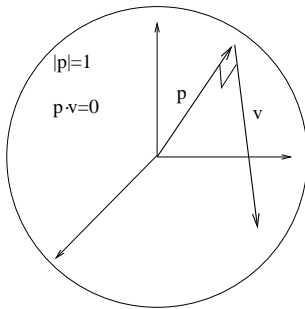

A point in the tangent space of S^2 may be represented by a unit vector p together with an arbitrary vector v perpendicular to p .

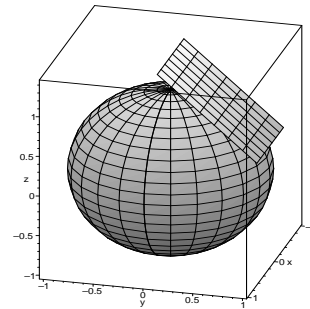

We can't draw all the tangent planes simultaneously to illustrate the tangent space of S^2 . The description we give is in \mathbf{R}^6 .

More generally we have the following fact:

Lemma 5.5.11 Let $f: M \rightarrow N$ be an imbedding. Then $Tf: TM \rightarrow TN$ is an imbedding.

Proof: We may assume that f is the inclusion of a submanifold (the diffeomorphism part is taken care of by the chain rule which implies that Tf is a diffeomorphism if f is). Let $y: V \rightarrow V'$ be a chart on N such that $y(V \cap M) = V' \cap (\mathbf{R}^m \times \{0\})$. Since curves in $\mathbf{R}^m \times \{0\}$ have derivatives in $\mathbf{R}^m \times \{0\}$ we see that

$$\begin{aligned} (y \times id)h_y(Tf(\pi_M^{-1}(W \cap M))) &= (V' \cap (\mathbf{R}^m \times \{0\})) \times \mathbf{R}^m \times \{0\} \\ &\subseteq \mathbf{R}^m \times \mathbf{R}^k \times \mathbf{R}^m \times \mathbf{R}^k \end{aligned}$$

and by permuting the coordinates we have that Tf is the inclusion of a submanifold. ■

Corollary 5.5.12 *If $M \subseteq \mathbf{R}^N$ is the inclusion of a smooth submanifold of an Euclidean space, then*

$$TM \cong \left\{ (p, v) \in \mathbf{M} \times \mathbf{R}^N \mid \begin{array}{l} v = \gamma'(0) \\ \text{for some germ } \bar{\gamma}: (\mathbf{R}, 0) \rightarrow (M, p) \end{array} \right\}$$

(the derivation of γ happens in \mathbf{R}^N)

Exercise 5.5.13 There is an even groovier description of TS^n : prove that

$$E = \left\{ (z_0, \dots, z_n) \in \mathbf{C}^{n+1} \mid \sum_{i=0}^n z_i^2 = 1 \right\}$$

is the total space in a bundle isomorphic to TS^n .

Definition 5.5.14 Let M be a smooth manifold. A *vector field* on M is a section in the tangent bundle.

Example 5.5.15 The circle has nonvanishing vector fields. Let $[\gamma] \neq 0 \in T_1S^1$, then

$$S^1 \rightarrow TS^1, \quad e^{i\theta} \mapsto [e^{i\theta} \cdot \gamma]$$

is a vector field (since $e^{i\theta} \cdot \gamma(0) = e^{i\theta} \cdot 1$) and does not intersect the zero section since (viewed as a vector in \mathbf{C})

$$|(e^{i\theta} \cdot \gamma)'(0)| = |e^{i\theta} \cdot \gamma'(0)| = |\gamma'(0)| \neq 0$$

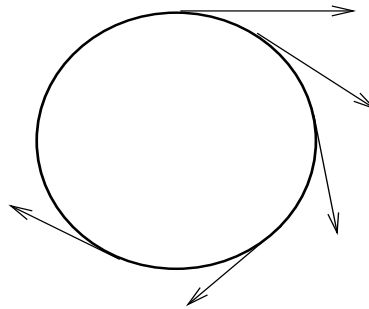

The vector field spins around the circle with constant speed.

This is the same construction we used to show that S^1 was parallelizable. This is a general argument: an n dimensional manifold with n linearly independent vector fields has a trivial tangent bundle, and conversely.

Exercise 5.5.16 Construct three vector fields on S^3 that are linearly independent in all tangent spaces.

Exercise 5.5.17 Prove that $T(M \times N) \cong TM \times TN$.

Example 5.5.18 We have just seen that S^1 and S^3 (if you did the exercise) both have nonvanishing vector fields. It is a hard fact that S^2 does not: “you can’t comb the hair on a sphere”.

This has the practical consequence that when you want to confine the plasma in a fusion reactor by means of magnetic fields, you can’t choose to let the plasma be in the interior of a sphere (or anything homeomorphic to it). At each point on the surface, the component of the magnetic field parallel to the surface must be nonzero, or the plasma will leak out (if you remember your physics, there once was a formula saying something like $F = qv \times B$ where q is the charge of the particle, v its velocity and B the magnetic field: hence any particle moving nonparallel to the magnetic field will be deflected).

This problem is solved by letting the plasma stay inside a torus $S^1 \times S^1$ which does have nonvanishing vector fields (since S^1 has and $T(S^1 \times S^1) \cong TS^1 \times TS^1$ by the above exercise).

Although there are no nonvanishing vector fields on S^2 , there are certainly interesting ones that have a few zeros. For instance “rotation around an axis” will give you a vector field with only two zeros. The “magnetic dipole” defines a vector field on S^2 with just one zero.

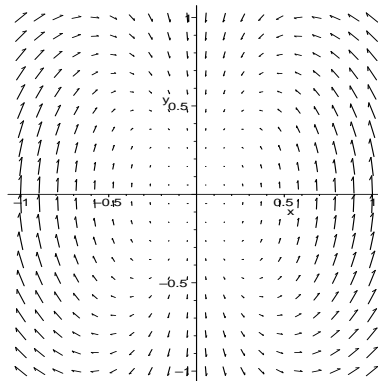

A magnetic dipole on S^2 , seen by stereographic projection in a neighbourhood of the only zero.

Chapter 6

Submanifolds

In this chapter we will give several important results regarding submanifolds. This will serve a twofold purpose. First of all we will acquire a powerful tool for constructing new manifolds as inverse images of smooth functions. Secondly we will clear up the somewhat mysterious definition of submanifolds. These results are consequences of the *rank theorem*, which says roughly that smooth maps are – locally around “most” points – like linear projections or inclusions of Euclidean spaces.

6.1 The rank

Definition 6.1.1 Let $\bar{f}: (M, p) \rightarrow (N, f(p))$ be a smooth germ. The *rank* $rk_p f$ of f at p is the rank of the linear map $T_p f$. We say that a germ \bar{f} has *constant rank* r if it has a representative $f: U_f \rightarrow N$ whose $rk T_q f = r$ for all $q \in U_f$. We say that a germ \bar{f} has $rk \geq r$ if it has a representative $f: U_f \rightarrow N$ whose $rk T_q f \geq r$ for all $q \in U_f$.

Lemma 6.1.2 Let $\bar{f}: (M, p) \rightarrow (N, f(p))$ be a smooth germ. If $rk_p f = r$ then there exists a neighborhood of p such that $rk_q f \geq r$ for all $q \in U$.

Proof: Strategy: choose charts x and y , and use that the rank of the Jacobi matrix

$$[D_j(p r_i y f x^{-1})(x(q))]$$

does not decrease locally. This is true since the Jacobi matrix at $x(p)$ must contain an $r \times r$ submatrix which has determinant different from zero. But since the determinant function is continuous, there must be a neighborhood around $x(p)$ for which the determinant of the $r \times r$ submatrix stays nonzero, and hence the rank of the Jacobi matrix is at least r . ■

Note 6.1.3 As a matter of fact, we have shown that the subspace $M_n^r(\mathbf{R}) \subseteq M_n(\mathbf{R})$ of rank r $n \times n$ matrices is a submanifold of codimension $(n - r)^2$. Perturbing a rank r matrix may kick you out of this manifold and into one of higher rank.

Example 6.1.4 The map $f: \mathbf{R} \rightarrow \mathbf{R}$ given by $f(p) = p^2$ has $Df(p) = 2p$, and so

$$rk_p f = \begin{cases} 0 & p = 0 \\ 1 & p \neq 0 \end{cases}$$

Example 6.1.5 Consider the determinant $det: M_2(\mathbf{R}) \rightarrow \mathbf{R}$ with

$$det = a_{11}a_{22} - a_{12}a_{21}, \text{ for } A = \begin{bmatrix} a_{11} & a_{12} \\ a_{21} & a_{22} \end{bmatrix}$$

Using the chart $x: M_2(\mathbf{R}) \rightarrow \mathbf{R}^4$ with

$$x(A) = \begin{bmatrix} a_{11} \\ a_{12} \\ a_{21} \\ a_{22} \end{bmatrix}$$

(and the identity chart on \mathbf{R}) we have that

$$[D(det x^{-1})(x(A))] = [a_{22}, -a_{21}, -a_{12}, a_{11}]$$

(check this!) Thus we see that

$$rk_A det = \begin{cases} 0 & A = 0 \\ 1 & A \neq 0 \end{cases}$$

By a bit of work we may prove this result also for $det: M_n(\mathbf{R}) \rightarrow \mathbf{R}$ for all n .

Definition 6.1.6 Let $f: M \rightarrow N$ be a smooth map where N is n -dimensional. A point $p \in M$ is *regular* if $T_p f$ is surjective (i.e. if $rk_p f = n$). A point $q \in N$ is a *regular value* if all $p \in f^{-1}(q)$ are regular points. Synonyms for “non-regular” are *critical* or *singular*.

Note that a point q which is not in the image of f is a regular value since $f^{-1}(q) = \emptyset$.

Note 6.1.7 We shall later see that these names are well chosen: the regular values are the most common ones (Sard’s theorem states this precisely, see theorem 6.6.1), whereas the critical values are critical in the sense that they exhibit bad behavior. The inverse image $f^{-1}(q) \subseteq M$ of a regular value q will turn out to be a submanifold, whereas inverse images of critical points usually are not.

Example 6.1.8 The names correspond to the normal usage in multi-variable calculus.

For instance, if you consider the function

$$f: \mathbf{R}^2 \rightarrow \mathbf{R}$$

whose graph is depicted to the right, the critical points – i.e. the points $p \in \mathbf{R}^2$ such that

$$D_1f(p) = D_2f(p) = 0$$

– will correspond to the two local maxima and the saddle point. We note that the contour lines at all other values are nice 1-dimensional submanifolds of \mathbf{R}^2 (circles, or disjoint unions of circles).

In the picture to the right, we have considered a standing torus, and looked at its height function. The contour lines are then inverse images of various height values. If we had written out the formulas we could have calculated the rank of the height function at every point of the torus, and we would have found four critical points: one on the top, one on “the top of the hole”, one on “the bottom of the hole” (the point on the figure where you see two contour lines cross) and one on the bottom. The contours at these heights look like points or figure eights, whereas contour lines at other values are one or two circles.

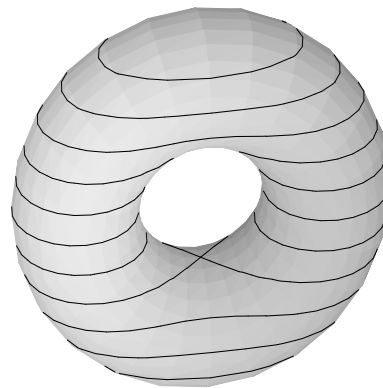
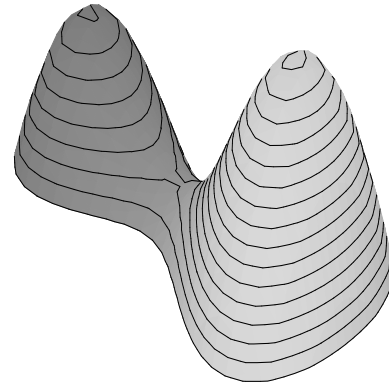

The robot example REF, was also an example of this type of phenomenon.

6.2 The inverse function theorem

Theorem 6.2.1 (The inverse function theorem) *A smooth germ*

$$\bar{f}: (M, p) \rightarrow (N, f(p))$$

is invertible if and only if

$$T_p f: T_p M \rightarrow T_{f(p)} N$$

is invertible, in which case $T_{f(p)}(f^{-1}) = (T_p f)^{-1}$.

Proof: Choose charts (x, U) and (y, V) with $p \in U$ and $f(p) \in V$. In the bases

$$\left. \frac{\partial}{\partial x_i} \right|_p, \text{ and } \left. \frac{\partial}{\partial y_j} \right|_{f(p)}$$

$T_p f$ is given by the Jacobi matrix

$$[D(yf x^{-1})(x(p))] = [D_j(p r_i y f x^{-1}(x(p)))]$$

so $T_p f$ is invertible iff $[D(yf x^{-1})(x(p))]$ is invertible. By the inverse function theorem 11.2.1 in the flat case, this is the case iff $yf x^{-1}$ is invertible in a neighborhood of $x(p)$. As x and y are diffeomorphisms, this is the same as saying that f is invertible in a neighborhood around p . ■

Corollary 6.2.2 *Let $f: M \rightarrow N$ be a smooth map between smooth n -manifolds. Then f is a diffeomorphism iff it is bijective and $T_p f$ is of rank n for all $p \in M$.*

Proof: Since f is bijective it has an inverse function. A function has at most one inverse function (!) so the smooth inverse functions existing locally by the inverse function theorem, must be equal to the globally defined inverse function which hence is smooth. ■

Exercise 6.2.3 Let G be a Lie group (a manifold with a smooth associative multiplication, with a unit and all inverses).

Show that

$$\begin{aligned} G &\rightarrow G \\ g &\mapsto g^{-1} \end{aligned}$$

is smooth (some authors have this as a part of the definition, which is totally redundant).

6.3 The rank theorem

The rank theorem says that if the rank of a smooth map $f: M \rightarrow N$ is constant in a neighborhood of a point, then there are charts so that f looks like a composite $\mathbf{R}^m \rightarrow \mathbf{R}^r \subseteq \mathbf{R}^n$, where the first map is the projection onto the first $r < m$ coordinate directions, and the last one is the inclusion of the first $r < n$ coordinates. So for instance, a map of rank 1 between 2-manifolds looks locally like

$$\mathbf{R}^2 \rightarrow \mathbf{R}^2, \quad (q_1, q_2) \mapsto (q_1, 0)$$

Lemma 6.3.1 (*The rank theorem*) Let $\bar{f}: (M, p) \rightarrow (N, f(p))$ be a germ of rank $\geq r$. Then there exist chart germs

$$\bar{x}: (M, p) \rightarrow (\mathbf{R}^m, x(p)) \text{ and } \bar{y}: (N, f(p)) \rightarrow (\mathbf{R}^n, yf(p))$$

such that

$$pr_j y f x^{-1}(q) = q_j \text{ for } j = 1, \dots, r$$

for all $q = (q_1, \dots, q_m)$ sufficiently close to $x(p)$. Furthermore, given **any** chart \bar{y} we can achieve this by a choice of \bar{x} , and permuting the coordinates in \bar{y} .

If \bar{f} has constant rank r , then there exist chart germs

$$\bar{x}: (M, p) \rightarrow (\mathbf{R}^m, x(p)) \text{ and } \bar{y}: (N, f(p)) \rightarrow (\mathbf{R}^n, yf(p))$$

such that

$$y f x^{-1}(q) = (q_1, \dots, q_r, 0, \dots, 0)$$

for all $q = (q_1, \dots, q_m)$ sufficiently close to $x(p)$.

Proof: If we start with arbitrary charts, we will fix them up so that we have the theorem. Hence we may just as well assume that $(M, p) = (\mathbf{R}^m, 0)$ and $(N, f(p)) = (\mathbf{R}^n, 0)$, that $f: (\mathbf{R}^m, 0) \rightarrow (\mathbf{R}^n, 0)$ is a representative of the germ (if the representative you first chose was not defined everywhere, restrict to a small ball close to zero, and use a chart to define it on all of \mathbf{R}^m), and that the Jacobian $Df(0)$ has the form

$$Df(0) = \begin{bmatrix} A & B \\ C & D \end{bmatrix}$$

where A is an invertible $r \times r$ matrix (here we have used that we could permute the coordinates).

Let $f_i = pr_i f$, and define $x: (\mathbf{R}^m, 0) \rightarrow (\mathbf{R}^m, 0)$ by

$$x(t) = (f_1(t), \dots, f_r(t), t_{r+1}, \dots, t_m)$$

(where $t_j = pr_j(t)$). Then

$$Dx(0) = \begin{bmatrix} A & B \\ 0 & I \end{bmatrix}$$

and so $\det Dx(0) = \det(A) \neq 0$. By the inverse function theorem, \bar{x} is an invertible germ with inverse \bar{x}^{-1} . Choose a representative for \bar{x}^{-1} which we by a slight abuse of notation will call x^{-1} . Since for sufficiently small $t \in M = \mathbf{R}^m$ we have

$$(f_1(t), \dots, f_n(t)) = f(t) = f x^{-1} x(t) = f x^{-1}(f_1(t), \dots, f_r(t), t_{r+1}, \dots, t_m)$$

we see that

$$f x^{-1}(q) = (q_1, \dots, q_r, f_{r+1} x^{-1}(q), \dots, f_n x^{-1}(q))$$

and we have proven the first part of the rank theorem.

For the second half, assume $rkDf(q) = r$ for all q . Since \bar{x} is invertible

$$D(fx^{-1})(q) = Df(x^{-1}(q))D(x^{-1})(q)$$

also has rank r for all q in the domain of definition. Note that

$$D(fx^{-1})(q) = \begin{bmatrix} I & 0 \\ \dots\dots\dots & \dots\dots\dots \\ [D_j(f_i x^{-1})(q)]_{\substack{i=r+1,\dots,n \\ j=1,\dots,m}} \end{bmatrix}$$

so since the rank is exactly r we must have that the lower right hand $(n-r) \times (m-r)$ -matrix

$$[D_j(f_i x^{-1})(q)]_{\substack{r+1 \leq i \leq n \\ r+1 \leq j \leq m}}$$

is the zero matrix (which says that “ $f_i x^{-1}$ does not depend on the last $m - r$ coordinates for $i > r$ ”). Define $\bar{y}: (\mathbf{R}^n, 0) \rightarrow (\mathbf{R}^n, 0)$ by setting

$$y(q) = (q_1, \dots, q_r, q_{r+1} - f_{r+1}x^{-1}(\bar{q}), \dots, q_n - f_nx^{-1}(\bar{q}))$$

where $\bar{q} = (q_1, \dots, q_r, 0, \dots, 0)$. Then

$$Dy(q) = \begin{bmatrix} I & 0 \\ ? & I \end{bmatrix}$$

so \bar{y} is invertible and $\overline{yfx^{-1}}$ is represented by

$$\begin{aligned} q = (q_1, \dots, q_m) &\mapsto (q_1, \dots, q_r, f_{r+1}x^{-1}(q) - f_{r+1}x^{-1}(\bar{q}), \dots, f_nx^{-1}(q) - f_nx^{-1}(\bar{q})) \\ &= (q_1, \dots, q_r, 0, \dots, 0) \end{aligned}$$

where the last equation holds since $D_j(f_i x^{-1})(q) = 0$ for $r < i \leq n$ and $r < j \leq m$ so $\dots, f_nx^{-1}(q) - f_nx^{-1}(\bar{q}) = 0$ for $r < i \leq n$ for q close to the origin. ■

The **proof** of the rank theorem has the following corollary. It treats the case when the rank is maximal (and hence constant). Note that the permutations have been removed from the first part. Also note that if $f: M \rightarrow N$ has rank $dim(N)$, then $dim(N) \leq dim(M)$ and if f has rank $dim(M)$ then $dim(M) \leq dim(N)$.

Corollary 6.3.2 *Let M and N be smooth manifolds of dimension $dim(M) = m$ and $dim(N) = n$.*

Let $\bar{f}: (M, p) \rightarrow (N, f(p))$ be a germ of rank n . Then there exist a chart germ

$$\bar{x}: (M, p) \rightarrow (\mathbf{R}^m, x(p))$$

such that for any chart germ

$$\bar{y}: (N, f(p)) \rightarrow (\mathbf{R}^n, yf(p))$$

$$yfx^{-1}(q) = (q_1, \dots, q_n)$$

for all $q = (q_1, \dots, q_m)$ sufficiently close to $x(p)$.

If \bar{f} has rank m , then there exist chart germs

$$\bar{x}: (M, p) \rightarrow (\mathbf{R}^m, x(p)) \text{ and } \bar{y}: (N, f(p)) \rightarrow (\mathbf{R}^n, yf(p))$$

such that

$$yfx^{-1}(q) = (q_1, \dots, q_m, 0, \dots, 0)$$

for all $q = (q_1, \dots, q_{\dim(M)})$ sufficiently close to $x(p)$.

Exercise 6.3.3 Let $f: M \rightarrow M$ be smooth such that $f \circ f = f$ and M connected. Prove that $f(M) \subseteq M$ is a submanifold. If you like point-set topology, prove that $f(M) \subseteq M$ is closed.

6.4 Regular values

Since the rank can only increase locally, there are certain situations where constant rank is guaranteed, namely when the rank is maximal.

Definition 6.4.1 A smooth map $f: M \rightarrow N$ is

a *submersion* if $rkT_p f = \dim N$ (that is $T_p f$ is surjective)

an *immersion* if $rkT_p f = \dim M$ ($T_p f$ is injective)

for all $p \in M$.

Note 6.4.2 To say that a map $f: M \rightarrow N$ is a submersion is equivalent to claiming that all points $p \in M$ are regular ($T_p f$ is surjective), which again is equivalent to claiming that all $q \in N$ are regular values (values that are not hit are regular by definition).

Theorem 6.4.3 *Let*

$$f: M \rightarrow N$$

be a smooth map where M is $n + k$ -dimensional and N is n -dimensional. If $q = f(p)$ is a regular value, then

$$f^{-1}(q) \subseteq M$$

is a k -dimensional smooth submanifold.

Proof: We must display a chart (x, W) such that $x(W \cap f^{-1}(q)) = x(W) \cap (\mathbf{R}^k \times \{0\})$.

Since p is regular, the rank of f must be n in a neighborhood of p , so by the rank theorem 6.3.1, there are charts (x, U) and (y, V) around p and q such that $x(p) = 0$, $y(q) = 0$ and

$$yfx^{-1}(t_1, \dots, t_{n+k}) = (t_1, \dots, t_n), \text{ for } t \in x(U \cap f^{-1}(V))$$

Let $W = U \cap f^{-1}(V)$, and note that $f^{-1}(q) = (yf)^{-1}(0)$. Then

$$\begin{aligned} x(W \cap f^{-1}(q)) &= x(W) \cap (yfx^{-1})^{-1}(0) \\ &= \{(0, \dots, 0, t_{n+1}, \dots, t_{n+k}) \in x(W)\} \\ &= (\{0\} \times \mathbf{R}^k) \cap x(W) \end{aligned}$$

and so (permuting the coordinates) $f^{-1}(q) \subseteq M$ is a k -dimensional submanifold as claimed. ■

Exercise 6.4.4 Give a new proof which shows that $S^n \subset \mathbf{R}^{n+1}$ is a smooth submanifold.

Note 6.4.5 Not all submanifolds can be realized as the inverse image of a regular value of some map (e.g. the zero section in the canonical line bundle $\eta_1 \rightarrow S^1$ can not, see 6.4.24), but the theorem still gives a rich source of important examples of submanifolds.

Example 6.4.6 The example 6.1.8 gives two examples illustrating the theorem. The robot example is another example. In that example we considered a function

$$f: S^1 \times S^1 \rightarrow \mathbf{R}^1$$

and found three critical values.

To be more precise:

$$f(e^{i\theta}, e^{i\phi}) = |3 - e^{i\theta} - e^{i\phi}|$$

and so (using charts corresponding to the angles: conveniently all charts give the same formulas in this example) the Jacobi matrix at $(e^{i\theta}, e^{i\phi})$ equals

$$\frac{1}{f(e^{i\theta}, e^{i\phi})} [3 \sin \theta - \cos \phi \sin \theta + \sin \phi \cos \theta, 3 \sin \phi - \cos \theta \sin \phi + \sin \theta \cos \phi]$$

(exercise: do this). The rank is one, unless both coordinates are zero, in which case we get that we must have $\sin \theta = \sin \phi = 0$, which leaves the points

$$(1, 1), \quad (-1, -1), \quad (1, -1), \quad \text{and } (-1, 1)$$

giving the critical values 1, 5 and (twice) 3.

Exercise 6.4.7 Fill out the details in the robot example. Then do it in three dimensions.

Example 6.4.8 Consider the *special linear group*

$$SL_n(\mathbf{R}) = \{A \in GL_n(\mathbf{R}) \mid \det(A) = 1\}$$

We show that $SL_2(\mathbf{R})$ is a 3-dimensional manifold. The determinant function is given by

$$\begin{aligned} \det: M_2(\mathbf{R}) &\rightarrow \mathbf{R} \\ A = \begin{bmatrix} a_{11} & a_{12} \\ a_{21} & a_{22} \end{bmatrix} &\mapsto \det(A) = a_{11}a_{22} - a_{12}a_{21} \end{aligned}$$

and so with the obvious coordinates $M_2(\mathbf{R}) \cong \mathbf{R}^4$ (sending A to $[a_{11} \ a_{12} \ a_{21} \ a_{22}]^t$) we have that

$$D(\det)(A) = [a_{22} \ -a_{21} \ -a_{12} \ a_{11}]$$

Hence the determinant function has rank 1 at all matrices, except the zero matrix, and in particular 1 is a regular value.

Exercise 6.4.9 Show that $SL_2(\mathbf{R})$ is diffeomorphic to $S^1 \times \mathbf{R}^2$.

Exercise 6.4.10 If you have the energy, you may prove that $SL_n(\mathbf{R})$ is an $(n^2 - 1)$ -dimensional manifold.

Example 6.4.11 The subgroup $O(n) \subseteq GL_n(\mathbf{R})$ of *orthogonal matrices* is a submanifold of dimension $\frac{n(n-1)}{2}$.

To see this, recall that $A \in GL_n(\mathbf{R})$ is orthogonal iff $A^t A = I$. Note that $A^t A$ is always symmetric. The space $Sym(n)$ of all symmetric matrices is diffeomorphic to $\mathbf{R}^{n(n+1)/2}$ (the entries on and above the diagonal are arbitrary). We define a map

$$\begin{aligned} f: GL_n(\mathbf{R}) &\rightarrow Sym(n) \\ A &\mapsto A^t A \end{aligned}$$

which is smooth (since matrix multiplication and transposition is smooth), and such that

$$O(n) = f^{-1}(I)$$

We must show that I is a regular value, and we offer two proofs, one computational using the Jacobi matrix, and one showing more directly that $T_A f$ is surjective for all $A \in O(n)$.

We present both proofs, the first one since it is very concrete, and the second one since it is short and easy to follow.

First the Jacobian argument. We use the usual chart on $GL_n(\mathbf{R}) \subseteq M_n(\mathbf{R}) \cong \mathbf{R}^{n^2}$ by listing the entries in lexicographical order, and the chart $pr: Sym(n) \cong \mathbf{R}^{n(n+1)/2}$ with $pr_{kl}[a_{ij}] = a_{kl}$ (also in lexicographical order) only defined for $1 \leq i \leq j \leq n$. Then $pr_{k<l}f([a_{ij}]) = \sum_{k+1}^n a_{ik}a_{jk}$, and a straight forward calculation yields that if $A = [a_{ij}]$ then

$$D_{kl}pr_{i<j}f(A) = \begin{cases} a_{jl} & k = i < j \\ a_{il} & i < j = k \\ 2a_{il} & i = j = k \\ 0 & \text{otherwise} \end{cases}$$

In particular

$$D_{kl}pr_{i<j}f(I) = \begin{cases} 1 & k = i < j = l \\ 1 & l = i < j = k \\ 2 & i = j = k = l \\ 0 & \text{otherwise} \end{cases}$$

and $rkDf(I) = n(n+1)/2$ since $Df(I)$ is on echelon form, with no vanishing rows (except for $n=2$ and $n=3$ the Jacobi matrices are

$$\begin{bmatrix} 2 & & & \\ & 1 & 1 & \\ & & 1 & \\ & & & 2 \end{bmatrix}, \text{ and } \begin{bmatrix} 2 & & & & & \\ & 1 & & 1 & & \\ & & 1 & & & \\ & & & 2 & & \\ & & & & 1 & 1 \\ & & & & & 2 \end{bmatrix}$$

(in the first matrix the columns are the partial derivatives in the 11, 12, 21 and 22-variable, and the rows are the projection on the 11 12 and 22-factor. Likewise in the second one)).

For any $A \in GL_n(\mathbf{R})$ we define the diffeomorphism

$$L_A: GL_n(\mathbf{R}) \rightarrow GL_n(\mathbf{R})$$

by $L_A(B) = A \cdot B$. Note that if $A \in O(n)$ then

$$f(L_A(B)) = f(AB) = (AB)^t AB = B^t A^t AB = B^t B = f(B)$$

and so by the chain rule and the fact that $D(L_A)(B) = A$ we get that

$$Df(I) = D(fL_A)(I) = D(f)(L_A I)D(L_A)(I) = D(f)(A)A$$

implying that $rkD(f)(A) = n(n+1)/2$ for all $A \in O(n)$. This means that A is a regular point for all $A \in O(n) = f^{-1}(I)$, and so I is a regular value, and $O(n)$ is an

$$n^2 - n(n+1)/2 = n(n-1)/2$$

dimensional submanifold.

For the other proof of the fact that I is a regular value, notice that all tangent vectors in $T_A\mathrm{GL}_n(\mathbf{R}) = T_AM_n(\mathbf{R})$ are in the equivalence class of a linear curve

$$\nu_B(s) = A + sB, \quad B \in M_n(\mathbf{R}), \quad s \in \mathbf{R}$$

We have that

$$f\nu_B(s) = (A + sB)^t(A + sB) = A^tA + s(A^tB + B^tA) + s^2B^tB$$

and so

$$T_Af[\nu_B] = [f\nu_B] = [\gamma_B]$$

where $\gamma_B(s) = A^tA + s(A^tB + B^tA)$. Similarly, all tangent vectors in $T_I\mathrm{Sym}(n)$ are in the equivalence class of a linear curve

$$\alpha_C(s) = I + sC$$

for C a symmetric matrix. If A is orthogonal, we see that $\gamma_{\frac{1}{2}AC} = \alpha_C$, and so $T_Af[\nu_{\frac{1}{2}AC}] = [\alpha_C]$, and T_Af is surjective. Since this is true for all $A \in O(n)$ we get that I is a regular value.

Exercise 6.4.12 Consider the inclusion $O(n) \subseteq M_n(\mathbf{R})$, giving a description of the tangent bundle of $O(n)$ along the lines of corollary 5.5.12. Show that under the isomorphism

$$TM_n(\mathbf{R}) \cong M_n(\mathbf{R}) \times M_n(\mathbf{R}), \quad [\gamma] \leftrightarrow (\gamma(0), \gamma'(0))$$

the tangent bundle of $O(n)$ corresponds to the projection on the first factor

$$E = \{(g, A) \in O(n) \times M_n(\mathbf{R}) \mid A^t = -g^tAg^t\} \rightarrow O(n).$$

This also shows that $O(n)$ is parallelizable, since we get an obvious bundle isomorphism induced by

$$E \rightarrow O(n) \times \{B \in M_n(\mathbf{R}) \mid B^t = -B^t\}, \quad (g, A) \mapsto (g, g^{-1}A)$$

(a matrix B satisfying $B^t = -B^t$ is called a *skew matrix*).

Note 6.4.13 The multiplication

$$O(n) \times O(n) \rightarrow O(n)$$

is smooth (since multiplication of matrices is smooth in $M_n(\mathbf{R}) \cong \mathbf{R}^{n^2}$, and 3.5.14), and so $O(n)$ is a Lie group. The same of course applies to $SL_n(\mathbf{R})$.

Exercise 6.4.14 Prove that

$$\begin{aligned} \mathbf{C} &\rightarrow M_2(\mathbf{R}) \\ x + iy &\mapsto \begin{bmatrix} x & -y \\ y & x \end{bmatrix} \end{aligned}$$

defines an imbedding. More generally it defines an imbedding

$$M_n(\mathbf{C}) \rightarrow M_n(M_2(\mathbf{R})) \cong M_{2n}(\mathbf{R})$$

Show also that this imbedding sends “conjugate transpose” to “transpose” and “multiplication” to “multiplication”.

Exercise 6.4.15 Prove that the *unitary group*

$$U(n) = \{A \in \mathrm{GL}_n(\mathbf{C}) \mid \bar{A}^t A = I\}$$

is a Lie group of dimension n^2 .

Exercise 6.4.16 Prove that $O(n)$ is compact and has two connected components. The component consisting of matrices of determinant 1 is called $SO(n)$, the *special orthogonal group*.

Note 6.4.17 $SO(2)$ is diffeomorphic to S^1 (prove this), and $SO(3)$ is diffeomorphic to the real projective 3-space (don’t prove that).

Note 6.4.18 It is a beautiful fact that if G is a Lie group (e.g. $\mathrm{GL}_n(\mathbf{R})$) and $H \subseteq G$ is a closed subset containing the identity, and which is closed under multiplication, then $H \subseteq G$ is a “Lie subgroup”. We will not prove this fact, (see e.g. Spivak’s book I, theorem 10.15), but note that it implies that **all** matrix groups such as $O(n)$ are Lie groups since $\mathrm{GL}_n(\mathbf{R})$ is.

Exercise 6.4.19 A k -frame in \mathbf{R}^n is a k -tuple of orthonormal vectors in \mathbf{R}^n . Define a *Stiefel manifold* V_n^k as the subset

$$V_n^k = \{k\text{-frames in } \mathbf{R}^n\}$$

of \mathbf{R}^{nk} . Show that V_n^k is a compact smooth $nk - \frac{k(k+1)}{2}$ -dimensional manifold.

Note 6.4.20 In the literature you will often find a different definition, where a k -frame is just a k -tuple of linearly independent vectors. Then the Stiefel manifold is an open subset of the $M_{n \times k}(\mathbf{R})$, and so is clearly a smooth manifold – but this time of dimension nk .

A k -frame defines a k -dimensional linear subspace of \mathbf{R}^n . The *Grassmann manifold* G_n^k have as underlying set the set of k -dimensional linear subspaces of \mathbf{R}^n , and is topologized as the quotient space of the Stiefel manifold. The Grassmann manifolds are important since they classify vector bundles.

Exercise 6.4.21 Let P_n be the space of degree n polynomials. Show that the space of solutions to the equation

$$(y'')^2 - y' + y(0) + xy'(0) = 0$$

is a 1-dimensional submanifold of P_3 .

Exercise 6.4.22 Make a more interesting exercise along the lines of the previous, and solve it.

Exercise 6.4.23 Let $A \in M_n(\mathbf{R})$ be a symmetric matrix. For what values of $a \in \mathbf{R}$ is the quadric

$$M_a^A = \{p \in \mathbf{R}^n \mid p^t A p = a\}$$

an $n - 1$ -dimensional smooth manifold?

Exercise 6.4.24 Consider the canonical line bundle

$$\eta_1 \rightarrow S^1$$

Prove that there is no smooth map $f: \eta_1 \rightarrow \mathbf{R}$ such that the zero section is the inverse image of a regular value of f .

More generally, show that there is no map $f: \eta_1 \rightarrow N$ for any manifold N such that the zero section is the inverse image of a regular value of f .

Exercise 6.4.25 In a chemistry book I found van der Waal's equation, which gives a relationship between the temperature T , the pressure p and the volume V , which supposedly is somewhat more accurate than the ideal gas law $pV = nRT$ (n is the number of moles of gas, R is a constant). Given the relevant positive constants a and b , prove that the set of points $(p, V, T) \in (0, \infty) \times (nb, \infty) \times (0, \infty)$ satisfying the equation

$$\left(p - \frac{n^2 a}{V^2}\right)(V - nb) = nRT$$

is a smooth submanifold of \mathbf{R}^3 .

Exercise 6.4.26 Consider the set $LF_{n,k}$ of *labelled flexible n -gons* in \mathbf{R}^k . A labelled flexible n -gon is what you get if you join $n > 2$ straight lines of unit length to a closed curve and label the vertices from 1 to n .

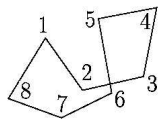

A labelled flexible 8-gon in \mathbf{R}^2 .

Let n be odd and $k = 2$. Show that $LF_{n,2}$ is a smooth submanifold of $\mathbf{R}^2 \times (S^1)^{n-1}$ of dimension n .

Exercise 6.4.27 Prove that the set of *non-self-intersecting* flexible n -gons in \mathbf{R}^2 is a manifold.

6.5 Immersions and imbeddings

We are finally closing in on the promised “real” definition of submanifolds, or rather, of imbeddings. The condition of being an immersion is a readily checked property, since we only have to check the derivatives in every point. The rank theorem states that in some sense “locally” immersions are imbeddings. But how much more do we need? Obviously, an imbedding is injective.

Something more is needed, as we see from the following example

Example 6.5.1 Consider the injective smooth map

$$f: (0, 3\pi/4) \rightarrow \mathbf{R}^2$$

given by

$$f(t) = \sin(2t)(\cos t, \sin t)$$

Then

$$Df(t) = [(1 - 3\sin^2 t) \cos t, (3\cos^2 t - 1) \sin t]$$

is never zero and f is an immersion.

However,

$$(0, 3\pi/4) \rightarrow \text{im}\{f\}$$

is not a homeomorphism where

$$\text{im}\{f\} = f((0, 3\pi/4)) \subseteq \mathbf{R}^2$$

has the subspace topology. For, if it were a homeomorphism, then

$$f((\pi/4, 3\pi/4)) \subseteq \text{im}\{f\}$$

would be open (for the inverse to be continuous). But any open ball around $(0, 0) = f(\pi/2)$ in \mathbf{R}^2 must contain a piece of $f((0, \pi/4))$, so $f((\pi/4, 3\pi/4)) \subseteq \text{im}\{f\}$ is not open.

Hence f is not an imbedding.

Exercise 6.5.2 Let

$$\mathbf{R} \amalg \mathbf{R} \rightarrow \mathbf{R}^2$$

be defined by sending x in the first summand to $(x, 0)$ and y in the second summand to $(0, e^y)$. This is an injective immersion, but not an imbedding.

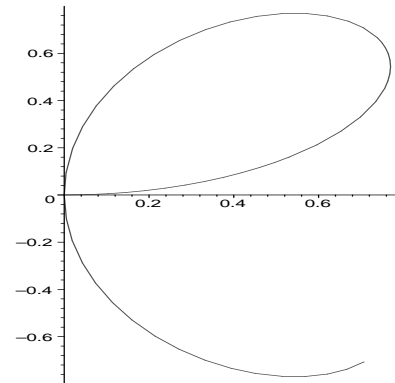

The image of f is a subspace of \mathbf{R}^2 .

Exercise 6.5.3 Let

$$\mathbf{R} \amalg S^1 \rightarrow \mathbf{C}$$

be defined by sending x in the first summand to $(1 + e^x)e^{ix}$ and being the inclusion $S^1 \subseteq \mathbf{C}$ on the second summand. This is an injective immersion, but not an imbedding.

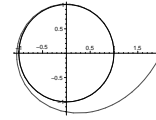

The image is not a submanifold of \mathbf{C} .

But, strangely enough these examples exhibit the only thing that can go wrong: if an injective immersion is to be an imbedding, the map to the image has got to be a homeomorphism.

Theorem 6.5.4 *Let $f: M \rightarrow N$ be an immersion such that the induced map*

$$M \rightarrow \text{im}\{f\}$$

is a homeomorphism where $\text{im}\{f\} = f(M) \subseteq N$ has the subspace topology, then f is an imbedding.

Proof: Let $p \in M$. The rank theorem says that there are charts

$$x_1: U_1 \rightarrow U'_1 \subseteq \mathbf{R}^n$$

and

$$y_1: V_1 \rightarrow V'_1 \subseteq \mathbf{R}^{n+k}$$

with $x_1(p) = 0$ and $y_1(f(p)) = 0$ such that

$$y_1 f x_1^{-1}(t) = (t, 0) \in \mathbf{R}^n \times \mathbf{R}^k = \mathbf{R}^{n+k}$$

for all $t \in x_1(U_1 \cap f^{-1}(V_1))$.

Since V'_1 is open, it contains open rectangles around the origin. Choose one such rectangle (see the picture below)

$$V'_2 = U' \times B \subseteq ((U'_1 \cap x_1 f^{-1}(V_1)) \times \mathbf{R}^k) \cap V'_1 \subseteq \mathbf{R}^n \times \mathbf{R}^k$$

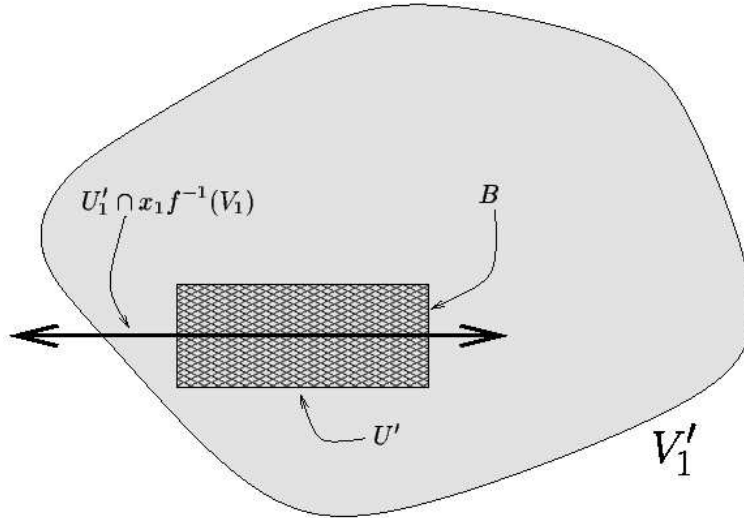

Let $U = x_1^{-1}(U')$, $x = x_1|_U$ and $V_2 = y_1^{-1}(V'_2)$.

Since $M \rightarrow f(M)$ is a homeomorphism, $f(U)$ is an open subset of $f(M)$, and since $f(M)$ has the subspace topology, $f(U) = W \cap f(M)$ where W is an open subset of N (here is the crucial point where complications as in example 6.5.1 are excluded: there are no other “branches” of $f(M)$ showing up in W).

Let $V = V_2 \cap W$, $V' = V'_2 \cap y_1(W)$ and $y = y_1|_V$.

Then we see that $f(M) \subseteq N$ is a submanifold ($y(f(M) \cap V) = yf(U) = (\mathbf{R}^n \times \{0\}) \cap V'$), and $M \rightarrow f(M)$ is a bijective local diffeomorphism (the constructed charts show that both f and its inverse are smooth around every point), and hence a diffeomorphism. ■

We note the following useful corollary:

Corollary 6.5.5 *Let $f: M \rightarrow N$ be an injective immersion from a compact manifold M . Then f is an imbedding.*

Proof: We only need to show that the continuous map $M \rightarrow f(M)$ is a homeomorphism. It is injective since f is, and clearly surjective. But from point set topology (theorem 10.7.8) we know that it must be a homeomorphism since M is compact and $f(M)$ is Hausdorff ($f(M)$ is Hausdorff since it is a subspace of the Hausdorff space N). ■

Exercise 6.5.6 Let $a, b \in \mathbf{R}$, and consider the map

$$f_{a,b}: \mathbf{R} \rightarrow S^1 \times S^1$$

$$t \mapsto (e^{iat}, e^{ibt})$$

Show that $f_{a,b}$ is an immersion if either a or b is different from zero. Show that $f_{a,b}$ factors through an imbedding $S^1 \rightarrow S^1 \times S^1$ iff either $b = 0$ or a/b is rational.

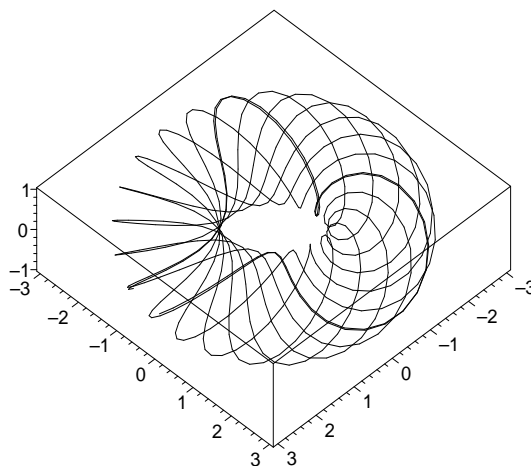

Part of the picture if $a/b = \pi$ (this goes on forever)

Exercise 6.5.7 Consider smooth maps

$$M \xrightarrow{i} N \xrightarrow{j} L$$

Show that if the composite ji is an imbedding, then i is an imbedding.

6.6 Sard's theorem

For reference we cite Sard's theorem, which says that regular values are the common state of affairs (in technical language: critical values have "measure zero" while regular values are "dense"). Proofs can be found in many references, for instance in Milnor's book [M]. There are many versions, but we list only the following simple form:

Theorem 6.6.1 *Let $f: M \rightarrow N$ be a smooth map and $U \subseteq N$ an open subset. Then U contains a regular value for f .*

Chapter 7

Partition of unity

7.1 Definitions

In this chapter we define partitions of unity. They are smooth devices making it possible to patch together some types of local information into global information. They come in the form of “bump functions” such that around any given point there are only finitely many of them that are nonzero, and such that the sum of their values is 1.

This can be applied for instance to patch together the nice local structure of a manifold to an imbedding into an Euclidean space, construct sensible metrics on the tangent spaces (so-called Riemannian metrics), and in general to construct smooth functions with desirable properties.

Definition 7.1.1 Let \mathcal{U} be an open covering of a space X . We say that \mathcal{U} is *locally finite* if each $p \in X$ has a neighborhood which intersects only finitely many sets in \mathcal{U} .

Definition 7.1.2 Let X be a space. The *support* of a function $f : X \rightarrow \mathbf{R}$ is the closure of the subset of X with nonzero values, i.e.

$$\text{supp}(f) = \overline{\{x \in X \mid f(x) \neq 0\}}$$

Definition 7.1.3 A family of continuous function

$$\phi_\alpha : X \rightarrow [0, 1]$$

is called a *partition of unity* if

the collection of subsets $\{ \{p \in X | \phi_\alpha(p) \neq 0\} \}$ is a locally finite open covering of X ,
for all $p \in X$ the (finite) sum $\sum_\alpha \phi_\alpha(p) = 1$.

The partition of unity is said to be *subordinate* to a covering \mathcal{U} of X if in addition

for every ϕ_α there is a member U of \mathcal{U} such that $\text{supp}(\phi_\alpha) \subseteq U$.

Partitions of unity are used to patch together local structures to global ones.

Given a space that is not too big and complicated (for instance if it is a compact manifold) it may not be surprising that we can build a partition of unity on it. What is more surprising is that on smooth manifolds we can build **smooth** partitions of unity (that is, all the ϕ_α 's are smooth).

In order to this we need smooth bump functions.

7.2 Smooth bump functions

Let $\lambda : \mathbf{R} \rightarrow \mathbf{R}$ be defined by

$$\lambda(t) = \begin{cases} 0 & \text{for } t \leq 0 \\ e^{-1/t^2} & \text{for } t > 0 \end{cases}$$

This is a smooth function (note that all derivatives in zero are zero: it is definitely not analytic) with values between zero and one.

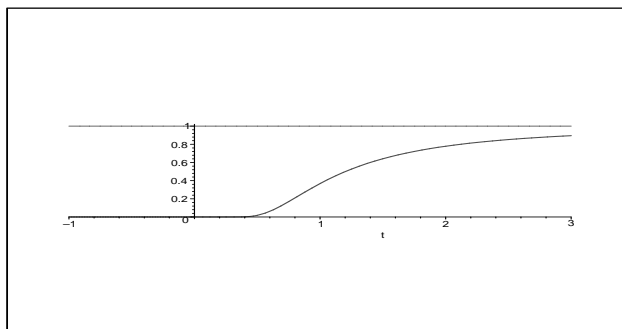

Exercise 7.2.1 Prove that λ is smooth.

For $0 < \epsilon$, let $\beta_\epsilon : \mathbf{R} \rightarrow \mathbf{R}$ be given by

$$\beta_\epsilon(t) = \lambda(t) \cdot \lambda(\epsilon - t)$$

For $\epsilon = 1$ it looks like

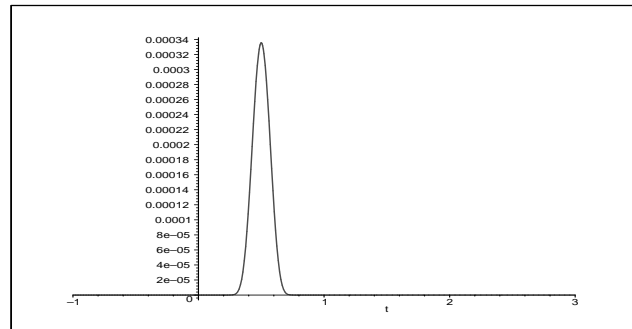

It is a small bump, but it is nonzero between 0 and ϵ , and so we may define the function $\alpha_\epsilon : \mathbf{R} \rightarrow \mathbf{R}$ which ascends from zero to one smoothly between zero and ϵ by means of

$$\alpha_\epsilon(t) = \frac{\int_0^x \beta_\epsilon(x) dx}{\int_0^\epsilon \beta_\epsilon(x) dx}$$

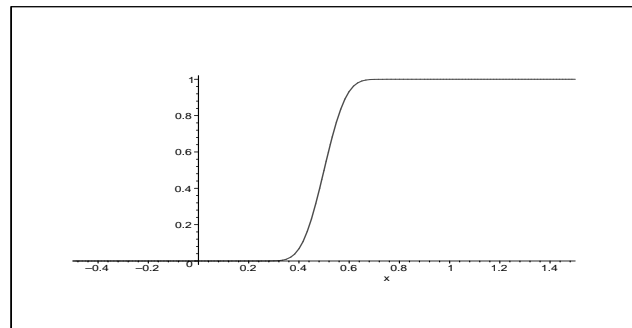

and finally the ultimate bump function $\gamma_{(r,\epsilon)} : \mathbf{R}^n \rightarrow \mathbf{R}$ where $0 < r$ given by

$$\gamma_{(r,\epsilon)}(x) = 1 - \alpha_\epsilon(|x| - r)$$

which is zero $|x| \geq r + \epsilon$ and one for $|x| \leq r$.

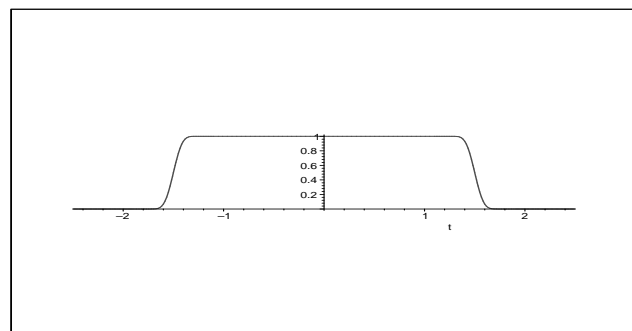

Example 7.2.2 Smooth bump functions are very handy, for instance if you want to join curves in a smooth fashion (for instance if you want to design smooth highways!) They also allow you to drive smoothly on a road with corners: the curve $\gamma : \mathbf{R} \rightarrow \mathbf{R}^2$ given by $\gamma(t) = (te^{-1/t^2}, |te^{-1/t^2}|)$ is smooth, although its image is not.

Exercise 7.2.3 Show that any function germ $\bar{\phi}: (M, p) \rightarrow (\mathbf{R}, \phi(p))$ has a smooth representative $\phi: M \rightarrow \mathbf{R}$.

Exercise 7.2.4 Let M and N be smooth manifolds and $f: M \rightarrow N$ a continuous map. Show that f is smooth if for all smooth $\phi: N \rightarrow \mathbf{R}$ the composite $\phi f: M \rightarrow \mathbf{R}$ is smooth.

Exercise 7.2.5 Show that any smooth vector bundle $E \rightarrow [0, 1]$ is trivial (smooth on the boundary means what you think it does: don't worry).

Exercise 7.2.6 Show that any 1-dimensional smooth vector bundle (also called *line bundle*) $E \rightarrow S^1$ is either trivial, or $E \cong \eta_1$. Show the analogous statement for n -dimensional vector bundles.

7.3 Refinements of coverings

If $0 < r$ let $E^n(r) = \{x \in \mathbf{R}^n \mid |x| < r\}$ be the open n -dimensional ball of radius r centered at the origin.

Lemma 7.3.1 *Let M be an n -dimensional manifold. Then there is a countable atlas \mathcal{A} such that $x(U) = E^n(3)$ for all $(x, U) \in \mathcal{A}$ and such that*

$$\bigcup_{(x,U) \in \mathcal{A}} x^{-1}(E^n(1)) = M$$

If M is smooth all charts may be chosen to be smooth.

Proof: Let \mathcal{B} be a countable basis for the topology on M . For every $p \in M$ there is a chart (x, U) with $x(p) = 0$ and $x(U) = E^n(3)$. The fact that \mathcal{B} is a basis for the topology gives that there is a $V \in \mathcal{B}$ with

$$p \in V \subseteq x^{-1}(E^n(1))$$

For each such $V \in \mathcal{B}$ choose just **one** such chart (x, U) with $x(U) = E^n(3)$ and

$$x^{-1}(0) \in V \subseteq x^{-1}(E^n(1))$$

The set of these charts is the desired countable \mathcal{A} .

If M were smooth we just append “smooth” in front of every “chart” in the proof above. ■

Lemma 7.3.2 *Let M be a manifold. Then there is a sequence $A_1 \subseteq A_2 \subseteq A_3 \subseteq \dots$ of compact subsets of M such that for every $i \geq 1$ the compact subset A_i is contained in the interior of A_{i+1} and such that $\bigcup_i A_i = M$*

Proof: Let $\{(x_i, U_i)\}_{i=1, \dots}$ be the countable atlas of the lemma above, and let

$$A_k = \bigcup_{i=1}^k x_i^{-1}(\overline{E^n(2 - 1/k)})$$

■

Definition 7.3.3 Let \mathcal{U} be an open covering of a space X . We say that another cover \mathcal{V} is a *refinement* of \mathcal{U} if every member of \mathcal{V} is contained in a member of \mathcal{U} .

Definition 7.3.4 Let M be a manifold and let \mathcal{U} be an open cover of M . A *good atlas subordinate* to \mathcal{U} is a countable atlas \mathcal{A} on M such that

- 1) the cover $\{V\}_{(x,V) \in \mathcal{A}}$ is a locally finite refinement of \mathcal{U} ,
- 2) $x(V) = E^n(3)$ for each $(x, V) \in \mathcal{A}$ and
- 3) $\bigcup_{(x,V) \in \mathcal{A}} x^{-1}(E^n(1)) = M$.

Theorem 7.3.5 Let M be a manifold and let \mathcal{U} be an open cover of M . Then there exists a good atlas \mathcal{A} subordinate to \mathcal{U} . If M is smooth, then \mathcal{A} may be chosen smooth too.

Proof: The remark about the smooth situation will follow by the same proof. Choose a sequence

$$A_1 \subseteq A_2 \subseteq A_3 \subseteq \dots$$

of compact subsets of M such that for every $i \geq 1$ the compact subset A_i is contained in the interior of A_{i+1} and such that $\bigcup_i A_i = M$.

For every point

$$p \in A_{i+1} - \text{int}(A_i)$$

choose a $U_p \in \mathcal{U}$ with $p \in U_p$ and choose a chart (y_p, W_p) such that $p \in W_p$ and $y_p(p) = 0$.

Since $\text{int}(A_{i+2}) - A_{i-1}$, $y_p(W_p)$ and U_p are open there is an $\epsilon_p > 0$ such that

$$E^n(\epsilon_p) \subseteq y_p(W_p), \quad y_p^{-1}(E^n(\epsilon_p)) \subseteq (\text{int}(A_{i+2}) - A_{i-1}) \cap U_p$$

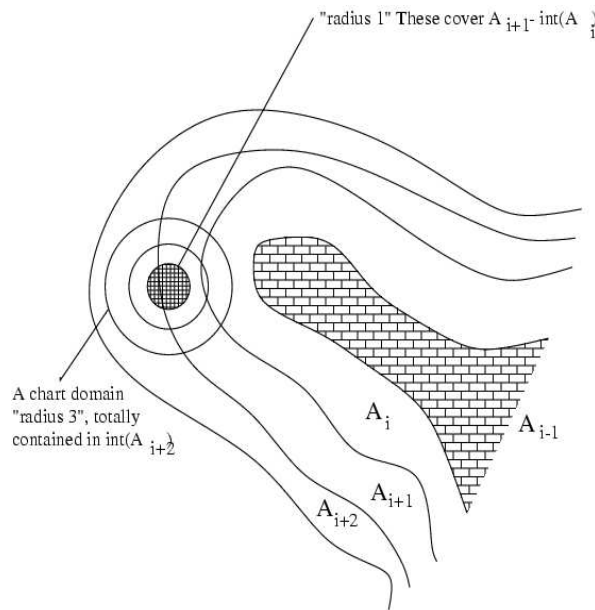

The positioning of the charts

Let $V_p = y_p^{-1}(E^n(\epsilon_p))$ and

$$x_p = \frac{3}{\epsilon_p} y_p|_{V_p} : V_p \rightarrow E^n(3)$$

Then $\{x_p^{-1}(E^n(1))\}_p$ cover the compact set $A_{i+1} - \text{int}(A_i)$, and we may choose a finite set of points p_1, \dots, p_k such that

$$\{x_{p_j}^{-1}(E^n(1))\}_{j=1, \dots, k}$$

still cover $A_{i+1} - \text{int}(A_i)$.

Letting \mathcal{A} consist of the (x_{p_j}, V_{p_j}) as i and j vary we have proven the theorem. ■

7.4 Existence of smooth partitions of unity on smooth manifolds.

Theorem 7.4.1 *Let M be a differentiable manifold, and let \mathcal{U} be a covering of M . Then there is a smooth partition of unity of M subordinate to \mathcal{U} .*

Proof: To the good atlas $\mathcal{A} = \{(x_i, V_i)\}$ subordinate to \mathcal{U} constructed in theorem 7.3.5 we may assign functions $\{\psi_i\}$ as follows

$$\psi_i(q) = \begin{cases} \gamma_{(1,1)}(x_i(q)) & \text{for } q \in V_i = x_i^{-1}(E^n(3)) \\ 0 & \text{otherwise} \end{cases}$$

The function ψ_i has support $x_i^{-1}(E^n(2))$ and is obviously smooth. Since $\{V_i\}$ is locally finite, around any point $p \in M$ there is an open set such there are only finitely many ψ_i 's with nonzero values, and hence the expression

$$\sigma(p) = \sum_i \psi_i(p)$$

defines a smooth function $M \rightarrow \mathbf{R}$ with everywhere positive values. The partition of unity is then defined by

$$\phi_i(p) = \psi_i(p)/\sigma(p)$$

■

7.5 Application: every compact smooth manifold may be imbedded in an Euclidean space

As an application, we will prove the easy version of Whitney's imbedding theorem. The hard version states that any manifold may be imbedded in the Euclidean space of the double dimension. We will only prove:

Theorem 7.5.1 *Let M be a compact smooth manifold. Then there is an imbedding $M \rightarrow \mathbf{R}^N$ for some N .*

Proof: Assume M has dimension m . Choose a finite good atlas

$$\mathcal{A} = \{x_i, V_i\}_{i=1, \dots, r}$$

Define $\psi_i: M \rightarrow \mathbf{R}$ and $k_i: M \rightarrow \mathbf{R}^m$ by

$$\psi_i(p) = \begin{cases} \gamma_{(1,1)}(x_i(p)) & \text{for } p \in V_i \\ 0 & \text{otherwise} \end{cases}$$

$$k_i(p) = \begin{cases} \psi_i(p) \cdot x_i(p) & \text{for } p \in V_i \\ 0 & \text{otherwise} \end{cases}$$

Consider the map

$$f: M \rightarrow \prod_{i=1}^r \mathbf{R}^m \times \prod_{i=1}^r \mathbf{R}$$

$$p \mapsto ((k_1(p), \dots, k_r(p)), (\psi_1(p), \dots, \psi_r(p)))$$

We shall prove that this is an imbedding by showing that it is an immersion inducing a homeomorphism onto its image.

Firstly, f is an immersion, because for every $p \in M$ there is a j such that $T_p k_j$ has rank m .

Secondly, assume $f(p) = f(q)$ for two points $p, q \in M$. Assume $p \in x_j^{-1}(E^m(1))$. Then we must have that q is also in $x_j^{-1}(E^m(1))$ (since $\psi_j(p) = \psi_j(q)$). But then we have that $k_j(p) = x_j(p)$ is equal to $k_j(q) = x_j(q)$, and hence $p = q$ since x_j is a bijection.

Since M is compact, f is injective (and so $M \rightarrow f(M)$ is bijective) and \mathbf{R}^N Hausdorff, $M \rightarrow f(M)$ is a homeomorphism by theorem . ■

Techniques like this are used to construct imbeddings. However, occasionally it is important to know when imbeddings are not possible, and then these techniques are of no use. For instance, why can't we imbed \mathbf{RP}^2 in \mathbf{R}^3 ? Proving this directly is probably very hard. For such problems algebraic topology is needed.

Chapter 8

Constructions on vector bundles

8.1 Subbundles and restrictions

There are a variety of important constructions we need to address. The first of these have been lying underneath the surface for some time:

Definition 8.1.1 Let

$$\pi: E \rightarrow X$$

be an n -dimensional vector bundle. A k -dimensional *subbundle* of this vector bundle is a subset $E' \subseteq E$ such that around any point there is a bundle chart (h, U) such that

$$h(\pi^{-1}(U) \cap E') = U \times (\mathbf{R}^k \times \{0\}) \subseteq U \times \mathbf{R}^n$$

Note 8.1.2 It makes sense to call such a subset $E' \subseteq E$ a subbundle, since we see that the bundle charts, restricted to E' , define a vector bundle structure on $\pi|_{E'}: E' \rightarrow X$ which is smooth if we start out with a smooth atlas.

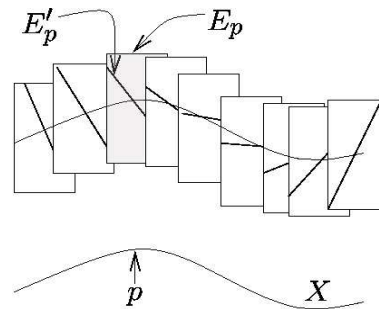

A one-dimensional subbundle in a two-dimensional vector bundle: pick out a one-dimensional linear subspace of every fiber in a continuous (or smooth) manner.

Example 8.1.3 Consider the trivial bundle $S^1 \times \mathbf{C} \rightarrow S^1$. The canonical line bundle $\eta_1 \rightarrow \mathbf{RP}^1 \cong S^1$ can be thought of as the subbundle given by

$$\{(e^{i\theta}, te^{i\theta/2}) \in S^1 \times \mathbf{C} \mid t \in \mathbf{R}\} \subseteq S^1 \times \mathbf{C}.$$

Exercise 8.1.4 Spell out the details of the previous example. Also show that

$$\eta_n = \{([p], \lambda p) \in \mathbf{RP}^n \times \mathbf{R}^{n+1} \mid p \in S^n, \lambda \in \mathbf{R}\} \subseteq \mathbf{RP}^n \times \mathbf{R}^{n+1}$$

is a subbundle of the trivial bundle $\mathbf{RP}^n \times \mathbf{R}^{n+1} \rightarrow \mathbf{RP}^n$.

Definition 8.1.5 Given a bundle $\pi: E \rightarrow X$ and a subspace $A \subseteq X$, the *restriction* to A is the bundle

$$\pi_A: E_A \rightarrow A$$

where $E_A = \pi^{-1}(A)$ and $\pi_A = \pi|_{\pi^{-1}(A)}$.

In the special case where A is a single point $p \in X$, we write $E_p = \pi^{-1}(p)$ (instead of $E_{\{p\}}$). Occasionally it is typographically convenient to write $E|_A$ instead of E_A (especially when the notation is already a bit cluttered).

Note 8.1.6 We see that the restriction is a new vector bundle, and the inclusion

$$\begin{array}{ccc} E_A & \xrightarrow{\subseteq} & E \\ \pi_A \downarrow & & \downarrow \pi \\ A & \xrightarrow{\subseteq} & X \end{array}$$

is a bundle morphism inducing an isomorphism on every fiber.

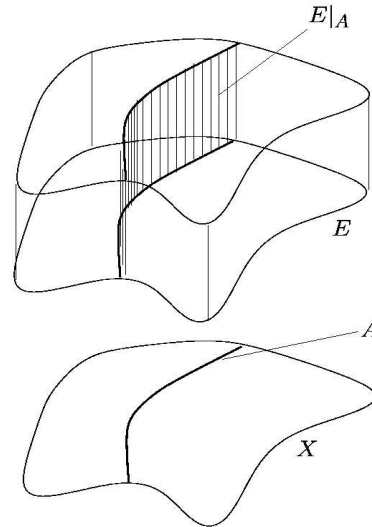

The restriction of a bundle $E \rightarrow X$ to a subset $A \subseteq X$.

Example 8.1.7 Let $N \subseteq M$ be a smooth submanifold. Then we can restrict the tangent bundle on M to N and get

$$(TM)|_N \rightarrow N$$

We see that $TN \subseteq TM|_N$ is a smooth subbundle.

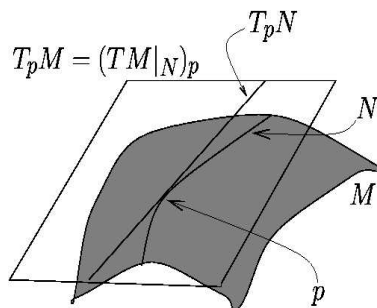

In a submanifold $N \subseteq M$ the tangent bundle of N is naturally a subbundle of the tangent bundle of M restricted to N

Definition 8.1.8 A bundle morphism

$$\begin{array}{ccc} E_1 & \xrightarrow{f} & E_2 \\ \pi_1 \downarrow & & \downarrow \pi_2 \\ X_1 & \longrightarrow & X_2 \end{array}$$

is said to be of *constant rank* r if restricted to each fiber f is a linear map of rank r .

Note that this is a generalization of our concept of constant rank of smooth maps.

Theorem 8.1.9 (*Rank theorem for bundles*) Consider a bundle morphism

$$\begin{array}{ccc} E_1 & \xrightarrow{f} & E_2 \\ & \searrow \pi_1 & \swarrow \pi_2 \\ & X & \end{array}$$

over a space X with constant rank r . Then around any point $p \in X$ there are bundle charts (h, U) and (g, U) such that

$$\begin{array}{ccc} E_1|_U & \xrightarrow{f|_U} & E_2|_U \\ h \downarrow & & \downarrow g \\ U \times \mathbf{R}^m & \xrightarrow{(u, (t_1, \dots, t_m)) \mapsto (u, (t_1, \dots, t_r, 0, \dots, 0))} & U \times \mathbf{R}^n \end{array}$$

commutes.

Furthermore if we are in a smooth situation, these bundle charts may be chosen to be smooth.

Proof: This is a local question, so translating via arbitrary bundle charts we may assume that we are in the trivial situation

$$\begin{array}{ccc} U' \times \mathbf{R}^m & \xrightarrow{f} & U' \times \mathbf{R}^n \\ & \searrow pr_{U'} & \swarrow pr_{U'} \\ & U' & \end{array}$$

with $f(u, v) = (u, (f_u^1(v), \dots, f_u^n(v)))$, and $rk f_u = r$. By a choice of basis on \mathbf{R}^m and \mathbf{R}^n we may assume that f_u is represented by a matrix

$$\begin{bmatrix} A(u) & B(u) \\ C(u) & D(u) \end{bmatrix}$$

with $A(p) \in GL_r(\mathbf{R})$ and $D(p) = C(p)A(p)^{-1}B(p)$ (the last equation follows as the rank $rk f_p$ is r). We change the basis so that this is actually true in the standard basis.

Let $p \in U \subseteq U'$ be the open set $U = \{u \in U' | \det(A(u)) \neq 0\}$. Then again $D(u) = C(u)A(u)^{-1}B(u)$ on U .

Let

$$h: U \times \mathbf{R}^m \rightarrow U \times \mathbf{R}^m, \quad h(u, v) = (u, h_u(v))$$

be the homeomorphism where h_u is given by the matrix

$$\begin{bmatrix} A(u) & B(u) \\ 0 & I \end{bmatrix}$$

Let

$$g: U \times \mathbf{R}^n \rightarrow U \times \mathbf{R}^n, \quad g(u, w) = (u, g_u(w))$$

be the homeomorphism where g_u is given by the matrix

$$\begin{bmatrix} I & 0 \\ -C(u)A(u)^{-1} & I \end{bmatrix}$$

Then $gfh^{-1}(u, v) = (u, (gfh^{-1})_u(v))$ where $(gfh^{-1})_u$ is given by the matrix

$$\begin{aligned} & \begin{bmatrix} I & 0 \\ -C(u)A(u)^{-1} & I \end{bmatrix} \begin{bmatrix} A(u) & B(u) \\ C(u) & D(u) \end{bmatrix} \begin{bmatrix} A(u) & B(u) \\ 0 & I \end{bmatrix}^{-1} \\ = & \begin{bmatrix} I & 0 \\ -C(u)A(u)^{-1} & I \end{bmatrix} \begin{bmatrix} A(u) & B(u) \\ C(u) & D(u) \end{bmatrix} \begin{bmatrix} A(u)^{-1} & -A(u)^{-1}B(u) \\ 0 & I \end{bmatrix} \\ = & \begin{bmatrix} I & 0 \\ -C(u)A(u)^{-1} & I \end{bmatrix} \begin{bmatrix} I & 0 \\ C(u)A(u)^{-1} & 0 \end{bmatrix} \\ = & \begin{bmatrix} I & 0 \\ 0 & 0 \end{bmatrix} \end{aligned}$$

as claimed (the right hand lower zero in the answer is really a $0 = -C(u)A(u)^{-1}B(u) + D(u)$). ■

Recall that if $f: V \rightarrow W$ is a linear map of vector spaces, then the *kernel* (or *null space*) is the subspace

$$\ker\{f\} = \{v \in V | f(v) = 0\} \subseteq V$$

and the *image* (or *range*) is the subspace

$$\text{im}\{f\} = \{w \in W | \text{there is a } v \in V \text{ such that } w = f(v)\}$$

Corollary 8.1.10 *If*

$$\begin{array}{ccc} E_1 & \xrightarrow{f} & E_2 \\ & \searrow \pi_1 & \swarrow \pi_2 \\ & & X \end{array}$$

is a bundle morphism of constant rank, then the kernel

$$\bigcup_{p \in X} \ker\{f_p\} \subseteq E_1$$

and image

$$\bigcup_{p \in X} \operatorname{im}\{f_p\} \subseteq E_2$$

are subbundles.

Exercise 8.1.11 Let $\pi: E \rightarrow X$ be a vector bundle over a connected space X . Assume given a bundle morphism

$$\begin{array}{ccc} E & \xrightarrow{f} & E \\ & \searrow \pi & \swarrow \pi \\ & X & \end{array}$$

with $f \circ f = f$. Prove that f has constant rank.

Exercise 8.1.12 Let $\pi: E \rightarrow X$ be a vector bundle over a connected space X . Assume given a bundle morphism

$$\begin{array}{ccc} E & \xrightarrow{f} & E \\ & \searrow \pi & \swarrow \pi \\ & X & \end{array}$$

with $f \circ f = id_E$. Prove that the space of fixed points

$$E^{\{f\}} = \{e \in E \mid f(e) = e\}$$

is a subbundle of E .

8.2 The induced bundles

Definition 8.2.1 Assume given a bundle $\pi: E \rightarrow Y$ and a continuous map $f: X \rightarrow Y$. Let the *fiber product* of f and π be the space

$$f^*E = X \times_Y E = \{(x, e) \in X \times E \mid f(x) = \pi(e)\}$$

(topologized as a subspace of $X \times E$), and let *the induced bundle* be the projection

$$f^*\pi: f^*E \rightarrow X, \quad (x, e) \mapsto x$$

Note that the fiber over $x \in X$ may be identified with the fiber over $f(x) \in Y$.

Lemma 8.2.2 *If $\pi: E \rightarrow Y$ is a vector bundle and $f: X \rightarrow Y$ a continuous map, then*

$$f^*\pi: f^*E \rightarrow X$$

*is a vector bundle and the projection $f^*E \rightarrow E$ defines a bundle morphism*

$$\begin{array}{ccc} f^*E & \longrightarrow & E \\ f^*\pi \downarrow & & \pi \downarrow \\ X & \xrightarrow{f} & Y \end{array}$$

inducing an isomorphism on fibers. If the input is smooth the output is smooth too.

Proof: Let $p \in X$ and let (h, V) be a bundle chart

$$h: \pi^{-1}(V) \rightarrow V \times \mathbf{R}^k$$

such that $f(p) \in V$. Then $U = f^{-1}(V)$ is an open neighborhood of p . Note that

$$\begin{aligned} (f^*\pi)^{-1}(U) &= \{(u, e) \in X \times E \mid f(u) = \pi(e) \in V\} \\ &= \{(u, e) \in U \times \pi^{-1}(V) \mid f(u) = \pi(e)\} \\ &= U \times_V \pi^{-1}(V) \end{aligned}$$

and

$$U \times_V (V \times \mathbf{R}^k) \cong U \times \mathbf{R}^k$$

and we define

$$\begin{aligned} f^*h: (f^*\pi)^{-1}(U) = U \times_V \pi^{-1}(V) &\rightarrow U \times_V (V \times \mathbf{R}^k) \cong U \times \mathbf{R}^k \\ (u, e) &\mapsto (u, h(e)) \leftrightarrow (u, h_{\pi(e)}e) \end{aligned}$$

Since h is a homeomorphism f^*h is a homeomorphism (smooth if h is), and since $h_{\pi(e)}e$ is an isomorphism (f^*h) is an isomorphism on each fiber. The rest of the lemma now follows automatically. ■

Theorem 8.2.3 *Let*

$$\begin{array}{ccc} E' & \xrightarrow{\tilde{f}} & E \\ \pi' \downarrow & & \pi \downarrow \\ X' & \xrightarrow{f} & X \end{array}$$

be a bundle morphism.

Then there is a factorization

$$\begin{array}{ccccc} E' & \longrightarrow & f^*E & \longrightarrow & E \\ \pi' \downarrow & & f^*\pi \downarrow & & \pi \downarrow \\ X' & \xlongequal{\quad} & X' & \xrightarrow{f} & X \end{array}$$

Proof: Let

$$\begin{aligned} E' &\rightarrow X' \times_X E = f^*E \\ e &\mapsto (\pi'(e), \tilde{f}(e)) \end{aligned}$$

This is well defined since $f(\pi'(e)) = \pi(\tilde{f}(e))$. It is linear on the fibers since the composition

$$(\pi')^{-1}(p) \rightarrow (f^*\pi)^{-1}(p) \cong \pi^{-1}(f(p))$$

is nothing but \tilde{f}_p . ■

Exercise 8.2.4 Let $i: A \subseteq X$ be an injective map and $\pi: E \rightarrow X$ a vector bundle. Prove that the induced and the restricted bundles are isomorphic.

Exercise 8.2.5 Show the following statement: if

$$\begin{array}{ccccc} E' & \xrightarrow{h} & \tilde{E} & \xrightarrow{g} & E \\ \pi' \downarrow & & \tilde{\pi} \downarrow & & \pi \downarrow \\ X' & \xlongequal{\quad} & X' & \xrightarrow{f} & X \end{array}$$

is a factorization of (f, \tilde{f}) , then there is a unique bundle map

$$\begin{array}{ccc} \tilde{E} & \xrightarrow{\quad} & f^*E \\ & \searrow & \swarrow \\ & X & \end{array}$$

such that

$$\begin{array}{ccccc} E' & \xrightarrow{\quad} & \tilde{E} & & \\ & \searrow & \downarrow & \searrow & \\ & & f^*E & \xrightarrow{\quad} & E \end{array}$$

commutes.

As a matter of fact, you could characterize the induced bundle by this property.

Exercise 8.2.6 Show that if $E \rightarrow X$ is a trivial vector bundle and $f: Y \rightarrow X$ a map, then $f^*E \rightarrow Y$ is trivial.

Exercise 8.2.7 Let $E \rightarrow Z$ be a vector bundle and let

$$X \xrightarrow{f} Y \xrightarrow{g} Z$$

be maps. Show that $((gf)^*E \rightarrow X) \cong (f^*(g^*E) \rightarrow X)$.

Exercise 8.2.8 Let $\pi: E \rightarrow X$ be a vector bundle, $\sigma_0: X \rightarrow E$ the zero section, and $\pi_0: E \setminus \sigma_0(X) \rightarrow X$ be the restriction of π . Construct a nonvanishing section on $\pi_0^*E \rightarrow X$.

8.3 Whitney sum of bundles

Natural constructions you can perform on vector spaces, pass to constructions on vector bundles by applying the constructions on each fiber. As an example we here consider the sum. You should check that you believe the constructions, since we plan to be sketchier on future examples.

If V_1 and V_2 are vector spaces, then $V_1 \oplus V_2 = V_1 \times V_2$ is the vector space of pairs (v_1, v_2) with $v_j \in V_j$. If $f_j: V_j \rightarrow W_j$ is a linear map $j = 1, 2$, then

$$f_1 \oplus f_2: V_1 \oplus V_2 \rightarrow W_1 \oplus W_2$$

is the linear map which sends (v_1, v_2) to $(f_1(v_1), f_2(v_2))$.

Definition 8.3.1 Let $(\pi_1: E_1 \rightarrow X, \mathcal{A}_1)$ and $(\pi_2: E_2 \rightarrow X, \mathcal{A}_2)$ be vector bundles over a common space X . Let

$$E_1 \oplus E_2 = \coprod_{x \in X} \pi_1^{-1}(x) \oplus \pi_2^{-1}(x)$$

and let $\pi_1 \oplus \pi_2: E_1 \oplus E_2 \rightarrow X$ send all points in the x 'th summand to $x \in X$. If $(h_1, U_1) \in \mathcal{A}_1$ and $(h_2, U_2) \in \mathcal{A}_2$ then

$$h_1 \oplus h_2: (\pi_1 \oplus \pi_2)^{-1}(U_1 \cap U_2) \rightarrow (U_1 \cap U_2) \times (\mathbf{R}^{n_1} \oplus \mathbf{R}^{n_2})$$

is $h_1 \oplus h_2$ on each fiber (i.e. over the point $p \in X$ it is $(h_1)_p \oplus (h_2)_p: \pi_1^{-1}(p) \oplus \pi_2^{-1}(p) \rightarrow \mathbf{R}^{n_1} \oplus \mathbf{R}^{n_2}$).

This defines a pre-vector bundle, and the associated vector bundle is called the *Whitney sum* of the two vector bundles.

If

$$\begin{array}{ccc} E_j & \xrightarrow{f_j} & E'_j \\ & \searrow \pi_j & \swarrow \pi'_j \\ & & X \end{array}$$

are bundle morphisms over X , then

$$\begin{array}{ccc} E_1 \oplus E_2 & \xrightarrow{f_1 \oplus f_2} & E'_1 \oplus E'_2 \\ & \searrow \pi_1 \oplus \pi_2 & \swarrow \pi'_1 \oplus \pi'_2 \\ & & X \end{array}$$

is a bundle morphism defined as $f_1 \oplus f_2$ on each fiber.

Exercise 8.3.2 Check that if all bundles and morphisms are smooth, then the Whitney sum is a smooth bundle too, and that $f_1 \oplus f_2$ is a smooth bundle morphism over X .

Note 8.3.3 Although $\oplus = \times$ for vector spaces, we must not mix them for vector bundles, since \times is reserved for another construction: the product of two bundles $E_1 \times E_2 \rightarrow X_1 \times X_2$.

Exercise 8.3.4 Let

$$\epsilon = \{(p, \lambda p) \in \mathbf{R}^{n+1} \times \mathbf{R}^{n+1} \mid |p| = 1, \lambda \in \mathbf{R}\}$$

Show that the projection down to S^n defines a trivial bundle.

Definition 8.3.5 A bundle $E \rightarrow X$ is called *stably trivial* if there is a trivial bundle $\epsilon \rightarrow X$ such that $E \oplus \epsilon \rightarrow X$ is trivial.

Exercise 8.3.6 Show that the tangent bundle of the sphere $TS^n \rightarrow S^n$ is stably trivial.

Exercise 8.3.7 Show that the sum of two trivial bundles is trivial. Also that the sum of two stably trivial bundles is stably trivial.

Exercise 8.3.8 Given three bundles $\pi_i: E_i \rightarrow X, i = 1, 2, 3$. Show that the set of pairs (f_1, f_2) of bundle morphisms

$$\begin{array}{ccc} E_i & \xrightarrow{f_i} & E_3 \\ & \searrow \pi_i & \swarrow \pi_3 \\ & X & \end{array}$$

($i = 1, 2$) is in one-to-one correspondence with the set of bundle morphisms

$$\begin{array}{ccc} E_1 \oplus E_2 & \xrightarrow{\quad} & E_3 \\ & \searrow \pi_1 \oplus \pi_2 & \swarrow \pi_3 \\ & X & \end{array}$$

8.4 More general linear algebra on bundles

There are many constructions on vector spaces that pass on to bundles. We list a few. The examples 1-4 and 8-9 will be used in the text, and the others are listed for reference, and for use in exercises.

8.4.1 Constructions on vector spaces

1. *The (Whitney) sum.* If V_1 and V_2 are vector spaces, then $V_1 \oplus V_2$ is the vector space of pairs (v_1, v_2) with $v_j \in V_j$. If $f_j: V_j \rightarrow W_j$ is a linear map $j = 1, 2$, then

$$f_1 \oplus f_2: V_1 \oplus V_2 \rightarrow W_1 \oplus W_2$$

is the linear map which sends (v_1, v_2) to $(f_1(v_1), f_2(v_2))$.

2. *The quotient.* If $W \subseteq V$ is a linear subspace we may define the quotient V/W as the set of equivalence classes V/\sim under the equivalence relation that $v \sim v'$ if there is a $w \in W$ such that $v = v' + w$. The equivalence class containing $v \in V$ is written \bar{v} . We note that V/W is a vector space with

$$a\bar{v} + b\bar{v}' = \overline{av + bv'}$$

If $f: V \rightarrow V'$ is a linear map with $f(W) \subseteq W'$ then f defines a linear map

$$\bar{f}: V/W \rightarrow V'/W'$$

via the formula $\bar{f}(\bar{v}) = \overline{f(v)}$ (check that this makes sense).

3. *The hom-space.* Let V and W be vector spaces, and let

$$\text{Hom}(V, W)$$

be the set of linear maps $f: V \rightarrow W$. This is a vector space via the formula $(af + bg)(v) = af(v) + bg(v)$. Note that

$$\text{Hom}(\mathbf{R}^m, \mathbf{R}^n) \cong M_{n \times m}(\mathbf{R})$$

Also, if $R: V \rightarrow V'$ and $S: W \rightarrow W'$ are linear maps, then we get a linear map

$$\text{Hom}(V', W) \xrightarrow{\text{Hom}(R, S)} \text{Hom}(V, W')$$

by sending $f: V' \rightarrow W$ to

$$V \xrightarrow{R} V' \xrightarrow{f} W \xrightarrow{S} W'$$

(note that the direction of R is turned around!).

4. *The dual space* This is a special case of the example above: if V is a vector space, then the dual space is the vector space

$$V^* = \text{Hom}(V, \mathbf{R})$$

5. *The tensor product.* Let V and W be vector spaces. Consider the set of bilinear maps from $V \times W$ to some other vector space V' . The *tensor product*

$$V \otimes W$$

is the vector space codifying this situation in the sense that giving a bilinear map $V \times W \rightarrow V'$ is the same as giving a linear map $V \otimes W \rightarrow V'$. With this motivation it is possible to write down explicitly what $V \otimes W$ is: as a set it is the set of all

finite linear combinations of symbols $v \otimes w$ where $v \in V$ and $w \in W$ subject to the relations

$$\begin{aligned} a(v \otimes w) &= (av) \otimes w = v \otimes (aw) \\ (v_1 + v_2) \otimes w &= v_1 \otimes w + v_2 \otimes w \\ v \otimes (w_1 + w_2) &= v \otimes w_1 + v \otimes w_2 \end{aligned}$$

where $a \in \mathbf{R}$, $v, v_1, v_2 \in V$ and $w, w_1, w_2 \in W$. This is a vector space in the obvious manner, and given linear maps $f: V \rightarrow V'$ and $g: W \rightarrow W'$ we get a linear map

$$f \otimes g: V \otimes W \rightarrow V' \otimes W'$$

by sending $\sum_{i=1}^k v_i \otimes w_i$ to $\sum_{i=1}^k f(v_i) \otimes g(w_i)$ (check that this makes sense!).

Note that

$$\mathbf{R}^m \otimes \mathbf{R}^n \cong \mathbf{R}^{mn}$$

and that there are isomorphisms

$$\text{Hom}(V \otimes W, V') \cong \{\text{bilinear maps } V \times W \rightarrow V'\}$$

The bilinear map associated to a linear map $f: V \otimes W \rightarrow V'$ sends $(v, w) \in V \times W$ to $f(v \otimes w)$. The linear map associated to a bilinear map $g: V \times W \rightarrow V'$ sends $\sum v_i \otimes w_i \in V \otimes W$ to $\sum g(v_i, w_i)$.

6. *The exterior power.* Let V be a vector space. The k th exterior power $\Lambda^k V$ is defined as the quotient of the k -fold tensor product $V \otimes \cdots \otimes V$ by the subspace generated by the elements $v_1 \otimes v_2 \otimes \cdots \otimes v_k$ where $v_i = v_j$ for some $i \neq j$. The image of $v_1 \otimes v_2 \otimes \cdots \otimes v_k$ in $\Lambda^k V$ is written $v_1 \wedge v_2 \wedge \cdots \wedge v_k$. Note that it follows that $v_1 \wedge v_2 = -v_2 \wedge v_1$ since

$$0 = (v_1 + v_2) \wedge (v_1 + v_2) = v_1 \wedge v_1 + v_1 \wedge v_2 + v_2 \wedge v_1 + v_2 \wedge v_2 = v_1 \wedge v_2 + v_2 \wedge v_1$$

and similarly for more \wedge -factors: swapping two entries changes sign.

Note that the dimension of $\Lambda^k \mathbf{R}^n$ is $\binom{n}{k}$. There is a particularly nice isomorphism $\Lambda^n \mathbf{R}^n \rightarrow \mathbf{R}$ given by the determinant function.

7. *The symmetric power.* Let V be a vector space. The k th symmetric power $S^k V$ is defined as the quotient of the k -fold tensor product $V \otimes \cdots \otimes V$ by the subspace generated by the elements $v_1 \otimes v_2 \otimes \cdots \otimes v_i \otimes \cdots \otimes v_j \otimes \cdots \otimes v_k - v_1 \otimes v_2 \otimes \cdots \otimes v_j \otimes \cdots \otimes v_i \otimes \cdots \otimes v_k$.
8. *Alternating forms.* The space of alternating forms $\text{Alt}^k(V)$ on a vector space V is defined to be $(\Lambda^k V)^*$. That is $\text{Alt}^k(V)$ consists of the multilinear maps

$$V \times \cdots \times V \rightarrow \mathbf{R}$$

in k V -variables which are zero on inputs with repeated coordinates.

The alternating forms on the tangent space is the natural home of the symbols like $dx dy dz$ you'll find in elementary multivariable analysis.

9. *Symmetric bilinear forms.* Let V be a vector space. The space of $SB(V)$ symmetric bilinear forms is the space of bilinear maps $f: V \times V \rightarrow R$ such that $f(v, w) = f(w, v)$. In other words, the space of symmetric bilinear forms is $SB(V) = (S^2V)^*$.

8.4.2 Constructions on vector bundles

When translating these constructions to vector bundles, it is important not only to bear in mind what they do on each individual vector space but also what they do on linear maps. Note that some of the examples “turn the arrows around”. The Hom -space in 8.4.13 is a particular example of this: it “turns the arrows around” in the first variable, but not in the second.

Instead of giving the general procedure for translating such constructions to bundles in general, we do it on the Hom -space which exhibit all the potential difficult points.

Example 8.4.3 Let $(\pi: E \rightarrow X, \mathcal{B})$ and $(\pi': E' \rightarrow X, \mathcal{B}')$ be vector bundles of dimension m and n . We define a pre-vector bundle

$$Hom(E, E') = \coprod_{p \in X} Hom(E_p, E'_p) \rightarrow X$$

of dimension mn as follows. The projection sends the p th summand to p , and given bundle charts $(h, U) \in \mathcal{B}$ and $(h', U') \in \mathcal{B}'$ we define a bundle chart $(Hom(h^{-1}, h'), U \cap U')$. On the fiber above $p \in X$,

$$Hom(h^{-1}, h')_p: Hom(E_p, E'_p) \rightarrow Hom(\mathbf{R}^m, \mathbf{R}^n) \cong \mathbf{R}^{mn}$$

is given by sending $f: E_p \rightarrow E'_p$ to

$$\mathbf{R}^m \xrightarrow{h_p^{-1}} E_p \xrightarrow{f} E'_p \xrightarrow{h'_p} \mathbf{R}^n$$

Exercise 8.4.4 Let $E \rightarrow X$ and $E' \rightarrow X$ be vector bundles. Show that there is a one-to-one correspondence between bundle morphisms

$$\begin{array}{ccc} E & \xrightarrow{f} & E' \\ & \searrow & \swarrow \\ & X & \end{array}$$

and sections of $Hom(E, E') \rightarrow X$.

Exercise 8.4.5 Convince yourself that the construction of $Hom(E, E') \rightarrow X$ outlined above really gives a vector bundle, and that if

$$\begin{array}{ccc} E & \xrightarrow{f} & E_1 \\ & \searrow & \swarrow \\ & X & \end{array}, \text{ and } \begin{array}{ccc} E' & \xrightarrow{f'} & E'_1 \\ & \searrow & \swarrow \\ & X & \end{array}$$

are bundle morphisms, we get another

$$\begin{array}{ccc} \text{Hom}(E_1, E') & \xrightarrow{\text{Hom}(f, f')} & \text{Hom}(E, E'_1) \\ & \searrow & \swarrow \\ & X & \end{array}$$

Exercise 8.4.6 Write out the definition of the *quotient bundle*, and show that if

$$\begin{array}{ccc} E & \xrightarrow{f} & E' \\ & \searrow & \swarrow \\ & X & \end{array}$$

is a bundle map, $F \subseteq E$ and $F' \subseteq E'$ are subbundles such that $\text{im}\{f|_F\} \subseteq F'$, then we get a bundle morphism

$$\begin{array}{ccc} E/F & \xrightarrow{\bar{f}} & E'/F' \\ & \searrow & \swarrow \\ & X & \end{array}$$

Exercise 8.4.7 Write out the definition of the bundle of alternating k -forms, and if you are still not bored stiff, do some more examples. If you are really industrious, find out on what level of generality these ideas really work, and prove it there.

Exercise 8.4.8 Let $L \rightarrow M$ be a line bundle (one-dimensional vector bundle). Show that $L \otimes L \rightarrow M$ is trivial.

8.5 Riemannian structures

In differential geometry one works with more highly structured manifolds than in differential topology. In particular, all manifolds should come equipped with metrics on the tangent spaces which vary smoothly from point to point. This is what is called a Riemannian manifold, and is crucial to many applications (for instance general relativity is all about Riemannian manifolds). In this section we will show that all smooth manifolds have a structure of a Riemannian manifold. However, the reader should notice that there is a huge difference between merely saying that a given manifold has *some* Riemannian structure, and actually working with manifolds with a *chosen* Riemannian structure.

Definition 8.5.1 Let $\pi: E \rightarrow X$ be a vector bundle, and let $SB(\pi): SB(E) \rightarrow X$ be the bundle whose fiber above $p \in X$ is given by the symmetric bilinear forms $E_p \times E_p \rightarrow \mathbf{R}$ 8.4.19 (that is, $SB(E) = (S^2 E)^* \rightarrow X$ in the language of 8.4.14 and 8.4.17). A *Riemannian*

metric is a section $g: X \rightarrow SB(E)$, such that for every $p \in X$ $g_p: E_p \times E_p \rightarrow \mathbf{R}$ is (symmetric, bilinear and) positive definite. The Riemannian metric is smooth if $E \rightarrow X$ and the section g are smooth.

Definition 8.5.2 A *Riemannian manifold* is a smooth manifold with a smooth Riemannian metric on the tangent bundle.

Theorem 8.5.3 Let M be a differentiable manifold and let $E \rightarrow M$ be an n -dimensional smooth bundle with bundle atlas \mathcal{B} . Then there is a Riemannian structure on $E \rightarrow M$

Proof: Choose a good atlas $\mathcal{A} = \{(x_i, V_i)\}_{i \in \mathbf{N}}$ subordinate to $\{U | (h, U) \in \mathcal{B}\}$ and a smooth partition of unity $\{\phi_i: M \rightarrow \mathbf{R}\}$ with $\text{supp}(\phi_i) \subset V_i$ as given by in the proof of theorem 7.4.1.

Since for any of the V_i 's, there is a bundle chart (h, U) in \mathcal{B} such that $V_i \subseteq U$, the bundle restricted to any V_i is trivial. Hence we may choose a Riemannian structure, i.e. a section

$$\sigma_i: V_i \rightarrow SB(E)|_{V_i}$$

such that σ_i is (bilinear, symmetric and) positive definite on every fiber. For instance we may let $\sigma_i(p) \in SB(E_p)$ be the positive definite symmetric bilinear map

$$E_p \times E_p \xrightarrow{h_p \times h_p} \mathbf{R}^n \times \mathbf{R}^n \xrightarrow{(v,w) \mapsto v \cdot w = v^T w} \mathbf{R}$$

Let $g_i: M \rightarrow SB(E)$ be defined by

$$g_i(p) = \begin{cases} \phi_i(p)\sigma_i(p) & \text{if } p \in V_i \\ 0 & \text{otherwise} \end{cases}$$

and let $g: M \rightarrow SB(E)$ be given as the sum $g(p) = \sum_i g_i(p)$. The property “positive definite” is *convex*, i.e. if σ_1 and σ_2 are two positive definite forms on a vector space and $t \in [0, 1]$, then $t\sigma_1 + (1-t)\sigma_2$ is also positive definite (since $t\sigma_1(v, v) + (1-t)\sigma_2(v, v)$ must obviously be nonnegative, and can be zero only if $\sigma_1(v, v) = \sigma_2(v, v) = 0$). By induction we get that $g(p)$ is positive definite since all the $\sigma_i(p)$'s were positive definite.

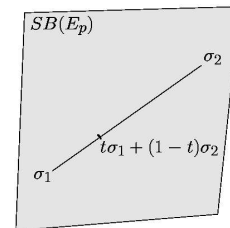

In the space of symmetric bilinear forms, all the points on the straight line between two positive definite forms are positive definite.

■

Corollary 8.5.4 All smooth manifolds possess Riemannian metrics.

8.6 Normal bundles

Definition 8.6.1 Given a bundle $\pi: E \rightarrow X$ with a chosen Riemannian metric g and a subbundle $F \subseteq E$, then we define the *normal bundle* with respect to g of $F \subseteq E$ to be the subset

$$F^\perp = \coprod_{p \in X} F_p^\perp$$

given by taking the orthogonal complement of $F_p \in E_p$ (relative to the metric $g(p)$).

Lemma 8.6.2 *Given a bundle $\pi: E \rightarrow X$ with a Riemannian metric g and a subbundle $F \subseteq E$, then*

1. *the normal bundle $F^\perp \subseteq E$ is a subbundle*
2. *the composite*

$$F^\perp \subseteq E \rightarrow E/F$$

is an isomorphism of bundles over X .

Proof: Choose a bundle chart (h, U) such that

$$h(F|_U) = U \times (\mathbf{R}^k \times \{0\}) \subseteq U \times \mathbf{R}^n$$

Let $v_j(p) = h^{-1}(p, e_j) \in E_p$ for $p \in U$. Then $(v_1(p), \dots, v_n(p))$ is a basis for E_p whereas $(v_1(p), \dots, v_k(p))$ is a basis for F_p . We can then perform the Gram-Schmidt process with respect to the metric $g(p)$ to transform these bases to orthogonal bases $(v'_1(p), \dots, v'_n(p))$ for E_p , $(v'_1(p), \dots, v'_k(p))$ for F_p and $(v'_{k+1}(p), \dots, v'_n(p))$ for F_p^\perp .

We can hence define a new bundle chart (h', U) given by

$$h': E|_U \rightarrow U \times \mathbf{R}^n$$

$$\sum_{i=1}^n a_i v'_i(p) \mapsto (p, (a_1, \dots, a_n))$$

(it is a bundle chart since the metric varies continuously with p , and so the basis change from $\{v_i\}$ to $\{v'_i\}$ is not only an isomorphism on each fiber, but a homeomorphism) which gives $F^\perp|_U$ as $U \times (\{0\} \times \mathbf{R}^{n-k})$.

For the second claim, observe that the dimension of F^\perp equal to the dimension of E/F , and so the claim follows if the map $F^\perp \subseteq E \rightarrow E/F$ is injective on every fiber, but this is true since $F_p \cap F_p^\perp = \{0\}$. ■

Note 8.6.3 Note that the bundle chart h' produced in the lemma above is orthogonal on every fiber (i.e. $g(x)(e, e') = (h'(e)) \cdot (h'(e'))$). This means that all the transition functions between maps produced in this fashion would be orthogonal, i.e. members of the orthogonal subgroup $O(n) \subseteq \text{GL}_n(\mathbf{R})$. In conclusion:

Proposition 8.6.4 Every (smooth) manifold possesses an atlas whose transition functions are orthogonal.

Exercise 8.6.5 Consider a bundle $E \rightarrow X$ with a Riemannian metric and a subbundle $F \subseteq E$. Show that the morphism

$$\begin{array}{ccc} F \oplus F^\perp & \xrightarrow{\quad} & E \\ & \searrow & \swarrow \\ & X & \end{array}$$

induced by the inclusions is an isomorphism.

Definition 8.6.6 Let $N \subseteq M$ be a smooth submanifold. The *normal bundle* $\perp N \rightarrow N$ is defined as the quotient bundle $(TM|_N)/TN \rightarrow N$ (see exercise 8.4.6).

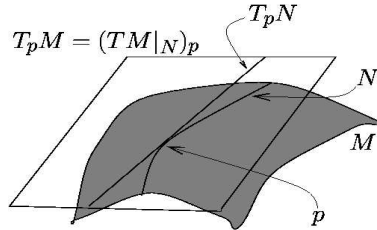

In a submanifold $N \subseteq M$ the tangent bundle of N is naturally a subbundle of the tangent bundle of M restricted to N , and the normal bundle is the quotient on each fiber, or isomorphically in each fiber: the normal space

More generally, if $f: N \rightarrow M$ is an imbedding, we define the normal bundle $\perp^f N \rightarrow N$ to be the bundle $(f^*TM)/TN \rightarrow N$.

Note 8.6.7 With respect to some Riemannian structure on M , we note that the normal bundle $\perp N \rightarrow N$ of $N \subseteq M$ is isomorphic to $(TN)^\perp \rightarrow N$.

Exercise 8.6.8 Let $M \subseteq \mathbf{R}^n$ be a smooth submanifold. Prove that $\perp M \oplus TM \rightarrow M$ is trivial.

Exercise 8.6.9 Consider S^n as a smooth submanifold of \mathbf{R}^{n+1} in the usual way. Prove that the normal bundle is trivial.

Exercise 8.6.10 Let M be a smooth manifold, and consider M as a submanifold by imbedding it as the diagonal in $M \times M$ (i.e. as the set $\{(p, p) \in M \times M\}$: show that it is a smooth submanifold). Prove that the normal bundle $\perp M \rightarrow M$ is isomorphic to $TM \rightarrow M$.

8.7 Transversality

In theorem 6.4.3 we learned about regular values, and inverse images of these. Often interesting submanifolds naturally occur not as inverse images of points, but as inverse images of submanifolds. How is one to guarantee that the inverse image of a submanifold is a submanifold? The relevant term is *transversality*.

Definition 8.7.1 let $f: N \rightarrow M$ be a smooth map and $L \subset M$ a smooth submanifold. We say that f is *transverse* to $L \subset M$ if for all $p \in f^{-1}(L)$ the induced map

$$T_p N \xrightarrow{T_p f} T_{f(p)} M \longrightarrow T_{f(p)} M / T_{f(p)} L$$

is surjective.

Note 8.7.2 If $L = \{q\}$ in the definition above, we recover the definition of a regular point.

Another common way of expressing transversality is to say that for all $p \in f^{-1}(L)$ the image of $T_p f$ and $T_{f(p)} L$ together span $T_{f(p)} M$: this is easier to picture

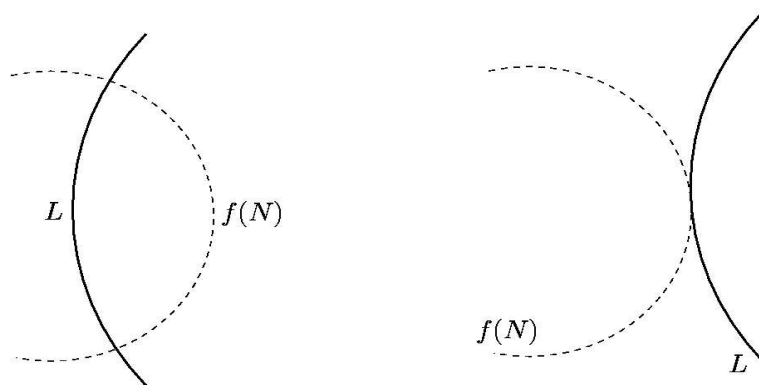

The picture to the left is a typical transverse situation, whereas the situation to the right definitely can't be transverse since $\text{im}\{T_p f\}$ and $T_{f(p)} L$ only spans a one-dimensional space. Beware that pictures like this can be misleading, since the situation to the left fails to be transverse if f slows down at the intersection so that $\text{im}\{T_p f\} = 0$.

Note that the definition only talks about points in $f^{-1}(L)$, and so if $f(N) \cap L = \emptyset$ the condition is vacuous and f and L are transverse.

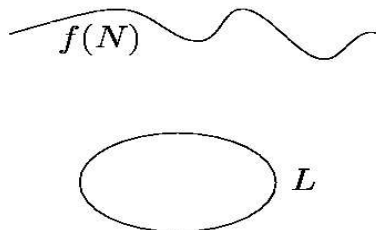

A map is always transverse to a submanifold its image does not intersect.

Furthermore if f is a submersion (i.e. $T_p f$ is always surjective), then f is transverse to all submanifolds.

Theorem 8.7.3 *Assume $f: N \rightarrow M$ is transverse to a k -codimensional submanifold $L \subseteq M$ and that $f(N) \cap L \neq \emptyset$. Then $f^{-1}(L) \subseteq N$ is a k -codimensional manifold and there is an isomorphism*

$$\begin{array}{ccc} \perp f^{-1}(L) & \xrightarrow{\cong} & f^*(\perp L) \\ & \searrow & \swarrow \\ & f^{-1}(L) & \end{array}$$

Proof: Let $q \in L$ and $p \in f^{-1}(q)$, and choose a chart (y, V) around q such that $y(q) = 0$ and

$$y(L \cap V) = y(V) \cap (\mathbf{R}^{n-k} \times \{0\})$$

Let $\pi: \mathbf{R}^n \rightarrow \mathbf{R}^k$ be the projection $\pi(t_1, \dots, t_n) = (t_{n-k+1}, \dots, t_n)$. Consider the diagram

$$\begin{array}{ccccc} T_p N & \xrightarrow{T_p f} & T_q M & \longrightarrow & T_q M / T_p L \\ & & T_q y \downarrow \cong & & \downarrow \cong \\ & & T_0 \mathbf{R}^n & \longrightarrow & T_0 \mathbf{R}^n / T_0 \mathbf{R}^{n-k} \xrightarrow{\cong} T_0 \mathbf{R}^k \end{array}$$

The top horizontal composition is surjective by the transversality hypothesis, and the lower horizontal composite is defined as $T_0 \pi$. Then we get that p is a regular point to the composite

$$U = f^{-1}(V) \xrightarrow{f|_U} V \xrightarrow{y} y(V) \xrightarrow{\pi|_{y(V)}} \mathbf{R}^k$$

and varying p in $f^{-1}(q)$ we get that $0 \in \mathbf{R}^k$ is a regular value. Hence

$$(\pi y f|_U)^{-1}(0) = f^{-1} y^{-1} \pi^{-1}(0) \cap U = f^{-1}(L) \cap U$$

is a submanifold of codimension k in U , and therefore $f^{-1}(L) \subseteq N$ is a k -codimensional submanifold.

Consider the diagram

$$\begin{array}{ccc} T(f^{-1}(L)) & \longrightarrow & TL \\ \downarrow & & \downarrow \\ TN|_{f^{-1}(L)} & \longrightarrow & TM|_L \\ \downarrow & & \downarrow \\ (TN|_{f^{-1}(L)})/T(f^{-1}(L)) = \perp f^{-1}(L) & \longrightarrow & (TM|_L)/TL = \perp L \end{array}$$

Transversality gives that the map from $TN|_{f^{-1}(L)}$ to $(TM|_L)/TL$ is surjective on every fiber, and so – for dimensional reasons – $\perp f^{-1}(L) \rightarrow \perp L$ is an isomorphism on every fiber. This then implies that $\perp f^{-1}(L) \rightarrow f^*(\perp L)$ must be an isomorphism by lemma 5.3.12. ■

Corollary 8.7.4 Consider a smooth map $f: N \rightarrow M$ and a regular value $q \in M$. Then the normal bundle $\perp f^{-1}(q) \rightarrow f^{-1}(q)$ is trivial.

Note 8.7.5 In particular, this gives yet another proof of the fact that the normal bundle of $S^n \subseteq \mathbf{R}^{n+1}$ is trivial. Also it shows that the normal bundle of $O(n) \subseteq M_n(\mathbf{R})$ is trivial, and all the other manifolds we constructed in chapter 5 as the inverse image of regular values. A side effect of this is that the tangent bundles over the manifolds that are inverse images of regular values of maps between euclidean spaces are stably trivial.

Exercise 8.7.6 Consider two smooth maps

$$M \xrightarrow{f} N \xleftarrow{g} L$$

Define the *fiber product*

$$M \times_N L = \{(p, q) \in M \times L \mid f(p) = g(q)\}$$

(topologized as a subspace of the product $M \times L$). Assume that for all $(p, q) \in M \times_N L$ the subspaces spanned by the images of $T_p M$ and $T_q L$ equals all of $T_{f(p)} N$. Show that the fiber product $M \times_N L$ may be given a smooth structure.

8.8 Orientations

The space of alternating forms $Alt^k(V)$ on a vector space V is defined to be $(\Lambda^k V)^* = Hom(\Lambda^k V, \mathbf{R})$, or alternatively, $Alt^k(V)$ consists of the multilinear maps

$$V \times \cdots \times V \rightarrow \mathbf{R}$$

in k V -variables which are zero on inputs with repeated coordinates.

In particular, if $V = \mathbf{R}^k$ we have the *determinant function*

$$det \in Alt^k(\mathbf{R}^k)$$

given by sending $v_1 \wedge \cdots \wedge v_k$ to the determinant of the $k \times k$ -matrix $[v_1 \dots v_k]$ you get by considering v_i as the i th column.

In fact, $det: \bigwedge^k \mathbf{R}^k \rightarrow \mathbf{R}$ is an isomorphism.

Exercise 8.8.1 Check that the determinant actually is an alternating form and an isomorphism.

Definition 8.8.2 An *orientation* on a k -dimensional vector space V is an equivalence class of bases on V , where (v_1, \dots, v_k) and (w_1, \dots, w_k) are equivalent if $v_1 \wedge \dots \wedge v_k$ and $w_1 \wedge \dots \wedge w_k$ differ by a positive scalar. The equivalence class, or *orientation class*, represented by a basis (v_1, \dots, v_k) is written $[v_1, \dots, v_k]$.

Note 8.8.3 That two bases $v_1 \wedge \dots \wedge v_k$ and $w_1 \wedge \dots \wedge w_k$ in \mathbf{R}^k define the same orientation class can be formulated by means of the determinant:

$$\det(v_1 \dots v_k) / \det(w_1 \dots w_k) > 0$$

as a matter of fact, this formula is valid for any k -dimensional vector space if you choose an isomorphism $V \rightarrow \mathbf{R}^k$ (the choice turns out not to matter).

Note 8.8.4 On a vector space V there are exactly two orientations. For instance, on \mathbf{R}^k the two orientations are $[e_1, \dots, e_k]$ and $[-e_1, e_2, \dots, e_k] = [e_2, e_1, e_3, \dots, e_k]$.

Note 8.8.5 An *isomorphism* of vector spaces $f: V \rightarrow W$ sends an orientation $\mathcal{O} = [v_1, \dots, v_k]$ to the orientation $f\mathcal{O} = [f(v_1), \dots, f(v_k)]$.

Definition 8.8.6 An *oriented vector space* is a vector space together with a chosen orientation. An isomorphism of oriented vector spaces either *preserve* or *reverse* the orientation.

Definition 8.8.7 Let $E \rightarrow X$ be a vector bundle. An *orientation* on $E \rightarrow X$ is a family $\mathcal{O} = \{\mathcal{O}_p\}_{p \in X}$ such that \mathcal{O}_p is an orientation on the fiber E_p , and such that around any point $p \in X$ there is a bundle chart (h, U) such that for all $q \in U$ the isomorphism

$$h_q: E_q \rightarrow \mathbf{R}^k$$

sends \mathcal{O}_q to $h_p \mathcal{O}_p$.

Definition 8.8.8 A vector bundle is *orientable* if it can be equipped with an orientation.

Example 8.8.9 A trivial bundle is orientable.

Example 8.8.10 Not all bundles are orientable, for instance, the canonical line bundle $\eta_1 \rightarrow S^1$ is not orientable: start choosing orientations, run around the circle, and have a problem.

Definition 8.8.11 A manifold M is *orientable* if the tangent bundle is orientable.

8.9 An aside on Grassmann manifolds

This section is not used anywhere else and may safely be skipped. It focuses on a particularly interesting set of manifolds, namely the Grassmann manifolds. Their importance

to bundle theory stem from the fact that in certain precise sense the bundles over a given manifold M is classified by a set of equivalence classes from M into Grassmann manifolds. This is really cool, but unfortunately beyond the scope of our current investigations.

Exercise 8.9.1 The following exercises are rather hard, so it is fully legal just to use them as vague orientation into interesting stuff we can't pursue to the depths it deserves.

The *Grassmann manifold* G_n^k is defined as a set to be the set of all k -dimensional linear subspaces of \mathbf{R}^n . This may be given the structure of a smooth manifold (note that the case $k = 1$ is the real projective space).

First we identify G_n^k with the quotient space of V_n^k , where two k -frames $F, F' \in M_{nk}(\mathbf{R})$ are said to be equivalent if there is an $A \in O(k)$ such that $F = F'A$. This gives a topology on G_n^k (check that it is Hausdorff by using the distance from a k -plane to a point).

We have to make charts. Let $g \in O(n)$, and let

$$y_g: M_{k \times (n-k)}(\mathbf{R}) \cong \mathbf{R}^{n(n-k)} \rightarrow G_n^k$$

$$A = [a_{ij}] \mapsto \text{span} \left\{ ge_i + \sum_{j=1}^k a_{ij} ge_{j+k} \right\}$$

and let U_g be the image of y_g . These will be the inverses of our charts.

As a masochistic exercise in linear algebra you may prove that this defines a smooth manifold structure on G_n^k .

Exercise 8.9.2 Define the *canonical k -plane bundle* over the Grassmann manifold

$$\gamma_n^k \rightarrow G_n^k$$

by setting

$$\gamma_n^k = \{(E, v) | E \in G_n^k, v \in E\}$$

(note that $\gamma_n^1 = \eta_n \rightarrow \mathbf{RP}^n = G_n^1$). (hint: use the charts in the previous exercise, and let

$$h_g: \pi^{-1}(U_g) \rightarrow U_g \times \mathbf{E}_g$$

send (E, v) to $(E, pr_{E_g} v)$).

Note 8.9.3 The Grassmann manifolds are important because there is a neat way to describe vector bundles as maps from manifolds into Grassmann manifolds, which makes their global study much more transparent. We won't have the occasion to study this phenomenon, but we include the following example.

Exercise 8.9.4 Let $M \subseteq \mathbf{R}^n$ be a smooth k -dimensional manifold. Then we define the *generalized Gauss map*

$$\begin{array}{ccc} TM & \longrightarrow & \gamma_n^k \\ \downarrow & & \downarrow \\ M & \longrightarrow & G_n^k \end{array}$$

by sending $p \in M$ to $T_p M \in G_n^k$, and $[\gamma] \in TM$ to $(T_{\gamma(0)} M, [\gamma])$. Check that it is a bundle morphism.

Chapter 9

Differential equations and flows

Many applications lead to situations where you end up with a differential equation on some manifold. Solving these are no easier than it is in the flat case. However, the language of tangent bundles can occasionally make it clearer what is going on, and where the messy formulas actually live.

Furthermore, the existence of solutions to differential equations are essential to show that the deformations we naturally accept performed on manifolds actually make sense smoothly. This is reflected in that the flows we construct are smooth.

Example 9.0.5 In the flat case, we are used to draw “flow charts”. E.g., given a first order differential equation

$$\begin{bmatrix} x'(t) \\ y'(t) \end{bmatrix} = f(x(t), y(t))$$

we associate to each point (x, y) the vector $f(x, y)$. In this fashion a first order ordinary differential equation may be identified with a vector field. Each vector would be the velocity vector of a solution to the equation passing through the point (x, y) . If f is smooth, the vectors will depend smoothly on the point (it is a smooth vector field), and the picture would resemble a flow of a liquid, where each vector would represent the velocity of the particle at the given point. The paths of each particle would be solutions of the differential equation, and assembling all these solutions, we could talk about the flow of the liquid.

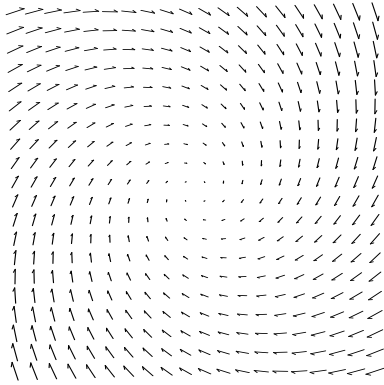

The vector field resulting from a system of ordinary differential equations (here: a predator-prey system with a stable equilibrium).

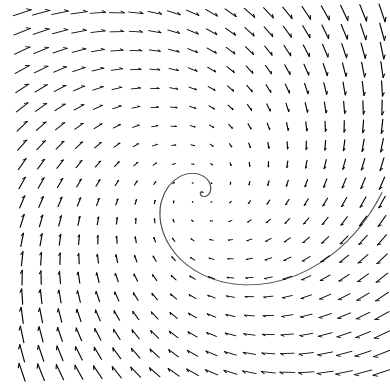

A solution to the differential equation is a curve whose derivative equals the corresponding vector field.

9.1 Flows and velocity fields

If we are to talk about differential equations on manifolds, the confusion of where the velocity fields live (as opposed to the solutions) has to be sorted out. The place of velocity vectors is the tangent bundle, and a differential equation can be represented by a vector field, that is a section in the tangent bundle $TM \rightarrow M$, and its solutions by a “flow”:

Definition 9.1.1 Let M be a smooth manifold. A (*global*) *flow* is a smooth map

$$\Phi: \mathbf{R} \times M \rightarrow M$$

such that for all $p \in M$ and $s, t \in \mathbf{R}$

- $\Phi(0, p) = p$
- $\Phi(s, \Phi(t, p)) = \Phi(s + t, p)$

We are going to show that on a compact manifold there is a one-to-one correspondence between vector fields and global flows. In other words, first order ordinary differential equations have unique solutions on compact manifolds. This statement is true also for non-compact manifolds, but then we can't expect the flows to be defined on all of $\mathbf{R} \times M$ anymore, and we have to talk about *local flows*. We will return to this later, but first we will familiarize ourselves with global flows.

Definition 9.1.2 Let $M = \mathbf{R}$, let

$$L: \mathbf{R} \times \mathbf{R} \rightarrow \mathbf{R}$$

be the flow given by $L(s, t) = s + t$.

Example 9.1.3 Consider the map

$$\Phi: \mathbf{R} \times \mathbf{R}^2 \rightarrow \mathbf{R}^2$$

given by

$$\left(t, \begin{bmatrix} p \\ q \end{bmatrix} \right) \mapsto e^{-t/2} \begin{bmatrix} \cos t & \sin t \\ -\sin t & \cos t \end{bmatrix} \begin{bmatrix} p \\ q \end{bmatrix}$$

Exercise 9.1.4 Check that this actually is a global flow!

For fixed p and q this is the solution to the initial value problem

$$\begin{bmatrix} x' \\ y' \end{bmatrix} = \begin{bmatrix} -1/2 & 1 \\ -1 & -1/2 \end{bmatrix} \begin{bmatrix} x \\ y \end{bmatrix}, \quad \begin{bmatrix} x(0) \\ y(0) \end{bmatrix} = \begin{bmatrix} p \\ q \end{bmatrix}$$

whose corresponding vector field was used in the figures in example 9.0.5.

A flow is a very structured representation of a vector field:

Definition 9.1.5 Let Φ be a flow on the smooth manifold M . The *velocity field* of Φ is defined to be the vector field

$$\vec{\Phi}: M \rightarrow TM$$

where $\vec{\Phi}(p) = [t \mapsto \Phi(t, p)]$.

The surprise is that *every* vector field is the velocity field of a flow (see the integrability theorems 9.2.2 and 9.4.2)

Example 9.1.6 Consider the global flow of 9.1.2. Its velocity field

$$\vec{L}: \mathbf{R} \rightarrow T\mathbf{R}$$

is given by $s \mapsto [L_s]$ where L_s is the curve $t \mapsto L_s(t) = L(s, t) = s + t$. Under the diffeomorphism

$$T\mathbf{R} \rightarrow \mathbf{R} \times \mathbf{R}, \quad [\omega] \mapsto (\omega(0), \omega'(0))$$

we see that \vec{L} is the non-vanishing vector field corresponding to picking out 1 in every fiber.

Example 9.1.7 Consider the flow Φ in 9.1.3. Under the diffeomorphism

$$T\mathbf{R}^2 \rightarrow \mathbf{R}^2 \times \mathbf{R}^2, \quad [\omega] \mapsto (\omega(0), \omega'(0))$$

the velocity field $\vec{\Phi}: \mathbf{R}^2 \rightarrow T\mathbf{R}^2$ corresponds to

$$\mathbf{R}^2 \rightarrow \mathbf{R}^2 \times \mathbf{R}^2, \quad \begin{bmatrix} p \\ q \end{bmatrix} \mapsto \left(\begin{bmatrix} p \\ q \end{bmatrix}, \begin{bmatrix} -1/2 & 1 \\ -1 & -1/2 \end{bmatrix} \begin{bmatrix} p \\ q \end{bmatrix} \right)$$

Definition 9.1.8 Let Φ be a global flow on a smooth manifold M , and $p \in M$. The curve

$$\mathbf{R} \rightarrow M, \quad t \mapsto \Phi(t, p)$$

is called the *flow line* of Φ through p . The image $\Phi(\mathbf{R}, p)$ of this curve is called the *orbit* of p .

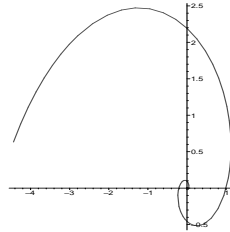

The orbit of the point $\begin{bmatrix} 1 \\ 0 \end{bmatrix}$ of the flow of example 9.1.3.

The orbits split the manifold into disjoint sets:

Proposition 9.1.9 *Let*

$$\Phi: \mathbf{R} \times M \rightarrow M$$

be a flow on a smooth manifold M . Then

$$p \sim q \Leftrightarrow \text{there is a } t \text{ such that } \Phi(t, p) = q$$

defines an equivalence relation on M .

Proof: Symmetry ($\Phi(0, p) = p$) and reflexivity ($\Phi(-t, \Phi(t, p)) = p$) are obvious, and transitivity follows since if

$$p_{i+1} = \Phi(t_i, p_i), \quad i = 0, 1$$

then

$$p_2 = \Phi(t_1, p_1) = \Phi(t_1, \Phi(t_0, p_0)) = \Phi(t_1 + t_0, p_0)$$

■

Example 9.1.10 The flow line through 0 of the flow L of definition 9.1.2 is the identity on \mathbf{R} . The only orbit is \mathbf{R} .

More interesting: the flow lines of the flow of example 9.1.3 are of two types: the constant flow line at the origin, and the spiralling flow lines filling out the rest of the space.

Note 9.1.11 (Contains important notation, and a reinterpretation of the term “global flow”). Writing $\Phi_t(p) = \Phi(t, p)$ we get another way of expressing a flow. To begin with we have

- $\Phi_0 = \text{identity}$
- $\Phi_{s+t} = \Phi_s \circ \Phi_t$

We see that for each t the map Φ_t is a diffeomorphism (with inverse Φ_{-t}) from M to M . The assignment $t \mapsto \Phi_t$ sends sum to composition of diffeomorphisms and so defines a “group homomorphism”

$$\mathbf{R} \rightarrow \text{Diff}(M)$$

from the additive group of real numbers to the group of diffeomorphism (under composition) on M .

We have already used this notation in connection with the flow L of definition 9.1.2: $L_s(t) = L(s, t) = s + t$.

Lemma 9.1.12 *Let Φ be a global flow on M and $s \in \mathbf{R}$. Then the diagram*

$$\begin{array}{ccc} TM & \xrightarrow[T\Phi_s]{\cong} & TM \\ \vec{\Phi} \uparrow & & \vec{\Phi} \uparrow \\ M & \xrightarrow[M\Phi_s]{\cong} & M \end{array}$$

commutes.

Proof: One of the composites sends $q \in M$ to $[t \mapsto \Phi(s, \Phi(t, q))]$ and the other sends $q \in M$ to $[t \mapsto \Phi(t, \Phi(s, q))]$. ■

Definition 9.1.13 Let

$$\gamma: \mathbf{R} \rightarrow M$$

be a smooth curve on the manifold M . The *velocity vector* $\dot{\gamma}(s) \in T_{\gamma(s)}M$ of γ at $s \in \mathbf{R}$ is defined as the tangent vector

$$\dot{\gamma}(s) = T\gamma \vec{L}(s) = [\gamma L_s] = [t \mapsto \gamma(s + t)]$$

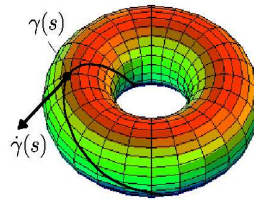

The velocity vector $\dot{\gamma}(s)$ of the curve γ at s lives in $T_{\gamma(s)}M$.

Note 9.1.14 The curve γL_s is given by $t \mapsto \gamma(s + t)$. The term velocity vector becomes easier to understand when we interpret it as a derivation: if $\bar{\phi}: (M, \gamma(s)) \rightarrow (\mathbf{R}, \phi\gamma(s))$ is a function germ, then the derivation corresponding to the velocity vector sends $\bar{\phi}$ to

$$X_{\gamma L_s}(\bar{\phi}) = (\phi\gamma L_s)'(0) = (\phi\gamma)'(s)$$

The following diagram can serve as a reminder for the construction and will be used later:

$$\begin{array}{ccc} T\mathbf{R} & \xrightarrow{T\gamma} & TM \\ \vec{L} \uparrow & \nearrow \dot{\gamma} & \downarrow \\ \mathbf{R} & \xrightarrow{\gamma} & M \end{array}$$

The velocity field and the flow are intimately connected, and the relation can be expressed in many ways. Here are some:

Lemma 9.1.15 *Let Φ be a flow on the smooth manifold M , $p \in M$. Let ϕ_p be the flow line through p given by $\phi_p(s) = \Phi(s, p)$. Then the diagrams*

$$\begin{array}{ccc} \mathbf{R} & \xrightarrow{\phi_p} & M \\ L_s \downarrow \cong & & \Phi_s \downarrow \cong \\ \mathbf{R} & \xrightarrow{\phi_p} & M \end{array}$$

and

$$\begin{array}{ccc} T\mathbf{R} & \xrightarrow{T\phi_p} & TM \\ \vec{L} \uparrow & \nearrow \dot{\phi}_p & \uparrow \vec{\Phi} \\ \mathbf{R} & \xrightarrow{\phi_p} & M \end{array}$$

commutes. For future reference, we have for all $s \in \mathbf{R}$ that

$$\begin{aligned} \dot{\phi}_p(s) &= \vec{\Phi}(\phi_p(s)) \\ &= T\Phi_s[\dot{\phi}_p] \end{aligned}$$

Proof: All these claims are variations of the fact that

$$\Phi(s+t, q) = \Phi(s, \Phi(t, q)) = \Phi(t, \Phi(s, q))$$

■

Proposition 9.1.16 *Let Φ be a flow on a smooth manifold M , and $p \in M$. If*

$$\gamma: \mathbf{R} \rightarrow M$$

is the flow line of Φ through p (i.e., $\gamma(t) = \Phi(t, p)$) then either

- *γ is an injective immersion*
- *γ is a periodic immersion (i.e., there is a $T > 0$ such that $\gamma(s) = \gamma(t)$ if and only if there is an integer k such that $s = t + kT$), or*
- *γ is constant.*

Proof: Note that since $T\Phi_s\dot{\gamma}(0) = T\Phi_s[\dot{\gamma}] = \dot{\gamma}(s)$ and Φ_s is a diffeomorphism $\dot{\gamma}(s)$ is either zero for all s or never zero at all.

If $\dot{\gamma}(s) = 0$ for all s , this means that γ is constant since for all function germs $\bar{\phi}: (M, \gamma(s)) \rightarrow (\mathbf{R}, \phi\gamma(s))$ we get $(\phi\gamma)' = 0$.

If $\dot{\gamma}(s) = T\gamma[L_s]$ is never zero we get that $T\gamma$ is injective (since $[L_s] \neq 0 \in T_s\mathbf{R} \cong \mathbf{R}$), and so γ is an immersion. Either it is injective, or there are two numbers $s > s'$ such that $\gamma(s) = \gamma(s')$. This means that

$$\begin{aligned} p = \gamma(0) &= \Phi(0, p) = \Phi(s-s, p) = \Phi(s, \Phi(-s, p)) \\ &= \Phi(s, \gamma(-s)) = \Phi(s, \gamma(-s')) = \Phi(s-s', p) \\ &= \gamma(s-s') \end{aligned}$$

Since γ is continuous $\gamma^{-1}(p) \subseteq \mathbf{R}$ is closed and not empty (it contains 0 and $s-s' > 0$ among others). As γ is an immersion it is a local imbedding, so there is an $\epsilon > 0$ such that

$$(-\epsilon, \epsilon) \cap \gamma^{-1}(0) = \{0\}$$

Hence

$$S = \{t > 0 | p = \gamma(t)\} = \{t \geq \epsilon | p = \gamma(t)\}$$

is closed and bounded below. This means that there is a smallest positive number T such that $\gamma(0) = \gamma(T)$. Clearly $\gamma(t) = \gamma(t+kT)$ for all $t \in \mathbf{R}$ and any integer k .

On the other hand we get that $\gamma(t) = \gamma(t')$ **only if** $t-t' = kT$ for some integer k . For if $(k-1)T < t-t' < kT$, then $\gamma(0) = \gamma(kT - (t-t'))$ with $0 < kT - (t-t') < T$ contradicting the minimality of T . ■

Note 9.1.17 In the case the flow line is a periodic immersion we note that γ must factor through an imbedding $f: S^1 \rightarrow M$ with $f(e^{it}) = \gamma(tT/2\pi)$. That it is an imbedding follows since it is an injective immersion from a compact space.

In the case of an injective immersion there is no reason to believe that it is an imbedding.

Example 9.1.18 The flow lines in example 9.1.3 are either constant (the one at the origin) or injective immersions (all the others). The flow

$$\Phi: \mathbf{R} \times \mathbf{R}^2 \rightarrow \mathbf{R}^2, \quad \left(t, \begin{bmatrix} x \\ y \end{bmatrix} \right) \mapsto \begin{bmatrix} \cos t & -\sin t \\ \sin t & \cos t \end{bmatrix} \begin{bmatrix} x \\ y \end{bmatrix}$$

has periodic flow lines (except at the origin).

Exercise 9.1.19 Display an injective immersion $f: \mathbf{R} \rightarrow \mathbf{R}^2$ which is not the flow line of a flow.

9.2 Integrability: compact case

A difference between vector fields and flows is that vector fields can obviously be added, which makes it easy to custom build vector fields for a particular purpose. That this is true also for flows is far from obvious, but is one of the nice consequences of the integrability theorem 9.2.2 below. The importance of the theorem is that we may custom-build flows for particular purposes simply by specifying their velocity fields.

Going from flows to vector fields is simple: just take the velocity field. The other way is harder, and relies on the fact that first order ordinary differential equations have unique solutions.

Definition 9.2.1 Let $X: M \rightarrow TM$ be a vector field. A *solution curve* is a curve $\gamma: J \rightarrow M$ (where J is an open interval) such that $\dot{\gamma}(t) = X(\gamma(t))$ for all $t \in J$.

We note that the equation

$$\dot{\phi}_p(s) = \vec{\Phi}(\phi_p(s))$$

of lemma 9.1.15 says that “the flow lines are solution curves to the velocity field”. This is the key to proof of the integrability theorem:

Theorem 9.2.2 *Let M be a smooth compact manifold. Then the velocity field gives a natural bijection between the sets*

$$\{\text{global flows on } M\} \leftrightarrow \{\text{vector fields on } M\}$$

Proof: Given a vector field X on M we will produce a unique flow Φ whose vector field is $\vec{\Phi} = X$.

We problem hinges on a local question which we refer away to analysis (although the proof contains nice topological stuff). Given a point $p \in M$ choose a chart $x = x_p: U \rightarrow U'$ with $p \in U$. Define $f: U' \rightarrow \mathbf{R}^n$ as the composite given by the diagram

$$\begin{array}{ccccc} TU & \xrightarrow[\cong]{Tx} & TU' & \xrightarrow[\cong]{} & U' \times \mathbf{R}^n & \xrightarrow{pr_{\mathbf{R}^n}} & \mathbf{R}^n \\ & & \uparrow x|_U & & & & \\ & & U & \xrightarrow[\cong]{x} & U' & & \end{array}$$

(here the topmost composite sends $[\omega]$ to $(x\omega)'(0)$, and in particular $\dot{\gamma}(t) = [\gamma L_t]$ to $(x\gamma)'(t)$). Then we get that claiming that a curve $\gamma: J \rightarrow U$ is a solution curve to X , i.e. satisfies the equation

$$\dot{\gamma}(t) = X(\gamma(t)),$$

is equivalent to claiming that

$$(x\gamma)'(t) = f(x\gamma(t)).$$

By the existence and uniqueness theorem for first order differential equations cited in the analysis appendix 11.3.1 there is a neighborhood $J_p \times V'_p$ around $(0, x(p)) \in \mathbf{R} \times U'$ for which there exists a smooth map

$$\Psi: J_p \times V'_p \rightarrow U'_p$$

such that

- $\Psi(0, q) = q$ for all $q \in V'_p$ and
- $\frac{\partial}{\partial t}\Psi(t, q) = f(\Psi(t, q))$ for all $(t, q) \in J_p \times V'_p$.

and furthermore for each $q \in V'_p$ the curve $\Psi(-, q): J_p \rightarrow U'_p$ is unique with respect to this property.

The set of open sets of the form $x_p^{-1}V'_p$ is an open cover of M , and hence we may choose a finite subcover. Let J be the intersection of the J_p 's corresponding to this finite cover. Since it is a finite intersection J contains an open interval $(-\epsilon, \epsilon)$ around 0.

This defines a smooth map

$$\tilde{\Phi}: J \times M \rightarrow M$$

by $\tilde{\Phi}(t, q) = x^{-1}\Psi(t, xq)$ (this is well defined and smooth by the uniqueness of solutions).

Note that the uniqueness of solution also gives that

$$\tilde{\Phi}(t, \tilde{\Phi}(s, q)) = \tilde{\Phi}(s + t, q)$$

for $|s|$, $|t|$ and $|s + t|$ less than ϵ .

But this also means that we may extend the domain of definition to get a map

$$\Phi: \mathbf{R} \times M \rightarrow M$$

since for any $t \in \mathbf{R}$ there is a natural number k such that $|t/k| < \epsilon$, and we simply define $\Phi(t, q)$ as $\tilde{\Phi}_{t/k}$ applied k times to q . ■

The condition that M was compact was crucial to this proof. A similar statement is true for noncompact manifolds, and we will return to that statement later.

Exercise 9.2.3 Given two flows Φ and Ψ on the sphere S^2 . Why does there exist a flow which is Φ close to the North pole, and Ψ close to the South pole?

Exercise 9.2.4 Construct vector fields on the torus such that the solution curves are all either

- imbedded circles, or
- dense immersions.

Exercise 9.2.5 Let $O(n)$ be the orthogonal group, and recall from exercise 6.4.12 the isomorphism between the tangent bundle of $O(n)$ and the projection on the first factor

$$E = \{(g, A) \in O(n) \times M_n(\mathbf{R}) \mid A^t = -g^t A g^t\} \rightarrow O(n).$$

Choose a skew matrix $A \in M_n(\mathbf{R})$ (i.e. such that $A^t = -A$), and consider the vector field $X: O(n) \rightarrow TO(n)$ induced by

$$\begin{aligned} O(n) &\rightarrow E \\ g &\mapsto (g, gA) \end{aligned}$$

Show that the flow associated to X is given by $\Phi(s, g) = ge^{sA}$ where the exponential is defined as usual by $e^B = \sum_{j=0}^{\infty} \frac{B^j}{j!}$.

9.3 Local flows

We now make the necessary modifications for the non-compact case.

On manifolds that are not compact, the concept of a flow is not the correct one. This can be seen by considering a global field Φ on some manifold M and restricting it to some open submanifold U . Then some of the flow lines may leave U after finite time. To get a “flow” Φ_U on U we must then accept that Φ_U is only defined on some open subset of $\mathbf{R} \times U$ containing $\{0\} \times U$.

Also, if we jump ahead a bit, and believe that flows should correspond to general solutions to first order ordinary differential equations (that is vector fields), you may consider the differential equation

$$y' = y^2, \quad y(0) = y_0$$

on $M = \mathbf{R}$ (the corresponding vector field is $\mathbf{R} \rightarrow T\mathbf{R}$ given by $s \mapsto [t \mapsto s + s^2t]$).

Here the solution is of the type

$$y(t) = \begin{cases} \frac{1}{1/y_0 - t} & \text{if } y_0 \neq 0 \\ 0 & \text{if } y_0 = 0 \end{cases}$$

and the domain of the “flow”

$$\Phi(t, p) = \begin{cases} \frac{1}{1/p - t} & \text{if } p \neq 0 \\ 0 & \text{if } p = 0 \end{cases}$$

is

$$A = \{(t, p) \in \mathbf{R} \times \mathbf{R} \mid pt < 1\}$$

Definition 9.3.1 Let M be a smooth manifold. A *local flow* is a smooth map

$$\Phi: A \rightarrow M$$

where $A \subseteq \mathbf{R} \times M$ is open and contains $\{0\} \times M$, such that for each $p \in M$

$$J_p \times \{p\} = A \cap (\mathbf{R} \times \{p\})$$

is connected and such that

- $\Phi(0, p) = p$
- $\Phi(s, \Phi(t, p)) = \Phi(s + t, p)$

for all $p \in M$ such that (t, p) , $(s + t, p)$ and $(s, \Phi(t, p))$ are in A .

For each $p \in M$ we define $-\infty \leq a_p < 0 < b_p \leq \infty$ by $J_p = (a_p, b_p)$.

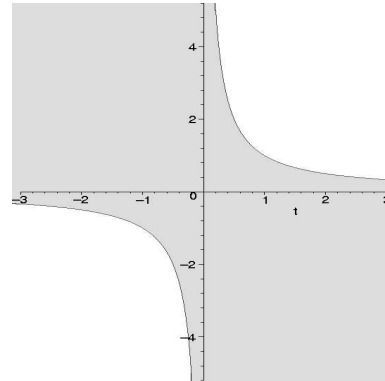

The domain A of the “flow”. It contains an open neighborhood around $\{0\} \times M$

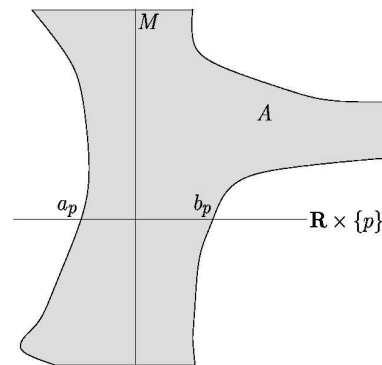

The domain A of a local flow contains $\{0\} \times M$. For every $p \in M$ the intersection $J_p = A \cap (\mathbf{R} \times \{p\})$ is connected.

Note 9.3.2 The definitions of the *velocity field*

$$\vec{\Phi}: M \rightarrow TM$$

(the tangent vector $\vec{\Phi}(p) = [t \mapsto \Phi(t, p)]$ only depends on the values of the curve in a small neighborhood of 0), the *flow lines*

$$\Phi(-, p): J_p \rightarrow M, \quad t \mapsto \Phi(t, p)$$

and the *orbits*

$$\Phi(J_p, p) \subseteq M$$

and makes just as much sense for a local flow Φ .

However, we can't talk about "the diffeomorphism Φ_t " since there may be $p \in M$ such that $(t, p) \notin A$, and so Φ_t is not defined on all of M .

Example 9.3.3 Check that the proposed flow

$$\Phi(t, p) = \begin{cases} \frac{1}{1/p-t} & \text{if } p \neq 0 \\ 0 & \text{if } p = 0 \end{cases}$$

is a local flow with velocity field $\vec{\Phi}: \mathbf{R} \rightarrow T\mathbf{R}$ given by $s \mapsto [t \mapsto \Phi(t, s)]$ (which under the standard trivialization

$$T\mathbf{R} \xrightarrow{[\omega \mapsto (\omega(0), \omega'(0))]} \mathbf{R} \times \mathbf{R}$$

correspond to $s \mapsto (s, s^2)$ – and so $\vec{\Phi}(s) = [t \mapsto \Phi(t, s)] = [t \mapsto s + s^2 t]$ with domain

$$A = \{(t, p) \in \mathbf{R} \times \mathbf{R} \mid pt < 1\}$$

and so $a_p = 1/p$ for $p < 0$ and $a_p = -\infty$ for $p \geq 0$. Note that Φ_t only makes sense for $t = 0$.

9.4 Integrability

Definition 9.4.1 A local flow $\Phi: A \rightarrow M$ is *maximal* if there is no local flow $\Psi: B \rightarrow M$ such that $A \subsetneq B$ and $\Psi|_A = \Phi$.

Theorem 9.4.2 Let M be a smooth manifold. Then the velocity field gives a natural bijection between the sets

$$\{\text{maximal local flows on } M\} \leftrightarrow \{\text{vector fields on } M\}$$

Proof: The essential idea is the same as in the compact case, but we have to worry a bit more about the domain of definition of our flow. The local solution to the ordinary differential equation means that we have unique maximal solution curves

$$\phi_p: J_p \rightarrow M$$

for all p , and two solution curves agree on their intersection since the set of points where they agree is closed by continuity, but also open by the local uniqueness of solutions. This also means that the curves $t \mapsto \phi_p(s+t)$ and $t \mapsto \phi_{\phi_p(s)}(t)$ agree, and we define

$$\Phi: A \rightarrow M$$

by setting

$$A = \bigcup_{p \in M} J_p \times \{p\}, \text{ and } \Phi(t, p) = \phi_p(t)$$

The only questions are whether A is open and Φ is smooth. But this again follow from the local existence theorems: around any point in A there is a neighborhood on which Φ correspond to the unique local solution (see [BJ] page 82 and 83 for more details). ■

Corollary 9.4.3 *Let $K \subset M$ be a compact subset of a smooth manifold M , and let Φ be a maximal local flow on M such that $b_p < \infty$. Then there is an $\epsilon > 0$ such that $\Phi(t, p) \notin K$ for $t > b_p - \epsilon$.*

Proof: Since K is compact there is an $\epsilon > 0$ such that

$$[-\epsilon, \epsilon] \times K \subseteq A \cap (\mathbf{R} \times K)$$

If $\Phi(t, p) \in K$ for $t < T$ where $T > b_p - \epsilon$ then we would have that Φ could be extended to $T + \epsilon > b_p$ by setting

$$\Phi(t, p) = \Phi(\epsilon, \Phi(t - \epsilon, p))$$

for all $T \leq t < T + \epsilon$. ■

Note 9.4.4 Some readers may worry about the fact that we do not consider “time dependent” differential equations, but by a simple trick as in [S] page 226, these are covered by our present considerations.

Exercise 9.4.5 Find a nonvanishing vector field on \mathbf{R} whose solution curves are only defined on finite intervals.

9.5 Ehresmann's fibration theorem

We have studied quite intensely what consequences it has that a map $f: M \rightarrow N$ is an immersion. In fact, adding the point set topological property that $M \rightarrow f(M)$ is a homeomorphism we got that f was an imbedding.

We are now ready to discuss submersions (which by definition said that all points were regular). It turns out that adding a point set property we get that submersions are also rather special: they look like vector bundles, except that the fibers are not vector spaces, but manifolds!

Definition 9.5.1 Let $f: E \rightarrow M$ be a smooth map. We say that f is a *locally trivial fibration* if for each $p \in M$ there is an open neighborhood U and a diffeomorphism

$$h: f^{-1}(U) \rightarrow U \times f^{-1}(p)$$

such that

$$\begin{array}{ccc} f^{-1}(U) & \xrightarrow{h} & U \times f^{-1}(p) \\ & \searrow f|_{f^{-1}(U)} & \swarrow pr_U \\ & U & \end{array}$$

commutes.

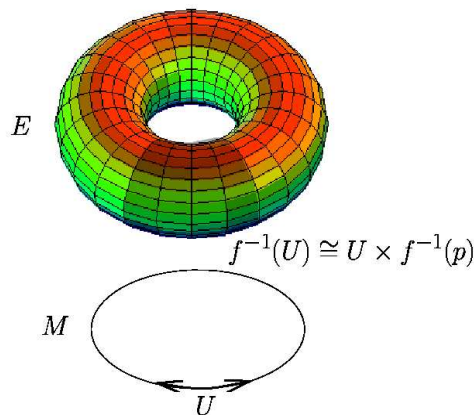

Over a small $U \in M$ a locally trivial fibration looks like the projection $U \times f^{-1}(p) \rightarrow U$ (the picture is kind of misleading, since the projection $S^1 \times S^1 \rightarrow S^1$ is **globally** of this kind).

Example 9.5.2 The projection of the torus down to a circle which is illustrated above is kind of misleading since the torus is globally a product. However, due to the scarcity of compact two-dimensional manifolds, the torus is the only example which can be imbedded in \mathbf{R}^3 . However, there are nontrivial examples we can envision: for instance, the projection of the Klein bottle onto its “central circle” (see illustration to the right) is a nontrivial example.

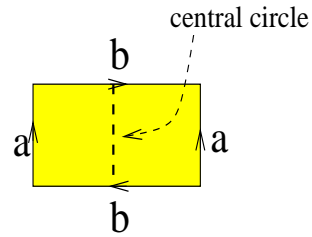

The projection from the Klein bottle onto its “central circle” is a locally trivial fibration

Definition 9.5.3 A continuous map $f: X \rightarrow Y$ is *proper* if the inverse image of compact subsets are compact.

Theorem 9.5.4 (*Ehresmann’s fibration theorem*) Let $f: E \rightarrow M$ be a proper submersion. Then f is a locally trivial fibration.

Proof: Since the question is local in M , we may start out by assuming that $M = \mathbf{R}^n$. The theorem then follows from lemma 12 below. ■

Note 9.5.5 Before we start with the proof, it is interesting to see what the ideas are.

By the rank theorem a submersion looks locally (in E and M) as a projection

$$\mathbf{R}^{n+k} \rightarrow \mathbf{R}^n \times \{0\} \cong \mathbf{R}^n$$

and so locally all submersions are trivial fibrations. We will use flows to glue all these pieces together using partitions of unity.

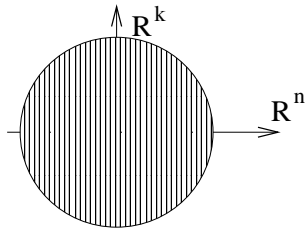

Locally a submersion looks like the projection from \mathbf{R}^{n+k} down onto \mathbf{R}^n .

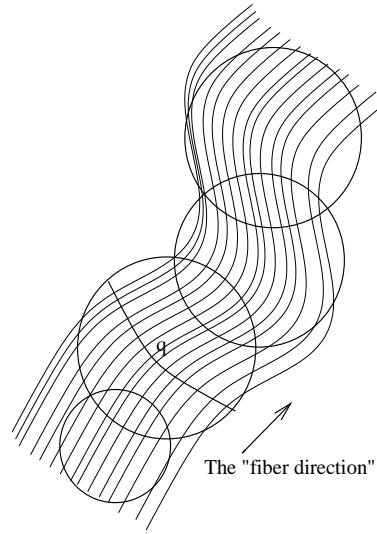

The idea of the proof: make a “flow” that flows transverse to the fibers: locally ok, but can we glue these pictures together?

The clue is then that a point $(t, q) \in \mathbf{R}^n \times f^{-1}(p)$ should correspond to what you get if you flow away from q , first a time t_1 in the first coordinate direction, then a time t_2 in the second and so on.

Lemma 9.5.6 *Let $f: E \rightarrow \mathbf{R}^n$ be a proper submersion. Then there is a diffeomorphism $h: E \rightarrow \mathbf{R}^n \times f^{-1}(0)$ such that*

$$\begin{array}{ccc} E & \xrightarrow{h} & \mathbf{R}^n \times f^{-1}(0) \\ & \searrow f & \swarrow \text{pr}_{\mathbf{R}^n} \\ & \mathbf{R}^n & \end{array}$$

commutes.

Proof: If E is empty, the lemma holds vacuously since then $f^{-1}(0) = \emptyset$, and $\emptyset = \mathbf{R}^n \times \emptyset$. Disregarding this rather uninteresting case, let $p_0 \in E$ and $r_0 = f(p_0) \in \mathbf{R}^n$. The first half of the rank theorem guarantees that for all $p \in f^{-1}(r_0)$ there are charts $x_p: U_p \rightarrow U'_p$ such that

$$\begin{array}{ccc} U_p & \xrightarrow{f|_{U_p}} & \mathbf{R}^n \\ x_p \downarrow & & \parallel \\ U'_p \subseteq \mathbf{R}^{n+k} & \xrightarrow{\text{pr}} & \mathbf{R}^n \end{array}$$

commutes (the map $\text{pr}: \mathbf{R}^{n+k} \rightarrow \mathbf{R}^n$ is the projection onto the first n coordinates. The permutations of coordinates that were allowed in the rank theorem are unnecessary since $n+k \geq n$).

Choose a partition of unity (see theorem 7.4.1) $\{\phi_j\}$ subordinate to $\{U_p\}$. For every j choose p such that $\text{supp}(\phi_j) \subseteq U_p$, and let $x_j = x_p$ (so that we now are left with only countably many charts).

Define the vector fields (the i th partial derivative in the j th chart)

$$X_{i,j}: U_j \rightarrow TU_j, \quad i = 1, \dots, n$$

by $X_{i,j}(q) = [\omega_{i,j}(q)]$ where

$$\omega_{i,j}(q)(t) = x_j^{-1}(x_j(q) + e_i t)$$

and where $e_i \in \mathbf{R}^n$ is the i th unit vector. Let

$$X_i = \sum_j \phi_j X_{i,j}: E \rightarrow TE, \quad i = 1, \dots, n$$

(a "global version" of the i -th partial derivative).

Notice that since $f(u) = \text{pr } x_j(u)$ for $u \in U_j$ we get that

$$\begin{aligned} f\omega_{i,j}(q)(t) &= f x_j^{-1}(x_j(q) + e_i t) = \text{pr } x_j x_j^{-1}(x_j(q) + e_i t) = \text{pr}(x_j(q) + e_i t) \\ &= f(q) + e_i t \end{aligned}$$

(the last equality uses that $i \leq n$). Since $\sum_j \phi_j(q) = 1$ for all q this gives that

$$\begin{aligned} TfX_i(q) &= \sum_j \phi_j(q)[f\omega_{i,j}(q)] = \sum_j \phi_j(q)[t \mapsto f(q) + e_i t] \\ &= [t \mapsto f(q) + e_i t] \end{aligned}$$

for all $i = 1, \dots, n$.

Let the $\Phi_i: A_i \rightarrow E$ be the local flow corresponding to X_i . Notice that

$$f\Phi_i(t, q) = f(q) + e_i t$$

since both give flows with velocity field TfX_i .

We want to show that $A_i = \mathbf{R} \times E$. Let $J_q = A_i \cap (\mathbf{R} \times \{q\})$. Since $f\Phi_i(t, q) = f(q) + e_i t$ we see that the image of a finite open interval under $f\Phi_i(-, q)$ must be contained in a compact, say K . Hence the image of the finite open interval under $\Phi_i(-, q)$ must be contained in $f^{-1}(K)$ which is compact since f is proper. But if $J_q \neq \mathbf{R}$, then corollary 9.4.3 tells us that $\Phi_i(-, q)$ will leave any given compact in finite time leading to a contradiction.

Hence all the Φ_i defined above are global and we define the diffeomorphism

$$\phi: M \times f^{-1}(r_0) \rightarrow E$$

by

$$\phi(t, q) = \Phi_1(t_1, \Phi_2(t_2, \dots, \Phi_n(t_n, q) \dots)), \quad t = (t_1, \dots, t_n) \in \mathbf{R}^n = M, \quad q \in f^{-1}(r_0)$$

The inverse is given by

$$\begin{aligned} E &\rightarrow M \times f^{-1}(r_0) \\ q &\mapsto (f(q), \Phi_n(-f_n(q), \dots, \Phi_1(-f_1(q), q) \dots)). \end{aligned}$$

Finally, we note that we have also proven that f is surjective, and so we are free in our choice of $r_0 \in \mathbf{R}^n$. Choosing $r_0 = 0$ gives the formulation stated in the lemma. ■

Corollary 9.5.7 (*Ehresmann's fibration theorem, compact case*) *Let $f: E \rightarrow M$ be a submersion of compact smooth manifolds. Then f is a locally trivial fibration.*

Proof: We only need to notice that E being compact forces f to be proper: if $K \subset M$ is compact, it is closed (since M is Hausdorff), and $f^{-1}(K) \subseteq E$ is closed (since f is continuous). But a closed subset of a compact space is compact. ■

Exercise 9.5.8 Consider the projection

$$f: S^3 \rightarrow \mathbf{CP}^1$$

Show that f is a locally trivial fibration. Consider the map

$$\ell: S^1 \rightarrow \mathbf{CP}^1$$

given by sending $z \in S^1 \subseteq \mathbf{C}$ to $[1, z]$. Show that ℓ is an imbedding. Use Ehresmann's fibration theorem to show that the inverse image

$$f^{-1}(\ell S^1)$$

is diffeomorphic to the torus $S^1 \times S^1$. (note: there is a diffeomorphism $S^2 \rightarrow \mathbf{CP}^1$ given by $(a, z) \mapsto [1 + a, z]$, and the composite $S^3 \rightarrow S^2$ induced by f is called the *Hopf fibration* and has many important properties. Among other things it has the truly counterintuitive property of detecting a “three-dimensional hole” in S^2 —which disappears if you give it a second glance!)

Exercise 9.5.9 Let $\gamma: \mathbf{R} \rightarrow M$ be a smooth curve and $f: E \rightarrow M$ a proper submersion. Let $p \in f^{-1}(\gamma(0))$. Show that there is a smooth curve $\sigma: \mathbf{R} \rightarrow E$ such that

$$\begin{array}{ccc} & & E \\ & \nearrow \sigma & \downarrow \\ \mathbf{R} & \xrightarrow{\gamma} & M \end{array}$$

commutes and $\sigma(0) = p$. Show that if the dimensions of E and M agree, then σ is unique. In particular, study the cases $S^n \rightarrow \mathbf{RP}^n$ and $S^{2n+1} \rightarrow \mathbf{CP}^n$.

9.6 Second order differential equations

For a smooth manifold M let $\pi_M: TM \rightarrow M$ be the tangent bundle (just need a decoration on π to show its dependence on M).

Definition 9.6.1 A second order differential equation on a smooth manifold M is a smooth map

$$\xi: TM \rightarrow TTM$$

such that

$$\begin{array}{ccccc} & & TTM & & \\ & T\pi_M \swarrow & \uparrow \xi & \searrow \pi_{TM} & \\ TM & \xleftarrow{=} & TM & \xrightarrow{=} & TM \end{array}$$

commutes.

Note 9.6.2 The $\pi_{TM}\xi = id_{TM}$ just says that ξ is a vector field on TM , it is the other relation $(T\pi_M)\xi = id_{TM}$ which is crucial.

Exercise 9.6.3 The flat case: reference sheet. Make sense of the following remarks, write down your interpretation and keep it for reference.

A curve in TM is an equivalence class of “surfaces” in M , for if $\beta: J \rightarrow TM$ then to each $t \in J$ we have that $\beta(t)$ must be an equivalence class of curves, $\beta(t) = [\omega(t)]$ and we may think of $t \mapsto \{s \mapsto \omega(t)(s)\}$ as a surface if we let s and t move simultaneously. If $U \subseteq \mathbf{R}^n$ is open, then we have the trivializations

$$TU \xrightarrow[\cong]{[\omega] \mapsto (\omega(0), \omega'(0))} U \times \mathbf{R}^n$$

with inverse $(p, v) \mapsto [t \mapsto p + tv]$ (the directional derivative at p in the v th direction) and

$$\begin{aligned} T(TU) & \xrightarrow[\cong]{[\beta] \mapsto (\beta(0), \beta'(0))} T(U) \times (\mathbf{R}^n \times \mathbf{R}^n) \\ & \xrightarrow[\cong]{(\beta(0), \beta'(0)) \mapsto ((\omega(0,0), D_2\omega(0,0)), (D_1\omega(0,0), D_2D_1\omega(0,0)))} (U \times \mathbf{R}^n) \times (\mathbf{R}^n \times \mathbf{R}^n) \end{aligned}$$

with inverse $(p, v_1, v_2, v_3) \mapsto [t \mapsto [s \mapsto \omega(t)(s)]]$ with

$$\omega(t)(s) = p + sv_1 + tv_2 + stv_3$$

Hence if $\gamma: J \rightarrow U$ is a curve, then $\dot{\gamma}$ correspond to the curve

$$J \xrightarrow{t \mapsto (\gamma(t), \gamma'(t))} U \times \mathbf{R}^n$$

and if $\beta: J \rightarrow TU$ corresponds to $t \mapsto (x(t), v(t))$ then $\dot{\beta}$ corresponds to

$$J \xrightarrow{t \mapsto (x(t), v(t), x'(t), v'(t))} U \times \mathbf{R}^n \times \mathbf{R}^n \times \mathbf{R}^n$$

This means that $\ddot{\gamma} = \dot{\dot{\gamma}}$ corresponds to

$$J \xrightarrow{t \mapsto (\gamma(t), \gamma'(t), \gamma''(t), \gamma'''(t))} U \times \mathbf{R}^n \times \mathbf{R}^n \times \mathbf{R}^n$$

Exercise 9.6.4 Show that our definition of a second order differential equation correspond to the usual notion of a second order differential equation in the case $M = \mathbf{R}^n$.

Definition 9.6.5 Given a second order differential equation

$$\xi: TM \rightarrow TTM$$

A curve $\gamma: J \rightarrow M$ is called a *solution curve* for ξ on M if $\dot{\gamma}$ is a solution curve to ξ “on TM ”.

Note 9.6.6 Spelling this out we have that

$$\ddot{\gamma}(t) = \xi(\dot{\gamma}(t))$$

for all $t \in J$. Note the bijection

$$\{\text{solution curves } \beta: J \rightarrow TTM\} \leftrightarrow \{\text{solution curves } \gamma: J \rightarrow M\}, \quad \begin{array}{l} \dot{\gamma} \leftarrow \gamma \\ \beta \mapsto \pi_M \beta \end{array}$$

9.6.7 Aside on the exponential map

This section gives a quick definition of the exponential map from the tangent space to the manifold.

Exercise 9.6.8 (Hard: the existence of “geodesics”) The differential equation $T\mathbf{R}^n \rightarrow T^2\mathbf{R}^n$ corresponding to the map

$$\mathbf{R}^n \times \mathbf{R}^n \rightarrow \mathbf{R}^n \times \mathbf{R}^n \times \mathbf{R}^n \times \mathbf{R}^n, \quad (x, v) \mapsto (x, v, v, 0)$$

has solution curves given by the straight line $t \mapsto x + tv$ (a straight curve has zero second derivative). Prove that you may glue together these straight lines by means of charts and partitions of unity to get a second order differential equation

$$\xi: TM \rightarrow TTM$$

with the property that

$$\begin{array}{ccc} TTM & \xrightarrow{Ts} & TTM \\ s\xi \uparrow & & \uparrow \xi \\ TM & \xrightarrow{s} & TM \end{array}$$

for all $s \in \mathbf{R}$ where $s: TM \rightarrow TM$ is multiplication by s in each fiber.

The significance of the diagram in the previous exercise on geodesics is that “you may speed up (by a factor s) along a geodesic, but the orbit won’t change”.

Exercise 9.6.9 (Definition of the exponential map). Given a second order differential equation $\xi: TM \rightarrow TTM$ as in exercise 9.6.8, consider the corresponding local flow $\Phi: A \rightarrow TM$, define the open neighborhood of the zero section

$$\mathcal{T} = \{[\omega] \in TM \mid 1 \in A \cap (\mathbf{R} \times \{[\omega]\})\}$$

and you may define the *exponential map*

$$\exp: \mathcal{T} \rightarrow M$$

by sending $[\omega] \in TM$ to $\pi_M \Phi(1, [\omega])$.

Essentially \exp says: for a tangent vector $[\omega] \in TM$ start out in $\omega(0) \in M$ in the direction on $\omega'(0)$ and travel a unit in time along the corresponding geodesic.

The exponential map depends on ξ . Alternatively we could have given a definition of \exp using a choice of a Riemannian metric, which would be more in line with the usual treatment in differential geometry.

Chapter 10

Appendix: Point set topology

I have collected a few facts from point set topology. The main focus of this note is to be short and present exactly what we need in the manifold course. Point set topology may be your first encounter of real mathematical abstraction, and can cause severe distress to the novice, but it is kind of macho when you get to know it a bit better. However: keep in mind that the course is about manifold theory, and point set topology is only a means of expressing some (obvious?) properties these manifolds should possess. Point set topology is a powerful tool when used correctly, but it is not our object of study.

If you need more details, consult any of the excellent books listed in the references. The real classics are [B] and [K], but the most widely used these days is [M]. There are also many online textbooks, some of which you may find by following links from the course' home page.

Most of the exercises are not deep and are just rewritings of definitions (which may be hard enough if you are new to the subject) and the solutions short.

If I list a fact without proof, the result **may** be deep and its proof (much too) hard.

10.1 Topologies: open and closed sets

Definition 10.1.1 A *topology* is a family of sets \mathcal{U} closed under finite intersection and arbitrary unions, that is if

if $U, U' \in \mathcal{U}$, then $U \cap U' \in \mathcal{U}$

if $\mathcal{I} \subseteq \mathcal{U}$, then $\bigcup_{U \in \mathcal{I}} U \in \mathcal{U}$.

Note 10.1.2 Note that the set $X = \bigcup_{U \in \mathcal{U}} U$ and $\emptyset = \bigcup_{U \in \emptyset} U$ are members of \mathcal{U} .

Definition 10.1.3 We say that \mathcal{U} is a *topology on X* , that (X, \mathcal{U}) is a *topological space*. Frequently we will even refer to X as a topological space when \mathcal{U} is evident from the context.

Definition 10.1.4 The members of \mathcal{U} are called the *open sets* of X with respect to the topology \mathcal{U} .

A subset C of X is *closed* if the complement $X \setminus C = \{x \in X \mid x \notin C\}$ is open.

Example 10.1.5 An open set on the real line \mathbf{R} is a (possibly empty) union of open intervals. Check that this defines a topology on \mathbf{R} . Check that the closed sets do **not** form a topology on \mathbf{R} .

Definition 10.1.6 A subset of X is called a *neighborhood* of $x \in X$ if it contains an open set containing x .

Lemma 10.1.7 Let (X, \mathcal{T}) be a topological space. Prove that a subset $U \subseteq X$ is open if and only if for all $p \in U$ there is an open set V such that $p \in V \subseteq U$.

Proof: Exercise! ■

Definition 10.1.8 Let (X, \mathcal{U}) be a space and $A \subseteq X$ a subset. Then the *interior* $\text{int } A$ of A in X is the union of all open subsets of X contained in A . The *closure* \bar{A} of A in X is the intersection of all closed subsets of X containing A .

Exercise 10.1.9 Prove that $\text{int } A$ is the biggest open set $U \in \mathcal{U}$ such that $U \subseteq A$, and that \bar{A} is the smallest closed set C in X such that $A \subseteq C$.

Example 10.1.10 If (X, d) is a metric space (i.e. a set X and a symmetric positive definite function

$$d: X \times X \rightarrow \mathbf{R}$$

satisfying the triangle inequality), then X may be endowed with the *metric topology* by letting the open sets be arbitrary unions of open balls (note: given an $x \in X$ and a positive real number $\epsilon > 0$, the *open ϵ -ball centered in x* is the set $B(x, \epsilon) = \{y \in X \mid d(x, y) < \epsilon\}$). Exercise: show that this actually defines a topology.

Exercise 10.1.11 The metric topology coincides with the topology we have already defined on \mathbf{R} .

10.2 Continuous maps

Definition 10.2.1 A *continuous map* (or simply a map)

$$f: (X, \mathcal{U}) \rightarrow (Y, \mathcal{V})$$

is a function $f: X \rightarrow Y$ such that for every $V \in \mathcal{V}$ the inverse image

$$f^{-1}(V) = \{x \in X \mid f(x) \in V\}$$

is in \mathcal{U}

other words: f is continuous if *the inverse images of open sets are open*.

Exercise 10.2.2 Prove that a continuous map on the real line is just what you expect. More generally, if X and Y are metric spaces, considered as topological spaces by giving them the metric topology: show that a map $f: X \rightarrow Y$ is continuous iff the corresponding $\epsilon - \delta$ -horror is satisfied.

Exercise 10.2.3 Let $f: X \rightarrow Y$ and $g: Y \rightarrow Z$ be continuous maps. Prove that the composite $gf: X \rightarrow Z$ is continuous.

Example 10.2.4 Let $f: \mathbf{R}^1 \rightarrow S^1$ be the map which sends $p \in \mathbf{R}^1$ to $e^{ip} = (\cos p, \sin p) \in S^1$. Since $S^1 \subseteq \mathbf{R}^2$, it is a metric space, and hence may be endowed with the metric topology. Show that f is continuous, and also that the image of open sets are open.

Definition 10.2.5 A *homeomorphism* is a continuous map $f: (X, \mathcal{U}) \rightarrow (Y, \mathcal{V})$ with a continuous inverse, that is a continuous map $g: (Y, \mathcal{V}) \rightarrow (X, \mathcal{U})$ with $f(g(y)) = y$ and $g(f(x)) = x$ for all $x \in X$ and $y \in Y$.

Exercise 10.2.6 Prove that $\tan: (-\pi/2, \pi/2) \rightarrow \mathbf{R}$ is a homeomorphism.

Note 10.2.7 Note that being a homeomorphism is **more than** being bijective and continuous. As an example let X be the set of real numbers endowed with the metric topology, and let Y be the set of real numbers, but with the “indiscrete topology”: only \emptyset and Y are open. Then the identity map $X \rightarrow Y$ (sending the real number x to x) is continuous and bijective, but it is **not** a homeomorphism: the identity map $Y \rightarrow X$ is not continuous.

Definition 10.2.8 We say that two spaces are *homeomorphic* if there exists a homeomorphism from one to the other.

10.3 Bases for topologies

Definition 10.3.1 If (X, \mathcal{U}) is a topological space, a subfamily $\mathcal{B} \subseteq \mathcal{U}$ is a *basis for the topology* \mathcal{U} if for each $x \in X$ and each $V \in \mathcal{U}$ with $x \in V$ there is a $U \in \mathcal{B}$ such that

$$x \in U \subseteq V$$

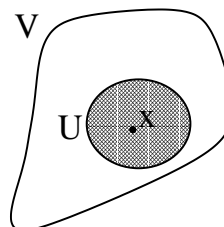

Note 10.3.2 This is equivalent to the condition that each member of \mathcal{U} is a union of members of \mathcal{B} .

Conversely, given a family of sets \mathcal{B} with the property that if $B_1, B_2 \in \mathcal{B}$ and $x \in B_1 \cap B_2$ then there is a $B_3 \in \mathcal{B}$ such that $x \in B_3 \subseteq B_1 \cap B_2$, then \mathcal{B} is a basis for the topology on $X = \bigcup_{U \in \mathcal{B}} U$ given by declaring the open sets to be arbitrary unions from \mathcal{B} . We say that the basis \mathcal{B} *generates* the topology on X .

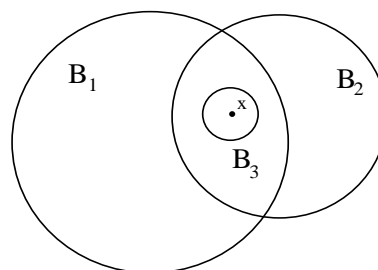

Exercise 10.3.3 The real line has a countable basis for its topology.

Exercise 10.3.4 The balls with rational radius and whose center have coordinates that all are rational form a countable basis for \mathbf{R}^n .

Just to be absolutely clear: a topological space (X, \mathcal{U}) has a *countable basis* for its topology iff there exist a countable subset $\mathcal{B} \subseteq \mathcal{U}$ which is a basis.

Exercise 10.3.5 Let (X, d) be a metric space. Then the open balls form a basis for the metric topology.

Exercise 10.3.6 Let X and Y be topological spaces, and \mathcal{B} a basis for the topology on Y . Show that a function $f: X \rightarrow Y$ is continuous if $f^{-1}(V) \subseteq X$ is open for all $V \in \mathcal{B}$.

10.4 Separation

There are zillions of separation conditions, but we will only be concerned with the most intuitive of all: Hausdorff spaces.

Definition 10.4.1 A topological space (X, \mathcal{U}) is *Hausdorff* if for any two distinct $x, y \in X$ there exist disjoint neighborhoods of x and y .

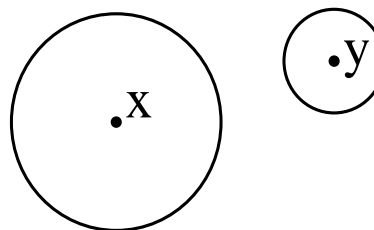

The two points x and y are contained in disjoint open sets.

Example 10.4.2 The real line is Hausdorff.

Example 10.4.3 More generally, the metric topology is always Hausdorff.

10.5 Subspaces

Definition 10.5.1 Let (X, \mathcal{U}) be a topological space. A *subspace* of (X, \mathcal{U}) is a subset $A \subset X$ with the topology given letting the open sets be $\{A \cap U \mid U \in \mathcal{U}\}$.

Exercise 10.5.2 Show that the subspace topology is a topology.

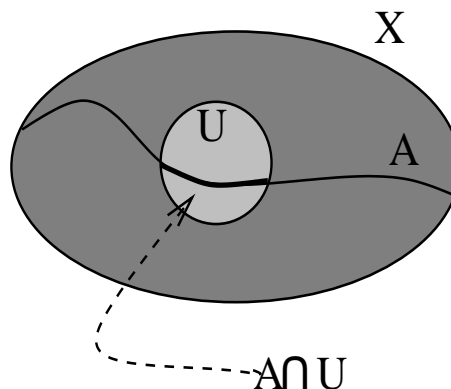

Exercise 10.5.3 Prove that a map to a subspace $Z \rightarrow A$ is continuous iff the composite

$$Z \rightarrow A \subseteq X$$

is continuous.

Exercise 10.5.4 Prove that if X has a countable basis for its topology, then so has A .

Exercise 10.5.5 Prove that if X is Hausdorff, then so is A .

Corollary 10.5.6 All subspaces of \mathbf{R}^n are Hausdorff, and have countable bases for their topologies.

Definition 10.5.7 If $A \subseteq X$ is a subspace, and $f: X \rightarrow Y$ is a map, then the composite

$$A \subseteq X \rightarrow Y$$

is called the *restriction of f to A* , and is written $f|_A$.

10.6 Quotient spaces

Definition 10.6.1 Let (X, \mathcal{U}) be a topological space, and consider an equivalence relation \sim on X . The *quotient space* with respect to the equivalence relation is the set X/\sim with the *quotient topology*. The quotient topology is defined as follows: Let

$$p: X \rightarrow X/\sim$$

be the projection sending an element to its equivalence class. A subset $V \subseteq X/\sim$ is open iff $p^{-1}(V) \subseteq X$ is open.

Exercise 10.6.2 Show that the subspace topology is a topology on X/\sim .

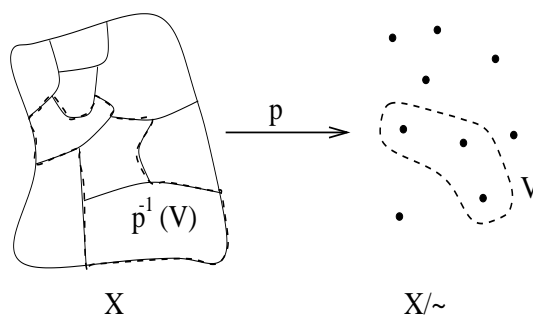

Exercise 10.6.3 Prove that a map from a quotient space $(X/\sim) \rightarrow Y$ is continuous iff the composite

$$X \rightarrow (X/\sim) \rightarrow Y$$

is continuous.

Exercise 10.6.4 The projection $\mathbf{R}^1 \rightarrow S^1$ given by $p \mapsto e^{ip}$ shows that we may view S^1 as the set of equivalence classes of real number under the equivalence $p \sim q$ if there is an integer n such that $p = q + 2\pi n$. Show that the quotient topology on S^1 is the same as the subspace topology you get by viewing S^1 as a subspace of \mathbf{R}^2 .

10.7 Compact spaces

Definition 10.7.1 A *compact space* is a space (X, \mathcal{U}) with the following property: in any set \mathcal{V} of open sets covering X (i.e. $\mathcal{V} \subseteq \mathcal{U}$ and $\bigcup_{V \in \mathcal{V}} V = X$) there is a finite subset that also covers X .

Exercise 10.7.2 If $f: X \rightarrow Y$ is a continuous map and X is compact, then $f(X)$ is compact.

We list without proof the results

Theorem 10.7.3 (*Heine–Borel*) *A subset of \mathbf{R}^n is compact iff it is closed and of finite size.*

Example 10.7.4 Hence the unit sphere $S^n = \{p \in \mathbf{R}^{n+1} \mid |p| = 1\}$ (with the subspace topology) is a compact space.

Exercise 10.7.5 The *real projective space* \mathbf{RP}^n is the quotient space S^n / \sim under the equivalence relation $p \sim -p$ on the unit sphere S^n . Prove that \mathbf{RP}^n is a compact Hausdorff space with a countable basis for its topology.

Theorem 10.7.6 *If X is a compact space, then a subset $C \subseteq X$ is closed if and only if $C \subseteq X$ is a compact subspace.*

Theorem 10.7.7 *If X is a Hausdorff space and $C \subseteq X$ is a compact subspace, then $C \subseteq X$ is closed.*

A very important corollary of the above results is the following:

Theorem 10.7.8 *If $f: C \rightarrow X$ is a continuous map where C is compact and X is Hausdorff, then f is a homeomorphism if and only if it is bijective.*

Exercise 10.7.9 Prove 10.7.8 using the results preceding it

Exercise 10.7.10 Prove in three or fewer lines the standard fact that a continuous function $f: [a, b] \rightarrow \mathbf{R}$ has a maximum value.

A last theorem sums up the some properties that are preserved under formation of quotient spaces (under favorable circumstances). It is not optimal, but will serve our needs. You can extract a proof from the more general statement given in [K, p. 148].

Theorem 10.7.11 *Let X be a compact space, and let \sim be an equivalence relation on X . Let $p: X \rightarrow X / \sim$ be the projection and assume that if $K \subseteq X$ is closed, then $p^{-1}p(K) \subseteq X$ is closed too.*

If X is Hausdorff, then so is X / \sim .

If X has a countable basis for its topology, then so has X / \sim .

10.8 Product spaces

Definition 10.8.1 If (X, \mathcal{U}) and (Y, \mathcal{V}) are two topological spaces, then their *product* $(X \times Y, \mathcal{U} \times \mathcal{V})$ is the set $X \times Y = \{(x, y) | x \in X, y \in Y\}$ with a basis for the topology given by products of open sets $U \times V$ with $U \in \mathcal{U}$ and $V \in \mathcal{V}$.

There are two projections $pr_X: X \times Y \rightarrow X$ and $pr_Y: X \times Y \rightarrow Y$. They are clearly continuous.

Exercise 10.8.2 A map $Z \rightarrow X \times Y$ is continuous iff both the composites with the projections

$$\begin{aligned} Z &\rightarrow X \times Y \rightarrow X, \text{ and} \\ Z &\rightarrow X \times Y \rightarrow Y \end{aligned}$$

are continuous.

Exercise 10.8.3 Show that the metric topology on \mathbf{R}^2 is the same as the product topology on $\mathbf{R}^1 \times \mathbf{R}^1$, and more generally, that the metric topology on \mathbf{R}^n is the same as the product topology on $\mathbf{R}^1 \times \cdots \times \mathbf{R}^1$.

Exercise 10.8.4 If X and Y have countable bases for their topologies, then so has $X \times Y$.

Exercise 10.8.5 If X and Y are Hausdorff, then so is $X \times Y$.

10.9 Connected spaces

Definition 10.9.1 A space X is *connected* if the only subsets that are both open and closed are the empty set and the set X itself.

Exercise 10.9.2 The natural generalization of the intermediate value theorem is “If $f: X \rightarrow Y$ is continuous and X connected, then $f(X)$ is connected”. Prove this.

Definition 10.9.3 Let (X, \mathcal{U}) and (Y, \mathcal{V}) be topological spaces. The *disjoint union* $X \amalg Y$ is the union of disjoint copies of X and Y , where an open set is a union of open sets in X and Y .

Exercise 10.9.4 Show that the disjoint union of two nonempty spaces X and Y is not connected.

Exercise 10.9.5 A map $X \amalg Y \rightarrow Z$ is continuous iff both the composites with the injections

$$\begin{aligned} X &\subseteq X \amalg Y \rightarrow Z \\ Y &\subseteq X \amalg Y \rightarrow Z \end{aligned}$$

are continuous.

10.10 Appendix 1: Equivalence relations

This appendix is used in 10.6 Quotient spaces.

Definition 10.10.1 Let X be a set. An *equivalence relation* on X is a subset E of the set $X \times X = \{(x_1, x_2) | x_1, x_2 \in X\}$ satisfying the following three conditions

$$\begin{array}{ll} \text{(reflexivity)} & (x, x) \in E \text{ for all } x \in X \\ \text{(symmetry)} & \text{If } (x_1, x_2) \in E \text{ then } (x_2, x_1) \in E \\ \text{(transitivity)} & \text{If } (x_1, x_2) \in E \text{ and } (x_2, x_3) \in E \text{ then } (x_1, x_3) \in E \end{array}$$

We often write $x_1 \sim x_2$ instead of $(x_1, x_2) \in E$.

Definition 10.10.2 Given an equivalence relation E on a set X we may for each $x \in X$ define the *equivalence class* of x to be the subset $[x] = \{y \in X | x \sim y\}$.

This divides X into a collection of nonempty, mutually disjoint subsets.

The set of equivalence classes is written X/\sim , and we have a surjective function

$$X \rightarrow X/\sim$$

sending $x \in X$ to its equivalence class $[x]$.

10.11 Appendix 2: Set theoretical stuff

Definition 10.11.1 Let $A \subseteq X$ be a subset. The *complement* of A in X is the subset

$$X \setminus A = \{x \in X | x \notin A\}$$

10.11.2 De Morgan's formulae

Let X be a set and $\{A_i\}_{i \in I}$ be a family of subsets. Then

$$\begin{aligned} X \setminus \bigcup_{i \in I} A_i &= \bigcap_{i \in I} (X \setminus A_i) \\ X \setminus \bigcap_{i \in I} A_i &= \bigcup_{i \in I} (X \setminus A_i) \end{aligned}$$

Apology: the use of the term *family* is just phony: to us a family is nothing but a set (so a "family of sets" is nothing but a set of sets).

Definition 10.11.3 Let $f: X \rightarrow Y$ be a function. We say that f is *injective* (or one-to-one) if $f(x_1) = f(x_2)$ implies that $x_1 = x_2$. We say that f is *surjective* (or onto) if for every $y \in Y$ there is an $x \in X$ such that $y = f(x)$. We say that f is *bijective* if it is both surjective and injective.

Definition 10.11.4 Let $A \subseteq X$ be a subset and $f: X \rightarrow Y$ a function. The *image* of A under f is the set

$$f(A) = \{y \in Y \mid \exists a \in A \text{ s.t. } y = f(a)\}$$

The subset $f(X) \subseteq Y$ is simply called the image of f .

If $B \subseteq Y$ is a subset, then the *inverse image* (or *preimage*) of B under f is the set

$$f^{-1}(B) = \{x \in X \mid f(x) \in B\}$$

The subset $f^{-1}(Y) \subseteq X$ is simply called the preimage of f .

Exercise 10.11.5 Prove that $f(f^{-1}(B)) \subseteq B$ and $A \subseteq f^{-1}(f(A))$.

Exercise 10.11.6 Prove that $f: X \rightarrow Y$ is surjective iff $f(X) = Y$ and injective iff for all $y \in Y$ $f^{-1}(\{y\})$ consists of a single element.

Exercise 10.11.7 Let $B_1, B_2 \subseteq Y$ and $f: X \rightarrow Y$ be a function. Prove that

$$f^{-1}(B_1 \cap B_2) = f^{-1}(B_1) \cap f^{-1}(B_2) \quad (10.1)$$

$$f^{-1}(B_1 \cup B_2) = f^{-1}(B_1) \cup f^{-1}(B_2) \quad (10.2)$$

$$f^{-1}(Y \setminus B_1) = X \setminus f^{-1}(B_1) \quad (10.3)$$

If in addition $A_1, A_2 \subseteq X$ then

$$f(A_1 \cup A_2) = f(A_1) \cup f(A_2) \quad (10.4)$$

$$f(A_1 \cap A_2) \subseteq f(A_1) \cap f(A_2) \quad (10.5)$$

$$Y \setminus f(A_1) \subseteq f(X \setminus A_1) \quad (10.6)$$

$$B_1 \cap f(A_1) = f(f^{-1}(B_1) \cap A_1) \quad (10.7)$$

Bibliography

- [B] Nicolas Bourbaki, Topologie générale
- [HR] Per Holm og Jon Reed, Topologi
- [K] John L. Kelley, General Topology
- [M] James R. Munkres, Topology

Chapter 11

Appendix: Facts from analysis

11.1 The chain rule

Definition 11.1.1 Let $f: U \rightarrow \mathbf{R}$ be a function where U is an open subset of \mathbf{R}^n containing $p = (p_1, \dots, p_n)$. The i th partial derivative of f at p is the number (if it exists)

$$D_i f(p) = D_i|_p(f) = \lim_{h \rightarrow 0} \frac{1}{h} (f(p + he_i) - f(p))$$

where e_i is the i th unit vector $e_i = (0, \dots, 0, 1, 0, \dots, 0)$ (with a 1 in the i th coordinate). We also write

$$D(f)(p) = D|_p(f) = (D_1(f)(p), \dots, D_n(f)(p))$$

Note 11.1.2 Several problems appear when the partial derivatives are not continuous functions. We will only be interested in smooth functions (\mathcal{C}^∞ : all higher order partial derivatives exist and are continuous), so we will ignore such difficulties.

Definition 11.1.3 If $f = (f_1, \dots, f_m): U \rightarrow \mathbf{R}^m$ is a function where U is an open subset of \mathbf{R}^n containing $p = (p_1, \dots, p_n)$, then the *Jacobian matrix* is the $m \times n$ -matrix

$$D(f)(p) = D|_p(f) = \begin{bmatrix} D(f_1)(p) \\ \vdots \\ D(f_m)(p) \end{bmatrix}$$

In particular, if $g = (g_1, \dots, g_n): (a, b) \rightarrow \mathbf{R}^m$ we write

$$g'(c) = D(g)(c) = \begin{bmatrix} g'_1(c) \\ \vdots \\ g'_n(c) \end{bmatrix}$$

Lemma 11.1.4 (*The chain rule*) Let $g: (a, b) \rightarrow U$ and $f: U \rightarrow \mathbf{R}$ be smooth functions where U is an open subset of \mathbf{R}^n and $c \in (a, b)$. Then

$$\begin{aligned}(fg)'(c) &= D(f)(g(c)) \cdot g'(c) \\ &= \sum_{j=1}^n D_j f(g(c)) \cdot g'_j(c)\end{aligned}$$

Proof: For a proof, see e.g. [SC], or any decent book on multi-variable calculus. ■

11.2 The inverse function theorem

Theorem 11.2.1 If $f: U_1 \rightarrow U_2$ is a differentiable function where $U_1, U_2 \subseteq \mathbf{R}^n$. Let $p \in U_1$ and assume the the Jacobi matrix $[Df(p)]$ is invertible in the point p . Then there exists a neighborhood around p on which f is smoothly invertible, i.e. there exists an open subset $U_0 \subseteq U_1$ containing p such that

$$f|_{U_0}: U_0 \rightarrow f(U_0)$$

is a diffeomorphism. The inverse has Jacobi matrix

$$[D(f^{-1})(f(x))] = [Df(x)]^{-1}$$

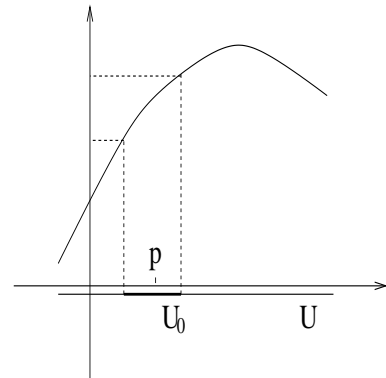

Proof: For a proof, see e.g. [SC] Theorem 2.11, or any decent book on multi-variable calculus. ■

11.3 Ordinary differential equations

We will have occasion to use the following theorem about the existence and uniqueness of solutions of first order ordinary differential equations.

Theorem 11.3.1 Let $f: U \rightarrow \mathbf{R}^n$ be a smooth map where $U \subseteq \mathbf{R}^n$ is an open subset and $p \in U$.

- (*Existence of solution*) There is a neighborhood $V \subseteq U$ of p , a neighborhood J of $0 \in \mathbf{R}$ and a smooth map

$$\Phi: J \times V \rightarrow U$$

such that

- $\Phi(0, q) = q$ for all $q \in V$ and
- $\frac{\partial}{\partial t}\Phi(t, q) = f(\Phi(t, q))$ for all $(t, q) \in J \times V$.

- (Uniqueness of solution) If γ_i are smooth curves in U satisfying $\gamma_1(0) = \gamma_2(0) = p$ and

$$\gamma'_i(t) = f(\gamma(t)), \quad i = 1, 2$$

then $\gamma_1 = \gamma_2$ where they both are defined.

Proof: The difficulty in proving these statements is taking care of the smoothness. For a nice proof giving just continuity see Spivak's book [S] chapter 5. For a real proof, see e.g. one of the analysis books of Lang. ■

Chapter 12

Hints or solutions to the exercises

Below you will find hints for all the exercises. Some are very short, and some are almost complete solutions. Ignore them if you can, but if you are stuck, take a peek and see if you can get some inspiration.

Chapter 2

Exercise 2.2.5

Draw a hexagon with identifications so that it represents a handle attached to a Möbius band. Try your luck at cutting and pasting this figure into the a (funny looking) hexagon with identifications so that it represents three Möbius bands glued together (remember that the cuts may cross your identified edges).

Exercise 2.2.6

See the first chapter of Spivak's book [S].

Exercise 2.2.7

Do an internet search to find the definition of the Euler number. To calculate the Euler number of surfaces you can simply use our flat representations as polygons, just remembering what points and edges really are identified.

Chapter 3

Exercise 3.2.7

Draw the lines in the picture in example 3.2.6 and use high school mathematics to show that the formulae are correct. Then invert these, and check the chart transformation formulae.

Exercise 3.2.10

Repeat the discussion for the real projective space, exchanging \mathbf{R} with \mathbf{C} everywhere.

Exercise 3.2.11

Transport the structure radially out from the unit circle (i.e. use the homeomorphism from the unit circle to the square gotten by blowing up a balloon in a square box in flatland). All charts can then be taken to be the charts on the circle composed with this homeomorphism.

Exercise 3.3.7

It is enough to show that all the “mixed chart transformations” (like $x^{0,0}(x^+)^{-1}$) are smooth. Why?

Exercise 3.3.8

Because saying that “ x is a diffeomorphism” is just a rephrasing of “ $x = x(id)^{-1}$ and $x^{-1} = (id)x^{-1}$ are smooth”. The charts in this structure are all diffeomorphisms $U \rightarrow U'$ where both U and U' are open subsets of \mathbf{R}^n .

Exercise 3.4.2

Use the identity chart on \mathbf{R} . The standard atlas on $S^1 \subseteq \mathbf{C}$ using projections is given simply by real and imaginary part. Hence the formulae you have to check are smooth are \sin and \cos . This we know! One comment on domains of definition: let $f: \mathbf{R} \rightarrow S^1$ be the map in question; if we use the chart $(x^{0,0}, U^{0,0})$, then $f^{-1}(U^{0,0})$ is the union of all the intervals on the form $(-\pi/2 + 2\pi k, \pi/2 + 2\pi k)$ when k varies over the integers. Hence the function to check in this case is the function from this union to $(-1, 1)$ sending θ to $\sin \theta$.

Exercise 3.4.3

First check that \tilde{g} is well defined. Check that it is smooth using the standard charts. To show that \tilde{g} is injective, show that $g(p) = g(q)$ implies that $p = \pm q$.

Exercise 3.4.4

Smoothness is a local question, and the projection $g: S^n \rightarrow \mathbf{RP}^n$ is a local diffeomorphism. More precisely, if $f: \mathbf{RP}^n \rightarrow M$ is a map, we have to show that for all charts (y, V) on M , the

composites $yf(x^k)^{-1}$ (defined on $U^k \cap f^{-1}(V)$) are smooth. But $x^k g(x^{k,0})^{-1}: D^n \rightarrow \mathbf{R}^n$ is a diffeomorphism (given by sending $p \in D^n$ to $\frac{1}{\sqrt{1-|p|^2}}p \in \mathbf{R}^n$), and so claiming that $yf(x^k)^{-1}$ is smooth is the same as claiming that $y(fg)(x^{k,0})^{-1} = yf(x^k)^{-1}x^k g(x^{k,0})^{-1}$ is smooth.

Exercise 3.4.11

Consider the map $S^1 \rightarrow \mathbf{RP}^1$ sending $e^{i\theta}$ to $[e^{i\theta/2}]$.

Exercise 3.4.13

Given a chart (x, U) on M , define a chart $(xf^{-1}, f(U))$ on N .

Exercise 3.4.18

To see this, note that given any p , there are open sets U_1 and V_1 with $p \in U_1$ and $i(p) \in V_1$ and $U_1 \cap V_1 = \emptyset$ (since M is Hausdorff). Let $U = U_1 \cap i(V_1)$. Then U and $i(U) = i(U_1) \cap V_1$ do not intersect. As a matter of fact M has a basis for its topology consisting of these kinds of open sets.

By shrinking even further, we may assume that U is a chart domain for a chart $x: U \rightarrow U'$ on M .

We see that $f|_U$ is open (it sends open sets to open sets, since the inverse image is the union of two open sets).

On U we see that f is injective, and so it induces a homeomorphism $f|_U: U \rightarrow f(U)$. We define the smooth structure on M/i by letting $x(f|_U)^{-1}$ be the charts for varying U . This is obviously a smooth structure, and f is a local diffeomorphism.

Exercise 3.4.19

Choose **any** chart $y: V \rightarrow V'$ with $p \in V$ in \mathcal{U} , choose a small open ball $B \subseteq V'$ around $y(p)$. There exists a diffeomorphism h of this ball with all of \mathbf{R}^n . Let $U = y^{-1}(B)$ and define x by setting $x(q) = hy(q) - hy(p)$.

Exercise 3.5.4

Use “polar coordinates”.

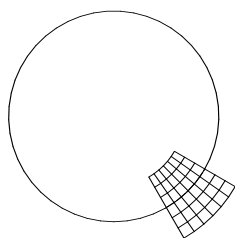
**Exercise 3.5.6**

Assume there is a chart $x: U \rightarrow U'$ with $(0, 0) \in U$, $x(0, 0) = (0, 0)$ and $x(K \cap U) = (\mathbf{R} \times 0) \cap U'$.

Then the composite (V is a sufficiently small neighborhood of 0)

$$V \xrightarrow{q \mapsto (q, 0)} U' \xrightarrow{x^{-1}} U$$

is smooth, and of the form $q \mapsto T(q) = (t(q), |t(q)|)$. But

$$T'(0) = \left(\lim_{h \rightarrow 0} \frac{t(h)}{h}, \lim_{h \rightarrow 0} \frac{|t(h)|}{h} \right),$$

and for this to exist, we must have $t'(0) = 0$.

On the other hand $x(p, |p|) = (s(p), 0)$, and we see that s and t are inverse functions. The directional derivative of $pr_1 x$ at $(0, 0)$ in the direction $(1, 1)$ is equal

$$\lim_{h \rightarrow 0^+} \frac{s(h)}{h}$$

but this limit does not exist since $t'(0) = 0$, and so x can't be smooth, contradiction.

Exercise 3.5.11

The subset $f(\mathbf{RP}^n) = \{[p, 0] \in \mathbf{RP}^{n+1}\}$ is a submanifold by using all but the last of the standard charts on \mathbf{RP}^{n+1} . Checking that $\mathbf{RP}^n \rightarrow f(\mathbf{RP}^n)$ is a diffeomorphism is now straightforward (the “ups, over and acrosses” correspond to the chart transformations in \mathbf{RP}^n).

Exercise 3.5.14

Assume $i_j: N_j \rightarrow M_j$ are inclusions of submanifolds — the diffeomorphism part of “imbedding” being the trivial case — and let $x_j: U_j \rightarrow U'_j$ be charts such that

$$x_j(U_j \cap N_j) = U'_j \cap (\mathbf{R}^{n_j} \times \{0\}) \subseteq \mathbf{R}^{m_j}$$

for $j = 1, 2$. To check whether f is smooth at $p \in N_1$ it is enough to assert that $x_2 f x_1^{-1}|_{x_1(V)} = x_2 g x_1^{-1}|_{x_1(V)}$ is smooth at p where $V = U_1 \cap N_1 \cap g^{-1}(U_2)$ which is done by checking the higher order partial derivatives in the relevant coordinates.

Exercise 3.6.2

Check that all chart transformations are smooth.

Exercise 3.6.5

Up over and across using appropriate charts on the product, reduces this to saying that the identity is smooth and that the inclusion of \mathbf{R}^m in $\mathbf{R}^m \times \mathbf{R}^n$ is an imbedding.

Exercise 3.6.6

The heart of the matter is that $\mathbf{R}^k \rightarrow \mathbf{R}^m \times \mathbf{R}^n$ is smooth if and only if both the composites $\mathbf{R}^k \rightarrow \mathbf{R}^m$ and $\mathbf{R}^k \rightarrow \mathbf{R}^n$ are smooth.

Exercise 3.6.7

Consider the map $(t, z) \mapsto e^t z$.

Exercise 3.6.8

Reduce to the case where f and g are inclusions of submanifolds. Then rearrange some coordinates to show that case.

Exercise 3.6.9

Use the preceding exercises.

Exercise 3.6.10

Remember that $\text{GL}_n(\mathbf{R})$ is an open subset of $M_n(\mathbf{R})$ and so this is in flatland 3.5.8). Multiplication of matrices is smooth since it is made out of addition and multiplication of real numbers.

Exercise 3.6.11

Use the fact that multiplication of complex numbers is smooth, plus 3.5.14).

Exercise 3.6.13

Check chart transformations.

Exercise 3.6.16

Using the “same” charts on both sides, this reduces to saying that the identity is smooth.

Exercise 3.6.17

A map from a disjoint union is smooth if and only if it is smooth on both summands since

smoothness is measured locally.

Chapter 4

Exercise 4.2.6

It depends neither on the representation of the tangent vector nor on the representation of the germ, because if $[\gamma] = [\nu]$ and $\bar{f} = \bar{g}$, then $(\phi f \gamma)'(0) = (\phi f \nu)'(0) = (\phi g \nu)'(0)$ (partially by definition).

Exercise 4.3.10

If $[\gamma] = [\nu]$, then $(\phi f \gamma)'(0) = (\phi f \nu)'(0)$.

Chapter 5

Exercise 5.2.3

See the next exercise. This refers the problem away, but the same reference helps you out on this one too!

Exercise 5.2.4

This exercise is solved in the smooth case in exercise 7.2.6. The only difference in the continuous case is that you delete every occurrence of “smooth” in the solution. In particular, the solution refers to a “smooth bump function $\phi: U_2 \rightarrow \mathbf{R}$ such that ϕ is one on (a, c) and zero on $U_2 \setminus (a, d)$ ”. This can in our case be chosen to be the (non smooth) map $\phi: U_2 \rightarrow \mathbf{R}$ given by

$$\phi(t) = \begin{cases} 1 & \text{if } t \leq c \\ \frac{d-t}{d-c} & \text{if } c \leq t \leq d \\ 0 & \text{if } t \geq d \end{cases}$$

Exercise 5.4.4

Use the chart domains on \mathbf{RP}^n from the manifold section:

$$U^k = \{[p] \in \mathbf{RP}^n \mid p_k \neq 0\}$$

and construct bundle charts $\pi^{-1}(U^k) \rightarrow U^k \times \mathbf{R}$ sending $([p], \lambda p)$ to $([p], \lambda p_k)$. The chart transformations then should look something like

$$([p], \lambda) \mapsto ([p], \lambda \frac{p_l}{p_k})$$

If the bundle were trivial, then $\eta_n \setminus \sigma_0(\mathbf{RP}^n)$ would be disconnected. In particular $([e_1], e_1)$ and $([e_1], -e_1)$ would be in different components. But $\gamma: [0, \pi] \rightarrow \eta_n \setminus \sigma_0(\mathbf{RP}^n)$ given by

$$\gamma(t) = ([\cos(t)e_1 + \sin(t)e_2], \cos(t)e_1 + \sin(t)e_2)$$

is a path connecting them.

Exercise 5.4.5

You may assume that $p = [0, \dots, 0, 1]$. Then any point $[x_0, \dots, x_{n-1}, x_n] \in X$ equals $[\frac{x}{|x|}, \frac{x_n}{|x|}]$ since $x = (x_0, \dots, x_{n-1})$ must be different from 0. Consider the map

$$X \rightarrow \eta_{n-1} \\ [x, x_n] \mapsto \left(\left[\frac{x}{|x|} \right], \frac{x_n x}{|x|^2} \right)$$

with inverse $([x], \lambda x) \mapsto [x, \lambda]$.

Exercise 5.5.8

View S^3 as the unit quaternions, and copy the argument for S^1 .

Exercise 5.5.9

Lie group is a smooth manifold equipped with a smooth associative multiplication, having a unit and possessing all inverses, so the proof for S^1 will work.

Exercise 5.5.13

If we set $z_j = x_j + iy_j$, $x = (x_0, \dots, x_n)$ and $y = (y_0, \dots, y_n)$, then $\sum_{i=0}^n z^2 = 1$ is equivalent to $x \cdot y = 0$ and $|x|^2 - |y|^2 = 1$. Use this to make an isomorphism to the bundle in example 5.5.10 sending the point (x, y) to $(p, v) = (\frac{x}{|x|}, y)$ (with inverse sending (p, v) to $(x, y) = (\sqrt{1 + |v|^2}p, v)$).

Exercise 5.5.16

Use the trivialization to pass the obvious solution on the product bundle to the tangent bundle.

Exercise 5.5.17

Any curve to a product is given uniquely by its projections to the factors.

Chapter 6

Exercise 6.2.3

Consider the smooth map

$$f: G \times G \rightarrow G \times G \\ (g, h) \mapsto (gh, h)$$

with inverse $(g, h) \mapsto (gh^{-1}, h)$. Use that, for a given $g \in G$, the map $G \rightarrow G$ sending h to gh is a diffeomorphism to conclude that f has maximal rank, and is a diffeomorphism. Then consider a composite

$$G \xrightarrow{g \mapsto (1, g)} G \times G \xrightarrow{f^{-1}} G \times G \xrightarrow{(g, h) \mapsto g} G$$

Exercise 6.3.3

Use the rank theorem. To prove that the rank is constant, first prove it for all points in $f(M)$ using the chain rule. See [BJ], Theorem 5.13. That $f(M) = \{p \in M \mid f(p) = p\}$ is closed in M follows since the complement is open: if $p \neq f(p)$ choose disjoint open sets U and V around p and $f(p)$. Then $U \cap f^{-1}(V)$ is an open set disjoint from $f(M)$ (since $U \cap f^{-1}(V) \subseteq U$ and $f(U \cap f^{-1}(V)) \subseteq V$) containing p .

Exercise 6.4.4

Prove that 1 is a regular value for the function $\mathbf{R}^{n+1} \rightarrow \mathbf{R}$ sending p to $|p|^2$.

Exercise 6.4.7

Observe that the function in question is

$$f(e^{i\theta}, e^{i\phi}) = \frac{1}{\sqrt{(3 - \cos \theta - \cos \phi)^2 + (\sin \theta + \sin \phi)^2}},$$

giving the claimed Jacobi matrix. Then solve the system of equations

$$3 \sin \theta - \cos \phi \sin \theta + \sin \phi \cos \theta = 0$$

$$3 \sin \phi - \cos \theta \sin \phi + \sin \theta \cos \phi = 0$$

Adding the two equations we get that $\sin \theta = \sin \phi$, but then the upper equation claims that $\sin \phi = 0$ or $3 - \cos \phi + \cos \theta = 0$. The latter is clearly impossible.

Exercise 6.4.9

Show that the map

$$SL_2(\mathbf{R}) \rightarrow (\mathbf{C} - \{0\}) \times \mathbf{R}$$

$$\begin{bmatrix} a & b \\ c & d \end{bmatrix} \mapsto (a + ic, ab + cd)$$

is a diffeomorphism, and that $S^1 \times \mathbf{R}$ is diffeomorphic to $\mathbf{C} - \{0\}$.

Exercise 6.4.10

Calculate the Jacobi matrix of the determinant function. With some choice of indices you should get

$$D_{ij}(\det)(A) = (-1)^{i+j} \det(A_{ij})$$

where A_{ij} is the matrix you get by deleting the i th row and the j th column. If the determinant is to be one, some of the entries in the Jacobi matrix then has got to be nonzero.

Exercise 6.4.12

By corollary 5.5.12 we identify $TO(n)$ with

$$E = \left\{ (g, A) \in O(n) \times M_n(\mathbf{R}) \left| \begin{array}{l} g = \gamma(0) \\ A = \gamma'(0) \\ \text{for some curve} \\ \gamma: (-\epsilon, \epsilon) \rightarrow O(n) \end{array} \right. \right\}$$

That $\gamma(s) \in O(n)$ is equivalent to saying that $I = \gamma(s)^t \gamma(s)$. This holds for all $s \in (-\epsilon, \epsilon)$, so we may derive this equation and get

$$0 = \frac{d}{ds} \Big|_{s=0} (\gamma(s)^t \gamma(s))$$

$$= \gamma'(0)^t \gamma(0) + \gamma(0)^t \gamma'(0)$$

$$= A^t g + g^t A$$

Exercise 6.4.14

Consider the chart $x: M_2(\mathbf{R}) \rightarrow \mathbf{R}^4$ given by

$$x \left(\begin{bmatrix} a & b \\ c & d \end{bmatrix} \right) = (a, b, a - d, b + c).$$

Exercise 6.4.15

Copy one of the proofs for the orthogonal group, replacing the symmetric matrices with Hermitian matrices.

Exercise 6.4.16

The space of orthogonal matrices is compact since it is a closed subset of $[-1, 1]^{n^2}$. It has at least two components since the sets of matrices with determinant 1 is closed, as is the complement: the set with determinant -1 .

Each of these are connected since you can get from any rotation to the identity through a path of rotations. One way to see this is to use the fact from linear algebra which says that any element $A \in SO(n)$ can be written in the form $A = BTB^{-1}$ where B and T are orthogonal, and furthermore T is a block diagonal matrix where the block matrices are either a single 1 on the diagonal, or of the form

$$T(\theta_k) = \begin{bmatrix} \cos \theta_k & -\sin \theta_k \\ \sin \theta_k & \cos \theta_k \end{bmatrix}.$$

So we see that replacing all the θ_k 's by $s\theta_k$ and letting s vary from 1 to 0 we get a path from A to the identity matrix.

Exercise 6.4.19

Consider a k -frame as a matrix A with the property that $A^t A = I$, and proceed as for the orthogonal group.

Exercise 6.4.21

Either just solve the equation or consider the map

$$f: P_3 \rightarrow P_2$$

sending $y \in P_3$ to $f(y) = (y'')^2 - y' + y(0) + xy'(0) \in P_2$. If you calculate the Jacobian in

obvious coordinates you get that

$$Df(a_0 + a_1x + a_2x^2 + a_3x^3) = \begin{bmatrix} 1 & -1 & 8a_2 & 0 \\ 0 & 1 & 24a_3 - 2 & 24a_2 \\ 0 & 0 & 0 & 72a_3 - 3 \end{bmatrix}$$

The only way this matrix can be singular is if $a_3 = 1/24$, but the top coefficient in $f(a_0 + a_1x + a_2x^2 + a_3x^3)$ is $36a_3^2 - 3a_3$ which won't be zero if $a_3 = 1/24$. By the way, if I did not calculate something wrong, the solution is the disjoint union of two manifolds $M_1 = \{2t(1-2t) + 2tx + tx^2 | t \in \mathbf{R}\}$ and $M_2 = \{-24t^2 + tx^2 + x^3/12 | t \in \mathbf{R}\}$, both diffeomorphic to \mathbf{R} .

Exercise 6.4.22

Yeah.

Exercise 6.4.23

Consider the function

$$f: \mathbf{R}^n \rightarrow \mathbf{R}$$

given by

$$f(p) = p^t A p.$$

The Jacobi matrix is easily calculated, and using that A is symmetric we get that $Df(p) = 2p^t A$. But given that $f(p) = b$ we get that $Df(p) \cdot p = p^t A p = b$, and so $Df(p) \neq 0$ if $b \neq 0$. Hence all values but $b = 0$ are regular. The value $b = 0$ is critical since $0 \in f^{-1}(0)$ and $Df(0) = 0$.

Exercise 6.4.24

For the first case, you may assume that the regular value in question is 0. Since zero is a regular value, the derivative in the "fiber direction" has got to be nonzero, and so the values of f are positive on one side of the zero section... but there IS no "one side" of the zero section! This takes

care of all one-dimensional cases, and higher dimensional examples are excluded since the map won't be regular if the dimension increases.

Exercise 6.4.25

You don't actually need theorem 6.4.3 to prove this since you can isolate T in this equation, and show directly that you get a submanifold diffeomorphic to \mathbf{R}^2 , but still, as an exercise you should do it by using theorem 6.4.3.

Exercise 6.4.26

Code a flexible n -gon by means of a vector $x^0 \in \mathbf{R}^2$ giving the coordinates of the first point, and vectors $x^i \in S^1$ going from point i to point $i+1$ for $i = 1, \dots, n-1$ (the vector from point n to point 1 is not needed, since it will be given by the requirement that the curve is closed). The set $\mathbf{R}^2 \times (S^1)^{n-1}$ will give a flexible n -gon, except, that the last line may not be of length 1. To ensure this, look at the map

$$f: \mathbf{R}^k \times (S^{k-1})^{n-1} \rightarrow \mathbf{R}$$

$$(x^0, (x^1, \dots, x^{n-1})) \mapsto \left| \sum_{i=1}^{n-1} x^i \right|^2$$

and show that 1 is a regular value. If you let $x^j = e^{i\phi_j}$ and $x = (x^0, (x^1, \dots, x^{n-1}))$, you get that

$$D_j f(x) = D_j \left(\left(\sum_{k=1}^{n-1} e^{i\phi_k} \right) \left(\sum_{k=1}^{n-1} e^{-i\phi_k} \right) \right)$$

$$= ie^{i\phi_j} \left(\sum_{k=1}^{n-1} e^{-i\phi_k} \right) + \left(\sum_{k=1}^{n-1} e^{i\phi_k} \right) (-ie^{-i\phi_j})$$

$$= -2Im \left(e^{i\phi_j} \left(\sum_{k=1}^{n-1} e^{-i\phi_k} \right) \right)$$

That the rank is not 1 is equivalent to $D_j f(x) = 0$ for all j . Analyzing this, we get that x_1, \dots, x_{n-1} must then all be parallel. But this

is impossible if n is odd and $\left| \sum_{i=1}^{n-1} x^i \right|^2 = 1$. (Note that this argument fails for n even. If $n = 4$ $LF_{4,2}$ is not a manifold: given x^1 and x^2 there are two choices for x^3 and x^4 : (either $x^3 = -x^2$ and $x^4 = -x^1$ or $x^3 = -x^1$ and $x^4 = -x^2$), but when $x^1 = x^2$ we get a crossing of these two choices).

Exercise 6.4.27

The non-self-intersecting flexible n -gons form an open subset.

Exercise 6.5.2

It is clearly injective, and an immersion since it has rank 1 everywhere. It is not an imbedding since $\mathbf{R} \amalg \mathbf{R}$ is disconnected, whereas the image is connected.

Exercise 6.5.3

It is clearly injective, and immersion since it has rank 1 everywhere. It is not an imbedding since an open set containing a point z with $|z| = 1$ in the image must contain elements in the image of the first summand.

Exercise 6.5.6

If a/b is irrational then the image of $f_{a,b}$ is dense: that is any open set on $S^1 \times S^1$ intersects the image of $f_{a,b}$.

Exercise 6.5.7

Show that it is an injective immersion homeomorphic to its image. The last property follows since both the maps in

$$M \longrightarrow i(M) \longrightarrow ji(M)$$

are continuous and bijective and the composite is a homeomorphism.

Chapter 7

Exercise 7.2.1

The only problem is in the origin. If you calculate

$$\begin{aligned} \lim_{t \rightarrow 0^+} \frac{1}{t}(\lambda(t) - \lambda(0)) &= \lim_{t \rightarrow 0^+} \frac{e^{-1/t^2}}{t} \\ &= \lim_{s \rightarrow \infty} se^{-s^2} = 0 \end{aligned}$$

you see that λ is once differentiable, and it continues this way proving that λ is smooth.

Exercise 7.2.3

Let $\phi: U_\phi \rightarrow \mathbf{R}$ be a representative for $\bar{\phi}$, and let (x, U) be any chart around p such that $x(p) = 0$. Choose an $\epsilon > 0$ such that $x(U \cap U_\phi)$ contains the open ball of radius ϵ . Then the germ represented by ϕ is equal to the germ represented by the map defined on all of M given by

$$q \mapsto \begin{cases} \gamma_{(\epsilon/3, \epsilon/3)}(x(q))\phi(q) & \text{for } q \in U \cap U_\phi \\ 0 & \text{otherwise.} \end{cases}$$

Exercise 7.2.4

You can extend any chart to a function defined on the entire manifold.

Exercise 7.2.5

Smoothen up the proof you gave for the same question in the vector bundle chapter, or use parts of the solution of exercise 7.2.6.

Exercise 7.2.6

Let $\pi: E \rightarrow S^1$ be a one-dimensional smooth vector bundle (one-dimensional smooth vector bundles are frequently called *line bundles*). Since S^1 is compact we may choose a finite bundle atlas, and we may remove superfluous bundle charts, so that no domain is included in another. We may also assume that all chart domains are connected. If there is just one bundle chart, we are finished, otherwise we proceed as follows. If we start at some point, we may order the charts, so that they intersect in a nonempty interval (or a disjoint union of two intervals if there are exactly two charts). Consider two consecutive charts (h_1, U_1) and (h_2, U_2) and let (a, b) be (one of the components of) their intersection. The transition function

$$h_{12}: (a, b) \rightarrow \mathbf{R} \setminus \{0\} \cong GL_1(\mathbf{R})$$

must take either just negative or just positive values. Multiplying h_2 by the sign of h_{12} we get a situation where we may assume that h_{12} always is positive. Let $a < c < d < b$, and choose a smooth bump function $\phi: U_2 \rightarrow \mathbf{R}$ such that ϕ is one on (a, c) and zero on $U_2 \setminus (a, d)$. Define a new chart (h'_2, U_2) by letting

$$h'_2(t) = \left(\frac{\phi(t)}{h_{12}(t)} + 1 - \phi(t) \right) h_2(t)$$

(since $h_{12}(t) > 0$, the factor by which we multiply $h_2(t)$ is never zero). On (a, c) the transition function is now constantly equal to one, so if there were more than two charts we could merge our two charts into a chart with chart domain $U_1 \cup U_2$.

So we may assume that there are just two charts. Then we may proceed as above on one of the components of the intersection between the two charts, and get the transition function to be the identity. But then we would not be left with the option of multiplying with the sign of the transition function on the other component. However, by the same method, we could only make it plus

or minus one, which exactly correspond to the trivial bundle and the canonical line bundle.

Just the same argument shows that there are exactly two isomorphism types of n -dimensional smooth vector bundles over S^1 (using that $GL_n(\mathbf{R})$ has exactly two components). The same argument also gives the corresponding topological fact.

Chapter 8

Exercise 8.1.4

As an example, consider the open subset $U^{0,0} = \{e^{i\theta} \in S^1 \mid \cos \theta > 0\}$. The bundle chart $h: U^{0,0} \times \mathbf{C} \rightarrow U^{0,0} \times \mathbf{C}$ given by sending $(e^{i\theta}, z)$ to $(e^{i\theta}, e^{-i\theta/2}z)$. Then $h((U^{0,0} \times \mathbf{C}) \cap \eta_1) = U^{0,0} \times \mathbf{R}$. Continue this way all around the circle. The idea is the same for higher dimensions: locally you can pick the first coordinate to be on the line $[p]$.

Exercise 8.1.11

Let $X_k = \{p \in X \mid rk_p f = k\}$. We want to show that X_k is both open and closed, and hence either empty or all of X since X is connected.

Let $P = \{A \in M_m(\mathbf{R}) \mid A = A^2\}$, then $P_k = \{A \in P \mid rk(A) = k\} \subseteq P$ is open. To see this, write P_k as the intersection of P with the two open sets

$$\{A \in M_n(\mathbf{R}) \mid rk A \geq k\}$$

and

$$\left\{ A \in M_n(\mathbf{R}) \left| \begin{array}{l} A \text{ has less than} \\ \text{or equal to } k \\ \text{linearly independent} \\ \text{eigenvectors with} \\ \text{eigenvalue } 1 \end{array} \right. \right\}.$$

But, given a bundle chart (h, U) , then the map

$$U \xrightarrow{p \mapsto h_p f_p h_p^{-1}} P$$

is continuous, and hence $U \cap X_k$ is open in U . Varying (h, U) we get that X_k is open, and hence also closed since $X_k = X \setminus \bigcup_{i \neq k} X_i$.

Exercise 8.1.12

Use exercise 8.1.11 to show that the bundle map $\frac{1}{2}(id_E - f)$ has constant rank (here we use that the set of bundle morphisms is in an obvious way a vector space).

Exercise 8.2.4

$$A \times_X E = \pi^{-1}(A).$$

Exercise 8.2.5

This is not as complex as it seems. For instance, the map $\tilde{E} \rightarrow f^*E = X' \times_X E$ must send e to $(\tilde{\pi}(e), g(e))$ for the diagrams to commute.

Exercise 8.2.6

If $h: E \rightarrow X \times \mathbf{R}^n$ is a trivialization, then the map $f^*E = Y \times_X E \rightarrow Y \times_X (X \times \mathbf{R}^n)$ induced by h is a trivialization, since $Y \times_X (X \times \mathbf{R}^n) \rightarrow Y \times \mathbf{R}^n$ sending $(y, (x, v))$ to (y, v) is a homeomorphism.

Exercise 8.2.7

$$X \times_Y (Y \times_Z E) \cong X \times_Z E.$$

Exercise 8.3.2

The transition functions will be of the type $U \mapsto GL_{n_1+n_2}(\mathbf{R})$, which sends $p \in U$ to the block matrix

$$\begin{bmatrix} (h_1)_p (g_1)_p^{-1} & 0 \\ 0 & (h_2)_p (g_2)_p^{-1} \end{bmatrix}$$

which is smooth if each of the blocks are smooth. Similarly for the morphisms.

Exercise 8.3.4

Use the map $\epsilon \rightarrow S^n \times \mathbf{R}$ sending $(p, \lambda p)$ to (p, λ) .

Exercise 8.3.6

Consider $TS^n \oplus \epsilon$, where ϵ is gotten from exercise 8.3.4. Construct a trivialization $TS^n \oplus \epsilon \rightarrow S^n \times \mathbf{R}^{n+1}$.

Exercise 8.3.7

$$\begin{aligned} \epsilon_1 \oplus \epsilon_2 &\xrightarrow[\cong]{h_1 \oplus h_2} X \times (\mathbf{R}^{n_1} \oplus \mathbf{R}^{n_2}) \\ (E_1 \oplus E_2) \oplus (\epsilon_1 \oplus \epsilon_2) &\cong (E_1 \oplus \epsilon_1) \oplus (E_2 \oplus \epsilon_2) \end{aligned}$$

Exercise 8.3.8

Given f_1 and f_2 , let $f: E_1 \oplus E_2 \rightarrow E_3$ be given by sending $(v, w) \in \pi_1^{-1}(p) \oplus \pi_2^{-1}(p)$ to $f_1(v) + f_2(w) \in \pi_3^{-1}(p)$. Given f let $f_1(v) = f(v, 0)$ and $f_2(w) = f(0, w)$.

Exercise 8.4.4

Send the bundle morphism f to the section which to any $p \in X$ assigns the linear map $f_p: E_p \rightarrow E'_p$.

Exercise 8.4.6

Let $F \subseteq E$ be a k -dimensional subbundle of the n -dimensional vector bundle $\pi: E \rightarrow X$. Define as a set

$$E/F = \coprod_{p \in X} E_p/F_p$$

with the obvious projection $\bar{\pi}: E/F \rightarrow X$. The bundle atlas is given as follows. For $p \in X$ choose bundle chart $h: \pi^{-1}(U) \rightarrow U \times \mathbf{R}^n$ such that $h(\pi^{-1}(U) \cap F) = U \times \mathbf{R}^k \times \{0\}$. On each fiber this gives a linear map on the quotient $\bar{h}_p: E_p/F_p \rightarrow \mathbf{R}^n/\mathbf{R}^k \times \{0\}$ via the formula $\bar{h}_p(\bar{v}) = \overline{h_p(v)}$ as in 2. This gives a function

$$\begin{aligned} \bar{h}: (\bar{\pi})^{-1}(U) &= \coprod_{p \in U} E_p/F_p \\ &\rightarrow \coprod_{p \in U} \mathbf{R}^n/\mathbf{R}^k \times \{0\} \\ &\cong U \times \mathbf{R}^n/\mathbf{R}^k \times \{0\} \\ &\cong U \times \mathbf{R}^{n-k}. \end{aligned}$$

You then have to check that the transition functions $p \mapsto \bar{g}_p \bar{h}_p^{-1} = g_p h_p^{-1}$ are continuous (or smooth).

As for the map of quotient bundles, this follows similarly: define it on each fiber and check continuity of “up, over and down”.

Exercise 8.4.7

$Alt^k(E) = \coprod_{p \in X} Alt^k E_p$ and so on.

Exercise 8.4.8

The transition functions on $L \rightarrow M$ are maps into nonzero real numbers, and on the tensor product this number is squared, and so all transition functions on $L \otimes L \rightarrow M$ map into positive real numbers. Use partition of unity to glue these together and scale them to be the constantly 1.

Exercise 8.6.5

Note that the map in question induces a linear map on every fiber which is an isomorphism, and hence by lemma 5.3.12 the map is an isomorphism of bundles.

Exercise 8.6.8

Use lemma 8.6.2 and exercise 8.6.5 to show that the bundle in question is isomorphic to $(T\mathbf{R}^n)|_M \rightarrow M$.

Exercise 8.6.9

You have done this exercise before!

Exercise 8.6.10

Prove that the diagonal $M \rightarrow M \times M$ is an imbedding by proving that it is an immersion inducing a homeomorphism onto its image. The tangent space of the diagonal at (p, p) is exactly the diagonal of $T_{(p,p)}(M \times M) \cong T_p M \times T_p M$. For any vector space V , the quotient space $V \times V/\text{diagonal}$ is canonically isomorphic to V via the map given by sending $(v_1, v_2) \in V \times V$ to $v_1 - v_2 \in V$.

Exercise 8.7.6

Show that the map

$$f \times g: M \times L \rightarrow N \times N$$

is transverse to the diagonal (which is discussed in exercise 8.6.10), and that the inverse image of the diagonal is exactly $M \times_N L$.

Exercise 8.8.1

The conditions you need are exactly the ones fulfilled by the elementary definition of the determinant: check your freshman introduction.

Exercise 8.9.1

Check out e.g. [MS] page 57.

Exercise 8.9.2

Check out e.g. [MS] page 59.

Exercise 8.9.4

Check out e.g. [MS] page 60.

Chapter 9

Exercise 9.1.4

Check the two defining properties of a flow. As an aside: this flow could be thought of as the flow $\mathbf{R} \times \mathbf{C} \rightarrow \mathbf{C}$ sending (t, z) to $e^{-z-t/2}$, which obviously satisfies the two conditions.

Exercise 9.1.19

Consider one of the “bad” injective immersions that fail to be imbeddings, and force a discontinuity on the velocity field.

Exercise 9.2.3

Consider a bump function ϕ on the sphere which is 1 near the North pole and 0 near the South pole. Consider the vector field $Z = \phi \vec{\Phi} + (1 - \phi) \vec{\Psi}$. Near the North pole $Z = \vec{\Phi}$ and near the South pole $Z = \vec{\Psi}$, and so the flow associated with Z has the desired properties.

Exercise 9.2.4

The vector field associated with the flow

$$\Phi: \mathbf{R} \times (S^1 \times S^1) \rightarrow (S^1 \times S^1)$$

given by $\Phi(t, (z_1, z_2)) = (e^{iat} z_1, e^{ibt} z_2)$ exhibits the desired phenomena when varying the real numbers a and b .

Exercise 9.2.5

All we have to show is that X is the velocity field of Φ . Under the diffeomorphism

$$\begin{aligned} TO(n) &\rightarrow E \\ [\gamma] &\rightarrow (\gamma(0), \gamma'(0)) \end{aligned}$$

this corresponds to the observation that

$$\left. \frac{\partial}{\partial s} \right|_{s=0} \Phi(s, g) = gA.$$

Exercise 9.5.8

Concerning the map $\ell: S^1 \rightarrow \mathbf{CP}^1$: note that it maps into a chart domain on which lemma tells us that the projection is trivial.

Exercise 9.4.5

Do a variation of example 9.3.3.

Exercise 9.5.9

Write \mathbf{R} as a union of intervals J_j so that for each j , $\gamma(U_j)$ is contained within one of the open subsets of M so that the fibration trivializes. On each of these intervals the curve lifts, and you may glue the liftings using bump functions.

Exercise 9.6.3

There is no hint beyond: use the definitions!

Exercise 9.6.4

Use the preceding exercise: notice that $T\pi_M\xi = \pi_{TM}\xi$ is necessary for things to make sense since $\tilde{\gamma}$ had two repeated coordinates.

Exercise 9.6.8

The conditions the sections have to satisfy are convex, just as in the proof of existence of Riemannian structures.

Exercise 9.6.9

The thing to check is that \mathcal{T} is an open neighborhood of the zero section.

Chapter 10**Exercise 10.1.5**

Consider the union of the closed intervals $[1/n, 1]$ for $n \geq 1$

Exercise 10.1.7

Consider the set of all open subsets of X contained in U . Its union is open.

Exercise 10.1.9

By the union axiom for open sets, $\text{int } A$ is open and contains all open subsets of A .

Exercise 10.1.10

The intersection of two open balls is the union of all open balls contained in the intersection.

Exercise 10.1.11

All open intervals are open balls!

Exercise 10.2.2

Hint one way: the “existence of the δ ” assures you that every point in the inverse image has a small interval around it inside the inverse image of the ϵ ball.

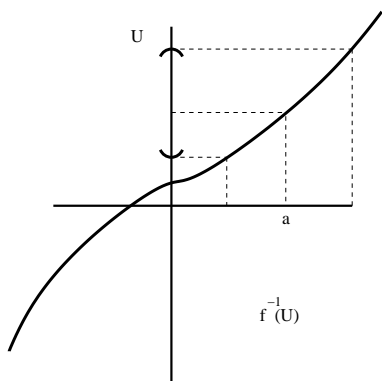
**Exercise 10.2.3**

$$f^{-1}(g^{-1}(U)) = (gf)^{-1}(U).$$

Exercise 10.2.6

Use first year calculus.

Exercise 10.3.3

Can you prove that the set containing only the intervals (a, b) when a and b varies over the rational numbers is a basis for the usual topology on the real numbers?

Exercise 10.3.4

Show that given a point and an openball containing the point there is a “rational” ball in between.

Exercise 10.3.5

Use note 10.3.2.

Exercise 10.3.6

$$f^{-1}(\bigcup_{\alpha} V_{\alpha}) = \bigcup_{\alpha} f^{-1}(V_{\alpha}).$$

Exercise 10.5.2

Use that $(\bigcup_{\alpha} U_{\alpha}) \cap A = \bigcup_{\alpha} (U_{\alpha} \cap A)$ and $(\bigcap_{\alpha} U_{\alpha}) \cap A = \bigcap_{\alpha} (U_{\alpha} \cap A)$.

Exercise 10.5.3

Use 10.2.3 one way, and that if $f^{-1}(U \cap A) = f^{-1}(U)$ the other.

Exercise 10.5.4

The intersections of A with the basis elements of the topology on X will form a basis for the subspace topology on A .

Exercise 10.5.5

Separate points in A by means of disjoint neighborhoods in X , and intersect with A .

Exercise 10.6.2

Inverse image commutes with union and intersection.

Exercise 10.6.3

Use 10.2.3 one way, and the characterization of open sets in X/\sim for the other.

Exercise 10.6.4

Show that open sets in one topology are open in the other.

Exercise 10.7.2

Cover $f(X) \subseteq Y$ by open sets i.e. by sets of the form $V \cap f(X)$ where V is open in Y . Since $f^{-1}(V \cap f(X)) = f^{-1}(V)$ is open in X , this gives a covering of X . Choose a finite subcover, and select the associated V 's to cover $f(X)$.

Exercise 10.7.5

The real projective space is compact by 10.7.2. The rest of the claims follows by 10.7.11, but you can give a direct proof by following the outline below.

For $p \in S^n$ let $[p]$ be the equivalence class of p considered as an element of \mathbf{RP}^n . Let $[p]$ and $[q]$ be two different points. Choose an ϵ such that ϵ is less than both $|p - q|/2$ and $|p + q|/2$. Then the ϵ balls around p and $-p$ do not intersect the ϵ balls around q and $-q$, and their image define disjoint open sets separating $[p]$ and $[q]$.

Notice that the projection $p: S^n \rightarrow \mathbf{RP}^n$ sends open sets to open sets, and that if $V \subseteq \mathbf{RP}^n$, then $V = pp^{-1}(V)$. This implies that the countable basis on S^n inherited as a subspace of \mathbf{R}^{n+1} maps to a countable basis for the topology on \mathbf{RP}^n .

Exercise 10.7.9

You must show that if $K \subseteq C$ is closed, then $(f^{-1})^{-1}(K) = f(K)$ is closed.

Exercise 10.7.10

Use Heine-Borel 10.7.3 and exercise 10.7.2.

Exercise 10.8.2

One way follows by 10.2.3. For the other, observe that by exercise 10.3.6 it is enough to show that if $U \subseteq X$ and $V \subseteq Y$ are open sets, then the inverse image of $U \times V$ is open in Z .

Exercise 10.8.3

Show that a square around any point contains a circle around the point and vice versa.

Exercise 10.8.4

If \mathcal{B} is a basis for the topology on X and \mathcal{C} is a basis for the topology on Y , then

$$\{U \times V \mid U \in \mathcal{B}, V \in \mathcal{C}\}$$

is a basis for $X \times Y$.

Exercise 10.8.5

If $(p_1, q_1) \neq (p_2, q_2) \in X \times Y$, then either $p_1 \neq p_2$ or $q_1 \neq q_2$. Assume the former, and let U_1 and U_2 be two open sets in X separating p_1 and p_2 . Then $U_1 \times Y$ and $U_2 \times Y$ are...

Exercise 10.9.2

The inverse image of a set that is both open and closed is both open and closed.

Exercise 10.9.4

Both X and Y are open sets.

Exercise 10.9.5

One way follows by 10.2.3. The other follows since an open subset of $X \coprod Y$ is the (disjoint) union of an open subset of X with an open subset of Y .

Exercise 10.11.5

If $p \in f(f^{-1}(B))$ then $p = f(q)$ for a $q \in f^{-1}(B)$. But that $q \in f^{-1}(B)$ means simply that $f(q) \in B$!

Exercise 10.11.6

These are just rewritings.

Exercise 10.11.7

We have that $p \in f^{-1}(B_1 \cap B_2)$ iff $f(p) \in B_1 \cap B_2$ iff $f(p)$ is in **both** B_1 and B_2 iff p is in **both** $f^{-1}(B_1)$ and $f^{-1}(B_2)$ iff $p \in f^{-1}(B_1) \cap f^{-1}(B_2)$. The others are equally fun.

Bibliography

- [BJ] Bröcker, Th. and Jänich, Introduction to differential topology. Translated from the German by C. B. Thomas and M. J. Thomas. Cambridge University Press, Cambridge-New York, 1982. vii+160 pp. ISBN: 0-521-24135-9; 0-521-28470-8 58-01 (57Rxx)
- [H] Hirsch, Morris W. Differential topology. Corrected reprint of the 1976 original. Graduate Texts in Mathematics, 33. Springer-Verlag, New York, 1994. x+222 pp. ISBN: 0-387-90148-5 57-01 (58-01)
- [M] Milnor, John W. Topology from the differential viewpoint. Based on notes by David W. Weaver. Revised reprint of the 1965 original. Princeton Landmarks in Mathematics. Princeton University Press, Princeton, NJ, 1997. xii+64 pp. ISBN: 0-691-04833-9 57Rxx
- [MS] Milnor, John W. and Stasheff, James D. Characteristic classes. . Annals of Mathematics Studies, No. 76. Princeton University Press, Princeton, N. J.; University of Tokyo Press, Tokyo, 1974. vii+331 pp. 57-01 (55-02 55F40 57D20)
- [S] Spivak, Micheal, A comprehensive introduction th differential geometry. Vol. I. Second edition. Publish or Perish, Inc., Wilmington, Del., 1979. xiv+668 pp. ISBN: 0-914098-83-7 53-01
- [SC] Spivak, Micheal, Calculus on manifolds. A modern approach to classical theorems of advanced calculus. W. A. Benjamin, Inc., New York-Amsterdam 1965 xii+144 pp. 26.20 (57.00)

Index

- $C^\infty(M)$, 33
- $C^\infty(M, N)$, 33
- D , $_pM$ 52
- E^n : the open n -disk, 22
- G_n^k , 86
- $L: \mathbf{R} \times \mathbf{R} \rightarrow \mathbf{R}$, 125
- $M_n\mathbf{R}$, 37
- $M_{m \times n}\mathbf{R}$, 37
- $M_{m \times n}^r\mathbf{R}$, 37
- $O(n)$, 83
- $SL_n(\mathbf{R})$, 83
- $SO(n)$, 86
- S^n : the n -sphere, 22
- T_pM , 47
- $T_pM \cong D$, $_pM$ 55
- $T_p f$, 49
- $U(n)$, 86
- V_n^k , 86
- $[\gamma] = [\bar{\gamma}]$, 47
- \approx , 47
- \bar{f} , germ represented by f , 44
- \mathcal{C}^∞ =smooth, 30
- \mathcal{D} , 28
- $GL_n(\mathbf{R})$, 37
- $\xi(M, p)$, 46
- $f^*: \xi(f(p)) \rightarrow \xi(p)$, 46
- k -frame, 86
- pr_i , 46
- $rk_p f$, 75
- $supp(f)$, 93

- alternating forms, 111
- atlas, 21
 - bundle, 60
 - good, 97
 - maximal, 29
 - smooth bundle, 63
- bad taste, 60
- base space, 60
- basis for the topology, 148
- bijective, 155
- Borromean rings, 41
- bump function, 95
- bundle
 - atlas, 60
 - smooth, 63
 - chart, 60
 - chart transformation, 62
 - morphism, 61
 - smooth, 65
- canonical n -plane bundle, 121
- canonical line bundle, 60
- chain rule, 49
- chain rule, the, 160
- chart, 21
 - domain, 21
 - transformation, 24
- closed set, 146
- closure, 146
- compact space, 150
- complement, 146, 154
- complex projective space, \mathbf{CP}^n , 28
- composition of germs, 45
- connected space, 152
- connected sum, 16
- constant rank, 103
- continuous
 - map, 147
- coordinate functions
 - standard, 46

- countable basis, 148
- critical, 76
- De Morgan's formulae, 154
- derivation, 52
- determinant function, 119
- diffeomorphic, 32
- diffeomorphism, 25, 32
- differentiable manifold, 30
- differentiable map, 31
- differential=smooth, 30
- disjoint union, 40, 152
- dual space, 110
- Ehresmann's fibration theorem, 140
- Ehresmann's fibration theorem, 137
- embedding=imbedding, 38
- equivalence
 - class, 154
 - relation, 154
- existence of maxima, 151
- exponential map, 143
- exterior power, 111
- family, 154
- fiber, 60
- fiber product, 105, 119
- fixed point free involution, 34
- flow
 - global, 124
 - local, 133
 - maximal local, 134
- flow line, 126, 134
- function germ, 46
- fusion reactor, 73
- generalized Gauss map, 122
- generate (a topology), 148
- genus, 16
- geodesic, 142
- germ, 44
- good atlas, 97
- Grassmann manifold, 86, 121
- handle, 16
- Hausdorff space, 149
- Heine–Borel's theorem, 151
- hom-space, 110
- homeomorphic, 147
- homeomorphism, 147
- Hopf fibration, 140
- image, 155
 - of bundle morphism, 105
 - of map of vector spaces, 104
- imbedding, 38
- immersion, 81
- induced bundle, 105
- injective, 155
- Integrability theorem, 130, 134
- interior, 146
- intermediate value theorem, 152
- inverse function theorem, 77, 160
- inverse image, 155
- isomorphism of smooth vector bundles, 65
- Jacobi matrix, 54
- Jacobian matrix, 159
- kernel
 - of bundle morphism, 105
 - of map of vector spaces, 104
- labelled flexible n -gons, 87
- Leibnitz rule, 52
- Lie Group
 - S^1 is one, 40
- Lie group
 - $O(n)$, 85
 - $SL_n(\mathbf{R})$, 85
 - $U(n)$, 86
 - $GL_n(\mathbf{R})$ is one, 40
- line bundle, 173
- line bundle, 63, 96
- local diffeomorphism, 34
- local flow, 133
- local trivialization, 60
- locally trivial fibration, 136
- locally finite, 93

- locally homeomorphic, 21
- locally trivial, 60
- magnetic dipole, 73
- manifold
 - smooth, 30
 - topological, 21
- maximal local flow, 134
- maximal (smooth) bundle atlas, 64
- maximal atlas, 29
- metric topology, 146
- morphism
 - of bundles, 61
- neighborhood, 146
- nonvanishing section, 62
- normal bundle
 - of a submanifold, 116
 - of an imbedding, 116
 - w.r.t. a Riemannian metric, 115
- one-to-one, 155
- onto, 155
- open ball, 146
- open set, 146
- open submanifold, 37
- orbit, 126, 134
- orientable, 15
- orientable bundle, 120
- orientable manifold, 120
- orientation
 - of a vector bundle, 120
 - on a vector space, 120
- orientation preserving isomorphism, 120
- orientation reversing isomorphism, 120
- orientation class, 120
- oriented vector space, 120
- orthogonal matrices, 83
- parallelizable, 70
- partial derivative, 159
- partition of unity, 94
- periodic immersion, 129
- pre-bundle atlas, 67
- pre-vector bundle, 67
- precomposition, 46
- preimage, *see* inverse image
- product
 - smooth, 39
 - space, 152
 - topology, 152
- product bundle, 61
- projections (from the product), 152
- proper, 137
- quadric, 87
- quotient
 - space, 150
 - topology, 150
- quotient bundle, 113
- quotient space, 110
- rank, 75
 - constant, 75
- rank theorem, 79
- real projective space, \mathbf{RP}^n , 23, 28
- refinement, 97
- reflexivity, 154
- regular
 - point, 76
 - value, 76
- represent, 44
- restriction, 149
- restriction of bundle, 102
- Riemannian manifold, 114
- Riemannian metric, 114
- Sard's theorem, 76
- second order differential equation, 141
- section, 61
- singular, 76
- skew matrix, 85
- smooth
 - bundle morphism, 65
 - bundle atlas, 63
 - manifold, 30
 - map, 31
 - map, at a point, 31

- pre-vector bundle, 67
- structure, 30
- vector bundle, 64
- solution curve
 - for first order differential equation, 130
 - for second order differential equation, 142
- special linear group, 83
- special orthogonal group, 86
- sphere, (standard smooth), 30
- stably trivial, 109
- stereographic projection, 26
- Stiefel manifold, 86
- subbundle, 101
- submanifold, 35
 - open, 37
- submersion, 81
- subordinate, 94
- subspace, 149
- sum, of smooth manifolds, 40
- support, 93
- surjective, 155
- symmetric power, 111
- symmetric bilinear form, 112
- symmetry, 154
- tangent space
 - geometric definition, 47
- tensor product, 110
- topological space, 146
- topology, 145
 - on a space, 146
- torus, 39
- total space, 60
- transition function, 62
- transitivity, 154
- transverse, 117
- trivial
 - smooth vector bundle, 64
- trivial bundle, 61
- unitary group, 86
- van der Waal's equation, 87
- vector bundle
 - n -dimensional (real topological), 59
 - smooth, 64
- vector field, 72
- velocity vector, 127
- velocity field, 125, 134
- Whitney sum, 108
- zero section, 61