

Tata McGraw-Hill



BASIC AND APPLIED THERMODYNAMICS

P K NAG



Premier12

Urheberrechtlich geschütztes Material

Information contained in this work has been obtained by Tata McGraw-Hill, from sources believed to be reliable. However, neither Tata McGraw-Hill nor its authors guarantee the accuracy or completeness of any information published herein, and neither Tata McGraw-Hill nor its authors shall be responsible for any errors, omissions, or damages arising out of use of this information. This work is published with the understanding that Tata McGraw-Hill and its authors are supplying information but are not attempting to render engineering or other professional services. If such services are required, the assistance of an appropriate professional should be sought.



Tata McGraw-Hill

© 2002, Tata McGraw-Hill Publishing Company Limited

Eighth reprint 2006
RAXDRRAKRQXQY

No part of this publication may be reproduced in any form or by any means without the prior written permission of the publishers

This edition can be exported from India by the publishers,
Tata McGraw-Hill Publishing Company Limited

ISBN 0-07-047338-2

Published by Tata McGraw-Hill Publishing Company Limited,
7 West Patel Nagar, New Delhi 110 008, typeset at Script Makers, 19,
A1-B, DDA Market, Pashchim Vihar, New Delhi 110 063 and printed at
A P Offset Pvt. Ltd., Zulfe Bengal, Dilshad Garden, Delhi 110 095

The McGraw-Hill Companies

Contents

<i>Preface</i>	<i>vii</i>
1. Introduction	1
1.1 Macroscopic vs Microscopic Viewpoint	1
1.2 Thermodynamic System and Control Volume	2
1.3 Thermodynamic Properties, Processes and Cycles	3
1.4 Homogeneous and Heterogeneous Systems	4
1.5 Thermodynamic Equilibrium	4
1.6 Quasi-Static Process	5
1.7 Pure Substance	7
1.8 Concept of Continuum	7
1.9 Thermostatistics	8
1.10 Units and Dimensions	8
1.11 History of Thermodynamics	13
<i>Solved Examples</i>	20
<i>Review Questions</i>	21
<i>Problems</i>	22
2. Temperature	24
2.1 Zeroth Law of Thermodynamics	24
2.2 Measurement of Temperature—the Reference Points	24
2.3 Comparison of Thermometers	26
2.4 Ideal Gas	27
2.5 Gas Thermometers	28
2.6 Ideal Gas Temperature	29
2.7 Celsius Temperature Scale	30
2.8 Electrical Resistance Thermometer	30
2.9 Thermocouple	31
2.10 International Practical Temperature Scale	32
<i>Solved Examples</i>	33
<i>Review Questions</i>	35
<i>Problems</i>	35
3. Work and Heat Transfer	37
3.1 Work Transfer	37
3.2 pdV -Work or Displacement Work	39
3.3 Indicator Diagram	42

3.4	Other Types of Work Transfer	44
3.5	Free Expansion with Zero Work Transfer	49
3.6	Net Work Done by a System	50
3.7	Heat Transfer	50
3.8	Heat Transfer—A Path Function	51
3.9	Specific Heat and Latent Heat	52
3.10	Point to Remember Regarding Heat Transfer and Work Transfer	53
	<i>Solved Examples</i>	54
	<i>Review Questions</i>	58
	<i>Problems</i>	59
4.	First Law of Thermodynamics	63
4.1	First Law for a Closed System Undergoing a Cycle	63
4.2	First Law for a Closed System Undergoing a Change of State	65
4.3	Energy—A Property of the System	66
4.4	Different Forms of Stored Energy	67
4.5	Specific Heat at Constant Volume	69
4.6	Enthalpy	70
4.7	Specific Heat at Constant Pressure	70
4.8	Energy of an Isolated System	71
4.9	Perpetual Motion Machine of the First Kind—PMM1	71
4.10	Limitations of the First Law	72
	<i>Solved Examples</i>	72
	<i>Review Questions</i>	77
	<i>Problems</i>	77
5.	First Law Applied to Flow Processes	81
5.1	Control Volume	81
5.2	Steady Flow Process	82
5.3	Mass Balance and Energy Balance in a Simple Steady Flow Process	83
5.4	Some Examples of Steady Flow Processes	86
5.5	Comparison of S.F.E.E. with Euler and Bernoulli Equations	90
5.6	Variable Flow Processes	91
5.7	Example of a Variable Flow Problem	93
5.8	Discharging and Charging a Tank	95
	<i>Solved Examples</i>	97
	<i>Review Questions</i>	106
	<i>Problems</i>	107
6.	Second Law of Thermodynamics	111
6.1	Qualitative Difference between Heat and Work	111
6.2	Cyclic Heat Engine	112
6.3	Energy Reservoirs	114
6.4	Kelvin-Planck Statement of Second Law	115

6.5	Clausius' Statement of the Second Law	116
6.6	Refrigerator and Heat Pump	116
6.7	Equivalence of Kelvin-Planck and Clausius Statements	119
6.8	Reversibility and Irreversibility	120
6.9	Causes of Irreversibility	121
6.10	Conditions for Reversibility	126
6.11	Carnot Cycle	126
6.12	Reversed Heat Engine	128
6.13	Carnot's Theorem	129
6.14	Corollary of Carnot's Theorem	131
6.15	Absolute Thermodynamic Temperature Scale	131
6.16	Efficiency of the Reversible Heat Engine	135
6.17	Equality of Ideal Gas Temperature and Kelvin Temperature	136
6.18	Types of Irreversibility	137
	<i>Solved Examples</i>	138
	<i>Review Questions</i>	146
	<i>Problems</i>	147

7. Entropy **152**

7.1	Introduction	152
7.2	Two Reversible Adiabatic Paths Cannot Intersect Each Other	152
7.3	Clausius' Theorem	153
7.4	The Property of Entropy	155
7.5	Principle of Caratheodory	158
7.6	The Inequality of Clausius	159
7.7	Entropy Change in an Irreversible Process	161
7.8	Entropy Principle	163
7.9	Applications of Entropy Principle	164
7.10	Entropy Transfer Mechanisms	171
7.11	Entropy Generation in a Closed System	173
7.12	Entropy Generation in an Open System	177
7.13	First and Second Laws Combined	178
7.14	Reversible Adiabatic Work in a Steady Flow System	179
7.15	Entropy and Direction: The Second Law—A Directional Law of Nature	182
7.16	Entropy and Disorder	182
7.17	Absolute Entropy	183
7.18	Entropy and Information Theory	183
7.19	Postulatory Thermodynamics	190
	<i>Solved Examples</i>	191
	<i>Review Questions</i>	204
	<i>Problems</i>	205

8. Available Energy, Exergy and Irreversibility **214**

8.1	Available Energy	214
8.2	Available Energy Referred to a Cycle	215

8.3	Quality of Energy	219
8.4	Maximum Work in a Reversible Process	222
8.5	Reversible Work by an Open System	
	Exchanging Heat only with the Surroundings	224
8.6	Useful Work	227
8.7	Dead State	229
8.8	Availability	230
8.9	Availability in Chemical Reactions	232
8.10	Irreversibility and Gouy-Stodola Theorem	234
8.11	Availability or Exergy Balance	237
8.12	Second Law Efficiency	240
8.13	Comments on Exergy	247
	Solved Examples	249
	Review Questions	271
	Problems	273
9.	Properties of Pure Substances	279
9.1	p - v Diagram for a Pure Substance	279
9.2	p - T Diagram for a Pure Substance	284
9.3	p - v - T Surface	285
9.4	T - s Diagram for a Pure Substance	285
9.5	h - s Diagram or Mollier Diagram for a Pure Substance	288
9.6	Quality or Dryness Fraction	291
9.7	Steam Tables	293
9.8	Charts of Thermodynamic Properties	295
9.9	Measurement of Steam Quality	295
	Solved Examples	302
	Review Questions	322
	Problems	322
10.	Properties of Gases and Gas Mixtures	328
10.1	Avogadro's Law	328
10.2	Equation of State of a Gas	328
10.3	Ideal Gas	331
10.4	Gas Compression	343
10.5	Equations of State	349
10.6	Virial Expansions	350
10.7	Law of Corresponding States	351
10.8	Other Equations of State	359
10.9	Properties of Mixtures of Gases—Dalton's Law of Partial Pressures	359
10.10	Internal Energy, Enthalpy and Specific Heats of Gas Mixtures	362
10.11	Entropy of Gas Mixtures	363
10.12	Gibbs Function of a Mixture of Inert Ideal Gases	365

Solved Examples 366Review Questions 383Problems 385**11. Thermodynamic Relations, Equilibrium and Third Law** 396

- 11.1 Some Mathematical Theorems 396
- 11.2 Maxwell's Equations 398
- 11.3 TdS Equations 399
- 11.4 Difference in Heat Capacities 399
- 11.5 Ratio of Heat Capacities 401
- 11.6 Energy Equation 402
- 11.7 Joule-Kelvin Effect 405
- 11.8 Clausius-Clapeyron Equation 409
- 11.9 Evaluation of Thermodynamic Properties from an Equation of State 412
- 11.10 General Thermodynamic Considerations on an Equation of State 415
- 11.11 Mixtures of Variable Composition 417
- 11.12 Conditions of Equilibrium of a Heterogeneous System 420
- 11.13 Gibbs Phase Rule 422
- 11.14 Types of Equilibrium 423
- 11.15 Local Equilibrium Conditions 426
- 11.16 Conditions of Stability 427
- 11.17 Third Law of Thermodynamics 428
- Solved Examples 434
- Review Questions 448
- Problems 449

12. Vapour Power Cycles 457

- 12.1 Simple Steam Power Cycle 457
- 12.2 Rankine Cycle 459
- 12.3 Actual Vapour Cycle Processes 462
- 12.4 Comparison of Rankine and Carnot Cycles 464
- 12.5 Mean Temperature of Heat Addition 465
- 12.6 Reheat Cycle 468
- 12.7 Ideal Regenerative Cycle 470
- 12.8 Regenerative Cycle 472
- 12.9 Reheat-Regenerative Cycle 476
- 12.10 Feedwater Heaters 477
- 12.11 Exergy Analysis of Vapour Power Cycles 479
- 12.12 Characteristics of an Ideal Working Fluid in Vapour Power Cycles 481
- 12.13 Binary Vapour Cycles 483
- 12.14 Thermodynamics of Coupled Cycles 486
- 12.15 Process Heat and By-Product Power 487

12.16	<u>Efficiencies in Steam Power Plant</u>	<u>489</u>
	<i>Solved Examples</i>	492
	<i>Review Questions</i>	513
	<i>Problems</i>	514
13.	Gas Power Cycles	521
13.1	<u>Carnot Cycle (1824)</u>	<u>521</u>
13.2	<u>Stirling Cycle (1827)</u>	<u>522</u>
13.3	<u>Ericsson Cycle (1850)</u>	<u>523</u>
13.4	<u>Air Standard Cycles</u>	<u>524</u>
13.5	<u>Otto Cycle (1876)</u>	<u>524</u>
13.6	<u>Diesel Cycle (1892)</u>	<u>527</u>
13.7	<u>Limited Pressure Cycle, Mixed Cycle or Dual Cycle</u>	<u>530</u>
13.8	<u>Comparison of Otto, Diesel, and Dual Cycles</u>	<u>532</u>
13.9	<u>Brayton Cycle</u>	<u>533</u>
13.10	<u>Aircraft Propulsion</u>	<u>548</u>
13.11	<u>Brayton-Rankine Combined Cycle</u>	<u>551</u>
	<i>Solved Examples</i>	554
	<i>Review Questions</i>	569
	<i>Problems</i>	570
14.	Refrigeration Cycles	578
14.1	<u>Refrigeration by Non-Cyclic Processes</u>	<u>578</u>
14.2	<u>Reversed Heat Engine Cycle</u>	<u>579</u>
14.3	<u>Vapour Compression Refrigeration Cycle</u>	<u>580</u>
14.4	<u>Absorption Refrigeration Cycle</u>	<u>591</u>
14.5	<u>Heat Pump System</u>	<u>595</u>
14.6	<u>Gas Cycle Refrigeration</u>	<u>596</u>
14.7	<u>Liquefaction of Gases</u>	<u>598</u>
14.8	<u>Production of Solid Ice</u>	<u>600</u>
	<i>Solved Examples</i>	600
	<i>Review Questions</i>	611
	<i>Problems</i>	612
15.	Psychrometrics	617
15.1	<u>Properties of Atmospheric Air</u>	<u>617</u>
15.2	<u>Psychrometric Chart</u>	<u>622</u>
15.3	<u>Psychrometric Processes</u>	<u>623</u>
	<i>Solved Examples</i>	631
	<i>Review Questions</i>	641
	<i>Problems</i>	642
16.	Reactive Systems	644
16.1	<u>Degree of Reaction</u>	<u>644</u>
16.2	<u>Reaction Equilibrium</u>	<u>647</u>
16.3	<u>Law of Mass Action</u>	<u>648</u>

- 16.4 Heat of Reaction 648
- [16.5 Temperature Dependence of the Heat of Reaction 650](#)
- 16.6 Temperature Dependence of the Equilibrium Constant 651
- 16.7 Thermal Ionization of a Monatomic Gas 651
- [16.8 Gibbs Function Change 653](#)
- 16.9 Fugacity and Activity 656
- [16.10 Displacement of Equilibrium Due to a Change in Temperature or Pressure 657](#)
- [16.11 Heat Capacity of Reacting Gases in Equilibrium 658](#)
- 16.12 Combustion 659
- [16.13 Enthalpy of Formation 660](#)
- 16.14 First Law for Reactive Systems 661
- [16.15 Adiabatic Flame Temperature 663](#)
- [16.16 Enthalpy and Internal Energy of Combustion: Heating Value 663](#)
- [16.17 Absolute Entropy and the Third Law of Thermodynamics 664](#)
- 16.18 Second Law Analysis of Reactive Systems 666
- 16.19 Chemical Exergy 667
- 16.20 Second Law Efficiency of a Reactive System 670
- 16.21 Fuel Cells 670
- [Solved Examples 673](#)
- Review Questions 689*
- Problems 690*

17. Compressible Fluid Flow

696

- [17.1 Velocity of Pressure Pulse in a Fluid 696](#)
- [17.2 Stagnation Properties 698](#)
- [17.3 One Dimensional Steady Isentropic Flow 700](#)
- [17.4 Critical Properties—Choking in Isentropic Flow 702](#)
- 17.5 Normal Shocks 708
- [17.6 Adiabatic Flow with Friction and Diabatic Flow without Friction 714](#)
- [Solved Examples 715](#)
- Review Questions 722*
- Problems 723*

18. Elements of Heat Transfer

726

- [18.1 Basic Concepts 726](#)
- [18.2 Conduction Heat Transfer 727](#)
- 18.3 Convective Heat Transfer 736
- 18.4 Heat Exchangers 742
- 18.5 Radiation Heat Transfer 749
- [Solved Examples 757](#)
- Review Questions 766*
- [Problems 768](#)

19. Statistical Thermodynamics	772
19.1 Quantum Hypothesis	772
19.2 Quantum Principle Applied to a System of Particles	773
19.3 Wave-Particle Duality	775
19.4 de Broglie Equation	776
19.5 Heisenberg's Uncertainty Principle	777
19.6 Wave Equation	777
19.7 Schrödinger Wave Equation	780
19.8 Probability Function: ψ	781
19.9 Particle in a Box	781
19.10 Rigid Rotator	785
19.11 Harmonic Oscillator	786
19.12 Phase Space	786
19.13 Microstate and Macrostate	787
19.14 Maxwell-Boltzmann Statistics	788
19.15 Stirling's Approximation	790
19.16 Maxwell-Boltzmann Distribution Function	791
19.17 Bose-Einstein Statistics	792
19.18 Fermi-Dirac Statistics	794
19.19 Summary of Distributions of Particles Over Energy Levels	795
19.20 Partition Function	795
19.21 Entropy and Probability	796
19.22 Monatomic Ideal Gas	799
19.23 Principle of Equipartition of Energy	802
19.24 Statistics of a Photon Gas	804
19.25 Electron Gas	806
19.26 Thermodynamic Properties	811
19.27 Specific Heat of Solids	816
<i>Solved Examples</i>	818
<i>Review Questions</i>	822
<i>Problems</i>	824
20. Irreversible Thermodynamics	826
20.1 Entropy Flow and Entropy Production	826
20.2 Onsager Equations	828
20.3 Phenomenological Laws	829
20.4 Rate of Entropy Generation: Principle of Superposition	830
20.5 Proof of Onsager's Reciprocal Relations	836
20.6 Thermoelectric Phenomena	837
20.7 Thermomechanical Phenomena	846
20.8 Stationary States	849
<i>Solved Examples</i>	851
<i>Review Questions</i>	855
<i>Problems</i>	857

21. Kinetic Theory of Gases and Distribution of Molecular Velocities	860
21.1 Molecular Model	860
21.2 Distribution of Molecular Velocities in Direction	861
21.3 Molecular Collisions with a Stationary Wall	862
21.4 Pressure of a Gas	864
21.5 Absolute Temperature of a Gas	866
21.6 Collisions with a Moving Wall	867
21.7 Clausius Equation of State	868
21.8 van der Waals Equation of State	869
21.9 Maxwell-Boltzmann Velocity Distribution	870
21.10 Average, Root-Mean-Square and Most Probable Speeds	876
21.11 Molecules in a Certain Speed Range	878
21.12 Energy Distribution Function	880
21.13 Principle of Equipartition of Energy	882
21.14 Specific Heat of a Gas	883
21.15 Specific Heats of a Solid	884
<i>Solved Examples</i>	885
<i>Review Questions</i>	892
<i>Problems</i>	894
22. Transport Processes in Gases	897
22.1 Mean Free Path and Collision Cross-section	897
22.2 Distribution of Free Paths	898
22.3 Transport Properties	901
<i>Solved Examples</i>	911
<i>Review Questions</i>	917
<i>Problems</i>	919
<i>Appendices</i>	921
<i>Bibliography</i>	973
<i>Index</i>	975

1

Introduction

Thermodynamics is the science of energy transfer and its effect on the physical properties of substances. It is based upon observations of common experience which have been formulated into thermodynamic laws. These laws govern the principles of energy conversion. The applications of the thermodynamic laws and principles are found in all fields of energy technology, notably in steam and nuclear power plants, internal combustion engines, gas turbines, air conditioning, refrigeration, gas dynamics, jet propulsion, compressors, chemical process plants, and direct energy conversion devices.

1.1 Macroscopic Vs Microscopic Viewpoint

There are two points of view from which the behaviour of matter can be studied: the macroscopic and the microscopic. In the macroscopic approach, a certain quantity of matter is considered, without the events occurring at the molecular level being taken into account. From the microscopic point of view, matter is composed of myriads of molecules. If it is a gas, each molecule at a given instant has a certain position, velocity, and energy, and for each molecule these change very frequently as a result of collisions. The behaviour of the gas is described by summing up the behaviour of each molecule. Such a study is made in *microscopic or statistical thermodynamics*. *Macroscopic thermodynamics* is only concerned with the effects of the action of many molecules, and these effects can be perceived by human senses. For example, the macroscopic quantity, pressure, is the average rate of change of momentum due to all the molecular collisions made on a unit area. The effects of pressure can be felt. The macroscopic point of view is not concerned with the action of individual molecules, and the force on a given unit area can be measured by using, e.g., a pressure gauge. These macroscopic observations are completely independent of the assumptions regarding the nature

of matter. All the results of classical or macroscopic thermodynamics can, however, be derived from the microscopic and statistical study of matter.

1.2 Thermodynamic System and Control Volume

A thermodynamic *system* is defined as a quantity of matter or a region in space upon which attention is concentrated in the analysis of a problem. Everything external to the system is called the *surroundings* or the *environment*. The system is separated from the surroundings by the system boundary (Fig. 1.1). The boundary may be either *fixed* or *moving*. A system and its surroundings together comprise a *universe*.

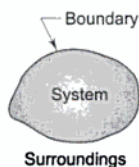

Fig. 1.1 A thermodynamic system

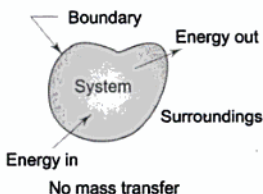

Fig. 1.2 A closed system

There are three classes of systems: (a) closed system, (b) open system and (c) isolated system. The *closed system* (Fig. 1.2) is a system of fixed mass. There is no mass transfer across the system boundary. There may be energy transfer into or out of the system. A certain quantity of fluid in a cylinder bounded by a piston constitutes a closed system. The *open system* (Fig. 1.3) is one in which matter crosses the boundary of the system. There may be energy transfer also. Most of the engineering devices are generally open systems, e.g., an air compressor in which air enters at low pressure and leaves at high pressure and there are energy transfers across the system boundary. The *isolated system* (Fig. 1.4) is one in which there is no interaction between the system and the surrounding. It is of fixed mass and energy, and there is no mass or energy transfer across the system boundary.

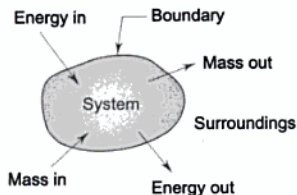

Fig. 1.3 An open system

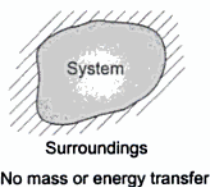

Fig. 1.4 An isolated system

If a system is defined as a certain quantity of matter, then the system contains the same matter and there can be no transfer of mass across its boundary.

However, if a system is defined as a region of space within a prescribed boundary, then matter can cross the system boundary. While the former is called a closed system, the latter is an open system.

For thermodynamic analysis of an open system, such as an air compressor (Fig. 1.5), attention is focussed on a certain volume in space surrounding the compressor, known as the *control volume*, bounded by a surface called the *control surface*. Matter as well as energy crosses the control surface.

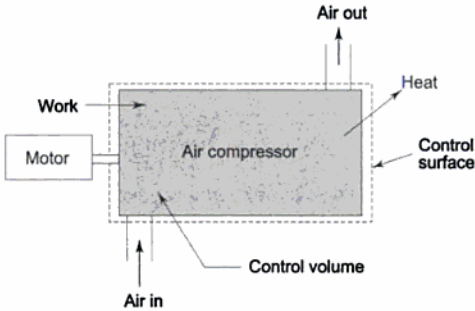

Fig. 1.5 Control volume and control surface

A closed system is a system closed to matter flow, though its volume can change against a flexible boundary. When there is matter flow, then the system is considered to be a volume of fixed identity, the control volume. There is thus no difference between an open system and a control volume.

1.3 Thermodynamic Properties, Processes and Cycles

Every system has certain characteristics by which its physical condition may be described, e.g., volume, temperature, pressure, etc. Such characteristics are called *properties* of the system. These are all *macroscopic* in nature. When all the properties of a system have definite values, the system is said to exist at a definite *state*. Properties are the coordinates to describe the state of a system. They are the state variables of the system. Any operation in which one or more of the properties of a system changes is called a *change of state*. The succession of states passed through during a change of state is called the *path* of the change of state. When the path is completely specified, the change of state is called a *process*, e.g., a constant pressure process. A thermodynamic *cycle* is defined as a series of state changes such that the final state is identical with the initial state (Fig. 1.6)

Properties may be of two types. *Intensive properties* are independent of the mass in the system, e.g., pressure, temperature, etc. *Extensive properties* are related to mass, e.g., volume, energy, etc. If mass is increased, the values of the extensive properties also increase. Specific extensive properties, i.e., extensive

properties per unit mass, are intensive properties, e.g., specific volume, specific energy, density, etc.

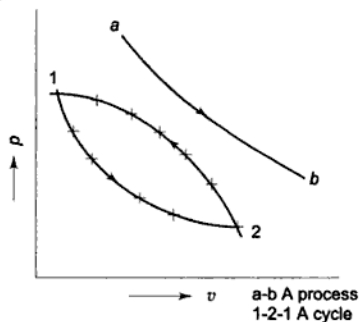

Fig. 1.6 A process and a cycle

1.4 Homogeneous and Heterogeneous Systems

A quantity of matter homogeneous throughout in chemical composition and physical structure is called a *phase*. Every substance can exist in any one of the three phases, viz., solid, liquid and gas. A system consisting of a single phase is called a *homogeneous system*, while a system consisting of more than one phase is known as a *heterogeneous system*.

1.5 Thermodynamic Equilibrium

A system is said to exist in a state of *thermodynamic equilibrium* when no change in any macroscopic property is registered, if the system is isolated from its surroundings.

An isolated system always reaches in course of time a state of thermodynamic equilibrium and *can never depart from it spontaneously*.

Therefore, there can be no *spontaneous change in any macroscopic property* if the system exists in an equilibrium state. Thermodynamics studies mainly the properties of physical systems that are found in equilibrium states.

A system will be in a state of thermodynamic equilibrium, if the conditions for the following three types of equilibrium are satisfied:

- Mechanical equilibrium
- Chemical equilibrium
- Thermal equilibrium

In the absence of any unbalanced force within the system itself and also between the system and the surroundings, the system is said to be in a state of *mechanical equilibrium*. If an unbalanced force exists, either the system alone or both the system and the surroundings will undergo a change of state till mechanical equilibrium is attained.

If there is no chemical reaction or transfer of matter from one part of the system to another, such as diffusion or solution, the system is said to exist in a state of *chemical equilibrium*.

When a system existing in mechanical and chemical equilibrium is separated from its surroundings by a diathermic wall (diathermic means 'which allows heat to flow') and if there is no spontaneous change in any property of the system, the system is said to exist in a state of *thermal equilibrium*. When this is not satisfied, the system will undergo a change of state till thermal equilibrium is restored.

When the conditions for any one of the three types of equilibrium are not satisfied, a system is said to be in a *nonequilibrium state*. If the nonequilibrium of the state is due to an unbalanced force in the interior of a system or between the system and the surrounding, the pressure varies from one part of the system to another. There is no single pressure that refers to the system as a whole. Similarly, if the nonequilibrium is because of the temperature of the system being different from that of its surroundings, there is a nonuniform temperature distribution set up within the system and there is no single temperature that stands for the system as a whole. It can thus be inferred that when the conditions for thermodynamic equilibrium are not satisfied, the states passed through by a system cannot be described by thermodynamic properties which represent the system as a whole.

Thermodynamic properties are the macroscopic coordinates defined for, and significant to, only thermodynamic equilibrium states. Both classical and statistical thermodynamics study mainly the equilibrium states of a system.

1.6 Quasi-Static Process

Let us consider a system of gas contained in a cylinder (Fig. 1.7). The system initially is in equilibrium state, represented by the properties p_1, v_1, t_1 . The weight on the piston just balances the upward force exerted by the gas. If the weight is removed, there will be an unbalanced force between the system and the surroundings, and under gas pressure, the piston will move up till it hits the stops.

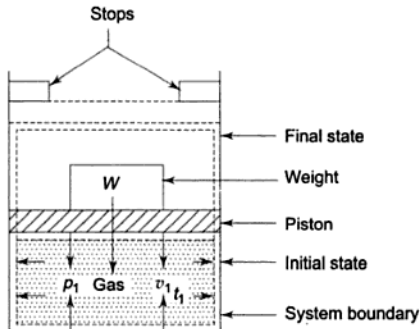

Fig. 1.7 Transition between two equilibrium states by an unbalanced force

consideration, and δF_n is the component of force normal to δA (Fig. 1.13), the pressure p at a point on the wall is defined as

$$p = \lim_{\delta A \rightarrow \delta A'} \frac{\delta F_n}{\delta A}$$

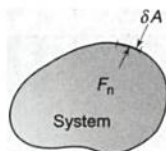

Fig. 1.13 Definition of pressure

The pressure p at a point in a fluid in equilibrium is the same in all directions.

The unit for pressure in the SI system is the *pascal* (Pa), which is the force of one newton acting on an area of 1 m^2 .

$$1 \text{ Pa} = 1 \text{ N/m}^2$$

The unit of pascal is very small. Very often kilo-pascal (kPa) or mega-pascal (MPa) is used.

Two other units, not within the SI system of units, continue to be widely used. These are the *bar*, where

$$1 \text{ bar} = 10^5 \text{ Pa} = 100 \text{ kPa} = 0.1 \text{ MPa}$$

and the standard atmosphere, where

$$1 \text{ atm} = 101.325 \text{ kPa} = 1.01325 \text{ bar}$$

Most instruments indicate pressure relative to the atmospheric pressure, whereas the pressure of a system is its pressure above zero, or relative to a perfect vacuum. The pressure relative to the atmosphere is called *gauge pressure*. The pressure relative to a perfect vacuum is called *absolute pressure*.

$$\text{Absolute pressure} = \text{Gauge pressure} + \text{Atmospheric pressure}$$

When the pressure in a system is less than atmospheric pressure, the gauge pressure becomes negative, but is frequently designated by a positive number and called *vacuum*. For example, 16 cm vacuum will be

$$\frac{76 - 16}{76} \times 1.013 = 0.08 \text{ bar}$$

Figure 1.14 shows a few pressure measuring devices. Figure (a) shows the Bourdon gauge which measures the difference between the system pressure inside the tube and atmospheric pressure. It relies on the deformation of a bent hollow tube of suitable material which, when subjected to the pressure to be measured on the inside (and atmospheric pressure on the outside), tends to unbend. This moves a pointer through a suitable gear-and-lever mechanism against a calibrated scale. Figure (b) shows an open U-tube indicating gauge pressure, and Fig. (c) shows an open U-tube indicating vacuum. Figure (d) shows a closed U-tube indicating

absolute pressure. If p is atmospheric pressure, this is a *barometer*. These are called U-tube manometers.

If Z is the difference in the heights of the fluid columns in the two limbs of the U-tube [Fig. (b) and Fig. (c)], ρ the density of the fluid and g the acceleration due to gravity, then from the elementary principle of hydrostatics, the gauge pressure p_g is given by

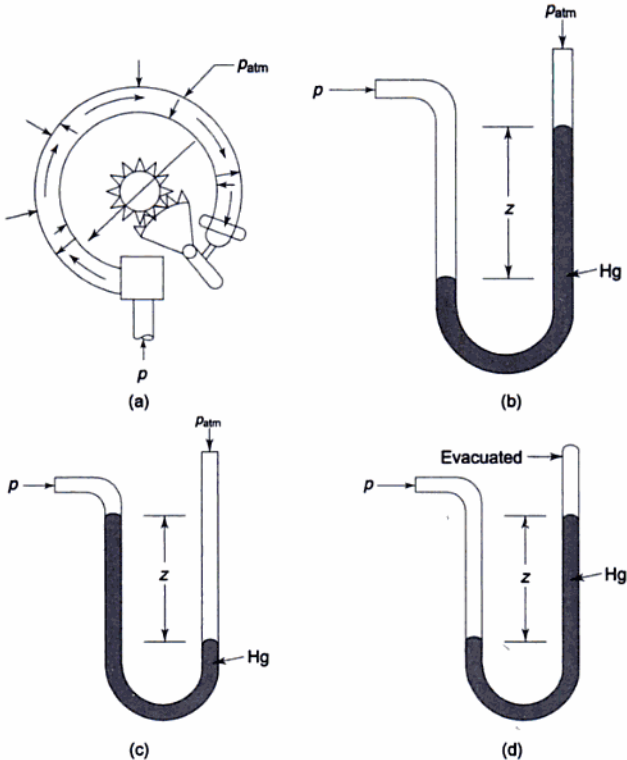

Fig. 1.14 Pressure gauges
 (a) Bourdon gauge
 (b) Open U-tube indicating gauge pressure
 (c) Open U-tube indicating vacuum
 (d) Closed U-tube indicating absolute pressure

$$\begin{aligned}
 p_g &= Z\rho g \left[m \cdot \frac{\text{kg}}{\text{m}^3} \frac{\text{m}}{\text{s}^2} \right] \\
 &= Z\rho g \text{ N/m}^2
 \end{aligned}$$

If the fluid is mercury having $\rho = 13,616 \text{ kg/m}^3$, one metre head of mercury column is equivalent to a pressure of 1.3366 bar, as shown below

$$\begin{aligned} 1 \text{ m Hg} &= Z\rho g = 1 \times 13616 \times 9.81 \\ &= 1.3366 \times 10^5 \text{ N/m}^2 \\ &= 1.3366 \text{ bar} \end{aligned}$$

The manometer is a sensitive, accurate and simple device, but it is limited to fairly small pressure differentials and, because of the inertia and friction of the liquid, is not suitable for fluctuating pressures, unless the rate of pressure change is small. A diaphragm-type pressure transducer along with a cathode ray oscilloscope can be used to measure rapidly fluctuating pressures.

1.10.3 Specific Volume and Density

Volume (V) is the space occupied by a substance and is measured in m^3 . The specific volume (v) of a substance is defined as the volume per unit mass and is measured in m^3/kg . From continuum consideration the specific volume at a point is defined as

$$v = \lim_{\delta V' \rightarrow \delta v'} \frac{\delta V}{\delta m}$$

where $\delta V'$ is the smallest volume for which the system can be considered a continuum.

Density (ρ) is the mass per unit volume of a substance, which has been discussed earlier, and is given in kg/m^3 .

$$\rho = \frac{m}{v}$$

In addition to m^3 , another commonly used unit of volume is the litre (l).

$$1 \text{ l} = 10^{-3} \text{ m}^3$$

The specific volume or density may be given either on the basis of mass or in respect of mole. A *mole* of a substance has a mass numerically equal to the molecular weight of the substance. One g mol of oxygen has a mass of 32 g and 1 kg mol (or kmol) of nitrogen has a mass of 28 kg. The symbol \bar{v} is used for molar specific volume (m^3/kmol).

1.10.4 Energy

Energy is the capacity to exert a force through a distance, and manifests itself in various forms. Engineering processes involve the conversion of energy from one form to another, the transfer of energy from place to place, and the storage of energy in various forms, utilizing a working substance.

The unit of energy in the SI system is Nm or J (joule). The energy per unit mass is the specific energy, the unit of which is J/kg.

1.10.5 Power

The rate of energy transfer or storage is called power. The unit of power is watt (W), kilowatt (kW) or megawatt (MW).

$$1 \text{ W} = 1 \text{ J/s} = 1 \text{ Nm/s}$$

$$1 \text{ kW} = 1000 \text{ W}$$

1.11 History of Thermodynamics

The latter half of the eighteenth century ushered man into the modern world of machinery and manufacture, and brought about cataclysmic changes in the social, economic and political life of the people. The historians have called it the *Industrial Revolution*. It began in England due to a fortuitous combination of many factors. There was bustling creative activity in science and technology during this period in England, with the appearance of a galaxy of some brilliant individuals. The invention of the steam engine gave an impetus to this activity, and for the first time made man free from the forces of nature. The names of Savery, Newcomen and notably James Watt are associated with this invention. Watt brought about considerable improvement in the performance of the steam engine, which began to be widely used in coal mines, iron metallurgy and textile mills. George Stephenson introduced steam engine for rail transport, and Robert Fulton used it in steam boats. A variety of industries grew up, and man gradually entered into the modern machine age. The advent of steam engine also gave stimulus to the birth of thermodynamics. Thermodynamics is said to be the "daughter" of the steam engine.

There was once a young inventor who thought that he could produce energy out of nothing. "It is well known", said he, "that an electrical motor converts electrical energy into mechanical energy and that an electric generator converts mechanical energy into electrical energy. Why not then, use the motor to run the generator and the generator to run the motor, and create thereby an endless supply of energy"? But this is never to happen. A hypothetical device which creates energy from nothing is called a perpetual motion machine of the first kind, a PMM1. Like the proverbial touchstone which changes all metals into gold, man attempted to find such a PMM1 for long long years, but it turned out to be a wild goose chase. In fact, the development of the principle of conservation of energy has been one of the most significant achievements in the evolution of physical science. The first recognition of this principle was made by Leibnitz in 1693, when he referred to the sum of kinetic energy and potential energy in a gravitational force field. Energy is neither created nor destroyed. Energy manifests in various forms and gets transformed from one form to another. Through gentle metabolic processes, a day labourer gradually transforms the chemical energy of the food he eats and the oxygen he breathes into heat, sound and useful work. Work was always considered a form of energy. The concept of heat was, however a very actively debated scientific topic. Until the middle of the nineteenth century, heat was regarded as an invisible colourless, weightless,

odourless fluid that flowed from a body of higher caloric to a body of lower caloric. This was known as the caloric theory of heat, first proposed in 1789 by Antoine Lavoisier (1743–1794), the father of modern chemistry. When an object became full of caloric, it was then said to be saturated with it. This was the origin of the terms “saturated liquid”, “saturated vapour” etc. that we use in thermodynamics today. The caloric was said to be conserved and it was indestructible. The caloric theory was, however, refuted and heat was confirmed as a form of energy in the middle of the nineteenth century leading to the formulation of the first law of thermodynamics. The names which stand out in the establishment of the first law were Benjamin Thompson (1753–1814), James Prescott Joule (1818–1889) and Julius Robert Mayer (1814–1978).

Benjamin Thompson, an American born in Massachusetts, did not support the revolt against the British during the American war of independence, and in 1775 he left for England where he took up government service. On a trip to Germany, he met the prince of Bavaria who offered him a job. He introduced many reforms in the government for which the title of Count von Rumford was conferred on him. While boring brass cannon hole, Count Rumford noticed that there was a continuous heat release. How could the caloric fluid be conserved, when it was being produced continuously by mechanical friction? From the established principle of conservation of mass, a true fluid can be neither created nor destroyed, so heat could not be a fluid if it could be continuously created in an object by mechanical friction. Rumford conceived that heat was “a kind of motion” and the hotness of an object was due to the vibrating motion of the particles in the object. On his return to England, he became a member of the Royal Society, and later founded the Royal Institution for the Advancement of Science. Rumford married the widow of Lavoisier and lived in Paris for the rest of his eventful life.

In the early forties of the nineteenth century, James P. Joule and Julius R. Mayer almost simultaneously set forth the idea that heat transfer and mechanical work were simply different forms of the same quantity, which we now recognize as energy in transit. In some modern treatments of engineering thermodynamics, Joule’s name alone is attached to the establishment of the equivalence of “heat” and “work”. The published record, however, shows that the idea of convertibility of heat into work was published independently by Mayer in May, 1842 and Joule in August, 1843. For an important aspect in the history of the first law, is the fact that both Mayer and Joule had difficulty in getting their papers published and in being taken seriously by their established contemporaries.

Robert Mayer was a doctor in a ship in the East Indies and from physiological observations, he believed in a principle of conservation of energy. He derived theoretically, the mechanical heat equivalent based on the calorimetric data of Joseph Black of Glasgow University. Mayer tried to publish his paper but remained unsuccessful for a long time. His despair was so great that he attempted suicide by jumping from a window, but he only broke his two legs. He was placed in an asylum for some time. In later years, however, he was given some measure

or recognition and honoured equally with Joule in establishing the mechanical theory of heat.

Mayer argued that an amount of gas needs to be heated more at constant pressure than at constant volume, because at constant pressure it is free to dilate and do work against the atmosphere, which in today's notations becomes:

$$mc_p \Delta T - mc_v \Delta T = P_{\text{atm}} \Delta V \quad (1.2)$$

Using the c_p and c_p/c_v constants that were known in his time, he estimated the left-hand side of the equation in calories, while the right-hand side was known in mechanical units. He thus established numerically the equivalence between these units. If the relation

$$Pv = RT \quad (1.3)$$

is used in Eq. (1.2), Mayer's argument reduces to

$$c_p - c_v = R \quad (1.4)$$

This classic relationship between the specific heats of an ideal gas is called Mayer's equation; while the ideal gas equation of state, Eq. (1.3), was first derived by Clapeyron [Bejan, 1988].

Joule was the ultimate experimentalist. His experiments seem to be the direct continuation of those of Rumford and the gap of some forty years between the two investigations appeared puzzling to some authors. Joule's first discovery from his measurements was that the flow of current in a resistance, is accompanied by the development of heat proportional to the resistance. He concluded that caloric was indeed created by the flow of current. He was firmly convinced that there existed some conservation law of a general nature and hence set out to investigate whether the conversion of the various forms of energy is governed by definite conversion factors. He considered the conversion of chemical, electric, caloric, and mechanical energy forms in all combinations. The determination of the mechanical equivalent of heat forms the central part of his experiments, the results of which can be summed up in the general relation:

$$W = JQ \quad (1.5)$$

where J is the mechanical equivalent of heat. Joule's experiments suggested that this relation may have universal validity with the same numerical value of J under all conditions.

Joule communicated the results of his experiments to the British Association for the Advancement of Science in 1843. It was received with entire incredulity and general silence. In 1844 a paper by Joule on the same subject was rejected by the Royal Society. To convince the skeptics, he produced a series of nakedly simple experiments whose message proved impossible to refute. From the point of view of mechanical engineers, the most memorable among these experiments was the heating of a pool of water by an array of paddle wheels driven by falling

* Adrian Bejan, "Research into the Origins of Engineering Thermodynamics", Int. Comm. Heat Mass Transfer, Vol. 15, No. 5, 1988, pp 571-580.

weights. He discussed in 1847, before the British Association at Oxford, his experimental results in which he suggested that the water at the bottom of the Niagara waterfall (160 feet high) should be warmer than at the top (by 0.2°F). From the thermal expansion of gases Joule deduced that there should be a "zero of temperature", 480°F below the freezing point of ice. This was the first suggestion of absolute zero. Although these results failed to provoke further discussion, it created interest in a young man who only two years ago had passed from the University of Cambridge with the highest honour. The young man was William Thomson, who later became Lord Kelvin. He somewhere stated that it was one of the most valuable recollections of his life. Michael Faraday was also present in the 1844 Oxford meeting, and he communicated Joule's paper "On the Mechanical Equivalent of Heat" to the Royal Society in 1849.

The paper ultimately appeared in its Philosophical Transactions in 1850.

Even while Joule was perfecting the experimental basis of the energy law now called the Mayer-Joule principle, Herman Ludwig von Helmholtz (1821–1894) published in 1847, his famous essay on the conservation of force. In this work, he advanced the conservation of energy as a unifying principle extending over all branches of physics. Helmholtz, like Mayer, was a physician by profession and self-taught in Physics and Mathematics. He also faced great difficulties in getting his paper published in professional journals.

In the history of classical thermodynamics, one thinks of only the closed system formulations of the first law which were deliberated by the pioneers as stated above. In engineering thermodynamics, however, open system formulations are of prime interest. The first law for open systems was first stated by Gustave Zeuner, as part of the analysis of flow systems that operate in the steady state. Zeuner's formula for the heat transfer rate to a stream m in steady flow and without shaft work in present notations is given to be:

$$d\dot{Q}/\dot{m} = d(u + Pv + V^2/2 + gz) \quad (1.6)$$

The reference of this formula is found in Stodola's classic treatise on steam turbines, first published in the German language in 1903.

The first person to invent a theory simultaneously involving the ideas of conservation and conversion of energy was the young French military engineer Nicolas Leonard Sadi Carnot (1796–1832). The strikingly original ideas of Carnot's work make it among the most brilliant new departures in theoretical physics. Sadi Carnot was the son of Napoleon's general, Lazare Carnot, and was educated at the famous Ecole Polytechnique in Paris. Between 1794 and 1830, Ecole Polytechnique had such famous teachers as Lagrange, Fourier, Laplace, Ampere, Cauchy, Coriolis, Poisson, Gay-Lussac, and Poiseuille. After his formal education Carnot chose a career as an army officer. Britain was then a powerful military force, primarily as a result of the industrial revolution brought about by the steam engine. French technology was not developing as fast as Britain's. Carnot was convinced that France's inadequate utilization of steam power had made it militarily inferior. He began to study the fundamentals of steam engine technology, and in 1824 he published the results of his study in the form of a

brochure "Reflection on the Motive Power of Heat and on Machines Fitted to Develop that Power". Carnot was trained in the basic principles of hydraulics, pumps and water wheels at the Ecole Polytechnique. During Carnot's time, caloric theory of heat was still persisting, and the water wheel as the major source of mechanical power was gradually getting replaced by the steam engine. Carnot conceived that the power of a steam engine was released, as the heat fluid or caloric fell from the high temperature of the boiler to the lower temperature of the condenser, in much the same way that water falls through a water wheel to produce mechanical shaft work output. Carnot stated, "The motive power of a water wheel depends on its height and the quantity of liquid. The motive power of heat also depends on the quantity of caloric used and on the height of its fall, i.e., the difference of temperatures of the bodies between which the exchange of caloric is made".

Till Carnot's time thermodynamics was developed primarily on an empirical basis provided by chemistry. Carnot approached an engineering problem, the efficiency of heat engines, in terms of entirely new concepts with the steam engine serving as the stimulus. Carnot observed that the existence of temperature differences is a necessary condition for producing mechanical work by means of a heat engine. He simplified the problem to its bare essentials and stipulates, that this system, consisting essentially of a working substance, should exchange heat with its surroundings only at two fixed temperatures. In order to conceptualize such a situation, he introduces the idea of heat reservoirs. Two important conclusions emerged from Carnot's work:

1. No one could build a water wheel that would produce a continuous work output unless water actually entered and exited the wheel. If water with a certain kinetic and potential energy entered the wheel, then the same amount of water with a lower energy must also exit the wheel. It is thus impossible to make a water wheel that converts all the energy of the inlet water into shaft work output. There must be an outflow of water from the wheel.

If this idea is extended to a steam engine by replacing the water by heat fluid caloric, it can be concluded that when caloric at a certain energy level (temperature) enters a work producing heat engine, it must also exit the heat engine at a low energy level (temperature). Thus a continuously operating heat engine that converts all of its caloric (heat) input directly into work output is not possible. This is very close to the Kelvin-Planck statement of second law as it is known today.

2. The maximum efficiency of a water wheel was independent of the type of the liquid and depended only on the inlet and outlet flow energies. The maximum efficiency of the steam engine (or any heat engine) depends only on the temperatures of the high and low temperature thermal reservoirs of the engine and is independent of the working fluid. To achieve the maximum efficiency there must not be any mechanical friction or other losses of any kind.

Only at the age of 36, Sadi Carnot died of cholera following an attack of scarlet fever. The significance of Carnot's work was not recognized until 1850, when Rudolf Clausius (1822–1888) and William Thomson (1824–1907) worked out a

clear formulation of the conservation of energy principle. Carnot's first conclusion was then called the second law of thermodynamics by Clausius, and Thomson used Carnot's second conclusion to develop the concept of absolute temperature scale. Thermodynamics is thus said to have originated from the "clumsy puffing of the early steam engines" and is often called "the daughter of steam engine".

Carnot's ideas were so revolutionary that they were largely ignored. Soon after Carnot's death, Emile Clapeyron (1799–1864), a French mining engineer, strengthened Carnot's ideas by using more precise mathematical derivation. Clapeyron constructed its thermodynamic cycle by deducing that it must be composed of two reversible isothermal processes and two reversible adiabatic processes. It is now known as Carnot's cycle. It was the first heat engine cycle to be conceptualized. No other heat engine can equal its efficiency.

Clapeyron was later able to derive a relation for the enthalpy change of the liquid to vapour phase (h_{fg}) in terms of pressure, temperature and specific volume. This provided the first equation, now called the Clausius-Clapeyron equation, representing the first order phase transition, which could be used to estimate a property that is not directly measurable in terms of properties that are directly measurable. Clapeyron's equation is now most easily derived from one of Maxwell's equations.

William Thomson (1824–1907), who became a professor of natural philosophy at the University of Glasgow in 1848 at the age of 24 only, rejected the caloric theory of heat and for the first time used the terms "thermodynamics" and "mechanical energy". Apart from the deduction of the absolute temperature scale, Thomson worked with Joule from 1852 to 1862 in a series of experiments to measure the temperature of gas in a controlled expansion and propounded the Joule-Thomson effect for real gases.

Rudolf Julius Emanuel Clausius (1822–1888) realised that there were two distinct laws at work, the first law due to Joule and Mayer and the second law as expounded by Carnot. He defined the internal energy U . Although both Kelvin and Clausius used the function Q_{rev}/T for some years, Clausius recognized the value of this function and to describe it he coined the word "entropy" from the Greek word "tropee" meaning "transformation" and assigned it the symbol S . Clausius in 1865, summarised the first and second laws of thermodynamics in the following words:

"Die Energie der Welt ist konstant.

Die Entropie der Welt strebt einem Maximum zu"

which is translated as

"The energy of the world is constant.

The entropy of the world tends toward a maximum".

The world here means the universe, the system and the surroundings together.

These statements made a strong impression upon a young student, Max Karl Ernst Ludwig Planck (1858–1947). He was educated at the universities of Munich and Berlin. In his autobiography he stated, "One day I happened to come

across the treatises of Rudolf Clausius, whose lucid style and enlightening clarity of reasoning made an enormous impression on me, and I became deeply absorbed in his articles, with an ever increasing enthusiasm. I appreciated especially his exact formulation of the two laws of thermodynamics, and the sharp distinction, which he was the first to establish between them". In 1897, Planck¹ demonstrated the close connection between the second law and the concept of reversibility. He stated the second law as the impossibility of a cyclic device which produces positive work and exchanges heat with a single reservoir. Similar statement was also made by Kelvin, and is now recognized as Kelvin-Planck statement of second law. Poincare² in 1908, extended the work of Planck and prescribed a complete structure of classical thermodynamics.

The property, entropy, plays a stellar role in thermodynamics. It was introduced via the concept of heat engines. In 1909, the Greek mathematician Caratheodory proved the existence of entropy function mathematically without the aid of Carnot engines and refrigerators. Caratheodory's statement of second law may be stated as: "In the neighbourhood of any arbitrary state P_0 of a physical system, there exist neighbouring states which are not accessible from P_0 along quasi-static adiabatic paths". From the standpoint of the engineer and physicist it is entirely mathematical in form and devoid of physical insight.

William John Macquorn Rankine (1820–1872) defined the thermodynamic efficiency of a heat engine and showed the usefulness of p - v diagrams as related to work. He wrote the first text book on thermodynamics³, and was the first to work out the thermodynamic cycle for the adiabatic cylinder steam engine, now known as Rankine cycle for a vapour power cycle.

In 1862, the cycle used in modern gasoline-powered I.C. engines was proposed in a patent issued to Alphonse Beau de Rochas (1815–1893). The first practical engine was, however, built by Nikolous August Otto (1832–1891) which was demonstrated at the Paris Exposition in 1878. Otto fought many legal battles with Beau de Rochas for production of these engines, but finally lost to him.

Captain John Ericsson (1803–1889) was a Swedish engineer who marketed small solar-powered and coal-fired hot air engines. Rev. Robert Stirling (1790–1879), an English parish minister, patented a practical heat engine in 1816 that used air as the working fluid. In theory, the cycle used in the Stirling engine approaches the ideal cycle later proposed by Carnot (1824).

George Bailey Brayton (1830–1892), an American engineer, marketed an I.C. engine with a separate combustion chamber, where combustion of fuel occurred

-
1. M. Planck, *Treatise on Thermodynamics* (1897), translated by A. Ogg, Longman and Green; London, 1927.
 2. H. Poincare, *Thermodynamique*, Gauthier-Villars, Paris, 1908.
 3. W.J.M. Rankine, "*Manual of the Steam Engine and other Prime Movers*", 1859 going through 17 editions, as mentioned by Robert Balmer in "*Thermodynamics*", West Publishing Co., 1990, page 399.

at about constant pressure. This cycle later formed the basis for modern gas turbine plants.

Gottlieb Daimler (1834–1900) obtained a patent in 1879 for a multicylinder automotive engine, which was commercially successful. Dr. Rudolf Christian Karl Diesel (1858–1913) studied at Technische Hochschule in Munich. He designed large steam engines and boilers. He later developed in 1897 an I.C. engine with fuel injection which resembled the modern diesel engine. Failing health, continuing criticism and serious financial setbacks beset Diesel who in 1913 disappeared from a boat crossing the English channel in a moonlit night.

Josiah Willard Gibbs (1839–1903) is often regarded as the most brilliant thermodynamicist produced in the USA. He received the first doctorate degree in engineering in the USA (Yale University). He contributed significantly in many areas of thermodynamics like heterogeneous systems, phase rule, physical chemistry and statistical thermodynamics. Some of his very important papers were published in obscure journals like Connecticut Academy of Sciences, and remained unknown to most scientists. Only after his death, these were discovered.

SOLVED EXAMPLES

Example 1.1 The pressure of gas in a pipe line is measured with a mercury manometer having one limb open to the atmosphere (Fig. Ex. 1.1). If the difference in the height of mercury in the two limbs is 562 mm, calculate the gas pressure. The barometer reads 761 mm Hg, the acceleration due to gravity is 9.79 m/s^2 , and the density of mercury is $13,640 \text{ kg/m}^3$.

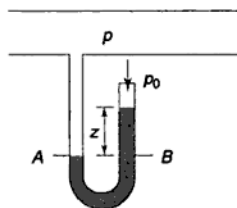

Fig. Ex. 1.1

Solution At the plane AB , we have

$$p = p_0 + \rho g z$$

Now

$$p_0 = \rho g z_0$$

where z_0 is the barometric height, ρ the density of mercury and p_0 the atmospheric pressure.

Therefore

$$\begin{aligned} p &= \rho g (z + z_0) \\ &= 13,640 \text{ kg/m}^3 \times 9.79 \text{ m/s}^2 (0.562 + 0.761) \text{ m} \end{aligned}$$

$$= 177 \times 10^3 \text{ N/m}^2 = 177 \text{ kPa}$$

$$= 1.77 \text{ bar} = 1.746 \text{ atm}$$

Ans.

Example 1.2 A turbine is supplied with steam at a gauge pressure of 1.4 MPa. After expansion in the turbine the steam flows into a condenser which is maintained at a vacuum of 710 mm Hg. The barometric pressure is 772 mm Hg. Express the inlet and exhaust steam pressure in pascals (absolute). Take the density of mercury as $13.6 \times 10^3 \text{ kg/m}^3$.

Solution The atmospheric pressure p_0

$$= \rho g z_0 = 13.6 \times 10^3 \text{ kg/m}^3 \times 9.81 \text{ m/s}^2 \times 0.772 \text{ m}$$

$$= 1.03 \times 10^5 \text{ Pa}$$

Inlet steam pressure

$$= [(1.4 \times 10^6) + (1.03 \times 10^5)] \text{ Pa}$$

$$= 15.03 \times 10^5 \text{ Pa}$$

$$= 1.503 \text{ MPa}$$

Ans.

Condenser pressure

$$= (0.772 - 0.710) \text{ m} \times 9.81 \text{ m/s}^2 \times 13.6 \times 10^3 \text{ kg/m}^3$$

$$= 0.827 \times 10^4 \text{ Pa}$$

$$= 8.27 \text{ kPa}$$

Ans.

REVIEW QUESTIONS

- 1.1 What do you understand by macroscopic and microscopic viewpoints?
- 1.2 Is thermodynamics a misnomer for the subject?
- 1.3 How does the subject of thermodynamics differ from the concept of heat transfer?
- 1.4 What is the scope of classical thermodynamics?
- 1.5 What is a thermodynamic system?
- 1.6 What is the difference between a closed system and an open system?
- 1.7 An open system defined for a fixed region and a control volume are synonymous. Explain.
- 1.8 Define an isolated system.
- 1.9 Distinguish between the terms 'change of state', 'path', and 'process'.
- 1.10 What is a thermodynamic cycle?
- 1.11 What are intensive and extensive properties?
- 1.12 What do you mean by homogeneous and heterogeneous systems?
- 1.13 Explain what you understand by thermodynamic equilibrium.
- 1.14 Explain mechanical, chemical and thermal equilibrium.
- 1.15 What is a quasi-static process? What is its characteristic feature?
- 1.16 What is the concept of continuum? How will you define density and pressure using this concept?
- 1.17 What is vacuum? How can it be measured?
- 1.18 What is a pressure transducer?

PROBLEMS

- 1.1 A pump discharges a liquid into a drum at the rate of $0.0032 \text{ m}^3/\text{s}$. The drum, 1.50 m in diameter and 4.20 m in length, can hold 3000 kg of the liquid. Find the density of the liquid and the mass flow rate of the liquid handled by the pump.
- 1.2 The acceleration of gravity is given as a function of elevation above sea level by $g = 980.6 - 3.086 \times 10^{-6} H$ where g is in cm/s^2 , and H is in cm. If an aeroplane weighs 90,000 N at sea level, what is the gravity force upon it at 10,000 m elevation? What is the percentage difference from the sea-level weight?
- 1.3 Prove that the weight of a body at an elevation H above sea-level is given by

$$W = \frac{mg}{g_0} \left(\frac{d}{d + 2H} \right)^2$$

where d is the diameter of the earth.

- 1.4 The first artificial earth satellite is reported to have encircled the earth at a speed of 28,840 km/h and its maximum height above the earth's surface was stated to be 916 km. Taking the mean diameter of the earth to be 12,680 km, and assuming the orbit to be circular, evaluate the value of the gravitational acceleration at this height.

The mass of the satellite is reported to have been 86 kg at sea-level. Estimate the gravitational force acting on the satellite at the operational altitude.

Ans. 8.9 m/s^2 ; 765 N

- 1.5 Convert the following readings of pressure to kPa, assuming that the barometer reads 760 mm Hg:

(a) 90 cm Hg gauge, (b) 40 cm Hg vacuum, (c) 1.2 m H_2O gauge, (d) 3.1 bar.

- 1.6 A 30 m high vertical column of a fluid of density $1878 \text{ kg}/\text{m}^3$ exists in a place where $g = 9.65 \text{ m}/\text{s}^2$. What is the pressure at the base of the column?

Ans. 544 kPa

- 1.7 Assume that the pressure p and the specific volume v of the atmosphere are related according to the equation $pv^{1.4} = 2.3 \times 10^3$, where p is in N/m^2 abs and v is in m^3/kg . The acceleration due to gravity is constant at $9.81 \text{ m}/\text{s}^2$. What is the depth of atmosphere necessary to produce a pressure of 1.0132 bar at the earth's surface? Consider the atmosphere as a fluid column.

Ans. 64.8 km

- 1.8 The pressure of steam flowing in a pipe line is measured with a mercury manometer, shown in Fig. P. 1.8. Some steam condenses into water. Estimate the steam pressure in kPa. Take the density of mercury as $13.6 \times 10^3 \text{ kg}/\text{m}^3$, density of water as $10^3 \text{ kg}/\text{m}^3$, the barometer reading as 76.1 cm Hg, and g as $9.806 \text{ m}/\text{s}^2$.

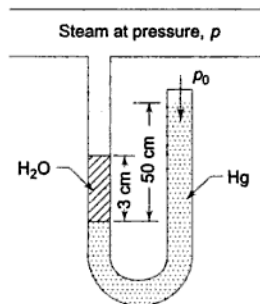

Fig. P.1.8

- 1.9 A vacuum gauge mounted on a condenser reads 0.66 m Hg. What is the absolute pressure in the condenser in kPa when the atmospheric pressure is 101.3 kPa?
Ans. 8.8 kPa
- 1.10 The basic barometer can be used to measure the height of a building. If the barometric readings at the top and at the bottom of a building are 730 and 760 mm Hg, respectively, determine the height of the building. Assume an average air density of 1.18 kg/m^3 .

2

Temperature

2.1 Zeroth Law of Thermodynamics

The property which distinguishes thermodynamics from other sciences is temperature. One might say that temperature bears as important a relation to thermodynamics as force does to statics or velocity does to dynamics. Temperature is associated with the ability to distinguish hot from cold. When two bodies at different temperatures are brought into contact, after some time they attain a common temperature and are then said to exist in thermal equilibrium.

When a body A is in thermal equilibrium with a body B, and also separately with a body C, then B and C will be in thermal equilibrium with each other.

This is known as the *zeroth law of thermodynamics*. It is the basis of temperature measurement.

In order to obtain a quantitative measure of temperature, a reference body is used, and a certain physical characteristic of this body which changes with temperature is selected. The changes in the selected characteristic may be taken as an indication of change in temperature. The selected characteristic is called the *thermometric property*, and the reference body which is used in the determination of temperature is called the *thermometer*. A very common thermometer consists of a small amount of mercury in an evacuated capillary tube. In this case the extension of the mercury in the tube is used as the thermometric property.

There are five different kinds of thermometer, each with its own thermometric property, as shown in Table 2.1.

2.2 Measurement of Temperature—the Reference Points

The temperature of a system is a property that determines whether or not a system is in thermal equilibrium with other systems. If a body is at, say, 70°C , it will be 70°C , whether measured by a mercury-in-glass thermometer, resist-

ance thermometer or constant volume gas thermometer. If X is the thermometric property, let us arbitrarily choose for the temperature common to the thermometer and to all systems in thermal equilibrium with it the following linear function of X :

Table 2.1 *Thermometers and Thermometric Properties*

Thermometer	Thermometric property	Symbol
1. Constant volume gas thermometer	Pressure	p
2. Constant pressure gas thermometer	Volume	V
3. Electrical resistance thermometer	Resistance	R
4. Thermocouple	Thermal e.m.f.	ϵ
5. Mercury-in-glass thermometer	Length	L

$$\theta(X) = aX, \text{ where } a \text{ is an arbitrary constant.}$$

If X_1 corresponds to $\theta(X_1)$, then X_2 will correspond to

$$\frac{\theta(X_1)}{X_1} \cdot X_2$$

that is

$$\theta(X_2) = \frac{\theta(X_1)}{X_1} \cdot X_2 \quad (2.1)$$

Two temperatures on the linear X scale are to each other as the ratio of the corresponding X 's.

2.2.1 Method in Use Before 1954

The thermometer is first placed in contact with the system whose temperature $\theta(X)$ is to be measured, and then in contact with an arbitrarily chosen standard system in an easily reproducible state where the temperature is $\theta(X_1)$. Thus

$$\frac{\theta(X_1)}{\theta(X)} = \frac{X_1}{X} \quad (2.2)$$

Then the thermometer at the temperature $\theta(X)$ is placed in contact with another arbitrarily chosen standard system in another easily reproducible state where the temperature is $\theta(X_2)$. It gives

$$\frac{\theta(X_2)}{\theta(X)} = \frac{X_2}{X} \quad (2.3)$$

From Eqs (2.2) and (2.3)

$$\frac{\theta(X_1) - \theta(X_2)}{\theta(X)} = \frac{X_1 - X_2}{X}$$

$$\text{or} \quad \theta(X) = \frac{\theta(X_1) - \theta(X_2)}{X_1 - X_2} \cdot X \quad (2.4)$$

If we assign an arbitrary number of degrees to the temperature interval $\theta(X_1) - \theta(X_2)$, then $\theta(X)$ can be calculated from the measurements of X , X_1 and X_2 .

An easily reproducible state of an arbitrarily chosen standard system is called a *fixed point*. Before 1954, there were two fixed points: (a) *the ice point*, the temperature at which pure ice coexisted in equilibrium with air-saturated water at one atmosphere pressure, and (b) *the steam point*, the temperature of equilibrium between pure water and pure steam at one atmosphere pressure. The temperature interval, $\theta(X_1) - \theta(X_2)$, between these two fixed points was chosen to be 100 degrees.

The use of two fixed points was found unsatisfactory and later abandoned, because of (a) the difficulty of achieving equilibrium between pure ice and air-saturated water (since when ice melts, it surrounds itself only with pure water and prevents intimate contact with air-saturated water), and (b) extreme sensitiveness of the steam point to the change in pressure.

2.2.2 Method in Use After 1954

Since 1954 only one fixed point has been in use, viz., *the triple point of water*, the state at which ice, liquid water and water vapour coexist in equilibrium. The temperature at which this state exists is arbitrarily assigned the value of 273.16 degrees Kelvin, or 273.16 K (the reason for using Kelvin's name will be explained later). Designating the triple point of water by θ_t , and with X_t being the value of the thermometric property when the body, whose temperature θ is to be measured, is placed in contact with water at its triple point, it follows that

$$\theta_t = aX_t$$

$$\therefore a = \frac{\theta_t}{X_t} = \frac{273.16}{X_t}$$

Therefore

$$\begin{aligned} \theta &= aX \\ &= \frac{273.16}{X_t} \cdot X \end{aligned}$$

$$\text{or} \quad \theta = 273.16 \frac{X}{X_t} \quad (2.5)$$

The temperature of the triple point of water, which is an easily reproducible state, is now the *standard fixed point of thermometry*.

2.3 Comparison of Thermometers

Applying the above principle to the five thermometers listed in table 2.1, the temperatures are given as

- | | |
|---------------------------------------|--|
| (a) Constant volume gas thermometer | $\theta(P) = 273.16 \frac{P}{P_t}$ |
| (b) Constant pressure gas thermometer | $\theta(V) = 273.16 \frac{V}{V_t}$ |
| (c) Electric resistance thermometer | $\theta(R) = 273.16 \frac{R}{R_t}$ |
| (d) Thermocouple | $\theta(\mathcal{E}) = 273.16 \frac{\mathcal{E}}{\mathcal{E}_t}$ |
| (e) Liquid-in-glass thermometer | $\theta(L) = 273.16 \frac{L}{L_t}$ |

If the temperature of a given system is measured simultaneously with each of the five thermometers, it is found that there is considerable difference among the readings. The smallest variation is, however, observed among different gas thermometers. That is why a gas is chosen as the standard thermometric substance.

2.4 Ideal Gas

It has been established from experimental observations that the $p - v - T$ behaviour of gases at a low pressure is closely given by the following relation

$$p\bar{v} = \bar{R}T \quad (2.6)$$

where \bar{R} is the universal gas constant, 8.3143 J/mol K and \bar{v} is the molar specific volume, m^3/gmol . (see Sec. 10.3.). Dividing Eq. (2.6) by the molecular weight μ ,

$$pv = RT \quad (2.7)$$

where v is specific volume, in m^3/kg , and R is the characteristic gas constant.

Substituting $R = \bar{R}/\mu$ J/kg K, we get in terms of the total volume V of gas,

$$\begin{aligned} PV &= n\bar{R}T \\ PV &= mRT \end{aligned} \quad (2.8)$$

where n is the number of moles and m is the mass of the gas. Equation (2.8) can be written for two states of the gas,

$$\frac{p_1 V_1}{T_1} = \frac{p_2 V_2}{T_2} \quad (2.9)$$

Equation (2.6), (2.7) or (2.8) is called the *ideal gas equation of state*. At very low pressure or density, all gases and vapour approach ideal gas behaviour.

2.5 Gas Thermometers

A schematic diagram of a constant volume gas thermometer is given in Fig. 2.1. A small amount of gas is enclosed in bulb *B* which is in communication via the capillary tube *C* with one limb of the mercury manometer *M*. The other limb of the mercury manometer is open to the atmosphere and can be moved vertically to adjust the mercury levels so that the mercury just touches lip *L* of the capillary. The pressure in the bulb is used as a thermometric property and is given by

$$p = p_0 + \rho_M Zg$$

where p_0 is the atmospheric pressure and ρ_M is the density of mercury.

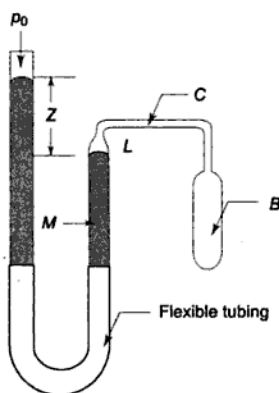

Fig. 2.1 Constant volume gas thermometer

When the bulb is brought in contact with the system whose temperature is to be measured, the bulb, in course of time, comes in thermal equilibrium with the system. The gas in the bulb expands, on being heated, pushing the mercury downward. The flexible limb of the manometer is then adjusted so that the mercury again touches the lip *L*. The difference in mercury level *Z* is recorded and the pressure *p* of the gas in the bulb is estimated. Since the volume of the trapped gas is constant, from the ideal gas equation,

$$\Delta T = \frac{V}{R} \Delta p \quad (2.10)$$

i.e. the temperature increase is proportional to the pressure increase.

In a constant pressure gas thermometer, the mercury levels have to be adjusted to keep *Z* constant, and the volume of gas *V*, which would vary with the temperature of the system, becomes the thermometric property.

$$\Delta T = \frac{p}{R} \Delta V \quad (2.11)$$

i.e. the temperature increase is proportional to the observed volume increase. The constant volume gas thermometer is, however, mostly in use, since it is simpler in construction and easier to operate.

2.6 Ideal Gas Temperature

Let us suppose that the bulb of a constant volume gas thermometer contains an amount of gas such that when the bulb is surrounded by water at its triple point, the pressure p_t is 1000 mm Hg. Keeping the volume V constant, let the following procedure be conducted:

(a) Surround the bulb with steam condensing at 1 atm, determine the gas pressure p and calculate

$$\theta = 273.16 \frac{p}{1000}$$

(b) Remove some gas from the bulb so that when it is surrounded by water at its triple point, the pressure p_t is 500 mm Hg. Determine the new values of p and then θ for steam condensing at 1 atm.

$$\theta = 273.16 \frac{p}{500}$$

(c) Continue reducing the amount of gas in the bulb so that p_t and p have smaller and smaller values, e.g., p_t having, say, 250 mm Hg, 100 mm Hg, and so on. At each value of p_t calculate the corresponding θ .

(d) Plot θ vs. p_t and extrapolate the curve to the axis where $p_t = 0$. Read from the graph

$$\lim_{p_t \rightarrow 0} \theta$$

The graph, as shown in Fig. 2.2, indicates that although the readings of a constant volume gas thermometer depend upon the nature of the gas, *all gases indicate the same temperature as p_t is lowered and made to approach zero.*

A similar series of tests may be conducted with a constant pressure gas thermometer. The constant pressure may first be taken to be 1000 mm Hg, then 500 mm Hg, etc. and at each value of p , the volumes of gas V and V_t may be recorded when the bulb is surrounded by steam condensing at 1 atm and the triple point of water, respectively. The corresponding value of θ may be calculated from

$$\theta = 273.16 \frac{V}{V_t}$$

and θ vs. p may be plotted, similar to Fig. 2.2. It is found from the experiments that all gases indicate the same value of θ as p approach zero.

Since a real gas, as used in the bulb, behaves as an ideal gas as pressure approaches zero (which would be explained later in Chapter 10), the *ideal gas temperature* T is defined by either of the two equations

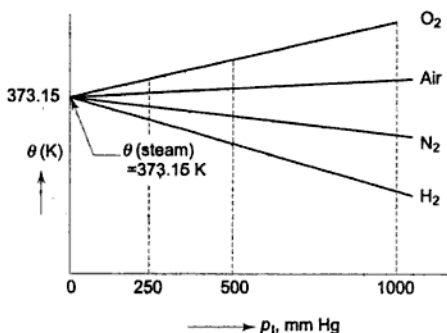

Fig. 2.2 Ideal gas temperature for steam point

$$\begin{aligned}
 T &= 273.16 \lim_{p_t \rightarrow 0} \frac{p}{p_t} \\
 &= 273.16 \lim_{p \rightarrow 0} \frac{V}{V_t}
 \end{aligned}$$

where θ has been replaced by T to denote this particular temperature scale, the *ideal gas temperature scale*.

2.7 Celsius Temperature Scale

The Celsius temperature scale employs a degree of the same magnitude as that of the ideal gas scale, but its zero point is shifted, so that the Celsius temperature of the triple point of water is 0.01 degree Celsius or 0.01°C. If t denotes the Celsius temperature, then

$$t = T - 273.15^\circ$$

Thus the Celsius temperature t_s at which steam condenses at 1 atm. pressure

$$\begin{aligned}
 t_s &= T_s - 273.15^\circ \\
 &= 373.15 - 273.15 \\
 &= 100.00^\circ\text{C}
 \end{aligned}$$

Similar measurements for ice points show this temperature on the Celsius scale to be 0.00°C. The only Celsius temperature which is fixed by definition is that of the triple point.

2.8 Electrical Resistance Thermometer

In the resistance thermometer (Fig. 2.3) the change in resistance of a metal wire due to its change in temperature is the thermometric property. The wire, fre-

quently platinum, may be incorporated in a Wheatstone bridge circuit. The platinum resistance thermometer measures temperature to a high degree of accuracy and sensitivity, which makes it suitable as a standard for the calibration of other thermometers.

In a restricted range, the following quadratic equation is often used

$$R = R_0(1 + At + Bt^2)$$

where R_0 is the resistance of the platinum wire when it is surrounded by melting ice and A and B are constants.

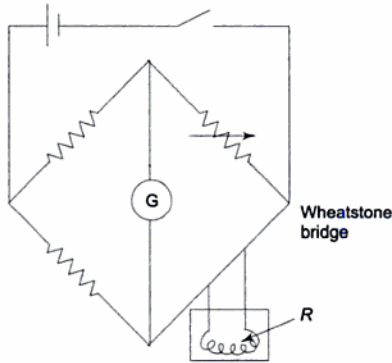

Fig. 2.3 Resistance thermometer

2.9 Thermocouple

A thermocouple circuit made up from joining two wires A and B made of dissimilar metals is shown in Fig. 2.4. Due to the Seebeck effect, a net e.m.f. is generated in the circuit which depends on the difference in temperature between the hot and cold junctions and is, therefore, a thermometric property of the circuit. This e.m.f. can be measured by a microvoltmeter to a high degree of

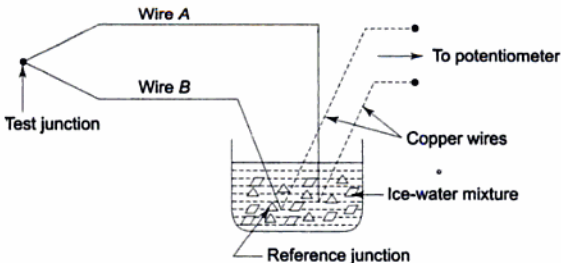

Fig. 2.4 Thermocouple

accuracy. The choice of metals depends largely on the temperature range to be investigated, and copper-constantan, chromel-alumel and platinum-platinum-rhodium are typical combinations in use.

A thermocouple is calibrated by measuring the thermal e.m.f. at various known temperatures, the reference junction being kept at 0°C. The results of such measurements on most thermocouples can usually be represented by a cubic equation of the form

$$\varepsilon = a + bt + ct^2 + dt^3$$

where ε is the thermal e.m.f. and the constants a , b , c and d are different for each thermocouple.

The advantage of a thermocouple is that it comes to thermal equilibrium with the system, whose temperature is to be measured, quite rapidly, because its mass is small.

2.10 International Practical Temperature Scale

An international temperature scale was adopted at the Seventh General Conference on Weights and Measures held in 1927. It was not to replace the Celsius or ideal gas scales, but to provide a scale that could be easily and rapidly used to calibrate scientific and industrial instruments. Slight refinements were incorporated into the scale in revisions adopted in 1948, 1954, 1960 and 1968. The international practical scale agrees with the Celsius scale at the defining fixed points listed in Table 2.2. The temperature interval from the oxygen point to the gold point is divided into three main parts, as given below.

Table 2.2 *Temperatures of Fixed Points*

	Temperature °C
Normal boiling point of oxygen	-182.97
Triple point of water (standard)	+0.01
Normal boiling point of water	100.00
Normal boiling point of sulphur	444.60
(Normal melting point of zinc-suggested as an alternative to the sulphur point)	419.50
Normal melting point of antimony	630.50
Normal melting point of silver	960.80
Normal melting point of gold	1063.00

(a) **From 0 to 660°C** A platinum resistance thermometer with a platinum wire whose diameter must lie between 0.05 and 0.20 mm is used, and the temperature is given by the equation

$$R = R_0(1 + At + Bt^2)$$

where the constants R_0 , A , and B are computed by measurements at the ice point, steam point, and sulphur point.

(b) **From - 190 to 0°C** The same platinum resistance thermometer is used, and the temperature is given by

$$R = R_0[1 + At + Bt^2 + C(t - 100)t^3]$$

where R_0 , A and B are the same as before, and C is determined from a measurement at the oxygen point.

(c) **From 660 to 1063°C** A thermocouple, one wire of which is made of platinum and the other of an alloy of 90% platinum and 10% rhodium, is used with one junction at 0°C. The temperature is given by the formula

$$\varepsilon = a + bt + ct^2$$

where a , b , and c are computed from measurements at the antimony point, silver point, and gold point. The diameter of each wire of the thermocouple must lie between 0.35 to 0.65 mm.

An optical method is adopted for measuring temperatures higher than the gold point. The intensity of radiation of any convenient wavelength is compared with the intensity of radiation of the same wavelength emitted by a black body at the gold point. The temperature is then determined with the help of Planck's law of thermal radiation.

SOLVED EXAMPLES

Example 2.1 Two mercury-in-glass thermometers are made of identical materials and are accurately calibrated at 0°C and 100°C. One has a tube of constant diameter, while the other has a tube of conical bore, ten per cent greater in diameter at 100°C than at 0°C. Both thermometers have the length between 0 and 100 subdivided uniformly. What will be the straight bore thermometer read in a place where the conical bore thermometer reads 50°C?

Solution The volume of mercury in the tube at $t^\circ\text{C}$, V_t , is given by

$$V_t = V_0 [1 + \beta (t - t_0)]$$

where V_0 is the volume of mercury at 0°C, β is the coefficient of volume expansion of mercury, and t_0 is the ice point temperature which is 0°C. The volume change of glass is neglected.

$$\text{Therefore } V_t - V_0 = \beta V_0 t$$

The temperature t is thus a linear function of volume change of mercury ($V_t - V_0$).

$$\begin{aligned} \text{Therefore } \Delta V_{0-100} &= \beta V_0 \cdot 100 \\ \Delta V_{0-50} &= \beta V_0 \cdot 50 \end{aligned}$$

$$\therefore \frac{\Delta V_{0-50}}{\Delta V_{0-100}} = \frac{1}{2}$$

i.e., the 50°C, the volume of mercury will be half of that at 100°C, for the straight bore thermometer (Fig. Ex. 2.1a).

But if the bore is conical (Fig. Ex. 2.1b), mercury will fill up the volume $ACDB$, which is less than half of the mercury volume at 100°C , i.e., volume $AEFB$. Let t be the true temperature when mercury rises half the length of the conical tube (the apparent temperature being 50°C). Let EA and FB be extended to meet at G . Let l represent the length of the thermometers and l' the vertical height of the cone ABG , as shown in the figure. Now,

$$\frac{l'}{l+l'} = \frac{d}{1.1d} = \frac{1}{1.1}$$

$$l' = 10$$

and

$$\frac{l'}{l'+l/2} = \frac{d}{CD}$$

\therefore

$$CD = \frac{10.5}{10}d = 1.05d$$

Again

$$\Delta V_{0-100} = V_0 \cdot \beta \cdot 100$$

$$\Delta V_{0-t} = V_0 \beta t$$

$$\frac{\Delta V_{0-t}}{\Delta V_{0-100}} = \frac{t}{100}$$

or

$$\frac{\text{Volume } ACDB}{\text{Volume } AEFB} = \frac{t}{100}$$

or

$$\frac{\frac{1}{3} \frac{\pi}{4} (1.05d)^2 \times 10.5l - \frac{1}{3} \frac{\pi}{4} d^2 \cdot 10l}{\frac{1}{3} \frac{\pi}{4} (1.1d)^2 \times 11l - \frac{1}{3} \frac{\pi}{4} d^2 \cdot 10l} = \frac{t}{100}$$

or

$$\frac{1.05 \times 1.05 \times 10.5 - 10}{1.1 \times 1.1 \times 11 - 10} = \frac{t}{100}$$

\therefore

$$t = \frac{1.58}{3.31} \times 100 = 47.7^\circ\text{C} \quad \text{Ans.}$$

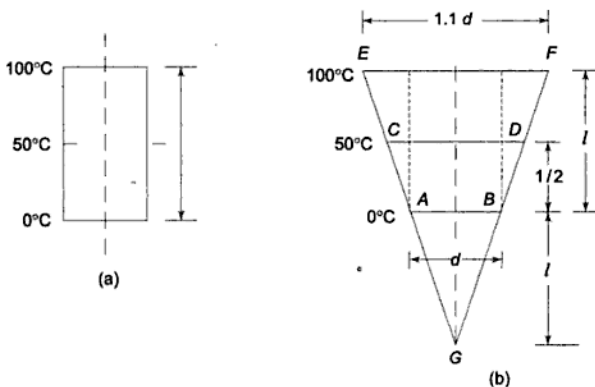

Fig. Ex 2.1

Example 2.2 The e.m.f. in a thermocouple with the test junction at $t^\circ\text{C}$ on gas thermometer scale and reference junction at ice point is given by

$$e = 0.20 t - 5 \times 10^{-4} t^2 \text{ mV}$$

The millivoltmeter is calibrated at ice and steam points. What will this thermometer read in a place where the gas thermometer reads 50°C ?

Solution At ice point, when $t = 0^\circ\text{C}$, $\varepsilon = 0 \text{ mV}$

$$\begin{aligned} \text{At steam point, when } t = 100^\circ\text{C, } \varepsilon &= 0.20 \times 100 - 5 \times 10^{-4} \times (100)^2 \\ &= 15 \text{ mV} \end{aligned}$$

$$\text{At } t = 50^\circ\text{C, } \varepsilon = 0.20 \times 50 - 5 \times 10^{-4} (50)^2 = 8.75 \text{ mV}$$

When the gas thermometer reads 50°C , the thermocouple will read

$$\frac{100}{15} \times 8.75, \text{ or } 58.33^\circ\text{C}$$

Ans.

REVIEW QUESTIONS

- 2.1 What is the zeroth law of thermodynamics?
- 2.2 Define thermometric property.
- 2.3 What is a thermometer?
- 2.4 What is a fixed point?
- 2.5 How many fixed points were used prior to 1954? What are these?
- 2.6 What is the standard fixed point in thermometry? Define it.
- 2.7 Why is a gas chosen as the standard thermometric substance?
- 2.8 What is an ideal gas?
- 2.9 What is the difference between the universal gas constant and a characteristic gas constant?
- 2.10 What is a constant volume gas thermometer? Why is it preferred to a constant pressure gas thermometer?
- 2.11 What do you understand by the ideal gas temperature scale?
- 2.12 How can the ideal gas temperature for the steam point be measured?
- 2.13 What is the Celsius temperature scale?
- 2.14 What is the advantage of a thermocouple in temperature measurement?
- 2.15 How does the resistance thermometer measure temperature?
- 2.16 What is the need of the international practical temperature scale?

PROBLEMS

- 2.1 The limiting value of the ratio of the pressure of gas at the steam point and at the triple point of water when the gas is kept at constant volume is found to be 1.36605. What is the ideal gas temperature of the steam point?
- 2.2 In a constant volume gas thermometer the following pairs of pressures readings were taken at the boiling point of water and the boiling point of sulphur, respectively:

Water b.p.	50.0	100	200	300
Sulphur b.p.	96.4	193	387	582

The numbers are the gas pressures, mm Hg, each pair being taken with the same amount of gas in the thermometer, but the successive pairs being taken with different amounts of gas in the thermometer. Plot the ratio of $S_{b.p.}: H_2O_{b.p.}$ against the reading at the water boiling point, and extrapolate the plot to zero pressure at the water boiling point. This gives the ratio of $S_{b.p.}: H_2O_{b.p.}$ on a gas thermometer operating at zero gas pressure, i.e., an ideal gas thermometer. What is the boiling point of sulphur on the gas scale, from your plot?

Ans. 445°C

- 2.3 The resistance of a platinum wire is found to be 11,000 ohms at the ice point, 15.247 ohms at the steam point, and 28.887 ohms at the sulphur point. Find the constants A and B in the equation

$$R = R_0(1 + At + Bt^2)$$

and plot R against t in the range 0 to 660°C.

- 2.4 When the reference junction of a thermocouple is kept at the ice point and the test junction is the Celsius temperature t , and e.m.f. ε of the thermocouple is given by the equation

$$\varepsilon = at + bt^2$$

where $a = 0.20$ mV/deg, and $b = -50 \times 10^{-4}$ mV/deg²

- (a) Compute the e.m.f. when $t = -100^\circ\text{C}$, 200°C , 400°C , and 500°C , and draw graph of ε against t in this range.
 (b) Suppose the e.m.f. ε is taken as a thermometric property and that a temperature scale t^* is defined by the linear equation.

$$t^* = a' \varepsilon + b'$$

and that $t^* = 0$ at the ice point and $t^* = 100$ at the steam point. Find the numerical values of a' and b' and draw a graph of ε against t^* .

- (c) Find the values of t^* when $t = -100^\circ\text{C}$, 200°C , 400°C , and 500°C , and draw a graph of t^* against t .
 (d) Compare the Celsius scale with the t^* scale.
 2.5 The temperature t on a thermometric scale is defined in terms of a property K by the relation

$$t = a \ln K + b$$

where a and b are constants.

The values of K are found to be 1.83 and 6.78 at the ice point and the steam point, the temperatures of which are assigned the numbers 0 and 100 respectively. Determine the temperature corresponding to a reading of K equal to 2.42 on the thermometer.

Ans. 21.346°C

- 2.6 The resistance of the windings in a certain motor is found to be 80 ohms at room temperature (25°C). When operating at full load under steady state conditions, the motor is switched off and the resistance of the windings, immediately measured again, is found to be 93 ohms. The windings are made of copper whose resistance at temperature $t^\circ\text{C}$ is given by

$$R_t = R_0 [1 + 0.00393 t]$$

where R_0 is the resistance at 0°C . Find the temperature attained by the coil during full load.

Ans. 70.41°C

Work and Heat Transfer

A closed system and its surroundings can interact in two ways: (a) by work transfer, and (b) by heat transfer. These may be called *energy interactions* and these bring about changes in the properties of the system. Thermodynamics mainly studies these energy interactions and the associated property changes of the system.

3.1 Work Transfer

Work is one of the basic modes of energy transfer. In mechanics the action of a force on a moving body is identified as work. A force is a means of transmitting an effect from one body to another. But a force itself never produces a physical effect except when coupled with motion and hence it is not a form of energy. An effect such as the raising of a weight through a certain distance can be performed by using a small force through a large distance or a large force through a small distance. The product of force and distance is the same to accomplish the same effect. In mechanics work is defined as:

The work is done by a force as it acts upon a body moving in the direction of the force.

The action of a force through a distance (or of a torque through an angle) is called *mechanical work* since other forms of work can be identified, as discussed later. The product of the force and the distance moved parallel to the force is the magnitude of mechanical work.

In thermodynamics, work transfer is considered as occurring between the system and the surroundings. *Work is said to be done by a system if the sole effect on things external to the system can be reduced to the raising of a weight.* The weight may not actually be raised, but the net effect external to the system would be the raising of a weight. Let us consider the battery and the motor in Fig. 3.1 as a system. The motor is driving a fan. The system is doing work upon

the surroundings. When the fan is replaced by a pulley and a weight, as shown in Fig. 3.2, the weight may be raised with the pulley driven by the motor. The sole effect on things external to the system is then the raising of a weight.

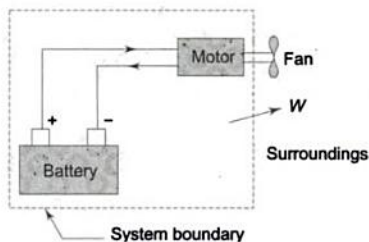

Fig. 3.1 Battery-motor system driving a fan

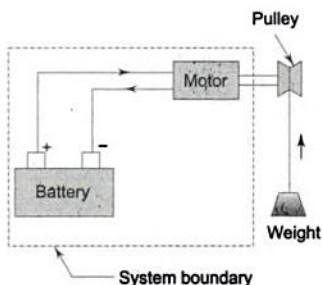

Fig. 3.2 Work transfer from a system

When work is done by a system, it is arbitrarily taken to be positive, and when work is done on a system, it is taken to be negative (Fig. 3.3.). The symbol W is used for work transfer.

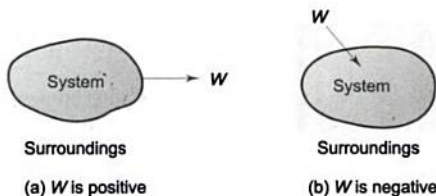

Fig. 3.3 Work interaction between a system and the surroundings

The unit of work is N.m or Joule [$1 \text{ Nm} = 1 \text{ Joule}$]. The rate at which work is done by, or upon, the system is known as *power*. The unit of power is J/s or watt.

Work is one of the forms in which a system and its surroundings can interact with each other. There are various types of work transfer which can get involved between them.

3.2 $p dV$ -Work or Displacement Work

Let the gas in the cylinder (Fig. 3.4) be a system having initially the pressure p_1 and volume V_1 . The system is in thermodynamic equilibrium, the state of which is described by the coordinates p_1, V_1 . The piston is the only boundary which moves due to gas pressure. Let the piston move out to a new final position 2, which is also a thermodynamic equilibrium state specified by pressure p_2 and volume V_2 . At any intermediate point in the travel of the piston, let the pressure be p and the volume V . This must also be an equilibrium state, since macroscopic properties p and V

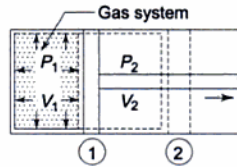

Fig. 3.4 $p dV$ work

are significant only for equilibrium states. When the piston moves an infinitesimal distance dl , and if ' a ' be the area of the piston, the force F acting on the piston $F = p \cdot a$. and the infinitesimal amount of work done by the gas on the piston

$$\delta W = F \cdot dl = padl = pdV \quad (3.1)$$

where $dV = a dl =$ infinitesimal displacement volume. The differential sign in dW with the line drawn at the top of it will be explained later.

When the piston moves out from position 1 to position 2 with the volume changing from V_1 to V_2 , the amount of work W done by the system will be

$$W_{1-2} = \int_{V_1}^{V_2} p dV$$

The magnitude of the work done is given by the area under the path 1-2, as shown in Fig. 3.5. Since p is at all times a thermodynamic coordinate, all the states passed through by the system as the volume changes from V_1 to V_2 must be equilibrium states, and the path 1-2 must be *quasi-static*. The piston moves infinitely slowly so that

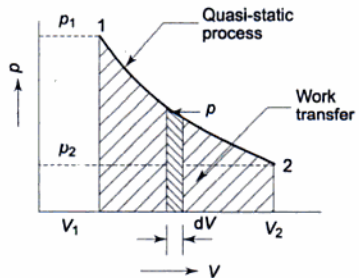

Fig. 3.5 *Quasi-static* $p dV$ work

every state passed through is an equilibrium state. *The integration $\int p dV$ can be performed only on a quasi-static path.*

3.2.1 Path Function and Point Function

With reference to Fig. 3.6, it is possible to take a system from state 1 to state 2 along many quasi-static paths, such as *A*, *B* or *C*. Since the area under each curve represents the work for each process, the amount of work involved in each case is not a function of the end states of the process, and it depends on the path the system follows in going from state 1 to state 2. For this reason, work is called a *path function*, and δW is an *inexact or imperfect differential*.

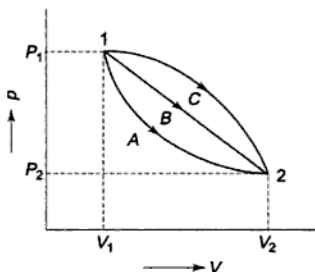

Fig. 3.6 Work—a path function

Thermodynamic properties are *point functions*, since for a given state, there is a definite value for each property. The change in a thermodynamic property of a system in a change of state is independent of the path the system follows during the change of state, and depends only on the initial and final states of the system. The differentials of point functions are *exact or perfect differentials*, and the integration is simply

$$\int_{V_1}^{V_2} dV = V_2 - V_1$$

The change in volume thus depends only on the end states of the system irrespective of the path the system follows.

On the other hand, work done in a quasi-static process between two given states depends on the path followed.

$$\int_1^2 \delta W \neq W_2 - W_1$$

Rather,

$$\int_1^2 \delta W = W_{1-2} \text{ or } {}_1W_2$$

To distinguish an inexact differential δW from an exact differential dV or dp the differential sign is being cut by a line at its top.

From Eq. (3.1),

$$dV = \frac{1}{p} dW \quad (3.2)$$

Here, $1/p$ is called the *integrating factor*. Therefore, an inexact differential dW when multiplied by an integrating factor $1/p$ becomes an exact differential dV .

For a cyclic process, the initial and final states of the system are the same, and hence, the change in any property is zero, i.e.

$$\oint dV = 0, \oint dp = 0, \oint dT = 0 \quad (3.3)$$

where the symbol \oint denotes the cyclic integral for the closed path. Therefore, *the cyclic integral of a property is always zero.*

3.2.2 $p dV$ -Work in Various Quasi-Static Processes

(a) Constant pressure process (Fig. 3.7) (isobaric or isopiestic process)

$$W_{1-2} = \int_{V_1}^{V_2} p dV = p(V_2 - V_1) \quad (3.4)$$

(b) Constant volume process (Fig. 3.8) (isochoric process)

$$W_{1-2} = \int p dV = 0 \quad (3.5)$$

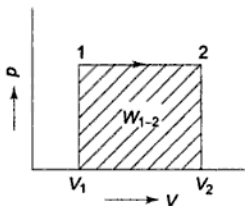

Fig. 3.7 Constant pressure process

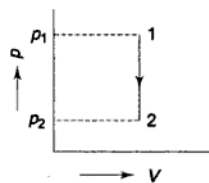

Fig. 3.8 Constant volume process

(c) Process in which $pV = C$ (Fig. 3.9)

$$\therefore W_{1-2} = \int_{V_1}^{V_2} p dV, \quad pV = p_1 V_1 = C$$

$$p = \frac{(p_1 V_1)}{V}$$

$$W_{1-2} = p_1 V_1 \int_{V_1}^{V_2} \frac{dV}{V} = p_1 V_1 \ln \frac{V_2}{V_1}$$

$$= p_1 V_1 \ln \frac{p_1}{p_2} \quad (3.6)$$

(d) Process in which $pV^n = C$, where n is a constant (Fig. 3.10).

$$pV^n = p_1 V_1^n = p_2 V_2^n = C$$

$$\therefore p = \frac{(p_1 V_1^n)}{V^n}$$

$$\begin{aligned} \therefore W_{1-2} &= \int_{V_1}^{V_2} p dV \\ &= \int_{V_1}^{V_2} \frac{p_1 V_1^n}{V^n} \cdot dV \\ &= (p_1 V_1^n) \left[\frac{V^{-n+1}}{-n+1} \right]_{V_1}^{V_2} \\ &= \frac{p_1 V_1^n}{1-n} (V_2^{1-n} - V_1^{1-n}) \\ &= \frac{p_2 V_2^n \times V_2^{1-n} - p_1 V_1^n \times V_1^{1-n}}{1-n} \\ &= \frac{p_1 V_1 - p_2 V_2}{n-1} = \frac{p_1 V_1}{n-1} \left[1 - \left(\frac{p_2}{p_1} \right)^{n-1/n} \right] \quad (3.7) \end{aligned}$$

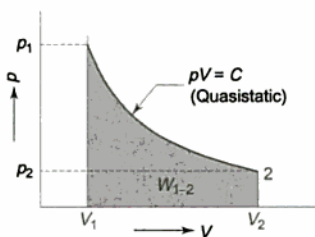

Fig. 3.9 Process in which $pV = \text{constant}$

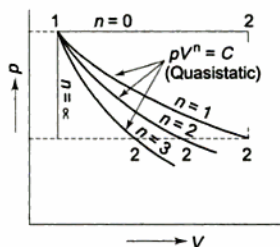

Fig. 3.10 Process in which $pV^n = \text{constant}$

3.3 Indicator Diagram

An indicator diagram is a trace made by a recording pressure gauge, called the indicator, attached to the cylinder of a reciprocating engine. This represents the work done in one engine cycle. Figure 3.11 shows a typical engine indicator.

The same gas pressure acts on both the engine piston P and the indicator piston I . The indicator piston is loaded by a spring and it moves in direct proportion to the change in pressure. The motion of the indicator piston causes a pencil held at the end of the linkage L to move upon a strip of paper wrapped around drum D . The drum is rotated about its axis by cord C , which is

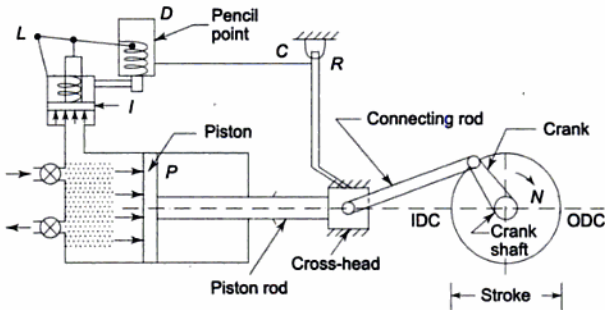

Fig. 3.11 Engine indicator

connected through a reducing motion R to the piston P of the engine. The surface of drum D moves horizontally under the pencil while the pencil moves vertically over the surface and a plot of pressure upon the piston vs. piston travel is obtained.

Before tracing the final indicator diagram, a pressure reference line is recorded by subjecting the indicator to the atmosphere and tracing a line at a constant pressure of one atmosphere.

The area of the indicator diagram represents the magnitude of the net work done by the system in one engine cycle. The area under the path 1-2 represents work done by the system and the area under the path 2-1 represents work done upon the system (Fig. 3.12). The area of the diagram, a_d , is measured by means of a planimeter, and the length of the diagram, l_d , is also measured. The *mean effective pressure* (m.e.p.) p_m is defined in the following way

$$p_m = \frac{a_d}{l_d} \times K$$

where K is the indicator spring constant ($\text{N/cm}^2 \times \text{cm travel}$). Work done in one engine cycle

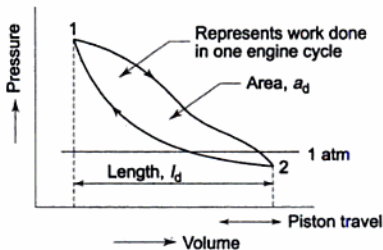

Fig. 3.12 Indicator diagram

$$= (p_m \cdot A) L$$

where A = cross-sectional area of the cylinder

$$= \frac{\pi}{4} D^2, \text{ where } D \text{ is the cylinder diameter}$$

and L = stroke of piston, or length of cylinder.

Let N be the revolutions per minute (r.p.m.) of the crankshaft. In a two stroke cycle, the engine cycle is completed in two strokes of the piston or in one revolution of the crankshaft. In a four-stroke cycle, the engine cycle is completed in four strokes of the piston or two revolutions of the crankshaft.

For a two-stroke engine, work done in one minute = $p_m ALN$, and for a four-stroke engine, work done in one minute = $p_m ALN/2$.

The power developed inside the cylinder of the engine is called *indicated power* (IP),

$$\therefore \text{IP} = \frac{p_m AL \left(N \text{ or } \frac{N}{2} \right) n}{60} \text{ kW} \quad (3.8)$$

where p_m is in kPa and n is the number of cylinders in the engine.

The power available at the crankshaft is always less than this value (IP) due to friction, etc. and is called the *brake power* (BP) or *shaft power* (SP). If ω is the angular velocity of the crankshaft in radian/sec, then

$$\text{BP} = T \omega \quad (3.9)$$

where T is the torque transmitted to the crankshaft in mN.

$$\therefore \text{BP} = \frac{2\pi TN}{60} \quad (3.10)$$

where N is the number of revolutions per minute (rpm).

The mechanical efficiency of the engine, η_{mech} , is defined as

$$\eta_{\text{mech}} = \frac{\text{BP}}{\text{IP}} \quad (3.11)$$

An engine is said to be *double-acting*, if the working fluid is made to work on both sides of the piston. Such an engine theoretically develops twice the amount of work developed in a single-acting engine. Most reciprocating steam engines are double-acting, and so are many marine diesel engines. Internal combustion engines for road transport are always single-acting.

3.4 Other Types of Work Transfer

There are forms of work other than pdV or displacement work. The following are the additional types of work transfer which may get involved in system-surroundings interactions.

(a) **Electrical Work** When a current flows through a resistor (Fig. 3.13), taken as a system, there is work transfer into the system. This is because the current can drive a motor, the motor can drive a pulley and the pulley can raise a weight.

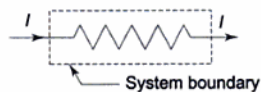

Fig. 3.13 Electrical work

The current flow, I , in amperes, is given by

$$I = \frac{dC}{d\tau}$$

where C is the charge in coulombs and τ is time in seconds. Thus dC is the charge crossing a boundary during time $d\tau$. If E is the voltage potential, the work is

$$\begin{aligned} dW &= E \cdot dC \\ &= EI d\tau \end{aligned}$$

$$\therefore W = \int_1^2 EI d\tau \quad (3.12)$$

The electrical power will be

$$\dot{W} = \lim_{d\tau \rightarrow 0} \frac{dW}{d\tau} = EI \quad (3.13)$$

This is the rate at which work is transferred.

(b) Shaft Work When a shaft, taken as the system (Fig. 3.14), is rotated by a motor, there is work transfer into the system. This is because the shaft can rotate a pulley which can raise a weight. If T is the torque applied to the shaft and $d\theta$ is the angular displacement of the shaft, the shaft work is

$$W = \int_1^2 T d\theta \quad (3.14)$$

and the shaft power is

$$\dot{W} = \int_1^2 T \frac{d\theta}{d\tau} = T \omega \quad (3.15)$$

where ω is the angular velocity and T is considered a constant in this case.

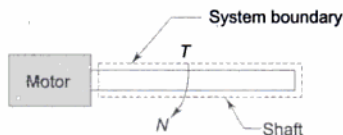

Fig. 3.14 Shaft work

(c) Paddle-Wheel Work or Stirring Work As the weight is lowered, and the paddle wheel turns (Fig. 3.15), there is work transfer into the fluid system

which gets stirred. Since the volume of the system remains constant, $\int p dV = 0$. If m is the mass of the weight lowered through a distance dz and T is the torque transmitted by the shaft in rotating through an angle $d\theta$, the differential work transfer to the fluid is given by

$$dW = mgdz = Td\theta$$

and the total work transfer is

$$W = \int_1^2 mgdz = \int_1^2 W' dz = \int_1^2 Td\theta \quad (3.15)$$

where W' is the weight lowered.

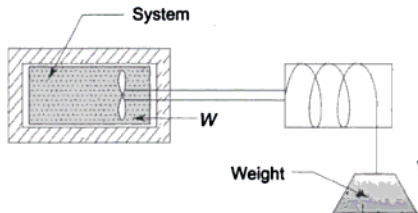

Fig. 3.15 Paddle-wheel work

(d) Flow Work The flow work, significant only in a flow process or an open system, represents the energy transferred across the system boundary as a result of the energy imparted to the fluid by a pump, blower or compressor to make the fluid flow across the control volume. Flow work is analogous to displacement work. Let p be the fluid pressure in the plane of the imaginary piston, which acts in a direction normal to it (Fig. 3.16). The work done on this imaginary piston by the external pressure as the piston moves forward is given by

$$dW_{\text{flow}} = pdV, \quad (3.16)$$

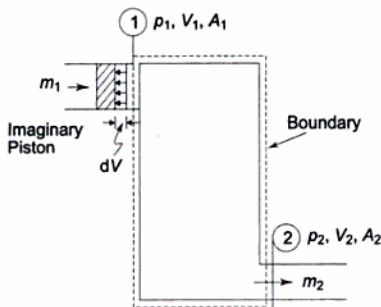

Fig. 3.16 Flow work

where dV is the volume of fluid element about to enter the system.

$$\therefore \quad \delta W_{\text{flow}} = p v \, dm \quad (3.17)$$

where $dV = v \, dm$

Therefore, flow work at inlet (Fig. 3.16),

$$(\delta W_{\text{flow}})_{\text{in}} = p_1 v_1 \, dm_1 \quad (3.18)$$

Equation (3.18) can also be derived in a slightly different manner. If the normal pressure p_1 is exerted against the area A_1 , giving a total force ($p_1 A_1$) against the piston, in time $d\tau$, this force moves a distance $V_1 d\tau$, where V_1 is the velocity of flow (piston). The work in time $d\tau$ is $p_1 A_1 V_1 d\tau$, or the work per unit time is $p_1 A_1 V_1$. Since the flow rate

$$w_1 = \frac{A_1 V_1}{v_1} = \frac{dm_1}{d\tau}$$

the work done in time $d\tau$ becomes

$$(\delta W_{\text{flow}})_{\text{in}} = p_1 v_1 \, dm_1$$

Similarly, flow work of the fluid element leaving the system is

$$(\delta W_{\text{flow}})_{\text{out}} = p_2 v_2 \, dm_2 \quad (3.19)$$

The flow work per unit mass is thus

$$W_{\text{flow}} = p v \quad (3.20)$$

It is the displacement work done at the moving system boundary.

(e) Work Done in Stretching a Wire Let us consider a wire as the system. If the length of the wire in which there is a tension \mathcal{F} is changed from L to $L + dL$, the infinitesimal amount of work that is done is equal to

$$\delta W = -\mathcal{F} \, dL$$

The minus sign is used because a positive value of dL means an expansion of the wire, for which work must be done on the wire, i.e., negative work. For a finite change of length,

$$W = - \int_1^2 \mathcal{F} \, dL \quad (3.21)$$

If we limit the problem to within the elastic limit, where E is the modulus of elasticity, s is the stress, ϵ is the strain, and A is the cross-sectional area, then

$$\mathcal{F} = sA = E\epsilon A, \text{ since } \frac{s}{\epsilon} = E$$

$$d\epsilon = \frac{dL}{L}$$

$$\delta W = -\mathcal{F} \, dL = -E\epsilon A L \, d\epsilon$$

$$\therefore W = -AEL \int_1^2 \epsilon \, d\epsilon = -\frac{AEL}{2} (\epsilon_2^2 - \epsilon_1^2) \quad (3.22)$$

(f) Work Done in Changing the Area of a Surface Film A film on the surface of a liquid has a surface tension, which is a property of the liquid and the surroundings. The surface tension acts to make the surface area of the liquid a minimum. It has the unit of force per unit length. The work done on a homogeneous liquid film in changing its surface area by an infinitesimal amount dA is

$$dW = -\sigma dA$$

where σ is the surface tension (N/m).

$$\therefore W = -\int_1^2 \sigma dA \quad (3.23)$$

(g) Magnetization of a Paramagnetic Solid The work done per unit volume on a magnetic material through which the magnetic and magnetization fields are uniform is

$$dW = -HdI$$

$$\text{and } W_{1-2} = -\int_{I_1}^{I_2} HdI \quad (3.24)$$

where H is the field strength, and I is the component of the magnetization field in the direction of the field. The minus sign provides that an increase in magnetization (positive dI) involves negative work.

The following equations summarize the different forms of work transfer:

Displacement work

$$\text{(compressible fluid)} \quad W = \int_1^2 p dV$$

$$\text{Electrical work} \quad W = \int_1^2 E dC = \int_1^2 EI \, dt$$

$$\text{Shaft work} \quad W = \int_1^2 T d\theta$$

$$\text{Surface film} \quad W = -\int_1^2 \sigma dA \quad (3.25)$$

$$\text{Stretched wire} \quad W = -\int_1^2 \mathcal{F} dL$$

$$\text{Magnetised solid} \quad W = - \int_1^2 H dl$$

It may be noted in the above expressions that the work is equal to the integral of the product of an intensive property and the change in its related extensive property. These expressions are valid only for infinitesimally slow quasi-static processes.

There are some other forms of work which can be identified in processes that are not quasi-static, for example, the work done by shearing forces in a process involving friction in a viscous fluid.

3.5 Free Expansion with Zero Work Transfer

Work transfer is identified only at the boundaries of a system. It is a boundary phenomenon, and a form of energy in transit crossing the boundary. Let us consider a gas separated from the vacuum by a partition (Fig. 3.17). Let the partition be removed. The gas rushes to fill the entire volume. The expansion of a gas against vacuum is called *free expansion*. If we neglect the work associated with the removal of partition, and consider the gas and vacuum together as our system (Fig. 3.17a), there is no work transfer involved here, since no work crosses the system boundary, and hence

$$\int_1^2 \delta W = 0, \text{ although } \int_1^2 p dV \neq 0$$

If only the gas is taken as the system (Fig. 3.17), when the partition is removed there is a change in the volume of the gas, and one is tempted to calculate the work from the expression $\int_1^2 p dV$. However, this is not a quasistatic process, although the initial and final end states are in equilibrium. Therefore, the work cannot be calculated from this relation. The two end states can be located on the p - V diagram and these are joined by a dotted line (Fig. 3.17c) to indicate that the process had occurred. However, if the vacuum space is divided into a large number of small volumes by partitions and the partitions are removed one by one slowly (Fig. 3.17d), then every state passed through by the system is an equilibrium state and the work done can then be estimated from the relation $\int_1^2 p dV$ (Fig. 3.17e). Yet, in free expansion of a gas, there is no resistance to the fluid at the system boundary as the volume of the gas increases to fill up the vacuum space. Work is done by a system to overcome some resistance. Since vacuum does not offer any resistance, there is no work transfer involved in free expansion.

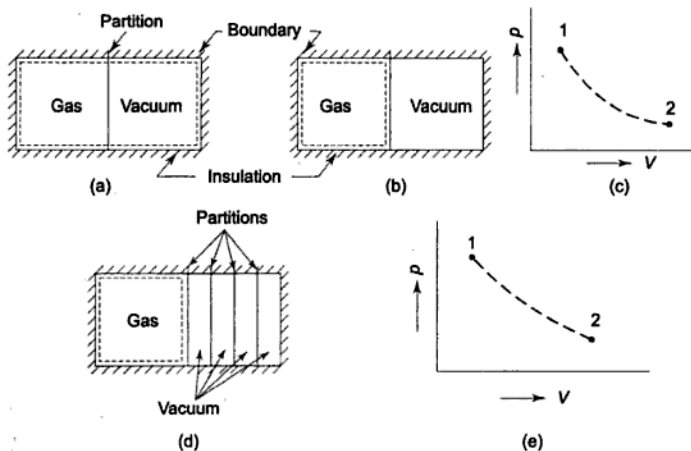

Fig. 3.17 Free expansion

3.6 Net Work Done by a System

Often different forms of a work transfer occur simultaneously during a process executed by a system. When all these work interactions have been evaluated, the total or net work done by the system would be equal to the algebraic sum of these as given below

$$W_{\text{total}} = W_{\text{displacement}} + W_{\text{shear}} + W_{\text{electrical}} + W_{\text{stirring}} + \dots$$

3.7 Heat Transfer

Heat is defined as the form of energy that is transferred across a boundary by virtue of a temperature difference. The temperature difference is the 'potential' or 'force' and heat transfer is the 'flux'.

The transfer of heat between two bodies in direct contact is called *conduction*. Heat may be transferred between two bodies separated by empty space or gases by the mechanism of *radiation* through electromagnetic waves. A third method of heat transfer is *convection* which refers to the transfer of heat between a wall and a fluid system in motion.

The direction of heat transfer is taken from the high temperature system to the low temperature system. *Heat flow into a system is taken to be positive, and heat flow out of a system is taken as negative* (Fig. 3.13). The symbol Q is used for heat transfer, i.e., the quantity of heat transferred within a certain time.

Heat is a form of energy in transit (like work transfer). It is a boundary phenomenon, since it occurs only at the boundary of a system. Energy transfer by virtue of temperature difference only is called heat transfer. All other energy interactions may be termed as work transfer.

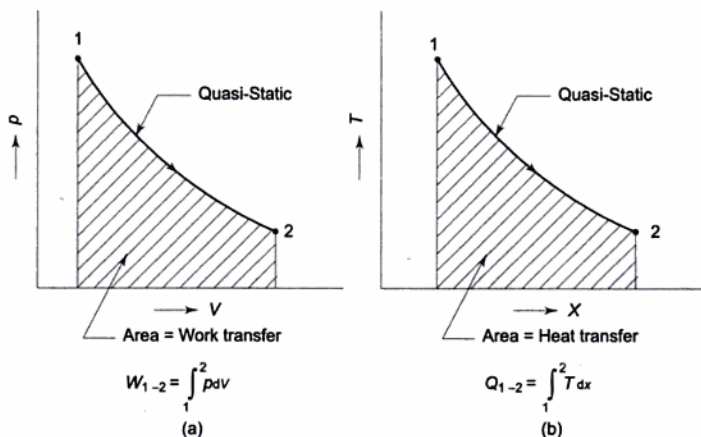

Fig. 3.19 Representation of work transfer and heat transfer in quasi-static processes on p - v and T - x coordinates

Just like displacement work, the heat transfer can also be written as the integral of the product of the intensive property T and the differential change of an extensive property, say X (Fig. 3.19b).

$$Q_{1-2} = \int_1^2 \delta Q = \int_1^2 T dX \quad (3.26)$$

It must also be valid for a quasi-static process only, and the heat transfer involved is represented by the area under the path 1-2 in T - X plot (Fig. 3.19b). Heat transfer is, therefore, a path function, i.e., the amount of heat transferred when a system changes from a state 1 to a state 2 depends on the path the system follows (Fig. 3.19b). Therefore, δQ is an inexact differential. Now,

$$\delta Q = T dX$$

where X is an extensive property and dX is an exact differential.

$$\therefore dX = \frac{1}{T} \delta Q \quad (3.27)$$

To make δQ integrable, i.e., an exact differential, it must be multiplied by an integrating factor which is, in this case, $1/T$. The extensive property X is yet to be defined. It has been introduced in Chapter 7 and it is called 'entropy'.

3.9 Specific Heat and Latent Heat

The *specific heat* of a substance is defined as the amount of heat required to raise a unit mass of the substance through a unit rise in temperature. The symbol c will be used for specific heat.

$$\therefore c = \frac{Q}{m \cdot \Delta t} \text{ J/kg K}$$

where Q is the amount of heat transfer (J), m , the mass of the substance (kg), and Δt , the rise in temperature (K).

Since heat is not a property, as explained later, so the specific heat is qualified with the process through which exchange of heat is made. For gases, if the process is at constant pressure, it is c_p , and if the process is at constant volume, it is c_v . For solids and liquids, however, the specific heat does not depend on the process. An elegant manner of defining specific heats, c_v and c_p , in terms of properties is given in Secs 4.5 and 4.6.

The product of mass and specific heat (mc) is called the *heat capacity* of the substance. The capital letter C , C_p or C_v , is used for heat capacity.

The latent heat is the amount of heat transfer required to cause a phase change in unit mass of a substance *at a constant pressure and temperature*. There are three phases in which matter can exist: solid, liquid, and vapour or gas. The *latent heat of fusion* (l_{fu}) is the amount of heat transferred to melt unit mass of solid into liquid, or to freeze unit mass of liquid to solid. The *latent heat of vaporization* (l_{vap}) is the quantity of heat required to vaporize unit mass of liquid into vapour, or condense unit mass of vapour into liquid. The *latent heat of sublimation* (l_{sub}) is the amount of heat transferred to convert unit mass of solid to vapour or vice versa. l_{fu} is not much affected by pressure, whereas l_{vap} is highly sensitive to pressure.

3.10 Points to Remember Regarding Heat Transfer and Work Transfer

- Heat transfer and work transfer are the *energy interactions*. A closed system and its surroundings can interact in two ways: by heat transfer and by work transfer. Thermodynamics studies how these interactions bring about property changes in a system.
- The same effect in a closed system can be brought about either by heat transfer or by work transfer. Whether heat transfer or work transfer has taken place depends on what constitutes the system.
- Both heat transfer and work transfer are boundary phenomena. Both are observed at the boundaries of the system, and both represent energy crossing the boundaries of the system.
- It is wrong to say 'total heat' or 'heat content' of a closed system, because heat or work is not a property of the system. Heat, like work, cannot be stored by the system. Both heat and work are the energy in transit.
- Heat transfer is the energy interaction due to temperature difference only. All other energy interactions may be termed as work transfer.
- Both heat and work are path functions and inexact differentials. The magnitude of heat transfer or work transfer depends upon the path the system follows during the change of state.

SOLVED EXAMPLES

Example 3.1 Gas from a bottle of compressed helium is used to inflate an inelastic flexible balloon, originally folded completely flat to a volume of 0.5 m^3 . If the barometer reads 760 mm Hg , what is the amount of work done upon the atmosphere by the balloon? Sketch the system before and after the process.

Solution The firm line P_1 (Fig. Ex. 3.1) shows the boundary of the system before the process, and the dotted line P_2 shows the boundary after the process. The displacement work

$$\begin{aligned} W_d &= \int_{\text{Balloon}} p dV + \int_{\text{Bottle}} p dV = p \Delta V + 0 \\ &= 101.325 \frac{\text{kN}}{\text{m}^2} \times 0.5 \text{ m}^3 \\ &= 50.66 \text{ kJ} \end{aligned}$$

This is positive because work is done by the system. Work done by the atmosphere is -50.66 kJ . Since the wall of the bottle is rigid, there is no $p dV$ -work involved in it.

It is assumed that the pressure in the balloon is atmospheric at all times, since the balloon fabric is light, inelastic and unstressed. If the balloon were elastic and stressed during the filling process, the work done by the gas would be greater than 50.66 kJ by an amount equal to the work done in stretching the balloon, although the displacement work done by the atmosphere is still -50.66 kJ . However, if the system includes both the gas and the balloon, the displacement work would be 50.66 kJ , as estimated above.

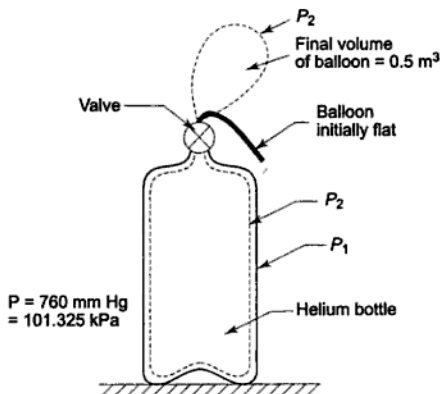

Fig. Ex. 3.1

Example 3.2 When the value of the evacuated bottle (Fig. Ex. 3.2) is opened, atmospheric air rushes into it. If the atmospheric pressure is 101.325 kPa, and 0.6 m^3 of air (measured at atmospheric conditions) enters into the bottle, calculate the work done by air.

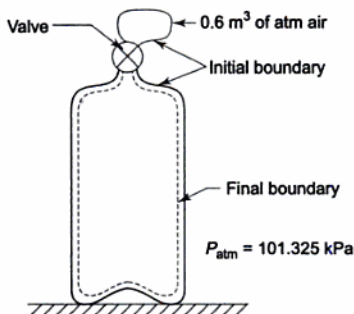

Fig. Ex. 3.2

Solution The displacement work done by air

$$\begin{aligned}
 W_d &= \int_{\text{Bottle}} p dV + \int_{\text{Free-air boundary}} p dV \\
 &= 0 + p \Delta V \\
 &= 101.325 \text{ kN/m}^2 \times 0.6 \text{ m}^3 \\
 &= 60.8 \text{ kJ}
 \end{aligned}$$

Since the free-air boundary is contracting, the work done by the system is negative (ΔV being negative), and the surroundings do positive work upon the system.

Example 3.3 A piston and cylinder machine containing a fluid system has a stirring device in the cylinder (Fig. Ex. 3.3). The piston is frictionless, and it is held down against the fluid due to the atmospheric pressure of 101.325 kPa. The stirring device is turned 10,000 revolutions with an average torque against the fluid of 1.275 mN. Meanwhile the piston of 0.6 m diameter moves out 0.8 m. Find the net work transfer for the system.

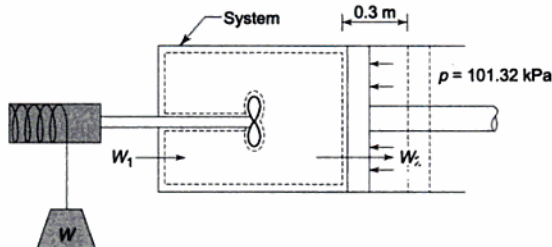

Fig. Ex. 3.3

Solution Work done by the stirring device upon the system (Fig. Ex. 3.3).

$$\begin{aligned}W_1 &= 2\pi TN \\ &= 2\pi \times 1.275 \times 10,000 \text{ Nm} \\ &= 80 \text{ kJ}\end{aligned}$$

This is negative work for the system.

Work done by the system upon the surroundings

$$\begin{aligned}W_2 &= (pA) \cdot L \\ &= 101.325 \frac{\text{kN}}{\text{m}^2} \times \frac{\pi}{4} (0.6)^2 \text{ m}^2 \times 0.80 \text{ m} \\ &= 22.9 \text{ kJ}\end{aligned}$$

This is positive work for the system. Hence, the net work transfer for the system

$$W = W_1 + W_2 = -80 + 22.9 = -57.1 \text{ kJ}$$

Example 3.4 The following data refer to a 12-cylinder, single-acting, two-stroke marine diesel engine:

Speed—150 rpm

Cylinder diameter—0.8 m

Stroke of piston—1.2 m

Area of indicator diagram— $5.5 \times 10^{-4} \text{ m}^2$

Length of diagram—0.06 m

Spring value—147 MPa per m

Find the net rate of work transfer from the gas to the pistons in kW.

Solution Mean effective pressure, p_m , is given by

$$\begin{aligned}p_m &= \frac{a_d}{l_d} \times \text{spring constant} \\ &= \frac{5.5 \times 10^{-4} \text{ m}^2}{0.06} \times 147 \frac{\text{MPa}}{\text{m}} \\ &= 1.35 \text{ MPa}\end{aligned}$$

One engine cycle is completed in two strokes of the piston or one revolution of the crank-shaft.

∴ Work done in one minute

$$\begin{aligned}&= p_m LAN \\ &= 1.35 \times \frac{\pi}{4} (0.8)^2 \times 1.2 \times 150 = 122 \text{ MJ}\end{aligned}$$

Since the engine is single-acting, and it has 12 cylinders, each contributing an equal power, the rate of work transfer from the gas to the piston is given by

$$\begin{aligned}\dot{W} &= 122 \times 12 \text{ MJ/min} \\ &= 24.4 \text{ MJ/s} \\ &= 24.4 \text{ MW} = 24,400 \text{ kW}\end{aligned}$$

Ans.

Example 3.5 It is required to melt 5 tonnes/h of iron from a charge at 15°C to molten metal at 1650°C. The melting point is 1535°C, and the latent heat is 270 kJ/kg. The specific heat in solid state is 0.502 and in liquid state (29.93/atomic weight) kJ/kg K. If an electric furnace has 70% efficiency, find the kW rating needed. If the density in molten state is 6900 kg/m³ and the bath volume is three times the hourly melting rate, find the dimensions of the cylindrical furnace if the length to diameter ratio is 2. The atomic weight of iron is 56.

Solution Heat required to melt 1 kg of iron at 15°C to molten metal at 1650°C
 = Heat required to raise the temperature from 15°C to 1535°C
 + Latent heat + Heat required to raise the temperature from 1535°C to 1650°C
 = 0.502 (1535 - 15) + 270 + 29.93 (1650 - 1535)/56
 = 763 + 270 + 61.5
 = 1094.5 kJ/kg

Melting rate = 5×10^3 kg/h

So, the rate of heat supply required

$$= (5 \times 10^3 \times 1094.5) \text{ kJ/h}$$

Since the furnace has 70% efficiency, the rating of the furnace would be

$$= \frac{\text{Rate of heat supply per second}}{\text{Furnace efficiency}}$$

$$= \frac{5 \times 10^3 \times 1094.5}{0.7 \times 3600} = 217 \times 10^3 \text{ kW} \quad \text{Ans.}$$

$$\text{Volume needed} = \frac{3 \times 5 \times 10^3}{6900} \text{ m}^3 = 2.18 \text{ m}^3$$

If d is the diameter and l the length of the furnace

$$\frac{\pi}{4} d^2 l = 218 \text{ m}^3$$

or $\frac{\pi}{4} d^2 \times 2d = 218 \text{ m}^3$

$\therefore d = 1.15 \text{ m}$

and $l = 2.30 \text{ m}$ Ans.

Example 3.6 If it is desired to melt aluminium with solid state specific heat 0.9 kJ/kgK, latent heat 390 kJ/kg, atomic weight 27, density in molten state 2400 kg/m³ and final temperature 700°C, find out how much metal can be melted per hour with the above kW rating. Other data are as in the above example. Also, find the mass of aluminium that the above furnace will hold. The melting point of aluminium is 660°C.

Solution Heat required per kg of aluminium

$$\begin{aligned}
 &= 0.9(660 - 15) + 390 + \frac{29.93}{27}(700 - 660) \\
 &= 580.5 + 390 + 44.3 \\
 &= 1014.8 \text{ kJ}
 \end{aligned}$$

$$\text{Heat to be supplied} = \frac{1014.8}{0.7} = 1449.7 \text{ kJ/kg}$$

With the given power, the rate at which aluminium can be melted

$$\begin{aligned}
 &= \frac{2.17 \times 10^3 \times 3600}{1449.7} \text{ kg/h} \\
 &= 5.39 \text{ tonnes/h}
 \end{aligned}$$

Ans.

Mass of aluminium that can be held in the above furnace

$$\begin{aligned}
 &= 2.18 \times 2400 \text{ kg} \\
 &= 5.23 \text{ tonnes}
 \end{aligned}$$

Ans.

REVIEW QUESTIONS

- 3.1 How can a closed system and its surroundings interact? What is the effect of such interactions on the system?
- 3.2 When is work said to be done by a system?
- 3.3 What are positive and negative work interactions?
- 3.4 What is displacement work?
- 3.5 Under what conditions is the work done equal to $\int_1^2 p dV$?
- 3.6 What do you understand by path function and point function? What are exact and inexact differentials?
- 3.7 Show that work is a path function, and not a property.
- 3.8 What is an indicator diagram?
- 3.9 What is mean effective pressure? How is it measured?
- 3.10 What are the indicated power and the brake power of an engine?
- 3.11 How does the current flowing through a resistor represent work transfer?
- 3.12 What do you understand by flow work? Is it different from displacement work?
- 3.13 Why does free expansion have zero work transfer?
- 3.14 What is heat transfer? What are its positive and negative directions?
- 3.15 What are adiabatic and diathermic walls?
- 3.16 What is an integrating factor?
- 3.17 Show that heat is a path function and not a property.
- 3.18 What is the difference between work transfer and heat transfer?
- 3.19 Does heat transfer inevitably cause a temperature rise?

PROBLEMS

- 3.1 (a) A pump forces $1 \text{ m}^3/\text{min}$ of water horizontally from an open well to a closed tank where the pressure is 0.9 MPa . Compute the work the pump must do upon the water in an hour just to force the water into the tank against the pressure. Sketch the system upon which the work is done before and after the process.

Ans. 13.31 kJ

- (b) If the work done as above upon the water had been used solely to raise the same amount of water vertically against gravity without change of pressure, how many meters would the water have been elevated?
- (c) If the work done in (a) upon the water had been used solely to accelerate the water from zero velocity without change of pressure or elevation, what velocity would the water have reached? If the work had been used to accelerate the water from an initial velocity of 10 m/s , what would the final velocity have been?
- 3.2 The piston of an oil engine, of area 0.0045 m^2 , moves downwards 75 mm , drawing in 0.00028 m^3 of fresh air from the atmosphere. The pressure in the cylinder is uniform during the process at 80 kPa , while the atmospheric pressure is 101.325 kPa , the difference being due to the flow resistance in the induction pipe and the inlet valve. Estimate the displacement work done by the air finally in the cylinder.

Ans. 27 J

- 3.3 An engine cylinder has a piston of area 0.12 m^2 and contains gas at a pressure of 1.5 MPa . The gas expands according to a process which is represented by a straight line on a pressure-volume diagram. The final pressure is 0.15 MPa . Calculate the work done by the gas on the piston if the stroke is 0.30 m .

Ans. 29.7 kJ

- 3.4 A mass of 1.5 kg of air is compressed in a quasi-static process from 0.1 MPa to 0.7 MPa for which $pv = \text{constant}$. The initial density of air is 1.16 kg/m^3 . Find the work done by the piston to compress the air.

Ans. 251.62 kJ

- 3.5 A mass of gas is compressed in a quasi-static process from 80 kPa , 0.1 m^3 to 0.4 MPa , 0.03 m^3 . Assuming that the pressure and volume are related by $pv^n = \text{constant}$, find the work done by the gas system.

Ans. -11.83 kJ

- 3.6 A single-cylinder, double-acting, reciprocating water pump has an indicator diagram which is a rectangle 0.075 m long and 0.05 m high. The indicator spring constant is 147 MPa per m . The pump runs at 50 rpm . The pump cylinder diameter is 0.15 m and the piston stroke is 0.20 m . Find the rate in kW at which the piston does work on the water.

Ans. 43.3 kW

- 3.7 A single-cylinder, single-acting, 4 stroke engine of 0.15 m bore develops an indicated power of 4 kW when running at 216 rpm . Calculate the area of the indicator diagram that would be obtained with an indicator having a spring constant of $25 \times 10^6 \text{ N/m}^3$. The length of the indicator diagram is 0.1 times the length of the stroke of the engine.

Ans. 505 mm^2

- 3.8 A six-cylinder, 4-stroke gasoline engine is run at a speed of 2520 RPM. The area of the indicator card of one cylinder is $2.45 \times 10^3 \text{ mm}^2$ and its length is 58.5 mm. The spring constant is $20 \times 10^6 \text{ N/m}^3$. The bore of the cylinders is 140 mm and the piston stroke is 150 mm. Determine the indicated power, assuming that each cylinder contributes an equal power.

Ans. 243.57 kW

- 3.9 A closed cylinder of 0.25 m diameter is fitted with a light frictionless piston. The piston is retained in position by a catch in the cylinder wall and the volume on one side of the piston contains air at a pressure of 750 kN/m^2 . The volume on the other side of the piston is evacuated. A helical spring is mounted coaxially with the cylinder in this evacuated space to give a force of 120 N on the piston in this position. The catch is released and the piston travels along the cylinder until it comes to rest after a stroke of 1.2 m. The piston is then held in its position of maximum travel by a ratchet mechanism. The spring force increases linearly with the piston displacement to a final value of 5 kN. Calculate the work done by the compressed air on the piston.

Ans. 3.07 kJ

- 3.10 A steam turbine drives a ship's propeller through an 8 : 1 reduction gear. The average resisting torque imposed by the water on the propeller is $750 \times 10^3 \text{ N}$ and the shaft power delivered by the turbine to the reduction gear is 15 MW. The turbine speed is 1450 rpm. Determine (a) the torque developed by the turbine, (b) the power delivered to the propeller shaft, and (c) the net rate of working of the reduction gear.

Ans. (a) $T = 98.84 \text{ km N}$, (b) 14.235 MW, (c) 0.765 MW

- 3.11 A fluid, contained in a horizontal cylinder fitted with a frictionless leakproof piston, is continuously agitated by means of a stirrer passing through the cylinder cover. The cylinder diameter is 0.40 m. During the stirring process lasting 10 minutes, the piston slowly moves out a distance of 0.485 m against the atmosphere. The net work done by the fluid during the process is 2 kJ. The speed of the electric motor driving the stirrer is 840 rpm. Determine the torque in the shaft and the power output of the motor.

Ans. 0.08 mN, 6.92 W

- 3.12 At the beginning of the compression stroke of a two-cylinder internal combustion engine the air is at a pressure of 101.325 kPa. Compression reduces the volume to 1/5 of its original volume, and the law of compression is given by $p v^{1.2} = \text{constant}$. If the bore and stroke of each cylinder is 0.15 m and 0.25 m, respectively, determine the power absorbed in kW by compression strokes when the engine speed is such that each cylinder undergoes 500 compression strokes per minute.

Ans. 17.95 kW

- 3.13 Determine the total work done by a gas system following an expansion process as shown in Fig. P. 3.13.

Ans. 2952 MJ

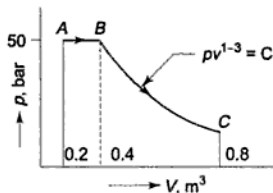

Fig. P. 3.13

- 3.14 A system of volume V contains a mass m of gas at pressure p and temperature T . The macroscopic properties of the system obey the following relationship:

$$\left(p + \frac{a}{V^2}\right)(V - b) = mRT$$

where a , b , and R are constants.

Obtain an expression for the displacement work done by the system during a constant-temperature expansion from volume V_1 to volume V_2 . Calculate the work done by a system which contains 10 kg of this gas expanding from 1 m^3 to 10 m^3 at a temperature of 293 K. Use the values $a = 15.7 \times 10^4 \text{ Nm}^4$, $b = 1.07 \times 10^{-2} \text{ m}^3$, and $R = 0.278 \text{ kJ/kg-K}$.

Ans. 1742.14 kJ

- 3.15 If a gas of volume 6000 cm^3 and at a pressure of 100 kPa is compressed quasistatically according to $pV^2 = \text{constant}$ until the volume becomes 2000 cm^3 , determine the final pressure and the work transfer.

Ans. 900 kPa, 1.2 kJ

- 3.16 The flow energy of $0.124 \text{ m}^3/\text{min}$ of a fluid crossing a boundary to a system is 18 kW. Find the pressure at this point.

Ans. 764 kPa

- 3.17 A milk chilling unit can remove heat from the milk at the rate of 41.87 MJ/h. Heat leaks into the milk from the surroundings at an average rate of 4.187 MJ/h. Find the time required for cooling a batch of 500 kg of milk from 45°C to 5°C . Take the c_p of milk to be 4.187 kJ/kgK.

- 3.18 680 kg of fish at 5°C are to be frozen and stored at -12°C . The specific heat of fish above freezing point is 3.182, and below freezing point is 1.717 kJ/kgK. The freezing point is -2°C . and the latent heat of fusion is 234.5 kJ/kg. How much heat must be removed to cool the fish, and what per cent of this is latent heat?

Ans. 186.28 MJ, 85.6%

- 3.19 A horizontal cylinder fitted with a sliding piston contains 0.1 m^3 of a gas at a pressure of 1 atm. The piston is restrained by a linear spring. In the initial state, the gas pressure inside the cylinder just balances the atmospheric pressure of 1 atm on the outside of the piston and the spring exerts no force on the piston. The gas is then heated reversibly until its volume and pressure become 0.16 m^3 and 2 atm, respectively. (a) Write the equation for the relation between the pressure and volume of the gas. (b) Calculate the work done by the gas. (c) Of the total work done by the gas, how much is done against the atmosphere? How much is done against the spring?

Ans. (a) $p \text{ (N/m}^2\text{)} = 2.026 \times 10^6 V - 1.013 \times 10^5$

(b) 7,598 J, (c) 5,065 J, 2,533 J

- 3.20 An elastic sphere initially has a diameter of 1 m and contains a gas at a pressure of 1 atm. Due to heat transfer the diameter of the sphere increases to 1.1 m. During the heating process the gas pressure inside the sphere is proportional to the sphere diameter. Calculate the work done by the gas.

Ans. 18.4 kJ

- 3.21 A piston-cylinder device contains 0.05 m^3 of a gas initially at 200 kPa. At this state, a linear spring having a spring constant of 150 kN/m is touching the piston but exerting no force on it. Now heat is transferred to the gas, causing the piston to rise and to compress the spring until the volume inside the cylinder doubles. If the cross-sectional area of the piston is 0.25 m^2 , determine (a) the final pressure

inside the cylinder, (b) the total work done by the gas, and (c) the fraction of this work done against the spring to compress it.

Ans. (a) 320 kPa, (b) 13 kJ, (c) 3 kJ

- 3.22 A piston-cylinder device, whose piston is resting on a set of stops, initially contains 3 kg of air at 200 kPa and 27°C. The mass of the piston is such that a pressure of 400 kPa is required to move it. Heat is now transferred to the air until its volume doubles. Determine the work done by the air and the total heat transferred to the air.

Ans. 516 kJ, 2674 kJ

4

First Law of Thermodynamics

Energy can be in two forms: (a) energy in *transit*, like heat and work transfer observed at the boundaries of a system, and (b) energy in *storage*, where energy is stored either *macroscopically* by virtue of motion, position or configuration of the system, or *microscopically* in the molecules or atoms constituting the system.

4.1 First Law for a Closed System Undergoing a Cycle

The transfer of heat and the performance of work may both cause the same effect in a system. Heat and work are different forms of the same entity, called energy, which is conserved. Energy which enters a system as heat may leave the system as work, or energy which enters the system as work may leave as heat.

Let us consider a closed system which consists of a known mass of water contained in an adiabatic vessel having a thermometer and a paddle wheel, as shown in Fig. 4.1. Let a certain amount of work W_{1-2} be done upon the system by the paddle wheel. The quantity of work can be measured by the fall of weight which drives the paddle wheel through a pulley. The system was initially at temperature t_1 , the same as that of atmosphere, and after work transfer let the temperature rise to t_2 . The pressure is always 1 atm. The process 1-2 undergone by the system is shown in Fig. 4.2 in generalized thermodynamic coordinates X , Y . Let the insulation now be removed. The system and the surroundings interact by heat transfer till the system returns to the original temperature t_1 , attaining the condition of thermal equilibrium with the atmosphere. The amount of heat transfer Q_{2-1} from the system during this process, 2-1, shown in Fig. 4.2, can be estimated. The system thus executes a cycle, which consists of a definite amount of work input W_{1-2} to the system followed by the transfer of an amount of heat Q_{2-1} from the system. It has been found that this W_{1-2} is always proportional to the heat Q_{2-1} , and the constant of proportionality is called the Joule's equivalent

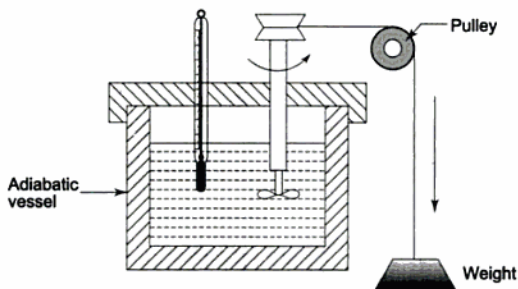

Fig. 4.1 Adiabatic work

or the *mechanical equivalent of heat*. In the simple example given here, there are only two energy transfer quantities as the system performs a thermodynamic cycle. If the cycle involves many more heat and work quantities, the same result will be found. Expressed algebraically,

$$(\Sigma W)_{\text{cycle}} = J (\Sigma Q)_{\text{cycle}} \quad (4.1)$$

where J is the Joule's equivalent. This is also expressed in the form

$$\oint dW = J \oint dQ$$

where the symbol \oint denotes the cyclic integral for the closed path. This is the *first law for a closed system undergoing a cycle*. It is accepted as a *general law of nature*, since no violation of it has ever been demonstrated.

In the S.I. system of units, both heat and work are measured in the derived unit of energy, the Joule. The constant of proportionality, J , is therefore unity ($J = 1 \text{ Nm/J}$).

The first law of thermodynamics owes much to J.P. Joule who, during the period 1840–1849, carried out a series of experiments to investigate the equivalence of work and heat. In one of these experiments, Joule used an apparatus similar to the one shown in Fig. 4.1. Work was transferred to the

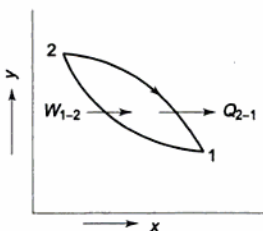

Fig. 4.2 Cycle completed by a system with two energy interactions: adiabatic work transfer $W_{1,2}$ followed by heat transfer $Q_{2,1}$

measured mass of water by means of a paddle wheel driven by the falling weight. The rise in the temperature of water was recorded. Joule also used mercury as the fluid system, and later a solid system of metal blocks which absorbed work by friction when rubbed against each other. Other experiments involved the supplying of work in an electric current. In every case, he found the same ratio (J) between the amount of work and the quantity of heat that would produce identical effects in the system.

Prior to Joule, heat was considered to be an invisible fluid flowing from a body of higher calorie to a body of lower calorie, and this was known as the *caloric theory of heat*. It was Joule who first established that heat is a form of energy, and thus laid the foundation of the first law of thermodynamics.

4.2 First Law for a Closed System Undergoing a Change of State

The expression $(\Sigma W)_{\text{cycle}} = (\Sigma Q)_{\text{cycle}}$ applies only to systems undergoing cycles, and the algebraic summation of all energy transfer across system boundaries is zero. But if a system undergoes a change of state during which both heat transfer and work transfer are involved, the *net* energy transfer will be stored or accumulated within the system. If Q is the amount of heat transferred to the system and W is the amount of work transferred from the system during the process (Fig. 4.3), the net energy transfer ($Q - W$) will be stored in the system. Energy in storage is neither heat nor work, and is given the name *internal energy* or simply, the *energy* of the system.

$$\text{Therefore} \quad Q - W = \Delta E$$

where ΔE is the increase in the energy of the system

$$\text{or} \quad Q = \Delta E + W \quad (4.2)$$

Here Q , W , and ΔE are all expressed in the same units (in joules). Energy may be stored by a system in different modes, as explained in Article 4.4.

If there are more energy transfer quantities involved in the process, as shown in Fig. 4.4, the first law gives

$$(Q_2 + Q_3 - Q_1) = \Delta E + (W_2 + W_3 - W_1 - W_4)$$

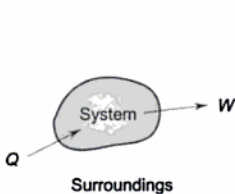

Fig. 4.3 Heat and work interactions of a system with its surroundings in a process

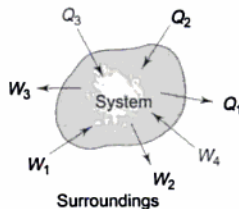

Fig. 4.4 System-surroundings interaction in a process involving many energy fluxes

Energy is thus conserved in the operation. The first law is a particular formulation of the principle of the conservation of energy. Equation (4.2) may also be considered as the definition of energy. This definition does not give an absolute value of energy E , but only the change of energy ΔE for the process. It can, however, be shown that the energy has a definite value at every state of a system and is, therefore, a property of the system.

4.3 Energy—A Property of the System

Consider a system which changes its state from state 1 to state 2 by following the path A , and returns from state 2 to state 1 by following the path B (Fig. 4.5). So the system undergoes a cycle. Writing the first law for path A

$$Q_A = \Delta E_A + W_A \quad (4.3)$$

and for path B

$$Q_B = \Delta E_B + W_B \quad (4.4)$$

The processes A and B together constitute a cycle, for which

$$(\Sigma W)_{\text{cycle}} = (\Sigma Q)_{\text{cycle}}$$

$$\text{or } W_A + W_B = Q_A + Q_B$$

$$\text{or } Q_A - W_A = W_B - Q_B \quad (4.5)$$

From equations (4.3), (4.4), and (4.5), it yields

$$\Delta E_A = -\Delta E_B \quad (4.6)$$

Similarly, had the system returned from state 2 to state 1 by following the path C instead of path B

$$\Delta E_A = -\Delta E_C \quad (4.7)$$

From equations (4.6) and (4.7)

$$\Delta E_B = \Delta E_C \quad (4.8)$$

Therefore, it is seen that the change in energy between two states of a system is the same, whatever path the system may follow in undergoing that change of state. If some arbitrary value of energy is assigned to state 2, the value of energy at state 1 is fixed independent of the path the system follows. Therefore, energy has a definite value for every state of the system. Hence, it is a *point function and a property of the system*.

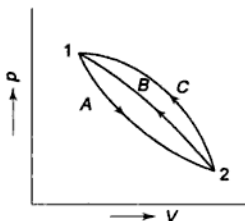

Fig. 4.5 Energy—a property of a system

The energy E is an extensive property. The *specific energy*, $e = E/m$ (J/kg), is an intensive property.

The cyclic integral of any property is zero, because the final state is identical with the initial state. $\oint dE = 0$, $\oint dV = 0$, etc. So for a cycle, the equation (4.2) reduces to equation (4.1).

4.4 Different Forms of Stored Energy

The symbol E refers to the total energy stored in a system. Basically there are two modes in which energy may be stored in a system:

- (a) Macroscopic energy mode
- (b) Microscopic energy mode

The macroscopic energy mode includes the macroscopic kinetic energy and potential energy of a system. Let us consider a fluid element of mass m having the centre of mass velocity \bar{V} (Fig. 4.6). The macroscopic kinetic energy E_K of the fluid element by virtue of its motion is given by

$$E_K = \frac{m\bar{V}^2}{2}$$

If the elevation of the fluid element from an arbitrary datum is z , then the macroscopic potential energy E_p by virtue of its position is given by

$$E_p = mgz$$

The microscopic energy mode refers to the energy stored in the molecular and atomic structure of the system, which is called the *molecular internal energy* or *simply internal energy*, customarily denoted by the symbol U . Matter is composed of molecules. Molecules are in random thermal motion (for a gas) with an average velocity \bar{v} , constantly colliding with one another and with the walls (Fig. 4.6). Due to a collision, the molecules may be subjected to rotation as well

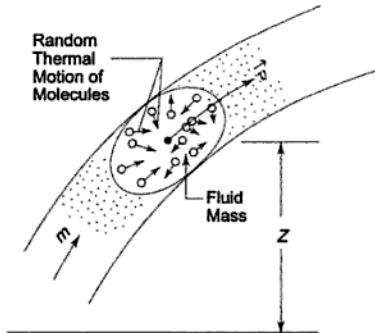

Fig. 4.6 Macroscopic and microscopic energy

as vibration. They can have translational kinetic energy, rotational kinetic energy, vibrational energy, electronic energy, chemical energy and nuclear energy (Fig. 4.7). If ϵ represents the energy of one molecule, then

$$\epsilon = \epsilon_{\text{trans}} + \epsilon_{\text{rot}} + \epsilon_{\text{vib}} + \epsilon_{\text{chem}} + \epsilon_{\text{electronic}} + \epsilon_{\text{nuclear}} \quad (4.9)$$

If N is the total number of molecules in the system, then the total internal energy

$$U = N\epsilon \quad (4.10)$$

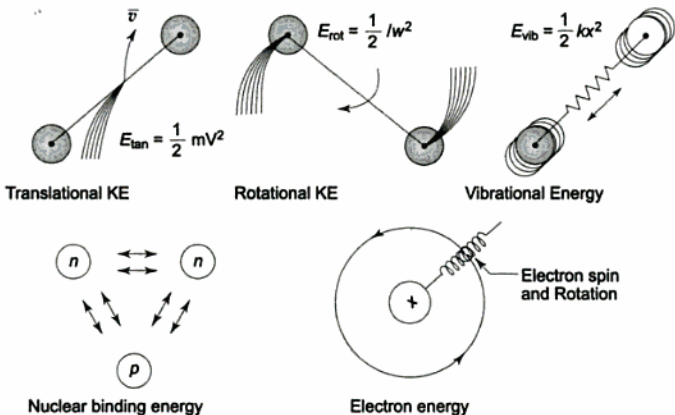

Fig. 4.7 Various components of internal energy stored in a molecule

In an ideal gas there are no intermolecular forces of attraction and repulsion, and the internal energy depends only on temperature. Thus

$$U = f(T) \text{ only} \quad (4.11)$$

for an ideal gas

Other forms of energy which can also be possessed by a system are magnetic energy, electrical energy and surface (tension) energy. In the absence of these forms, the total energy E of a system is given by

$$E = \underbrace{E_K + E_P}_{\text{macro}} + \underbrace{U}_{\text{micro}} \quad (4.12)$$

where E_K , E_P , and U refer to the kinetic, potential and internal energy, respectively. In the absence of motion and gravity

$$E_K = 0, E_P = 0$$

$$E = U$$

and equation (4.2) becomes

$$Q = \Delta U + W \quad (4.13)$$

U is an extensive property of the system. The specific internal energy u is equal to U/m and its unit is J/kg.

In the differential forms, equations (4.2) and (4.13) become

$$\delta Q = dE + \delta W \quad (4.14)$$

$$\delta Q = \delta U + \delta W \quad (4.15)$$

where

$$\delta W = \delta W_{pdV} + \delta W_{\text{shaft}} + \delta W_{\text{electrical}} + \dots,$$

considering the different forms of work transfer which may be present. When only pdV work is present, the equations become

$$\delta Q = dE + pdV \quad (4.16)$$

$$\delta Q = dU + pdV \quad (4.17)$$

or, in the integral form

$$Q = \Delta E + \int pdV \quad (4.18)$$

$$Q = \Delta U + \int pdV \quad (4.19)$$

4.5 Specific Heat at Constant Volume

The specific heat of a substance at constant volume c_v is defined as the rate of change of specific internal energy with respect to temperature when the volume is held constant, i.e.

$$c_v = \left(\frac{\partial u}{\partial T} \right)_v \quad (4.20)$$

For a constant-volume process

$$(\Delta u)_v = \int_{T_1}^{T_2} c_v \cdot dT \quad (4.21)$$

The first law may be written for a closed stationary system composed of a unit mass of a pure substance

$$Q = \Delta u + W$$

or

$$\delta Q = du + \delta W$$

For a process in the absence of work other than pdV work

$$\delta W = p \delta V$$

\therefore

$$\delta Q = du + p \delta v \quad (4.22)$$

When the volume is held constant

$$(Q)_v = (\Delta u)_v$$

\therefore

$$(Q)_v = \int_{T_1}^{T_2} c_v dT \quad (4.23)$$

Heat transferred at constant volume increases the internal energy of the system. If the specific heat of a substance is defined in terms of heat transfer, then

$$c_v = \left(\frac{\partial Q}{\partial T} \right)_v$$

Since Q is not a property, this definition does not imply that c_v is a property of a substance. Therefore, this is not the appropriate method of defining the specific heat, although $(dQ)_v = du$.

Since u , T , and v are properties, c_v is a property of the system. The product $mc_v = C_v$ is called the *heat capacity at constant volume* (J/K).

4.6 Enthalpy

The enthalpy of a substance, h , is defined as

$$h = u + pv \quad (4.24)$$

It is an intensive property of a system (kJ/kg).

Internal energy change is equal to the heat transferred in a constant volume process involving no work other than pdV work. From equation (4.22), it is possible to derive an expression for the heat transfer in a constant pressure process involving no work other than pdV work. In such a process in a closed stationary system of unit mass of a pure substance

$$dQ = du + pdv$$

At constant pressure

$$pdv = d(pv)$$

$$\therefore (dQ)_p = du + d(pv)$$

$$\text{or} \quad (dQ)_p = d(u + pv)$$

$$\text{or} \quad (dQ)_p = dh \quad (4.25)$$

where $h = u + pv$ is the *specific enthalpy*, a property of the system.

Heat transferred at constant pressure increases the enthalpy of a system.

For an ideal gas, the enthalpy becomes

$$h = u + RT \quad (4.26)$$

Since the internal energy of an ideal gas depends only on the temperature (Eq. 4.11), the enthalpy of an ideal gas also depends on the temperature only, i.e.

$$h = f(T) \text{ only} \quad (4.27)$$

Total enthalpy $H = mh$

$$\text{Also} \quad H = U + pV$$

$$\text{and} \quad h = H/m \text{ (J/kg)}$$

4.7 Specific Heat at Constant Pressure

The specific heat at constant pressure c_p is defined as the rate of change of enthalpy with respect to temperature when the pressure is held constant

$$c_p = \left(\frac{\partial h}{\partial T} \right)_p \quad (4.28)$$

Since h , T and p are properties, so c_p is a property of the system. Like c_v , c_p should not be defined in terms of heat transfer of constant pressure, although $(dQ)_p = dh$.

For a constant pressure process

$$(\Delta h)_p = \int_{T_1}^{T_2} c_p \cdot dT \quad (4.29)$$

The first law for a closed stationary system of unit mass

$$\begin{aligned} \text{Again} \quad dQ &= du + pdv \\ h &= u + pv \\ \therefore dh &= du + pdV + vdp \\ &= dQ + vdp \\ \therefore dQ &= dh - vdp \\ \therefore (dQ)_p &= dh \\ \text{or} \quad (Q)_p &= (\Delta h)_p \\ \therefore \text{From equations (4.19) and (4.20)} \end{aligned} \quad (4.30)$$

$$(Q)_p = \int_{T_1}^{T_2} c_p dT$$

c_p is a property of the system, just like c_v . The *heat capacity at constant pressure* C_p is equal to mc_p (J/K).

4.8 Energy of an Isolated System

An isolated system is one in which there is no interaction of the system with the surroundings. For an isolated system, $dQ = 0$, $dW = 0$.

The first law gives

$$dE = 0$$

$$\text{or} \quad E = \text{constant}$$

The energy of an isolated system is always constant.

4.9 Perpetual Motion Machine of the First Kind—PMM1

The first law states the general principle of the conservation of energy. *Energy is neither created nor destroyed, but only gets transformed from one form to another.* There can be no machine which would continuously supply mechanical work without some other form of energy disappearing simultaneously (Fig. 4.8). Such a *fictitious machine* is called a *perpetual motion machine of the first kind*, or in brief, PMM1. *A PMM1 is thus impossible.*

The converse of the above statement is also true, i.e., there can be no machine which would continuously consume work without some other form of energy appearing simultaneously (Fig. 4.9).

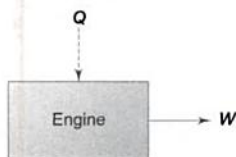

Fig. 4.8 A PMMI

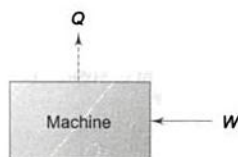

Fig. 4.9 The converse of PMMI

4.10 Limitations of the First Law

The first law deals with the amounts of energy of various forms transferred between the system and its surroundings and with changes in the energy stored in the system. It treats work and heat interactions as equivalent forms of energy in transit and does not indicate the possibility of a spontaneous process proceeding in a certain direction. It is the second law which assigns a quality to different forms of energy, and also indicates the direction of any spontaneous process.

SOLVED EXAMPLES

Example 4.1 A stationary mass of gas is compressed without friction from an initial state of 0.3 m^3 and 0.105 MPa to a final state of 0.15 m^3 and 0.105 MPa , the pressure remaining constant during the process. There is a transfer of 37.6 kJ of heat from the gas during the process. How much does the internal energy of the gas change?

Solution First law for a stationary system in a process gives

$$Q = \Delta U + W$$

$$\text{or} \quad Q_{1-2} = U_2 - U_1 + W_{1-2} \quad (1)$$

Here

$$\begin{aligned} W_{1-2} &= \int_{V_1}^{V_2} p dV = p(V_2 - V_1) \\ &= 0.105 (0.15 - 0.30) \text{ MJ} \\ &= -15.75 \text{ kJ} \\ Q_{1-2} &= -37.6 \text{ kJ} \end{aligned}$$

\therefore Substituting in equation (1)

$$-37.6 \text{ kJ} = U_2 - U_1 - 15.75 \text{ kJ}$$

$$\therefore \quad U_2 - U_1 = -21.85 \text{ kJ}$$

Ans.

The internal energy of the gas decreases by 21.85 kJ in the process.

Example 4.2 When a system is taken from state a to state b , in Fig. Ex. 4.2, along path acb , 84 kJ of heat flow into the system, and the system does 32 kJ of work. (a) How much will the heat that flows into the system along path adb be, if the work done is 10.5 kJ? (b) When the system is returned from b to a along the curved path, the work done on the system is 21 kJ. Does the system absorb or liberate heat, and how much of the heat is absorbed or liberated? (c) If $U_a = 0$ and $U_d = 42$ kJ, find the heat absorbed in the processes ad and db .

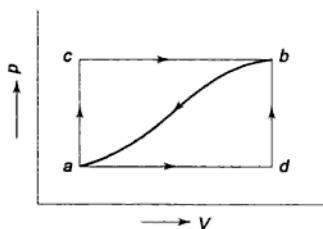

Fig. Ex. 4.2

Solution

$$Q_{acb} = 84 \text{ kJ}$$

$$W_{acb} = 32 \text{ kJ}$$

We have

$$Q_{acb} = U_b - U_a + W_{acb}$$

$$\therefore U_b - U_a = 84 - 32 = 52 \text{ kJ} \quad \text{Ans.}$$

$$(a) \quad Q_{adb} = U_b - U_a + W_{adb} \\ = 52 + 10.5$$

$$= 62.5 \text{ kJ} \quad \text{Ans.}$$

$$(b) \quad Q_{b-a} = U_a - U_b + W_{b-a} \\ = -52 - 21$$

$$= -73 \text{ kJ} \quad \text{Ans.}$$

The system liberates 73 kJ of heat.

$$(c) \quad W_{adb} = W_{ad} + W_{db} = W_{ad} = 10.5 \text{ kJ}$$

$$\therefore Q_{ad} = U_d - U_a + W_{ad} \\ = 42 - 0 + 10.5 = 52.5 \text{ kJ}$$

$$\text{Now } Q_{adb} = 62.5 \text{ kJ} = Q_{ad} + Q_{db}$$

$$\therefore Q_{db} = 62.5 - 52.5 = 10 \text{ kJ} \quad \text{Ans.}$$

Example 4.3 A piston and cylinder machine contains a fluid system which passes through a complete cycle of four processes. During a cycle, the sum of all heat transfers is -170 kJ. The system completes 100 cycles per min. Complete the

following table showing the method for each item, and compute the net rate of work output in kW.

Process	Q (kJ/min)	W (kJ/min)	ΔE (kJ/min)
a-b	0	2,170	—
b-c	21,000	0	—
c-d	-2,100	—	-36,600
d-a	—	—	—

Solution Process a-b:

$$Q = \Delta E + W$$

$$0 = \Delta E + 2170$$

\therefore

$$\Delta E = -2170 \text{ kJ/min}$$

Process b-c:

$$Q = \Delta E + W$$

$$21,000 = \Delta E + 0$$

\therefore

$$\Delta E = 21,000 \text{ kJ/min}$$

Process c-d:

$$Q = \Delta E + W$$

$$-2100 = -36,600 + W$$

\therefore

$$W = 34,500 \text{ kJ/min}$$

Process d-a:

$$\sum_{\text{cycle}} Q = -170 \text{ kJ}$$

The system completes 100 cycles/min.

$$\therefore Q_{ab} + Q_{bc} + Q_{cd} + Q_{da} = -17,000 \text{ kJ/min}$$

$$0 + 21,000 - 2,100 + Q_{da} = -17,000$$

\therefore

$$Q_{da} = -35,900 \text{ kJ/min}$$

Now $\oint dE = 0$, since cyclic integral of any property is zero.

$$\therefore \Delta E_{a-b} + \Delta E_{b-c} + \Delta E_{c-d} + \Delta E_{d-a} = 0$$

$$-2,170 + 21,000 - 36,600 + \Delta E_{d-a} = 0$$

\therefore

$$\Delta E_{d-a} = 17,770 \text{ kJ/min}$$

\therefore

$$\begin{aligned} W_{d-a} &= Q_{d-a} - \Delta E_{d-a} \\ &= -35,900 - 17,770 \\ &= -53,670 \text{ kJ/min} \end{aligned}$$

The table becomes

Process	Q (kJ/min)	W (kJ/min)	ΔE (kJ/min)
a-b	0	2,170	-2,170
b-c	21,000	0	21,000

c-d	- 2,100	34,500	- 36,600
d-a	- 35,900	- 53,670	17,770

Since

Rate of work output

$$\begin{aligned}\sum_{\text{cycle}} Q &= \sum_{\text{cycle}} W \\ &= -17,000 \text{ kJ/min} \\ &= -283.3 \text{ kW}\end{aligned}$$

Ans.

Example 4.4 The internal energy of a certain substance is given by the following equation

$$u = 3.56 pv + 84$$

where u is given in kJ/kg, p is in kPa, and v is in m^3/kg .

A system composed of 3 kg of this substance expands from an initial pressure of 500 kPa and a volume of 0.22 m^3 to a final pressure 100 kPa in a process in which pressure and volume are related by $pv^{1.2} = \text{constant}$.

- If the expansion is quasi-static, find Q , ΔU , and W for the process.
- In another process the same system expands according to the same pressure-volume relationship as in part (a), and from the same initial state to the same final state as in part (a), but the heat transfer in this case is 30 kJ. Find the work transfer for this process.
- Explain the difference in work transfer in parts (a) and (b).

Solution

$$\begin{aligned}\text{(a)} \quad u &= 3.56 pv + 84 \\ \Delta u &= u_2 - u_1 = 3.56 (p_2 v_2 - p_1 v_1) \\ \therefore \Delta U &= 3.56 (p_2 V_2 - p_1 V_1) \\ \text{Now } p_1 V_1^{1.2} &= p_2 V_2^{1.2} \\ \therefore V_2 &= V_1 \left(\frac{p_1}{p_2} \right)^{1/1.2} = 0.22 \left(\frac{5}{1} \right)^{1/1.2} \\ &= 0.22 \times 3.83 = 0.845 \text{ m}^3 \\ \therefore \Delta U &= 356 (1 \times 0.845 - 5 \times 0.22) \text{ kJ} \\ &= -356 \times 0.255 = -91 \text{ kJ} \quad \text{Ans. (a)}\end{aligned}$$

For a quasi-static process

$$\begin{aligned}W &= \int p dV = \frac{p_2 V_2 - p_1 V_1}{1 - n} \\ &= \frac{(1 \times 0.845 - 5 \times 0.22) 100}{1 - 1.2} = 127.5 \text{ kJ} \\ \therefore Q &= \Delta U + W \\ &= -91 + 127.5 = 36.5 \text{ kJ} \quad \text{Ans. (a)}\end{aligned}$$

(b) Here $Q = 30 \text{ kJ}$

Since the end states are the same, ΔU would remain the same as in (a).

$$\begin{aligned} \therefore W &= Q - \Delta U \\ &= 30 - (-91) \\ &= 121 \text{ kJ} \end{aligned}$$

Ans. (b)

(c) The work in (b) is not equal to $\int p dV$ since the process is not quasi-static.

Example 4.5 A fluid is confined in a cylinder by a spring-loaded, frictionless piston so that the pressure in the fluid is a linear function of the volume ($p = a + bV$). The internal energy of the fluid is given by the following equation

$$U = 34 + 3.15 pV$$

where U is in kJ, p in kPa, and V in cubic metre. If the fluid changes from an initial state of 170 kPa, 0.03 m^3 to a final state of 400 kPa, 0.06 m^3 , with no work other than that done on the piston, find the direction and magnitude of the work and heat transfer.

Solution The change in the internal energy of the fluid during the process.

$$\begin{aligned} U_2 - U_1 &= 3.15 (p_2 V_2 - p_1 V_1) \\ &= 315 (4 \times 0.06 - 1.7 \times 0.03) \\ &= 315 \times 0.189 = 59.5 \text{ kJ} \end{aligned}$$

Now

$$\begin{aligned} p &= a + bV \\ 170 &= a + b \times 0.03 \\ 400 &= a + b \times 0.06 \end{aligned}$$

From these two equations

$$\begin{aligned} a &= -60 \text{ kN/m}^2 \\ b &= 7667 \text{ kN/m}^5 \end{aligned}$$

Work transfer involved during the process

$$\begin{aligned} W_{1-2} &= \int_{V_1}^{V_2} p dV = \int_{V_1}^{V_2} (a + bV) dV \\ &= a(V_2 - V_1) + b \frac{V_2^2 - V_1^2}{2} \\ &= (V_2 - V_1) \left[a + \frac{b}{2} (V_1 + V_2) \right] \\ &= 0.03 \text{ m}^3 \left[-60 \text{ kN/m}^2 + \frac{7667}{2} \frac{\text{kN}}{\text{m}^5} \times 0.09 \text{ m}^3 \right] \\ &= 8.55 \text{ kJ} \end{aligned}$$

Work is done by the system, the magnitude being 8.55 kJ.

∴ Heat transfer involved is given by

$$\begin{aligned} Q_{1-2} &= U_2 - U_1 + W_{1-2} \\ &= 59.5 + 8.55 \\ &= 68.05 \text{ kJ} \end{aligned}$$

68.05 kJ of heat flow into the system during the process.

REVIEW QUESTIONS

- 4.1 State the first law for a closed system undergoing a cycle.
- 4.2 What was the contribution of J.P. Joule in establishing the first law?
- 4.3 What is the caloric theory of heat? Why was it rejected?
- 4.4 Which is the property introduced by the first law?
- 4.5 State the first law for a closed system undergoing a change of state.
- 4.6 Show that energy is a property of a system.
- 4.7 What are the modes in which energy is stored in a system?
- 4.8 Define internal energy. How is energy stored in molecules and atoms?
- 4.9 What is the difference between the standard symbols of E and U ?
- 4.10 What is the difference between heat and internal energy?
- 4.11 Define enthalpy. Why does the enthalpy of an ideal gas depend only on temperature?
- 4.12 Define the specific heats at constant volume and constant pressure.
- 4.13 Why should specific heat not be defined in terms of heat transfer?
- 4.14 Which property of a system increases when heat is transferred: (a) at constant volume, (b) at constant pressure?
- 4.15 What is a PMM1? Why is it impossible?

PROBLEMS

- 4.1 An engine is tested by means of a water brake at 1000 rpm. The measured torque of the engine is 10000 mN and the water consumption of the brake is $0.5 \text{ m}^3/\text{s}$, its inlet temperature being 20°C . Calculate the water temperature at exit, assuming that the whole of the engine power is ultimately transformed into heat which is absorbed by the cooling water.
Ans. 20.5°C
- 4.2 In a cyclic process, heat transfers are $+14.7 \text{ kJ}$, -25.2 kJ , -3.56 kJ and $+31.5 \text{ kJ}$. What is the net work for this cycle process?
Ans. 17.34 kJ
- 4.3 A slow chemical reaction takes place in a fluid at the constant pressure of 0.1 MPa . The fluid is surrounded by a perfect heat insulator during the reaction which begins at state 1 and ends at state 2. The insulation is then removed and 105 kJ of heat flow to the surroundings as the fluid goes to state 3. The following data are observed for the fluid at states 1, 2 and 3.

State	$V(\text{m}^3)$	$t(^\circ\text{C})$
1	0.003	20

2	0.3	370
3	0.06	20

For the fluid system, calculate E_2 and E_3 , if $E_1 = 0$

$$\text{Ans. } E_2 = -29.7 \text{ kJ, } E_3 = -110.7 \text{ kJ}$$

- 4.4 During one cycle the working fluid in an engine engages in two work interactions: 15 kJ to the fluid and 44 kJ from the fluid, and three heat interactions, two of which are known: 75 kJ to the fluid and 40 kJ from the fluid. Evaluate the magnitude and direction of the third heat transfer.

$$\text{Ans. } -6 \text{ kJ}$$

- 4.5 A domestic refrigerator is loaded with food and the door closed. During a certain period the machine consumes 1 kW h of energy and the internal energy of the system drops by 5000 kJ. Find the net heat transfer for the system.

$$\text{Ans. } -8.6 \text{ MJ}$$

- 4.6 1.5 kg of liquid having a constant specific heat of 2.5 kJ/kg K is stirred in a well-insulated chamber causing the temperature to rise by 15°C. Find ΔE and W for the process.

$$\text{Ans. } \Delta E = 56.25 \text{ kJ, } W = -56.25 \text{ kJ}$$

- 4.7 The same liquid as in Problem 4.6 is stirred in a conducting chamber. During the process 1.7 kJ of heat are transferred from the liquid to the surroundings, while the temperature of the liquid is rising by 15°C. Find ΔE and W for the process.

$$\text{Ans. } \Delta E = 56.25 \text{ kJ, } W = 57.95 \text{ kJ}$$

- 4.8 The properties of a certain fluid are related as follows

$$u = 196 + 0.718 t$$

$$pv = 0.287 (t + 273)$$

where u is the specific internal energy (kJ/kg), t is in °C, p is pressure (kN/m²), and v is specific volume (m³/kg).

For this fluid, find c_v and c_p

$$\text{Ans. } 0.718, 1.005 \text{ kJ/kg K}$$

- 4.9 A system composed of 2 kg of the above fluid expands in a frictionless piston and cylinder machine from an initial state of 1 MPa, 100°C to a final temperature of 30°C. If there is no heat transfer, find the net work for the process.

$$\text{Ans. } 100.52 \text{ kJ}$$

- 4.10 If all the work in the expansion of Problem 4.9 is done on the moving piston, show that the equation representing the path of the expansion in the pv -plane is given by $pv^{1.4} = \text{constant}$.

- 4.11 A stationary system consisting of 2 kg of the fluid of Problem 4.8 expands in an adiabatic process according to $pv^{1.2} = \text{constant}$. The initial conditions are 1 MPa and 200°C, and the final pressure is 0.1 MPa. Find W and ΔU for the process.

Why is the work transfer not equal to $\int pdV$?

$$\text{Ans. } W = 216.83, \Delta U = -216.83 \text{ kJ, } \int pdV = 434.4 \text{ kJ}$$

- 4.12 A mixture of gases expands at constant pressure from 1 MPa, 0.03 m³ to 0.06 m³ with 84 kJ positive heat transfer. There is no work other than that done on a piston. Find ΔE for the gaseous mixture.

$$\text{Ans. } 54 \text{ kJ}$$

The same mixture expands through the same state path while a stirring device does 21 kJ of work on the system. Find ΔE , W , and Q for the process.

$$\text{Ans. } 54 \text{ kJ, } -21 \text{ kJ, } 33 \text{ kJ}$$

- 4.13 A mass of 8 kg gas expands within a flexible container so that the $p-v$ relationship is of the form $pv^{1.2} = \text{const}$. The initial pressure is 1000 kPa and the initial volume is 1 m^3 . The final pressure is 5 kPa. If specific internal energy of the gas decreases by 40 kJ/kg, find the heat transfer in magnitude and direction.

Ans. + 2615 kJ

- 4.14 A gas of mass 1.5 kg undergoes a quasi-static expansion which follows a relationship $p = a + bV$, where a and b are constants. The initial and final pressures are 1000 kPa and 200 kPa respectively and the corresponding volumes are 0.20 m^3 and 1.20 m^3 . The specific internal energy of the gas is given by the relation

$$u = 1.5 pv - 85 \text{ kJ/kg}$$

where p is in kPa and v is in m^3/kg . Calculate the net heat transfer and the maximum internal energy of the gas attained during expansion.

Ans. 660 kJ, 503.3 kJ

- 4.15 The heat capacity at constant pressure of a certain system is a function of temperature only and may be expressed as

$$C_p = 2.093 + \frac{41.87}{t + 100} \text{ J/K}$$

where t is the temperature of the system in $^{\circ}\text{C}$. The system is heated while it is maintained at a pressure of 1 atmosphere until its volume increases from 2000 cm^3 to 2400 cm^3 and its temperature increases from 0°C to 100°C . (a) Find the magnitude of the heat interaction. (b) How much does the internal energy of the system increase?

Ans. (a) 238.32J (b) 197.79 J

- 4.16 An imaginary engine receives heat and does work on a slowly moving piston at such rates that the cycle of operation of 1 kg of working fluid can be represented as a circle 10 cm in diameter on a $p-v$ diagram on which 1 cm = 300 kPa and 1 cm = $0.1 \text{ m}^3/\text{kg}$. (a) How much work is done by each kg of working fluid for each cycle of operation? (b) The thermal efficiency of an engine is defined as the ratio of work done and heat input in a cycle. If the heat rejected by the engine in a cycle is 1000 kJ per kg of working fluid, what would be its thermal efficiency?

Ans. (a) 2356.19 kJ/kg, (b) 0.702

- 4.17 A gas undergoes a thermodynamic cycle consisting of three processes beginning at an initial state where $p_1 = 1 \text{ bar}$, $V_1 = 1.5 \text{ m}^3$ and $U_1 = 512 \text{ kJ}$. The processes are as follows:

- (i) Process 1-2: Compression with $pV = \text{constant}$ to $p_2 = 2 \text{ bar}$, $U_2 = 690 \text{ kJ}$
- (ii) Process 2-3: $W_{23} = 0$, $Q_{23} = -150 \text{ kJ}$, and
- (iii) Process 3-1: $W_{31} = +50 \text{ kJ}$. Neglecting KE and PE changes, determine the heat interactions Q_{12} and Q_{31} .

Ans. 74 kJ, 22 kJ

- 4.18 A gas undergoes a thermodynamic cycle consisting of the following processes:
- (i) Process 1-2: Constant pressure $p = 1.4 \text{ bar}$, $V_1 = 0.028 \text{ m}^3$, $W_{12} = 10.5 \text{ kJ}$,
 - (ii) Process 2-3: Compression with $pV = \text{constant}$, $U_3 = U_2$,
 - (iii) Process 3-1: Constant volume, $U_1 - U_3 = -26.4 \text{ kJ}$. There are no significant changes in KE and PE. (a) Sketch the cycle on a $p-V$ diagram. (b) Calculate the net work for the

cycle in kJ. (c) Calculate the heat transfer for process 1–2 (d) Show that

$$\sum_{\text{cycle}} Q = \sum_{\text{cycle}} W.$$

cycle cycle

Ans. (b) – 8.28 kJ, (c) 36.9 kJ

- 4.19 A certain gas of mass 4 kg is contained within a piston cylinder assembly. The gas undergoes a process for which $pV^{1.5} = \text{constant}$. The initial state is given by 3 bar, 0.1 m^3 . The change in internal energy of the gas in the process is $u_2 - u_1 = -4.6 \text{ kJ/kg}$. Find the net heat transfer for the process when the final volume is 0.2 m^3 . Neglect the changes in KE and PE.

Ans. – 0.8 kJ

- 4.20 An electric generator coupled to a windmill produces an average electrical power output of 5 kW. The power is used to charge a storage battery. Heat transfer from the battery to the surroundings occurs at a constant rate of 0.6 kW. Determine the total amount of energy stored in the battery in 8h of operation.

Ans. $1.27 \times 10^5 \text{ kJ}$

- 4.21 A gas in a piston-cylinder assembly undergoes two processes in series. From state 1 to state 2 there is energy transfer by heat to the gas of 500 kJ, and the gas does work on the piston amounting 800 kJ. The second process, from state 2 to state 3, is a constant pressure compression at 400 kPa, during which there is a heat transfer from the gas amounting 450 kJ. The following data are also known: $U_1 = 2000 \text{ kJ}$ and $U_3 = 3500 \text{ kJ}$. Neglecting changes in KE and PE, calculate the change in volume of the gas during process 2–3.

Ans. – 5.625 m^3

- 4.22 Air is contained in a rigid well-insulated tank with a volume of 0.2 m^3 . The tank is fitted with a paddle wheel which transfers energy to the air at a constant rate of 4 W for 20 min. The initial density of the air is 1.2 kg/m^3 . If no changes in KE or PE occur, determine (a) the specific volume at the final state, (b) the change in specific internal energy of the air.

Ans. (a) $0.833 \text{ m}^3/\text{kg}$, (b) 20 kJ/kg

5

First Law Applied to Flow Processes

5.1 Control Volume

For any system and in any process, the first law can be written as

$$Q = \Delta E + W$$

where E represents all forms of energy stored in the system.

For a pure substance

$$E = E_K + E_p + U$$

where E_K is the K.E., E_p the P.E., and U the residual energy stored in the molecular structure of the substance.

$$Q = \Delta E_K + \Delta E_p + \Delta U + W \quad (5.1)$$

When there is mass transfer across the system boundary, the system is called an open system. Most of the engineering devices are open systems involving the flow of fluids through them.

Equation (5.1) refers to a system having a particular mass of substance, and is free to move from place to place.

Consider a steam turbine (Fig. 5.1) in which steam enters at a high pressure, does work upon the turbine rotor, and then leaves the turbine at low pressure through the exhaust pipe.

If a certain mass of steam is considered as the thermodynamic system, then the energy equation becomes

$$Q = \Delta E_K + \Delta E_p + \Delta U + W$$

and in order to analyze the expansion process in turbine the moving system is to be followed as it travels through the turbine, taking into account the work and heat interactions all the way through. This method of analysis is similar to that of Lagrange in fluid mechanics.

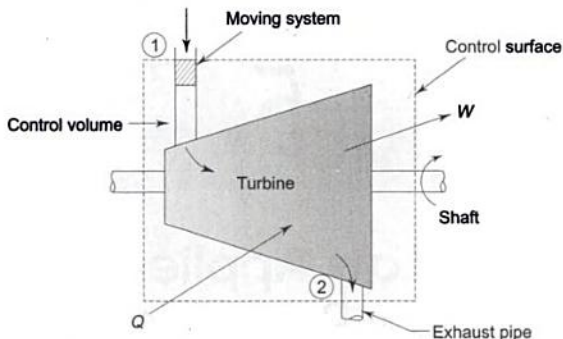

Fig. 5.1 Flow process involving work and heat interactions

Although the system approach is quite valid, there is another approach which is found to be highly convenient. Instead of concentrating attention upon a certain quantity of fluid, which constitutes a moving system in flow process, attention is focussed upon a certain fixed region in space called a *control volume* through which the moving substance flows. This is similar to the analysis of Euler in fluid mechanics.

To distinguish the two concepts, it may be noted that while the system (closed) boundary usually changes shape, position and orientation relative to the observer, the control volume boundary remains fixed and unaltered. Again, while matter usually crosses the control volume boundary, no such flow occurs across the system boundary.

The broken line in Fig. 5.1 represents the surface of the control volume which is known as the *control surface*. This is the same as the system boundary of the open system. The method of analysis is to inspect the control surface and account for all energy quantities transferred through this surface. Since there is mass transfer across the control surface, a mass balance also has to be made. Sections 1 and 2 allow mass transfer to take place, and Q and W are the heat and work interactions respectively.

5.2 Steady Flow Process

As a fluid flows through a certain control volume, its thermodynamic properties may vary along the space coordinates as well as with time. If the rates of flow of mass and energy through the control surface change with time, the mass and energy within the control volume also would change with time.

'Steady flow' means that the rates of flow of mass and energy across the control surface are constant.

In most engineering devices, there is a constant rate of flow of mass and energy through the control surface, and the control volume in course of time attains a steady state. *At the steady state of a system, any thermodynamic property will*

have a fixed value at a particular location, and will not alter with time. Thermodynamic properties may vary along space coordinates, but do not vary with time. 'Steady state' means that the state is steady or invariant with time.

5.3 Mass Balance and Energy Balance in a Simple Steady Flow Process

In Fig. 5.2, a steady flow system has been shown in which one stream of fluid enters and one stream leaves the control volume. There is no accumulation of mass or energy within the control volume, and the properties at any location within the control volume are steady with time. Sections 1.1 and 2.2 indicate, respectively, the entrance and exit of the fluid across the control surface. The following quantities are defined with reference to Fig. 5.2.

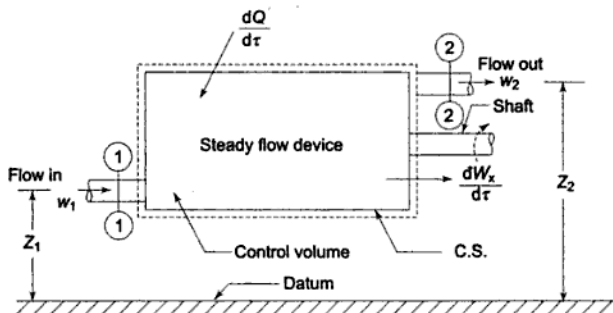

Fig. 5.2 Steady flow Process

- A_1, A_2 —cross-section of stream, m^2
 w_1, w_2 —mass flow rate, kg/s
 p_1, p_2 —pressure, absolute, N/m^2
 v_1, v_2 —specific volume, m^3/kg
 u_1, u_2 —specific internal energy, J/kg
 V_1, V_2 —velocity, m/s
 Z_1, Z_2 —elevation above an arbitrary datum, m

$\frac{dQ}{d\tau}$ —net rate of heat transfer through the control surface, J/s

$\frac{dW_x}{d\tau}$ —net rate of work transfer through the control surface, J/s

exclusive of work done at sections 1 and 2 in transferring the fluid through the control surface.

τ —time, s .

Subscripts 1 and 2 refer to the inlet and exit sections.

5.3.1 Mass Balance

By the conservation of mass, if there is no accumulation of mass within the control volume, the mass flow rate entering must equal the mass flow rate leaving, or

$$w_1 = w_2$$

or

$$\frac{A_1 V_1}{v_1} = \frac{A_2 V_2}{v_2} \quad (5.2)$$

This equation is known as the *equation of continuity*.

5.3.2 Energy Balance

In a flow process, the work transfer may be of two types: the *external work* and the *flow work*. The external work refers to all the work transfer across the control surface other than that due to normal fluid forces. In engineering thermodynamics the only kinds of external work of importance are *shear* (shaft or stirring) *work* and *electrical work*. In Fig. 5.2 the only external work occurs in the form of shaft work, W_x . The flow work, as discussed in Sec. 3.4, is the displacement work done by the fluid of mass dm_1 at the inlet section 1 and that of mass dm_2 at the exit section 2, which are $(-p_1 v_1 dm_1)$ and $(+p_2 v_2 dm_2)$ respectively. Therefore, the total work transfer is given by

$$W = W_x - p_1 v_1 dm_1 + p_2 v_2 dm_2 \quad (5.3)$$

In the rate form,

$$\frac{dW}{d\tau} = \frac{dW_x}{d\tau} - p_1 v_1 \frac{dm_1}{d\tau} + p_2 v_2 \frac{dm_2}{d\tau}$$

or

$$\frac{dW}{d\tau} = \frac{dW_x}{d\tau} - w_1 p_1 v_1 + w_2 p_2 v_2 \quad (5.4)$$

Since there is no accumulation of energy, by the conservation of energy, the total rate of flow of all energy streams entering the control volume must equal the total rate of flow of all energy streams leaving the control volume. This may be expressed in the following equation.

$$w_1 e_1 + \frac{dQ}{d\tau} = w_2 e_2 + \frac{dW}{d\tau}$$

Substituting for $\frac{dW}{d\tau}$ from Eq. (5.4)

$$w_1 e_1 + \frac{dQ}{d\tau} = w_2 e_2 + \frac{dW_x}{d\tau} - w_1 p_1 v_1 + w_2 p_2 v_2$$

$$w_1 e_1 + w_1 p_1 v_1 + \frac{dQ}{d\tau} = w_2 e_2 + w_2 p_2 v_2 + \frac{dW_x}{d\tau} \quad (5.5)$$

where e_1 and e_2 refer to the energy carried into or out of the control volume with unit mass of fluid.

The specific energy e is given by

$$\begin{aligned} e &= e_k + e_p + u \\ &= \frac{V^2}{2} + Zg + u \end{aligned} \quad (5.6)$$

Substituting the expression for e in Eq. (5.5)

$$\begin{aligned} w_1 \left(\frac{V_1^2}{2} + Z_1g + u_1 \right) + w_1 p_1 v_1 + \frac{dQ}{d\tau} \\ = w_2 \left(\frac{V_2^2}{2} + Z_2g + u_2 \right) + w_2 p_2 v_2 + \frac{dW_x}{d\tau} \end{aligned}$$

$$\begin{aligned} \text{or} \quad w_1 \left(h_1 + \frac{V_1^2}{2} + Z_1g \right) + \frac{dQ}{d\tau} \\ = w_2 \left(h_2 + \frac{V_2^2}{2} + Z_2g \right) + \frac{dW_x}{d\tau} \end{aligned} \quad (5.7)$$

where $h = u + pv$.

And, since $w_1 = w_2$, let $w = w_1 = w_2 = \frac{dm}{d\tau}$

Dividing Eq. (5.7) by $\frac{dm}{d\tau}$

$$\begin{aligned} h_1 + \frac{V_1^2}{2} + Z_1g + \frac{dQ}{dm} \\ = h_2 + \frac{V_2^2}{2} + Z_2g + \frac{dW_x}{dm} \end{aligned} \quad (5.8)$$

Equations (5.7) and (5.8) are known as *steady flow energy equations* (S.F.E.E.), for a single stream of fluid entering and a single stream of fluid leaving the control volume. All the terms in Eq. (5.8) represent energy flow per unit mass of fluid (J/kg) whereas all the terms in Eq. (5.7) represent energy flow per unit time (J/kg). The basis of energy flow per unit mass is usually more convenient when only a single stream of fluid enters and leaves a control volume. When more than one fluid stream is involved the basis of energy flow per unit time is more convenient.

Equation (5.8) can be written in the following form,

$$Q - W_x = (h_2 - h_1) + \frac{\bar{V}_2^2 - \bar{V}_1^2}{2} + g(Z_2 - Z_1) \quad (5.9)$$

where Q and W_x refer to energy transfer per unit mass. In the differential form, the SFEE becomes

$$dQ - dW_x = dh + \bar{V}d\bar{V} + gdZ \quad (5.10)$$

When more than one stream of fluid enters or leaves the control volume (Fig. 5.3), the mass balance and energy balance for steady flow are given below.

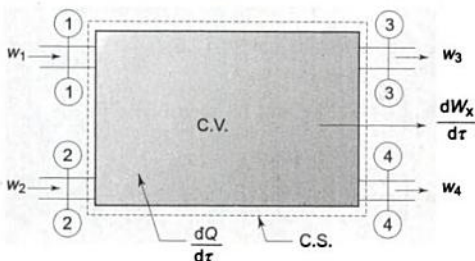

Fig. 5.3 Steady flow process involving two fluid streams at the inlet and exit of the control volume

Mass balance

$$w_1 + w_2 = w_3 + w_4 \quad (5.11)$$

$$\frac{A_1 V_1}{v_1} + \frac{A_2 V_2}{v_2} = \frac{A_3 V_3}{v_3} + \frac{A_4 V_4}{v_4} \quad (5.12)$$

Energy balance

$$\begin{aligned} w_1 \left(h_1 + \frac{V_1^2}{2} + Z_1 g \right) + w_2 \left(h_2 + \frac{V_2^2}{2} + Z_2 g \right) + \frac{dQ}{d\tau} \\ = w_3 \left(h_3 + \frac{V_3^2}{2} + Z_3 g \right) + w_4 \left(h_4 + \frac{V_4^2}{2} + Z_4 g \right) + \frac{dW_x}{d\tau} \end{aligned} \quad (5.13)$$

The steady flow energy equation applies to a wide variety of processes like pipe line flows, heat transfer processes, mechanical power generation in engines and turbines, combustion processes, and flows through nozzles and diffusers. In certain problems, some of the terms in steady flow energy equation may be negligible or zero. But it is best to write the full equation first, and then eliminate the terms which are unnecessary.

5.4 Some Examples of Steady Flow Processes

The following examples illustrate the applications of the steady flow energy equation in some of the engineering systems.

5.4.1 Nozzle and Diffusor

A nozzle is a device which increases the velocity or K.E. of a fluid at the expense of its pressure drop, whereas a diffusor increases the pressure of a fluid at the

expense of its K.E. Figure 5.4 shows a nozzle which is insulated. The steady flow energy equation of the control surface gives

$$h_1 + \frac{V_1^2}{2} + Z_1 g + \frac{dQ}{dm} = h_2 + \frac{V_2^2}{2} + Z_2 g + \frac{dW_x}{dm}$$

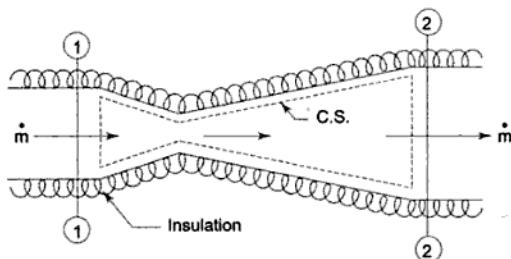

Fig. 5.4 Steady flow process involving one fluid stream at the inlet and at exit of the control volume

Here $\frac{dQ}{dm} = 0$, $\frac{dW_x}{dm} = 0$, and the change in potential energy is zero.

The equation reduces to

$$h_1 + \frac{V_1^2}{2} = h_2 + \frac{V_2^2}{2} \quad (5.14)$$

The continuity equation gives

$$w = \frac{A_1 V_1}{v_1} = \frac{A_2 V_2}{v_2} \quad (5.15)$$

When the inlet velocity or the 'velocity of approach' V_1 is small compared to the exit velocity V_2 , Eq. (5.14) becomes

$$h_1 = h_2 + \frac{V_2^2}{2}$$

or

$$V_2 = \sqrt{2(h_1 - h_2)} \text{ m/s}$$

where $(h_1 - h_2)$ is in J/kg.

Equations (5.14) and (5.15) hold good for a diffusor as well.

5.4.2 Throttling Device

When a fluid flows through a constricted passage, like a partially opened valve, an orifice, or a porous plug, there is an appreciable drop in pressure, and the flow is said to be throttled. Figure 5.5 shows the process of throttling by a partially opened valve on a fluid flowing in an insulated pipe. In the steady-flow energy Eq. (5.8),

$$\frac{dQ}{dm} = 0, \frac{dW_x}{dm} = 0$$

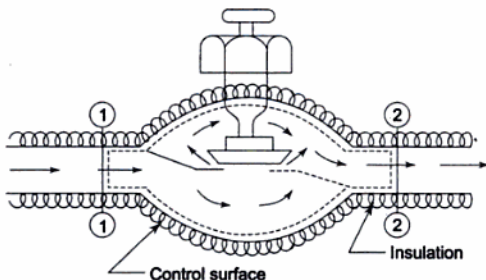

Fig. 5.5 Flow through a valve

and the changes in P.E. are very small and ignored. Thus the S.F.E.E. reduces to

$$h_1 + \frac{V_1^2}{2} = h_2 + \frac{V_2^2}{2}$$

Often the pipe velocities in throttling are so low that the K.E. terms are also negligible. So

$$h_1 = h_2 \quad (5.16)$$

or the enthalpy of the fluid before throttling is equal to the enthalpy of the fluid after throttling.

5.4.3 Turbine and Compressor

Turbines and engines give positive power output, whereas compressors and pumps require power input.

For a turbine (Fig. 5.6) which is well insulated, the flow velocities are often small, and the K.E. terms can be neglected. The S.F.E.E. then becomes

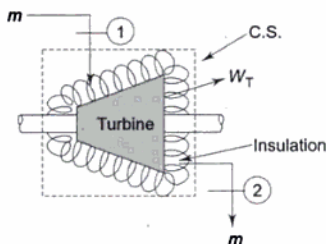

Fig. 5.6 Flow through a turbine

$$h_1 = h_2 + \frac{dW_x}{dm}$$

or

$$\frac{W_x}{m} = (h_1 - h_2)$$

It is seen that work is done by the fluid at the expense of its enthalpy.

Similarly, for an adiabatic pump or compressor, work is done upon the fluid and W is negative. So the S.F.E.E. becomes

$$h_1 = h_2 - \frac{W_x}{m}$$

or

$$\frac{W_x}{m} = h_2 - h_1$$

The enthalpy of the fluid increases by the amount of work input.

5.4.4 Heat Exchanger

A heat exchanger is a device in which heat is transferred from one fluid to another. Figure 5.7 shows a steam condenser, where steam condensers outside the tubes and cooling water flows through the tubes. The S.F.E.E. for the C.S. gives

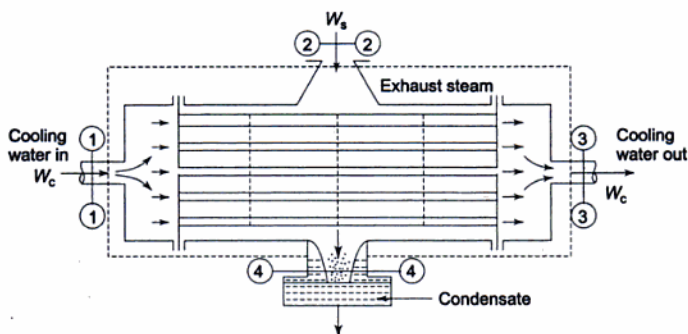

Fig. 5.7 Steam condenser

$$w_c h_1 + w_s h_2 = w_c h_3 + w_s h_4$$

or

$$w_s (h_2 - h_4) = w_c (h_3 - h_1)$$

Here the K.E. and P.E. terms are considered small, there is no external work done, and energy exchange in the form of heat is confined only between the two fluids, i.e., there is no external heat interaction or heat loss.

Figure 5.8 shows a steam desuperheater where the temperature of the superheated steam is reduced by spraying water. If w_1 , w_2 , and w_3 are the mass

flow rates of the injected water, of the steam entering, and of the steam leaving, respectively, and h_1 , h_2 , and h_3 are the corresponding enthalpies, and if K.E. and P.E. terms are neglected as before, the S.F.E.E. becomes

$$w_1 h_1 + w_2 h_2 = w_3 h_3$$

and the mass balance gives

$$w_1 + w_2 = w_3$$

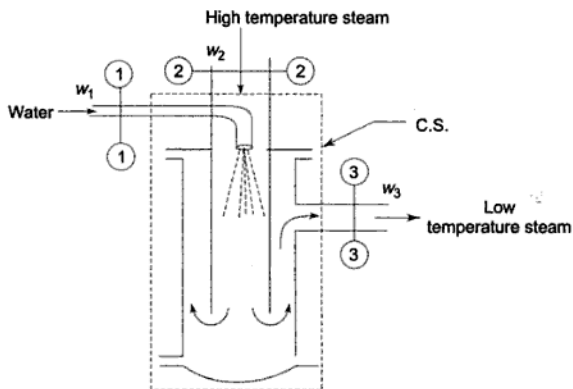

Fig. 5.8 Steam desuperheater

5.5 Comparison of S.F.E.E. with Euler and Bernoulli Equations

The steady flow energy Eq. (5.8) can be written as

$$\frac{dQ}{dm} = (h_2 - h_1) + \frac{\bar{V}_2^2 - \bar{V}_1^2}{2} + (Z_2 - Z_1)g + \frac{dW_x}{dm}$$

In the differential form the S.F.E.E. becomes

$$dQ = dh + \bar{V} d\bar{V} + gdZ + dW_x \quad (5.17)$$

where dQ and dW_x refer to unit mass of the substance. Since $h = u + pv$ and $dQ = du + pdv$ (for a quasi-static path involving only pdv -work), Eq. (5.17) can be written as

$$du + pdv = du + pdv + Vdp + VdV + gdZ + dW_x$$

For an inviscid frictionless fluid flowing through a pipe

$$Vdp + VdV + gdZ = 0 \quad (5.18)$$

This is the *Euler equation*. If we integrate between two sections 1 and 2 of the pipe

$$\int_1^2 v dp + \int_1^2 V dV + \int_1^2 g dZ = 0$$

For an incompressible fluid, $v = \text{constant}$

$$\therefore v(p_2 - p_1) + \frac{V_2^2}{2} - \frac{V_1^2}{2} + g(Z_2 - Z_1) = 0 \quad (5.19)$$

Since the specific volume v is the reciprocal of the density ρ , we have

$$\frac{p_1}{\rho} + \frac{V_1^2}{2} + Z_1 g = \frac{p_2}{\rho} + \frac{V_2^2}{2} + Z_2 g \quad (5.20)$$

$$\text{or} \quad \frac{p}{\rho} + \frac{V^2}{2} + Zg = \text{constant} \quad (5.21)$$

This is known as the *Bernoulli equation*, which is valid for an inviscid incompressible fluid. It can also be expressed in the following form

$$\Delta \left(pv + \frac{V^2}{2} + gZ \right) = 0 \quad (5.22)$$

where v is constant and $\Delta(\dots)$ means 'increase in...'

The S.F.E.E. as given by Eq. (5.18) or Eq. (5.17) can be written with $(u + pv)$ substituted for h , as follows:

$$Q - W_x = \Delta \left(u + pv + \frac{V^2}{2} + gZ \right) \quad (5.23)$$

A comparison of Eqs (5.22) and (5.23) shows that they have several terms in common. However, while the Bernoulli equation is restricted to frictionless incompressible fluids, the S.F.E.E. is not, and is valid for viscous compressible fluids as well. The Bernoulli equation is, therefore, a special limiting case of the more general steady flow energy equation.

5.6 Variable Flow Processes

Many flow processes, such as filling up and evacuating gas cylinders, are not steady. Such processes can be analyzed by the control volume technique. Consider a device through which a fluid is flowing under non-steady state conditions (Fig. 5.9). The rate at which the mass of fluid within the control volume is accumulated as equal to the net rate of mass flow across the control surface, as given below

$$\frac{dm_V}{d\tau} = w_1 - w_2 = \frac{dm_1}{d\tau} - \frac{dm_2}{d\tau} \quad (5.24)$$

where m_V is the mass of fluid within the control volume at any instant.

Over any finite period of time

$$\Delta m_V = \Delta m_1 - \Delta m_2 \quad (5.25)$$

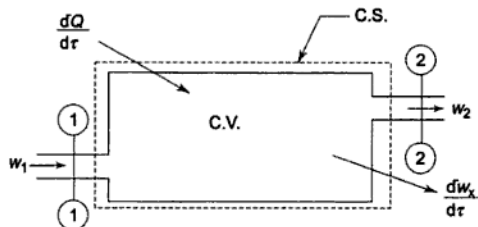

Fig. 5.9 Variable flow process

The rate of accumulation of energy within the control volume is equal to the net rate of energy flow across the control surface. If E_V is the energy of fluid within the control volume at any instant.

Rate of energy increase = Rate of energy inflow - Rate of energy outflow

$$\begin{aligned} \frac{dE_V}{d\tau} &= w_1 \left(h_1 + \frac{V_1^2}{2} + Z_1 g \right) + \frac{dQ}{d\tau} \\ &\quad - w_2 \left(h_2 + \frac{V_2^2}{2} + Z_2 g \right) - \frac{dW_x}{d\tau} \end{aligned} \quad (5.26)$$

Now

$$E_V = \left(U + \frac{mV^2}{2} + mgZ \right)_V$$

where m is the mass of fluid in the control volume at any instant.

$$\begin{aligned} \therefore \frac{dE_V}{d\tau} &= \frac{d}{d\tau} \left(U + \frac{mV^2}{2} + mgZ \right)_V \\ &= \left(h_1 + \frac{V_1^2}{2} + Z_1 g \right) \frac{dm_1}{d\tau} + \frac{dQ}{d\tau} \\ &\quad - \left(h_2 + \frac{V_2^2}{2} + Z_2 g \right) \frac{dm_2}{d\tau} - \frac{dW_x}{d\tau} \end{aligned} \quad (5.27)$$

Figure 5.10 shows all these energy flux quantities. For any finite time interval, equation (5.27) becomes

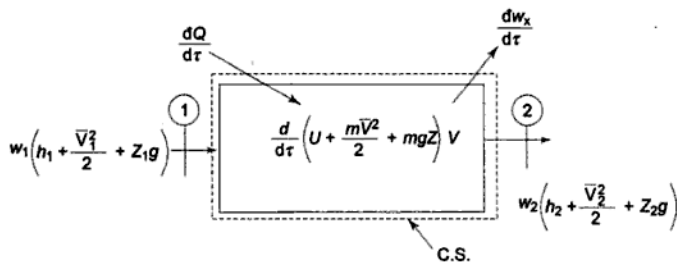

Fig. 5.10 Energy fluxes in an unsteady system

$$\begin{aligned} \Delta E_V = Q - W_x + \int \left(h_1 + \frac{V_1^2}{2} + Z_1g \right) dm_1 \\ - \int \left(h_2 + \frac{V_2^2}{2} + Z_2g \right) dm_2 \end{aligned} \quad (5.28)$$

Equation (5.26) is the *general energy equation*. For steady flow,

$$\frac{dE_V}{d\tau} = 0,$$

and the equation reduces to Eq. (5.7). For a closed system $w_1 = 0$, $w_2 = 0$, then from Eq. (5.26),

$$\frac{dE_V}{d\tau} = \frac{dQ}{d\tau} - \frac{dW_x}{d\tau}$$

or $dE_V = dQ - dW_x$ or, $dQ = dE + dW_x$
as obtained earlier.

5.7 Example of a Variable Flow Problem

Variable flow processes may be analyzed either by the system technique or the control volume technique, as illustrated below.

Consider a process in which a gas bottle is filled from a pipeline (Fig. 5.11). In the beginning the bottle contains gas of mass m_1 at state p_1, t_1, v_1, h_1 and u_1 . The valve is opened and gas flows into the bottle till the mass of gas in the bottle is m_2 at state p_2, t_2, v_2, h_2 and u_2 . The supply to the pipeline is very large so that the state of gas in the pipeline is constant at p_p, t_p, v_p, h_p, u_p and V_p .

System Technique Assume an envelope (which is extensible) of gas in the pipeline and the tube which would eventually enter the bottle, as shown in Fig. 5.11.

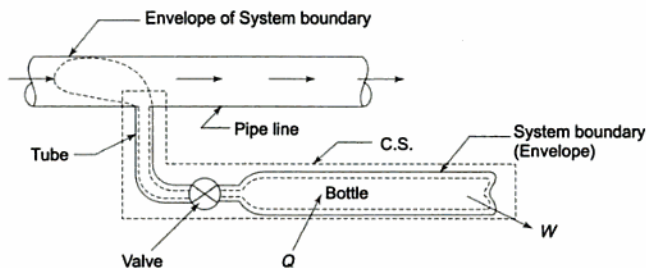

Fig. 5.11 Bottle-filling process

Energy of the gas before filling

$$E_1 = m_1 u_1 + (m_2 - m_1) \left(\frac{V_p^2}{2} + u_p \right)$$

where $(m_2 - m_1)$ is the mass of gas in the pipeline and tube which would enter the bottle.

Energy of the gas after filling

$$E_2 = m_2 u_2$$

$$\Delta E = E_2 - E_1 = m_2 u_2 - \left[m_1 u_1 + (m_2 - m_1) \left(\frac{V_p^2}{2} + u_p \right) \right] \quad (5.29)$$

The P.E. terms are neglected: The gas in the bottle is not in motion, and so the K.E. terms have been omitted.

Now, there is a change in the volume of gas because of the collapse of the envelope to zero volume. Then the work done

$$\begin{aligned} W &= p_p (V_2 - V_1) = p_p [0 - (m_2 - m_1) v_p] \\ &= -(m_2 - m_1) p_p v_p \end{aligned}$$

\therefore Using the first law for the process

$$\begin{aligned} Q &= \Delta E + W \\ &= m_2 u_2 - m_1 u_1 - (m_2 - m_1) \left(\frac{V_p^2}{2} + u_p \right) - (m_2 - m_1) p_p v_p \\ &= m_2 u_2 - m_1 u_1 - (m_2 - m_1) \left(\frac{V_p^2}{2} + h_p \right) \end{aligned} \quad (5.30)$$

which gives the energy balance for the process.

Control Volume Technique Assume a control volume bounded by a control surface, as shown in Fig. 5.11. Applying the energy Eq. (5.27) to this case, the following energy balance may be written on a time rate basis

$$\frac{dE_v}{d\tau} = \frac{dQ}{d\tau} + \left(h_p + \frac{V_p^2}{2} \right) \frac{dm}{d\tau}$$

Since h_p and V_p are constant, the equation is integrated to give for the total process

$$\Delta E_v = Q + \left(h_p + \frac{V_p^2}{2} \right) (m_2 - m_1)$$

Now

$$\Delta E_v = U_2 - U_1 = m_2 u_2 - m_1 u_1$$

\therefore

$$Q = m_2 u_2 - m_1 u_1 - \left(h_p + \frac{V_p^2}{2} \right) (m_2 - m_1)$$

This equation is the same as Eq. (5.30).

If $m_1 = 0$, i.e., the bottle is initially evacuated,

$$Q = m_2 u_2 - m_2 \left(h_p + \frac{V_p^2}{2} \right)$$

Again, if $Q = 0$ and $h_p \gg \frac{V_p^2}{2}$,

$$0 = m_2 u_2 - m_2 h_p$$

or,

$$u_2 = h_p = u_p + p_p v_p$$

Thus, flow work ($p_p v_p$) is converted to increase in molecular internal energy ($u_2 - u_p$).

If the gas is assumed ideal,

$$c_v T_2 = c_p T_p$$

or,

$$T_2 = \gamma T_p$$

If $T_p = 27 + 273 = 300$ K, then for air

$$T_2 = 1.4 \times 300 = 420$$
 K

or,

$$t_2 = 147^\circ\text{C}$$

Therefore, in adiabatically filling a bottle with air at 27°C , the gas temperature rises to 147°C due to the flow work being converted to internal energy increase.

5.8 Discharging and Charging a Tank

Let us consider a tank discharging a fluid into a supply line (Fig. 5.12). Since $dW_x = 0$ and $dm_{in} = 0$, applying first law to the control volume,

$$dU_v = dQ + \left(h + \frac{V^2}{2} + gz \right)_{out} dm_{out} \quad (5.31)$$

Assuming K.E. and P.E. of the fluid to be small and $dQ = 0$

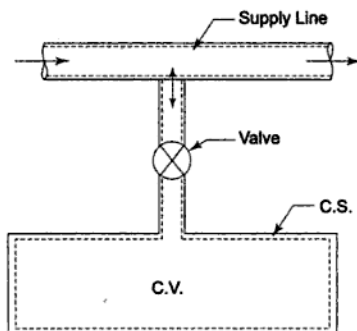

Fig. 5.12 Charging and discharging a tank

$$d(mu) = hdm$$

$$mdu + udm = udm + pv dm$$

$$\frac{dm}{m} = \frac{du}{pv} \quad (5.32)$$

Again

$$V = vm = \text{const.}$$

$$vdm + mdv = 0$$

or

$$\frac{dm}{m} = -\frac{dv}{v} \quad (5.33)$$

From Eqs (5.32) and (5.33),

$$\frac{du}{pv} = -\frac{dv}{v}$$

$$d(u + pv) = 0$$

or

$$\delta Q = 0$$

which shows that the process is adiabatic and quasi-static.

For charging the tank

$$\int (hdm)_{in} = \Delta U_V = m_2 u_2 - m_1 u_1 \quad (5.34)$$

$$m_p h_p = m_2 u_2 - m_1 u_1$$

where the subscript p refers to the constant state of the fluid in the pipeline. If the tank is initially empty, $m_1 = 0$.

$$m_p h_p = m_2 u_2$$

Since

$$m_p = m_2$$

$$h_p = u_2$$

Enthalpy is converted to internal energy.

If the fluid is an ideal gas, the temperature of the gas in the tank after it is charged is given by

$$\begin{aligned} c_p T_p &= c_v T_2 \\ \text{or} \quad T_2 &= \gamma T_p \end{aligned} \quad (5.35)$$

SOLVED EXAMPLES

Example 5.1 Air flows steadily at the rate of 0.5 kg/s through an air compressor, entering at 7 m/s velocity, 100 kPa pressure, and $0.95 \text{ m}^3/\text{kg}$ volume, and leaving at 5 m/s, 700 kPa, and $0.19 \text{ m}^3/\text{kg}$. The internal energy of the air leaving is 90 kJ/kg greater than that of the air entering. Cooling water in the compressor jackets absorbs heat from the air at the rate of 58 kW. (a) Compute the rate of shaft work input to the air in kW. (b) Find the ratio of the inlet pipe diameter to outlet pipe diameter.

Solution Figure Ex. 5.1 shows the details of the problem.

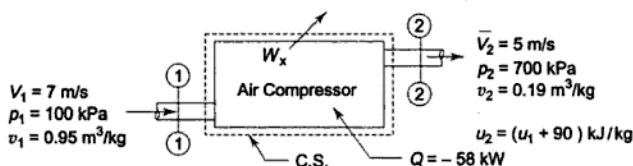

Fig. Ex. 5.1

(a) Writing the steady flow energy equation, we have

$$\begin{aligned} w \left(u_1 + p_1 v_1 + \frac{V_1^2}{2} + Z_1 g \right) + \frac{dQ}{d\tau} \\ = w \left(u_2 + p_2 v_2 + \frac{V_2^2}{2} + Z_2 g \right) + \frac{dW_x}{d\tau} \\ \therefore \frac{dW_x}{d\tau} = -w \left[(u_2 - u_1) + (p_2 v_2 - p_1 v_1) + \frac{V_2^2 - V_1^2}{2} + (Z_2 - Z_1)g \right] + \frac{dQ}{d\tau} \\ \therefore \frac{dW_x}{d\tau} = -0.5 \frac{\text{kg}}{\text{s}} \left[90 \frac{\text{kJ}}{\text{kg}} + (7 \times 0.19 - 1 \times 0.95) 100 \frac{\text{kJ}}{\text{kg}} \right. \\ \left. + \frac{(5^2 - 7^2) \times 10^{-3}}{2} \frac{\text{kJ}}{\text{kg}} + 0 \right] - 58 \text{ kW} \\ = -0.5 [90 + 38 - 0.012] \text{ kJ/s} - 58 \text{ kW} \\ = -122 \text{ kW} \end{aligned}$$

Ans. (a)

Rate of work input is 122 kW.

(b) From mass balance, we have

$$w = \frac{A_1 V_1}{v_1} = \frac{A_2 V_2}{v_2}$$

$$\therefore \frac{A_1}{A_2} = \frac{v_1}{v_2} \cdot \frac{V_2}{V_1} = \frac{0.95}{0.19} \times \frac{5}{7} = 3.57$$

$$\therefore \frac{d_1}{d_2} = \sqrt{3.57} = 1.89 \quad \text{Ans. (b)}$$

Example 5.2 In a steady flow apparatus, 135 kJ of work is done by each kg of fluid. The specific volume of the fluid, pressure, and velocity at the inlet are $0.37 \text{ m}^3/\text{kg}$, 600 kPa, and 16 m/s. The inlet is 32 m above the floor, and the discharge pipe is at floor level. The discharge conditions are $0.62 \text{ m}^3/\text{kg}$, 100 kPa, and 270 m/s. The total heat loss between the inlet and discharge is 9 kJ/kg of fluid. In flowing through this apparatus, does the specific internal energy increase or decrease, and by how much?

Solution Writing the steady flow energy equation for the control volume, as shown in Fig. Ex. 5.2.

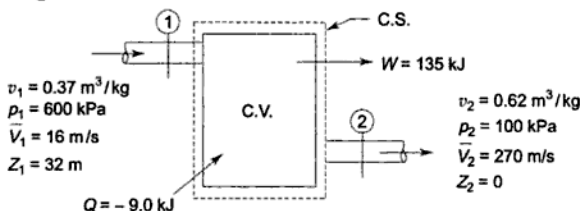

Fig. Ex. 5.2

$$u_1 + p_1 v_1 + \frac{V_1^2}{2} + Z_1 g + \frac{dQ}{dm} = u_2 + p_2 v_2 + \frac{V_2^2}{2} + Z_2 g + \frac{dW_x}{dm}$$

$$\therefore u_1 - u_2 = (p_2 v_2 - p_1 v_1) + \frac{V_2^2 - V_1^2}{2} + (Z_2 - Z_1)g + \frac{dW_x}{dm} - \frac{dQ}{dm}$$

$$\begin{aligned} &= (1 \times 0.62 - 6 \times 0.37) \times 10^2 + \frac{(270^2 - 16^2) \times 10^{-3}}{2} \\ &\quad + (-32 \times 9.81 \times 10^{-3}) + 135 - (-9.0) \\ &= -160 + 36.45 - 0.314 + 135 + 9 \\ &= 20.136 \text{ kJ/kg} \end{aligned}$$

Specific internal energy decreases by 20.136 kJ.

Example 5.3 In a steam power station, steam flows steadily through a 0.2 m diameter pipeline from the boiler to the turbine. At the boiler end, the steam conditions are found to be: $p = 4 \text{ MPa}$, $t = 400^\circ\text{C}$, $h = 3213.6 \text{ kJ/kg}$, and $v = 0.073 \text{ m}^3/\text{kg}$. At the turbine end, the conditions are found to be: $p = 3.5 \text{ MPa}$, $t = 392^\circ\text{C}$, $h = 3202.6 \text{ kJ/kg}$, and $v = 0.084 \text{ m}^3/\text{kg}$. There is a heat loss of 8.5 kJ/kg from the pipeline. Calculate the steam flow rate.

Solution Writing the steady flow energy equation for the control volume as shown in Fig. Ex. 5.3

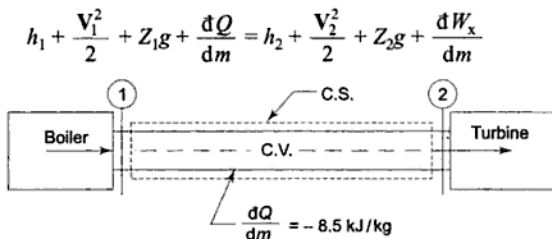

Fig. Ex. 5.3

Here, there is no change in datum, so change in potential energy will be zero.

Now
$$\frac{A_1 V_1}{v_1} = \frac{A_2 V_2}{v_2}$$

$$\therefore V_2 = \frac{A_1 V_1}{v_1} \cdot \frac{v_2}{A_2} = \frac{v_2}{v_1} \cdot V_1 = \frac{0.084}{0.073} V_1 = 1.15 V_1$$

and
$$\frac{dW_x}{dm} = 0$$

$$h_1 + \frac{V_1^2}{2} + \frac{dQ}{dm} = h_2 + \frac{V_2^2}{2}$$

$$\therefore \frac{(V_2^2 - V_1^2) \times 10^{-3}}{2} = h_1 - h_2 + \frac{dQ}{dm}$$

$$= 3213.6 - 3202.6 + (-8.5)$$

$$= 2.5 \text{ kJ/kg}$$

$$V_1^2 (1.15^2 - 1^2) = 5 \times 10^3$$

$$V_1^2 = 15,650 \text{ m}^2/\text{s}^2$$

$$\therefore V_1 = 125.1 \text{ m/s}$$

$$\therefore \text{Mass flow rate } w = \frac{A_1 V_1}{v_1} = \frac{\frac{\pi}{4} \times (0.2)^2 \text{ m}^2 \times 125.1 \text{ m/s}}{0.073 \text{ m}^3/\text{kg}}$$

$$= 53.8 \text{ kg/s}$$

Ans.

Example 5.4 A certain water heater operates under steady flow conditions receiving 4.2 kg/s of water at 75°C temperature, enthalpy 313.93 kJ/kg. The water is heated by mixing with steam which is supplied to the heater at temperature 100.2°C and enthalpy 2676 kJ/kg. The mixture leaves the heater as liquid water at temperature 100°C and enthalpy 419 kJ/kg. How much steam must be supplied to the heater per hour?

Solution By mass balance across the control surface (Fig. Ex. 5.4)

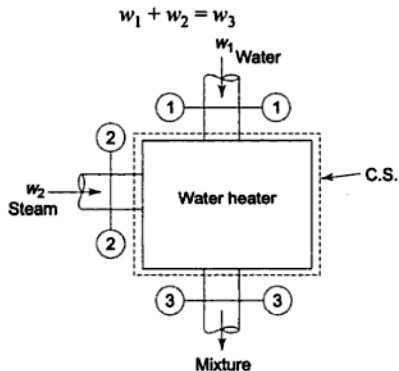

Fig. Ex. 5.4

By energy balance

$$w_1 \left(h_1 + \frac{V_1^2}{2} + Z_1 g \right) + \frac{dQ}{d\tau} + w_2 \left(h_2 + \frac{V_2^2}{2} + Z_2 g \right) \\ = w_3 \left(h_3 + \frac{V_3^2}{2} + Z_3 g \right) + \frac{dW_x}{d\tau}$$

By the nature of the process, there is no shaft work. Potential and kinetic energy terms are assumed to balance zero. The heater is assumed to be insulated. So the steady flow energy equation reduces to

$$w_1 h_1 + w_2 h_2 = w_3 h_3$$

$$4.2 \times 313.93 + w_2 \times 2676 = (4.2 + w_2) 419$$

$$\therefore w_2 = 0.196 \text{ kg/s} \\ = 705 \text{ kg/h}$$

Ans.

Example 5.5 Air at a temperature of 15°C passes through a heat exchanger at a velocity of 30 m/s where its temperature is raised to 800°C. It then enters a turbine with the same velocity of 30 m/s and expands until the temperature falls to 650°C. On leaving the turbine, the air is taken at a velocity of 60 m/s to a nozzle

where it expands until the temperature has fallen to 500°C. If the air flow rate is 2 kg/s, calculate (a) the rate of heat transfer to the air in the heat exchanger, (b) the power output from the turbine assuming no heat loss, and (c) the velocity at exit from the nozzle, assuming no heat loss. Take the enthalpy of air as $h = c_p t$, where c_p is the specific heat equal to 1.005 kJ/kg K and t the temperature.

Solution As shown in Fig. Ex. 5.5, writing the S.F.E.E. for the heat exchanger and eliminating the terms not relevant,

$$w \left(h_1 + \frac{V_1^2}{2} + Z_1 g \right) + Q_{1-2} = w \left(h_2 + \frac{V_2^2}{2} + Z_2 g \right) + W_{1-2}$$

$$\therefore wh_1 + Q_{1-2} = wh_2$$

$$\begin{aligned} \therefore Q_{1-2} &= w(h_2 - h_1) = wc_p(t_2 - t_1) \\ &= 2 \times 1.005(800 - 15) \\ &= 2.01 \times 785 \\ &= 1580 \text{ kJ/s} \end{aligned}$$

Ans. (a).

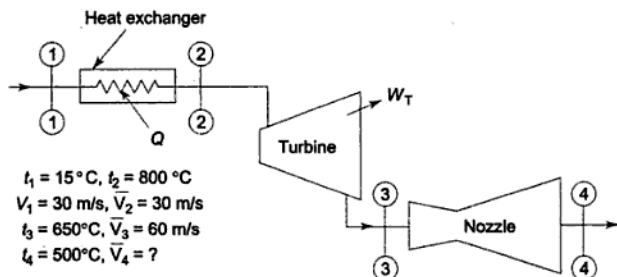

Fig. Ex. 5.5

Energy equation for the turbine gives

$$w \left(\frac{V_2^2}{2} + h_2 \right) = wh_3 + w \frac{V_3^2}{2} + W_T$$

$$\frac{V_2^2 - V_3^2}{2} + (h_2 - h_3) = W_T/w$$

$$\frac{(30^2 - 60^2) \times 10^{-3}}{2} + 1.005(800 - 650) = W_T/w$$

$$\therefore \frac{W_T}{w} = -1.35 + 150.75$$

$$= 149.4 \text{ kJ/kg}$$

$$\therefore W_T = 149.4 \times 2 \text{ kJ/s}$$

$$= 298.8 \text{ kW}$$

Ans. (b)

Writing the energy equation for the nozzle

$$\frac{V_3^2}{2} + h_3 = \frac{V_4^2}{2} + h_4$$

$$\frac{V_4^2 - V_3^2}{2} = c_p(t_3 - t_4)$$

$$V_4^2 - V_3^2 = 1.005 (650 - 500) \times 2 \times 10^3$$

$$= 301.50 \times 10^3 \text{ m}^2/\text{s}^2$$

$$V_4^2 = 30.15 \times 10^4 + 0.36 \times 10^4$$

$$= 30.51 \times 10^4 \text{ m}^2/\text{s}^2$$

∴ Velocity at exit from the nozzle

$$V_4 = 554 \text{ m/s}$$

Ans. (c)

Example 5.6 The air speed of a turbojet engine in flight is 270 m/s. Ambient air temperature is -15°C . Gas temperature at outlet of nozzle is 600°C . Corresponding enthalpy values for air and gas are respectively 260 and 912 kJ/kg. Fuel-air ratio is 0.0190. Chemical energy of the fuel is 44.5 MJ/kg. Owing to incomplete combustion 5% of the chemical energy is not released in the reaction. Heat loss from the engine is 21 kJ/kg of air. Calculate the velocity of the exhaust jet.

Solution Energy equation for the turbojet engine (Fig. Ex. 5.6) gives

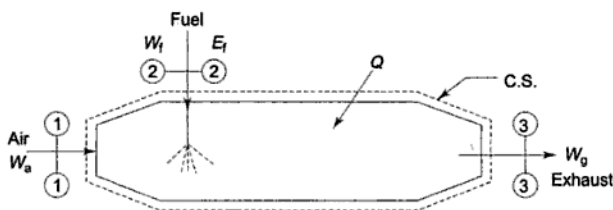

Fig. Ex. 5.6

$$w_a \left(h_a + \frac{V_a^2}{2} \right) + w_f E_f + Q = w_g \left(h_g + \frac{V_g^2}{2} + E_g \right)$$

$$\left(260 + \frac{270^2 \times 10^{-3}}{2} \right) + 0.0190 \times 44500 - 21$$

$$= 1.0190 \left(912 + \frac{V_g^2 \times 10^{-3}}{2} + 0.05 \frac{0.019}{1.019} \times 44500 \right)$$

$$260 + 36.5 + 845 - 21 = 1.019 \left(912 + \frac{V_g^2 \times 10^{-3}}{2} + 42 \right)$$

$$\therefore \frac{V_g^2}{2} = 156 \times 10^3 \text{ m}^2/\text{s}^2$$

$$V_g = \sqrt{31.2} \times 100 \text{ m/s}$$

Velocity of exhaust gas, $V_g = 560 \text{ m/s}$

Ans.

Example 5.7 In a reciprocating engine, the mass of gas occupying the clearance volume is m_c kg at state p_1, u_1, v_1 and h_1 . By opening the inlet valve, m_f kg of gas is taken into the cylinder, and at the conclusion of the intake process the state of the gas is given by p_2, u_2, v_2, h_2 . The state of the gas in the supply pipe is constant and is given by p_p, u_p, v_p, h_p, V_p . How much heat is transferred between the gas and the cylinder walls during the intake process?

Solution Let us consider the control volume as shown in Fig. Ex. 5.7. Writing the energy balance on a time rate basis

$$\frac{dE_v}{d\tau} = \frac{dQ}{d\tau} - \frac{dW}{d\tau} + \left(h_p + \frac{V_p^2}{2} \right) \frac{dm}{d\tau}$$

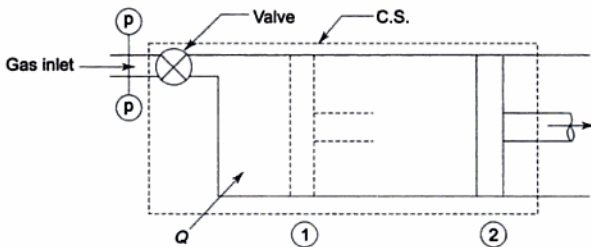

Fig. Ex. 5.7

With h_p and V_p being constant, the above equation can be integrated to give for the total process

$$\Delta E_v = Q - W + \left(h_p + \frac{V_p^2}{2} \right) m_f$$

Now

$$\Delta E_v = U_2 - U_1 = (m_c + m_f) u_2 - m_c u_1$$

$$\therefore Q = (m_c + m_f) u_2 - m_c u_1 - m_f \left(h_p + \frac{V_p^2}{2} \right) + W \quad \text{Ans.}$$

Example 5.8 The internal energy of air is given by

$$u = u_0 + 0.718t$$

where u is in kJ/kg, u_0 is any arbitrary value of u at 0°C , kJ/kg, and t is the temperature in $^\circ\text{C}$. Also for air, $p_v = 0.287(t + 273)$, where p is in kPa and v is in m^3/kg .

A mass of air is stirred by a paddle wheel in an insulated constant volume tank. The velocities due to stirring make a negligible contribution to the internal energy of the air. Air flows out through a small valve in the tank at a rate controlled to keep the temperature in the tank constant. At a certain instant the conditions are as follows: tank volume 0.12 m^3 , pressure 1 MPa, temperature 150°C , and power to paddle wheel 0.1 kW . Find the rate of flow of air out of the tank at this instant. *Solution* Writing the energy balance for the control volume as shown in Fig. Ex. 5.8

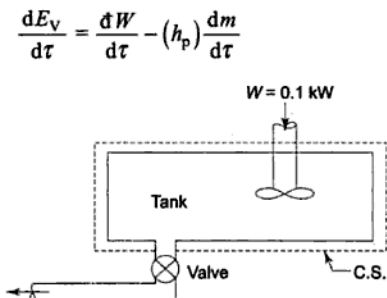

Fig. Ex. 5.8

Since there is no change in internal energy of air in the tank,

$$h_p \cdot \frac{dm}{d\tau} = \frac{dW}{d\tau}$$

where

$$h_p = u + pv.$$

Let

$$u = 0 \text{ at } t = 0 \text{ K} = -273^\circ\text{C}$$

$$u = u_0 + 0.718 t$$

$$0 = u_0 + 0.718 (-273)$$

$$u_0 = 0.718 \times 273 \text{ kJ/kg}$$

At $t^\circ\text{C}$

$$u = 0.718 \times 273 + 0.718 t$$

$$= 0.718 \times (t + 273) \text{ kJ/kg}$$

$$h_p = 0.718 (t + 273) + 0.287 (t + 273)$$

or

$$h_p = 1.005 (t + 273)$$

At 150°C

$$h_p = 1.005 \times 423$$

$$= 425 \text{ kJ/kg}$$

\therefore

$$\frac{dm}{d\tau} = \frac{1}{h_p} \frac{dW}{d\tau}$$

$$\begin{aligned}
 &= \frac{0.1 \text{ kJ/s}}{425 \text{ kJ/kg}} = 0.236 \times 10^{-3} \text{ kg/s} \\
 &= 0.845 \text{ kg/h}
 \end{aligned}$$

This is the rate at which air flows out of the tank.

Example 5.9 A well-insulated vessel of volume V contains a gas at pressure p_0 and temperature t_0 . The gas from a main at a uniform temperature t_1 is pumped into the vessel and the inflow rate decreases exponentially with time according to $\dot{m} = \dot{m}_0 e^{-a\tau}$, where a is a constant. Determine the pressure and temperature of the gas in the vessel as a function of time. Neglect the K.E. of the gas entering the vessel and assume that the gas follows the relation

$$pv = RT, \text{ where } T = t + 273$$

and its specific heats are constant.

- If the vessel was initially evacuated, show that the temperature inside the vessel is independent of time.
- Determine the charging time when the pressure inside the vessel reaches that of the main.

Solution Since the vessel is well-insulated, $\dot{Q} = 0$ and there is no external work transfer, $\dot{W} = C$. Therefore,

$$\frac{dE_V}{d\tau} = h_1 \frac{dm}{d\tau} = h_1 \dot{m}_0 e^{-a\tau}$$

where h_1 is the enthalpy of the gas in the main.

On integration,

$$E = E_0 + \frac{h_1 \dot{m}_0}{a} (1 - e^{-a\tau})$$

where E_0 is the initial energy of the vessel at the beginning of the charging process, i.e. $E = E_0$ at $\tau = 0$. Neglecting K.E. and P.E. changes, by energy balance

$$Mu = M_0 u_0 + \frac{\dot{m}_0}{a} (1 - e^{-a\tau}) (u_1 + p_1 v_1) \quad (1)$$

Again,

$$\frac{dm}{d\tau} = \dot{m}_0 e^{-a\tau}$$

On integration,

$$M = M_0 + \frac{\dot{m}_0 (1 - e^{-a\tau})}{a} \quad (2)$$

where M_0 is the initial mass of the gas. Eliminating M from Eqs (1) and (2),

$$\begin{aligned}
 &\left\{ M_0 + \frac{\dot{m}_0}{a} (1 - e^{-a\tau}) \right\} u - M_0 u_0 \\
 &= \frac{\dot{m}_0}{a} (1 - e^{-a\tau}) (u_1 + RT_1)
 \end{aligned}$$

$$M_0 c_v (T - T_0) = \frac{\dot{m}_0}{a} (1 - e^{-a\tau}) \{c_v(T_1 - T) + RT_1\}$$

$$\therefore T = \frac{M_0 c_v T_0 + \frac{\dot{m}_0}{a} (1 - e^{-a\tau}) c_p T_1}{\left\{ M_0 + \frac{\dot{m}_0}{a} (1 - e^{-a\tau}) \right\} c_v}$$

$$p = \frac{MRT}{V} = \frac{R}{Vc_v} \left\{ M_0 c_v T_0 + \frac{\dot{m}_0}{a} (1 - e^{-a\tau}) c_p T_1 \right\}$$

$$= p_0 + \frac{\dot{m}_0 R}{aV} (1 - e^{-a\tau}) \gamma T_1$$

The above two equations show the temperature and pressure of the gas in the vessel as functions of time.

- (i) If $M_0 = 0$, $T = \gamma T_1$, i.e., the temperature inside the vessel becomes independent of time and is equal to γT_1 throughout the charging process.
- (ii) The charging process will stop when pressure inside the vessel reaches that of the main. The charging time can be found by setting $p = p_1$ in the pressure relation

$$p_1 - p_0 = \frac{\dot{m}_0 R \gamma T_1}{aV} - \frac{\dot{m}_0 R}{aV} e^{-a\tau} \gamma T_1$$

By rearrangement,

$$e^{a\tau} = \frac{\dot{m}_0 R \gamma T_1 / (aV)}{\left(\frac{\dot{m}_0 R \gamma T_1}{aV} \right) - (p_1 - p_0)}$$

$$\therefore \tau = -\frac{1}{a} \ln \left[1 - (p_1 - p_0) \frac{aV}{\dot{m}_0 R \gamma T_1} \right]$$

REVIEW QUESTIONS

- 5.1 Explain the system approach and the control volume approach in the analysis of a flow process.
- 5.2 What is a steady flow process? What is steady state?
- 5.3 Write the steady flow energy equation for a single stream entering and a single stream leaving a control volume and explain the various terms in it.
- 5.4 Give the differential form of the S.F.E.E.
- 5.5 Under what conditions does the S.F.E.E. reduce to Euler's equation?
- 5.6 How does Bernoulli's equation compare with S.F.E.E.?
- 5.7 What will be the velocity of a fluid leaving a nozzle, if the velocity of approach is very small?
- 5.8 Show that the enthalpy of a fluid before throttling is equal to that after throttling.
- 5.9 Write the general energy equation for a variable flow process.
- 5.10 What is the system technique in a bottle-filling process?
- 5.11 Explain the control volume technique in a variable flow process.

PROBLEMS

- 5.1 A blower handles 1 kg/s of air at 20°C and consumes a power of 15 kW. The inlet and outlet velocities of air are 100 m/s and 150 m/s respectively. Find the exit air temperature, assuming adiabatic conditions. Take c_p of air as 1.005 kJ/kg-K.

Ans. 28.38°C

- 5.2 A turbine operates under steady flow conditions, receiving steam at the following state: pressure 1.2 MPa, temperature 188°C, enthalpy 2785 kJ/kg, velocity 33.3 m/s and elevation 3 m. The steam leaves the turbine at the following state: pressure 20 kPa, enthalpy 2512 kJ/kg, velocity 100 m/s, and elevation 0 m. Heat is lost to the surroundings at the rate of 0.29 kJ/s. If the rate of steam flow through the turbine is 0.42 kg/s, what is the power output of the turbine in kW?

Ans. 112.51 kW

- 5.3 A nozzle is a device for increasing the velocity of a steadily flowing stream. At the inlet to a certain nozzle, the enthalpy of the fluid passing is 3000 kJ/kg and the velocity is 60 m/s. At the discharge end, the enthalpy is 2762 kJ/kg. The nozzle is horizontal and there is negligible heat loss from it. (a) Find the velocity at exit from the nozzle. (b) If the inlet area is 0.1 m² and the specific volume at inlet is 0.187 m³/kg, find the mass flow rate. (c) If the specific volume at the nozzle exit is 0.498 m³/kg, find the exit area of the nozzle.

Ans. (a) 692.5 m/s, (b) 32.08 kg/s (c) 0.023 m²

- 5.4 In an oil cooler, oil flows steadily through a bundle of metal tubes submerged in a steady stream of cooling water. Under steady flow conditions, the oil enters at 90°C and leaves at 30°C, while the water enters at 25°C and leaves at 70°C. The enthalpy of oil at t °C is given by

$$h = 1.68 t + 10.5 \times 10^{-4} t^2 \text{ kJ/kg}$$

What is the cooling water flow required for cooling 2.78 kg/s of oil?

Ans. 1.473 kg/s

- 5.5 A thermoelectric generator consists of a series of semiconductor elements (Fig. P. 5.5), heated on one side and cooled on the other. Electric current flow is produced as a result of energy transfer as heat. In a particular experiment the

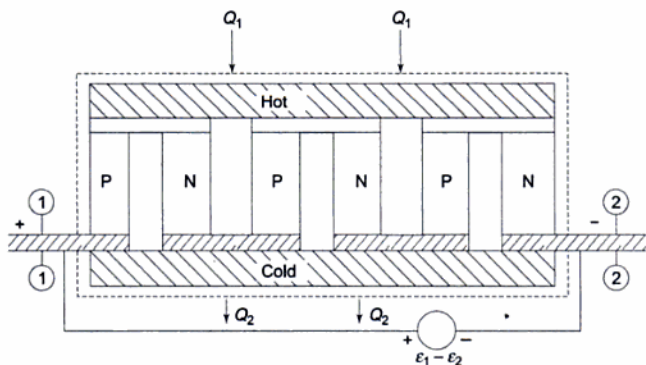

Fig. P.5.5

current was measured to be 0.5 amp and the electrostatic potential at (1) was 0.8 volt above that at (2). Energy transfer as heat to the hot side of the generator was taking place at a rate of 5.5 watts. Determine the rate of energy transfer as heat from the cold side and the energy conversion efficiency.

Ans. $Q_2 = 5.1$ watts, $\eta = 0.073$

- 5.6 A turbocompressor delivers $2.33 \text{ m}^3/\text{s}$ of air at 0.276 MPa, 43°C which is heated at this pressure to 430°C and finally expanded in a turbine which delivers 1860 kW. During the expansion, there is a heat transfer of 0.09 MJ/s to the surroundings. Calculate the turbine exhaust temperature if changes in kinetic and potential energy are negligible. Take $c_p = 1.005 \text{ kJ/kgK}$

Ans. 157°C

- 5.7 A reciprocating air compressor takes in $2 \text{ m}^3/\text{min}$ at 0.11 MPa, 20°C which it delivers at 1.5 MPa, 111°C to an aftercooler where the air is cooled at constant pressure to 25°C . The power absorbed by the compressor is 4.15 kW. Determine the heat transfer in (a) the compressor, and (b) the cooler. State your assumptions.

Ans. -0.17 kJ/s , -3.76 kJ/s .

- 5.8 In a water cooling tower air enters at a height of 1 m above the ground level and leaves at a height of 7 m. The inlet and outlet velocities are 20 m/s and 30 m/s respectively. Water enters at a height of 8 m and leaves at a height of 0.8 m. The velocity of water at entry and exit are 3 m/s and 1 m/s respectively. Water temperatures are 80°C and 50°C at the entry and exit respectively. Air temperatures are 30°C and 70°C at the entry and exit respectively. The cooling tower is well insulated and a fan of 2.25 kW drives the air through the cooler. Find the amount of air per second required for 1 kg/s of water flow. The values of c_p of air and water are 1.005 and $4.187/\text{kg K}$ respectively.

Ans. 3.16 kg

- 5.9 Air at 101.325 kPa, 20°C is taken into a gas turbine power plant at a velocity of 140 m/s through an opening of 0.15 m^2 cross-sectional area. The air is compressed heated, expanded through a turbine, and exhausted at 0.18 MPa, 150°C through an opening of 0.10 m^2 cross-sectional area. The power output is 375 kW. Calculate the net amount of heat added to the air in kJ/kg. Assume that air obeys the law $pv = 0.287 (t + 273)$ where p is the pressure in kPa v is the specific volume in m^3/kg , and t is the temperature in $^\circ\text{C}$. Take $c_p = 1.005 \text{ kJ/kg K}$.

Ans. 150.23 kJ/kg

- 5.10 A gas flows steadily through a rotary compressor. The gas enters the compressor at a temperature of 16°C , a pressure of 100 kPa, and an enthalpy of 391.2 kJ/kg. The gas leaves the compressor at a temperature of 245°C , a pressure of 0.6 MPa, and an enthalpy of 534.5 kJ/kg. There is no heat transfer to or from the gas as it flows through the compressor. (a) Evaluate the external work done per unit mass of gas assuming the gas velocities at entry and exit to be negligible. (b) Evaluate the external work done per unit mass of gas when the gas velocity at entry is 80 m/s and that at exit is 160 m/s.

Ans. 143.3 kJ/kg , 152.9 kJ/kg

- 5.11 The steam supply to an engine comprises two streams which mix before entering the engine. One stream is supplied at the rate of 0.01 kg/s with an enthalpy of 2952 kJ/kg and a velocity of 20 m/s. The other stream is supplied at the rate of 0.1 kg/s with an enthalpy of 2569 kJ/kg and a velocity of 120 m/s. At the exit

from the engine the fluid leaves as two streams, one of water at the rate of 0.001 kg/s with an enthalpy of 420 kJ/kg and the other of steam; the fluid velocities at the exit are negligible. The engine develops a shaft power of 25 kW. The heat transfer is negligible. Evaluate the enthalpy of the second exit stream.

Ans. 2401 kJ/kg

- 5.12 The stream of air and gasoline vapour, in the ratio of 14:1 by mass, enters a gasoline engine at a temperature of 30°C and leaves as combustion products at a temperature of 790°C. The engine has a specific fuel consumption of 0.3 kg/kWh. The net heat transfer rate from the fuel-air steam to the jacket cooling water and to the surroundings is 35 kW. The shaft power delivered by the engine is 26 kW. Compute the increase in the specific enthalpy of the fuel-air stream, assuming the changes in kinetic energy and in elevation to be negligible.

Ans. - 1877 kJ/kg mixture

- 5.13 An air turbine forms part of an aircraft refrigerating plant. Air at a pressure of 295 kPa and a temperature of 58°C flows steadily into the turbine with a velocity of 45 m/s. The air leaves the turbine at a pressure of 115 kPa, a temperature of 2°C, and a velocity of 150 m/s. The shaft work delivered by the turbine is 54 kJ/kg of air. Neglecting changes in elevation, determine the magnitude and sign of the heat transfer per unit mass of air flowing. For air, take $c_p = 1.005$ kJ/kg K and the enthalpy $h = c_p t$.

Ans. + 7.96 kJ/kg

- 5.14 In a turbomachine handling an incompressible fluid with a density of 1000 kg/m³ the conditions of the fluid at the rotor entry and exit are as given below

	Inlet	Exit
Pressure	1.15 MPa	0.05 MPa
Velocity	30 m/s	15.5 m/s
Height above datum	10 m	2 m

If the volume flow rate of the fluid is 40 m³/s, estimate the net energy transfer from the fluid as work.

Ans. 60.3 MW

- 5.15 A room for four persons has two fans, each consuming 0.18 kW power, and three 100 W lamps. Ventilation air at the rate of 80 kg/h enters with an enthalpy of 84 kJ/kg and leaves with an enthalpy of 59 kJ/kg. If each person puts out heat at the rate of 630 kg/h determine the rate at which heat is to be removed by a room cooler, so that a steady state is maintained in the room.

Ans. 1.92 kW

- 5.16 Air flows steadily at the rate of 0.4 kg/s through an air compressor, entering at 6 m/s with a pressure of 1 bar and a specific volume of 0.85 m³/kg, and leaving at 4.5 m/s with a pressure of 6.9 bar and a specific volume of 0.16 m³/kg. The internal energy of the air leaving is 88 kJ/kg greater than that of the air entering. Cooling water in a jacket, surrounding the cylinder absorbs heat from the air at the rate of 59 W. Calculate the power required to drive the compressor and the inlet and outlet cross-sectional areas.

(Ans. 45.4 kW, 0.057 m², 0.0142 m²)

- 5.17 Steam flowing in a pipeline is at a steady state represented by p_p, t_p, u_p, v_p, h_p and V_p . A small amount of the total flow is led through a small tube to an evacuated chamber which is allowed to fill slowly until the pressure is equal to the pipeline

pressure. If there is no heat transfer, derive an expression for the final specific internal energy in the chamber, in terms of the properties in the pipeline.

- 5.18 The internal energy of air is given, at ordinary temperatures, by

$$u = u_0 + 0.718 t$$

where u is in kJ/kg, u_0 is any arbitrary value of u at 0°C , kJ/kg, and t is temperature in $^\circ\text{C}$.

Also for air, $p v = 0.287 (t + 273)$

where p is in kPa and v is in m^3/kg .

- (a) An evacuated bottle is fitted with a valve through which air from the atmosphere, at 760 mm Hg and 25°C , is allowed to flow slowly to fill the bottle. If no heat is transferred to or from the air in the bottle, what will its temperature be when the pressure in the bottle reaches 760 mm Hg?
Ans. 144.2°C
- (b) If the bottle initially contains 0.03 m^3 of air at 400 mm Hg and 25°C , what will the temperature be when the pressure in the bottle reaches 760 mm Hg?
Ans. 71.6°C
- 5.19 A pressure cylinder of volume V contains air at pressure p_0 and temperature T_0 . It is to be filled from a compressed air line maintained at constant pressure p_1 and temperature T_1 . Show that the temperature of the air in the cylinder after it has been charged to the pressure of the line is given by

$$T = \frac{\gamma T_1}{1 + \frac{p_0}{p_1} \left(\gamma \frac{T_1}{T_0} - 1 \right)}$$

- 5.20 A small reciprocating vacuum pump having the rate of volume displacement V_d is used to evacuate a large vessel of volume V . The air in the vessel is maintained at a constant temperature T by energy transfer as heat. If the initial and final pressures are p_1 and p_2 respectively, find the time taken for the pressure drop and the necessary energy transfer as heat during evacuation. Assume that for air, $pV = mRT$, where m is the mass and R is a constant, and u is a function of T only.

$$\left[\text{Ans. } t = \frac{V}{V_d} \ln \frac{p_1}{p_2}; Q = (p_1 - p_2) V \right]$$

[Hint: $dm = -p(V_d dt)/(RT) = V dp/(RT)$].

- 5.21 A tank containing 45 kg of water initially at 45°C has one inlet and one exit with equal mass flow rates. Liquid water enters at 45°C and a mass flow rate of 270 kg/h. A cooling coil immersed in the water removes energy at a rate of 7.6 kW. The water is well mixed by a paddle wheel with a power input of 0.6 kW. The pressures at inlet and exit are equal. Ignoring changes in KE and PE, find the variation of water temperature with time.

$$\text{Ans. } T = 318 - 22 [1 - \exp(-6t)]$$

- 5.22 A rigid tank of volume 0.5 m^3 is initially evacuated. A tiny hole develops in the wall, and air from the surroundings at 1 bar, 21°C leaks in. Eventually, the pressure in the tank reaches 1 bar. The process occurs slowly enough that heat transfer between the tank and the surroundings keeps the temperature of the air inside the tank constant at 21°C . Determine the amount of heat transfer.

$$\text{Ans. } -50 \text{ kJ}$$

6

Second Law of Thermodynamics

6.1 Qualitative Difference between Heat and Work

The first law of thermodynamics states that a certain energy balance will hold when a system undergoes a change of state or a thermodynamic process. But it does not give any information on whether that change of state or the process is at all feasible or not. The first law cannot indicate whether a metallic bar of uniform temperature can spontaneously become warmer at one end and cooler at the other. All that the law can state is that if this process did occur, the energy gained by one end would be exactly equal to that lost by the other. *It is the second law of thermodynamics which provides the criterion as to the probability of various processes.*

Spontaneous processes in nature occur only in one direction. Heat always flows from a body at a higher temperature to a body at a lower temperature, water always flows downward, time always flows in the forward direction. The reverse of these never happens spontaneously. The spontaneity of the process is due to a finite driving potential, sometimes called the 'force' or the 'cause', and what happens is called the 'flux', the 'current' or the 'effect'. The typical forces like temperature gradient, concentration gradient, and electric potential gradient, have their respective conjugate fluxes of heat transfer, mass transfer, and flow of electric current. These transfer processes can never spontaneously occur from a lower to a higher potential. This directional law puts a limitation on energy transformation other than that imposed by the first law.

Joule's experiments (Article 4.1) amply demonstrate that energy, when supplied to a system in the form of work, can be completely converted into heat (work transfer \rightarrow internal energy increase \rightarrow heat transfer). But the complete conversion of heat into work in a cycle is not possible. So *heat and work are not completely interchangeable forms of energy.*

When work is converted into heat, we always have

$$W \Rightarrow Q$$

but when heat is converted into work in a complete closed cycle process

$$Q \not\Rightarrow W$$

The arrow indicates the direction of energy transformation. This is illustrated in Fig. 6.1. As shown in Fig. 6.1(a), a system is taken from state 1 to state 2 by work transfer W_{1-2} , and then by heat transfer Q_{2-1} the system is brought back from state 2 to state 1 to complete a cycle. It is always found that $W_{1-2} = Q_{2-1}$. But if the system is taken from state 1 to state 2 by heat transfer Q_{1-2} , as shown in Fig. 6.1(b), then the system cannot be brought back from state 2 to state 1 by work transfer W_{2-1} . Hence, heat cannot be converted completely and continuously into work in a cycle. Some heat has to be rejected. In Fig. 6.1(b), W_{2-3} is the work done and Q_{3-1} is the heat rejected to complete the cycle. This underlies the work of Sadi Carnot, a French military engineer, who first studied this aspect of energy transformation (1824). Work is said to be a *high grade energy* and heat a *low grade energy*. *The complete conversion of low grade energy into high grade energy in a cycle is impossible.*

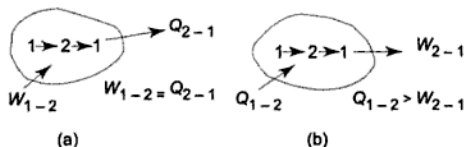

Fig. 6.1 Qualitative distinction between heat and work

6.2 Cyclic Heat Engine

For engineering purposes, the second law is best expressed in terms of the conditions which govern the production of work by a thermodynamic system operating in a cycle.

A heat engine cycle is a thermodynamic cycle in which there is a net heat transfer to the system and a net work transfer from the system. The system which executes a heat engine cycle is called a *heat engine*.

A heat engine may be in the form of a mass of gas confined in a cylinder and piston machine (Fig. 6.2a) or a mass of water moving in a steady flow through a steam power plant (Fig. 6.2b).

In the cyclic heat engine, as represented in Fig. 6.2(a), heat Q_1 is transferred to the system, work W_E is done by the system, work W_C is done upon the system, and then heat Q_2 is rejected from the system. The system is brought back to the initial state through all these four successive processes which constitute a heat engine cycle. In Fig. 6.2(b) heat Q_1 is transferred from the furnace to the water in the

boiler to form steam which then works on the turbine rotor to produce work W_T , then the steam is condensed to water in the condenser in which an amount Q_2 is rejected from the system, and finally work W_p is done on the system (water) to pump it to the boiler. The system repeats the cycle.

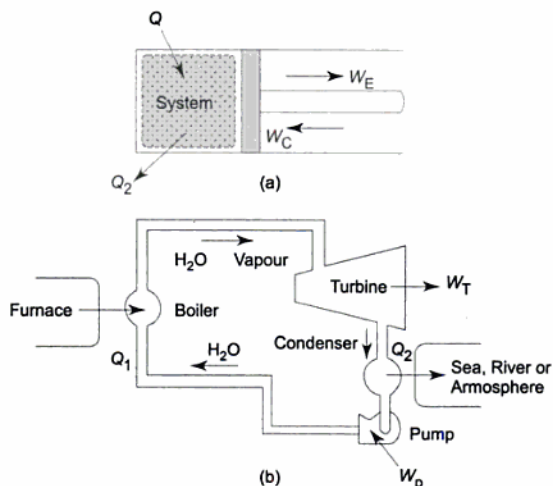

Fig. 6.2 Cyclic heat engine

- (a) Heat engine cycle performed by a closed system undergoing four successive energy interactions with the surroundings
 (b) Heat engine cycle performed by a steady flow system interacting with the surroundings as shown

The net heat transfer in a cycle to either of the heat engines

$$Q_{\text{net}} = Q_1 - Q_2 \quad (6.1)$$

and the net work transfer in a cycle

$$W_{\text{net}} = W_T - W_p \quad (6.2)$$

(or $W_{\text{net}} = W_E - W_C$)

By the first law of thermodynamics, we have

$$\sum_{\text{cycle}} Q = \sum_{\text{cycle}} W$$

$$\therefore Q_{\text{net}} = W_{\text{net}}$$

or $Q_1 - Q_2 = W_T - W_p \quad (6.3)$

Figure 6.3 represents a cyclic heat engine in the form of a block diagram indicating the various energy interactions during a cycle. Boiler (B), turbine (T), condenser (C), and pump (P), all four together constitute a heat engine. A heat engine

is here a certain quantity of water undergoing the energy interactions, as shown, in cyclic operations to produce net work from a certain heat input.

The function of a heat engine cycle is to produce work continuously at the expense of heat input to the system. So the net work W_{net} and heat input Q_1 referred to the cycle are of primary interest. The efficiency of a heat engine or a heat engine cycle is defined as

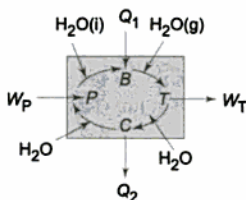

Fig. 6.3 Cyclic heat engine with energy interactions represented in a block diagram

$$\eta = \frac{\text{Net work output of the cycle}}{\text{Total heat input to the cycle}}$$

$$= \frac{W_{\text{net}}}{Q_1} \quad (6.4)$$

From Eqs (6.1), (6.2), (6.3), and (6.4)

$$\eta = \frac{W_{\text{net}}}{Q_1} = \frac{W_T - W_P}{Q_1} = \frac{Q_1 - Q_2}{Q_1}$$

$$\eta = 1 - \frac{Q_2}{Q_1} \quad (6.5)$$

This is also known as the *thermal efficiency* of a heat engine cycle. A heat engine is very often called upon to extract as much work (net) as possible from a certain heat input, i.e., to maximize the cycle efficiency.

6.3 Energy Reservoirs

A thermal energy reservoir (TER) is defined as a large body of infinite heat capacity, which is capable of absorbing or rejecting an unlimited quantity of heat without suffering appreciable changes in its thermodynamic coordinates. The changes that do take place in the large body as heat enters or leaves are so very slow and so very minute that all processes within it are quasi-static.

The thermal energy reservoir TER_H from which heat Q_1 is transferred to the system operating in a heat engine cycle is called the *source*. The thermal energy reservoir TER_L to which heat Q_2 is rejected from the system during a cycle is the *sink*. A typical source is a constant temperature furnace where fuel is continuously burnt, and a typical sink is a river or sea or the atmosphere itself.

A mechanical energy reservoir (MER) is a large body enclosed by an adiabatic impermeable wall capable of storing work as potential energy (such as a raised weight or wound spring) or kinetic energy (such as a rotating flywheel). All processes of interest within an MER are essentially quasi-static. An MER receives and delivers mechanical energy quasi-statically.

Figure 6.4 shows a cyclic heat engine exchanging heat with a source and a sink and delivering W_{net} in a cycle to an MER.

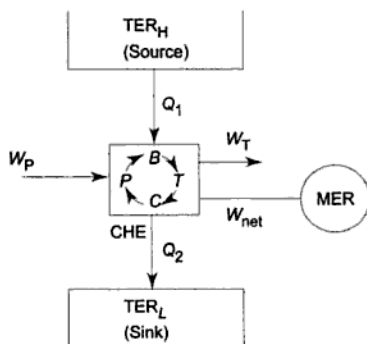

Fig. 6.4 Cyclic heat engine (CHE) with source and sink

6.4 Kelvin-Planck Statement of Second Law

The efficiency of a heat engine is given by

$$\eta = \frac{W_{\text{net}}}{Q_1} = 1 - \frac{Q_2}{Q_1}$$

Experience shows that $W_{\text{net}} < Q_1$, since heat Q_1 transferred to a system cannot be completely converted to work in a cycle (Article 6.1). Therefore, η is less than unity. A heat engine can never be 100% efficient. Therefore, $Q_2 > 0$, i.e., there has always to be a heat rejection. To produce net work in a thermodynamic cycle, a heat engine has thus to exchange heat with two reservoirs, the source and the sink.

The *Kelvin-Planck statement* of the second law states: *It is impossible for a heat engine to produce net work in a complete cycle if it exchanges heat only with bodies at a single fixed temperature.*

If $Q_2 = 0$ (i.e., $W_{\text{net}} = Q_1$, or $\eta = 1.00$), the heat engine will produce net work in a complete cycle by exchanging heat with only one reservoir, thus violating the Kelvin-Planck statement (Fig. 6.5). Such a heat engine is called a *perpetual motion machine of the second kind*, abbreviated to PMM2. A PMM2 is impossible.

A heat engine has, therefore, to exchange heat with two thermal energy reservoirs at two different temperatures to produce net work in a complete cycle (Fig. 6.6). So long as there is a difference in temperature, motive power (i.e. work) can be produced. If the bodies with which the heat engine exchanges heat are of finite heat capacities, work will be produced by the heat engine till the temperatures of the two bodies are equalized.

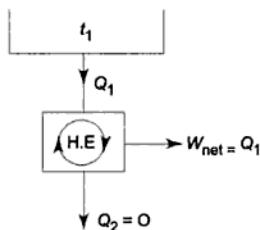

Fig. 6.5 A PMM2

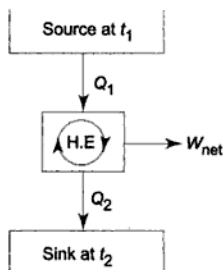

Fig. 6.6 Heat engine producing net work in a cycle by exchanging heat at two different temperatures

If the second law were not true, it would be possible to drive a ship across the ocean by extracting heat from the ocean or to run a power plant by extracting heat from the surrounding air. Neither of these impossibilities violates the first law of thermodynamics. Both the ocean and the surrounding air contain an enormous store of internal energy, which, in principle, may be extracted in the form of a flow of heat. There is nothing in the first law to preclude the possibility of converting this heat completely into work. The second law is, therefore, a separate law of nature, and not a deduction of the first law. The first law denies the possibility of creating or destroying energy; the second denies the possibility of utilizing energy in a particular way. The continual operation of a machine that creates its own energy and thus violates the first law is called the PMM1. The operation of a machine that utilizes the internal energy of only one TER, thus violating the second law, is called the PMM2.

6.5 Clausius' Statement of the Second Law

Heat always flows from a body at a higher temperature to a body at a lower temperature. The reverse process never occurs spontaneously.

Clausius' statement of the second law gives: *It is impossible to construct a device which, operating in a cycle, will produce no effect other than the transfer of heat from a cooler to a hotter body.*

Heat cannot flow of itself from a body at a lower temperature to a body at a higher temperature. Some work must be expended to achieve this.

6.6 Refrigerator and Heat Pump

A *refrigerator* is a device which, operating in a cycle, maintains a body at a temperature lower than the temperature of the surroundings. Let the body A (Fig. 6.7) be maintained at t_2 , which is lower than the ambient temperature t_1 . Even though A is insulated, there will always be heat leakage Q_2 into the body

from the surroundings by virtue of the temperature difference. In order to maintain, body A at the constant temperature t_2 , heat has to be removed from the body at the same rate at which heat is leaking into the body. This heat (Q_2) is absorbed by a working fluid, called the refrigerant, which evaporates in the evaporator E_1 at a temperature lower than t_2 absorbing the latent heat of vaporization from the body A which is cooled or refrigerated (Process 4–1). The vapour is first compressed in the compressor C_1 driven by a motor which absorbs work W_C (Process 1–2), and is then condensed in the condenser C_2 rejecting the latent heat of condensation Q_1 at a temperature higher than that of the atmosphere (at t_1) for heat transfer to take place (Process 2–3). The condensate then expands adiabatically through an expander (an engine or turbine) producing work W_E , when the temperature drops to a value lower than t_2 such that heat Q_2 flows from the body A to make the refrigerant evaporate (Process 3–4). Such a cyclic device of flow through E_1 – C_1 – C_2 – E_2 is called a *refrigerator*. In a refrigerator cycle, attention is concentrated on the body A . Q_2 and W are of primary interest. Just like efficiency in a heat engine cycle, there is a performance parameter in a refrigerator cycle, called the *coefficient of performance*, abbreviated to COP, which is defined as

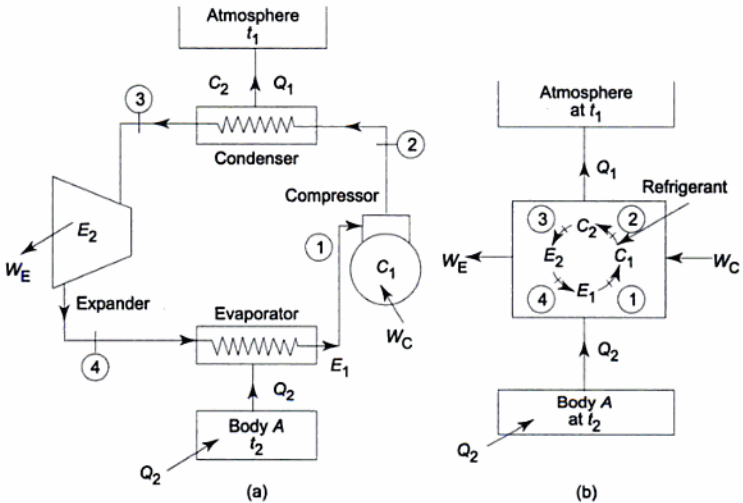

Fig. 6.7 A cyclic refrigeration plant

$$\text{COP} = \frac{\text{Desired effect}}{\text{Work input}} = \frac{Q_2}{W}$$

$$\therefore [\text{COP}]_{\text{ref}} = \frac{Q_2}{Q_1 - Q_2} \tag{6.6}$$

A *heat pump* is a device which, operating in a cycle, maintains a body, say *B* (Fig. 6.8), at a temperature higher than the temperature of the surroundings. By virtue of the temperature difference, there will be heat leakage Q_1 from the body to the surroundings. The body will be maintained at the constant temperature t_1 , if heat is discharged into the body at the same rate at which heat leaks out of the body. The heat is extracted from the low temperature reservoir, which is nothing but the atmosphere, and discharged into the high temperature body *B*, with the expenditure of work W in a cyclic device called a heat pump. The working fluid operates in a cycle flowing through the evaporator E_1 , compressor C_1 , condenser C_2 and expander E_2 , similar to a refrigerator, but the attention is here focussed on the high temperature body *B*. Here Q_1 and W are of primary interest, and the COP is defined as

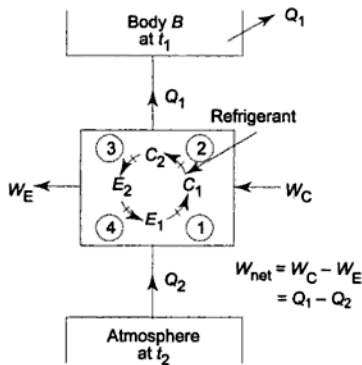

Fig. 6.8 A cyclic heat pump

$$\text{COP} = \frac{Q_1}{W}$$

$$\therefore [\text{COP}]_{\text{H.P.}} = \frac{Q_1}{Q_1 - Q_2} \quad (6.7)$$

From equations (6.6) and (6.7), it is found that

$$[\text{COP}]_{\text{H.P.}} = [\text{COP}]_{\text{ref}} + 1 \quad (6.8)$$

The COP of a heat pump is greater than the COP of a refrigerator by unity. Equation (6.8) expresses a very interesting feature of a heat pump.

Since

$$Q_1 = [\text{COP}]_{\text{H.P.}} W = [\text{COP}_{\text{ref}} + 1] W \quad (6.9)$$

Q_1 is always greater than W .

For an electrical resistance heater, if W is the electrical energy consumption, then the heat transferred to the space at steady state is W only, i.e., $Q_1 = W$.

A 1 kW electric heater can give 1 kW of heat at steady state and nothing more. In other words, 1 kW of work (high grade energy) dissipates to give 1 kW of heat (low grade energy), which is thermodynamically inefficient.

However, if this electrical energy W is used to drive the compressor of a heat pump, the heat supplied Q_1 will always be more than W , or $Q_1 > W$. Thus, a heat pump provides a thermodynamic advantage over direct heating.

For heat to flow from a cooler to a hotter body, W cannot be zero, and hence, the COP (both for refrigerator and heat pump) cannot be infinity. Therefore, $W > 0$, and $\text{COP} < \infty$.

6.7 Equivalence of Kelvin-Planck and Clausius Statements

At first sight, Kelvin-Planck's and Clausius' statements may appear to be unconnected, but it can easily be shown that they are virtually two parallel statements of the second law and are equivalent in all respects.

The equivalence of the two statements will be proved if it can be shown that the violation of one statement implies the violation of the second, and vice versa.

(a) Let us first consider a cyclic heat pump P which transfers heat from a low temperature reservoir (t_2) to a high temperature reservoir (t_1) with no other effect, i.e., with no expenditure of work, violating Clausius statement (Fig. 6.9).

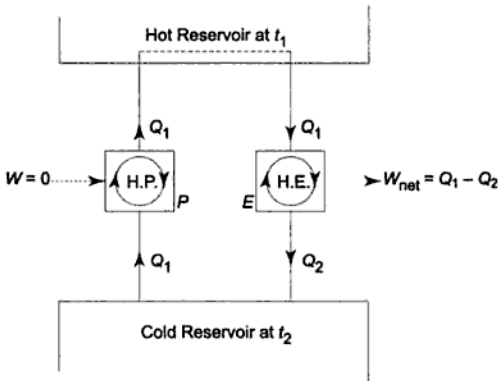

Fig. 6.9 Violation of the Clausius statement

Let us assume a cyclic heat engine E operating between the same thermal energy reservoirs, producing W_{net} in one cycle. The rate of working of the heat engine is such that it draws an amount of heat Q_1 from the hot reservoir equal to that discharged by the heat pump. Then the hot reservoir may be eliminated and the heat Q_1 discharged by the heat pump is fed to the heat engine. So we see that the heat pump P and the heat engine E acting together constitute a heat engine

operating in cycles and producing net work while exchanging heat only with one body at a single fixed temperature. This violates the Kelvin-Planck statement.

(b) Let us now consider a perpetual motion machine of the second kind (E) which produces net work in a cycle by exchanging heat with only one thermal energy reservoir (at t_1) and thus violates the Kelvin-Planck statement (Fig. 6.10).

Let us assume a cyclic heat pump (P) extracting heat Q_2 from a low temperature reservoir at t_2 and discharging heat to the high temperature reservoir at t_1 with the expenditure of work W equal to what the PMM2 delivers in a complete cycle. So E and P together constitute a heat pump working in cycles and producing the sole effect of transferring heat from a lower to a higher temperature body, thus violating the Clausius statement.

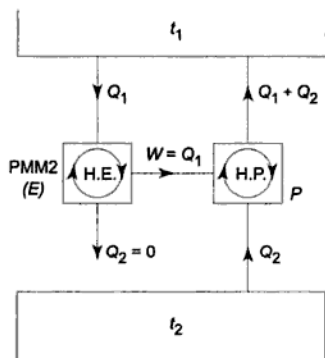

Fig. 6.10 Violation of the Kelvin-Planck statement

6.8 Reversibility and Irreversibility

The second law of thermodynamics enables us to divide all processes into two classes:

- Reversible or ideal process.
- Irreversible or natural process.

A *reversible* process is one which is performed in such a way that at the conclusion of the process, both the system and the surroundings may be restored to their initial states, without producing any changes in the rest of the universe. Let the state of a system be represented by A (Fig. 6.11), and let the system be taken to state B by following the path $A-B$. If the system and also the surroundings are restored to their initial states and no change in the universe is produced, then the process $A-B$ will be a reversible process. In the reverse process, the system has to be taken from state B to A by following the same path $B-A$. A reversible process should not leave any trace or relic to show that the process had ever occurred.

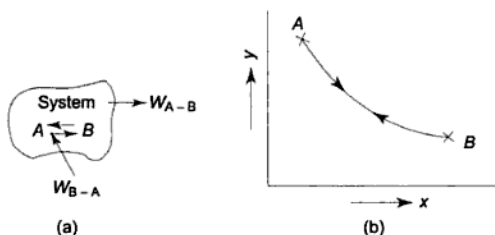

Fig. 6.11 Reversible process

A reversible process is carried out infinitely slowly with an infinitesimal gradient, so that every state passed through by the system is an equilibrium state. So a reversible process coincides with a quasi-static process.

Any natural process carried out with a finite gradient is an irreversible process. A reversible process, which consists of a succession of equilibrium states, is an idealized hypothetical process, approached only as a limit. It is said to be an asymptote to reality. All spontaneous processes are irreversible.

6.9 Causes of Irreversibility

Broken eggs, spilt milk, burnt boats, the wasted years of indolence that the locusts have eaten are merely proverbial metaphors for irreversibility.

The irreversibility of a process may be due to either one or both of the following:

- (a) Lack of equilibrium during the process.
- (b) Involvement of dissipative effects.

6.9.1 Irreversibility due to Lack of Equilibrium

The lack of equilibrium (mechanical, thermal or chemical) between the system and its surroundings, or between two systems, or two parts of the same system, causes a spontaneous change which is irreversible. The following are specific examples in this regard:

(a) Heat Transfer through a Finite Temperature Difference A heat transfer process approaches reversibility as the temperature difference between two bodies approaches zero. We define a reversible heat transfer process as one in which heat is transferred through an infinitesimal temperature difference. So to transfer a finite amount of heat through an infinitesimal temperature difference would require an infinite amount of time, or infinite area. All actual heat transfer processes are through a finite temperature difference and are, therefore, irreversible, and the greater the temperature difference, the greater is the irreversibility.

We can demonstrate by the second law that the heat transfer through a finite temperature difference is irreversible. Let us assume that a source at t_A and a sink

at t_B ($t_A > t_B$) are available, and let Q_{A-B} be the amount of heat flowing from A to B (Fig. 6.12). Let us assume an engine operating between A and B , taking heat Q_1 from A and discharging heat Q_2 to B . Let the heat transfer process be reversed, and Q_{B-A} be the heat flowing from B to A , and let the rate of working of the engine be such that

$$Q_2 = Q_{B-A}$$

(Fig. 6.13). Then the sink B may be eliminated. The net result is that E produces net work W in a cycle by exchanging heat only with A , thus violating the Kelvin-Planck statement. So the heat transfer process Q_{A-B} is irreversible, and Q_{B-A} is not possible.

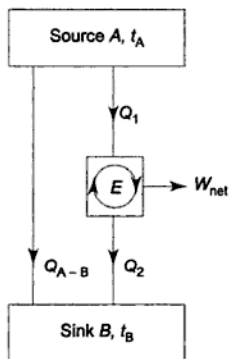

Fig. 6.12 Heat transfer through a finite temperature difference

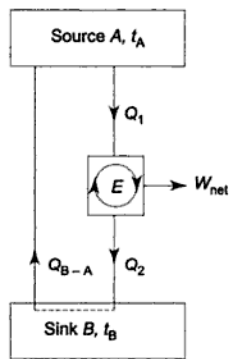

Fig. 6.13 Heat transfer through a finite temperature difference is irreversible

(b) Lack of Pressure Equilibrium within the Interior of the System or between the System and the Surroundings When there exists a difference in pressure between the system and the surroundings, or within the system itself, then both the system and its surroundings or the system alone, will undergo a change of state which will cease only when mechanical equilibrium is established. The reverse of this process is not possible spontaneously without producing any other effect. That the reverse process will violate the second law becomes obvious from the following illustration.

(c) Free Expansion Let us consider an insulated container (Fig. 6.14) which is divided into two compartments A and B by a thin diaphragm. Compartment A contains a mass of gas, while compartment B is completely evacuated. If the diaphragm is punctured, the gas in A will expand into B until the pressures in A and B become equal. This is known as free or unrestrained expansion. We can demonstrate by the second law, that the process of free expansion is irreversible.

To prove this, let us assume that free expansion is reversible, and that the gas in B returns into A with an increase in pressure, and B becomes evacuated as

before (Fig. 6.15). There is no other effect. Let us install an engine (a machine, not a cyclic heat engine) between A and B , and permit the gas to expand through the engine from A to B . The engine develops a work output W at the expense of the internal energy of the gas. The internal energy of the gas (system) in B can be restored to its initial value by heat transfer $Q (= W)$ from a source. Now, by the use of the reversed free expansion, the system can be restored to the initial state of high pressure in A and vacuum in B . The net result is a cycle, in which we observe that net work output W is accomplished by exchanging heat with a single reservoir. This violates the Kelvin-Planck statement. Hence, free expansion is irreversible.

The same argument will hold if the compartment B is not in vacuum but at a pressure lower than that in compartment A (case b).

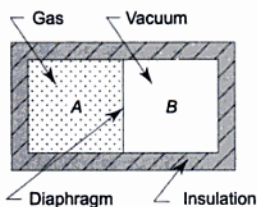

Fig. 6.14 Free expansion

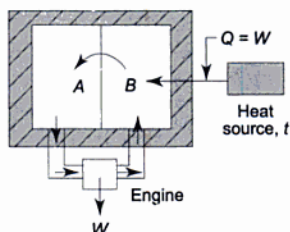

Fig. 6.15 Second law demonstrates that free expansion is irreversible

6.9.2 Irreversibility due to Dissipative Effects

The irreversibility of a process may be due to the *dissipative effects* in which work is done without producing an equivalent increase in the kinetic or potential energy of any system. The transformation of work into molecular internal energy either of the system or of the reservoir takes place through the agency of such phenomena as friction, viscosity, inelasticity, electrical resistance, and magnetic hysteresis. These effects are known as dissipative effects, and work is said to be dissipated. Dissipation of energy means the transition of ordered macroscopic motion into chaotic molecular motion, the reverse of which is not possible without violating second law.

(a) Friction Friction is always present in moving devices. Friction may be reduced by suitable lubrication, but it can never be completely eliminated. If this were possible, a movable device could be kept in continual motion without violating either of the two laws of thermodynamics. The continual motion of a movable device in the complete absence of friction is known as *perpetual motion of the third kind*.

That friction makes a process irreversible can be demonstrated by the second law. Let us consider a system consisting of a flywheel and a brake block (Fig. 6.16). The flywheel was rotating with a certain rpm, and it was brought to

rest by applying the friction brake. The distance moved by the brake block is very small, so work transfer is very nearly equal to zero. If the braking process occurs very rapidly, there is little heat transfer. Using suffix 2 after braking and suffix 1 before braking, and applying the first law, we have

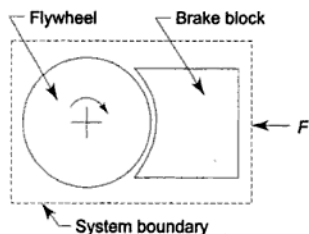

Fig. 6.16 Irreversibility due to dissipative effect like friction

$$Q_{1-2} = E_2 - E_1 + W_{1-2}$$

$$0 = E_2 - E_1 + 0$$

$$\therefore E_2 = E_1 \quad (6.10)$$

The energy of the system (isolated) remains constant. Since the energy may exist in the forms of kinetic, potential, and molecular internal energy, we have

$$U_2 + \frac{mV_2^2}{2} + mZ_2g = U_1 + \frac{mV_1^2}{2} + mZ_1g$$

Since the wheel is brought to rest, $V_2 = 0$, and there is no change in P.E.

$$U_2 = U_1 + \frac{mV_1^2}{2} \quad (6.11)$$

Therefore, the molecular internal energy of the system (i.e., of the brake and the wheel) increases by the absorption of the K.E. of the wheel. The reverse process, i.e., the conversion of this increase in molecular internal energy into K.E. within the system to cause the wheel to rotate is not possible. To prove it by the second law, let us assume that it is possible, and imagine the following cycle with three processes:

Process A: Initially, the wheel and the brake are at high temperature as a result of the absorption of the K.E. of the wheel, and the flywheel is at rest. Let the flywheel now start rotating at a particular rpm at the expense of the internal energy of the wheel and brake, the temperature of which will then decrease.

Process B: Let the flywheel be brought to rest by using its K.E. in raising weights, with no change in temperature.

Process C: Now let heat be supplied from a source to the flywheel and the brake, to restore the system to its initial state.

Therefore, the processes *A*, *B*, and *C* together constitute a cycle producing work by exchanging heat with a single reservoir. This violates the Kelvin-Planck statement, and it will become a PMM2. So the braking process, i.e., the transformation of K.E. into molecular internal energy, is irreversible.

(b) Paddle-Wheel Work Transfer

Work may be transferred into a system in an insulated container by means of a paddle wheel (Fig. 6.17) which is also known as stirring work. Here work transferred is dissipated adiabatically into an increase in the molecular internal energy of the system. To prove the irreversibility of the process, let us assume that the same amount of work is delivered by the system at the expense of its molecular internal energy, and the temperature of the system goes down (Fig. 6.18). The system is brought back to its initial state by heat transfer from a source. These two processes together constitute a cycle in which there is work output and the system exchanges heat with a single reservoir. It becomes a PMM2, and hence the dissipation of stirring work to internal energy is irreversible.

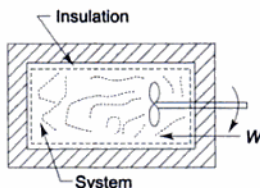

Fig. 6.17 Adiabatic work transfer

assume that the same amount of work is delivered by the system at the expense of its molecular internal energy, and the temperature of the system goes down (Fig. 6.18). The system is brought back to its initial state by heat transfer from a source. These two processes together constitute a cycle in which there is work output and the system exchanges heat with a single reservoir. It becomes a PMM2, and hence the dissipation of stirring work to internal energy is irreversible.

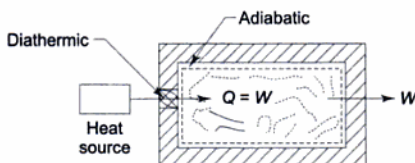

Fig. 6.18 Irreversibility due to dissipation of stirring work into internal energy

(c) Transfer of Electricity through a Resistor The flow of electric current through a wire represents work transfer, because the current can drive a motor which can raise a weight. Taking the wire or the resistor as the system (Fig. 6.19) and writing the first law

$$Q_{1-2} = U_2 - U_1 + W_{1-2}$$

Here both W_{1-2} and Q_{1-2} are negative.

$$\therefore W_{1-2} = U_2 - U_1 + Q_{1-2} \tag{6.12}$$

A part of the work transfer is stored as an increase in the internal energy of the wire (to give an increase in its temperature), and the remainder leaves the system as heat. At steady state, the internal energy and hence the temperature of the resistor become constant with respect to time and

$$W_{1-2} = Q_{1-2} \tag{6.13}$$

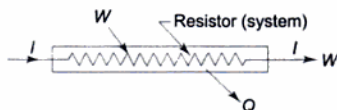

Fig. 6.19 Irreversibility due to dissipation of electrical work into internal energy

The reverse process, i.e., the conversion of heat Q_{1-2} into electrical work W_{1-2} of the same magnitude is not possible. Let us assume that this is possible. Then heat Q_{1-2} will be absorbed and equal work W_{1-2} will be delivered. But this will become a PMM2. So the dissipation of electrical work into internal energy or heat is irreversible.

6.10 Conditions for Reversibility

A natural process is irreversible because the conditions for mechanical, thermal and chemical equilibrium are not satisfied, and the dissipative effects, in which work is transformed into an increase in internal energy, are present. For a process to be reversible, it must not possess these features. If a process is performed quasi-statically, the system passes through states of thermodynamic equilibrium, which may be traversed as well in one direction as in the opposite direction. *If there are no dissipative effects, all the work done by the system during the performance of a process in one direction can be returned to the system during the reverse process.*

A process will be reversible when it is performed in such a way *that the system is at all times infinitesimally near a state of thermodynamic equilibrium and in the absence of dissipative effect of any form.* Reversible processes are, therefore, purely ideal, limiting cases of actual processes.

6.11 Carnot Cycle

A reversible cycle is an ideal hypothetical cycle in which all the processes constituting the cycle are reversible. Carnot cycle is a reversible cycle. For a stationary system, as in a piston and cylinder machine, the cycle consists of the following four successive processes (Fig. 6.20):

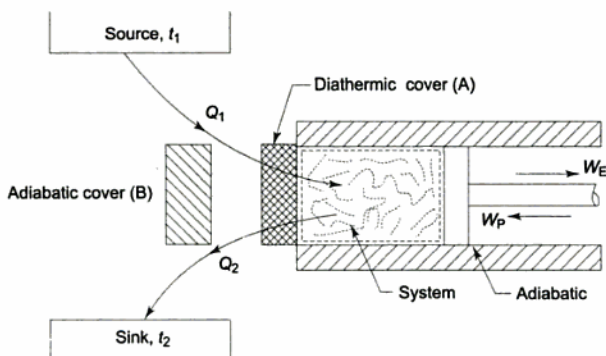

Fig. 6.20 Carnot heat engine-stationary system

(a) *A reversible isothermal process* in which heat Q_1 enters the system at t_1 reversibly from a constant temperature source at t_1 when the cylinder cover is in contact with the diathermic cover A . The internal energy of the system increases.

From First law,

$$Q_1 = U_2 - U_1 + W_{1-2} \quad (6.14)$$

(for an ideal gas only, $U_1 = U_2$)

(b) *A reversible adiabatic process* in which the diathermic cover A is replaced by the adiabatic cover B , and work W_E is done by the system adiabatically and reversibly at the expense of its internal energy, and the temperature of the system decreases from t_1 to t_2 .

Using the first law,

$$0 = U_3 - U_2 + W_{2-3} \quad (6.15)$$

(c) *A reversible isothermal process* in which B is replaced by A and heat Q_2 leaves the system at t_2 to a constant temperature sink at t_2 reversibly, and the internal energy of the system further decreases.

From the first law,

$$-Q_2 = U_4 - U_3 - W_{3-4} \quad (6.16)$$

only for an ideal gas, $U_3 = U_4$

(d) *A reversible adiabatic process* in which B again replaces A , and work W_p is done upon the system reversibly and adiabatically, and the internal energy of the system increases and the temperature rises from t_2 to t_1 .

Applying the first law,

$$0 = U_1 - U_4 - W_{4-1} \quad (6.17)$$

Two reversible isotherms and two reversible adiabatics constitute a Carnot cycle, which is represented in p - v coordinates in Fig. 6.21.

Summing up Eqs (6.14) to (6.17),

$$Q_1 - Q_2 = (W_{1-2} + W_{2-3}) - (W_{3-4} + W_{4-1})$$

or

$$\sum_{\text{cycle}} Q_{\text{net}} = \sum_{\text{cycle}} W_{\text{net}}$$

A cyclic heat engine operating on the Carnot cycle is called a Carnot heat engine.

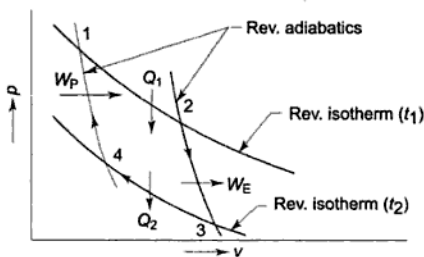

Fig. 6.21 Carnot cycle

For a steady flow system, the Carnot cycle is represented as shown in Fig. 6.22. Here heat Q_1 is transferred to the system reversibly and isothermally at t_1 in the heat exchanger A , work W_T is done by the system reversibly and adiabatically in the turbine (B), then heat Q_2 is transferred from the system reversibly and isothermally at t_2 in the heat exchanger (C), and then work W_p is done upon the system reversibly and adiabatically by the pump (D). To satisfy the conditions for the Carnot cycle, there must not be any friction or heat transfer in the pipelines through which the working fluid flows.

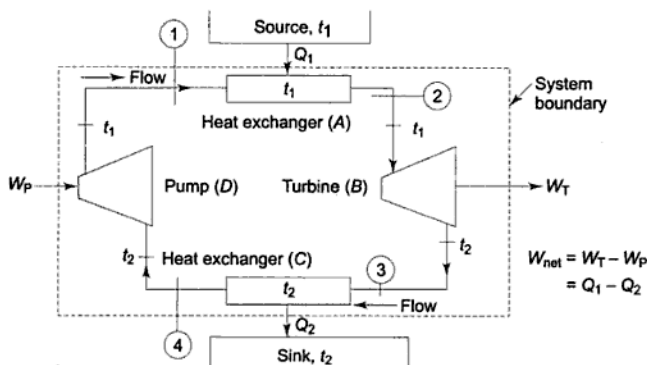

Fig. 6.22 Carnot heat engine—steady flow system

6.12 Reversed Heat Engine

Since all the processes of the Carnot cycle are reversible, it is possible to imagine that the processes are individually reversed and carried out in reverse order. When a reversible process is reversed, all the energy transfers associated with the process are reversed in direction, but remain the same in magnitude. The reversed Carnot cycle for a steady flow system is shown in Fig. 6.23. The reversible heat engine and the reversed Carnot heat engine are represented in block diagrams in Fig. 6.24. If E is a reversible heat engine (Fig. 6.24a), and if it is reversed (Fig. 6.24b), the quantities Q_1 , Q_2 and W remain the same in magnitude, and only their directions are reversed. The reversed heat engine \exists takes heat from a low temperature body, discharges heat to a high temperature body, and receives an inward flow of network.

The names *heat pump* and *refrigerator* are applied to the reversed heat engine, which have already been discussed in Sec. 6.6, where the working fluid flows through the compressor (B), condenser (A), expander (D), and evaporator (C) to complete the cycle.

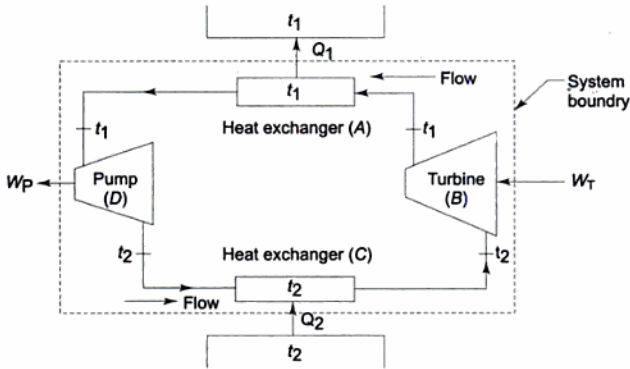

Fig. 6.23 Reversed Carnot heat engine-steady flow process

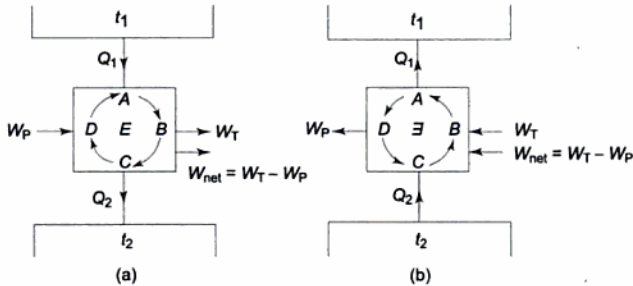

Fig. 6.24 Carnot heat engine and reversed Carnot heat engine shown in block diagrams

6.13 Carnot's Theorem

It states that of all heat engines operating between a given constant temperature source and a given constant temperature sink, none has a higher efficiency than a reversible engine.

Let two heat engines E_A and E_B operate between the given source at temperature t_1 and the given sink at temperature t_2 as shown in Fig. 6.25.

Let E_A be any heat engine and E_B be any reversible heat engine. We have to prove that the efficiency of E_B is more than that of E_A . Let us assume that this is not true and $\eta_A > \eta_B$. Let the rates of working of the engines be such that

$$Q_{1A} = Q_{1B} = Q_1$$

Since $\eta_A > \eta_B$

$$\frac{W_A}{Q_{1A}} > \frac{W_B}{Q_{1B}}$$

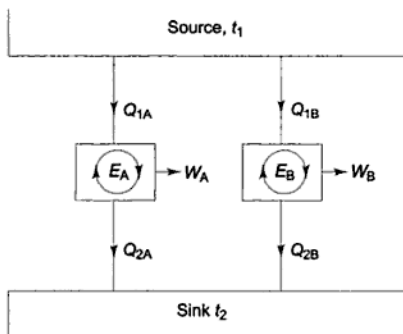

Fig. 6.25 Two cyclic heat engines E_A and E_B operating between the same source and sink, of which E_B is reversible

$$\therefore W_A > W_B$$

Now, let E_B be reversed. Since E_B is a reversible heat engine, the magnitudes of heat and work transfer quantities will remain the same, but their directions will be reversed, as shown in Fig. 6.26. Since $W_A > W_B$, some part of W_A (equal to W_B) may be fed to drive the reversed heat engine Ξ_B .

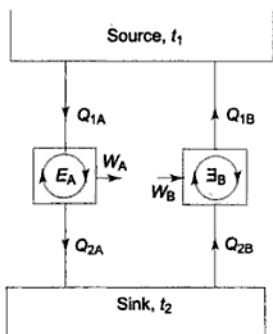

Fig. 6.26 E_B is reversed

Since $Q_{1A} = Q_{1B} = Q_1$, the heat discharged by Ξ_B may be supplied to E_A . The source may, therefore, be eliminated (Fig. 6.27). The net result is that E_A and Ξ_B together constitute a heat engine which, operating in a cycle, produces net work $W_A - W_B$, while exchanging heat with a single reservoir at t_2 . This violates the Kelvin-Planck statement of the second law. Hence the assumption that $\eta_A > \eta_B$ is wrong.

Therefore $\eta_B \geq \eta_A$

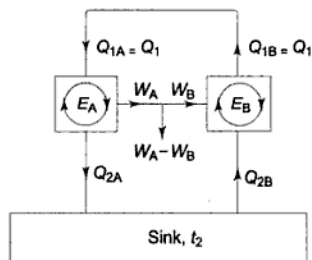

Fig. 6.27 E_A and E_B together violate the K-P statement

6.14 Corollary of Carnot's Theorem

The efficiency of all reversible heat engines operating between the same temperature levels is the same.

Let both the heat engines E_A and E_B (Fig. 6.25) be reversible. Let us assume $\eta_A > \eta_B$. Similar to the procedure outlined in the preceding article, if E_B is reversed to run, say, as a heat pump using some part of the work output (W_A) of engine E_A , we see that the combined system of heat pump E_B and engine E_A , becomes a PMM2. So η_A cannot be greater than η_B . Similarly, if we assume $\eta_B > \eta_A$ and reverse the engine E_A , we observe that η_B cannot be greater than η_A . Therefore

$$\eta_A = \eta_B$$

Since the efficiencies of all reversible heat engines operating between the same heat reservoirs are the same, *the efficiency of a reversible engine is independent of the nature or amount of the working substance undergoing the cycle.*

6.15 Absolute Thermodynamic Temperature Scale

The efficiency of any heat engine cycle receiving heat Q_1 and rejecting heat Q_2 is given by

$$\eta = \frac{W_{\text{net}}}{Q_1} = \frac{Q_1 - Q_2}{Q_1} = 1 - \frac{Q_2}{Q_1} \quad (6.18)$$

By the second law, it is necessary to have a temperature difference ($t_1 - t_2$) to obtain work of any cycle. We know that the efficiency of all heat engines operating between the same temperature levels is the same, and it is independent of the working substance. Therefore, for a reversible cycle (Carnot cycle), the efficiency will depend solely upon the temperatures t_1 and t_2 , at which heat is transferred, or

$$\eta_{\text{rev}} = f(t_1, t_2) \quad (6.19)$$

where f signifies some function of the temperatures. From Eqs (6.18) and (6.19)

$$1 - \frac{Q_2}{Q_1} = f(t_1, t_2)$$

In terms of a new function F

$$\frac{Q_1}{Q_2} = F(t_1, t_2) \quad (6.20)$$

If some functional relationship is assigned between t_1 , t_2 and Q_1/Q_2 , the equation becomes the definition of a temperature scale.

Let us consider two reversible heat engines, E_1 receiving heat from the source at t_1 , and rejecting heat at t_2 to E_2 which, in turn, rejects heat to the sink at t_3 (Fig. 6.28).

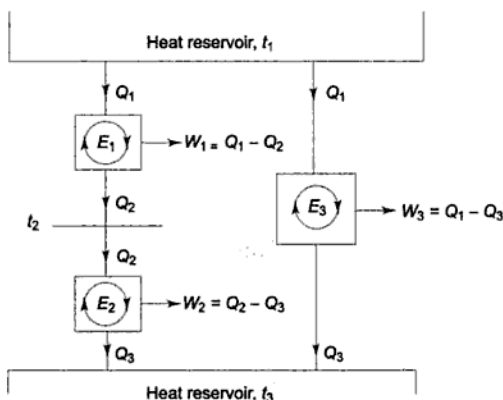

Fig. 6.28 Three Carnot engines

Now
$$\frac{Q_1}{Q_2} = F(t_1, t_2); \quad \frac{Q_2}{Q_3} = F(t_2, t_3)$$

E_1 and E_2 together constitute another heat engine E_3 operating between t_1 and t_3 .

\therefore
$$\frac{Q_1}{Q_3} = F(t_1, t_3)$$

Now
$$\frac{Q_1}{Q_2} = \frac{Q_1/Q_3}{Q_2/Q_3}$$

or
$$\frac{Q_1}{Q_2} = F(t_1, t_2) = \frac{F(t_1, t_3)}{F(t_2, t_3)} \quad (6.21)$$

The temperatures t_1 , t_2 and t_3 are arbitrarily chosen. The ratio Q_1/Q_2 depends only on t_1 and t_2 , and is independent of t_3 . So t_3 will drop out from the ratio on the right in equation (6.21). After it has been cancelled, the numerator can be written as $\phi(t_1)$, and the denominator as $\phi(t_2)$, where ϕ is another unknown function. Thus

$$\frac{Q_1}{Q_2} = F(t_1, t_2) = \frac{\phi(t_1)}{\phi(t_2)}$$

Since $\phi(t)$ is an arbitrary function, the simplest possible way to define the absolute thermodynamic temperature T is to let $\phi(t) = T$, as proposed by Kelvin. Then, by definition

$$\frac{Q_1}{Q_2} = \frac{T_1}{T_2} \quad (6.22)$$

The absolute thermodynamic temperature scale is also known as the *Kelvin scale*. Two temperatures on the Kelvin scale bear the same relationship to each other as do the heats absorbed and rejected respectively by a Carnot engine operating between two reservoirs at these temperatures. The Kelvin temperature scale is, therefore, independent of the peculiar characteristics of any particular substance.

The heat absorbed Q_1 and the heat rejected Q_2 during the two reversible isothermal processes bounded by two reversible adiabatics in a Carnot engine can be measured. In defining the Kelvin temperature scale also, the triple point of water is taken as the standard reference point. For a Carnot engine operating between reservoirs at temperatures T and T_1 , T_1 being the triple point of water (Fig. 6.29), arbitrarily assigned the value 273.16 K,

$$\frac{Q}{Q_1} = \frac{T}{T_1}$$

$$\therefore T = 273.16 \frac{Q}{Q_1} \quad (6.23)$$

If this equation is compared with the equations given in Article 2.3, it is seen that *in the Kelvin scale, Q plays the role of thermometric property*. The amount of heat supply Q changes with change in temperature, just like the thermal emf in a thermocouple.

It follows from the Eq. (6.23),

$$T = 273.16 \frac{Q}{Q_1}$$

that the heat transferred isothermally between the given adiabatics decreases as the temperature decreases. Conversely, the smaller the value of Q , the lower the corresponding T . The smallest possible value of Q is zero, and the corresponding T is absolute zero. Thus, if a system undergoes a reversible isothermal process without transfer of heat, the temperature at which this process takes place is called the *absolute zero*. Thus, *at absolute zero, an isotherm and an adiabatic are identical*.

That the absolute thermodynamic temperature scale has a definite zero point can be shown by imagining a series of reversible engines, extending from a source at T_1 to lower temperatures (Fig. 6.30).

Since

$$\frac{T_1}{T_2} = \frac{Q_1}{Q_2}$$

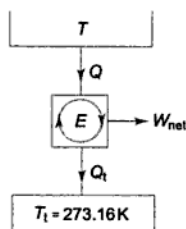

Fig. 6.29 Carnot heat engine with sink at triple point of water

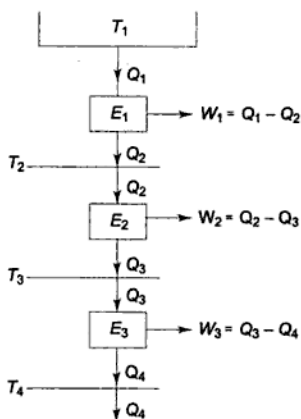

Fig. 6.30 Heat engines operating in series

$$\therefore \frac{T_1 - T_2}{T_2} = \frac{Q_1 - Q_2}{Q_2}$$

$$\text{or} \quad T_1 - T_2 = (Q_1 - Q_2) \frac{T_2}{Q_2}$$

Similarly

$$T_2 - T_3 = (Q_2 - Q_3) \frac{T_3}{Q_3}$$

$$= (Q_2 - Q_3) \frac{T_2}{Q_2}$$

$$T_3 - T_4 = (Q_3 - Q_4) \frac{T_2}{Q_2}$$

and so on.

If $T_1 - T_2 = T_2 - T_3 = T_3 - T_4 = \dots$, assuming equal temperature intervals

$$Q_1 - Q_2 = Q_2 - Q_3 = Q_3 - Q_4 = \dots$$

$$\text{or} \quad W_1 = W_2 = W_3 = \dots$$

Conversely, by making the work quantities performed by the engines in series equal ($W_1 = W_2 = W_3 = \dots$), we will get

$$T_1 - T_2 = T_2 - T_3 = T_3 - T_4 = \dots$$

at equal temperature intervals. A scale having one hundred equal intervals between the steam point and the ice point could be realized by a series of one hundred Carnot engines operating as in Fig. 6.30. Such a scale would be independent of the working substance.

If enough engines are placed in series to make the total work output equal to Q_1 , then by the first law the heat rejected from the last engine will be zero. By the second law, however, the operation of a cyclic heat engine with zero heat rejection cannot be achieved, although it may be approached as a limit. When the heat rejected approaches zero, the temperature of heat rejection also approaches zero as a limit. *Thus it appears that a definite zero point exists on the absolute temperature scale but this point cannot be reached without a violation of the second law.*

Thus any attainable value of absolute temperature is always greater than zero. This is also known as the *Third Law of Thermodynamics* which may be stated as follows: *It is impossible by any procedure, no matter how idealized, to reduce any system to the absolute zero of temperature in a finite number of operations.*

This is what is called the Fowler-Guggenheim statement of the third law. The third law itself is an independent law of nature, and not an extension of the second law. The concept of heat engine is not necessary to prove the non-attainability of absolute zero of temperature by any system in a finite number of operations.

6.16 Efficiency of the Reversible Heat Engine

The efficiency of a reversible heat engine in which heat is received solely at T_1 is found to be

$$\eta_{\text{rev}} = \eta_{\text{max}} = 1 - \left(\frac{Q_2}{Q_1} \right)_{\text{rev}} = 1 - \frac{T_2}{T_1}$$

or

$$\eta_{\text{rev}} = \frac{T_1 - T_2}{T_1}$$

It is observed here that as T_2 decreases, and T_1 increases, the efficiency of the reversible cycle increases.

Since η is always less than unity, T_2 is always greater than zero and positive. The COP of a refrigerator is given by

$$(\text{COP})_{\text{refr}} = \frac{Q_2}{Q_1 - Q_2} = \frac{1}{\frac{Q_1}{Q_2} - 1}$$

For a reversible refrigerator, using

$$\frac{Q_1}{Q_2} = \frac{T_1}{T_2}$$

$$[\text{COP}_{\text{refr}}]_{\text{rev}} = \frac{T_2}{T_1 - T_2} \quad (6.24)$$

Similarly, for a reversible heat pump

$$[\text{COP}_{\text{H.P.}}]_{\text{rev}} = \frac{T_1}{T_1 - T_2} \quad (6.25)$$

6.17 Equality of Ideal Gas Temperature and Kelvin Temperature

Let us consider a Carnot cycle executed by an ideal gas, as shown in Fig. 6.31.

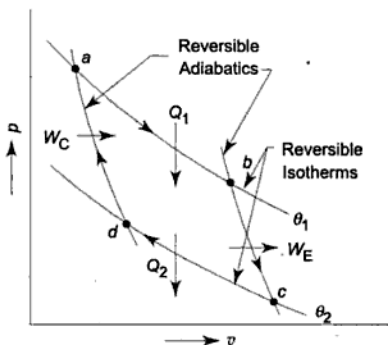

Fig. 6.31 Carnot cycle of an ideal gas

The two isothermal processes $a-b$ and $c-d$ are represented by equilateral hyperbolas whose equations are respectively

$$pV = nR \theta_1$$

and

$$pV = nR \theta_2$$

For any infinitesimal reversible process of an ideal gas, the first law may be written as

$$dQ = C_v d\theta + p dV$$

Applying this equation to the isothermal process $a-b$, the heat absorbed is found to be

$$Q_1 = \int_{V_a}^{V_b} p dV = \int_{V_a}^{V_b} \frac{nR\theta_1}{V} dV = nR\theta_1 \ln \frac{V_b}{V_a}$$

Similarly, for the isothermal process $c-d$, the heat rejected is

$$Q_2 = nR\theta_2 \ln \frac{V_c}{V_d}$$

\therefore

$$\frac{Q_1}{Q_2} = \frac{\theta_1 \ln \frac{V_b}{V_a}}{\theta_2 \ln \frac{V_c}{V_d}} \quad (6.26)$$

Since the process $b-c$ is adiabatic, the first law gives

$$-C_v d\theta = p dV = \frac{nR\theta}{V} dV$$

$$\frac{1}{nR} \int_{\theta_2}^{\theta_1} C_v \frac{d\theta}{\theta} = \ln \frac{V_c}{V_b}$$

Similarly, for the adiabatic process $d-a$

$$\frac{1}{nR} \int_{\theta_2}^{\theta_1} C_v \frac{d\theta}{\theta} = \ln \frac{V_d}{V_a}$$

$$\therefore \ln \frac{V_c}{V_b} = \ln \frac{V_d}{V_a}$$

$$\text{or} \quad \frac{V_c}{V_b} = \frac{V_d}{V_a}$$

$$\text{or} \quad \frac{V_b}{V_a} = \frac{V_c}{V_d} \quad (6.27)$$

Equation (6.26) thus reduces to

$$\frac{Q_1}{Q_2} = \frac{\theta_1}{\theta_2} \quad (6.28)$$

Kelvin temperature was defined by Eq. (6.22)

$$\frac{Q_1}{Q_2} = \frac{T_1}{T_2}$$

If θ and T refer to any temperature, and θ_t and T_t refer to the triple point of water,

$$\frac{\theta}{\theta_t} = \frac{T}{T_t}$$

Since $\theta_t = T_t = 273.16$ K, it follows that

$$\theta = T \quad (6.29)$$

The Kelvin temperature is, therefore, numerically equal to the ideal gas temperature and may be measured by means of a gas thermometer.

6.18 Types of Irreversibility

It has been discussed in Sec. 6.9 that a process becomes irreversible if it occurs due to a finite potential gradient like the gradient in temperature or pressure, or if there is dissipative effect like friction, in which work is transformed into internal energy increase of the system. Two types of irreversibility can be distinguished:

- (a) Internal irreversibility
- (b) External irreversibility

The *internal irreversibility* is caused by the internal dissipative effects like friction, turbulence, electrical resistance, magnetic hysteresis, etc. within the system. The *external irreversibility* refers to the irreversibility occurring at the system boundary like heat interaction with the surroundings due to a finite temperature gradient.

Sometimes, it is useful to make other distinctions. If the irreversibility of a process is due to the dissipation of work into the increase in internal energy of a system, or due to a finite pressure gradient, it is called *mechanical irreversibility*. If the process occurs on account of a finite temperature gradient, it is *thermal irreversibility*, and if it is due to a finite concentration gradient or a chemical reaction, it is called *chemical irreversibility*.

A heat engine cycle in which there is a temperature difference (i) between the source and the working fluid during heat supply, and (ii) between the working fluid and the sink during heat rejection, exhibits external thermal irreversibility. If the real source and sink are not considered and hypothetical reversible processes for heat supply and heat rejection are assumed, the cycle can be reversible. With the inclusion of the actual source and sink, however, the cycle becomes externally irreversible.

SOLVED EXAMPLES

Example 6.1 A cyclic heat engine operates between a source temperature of 800°C and a sink temperature of 30°C . What is the least rate of heat rejection per kW net output of the engine?

Solution For a reversible engine, the rate of heat rejection will be minimum (Fig. Ex. 6.1).

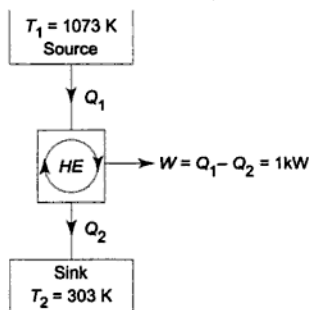

Fig. Ex. 6.1

$$\eta_{\max} = \eta_{\text{rev}} = 1 - \frac{T_2}{T_1}$$

$$= 1 - \frac{30 + 273}{800 + 273}$$

$$= 1 - 0.282 = 0.718$$

Now $\frac{W_{\text{net}}}{Q_1} = \eta_{\text{max}} = 0.718$

$\therefore Q_1 = \frac{1}{0.718} = 1.392 \text{ kW}$

Now $Q_2 = Q_1 - W_{\text{net}} = 1.392 - 1$
 $= 0.392 \text{ kW}$

This is the least rate of heat rejection.

Example 6.2 A domestic food freezer maintains a temperature of -15°C . The ambient air temperature is 30°C . If heat leaks into the freezer at the continuous rate of 1.75 kJ/s what is the least power necessary to pump this heat out continuously?

Solution Freezer temperature,

$$T_2 = -15 + 273 = 258 \text{ K}$$

Ambient air temperature,

$$T_1 = 30 + 273 = 303 \text{ K}$$

The refrigerator cycle removes heat from the freezer at the same rate at which heat leaks into it (Fig. Ex. 6.2).

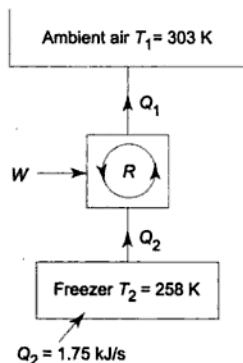

Fig. Ex. 6.2

For minimum power requirement

$$\frac{Q_2}{T_2} = \frac{Q_1}{T_1}$$

$$\begin{aligned} \therefore Q_1 &= \frac{1.75}{258} \times 303 = 2.06 \text{ kJ/s} \\ \therefore W &= Q_1 - Q_2 \\ &= 2.06 - 1.75 = 0.31 \text{ kJ/s} \\ &= 0.31 \text{ kW} \end{aligned}$$

Example 6.3 A reversible heat engine operates between two reservoirs at temperatures of 600°C and 40°C . The engine drives a reversible refrigerator which operates between reservoirs at temperatures of 40°C and -20°C . The heat transfer to the heat engine is 2000 kJ and the net work output of the combined engine refrigerator plant is 360 kJ .

- (a) Evaluate the heat transfer to the refrigerant and the net heat transfer to the reservoir at 40°C .
 (b) Reconsider (a) given that the efficiency of the heat engine and the COP of the refrigerator are each 40% of their maximum possible values.

Solution (a) Maximum efficiency of the heat engine cycle (Fig. Ex. 6.3) is given by

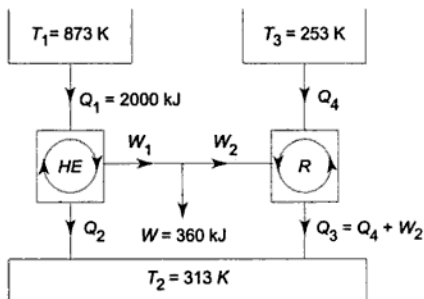

Fig. Ex. 6.3

$$\eta_{\max} = 1 - \frac{T_2}{T_1} = 1 - \frac{313}{873} = 1 - 0.358 = 0.642$$

Again
$$\frac{W_1}{Q_1} = 0.642$$

$$\therefore W_1 = 0.642 \times 2000 = 1284 \text{ kJ}$$

Maximum COP of the refrigerator cycle

$$(\text{COP})_{\max} = \frac{T_3}{T_2 - T_3} = \frac{253}{313 - 253} = 4.22$$

Also
$$\text{COP} = \frac{Q_4}{W_2} = 4.22$$

Since
$$W_1 - W_2 = W = 360 \text{ kJ}$$

$$\begin{aligned} \therefore W_2 &= W_1 - W = 1284 - 360 = 924 \text{ kJ} \\ \therefore Q_4 &= 4.22 \times 924 = 3899 \text{ kJ} \\ \therefore Q_3 &= Q_4 + W_2 = 924 + 3899 = 4823 \text{ kJ} \\ Q_2 &= Q_1 - W_1 = 2000 - 1284 = 716 \text{ kJ} \end{aligned}$$

Heat rejection to the 40°C reservoir

$$= Q_2 + Q_3 = 716 + 4823 = 5539 \text{ kJ} \quad \text{Ans. (a)}$$

(b) Efficiency of the actual heat engine cycle

$$\eta = 0.4 \eta_{\max} = 0.4 \times 0.642$$

$$\begin{aligned} \therefore W_1 &= 0.4 \times 0.642 \times 2000 \\ &= 513.6 \text{ kJ} \end{aligned}$$

$$\therefore W_2 = 513.6 - 360 = 153.6 \text{ kJ}$$

COP of the actual refrigerator cycle

$$\text{COP} = \frac{Q_4}{W_2} = 0.4 \times 4.22 = 1.69$$

Therefore

$$Q_4 = 153.6 \times 1.69 = 259.6 \text{ kJ} \quad \text{Ans. (b)}$$

$$Q_3 = 259.6 + 153.6 = 413.2 \text{ kJ}$$

$$Q_2 = Q_1 - W_1 = 2000 - 513.6 = 1486.4 \text{ kJ}$$

Heat rejected to the 40°C reservoir

$$= Q_2 + Q_3 = 413.2 + 1486.4 = 1899.6 \text{ kJ} \quad \text{Ans. (b)}$$

Example 6.4 Which is the more effective way to increase the efficiency of a Carnot engine: to increase T_1 , keeping T_2 constant; or to decrease T_2 , keeping T_1 constant?

Solution The efficiency of a Carnot engine is given by

$$\eta = 1 - \frac{T_2}{T_1}$$

If T_2 is constant

$$\left(\frac{\partial \eta}{\partial T_1} \right)_{T_2} = \frac{T_2}{T_1^2}$$

As T_1 increases, η increases, and the slope $\left(\frac{\partial \eta}{\partial T_1} \right)_{T_2}$ decreases (Fig. Ex. 6.4.1).

If T_1 is constant,

$$\left(\frac{\partial \eta}{\partial T_2} \right)_{T_1} = -\frac{1}{T_1}$$

As T_2 decreases, η increases, but the slope $\left(\frac{\partial \eta}{\partial T_2} \right)_{T_1}$ remains constant (Fig. Ex. 6.4.2).

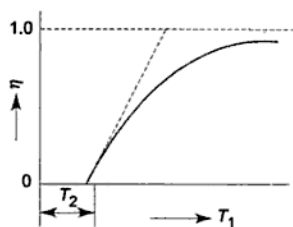

Fig. Ex. 6.4.1

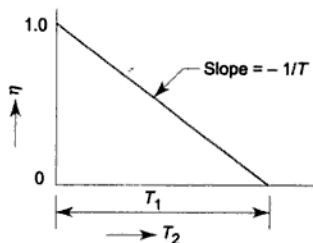

Fig. Ex. 6.4.2

Also
$$\left(\frac{\partial \eta}{\partial T_1}\right)_{T_2} = \frac{T_2}{T_1^2} \text{ and } \left(\frac{\partial \eta}{\partial T_2}\right)_{T_1} = -\frac{T_1}{T_1^2}$$

Since $T_1 > T_2$,
$$\left(\frac{\partial \eta}{\partial T_2}\right)_{T_1} > \left(\frac{\partial \eta}{\partial T_1}\right)_{T_2}$$

So, the more effective way to increase the efficiency is to decrease T_2 . Alternatively, let T_2 be decreased by ΔT with T_1 remaining the same

$$\eta_1 = 1 - \frac{T_2 - \Delta T}{T_1}$$

If T_1 is increased by the same ΔT , T_2 remaining the same

$$\eta_2 = 1 - \frac{T_2}{T_1 + \Delta T}$$

Then

$$\begin{aligned} \eta_1 - \eta_2 &= \frac{T_2}{T_1 + \Delta T} - \frac{T_2 - \Delta T}{T_1} \\ &= \frac{(T_1 - T_2)\Delta T + (\Delta T)^2}{T_1(T_1 + \Delta T)} \end{aligned}$$

Since $T_1 > T_2$, $(\eta_1 - \eta_2) > 0$

The more effective way to increase the cycle efficiency is to decrease T_2 .

Example 6.5 Kelvin was the first to point out the thermodynamic wastefulness of burning fuel for the direct heating of a house. It is much more economical to use the high temperature heat produced by combustion in a heat engine and then to use the work so developed to pump heat from outdoors up to the temperature desired in the house. In Fig. Ex. 6.5 a boiler furnishes heat Q_1 at the high temperature T_1 . This heat is absorbed by a heat engine, which extracts work W and rejects the waste heat Q_2 into the house at T_2 . Work W is in turn used to operate a mechanical refrigerator or heat pump, which extracts Q_3 from outdoors at temperature T_3 and rejects Q'_2 (where $Q'_2 = Q_3 + W$) into the house. As a result

of this cycle of operations, a total quantity of heat equal to $Q_2 + Q'_2$ is liberated in the house, against Q_1 which would be provided directly by the ordinary combustion of the fuel. Thus the ratio $(Q_2 + Q'_2)/Q_1$ represents the heat multiplication factor of this method. Determine this multiplication factor if $T_1 = 473$ K, $T_2 = 293$ K, and $T_3 = 273$ K.

Solution For the reversible heat engine (Fig. Ex. 6.5)

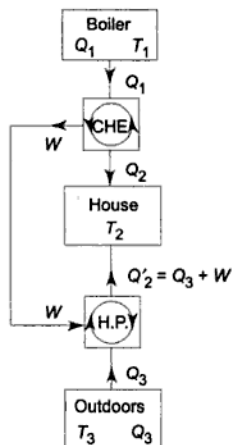

Fig. Ex. 6.5

$$\frac{Q_2}{Q_1} = \frac{T_2}{T_1}$$

$$\therefore Q_2 = Q_1 \left(\frac{T_2}{T_1} \right)$$

Also
$$\eta = \frac{W}{Q_1} = \frac{T_1 - T_2}{T_1}$$

or
$$W = \frac{T_1 - T_2}{T_1} \cdot Q_1$$

For the reversible heat pump

$$\text{COP} = \frac{Q'_2}{W} = \frac{T_2}{T_2 - T_3}$$

$$\therefore Q'_2 = \frac{T_2}{T_2 - T_3} \cdot \frac{T_1 - T_2}{T_1} \cdot Q_1$$

\therefore Multiplication factor (M.F.)

$$= \frac{Q_2 + Q_2'}{Q_1} = \frac{Q_1 \frac{T_2}{T_1} + Q_1 \cdot \frac{T_2}{T_2 - T_3} \cdot \frac{T_1 - T_2}{T_1}}{Q_1}$$

$$\text{or} \quad \text{M.F.} = \frac{T_2^2 - T_2 T_3 + T_2 T_1 - T_2^2}{T_1(T_2 - T_3)}$$

$$\text{or} \quad \text{M.F.} = \frac{T_2(T_1 - T_3)}{T_1(T_2 - T_3)}$$

Here $T_1 = 473 \text{ K}$, $T_2 = 293 \text{ K}$ and $T_3 = 273 \text{ K}$

$$\therefore \quad \text{M.F.} = \frac{293(473 - 273)}{473(293 - 273)} = \frac{2930}{473} = 6.3 \quad \text{Ans.}$$

which means that every kg of coal burned would deliver the heat equivalent to over 6 kg. Of course, in an actual case, the efficiencies would be less than Carnot efficiencies, but even with a reduction of 50%, the possible savings would be quite significant.

Example 6.6 It is proposed that solar energy be used to warm a large collector plate. This energy would, in turn, be transferred as heat to a fluid within a heat engine, and the engine would reject energy as heat to the atmosphere. Experiments indicate that about $1880 \text{ kJ/m}^2 \text{ h}$ of energy can be collected when the plate is operating at 90°C . Estimate the minimum collector area that would be required for a plant producing 1 kW of useful shaft power. The atmospheric temperature may be assumed to be 20°C .

Solution The maximum efficiency for the heat engine operating between the collector plate temperature and the atmospheric temperature is

$$\eta_{\max} = 1 - \frac{T_2}{T_1} = 1 - \frac{293}{363} = 0.192$$

The efficiency of any actual heat engine operating between these temperatures would be less than this efficiency.

$$\therefore \quad Q_{\min} = \frac{W}{\eta_{\max}} = \frac{1 \text{ kJ/s}}{0.192} = 5.21 \text{ kJ/s}$$

$$= 18,800 \text{ kJ/h}$$

\therefore Minimum area required for the collector plate

$$= \frac{18,800}{1880} = 10 \text{ m}^2 \quad \text{Ans.}$$

Example 6.7 A reversible heat engine in a satellite operates between a hot reservoir at T_1 and a radiating panel at T_2 . Radiation from the panel is proportional to its area and to T_2^4 . For a given work output and value of T_1 show that the area of the panel will be minimum when $\frac{T_2}{T_1} = 0.75$.

Determine the minimum area of the panel for an output of 1 kW if the constant of proportionality is $5.67 \times 10^{-8} \text{ W/m}^2\text{K}^4$ and T_1 is 1000 K.

Solution For the heat engine (Fig. Ex. 6.7), the heat rejected Q_2 to the panel (at T_2) is equal to the energy emitted from the panel to the surroundings by radiation. If A is the area of the panel, $Q_2 \propto AT_2^4$, or $Q_2 = KAT_2^4$, where K is a constant.

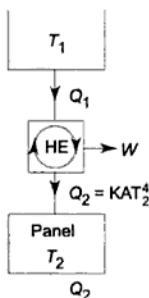

Fig. Ex. 6.7

Now
$$\eta = \frac{W}{Q_1} = \frac{T_1 - T_2}{T_1}$$

or
$$\frac{W}{T_1 - T_2} = \frac{Q_1}{T_1} = \frac{Q_2}{T_2} = \frac{KAT_2^4}{T_2} = KAT_2^3$$

$$\therefore A = \frac{W}{KT_2^3(T_1 - T_2)} = \frac{W}{K(T_1T_2^3 - T_2^4)}$$

For a given W and T_1 , A will be minimum when

$$\frac{dA}{dT_2} = -\frac{W}{K} (3T_1T_2^2 - 4T_2^3) \cdot (T_1T_2^3 - T_2^4)^{-2} = 0$$

Since $(T_1T_2^3 - T_2^4)^{-2} \neq 0$, $3T_1T_2^2 = 4T_2^3$

$$\therefore \frac{T_2}{T_1} = 0.75 \text{ Proved.}$$

$$\therefore A_{\min} = \frac{W}{K(0.75)^3 T_1^3 (T_1 - 0.75T_1)}$$

$$= \frac{W}{K \frac{27}{256} T_1^4} = \frac{256W}{27KT_1^4}$$

Here $W = 1 \text{ kW}$, $K = 5.67 \times 10^{-8} \text{ W/m}^2\text{K}^4$, and $T_1 = 1000 \text{ K}$

$$\therefore A_{\min} = \frac{256 \times 1 \text{ kW} \times \text{m}^2\text{K}^4}{27 \times 5.67 \times 10^{-8} \text{ W} \times (1000)^4 \text{ K}^4}$$

$$\begin{aligned}
 &= \frac{256 \times 10^3}{27 \times 5.67 \times 10^{-8} \times 10^{12}} \text{ m}^2 \\
 &= 0.1672 \text{ m}^2
 \end{aligned}$$

Ans.

REVIEW QUESTIONS

- 6.1 What is the qualitative difference between heat and work? Why are heat and work not completely interchangeable forms of energy?
- 6.2 What is a cyclic heat engine?
- 6.3 Explain a heat engine cycle performed by a closed system.
- 6.4 Explain a heat engine cycle performed by a steady flow system.
- 6.5 Define the thermal efficiency of a heat engine cycle. Can this be 100%?
- 6.6 Draw a block diagram showing the four energy interactions of a cyclic heat engine.
- 6.7 What is a thermal energy reservoir? Explain the terms 'source' and 'sink'.
- 6.8 What is a mechanical energy reservoir?
- 6.9 Why can all processes in a TER or an MER be assumed to be quasi-static?
- 6.10 Give the Kelvin-Planck statement of the second law.
- 6.11 To produce net work in a thermodynamic cycle, a heat engine has to exchange heat with two thermal reservoirs. Explain.
- 6.12 What is a PMM2? Why is it impossible?
- 6.13 Give the Clausius' statement of the second law.
- 6.14 Explain the operation of a cyclic refrigerator plant with a block diagram.
- 6.15 Define the COP of a refrigerator.
- 6.16 What is a heat pump? How does it differ from a refrigerator?
- 6.17 Can you use the same plant as a heat pump in winter and as a refrigerator in summer? Explain.
- 6.18 Show that the COP of a heat pump is greater than the COP of a refrigerator by unity.
- 6.19 Why is direct heating thermodynamically wasteful?
- 6.20 How can a heat pump upgrade low grade waste heat?
- 6.21 Establish the equivalence of Kelvin-Planck and Clausius statements.
- 6.22 What is a reversible process? A reversible process should not leave any evidence to show that the process had ever occurred. Explain.
- 6.23 How is a reversible process only a limiting process, never to be attained in practice?
- 6.24 All spontaneous processes are irreversible. Explain.
- 6.25 What are the causes of irreversibility of a process?
- 6.26 Show that heat transfer through a finite temperature difference is irreversible.
- 6.27 Demonstrate, using the second law, that free expansion is irreversible.
- 6.28 What do you understand by dissipative effects? When is work said to be dissipated?
- 6.29 Explain perpetual motion of the third kind.
- 6.30 Demonstrate using the second law how friction makes a process irreversible.
- 6.31 When a rotating wheel is brought to rest by applying a brake, show that the molecular internal energy of the system (of the brake and the wheel) increases.

- 6.32 Show that the dissipation of stirring work to internal energy is irreversible.
- 6.33 Show by second law that the dissipation of electrical work into internal energy or heat is irreversible.
- 6.34 What is a Carnot cycle? What are the four processes which constitute the cycle?
- 6.35 Explain the Carnot heat engine cycle executed by: (a) a stationary system, and (b) a steady flow system.
- 6.36 What is a reversed heat engine?
- 6.37 Show that the efficiency of a reversible engine operating between two given constant temperatures is the maximum.
- 6.38 Show that the efficiency of all reversible heat engines operating between the same temperature levels is the same.
- 6.39 Show that the efficiency of a reversible engine is independent of the nature or amount of the working substance going through the cycle.
- 6.40 How does the efficiency of a reversible cycle depend only on the two temperatures at which heat is transferred?
- 6.41 What is the absolute thermodynamic temperature scale? Why is it called absolute?
- 6.42 How is the absolute scale independent of the working substance?
- 6.43 How does Q play the role of thermometric property in the Kelvin Scale?
- 6.44 Show that a definite zero point exists on the absolute temperature scale but that this point cannot be reached without a violation of the second law.
- 6.45 Give the Fowler-Guggenheim statement of the third law.
- 6.46 Is the third law an extension of the second law? Is it an independent law of nature? Explain.
- 6.47 How does the efficiency of a reversible engine vary as the source and sink temperatures are varied? When does the efficiency become 100%?
- 6.48 For a given T_2 , show that the COP of a refrigerator increases as T_1 decreases.
- 6.49 Explain how the Kelvin temperature can be measured with a gas thermometer.
- 6.50 Establish the equality of ideal gas temperature and Kelvin temperature.
- 6.51 What do you understand by internal irreversibility and external irreversibility?
- 6.52 Explain mechanical, thermal and chemical irreversibilities.
- 6.53 A Carnot engine with a fuel burning device as source and a heat sink cannot be treated as a reversible plant. Explain.

PROBLEMS

- 6.1 An inventor claims to have developed an engine that takes in 105 MKJ at a temperature of 400 K, rejects 42 MJ at a temperature of 200 K, and delivers 15 kWh of mechanical work. Would you advise investing money to put this engine in the market?
- 6.2 If a refrigerator is used for heating purposes in winter so that the atmosphere becomes the cold body and the room to be heated becomes the hot body, how much heat would be available for heating for each kW input to the driving motor? The COP of the refrigerator is 5, and the electromechanical efficiency of the motor is 90%. How does this compare with resistance heating?

Ans. 5.4 kW, 1kW

- 6.3 Using an engine of 30% thermal efficiency of drive a refrigerator having a COP of 5, what is the heat input into the engine for each MJ removed from the cold body by the refrigerator?

Ans. 666.67 kJ

If this system is used as a heat pump, how many MJ of heat would be available for heating for each MJ of heat input to the engine?

Ans. 1.8 MJ

- 6.4 An electric storage battery which can exchange heat only with a constant temperature atmosphere goes through a complete cycle of two processes. In process 1–2, 2.8 kWh of electrical work flow into the battery while 732 kJ of heat flow out to the atmosphere. During process 2–1, 2.4 kWh of work flow out of the battery. (a) Find the heat transfer in process 2–1. (b) If the process 1–2 has occurred as above, does the first law or the second law limit the maximum possible work of process 2–1? What is the maximum possible work? (c) If the maximum possible work were obtained in process 2–1, what will be the heat transfer in the process?

(a) – 708 kJ (b) Second law, $W_{2-1} = 9348$ kJ (c) $Q_{2-1} = 0$

- 6.5 A household refrigerator is maintained at a temperature of 2°C. Every time the door is opened, warm material is placed inside, introducing an average of 420 kJ, but making only a small change in the temperature of the refrigerator. The door is opened 20 times a day, and the refrigerator operates at 15% of the ideal COP. The cost of work is 32 paise per kWh. What is the monthly bill for this refrigerator? The atmosphere is at 30°C.

Ans. Rs. 15.20

- 6.6 A heat pump working on the Carnot cycle takes in heat from a reservoir at 5°C and delivers heat to a reservoir at 60°C. The heat pump is driven by a reversible heat engine which takes in heat from a reservoir at 840°C and rejects heat to a reservoir at 60°C. The reversible heat engine also drives a machine that absorbs 30 kW. If the heat pump extracts 17 kJ/s from the 5°C reservoir, determine (a) the rate of heat supply from the 840°C source, and (b) the rate of heat rejection to the 60°C sink.

Ans. (a) 47.61 kW; (b) 34.61 kW

- 6.7 A refrigeration plant for a food store operates with a COP which is 40% of the ideal COP of a Carnot of refrigerator. The store is to be maintained at a temperature of –5°C and the heat transfer from the store to the cycle is at the rate of 5 kW. If heat is transferred from the cycle to the atmosphere at a temperature of 25°C, calculate the power required to drive the plant and the heat discharged to the atmosphere.

Ans. 4.4 kW, 6.4 kW

- 6.8 A heat engine is used to drive a heat pump. The heat transfers from the heat engine and from the heat pump are used to heat the water circulating through the radiators of a building. The efficiency of the heat engine is 27% and the COP of the heat pump is 4. Evaluate the ratio of the heat transfer to the circulating water to the heat transfer to the heat engine.

Ans. 1.81

- 6.9 If 20 kJ are added to a Carnot cycle at a temperature of 100°C and 14.6 kJ are rejected at 0°C, determine the location of absolute zero on the Celsius scale.

Ans. –270.37°C

- 6.10 Two reversible heat engines A and B are arranged in series, A rejecting heat directly to B . Engine A receives 200 kJ at a temperature of 421°C from a hot source, while engine B is in communication with a cold sink at a temperature of 4.4°C. If the work output of A is twice that of B , find (a) the intermediate temperature between A and B , (b) the efficiency of each engine, and (c) the heat rejected to the cold sink.

Ans. 143.4°C, 40% & 33.5%, 80 kJ

- 6.11 A heat engine operates between the maximum and minimum temperatures of 671°C and 60°C respectively, with an efficiency of 50% of the appropriate Carnot efficiency. It drives a heat pump which uses river water at 4.4°C to heat a block of flats in which the temperature is to be maintained at 21.1°C. Assuming that a temperature difference of 11.1°C exists between the working fluid and the river water, on the one hand, and the required room temperature on the other, and assuming the heat pump to operate on the reversed Carnot cycle, but with a COP of 50% of the ideal COP, find the heat input to the engine per unit heat output from the heat pump. Why is direct heating thermodynamically more wasteful?

Ans. 0.79 kJ/kJ heat input

- 6.12 An ice-making plant produces ice at atmospheric pressure and at 0°C from water at 0°C. The mean temperature of the cooling water circulating through the condenser of the refrigerating machine is 18°C. Evaluate the minimum electrical work in kWh required to produce 1 tonne of ice. (The enthalpy of fusion of ice at atmospheric pressure is 333.5 kJ/kg).

Ans. 6.11 kWh

- 6.13 A reversible engine works between three thermal reservoirs, A , B and C . The engine absorbs an equal amount of heat from the thermal reservoirs A and B kept at temperatures T_A and T_B respectively, and rejects heat to the thermal reservoir C kept at temperature T_C . The efficiency of the engine is α times the efficiency of the reversible engine, which works between the two reservoirs A and C . Prove that

$$\frac{T_A}{T_B} = (2\alpha - 1) + 2(1 - \alpha) \frac{T_A}{T_C}$$

- 6.14 A reversible engine operates between temperatures T_1 and T ($T_1 > T$). The energy rejected from this engine is received by a second reversible engine at the same temperature T . The second engine rejects energy at temperature T_2 ($T_2 < T$). Show that (a) temperature T is the arithmetic mean of temperatures T_1 and T_2 if the engines produce the same amount of work output, and (b) temperature T is the geometric mean of temperatures T_1 and T_2 if the engines have the same cycle efficiencies.
- 6.15 Two Carnot engines A and B are connected in series between two thermal reservoirs maintained at 1000 K and 100 K respectively. Engine A receives 1680 kJ of heat from the high-temperature reservoir and rejects heat to the Carnot engine B . Engine B takes in heat rejected by engine A and rejects heat to the low-temperature reservoir. If engines A and B have equal thermal efficiencies, determine (a) the heat rejected by engine B , (b) the temperature at which heat is rejected by engine A , and (c) the work done during the process by engines A and B respectively. If engines A and B deliver equal work, determine (d) the amount of heat taken in by engine B , and (e) the efficiencies of engines A and B .

Ans. (a) 168 kJ, (b) 316.2 K, (c) 1148.7, 363.3 kJ, (d) 924 kJ, (e) 45%, 81.8%.

- 6.16 A heat pump is to be used to heat a house in winter and then reversed to cool the house in summer. The interior temperature is to be maintained at 20°C . Heat transfer through the walls and roof is estimated to be 0.525 kJ/s per degree temperature difference between the inside and outside. (a) If the outside temperature in winter is 5°C , what is the minimum power required to drive the heat pump? (b) If the power output is the same as in part (a), what is the maximum outer temperature for which the inside can be maintained at 20°C ?

Ans. (a) 403 W , (b) 35°C .

- 6.17 Consider an engine in outer space which operates on the Carnot cycle. The only way in which heat can be transferred from the engine is by radiation. The rate at which heat is radiated is proportional to the fourth power of the absolute temperature T_2 and to the area of the radiating surface. Show that for a given power output and a given T_1 , the area of the radiator will be a minimum when

$$\frac{T_2}{T_1} = \frac{3}{4}$$

- 6.18 It takes 10 kW to keep the interior of a certain house at 20°C when the outside temperature is 0°C . This heat flow is usually obtained directly by burning gas or oil. Calculate the power required if the 10 kW heat flow were supplied by operating a reversible heat pump with the house as the upper reservoir and the outside surroundings as the lower reservoir.

Ans. 0.6826 kW

- 6.19 Prove that the COP of a reversible refrigerator operating between two given temperatures is the maximum.

- 6.20 A house is to be maintained at a temperature of 20°C by means of a heat pump pumping heat from the atmosphere. Heat losses through the walls of the house are estimated at 0.65 kW per unit of temperature difference between the inside of the house and the atmosphere. (a) If the atmospheric temperature is -10°C , what is the minimum power required to drive the pump? (b) It is proposed to use the same heat pump to cool the house in summer. For the same room temperature, the same heat loss rate, and the same power input to the pump, what is the maximum permissible atmospheric temperature?

Ans. 2 kW , 50°C .

- 6.21 A solar-powered heat pump receives heat from a solar collector at T_h , rejects heat to the atmosphere at T_a , and pumps heat from a cold space at T_c . The three heat transfer rates are Q_h , Q_a , and Q_c respectively. Derive an expression for the minimum ratio Q_h/Q_c , in terms of the three temperatures.

If $T_h = 400\text{ K}$, $T_a = 300\text{ K}$, $T_c = 200\text{ K}$, $Q_c = 12\text{ kW}$, what is the minimum Q_h ? If the collector captures 0.2 kW/m^2 , what is the minimum collector area required?

Ans. 24 kW , 120 m^2

- 6.22 A heat engine operating between two reservoirs at 1000 K and 300 K is used to drive a heat pump which extracts heat from the reservoir at 300 K at a rate twice that at which the engine rejects heat to it. If the efficiency of the engine is 40% of the maximum possible and the COP of the heat pump is 50% of the maximum possible, what is the temperature of the reservoir to which the heat pump rejects heat? What is the rate of heat rejection from the heat pump if the rate of heat supply to the engine is 50 kW ?

Ans. 326.5 K , 86 kW

- 6.23 A reversible power cycle is used to drive a reversible heat pump cycle. The power cycle takes in Q_1 heat units at T_1 and rejects Q_2 at T_2 . The heat pump abstracts Q_4 from the sink at T_4 and discharges Q_3 at T_3 . Develop an expression for the ratio Q_4/Q_1 in terms of the four temperatures.

$$\text{Ans. } \frac{Q_4}{Q_1} = \frac{T_4(T_1 - T_2)}{T_1(T_3 - T_4)}$$

- 6.24 Prove that the following propositions are logically equivalent: (a) A PMM2 is impossible, (b) A weight sliding at constant velocity down a frictional inclined plane executes an irreversible process.
- 6.25 A heat engine receives half of its heat supply at 1000 K and half at 500 K while rejecting heat to a sink at 300 K. What is the maximum possible thermal efficiency of this heat engine?

Ans. 0.55

- 6.26 A heat pump provides 3×10^4 kJ/h to maintain a dwelling at 23°C on a day when the outside temperature is 0°C . The power input to the heat pump is 4 kW. Determine the COP of the heat pump and compare it with the COP of a reversible heat pump operating between the reservoirs at the same two temperatures.

Ans. 2.08, 12.87

- 6.27 A reversible power cycle receiver energy Q_1 from a reservoir at temperature T_1 and rejects Q_2 to a reservoir at temperature T_2 . The work developed by the power cycle is used to drive a reversible heat pump that removes energy Q'_2 from a reservoir at temperature T'_2 and rejects energy Q'_1 to a reservoir at temperature T'_1 . (a) Determine an expression for the ratio Q'_1/Q_1 in terms of the four temperatures. (b) What must be the relationship of the temperatures T_1 , T_2 , T'_2 and T'_1 for Q'_1/Q_1 to exceed a value of unity?

$$\text{Ans. (a) } \frac{Q'_1}{Q_1} = \frac{T'_1(T_1 - T_2)}{T_1(T'_1 - T'_2)}, \text{ (b) } \frac{T_2}{T'_2} < \frac{T_1}{T'_1}$$

- 6.28 When the outside temperature is -10°C , a residential heat pump must provide 3.5×10^6 kJ per day to a dwelling to maintain its temperature at 20°C . If electricity costs Rs. 2.10 per kWh, find the minimum theoretical operating cost for each day of operation.

Ans. Rs. 208.83

7

Entropy

7.1 Introduction

The first law of thermodynamics was stated in terms of cycles first and it was shown that the cyclic integral of heat is equal to the cyclic integral of work. When the first law was applied for thermodynamic processes, the existence of a property, the internal energy, was found. Similarly, the second law was also first stated in terms of cycles executed by systems. When applied to processes, the second law also leads to the definition of a new property, known as entropy. If the first law is said to be the law of internal energy, then second law may be stated to be the law of entropy. In fact, *thermodynamics is the study of three E's, namely, energy, equilibrium and entropy.*

7.2 Two Reversible Adiabatic Paths Cannot Intersect Each Other

Let it be assumed that two reversible adiabatics AC and BC intersect each other at point C (Fig. 7.1). Let a reversible isotherm AB be drawn in such a way that it intersects the reversible adiabatics at A and B . The three reversible processes AB , BC , and CA together constitute a reversible cycle, and the area included represents the net work output in a cycle. But such a cycle is impossible, since net work is being produced in a cycle by a heat engine by exchanging heat with a single reservoir in the process AB , which violates the Kelvin-Planck statement of the second law. Therefore, the assumption of the intersection of the reversible adiabatics is wrong. *Through one point, there can pass only one reversible adiabatic.*

Since two constant property lines can never intersect each other, it is inferred that a reversible adiabatic path must represent some property, which is yet to be identified.

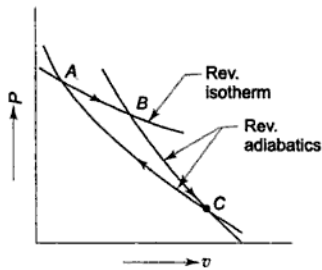

Fig. 7.1 Assumption of two reversible adiabats intersecting each other

7.3 Clausius' Theorem

Let a system be taken from an equilibrium state i to another equilibrium state f by following the reversible path $i-f$ (Fig. 7.2). Let a reversible adiabat $i-a$ be drawn through i and another reversible adiabat $b-f$ be drawn through f . Then a reversible isotherm $a-b$ is drawn in such a way that the area under $i-a-b-f$ is equal to the area under $i-f$. Applying the first law for

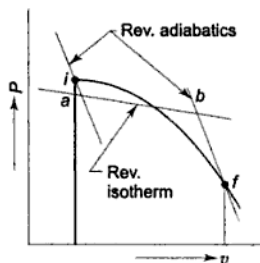

Fig. 7.2 Reversible path substituted by two reversible adiabats and a reversible isotherm

Process $i-f$

$$Q_{i-f} = U_f - U_i + W_{if} \quad (7.1)$$

Process $i-a-b-f$

$$Q_{iabf} = U_f - U_i + W_{iabf} \quad (7.2)$$

Since

$$W_{if} = W_{iabf}$$

\therefore From Eqs (7.1) and (7.2)

$$\begin{aligned} Q_{if} &= Q_{iabf} \\ &= Q_{ia} + Q_{ab} + Q_{bf} \end{aligned}$$

Since

$$Q_{ia} = 0 \text{ and } Q_{bf} = 0$$

$$Q_{if} = Q_{ab}$$

Heat transferred in the process $i-f$ is equal to the heat transferred in the isothermal process $a-b$.

Thus any reversible path may be substituted by a reversible zigzag path, between the same end states, consisting of a reversible adiabat followed by a reversible isotherm and then by a reversible adiabat, such that the heat transferred during the isothermal process is the same as that transferred during the original process.

Let a smooth closed curve representing a reversible cycle (Fig. 7.3) be considered. Let the closed cycle be divided into a large number of strips by means of reversible adiabats. Each strip may be closed at the top and bottom by reversible isotherms. The original closed cycle is thus replaced by a zigzag closed path consisting of alternate adiabatic and isothermal processes, such that the heat transferred during all the isothermal processes is equal to the heat transferred in the original cycle. Thus the original cycle is replaced by a large number of Carnot cycles. If the adiabatics are close to one another and the number of Carnot cycles is large, the saw-toothed zigzag line will coincide with the original cycle.

For the elemental cycle $abcd$, dQ_1 heat is absorbed reversibly at T_1 , and dQ_2 heat is rejected reversibly at T_2

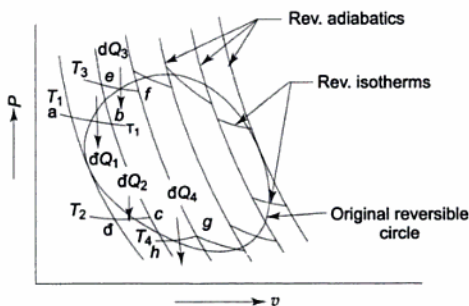

Fig. 7.3 A reversible cycle split into a large number of Carnot cycles

$$\frac{dQ_1}{T_1} = \frac{dQ_2}{T_2}$$

If heat supplied is taken as positive and heat rejected as negative

$$\frac{dQ_1}{T_1} + \frac{dQ_2}{T_2} = 0$$

Similarly, for the elemental cycle $efgh$

$$\frac{dQ_3}{T_3} + \frac{dQ_4}{T_4} = 0$$

If similar equations are written for all the elemental Carnot cycles, then for the whole original cycle

$$\frac{dQ_1}{T_1} + \frac{dQ_2}{T_2} + \frac{dQ_3}{T_3} + \frac{dQ_4}{T_4} + \dots = 0$$

or
$$\oint_R \frac{dQ}{T} = 0 \quad (7.3)$$

The cyclic integral of dQ/T for a reversible cycle is equal to zero. This is known as *Clausius' theorem*. The letter R emphasizes the fact that the equation is valid only for a reversible cycle.

7.4 The Property of Entropy

Let a system be taken from an initial equilibrium state i to a final equilibrium state f by following the reversible path R_1 (Fig. 7.4). The system is brought

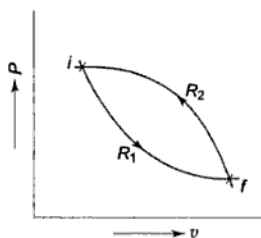

Fig. 7.4 Two reversible paths R_1 and R_2 between two equilibrium states i and f

back from f to i by following another reversible path R_2 . Then the two paths R_1 and R_2 together constitute a reversible cycle. From Clausius' theorem

$$\oint_{R_1 R_2} \frac{dQ}{T} = 0$$

The above integral may be replaced as the sum of two integrals, one for path R_1 and the other for path R_2

$$\int_{R_1}^f \frac{dQ}{T} + \int_{R_2}^i \frac{dQ}{T} = 0$$

or
$$\int_{R_1}^f \frac{dQ}{T} = - \int_{R_2}^i \frac{dQ}{T}$$

Since R_2 is a reversible path

$$\int_{R_1}^f \frac{dQ}{T} = \int_{R_2}^f \frac{dQ}{T}$$

Since R_1 and R_2 represent any two reversible paths, $\int_{i,R}^f \frac{dQ}{T}$ is independent of

the reversible path connecting i and f . Therefore, there exists a property of a system whose value at the final state f minus its value at the initial state i is equal to $\int_{i,R}^f \frac{dQ}{T}$. This property is called *entropy*, and is denoted by S . If S_i is the entropy

at the initial state i , and S_f is the entropy at the final state f , then

$$\int_{i,R}^f \frac{dQ}{T} = S_f - S_i \quad (7.4)$$

When the two equilibrium states are infinitesimally near

$$\frac{dQ_R}{T} = dS \quad (7.5)$$

where dS is an *exact differential* because S is a point function and a property. The subscript R in dQ indicates that heat dQ is transferred *reversibly*.

The word 'entropy' was first used by Clausius, taken from the Greek word 'tropee' meaning 'transformation'. It is an extensive property, and has the unit J/K. The specific entropy

$$s = \frac{S}{m} \text{ J/kg K}$$

If the system is taken from an initial equilibrium state i to a final equilibrium state f by an *irreversible path*, since entropy is a point or state function, and the entropy change is independent of the path followed, the non-reversible path is to be replaced by a reversible path to integrate for the evaluation of entropy change in the irreversible process (Fig. 7.5).

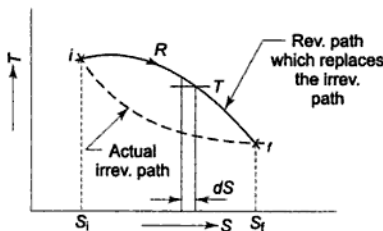

Fig. 7.5 Integration can be done only on a reversible path

$$S_f - S_i = \int_i^f \frac{dQ_{\text{rev}}}{T} = (\Delta S)_{\text{irrev path}} \quad (7.6)$$

Integration can be performed only on a reversible path.

7.4.1 Temperature-Entropy Plot

The infinitesimal change in entropy dS due to reversible heat transfer dQ at temperature T is

$$dS = \frac{dQ_{\text{rev}}}{T}$$

If $dQ_{\text{rev}} = 0$, i.e., the process is reversible and adiabatic

$$dS = 0$$

and

$$S = \text{constant}$$

A reversible adiabatic process is, therefore, an isentropic process.

Now

$$dQ_{\text{rev}} = TdS$$

or

$$Q_{\text{rev}} = \int_i^f TdS$$

The system is taken from i to f reversibly (Fig. 7.6). The area under the curve $\int_i^f T dS$ is equal to the heat transferred in the process.

For reversible isothermal heat transfer (Fig. 7.7), $T = \text{constant}$.

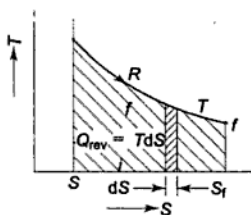

Fig. 7.6 Area under a reversible path on the T - s plot represents heat transfer

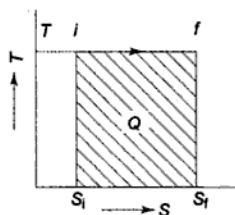

Fig. 7.7 Reversible isothermal heat transfer

$$\therefore Q_{\text{rev}} = T \int_i^f dS = T(S_f - S_i)$$

For a reversible adiabatic process, $dS = 0$, $S = C$ (Fig. 7.8).

The Carnot cycle comprising two reversible isotherms and two reversible adiabatics forms a rectangle in the T - S plane (Fig. 7.9). Process 4-1 represents reversible isothermal heat addition Q_1 to the system at T_1 from an external

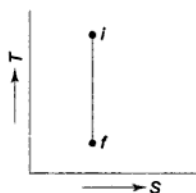

Fig. 7.8 Reversible adiabatic is isentropic

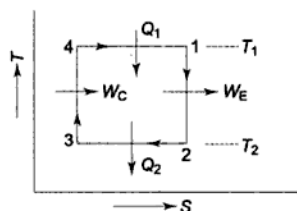

Fig. 7.9 Carnot cycle

source, process 1–2 is the reversible adiabatic expansion of the system producing W_E amount of work, process 2–3 is the reversible isothermal heat rejection from the system to an external sink at T_2 , and process 3–4 represents reversible adiabatic compression of the system consuming W_c amount of work. Area 1 2 3 4 represents the net work output per cycle and the area under 4–1 indicates the quantity of heat added to the system Q_1 .

$$\begin{aligned} \therefore \eta_{\text{Carnot}} &= \frac{Q_1 - Q_2}{Q_1} = \frac{T_1(S_1 - S_4) - T_2(S_2 - S_3)}{T_1(S_1 - S_4)} \\ &= \frac{T_1 - T_2}{T_1} = 1 - \frac{T_2}{T_1} \end{aligned}$$

and

$$W_{\text{net}} = Q_1 - Q_2 = (T_1 - T_2)(S_1 - S_4)$$

7.5 Principle of Caratheodory

The property “entropy” was here introduced through the historical route as initiated by the engineer Carnot and elaborated by the physicists Kelvin and Clausius. Starting with the statement expressing the impossibility of converting heat completely into work, or the impossibility of spontaneous heat flow from a colder to a hotter body, an ideal heat engine of maximum efficiency was described. With the aid of this ideal engine, an absolute temperature scale was defined and the Clausius theorem proved. On the basis of the Clausius theorem, the existence of an entropy function was inferred.

In 1909, the Greek mathematician Caratheodory proved the existence of an entropy function without the aid of Carnot engines and refrigerators, but only by mathematical deduction. Let us consider a system whose states are determined by three thermodynamic coordinates x , y and z . Then the first law in differential form may be written as

$$dQ = A dx + B dy + C dz,$$

where A , B , and C are functions of x , y and z . The adiabatic, reversible transition of this system is subject to the condition

$$dQ = A dx + B dy + C dz = 0$$

which leads to the mathematical statement of the second law as:

In the neighbourhood of any arbitrary initial state P_0 of a physical system there exist neighbouring states which are not accessible from P_0 along quasi-static adiabatic paths.

It follows from Caratheodory's theorem that this is possible if and only if there exist functions T and S such that:

$$\delta Q = A dx + B dy + C dz = T dS$$

Thus, by stating the second law in terms of the inaccessibility of certain states by adiabatic paths, and by using a mathematical theorem (for the proof see Hsieh), Caratheodory inferred the existence of an entropy function and an integrating factor connected with the Kelvin temperature.

7.6 The Inequality of Clausius

Let us consider a cycle $ABCD$ (Fig. 7.10). Let AB be a general process, either reversible or irreversible, while the other processes in the cycle are reversible. Let the cycle be divided into a number of elementary cycles, as shown. For one of these elementary cycles

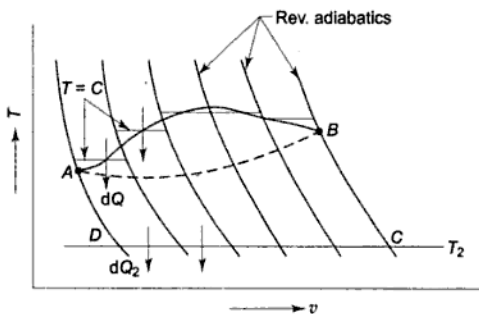

Fig. 7.10 Inequality of Clausius

$$\eta = 1 - \frac{dQ_2}{dQ}$$

where dQ is the heat supplied at T , and dQ_2 the heat rejected at T_2 .

Now, the efficiency of a general cycle will be equal to or less than the efficiency of a reversible cycle.

$$\therefore 1 - \frac{dQ_2}{dQ} \leq \left(1 - \frac{dQ_2}{dQ} \right)_{\text{rev}}$$

$$\text{or} \quad \frac{dQ_2}{dQ} \geq \left(\frac{dQ_2}{dQ} \right)_{\text{rev}}$$

$$\text{or} \quad \frac{dQ}{dQ_2} \leq \left(\frac{dQ}{dQ_2} \right)_{\text{rev}}$$

$$\text{Since} \quad \left(\frac{dQ}{dQ_2} \right)_{\text{rev}} = \frac{T}{T_2}$$

$$\therefore \quad \frac{dQ}{dQ_2} \leq \frac{T}{T_2}$$

or $\frac{dQ}{T} \leq \frac{dQ_2}{T_2}$, for any process AB , reversible or irreversible.

For a reversible process

$$ds = \frac{dQ_{\text{rev}}}{T} = \frac{dQ_2}{T_2} \quad (7.7)$$

Hence, for any process AB

$$\frac{dQ}{T} \leq ds \quad (7.8)$$

Then for any cycle

$$\oint \frac{dQ}{T} \leq \oint ds$$

Since entropy is a property and the cyclic integral of any property is zero

$$\oint \frac{dQ}{T} \leq 0 \quad (7.9)$$

This equation is known as the *inequality of Clausius*. It provides the criterion of the reversibility of a cycle.

If $\oint \frac{dQ}{T} = 0$, the cycle is reversible,

$\oint \frac{dQ}{T} < 0$, the cycle is irreversible and possible

$\oint \frac{dQ}{T} > 0$, the cycle is impossible, since it violates the second law.

7.7 Entropy Change in an Irreversible Process

For any process undergone by a system, we have from Eq. (7.8)

$$\frac{dQ}{T} \leq ds$$

or
$$ds \geq \frac{dQ}{T} \quad (7.10)$$

This is further clarified if we consider the cycles as shown in Fig. 7.11,

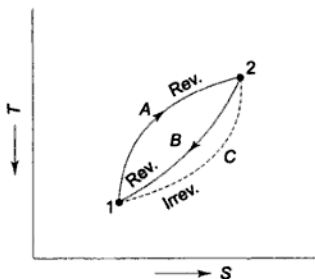

Fig. 7.11 Entropy change in an irreversible process

where *A* and *B* are reversible processes and *C* is an irreversible process. For the reversible cycle consisting of *A* and *B*

$$\int_R \frac{dQ}{T} = \int_1^2 \frac{dQ}{T} + \int_2^1 \frac{dQ}{T} = 0$$

or
$$\int_1^2 \frac{dQ}{T} = - \int_2^1 \frac{dQ}{T} \quad (7.11)$$

For the irreversible cycle consisting of *A* and *C*, by the inequality of Clausius,

$$\oint \frac{dQ}{T} = \int_1^2 \frac{dQ}{T} + \int_2^1 \frac{dQ}{T} < 0 \quad (7.12)$$

From Eqs (7.11) and (7.12),

$$-\int_B^1 \frac{dQ}{T} + \int_C^1 \frac{dQ}{T} < 0$$

$$\therefore \int_B^1 \frac{dQ}{T} > \int_C^1 \frac{dQ}{T} \quad (7.13)$$

Since the path B is reversible,

$$\int_B^1 \frac{dQ}{T} = \int_B^1 dS \quad (7.14)$$

Since entropy is a property, entropy changes for the paths B and C would be the same. Therefore,

$$\int_B^1 dS = \int_C^1 dS \quad (7.15)$$

From Eqs (7.13) to (7.15),

$$\int_C^1 dS > \int_C^1 \frac{dQ}{T}$$

Thus, for any irreversible process,

$$dS > \frac{dQ}{T}$$

whereas for a reversible process

$$dS = \frac{dQ_{\text{rev}}}{T}$$

Therefore, for the general case, we can write

$$dS \geq \frac{dQ}{T}$$

$$\text{or} \quad S_2 - S_1 \geq \int_1^2 \frac{dQ}{T} \quad (7.16)$$

The equality sign holds good for a reversible process and the inequality sign for an irreversible process.

7.8 Entropy Principle

For any infinitesimal process undergone by a system, we have from Eq. (7.10) for the total mass

$$dS \geq \frac{dQ}{T}$$

For an isolated system which does not undergo any energy interaction with the surroundings, $dQ = 0$.

Therefore, for an isolated system

$$dS_{\text{iso}} \geq 0 \quad (7.17)$$

For a reversible process,

$$dS_{\text{iso}} = 0$$

or

$$S = \text{constant}$$

For an irreversible process

$$dS_{\text{iso}} > 0$$

It is thus proved that *the entropy of an isolated system can never decrease*. It always increases and remains constant only when the process is reversible. This is known as the *principle of increase of entropy*, or simply the *entropy principle*. It is the quantitative general statement of second law from the macroscopic viewpoint.

An isolated system can always be formed by including any system and its surroundings within a single boundary (Fig. 7.12). Sometimes the original system which is then only a part of the isolated system is called a 'subsystem'.

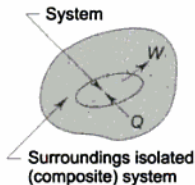

Fig. 7.12 *Isolated system*

The system and the surroundings together (the universe or the isolated system) include everything which is affected by the process. For all possible processes that a system in the given surroundings can undergo

$$dS_{\text{univ}} \geq 0$$

or

$$dS_{\text{sys}} + dS_{\text{surr}} \geq 0 \quad (7.18)$$

Entropy may decrease locally at some region within the isolated system, but it must be compensated by a greater increase of entropy somewhere within the system so that the net effect of an irreversible process is an entropy increase of

the whole system. The entropy increase of an isolated system is a measure of the extent of irreversibility of the process undergone by the system.

Rudolf Clausius summarized the first and second laws of thermodynamics in the following words:

- (a) Die Energie der Welt ist Constant.
- (b) Die Entropie der Welt strebt einem Maximum zu.
- [(a) The energy of the world (universe) is constant.
- (b) The entropy of the world tends towards a maximum.]

The entropy of an isolated system always increases and becomes a maximum at the state of equilibrium. If the entropy of an isolated system varies with some parameter x , then there is a certain value of x_e which maximizes the entropy (when $\frac{dS}{dx} = 0$) and represents the equilibrium state (Fig. 7.13). The system is then said to exist at the peak of the entropy hill, and $dS = 0$. *When the system is at equilibrium, any conceivable change in entropy would be zero.*

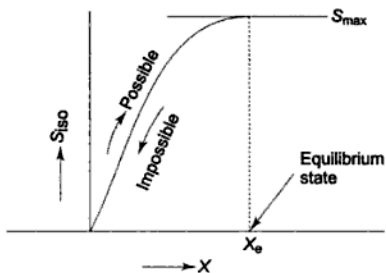

Fig. 7.13 Equilibrium state of an isolated system

7.9 Applications of Entropy Principle

The principle of increase of entropy is one of the most important laws of physical science. It is the quantitative statement of the second law of thermodynamics. Every irreversible process is accompanied by entropy increase of the universe, and this entropy increase quantifies the extent of irreversibility of the process. The higher the entropy increase of the universe, the higher will be the irreversibility of the process. A few applications of the entropy principle are illustrated in the following.

7.9.1 Transfer of heat through a Finite Temperature Difference

Let Q be the rate of heat transfer from reservoir A at T_1 to reservoir B at T_2 , $T_1 > T_2$ (Fig. 7.14).

For reservoir A , $\Delta S_A = -Q/T_1$. It is negative because heat Q flows out of the reservoir. For reservoir B , $\Delta S_B = +Q/T_2$. It is positive because heat flows into

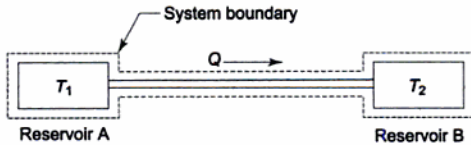

Fig. 7.14 Heat transfer through a finite temperature difference

the reservoir. The rod connecting the reservoirs suffers no entropy change because, once in the steady state, its coordinates do not change.

Therefore, for the isolated system comprising the reservoirs and the rod, and since entropy is an additive property

$$S = S_A + S_B$$

$$\Delta S_{\text{univ}} = \Delta S_A + \Delta S_B$$

or

$$\Delta S_{\text{univ}} = -\frac{Q}{T_1} + \frac{Q}{T_2} = Q \cdot \frac{T_1 - T_2}{T_1 T_2}$$

Since $T_1 > T_2$, ΔS_{univ} is positive, and the process is irreversible and possible. If $T_1 = T_2$, ΔS_{univ} is zero, and the process is reversible. If $T_1 < T_2$, ΔS_{univ} is negative and the process is impossible.

7.9.2 Mixing of Two Fluids

Subsystem 1 having a fluid of mass m_1 , specific heat c_1 , and temperature t_1 , and subsystem 2 consisting of a fluid of mass m_2 , specific heat c_2 , and temperature t_2 , comprise a composite system in an adiabatic enclosure (Fig. 7.15). When the partition is removed, the two fluids mix together, and at

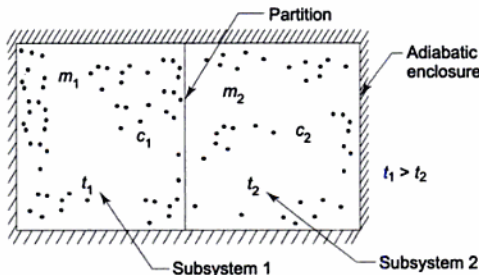

Fig. 7.15 Mixing of two fluids

equilibrium let t_f be the final temperature, and $t_2 < t_f < t_1$. Since energy interaction is exclusively confined to the two fluids, the system being isolated

$$m_1 c_1 (t_1 - t_f) = m_2 c_2 (t_f - t_2)$$

$$\therefore t_f = \frac{m_1 c_1 t_1 + m_2 c_2 t_2}{m_1 c_1 + m_2 c_2}$$

Entropy change for the fluid in subsystem 1

$$\begin{aligned} \Delta S_1 &= \int_{T_1}^{T_f} \frac{dQ_{\text{rev}}}{T} = \int_{T_1}^{T_f} \frac{m_1 c_1 dT}{T} = m_1 c_1 \ln \frac{T_f}{T_1} \\ &= m_1 c_1 \ln \frac{t_f + 273}{t_1 + 273} \end{aligned}$$

This will be negative, since $T_1 > T_f$.

Entropy change for the fluid in subsystem 2

$$\Delta S_2 = \int_{T_2}^{T_f} \frac{m_2 c_2 dT}{T} = m_2 c_2 \ln \frac{T_f}{T_2} = m_2 c_2 \ln \frac{t_f + 273}{t_2 + 273}$$

This will be positive, since $T_2 < T_f$.

$$\begin{aligned} \therefore \Delta S_{\text{univ}} &= \Delta S_1 + \Delta S_2 \\ &= m_1 c_1 \ln \frac{T_f}{T_1} + m_2 c_2 \ln \frac{T_f}{T_2} \end{aligned}$$

ΔS_{univ} will be positive definite, and the mixing process is irreversible.

Although the mixing process is irreversible, to evaluate the entropy change for the subsystems, the irreversible path was replaced by a reversible path on which the integration was performed.

If $m_1 = m_2 = m$ and $c_1 = c_2 = c$.

$$\Delta S_{\text{univ}} = mc \ln \frac{T_f^2}{T_1 \cdot T_2}$$

and

$$T_f = \frac{m_1 c_1 T_1 + m_2 c_2 T_2}{m_1 c_1 + m_2 c_2} = \frac{T_1 + T_2}{2}$$

$$\therefore \Delta S_{\text{univ}} = 2 mc \ln \frac{(T_1 + T_2)/2}{\sqrt{T_1 \cdot T_2}}$$

This is always positive, since the arithmetic mean of any two numbers is always greater than their geometric mean. This can also be proved geometrically. Let a semi-circle be drawn with $(T_1 + T_2)$ as diameter (Fig. 7.16).

Here, $AB = T_1$, $BC = T_2$ and $OE = (T_1 + T_2)/2$. It is known that $(DB)^2 = AB \cdot BC = T_1 T_2$.

$$\therefore DB = \sqrt{T_1 T_2}$$

Now, $OE > DB$

$$\frac{T_1 + T_2}{2} = \sqrt{T_1 T_2}$$

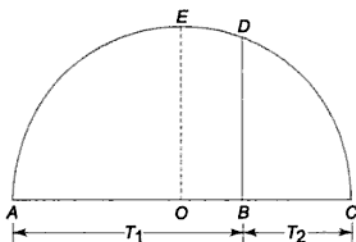

Fig. 7.16 Geometrical proof to show that $g.m < a.m.$

7.9.3 Maximum Work Obtainable from Two Finite Bodies at Temperatures T_1 and T_2

Let us consider two identical finite bodies of constant heat capacity at temperatures T_1 and T_2 respectively, T_1 being higher than T_2 . If the two bodies are merely brought together into thermal contact, delivering no work, the final temperature T_f reached would be the maximum

$$T_f = \frac{T_1 + T_2}{2}$$

If a heat engine is operated between the two bodies acting as thermal energy reservoirs (Fig. 7.17), part of the heat withdrawn from body 1 is converted to work W by the heat engine, and the remainder is rejected to body 2. The lowest attainable final temperature T_f corresponds to the delivery of the largest possible amount of work, and is associated with a reversible process.

As work is delivered by the heat engine, the temperature of body 1 will be decreasing and that of body 2 will be increasing. When both the bodies attain the final temperature T_f , the heat engine will stop operating. Let the bodies remain at constant pressure and undergo no change of phase.

Total heat withdrawn from body 1

$$Q_1 = C_p (T_1 - T_f)$$

where C_p is the heat capacity of the two bodies at constant pressure.

Total heat rejected to body 2

$$Q_2 = C_p (T_f - T_2)$$

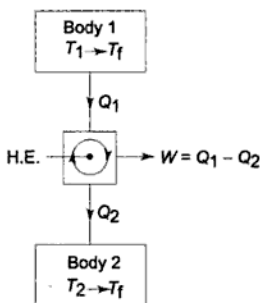

Fig. 7.17 Maximum work obtainable from two finite bodies

∴ Amount of total work delivered by the heat engine

$$\begin{aligned} W &= Q_1 - Q_2 \\ &= C_p (T_1 + T_2 - 2T_f) \end{aligned} \quad (7.19)$$

For given values of C_p , T_1 and T_2 , the magnitude of work W depends on T_f . Work obtainable will be maximum when T_f is minimum.

Now, for body 1, entropy change ΔS_1 is given by

$$\Delta S_1 = \int_{T_1}^{T_f} C_p \frac{dT}{T} = C_p \ln \frac{T_f}{T_1}$$

For body 2, entropy change ΔS_2 would be

$$\Delta S_2 = \int_{T_2}^{T_f} C_p \frac{dT}{T} = C_p \ln \frac{T_f}{T_2}$$

Since the working fluid operating in the heat engine cycle does not undergo any entropy change, ΔS of the working fluid in heat engine = $\oint dS = 0$.

Applying the entropy principle

$$\Delta S_{\text{univ}} \geq 0$$

$$\begin{aligned} \therefore C_p \ln \frac{T_f}{T_1} + C_p \ln \frac{T_f}{T_2} &\geq 0 \\ C_p \ln \frac{T_f^2}{T_1 T_2} &\geq 0 \end{aligned} \quad (7.20)$$

From equation (7.20), for T_f to be a minimum

$$C_p \ln \frac{T_f^2}{T_1 T_2} = 0$$

Since $C_p \neq 0$,

$$\ln \frac{T_f^2}{T_1 T_2} = 0 = \ln 1$$

$$\therefore T_f = \sqrt{T_1 T_2} \quad (7.21)$$

For W to be a maximum, T_f will be $\sqrt{T_1 T_2}$. From equation (7.19)

$$W_{\text{max}} = C_p (T_1 + T_2 - 2\sqrt{T_1 T_2}) = C_p (\sqrt{T_1} - \sqrt{T_2})^2$$

The final temperatures of the two bodies, initially at T_1 and T_2 , can range from $(T_1 + T_2)/2$ with no delivery of work to $\sqrt{T_1 T_2}$ with maximum delivery of work.

7.9.4 Maximum Work Obtainable from a Finite Body and a TER

Let one of the bodies considered in the previous section be a thermal energy reservoir. The finite body has a thermal capacity C_p and is at temperature T and

the TER is at temperature T_0 , such that $T > T_0$. Let a heat engine operate between the two (Fig. 7.18). As heat is withdrawn from the body, its temperature decreases. The temperature of the TER would, however, remain unchanged at T_0 . The engine would stop working, when the temperature of the body reaches T_0 . During that period, the amount of work delivered is W , and the heat rejected to the TER is $(Q - W)$. Then

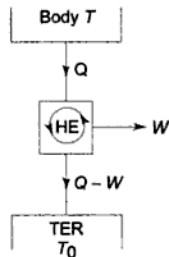

Fig. 7.18 Maximum work obtainable when one of the bodies is a TER

$$\Delta S_{\text{Body}} = \int_T^{T_0} C_p \frac{dT}{T} = C_p \ln \frac{T_0}{T}$$

$$\Delta S_{\text{HE}} = \oint dS = 0$$

$$\Delta S_{\text{TER}} = \frac{Q - W}{T_0}$$

$$\therefore \Delta S_{\text{univ}} = C_p \ln \frac{T_0}{T} + \frac{Q - W}{T_0}$$

By the entropy principle,

$$\Delta S_{\text{univ}} \geq 0$$

$$C_p \ln \frac{T_0}{T} + \frac{Q - W}{T_0} \geq 0$$

or
$$C_p \ln \frac{T_0}{T} \geq \frac{W - Q}{T_0}$$

or
$$\frac{W - Q}{T_0} \leq C_p \ln \frac{T_0}{T}$$

or
$$W \leq Q + T_0 C_p \ln \frac{T_0}{T}$$

$$\therefore W_{\text{max}} = Q + T_0 C_p \ln \frac{T_0}{T}$$

or,
$$W_{\text{max}} = C_p \left[(T - T_0) - T_0 \ln \frac{T}{T_0} \right] \quad (7.22)$$

7.9.5 Processes Exhibiting External Mechanical Irreversibility

(i) **Isothermal Dissipation of Work** Let us consider the isothermal dissipation of work through a system into the internal energy of a reservoir, as in the flow of an electric current I through a resistor in contact with a reservoir

(Fig. 7.19). At steady state, the internal energy of the resistor and hence its temperature is constant. So, by first law

$$W = Q$$

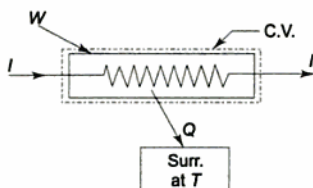

Fig. 7.19 External mechanical irreversibility

The flow of current represents work transfer. At steady state the work is dissipated isothermally into heat transfer to the surroundings. Since the surroundings absorb Q units of heat at temperature T ,

$$\Delta S_{\text{surr}} = \frac{Q}{T} = \frac{W}{T}$$

At steady state, $\Delta S_{\text{sys}} = 0$

$$\therefore \Delta S_{\text{univ}} = \Delta S_{\text{sys}} + \Delta S_{\text{surr}} = \frac{W}{T} \quad (7.23)$$

The irreversible process is thus accompanied by an entropy increase of the universe.

(ii) **Adiabatic Dissipation of Work** Let W be the stirring work supplied to a viscous thermally insulated liquid, which is dissipated adiabatically into internal energy increase of the liquid, the temperature of which increases from T_i to T_f (Fig. 7.20). Since there is no flow of heat to or from the surroundings,

$$\Delta S_{\text{surr}} = 0$$

To calculate the entropy change of the system, the original irreversible path (dotted line) must be replaced by a reversible one between the same end states,

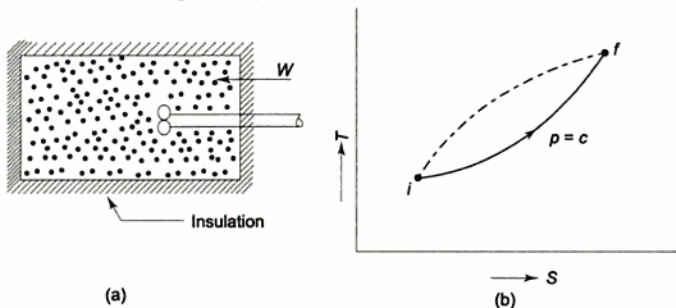

Fig. 7.20 Adiabatic dissipation of work

i and f . Let us replace the irreversible performance of work by a reversible isobaric flow of heat from a series of reservoirs ranging from T_i to T_f to cause the same change in the state of the system. The entropy change of the system will be

$$\Delta S_{\text{sys}} = \int_{i, R}^f \frac{dQ}{T} = \int_{i, R}^f \frac{C_p dT}{T} = C_p \ln \frac{T_f}{T_i}$$

where C_p is the heat capacity of the liquid.

$$\Delta S_{\text{univ}} = \Delta S_{\text{sys}} + \Delta S_{\text{surr}} = C_p \ln \frac{T_f}{T_i} \quad (7.24)$$

which is positive.

7.10 Entropy Transfer Mechanisms

Entropy can be *transferred* to or from a system in two forms: *heat transfer* and *mass flow*. In contrast, energy is transferred by work also. Entropy transfer is recognised at the system boundary as entropy crosses the boundary, and it represents the entropy gained or lost by a system during a process. The only form of entropy interaction associated with a fixed mass or closed system is heat transfer, and thus the entropy transfer for an adiabatic closed system is zero. It is being explained below in more details:

(a) Heat Transfer Since $dS = \frac{dQ_{\text{rev}}}{T}$, when heat is added to a system dQ is positive, and the entropy of the system increases. When heat is removed from the system, dQ is negative, and the entropy of the system decreases.

Heat transferred to the system of fixed mass increases the internal energy of the system, as a result of which the molecules (of a gas) move with higher kinetic energy and collide more frequently, and so the disorder in the system increases. Heat is thus regarded as disorganised or disordered energy transfer which increases molecular chaos (see Sec. 7.16). If heat Q flows reversibly from the system to the surroundings at T_0 (Fig. 7.21), the entropy increase of the surroundings is

$$\Delta S_{\text{surr}} = \frac{Q}{T_0}$$

The entropy of the system is reduced by

$$\Delta S_{\text{sys}} = -\frac{Q}{T_0}$$

The temperature of the boundary where heat transfer occurs is the constant temperature T_0 . It may be said that the system has lost entropy to the surroundings. Alternatively, one may state that the surroundings have gained

entropy from the system. Therefore, there is *entropy transfer* from the system to the surroundings along with heat flow. In other words, since the heat inflow increases the molecular disorder, there is flow of disorder along with heat. The sign of entropy transfer is the same as the sign of heat transfer: *positive*, if into the system, and *negative*, if out of the system.

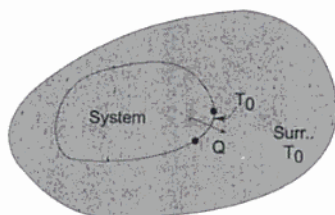

Fig. 7.21 Entropy transfer along with heat flow

On the other hand, *there is no entropy transfer associated with work*. In Fig. 7.22, the system delivers work to a flywheel, where energy is stored in a fully recoverable form. The flywheel molecules are simply put into rotation around the axis in a perfectly organised manner, and there is no dissipation and hence no entropy increase of the flywheel. The same can be said about work transfer in the compression of a spring or in the raising of a weight by a certain height. There is thus no entropy transfer along with work. If work is dissipated adiabatically into internal energy increase of the system (Subsection 7.9.5), there is an entropy increase in the system, but there is as such no entropy transfer to it.

Work is thus *entropy-free*, and no entropy is transferred with work. Energy is transferred with both heat and work, whereas entropy is transferred only with heat. The first law of thermodynamics makes no distinction between heat transfer and work. It considers them as *equals*. The distinction between heat transfer and work is brought about by the second law: *an energy interaction which is accompanied by entropy transfer is heat transfer, and an energy interaction which is not accompanied by entropy transfer is work. Thus, only energy is exchanged during work interaction, whereas both energy and entropy are exchanged during heat transfer.*

(b) Mass Flow Mass contains entropy as well as energy, and the entropy and energy of a system are proportional to the mass. When the mass of a system is doubled, so are the entropy and energy of the system. Both entropy and energy are carried into or out of a system by streams of matter, and the rates of entropy and energy transport into or out of a system are proportional to the mass flow rate. Closed systems do not involve any mass flow and thus any entropy transport. When an amount of mass m enters or leaves a system, an entropy of amount ms , s being the specific entropy, accompanies it. Therefore, the entropy of a system increases by ms when the mass of amount m enters it, and decreases by the same amount when it leaves it at the same state.

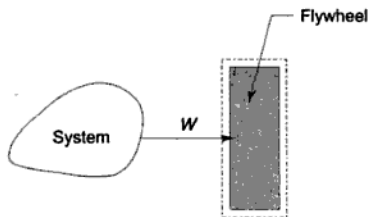

Fig. 7.22 No entropy transfer along with work transfer

7.11 Entropy Generation in a Closed System

The entropy of any closed system can increase in two ways:

- by heat interaction in which there is entropy transfer
- internal irreversibilities or dissipative effects in which work (or K.E.) is dissipated into internal energy increase.

If dQ is the infinitesimal amount of heat transferred to the system through its boundary at temperature T , the same as that of the surroundings, the entropy increase dS of the system can be expressed as

$$\begin{aligned} dS &= d_e S + d_i S \\ &= \frac{dQ}{T} + d_i S \end{aligned} \quad (7.25)$$

where $d_e S$ is the entropy increase due to external heat interaction and $d_i S$ is the entropy increase due to internal irreversibility. From Eq. (7.25),

$$\begin{aligned} dS &\geq \frac{dQ}{T} \\ \therefore d_i S &\geq 0 \end{aligned} \quad (7.26)$$

The entropy increase due to internal irreversibility is also called entropy production or entropy generation, S_{gen} .

In other words, the entropy change of a system during a process is greater than the entropy transfer (dQ/T) by an amount equal to the entropy generated during the process within the system ($d_i S$), so that the *entropy balance* gives:

Entropy change = Entropy transfer + Entropy generation

$$\Delta S_{\text{system}} = \Delta S_{\text{transfer}} + \Delta S_{\text{gen}}$$

which is a verbal statement of Eq. (7.25) and illustrated in Fig. 7.23.

It may so happen that in a process (e.g., the expansion of a hot fluid in a turbine) the entropy decrease of the system due to heat loss to the surroundings

$\left(-\int \frac{dQ}{T}\right)$ is equal to the entropy increase of the system due to internal

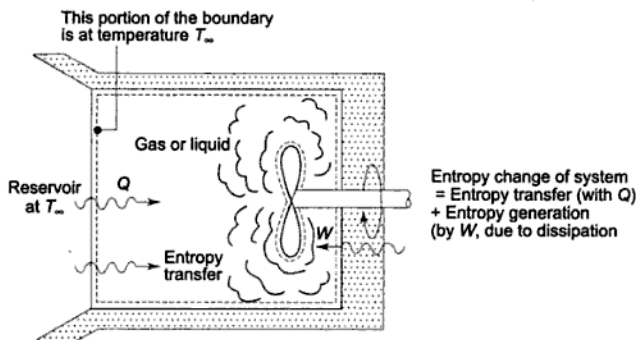

Fig. 7.23 Illustration of the entropy transfer and entropy production concepts.

irreversibilities such as friction, etc. ($\int d_i S$), in which case the entropy of the system before and after the process will remain the same ($\int dS = 0$). Therefore, an isentropic process need not be adiabatic or reversible.

But if the isentropic process is reversible, it must be adiabatic. Also, if the isentropic process is adiabatic, it cannot but be reversible. An adiabatic process need not be isentropic, since entropy can also increase due to friction etc. But if the process is adiabatic and reversible, it must be isentropic.

For an infinitesimal reversible process by a closed system,

$$\delta Q_R = dU_R + pdV$$

If the process is irreversible,

$$\delta Q_I = dU_I + \delta W$$

Since U is a property,

$$dU_R = dU_I$$

$$\therefore \delta Q_R - pdV = \delta Q_I - \delta W$$

$$\text{or} \quad \left(\frac{\delta Q}{T} \right)_R = \left(\frac{\delta Q}{T} \right)_I + \frac{pdV - \delta W}{T} \quad (7.27)$$

The difference $(pdV - \delta W)$ indicates the work that is lost due to irreversibility, and is called the *lost work* $\delta(LW)$, which approaches zero as the process approaches reversibility as a limit. Equation (7.27) can be expressed in the form

$$dS = d_e S + d_i S$$

Thus the entropy of a closed system increases due to heat addition ($d_e S$) and internal dissipation ($d_i S$).

In any process executed by a system, energy is always conserved, but entropy is produced internally. For any process between equilibrium states 1 and 2 (Fig. 7.24), the first law can be written as

$$\int_1^2 \underset{\text{Energy transfer}}{dQ} - \int_1^2 \underset{\text{Energy change}}{dW} = E_2 - E_1$$

or

$$Q_{1-2} = E_2 - E_1 + W_{1-2}$$

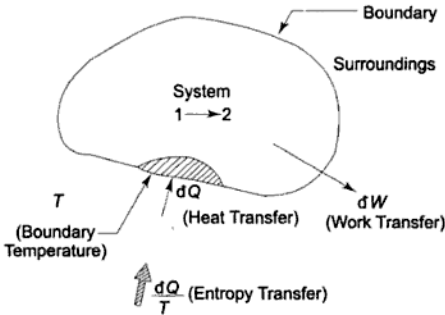

Fig. 7.24 Schematic of a closed system interacting with its surroundings

By the second law,

$$S_2 - S_1 \geq \int_1^2 \frac{dQ}{T}$$

It is only the transfer of energy as heat which is accompanied by entropy transfer, both of which occur at the boundary where the temperature is T . Work interaction is not accompanied by any entropy transfer. The entropy

change of the system ($S_2 - S_1$) exceeds the entropy transfer $\int_1^2 \frac{dQ}{T}$. The

difference is produced internally due to irreversibility. The amount of entropy generation S_{gen} is given by

$$S_2 - S_1 - \int_1^2 \frac{dQ}{T} = S_{\text{gen}} \quad (7.28)$$

Entropy change Entropy transfer Entropy production

$$\therefore S_{\text{gen}} \geq 0$$

The second law states that, in general, *any thermodynamic process is accompanied by entropy generation.*

Process 1–2, which does not generate any entropy ($S_{\text{gen}} = 0$), is a reversible process (Fig. 7.25). Paths for which $S_{\text{gen}} > 0$ are considered irreversible. Like heat transfer and work transfer during the process 1–2, the entropy generation also depends on the path the system follows. S_{gen} is, therefore, not a thermodynamic property and dS_{gen} is an inexact differential, although $(S_2 - S_1)$ depends only on the end states. In the differential form, Eq. (7.28) can be written as

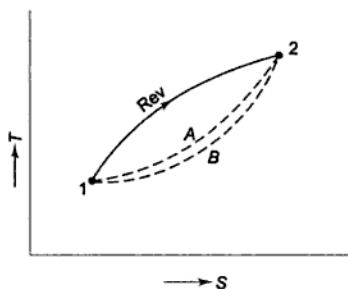

Fig. 7.25 Entropy generation depends on the path

$$dS_{\text{gen}} = dS - \frac{\delta Q}{T} \quad (7.29)$$

The amount of entropy generation quantifies the intrinsic irreversibility of the process. If the path *A* causes more entropy generation than path *B* (Fig. 7.25), i.e.

$$(S_{\text{gen}})_A > (S_{\text{gen}})_B$$

the path *A* is more irreversible than path *B* and involves more 'lost work'.

If heat transfer occurs at several locations on the boundary of a system, the entropy transfer term can be expressed as a sum, so Eq. (7.28) takes the form

$$S_2 - S_1 = \sum_j \frac{Q_j}{T_j} + S_{\text{gen}} \quad (7.30)$$

where Q_j/T_j is the amount of entropy transferred through the portion of the boundary at temperature T_j .

On a time rate basis, the entropy balance can be written as

$$\frac{dS}{d\tau} = \sum_j \frac{\dot{Q}_j}{T_j} + \dot{S}_{\text{gen}} \quad (7.31)$$

where $dS/d\tau$ is the rate of change of entropy of the system, \dot{Q}_j/T_j is the rate of entropy transfer through the portion of the boundary whose instantaneous temperature is T_j , and \dot{S}_{gen} is the rate of entropy generation due to irreversibilities within the system.

7.12 Entropy Generation in an Open System

In an open system, there is transfer of three quantities: mass, energy and entropy. The control surface can have one or more openings for mass transfer (Fig. 7.26). It is rigid, and there is shaft work transfer across it.

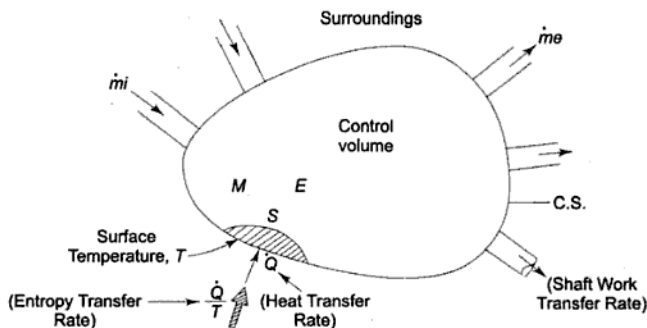

Fig. 7.26 Schematic of an open system and its interaction with surroundings

The continuity equation gives

$$\sum_i \dot{m}_i - \sum_e \dot{m}_e = \frac{\partial M}{\partial \tau} \quad (7.32)$$

net mass
rate of mass
transfer rate
accumulation

in the CV

The energy equation gives

$$\sum_i \dot{m}_i \left(h + \frac{V^2}{2} + gZ \right)_i - \sum_e \dot{m}_e \left(h + \frac{V^2}{2} + gZ \right)_e + \dot{Q} - \dot{W}_{sh} = \frac{\partial E}{\partial \tau} \quad (7.33)$$

net rate of energy
rate of energy
transfer
accumulation in the CV

The second law inequality or the entropy principle gives

$$\sum_i \dot{m}_i s_i - \sum_e \dot{m}_e s_e + \frac{\dot{Q}}{T} \leq \frac{\partial S}{\partial \tau} \quad (7.34)$$

net rate of entropy
rate of increase of
transfer
entropy of the CV

Here \dot{Q} represents the rate of heat transfer at the location of the boundary where the instantaneous temperature is T . The ratio \dot{Q}/T accounts for the entropy transfer along with heat. The terms $\dot{m}_i s_i$ and $\dot{m}_e s_e$ account, respectively, for rates of entropy transfer into and out of the CV accompanying mass flow. The rate of entropy increase of the control volume exceeds, or is equal to, the net

rate of entropy transfer into it. The difference is the entropy generated within the control volume due to irreversibility. Hence, the rate of entropy generation is given by

$$\dot{S}_{\text{gen}} = \frac{\partial S}{\partial \tau} - \sum_i \dot{m}_i s_i + \sum_e \dot{m}_e s_e - \frac{\dot{Q}}{T} \quad (7.35)$$

By the second law,

$$\dot{S}_{\text{gen}} \geq 0$$

If the process is reversible, $\dot{S}_{\text{gen}} = 0$. For an irreversible process, $\dot{S}_{\text{gen}} > 0$.

The magnitude of \dot{S}_{gen} quantifies the irreversibility of the process. If systems *A* and *B* operate so that $(\dot{S}_{\text{gen}})_A > (\dot{S}_{\text{gen}})_B$ it can be said that the system *A* operates more irreversibly than system *B*. The unit of \dot{S}_{gen} is W/K.

At steady state, the continuity equation gives

$$\sum_i \dot{m}_i = \sum_e \dot{m}_e \quad (7.36)$$

the energy equation becomes

$$0 = \dot{Q} - \dot{W}_{\text{sh}} + \sum_i \dot{m}_i \left(h + \frac{V^2}{2} + gZ \right)_i - \sum_e \dot{m}_e \left(h + \frac{V^2}{2} + gZ \right)_e \quad (7.37)$$

and the entropy equation reduces to

$$0 = \frac{\dot{Q}}{T} + \sum_i \dot{m}_i s_i - \sum_e \dot{m}_e s_e + \dot{S}_{\text{gen}} \quad (7.38)$$

These equations often must be solved simultaneously, together with appropriate property relations.

Mass and energy are conserved quantities, but entropy is not generally conserved. The rate at which entropy is transferred out must exceed the rate at which entropy enters the CV, the difference being the rate of entropy generated within the CV owing to irreversibilities.

For one-inlet and one-exit control volumes, the entropy equation becomes

$$0 = \frac{\dot{Q}}{T} + \dot{m}(s_1 - s_2) + \dot{S}_{\text{gen}}$$

$$\therefore s_2 - s_1 = \frac{1}{\dot{m}} \left(\frac{\dot{Q}}{T} \right) + \frac{\dot{S}_{\text{gen}}}{\dot{m}} \quad (7.39)$$

7.13 First and Second Laws Combined

By the second law

$$\delta Q_{\text{rev}} = T \, dS$$

and by the first law, for a closed non-flow system,

$$\delta Q = dU + p \, dV$$

$$T dS = dU + pdV \quad (7.40)$$

Again, the enthalpy

$$\begin{aligned} H &= U + pV \\ dH &= dU + pdV + Vdp \\ &= TdS + Vdp \\ TdS &= dH - Vdp \end{aligned} \quad (7.41)$$

Equations (7.40) and (7.41) are the thermodynamic equations relating the properties of the system.

Let us now examine the following equations as obtained from the first and second laws:

- $\delta Q = dE + \delta W$ —This equation holds good for any process, reversible or irreversible, and for any system.
- $\delta Q = dU + p\delta W$ —This equation holds good for any process undergone by a closed stationary system.
- $\delta Q = dU + p\delta V$ —This equation holds good for a closed system when only pdV -work is present. This is true only for a reversible (quasi-static) process.
- $\delta Q = TdS$ —This equation is true only for a reversible process.
- $TdS = dU + pdV$ —This equation holds good for any process reversible or irreversible, undergone by a closed system, since it is a relation among properties which are independent of the path.
- $TdS = dH - Vdp$ —This equation also relates only the properties of a system. There is no path function term in the equation. Hence the equation holds good for any process.

The use of the term 'irreversible process' is doubtful, since no irreversible path or process can be plotted on thermodynamic coordinates. It is more logical to state that 'the change of state is irreversible, rather than say 'it is an irreversible process'. A natural process which is inherently irreversible is indicated by a dotted line connecting the initial and final states, both of which are in equilibrium. The dotted line has no other meaning, since it can be drawn in any way. To determine the entropy change for a real process, a known reversible path is made to connect the two end states, and integration is performed on this path using either equation (e) or equation (f), as given above. Therefore, the entropy change of a system between two identifiable equilibrium states is the same whether the intervening process is reversible or the change of state is irreversible.

7.14 Reversible Adiabatic Work in a Steady Flow System

In the differential form, the steady flow energy equation per unit mass is given by Eq. (5.11),

$$\delta Q = dh + VdV + gdZ + \delta W_x$$

For a reversible process, $\delta Q = Tds$

$$\therefore Tds = dh + VdV + gdZ + \delta W_x \quad (7.42)$$

Using the property relation, Eq. (7.41), per unit mass,

$$Tds = dh - vdp$$

in Eq. (7.42), we have

$$-vdp = VdV + gdZ + \delta W_x \quad (7.43)$$

On intergration

$$-\int_1^2 vdp = \Delta \frac{V^2}{2} + W_x \quad (7.44)$$

If the changes in K.E and P.E. are neglected, Eq. (7.44) reduces to

$$W_x = -\int_1^2 vdp \quad (7.45)$$

If $\delta Q = 0$, implying $ds = 0$, the property relation gives

$$dh = vdp$$

$$\text{or} \quad h_2 - h_1 = \int_1^2 vdp \quad (7.46)$$

From Eqs (7.45) and (7.46),

$$W_x = h_1 - h_2 = -\int_1^2 vdp \quad (7.47)$$

The integral $-\int_1^2 vdp$ represents an area on the p - v plane (Fig. 7.27). To make the integration, one must have a relation between p and v such as $pv^n = \text{constant}$.

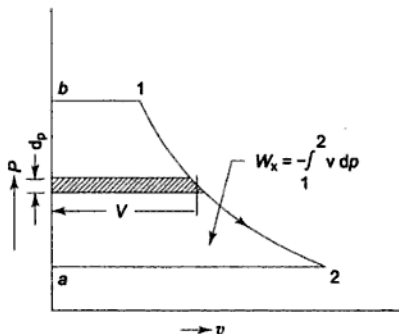

Fig. 7.27 Reversible steady flow work interaction

$$\begin{aligned} \therefore W_{1-2} &= h_1 - h_2 = - \int_1^2 v dp \\ &= \text{area } 12ab1 \end{aligned}$$

Equation (7.47) holds good for a steady flow work-producing machine like an engine or turbine as well as for a work-absorbing machine like a pump or a compressor, when the fluid undergoes reversible adiabatic expansion or compression.

It may be noted that for a closed stationary system like a gas confined in a piston-cylinder machine (Fig. 7.28a), the reversible work done would be

$$W_{1-2} = \int_1^2 p dV = \text{Area } 12cd1$$

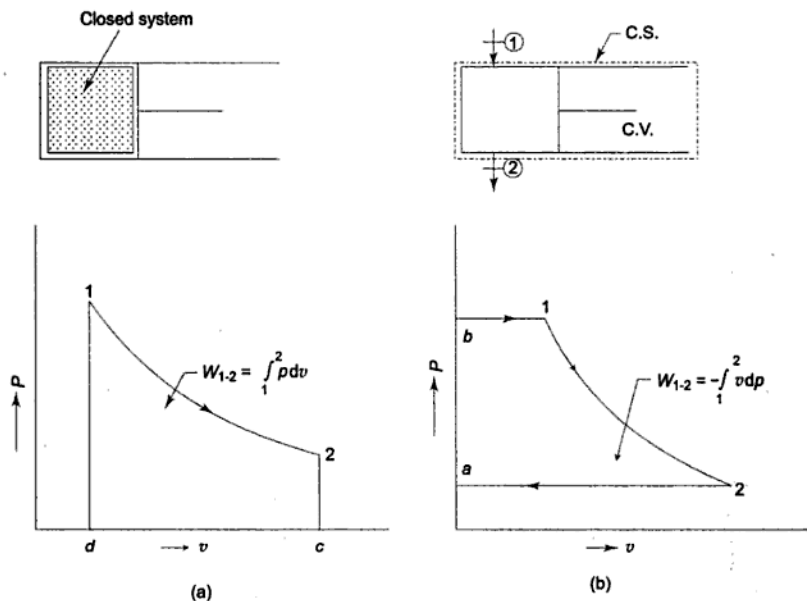

Fig. 7.28 Reversible work transfer in (a) a closed system and (b) a steady flow system

The reversible work done by a steady flow system (Fig. 7.28b) would be

$$W_{1-2} = - \int_1^2 v dp = \text{Area } 12ab1$$

7.15 Entropy and Direction: The Second Law—A Directional Law of Nature

Since the entropy of an isolated system can never decrease, it follows that only those processes are possible in nature which would give an entropy increase for the system and the surroundings together (the universe). All spontaneous processes in nature occur only in one direction from a higher to a lower potential, and these are accompanied by an entropy increase of the universe. When the potential gradient is infinitesimal (or zero in the limit), the entropy change of the universe is zero, and the process is reversible. The second law indicates the direction in which a process takes place. *A process always occurs in such a direction as to cause an increase in the entropy of the universe.* The macroscopic change ceases only when the potential gradient disappears and the equilibrium is reached when the entropy of the universe assumes a maximum value. To determine the equilibrium state of an isolated system it is necessary to express the entropy as a function of certain properties of the system and then render the function a maximum. At equilibrium, the system (isolated) exists at the peak of the entropy-hill, and $dS = 0$ (Fig. 7.13).

The natural direction of events in which entropy increases indicates the 'arrow of time' which results from the universe not being in thermodynamic equilibrium. It undergoes a *natural evolution* and inexorably approaches the state of equilibrium.

7.16 Entropy and disorder

Work is a macroscopic concept. Work involves order or the orderly motion of molecules, as in the expansion or compression of a gas. The kinetic energy and potential energy of a system represent orderly forms of energy. The kinetic energy of a gas is due to the coordinated motion of all the molecules with the same average velocity in the same direction. The potential energy is due to the vantage position taken by the molecules or displacements of molecules from their normal positions. Heat or thermal energy is due to the random thermal motion of molecules in a completely disorderly fashion and the average velocity is zero. Orderly energy can be readily converted into disorderly energy, e.g., mechanical and electrical energies into internal energy (and then heat) by friction and Joule effect. Orderly energy can also be converted into one another. *But there are natural limitations on the conversion of disorderly energy into orderly energy, as delineated by the second law.* When work is dissipated into internal energy, the disorderly motion of molecules is increased. Two gases, when mixed, represent a higher degree of disorder than when they are separated. An irreversible process always tends to take the system (isolated) to a state of greater disorder. It is a tendency on the part of nature to proceed to a state of greater disorder. An isolated system always tends to a state of greater entropy. So there is a close link between entropy and disorder. It may be stated roughly

that the entropy of a system is a measure of the degree of molecular disorder existing in the system. When heat is imparted to a system, the disorderly motion of molecules increases, and so the entropy of the system increases. The reverse occurs when heat is removed from the system.

Ludwig Boltzmann (1877) introduced statistical concepts to define disorder by attaching to each state a *thermodynamic probability*, expressed by the quantity W , which is greater the more disordered the state is. The increase of entropy implies that the system proceeds by itself from one state to another with a higher thermodynamic probability (or disorder number). An irreversible process goes on until the *most probable state* (equilibrium state when W is maximum) corresponding to the maximum value of entropy is reached. Boltzmann assumed a functional relation between S and W . While entropy is additive, probability is multiplicative. If the two parts A and B of a system in equilibrium are considered, the entropy is the sum

$$S = S_A + S_B$$

and the thermodynamic probability is the product

$$W = W_A \cdot W_B$$

Again,

$$S = S(W), S_A = S(W_A), \text{ and } S_B = S(W_B)$$

\therefore

$$S(W) = S(W_A W_B) = S(W_A) + S(W_B)$$

which is a well-known functional equation for the logarithm. Thus the famous relation is reached

$$S = K \ln W \quad (7.48)$$

where K is a constant, known as Boltzmann constant. This is engraved upon Boltzmann's tombstone in Vienna.

When $W = 1$, which represents the greatest order, $S = 0$. This occurs only at $T = 0\text{K}$. This state cannot be reached in a finite number of operations. This is the Nernst-Simon statement of third law of thermodynamics. In the case of a gas, W increases due to an increase in volume V or temperature T . In the reversible adiabatic expansion of a gas the increase in disorder due to an increase in volume is just compensated by the decrease in disorder due to a decrease in temperature, so that the disorder number or entropy remains constant.

7.17 Absolute Entropy

It is important to note that one is interested only in the amount by which the entropy of the system changes in going from an initial to a final state, and not in the value of absolute entropy. In cases where it is necessary, a zero value of entropy of the system at an arbitrarily chosen standard state is assigned, and the entropy changes are calculated with reference to this standard state.

7.18 Entropy and Information Theory

The starting point of information theory is the concept of *uncertainty*. Let us define an event as an occurrence which can result in one of the many possible

outcomes. The outcome of the event is known only after it has occurred, and before its occurrence we do not know which one of the several possible outcomes will actually result. We are thus uncertain with regard to the outcome before the occurrence of the event. After the event has occurred, we are no longer uncertain about it. If we know or can assign a *probability* to each one of the outcomes, then we will have some information as to which one of the outcomes is most likely to occur.

For example, let us consider the throwing of a dice and try to guess the result. Each event of turning 1, 2, 3, 4, 5 and 6 has a probability of $1/6$. If it is told that the result is odd, the probability of a correct guess is $1/3$. If it is told further that the number is not a 3, the probability of the correct guess becomes $1/2$. It is thus seen that *the smaller the probability, greater is the uncertainty*.

The amount of information conveyed by a message increases as the amount of uncertainty regarding the message becomes greater. The more it is known about the message a source will produce, the less the uncertainty, and less the information conveyed. *The entropy of communication theory is a measure of this uncertainty conveyed by a message from a source.*

As stated earlier, in information theory a value of uncertainty is associated with each outcome of an event. Let us denote the uncertainty about an outcome whose probability is p . The knowledge of this uncertainty depends on certain characteristics given below:

1. The uncertainty u about an event A with possible outcomes N_1, N_2, \dots depends upon the probabilities p_1, p_2, \dots of these outcomes, or:

$$u = f(p_1, p_2, \dots)$$

If p_i is the probability of the i -th outcome:

$$u = f(p_i)$$

2. The uncertainty u is a monotonic function of the probability of the outcome p and it decreases with increasing probability, or:

$$du/dp < 0$$

3. When the probability $p = 1$, the uncertainty $u = 0$.
4. The uncertainty about two independent events A and B taken together as one should be the sum of the uncertainties about A and B taken separately,

$$u(A, B) = u_A + u_B$$

In other words, *uncertainty is an additive property*. In the case of probabilities, however,

$$p(A, B) = p_A \cdot p_B$$

The functional relationship between u and p can be derived, as in Eq. (7.48),

$$u = -K \ln p = K \ln \frac{1}{p} \quad (7.49)$$

where K is a constant. Since p is always less than 1, u is always positive.

5. If the event has a very large number of outcomes, an average value of uncertainty for the outcomes of the event is significant.

If p_1, p_2, p_3, \dots be the probabilities of the outcomes of an event with uncertainties u_1, u_2, u_3, \dots , then the average value of the uncertainty for the event as a whole is given by the *expectation value of the uncertainty* $\langle u \rangle$, which is written as:

$$\langle u \rangle = \sum_i p_i u_i$$

Since p_i 's are probabilities,

$$\sum_i p_i = 1$$

Again, since $u_i = -K \ln p_i$,

$$\text{therefore, } \langle u \rangle = \sum_i p_i u_i = -K \sum_i p_i \ln p_i \quad (7.50)$$

The measure of uncertainty can be used to define the amount of information contained in a message. The information in a message has the effect of reducing or eliminating uncertainties. We, therefore, define the *information I in a message as the decrease in uncertainty* as a result of receiving the message, or

$$I = u_1 - u_2 \quad (7.51)$$

where u_1 and u_2 are the uncertainties before and after receiving the message respectively about the outcome with which the message is concerned. Using Eq. (7.49),

$$I = K \ln \frac{p_2}{p_1} \quad (7.52)$$

where p_1 and p_2 are the probabilities before and after receiving the message respectively.

If the message removes the uncertainty completely giving complete information about the outcome, $u_2 = 0$ and $I = u_1$. In general, *information is equal to the uncertainty*. When we are dealing with many outcomes with their associated uncertainties, we can define the average or expected value of the information,

$$\langle I \rangle = \langle u \rangle = -K \sum_i p_i \ln p_i \quad (7.53)$$

The expected value of information is also called entropy in information theory and is designated by the symbol S , so that

$$S = -K \sum_i p_i \ln p_i \quad (7.54)$$

This is known as *Shannon's formula*.

7.18.1 Statistical Formalism

Let V_1, V_2, \dots, V_c are the values of the various outcomes, and p_1, p_2, \dots, p_c are the probabilities associated. Let \bar{V} is known as the average value of all the outcomes, which is the same as the expected value. The equations of constraint are:

$$\begin{aligned}\Sigma p_i &= 1 \\ \Sigma p_i v_i &= \langle V \rangle = \bar{V}\end{aligned}\quad (7.55)$$

If p_i 's are given, then \bar{V} can be estimated from the above equation. But if V is given and p_i 's are required, then we have c unknowns, viz., p_1, p_2, \dots, p_c , and only two equations. If $c > 2$, the problem is indeterminate. If one set of p_i 's is chosen arbitrarily, some outcomes are certainly overemphasized. The problem is then how to avoid *bias* in selecting a certain set of p_i 's. The answer according to E.T. Jaynes is to assign that set of values of p_i 's which is consistent with the given information and which maximizes the uncertainty. This is *the principle of minimum prejudice*, enunciated by Jaynes in the following words:

"The least prejudiced or most unbiased estimate of probabilities is that assignment which maximizes the entropy S , subject to the given information".

The entropy S represents the uncertainty of an event, which is to be maximized:

$$S = -K \Sigma p_i \ln p_i \quad (7.54)$$

subject to the two constraints of Eq. (7.55). Lagrange's method of undetermined multipliers (see Chap. 21) will be used for the solution. Differentiating Eqs (7.54) and (7.55)

$$\Sigma dp_i = 0 \quad (7.56)$$

$$\Sigma V_i dp_i = 0 \quad (7.57)$$

$$dS = -K [\Sigma \ln p_i dp_i + \Sigma dp_i] = 0$$

or, $\Sigma \ln p_i dp_i = 0 \quad (7.58)$

where \bar{V}_i 's are held constant and $dS = 0$ for S to be maximum. Multiplying Eq. (7.56) by λ and Eq. (7.57) by β and adding to Eq. (7.58).

$$\Sigma [\ln p_i + \lambda + \beta V_i] dp_i = 0 \quad (7.59)$$

where λ and β are the Lagrange's multipliers. Since dp_i 's are non-zero,

$$\begin{aligned}\ln p_i + \lambda + \beta V_i &= 0 \\ \text{or } p_i &= e^{-\lambda} e^{-\beta V_i}\end{aligned}\quad (7.60)$$

The Eq. (7.60) represents a set of c equations:

$$\begin{aligned}p_1 &= e^{-\lambda} e^{-\beta V_1} \\ p_2 &= e^{-\lambda} e^{-\beta V_2} \\ &\dots \dots \dots \\ p_c &= e^{-\lambda} e^{-\beta V_c}\end{aligned}\quad (7.61)$$

The above equations are *the desired unbiased set of p_i 's*.

Again,

$$\sum p_i = \sum_{i=1}^c e^{-\lambda} e^{-\beta V_i} = 1$$

$$e^{-\lambda} = \frac{1}{\sum e^{-\beta V_i}}$$

or
$$\lambda = \ln \sum e^{-\beta V_i} \quad (7.62)$$

From Eq. (7.60),

$$p_i = \frac{e^{-\beta V_i}}{\sum e^{-\beta V_i}} \quad (7.63)$$

Thus, λ has been estimated. Using Eq. (7.55)

$$\sum_i p_i V_i = \frac{\sum V_i e^{-\beta V_i}}{\sum e^{-\beta V_i}} = \bar{V} \quad (7.64)$$

Since \bar{V} is known, β can be determined. The entropy can be expressed in terms of λ and β as:

$$\begin{aligned} S &= -K \sum p_i [-\lambda - \beta V_i] \\ &= K\lambda \sum p_i + K\beta \sum p_i V_i \\ S &= K\lambda + K\beta \langle V \rangle \end{aligned} \quad (7.65)$$

The above procedure is referred to as the *Jaynes' formalism*.

7.18.2 Information Theory Applied to a System of Particles

Let us consider a system having a large number of particles. According to the quantum theory (see Chap. 19), the energy that the system can have is discretely distributed. The system cannot have any energy, but only certain values of energy levels. Let us denote by p_i the probability of the energy level ϵ_i . A high probability signifies that the corresponding energy level is more frequently attained by the system, i.e., the system can be found for longer durations of time in that energy level. The problem is to determine the most probable state of the system subject to the constraints imposed by the nature of the system. Usually, the average energy of the system, which is also the expectation energy $\langle E \rangle$ is known by physical measurements.

Therefore,

$$\langle E \rangle = \sum p_i \epsilon_i = \bar{E}$$

and

$$\sum p_i = 1$$

In statistical thermodynamics, one proceeds to determine the number of microstates corresponding to the most probable macrostate of the system (see Chap. 19), corresponding to the thermodynamic equilibrium state when W is maximized to yield $S = K \ln W$. The entropy signifies the uncertainty inherent in the system.

Jaynes' formalism can be applied here. The outcomes are the various possible energy levels corresponding to the various macrostates of the system. The probabilities p_i of the energy levels are to be determined according to the principle of minimum prejudice, subject to the constraints,

$$\begin{aligned}\Sigma p_i &= 1 \\ \Sigma p_i \varepsilon_i &= \langle E \rangle\end{aligned}$$

Maximizing the uncertainty or the entropy:

$$S = -K \Sigma p_i \ln p_i$$

we get the probability distribution, as obtained earlier in Eq. (7.60)

$$p_i = e^{-\lambda} e^{-\beta \varepsilon_i} \quad (7.66)$$

where $e^\lambda = \Sigma e^{-\beta \varepsilon_i}$ which is the *partition function* (z) of the system (as explained in Chap. 19). The maximum value of the entropy is then (as in Eq. 7.65),

$$S = K\lambda + k\beta \langle E \rangle \quad (7.67)$$

By considering the ideal distribution of an ideal gas, we can identify β as $1/KT$ (Chap. 19), where K is the Boltzmann constant. Thus, the probability distribution of energy levels is temperature dependent (Eq. 7.66).

7.18.3 Information Theory and Classical Thermodynamics

Classical thermodynamics usually treats the concepts of heat and work as primitive. The information theory, however, considers heat and work as derived quantities. The expectation energy is given by:

$$\langle E \rangle = \Sigma p_i \varepsilon_i$$

Differentiating,

$$d\langle E \rangle = \Sigma \varepsilon_i dp_i + \Sigma p_i d\varepsilon_i \quad (7.68)$$

Thus, the observable energy of the system can be changed by changing either the probabilities, p_i , or the permissible states, ε_i or both.

The entropy $S = -K \Sigma p_i \ln p_i$

shows that a change in the system's energy of the p_i -type will change the entropy as well, the change in the energy of the ε_i -type not affecting the entropy.

Let us consider changes of the ε_i -type. If a force F_i acts on a system at the quantum state i and produces a small displacement dx , the internal energy of the system changes by $d\varepsilon_i$, so that

$$F_i = \frac{\partial \varepsilon_i}{\partial x}$$

If the probability that the system is in state i is p_i , the expectation force is:

$$\langle F \rangle = \Sigma p_i F_i$$

Therefore, $\langle F \rangle = - \Sigma p_i \frac{\partial \varepsilon_i}{\partial x}$ (7.69)

By analogy for a fluid, the pressure is:

$$p = -\sum p_i \frac{\partial \epsilon_i}{\partial V} \quad (7.70)$$

Work done in a reversible process:

$$\delta W_r = p \, dV$$

From Eq. (7.70),

$$\delta W_r = -\sum p_i \, d\epsilon_i \quad (7.71)$$

Thus, *the reversible work does not produce any change in the entropy of the system.*

From Eqs (7.68) and (7.71)

$$d\langle E \rangle = \sum \epsilon_i \, dp_i - \delta W_r$$

or $\delta Q - \delta W = \sum \epsilon_i \, dp_i - \delta W_r$

or $\delta Q + (\delta W_r - \delta W) = \sum \epsilon_i \, dp_i \quad (7.72)$

Thus, *the heat transferred, dQ , and the lost work, $(\delta W_r - \delta W)$ are responsible for changes in p_i , and therefore, the entropy of the system.* It is shown that entropy of a system changes due to external interaction by heat transfer ($d_e s$) and due to internal dissipative effect ($d_i s$). In absence of any dissipative effect,

$$\delta Q_r = \sum \epsilon_i \, dp_i \quad (7.73)$$

Substituting $p_i = e^{-\lambda} e^{-\beta \epsilon_i}$ in Eq. (7.69),

$$\langle F \rangle = -\sum e^{-\lambda} e^{-\beta \epsilon_i} \frac{\partial \epsilon_i}{\partial x}$$

Again, since $\frac{\partial}{\partial x} [e^{-\beta \epsilon_i}] = -\beta e^{-\beta \epsilon_i} \frac{\partial \epsilon_i}{\partial x}$

Therefore,

$$\langle F \rangle = \frac{e^{-\lambda}}{\beta} \sum \frac{\partial e^{-\beta \epsilon_i}}{\partial x}$$

Now, $e^{\lambda} = \sum e^{-\beta \epsilon_i}$

$$\begin{aligned} \langle F \rangle &= \frac{1}{\beta \sum e^{-\beta \epsilon_i}} \frac{\partial \sum e^{-\beta \epsilon_i}}{\partial x} \\ &= \frac{1}{\beta} \frac{\partial}{\partial x} [\ln \sum e^{-\beta \epsilon_i}] = \frac{1}{\beta} \frac{\partial \lambda}{\partial x} \end{aligned}$$

By analogy for a fluid, the pressure is:

$$p = \frac{1}{\beta} \frac{\partial \lambda}{\partial V} \quad (7.74)$$

It is noted that λ depends on β as well as ε , and hence on volume V .

$$\begin{aligned} \text{Now, } S &= K\lambda + K\beta \langle E \rangle \\ dS &= Kd\lambda + K\langle E \rangle d\beta + K\beta d\langle E \rangle \\ &= K \left[\left(\frac{\partial \lambda}{\partial \beta} \right)_V d\beta + \left(\frac{\partial \lambda}{\partial V} \right)_\beta dV \right] + K\langle E \rangle d\beta + K\beta d\langle E \rangle \end{aligned}$$

$$\begin{aligned} \text{Now, } \langle E \rangle &= \sum p_i \varepsilon_i = \frac{\sum e^{-\beta \varepsilon_i} \varepsilon_i}{\sum e^{-\beta \varepsilon_i}} \\ &= - \left[\frac{\partial \lambda}{\partial \beta} \right]_V \end{aligned}$$

Therefore,

$$\begin{aligned} dS &= K \left[\frac{\partial \lambda}{\partial \beta} \right]_V d\beta + \left[\frac{\partial \lambda}{\partial V} \right]_\beta dV \\ &\quad - K \left[\frac{\partial \lambda}{\partial \beta} \right]_V d\beta + K\beta d\langle E \rangle \\ &= K\beta p dV + K\beta d\langle E \rangle \end{aligned} \quad [\text{From Eq. 7.74}]$$

$$\text{Since } \beta = \frac{1}{KT}$$

$$dS = \frac{pdV}{T} + \frac{dE}{T}$$

$$\text{or, } TdS = dE + pdV \quad (7.75)$$

which is a well-known equation of classical thermodynamics. For a reversible process,

$$\delta W_r = pdV$$

and from first law,

$$\delta Q = dE + \delta W$$

$$\delta Q_r = dE + pdV \quad (7.76)$$

From Eqs (7.75) and (7.76),

$$dS = \frac{\delta Q_r}{T} \quad (7.77)$$

This is in conformity with the classical formula for entropy. However, *the entropy is a fundamental concept in information theory and not a derived function as in classical thermodynamics.*

7.19 Postulatory Thermodynamics

The property 'entropy' plays the central role in thermodynamics. In the *classical approach*, as followed in this book, entropy is introduced via the

concept of the heat engine. It follows the way in which the subject of thermodynamics developed historically mainly through the contributions of Sadi Carnot, James Prescott Joule, William Thomson (Lord Kelvin), Rudolf Clausius, Max Planck and Josiah Willard Gibbs.

In the *postulatory approach*, as developed by H.B Callen (see Reference), entropy is introduced at the beginning. The development of the subject has been based on four postulates. Postulate I defines the equilibrium state. Postulate II introduces the property 'entropy' which is rendered maximum at the final equilibrium state. Postulate III refers to the additive nature of entropy which is a monotonically increasing function of energy. Postulate IV mentions that the entropy of any system vanishes at the absolute zero of temperature. With the help of these postulates the conditions of equilibrium under different constraints have been developed.

SOLVED EXAMPLES

Example 7.1 Water flows through a turbine in which friction causes the water temperature to rise from 35°C to 37°C. If there is no heat transfer, how much does the entropy of the water change in passing through the turbine? (Water is incompressible and the process can be taken to be a constant volume.)

Solution The presence of friction makes the process irreversible and causes an entropy increase for the system. The flow process is indicated by the dotted line joining the equilibrium states 1 and 2 (Fig. Ex. 7.1). Since entropy is a state property and the entropy change depends only on the two end states and is independent of the path the system follows, to find the entropy change, the irreversible path has to be replaced by a reversible path, as shown in the figure, because no integration can be made on a path other than a reversible path.

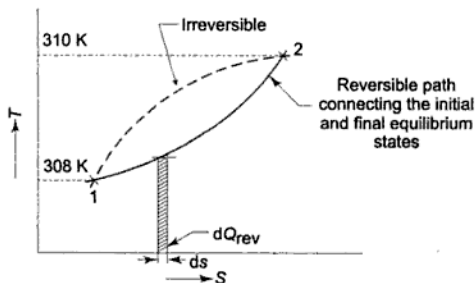

Fig. Ex. 7.1

$$T_2 = 37 + 273 = 310 \text{ K}$$

$$T_1 = 35 + 273 = 308 \text{ K}$$

We have

$$\begin{aligned} \delta Q_{\text{rev}} &= TdS \\ dS &= \frac{mc_v dT}{T} \\ S_2 - S_1 &= mc_v \ln \frac{T_2}{T_1} \\ &= 1 \times 4.187 \ln \frac{310}{308} \\ &= 0.0243 \text{ kJ/K} \end{aligned}$$

Ans.

Example 7.2 (a) One kg of water at 273 K is brought into contact with a heat reservoir at 373 K. When the water has reached 373 K, find the entropy change of the water, of the heat reservoir, and of the universe.

(b) If water is heated from 273 K to 373 K by first bringing it in contact with a reservoir at 323 K and then with a reservoir at 373 K, what will the entropy change of the universe be?

(c) Explain how water might be heated from 273 K to 373 K with almost no change in the entropy of the universe.

Solution (a) Water is being heated through a finite temperature difference (Fig. Ex. 7.2). The entropy of water would increase and that of the reservoir would decrease so that the net entropy change of the water (system) and the reservoir together would be positive definite. Water is being heated irreversibly, and to find the entropy change of water, we have to assume a reversible path between the end states which are at equilibrium.

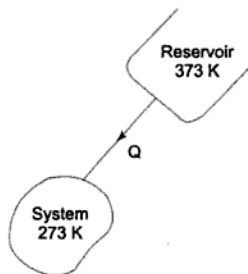

Fig. Ex. 7.2

$$\begin{aligned} (\Delta S)_{\text{water}} &= \int \frac{dQ}{T} = \int_{T_1}^{T_2} \frac{m c dT}{T} = mc \ln \frac{T_2}{T_1} \\ &= 1 \times 4.187 \ln \frac{373}{273} = 1.305 \text{ kJ/K} \end{aligned}$$

The reservoir temperature remains constant irrespective of the amount of heat withdrawn from it.

Amount of heat absorbed by the system from the reservoir,

$$Q = 1 \times 4.187 \times (373 - 273) = 418.7 \text{ kJ}$$

\therefore Entropy change of the reservoir

$$(\Delta S)_{\text{res}} = -\frac{Q}{T} = -\frac{418.7}{373} = -1.122 \text{ kJ/K}$$

\therefore Entropy change of the universe

$$\begin{aligned} (\Delta S)_{\text{univ}} &= (ds)_{\text{system}} + (\Delta S)_{\text{res}} \\ &= 1.305 - 1.122 = 0.183 \text{ kJ/K} \end{aligned} \quad \text{Ans.(a)}$$

(b) Water is being heated in two stages, first from 273 K to 323 K by bringing it in contact with a reservoir at 323 K, and then from 323 K to 373 K by bringing it in contact of a second reservoir at 373 K.

$$\begin{aligned} (\Delta S)_{\text{water}} &= \int_{273 \text{ K}}^{323 \text{ K}} mc \frac{dT}{T} + \int_{323 \text{ K}}^{373 \text{ K}} mc \frac{dT}{T} \\ &= 4.187 \left(\ln \frac{323}{273} + \ln \frac{373}{323} \right) = (0.1673 + 0.1441) 4.187 \\ &= 1.305 \text{ kJ/K} \end{aligned}$$

$$(\Delta S)_{\text{res I}} = -\frac{1 \times 4.187 \times (323 - 273)}{323} = -0.647 \text{ kJ/K}$$

$$(\Delta S)_{\text{res II}} = -\frac{1 \times 4.187 \times (373 - 323)}{373} = -0.56 \text{ kJ/K}$$

$$\begin{aligned} \therefore (\Delta S)_{\text{univ}} &= (\Delta S)_{\text{water}} + (\Delta S)_{\text{res I}} + (\Delta S)_{\text{res II}} \\ &= 1.305 - 0.647 - 0.56 \\ &= 0.098 \text{ kJ/K} \end{aligned} \quad \text{Ans.(b)}$$

(c) The entropy change of the universe would be less and less if the water is heated in more and more stages, by bringing the water in contact successively with more and more heat reservoirs, each succeeding reservoir being at a higher temperature than the preceding one.

When water is heated in infinite steps, by bringing it in contact with an infinite number of reservoirs in succession, so that at any instant the temperature difference between the water and the reservoir in contact is infinitesimally small, then the net entropy change of the universe would be zero, and the water would be *reversibly* heated.

Example 7.3 One kg of ice at -5°C is exposed to the atmosphere which is at 20°C . The ice melts and comes into thermal equilibrium with the atmosphere.

(a) Determine the entropy increase of the universe. (b) What is the minimum amount of work necessary to convert the water back into ice at -5°C ? c_p of ice is 2.093 kJ/kg K and the latent heat of fusion of ice is 333.3 kJ/kg .

Solution Heat absorbed by ice Q from the atmosphere (Fig. Ex. 7.3.1)

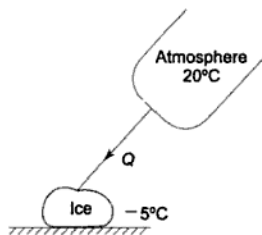

Fig. Ex. 7.3.1

$$\begin{aligned}
 &= \text{Heat absorbed in solid phase} + \text{Latent heat} \\
 &\quad + \text{Heat absorbed in liquid phase} \\
 &= 1 \times 2.093 \times [0 - (-5)] + 1 \times 333.3 + 1 \times 4.187 \times (20 - 0) \\
 &= 427.5 \text{ kJ}
 \end{aligned}$$

Entropy change of the atmosphere.

$$(\Delta S)_{\text{atm}} = -\frac{Q}{T} = -\frac{427.5}{293} = -1.46 \text{ kJ/K}$$

Entropy change of the system (ice) as it gets heated from -5°C to 0°C

$$\begin{aligned}
 (\Delta S_{\text{I}})_{\text{system}} &= \int_{268}^{273} mc_p \frac{dT}{T} = 1 \times 2.093 \ln \frac{273}{268} = 2.093 \times 0.0186 \\
 &= 0.0389 \text{ kJ/K}
 \end{aligned}$$

Entropy change of the system as ice melts at 0°C to become water at 0°C

$$(\Delta S_{\text{II}})_{\text{system}} = \frac{333.3}{273} = 1.22 \text{ kJ/K}$$

Entropy change of water as it gets heated from 0°C to 20°C

$$(\Delta S_{\text{III}})_{\text{system}} = \int_{273}^{293} mc_p \frac{dT}{T} = 1 \times 4.187 \ln \frac{293}{273} = 0.296 \text{ kJ/K}$$

Total entropy change of ice as it melts into water

$$\begin{aligned}
 (\Delta S)_{\text{total}} &= \Delta S_{\text{I}} + \Delta S_{\text{II}} + \Delta S_{\text{III}} \\
 &= 0.0389 + 1.22 + 0.296 \\
 &= 1.5549 \text{ kJ/K}
 \end{aligned}$$

The entropy-temperature diagram for the system as ice at -5°C converts to water at 20°C is shown in Fig. Ex. 7.3.2

\therefore Entropy increase of the universe

$$\begin{aligned}
 (\Delta S)_{\text{univ}} &= (\Delta S)_{\text{system}} + (\Delta S)_{\text{atm}} \\
 &= 1.5549 - 1.46 = 0.0949 \text{ kJ/K}
 \end{aligned}$$

Ans. (a)

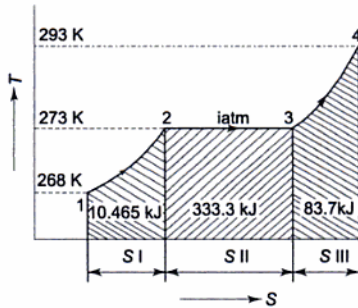

Fig. Ex. 7.3.2

(b) To convert 1 kg of water at 20°C to ice at -5°C, 427.5 kJ of heat have to be removed from it, and the system has to be brought from state 4 to state 1 (Fig. Ex. 7.3.2). A refrigerator cycle, as shown in Fig. Ex. 7.3.3, is assumed to accomplish this.

The entropy change of the system would be the same, i.e. $S_4 - S_1$, with the only difference that its sign will be negative, because heat is removed from the system (Fig. Ex. 7.3.2).

$$(\Delta S)_{\text{system}} = S_1 - S_4 \quad (\text{negative})$$

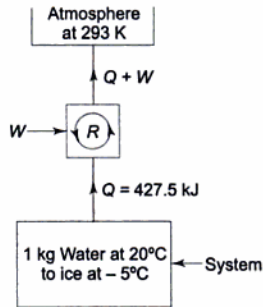

Fig. Ex. 7.3.3

The entropy change of the working fluid in the refrigerator would be zero, since it is operating in a cycle, i.e.,

$$(\Delta S)_{\text{ref}} = 0$$

The entropy change of the atmosphere (positive)

$$(\Delta S)_{\text{atm}} = \frac{Q + W}{T}$$

∴ Entropy change of the universe

$$\begin{aligned} (\Delta S)_{\text{univ}} &= (\Delta S)_{\text{system}} + (\Delta S)_{\text{ref}} + (\Delta S)_{\text{atm}} \\ &= (S_1 - S_4) + \frac{Q + W}{T} \end{aligned}$$

By the principle of increase of entropy

$$(\Delta S)_{\text{univ or isolated system}} \geq 0$$

$$\therefore \left[(S_1 - S_4) + \frac{Q + W}{T} \right] \geq 0$$

$$\therefore \frac{Q + W}{T} \geq (S_4 - S_1)$$

$$W \geq T(S_4 - S_1) - Q$$

$$\therefore W_{(\min)} = T(S_4 - S_1) - Q$$

$$\text{Here } Q = 427.5 \text{ kJ}$$

$$T = 293 \text{ K}$$

$$S_4 - S_1 = 1.5549 \text{ kJ/K}$$

$$\therefore W_{(\min)} = 293 \times 1.5549 - 427.5$$

$$= 28.5 \text{ kJ}$$

Ans. (b)

Example 7.4 Two identical bodies of constant heat capacity are at the same initial temperature T_i . A refrigerator operates between these two bodies until one body is cooled to temperature T_2 . If the bodies remain at constant pressure and undergo no change of phase, show that the minimum amount of work needed to do this is

$$W_{(\min)} = C_p \left(\frac{T_i^2}{T_2} + T_2 - 2T_i \right)$$

Solution Both the finite bodies A and B are initially at the same temperature T_i . Body A is to be cooled to temperature T_2 by operating the refrigerator cycle, as shown in Fig. Ex. 7.4. Let T_2' be the final temperature of body B .

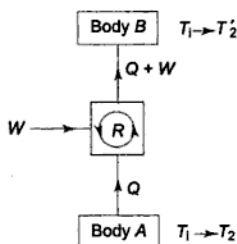

Fig. Ex. 7.4

Heat removed from body A to cool it from T_i to T_2

$$Q = C_p (T_i - T_2)$$

where C_p is the constant pressure heat capacity of the identical bodies A and B .

Heat discharged to body B

$$= Q + W = C_p (T_2' - T_i)$$

Work input, W

$$= C_p (T_2' - T_i) - C_p (T_i - T_2)$$

$$= C_p (T_2' + T_2 - 2T_i)$$

(7.4.1)

Now, the entropy change of body A

$$\Delta S_A = \int_{T_i}^{T_2} C_p \frac{dT}{T} = C_p \ln \frac{T_2}{T_i} \text{ (negative)}$$

The entropy change of body B

$$\Delta S_B = \int_{T_i}^{T_2'} C_p \frac{dT}{T} = C_p \ln \frac{T_2'}{T_i} \text{ (positive)}$$

Entropy change (cycle) of refrigerant = 0

\therefore Entropy change of the universe

$$\begin{aligned} (\Delta S)_{\text{univ}} &= \Delta S_A + \Delta S_B \\ &= C_p \ln \frac{T_2}{T_i} + C_p \ln \frac{T_2'}{T_i} \end{aligned}$$

By the entropy principle

$$(\Delta S)_{\text{univ}} \geq 0$$

$$\left(C_p \ln \frac{T_2}{T_i} + C_p \ln \frac{T_2'}{T_i} \right) \geq 0$$

$$C_p \ln \frac{T_2 T_2'}{T_i^2} \geq 0 \quad (7.4.2)$$

In equation (7.4.1) with C_p , T_2 , and T_i being given, W will be a minimum when T_2' is a minimum. From Eq. (7.4.2), the minimum value of T_2' would correspond to

$$C_p \ln \frac{T_2 T_2'}{T_i^2} = 0 = \ln 1$$

$$\therefore T_2' = \frac{T_i^2}{T_2}$$

From equation (7.4.1)

$$W_{(\text{min})} = C_p \left(\frac{T_i^2}{T_2} + T_2 - 2T_i \right) \quad \text{Proved.}$$

Example 7.5 Three identical finite bodies of constant heat capacity are at temperatures 300, 300 and 100 K. If no work or heat is supplied from outside, what is the highest temperature to which any one of the bodies can be raised by the operation of heat engines or refrigerators?

Solution Let the three identical bodies A , B , and C having the same heat capacity C be respectively at 300 K, 100 K and 300 K initially, and let us operate a heat engine and a refrigerator, as shown in Fig. Ex. 7.5. Let T_f be the final temperature of bodies A and B , and T_f' be the final temperature of body C . Now

$$\begin{aligned}
 (\Delta S)_A &= C \ln \frac{T_f}{300} \\
 (\Delta S)_B &= C \ln \frac{T_f}{100} \\
 (\Delta S)_C &= C \ln \frac{T'_f}{300} \\
 (\Delta S)_{H.E.} &= 0 \\
 (\Delta S)_{ref} &= 0
 \end{aligned}$$

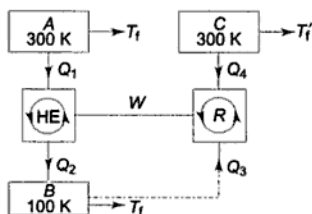

Fig. Ex. 7.5

where C is the heat capacity of each of the three bodies.

Since $(\Delta S)_{univ} \geq 0$

$$\begin{aligned}
 \left(C \ln \frac{T_f}{300} + C \ln \frac{T_f}{100} + C \ln \frac{T'_f}{300} \right) &\geq 0 \\
 C \ln \frac{T_f^2 T'_f}{9,000,000} &\geq 0
 \end{aligned}$$

For minimum value of T_f , $C \ln \frac{T_f^2 T'_f}{9 \times 10^6} = 0 = \ln 1$

$$\therefore T_f^2 T'_f = 9,000,000 \quad (7.5.1)$$

Now

$$\begin{aligned}
 Q_1 &= C(300 - T_f) \\
 Q_2 &= C(T_f - 100) \\
 Q_4 &= C(T'_f - 300)
 \end{aligned}$$

Again

$$\begin{aligned}
 Q_1 &= \text{Heat removed from body A} \\
 &= \text{Heat discharged to bodies B and C} \\
 &= Q_2 + Q_4
 \end{aligned}$$

$$\therefore C(300 - T_f) = C(T_f - 100) + C(T'_f - 300)$$

$$\therefore T'_f = 700 - 2T_f \quad (7.5.2)$$

T'_f will be the highest value when T_f is the minimum.

From equations (7.5.1) and (7.5.2)

$$T_f^2 (700 - 2T_f) = 9,000,000$$

$$\therefore 2T_f^3 - 700 T_f^2 + 9,000,000 = 0$$

$$\text{or } T_f = 150 \text{ K}$$

From Eq. (7.5.2)

$$\begin{aligned} T'_f &= (700 - 2 \times 150)\text{K} \\ &= 400 \text{ K} \end{aligned}$$

Ans.

Example 7.6 A system has a capacity at constant volume

$$C_V = AT^2$$

where $A = 0.042\text{J/K}^3$.

The system is originally at 200 K, and a thermal reservoir at 100 K is available. What is the maximum amount of work that can be recovered as the system is cooled down to the temperature of the reservoir?

Solution Heat removed from the system (Fig. Ex. 7.6)

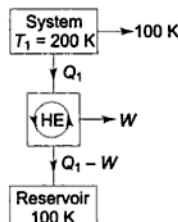

Fig. Ex. 7.6

$$\begin{aligned} Q_1 &= \int_{T_1}^{T_2} C_V dT = \int_{T_1=200\text{ K}}^{T_2=100\text{ K}} 0.042 T^2 dT \\ &= 0.042 \left[\frac{T^3}{3} \right]_{200\text{ K}}^{100\text{ K}} \\ &= \frac{0.042}{3} \text{ J/K}^3 (100^3 - 200^3)\text{K}^3 = -98 \times 10^3 \text{ J} \\ (\Delta S)_{\text{system}} &= \int_{200\text{ K}}^{100\text{ K}} C_V \frac{dT}{T} = \int_{200\text{ K}}^{100\text{ K}} 0.042 T^2 \frac{dT}{T} \\ &= \frac{0.042}{2} \text{ J/K}^3 [100^2 - 200^2]\text{K}^2 \\ &= -630 \text{ J/K} \\ (\Delta S)_{\text{res}} &= \frac{Q_1 - W}{T_{\text{res}}} = \frac{98 \times 10^3 - W}{100} \text{ J/K} \\ (\Delta S)_{\text{working fluid in H.E.}} &= 0 \\ \therefore (\Delta S)_{\text{univ}} &= (\Delta S)_{\text{system}} + (\Delta S)_{\text{res}} \\ &= -630 + \frac{98 \times 10^3 - W}{100} \\ \text{Since } (\Delta S)_{\text{univ}} &\geq 0 \\ \therefore -630 + \frac{98 \times 10^3 - W}{100} &\geq 0 \\ 980 - \frac{W}{100} - 630 &\geq 0 \end{aligned}$$

$$\frac{W}{100} \leq 350$$

$$W_{(\max)} = 35,000 \text{ J} = 35 \text{ kJ}$$

Ans.

Example 7.7 A fluid undergoes a reversible adiabatic compression from 0.5 MPa, 0.2 m³ to 0.05 m³ according to the law, $pV^{1.3} = \text{constant}$. Determine the change in enthalpy, internal energy and entropy, and the heat transfer and work transfer during the process.

Solution

$$TdS = dH - Vdp$$

For the reversible adiabatic process (Fig. Ex. 7.7)

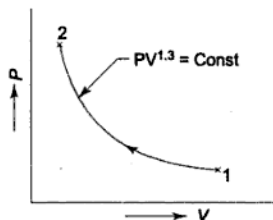

Fig. Ex. 7.7

$$dH = Vdp$$

$$p_1 = 0.5 \text{ MPa}, V_1 = 0.2 \text{ m}^3$$

$$V_2 = 0.05 \text{ m}^3, p_1 V_1^n = p_2 V_2^n$$

∴

$$p_2 = p_1 \left(\frac{V_1}{V_2} \right)^n$$

$$= 0.5 \times \left(\frac{0.20}{0.05} \right)^{1.3} \text{ MPa}$$

$$= 0.5 \times 6.061 \text{ MPa}$$

$$= 3.0305 \text{ MPa}$$

$$p_1 V_1^n = p_2 V_2^n$$

∴

$$V = \left(\frac{p_1 V_1^n}{p} \right)^{1/n}$$

$$\int_{H_1}^{H_2} dH = \int_{p_1}^{p_2} V dp$$

$$H_2 - H_1 = \int_{p_1}^{p_2} \left[\left(\frac{p_1 V_1^n}{p} \right)^{1/n} \right] dp$$

$$\begin{aligned}
 &= (p_1 V_1^n)^{1/n} \left(\frac{p_1^{1-1/n} - p_1^{1-n/n}}{1 - 1/n} \right) \\
 &= \frac{n(p_2 V_2 - p_1 V_1)}{n-1} \\
 &= \frac{1.3(3030.5 \times 0.05 - 500 \times 0.2)}{1.3 - 1} \\
 &= 223.3 \text{ kJ}
 \end{aligned}$$

$$\begin{aligned}
 H_2 - H_1 &= (U_2 + p_2 V_2) - (U_1 + p_1 V_1) \\
 &= (U_2 - U_1) + (p_2 V_2 - p_1 V_1)
 \end{aligned}$$

$$\begin{aligned}
 U_2 - U_1 &= (H_2 - H_1) - (p_2 V_2 - p_1 V_1) \\
 &= 223.3 - 51.53 \\
 &= 171.77 \text{ kJ}
 \end{aligned}$$

Ans.

$$S_2 - S_1 = 0$$

Ans.

$$Q_{1-2} = 0$$

Ans.

$$Q_{1-2} = U_2 - U_1 + W_{1-2}$$

$$W_{1-2} = U_1 - U_2 = -171.77 \text{ kJ}$$

Ans.

Example 7.8 Air is flowing steadily in an insulated duct. The pressure and temperature measurements of the air at two stations *A* and *B* are given below. Establish the direction of the flow of air in the duct. Assume that for air, specific heat c_p is constant at 1.005 kJ/kg K, $h = c_p T$, and $\frac{v}{T} = \frac{0.287}{p}$, where p , v and T are pressure (in kPa), volume (in m^3/kg) and temperature (in K) respectively.

	Station A	Station B
Pressure	130 kPa	100 kPa
Temperature	50°C	13°C

Solution From property relation

$$T ds = dh - v dp$$

$$ds = \frac{dh}{T} - v \frac{dp}{T}$$

For two states at *A* and *B* the entropy change of the system

$$\int_{s_A}^{s_B} ds = \int_{T_A}^{T_B} \frac{c_p dT}{T} - \int_{p_A}^{p_B} \frac{0.287 dp}{p}$$

$$\begin{aligned}
 \therefore s_B - s_A &= 1.005 \ln \frac{T_B}{T_A} - 0.287 \ln \frac{p_B}{p_A} \\
 &= 1.005 \ln \frac{273 + 13}{273 + 50} - 0.287 \ln \frac{100}{130}
 \end{aligned}$$

$$\begin{aligned}
 &= -0.1223 + 0.0753 \\
 &= -0.047 \text{ kJ/kg K} \\
 (\Delta S)_{\text{system}} &= -0.047 \text{ kJ/kg K}
 \end{aligned}$$

Since the duct is insulated $(\Delta S)_{\text{surr}} = 0$

$$(\Delta S)_{\text{univ}} = -0.047 \text{ kJ/kg K}$$

This is impossible. So the flow must be from B to A .

Example 7.9 A hypothetical device is supplied with 2 kg/s of air at 4 bar, 300 K. Two separate streams of air leave the device, as shown in figure below. Each stream is at an ambient pressure of 1 bar, and the mass flow rate is the same for both streams. One of the exit streams is said to be at 330 K while the other is at 270 K. The ambient temperature is at 300 K. Determine whether such a device is possible.

Solution The entropy generation rate for the control volume (Fig. Ex. 7.9) is

$$\begin{aligned}
 \dot{S}_{\text{gen}} &= \sum \dot{m}_e s_e - \sum \dot{m}_i s_i \\
 &= \dot{m}_2 s_2 + \dot{m}_3 s_3 - \dot{m}_1 s_1 \\
 &= \dot{m}_2 s_2 + \dot{m}_3 s_3 - (\dot{m}_2 + \dot{m}_3) s_1 \\
 &= \dot{m}_2 (s_2 - s_1) + \dot{m}_3 (s_3 - s_1)
 \end{aligned}$$

$$\begin{aligned}
 \text{Now,} \quad s_2 - s_1 &= c_p \ln \frac{T_2}{T_1} - R \ln \frac{p_2}{p_1} \\
 &= 1.005 \ln \frac{330}{300} - 0.287 \ln \frac{1}{4} \\
 &= 0.494 \text{ kJ/kgK}
 \end{aligned}$$

$$\begin{aligned}
 s_3 - s_1 &= c_p \ln \frac{T_3}{T_1} - R \ln \frac{p_3}{p_1} \\
 &= 1.005 \ln \frac{270}{300} - 0.287 \ln \frac{1}{4} \\
 &= 0.292 \text{ kJ/kgK}
 \end{aligned}$$

$$\begin{aligned}
 \dot{S}_{\text{gen}} &= 1 \times 0.494 + 1 \times 0.292 \\
 &= 0.786 \text{ kW/K}
 \end{aligned}$$

Since $\dot{S}_{\text{gen}} > 0$, the device is possible. Such devices actually exist and are called *vortex tubes*. Although they have low efficiencies, they are suitable for certain applications like rapid cooling of soldered parts, electronic component cooling, cooling of machining operations and so on. The vortex tube is essentially a passive device with no moving parts. It is relatively maintenance free and durable.

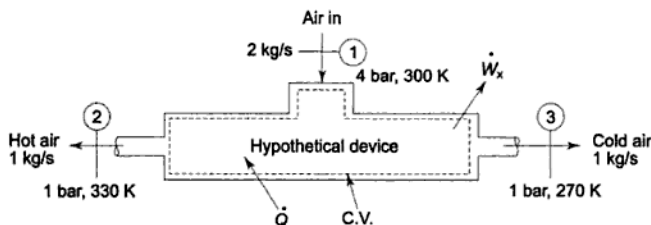

Fig. Ex. 7.9

Example 7.10 A room is maintained at 27°C while the surroundings are at 2°C . The temperatures of the inner and outer surfaces of the wall ($k = 0.71 \text{ W/mK}$) are measured to be 21°C and 6°C , respectively. Heat flows steadily through the wall $5 \text{ m} \times 7 \text{ m}$ in cross-section and 0.32 m in thickness. Determine (a) the rate of heat transfer through the wall, (b) the rate of entropy generation in the wall, and (c) the rate of total entropy generation with this heat transfer process.

Solution

$$\dot{Q} = kA \frac{\Delta T}{L} = 0.71 \frac{\text{W}}{\text{mK}} \times (5 \times 7) \text{m}^2 \times \frac{(21-6)\text{K}}{0.32 \text{ m}}$$

$$= 1164.84 \text{ W} \quad \text{Ans. (a)}$$

Taking the wall as the system, the entropy balance in rate form gives:

$$\frac{dS_{\text{wall}}}{dt} = \dot{S}_{\text{transfer}} + \dot{S}_{\text{gen.wall}}$$

$$0 = \sum \frac{\dot{Q}}{T} + \dot{S}_{\text{gen.wall}}$$

$$0 = \frac{1164.84}{294} - \frac{1164.84}{279} + \dot{S}_{\text{gen.wall}}$$

Rate of entropy generation in the wall

$$\dot{S}_{\text{gen.wall}} = 4.175 - 3.962 = 0.213 \text{ W/K} \quad \text{Ans. (b)}$$

The entropy change of the wall is zero during this process, since the state and hence the entropy of the wall does not change anywhere in the wall.

To determine the rate of total entropy generation during this heat transfer process, we extend the system to include the regions on both sides of the wall,

$$\frac{dS_{\text{total}}}{dt} = \dot{S}_{\text{transfer}} + \dot{S}_{\text{gen.total}}$$

$$0 = \sum \frac{\dot{Q}}{T} + \dot{S}_{\text{gen.total}}$$

$$0 = \frac{1164.84}{300} - \frac{1164.84}{275} + \dot{S}_{\text{gen.total}}$$

$$\dot{S}_{\text{gen.total}} = 4.236 - 3.883 = 0.353 \text{ W/K} \quad \text{Ans. (c)}$$

REVIEW QUESTIONS

- 7.1 Show that through one point there can pass only one reversible adiabetic.
- 7.2 State and prove Clausius' Theorem.
- 7.3 Show that entropy is a property of a system.
- 7.4 How is the entropy change of a reversible process estimated? Will it be different for an irreversible process between the same end states?
- 7.5 Why is the Carnot cycle on T - s plot a rectangle?
- 7.6 State the principle of Caratheodory. How is the existence of entropy function inferred?
- 7.7 Establish the inequality of Clausius.
- 7.8 Give the criteria of reversibility, irreversibility and impossibility of a thermodynamic cycle.
- 7.9 What do you understand by the entropy principle?
- 7.10 When the system is at equilibrium, why would any conceivable change in entropy be zero?
- 7.11 Why is the entropy increase of an isolated system a measure of the extent of irreversibility of the process undergone by the system?
- 7.12 How did Rudolf Clausius summarize the first and second laws of thermodynamics?
- 7.13 Show that the transfer of heat through a finite temperature difference is irreversible.
- 7.14 Show that the diabatic mixing of two fluids is irreversible.
- 7.15 What is the maximum work obtainable from two finite bodies at temperatures T_1 and T_2 ?
- 7.16 Determine the maximum work obtainable by using one finite body at temperature T and a thermal energy reservoir at temperature T_0 , $T > T_0$.
- 7.17 What are the causes of entropy increase?
- 7.18 Why is an isentropic process not necessarily an adiabatic process?
- 7.19 What is the reversible adiabatic work for a steady flow system when K.E. and P.E. changes are negligibly small? How is it different from that for a closed stationary system?
- 7.20 Under what conditions is the work done equal to (a) $\int p \, dv$, (b) $-\int v \, dp$?
- 7.21 Why are the equations

$$TdS = dU + p dV$$

$$TdS = dH - V dp$$

valid for any process between two equilibrium end states?

- 7.22 Why is the second law called a directional law of nature?
- 7.23 How is entropy related to molecular disorder in a system?
- 7.24 Show that entropy varies logarithmically with the disorder number.
- 7.25 What do you understand by perfect order?
- 7.26 Give the Nernst-Simon statement of the third law of thermodynamics.
- 7.27 Why does entropy remain constant in a reversible adiabatic process?
- 7.28 What do you understand by the postulatory approach of thermodynamics?
- 7.29 What do you understand by 'lost work'?

- 7.30 The amount of entropy generation quantifies the intrinsic irreversibility of a process. Explain.
- 7.31 Show that S_{gen} is not a thermodynamic property.
- 7.32 Give the expression for the entropy generation rate for a control volume of a steady flow system.
- 7.33 What is the entropy generation in the isothermal dissipation of work?
- 7.34 What is the entropy generation in the adiabatic dissipation of work?
- 7.35 What do you understand by entropy transfer? Why is entropy transfer associated with heat transfer and not with work transfer?
- 7.36 What is the relation between probability and uncertainty of an event? How is entropy defined in communication theory?
- 7.37 State the five characteristics on which the uncertainty of an event depends. What is the expectation value of uncertainty?
- 7.38 Define information and explain its relation with entropy. What is Shannon's formula?
- 7.39 What is bias? State and explain the principle of minimum prejudice.
- 7.40 Explain the procedure of Jaynes' formalism to prove:

$$S = K\lambda + K\beta \langle V \rangle$$

- 7.41 Explain how information theory is applied to a system of particles. What is partition function?
- 7.42 Explain the relation of information theory and classical thermodynamics.
- 7.43 How do the heat transfer and the lost work affect changes in p_i and hence the entropy of a system?
- 7.44 Since information theory considers heat and work as derived quantities, show that for a reversible process:
- $\delta W_r = -\sum p_i d\varepsilon_i = p dV$
 - $\delta Q + [\delta W_r - \delta W] = \sum \varepsilon_i dp_i$
 - $\delta Q_r = TdS$
- 7.45 Explain how entropy is a fundamental concept in information theory and not a derived function as in classical thermodynamics.

PROBLEMS

- 7.1 On the basis of the first law fill in the blank spaces in the following table of imaginary heat engine cycles. On the basis of the second law classify each cycle as reversible, irreversible, or impossible.

	Cycle Temperature		Rate of Heat Flow		Rate of work	Efficiency
	Source	Sink	Supply	Rejection	output	
(a)	327°C	27°C	420 kJ/s	230 kJ/s	...kW	
(b)	1000°C	100°C	...kJ/min	4.2 MJ/min	...kW	65%
(c)	750 K	300 K	...kJ/s	...kJ/s	26 kW	60%
(d)	700 K	300 K	3 kW	...kW	2 kW	-

- 7.2 The latent heat of fusion of water at 0°C is 335 kJ/kg. How much does the entropy of 1 kg of ice change as it melts into water in each of the following ways:

- (a) Heat is supplied reversibly to a mixture of ice and water at 0°C . (b) A mixture of ice and water at 0°C is stirred by a paddle wheel.
- 7.3 Two kg of water at 80°C are mixed adiabatically with 3 kg of water at 30°C in a constant pressure process of 1 atmosphere. Find the increase in the entropy of the total mass of water due to the mixing process (c_p of water = 4.187 kJ/kg K).
- Ans.* 0.0592 kJ/K
- 7.4 In a Carnot cycle, heat is supplied at 350°C and rejected at 27°C . The working fluid is water which, while receiving heat, evaporates from liquid at 350°C to steam at 350°C . The associated entropy change is 1.44 kJ/kg K . (a) If the cycle operates on a stationary mass of 1 kg of water, how much is the work done per cycle, and how much is the heat supplied? (b) If the cycle operates in steady flow with a power output of 20 kW , what is the steam flow rate?
- Ans.* (a) $465.12, 897.12 \text{ kJ/kg}$, (b) 0.043 kg/s
- 7.5 A heat engine receives reversibly 420 kJ/cycle of heat from a source at 327°C , and rejects heat reversibly to sink at 27°C . There are no other heat transfers. For each of the three hypothetical amounts of heat rejected, in (a), (b), and (c) below, compute the cyclic integral of dQ/T . From these results show which case is irreversible, which reversible, and which impossible: (a) 210 kJ/cycle rejected, (b) 105 kJ/cycle rejected, (c) 315 kJ/cycle rejected.
- Ans.* (a) Reversible, (b) Impossible, (c) Irreversible
- 7.6 In Fig. P.7.6, $abcd$ represents a Carnot cycle bounded by two reversible adiabatics and two reversible isotherms at temperatures T_1 and T_2 ($T_1 > T_2$). The oval figure is a reversible cycle, where heat is absorbed at temperatures less than, or equal to, T_1 , and rejected at temperatures greater than, or equal to, T_2 . Prove that the efficiency of the oval cycle is less than that of the Carnot cycle.

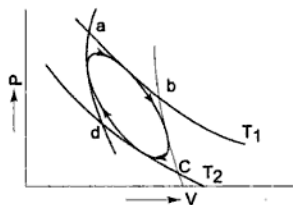

Fig. P. 7.6

- 7.7 Water is heated at a constant pressure of 0.7 MPa . The boiling point is 164.97°C . The initial temperature of water is 0°C . The latent heat of evaporation is 2066.3 kJ/kg . Find the increase of entropy of water, if the final state is steam.
- Ans.* 6.6967 kJ/kg K
- 7.8 One kg of air initially at 0.7 MPa , 20°C changes to 0.35 MPa , 60°C by the three reversible non-flow processes, as shown in Fig. P. 7.8. Process 1-a-2 consists of a constant pressure expansion followed by a constant volume cooling, process 1-b-2 an isothermal expansion followed by a constant pressure expansion, and process 1-c-2 an adiabatic expansion followed by a constant volume heating. Determine the changes of internal energy, enthalpy, and

entropy for each process, and find the work transfer and heat transfer for each process. Takes $c_p = 1.005$ and $c_v = 0.718$ kJ/kg, K and assume the specific heats to be constant. Also assume for air $pv = 0.287 T$, where p is the pressure in kPa, v the specific volume in m^3/kg , and T the temperature in K.

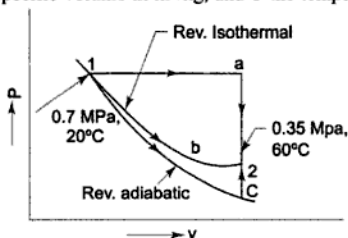

Fig. P. 7.8

- 7.9 Ten grammes of water at 20°C is converted into ice at -10°C at constant atmospheric pressure. Assuming the specific heat of liquid water to remain constant at 4.2 J/gK and that of ice to be half of this value, and taking the latent heat of fusion of ice at 0°C to be 335 J/g, calculate the total entropy change of the system.

Ans. 16.02 J/K

- 7.10 Calculate the entropy change of the universe as a result of the following processes:
- A copper block of 600 g mass and with C_p of 150 J/K at 100°C is placed in a lake at 8°C .
 - The same block, at 8°C , is dropped from a height of 100 m into the lake.
 - Two such blocks, at 100 and 0°C , are joined together.

Ans. (a) 6.63 J/K, (b) 2.095 J/K, (c) 3.64 J/K

- 7.11 A system maintained at constant volume is initially at temperature T_1 , and a heat reservoir at the lower temperature T_0 is available. Show that the maximum work recoverable as the system is cooled to T_0 is

$$W = C_v \left[(T_1 - T_0) - T_0 \ln \frac{T_1}{T_0} \right]$$

- 7.12 A body of finite mass is originally at temperature T_1 which is higher than that of a reservoir at temperature T_2 . Suppose an engine operates in a cycle between the body and the reservoir until it lowers the temperature of the body from T_1 to T_2 , thus extracting heat Q from the body. If the engine does work W , then it will reject heat $Q - W$ to the reservoir at T_2 . Applying the entropy principle, prove that the maximum work obtainable from the engine is

$$W_{(\text{max})} = Q - T_2(S_1 - S_2)$$

where $S_1 - S_2$ is the entropy decrease of the body.

If the body is maintained at constant volume having constant volume heat capacity $C_v = 8.4$ kJ/K which is independent of temperature, and if $T_1 = 373$ K and $T_2 = 303$ K, determine the maximum work obtainable.

Ans. 58.96 kJ

- 7.13 Each of three identical bodies satisfies the equation $U = CT$, where C is the heat capacity of each of the bodies. Their initial temperatures are 200 K, 250 K, and 540 K. If $C = 8.4$ kJ/K, what is the maximum amount of work that can be extracted in a process in which these bodies are brought to a final common temperature?

Ans. 756 kJ

- 7.14 In the temperature range between 0°C and 100°C a particular system maintained at constant volume has a heat capacity.

$$C_v = A + 2BT$$

with $A = 0.014$ J/K and $B = 4.2 \times 10^{-4}$ J/K².

A heat reservoir at 0°C and a reversible work source are available. What is the maximum amount of work that can be transferred to the reversible work source as the system is cooled from 100°C to the temperature of the reservoir?

Ans. 4.508 J

- 7.15 A reversible engine, as shown in Fig. P. 7.15, during a cycle of operation draws 5 MJ from the 400 K reservoir and does 840 kJ of work. Find the amount and direction of heat interaction with other reservoirs.

Ans. $Q_2 = +4.98$ MJ $Q_3 = -0.82$ MJ

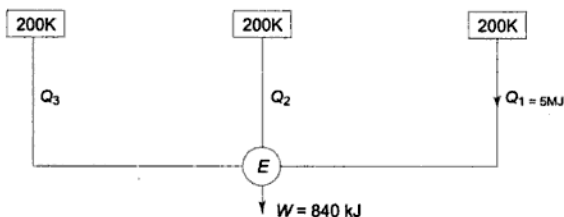

Fig. P. 7.15

- 7.16 For a fluid for which pv/T is a constant quantity equal to R , show that the change in specific entropy between two states A and B is given by

$$s_B - s_A = \int_{T_A}^{T_B} \frac{c_p}{T} dT - R \ln \frac{p_B}{p_A}$$

A fluid for which R is a constant and equal to 0.287 kJ/kg K, flows steadily through an adiabatic machine, entering and leaving through two adiabatic pipes. In one of these pipes the pressure and temperature are 5 bar and 450 K and in the other pipe the pressure and temperature are 1 bar and 300 K respectively. Determine which pressure and temperature refer to the inlet pipe. For the given temperature range, c_p is given by

$$c_p = a \ln T + b$$

where T is the numerical value of the absolute temperature and $a = 0.026$ kJ/kg K, $b = 0.86$ kJ/kg K.

Ans. $s_B - s_A = 0.0509$ kJ/kg K, A is the inlet pipe

- 7.17 Two vessels, A and B , each of volume 3 m^3 may be connected by a tube of negligible volume. Vessel A contains air at 0.7 MPa , 95°C , while vessel B contains air at 0.35 MPa , 205°C . Find the change of entropy when A is connected to B by working from the first principles and assuming the mixing to be complete and adiabatic. For air take the relations as given in Examples. 7.8.

Ans. 0.947 kJ/K

- 7.18 (a) An aluminium block ($c_p = 400 \text{ J/kg K}$) with a mass of 5 kg is initially at 40°C in room air at 20°C . It is cooled reversibly by transferring heat to a completely reversible cyclic heat engine until the block reaches 20°C . The 20°C room air serves as a constant temperature sink for the engine. Compute (i) the change in entropy for the block, (ii) the change in entropy for the room air, (iii) the work done by the engine.

- (b) If the aluminium block is allowed to cool by natural convection to room air, compute (i) the change in entropy for the block, (ii) the change in entropy for the room air (iii) the net change in entropy for the universe.

Ans. (a) -134.2 J/K , $+132 \text{ J/K}$, 1306 J , (b) -132 J/K , $+136.5 \text{ J/K}$, 4.5 J/K

- 7.19 Two bodies of equal heat capacities C and temperatures T_1 and T_2 form an adiabatically closed system. What will the final temperature be if one lets this system come to equilibrium (a) freely? (b) reversibly? (c) What is the maximum work which can be obtained from this system?

- 7.20 A resistor of 30 ohms is maintained at a constant temperature of 27°C while a current of 10 amperes is allowed to flow for 1 sec . Determine the entropy change of the resistor and the universe.

Ans. $(\Delta S)_{\text{resistor}} = 0$, $(\Delta S)_{\text{univ}} = 10 \text{ J/K}$

If the resistor initially at 27°C is now insulated and the same current is passed for the same time, determine the entropy change of the resistor and the universe. The specific heat of the resistor is 0.9 kJ/kg K and the mass of the resistor is 10 g .

Ans. $(\Delta S)_{\text{univ}} = 6.72 \text{ J/K}$

- 7.21 An adiabatic vessel contains 2 kg of water at 25°C . By paddle-wheel work transfer, the temperature of water is increased to 30°C . If the specific heat of water is assumed constant at 4.187 kJ/kg K , find the entropy change of the universe.

Ans. 0.139 kJ/K

- 7.22 A copper rod is of length 1 m and diameter 0.01 m . One end of the rod is at 100°C , and the other at 0°C . The rod is perfectly insulated along its length and the thermal conductivity of copper is 380 W/mK . Calculate the rate of heat transfer along the rod and the rate of entropy production due to irreversibility of this heat transfer.

Ans. 2.985 W , 0.00293 W/K

- 7.23 A body of constant heat capacity C_p and at a temperature T_i is put in contact with a reservoir at a higher temperature T_f . The pressure remains constant while the body comes to equilibrium with the reservoir. Show that the entropy change of the universe is equal to

$$C_p \left[\frac{T_i - T_f}{T_f} - \ln \left(1 + \frac{T_i - T_f}{T_f} \right) \right]$$

Prove that this entropy change is positive.

Given:
$$\ln(1+x) = x - \frac{x^2}{2} + \frac{x^3}{3} - \frac{x^4}{4} + \dots$$

where $x < 1$.

- 7.24 An insulated 0.75 kg copper calorimeter can containing 0.2 kg water is in equilibrium at a temperature of 20°C. An experimenter now places 0.05 kg of ice at 0°C in the calorimeter and encloses the latter with a heat insulating shield. (a) When all the ice has melted and equilibrium has been reached, what will be the temperature of water and the can? The specific heat of copper is 0.418 kJ/kg K and the latent heat of fusion of ice is 333 kJ/kg. (b) Compute the entropy increase of the universe resulting from the process. (c) What will be the minimum work needed by a stirrer to bring back the temperature of water to 20°C?

Ans. (a) 4.68°C, (b) 0.00276 kJ/K, (c) 20.84 kJ

- 7.25 Show that if two bodies of thermal capacities C_1 and C_2 at temperatures T_1 and T_2 are brought to the same temperature T by means of a reversible heat engine, then

$$\ln T = \frac{C_1 \ln T_1 + C_2 \ln T_2}{C_1 + C_2}$$

- 7.26 Two blocks of metal, each having a mass of 10 kg and a specific heat of 0.4 kJ/kg K, are at a temperature of 40°C. A reversible refrigerator receives heat from one block and rejects heat to the other. Calculate the work required to cause a temperature difference of 100°C between the two blocks.

Ans. 32 kJ

- 7.27 A block of iron weighing 100 kg and having a temperature of 100°C is immersed in 50 kg of water at a temperature of 20°C. What will be the change of entropy of the combined system of iron and water? Specific heats of iron and water are 0.45 and 4.18 kJ/kg K respectively.

Ans. 1.24 kJ/K

- 7.28 36 g of water at 30°C are converted into steam at 250°C at constant atmospheric pressure. The specific heat of water is assumed constant at 4.2 J/gK and the latent heat of vaporization at 100°C is 2260 J/g. For water vapour, assume $pV = mRT$ where $R = 0.4619$ kJ/kg K, and

$$\frac{c_p}{R} = a + bT + cT^2, \text{ where } a = 3.634,$$

$$b = 1.195 \times 10^{-3} \text{ K}^{-1} \text{ and } c = 0.135 \times 10^{-6} \text{ K}^{-2}$$

Calculate the entropy change of the system.

Ans. 273.1 J/K

- 7.29 A 50 ohm resistor carrying a constant current of 1 A is kept at a constant temperature of 27°C by a stream of cooling water. In a time interval of 1 s, (a) what is the change in entropy of the resistor? (b) What is the change in entropy of the universe?

Ans. (a) 0, (b) 0.167 J/K

- 7.30 A lump of ice with a mass of 1.5 kg at an initial temperature of 260 K melts at the pressure of 1 bar as a result of heat transfer from the environment. After some

time has elapsed the resulting water attains the temperature of the environment, 293 K. Calculate the entropy production associated with this process. The latent heat of fusion of ice is 333.4 kJ/kg, the specific heats of ice and water are 2.07 and 4.2 kJ/kg K respectively, and ice melts at 273.15 K.

Ans. 0.1514 kJ/K

- 7.31 An ideal gas is compressed reversibly and adiabatically from state a to state b . It is then heated reversibly at constant volume to state c . After expanding reversibly and adiabatically to state d such that $T_b = T_d$, the gas is again reversibly heated at constant pressure to state e such that $T_e = T_c$. Heat is then rejected reversibly from the gas at constant volume till it returns to state a . Express T_a in terms of T_b and T_c . If $T_b = 555$ K and $T_c = 835$ K, estimate T_a . Take $\gamma = 1.4$.

$$\text{Ans. } T_a = \frac{T_b^{\gamma+1}}{T_c^\gamma}, 313.29 \text{ K}$$

- 7.32 Liquid water of mass 10 kg and temperature 20°C is mixed with 2 kg of ice at -5°C till equilibrium is reached at 1 atm pressure. Find the entropy change of the system. Given: c_p of water = 4.18 kJ/kg K, c_p of ice = 2.09 kJ/kg K and latent heat of fusion of ice = 334 kJ/kg.

Ans. 104.9 J/K

- 7.33 A thermally insulated 50-ohm resistor carries a current of 1 A for 1 s. The initial temperature of the resistor is 10°C. Its mass is 5 g and its specific heat is 0.85 J/g K. (a) What is the change in entropy of the resistor? (b) What is the change in entropy of the universe?

Ans. (a) 0.173 J/K (b) 0.173 J/K

- 7.34 The value of c_p for a certain substance can be represented by $c_p = a + bT$. (a) Determine the heat absorbed and the increase in entropy of a mass m of the substance when its temperature is increased at constant pressure from T_1 to T_2 . (b) Find the increase in the molal specific entropy of copper, when the temperature is increased at constant pressure from 500 to 1200 K. Given for copper: when $T = 500$ K, $c_p = 25.2 \times 10^3$ and when $T = 1200$ K, $c_p = 30.1 \times 10^3$ J/k mol K.

$$\text{Ans. (a) } m \left[a(T_2 - T_1) + \frac{b}{2}(T_2^2 - T_1^2) \right] m \left[a \ln \frac{T_2}{T_1} + b(T_2 - T_1) \right]$$

(b) 23.9 kJ/k mol K

- 7.35 An iron block of unknown mass at 85°C is dropped into an insulated tank that contains 0.1 m³ of water at 20°C. At the same time a paddle-wheel driven by a 200 W motor is activated to stir the water. Thermal equilibrium is established after 20 min when the final temperature is 24°C. Determine the mass of the iron block and the entropy generated during the process.

Ans. 52.2 kg, 1.285 kJ/K

- 7.36 A piston-cylinder device contains 1.2 kg of nitrogen gas at 120 kPa and 27°C. The gas is now compressed slowly in a polytropic process during which $pV^{1.3} = \text{constant}$. The process ends when the volume is reduced by one-half. Determine the entropy change of nitrogen during this process.

Ans. -0.0615 kJ/K.

- 7.37 Air enters a compressor at ambient conditions of 96 kPa and 17°C with a low velocity and exits at 1 MPa, 327°C, and 120 m/s. The compressor is cooled by the ambient air at 17°C at a rate of 1500 kJ/min. The power input to the compressor is 300 kW. Determine (a) the mass flow rate of air and (b) the rate of entropy generation.

Ans. (a) 0.851 kg/s, (b) 0.144 kW/K

- 7.38 A gearbox operating at steady state receives 0.1 kW along the input shaft and delivers 0.095 kW along the output shaft. The outer surface of the gearbox is at 50°C. For the gearbox, determine (a) the rate of heat transfer, (b) the rate at which entropy is produced.

Ans. (a) -0.005 kW, (b) 1.54×10^{-5} kW/K

- 7.39 At steady state, an electric motor develops power along its output shaft at the rate of 2 kW while drawing 20 amperes at 120 volts. The outer surface of the motor is at 50°C. For the motor, determine the rate of heat transfer and the rate of entropy generation.

Ans. -0.4 kW, 1.24×10^{-3} kW/K

- 7.40 Show that the minimum theoretical work input required by a refrigeration cycle to bring two finite bodies from the same initial temperature to the final temperatures of T_1 and T_2 ($T_2 < T_1$) is given by

$$W_{\min} = mc [2(T_1 T_2)^{1/2} - T_1 - T_2]$$

- 7.41 A rigid tank contains an ideal gas at 40°C that is being stirred by a paddle wheel. The paddle wheel does 200 kJ of work on the ideal gas. It is observed that the temperature of the ideal gas remains constant during this process as a result of heat transfer between the system and the surroundings at 25°C. Determine (a) the entropy change of the ideal gas and (b) the total entropy generation.

Ans. (a) 0, (b) 0.671 kJ/K

- 7.42 A cylindrical rod of length L insulated on its lateral surface is initially in contact at one end with a wall at temperature T_1 and at the other end with a wall at a lower temperature T_2 . The temperature within the rod initially varies linearly with position x according to:

$$T(x) = T_1 - \frac{T_1 - T_2}{L} x$$

The rod is insulated on its ends and eventually comes to a final equilibrium state where the temperature is T_f . Evaluate T_f and in terms of T_1 and T_2 , and show that the amount of entropy generated is:

$$S_{\text{gen}} = mc \left[1 + \ln T_f + \frac{T_2}{T_1 - T_2} \ln T_2 - \frac{T_1}{T_1 - T_2} \ln T_1 \right]$$

where c is the specific heat of the rod.

Ans. $T_f = [T_1 + T_2]/2$

- 7.43 Air flowing through a horizontal, insulated duct was studied by students in a laboratory. One student group measured the pressure, temperature, and velocity at a location in the duct as 0.95 bar, 67°C, 75 m/s. At another location the respective values were found to be 0.8 bar, 22°C, 310 m/s. The group

neglected to note the direction of flow, however. Using the known data, determine the direction.

Ans. Flow is from right to left

- 7.44 Nitrogen gas at 6 bar, 21°C enters an insulated control volume operating at steady state for which $W_{C.V.} = 0$. Half of the nitrogen exits the device at 1 bar, 82°C and the other half exits at 1 bar, -40°C. The effects of KE and PE are negligible. Employing the ideal gas model, decide whether the device can operate as described.

Ans. Yes, the device can operate as described

Available Energy, Exergy and Irreversibility

8.1 Available Energy

The sources of energy can be divided into two groups, viz. high grade energy and low grade energy. The conversion of high grade energy to shaft work is exempted from the limitations of the second law, while conversion of low grade energy is subject to them.

The examples of two kinds of energy are:

High grade energy

- (a) Mechanical work
- (b) Electrical energy
- (c) Water power
- (d) Wind power
- (e) Kinetic energy of a jet
- (f) Tidal power

Low grade energy

- (a) Heat or thermal energy
- (b) Heat derived from nuclear fission or fusion
- (c) Heat derived from combustion of fossil fuels

The bulk of the high grade energy in the form of mechanical work or electrical energy is obtained from sources of low grade energy, such as fuels, through the medium of the cyclic heat engine. The complete conversion of low grade energy, heat, into high grade energy, shaft-work, is impossible by virtue of the second law of thermodynamics. That part of the low grade energy which is available for conversion is referred to as available energy, while the part which, according to the second law, must be rejected, is known as *unavailable energy*.

Josiah Willard Gibbs is accredited with being the originator of the availability concept. He indicated that environment plays an important part in evaluating the available energy.

8.2 Available Energy Referred to a Cycle

The maximum work output obtainable from a certain heat input in a cyclic heat engine (Fig. 8.1) is called the *available energy* (A.E.), or the available part of the energy supplied. The minimum energy that has to be rejected to the sink by the second law is called the *unavailable energy* (U.E.), or the unavailable part of the energy supplied.

Therefore, $Q_1 = \text{A.E.} + \text{U.E.}$

or $W_{\max} = \text{A.E.} = Q_1 - \text{U.E.}$

For the given T_1 and T_2 ,

$$\eta_{\text{rev}} = 1 - \frac{T_2}{T_1}$$

For a given T_1 , η_{rev} will increase with the decrease of T_2 . The lowest practicable temperature of heat rejection is the *temperature of the surroundings*, T_0

$$\therefore \eta_{\max} = 1 - \frac{T_0}{T_1}$$

and
$$W_{\max} = \left(1 - \frac{T_0}{T_1}\right) Q_1$$

Let us consider a finite process x - y , in which heat is supplied reversibly to a heat engine (Fig. 8.2). Taking an elementary cycle, if δQ_1 is the heat received by the engine reversibly at T_1 , then

$$\delta W_{\max} = \frac{T_1 - T_0}{T_1} \delta Q_1 = \delta Q_1 - \frac{T_0}{T_1} \delta Q_1 = \text{A.E.}$$

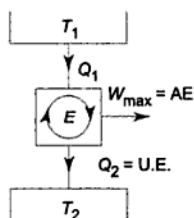

Fig. 8.1 Available and unavailable energy in a cycle

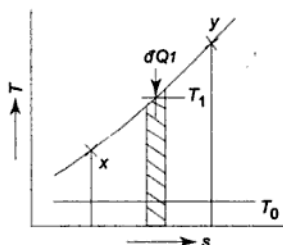

Fig. 8.2 Availability of energy

For the heat engine receiving heat for the whole process x - y , and rejecting heat at T_0

$$\int_x^y dW_{\max} = \int_x^y dQ_1 - \int_x^y \frac{T_0}{T_1} dQ_1$$

$$\therefore W_{\max} = \text{A.E.}$$

$$= Q_{xy} - T_0 (s_y - s_x) \quad (8.2)$$

$$\text{or U.E.} = Q_{xy} - W_{\max}$$

$$\text{or U.E.} = T_0 (s_y - s_x)$$

The unavailable energy is thus the product of the lowest temperature of heat rejection, and the change of entropy of the system during the process of supplying heat (Fig. 8.3). The available energy is also known as *exergy* and the unavailable energy as *energy*, the words first coined by Rant (1956).

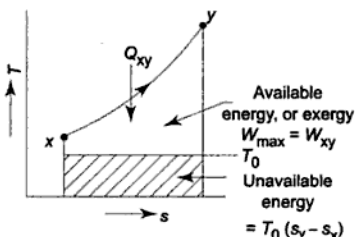

Fig. 8.3 Unavailable energy by the second law

8.2.1 Decrease in Available Energy when Heat is Transferred through a Finite Temperature Difference

Whenever heat is transferred through a finite temperature difference, there is a decrease in the availability of energy so transferred.

Let us consider a reversible heat engine operating between T_1 and T_0 (Fig. 8.4). Then

$$Q_1 = T_1 \Delta s, \quad Q_2 = T_0 \Delta s, \quad \text{and } W = \text{A.E.} = (T_1 - T_0) \Delta s$$

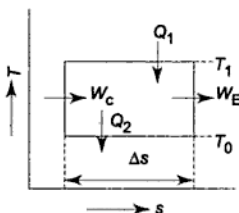

Fig. 8.4 Carnot cycle

Let us now assume that heat Q_1 is transferred through a finite temperature difference from the reservoir or source at T_1 to the engine absorbing heat at T_1' , lower than T_1 (Fig. 8.5). The availability of Q_1 as received by the engine at T_1'

lower than T_1 (Fig. 8.5). The availability of Q_1 as received by the engine at T_1' can be found by allowing the engine to operate reversibly in a cycle between T_1' and T_0 receiving Q_1 and rejecting Q_2 .

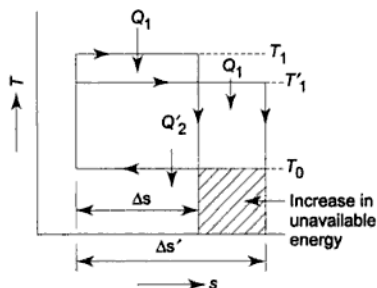

Fig. 8.5 Increase in unavailable energy due to heat transfer through a finite temperature difference

Now	$Q_1 = T_1 \Delta s = T_1' \Delta s'$
since	$T_1 > T_1', \therefore \Delta s' > \Delta s$
	$Q_2 = T_0 \Delta s$
	$Q_2' = T_0 \Delta s'$
Since	$\Delta s' > \Delta s \therefore Q_2' > Q_2$
\therefore	$W' = Q_1 - Q_2' = T_1' \Delta s' - T_0 \Delta s'$
and	$W = Q_1 - Q_2 = T_1 \Delta s - T_0 \Delta s$
\therefore	$W' < W$, because $Q_2' > Q_2$

Available energy or exergy lost due to irreversible heat transfer through finite temperature difference between the source and the working fluid during the heat addition process is given by

$$W - W' = Q_2' - Q_2 \\ = T_0 (\Delta s' - \Delta s)$$

or, decrease in A.E. = $T_0 (\Delta s' - \Delta s)$

The decrease in available energy or exergy is thus the product of the lowest feasible temperature of heat rejection and the additional entropy change in the system while receiving heat irreversibly, compared to the case of reversible heat transfer from the same source.

The greater is the temperature difference ($T_1 - T_1'$), the greater is the heat rejection Q_2' and the greater will be the unavailable part of the energy supplied or energy (Fig. 8.5). Energy is said to be degraded each time it flows through a finite temperature difference.

8.2.2 Available Energy from a Finite Energy Source

Let us consider a hot gas of mass m_g at temperature T when the environmental temperature is T_0 (Fig. 8.6). Let the gas be cooled at constant pressure from state 1 at temperature T to state 3 at temperature T_0 and the heat given up by the gas, Q_1 , be utilized in heating up reversibly a working fluid of mass m_{wf} from state 3 to state 1 along the same path so that the temperature difference between the gas and the working fluid at any instant is zero and hence, the entropy increase of the universe is also zero. The working fluid expands reversibly and adiabatically in an engine or turbine from state 1 to state 2 doing work W_E , and then rejects heat Q_2 reversibly and isothermally to return to the initial state 3 to complete a heat engine cycle.

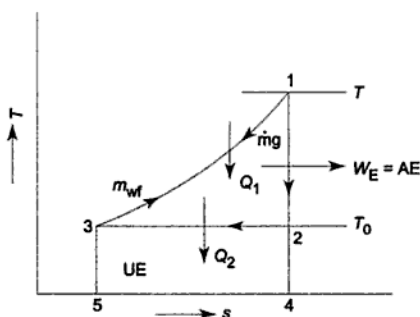

Fig. 8.6 Available energy of a finite energy source

Here,

$$Q_1 = m_g c_{p_g} (T - T_0) = m_{wf} c_{p_{wf}} (T - T_0) \\ = \text{Area } 1-4-5-3-1$$

\therefore

$$m_g c_{p_g} = m_{wf} c_{p_{wf}} \\ \Delta S_{\text{gas}} = \int_T^{T_0} m_g c_{p_g} \frac{dT}{T} = m_g c_{p_g} \ln \frac{T_0}{T} \text{ (negative)}$$

$$\Delta S_{\text{wf}} = \int_{T_0}^T m_{wf} c_{p_{wf}} \frac{dT}{T} = m_{wf} c_{p_{wf}} \ln \frac{T}{T_0} \text{ (positive)}$$

\therefore

$$\Delta S_{\text{univ}} = \Delta S_{\text{gas}} + \Delta S_{\text{wf}} = 0$$

$$Q_2 = T_0 \Delta S_{\text{wf}} = T_0 m_{wf} c_{p_{wf}} \ln \frac{T}{T_0} = \text{Area } 2-4-5-3$$

\therefore

$$\text{Available energy} = W_{\text{max}} \\ = Q_1 - Q_2$$

$$= m_g c_{p_g} (T - T_0) - T_0 m_g c_{p_g} \ln \frac{T}{T_0}$$

$$= \text{Area 1-2-3-1}$$

Therefore, the available energy or exergy of a gas of mass m_g at temperature T is given by

$$AE = m_g c_{p_g} \left[(T - T_0) - T_0 \ln \frac{T}{T_0} \right] \quad (8.4)$$

This is similar to Eq. (7.22) derived from the entropy principle.

8.3 Quality of Energy

Let us assume that a hot gas is flowing through a pipeline (Fig. 8.7). Due to heat loss to the surroundings, the temperature of the gas decreases continuously from inlet at state a to the exit at state b . Although the process is irreversible, let us assume a reversible isobaric path between the inlet and exit states of the gas (Fig. 8.8). For an infinitesimal reversible process at constant pressure,

$$dS = \frac{mc_p dT}{T}$$

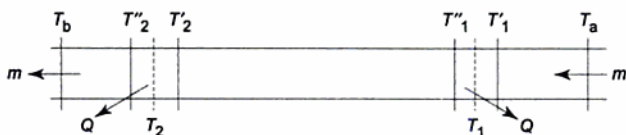

Fig. 8.7 Heat loss from a hot gas flowing through a pipeline

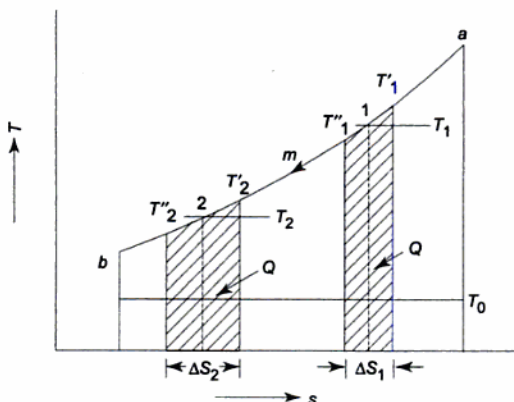

Fig. 8.8 Energy quality at state 1 is superior to that at state 2

$$\text{or } \frac{dT}{dS} = \frac{T}{mc_p} \quad (8.5)$$

where m is the mass of gas flowing and c_p is its specific heat. The slope dT/dS depends on the gas temperature T . As T increases, the slope increases, and if T decreases the slope decreases.

Let us assume that Q units of heat are lost to the surroundings as the temperature of the gas decreases from T'_1 to T''_1 , T_1 being the average of the two. Then,

$$\begin{aligned} \text{Heat loss} \quad Q &= mc_p (T'_1 - T''_1) \\ &= T_1 \Delta S_1 \end{aligned} \quad (8.6)$$

Exergy lost with this heat loss at temperature T_1 is

$$W_1 = Q - T_0 \Delta S_1 \quad (8.7)$$

When the gas temperature has reached T_2 ($T_2 < T_1$), let us assume that the same heat loss Q occurs as the gas temperature decreases from T'_2 to T''_2 , T_2 being the average temperature of the gas. Then

$$\text{Heat loss} \quad Q = mc_p (T'_2 - T''_2) = T_2 \Delta S_2 \quad (8.8)$$

Exergy lost with this heat loss at temperature T_2 is

$$W_2 = Q - T_0 \Delta S_2 \quad (8.9)$$

From Eqs (8.6) and (8.8), since $T_1 > T_2$

$$\Delta S_1 < \Delta S_2$$

Therefore, from Eqs (8.7) and (8.9),

$$W_1 > W_2 \quad (8.10)$$

The loss of exergy is more, when heat loss occurs at a higher temperature T_1 than when the same heat loss occurs at a lower temperature T_2 . Therefore, a heat loss of 1 kJ at, say, 1000°C is more harmful than the same heat loss of 1 kJ at, say, 100°C. Adequate insulation must be provided for high temperature fluids ($T \gg T_0$) to prevent the precious heat loss. This may not be so important for low temperature fluids ($T \sim T_0$), since the loss of available energy from such fluids would be low. (Similarly, insulation must be provided adequately for very low temperature fluids ($T \ll T_0$) to prevent heat gain from surroundings and preserve available energy.)

The available energy or exergy of a fluid at a higher temperature T_1 is more than that at a lower temperature T_2 , and decreases as the temperature decreases. When the fluid reaches the ambient temperature, its exergy is zero.

The second law, therefore, affixes a quality to energy of a system at any state. The quality of energy of a gas at, say, 1000°C is superior to that at, say, 100°C, since the gas at 1000°C has the capacity of doing more work than the gas at 100°C, under the same environmental conditions. An awareness of this energy quality as of energy quantity is essential for the efficient use of our energy resources and for energy conservation. The concept of *available energy or exergy* provides a useful measure of this energy quality.

8.3.1 Law of Degradation of Energy

The available energy of a system decreases as its temperature or pressure decreases and approaches that of the surroundings. When heat is transferred from a system, its temperature decreases and hence the quality of its energy deteriorates. The degradation is more for energy loss at a higher temperature than that at a lower temperature. Quantity-wise the energy loss may be the same, but quality-wise the losses are different. *While the first law states that energy is always conserved quantity-wise, the second law emphasizes that energy always degrades quality-wise.* When a gas is throttled adiabatically from a high to a low pressure, the enthalpy (or energy per unit mass) remains the same, but there is a degradation of energy or available work. The same holds good for pressure drop due to friction of a fluid flowing through an insulated pipe. If the first law is the law of conservation of energy, the second law is called the *law of degradation of energy*. Energy is always conserved, but its quality is always degraded.

Article 8.2.1 which shows how energy gets degraded by thermal irreversibility and produces less useful work can be explained in a little different way. Let two bodies 1 and 2 of constant heat capacities C_1 and C_2 be at temperatures T_1 and T_2 ($T_1 > T_2$). These are connected by a rod and a small quantity of heat Q flows from 1 to 2. The total change of entropy is:

$$\Delta S = \Delta S_1 + \Delta S_2 = Q \left[\frac{1}{T_2} - \frac{1}{T_1} \right] > 0 \quad (\text{since } T_1 > T_2)$$

The entropy will continue to increase till thermal equilibrium is reached.

Let us now suppose that instead of allowing heat Q to flow from 1 to 2, we used it to operate a Carnot engine and obtain mechanical work, with T_0 as the sink temperature. The maximum work obtainable is:

$$W_1 = Q \left[1 - \frac{T_0}{T_1} \right]$$

If, however, we first allow Q to flow from 1 to 2 and then use it to operate the Carnot engine, we obtain:

$$W_2 = Q \left[1 - \frac{T_0}{T_2} \right] < W_1$$

Thus, in the course of the irreversible heat conduction the energy has become degraded to the extent that the useful work has been decreased by

$$\Delta W = W_1 - W_2 = T_0 \Delta S$$

The increase in entropy in an irreversible change is thus a measure of the extent to which energy becomes degraded in that change. Conversely, in order to extract the maximum work from a system, changes must be performed in a reversible manner so that total entropy ($\Delta S_{\text{sys}} + \Delta S_{\text{sur}}$) is conserved.

It is worth pointing that if the two bodies were allowed to reach thermal equilibrium (a) by heat conduction and (b) by operating a Carnot engine between

them and extracting work, the final equilibrium temperatures would be different in the two cases. In the first, $U_1 + U_2$ is conserved and the final temperature is:

$$T_f^{(U)} = \frac{C_1 T_1 + C_2 T_2}{C_1 + C_2}$$

In the second case, $S_1 + S_2$ is conserved and $W = -\Delta U (-\Delta U_1 + U_2)$ ($\because \delta W = \delta Q - dU, < T dS - dU$ so that $\delta W_{\max} = -dU$). In the isentropic process, the final temperature is given by:

$$T_f^{(S)} = T_1^{C_1/(C_1 + C_2)} T_2^{C_2/(C_1 + C_2)} < T_f^{(U)}$$

If $C_1 = C_2 = C$, $T_f^{(U)} = \frac{T_1 + T_2}{2}$ and $T_f^{(S)} = (T_1 T_2)^{1/2}$

The difference in final temperature is due to the lower value of the total internal energy which results from work having been done at the expense of internal energy (see Art. 7.9.3).

Similarly, it can be shown that due to mechanical irreversibility also, energy gets degraded so that the degradation of energy quality is a universal principle.

8.4 Maximum Work in a Reversible Process

Let us consider a closed stationary system undergoing a reversible process R from state 1 to state 2 by interacting with the surroundings at p_0, T_0 (Fig. 8.9). Then by the first law,

$$Q_R = U_2 - U_1 + W_R \quad (8.11)$$

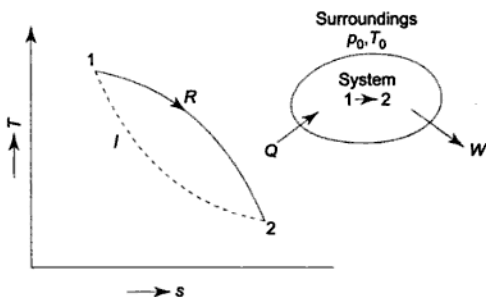

Fig. 8.9 Maximum work done by a closed system

If the process were irreversible, as represented by the dotted line I , connecting the same equilibrium end states,

$$Q_I = U_2 - U_1 + W_I \quad (8.12)$$

Therefore, from Eqs (8.11) and (8.12),

$$Q_R - Q_I = W_R - W_I \quad (8.13)$$

Now,

$$\Delta S_{\text{sys}} = S_2 - S_1$$

and
$$\Delta S_{\text{surr}} = -\frac{Q}{T_0}$$

By the second law,

$$\Delta S_{\text{univ}} \geq 0$$

For a reversible process,

$$\Delta S_{\text{univ}} = S_2 - S_1 - \frac{Q_R}{T_0} = 0$$

$$\therefore Q_R = T_0 (S_2 - S_1) \quad (8.14)$$

For an irreversible process,

$$\Delta S_{\text{univ}} > 0$$

$$\therefore S_2 - S_1 - \frac{Q_1}{T_0} > 0$$

$$\therefore Q_1 < T_0 (S_2 - S_1) \quad (8.15)$$

From Eqs (8.14) and (8.15),

$$Q_R > Q_1 \quad (8.16)$$

Therefore, from Eqs (8.13) and (8.16),

$$W_R > W_1 \quad (8.17)$$

Therefore, the work done by a closed system by interacting only with the surroundings at p_0, T_0 in a reversible process is always more than that done by it in an irreversible process between the same end states.

8.4.1 Work done in all Reversible Processes is the Same

Let us assume two reversible processes R_1 and R_2 between the same end states 1 and 2 undergone by a closed system by exchanging energy only with the surroundings (Fig. 8.10). Let one of the processes be reversed.

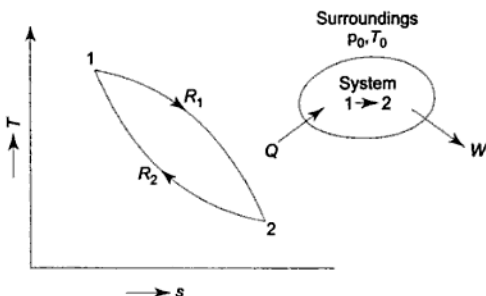

Fig. 8.10 Equal work done in all reversible processes between the same end states

Then the system would execute a cycle 1-2-1 and produce network represented by the area enclosed by exchanging energy with only one reservoir, i.e. the surroundings. This violates the Kelvin-Planck statement. Therefore, *the two reversible processes must coincide and produce equal amounts of work.*

8.5 Reversible Work by an Open System Exchanging Heat only with the Surroundings

Let us consider an open system exchanging energy only with the surroundings at constant temperature T_0 and at constant pressure p_0 (Fig. 8.11). A mass dm_1 enters the system at state 1, a mass dm_2 leaves the system at state 2, an amount of heat dQ is absorbed by the system, an amount of work dW is delivered by the system, and the energy of the system (control volume) changes by an amount $d(E)_\sigma$. Applying the first law, we have

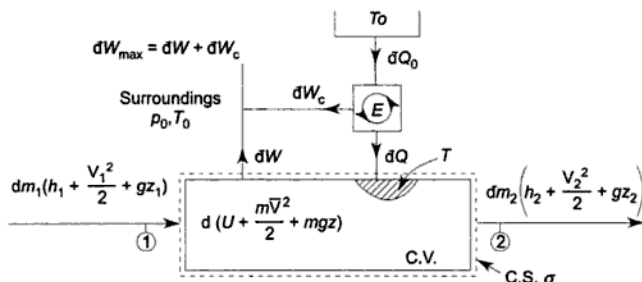

Fig. 8.11 Reversible work done by an open system while exchanging heat only with the surroundings

$$\begin{aligned} dQ + dm_1 \left(h_1 + \frac{V_1^2}{2} + gz_1 \right) - dm_2 \left(h_2 + \frac{V_2^2}{2} + gz_2 \right) - dW \\ = dE_\sigma = d \left(U + \frac{mV^2}{2} + mgz \right)_\sigma \end{aligned} \quad (8.18)$$

For the maximum work, the process must be entirely reversible. There is a temperature difference between the control volume and the surroundings. To make the heat transfer process reversible, let us assume a reversible heat engine E operating between the two. Again, the temperature of the fluid in the control volume may be different at different points. It is assumed that heat transfer occurs at points of the control surface σ where the temperature is T . Thus in an infinitesimal reversible process an amount of heat dQ_0 is absorbed by the engine E from the surroundings at temperature T_0 , an amount of heat dQ is rejected by the engine reversibly to the system where the temperature is T , and an amount of work dW_c is done by the engine. For a reversible engine,

$$\frac{dQ_0}{T_0} = \frac{dQ}{T}$$

$$\therefore dW_c = dQ_0 - dQ = dQ \cdot \frac{T_0}{T} - dQ$$

$$\text{or} \quad dW_c = dQ \left(\frac{T_0}{T} - 1 \right) \quad (8.19)$$

The work dW_c is always positive and is independent of the direction of heat flow. When $T_0 > T$, heat will flow from the surroundings to the system, dQ is positive and hence dW_c in Eq. (8.19) would be positive. Again, when $T_0 < T$, heat will flow from the system surroundings, dQ is negative, and hence dW_c would be positive.

Now, since the process is reversible, the entropy change of the system will be equal to the net entropy transfer, and $S_{\text{gen}} = 0$. Therefore,

$$\begin{array}{l} dS \\ \text{Entropy} \\ \text{change} \end{array} = \begin{array}{l} \frac{dQ}{T} \\ \text{Entropy transfer} \\ \text{with heat} \end{array} + \begin{array}{l} dm_1 s_1 - dm_2 s_2 \\ \text{Entropy transfer} \\ \text{with mass} \end{array}$$

$$\therefore \frac{dQ}{T} = dS - dm_1 s_1 + dm_2 s_2 \quad (8.20)$$

Now, the maximum work is equal to the sum of the system work dW and the work dW_c of the reversible engine E ,

$$dW_{\text{max}} = dW_{\text{rev}} = dW + dW_c \quad (8.21)$$

From Eq. (8.19),

$$dW_{\text{max}} = dW + dQ \left(\frac{T_0}{T} - 1 \right) \quad (8.22)$$

Substituting Eq. (8.18) for dW in Eq. (8.22),

$$\begin{aligned} dW_{\text{max}} &= dQ + dm_1 \left(h_1 + \frac{V_1^2}{2} + gz_1 \right) - dm_2 \left(h_2 + \frac{V_2^2}{2} + gz_2 \right) \\ &\quad - d \left[U + \frac{mV^2}{2} + mgz \right] + dQ \left(\frac{T_0}{T} - 1 \right) \\ &= dm_1 \left(h_1 + \frac{V_1^2}{2} + gz_1 \right) - dm_2 \left(h_2 + \frac{V_2^2}{2} + gz_2 \right) \\ &\quad - d \left[U + \frac{mV^2}{2} + mgz \right] + \frac{dQ}{T} T_0 \end{aligned} \quad (8.23)$$

On substituting the value of dQ/T from Eq. (8.20),

$$\begin{aligned} dW_{\max} &= dm_1 \left(h_1 + \frac{V_1^2}{2} + gz_1 \right) - dm_2 \left(h_2 + \frac{V_2^2}{2} + gz_2 \right) \\ &\quad - d \left[U + \frac{mV^2}{2} + mgz \right]_{\sigma} + T_0 (dS - dm_1 s_1 + dm_2 s_2) \\ \therefore dW_{\max} &= dm_1 \left(h_1 - T_0 s_1 + \frac{V_1^2}{2} + gz_1 \right) - dm_2 \left(h_2 - T_0 s_2 + \frac{V_2^2}{2} + gz_2 \right) \\ &\quad - d \left[U - T_0 S + \frac{mV^2}{2} + mgz \right]_{\sigma} \end{aligned} \quad (8.24)$$

Equation (8.24) is the general expression for the maximum work of an open system which exchanges heat only with the surroundings at T_0, p_0 .

8.5.1 Reversible Work in a Steady Flow Process

For a steady flow process

$$dm_1 = dm_2 = dm$$

$$\text{and} \quad d \left[U - T_0 S + \frac{mV^2}{2} + mgz \right]_{\sigma} = 0$$

Equation (8.24) reduces to

$$dW_{\max} = dm \left[\left(h_1 - T_0 s_1 + \frac{V_1^2}{2} + gz_1 \right) - \left(h_2 - T_0 s_2 + \frac{V_2^2}{2} + gz_2 \right) \right] \quad (8.25)$$

For total mass flow, the integral form of Eq. (8.25) becomes

$$W_{\max} = \left(H_1 - T_0 S_1 + \frac{mV_1^2}{2} + mgz_1 \right) - \left(H_2 - T_0 S_2 + \frac{mV_2^2}{2} + mgz_2 \right) \quad (8.26)$$

The expression $(H - T_0 S)$ is called the *Keenan function*, B .

$$\begin{aligned} \therefore W_{\max} &= \left(B_1 + \frac{mV_1^2}{2} + mgz_1 \right) - \left(B_2 + \frac{mV_2^2}{2} + mgz_2 \right) \\ &= \psi_1 - \psi_2 \end{aligned} \quad (8.27)$$

where ψ is called the availability function of a steady flow process given by

$$\psi = B + \frac{mV^2}{2} + mgz$$

On a unit mass basis,

$$W_{\max} = \left(h_1 - T_0 s_1 + \frac{V_1^2}{2} + gz_1 \right) - \left(h_2 - T_0 s_2 + \frac{V_2^2}{2} + gz_2 \right)$$

$$= \left(b_1 + \frac{V_1^2}{2} + gz_1 \right) - \left(b_2 + \frac{V_2^2}{2} + gz_2 \right) \quad (8.28)$$

If K.E. and P.E. changes are neglected, Eqs (8.27) and (8.28) reduce to

$$\begin{aligned} W_{\max} &= B_1 - B_2 \\ &= (H_1 - T_0 S_1) - (H_2 - T_0 S_2) \\ &= (H_1 - H_2) - T_0 (S_1 - S_2) \end{aligned} \quad (8.29)$$

and per unit mass

$$\begin{aligned} W_{\max} &= b_1 - b_2 \\ &= (h_1 - h_2) - T_0 (s_1 - s_2) \end{aligned} \quad (8.30)$$

8.5.2 Reversible Work in a Closed System

For a closed system,

$$dm_1 = dm_2 = 0$$

Equation (8.24) then becomes

$$\begin{aligned} dW_{\max} &= -d \left[U - T_0 S + \frac{m V^2}{2} + mgz \right]_{\sigma} \\ &= -d(E - T_0 S)_{\sigma} \end{aligned}$$

where

$$E = U + \frac{m V^2}{2} + mgz$$

For a change of state of the system from the initial state 1 to the final state 2,

$$\begin{aligned} W_{\max} &= E_1 - E_2 - T_0 (S_1 - S_2) \\ &= (E_1 - T_0 S_1) - (E_2 - T_0 S_2) \end{aligned} \quad (8.31)$$

If the K.E. and P.E. changes are neglected, Eq. (8.31) reduces to

$$W_{\max} = (U_1 - T_0 S_1) - (U_2 - T_0 S_2) \quad (8.32)$$

For unit mass of fluid,

$$\begin{aligned} W_{\max} &= (u_1 - u_2) - T_0 (s_1 - s_2) \\ &= (u_1 - T_0 s_1) - (u_2 - T_0 s_2) \end{aligned} \quad (8.33)$$

8.6 Useful Work

All of the work W of the system with a flexible boundary would not be available for delivery, since a certain portion of it would be spent in pushing out the atmosphere (Fig. 8.12). The useful work is defined as the actual work delivered by a system less the work performed on the atmosphere. If V_1 and V_2 are the initial and final volume of the system and p_0 is the atmospheric pressure, then the work done on the atmosphere is $p_0 (V_2 - V_1)$. Therefore, the useful work W_u becomes

$$W_u = W_{\text{act}} - p_0 (V_2 - V_1) \quad (8.34)$$

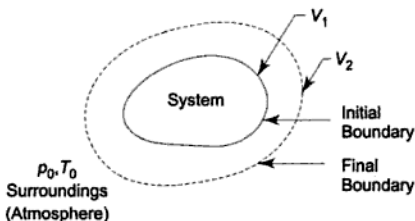

Fig. 8.12 Work done by a closed system in pushing out the atmosphere

Similarly, the *maximum useful work* will be

$$(W_u)_{\max} = W_{\max} - p_0 (V_2 - V_1) \quad (8.35)$$

In differential form

$$(dW_u)_{\max} = dW_{\max} - p_0 dV \quad (8.36)$$

In a steady flow system, the volume of the system does not change. Hence, the maximum useful work would remain the same, i.e., *no work is done on the atmosphere*, or

$$(dW_u)_{\max} = dW_{\max} \quad (8.37)$$

But in the case of an unsteady-flow open system or a closed system, the volume of the system changes. Hence, when a system exchanges heat only with the atmosphere, the maximum useful work becomes

$$(dW_u)_{\max} = dW_{\max} - p_0 dV$$

Substituting dW_{\max} from Eq. (8.24),

$$(dW_u)_{\max} = dm_1 \left(h_1 - T_0 s_1 + \frac{V_1^2}{2} + gz_1 \right) - dm_2 \left(h_2 - T_0 s_2 + \frac{V_2^2}{2} + gz_2 \right) - d \left[U + p_0 V - T_0 S + \frac{m V^2}{2} + mgz \right]_{\sigma} \quad (8.38)$$

This is the maximum useful work for an *unsteady open system*.

For the closed system, Eq. (8.38) reduces to

$$(dW_u)_{\max} = -d \left[U + p_0 V - T_0 S + \frac{m V^2}{2} + mgz \right]_{\sigma} = -d [E + p_0 V - T_0 S]_{\sigma} \quad (8.39)$$

$$\therefore (W_u)_{\max} = E_1 - E_2 + p_0 (V_1 - V_2) - T_0 (S_1 - S_2) \quad (8.40)$$

If K.E. and P.E. changes are neglected, Eq. (8.40) becomes

$$(W_u)_{\max} = U_1 - U_2 + p_0 (V_1 - V_2) - T_0 (S_1 - S_2) \quad (8.41)$$

This can also be written in the following form

$$(W_u)_{\max} = (U_1 + p_0 V_1 - T_0 S_1) - (U_2 + p_0 V_2 - T_0 S_2) \quad (8.42)$$

$$= \phi_1 - \phi_2$$

where ϕ is called the *availability function for a closed system* given by

$$\phi = U + p_0 V - T_0 S$$

The useful work per unit mass becomes

$$(W_u)_{\max} = (u_1 + p_0 v_1 - T_0 s_1) - (u_2 + p_0 v_2 - T_0 s_2) \quad (8.43)$$

8.6.1 Maximum Useful Work Obtainable when the System Exchanges Heat with a Thermal Reservoir in Addition to the Atmosphere

If the open system discussed in Sec. 8.5 exchanges heat with a thermal energy reservoir at temperature T_R in addition to the atmosphere, the *maximum useful*

work will be increased by $\delta Q_R \left(1 - \frac{T_0}{T_R}\right)$, where δQ_R is the heat received by the system. For a steady flow process,

$$\begin{aligned} (W_u)_{\max} = W_{\max} &= \left(H_1 - T_0 S_1 + \frac{m V_1^2}{2} + m g z_1 \right) \\ &\quad - \left(H_2 - T_0 S_2 + \frac{m V_2^2}{2} + m g z_2 \right) + Q_R \left(1 - \frac{T_0}{T_R} \right) \\ &= \psi_1 - \psi_2 + Q_R \left(1 - \frac{T_0}{T_R} \right) \end{aligned} \quad (8.44)$$

For a closed system

$$(W_u)_{\max} = W_{\max} - p_0 (V_2 - V_1) + Q_R \left(1 - \frac{T_0}{T_R} \right)$$

or
$$(W_u)_{\max} = E_1 - E_2 + p_0 (V_1 - V_2) - T_0 (S_1 - S_2) + Q_R \left(1 - \frac{T_0}{T_R} \right) \quad (8.45)$$

If K.E. and P.E. changes are neglected, then for a *steady flow process*:

$$(W_u)_{\max} = (H_1 - H_2) - T_0 (S_1 - S_2) + Q_R \left(1 - \frac{T_0}{T_R} \right) \quad (8.46)$$

and for a *closed system*:

$$(W_u)_{\max} = U_1 - U_2 + p_0 (V_1 - V_2) - T_0 (S_1 - S_2) + Q_R \left(1 - \frac{T_0}{T_R} \right) \quad (8.47)$$

8.7 Dead State

If the state of a system departs from that of the surroundings, an opportunity exists for producing work (Fig. 8.13). However, as the system changes its state

towards that of the surroundings, this opportunity diminishes, and it ceases to exist when the two are in equilibrium with each other. When the system is in equilibrium with the surroundings, it must be in pressure and temperature equilibrium with the surroundings, i.e., at p_0 and T_0 . It must also be in chemical equilibrium with the surroundings, i.e., there should not be any chemical reaction or mass transfer. The system must have zero velocity and minimum potential energy. This state of the system is known as the *dead state*, which is designated by affixing subscript '0' to the properties. Any change in the state of the system from the dead state is a measure of the available work that can be extracted from it. Farther the initial point of the system from the dead state in terms of p, t either above or below it, higher will be the available energy or exergy of the system (Fig. 8.13). All spontaneous processes terminate at the dead state.

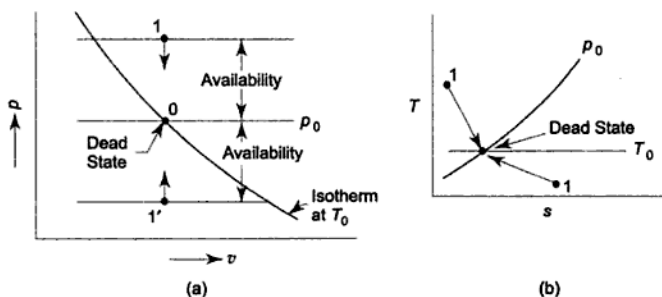

Fig. 8.13 Available work of a system decreases as its state approaches p_0, T_0

8.8 Availability

Whenever useful work is obtained during a process in which a finite system undergoes a change of state, the process must terminate when the pressure and temperature of the system have become equal to the pressure and temperature of the surroundings, p_0 and T_0 , i.e., when the system has reached the dead state. An air engine operating with compressed air taken from a cylinder will continue to deliver work till the pressure of air in the cylinder becomes equal to that of the surroundings, p_0 . A certain quantity of exhaust gases from an internal combustion engine used as the high temperature source of a heat engine will deliver work until the temperature of the gas becomes equal to that of the surroundings, T_0 .

The availability (A) of a given system is defined as *the maximum useful work (total work minus pdV work) that is obtainable in a process in which the system comes to equilibrium with its surroundings*. Availability is thus a composite property depending on the state of both the system and surroundings.

8.8.1 Availability in a Steady Flow Process

The reversible (maximum) work associated with a steady flow process for a single flow is given by Eq. (8.26)

$$W_{\text{rev}} = \left(H_1 - T_0 S_1 + \frac{m V_1^2}{2} + m g z_1 \right) - \left(H_2 - T_0 S_2 + \frac{m V_2^2}{2} + m g z_2 \right)$$

With a given state for the mass entering the control volume, the maximum useful work obtainable (i.e., the availability) would be when this mass leaves the control volume in equilibrium with the surroundings (i.e., at the dead state). Since there is no change in volume, no work will be done on the atmosphere. Let us designate the initial state of the mass entering the C.V. with parameters having *no subscript* and the final dead state of the mass leaving the C.V. with parameters having subscript 0. The maximum work or availability, A , would be

$$A = \left(H - T_0 S + \frac{m V^2}{2} + m g z \right) - (H_0 - T_0 S_0 + m g z_0) = \psi - \psi_0 \quad (8.48)$$

where ψ is called the *availability function for a steady flow system* and $V_0 = 0$. This is the availability of a system at any state as it enters a C.V. in a steady flow process. The availability per unit mass would be

$$a = \left(h - T_0 s + \frac{V^2}{2} + g z \right) - (h_0 - T_0 s_0 + g z) = \psi - \psi_0 \quad (8.49)$$

If subscripts 1 and 2 denote the states of a system entering and leaving a C.V., the decrease in availability or maximum work obtainable for the given system-surroundings combination would be

$$\begin{aligned} W_{\text{max}} &= a_1 - a_2 = \psi_1 - \psi_2 \\ &= \left[\left(h_1 - T_0 s_1 + \frac{V_1^2}{2} + g z_1 \right) - (h_0 - T_0 s_0 + g z_0) \right] \\ &\quad - \left[\left(h_2 - T_0 s_2 + \frac{V_2^2}{2} + g z_2 \right) - (h_0 - T_0 s_0 + g z_0) \right] \\ &= (h_1 - h_2) - T_0 (s_1 - s_2) + \frac{V_1^2 - V_2^2}{2} + g(z_1 - z_2) \end{aligned} \quad (8.50)$$

If K.E. and P.E. changes are neglected,

$$\begin{aligned} W_{\text{max}} &= (h_1 - T_0 s_1) - (h_2 - T_0 s_2) \\ &= b_1 - b_2 \end{aligned}$$

where b is the specific Keenan function.

If more than one flow into and out of the C.V. is involved.

$$W_{\text{max}} = \sum_i m_i \psi_i - \sum_e m_e \psi_e$$

8.8.2 Availability in a Nonflow Process

Let us consider a closed system and denote its initial state by parameters without any subscript and the final dead state with subscript '0'. The availability of the system A , i.e., the maximum useful work obtainable as the system reaches the dead state, is given by Eq. (8.40).

$$\begin{aligned}
 A &= (W_u)_{\max} = E - E_0 + p_0(V - V_0) - T_0(S - S_0) \\
 &= \left(U + \frac{mV^2}{2} + mgz \right) - (U_0 + mgz_0) + p_0(V - V_0) - T_0(S - S_0) \quad (8.51)
 \end{aligned}$$

If K.E. and P.E. changes are neglected and for unit mass, the availability becomes

$$\begin{aligned}
 a &= u - u_0 + p_0(v - v_0) - T_0(s - s_0) \\
 &= (u + p_0v - T_0s) - (u_0 + p_0v_0 - T_0s_0) \\
 &= \phi - \phi_0 \quad (8.52)
 \end{aligned}$$

where ϕ is the availability function of the closed system.

If the system undergoes a change of state from 1 to 2, the decrease in availability will be

$$\begin{aligned}
 a &= (\phi_1 - \phi_0) - (\phi_2 - \phi_0) \\
 &= \phi_1 - \phi_2 \\
 &= (u_1 - u_2) + p_0(v_1 - v_2) - T_0(s_1 - s_2) \quad (8.53)
 \end{aligned}$$

This is the maximum useful work obtainable under the given surroundings.

8.9 Availability in Chemical Reactions

In many chemical reactions the reactants are often in pressure and temperature equilibrium with the surroundings (before the reaction takes place) and so are the products after the reaction. An internal combustion engine can be cited as an example of such a process if we visualize the products being cooled to atmospheric temperature T_0 before being discharged from the engine.

(a) Let us first consider a system which is in temperature equilibrium with the surroundings before and after the process. The maximum work obtainable during a change of state is given by Eq. (8.31),

$$\begin{aligned}
 W_{\max} &= E_1 - E_2 - T_0(S_1 - S_2) \\
 &= \left(U_1 + \frac{mV_1^2}{2} + mgz_1 \right) - \left(U_2 + \frac{mV_2^2}{2} + mgz_2 \right) - T_0(S_1 - S_2)
 \end{aligned}$$

If K.E. and P.E. changes are neglected,

$$W_{\max} = U_1 - U_2 - T_0(S_1 - S_2)$$

Since the initial and final temperatures of the system are the same as that of the surroundings, $T_1 = T_2 = T_0 = T$, say, then

$$(W_T)_{\max} = (U_1 - U_2)_T - T(S_1 - S_2)_T \quad (8.54)$$

Let a property called *Helmholtz function* F be defined by the relation

$$F = U - TS \quad (8.55)$$

Then for two equilibrium states 1 and 2 at the same temperature T ,

$$(F_1 - F_2)_T = (U_1 - U_2)_T - T(S_1 - S_2)_T \quad (8.56)$$

From Eqs (8.54) and (8.56),

$$(W_T)_{\max} = (F_1 - F_2)_T \quad (8.57)$$

$$\text{or} \quad W_T \leq (F_1 - F_2)_T \quad (8.58)$$

The work done by a system in any process between two equilibrium states at the same temperature during which the system exchanges heat only with the environment is equal to or less than the decrease in the Helmholtz function of the system during the process. The maximum work is done when the process is reversible and the equality sign holds. If the process is irreversible, the work is less than the maximum.

(b) Let us now consider a system which is in both pressure and temperature equilibrium with the surroundings before and after the process. When the volume of the system increases some work is done by the system against the surroundings (pdV work), and this is not available for doing useful work. The availability of the system, as defined by Eq. (8.51), neglecting the K.E. and P.E. changes, can be expressed in the form

$$\begin{aligned} A = (W_u)_{\max} &= (U + p_0V - T_0S) - (U_0 + p_0V_0 - T_0S_0) \\ &= \phi - \phi_0 \end{aligned}$$

The maximum work obtainable during a change of state is the decrease in availability of the system, as given by Eq.(8.53) for unit mass.

$$\begin{aligned} \therefore (W_u)_{\max} &= A_1 - A_2 = \phi_1 - \phi_2 \\ &= (U_1 - U_2) + p_0(V_1 - V_2) - T_0(S_1 - S_2) \end{aligned}$$

If the initial and final equilibrium states of the system are at the same pressure and temperature of the surroundings, say $p_1 = p_2 = p_0 = p$, and $T_1 = T_2 = T_0 = T$. Then,

$$(W_u)_{\max} = (U_1 - U_2)_{p, T} + p(V_1 - V_2)_{p, T} - T(S_1 - S_2)_{p, T} \quad (8.59)$$

The *Gibbs functions* G is defined as

$$\begin{aligned} G &= H - TS \\ &= U + pV - TS \end{aligned} \quad (8.60)$$

Then for two equilibrium states at the same pressure p and temperature T

$$(G_1 - G_2)_{p, T} = (U_1 - U_2)_{p, T} + p(V_1 - V_2)_{p, T} - T(S_1 - S_2)_{p, T} \quad (8.61)$$

From Eqs (8.59) and (8.61)

$$(W_u)_{\max} = (G_1 - G_2)_{p, T} \quad (8.62)$$

$$\therefore (W_u)_{p, T} \leq (G_1 - G_2)_{p, T} \quad (8.63)$$

The decrease in the Gibbs function of a system sets an upper limit to the work that can be performed, exclusive of pdV work, in any process between two equilibrium states at the same temperature and pressure, provided the system exchanges heat only with the environment which is at the same temperature and pressure as the end states of the system. If the process is irreversible, the useful work is less than the maximum.

8.10 Irreversibility and Gouy-Stodola Theorem

The actual work done by a system is always less than the idealized reversible work, and the difference between the two is called the irreversibility of the process.

$$I = W_{\max} - W \quad (8.64)$$

This is also sometimes referred to as 'degradation' or 'dissipation'.

For a non-flow process between the equilibrium states, when the system exchanges heat only with the environment

$$\begin{aligned} I &= [(U_1 - U_2) - T_0(S_1 - S_2)] - [(U_1 - U_2) + Q] \\ &= T_0(S_2 - S_1) - Q \\ &= T_0(\Delta S)_{\text{system}} + T_0(\Delta S)_{\text{surr}} \\ &= T_0[(\Delta S)_{\text{system}} + (\Delta S)_{\text{surr}}] \end{aligned} \quad (8.65)$$

$$\therefore I \geq 0$$

Similarly, for the steady flow process

$$\begin{aligned} I &= W_{\max} - W \\ &= \left[\left(B_1 + \frac{mV_1^2}{2} + mgZ_1 \right) - \left(B_2 + \frac{mV_2^2}{2} + mgZ_2 \right) \right] \\ &\quad - \left[\left(H_1 + \frac{mV_1^2}{2} + mgZ_1 \right) - \left(H_2 + \frac{mV_2^2}{2} + mgZ_2 \right) + Q \right] \\ &= T_0(S_2 - S_1) - Q \\ &= T_0(\Delta S)_{\text{system}} + T_0(\Delta S)_{\text{surr}} \\ &= T_0(\Delta S)_{\text{system}} + S_{\text{surr}} = T_0\Delta S_{\text{univ}} \end{aligned} \quad (8.66)$$

The same expression for irreversibility applies to both flow and non-flow processes. The quantity $T_0(\Delta S)_{\text{system}} + \Delta S_{\text{surr}}$ represents an increase in unavailable energy (or energy).

The *Gouy-Stodola theorem* states that the rate of loss of available energy or exergy in a process is proportional to the rate of entropy generation, S_{gen} . If Eqs (8.65) and (8.66) are written in the rate form,

$$\dot{I} = \dot{W}_{\text{lost}} = T_0\dot{\Delta S}_{\text{univ}} = T_0\dot{S}_{\text{gen}} \quad (8.67)$$

This is known as the Gouy-Stodola equation. A thermodynamically efficient process would involve minimum exergy loss with minimum rate of entropy generation.

8.10.1 Applications of Gouy-Stodola Equation

(a) **Heat Transfer through a Finite Temperature Difference** If heat transfer \dot{Q} occurs from the hot reservoir at temperature T_1 to the cold reservoir at temperature T_2 (Fig. 8.14a)

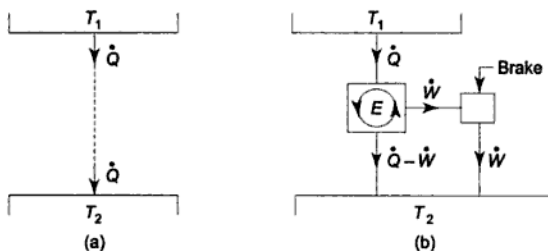

Fig. 8.14 Destruction of available work or exergy by heat transfer through a finite temperature difference

$$S_{\text{gen}} = \frac{\dot{Q}}{T_2} - \frac{\dot{Q}}{T_1} = \dot{Q} \frac{T_1 - T_2}{T_1 T_2}$$

and

$$\dot{W}_{\text{lost}} = \dot{Q} \left(1 - \frac{T_2}{T_1} \right) = \dot{Q} \frac{T_1 - T_2}{T_1}$$

\therefore

$$\dot{W}_{\text{lost}} = T_2 S_{\text{gen}}$$

If the heat transfer \dot{Q} from T_1 to T_2 takes place through a reversible engine E , the entire work output \dot{W} is dissipated in the brake, from which an equal amount of heat is rejected to the reservoir at T_2 (Fig. 8.14b). Heat transfer through a finite temperature difference is equivalent to the destruction of its exergy.

(b) Flow with Friction Let us consider the steady and adiabatic flow of an ideal gas through the segment of a pipe (Fig. 8.15a).

By the first law,

$$h_1 = h_2$$

and by the second law,

$$T ds = dh \text{ vdp}$$

$$\int_1^2 ds = \int_1^2 \frac{dh}{T} - \int_1^2 \frac{v}{T} dp = - \int_1^2 \frac{v}{T} dp$$

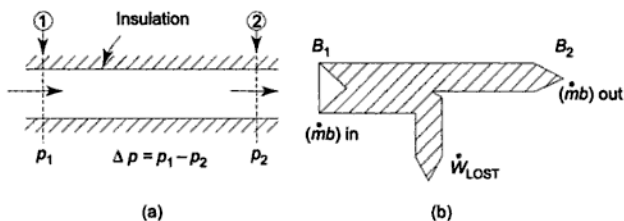

Fig. 8.15 Irreversibility in a duct due to fluid friction

$$\begin{aligned}
 \therefore \dot{S}_{\text{gen}} &= \int_1^2 \dot{m} ds = - \int_{p_1}^{p_2} \dot{m} R \frac{dp}{p} = -\dot{m} R \ln \frac{p_2}{p_1} \\
 &= -\dot{m} R \ln \left(1 - \frac{\Delta p}{p_1} \right) = -\dot{m} R \left(-\frac{\Delta p}{p_1} \right) \\
 &= \dot{m} R \frac{\Delta p}{p_1} \qquad (8.68)
 \end{aligned}$$

where $\ln \left(1 - \frac{\Delta p}{p_1} \right) \cong -\frac{\Delta p}{p_1}$, since $\frac{\Delta p}{p_1} < 1$

and higher terms are neglected.

$$\begin{aligned}
 \dot{W}_{\text{lost}} &= \dot{B}_1 - \dot{B}_2 \\
 &= \dot{m} [(h_1 - T_0 s_1) - (h_2 - T_0 s_2)] \\
 &= \dot{m} T_0 (s_2 - s_1) \\
 &= T_0 \dot{S}_{\text{gen}} = \dot{m} R T_0 \frac{\Delta p}{p_1} \qquad (8.69)
 \end{aligned}$$

The decrease in availability or lost work is proportional to the pressure drop (Δp) and the mass flow rate (\dot{m}). It is shown on the right (Fig. 8.15b) by the *Grassmann diagram*, the width being proportional to the availability (or exergy) of the stream. It is an adaptation of the *Sankey diagram* used for energy transfer in a plant.

(c) Mixing of Two Fluids Two streams 1 and 2 of an incompressible fluid or an ideal gas mix adiabatically at constant pressure (Fig. 8.16).

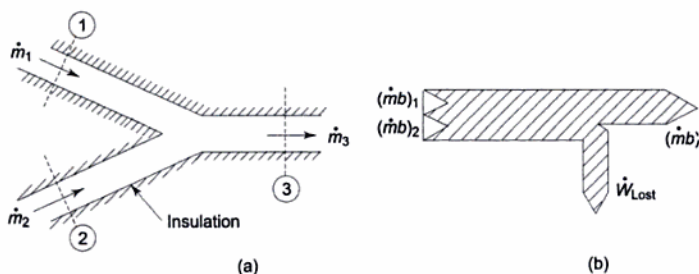

Fig. 8.16 Irreversibility due to mixing

Here, $\dot{m}_1 + \dot{m}_2 = \dot{m}_3 = \dot{m}$ (say)

Let $x = \frac{\dot{m}_1}{\dot{m}_1 + \dot{m}_2}$

By the first law,

$$\begin{aligned}\dot{m}_1 h_1 + \dot{m}_2 h_2 &= (\dot{m}_1 + \dot{m}_2) h_3 \\ \text{or} \quad x h_1 + (1-x) h_2 &= h_3\end{aligned}$$

The preceding equation may be written in the following form, since enthalpy is a function of temperature.

$$x T_1 + (1-x) T_2 = T_3$$

$$\therefore \frac{T_3}{T_1} = x + (1-x)\tau \quad (8.70)$$

where
$$\tau = \frac{T_2}{T_1}$$

By the second law,

$$\begin{aligned}\dot{S}_{\text{gen}} &= \dot{m}_3 s_3 - \dot{m}_1 s_1 - \dot{m}_2 s_2 \\ &= \dot{m} s_3 - x \dot{m} s_1 - (1-x) \dot{m} s_2\end{aligned}$$

$$\begin{aligned}\therefore \frac{\dot{S}_{\text{gen}}}{\dot{m}} &= (s_3 - s_2) + x(s_2 - s_1) \\ &= c_p \ln \frac{T_3}{T_1} + x c_p \ln \frac{T_2}{T_1}\end{aligned}$$

or
$$\frac{\dot{S}_{\text{gen}}}{\dot{m} c_p} = \ln \left(\frac{T_3}{T_2} \right) \left(\frac{T_2}{T_1} \right)^x$$

or
$$N_s = \ln \left(\frac{T_3}{T_1} \right) \frac{T_1^{1-x}}{T_2^{1-x}}$$

or
$$N_s = \ln \frac{T_3/T_1}{(T_2/T_1)^{1-x}} \quad (8.71)$$

where N_s is a dimensionless quantity, called the *entropy generation number*, given by $\dot{S}_{\text{gen}}/\dot{m} c_p$.

Substituting T_3/T_1 from Eq. (8.70) in Eq. (8.71),

$$N_s = \ln \frac{x + \tau(1-x)}{\tau^{1-x}} \quad (8.72)$$

If $x = 1$ or $\tau = 1$, N_s becomes zero in each case. The magnitude of N_s depends on x and τ . The rate of loss of energy due to mixing would be

$$\dot{W}_{\text{lost}} = \dot{I} = T_0 \dot{m} c_p \ln \frac{x + \tau(1-x)}{\tau^{1-x}} \quad (8.73)$$

8.11 Availability or Exergy Balance

The availability or exergy is the maximum useful work obtainable from a system as it reaches the dead state (p_0, t_0). Conversely, availability or exergy can be

regarded as the minimum work required to bring the closed system from the dead state to the given state. The value of exergy cannot be negative. If a closed system were at any state other than the dead state, the system would be able to change its state spontaneously toward the dead state. This tendency would stop when the dead state is reached. No work is done to effect such a spontaneous change. Since any change in state of the closed system to the dead state can be accomplished with zero work, the *maximum work (or exergy) cannot be negative*.

While energy is always conserved, exergy is not generally conserved, but is destroyed by irreversibilities. When the closed system is allowed to undergo a spontaneous change from the given state to the dead state, its exergy is completely destroyed without producing any useful work. The potential to develop work that exists originally at the given state is thus completely wasted in such a spontaneous process. Therefore, at steady state:

1. Energy in – Energy out = 0
2. Exergy in – Exergy out = Exergy destroyed

8.11.1 Exergy Balance for a Closed System

For a closed system, availability or exergy transfer occurs through heat and work interactions (Fig. 8.17).

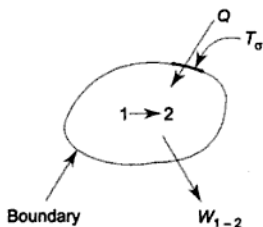

Fig. 8.17 Exergy balance for a closed system

$$\text{1st law:} \quad E_2 - E_1 = \int_1^2 \delta Q - W_{1-2} \quad (8.74)$$

$$\text{2nd law:} \quad S_2 - S_1 - \int_1^2 \left[\frac{\delta Q}{T} \right] = S_{\text{gen}}$$

$$\text{or} \quad T_0(S_2 - S_1) - T_0 \int_1^2 \left[\frac{\delta Q}{T} \right]_{\sigma} = T_0 S_{\text{gen}} \quad (8.75)$$

Subtracting Eq. (8.75) from Eq. (8.74),

$$E_2 - E_1 - T_0(S_2 - S_1) = \int_1^2 \delta Q - W_{1-2} - T_0 \int_1^2 \left[\frac{\delta Q}{T} \right] - T_0 S_{\text{gen}}$$

$$= \int_1^2 \left[1 - \frac{T_0}{T_\sigma} \right] dQ - W_{1-2} - T_0 S_{\text{gen}}$$

Since,

$$A_2 - A_1 = E_2 - E_1 + p_0(V_2 - V_1) - T_0(S_2 - S_1)$$

$$A_2 - A_1 = \int_1^2 \left(1 - \frac{T_0}{T_\sigma} \right) dQ - [W_{1-2} - p_0(V_2 - V_1)] - T_0 S_{\text{gen}} \quad (8.76)$$

Change in exergy Exergy transfer with heat Exergy transfer with work Exergy destruction

In the form of the rate equation,

$$\frac{dA}{d\tau} = \sum_j \left[1 - \frac{T_0}{T_j} \right] \dot{Q}_j - \left[W - p_0 \frac{dV}{d\tau} \right] - \dot{I} \quad (8.77)$$

Rate of change of exergy Rate of exergy transfer with heat \dot{Q}_j at the boundary where the instantaneous temperature is T_j Rate of exergy transfer as work where $dV/d\tau$ is the rate of change of system volume Rate of exergy loss due to irreversibilities ($= T_0 \dot{S}_{\text{gen}}$)

For an isolated system, the exergy balance, Eq. (8.77), gives

$$\Delta A = -I \quad (8.78)$$

Since $I > 0$, the only processes allowed by the second law are those for which the exergy of the isolated system decreases. In other words,

The exergy of an isolated system can never increase.

It is the counterpart of the entropy principle which states that the entropy of an isolated system can never decrease.

The exergy balance of a system can be used to determine the locations, types and magnitudes of losses (waste) of the potential of energy resources (fuels) and find ways and means to reduce these losses for making the system more energy efficient and for more effective use of fuel.

8.11.2 Exergy Balance for a Steady Flow System

$$\begin{aligned} \text{1st law:} \quad H_1 + \frac{mV_1^2}{2} + mgZ_1 + Q_{1-2} \\ = H_2 + \frac{mV_2^2}{2} + mgZ_2 + W_{1-2} \end{aligned} \quad (8.78)$$

$$\text{2nd law:} \quad S_1 + \int_1^2 \left(\frac{dQ}{T} \right) - S_2 = S_{\text{gen}}$$

$$\text{or} \quad T_0(S_1 - S_2) + T_0 \int_1^2 \left(\frac{dQ}{T} \right)_\sigma = T_0 S_{\text{gen}} = I \quad (8.79)$$

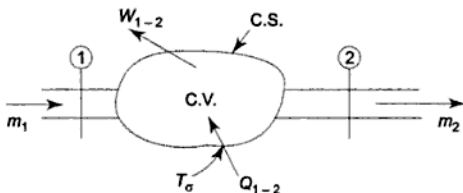

Fig. 8.18 Exergy balance for a steady flow system

From Eqs (8.78) and (8.79),

$$\begin{aligned}
 H_2 - H_1 - T_0(S_2 - S_1) + m \frac{V_2^2 - V_1^2}{2} + mg(Z_2 - Z_1) \\
 = \int_1^2 \left(1 - \frac{T_0}{T_\sigma}\right) dQ - W_{1-2} - I
 \end{aligned} \quad (8.80)$$

or

$$A_2 - A_1 = \int_1^2 \left(1 - \frac{T_0}{T_\sigma}\right) dQ - W_{1-2} - I \quad (8.81)$$

In the form of rate equation at steady state:

$$\sum_j \left(1 - \frac{T_0}{T_j}\right) \dot{Q}_j - \dot{W}_{C.V.} + \dot{m}(a_{f_1} - a_{f_2}) - \dot{I}_{C.V.} = 0 \quad (8.82)$$

where $a_{f_1} - a_{f_2} = (h_1 - h_2) - T_0(s_1 - s_2) + \frac{V_1^2 - V_2^2}{2} + g(Z_1 - Z_2)$ and $[1 - T_0/T_j] \dot{Q}_j$ = time rate of exergy transfer along with heat \dot{Q}_j occurring at the location on the boundary where the instantaneous temperature is T_j .

For a single stream entering and leaving, the exergy balance gives

$$\left[1 - \frac{T_0}{T_\sigma}\right] \frac{\dot{Q}}{\dot{m}} + a_{f_1} - \frac{\dot{W}}{\dot{m}} - a_{f_2} = \frac{\dot{I}}{\dot{m}} \quad (8.83)$$

Exergy in Exergy out Exergy loss

8.12 Second Law Efficiency

A common measure on energy use efficiency is the first law efficiency, η_1 . The first law efficiency is defined as the ratio of the output energy of a device to the input energy of the device. The first law is concerned only with the quantities of energy, and disregards the forms in which the energy exists. It does not also discriminate between the energies available at different temperatures. It is the second law of thermodynamics which provides a means of assigning a quality index to energy. The concept of available energy or exergy provides a useful measure of energy quality (Sec. 8.3).

With this concept it is possible to analyze means of minimizing the consumption of available energy to perform a given process, thereby ensuring the most efficient possible conversion of energy for the required task.

The second law efficiency, η_{II} , of a process is defined as the ratio of the minimum available energy (or exergy) which must be consumed to do a task divided by the actual amount of available energy (or exergy) consumed in performing the task.

$$\eta_{II} = \frac{\text{minimum exergy intake to perform the given task}}{\text{actual exergy intake to perform the same task}}$$

$$\text{or } \eta_{II} = \frac{A_{\min}}{A} \quad (8.84)$$

where A is the availability or exergy.

A power plant converts a fraction of available energy A or W_{\max} to useful work W . For the desired output of W , $A_{\min} = W$ and $A = W_{\max}$. Here,

$$I = W_{\max} - W \text{ and } \eta_{II} = \frac{W}{W_{\max}} \quad (8.85)$$

Now

$$\begin{aligned} \eta_{II} &= \frac{W}{Q_1} = \frac{W}{W_{\max}} \cdot \frac{W_{\max}}{Q_1} \\ &= \eta_{II} \cdot \eta_{\text{Carnot}} \end{aligned} \quad (8.86)$$

$$\therefore \eta_{II} = \frac{\eta_{II}}{\eta_{\text{Carnot}}} \quad (8.87)$$

Since $W_{\max} = Q_1 \left(1 - \frac{T_0}{T}\right)$, Eq. (8.87) can also be obtained directly as follows

$$\eta_{II} = \frac{W}{Q_1 \left(1 - \frac{T_0}{T}\right)} = \frac{\eta_{II}}{\eta_{\text{Carnot}}}$$

If work is involved, $A_{\min} = W$ (desired) and if heat is involved, $A_{\min} = Q \left(1 - \frac{T_0}{T}\right)$.

If solar energy Q_r is available at a reservoir storage temperature T_r and if quantity of heat Q_a is transferred by the solar collector at temperature T_a , then

$$\eta_{II} = \frac{Q_a}{Q_r}$$

and

$$\eta_{II} = \frac{\text{exergy output}}{\text{exergy input}}$$

$$\begin{aligned}
 &= \frac{Q_a \left(1 - \frac{T_0}{T_a}\right)}{Q_r \left(1 - \frac{T_0}{T_r}\right)} \\
 &= \eta_{II} \frac{1 - \frac{T_0}{T_a}}{1 - \frac{T_0}{T_r}} \quad (8.88)
 \end{aligned}$$

Table 8.1 shows availabilities, and both η_I and η_{II} expressions for several common thermal tasks.

Table 8.1 $T_p > T_a > T_0 > T_r$

Task	Energy input	
	Input shaft work, W_i	Q_r from reservoir at T_r
Produce work, W_0	$A = W_i$	$A = Q_r \left(1 - \frac{T_0}{T_r}\right)$
	$A_{\min} = W_0$	$A_{\min} = W_0$
	$\eta_I = \frac{W_0}{W_i}$	$\eta_I = \frac{W_0}{Q_r}$
	$\eta_{II} = \frac{A_{\min}}{A}$	$\eta_{II} = \eta_I \cdot \frac{1}{1 - \frac{T_0}{T_r}}$
	$\eta_{II} = \eta_I$ (electric motor)	(heat engine)
Add heat Q_a to reservoir at T_a	$A = W_i$	$A = Q_r \left(1 - \frac{T_0}{T_r}\right)$
	$A_{\min} = Q_a \left(1 - \frac{T_0}{T_a}\right)$	$A_{\min} = Q_a \left(1 - \frac{T_0}{T_a}\right)$
	$*\eta_I = \frac{Q_a}{W_i}$	$\eta_I = \frac{Q_a}{Q_r}$
	$*\eta_{II} = \eta_I \left(1 - \frac{T_0}{T_a}\right)$	$\eta_{II} = \eta_I \frac{1 - \frac{T_0}{T_a}}{1 - \frac{T_0}{T_r}}$
	(heat pump)	(solar water heater)

Extract heat Q_c from cold reservoir at T_c (below ambient)

$$A = W_i$$

$$A = Q_r \left(1 - \frac{T_0}{T_r} \right)$$

ambient)

$$A_{\min} = Q_c \left(\frac{T_0}{T_c} - 1 \right)$$

$$A_{\min} = Q_c \left(\frac{T_0}{T_c} - 1 \right)$$

$$*\eta_I = \frac{Q_c}{W_i}$$

$$*\eta_I = \frac{Q_c}{Q_r}$$

$$*\eta_{II} = \eta_I \left(\frac{T_0}{T_c} - 1 \right)$$

$$*\eta_{II} = \eta_I \left[\frac{\frac{T_0}{T_c} - 1}{1 - \frac{T_0}{T_r}} \right]$$

(Refrigerator-electric motor driven)

(Refrigerator-heat operated)

*Strictly speaking, it is COP.

In the case of a heat pump, the task is to add heat Q_a to a reservoir to be maintained at temperature T_a and the input shaft work is W_i .

$$\text{COP} = \frac{Q_a}{W_i} = \eta_{II}, \text{ say}$$

$$(\text{COP})_{\max} = \frac{T_a}{T_a - T_0} = \frac{Q_a}{W_i} = \frac{Q_a}{A_{\min}}$$

$$\therefore A_{\min} = Q_a \left(1 - \frac{T_0}{T_a} \right)$$

$$\therefore \eta_{II} = \frac{A_{\min}}{A} = \frac{Q_a \left(1 - \frac{T_0}{T_a} \right)}{W_i}$$

$$\eta_{II} = \eta_I \left(1 - \frac{T_0}{T_a} \right) \quad (8.89)$$

Similarly, expressions of η_I and η_{II} can be obtained for other thermal tasks.

8.12.1 Matching End Use to Source

Combustion of a fuel releases the necessary energy for the tasks, such as space heating, process steam generation and heating in industrial furnaces. When the products of combustion are at a temperature much greater than that required by a given task, the end use is not well matched to the source and results in inefficient utilization of the fuel burned. To illustrate this, let us consider a closed system receiving a heat transfer \dot{Q}_r at a source temperature T_r and delivering \dot{Q}_a at a use

temperature T_a (Fig. 8.19). Energy is lost to the surroundings by heat transfer at a rate \dot{Q}_l across a portion of the surface at T_l . At steady state the energy and availability rate balances become.

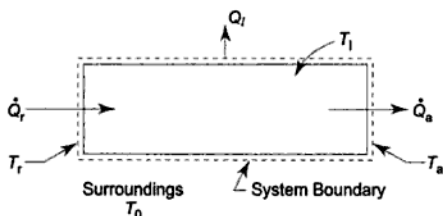

Fig. 8.19 Efficient energy utilization from second law viewpoint

$$\dot{Q}_r = \dot{Q}_a + \dot{Q}_l \quad (8.90)$$

$$\dot{Q}_r \left(1 - \frac{T_0}{T_r}\right) = \dot{Q}_a \left(1 - \frac{T_0}{T_a}\right) + \dot{Q}_l \left(1 - \frac{T_0}{T_l}\right) + j \quad (8.91)$$

Equation (8.90) indicates that the energy carried in by heat transfer \dot{Q}_r is either used, \dot{Q}_a , or lost to the surroundings, \dot{Q}_l . Then

$$\eta_I = \frac{\dot{Q}_a}{\dot{Q}_r} \quad (8.92)$$

The value of η_I can be increased by increasing insulation to reduce the loss. The limiting value, when $\dot{Q}_l = 0$, is $\eta_I = 1$ (100%).

Equation (8.91) shows that the availability or exergy carried from the system accompanying the heat transfer \dot{Q}_r is either transferred from the system accompanying the heat transfers \dot{Q}_a and \dot{Q}_l or destroyed by irreversibilities within the system, j . Therefore,

$$\eta_{II} = \frac{\dot{Q}_a \left(1 - \frac{T_0}{T_a}\right)}{\dot{Q}_r \left(1 - \frac{T_0}{T_r}\right)} = \eta_I \frac{1 - \frac{T_0}{T_a}}{1 - \frac{T_0}{T_r}} \quad (8.93)$$

Both η_I and η_{II} indicate how effectively the input is converted into the product. The parameter η_I does this on energy basis, whereas η_{II} does it on an availability or exergy basis.

For proper utilization of exergy, it is desirable to make η_I as close to unity as practical and also a good match between the source and use temperatures, T_r and T_a . Figure 8.20 demonstrates the second law efficiency against the use temperature T_a for an assumed source temperature $T_r = 2200$ K. It shows that η_{II} tends to unity (100%) as T_a approaches T_r . The lower the T_a , the lower becomes the value of η_{II} . Efficiencies for three applications, viz., space heating at $T_a = 320$ K, proc-

ess steam generation at $T_a = 480\text{K}$, and heating in industrial furnaces at $T_a = 700\text{K}$, are indicated on the figure. It suggests that fuel is used far more effectively in the high temperature use. An excessive temperatures gap between T_r and T_a causes a low η_{II} and an inefficient energy utilization. A fuel or any energy source is consumed efficiently when the first user temperature approaches the fuel temperature. This means that the fuel should first be used for high temperature applications. The heat rejected from these applications can then be cascaded to applications at lower temperatures, eventually to the task of, say, keeping a building warm. This is called *energy cascading* and ensures more efficient energy utilization.

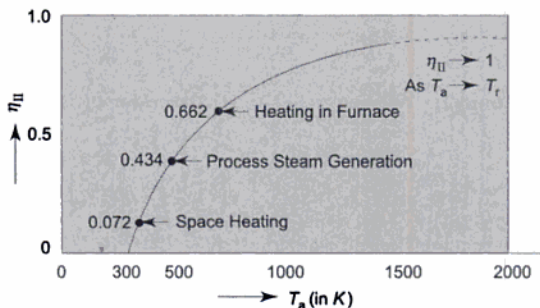

Fig. 8.20 Effect of use temperature T_a on the second law efficiency ($T_r = 2200\text{K}$, $T_0 = 300\text{K}$, $n_1 = 100\%$)

8.12.2 Further Illustrations of Second Law Efficiencies

Second law efficiency of different components can be expressed in different forms. It is derived by using the exergy balance rate, as given below:

(a) **Turbines** The steady state exergy balance (Fig. 8.21) gives:

$$\frac{\dot{Q}}{\dot{m}} \left[1 - \frac{T_0}{T_\sigma} \right] + a_{f1} = \frac{\dot{W}}{\dot{m}} + a_{f2} + \frac{\dot{I}}{\dot{m}}$$

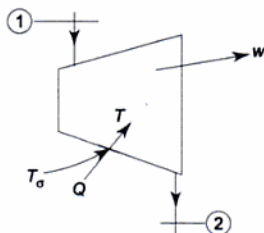

Fig. 8.21 Exergy balance of a turbine

If there is not heat loss,

$$a_{f_1} - a_{f_2} = \frac{\dot{W}}{\dot{m}} + \frac{\dot{i}}{\dot{m}} \quad (8.94)$$

The second law efficiency, $\eta_{II} = \frac{\dot{W}/\dot{m}}{a_{f_1} - a_{f_2}}$ (8.95)

(b) Compressor and Pump Similarly, for a compressor or a pump,

$$-\frac{\dot{W}}{\dot{m}} = a_{f_2} - a_{f_1} + \frac{\dot{i}}{\dot{m}}$$

and $\eta_{II} = \frac{a_{f_2} - a_{f_1}}{-\dot{W}/\dot{m}}$ (8.96)

(c) Heat Exchanger Writing the exergy balance for the heat exchanger, (Fig. 8.22)

$$\sum \left[1 - \frac{T_0}{T_j} \right] \dot{Q}_j - \dot{W}_{C.V.} + [\dot{m}_h a_{f_1} + \dot{m}_c a_{f_3}] - [\dot{m}_h a_{f_2} + \dot{m}_c a_{f_4}] - \dot{i}_{C.V.} = 0$$

If there is no heat transfer and work transfer,

$$\dot{m}_h [a_{f_1} - a_{f_2}] = \dot{m}_c [a_{f_4} - a_{f_3}] + \dot{i} \quad (8.97)$$

$$\eta_{II} = \frac{\dot{m}_c [a_{f_4} - a_{f_3}]}{\dot{m}_h [a_{f_1} - a_{f_2}]} \quad (8.98)$$

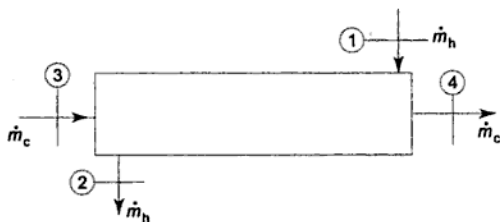

Fig. 8.22 Exergy balance of a heat exchanger

(d) Mixing of Two Fluids Exergy balance for the mixer (Fig. 8.23) gives:

$$\left[1 - \frac{T_0}{T_\sigma} \right] \dot{Q} + \dot{m}_1 a_{f_1} + \dot{m}_2 a_{f_2} = \dot{W}_{C.V.} + \dot{m}_3 a_{f_3} + \dot{i}_{C.V.}$$

If the mixing is adiabatic and since $\dot{W}_{C.V.} = 0$ and $\dot{m}_1 + \dot{m}_2 = \dot{m}_3$,

$$\dot{m}_1 [a_{f_1} - a_{f_3}] = \dot{m}_2 [a_{f_3} - a_{f_2}] + \dot{i} \quad (8.99)$$

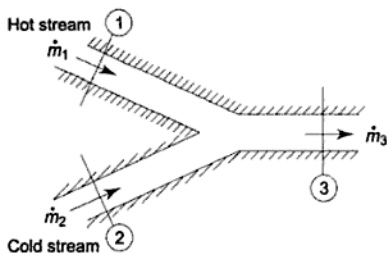

Fig. 8.23 Exergy loss due to mixing

and

$$\eta_{II} = \frac{\dot{m}_2 [a_{f_3} - a_{f_2}]}{\dot{m}_1 [a_{f_1} - a_{f_3}]} \quad (8.100)$$

8.13 Comments on Exergy

The energy of the universe, like its mass, is constant. Yet at times, we are bombarded with speeches and articles on how to “conserve” energy. As engineers, we know that energy is always conserved. What is not conserved is the exergy, i.e., the useful work potential of the energy. Once the exergy is wasted, it can never be recovered. When we use energy (electricity) to heat our homes, we are not destroying any energy, we are merely converting it to a less useful form, a form of less exergy value.

The maximum useful work potential of a system at the specified state is called exergy which is a composite property depending on the state of the system and the surroundings. A system which is in equilibrium with its surroundings is said to be at the dead state having zero exergy.

The mechanical forms of energy such as KE and PE are entirely available energy or exergy. The exergy (W) of thermal energy (Q) of reservoirs (TER) is equivalent to the work output of a Carnot heat engine operating between the reservoir at temperature T and environment at T_0 , i.e., $W = Q \left[1 - \frac{T_0}{T} \right]$.

The actual work W during a process can be determined from the first law. If the volume of the system changes during a process, part of this work (W_{surr}) is used to push the surrounding medium at constant pressure p_0 and it cannot be used for any useful purpose. The difference between the actual work and the surrounding work is called *useful work*, W_u

$$W_u = W - W_{\text{surr}} = W - p_0(V_2 - V_1)$$

W_{surr} is zero for cyclic devices, for steady flow devices, and for system with fixed boundaries (rigid walls).

The maximum amount of useful work that can be obtained from a system as it undergoes a process between two specified states is called *reversible work*, W_{rev} . If the final state of the system is the dead state, the reversible work and the exergy become identical.

The difference between the reversible work and useful work for a process is called *irreversibility*.

$$I = W_{rev} - W_u = T_0 S_{gen}$$

$$\dot{I} = T_0 \dot{S}_{gen}$$

For a total reversible process, $W_{rev} = W_u$ and $I = 0$.

The first law efficiency alone is not a realistic measure of performance for engineering devices. Consider two heat engines, having e.g., a thermal efficiency of, say, 30%. One of the engines (*A*) is supplied with heat Q from a source at 600 K and the other engine (*B*) is supplied with the same amount of heat Q from a source at 1000 K. Both the engines reject heat to the surroundings at 300 K.

$$(W_A)_{rev} = Q \left(1 - \frac{300}{600} \right) = 0.5Q, \text{ while } (W_A)_{act} = 0.3Q$$

Similarly,

$$(W_B)_{rev} = Q \left(1 - \frac{300}{1000} \right) = 0.7Q, \text{ and } (W_B)_{act} = 0.3Q$$

At first glance, both engines seem to convert the same fraction of heat, that they receive, to work, thus performing equally well from the viewpoint of the first law. However, in the light of second law, the engine *B* has a greater work potential ($0.7Q$) available to it and thus should do a lot better than engine *A*. Therefore, it can be said that engine *B* is performing poorly relative to engine *A*, even though both have the same thermal efficiency.

To overcome the deficiency of the first law efficiency, a second law efficiency η_{II} can be defined as the ratio of actual thermal efficiency to the maximum possible thermal efficiency under the same conditions:

$$\eta_{II} = \frac{\eta_I}{\eta_{rev}}$$

So, for engine *A*, $\eta_{II} = 0.3/0.5 = 0.60$

and for engine *B*, $\eta_{II} = 0.3/0.7 = 0.43$

Therefore, the engine *A* is converting 60% of the available work potential (exergy) to useful work. This is only 43% for the engine *B*. Therefore,

$$\eta_{II} = \frac{\eta_{act}}{\eta_{rev}} = \frac{W_u}{W_{rev}} \text{ (for heat engines and other work producing devices)}$$

$$\eta_{II} = \frac{COP}{COP_{rev}} = \frac{W_{rev}}{W_u} \text{ (for refrigerators, heat pumps and other work absorbing devices)}$$

The exergies of a closed system (ϕ) and a flowing fluid stream (ψ) are given on unit mass basis:

$$\phi = (u - u_0) - T_0(s - s_0) + p_0(v - v_0) \text{ kJ/kg}$$

$$\psi = (h - h_0) - T_0(s - s_0) + \frac{V^2}{2} + gz \text{ kJ/kg}$$

Reversible Work Expressions

(a) Cyclic Devices

$$W_{\text{rev}} = \eta_{\text{rev}} Q_1 \text{ (Heat engines)}$$

$$-W_{\text{rev}} = \frac{Q_2}{(COP_{\text{rev}})_{\text{Ref}}} \text{ (Refrigerators)}$$

$$-W_{\text{rev}} = \frac{Q_2}{(COP_{\text{rev}})_{\text{HP}}} \text{ (Heat pumps)}$$

(b) Closed System

$$\begin{aligned} W_{\text{rev}} &= U_1 - U_2 - T_0(S_1 - S_2) + p_0(V_1 - V_2) \\ &= m(\phi_1 - \phi_2) \end{aligned}$$

(c) Steady Flow System (single stream)

$$\begin{aligned} W_{\text{rev}} &= m \left[\left(h_1 + \frac{V_1^2}{2} + gz_1 - T_0 s_1 \right) - \left(h_2 + \frac{V_2^2}{2} + gz_2 - T_0 s_2 \right) \right] \\ &= m(\psi_1 - \psi_2) \end{aligned}$$

When the system exchanges heat with another reservoir at temperature T_k other than the atmosphere,

$$\dot{W}_{\text{rev}} = \dot{m}(\psi_1 - \psi_2) + \dot{Q}_k \left(1 - \frac{T_0}{T_k} \right)$$

The first law efficiency is defined as the ratio of energy output and energy input, while their difference is the energy loss. Likewise, the second law efficiency is defined as the ratio of exergy output and exergy input and their difference is irreversibility. By reducing energy loss, first law efficiency can be improved. Similarly, by reducing irreversibilities, the second law efficiency can be enhanced.

SOLVED EXAMPLES

Example 8.1 In a certain process, a vapour, while condensing at 420°C , transfers heat to water evaporating at 250°C . The resulting steam is used in a power cycle which rejects heat at 35°C . What is the fraction of the available energy in

the heat transferred from the process vapour at 420°C that is lost due to the irreversible heat transfer at 250°C?

Solution *ABCD* (Fig. Ex. 8.1) would have been the power cycle, if there was no temperature difference between the vapour condensing and the water evaporating and the area under *CD* would have been the unavailable energy. *EFGD* is the power cycle when the vapour condenses at 420°C and the water evaporates at 250°C. The unavailable energy becomes the area under *DG*. Therefore, the increase in unavailable energy due to irreversible heat transfer is represented by the area under *CG*.

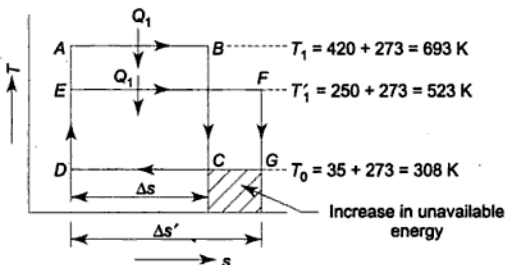

Fig. Ex. 8.1

Now

$$Q_1 = T_1 \Delta S = T_1' \Delta S'$$

$$\frac{\Delta S'}{\Delta S} = \frac{T_1}{T_1'}$$

$$W' = \text{work done in cycle } ABCD$$

$$= (T_1 - T_0) \Delta S$$

$$W'' = \text{Work done in cycle } EFGD$$

$$= (T_1 - T_0) \Delta S'$$

The fraction of energy that becomes unavailable due to irreversible heat transfer

$$= \frac{W - W'}{W} = \frac{T_0 (\Delta S' - \Delta S)}{(T_1 - T_0) \Delta S} = \frac{T_0 \left(\frac{\Delta S'}{\Delta S} - 1 \right)}{(T_1 - T_0)}$$

$$= \frac{T_0 (T_1 - T_1')}{T_1' (T_1 - T_0)} = \frac{308 (693 - 523)}{523 (693 - 308)}$$

$$= 0.26$$

Ans.

Example 8.2 In a steam boiler, hot gases from a fire transfer heat to water which vaporizes at constant temperature. In a certain case, the gases are cooled from 1100°C to 550°C while the water evaporates at 220°C. The specific heat of

gases is 1.005 kJ/kgK , and the latent heat of water at 220°C , is 1858.5 kJ/kg . All the heat transferred from the gases goes to the water. How much does the total entropy of the combined system of gas and water increase as a result of the irreversible heat transfer? Obtain the result on the basis of 1 kg of water evaporated.

If the temperature of the surroundings is 30°C , find the increase in unavailable energy due to irreversible heat transfer.

Solution Gas (\dot{m}_g) is cooled from state 1 to state 2 (Fig. Ex. 8.2). For reversible heat transfer, the working fluid (w.f.) in the heat engine having the same c_p would have been heated along 2-1, so that at any instant, the temperature difference between gas and the working fluid is zero. Then 1-b would have been the expansion of the working fluid down to the lowest possible temperature T_0 , and the amount of heat rejection would have been given by the area *abcd*.

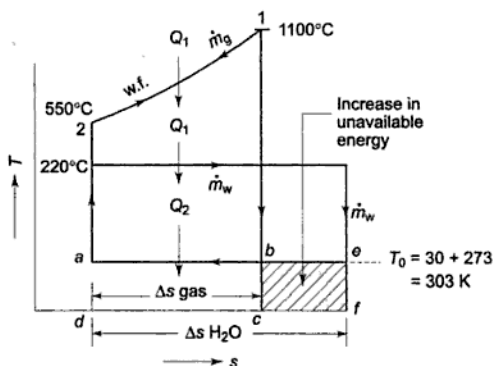

Fig. Ex. 8.2

When water evaporates at 220°C as the gas gets cooled from 1100°C to 550°C , the resulting power cycle has an unavailable energy represented by the area *aefd*. The increase in unavailable energy due to irreversible heat transfer is thus given by area *befc*.

Entropy increase of 1 kg water

$$(\Delta S)_{\text{water}} = \frac{\text{Latent heat absorbed}}{T} = \frac{1858.5}{(273 + 220)} = 3.77 \text{ kJ/kg-K}$$

Q_1 = Heat transferred from the gas

= Heat absorbed by water during evaporation

$$= m_g c_{p_g} (1100 - 550)$$

$$= 1 \times 1858.5 \text{ kJ}$$

$$\therefore \dot{m}_g c_{p_g} = \frac{1858.5}{550} = 3.38 \text{ kJ/}^\circ\text{C}$$

$$\begin{aligned}\Delta S_{\text{gas}} &= \int_{T_{g1}}^{T_{g2}} \frac{dQ}{T} = \int_{T_{g1}}^{T_{g2}} \dot{m}_g c_{p_g} \frac{dT}{T} \\ &= \dot{m}_g c_{p_g} \ln \frac{T_{g2}}{T_{g1}} = 3.38 \ln \frac{823}{1373} \\ &= -3.38 \times 0.51 \\ &= -1.725 \text{ kJ/K}\end{aligned}$$

$$\begin{aligned}\therefore \Delta S_{\text{total}} &= (\Delta S)_{\text{water}} + (\Delta S)_{\text{gas}} \\ &= 3.77 - 1.725 = 2.045 \text{ kJ/K}\end{aligned}$$

Ans.

Increase in unavailale energy

$$\begin{aligned}&= T_0(\Delta S)_{\text{total}} = 303 \times 2.045 \\ &= 620 \text{ kJ}\end{aligned}$$

Ans.

Example 8.3 Calculate the available energy in 40 kg of water at 75°C with respect to the surroundings at 5°C, the pressure of water being 1 atm.

Solution If the water is cooled at a constant pressure of 1 atm from 75°C to 5°C (Fig. Ex. 8.3) the heat given up may be used as a source for a series of Carnot engines each using the surroundings as a sink. It is assumed that the amount of energy received by any engine is small relative to that in the source and the temperature of the source does not change while heat is being exchanged with the engine.

Let us consider that the source has fallen to temperature T , at which level there operates a Carnot engine which takes in heat at this temperature and rejects heat at $T_0 = 278 \text{ K}$. If δs is the entropy change of water, the work obtainable is

$$\delta W = -m(T - T_0)\delta s$$

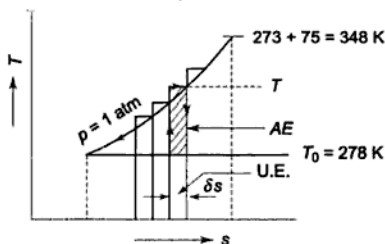

Fig. Ex. 8.3

where δs is negative.

$$\begin{aligned}\delta W &= -40(T - T_0) \frac{c_p \delta T}{T} \\ \therefore &= -40c_p \left(1 - \frac{T_0}{T}\right) \delta T\end{aligned}$$

With a very great number of engines in the series, the total work (maximum) obtainable when the water is cooled from 348 K to 278 K would be

$$\begin{aligned}
 W_{(\max)} &= \text{A.E.} = - \lim_{\Delta T \rightarrow 0} \sum_{348}^{278} 40 c_p \left(1 - \frac{T_0}{T} \right) \delta T \\
 &= \int_{278}^{348} 40 c_p \left(1 - \frac{T_0}{T} \right) dT \\
 &= 40 c_p \left[(348 - 278) - 278 \ln \frac{348}{278} \right] \\
 &= 40 \times 4.2 (70 - 62) \\
 &= 1340 \text{ kJ} \\
 Q_1 &= 40 \times 4.2 (348 - 278) \\
 &= 11,760 \text{ kJ} \\
 \text{U.E.} &= Q_1 - W_{(\max)} \\
 &= 11,760 - 1340 = 10,420 \text{ kJ}
 \end{aligned}$$

Ans.

Example 8.4 Calculate the decrease in available energy when 25 kg of water at 95°C mix with 35 kg of water at 35°C, the pressure being taken as constant and the temperature of the surroundings being 15°C (c_p of water = 4.2 kJ/kg K).

Solution The available energy of a system of mass m , specific heat c_p , and at temperature T , is given by

$$\text{A.E.} = m c_p \int_{T_0}^T \left(1 - \frac{T_0}{T} \right) dT$$

\therefore (A.E.)₂₅ = Available energy of 25 kg of water at 95°C

$$\begin{aligned}
 &= 25 \times 4.2 \int_{273+15}^{273+95} \left(1 - \frac{288}{T} \right) dT \\
 &= 105 \left[(368 - 288) - 288 \ln \frac{368}{288} \right] \\
 &= 987.49 \text{ kJ}
 \end{aligned}$$

(A.E.)₃₅ = Available energy of 35 kg of water at 35°C

$$\begin{aligned}
 &= 147 \left[(308 - 288) - 288 \ln \frac{308}{288} \right] \\
 &= 97.59 \text{ kJ}
 \end{aligned}$$

Total available energy

$$\begin{aligned}
 (\text{A.E.})_{\text{total}} &= (\text{A.E.})_{25} + (\text{A.E.})_{35} \\
 &= 987.49 + 97.59 \\
 &= 1085.08 \text{ kJ}
 \end{aligned}$$

After mixing, if t is the final temperature

$$25 \times 4.2 (95 - t) = 35 \times 4.2(t - 35)$$

$$\therefore t = \frac{25 \times 95 \times 35 \times 35}{25 + 35}$$

$$= 60^\circ\text{C}$$

Total mass after mixing = $25 + 35 = 60$ kg

(A.E.)₆₀ = Available energy of 60 kg of water at 60°C

$$= 4.2 \times 60 \left[(333 - 288) - 288 \ln \frac{333}{288} \right]$$

$$= 803.27 \text{ kJ}$$

\therefore Decrease in available energy due to mixing

$$= \text{Total available energy before mixing}$$

$$- \text{Total available energy after mixing}$$

$$= 1085.08 - 803.27$$

$$= 281.81 \text{ kJ}$$

Ans.

Example 8.5 The moment of inertia of a flywheel is $0.54 \text{ kg}\cdot\text{m}^2$ and it rotates at a speed 3000 RPM in a large heat insulated system, the temperature of which is 15°C . If the kinetic energy of the flywheel is dissipated as frictional heat at the shaft bearings which have a water equivalent of 2 kg, find the rise in the temperature of the bearings when the flywheel has come to rest. Calculate the greatest possible amount of this heat which may be returned to the flywheel as high-grade energy, showing how much of the original kinetic energy is now unavailable. What would be the final RPM of the flywheel, if it is set in motion with this available energy?

Solution Initial angular velocity of the flywheel

$$\omega_1 = \frac{2\pi N_1}{60} = \frac{2\pi \times 3000}{60} = 314.2 \text{ rad/s}$$

Initial available energy of the flywheel

$$= (\text{K.E.})_{\text{initial}} = \frac{1}{2} I \omega_1^2$$

$$= 0.54 \text{ kg m}^2 \times (314.2)^2 \frac{\text{rad}^2}{\text{s}^2}$$

$$= 2.66 \times 10^4 \text{ Nm} = 26.6 \text{ kJ}$$

When this K.E. is dissipated as frictional heat, if Δt is the temperature rise of the bearings, we have

$$\text{water equivalent of the bearings} \times \text{rise in temperature} = 26.6 \text{ kJ}$$

$$\therefore \Delta t = \frac{26.6}{2 \times 4.187} = 3.19^\circ\text{C}$$

Ans.

∴ Final temperature of the bearings

$$t_f = 15 + 3.19 = 18.19^\circ\text{C}$$

The maximum amount of energy which may be returned to the flywheel as high-grade energy is

$$\begin{aligned} \text{A.E.} &= 2 \times 4.187 \int_{288}^{291.19} \left(1 - \frac{288}{T}\right) dT \\ &= 2 \times 4.187 \left[(291.19 - 288) - 288 \ln \frac{291.19}{288} \right] \\ &= 0.1459 \text{ kJ} \end{aligned}$$

The amount of energy rendered unavailable is

$$\begin{aligned} \text{U.E.} &= (\text{A.E.})_{\text{initial}} - (\text{A.E.})_{\text{returnable as high energy}} \\ &= 26.6 - 0.1459 \\ &= 26.4541 \text{ kJ} \end{aligned}$$

Since the amount of energy returnable to the flywheel is 0.146 kJ, if ω_2 is the final angular velocity, and the flywheel is set in motion with this energy

$$0.146 \times 10^3 = \frac{1}{2} \times 0.54 \omega_2^2$$

$$\therefore \omega_2^2 = \frac{146}{0.27} = 540.8$$

$$\therefore \omega_2 = 23.246 \text{ rad/s}$$

If N_2 is the final RPM of the flywheel

$$\omega_2 = 23.246 = \frac{2\pi N_2}{60}$$

$$\text{or } N_2 = \frac{23.246 \times 60}{2 \times \pi} = 222 \text{ RPM} \quad \text{Ans.}$$

Example 8.6 Two kg of air at 500 kPa, 80°C expands adiabatically in a closed system until its volume is doubled and its temperature becomes equal to that of the surroundings which is at 100 kPa, 5°C . For this process, determine (a) the maximum work, (b) the change in availability, and (c) the irreversibility. For air, take $c_v = 0.718 \text{ kJ/kg K}$, $u = c_v T$ where c_v is constant, and $pV = mRT$ where p is pressure in kPa, V volume in m^3 , m mass in kg, R a constant equal to 0.287 kJ/kg K , and T temperature in K.

Solution From the property relation

$$TdS = dU + pdV$$

the entropy change of air between the initial and final states is

$$\int_1^2 dS = \int_1^2 \frac{m c_v dT}{T} + \int_1^2 \frac{m R dV}{V}$$

$$\text{or } S_2 - S_1 = mc_v \ln \frac{T_2}{T_1} + mR \ln \frac{V_2}{V_1}$$

From Eq. (8.32),

$$\begin{aligned} W_{\max} &= (U_1 - U_2) - T_0 (S_1 - S_2) \\ &= m \left[c_v (T_1 - T_2) + T_0 \left(c_v \ln \frac{T_2}{T_1} + R \ln \frac{V_2}{V_1} \right) \right] \\ &= 2 \left[0.718(80 - 5) + 278 \left(0.718 \ln \frac{278}{353} + 0.287 \ln \frac{2}{1} \right) \right] \\ &= 2 [53.85 + 278 (-0.172 + 0.199)] \\ &= 2 (53.85 + 7.51) \\ &= 122.72 \text{ kJ} \end{aligned} \quad \text{Ans. (a)}$$

From Eq. (8.42), the change in availability

$$\begin{aligned} &= \phi_1 - \phi_2 \\ &= (U_1 - U_2) - T_0(S_1 - S_2) + p_0(V_1 - V_2) \\ &= W_{\max} + p_0(V_1 - V_2) \\ &= 122.72 + p_0(V_1 - 2V_1) \\ &= 122.72 - 100 \times \frac{2 \times 0.287 \times 353}{500} \\ &= 82.2 \text{ kJ} \end{aligned} \quad \text{Ans. (b)}$$

The irreversibility

$$I = W_{\max, \text{useful}} - W_{\text{act}}$$

From the first law,

$$\begin{aligned} W_{\text{act}} &= Q - \Delta U = -\Delta U = U_1 - U_2 \\ \therefore I &= U_1 - U_2 - T_0(S_1 - S_2) - U_1 + U_2 \\ &= T_0(S_2 - S_1) \\ &= T_0(\Delta S)_{\text{system}} \end{aligned}$$

For adiabatic process, $(\Delta S)_{\text{surr}} = 0$

$$\begin{aligned} I &= T_0 \left[mc_v \ln \frac{T_2}{T_1} + mR \ln \frac{V_2}{V_1} \right] \\ &= 278 \times 2 \left[0.718 \ln \frac{278}{353} + 0.287 \ln 2 \right] \\ &= 278 \times 2 (-0.172 + 0.199) \\ &= 15.2 \text{ kJ} \end{aligned} \quad \text{Ans. (c)}$$

Example 8.7 Air expands through a turbine from 500 kPa, 520°C to 100 kPa, 300°C. During expansion 10 kJ/kg of heat is lost to the surroundings which is at 98 kPa, 20°C. Neglecting the K.E. and P.E. changes, determine per kg of air (a) the decrease in availability, (b) the maximum work, and (c) the irreversibility.

For air, take $c_p = 1.005 \text{ kJ/kg K}$, $h = c_p T$ where c_p is constant, and the p , V and T relation as in Example 8.6.

Solution From the property relation

$$Tds = dH - V dp$$

the entropy change of air in the expansion process is

$$\int_1^2 ds = \int_1^2 \frac{m c_p dT}{T} - \int_1^2 \frac{m R dp}{p}$$

or
$$S_2 - S_1 = m c_p \ln \frac{T_2}{T_1} - m R \ln \frac{p_2}{p_1}$$

For 1 kg of air,

$$s_2 - s_1 = c_p \ln \frac{T_2}{T_1} - R \ln \frac{p_2}{p_1}$$

From Eq. (8.30), the change in availability

$$\begin{aligned} \psi_1 - \psi_2 &= b_1 - b_2 \\ &= (h_1 - T_0 s_1) - (h_2 - T_0 s_2) \\ &= (h_1 - h_2) - T_0 (s_1 - s_2) \\ &= c_p (T_1 - T_2) - T_0 \left(R \ln \frac{p_2}{p_1} - c_p \ln \frac{T_2}{T_1} \right) \\ &= 1.005 (520 - 300) - 293 \left(0.287 \ln \frac{1}{5} - 1.005 \ln \frac{573}{793} \right) \\ &= 1.005 \times 220 - 293 (0.3267 - 0.4619) \\ &= 221.1 + 39.6 \\ &= 260.7 \text{ kJ/kg} \end{aligned} \quad \text{Ans. (a)}$$

The maximum work is

$$\begin{aligned} W_{\max} &= \text{change in availability} = \psi_1 - \psi_2 \\ &= 260.7 \text{ kJ/kg} \end{aligned} \quad \text{Ans. (b)}$$

From S.F.E.E.,

$$\begin{aligned} Q + h_1 &= W + h_2 \\ W &= (h_1 - h_2) + Q \\ &= c_p (T_1 - T_2) + Q \\ &= 1.005 (520 - 300) - 10 \\ &= 211.1 \text{ kJ/kg} \end{aligned}$$

The irreversibility

$$\begin{aligned} I &= W_{\max} - W \\ &= 260.7 - 211.1 \\ &= 49.6 \text{ kJ/kg} \end{aligned} \quad \text{Ans. (c)}$$

Alternatively,

$$\begin{aligned}
 I &= T_0(\Delta S_{\text{system}} + \Delta S_{\text{surr}}) \\
 &= 293 \left[1.005 \ln \frac{573}{793} - 0.287 \ln \frac{1}{5} + \frac{10}{293} \right] \\
 &= 293 \times 0.1352 + 10 \\
 &= 49.6 \text{ kJ/kg} \qquad \text{Ans. (d)}
 \end{aligned}$$

Example 8.8 An air preheater is used to cool the products of combustion from a furnace while heating the air to be used for combustion. The rate of flow of products is 12.5 kg/s and the products are cooled from 300 to 200°C, and for the products at this temperature $c_p = 1.09 \text{ kJ/kg K}$. The rate of air flow is 11.5 kg/s, the initial air temperature is 40°C, and for the air $c_p = 1.005 \text{ kJ/kg K}$. (a) Estimate the initial and final availability of the products. (b) What is the irreversibility for the process? (c) If the heat transfer from the products occurs reversibly through heat engines, what is the final temperature of the air? What is the power developed by the heat engine? Take $T_0 = 300 \text{ K}$ and neglect pressure drop for both the fluids and heat transfer to the surroundings.

Solution

(a) $\psi_1 =$ initial availability of the products

$$\begin{aligned}
 &= (h_1 - h_0) - T_0(S_1 - S_0) \\
 &= c_{p_g}(T_{g_1} - T_0) - T_0 c_{p_g} \ln \frac{T_{g_1}}{T_0} \\
 &= 1.09(573 - 300) - 300 \times 1.09 \ln \frac{573}{300} \\
 &= 297.57 - 211.6 = 39.68 \text{ kJ/kg} \\
 \psi_2 &= \text{final availability of the products} \\
 &= (h_2 - h_0) - T_0(s_2 - s_0) \\
 &= 1.09(473 - 300) - 300 \times 1.09 \ln \frac{473}{300} \\
 &= 188.57 - 148.89 = 39.68 \text{ kJ/kg}
 \end{aligned}$$

(b) Decrease in availability of the products

$$\begin{aligned}
 &= \psi_1 - \psi_2 \\
 &= (h_1 - h_2) - T_0(s_1 - s_2) \\
 &= 1.09(573 - 473) - 300 \times 1.09 \ln \frac{573}{473} \\
 &= 109 - 62.72 = 46.28 \text{ kJ/kg}
 \end{aligned}$$

By making an energy balance for the air preheater [Fig. Ex. 8.8(a)].

$$\begin{aligned}
 \dot{m}_g c_{p_g}(T_{g_1} - T_{g_2}) &= \dot{m}_a c_{p_a}(T_{a_2} - T_{a_1}) \\
 12.5 \times 1.09(573 - 473) &= 11.5 \times 1.005(T_{a_2} - 313)
 \end{aligned}$$

$$\therefore T_{a_2} = \frac{12.5 \times 109}{11.5 \times 1.005} + 313 = 430.89 \text{ K}$$

Increase in availability for air

$$= \psi_2 - \psi_1$$

$$= (h_2 - h_1) - T_0(s_2 - s_1)$$

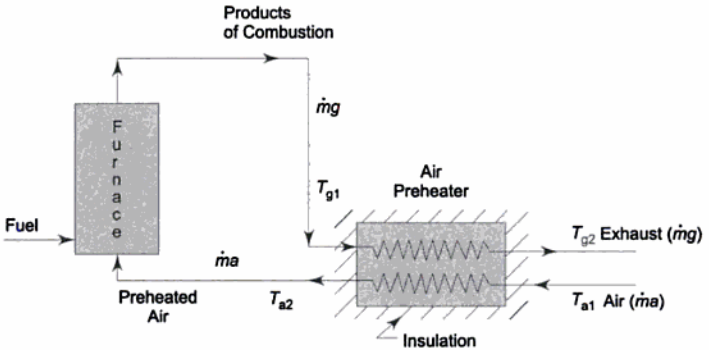

Fig. Ex. 8.8(a)

$$= c_{p_a} (T_{a_2} - T_{a_1}) - T_0 c_{p_a} \ln \frac{T_{a_2}}{T_{a_1}}$$

$$= 1.005 \times (430.89 - 313) - 300 \times 1.005 \ln \frac{430.89}{313}$$

$$= 118.48 - 96.37 = 22.11 \text{ kJ/kg}$$

∴ Irreversibility of the process

$$= 12.5 \times 46.28 - 11.5 \times 22.11$$

$$= 578.50 - 254.27$$

$$= 324.23 \text{ kW}$$

(c) Let us assume that heat transfer from the products to air occurred through heat engines reversibly as shown in Fig. Ex. 8.8(b).

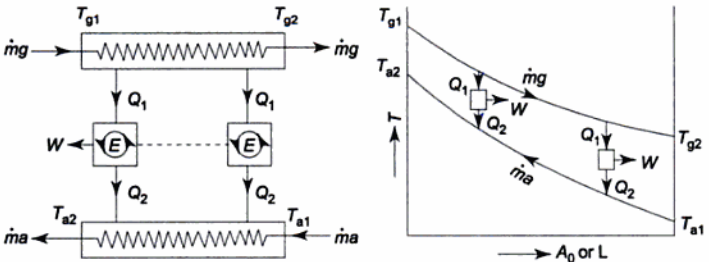

Fig. Ex. 8.8(b)

For reversible heat transfer,

$$\Delta \dot{S}_{\text{univ}} = 0$$

$$\Delta \dot{S}_{\text{sys}} + \Delta \dot{S}_{\text{surr}} = 0$$

$$\Delta \dot{S}_{\text{gas}} + \Delta \dot{S}_{\text{air}} = 0$$

$$\Delta \dot{S}_{\text{gas}} = -\Delta \dot{S}_{\text{air}}$$

$$\dot{m}_g c_{p_g} \ln \frac{T_{g2}}{T_{g1}} = -\dot{m}_a c_{p_a} \ln \frac{T_{a2}}{T_{a1}}$$

$$12.5 \times 1.09 \ln \frac{473}{573} = -11.5 \times 1.005 \ln \frac{T_{a2}}{313}$$

$$\therefore T_{a2} = 392.41 \text{ K}$$

Rate of heat supply from the gas to the working fluid in the heat engine,

$$\begin{aligned} \dot{Q}_1 &= \dot{m}_g c_{p_g} (T_{g1} - T_{g2}) \\ &= 12.5 \times 1.09 (573 - 473) \\ &= 1362.50 \text{ kW} \end{aligned}$$

Rate of heat rejection from the working fluid in the heat engine to the air,

$$\begin{aligned} \dot{Q}_2 &= \dot{m}_a c_{p_a} (T_{a2} - T_{a1}) \\ &= 11.5 \times 1.005 (392.41 - 313) \\ &= 917.78 \text{ kW} \end{aligned}$$

Total power developed by the heat engine

$$\begin{aligned} \dot{W} &= \dot{Q}_1 - \dot{Q}_2 = 1362.50 - 917.78 \\ &= 444.72 \text{ kW} \end{aligned}$$

Example 8.9 A gas is flowing through a pipe at the rate of 2 kg/s. Because of inadequate insulation the gas temperature decreases from 800 to 790°C between two sections in the pipe. Neglecting pressure losses, calculate the irreversibility rate (or rate of energy degradation) due to this heat loss. Take $T_0 = 300 \text{ K}$ and a constant $c_p = 1.1 \text{ kJ/kg K}$.

For the same temperature drop of 10°C when the gas cools from 80°C to 70°C due to heat loss, what is the rate of energy degradation? Take the same values of T_0 and c_p . What is the inference you can draw from this example?

$$\begin{aligned} \text{Solution} \quad \dot{S}_{\text{gen}} &= \dot{S}_{\text{sys}} - \frac{\dot{Q}}{T_0} \\ &= \dot{m}(s_2 - s_1) - \frac{\dot{m} c_p (T_2 - T_1)}{T_0} \end{aligned}$$

Irreversibility rate = rate of energy degradation
= rate of exergy loss

$$\begin{aligned}
 \dot{i} &= T_0 \dot{S}_{\text{gen}} \\
 &= \dot{m} T_0 (s_2 - s_1) - \dot{m} c_p (T_2 - T_1) \\
 &= \dot{m} c_p \left[(T_1 - T_2) - T_0 \ln \frac{T_1}{T_2} \right] \\
 &= 2 \times 1.1 \left[(1073 - 1063) - 300 \ln \frac{1073}{1063} \right] \\
 &= 15.818 \text{ kW}
 \end{aligned}$$

When the same heat loss occurs at lower temperature

$$\begin{aligned}
 \dot{i} &= 2 \times 1.1 \left[(353 - 343) - 300 \ln \frac{353}{343} \right] \\
 &= 3.036 \text{ kW}
 \end{aligned}$$

It is thus seen that irreversibility rate of exergy destruction is more when the same heat loss occurs at higher temperature. Irreversibility rate decreases as the temperature of the gas decreases. Quantitatively, the heat loss may be the same, but qualitatively, it is different.

Example 8.10 An ideal gas is flowing through an insulated pipe at the rate of 3 kg/s. There is a 10% pressure drop from inlet to exit of the pipe. What is the rate of exergy loss because of the pressure drop due to friction? Take $R = 0.287 \text{ kJ/kg K}$ and $T_0 = 300 \text{ K}$.

Solution Rate of entropy generation from Eq. (8.68),

$$\begin{aligned}
 \dot{S}_{\text{gen}} &= \dot{m} R \frac{\Delta p}{p_1} \\
 &= 3 \times 0.287 \frac{0.10 p_1}{p_1} \\
 &= 0.0861 \text{ kW/K}
 \end{aligned}$$

Rate of exergy loss

$$\begin{aligned}
 \dot{i} &= T_0 \dot{S}_{\text{gen}} \\
 &= 300 \times 0.0861 \\
 &= 25.83 \text{ kW}
 \end{aligned}$$

Example 8.11 Water at 90°C flowing at the rate of 2 kg/s mixes adiabatically with another stream of water at 30°C flowing at the rate of 1 kg/s. Estimate the entropy generation rate and the rate of exergy loss due to mixing. Take $T_0 = 300 \text{ K}$.

Solution

$$\dot{m} = \dot{m}_1 + \dot{m}_2 = 2 + 1 = 3 \text{ kg/s}$$

Here
$$x = \frac{\dot{m}_1}{\dot{m}} = \frac{2}{3} = 0.67$$

$$\tau = \frac{T_2}{T_1} = \frac{303}{363} = 0.835$$

From Eq. (8.76),

$$\begin{aligned}\dot{S}_{\text{gen}} &= \dot{m} c_p \ln \frac{x + \tau(1-x)}{\tau^{1-x}} \\ &= 3 \times 4.187 \ln \frac{0.67 + 0.835 \times 0.33}{0.835^{0.33}} \\ &= 12.561 \ln \frac{0.94555}{0.94223} \\ &= 0.0442 \text{ kW/K}\end{aligned}$$

Rate of exergy loss due to mixing

$$\begin{aligned}\dot{I} &= T_0 \dot{S}_{\text{gen}} \\ &= 300 \times 0.0442 \\ &= 13.26 \text{ kW}\end{aligned}$$

Alternatively,

Equilibrium temperature after mixing,

$$\begin{aligned}t &= \frac{m_1 t_1 + m_2 t_2}{m_1 + m_2} \\ &= \frac{2 \times 90 + 1 \times 30}{2 + 1} = 70^\circ\text{C}\end{aligned}$$

$$\begin{aligned}\Delta \dot{S}_{\text{univ}} &= \dot{S}_{\text{gen}} = 2 \times 4.187 \ln \frac{343}{363} + 1 \times 4.187 \ln \frac{343}{303} \\ &= 0.0447 \text{ kW/K}\end{aligned}$$

$$\therefore \dot{I} = 300 \times 0.0447 = 13.41 \text{ kW}$$

Example 8.12 By burning a fuel the rate of heat release is 500 kW at 2000 K. What would be the first law and the second law efficiencies if (a) energy is absorbed in a metallurgical furnace at the rate of 480 kW at 1000 K, (b) energy is absorbed at the rate of 450 kW for generation of steam at 500 K, and (c) energy is absorbed in a chemical process at the rate of 300 kW at 320 K? Take $T_0 = 300$ K, (d) Had the energy absorption rate been equal to 450 kW in all these three cases, what would have been the second law efficiencies? What is the inference that you can draw from this example?

Solution If \dot{Q}_r is the rate of heat release at temperature T_r , and \dot{Q}_a the rate of heat absorption at temperature T_a , then

$$\eta_I = \frac{\dot{Q}_a}{\dot{Q}_r} \quad \text{and} \quad \eta_{II} = \eta_I \frac{1 - \frac{T_0}{T_a}}{1 - \frac{T_0}{T_r}}$$

(a) Metallurgical furnace

$$\eta_I = \frac{480}{500} \times 100 = 96\%$$

$$\eta_{II} = 0.96 \frac{1 - \frac{300}{1000}}{1 - \frac{300}{2000}} \times 100 = 79\%$$

(b) Steam generation

$$\eta_I = \frac{450}{500} \times 100 = 90\%$$

$$\eta_{II} = 0.90 \frac{1 - \frac{300}{500}}{1 - \frac{300}{2000}} \times 100 = 42.3\%$$

(c) Chemical process

$$\eta_I = \frac{300}{500} \times 100 = 60\%$$

$$\eta_{II} = 0.60 \frac{1 - \frac{300}{320}}{1 - \frac{300}{2000}} \times 100 = 4.41\%$$

(d) In all the three cases, η_I would remain the same, where

$$\eta_I = \frac{450}{500} \times 100 = 90\%$$

$$\eta_{II(a)} = 0.90 \times \frac{1 - \frac{300}{1000}}{1 - \frac{300}{2000}} \times 100 = 74.11\%$$

$$\eta_{II(b)} = 0.90 \times \frac{1 - \frac{300}{500}}{1 - \frac{300}{2000}} \times 100 = 42.3\%$$

$$\eta_{II(c)} = 0.90 \times \frac{1 - \frac{300}{320}}{1 - \frac{300}{2000}} \times 100 = 6.61\%$$

It is seen that as the energy loss ($\dot{Q}_r - \dot{Q}_a$) increases, the first law efficiency decreases. For the same heat loss, however, as the temperature difference between the source and the use temperature increases, the second law efficiency decreases, or in other words, the rate of exergy loss increases.

Example 8.13 A system undergoes a power cycle while receiving energy Q_1 at temperature T_1 and discharging energy Q_2 at temperature T_2 . There are no other heat transfers.

(a) Show that the thermal efficiency of the cycle can be expressed as:

$$\eta = 1 - \frac{T_2}{T_1} - \frac{T_2 I}{T_0 Q_1}$$

where T_0 is the ambient temperature and I is the irreversibility of the cycle.

(b) Obtain an expression for the maximum theoretical value for the thermal efficiency.

(c) Derive an expression for the irreversibility for which no network is developed by the cycle. What conclusion do you derive from it?

Solution An availability balance for the cycle gives (Fig. Ex. 8.13),

$$(\Delta A)_{\text{cycle}} = 0 = \left(1 - \frac{T_0}{T_1}\right) Q_1 - \left(1 - \frac{T_0}{T_2}\right) Q_2 - W - I$$

since each property is restored to its initial state.

Since

$$Q_2 = Q_1 - W,$$

$$0 = \left(1 - \frac{T_0}{T_1}\right) Q_1 - \left(1 - \frac{T_0}{T_2}\right) (Q_1 - W) - W - I$$

$$W = \frac{T_2}{T_0} \left[\left(1 - \frac{T_0}{T_1}\right) - \left(1 - \frac{T_0}{T_2}\right) \right] Q_1 - \frac{T_2 I}{T_0}$$

$$\eta = \frac{W}{Q_1} = 1 - \frac{T_2}{T_1} - \frac{T_2 I}{T_0 Q_1}$$

Proved.

(b) When $I = 0$,

$$\eta_{\text{max}} = 1 - \frac{T_2}{T_1}$$

(c) When $W = 0$

$$\eta = 0 = 1 - \frac{T_2}{T_1} - \frac{T_2 I}{T_0 Q_1}$$

$$I = T_0 \left[\frac{1}{T_2} - \frac{1}{T_1} \right] Q_1 = T_0 \left[\frac{Q_1}{T_2} - \frac{Q_1}{T_1} \right] = T_0 S_{\text{gen}}$$

The heat transfer Q_1 from T_1 to T_2 takes place through a reversible engine, and the entire work is dissipated in the brake, from which an equal amount of heat is

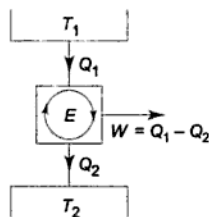

Fig. Ex. 8.13

rejected to the reservoir at T_2 . Heat transfer through a finite temperature difference is thus equivalent to the destruction of its exergy. (See Art. 8.10.1(a)).

Example 8.14 A compressor operating at steady state takes in 1 kg/s of air at 1 bar and 25°C and compresses it to 8 bar and 160°C. Heat transfer from the compressor to its surroundings occurs at a rate of 100 kW. (a) Determine the power input in kW. (b) Evaluate the second law efficiency for the compressor. Neglect KE and PE changes. Take $T_0 = 25^\circ\text{C}$ and $P_0 = 1$ bar.

Solution SFEE for the compressor (Fig. Ex. 8.14) gives:

$$\begin{aligned}\dot{W} &= \dot{Q} + \dot{m}(h_1 - h_2) = -100 + 1 \times 1.005(25 - 160) \\ &= -235.7 \text{ kW} \quad \text{Ans. (a)}\end{aligned}$$

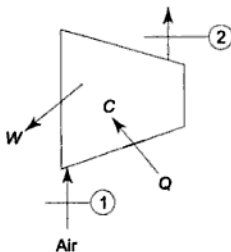

Fig. Ex. 8.14

Exergy balance for the compressor gives:

$$\begin{aligned}\dot{m}a_{f_1} + \dot{Q}\left(1 - \frac{T_0}{T}\right) - \dot{W} - \dot{m}a_{f_2} &= i \\ -\dot{W} &= \dot{m}(a_{f_2} - a_{f_1}) - \dot{Q}\left(1 - \frac{T_0}{T}\right) + i \\ \eta_{II} &= \frac{\dot{m}(a_{f_2} - a_{f_1})}{\dot{W}} \\ a_{f_2} - a_{f_1} &= h_2 - h_1 - T_0(s_2 - s_1) \\ &= c_p(T_2 - T_1) - T_0\left(c_p \ln \frac{T_2}{T_1} - R \ln \frac{P_2}{P_1}\right) \\ &= 1.005(160 - 25) - 298\left(1.005 \ln \frac{433}{298} - 0.287 \ln 8\right) \\ &= 200.95 \text{ kJ/kg} \\ \eta_{II} &= \frac{200.95}{235.7} = 0.853 \text{ or, } 85.3\% \quad \text{Ans. (b)}\end{aligned}$$

Example 8.15 Determine the exergy of 1 m³ of complete vacuum.

Solution

$$\phi = U - U_0 + p_0(V - V_0) - T_0(S - S_0)$$

$$= H - H_0 - V(p - p_0) - T_0(S - S_0)$$

Since a vacuum has zero mass,

$$U = 0, H = 0, \text{ and } S = 0$$

If the vacuum were reduced to the dead state,

$$U_0 = 0, H_0 = 0, S_0 = 0 \text{ and } V_0 = 0.$$

The pressure p for the vacuum is zero.

But $p_0 = 1 \text{ bar} = 100 \text{ kPa}$ and $V = 1 \text{ m}^3$

$$\phi = p_0 V = 100 \frac{\text{kN}}{\text{m}^2} \times 1 \text{ m}^3 = 100 \text{ kJ} \quad \text{Ans.}$$

If an air motor operates between the atmosphere and the vacuum, this is the maximum useful work obtainable. Therefore, the vacuum has an exergy or work potential.

Example 8.16 A mass of 1000 kg of fish initially at 1 bar, 300K is to be cooled to -20°C . The freezing point of fish is -2.2°C , and the specific heats of fish below and above the freezing point are 1.7 and 3.2 kJ/kg K respectively. The latent heat of fusion for the fish can be taken as 235 kJ/kg. Calculate the exergy produced in the chilling process. Take $T_0 = 300 \text{ K}$ and $p_0 = 1 \text{ bar}$.

Solution

$$\text{Exergy produced} = H_2 - H_1 - T_0(S_2 - S_1)$$

With reference to Fig. Ex. 8.16,

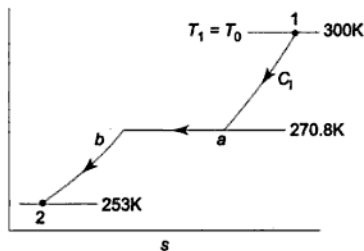

Fig. Ex. 8.16

$$\begin{aligned} H_1 - H_2 &= 1000 [1.7(270.8 - 253) + 235 + 3.2(300 - 270.8)] \\ &= 1000 [1.7 \times 17.8 + 235 + 3.2 \times 29.2] \\ &= 1000 [30.26 + 235 + 93.44] = 358.7 \text{ MJ} \end{aligned}$$

$$H_2 - H_1 = -358.7 \text{ MJ}$$

$$\begin{aligned} S_1 - S_2 &= 1000 \left[1.7 \ln \frac{270.8}{253} + \frac{235}{270.8} + 3.2 \ln \frac{300}{270.8} \right] \\ &= -1000 [0.1156 + 0.8678 + 0.3277] \end{aligned}$$

$$\begin{aligned}
 &= 1.311 \text{ MJ/K} \\
 S_2 - S_1 &= -1.311 \text{ MJ/K} \\
 \text{Exergy produced} &= -358.7 + 300 \times 1.311 \\
 &= -358.7 + 393.3 \\
 &= 34.6 \text{ MJ or } 9.54 \text{ kWh}
 \end{aligned}$$

Ans.

Example 8.17 A quantity of air initially at 1 bar, 300 K undergoes two types of interactions: (a) it is brought to a final temperature of 500 K adiabatically by paddle-wheel work transfer, (b) the same temperature rise is brought about by heat transfer from a thermal reservoir at 600 K. Take $T_0 = 300 \text{ K}$, $p_0 = 1 \text{ atm}$. Determine the irreversibility (in kJ/kg) in each case and comment on the results.

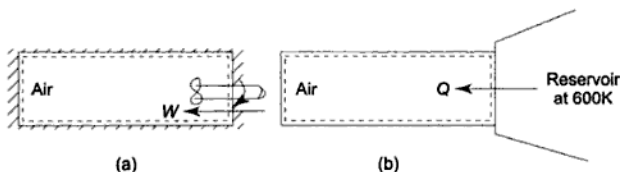

Fig. Ex. 8.17

Solution Case (a): As shown in the above figures (Fig. Ex. 8.17),

$$\begin{aligned}
 \Delta s_{\text{univ}} = s_{\text{gen}} &= c_v \ln \frac{T_2}{T_1} = 0.718 \ln \frac{500}{300} \\
 &= 0.367 \text{ kJ/kg K} \\
 I &= 300 \times 0.367 = 110.1 \text{ kJ/kg}
 \end{aligned}$$

Ans.

Case (b):

$$\begin{aligned}
 Q &= m c_v (T_2 - T_1) \\
 &= 1 \times 0.718 (500 - 300) = 143.6 \text{ kJ/kg} \\
 \Delta s_{\text{univ}} &= s_2 - s_1 - \frac{Q_1}{T} = 0.367 - \frac{143.6}{600} \\
 &= 0.1277 \text{ kJ/kg K} \\
 I &= 300 \times 0.1277 = 38.31 \text{ kJ/kg}
 \end{aligned}$$

Comment:

The irreversibility in case (b) is less than in case (a).

$$\begin{aligned}
 I_a &= T_0(s_2 - s_1), I_b = T_0(s_2 - s_1) - \frac{Q}{T} \\
 I_a - I_b &= \frac{Q}{T}
 \end{aligned}$$

The irreversibility in case (b) is always less than in case (a) and the two values would approach each other only at high reservoir temperature, i.e.,

$$I_a \rightarrow I_b \text{ as } T \rightarrow \infty$$

Example 8.18 Steam enters a turbine at 30 bar, 400°C ($h = 3230$ kJ/kg, $s = 6.9212$ kJ/kg K) and with a velocity of 160 m/s. Steam leaves as saturated vapour at 100°C ($h = 2676.1$ kJ/kg, $s = 7.3549$ kJ/kg K) with a velocity of 100 m/s. At steady state the turbine develops work at a rate of 540 kJ/kg. Heat transfer between the turbine and its surroundings occurs at an average outer surface temperature of 500 K. Determine the irreversibility per unit mass. Give an exergy balance and estimate the second law efficiency of the turbine. Take $p_0 = 1$ atm, $T_0 = 298$ K and neglect PE effect.

Solution By exergy balance of the control volume (Fig. Ex. 8.18),

$$a_{f_1} = W + Q \left(1 - \frac{T_0}{T_B} \right) + a_{f_2} + I$$

where a_f is the exergy transfer per unit mass.

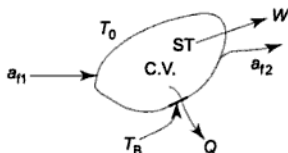

Fig. Ex. 8.18

$$\begin{aligned} I &= a_{f_1} - a_{f_2} - W - Q \left(1 - \frac{T_0}{T_B} \right) \\ &= (h_1 - h_2) - T_0(s_1 - s_2) + \frac{V_1^2 - V_2^2}{2} - W - Q \left(1 - \frac{T_0}{T_B} \right) \\ &= (3230.9 - 2676.1) - 298(6.9212 - 7.3549) + \frac{160^2 - 100^2}{2} \\ &\quad \times 10^{-3} - 540 - Q \left(1 - \frac{298}{500} \right) \\ &= 151.84 - Q(0.404) \end{aligned} \quad (1)$$

By SFEE,

$$\begin{aligned} h_1 + \frac{V_1^2}{2} &= W + h_2 + Q + \frac{V_2^2}{2} \\ Q &= (h_1 - h_2) + \frac{V_1^2 - V_2^2}{2} - W \\ &= (3230.9 - 2676.1) + \frac{160^2 - 100^2}{2} \times 10^{-3} - 540 \\ &= 22.6 \text{ kJ/kg.} \end{aligned}$$

From Eq. (1),

$$I = 151.84 - 22.6 \times 0.404 = 42.71 \text{ kJ/kg} \quad \text{Ans.}$$

Net exergy transferred to turbine

$$a_{f_1} - a_{f_2} = 691.84 \text{ kJ/kg}$$

$$\text{Work} = 540 \text{ kJ/kg}$$

$$\text{Exergy destroyed} = I = 142.71 \text{ kJ/kg}$$

Exergy transferred out accompanying heat transfer

$$= 22.6 \times 0.404 = 9.13 \text{ kJ/kg}$$

Exergy Balance

Exergy transferred

$$691.84 \text{ kJ/kg}$$

Exergy utilized

$$\text{Work} = 540 \text{ kJ/kg (78\%)}$$

$$\text{Destroyed} = 142.71 \text{ kJ/kg (20.6\%)}$$

$$\text{Transferred with heat} = 9.13 \text{ kJ/kg (1.3\%)}$$

$$691.84 \text{ kJ/kg}$$

$$\text{Second law efficiency, } \eta_{II} = \frac{540}{691.84} = 0.78 \text{ or } 78\% \quad \text{Ans.}$$

Example 8.19 A furnace is heated by an electrical resistor. At steady state, electrical power is supplied to the resistor at a rate of 8.5 kW per metre length to maintain it at 1500 K when the furnace walls are at 500 K. Let $T_0 = 300$ K (a) For the resistor as the system, determine the rate of availability transfer accompanying heat and the irreversibility rate, (b) For the space between the resistor and the walls as the system, evaluate the irreversibility rate.

Solution Case (a): At steady state for the resistor (Fig. Ex. 8.19),

$$\dot{Q} = \Delta \dot{U} + \dot{W} = \dot{W} = 8.5 \text{ kW}$$

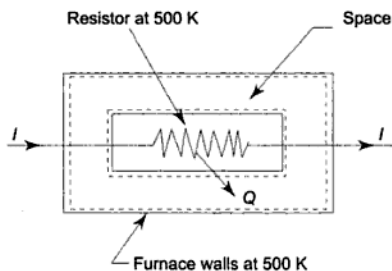

Fig. Ex. 8.19

Availability rate balance gives

$$\frac{dA}{dt} = \left(1 - \frac{T_0}{T}\right) \dot{Q} + \left(\dot{W} - p_0 \frac{dV}{dt}\right) - \dot{i} = 0$$

$$\begin{aligned} \dot{i} &= \text{Rate of irreversibility} \\ &= \left(1 - \frac{T_0}{T}\right) \dot{Q} + \dot{W} = \left(1 - \frac{300}{1500}\right) (-8.5) + 8.5 \\ &= 1.7 \text{ kW} \end{aligned} \quad \text{Ans. (a)}$$

Rate of availability transfer with heat

$$= \left(1 - \frac{T_0}{T}\right) \dot{Q} = \left(1 - \frac{300}{1500}\right) (-8.5) = -6.8 \text{ kW} \quad \text{Ans. (a)}$$

Case (b): Steady state,

$$\begin{aligned} \frac{dA}{dT} &= \left(1 - \frac{T_0}{T}\right) \dot{Q} - \left(1 - \frac{T_0}{T_w}\right) \dot{Q} - \dot{W} - \dot{i} = 0 \\ \dot{i} &= \left(1 - \frac{300}{1500}\right) 8.5 - \left(1 - \frac{300}{500}\right) 8.5 \\ &= 6.8 - 3.4 = 3.4 \text{ kW} \end{aligned} \quad \text{Ans. (b)}$$

Example 8.20 Air enters a compressor at 1 bar, 30°C, which is also the state of the environment. It leaves at 3.5 bar, 141°C and 90 m/s. Neglecting inlet velocity and P.E. effect, determine (a) whether the compression is adiabatic or polytropic, (b) if not adiabatic, the polytropic index, (c) the isothermal efficiency, (d) the minimum work input and irreversibility, and (d) the second law efficiency. Take c_p of air = 1.0035 kJ/kgK.

(a) After isentropic compression

$$\begin{aligned} \frac{T_{2s}}{T_1} &= \left[\frac{p_2}{p_1}\right]^{(\gamma-1)/\gamma} \\ T_{2s} &= 303 (3.5)^{0.286} = 433.6 \text{ K} = 160.6^\circ\text{C} \end{aligned}$$

Since this temperature is higher than the given temperature of 141°C, there is heat loss to the surroundings. The compression cannot be adiabatic. It must be polytropic.

$$\begin{aligned} \text{(b)} \quad \frac{T_2}{T_1} &= \left[\frac{p_2}{p_1}\right]^{(n-1)/n} \\ \frac{141 + 273}{30 + 273} &= 1.366 = \left(\frac{3.5}{1}\right)^{(n-1)/n} \\ \log 1.366 &= \frac{n-1}{n} \log 3.5 \\ 1 - \frac{1}{n} &= \frac{0.135}{0.544} = 0.248 \\ n &= 1.32978 = 1.33 \end{aligned} \quad \text{Ans.}$$

(c) Actual work of compression

$$W_a = h_1 - h_2 - \frac{V_2^2}{2} = 1.0035 (30 - 141) - \frac{90^2}{2} \times 10^{-3}$$

$$= -115.7 \text{ kJ/kg}$$

Isothermal work

$$W_T = \int_1^2 v dp - \frac{V_2^2}{2} = -RT_1 \ln \frac{p_2}{p_1} - \frac{V_2^2}{2}$$

$$= -0.287 \times 303 \ln (3.5) - \frac{90^2}{2} \times 10^{-3}$$

$$= -113 \text{ kJ/kg}$$

Isothermal efficiency:

$$\eta_T = \frac{W_T}{W_a} = \frac{113}{115.7} = 0.977 \text{ or } 97.7\% \quad \text{Ans.}$$

(d) Decrease in availability or exergy:

$$\psi_1 - \psi_2 = h_1 - h_2 - T_0(s_1 - s_2) + \frac{V_1^2 - V_2^2}{2}$$

$$= c_p(T_1 - T_2) - T_0 \left[R \ln \frac{p_2}{p_1} - c_p \ln \frac{T_2}{T_1} \right] - \frac{V_2^2}{2}$$

$$= 1.0035 (30 - 141)$$

$$- 303 \left[0.287 \ln 3.5 - 1.0035 \ln \frac{414}{303} \right] - \frac{90^2}{2000}$$

$$= -101.8 \text{ kJ/kg}$$

$$\text{Minimum work input} = -101.8 \text{ kJ/kg} \quad \text{Ans.}$$

Irreversibility,

$$I = W_{\text{rev}} - W_a$$

$$= -101.8 - (-115.7)$$

$$= 13.9 \text{ kJ/kg} \quad \text{Ans.}$$

(e) Second law efficiency,

$$\eta_{II} = \frac{\text{Minimum work input}}{\text{Actual work input}} = \frac{101.8}{115.7}$$

$$= 0.88 \text{ or } 88\% \quad \text{Ans.}$$

REVIEW QUESTIONS

- 8.1 What do you understand by high grade energy and low grade energy?
- 8.2 What is available energy and unavailable energy?
- 8.3 Who propounded the concept of availability?

- 8.4 What is the available energy referred to a cycle?
- 8.5 Show that there is a decrease in available energy when heat is transferred through a finite temperature difference.
- 8.6 Deduce the expression for available energy from a finite energy source at temperature T when the environmental temperature is T_0 .
- 8.7 What do you understand by exergy and energy?
- 8.8 What is meant by quality of energy?
- 8.9 Why is exergy of a fluid at a higher temperature more than that at a lower temperature?
- 8.10 How does the exergy value provide a useful measure of the quality of energy?
- 8.11 Why is the second law called the law of degradation of energy?
- 8.12 Energy is always conserved, but its quality is always degraded. Explain.
- 8.13 Why is the work done by a closed system in a reversible process by interacting only with the surroundings the maximum?
- 8.14 Show that equal work is done in all reversible processes between the same end states of a system if it exchanges energy only with the surroundings.
- 8.15 Give the general expression for the maximum work of an open system which exchanges heat only with the surroundings.
- 8.16 What do you understand by Keenan function?
- 8.17 Give the expression for reversible work in a steady flow process under a given environment.
- 8.18 Give the expression for reversible work done by a closed system if it interacts only with the surroundings.
- 8.19 What do you understand by 'useful work'? Derive expressions for useful work for a closed system and a steady flow system which interact only with the surroundings.
- 8.20 What are the availability functions for a: (a) closed system, (b) steady flow system?
- 8.21 What do you understand by the dead state?
- 8.22 What is meant by availability?
- 8.23 Give expressions for availabilities of a closed system and a steady flow open system.
- 8.24 What are Helmholtz function and Gibbs function?
- 8.25 What is the availability in a chemical reaction if the temperature before and after the reaction is the same and equal to the temperature of the surroundings?
- 8.26 When is the availability of a chemical reaction equal to the decrease in the Gibbs function?
- 8.27 Derive the expression for irreversibility or exergy loss in a process executed by: (a) a closed system, (b) a steady flow system, in a given environment.
- 8.28 State and explain the Gouy-Stodola theorem.
- 8.29 How is heat transfer through a finite temperature difference equivalent to the destruction of its availability?
- 8.30 Considering the steady and adiabatic flow of an ideal gas through a pipe, show that the rate of decrease in availability or lost work is proportional to the pressure drop and the mass flow rate.
- 8.31 What do you understand by Grassman diagram?
- 8.32 What is entropy generation number?
- 8.33 Why is exergy always a positive value? Why cannot it be negative?

- 8.34 Why and when is exergy completely destroyed?
- 8.35 Give the exergy balance for a closed system.
- 8.36 Explain the statement: The exergy of an isolated system can never increase. How is it related to the principle of increase of entropy?
- 8.37 Give the exergy balance of a steady flow system.
- 8.38 Define the second law efficiency. How is it different from the first law efficiency in the case of a simple power plant?
- 8.39 Derive the second law efficiency for: (a) a solar water heater, and (b) a heat pump.
- 8.40 What is meant by energy cascading? How is it thermodynamically efficient?
- 8.41 Derive expressions for the irreversibility and second law efficiency of a: (a) steam turbine, (b) compressor, (c) heat exchanger, and (d) mixer.
- 8.42 What is the deficiency of the first law efficiency? How does the second law efficiency make up this deficiency?
- 8.43 How can you improve the first law efficiency and the second law efficiency?

PROBLEMS

- 8.1 What is the maximum useful work which can be obtained when 100 kJ are abstracted from a heat reservoir at 675 K in an environment at 288 K? What is the loss of useful work if (a) a temperature drop of 50°C is introduced between the heat source and the heat engine, on the one hand, and the heat engine and the heat sink, on the other, (b) the source temperature drops by 50°C and the sink temperature rises by 50°C during the heat transfer process according to the linear

$$\text{law } \frac{dT}{T} = \pm \text{constant?}$$

Ans. 57.38 kJ, (a) 11.46 kJ, (b) 5.5 kJ

- 8.2 In a steam generator, water is evaporated at 260°C, while the combustion gas ($c_p = 1.08 \text{ kJ/kg K}$) is cooled from 1300°C to 320°C. The surroundings are at 30°C. Determine the loss in available energy due to the above heat transfer per kg of water evaporated. (Latent heat of vaporization of water at 260°C = 1662.5 kJ/kg.)

Ans. 443.6 kJ

- 8.3 Exhaust gases leave an internal combustion engine at 800°C and 1 atm, after having done 1050 kJ of work per kg of gas in the engine (c_p of gas = 1.1 kJ/kg K). The temperature of the surroundings is 30°C. (a) How much available energy per kg of gas is lost by throwing away the exhaust gases? (b) What is the ratio of the lost available energy to the engine work?

Ans. (a) 425.58 kJ, (b) 0.405

- 8.4 A hot spring produces water at a temperature of 56°C. The water flows into a large lake, with a mean temperature of 14°C, at a rate of 0.1 m³ of water per min. What is the rate of working of an ideal heat engine which uses all the available energy?

Ans. 19.5 kW

- 8.5 0.2 kg of air at 300°C is heated reversibly at constant pressure to 2066 K. Find the available and unavailable energies of the heat added. Take $T_0 = 30^\circ\text{C}$ and $c_p = 1.0047 \text{ kJ/kg K}$.

Ans. 211.9 and 78.1 kJ

- 8.6 Eighty kg of water at 100°C are mixed with 50 kg of water at 60°C , while the temperature of the surroundings is 15°C . Determine the decrease in available energy due to mixing.

Ans. 240 kJ

- 8.7 A lead storage battery used in an automobile is able to deliver 5.2 MJ of electrical energy. This energy is available for starting the car.

Let compressed air be considered for doing an equivalent amount of work in starting the car. The compressed air is to be stored at 7 MPa, 25°C . What is the volume of the tank that would be required to let the compressed air have an availability of 5.2 MJ? For air, $pv = 0.287 T$, where T is in K, p in kPa, and v in m^3/kg .

Ans. 0.228 m^3

- 8.8 Ice is to be made from water supplied at 15°C by the process shown in Fig. P 8.8. The final temperature of the ice is -10°C , and the final temperature of the water that is used as cooling water in the condenser is 30°C . Determine the minimum work required to produce 1000 kg of ice. Take c_p for water = 4.187 kJ/kgK , c_p for ice = 2.093 kJ/kgK , and latent heat of fusion of ice = 334 kJ/kg .

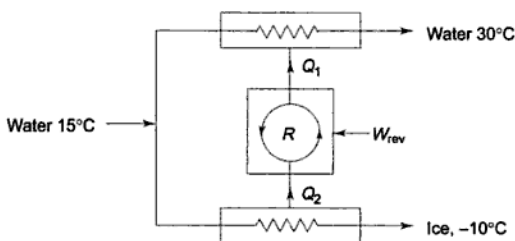

Fig. P 8.8

Ans. 31.92 MJ

- 8.9 A pressure vessel has a volume of 1 m^3 and contains air at 1.4 MPa, 175°C . The air is cooled to 25°C by heat transfer to the surroundings at 25°C . Calculate the availability in the initial and final states and the irreversibility of this process. Take $p_0 = 100 \text{ kPa}$.

Ans. 135 kJ/kg, 114.6 kJ/kg, 223 kJ

- 8.10 Air flows through an adiabatic compressor at 2 kg/s. The inlet conditions are 1 bar and 310 K and the exit conditions are 7 bar and 560 K. Compute the net rate of availability transfer and the irreversibility. Take $T_0 = 298 \text{ K}$.

Ans. 481.1 kW and 21.2 kW

- 8.11 An adiabatic turbine receives a gas ($c_p = 1.09$ and $c_v = 0.838 \text{ kJ/kg K}$) at 7 bar and 1000°C and discharges at 1.5 bar and 665°C . Determine the second law and isentropic efficiencies of the turbine. Take $T_0 = 298 \text{ K}$.

Ans. 0.956, 0.879

- 8.12 Air enters an adiabatic compressor at atmospheric conditions of 1 bar, 15°C and leaves at 5.5 bar. The mass flow rate is 0.01 kg/s and the efficiency of the compressor is 75%. After leaving the compressor, the air is cooled to 40°C in an

aftercooler. Calculate (a) the power required to drive the compressor, and (b) the rate of irreversibility for the overall process (compressor and cooler).

Ans. (a) 2.42 kW, (b) 1 kW

- 8.13 In a rotary compressor, air enters at 1.1 bar, 21°C where it is compressed adiabatically to 6.6 bar, 250°C. Calculate the irreversibility and the entropy production for unit mass flow rate. The atmosphere is at 1.03 bar, 20°C. Neglect the K.E. changes.

Ans. 19 kJ/kg, 0.064 kJ/kg K

- 8.14 In a steam boiler, the hot gases from a fire transfer heat to water which vaporizes at a constant temperature of 242.6°C (3.5 MPa). The gases are cooled from 1100 to 430°C and have an average specific heat, $c_p = 1.046$ kJ/kg K over this temperature range. The latent heat of vaporization of steam at 3.5 MPa is 1753.7 kJ/kg. If the steam generation rate is 12.6 kg/s and there is negligible heat loss from the boiler, calculate: (a) the rate of heat transfer, (b) the rate of loss of exergy of the gas, (c) the rate of gain of exergy of the steam, and (d) the rate of entropy generation. Take $T_0 = 21^\circ\text{C}$.

Ans. (a) 22096 kW, (b) 15605.4 kW (c) 9501.0 kW, (d) 20.76 kW/K

- 8.15 An economizer, a gas-to-water finned tube heat exchanger, receives 67.5 kg/s of gas $c_p = 1.0046$ kJ/kg K, and 51.1 kg/s of water, $c_p = 4.186$ kJ/kg K. The water rises in temperature from 402 to 469 K, where the gas falls in temperature from 682 to 470 K. There are no changes of kinetic energy, and $p_0 = 1.03$ bar and $T_0 = 289$ K. Determine: (a) rate of change of availability of the water, (b) the rate of change of availability of the gas, and (c) the rate of entropy generation.

Ans. (a) 4802.2 kW, (b) 7079.8 kW, (c) 7.73 kW/K

- 8.16 The exhaust gases from a gas turbine are used to heat water in an adiabatic counterflow heat exchanger. The gases are cooled from 260 to 120°C, while water enters at 65°C. The flow rates of the gas and water are 0.38 kg/s and 0.50 kg/s respectively. The constant pressure specific heats for the gas and water are 1.09 and 4.186 kJ/kg K respectively. Calculate the rate of exergy loss due to heat transfer. Take $T_0 = 35^\circ\text{C}$.

Ans. 11.92 kW

- 8.17 The exhaust from a gas turbine at 1.12 bar, 800 K flows steadily into a heat exchanger which cools the gas to 700 K without significant pressure drop. The heat transfer from the gas heats an air flow at constant pressure, which enters the heat exchanger at 470 K. The mass flow rate of air is twice that of the gas and the surroundings are at 1.03 bar, 20°C. Determine: (a) the decrease in availability of the exhaust gases, and (b) the total entropy production per kg of gas. (c) What arrangement would be necessary to make the heat transfer reversible and how much would this increase the power output of the plant per kg of turbine gas? Take c_p for exhaust gas as 1.08 and for air as 1.05 kJ/kg K. Neglect heat transfer to the surroundings and the changes in kinetic and potential energy.

Ans. (a) 66 kJ/kg, (b) 0.0731 kJ/kg K, (c) 38.7 kJ/kg

- 8.18 An air preheater is used to heat up the air used for combustion by cooling the outgoing products of combustion from a furnace. The rate of flow of the products is 10 kg/s, and the products are cooled from 300°C to 200°C, and for the products at this temperature $c_p = 1.09$ kJ/kg K. The rate of air flow is 9 kg/s, the initial air temperature is 40°C, and for the air $c_p = 1.005$ kJ/kg K.

(a) What is the initial and final availability of the products?

- (b) What is the irreversibility for this process?
 (c) If the heat transfer from the products were to take place reversibly through heat engines, what would be the finally temperature of the air? What power would be developed by the heat engines? Take $T_0 = 300$ K.

Ans (a) 85.97, 39.68 kJ/kg, (b) 256.5 kW, (c) 394.41 K, 353.65 kW

- 8.19 A mass of 2 kg of air in a vessel expands from 3 bar, 70°C to 1 bar, 40°C, while receiving 1.2 kJ of heat from a reservoir at 120°C. The environment is at 0.98 bar, 27°C. Calculate the maximum work and the work done on the atmosphere.

Ans. 177 kJ, 112.5 kJ

- 8.20 Air enters the compressor of a gas turbine at 1 bar, 30°C and leaves the compressor at 4 bar. The compressor has an efficiency of 82%. calculate per kg of air (a) the work of compression, (b) the reversible work of compression, and (c) the irreversibility. [For air, use

$$\frac{T_{2s}}{T_1} = \left(\frac{P_2}{P_1}\right)^{\gamma-1/\gamma}$$

where T_{2s} is the temperature of air after isentropic compression and $\gamma = 1.4$. The compressor efficiency is defined as $(T_{2s} - T_1)/(T_2 - T_1)$, where T_2 is the actual temperature of air after compression.]

Ans. (a) 180.5 kJ/kg, (b) 159.5 kJ/kg (c) 21 kJ/kg

- 8.21 A mass of 6.98 kg of air is in a vessel at 200 kPa, 27°C. Heat is transferred to the air from a reservoir at 727°C until the temperature of air rises to 327°C. The environment is at 100kPa, 17°C. Determine (a) the initial and final availability of air, (b) the maximum useful work associated with the process.

Ans. (a) 103.5, 621.9 kJ (b) 582 kJ

- 8.22 Air enters an adiabatic compressor in steady flow at 140 kPa, 17°C and 70 m/s and leaves it at 350 kPa, 127°C and 110 m/s. The environment is at 100 kPa, 7°C. Calculate per kg of air (a) the actual amount of work required, (b) the minimum work required, and (c) the irreversibility of the process.

Ans. (a) 114.4 kJ, (b) 97.3 kJ, (c) 17.1 kJ

- 8.23 Air expands in a turbine adiabatically from 500 kPa, 400 K and 150 m/s to 100 kPa, 300 K and 70 m/s. The environment is at 100 kPa, 17°C. Calculate per kg of air (a) the maximum work output, (b) the actual work output, and (c) the irreversibility.

Ans. (a) 159 kJ, (b) 109 kJ, (c) 50 kJ

- 8.24 Calculate the specific exergy of air for a state at 2 bar, 393.15 K when the surroundings are at 1 bar, 293.15 K. Take $c_p = 1$ and $R = 0.287$ kJ/kg K.

Ans. 72.31 kJ/kg

- 8.25 Calculate the specific exergy of CO₂ ($c_p = 0.8659$ and $R = 0.1889$ kJ/kg K) for a state at 0.7 bar, 268.15 K and for the environment at 1.0 bar and 293.15 K.

Ans. - 18.77 kJ/kg

- 8.26 A pipe carries a stream of brine with a mass flow rate of 5 kg/s. Because of poor thermal insulation the brine temperature increases from 250 K at the pipe inlet to 253 K at the exit. Neglecting pressure losses, calculate the irreversibility rate (or rate of energy degradation) associated with the heat leakage. Take $T_0 = 293$ K and $c_p = 2.85$ kJ/kg K.

Ans. 7.05 kW

- 8.27 In an adiabatic throttling process, energy per unit mass or enthalpy remains the same. However, there is a loss of exergy. An ideal gas flowing at the rate \dot{m} is

throttled from pressure p_1 to pressure p_2 when the environment is at temperature T_0 . What is the rate of exergy loss due to throttling?

$$\text{Ans. } \dot{I} = \dot{m}RT_0 \ln \frac{p_1}{p_2}$$

- 8.28 Air at 5 bar and 20°C flows into an evacuated tank until the pressure in the tank is 5 bar. Assume that the process is adiabatic and the temperature of the surroundings is 20°C. (a) What is the final temperature of the air? (b) What is the reversible work produced between the initial and final states of the air? (c) What is the net entropy change of the air entering the tank? (d) Calculate the irreversibility of the process.

Ans. (a) 410.2 K, (b) 98.9 kJ/kg, (c) 0.3376 kJ/kg K, (d) 98.9 kJ/kg

- 8.29 A Carnot cycle engine receives and rejects heat with a 20°C temperature differential between itself and the thermal energy reservoirs. The expansion and compression processes have a pressure ratio of 50. For 1 kg of air as the working substance, cycle temperature limits of 1000 K and 300 K and $T_0 = 280$ K, determine the second law efficiency.

Ans. 0.965

- 8.30 Energy is received by a solar collector at the rate of 300 kW from a source temperature of 2400 K. If 60 kW of this energy is lost to the surroundings at steady state and if the user temperature remains constant at 600 K, what are the first law and the second law efficiencies? Take $T_0 = 300$ K.

Ans. 0.80, 0.457

- 8.31 For flow of an ideal gas through an insulated pipeline, the pressure drops from 100 bar to 95 bar. If the gas flows at the rate of 1.5 kg/s and has $c_p = 1.005$ and $c_v = 0.718$ kJ/kg K and if $T_0 = 300$ K, find the rate of entropy generation and rate of loss of exergy.

Ans. 0.0215 kW/K, 6.46 kW

- 8.32 The cylinder of an internal combustion engine contains gases at 2500°C, 58 bar. Expansion takes place through a volume ratio of 9 according to $pv^{1.38} = \text{const}$. The surroundings are at 20°C, 1.1 bar. Determine the loss of availability, the work transfer and the heat transfer per unit mass. Treat the gases as ideal having $R = 0.26$ kJ/kg K and $c_v = 0.82$ kJ/kg-K.

Ans. 1144 kJ/kg, 1074 kJ/kg, -213 kJ/kg

- 8.33 In a counterflow heat exchanger, oil ($c_p = 2.1$ kJ/kg-K) is cooled from 440 to 320 K, while water ($c_p = 4.2$ kJ/kg K) is heated from 290 K to temperature T . The respective mass flow rates of oil and water are 800 and 3200 kg/h. Neglecting pressure drop, KE and PE effects and heat loss, determine (a) the temperature T , (b) the rate of exergy destruction, (c) the second law efficiency. Take $T_0 = 17^\circ\text{C}$ and $p_0 = 1$ atm.

Ans. (a) 305 K, (b) 41.4 MJ/h, (c) 10.9%

- 8.34 Oxygen enters a nozzle operating at steady state at 3.8 MPa, 387°C and 10 m/s. At the nozzle exit the conditions are 150 kPa, 37°C and 750 m/s. Determine (a) the heat transfer per kg and (b) the irreversibility. Assume oxygen as an ideal gas, and take $T_0 = 20^\circ\text{C}$, $p_0 = 1$ atm.

Ans. (a) -37.06 kJ/kg, (b) 81.72 kJ/kg

- 8.35 Argon gas expands adiabatically in a turbine from 2 MPa, 1000°C to 350 kPa. The mass flow rate is 0.5 kg/s and the turbine develops power at the rate of

120 kW. Determine (a) the temperature of argon at the turbine exit, (b) the irreversibility rate, and (c) the second law efficiency. Neglect KE and PE effects and take $T_0 = 20^\circ\text{C}$, $p_0 = 1$ atm.

Ans. (a) 538.1°C , (b) 18.78 kW, (c) 86.5%

- 8.36 In the boiler of a power plant are tubes through which water flows as it is brought from 0.8 MPa, 150°C ($h = 632.6$ kJ/kg, $s = 1.8418$ kJ/kg K) to 0.8 MPa, 250°C ($h = 2950$ kJ/kg, $s = 7.0384$ kJ/kg K). Combustion gases passing over the tubes cool from 1067°C to 547°C . These gases may be considered as air (ideal gas) having $c_p = 1.005$ kJ/kg K. Assuming steady state and neglecting any heat loss, and KE and PE effects, determine (a) the mass flow rate of combustion gases per kg of steam, (b) the loss of exergy per kg steam, and (c) the second law efficiency. Take $T_0 = 25^\circ\text{C}$, $p_0 = 1$ atm.

Ans. (a) $m_g/m_w = 4.434$, (b) 802.29 kJ/kg steam, (c) 48.9%

- 8.37 Air enters a hair dryer at 22°C , 1 bar with a velocity of 3.7 m/s and exits at 83°C , 1 bar with a velocity of 9.1 m/s through an area of 18.7 cm². Neglecting any heat loss and PE effect and taking $T_0 = 22^\circ\text{C}$, (a) evaluate the power required in kW, and (b) devise and evaluate a second law efficiency.

Ans. (a) -1.02 kW, (b) 9%

- 8.38 An isolated system consists of two solid blocks. One block has a mass of 5 kg and is initially at 300°C . The other block has a mass of 10 kg and is initially at -50°C . The blocks are allowed to come into thermal equilibrium. Assuming the blocks are incompressible with constant specific heats of 1 and 0.4 kJ/kgK, respectively, determine (a) the final temperature, (b) the irreversibility. Take $T_0 = 300$ K.

Ans. (a) 417.4 K, (b) 277 kJ

- 8.39 Air flows into a heat engine at ambient conditions 100 kPa, 300 K. Energy is supplied as 1200 kJ per kg air from a 1500 K source and in some part of the process, a heat loss of 300 kJ/kg air happens at 750 K. The air leaves the engine at 100 kPa, 800K. Find the first and the second law efficiencies.

Ans. 0.315, 0.672

- 8.40 Consider two rigid containers each of volume 1 m³ containing air at 100 kPa, 400K. An internally reversible Carnot heat pump is then thermally connected between them so that it heats one up and cools the other down. In order to transfer heat at a reasonable rate, the temperature difference between the working fluid inside the heat pump and the air in the containers is set to 20°C . The process stops when the air in the coldest tank reaches 300K. Find the final temperature of the air that is heated up, the work input to the heat pump, and the overall second law efficiency.

Ans. 550 K, 31.2 kJ, 0.816

9

Properties of Pure Substances

A pure substance is a substance of constant chemical composition throughout its mass. It is a one-component system. It may exist in one or more phases.

9.1 p - v Diagram for a Pure Substance

Assume a unit mass of ice (solid water) at -10°C and 1 atm contained in a cylinder and piston machine (Fig. 9.1). Let the ice be heated slowly so that its temperature is always uniform. The changes which occur in the mass of water would be traced as the temperature is increased while the pressure is held constant. Let the state changes of water be plotted on p - v coordinates. The distinct regimes of heating, as shown in Fig. 9.2, are:

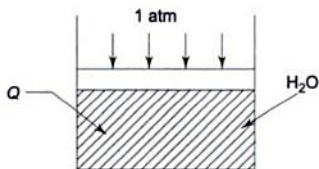

Fig. 9.1 Heating of H_2O at a constant pressure of 1 atm

1-2 The temperature of ice increases from -10°C to 0°C . The volume of ice would increase, as would be the case for any solid upon heating. At state 2, i.e. 0°C , the ice would start melting.

2-3 Ice melts into water at a constant temperature of 0°C . At state 3, the melting process ends. *There is a decrease in volume, which is a peculiarity of water.*

3-4 The temperature of water increases, upon heating, from 0°C to 100°C . The volume of water increases because of thermal expansion.

4-5 The water starts boiling at state 4 and boiling ends at state 5. This phase change from liquid to vapour occurs at a constant temperature of 100°C (the pressure being constant at 1 atm). There is a large increase in volume.

5-6 The vapour is heated to, say, 250°C (state 6). The volume of vapour increases from v_5 to v_6 .

Water existed in the solid phase between 1 and 2, in the liquid phase between 3 and 4, and in the gas phase beyond 5. Between 2 and 3, the solid changed into the liquid phase by absorbing the latent heat of fusion and between 4 and 5, the liquid changed into the vapour phase by absorbing the latent heat of vaporization, both at constant temperature and pressure.

The states 2, 3, 4 and 5 are known as *saturation states*. A saturation state is a state from which a change of phase may occur without a change of pressure or temperature. State 2 is a *saturated solid state* because a solid can change into liquid at constant pressure and temperature from state 2. States 3 and 4 are both saturated liquid states. In state 3, the liquid is saturated with respect to solidification, whereas in state 4, the liquid is saturated with respect to vaporization. State 5 is a *saturated vapour state*, because from state 5, the vapour can condense into liquid without a change of pressure or temperature.

If the heating of ice at -10°C to steam at 250°C were done at a constant pressure of 2 atm, similar regimes of heating would have been obtained with similar saturation states 2, 3, 4 and 5, as shown in Fig. 9.2. All the state changes of the system can similarly be plotted on the p - v coordinates, when it is heated at different constant pressures. All the saturated solid states 2 at various pressures are joined by a line, as shown in Fig. 9.3.

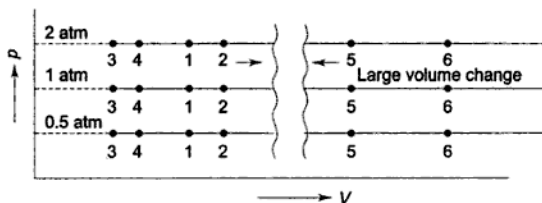

Fig. 9.2 Changes in the volume of water during heating at constant pressure

Similarly, all the saturated liquid states 3 with respect to solidification, all the saturated liquid states 4 with respect to vaporization, and all the saturated vapour states 5, are joined together.

Figure 9.4 shows state changes of a pure substance other than water whose volume increases on melting.

The line passing through all the saturated solid states 2 (Figs 9.3 and 9.4) is called the *saturated solid line*. The lines passing through all the saturated liquid states 3 and 4 with respect to solidification and vaporization respectively are

known as the *saturated liquid lines*, and the line passing through all the saturated vapour states 5, is the *saturated vapour line*. The saturated liquid line with respect to vaporization and the saturated vapour line incline towards each other and form what is known as the *saturation or vapour dome*. The two lines meet at the *critical state*.

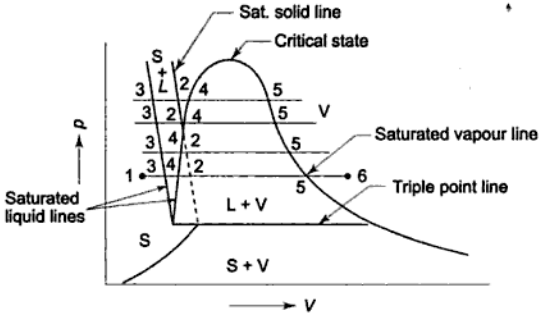

Fig. 9.3 p - v diagram of water, whose volume decreases on melting

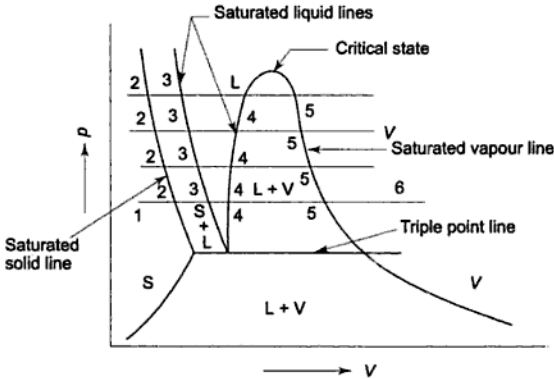

Fig. 9.4 p - v diagram of a pure substance other than water, whose volume increases on melting

To the left of the saturated solid line is the solid (S) region (Fig. 9.4). Between the saturated solid line and saturated liquid line with respect to solidification there exists the *solid-liquid mixture ($S + L$)* region. Between the two saturated liquid lines is the *compressed liquid region*. The *liquid-vapour mixture region ($L + V$)* exists within the vapour dome between the saturated liquid and saturated vapour lines. To the right of the saturated vapour line is the *vapour region*. The *triple point* is a line on the p - v diagram, where all the three phases, solid, liquid

and gas, exit in equilibrium. At a pressure below the triple point line, the substance cannot exist in the liquid phase, and the substance, when heated, transforms from solid to vapour (known as sublimation) by absorbing the latent heat of sublimation from the surroundings. The region below the triple point line is, therefore, the *solid-vapour (S + V) mixture region*. Table 9.1 gives the triple point data for a number of substances.

Table 9.1 Triple-Point Data

Substance	Temperature, K	Pressure, mm Hg
Acetylene, C ₂ H ₂	192.4	962
Ammonia, NH ₃	195.42	45.58
Argon, A	83.78	515.7
Carbon dioxide, CO ₂	216.55	3885.1
Carbon monoxide, CO	68.14	115.14
Methane, C ₂ H ₆	89.88	0.006
Ethylene, C ₂ H ₄	104.00	0.9
Hydrogen, H ₂	13.84	52.8
Methane, CH ₄	90.67	87.7
Nitrogen, N ₂	63.15	94.01
Oxygen, O ₂	54.35	1.14
Water, H ₂ O	273.16	4.587

Liquid is, most often, the working fluid in power cycles, etc. and interest is often confined to the liquid-vapour regions only. So to locate the state points, the solid regions from Figs 9.3 and 9.4 can be omitted. The p - v diagram then becomes as shown in Fig. 9.5. If the vapour at state A is compressed slowly and isothermally, the pressure will rise until there is saturated vapour at point B . If the compression is continued, condensation takes place, the pressure remaining constant so long as the temperature remains constant. At any point between B and C , the liquid and vapour are in equilibrium. Since a very large increase in pressure is needed to compress the liquid, line CD is almost vertical. $ABCD$ is a typical *isotherm* of a pure substance on a p - v diagram. Some isotherms are shown in Fig. 9.5. As the temperature increases, the liquid-vapour transition, as represented by BC , decreases, and becomes zero at the critical point. Below the critical point only, there is a liquid-vapour transition zone, where a saturated liquid, on heating, absorbs the latent heat of vaporization, and becomes saturated vapour at a constant pressure and temperature. Similarly, a saturated vapour, on cooling, releases the latent heat of condensation at constant pressure and temperature to become saturated liquid. Above the critical point, however, a liquid, upon heating, suddenly *flashes* into vapour, or a vapour, upon cooling, suddenly condenses into liquid. There is no distinct transition zone from liquid to vapour and vice versa. The isotherm passing through the critical point is called the *critical isotherm*, and the corresponding temperature is known as the *critical temperature* (t_c). The pressure and volume at the critical point are known as the *critical pressure* (p_c) and the *critical volume* (v_c) respectively. For water

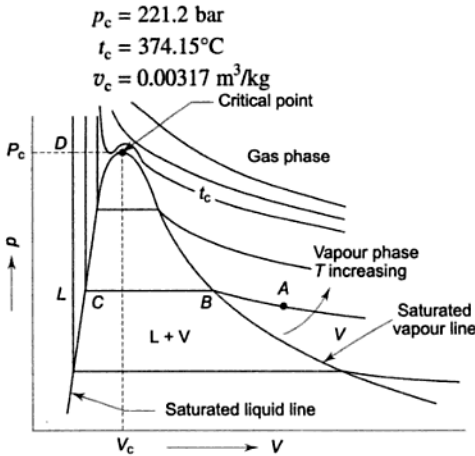

Fig. 9.5 Saturation curve on p - v diagram

The critical point data of certain substances are given in Appendix F. Above the critical point, the isotherms are continuous curves that at large volumes and low pressures approach equilateral hyperbolas.

When a liquid or solid is in equilibrium with its vapour at a given temperature, the vapour exerts a pressure that depends only on the temperature (Fig. 9.6). In general, the greater the temperature, the higher is the *vapour pressure*. The temperature at which the vapour pressure is equal to 760 mm Hg is called the *normal boiling point*.

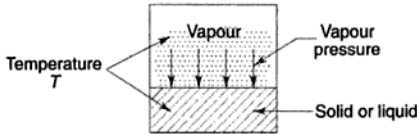

Fig. 9.6 Vapour pressure

Phase change occurs at constant pressure and temperature. A pure liquid at a given pressure will transform into vapour only at a particular temperature, known as *saturation temperature*, which is a function of pressure. Similarly, if the temperature is fixed, the liquid will boil (or condense) only at a particular pressure, called the *saturation pressure*, which is a function of temperature. In Fig. 9.7, if p_1 is the pressure, the corresponding saturation temperature is $(t_{\text{sat}})_1$, or if t_2 is the given temperature, the saturation pressure is $(p_{\text{sat}})_2$. As the pressure increases, the saturation temperature increases. Saturation states exist up to the critical point. At point A, the liquid starts boiling, and at point B, the boiling gets completed. At A, it is all liquid (saturated) and there is no vapour, while at B, it is all vapour (saturated) and there is no liquid. Vapour content progressively increases as the liquid changes its state from A towards B.

If u_v is the specific volume of the saturated liquid at a given pressure, and v_g the specific volume of the saturated vapour, then $(v_g - v_f)$ or v_{fg} is the change in specific volume during phase transition (boiling or condensation) at that pressure. As pressure increases, v_{fg} decreases, and at the critical point v_{fg} becomes zero.

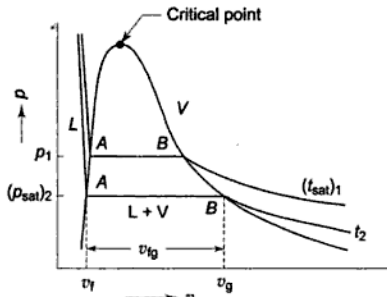

Fig. 9.7 Saturation pressure and temperature

9.2 p - T Diagram for a Pure Substance

The state changes of a pure substance, upon slow heating at different constant pressures, are shown on the p - v plane, in Figs 9.2, 9.3, and 9.4. If these state changes are plotted on p - T coordinates, the diagram, as shown in Fig. 9.8, will be obtained. If the heating of ice at -10°C to steam at 250°C at the constant pressure of 1 atm is considered, 1-2 is the solid (ice) heating, 2-3 is the melting of ice at 0°C , 3-4 is the liquid heating, 4-5 is the vaporization of water at 100°C , and 5-6 is the heating in the vapour phase. The process will be reversed from state 6 to state 1 upon cooling. The curve passing through the 2, 3 points is called the *fusion curve*, and the curve passing through the 4, 5 points (which indicate the vaporization or condensation at different temperatures and pressures) is called

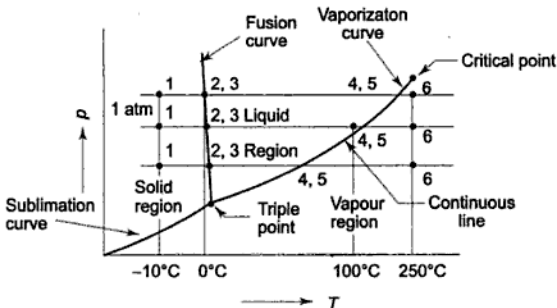

Fig. 9.8 Phase equilibrium diagram on p - T coordinates

the *vaporization curve*. If the vapour pressure of a solid is measured at different temperatures, and these are plotted, the *sublimation curve* will be obtained. The fusion curve, the vaporization curve, and the sublimation curve meet at triple point.

The slopes of the sublimation and vaporization curves for all substances are positive. The slope of the fusion curve for most substances is positive, but for water, it is negative. The temperature at which a liquid boils is very sensitive to pressure, as indicated by the vaporization curve which gives the saturation temperatures at different pressures, but the temperature at which a solid melts is not such a strong function of pressure, as indicated by the small slope of the fusion curve.

The triple point of water is at 4.58 mm Hg and 273.16 K, whereas that of CO_2 is at 3885 mm Hg (about 5 atm) and 216.55 K. So when solid CO_2 ('dry ice') is exposed to 1 atm pressure, it gets transformed into vapour directly, absorbing the latent heat of sublimation from the surroundings, which gets cooled or 'refrigerated'.

9.3 p - v - T Surface

The relationships between pressure, specific volume, and temperature can be clearly understood with the aid of a three-dimensional p - v - T surface. Figure 9.9 illustrates a substance like water that expands upon freezing and Fig. 9.10 illustrates substances other than water which contract upon freezing. The projections on the p - T and p - v planes are also shown in these figures. Any point on the p - v - T surface represents an equilibrium state of the substance. The triple point line when projected to the p - T plane becomes a point. The critical isotherm has a point of inflection at the critical point.

9.4 T - s Diagram for a Pure Substance

The heating of the system of 1 kg of ice at -5°C to steam at 250°C is again considered, the pressure being maintained constant at 1 atm. The entropy increases of the system in different regimes of heating are given below.

1. The entropy increase of ice as it is heated from -5°C to 0°C at 1 atm. ($c_{p,\text{ice}} = 2.093 \text{ kJ/kg K}$).

$$\begin{aligned}\Delta s_1 &= s_2 - s_1 = \int \frac{dQ}{T} = \int_{T_1=268}^{T_2=273} \frac{m c_p dT}{T} = c_p \ln \frac{273}{268} \\ &= 2.093 \ln \frac{273}{268} = 0.0398 \text{ kJ/kg K}.\end{aligned}$$

2. The entropy increase of ice as it melts into water at 0°C (latent heat of fusion of ice = 334.96 kJ/kg)

$$\Delta s_2 = s_3 - s_2 = \frac{334.96}{273} = 1.23 \text{ kJ/kg K}$$

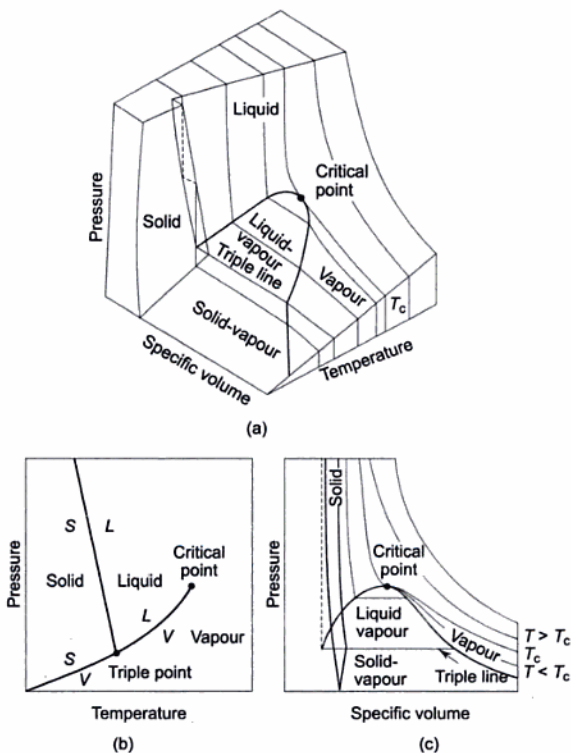

Fig. 9.9 $p-v-T$ surface and projections for a substance that expands on freezing
 (a) Three-dimensional view (b) Phase diagram (c) $p-v$ diagram

3. The entropy increase of water as it is heated from 0°C to 100°C
 ($c_{p\text{ water}} = 4.187 \text{ kJ/kg K}$)

$$\Delta s_3 = s_4 - s_3 = c_p \ln \frac{T_3}{T_2} = 4.187 \ln \frac{373}{273}$$

$$= 1.305 \text{ kJ/kg K}$$

4. The entropy increase of water as it is vaporized at 100°C , absorbing the latent heat of vaporization (2257 kJ/kg)

$$\Delta s_4 = s_5 - s_4 = \frac{2257}{273} = 6.05 \text{ kJ/kg K}$$

5. The entropy increase of vapour as it is heated from 100°C to 250°C at 1 atm

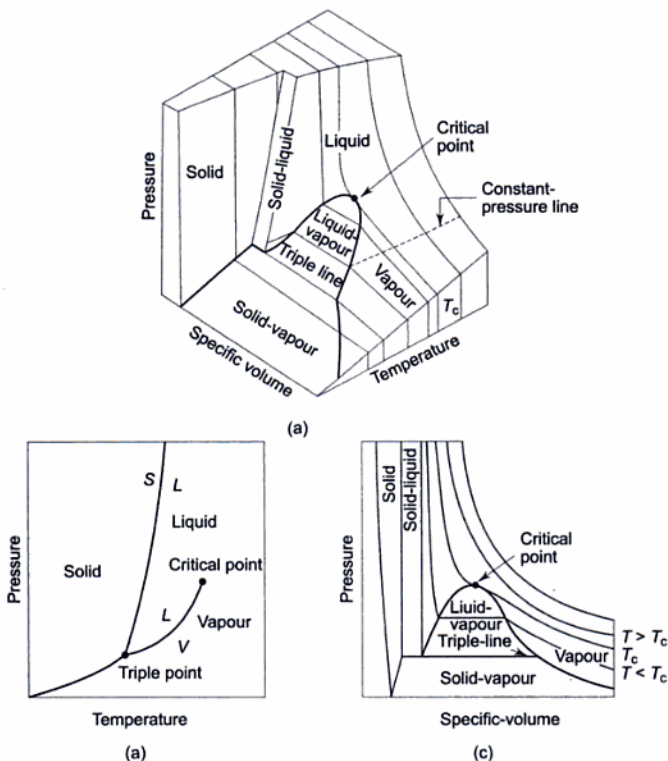
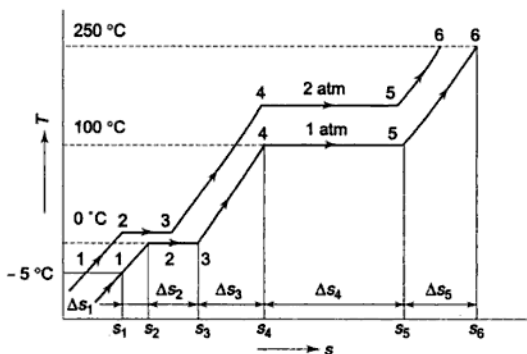
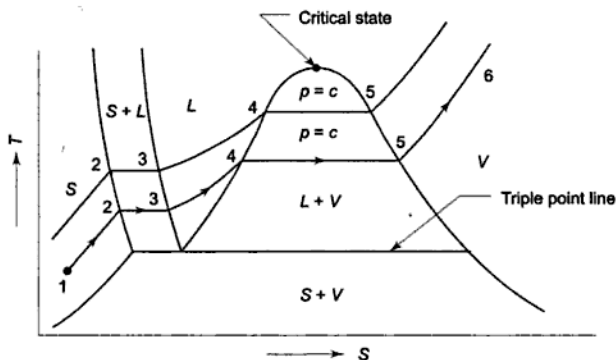

Fig. 9.10 p - v - T surface and projections for a substance that contracts on freezing
 (a) Three-dimensional view (b) Phase diagram (c) p - v diagram

$$\begin{aligned} \Delta s_5 = s_6 - s_5 &= \int_{373}^{523} c_p \frac{dT}{T} = 2.093 \ln \frac{523}{373} \\ &= 0.706 \text{ kJ/kg K} \end{aligned}$$

assuming the average specific heat of steam in the temperature range of 100°C to 250°C as 2.093 kJ/kg K.

These entropy changes are shown in Fig. 9.11. The curve 1-2-3-4-5-6 is the isobar of 1 atm. If, during the heating process, the pressure had been maintained constant at 2 atm, a similar curve would be obtained. The states 2, 3, 4, and 5 are saturation states. If these states for different pressures are joined, as in Figs 9.3 and 9.4, the phase equilibrium diagram of a pure substance on the T - s coordinates, as shown in Fig. 9.12, would be obtained.

Fig. 9.11 Isobars on T - s plotFig. 9.12 Phase equilibrium diagram on T - s coordinates

Most often, liquid-vapour transformations only are of interest, and Fig. 9.13 shows the liquid, the vapour, and the transition zones only. At a particular pressure, s_f is the specific entropy of saturated water, and s_g is that of saturated vapour. The entropy change of the system during the phase change from liquid to vapour at that pressure is s_{fg} ($=s_g - s_f$). The value of s_{fg} decreases as the pressure increases, and becomes zero at the critical point.

9.5 h - s Diagram or Mollier Diagram for a Pure Substance

From the first and second laws of thermodynamics, the following property relation was obtained.

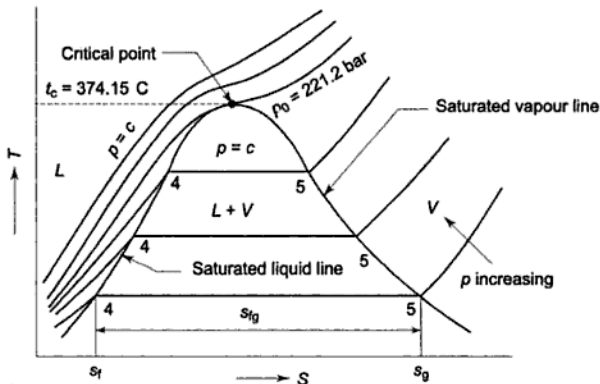

Fig. 9.13 Saturation (or vapour) dome for water

$$Tds = dh - vdp$$

$$\text{or} \quad \left(\frac{\partial h}{\partial s} \right)_p = T \quad (9.1)$$

This equation forms the basis of the h - s diagram of a pure substance, also called the Mollier diagram. The slope of an isobar on the h - s coordinates is equal to the absolute saturation temperature ($t_{\text{sat}} + 273$) at that pressure. If the temperature remains constant the slope will remain constant. If the temperature increases, the slope of the isobar will increase.

Consider the heating of a system of ice at -5°C to steam at 250°C , the pressure being maintained constant at 1 atm. The slope of the isobar of 1 atm on the h - s coordinates (Fig. 9.14) first increases as the temperature of the ice increases from -5°C to 0°C (1-2). Its slope then remains constant as ice melts into water at the

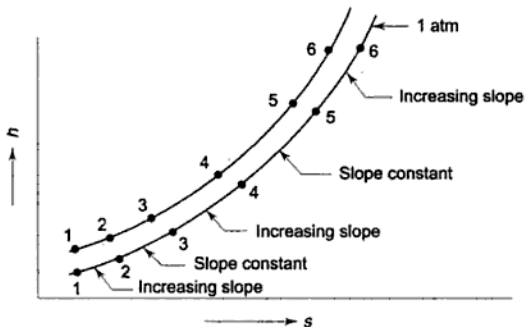
 Fig. 9.14 Isobars on h - s plot

constant temperature of 0°C (2–3). The slope of the isobar again increases as the temperature of water rises from 0°C to 100°C (3–4). The slope again remains constant as water vaporizes into steam at the constant temperature of 100°C (4–5). Finally, the slope of the isobar continues to increase as the temperature of steam increases to 250°C (5–6) and beyond. Similarly, the isobars of different pressures can be drawn on the h - s diagram as shown in Figs 9.14 and 9.15. States 2, 3, 4, and 5 are saturation states. Figure 9.15 shows the phase equilibrium diagram of a pure substance on the h - s coordinates, indicating the saturated solid line, saturated liquid lines and saturated vapour line, the various phases, and the transition (mixture) zones.

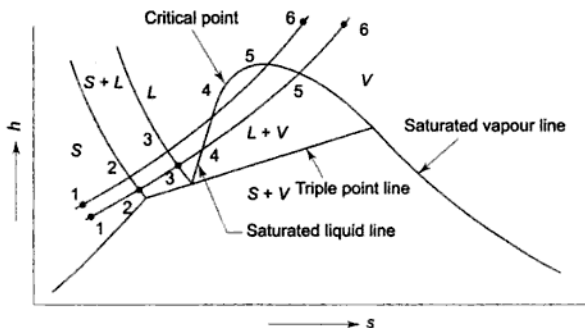

Fig. 9.15 Phase equilibrium diagram on h - s coordinates (Mollier diagram)

Figure 9.16 is the h - s or the Mollier diagram indicating only the liquid and vapour phases. As the pressure increases, the saturation temperature increases, and so the slope of the isobar also increases. Hence, the constant pressure lines diverge from one another, and the critical isobar is a tangent at the critical point, as shown. In the vapour region, the states of equal slopes at various pressures are joined by lines, as shown, which are the constant temperature lines. Although the slope of an isobar remains continuous beyond the saturated vapour line, the isotherm bends towards the right and its slope decreases asymptotically to zero, because in the ideal gas region it becomes horizontal and the constant enthalpy

implies constant temperature. $\left[\left(\frac{\partial h}{\partial s}\right)_T = T + v\left(\frac{\partial p}{\partial s}\right)_T = T - v\left(\frac{\partial T}{\partial v}\right)_p\right]$, by

Maxwell's relation, chapter 11. For an ideal gas, $\left(\frac{\partial h}{\partial s}\right)_T = T - v\frac{T}{v} = 0$. For $T = c$,

$h = c]$ At a particular pressure, h_f is the specific enthalpy of saturated water, h_g is that of saturated vapour, and h_{fg} ($= h_g - h_f$) is the latent heat of vaporization at that pressure. As the pressure increases h_{fg} decreases, and at the critical pressure, h_{fg} becomes zero.

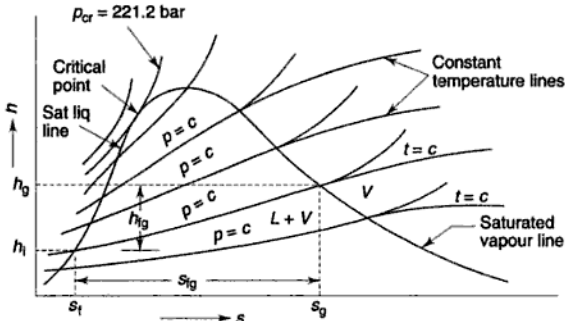

Fig. 9.16 Enthalpy-entropy diagram of water

9.6 Quality or Dryness Fraction

If in 1 kg of liquid-vapour mixture, x kg is the mass of vapour and $(1-x)$ kg is the mass of liquid, then x is known as the *quality* or dryness fraction of the liquid-vapour mixture. Therefore, quality indicates the mass fraction of vapour in a liquid vapour mixture, or

$$x = \frac{m_v}{m_v + m_l}$$

where m_v and m_l are the masses of vapour and liquid respectively in the mixture. The value of x varies between 0 and 1. For saturated water, when water just starts boiling, $x = 0$, and for saturated vapour, when vaporization is complete, $x = 1$, for which the vapour is said to be *dry saturated*.

Points m in Fig. 9.17 (a), (b), and (c) indicate the saturated liquid states with $x = 0$, and points n indicate the saturated vapour states with $x = 1$, the lines mn indicating the transition from liquid to vapour. Points a , b , and c at various pressures indicate the situations when the masses of vapour reached 25%, 50%, and 75% of the total mass, i.e. at points a , the mass of liquid is 75% and the mass of vapour is 25% of the total mass, at point b , the mixture consists of 50% liquid and 50% vapour by mass, and at points c , the mixture consists of 75% vapour and 25% liquid by mass. The lines passing through points a , b and c are the constant quality lines of 0.25, 0.50, and 0.75 respectively. Constant quality lines start from the critical point.

Let V be the total volume of a liquid vapour mixture of quality x , V_f the volume of the saturated liquid, and V_g the volume of the saturated vapour, the corresponding masses being m , m_f , and m_g respectively.

Now

$$m = m_f + m_g$$

and

$$V = V_f + V_g$$

$$mV = m_f v_f + m_g v_g$$

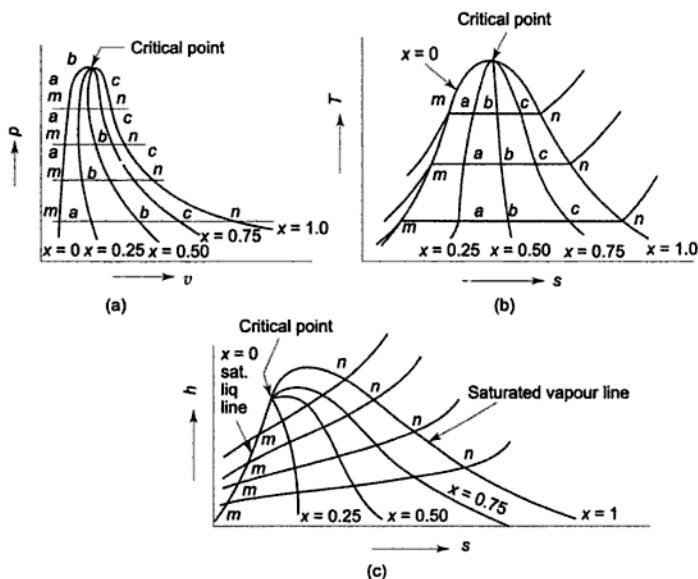

Fig. 9.17 Constant quality lines on p - v , T - s and h - s diagrams

$$\begin{aligned}
 &= (m - m_g) v_f + m_g v_g \\
 \therefore v &= \left(1 - \frac{m_g}{m}\right) v_f + \frac{m_g}{m} v_g \\
 v &= (1 - x) v_f + x v_g \quad (9.2)
 \end{aligned}$$

where $x = \frac{m_g}{m}$, v_f = specific volume of saturated liquid, v_g = specific volume of saturated vapour, and v = specific volume of the mixture of quality x . Similarly

$$s = (1 - x) s_f + x s_g \quad (9.3)$$

$$h = (1 - x) h_f + x h_g \quad (9.4)$$

$$u = (1 - x) u_f + x u_g \quad (9.5)$$

where s , h , and u refer to the mixture of quality x , the suffix f and suffix g indicate the conditions of saturated liquid and saturated vapour respectively.

From Eq. (9.2)

$$\begin{aligned}
 v &= (1 - x) v_f + x v_g \\
 &= v_f + x(v_g - v_f) \\
 &= v_f + x v_{fg}
 \end{aligned}$$

$$\text{or} \quad v = v_f + x v_{fg} \quad (9.6)$$

Similarly

$$h = h_f + x h_{fg} \quad (9.7)$$

$$s = s_f + x s_{fg} \quad (9.8)$$

$$u = u_f + x u_{fg} \quad (9.9)$$

However,

$$\rho \neq \rho_f + x \rho_{fg}$$

Volume fraction of vapour or voidage, $\alpha = v_g/v$

$$m = m_f + m_g$$

$$\rho v = \rho_f v_f + \rho_g v_g = \rho_f (v - v_g) + \rho_g v_g$$

$$\rho = (1 - \alpha)\rho_f + \alpha\rho_g \quad (9.9a)$$

9.7 Steam Tables

The properties of water are arranged in the steam tables as functions of pressure and temperature. Separate tables are provided to give the properties of water in the saturation states and in the liquid and vapour phases. The *internal energy of saturated water at the triple point ($t = 0.01^\circ\text{C}$) is arbitrarily chosen to be zero*. Since $h = u + pv$, the enthalpy of saturated water at 0.01°C is slightly positive because of the small value of (pv) term. *The entropy of saturated water is also chosen to be zero at the triple point*.

9.7.1 Saturation States

When a liquid and its vapour are in equilibrium at a certain pressure and temperature, only the pressure or the temperature is sufficient to identify the saturation state. If the pressure is given, the temperature of the mixture gets fixed, which is known as the saturation temperature, or if the temperature is given, the saturation pressure gets fixed. Saturated liquid or the saturated vapour has only one independent variable, i.e. only one property is required to be known to fix up the state. Tables A.1(a) and A.1(b) in the appendix give the properties of saturated liquid and saturated vapour. In Table A.1(a), the independent variable is temperature. At a particular temperature, the values of saturation pressure p , and v_f , v_g , h_f , h_{fg} , h_g , s_f and s_g are given, where v_f , h_f , and s_f refer to the saturated liquid states; v_g , h_g and s_g refer to the saturated vapour state; and v_{fg} , h_{fg} , and s_{fg} refer to the changes in the property values during evaporation (or condensation) at that temperature, where $v_{fg} = v_g - v_f$ and $s_{fg} = s_g - s_f$.

In Table A.1(b), the independent variable is pressure. At a particular pressure, the values of saturation temperature t , and v_f , v_g , h_f , h_{fg} , h_g , s_f , and s_g are given. Depending upon whether the pressure or the temperature is given, either Table A.1(a) or Table A.1(b) can be conveniently used for computing the properties of saturation states.

If data are required for intermediate temperatures or pressures, *linear interpolation is normally accurate*. The reason for the two tables is to reduce the amount of interpolation required.

9.7.2 Liquid-vapour Mixtures

Let us consider a mixture of saturated liquid water and water vapour in equilibrium at pressure p and temperature t . The composition of the mixture by mass will be given by its quality x , and its state will be within the vapour dome (Fig. 9.18). The properties of the mixture are as given in Article 9.6, i.e.

$$v = v_f + x v_{fg}$$

$$u = u_f + x u_{fg}$$

$$h = h_f + x h_{fg}$$

$$s = s_f + x s_{fg}$$

where v_f , v_{fg} , u_f , u_{fg} , h_f , h_{fg} , s_f and s_{fg} are the saturation properties at the given pressure and temperature.

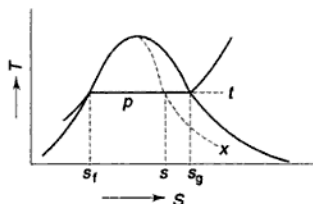

Fig. 9.18 Property in two phase region

If p or t and the quality of the mixture are given, the properties of the mixture (v , u , h , and s) can be evaluated from the above equations. Sometimes, instead of quality, one of the above properties, say, specific volume v , and pressure or temperature are given. In that case, the quality of the mixture x has to be calculated from the given v and p or t and then x being known, other properties are evaluated.

9.7.3 Superheated Vapour

When the temperature of the vapour is greater than the saturation temperature corresponding to the given pressure, the vapour is said to be *superheated* (state 1 in Fig. 9.19). The difference between the temperature of the superheated vapour and the saturation temperature at that pressure is called the *superheat* or the *degree of superheat*. As shown in Fig. 9.19, the difference $(t_1 - t_{sat})$ is the superheat.

In a superheated vapour at a given pressure, the temperature may have different values greater than the saturation temperature. Table A.2 in the appendix gives the values of the properties (volume, enthalpy, and entropy) of superheated vapour for each tabulated pair of values of pressure and temperature, both of which are now independent. Interpolation or extrapolation is to be used for pairs of values of pressure and temperature not given.

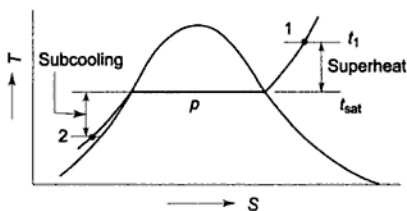

Fig. 9.19 Superheat and subcooling

9.7.4 Compressed Liquid

When the temperature of a liquid is less than the saturation temperature at the given pressure, the liquid is called *compressed liquid* (state 2 in Fig. 9.19). The pressure and temperature of compressed liquid may vary independently, and a table of properties like the superheated vapour table could be arranged to give the properties at any p and t . However, the *properties of liquids vary little with pressure*. Hence the properties are taken from the saturation tables at the temperature of the compressed liquid. When a liquid is cooled below its saturation temperature at a certain pressure it is said to be *subcooled*. The difference in saturation temperature and the actual liquid temperature is known as the degree of subcooling, or simply, subcooling (Fig. 9.17).

9.8 Charts of Thermodynamic Properties

The presentation of properties of substances in the form of a chart has certain obvious advantages. The manner of variation of properties is clearly demonstrated in the chart and there is no problem of interpolation. However, the precision is not as much as in steam tables.

The temperature-entropy plot and enthalpy-entropy plot (Fig. 9.20a) are commonly used. The temperature-entropy plot shows the vapour dome and the lines of constant pressure, constant volume, constant enthalpy, constant quality, and constant superheat. However, its scale is small and limited in use. The enthalpy-entropy plot or Mollier chart, has a larger scale to provide data suitable for many computations. It contains the same data as does the T - s chart. The Mollier chart for water is given in Appendix F.I. The Mollier diagram for steam with data taken from Keenan et al. Steam Tables (John Wiley, N. Y., 1969 is given in Fig. 9.21.)

9.9 Measurement of Steam Quality

The state of a pure substance gets fixed if two independent properties are given. A pure substance is thus said to have two degrees of freedom. Of all thermodynamic properties, it is easiest to measure the pressure and temperature of a substance. Therefore, whenever pressure and temperature are independent properties, it is

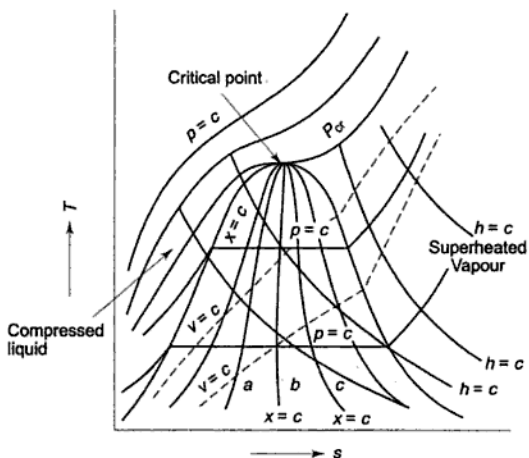

(a) Constant property lines on T-s plot

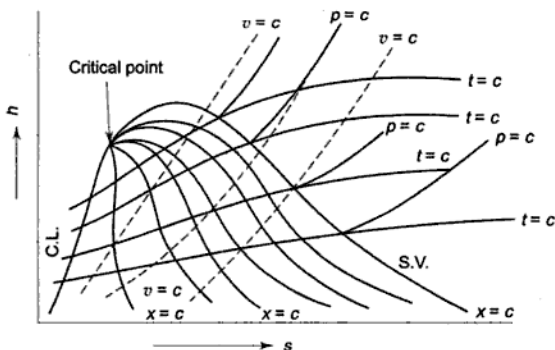

Fig. 9.20 (b) Constant property lines on Mollier diagram

the practice to measure them to determine that state of the substance. This is done in the compressed liquid region or the superheated vapour region (Fig. 9.22), where the measured values of pressure and temperature would fix up the state. But when the substance is in the saturation state or two-phase region (Fig. 9.22), the measured values of pressure and temperature could apply equally well to saturated liquid point f , saturated vapour point g , or to mixtures of any quality, points x_1 , x_2 or x_3 . Of the two properties, p and t , only one is independent; the other is a dependent property. If pressure is given, the saturation temperature gets

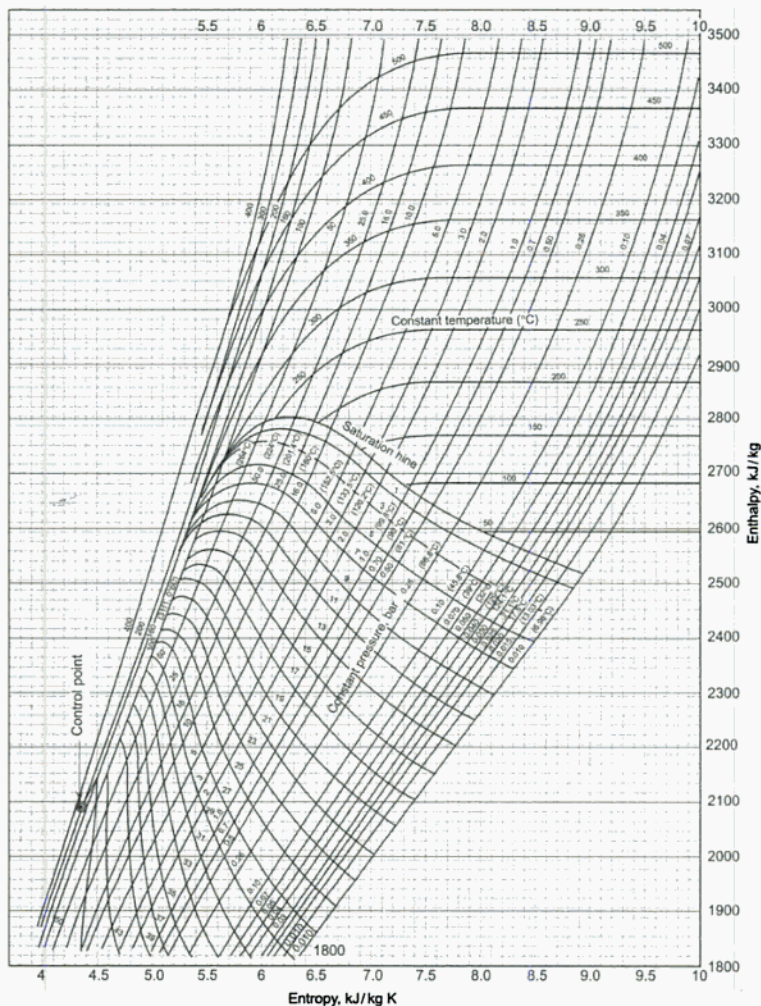

Fig. 9.21 Mollier diagram for steam (Data taken from Keenan, J.H., F.G. Keyes, P.C. Hill and J.g. Moore, *Steam Tables*, John Wiley, N.Y., 1969)

automatically fixed for the substance. In order to fix up the state of the mixture, apart from either pressure or temperature, one more property, such as specific

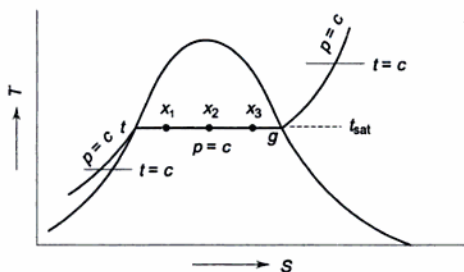

Fig. 9.22 Quality of liquid-vapour mixture

volume, enthalpy or composition of the mixture (quality) is required to be known. Since it is relatively difficult to measure the specific volume of a mixture, devices such as calorimeters are used for determining the quality or the enthalpy of the mixture.

In the measurement of quality, the object is always to bring the state of the substance from the two-phase region to the single-phase or superheated region, where both pressure and temperature are independent, and measured to fix the state, either by adiabatic throttling or electric heating.

In the *throttling calorimeter*, a sample of wet steam of mass m and at pressure p_1 is taken from the steam main through a perforated sampling tube (Fig. 9.23). Then it is throttled by the partially-opened valve (or orifice) to a pressure p_2 , measured by mercury manometer, and temperature t_2 , so that after throttling the steam is in the superheated region. The process is shown on the T - s and h - s

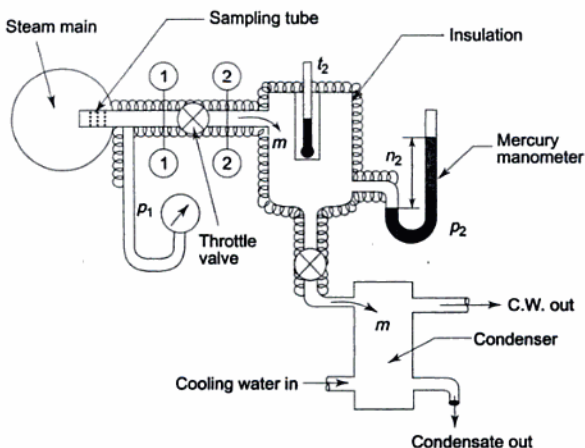

Fig. 9.23 Throttling calorimeter

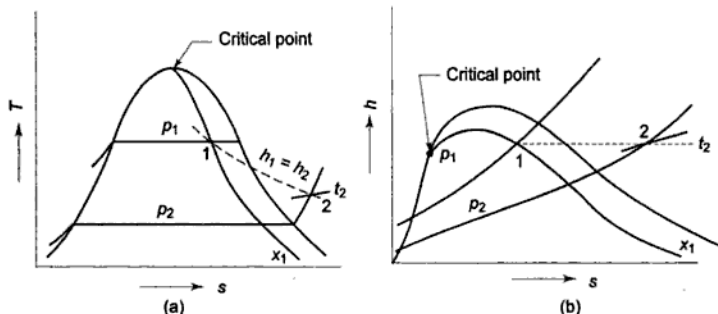

Fig. 9.24 Throttling process on T - s and h - s plots

diagrams in Fig. 9.24. The steady flow energy equation gives the enthalpy after throttling as equal to enthalpy before throttling. The initial and final equilibrium states 1 and 2 are joined by a dotted line since throttling is irreversible (adiabatic but not isentropic) and the intermediate states are non-equilibrium states not describable by thermodynamic coordinates. The initial state (wet) is given by p_1 and x_1 , and the final state by p_2 and t_2 (superheated). Now

since

$$h_1 = h_2$$

$$h_{fp1} + x_1 h_{fg1} = h_2$$

or

$$x_1 = \frac{h_2 - h_{fp1}}{h_{fg1}}$$

With p_2 and t_2 being known, h_2 can be found out from the superheated steam table. The values of h_f and h_{fg} are taken from the saturated steam table corresponding to pressure p_1 . Therefore, the quality of the wet steam x_1 can be calculated.

To be sure that steam after throttling is in the single-phase or superheated region, a minimum of 5°C superheat is desired. So if the pressure after throttling is given and the minimum 5°C superheat is prescribed, then there is the minimum quality of steam (or the maximum moisture content) at the given pressure p_1 which can be measured by the throttling calorimeter. For example, if $p_2 = 1$ atm., then $t_2 = 105^\circ\text{C}$ and the state 2 after throttling gets fixed as shown in Fig. 9.25. From state 2, the constant enthalpy line intersects the constant pressure p_1 line at 1. Therefore, the quality x_1 is the minimum quality that can be measured simply by throttling. If the quality is, say, x'_1 less than x_1 , then after throttling to $p_2 = 1$ atm., the superheat after throttling is less than 5°C . If the quality is x''_1 , then throttling to 1 atm. does not give any superheat at all.

When the steam is very wet and the pressure after throttling is not low enough to take the steam to the superheated region, then a *combined separating and throttling calorimeter* is used for the measurement of quality. Steam from the

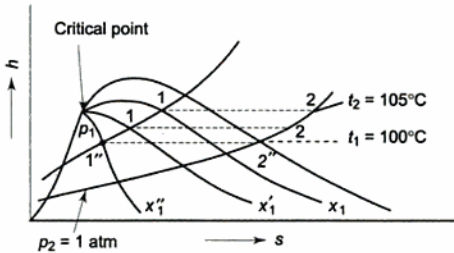

Fig. 9.25 Minimum quality that can be measured only by throttling

main is first passed through a separator (Fig. 9.26), where some part of the moisture separates out due to the sudden change in direction and falls by gravity, and the partially dry vapour is then throttled and taken to the superheated region. In Fig. 9.27, process 1–2 represents the moisture separation from the wet sample of steam at constant pressure p_1 and process 2–3 represents throttling to pressure p_2 . With p_2 and t_3 being measured, h_3 can be found out from the superheated steam table.

Now,

$$h_3 = h_2 = h_{fp1} + x_2 h_{fgp1}$$

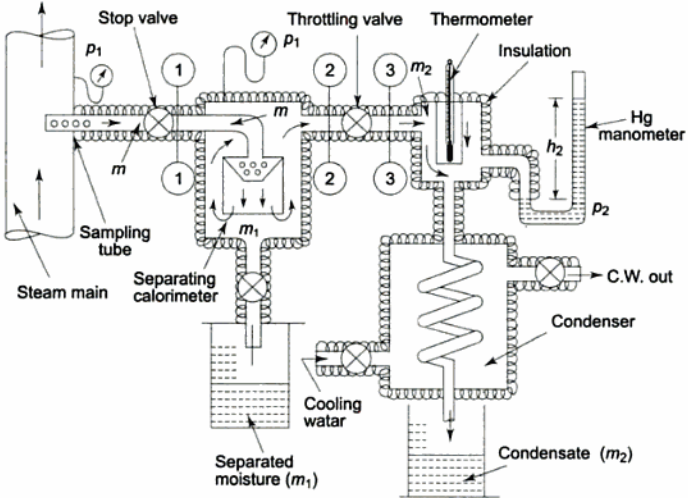

Fig. 9.26 Separating and throttling calorimeter

Therefore, x_2 , the quality of steam after partial moisture separation, can be evaluated. If m kg of steam is taken through the sampling tube in t secs, m_1 kg of

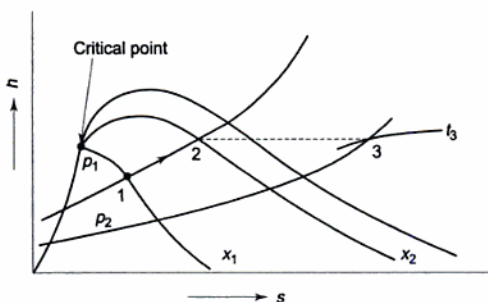

Fig. 9.27 Separating and throttling processes on h-s plot

it is separated, and m_2 kg is throttled and then condensed to water and collected, then $m = m_1 + m_2$, and at state 2, the mass of dry vapour will be $x_2 m_2$. Therefore, the quality of the sample of steam at state 1, x_1 is given by

$$x_1 = \frac{\text{mass of dry vapour at state 1}}{\text{mass of liquid-vapour mixture at state 1}}$$

$$= \frac{x_2 m_2}{m_1 + m_2}$$

The quality of wet steam can also be measured by an *electric calorimeter* (Fig. 9.28). The sample of steam is passed in steady flow through an electric heater, as shown. The electrical energy input Q should be sufficient to take the steam to the superheated region where pressure p_2 and temperature t_2 are measured. If I is the current flowing through the heater in amperes and V is the voltage across the coil, then at steady state $Q = VI \times 10^{-3}$ kW. If m is the mass of steam taken in t seconds under steady flow condition, then the steady flow energy equation for the heater (as control volume) gives

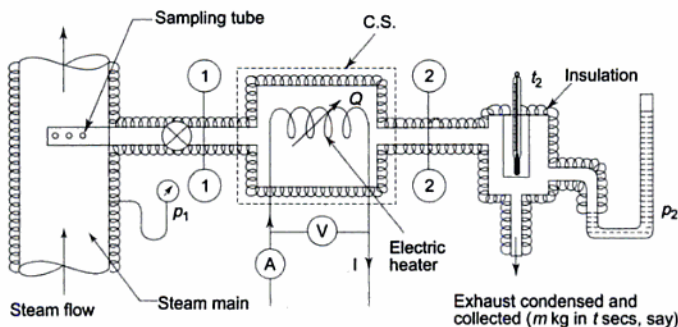

Fig. 9.28 Electrical calorimeter

$$w_1 h_1 + Q = w_1 h_2$$

where w_1 is the steam flow rate in kg/s ($w_1 = \frac{m}{t}$ kg/s)

$$\therefore h_1 + \frac{Q}{w_1} = h_2$$

With h_2 , Q and w_1 being known, h_1 can be computed. Now

$$h_1 = h_{fp1} + x_1 h_{fgp1}$$

Hence x_1 can be evaluated.

SOLVED EXAMPLES

Example 9.1 Find the saturation temperature, the changes in specific volume and entropy during evaporation, and the latent heat of vaporization of steam at 1 MPa.

Solution At 1 MPa, from Table A.1(b) in the Appendix

$$t_{\text{sat}} = 179.91^\circ\text{C}$$

$$v_f = 0.001127 \text{ m}^3/\text{kg} \quad \text{Ans.}$$

$$v_g = 0.19444 \text{ m}^3/\text{kg}$$

$$\therefore v_{fg} = v_g - v_f = 0.1933 \text{ m}^3/\text{kg}$$

$$s_f = 2.1387 \text{ kJ/kg K}$$

$$s_g = 6.5865 \text{ kJ/kg K}$$

$$\therefore s_{fg} = s_g - s_f = 4.4478 \text{ kJ/kg K} \quad \text{Ans.}$$

$$h_{fg} = h_g - h_f = 2015.3 \text{ kJ/kg} \quad \text{Ans.}$$

Example 9.2 Saturated steam has an entropy of 6.76 kJ/kg K. What are its pressure, temperature, specific volume, and enthalpy?

Solution In Table A.1(b), when $s_g = 6.76$ kJ/kg K

$$p = 0.6 \text{ MPa}, \quad t = 158.85^\circ\text{C}$$

$$v_g = 0.3156 \text{ m}^3/\text{kg}, \text{ and } h_g = 2756.8 \text{ kJ/kg} \quad \text{Ans.}$$

Example 9.3 Find the enthalpy and entropy of steam when the pressure is 2 MPa and the specific volume is $0.09 \text{ m}^3/\text{kg}$.

Solution In Table A.1(b), when $p = 2$ MPa, $v_f = 0.001177 \text{ m}^3/\text{kg}$ and $v_g = 0.09963 \text{ m}^3/\text{kg}$. Since the given volume lies between v_f and v_g , the substance will be a mixture of liquid and vapour, and the state will be within the vapour dome. When in the two-phase region, the composition of the mixture or its quality has to be evaluated first. Now

$$v = v_f + x v_{fg}$$

$$0.09 = 0.001177 + x (0.09963 - 0.001177)$$

or $x = 0.904$ or 90.4%

At 2 MPa, $h_f = 908.79$ and $h_{fg} = 1890.7$ kJ/kg
 $s_f = 2.4474$ and $s_{fg} = 3.8935$ kJ/kg K
 $h = h_f + x h_{fg}$
 $= 908.79 + 0.904 \times 1890.7 = 2618.79$ kJ/kg *Ans.*
 $s = s_f + x s_{fg}$
 $= 2.4474 + 0.904 \times 3.8935$
 $= 5.9534$ kJ/kg K *Ans.*

Example 9.4 Find the enthalpy, entropy, and volume of steam at 1.4 MPa, 380°C.

Solution At $p = 1.4$ MPa, in Table A.1(b), $t_{\text{sat}} = 195.07^\circ\text{C}$. Therefore, the state of steam must be in the superheated region. In Table A.2, for properties of superheated steam,

at 1.4 MPa, 350°C $v = 0.2003$ m³/kg
 $h = 3149.5$ kJ/kg
 $s = 7.1360$ kJ/kg K
 and at 1.4 MPa, 400°C $v = 0.2178$ m³/kg
 $h = 3257.5$ kJ/kg
 $s = 7.3026$ kJ/kg K

∴ By interpolation

at 1.4 MPa, 380°C $v = 0.2108$ m³/kg
 $h = 3214.3$ kJ/kg
 $s = 7.2360$ kJ/kg K *Ans.*

Example 9.5 A vessel of volume 0.04 m³ contains a mixture of saturated water and saturated steam at a temperature of 250°C. The mass of the liquid present is 9 kg. Find the pressure, the mass, the specific volume, the enthalpy, the entropy, and the internal energy.

Solution From Table A.1(a), at 250°C $p_{\text{sat}} = 3.973$ MPa
 $v_f = 0.0012512$ m³/kg, $v_g = 0.05013$ m³/kg
 $h_f = 1085.36$ kJ/kg, $h_{fg} = 1716.2$ kJ/kg
 $s_f = 2.7927$ kJ/kg K, $s_{fg} = 3.2802$ kJ/kg K

Volume of liquid, $V_f = m_f v_f$
 $= 9 \times 0.0012512$
 $= 0.01126$ m³

Volume of vapour, $V_g = 0.04 - 0.01126$
 $= 0.02874$ m³

∴ Mass of vapour

$$m_g = \frac{V_g}{v_g} = \frac{0.02874}{0.05013} = 0.575 \text{ kg}$$

∴ Total mass of mixture,

$$m = m_f + m_g = 9 + 0.575 = 9.575 \text{ kg} \quad \text{Ans.}$$

Quality of mixture,

$$x = \frac{m_g}{m_f + m_g} = \frac{0.575}{9.575} = 0.06$$

∴

$$\begin{aligned} v &= v_f + xv_{fg} \\ &= 0.0012512 + 0.06(0.05013 - 0.0012512) \\ &= 0.00418 \text{ m}^3/\text{kg} \quad \text{Ans.} \end{aligned}$$

$$\begin{aligned} h &= h_f + xh_{fg} \\ &= 1085.36 + 0.06 \times 1716.2 \\ &= 1188.32 \text{ kJ/kg} \quad \text{Ans.} \end{aligned}$$

$$\begin{aligned} s &= s_f + xs_{fg} \\ &= 2.7927 + 0.06 \times 3.2802 \\ &= 2.9895 \text{ kJ/kg K} \quad \text{Ans.} \end{aligned}$$

$$\begin{aligned} u &= h - pv \\ &= 1188.32 - 3.973 \times 10^3 \times 0.00418 \\ &= 1171.72 \text{ kJ/kg} \quad \text{Ans.} \end{aligned}$$

Also, at 250°C,

$$u_f = 1080.39 \text{ and } u_{fg} = 1522.0 \text{ kJ/kg}$$

∴

$$\begin{aligned} u &= u_f + xu_{fg} \\ &= 1080.39 + 0.06 \times 1522 \\ &= 1071.71 \text{ kJ/kg} \quad \text{Ans.} \end{aligned}$$

Example 9.6 Steam initially at 0.3 MPa, 250°C is cooled at constant volume. (a) At what temperature will the steam become saturated vapour? (b) What is the quality at 80°C? What is the heat transferred per kg of steam in cooling from 250°C to 80°C?

Solution At 0.3 MPa, $t_{\text{sat}} = 133.55^\circ\text{C}$

Since $t > t_{\text{sat}}$, the state would be in the superheated region (Fig. Ex. 9.6). From Table A.2, for properties of superheated steam, at 0.3 MPa, 250°C

$$v = 0.7964 \text{ m}^3/\text{kg}$$

$$h = 2967.6 \text{ kJ/kg}$$

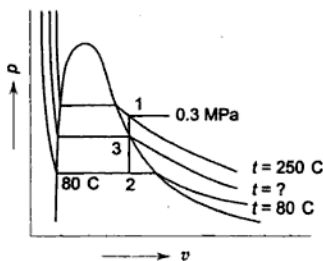

Fig. Ex. 9.6

$$\therefore v_1 = v_3 = v_2 = 0.7964 \text{ m}^3/\text{kg}$$

In Table A.1

when $v_g = 0.8919, t_{\text{sat}} = 120^\circ\text{C}$

when $v_g = 0.7706, t_{\text{sat}} = 125^\circ\text{C}$

Therefore, when $v_g = 0.7964, t_{\text{sat}}$, by linear interpolation, would be 123.9° .

Steam would become saturated vapour at $t = 123.9^\circ\text{C}$ Ans. (a)

At 80°C , $v_f = 0.001029 \text{ m}^3/\text{kg}$, $v_g = 3.407 \text{ m}^3/\text{kg}$,

$$h_f = 334.91 \text{ kJ/kg}, h_{fg} = 2308.8 \text{ kJ/kg}, p_{\text{sat}} = 47.39 \text{ kPa}$$

$$\begin{aligned} v_1 = v_2 = 0.7964 \text{ m}^3/\text{kg} &= v_{f80^\circ\text{C}} + x_2 v_{fg80^\circ\text{C}} \\ &= 0.001029 + x_2 (3.407 - 0.001029) \end{aligned}$$

$$\therefore x_2 = \frac{0.79539}{3.40597} = 0.234 \quad \text{Ans. (b)}$$

$$h_2 = 334.91 + 0.234 \times 2308.8 = 875.9 \text{ kJ/kg}$$

$$h_2 = 2967.6 \text{ kJ/kg}$$

From the first law of thermodynamics

$$\delta Q = du + pdv$$

$$\therefore (\delta Q)_v = du$$

$$\begin{aligned} \text{or } Q_{1-2} = u_2 - u_1 &= (h_2 - p_2 v_2) - (h_1 - p_1 v_1) \\ &= (h_2 - h_1) + v(p_1 - p_2) \\ &= 875.9 - 2967.6 + 0.7964 (300 - 47.39) \\ &= 2091.7 + 201.5 \\ &= -1890.2 \text{ kJ/kg} \end{aligned} \quad \text{Ans. (c)}$$

Example 9.7 Steam initially at 1.5 MPa, 300°C expands reversibly and adiabatically in a steam turbine to 40°C . Determine the ideal work output of the turbine per kg of steam.

Solution The steady flow energy equation for the control volume, as shown in Fig. Ex. 9.7.1, gives (other energy terms being neglected)

$$h_1 = h_2 + W$$

$$\therefore W = h_1 - h_2$$

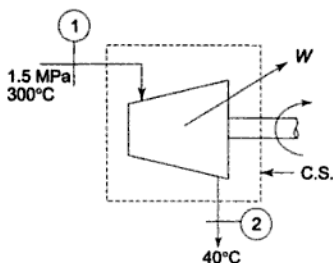

Fig. Ex. 9.7.1

Work is done by steam at the expense of a fall in its enthalpy value. The process is reversible and adiabatic, so it is isentropic. The process is shown on the T - s and h - s diagrams in Fig. Ex. 9.7.2.

From Table A.1(a), at 40°C

$$p_{\text{sat}} = 7.384 \text{ kPa}, s_f = 0.5725, \text{ and } s_{fg} = 7.6845 \text{ kJ/kg K}$$

$$h_f = 167.57, \text{ and } h_{fg} = 2406.7 \text{ kJ/kg}$$

At $p = 1.5 \text{ MPa}, t = 300^\circ\text{C}$, from the tabulated properties of superheated steam (Table A.2)

$$s_1 = 6.9189 \text{ kJ/kg K}$$

$$h_1 = 3037.6 \text{ kJ/kg}$$

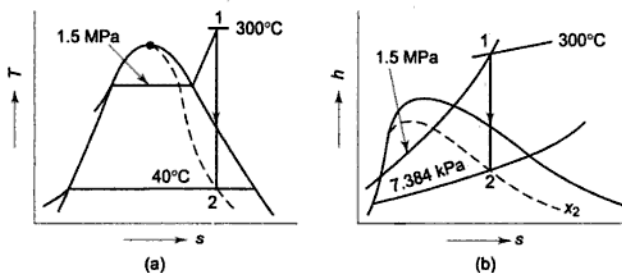

Fig. Ex. 9.7.2

Since

$$s_1 = s_2$$

$$6.9189 = s_f + x_2 s_{fg, 40^\circ\text{C}}$$

$$= 0.5725 + x_2 \times 7.6845$$

$$x_2 = \frac{6.3464}{7.6845} = 0.826 \text{ or } 82.6\%$$

\therefore

$$h_2 = h_{f, 40^\circ\text{C}} + x_2 h_{fg, 40^\circ\text{C}}$$

$$= 167.57 + 0.826 \times 2406.7$$

$$= 2152.57 \text{ kJ/kg}$$

\therefore

$$W = h_1 - h_2 = 3037.6 - 2152.57$$

$$= 885.03 \text{ kJ/kg}$$

Ans.

Example 9.8 Steam at $0.8 \text{ MPa}, 250^\circ\text{C}$ and flowing at the rate of 1 kg/s passes into a pipe carrying wet steam at $0.8 \text{ MPa}, 0.95$ dry. After adiabatic mixing the flow rate is 2.3 kg/s . Determine the condition of steam after mixing.

The mixture is now expanded in a frictionless nozzle isentropically to a pressure of 0.4 MPa . Determine the velocity of the steam leaving the nozzle. Neglect the velocity of steam in the pipeline.

Solution Figure Ex. 9.8.1 gives the flow diagram.

$$w_2 = w_3 - w_1 = 2.3 - 1.0 = 1.3 \text{ kg/s}$$

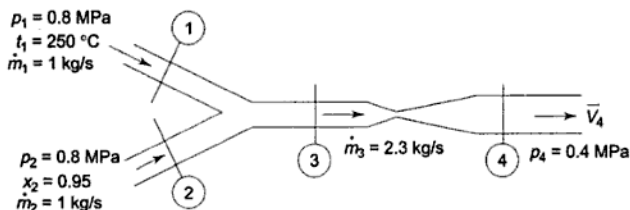

Fig. Ex. 9.8.1

The energy equation for the adiabatic mixing of the two streams gives

$$w_1 h_1 + w_2 h_2 = w_3 h_3 \quad (9.8.1)$$

At 0.8 MPa, 250°C, $h_1 = 2950.0$ kJ/kg

At 0.8 MPa, 0.95 dry

$$\begin{aligned} h_2 &= h_f + 0.95 h_{fg} \\ &= 721.11 + 0.95 \times 2048.0 \\ &= 2666.71 \text{ kJ/kg} \end{aligned}$$

∴ From Eq. (9.8.1)

$$1 \times 2950 + 1.3 \times 2666.71 = 2.3 \times h_3$$

∴ $h_3 = 2790$ kJ/kg

Since $(h_g)_{0.8 \text{ MPa}} = 2769.1$ kJ/kg

and $h_3 > h_g$, the state must be in the superheated region. From the steam tables, when $p = 0.8$ MPa, $t = 200^\circ\text{C}$

$$h = 2839.3 \text{ kJ/kg}$$

When

$$p = 0.8 \text{ MPa}, t_{\text{sat}} = 170.43^\circ\text{C}$$

$$h_g = 2769.1 \text{ kJ/kg}$$

By linear interpolation

$$t_3 = 179^\circ\text{C}$$

∴ Degree of superheat = $179 - 170.33 = 8.57^\circ\text{C}$

∴ Condition of steam after mixing = 0.8 MPa, 179°C

Ans.

The energy equation for the nozzle gives

$$h_3 = h_4 + \frac{V_4^2}{2}$$

since $V_3 = -$ velocity of steam in the pipeline = 0

Steam expands isentropically in the nozzle to 0.4 MPa. By interpolation,

$$s_3 = 6.7087 \text{ kJ/kg K} = s_4$$

∴ $6.7087 = 1.7766 + x_4 \times 5.1193$

$$x_4 = 0.964$$

∴ $h_4 = 604.74 + 0.964 \times 2133.8 = 2660$ kJ/kg

$$V_4^2 \times 10^{-3} = 2(h_3 - h_4) = 2 \times 130 = 260$$

$$V_4 = \sqrt{26} \times 100 = 509.9 \text{ m/s}$$

Ans.

The processes are shown on the h - s and T - s diagrams in Fig. Ex. 9.8.2.

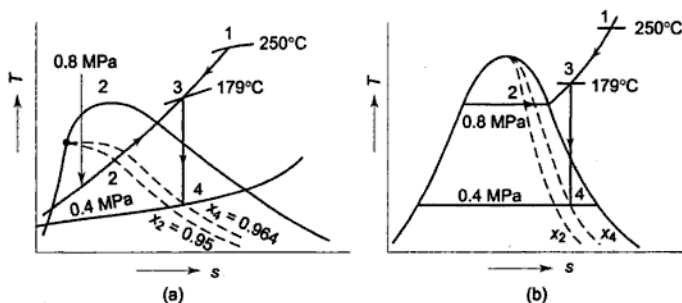

Fig. Ex. 9.8.2

Example 9.9 Steam flows in a pipeline at 1.5 MPa. After expanding to 0.1 MPa in a throttling calorimeter, the temperature is found to be 120°C. Find the quality of steam in the pipeline. What is the maximum moisture at 1.5 MPa that can be determined with this set-up if at least 5°C of superheat is required after throttling for accurate readings?

Solution At state 2 (Fig. Ex. 9.9), when $p = 0.1$ MPa, $t = 120^\circ\text{C}$ by interpolation

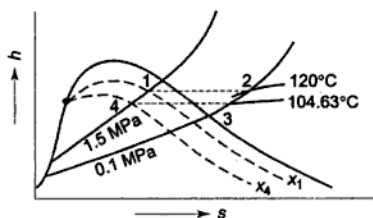

Fig. Ex. 9.9

$$h_2 = 2716.2 \text{ kJ/kg, and at } p = 1.5 \text{ MPa}$$

$$h_f = 844.89 \text{ and } h_{fg} = 1947.3 \text{ kJ/kg}$$

$$h_1 = h_2$$

$$h_{f1.5\text{MPa}} + x_1 h_{fg1.5\text{MPa}} = h_2$$

$$844.89 + x_1 \times 1947.3 = 2716.2$$

$$x_1 = \frac{1871.3}{1947.3} = 0.963$$

Ans.

When $p = 0.1$ MPa and $t = 99.63 + 5 = 104.63^\circ\text{C}$

Since $h_3 = 2685.5 \text{ kJ/kg}$
 $h_3 = h_4$
 $2685.5 = 844.89 + x_4 \times 1947.3$

$\therefore x_4 = \frac{1840.6}{1947.3} = 0.948$

The maximum moisture that can be determined with this set-up is only 5.2%.

Ans.

Example 9.10 The following data were obtained with a separating and throttling calorimeter:

Pressure in pipeline	1.5 MPa
Condition after throttling	0.1 MPa, 110°C
During 5 min moisture collected in the separator	0.150 litre at 70°C
Steam condensed after throttling during 5 min	3.24 kg
Find the quality of steam in the pipeline	

Solution As shown in Fig. Ex. 9.10,

at 0.1 MPa, 110°C $h_3 = 2696.2 \text{ kJ/kg}$

Now $h_3 = h_2 = h_{f1.5\text{MPa}} + x_2 h_{fg1.5\text{MPa}}$

or $2696.2 = 844.89 + x_2 \times 1947.3$

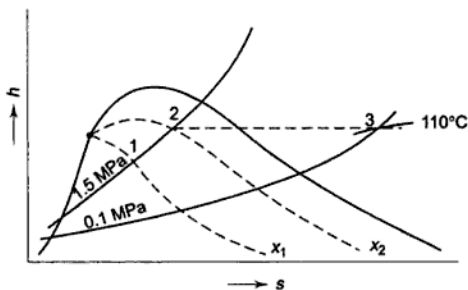

Fig. Ex. 9.10

$\therefore x_2 = \frac{1851.31}{1947.3} = 0.955$

If m_1 = mass of moisture collected in separator in 5 min and m_2 = mass of steam condensed after throttling in 5 min.

then $x_1 = \frac{x_2 m_2}{m_1 + m_2}$

At 70°C, $v_f = 0.001023 \text{ m}^3/\text{kg}$

$$m_1 = \frac{150 \times 10^{-6} \text{ m}^3}{1023 \times 10^{-6} \text{ m}^3/\text{kg}}$$

$$= 0.1462 \text{ kg}$$

$$m_2 = 3.24 \text{ kg}$$

$$\therefore x_1 = \frac{0.955 \times 3.24}{0.1462 + 3.24} = \frac{3.1}{3.3862} = 0.915 \quad \text{Ans.}$$

Example 9.11 A steam boiler initially contains 5 m^3 of steam and 5 m^3 of water at 1 MPa. Steam is taken out at constant pressure until 4 m^3 of water is left. What is the heat transferred during the process?

Solution At 1 MPa,

$$v_f = 0.001127, \text{ and } v_g = 0.1944 \text{ m}^3/\text{kg}$$

$$h_g = 2778.1 \text{ kJ/kg}$$

$$u_f = 761.68, u_g = 2583.6 \text{ kJ/kg}$$

$$u_{fg} = 1822 \text{ kJ/kg}$$

The initial mass of saturated water and steam in the boiler (Fig. Ex. 9.11).

$$\frac{V_f}{v_f} + \frac{V_g}{v_g} = \frac{5}{0.001127} + \frac{5}{0.1944} = (4.45 \times 10^3 + 25.70) \text{ kg}$$

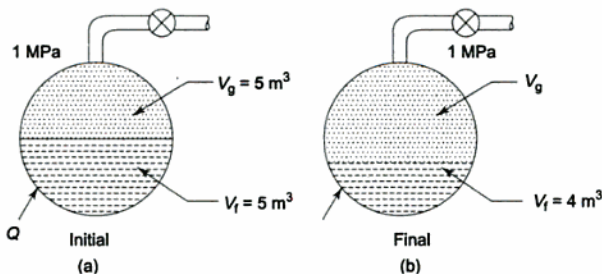

Fig. Ex. 9.11

where suffix f refers to saturated water and suffix g refers to saturated vapour. Final mass of saturated water and steam

$$= \frac{4}{0.001127} + \frac{6}{0.1944} = (3.55 \times 10^3 + 30.80) \text{ kg}$$

$$\begin{aligned} \therefore \text{Mass of steam taken out of the boiler } (m_s) & \\ &= (4.45 \times 10^3 + 25.70) - (3.55 \times 10^3 + 30.80) \\ &= 0.90 \times 10^3 - 5.1 = 894.9 \text{ kg} \end{aligned}$$

Making an energy balance, we have: Initial energy stored in saturated water and steam + Heat transferred from the external source = Final energy stored in saturated water and steam + Energy leaving with the steam.

$$\text{or } U_1 + Q = U_f + m_s h_g$$

assuming that the steam taken out is dry ($x = 1$)

$$\begin{aligned} \text{or } & 4.45 \times 10^3 \times 761.68 + 25.70 \times 2583.6 + Q \\ & = 3.55 \times 10^3 \times 761.68 + 30.8 \times 2583.6 + 894.9 \times 2778.1 \\ \text{or } & Q = 894.9 \times 2778.1 - (0.90 \times 10^3) \times 761.68 + 5.1 \times 2583.6 \\ & = 2425000 - 685500 + 13176 \\ & = 1752,676 \text{ kJ} = 1752.676 \text{ MJ} \end{aligned}$$

Ans.

Example 9.12 A 280 mm diameter cylinder fitted with a frictionless leakproof piston contains 0.02 kg of steam at a pressure of 0.6 MPa and a temperature of 200°C. As the piston moves slowly outwards through a distance of 305 mm, the steam undergoes a fully-resisted expansion during which the steam pressure p and the steam volume V are related by $pV^n = \text{constant}$, where n is a constant. The final pressure of the steam is 0.12 MPa. Determine (a) the value of n , (b) the work done by the steam, and (c) the magnitude and sign of heat transfer.

Solution Since the path of expansion (Fig. Ex. 9.12) follows the equation

$$\begin{aligned} pV^n &= C \\ p_1V_1^n &= p_2V_2^n \end{aligned}$$

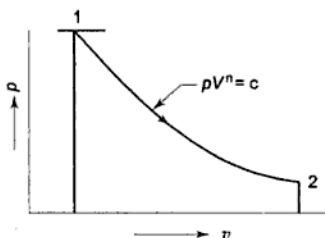

Fig. Ex. 9.12

Taking logarithms and arranging the terms

$$n = \frac{\log \frac{p_1}{p_2}}{\log \frac{V_2}{V_1}}$$

Now, at 0.7 MPa, 200°C, from Tables A.2

$$v_1 = 0.352 \text{ m}^3/\text{kg}$$

$$h_1 = 2850.1 \text{ kJ/kg}$$

$$\therefore \text{Total volume, } V_1, \text{ at state 1} = 0.352 \times 0.02 = 0.00704 \text{ m}^3$$

$$\text{Displaced volume} = \frac{\pi}{4} d^2 l$$

$$= \frac{\pi}{4} \times (0.28)^2 \times 0.305$$

$$= 0.0188 \text{ m}^3$$

∴ Total volume V_2 after expansion = $0.0188 + 0.00704 = 0.02584 \text{ m}^3$

$$n = \frac{\log \frac{0.6}{0.12}}{\log \frac{0.02584}{0.00704}} = \frac{\log 5}{\log 3.68} = 1.24 \quad \text{Ans. (a)}$$

Work done by steam in the expansion process

$$W_{1-2} = \int_{V_1}^{V_2} p dV = \frac{p_1 V_1 - p_2 V_2}{n - 1}$$

$$= \frac{6 \times 10^5 \text{ N/m}^2 \times 0.00704 \text{ m}^3 - 1.2 \times 10^5 \text{ N/m}^2 \times 0.02584 \text{ m}^3}{1.24 - 1}$$

$$= \frac{4224 - 3100.8}{0.24} \text{ N m}$$

$$= 4680 \text{ N m} = 4.68 \text{ kJ} \quad \text{Ans. (b)}$$

Now $V_2 = 0.02584 \text{ m}^3$

$$\therefore v_2 = \frac{0.02584}{0.02} = 1.292 \text{ m}^3/\text{kg}$$

Again $v_2 = v_{f0.12\text{MPa}} + x_2 v_{fg0.12\text{MPa}}$
 or $1.292 = 0.0010476 + x_2 \times 1.4271$

$$\therefore x_2 = \frac{1.291}{1.427} = 0.906$$

At 0.12 MPa, $u_f = 439.3 \text{ kJ/kg}$, $u_g = 2512.0 \text{ kJ/kg}$

$$\therefore u_2 = 439.3 + 0.906 (2512 - 439.3)$$

$$= 2314.3 \text{ kJ/kg}$$

Again $h_1 = 2850.1 \text{ kJ/kg}$

$$\therefore u_1 = h_1 - p_1 v_1 = 2850.1 - \frac{0.6 \times 10^6 \times 0.00704 \times 10^{-3}}{0.02}$$

$$= 2850.1 - 211.2 = 2638.9 \text{ kJ/kg}$$

By the first law

$$Q_{1-2} = U_2 - U_1 + W_{1-2}$$

$$= m(u_2 - u_1) + W_{1-2}$$

$$= 0.02 (2314.3 - 2638.5) + 4.68$$

$$= -6.484 + 4.68 = -1.804 \text{ kJ} \quad \text{Ans. (c)}$$

Example 9.13 A large insulated vessel is divided into two chambers, one containing 5 kg of dry saturated steam at 0.2 MPa and the other 10 kg of steam,

0.8 quality at 0.5 MPa. If the partition between the chambers is removed and the steam is mixed thoroughly and allowed to settle, find the final pressure, steam quality, and entropy change in the process.

Solution The vessel is divided into chambers, as shown in Fig. Ex. 9.13.1.

$$\begin{aligned} \text{At 0.2 MPa,} \quad v_g &= v_1 = 0.8857 \text{ m}^3/\text{kg} \\ \therefore V_1 &= m_1 v_1 = 5 \times 0.8857 \\ &= 4.4285 \text{ m}^3 \end{aligned}$$

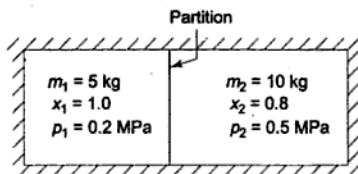

Fig. Ex. 9.13.1

$$\begin{aligned} \text{At 0.5 MPa,} \quad v_2 &= v_f + x_2 v_{fg} \\ &= 0.001093 + 0.8 \times 0.3749 \\ &= 0.30101 \text{ m}^3/\text{kg} \\ \therefore V_2 &= m_2 v_2 = 10 \times 0.30101 = 3.0101 \text{ m}^3 \\ \therefore \text{Total volume,} \quad V_m &= V_1 + V_2 = 7.4386 \text{ m}^3 \text{ (of mixture)} \end{aligned}$$

Total mass of mixture, $m_m = m_1 + m_2 = 5 + 10 = 15 \text{ kg}$

\therefore Specific volume of mixture

$$\begin{aligned} v_m &= \frac{V_m}{m_m} = \frac{7.4386}{15} \\ &= 0.496 \text{ m}^3/\text{kg} \end{aligned}$$

By energy balance

$$m_1 u_1 + m_2 u_2 = m_3 u_3$$

$$\begin{aligned} \text{At 0.2 MPa,} \quad h_g &= h_1 = 2706.7 \text{ kJ/kg} \\ u_1 &= h_1 - p_1 v_1 \cong 2706.7 \text{ kJ/kg} \end{aligned}$$

$$\begin{aligned} \text{At 0.5 MPa,} \quad h_2 &= h_f + x_2 h_{fg} \\ &= 640.23 + 0.8 \times 2108.5 \\ &= 2327.03 \text{ kJ/kg} \\ u_2 &= h_2 - p_2 v_2 \cong h_2 = 2327.03 \text{ kJ/kg} \\ h_3 &= h_m = \frac{5 \times 2706.7 + 10 \times 2327.03}{15} \end{aligned}$$

$$\therefore = 2453.6 \text{ kJ/kg} \cong u_3$$

Now for the mixture

$$h_3 = 2453.6 \text{ kJ/kg} = u_3$$

$$v_3 = 0.496 \text{ m}^3/\text{kg}$$

From the Mollier diagram, with the given values of h and v , point 3 after mixing is fixed (Fig. Ex. 9.13.2).

$$x_3 = 0.870$$

Ans.

$$s_3 = 6.29 \text{ kJ/kg K}$$

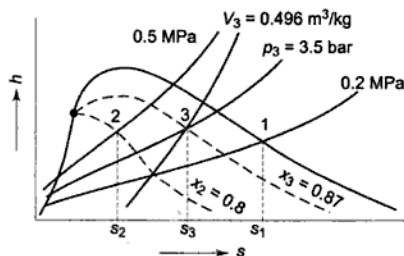

Fig. Ex. 9.13.2

$$p_3 = 3.5 \text{ bar}$$

Ans.

$$s_4 = s_{g0.2\text{MPa}} = 7.1271 \text{ kJ/kg K}$$

$$s_2 = s_{f0.5\text{MPa}} + 0.8s_{fg0.5\text{MPa}}$$

$$= 1.8607 + 0.8 \times 4.9606 = 5.8292 \text{ kJ/kg K}$$

Entropy change during the process

$$= m_3 s_3 - (m_1 s_1 + m_2 s_2)$$

$$= 15 \times 6.298 - (5 \times 7.1271 + 10 \times 5.8292)$$

$$= 0.43 \text{ kJ/kg}$$

Ans.

Example 9.14 Steam generated at a pressure of 6 MPa and a temperature of 400°C is supplied to a turbine via a throttle valve which reduces the pressure to 5 MPa. Expansion in the turbine is adiabatic to a pressure of 0.2 MPa, the isentropic efficiency (actual enthalpy drop/isentropic enthalpy drop) being 82%. The surroundings are at 0.1 MPa, 20°C. Determine the availability of steam before and after the throttle valve and at the turbine exhaust, and calculate the specific work output from the turbine. The K.E. and P.E. changes are negligible.

Solution Steady flow availability ψ is given by

$$\psi = (h - h_0) - T_0(s - s_0) + \frac{1}{2}V_1^2 + g(Z - Z_0)$$

where subscript 0 refers to the surroundings. Since the K.E. and P.E. changes are negligible

$$\psi_1 = \text{Availability of steam before throttling}$$

$$= (h_1 - h_0) - T_0(s_1 - s_0)$$

At 6 MPa, 400°C (Fig. Ex. 9.14)

$$h_1 = 3177.2 \text{ kJ/kg}$$

$$s_1 = 6.5408 \text{ kJ/kg K}$$

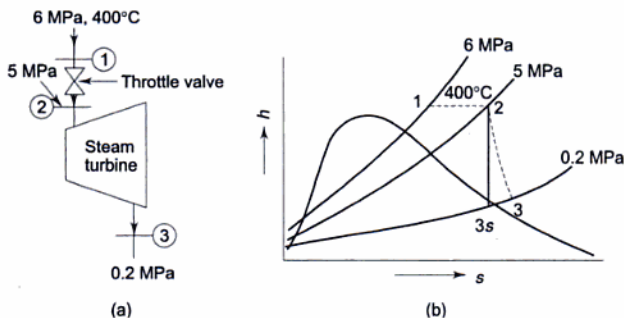

Fig. Ex. 9.14

At 20°C

$$h_0 = 83.96 \text{ kJ/kg}$$

$$s_0 = 0.2966 \text{ kJ/kg K}$$

$$\begin{aligned} \therefore \psi_1 &= (3177.2 - 83.96) - 293(6.5408 - 0.2966) \\ &= 3093.24 - 1829.54 = 1263.7 \text{ kJ/kg} \end{aligned}$$

Ans.

Now $h_1 = h_2$, for throttling

At $h = 3177.2 \text{ kJ/kg}$ and $p = 5 \text{ MPa}$, from the superheated steam table

$$\left. \begin{aligned} t_2 &= 390^\circ\text{C} \\ s_2 &= 6.63 \text{ kJ/kg K} \end{aligned} \right\} \text{ by linear interpolation}$$

$$\begin{aligned} \therefore \psi_2 &= \text{Availability of steam after throttling} \\ &= (h_2 - h_0) - T_0(s_2 - s_0) \\ &= (3177.2 - 83.96) - 293(6.63 - 0.2966) \\ &= 3093.24 - 1855.69 \\ &= 1237.55 \text{ kJ/kg} \end{aligned}$$

Decrease in availability due to throttling

$$= \psi_1 - \psi_2 = 1263.7 - 1237.55 = 26.15 \text{ kJ/kg}$$

Now

$$s_2 = s_{3s} = 6.63 = 1.5301 + x_{3s}(7.1271 - 1.5301)$$

$$\therefore x_{3s} = \frac{5.10}{5.5970} = 0.9112$$

$$h_{3s} = 504.7 + 0.9112 \times 2201.9 = 2511.07 \text{ kJ/kg}$$

$$h_2 - h_{3s} = 3177.2 - 2511.07 = 666.13 \text{ kJ/kg}$$

$$\therefore h_2 - h_3 = h_{is}(h_1 - h_{3s}) = 0.82 \times 666.13 = 546.2 \text{ kJ/kg}$$

$$\begin{aligned} \therefore h_3 &= 2631 \text{ kJ/kg} = 504.7 + x_2 \times 2201.7 \\ \therefore x_3 &= \frac{2126.3}{2201.7} = 0.966 \\ s_3 &= 1.5301 + 0.966 \times 5.597 = 6.9368 \\ \therefore \psi_3 &= \text{Availability of steam at turbine exhaust} \\ &= (h_3 - h_0) - T_0(s_3 - s_0) \\ &= (2631 - 83.96) - 293(6.9368 - 0.2966) \\ &= 2547.04 - 1945.58 \\ &= 601.46 \text{ kJ/kg} \end{aligned}$$

Specific work output from the turbine

$$= h_2 - h_3 = 3177.2 - 2631 = 546.2 \text{ kJ/kg} \quad \text{Ans.}$$

The work done is less than the loss of availability of steam between states 2 and 3, because of the irreversibility accounted for by the isentropic efficiency.

Example 9.15 A steam turbine receives 600 kg/h of steam at 25 bar, 350°C . At a certain stage of the turbine, steam at the rate of 150 kg/h is extracted at 3 bar, 200°C . The remaining steam leaves the turbine at 0.2 bar, 0.92 dry. During the expansion process, there is heat transfer from the turbine to the surroundings at the rate of 10 kJ/s. Evaluate per kg of steam entering the turbine (a) the availability of steam entering and leaving the turbine, (b) the maximum work, and (c) the irreversibility. The atmosphere is at 30°C .

Solution At 25 bar, 350°C

$$h_1 = 3125.87 \text{ kJ/kg}$$

$$s_1 = 6.8481 \text{ kJ/kg K}$$

At 30°C ,

$$h_0 = 125.79 \text{ kJ/kg}$$

$$s_0 = s_{30^\circ\text{C}} = 0.4369 \text{ kJ/kg K}$$

At 3 bar, 200°C

$$h_2 = 2865.5 \text{ kJ/kg}$$

$$s_2 = 7.3115 \text{ kJ/kg K}$$

At 0.2 bar (0.92 dry)

$$h_f = 251.4 \text{ kJ/kg}$$

$$h_{fg} = -2358.3 \text{ kJ/kg}$$

$$s_f = 0.8320 \text{ kJ/kg K}$$

$$s_g = 7.9085 \text{ kJ/kg K}$$

$$\therefore h_3 = 251.4 + 0.92 \times 2358.3 = 2421.04 \text{ kJ/kg}$$

$$s_3 = 0.8320 + 0.92 \times 7.0765 = 7.3424 \text{ kJ/kg K}$$

The states of steam are shown in Fig. Ex. 9.15.

(a) Availability of steam entering the turbine

$$\Psi_1 = (h_1 - h_0) - T_0(s_1 - s_0)$$

$$= (3125.87 - 125.79) - 303(6.8481 - 0.4369)$$

$$= 3000.08 - 1942.60 = 1057.48 \text{ kJ/kg} \quad \text{Ans.}$$

Availability of steam leaving the turbine at state 2,

$$\Psi_2 = (h_2 - h_0) - T_0(s_2 - s_0)$$

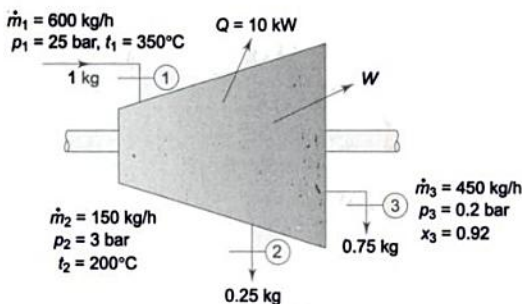

Fig. Ex. 9.15

$$\begin{aligned}
 &= (2865.5 - 125.79) - 303 (7.3115 - 0.4369) \\
 &= 2739.71 - 2083.00 = 656.71 \text{ kJ/kg}
 \end{aligned}$$

Availability of steam leaving the turbine at state 3,

$$\begin{aligned}
 \Psi_3 &= (h_3 - h_0) - T_0 (s_3 - s_0) = (2421.04 - 125.79) - 303 (7.3524 - 0.4369) \\
 &= 199.85 \text{ kJ/kg}
 \end{aligned}$$

(b) Maximum work per kg of steam entering the turbine

$$\begin{aligned}
 W_{\text{rev}} &= \Psi_1 - \frac{m_2}{m_1} \Psi_2 - \frac{m_3}{m_1} \Psi_3 = 1057.48 - 0.25 \times 656.71 - 0.75 \times 199.85 \\
 &= 743.41 \text{ kJ/kg}
 \end{aligned}$$

Ans.

(c) Irreversibility

$$\begin{aligned}
 I &= T_0 (w_2 s_2 + w_3 s_3 - w_1 s_1) - Q \\
 &= 303 (150 \times 7.3115 + 450 \times 7.3424 - 600 \times 6.8481) - (-10 \times 3600) \\
 &= 303 (1096.73 + 3304.08 - 4108.86) = 36000 \\
 &= 124,460.85 \text{ kJ/h} \\
 &= 124.461 \text{ MJ/h} = \frac{124.461 \times 103}{600} = 207.44 \text{ kJ/kg}
 \end{aligned}$$

Ans.

Example 9.16 Determine the exergy of (a) 3 kg of water at 1 bar and 90°C, (b) 0.2 kg of steam at 4 MPa, 500°C and (c) 0.4 kg of wet steam at 0.1 bar and 0.85 quality, (d) 3 kg of ice at 1 bar - 10°C. Assume a dead state of 1 bar and 300 K.

Solution At the dead state of 1 bar, 300 K,

$$u_0 = 113.1 \text{ kJ/kg}, h_0 = 113.2 \text{ kJ/kg K.}$$

$$v_0 = 0.001005 \text{ m}^3/\text{kg}, s_0 = 0.395 \text{ kJ/kg}$$

Exergy of the system:

$$\phi = m[(u + p_0 v - T_0 s) - (u_0 + p_0 v_0 - T_0 s_0)]$$

$$\begin{aligned}
 \text{Now, } u_0 + p_0 v_0 - T_0 s_0 &= h_0 - T_0 s_0 \\
 &= 113.2 - 300 \times 0.395 \\
 &= -5.3 \text{ kJ/kg}
 \end{aligned}$$

(a) For water at 1 bar, 90°C

$$u = 376.9 \text{ kJ/kg}, h = 377 \text{ kJ/kg}, v = 0.001035 \text{ m}^3/\text{kg}$$

$$s = 1.193 \text{ kJ/kg K.}$$

Since

$$P = p_0,$$

$$u + p_0v - T_0s = u + pv - T_0s = h - T_0s$$

$$= 377 - 300 \times 1.193$$

$$= 19.1 \text{ kJ/kg}$$

Hence,

$$\phi = 3[19.1 - (-5.3)] = 3 \times 24.4$$

$$= 73.2 \text{ kJ}$$

Ans.

(b) At $p = 4 \text{ MPa}$, $t = 500^\circ\text{C}$

$$u = 3099.8, h = 3446.3 \text{ kJ/kg}, v = 0.08637 \text{ m}^3/\text{kg}$$

$$s = 7.090 \text{ kJ/kgK}$$

$$u + p_0v - T_0s = 3099.8 + 100 \times 0.08637 - 300 \times 7.090$$

$$= 981.4 \text{ kJ/kg}$$

$$\phi = 0.2 [981.4 - (-5.3)] = 197.34 \text{ kJ}$$

Ans.

(c) At 0.1 bar, 0.85 quality,

$$u = 192 + 0.85 \times 2245 = 2100.25 \text{ kJ/kg}$$

$$h = 192 + 0.85 \times 2392 = 2225.2 \text{ kJ/kg}$$

$$s = 0.649 + 0.85 \times 7.499 = 7.023 \text{ kJ/kg K}$$

$$v = 0.001010 + 0.85 \times 14.67 = 12.47 \text{ m}^3/\text{kg}$$

$$u + p_0v - T_0s = 2100.25 + 100 \times 12.47 - 300 \times 7.023$$

$$= 1240.4 \text{ kJ/kg}$$

$$\phi = 0.4 [1240.4 - (-5.3)] = 498.3 \text{ kJ}$$

Ans.

(d) Since $p = p_0$,

$$\phi = U - U_0 + p_0(V - V_0) - T_0(S - S_0)$$

$$= H - H_0 - V(p - p_0) - T_0(S - S_0)$$

$$= m[(h - h_0) - T_0(s - s_0)]$$

At 100 kPa, -10°C ,

$$h = -354.1 \text{ kJ/kg and } s = -1.298 \text{ kJ/kg K}$$

$$\phi = 3[-354.1 - 113.2 - 300(-1.298 - 0.0395)]$$

$$= 81.2 \text{ kJ.}$$

Ans.

Example 9.17 A flow of hot water at 90°C is used to heat relatively cold water at 25°C to a temperature of 50°C in a heat exchanger. The cold water flows at the rate of 1 kg/s. When the heat exchanger is operated in the parallel mode, the exit temperature of the hot water stream must not be less than 60°C . In the counterflow operation, the exit temperature of hot water can be as low as 35°C . Compare the second law efficiency and the rate of exergy destruction in the two modes of operation. Take $T_0 = 300 \text{ K}$.

Solution Given: $t_{h1} = 90^\circ\text{C}$, $t_{c1} = 25^\circ\text{C}$, $t_{c2} = 60^\circ\text{C}$,

$$\dot{m}_c = 1 \text{ kg/s}, T_0 = 300 \text{ K.}$$

The two modes of operation of (a) parallel flow and (b) counterflow are shown in Fig. Ex. 9.17.

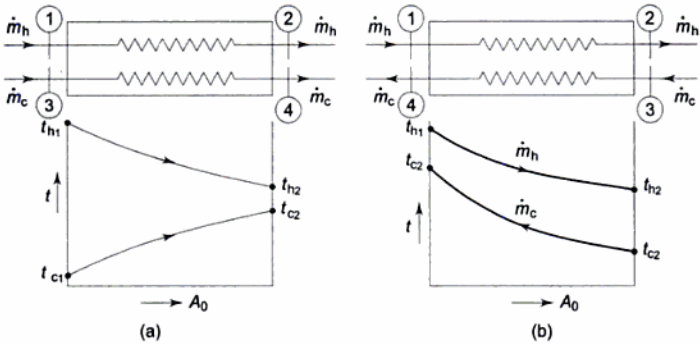

Fig. Ex. 9.17

In parallel flow mode (a), $t_{h2} = 60^\circ\text{C}$. Neglecting any heat loss,

$$\dot{m}_h c_h (t_{h1} - t_{h2}) = \dot{m}_c c_c (t_{c2} - t_{c1})$$

$$\dot{m}_h (90 - 60) = 1(50 - 25)$$

$$\dot{m}_h = 0.833 \text{ kg/s}$$

In counterflow mode, $t_{h2} = 35^\circ\text{C}$,

$$\dot{m}_h (90 - 35) = 1(50 - 25)$$

$$\dot{m}_h = \frac{25}{55} = 0.454 \text{ kg/s}$$

Thus, the counterflow arrangement uses significantly less hot water.

Assuming that the hot water stream on exit from the heat exchanger is simply dumped into the drain, the exergy flow rate of the hot water stream at entry is considered as the exergy input rate to the process.

$$a_{f1} = \dot{m}_h [(h_1 - h_0) - T_0(s_1 - s_0)]$$

At 300 K or 27°C , $h_0 = 113.2 \text{ kJ/kg}$ and $s_0 = 0.395 \text{ kJ/kg K}$

At 90°C , $h_1 = 376.92 \text{ kJ/kg}$, $s_1 = 1.1925 \text{ kJ/kg K}$

$$\begin{aligned} a_{f1} &= 0.833 [(376.92 - 113.2) - 300(1.1925 - 0.395)] \\ &= 0.833 (263.72 - 239.25) = 20.38 \text{ kW} \end{aligned}$$

Parallel flow:

At 60°C , $h_2 = 251.13 \text{ kJ/kg}$, $s_2 = 0.8312 \text{ kJ/kg K}$

At 25°C , $h_3 = 104.89 \text{ kJ/kg}$, $s_3 = 0.3674 \text{ kJ/kg K}$

At 50°C , $h_4 = 209.33 \text{ kJ/kg}$, $s_4 = 0.7038 \text{ kJ/kg K}$

Rate of exergy gain:

$$= \dot{m}_c [(h_4 - h_3) - T_0(s_4 - s_3)]$$

$$= 1[(209.33 - 104.89) - 300(0.7038 - 0.3674)]$$

$$= 104.44 - 100.92 = 3.52 \text{ kW}$$

$$(\eta_{II})_P = \frac{3.52}{20.38} = 0.172 \text{ or } 17.2\%$$

Rate of exergy loss by hot water:

$$= \dot{m}_h [(h_1 - h_2) - T_0(s_1 - s_2)]$$

$$= 0.833 [(376.92 - 251.13) - 300(1.1925 - 0.8312)]$$

$$= 0.833 (125.79 - 108.39) = 14.494 \text{ kW}$$

Rate of irreversibility or exergy destruction:

$$= 14.494 - 3.52 = 10.974 \text{ kW}$$

If the hot water stream is not dumped to the drain,

$$\eta_{II,P} = \frac{3.52}{14.494} = 0.243 \text{ or } 24.3\% \quad \text{Ans.}$$

Counterflow:

At 35°C, $h_2 = 146.68 \text{ kJ/kg}$, $s_2 = 0.5053 \text{ kJ/kg K}$

$$\text{Rate of exergy gain of cold water} = \dot{m}_h [(h_4 - h_3) - T_0(s_4 - s_3)] = 3.52 \text{ kW}$$

(same as in parallel flow)

Rate of exergy input (if exiting hot water is dumped to the surroundings)

$$= 0.454 (263.72 - 239.25) = 11.11 \text{ kW}$$

$$\eta_{II,C} = \frac{3.52}{11.11} = 0.3168 \text{ or } 31.68\%$$

Rate of exergy loss of hot water:

$$= \dot{m}_h [(h_1 - h_2) - T_0(s_1 - s_2)]$$

$$= 0.454 [(376.92 - 146.68) - 300(1.1925 - 0.5053)]$$

$$= 0.454 (230.24 - 206.16) = 10.94 \text{ kW}$$

$$\eta_{II,C} = \frac{3.52}{10.94} = 0.3217 \text{ or } 32.17\% \quad \text{Ans.}$$

Rate of irreversibility or exergy destruction:

$$= 10.94 - 3.52 = 7.42 \text{ kW} \quad \text{Ans.}$$

The second law efficiency for the counterflow arrangement is significantly higher and the rate of irreversibility is substantially lower compared to the parallel flow arrangement.

Example 9.18 A small geothermal well in a remote desert area produces 50 kg/h of saturated steam vapour at 150°C. The environment temperature is 45°C. This geothermal steam will be suitably used to produce cooling for homes at 23°C. The steam will emerge from this system as saturated liquid at 1 atm. Estimate the maximum cooling rate that could be provided by such a system.

Solution The energy balance of the control volume as shown in Fig. Ex. 9.18 gives:

$$\dot{Q} + wh_1 = \dot{Q}_0 + wh_2$$

The entropy balance is:

$$\dot{S}_{\text{gen}} = \left[\frac{\dot{Q}_0}{T_0} + ws_2 \right] - \left[\frac{\dot{Q}}{T} + ws_1 \right]$$

where T is the temperature maintained in the homes.

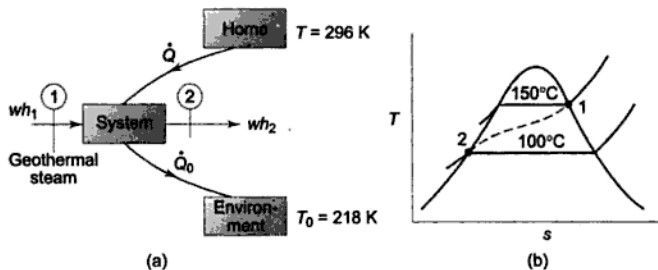

Fig. Ex. 9.18

Solving for \dot{Q} ,

$$\dot{Q} = \frac{w[(h_1 - T_0s_1) - (h_2 - T_0s_2)] - T_0\dot{S}_{\text{gen}}}{(T_0/T) - 1}$$

By second law, $\dot{S}_{\text{gen}} > 0$.

Therefore, for a given discharge state 2, the maximum \dot{Q} would be

$$\dot{Q}_{\text{max}} = \frac{w(b_1 - b_2)}{(T_0/T) - 1}$$

State-1: $T_1 = 150^\circ\text{C} = 423 \text{ K}$, saturated vapour

$$h_1 = 2746.4 \text{ kJ/kg}$$

$$s_1 = 6.8387 \text{ kJ/kg K}$$

State-2: $T_2 = 100^\circ\text{C} = 373 \text{ K}$, saturated liquid

$$h_2 = 419.0 \text{ kJ/kg}$$

$$s_2 = 1.3071 \text{ kJ/kg K}$$

So, since

$$T_0 = 318 \text{ K},$$

$$b_1 = h_1 - T_0s_1 = 2746.4 - 318 \times 6.8387$$

$$= 571.7 \text{ kJ/kg}$$

$$b_2 = h_2 - T_0s_2 = 419.0 - 318 \times 1.3071 = 3.3 \text{ kJ/kg}$$

$$\dot{Q}_{\text{max}} = \frac{50 \times (571.7 - 3.3)}{(318/296) - 1} = 3.82 \times 10^5 \text{ kJ/h}$$

$$= 106 \text{ kW}$$

REVIEW QUESTIONS

- 9.1 What is a pure substance?
- 9.2 What are saturation states?
- 9.3 What do you understand by triple point?
Give the pressure and temperature of water at its triple point.
- 9.4 What is the critical state? Explain the terms critical pressure, critical temperature and critical volume of water?
- 9.5 What is normal boiling point.
- 9.6 Draw the phase equilibrium diagram on $p-v$ coordinates for a substance which shrinks in volume on melting and then for a substance which expands in volume on melting. Indicate thereon the relevant constant property lines.
- 9.7 Draw the phase equilibrium diagram for a pure substance on $p-T$ coordinates. Why does the fusion line for water have negative slope?
- 9.8 Draw the phase equilibrium diagram for a pure substance on $T-s$ plot with relevant constant property lines.
- 9.9 Draw the phase equilibrium diagram for a pure substance on $h-s$ plot with relevant constant property lines.
- 9.10 Why do the isobars on Mollier diagram diverge from one another?
- 9.11 Why do isotherms on Mollier diagram become horizontal in the superheated region at low pressures?
- 9.12 What do you understand by the degree of superheat and the degree of subcooling?
- 9.13 What is quality of steam? What are the different methods of measurement of quality?
- 9.14 Why cannot a throttling calorimeter measure the quality if the steam is very wet?
How is the quality measured then?
- 9.15 What is the principle of operation of an electrical calorimeter?

PROBLEMS

- 9.1 Complete the following table of properties for 1 kg of water (liquid, vapour or mixture).

	p (bar)	t (°C)	v (m ³ /kg)	x (%)	Super- heat (°C)	h (kJ/kg)	s (kJ/kg K)
(a)	—	35	25.22	—	—	—	—
(b)	—	—	0.001044	—	—	419.04	—
(c)	—	212.42	—	90	—	—	—
(d)	1	—	—	—	—	—	6.104
(e)	10	320	—	—	—	—	—
(f)	5	—	0.4646	—	—	—	—
(g)	4	—	0.4400	—	—	—	—
(h)	—	500	—	—	—	3445.3	—
(i)	20	—	—	—	50	—	—
(j)	15	—	—	—	—	—	7.2690

- 9.2 (a) A rigid vessel of volume 0.86 m^3 contains 1 kg of steam at a pressure of 2 bar. Evaluate the specific volume, temperature, dryness fraction, internal energy, enthalpy, and entropy of steam.
- (b) The steam is heated to raise its temperature to 150°C . Show the process on a sketch of the $p-v$ diagram, and evaluate the pressure, increase in enthalpy, increase in internal energy, increase in entropy of steam, and the heat transfer. Evaluate also the pressure at which the steam becomes dry saturated.

Ans. (a) $0.86 \text{ m}^3/\text{kg}$, 120.23°C , 0.97 , 2468.54 kJ/kg ,
 2640.54 kJ/kg , 6.9592 kJ/kg K

(b) 2.3 bar , 126 kJ/kg , 106.6 kJ/kg , 0.2598 kJ/kg K , 106.6 kJ/K

- 9.3 Ten kg of water at 45°C is heated at a constant pressure of 10 bar until it becomes superheated vapour at 300°C . Find the changes in volume, enthalpy, internal energy and entropy.

Ans. 2.569 m^3 , 28627.5 kJ , 26047.6 kJ , 64.842 kJ/K

- 9.4 Water at 40°C is continuously sprayed into a pipeline carrying 5 tonnes of steam at 5 bar, 300°C per hour. At a section downstream where the pressure is 3 bar, the quality is to be 95%. Find the rate of water spray in kg/h.

Ans. 912.67 kg/h

- 9.5 A rigid vessel contains 1 kg of a mixture of saturated water and saturated steam at a pressure of 0.15 MPa. When the mixture is heated, the state passes through the critical point. Determine (a) the volume of vessel (b) the mass of liquid and of vapour in the vessel initially, (c) the temperature of the mixture when the pressure has risen to 3 MPa, and (d) the heat transfer required to produce the final state (c).

Ans. (a) 0.003155 m^3 , (b) 0.9982 kg , 0.0018 kg ,
 (c) 233.9°C , (d) 581.46 kJ/kg

- 9.6 A rigid closed tank of volume 3 m^3 contains 5 kg of wet steam at a pressure of 200 kPa. The tank is heated until the steam becomes dry saturated. Determine the final pressure and the heat transfer to the tank.

Ans. 304 kPa , 3346 kJ

- 9.7 Steam flows through a small turbine at the rate of 5000 kg/h entering at 15 bar, 300°C and leaving at 0.1 bar with 4% moisture. The steam enters at 80 m/s at a point 3 m above the discharge and leaves at 40 m/s . Compute the shaft power assuming that the device is adiabatic but considering kinetic and potential energy changes. How much error would be made if these terms were neglected? Calculate the diameters of the inlet and discharge tubes.

Ans. 765.6 kW , 0.44% , 6.11 cm , 78.9 cm

- 9.8 A sample of steam from a boiler drum at 3 MPa is put through a throttling calorimeter in which the pressure and temperature are found to be 0.1 MPa, 120°C . Find the quality of the sample taken from the boiler.

Ans. 0.951

- 9.9 It is desired to measure the quality of wet steam at 0.5 MPa. The quality of steam is expected to be not more than 0.9.

- (a) Explain why a throttling calorimeter to atmospheric pressure will not serve the purpose.
- (b) Will the use of a separating calorimeter, ahead of the throttling calorimeter, serve the purpose, if at best 5 C degree of superheat is desirable at the end of

throttling? What is the minimum dryness fraction required at the exit of the separating calorimeter to satisfy this condition?

- 9.10 The following observations were recorded in an experiment with a combined separating and throttling calorimeter:

Pressure in the steam main — 15 bar

Mass of water drained from the separator — 0.55 kg

Mass of steam condensed after passing through the throttle valve — 4.20 kg

Pressure and temperature after throttling — 1 bar, 120°C

Evaluate the dryness fraction of the steam in the main, and state with reasons, whether the throttling calorimeter alone could have been used for this test.

Ans. 0.85

- 9.11 Steam from an engine exhaust at 1.25 bar flows steadily through an electric calorimeter and comes out at 1 bar, 130°C. The calorimeter has two 1 kW heaters and the flow is measured to be 3.4 kg in 5 min. Find the quality in the engine exhaust. For the same mass flow and pressures, what is the maximum moisture that can be determined if the outlet temperature is at least 105°C?

Ans. 0.944, 0.921

- 9.12 Steam expands isentropically in a nozzle from 1 MPa, 250°C to 10 kPa. The steam flow rate is 1 kg/s. Find the velocity of steam at the exit from the nozzle, and the exit area of the nozzle. Neglect the velocity of steam at the inlet to the nozzle.

The exhaust steam from the nozzle flows into a condenser and flows out as saturated water. The cooling water enters the condenser at 25°C and leaves at 35°C. Determine the mass flow rate of cooling water.

Ans. 1224 m/s, 0.0101 m², 47.81 kg/s

- 9.13 A reversible polytropic process, begins with steam at $p_1 = 10$ bar, $t_1 = 200^\circ\text{C}$, and ends with $p_2 = 1$ bar. The exponent n has the value 1.15. Find the final specific volume, the final temperature, and the heat transferred per kg of fluid.

- 9.14 Two streams of steam, one at 2 MPa, 300°C and the other at 2 MPa, 400°C, mix in a steady flow adiabatic process. The rates of flow of the two streams are 3 kg/min and 2 kg/min respectively. Evaluate the final temperature of the emerging stream, if there is no pressure drop due to the mixing process. What would be the rate of increase in the entropy of the universe? This stream with a negligible velocity now expands adiabatically in a nozzle to a pressure of 1 kPa. Determine the exit velocity of the stream and the exit area of the nozzle.

Ans. 340°C, 0.042 kJ/K min, 1530 m/s, 53.77 cm²

- 9.15 Boiler steam at 8 bar, 250°C, reaches the engine control valve through a pipeline at 7 bar, 200°C. It is throttled to 5 bar before expanding in the engine to 0.1 bar, 0.9 dry. Determine per kg of steam (a) the heat loss in the pipeline, (b) the temperature drop in passing through the throttle valve, (c) the work output of the engine, (d) the entropy change due to throttling and (e) the entropy change in passing through the engine.

Ans. (a) 105.3 kJ/kg, (b) 5°C, (c) 499.35 kJ/kg,
(d) 0.1433 kJ/kg K, (e) 0.3657 kJ/kg K

- 9.16 Tank *A* (Fig. P 9.16) has a volume of 0.1 m³ and contains steam at 200°C, 10% liquid and 90% vapour by volume, while tank *B* is evacuated. The valve is then opened, and the tanks eventually come to the same pressure, which is found to be

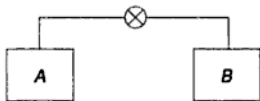

Fig. P 9.16

4 bar. During this process, heat is transferred such that the steam remains at 200°C . What is the volume of tank *B*?

Ans. 4.89 m^3

- 9.17 Calculate the amount of heat which enters or leaves 1 kg of steam initially at 0.5 MPa and 250°C , when it undergoes the following processes:
- It is confined by a piston in a cylinder and is compressed to 1 MPa and 300°C as the piston does 200 kJ of work on the steam.
 - It passes in steady flow through a device and leaves at 1 MPa and 300°C while, per kg of steam flowing through it, a shaft puts in 200 kJ of work. Changes in K.E. and P.E. are negligible.
 - It flows into an evacuated rigid container from a large source which is maintained at the initial condition of the steam. Then 200 kJ of shaft work is transferred to the steam, so that its final condition is 1 MPa and 300°C .

Ans. (a) - 130 kJ, (b) - 109 kJ, and (c) - 367 kJ

- 9.18 A sample of wet steam from a steam main flows steadily through a partially open valve into a pipeline in which is fitted an electric coil. The valve and the pipeline are well insulated. The steam mass flow rates 0.008 kg/s while the coil takes 3.91 amperes at 230 volts. The main pressure is 4 bar, and the pressure and temperature of the steam downstream of the coil are 2 bar and 160°C respectively. Steam velocities may be assumed to be negligible.
- Evaluate the quality of steam in the main.
 - State, with reasons, whether an insulated throttling calorimeter could be used for this test.

Ans. (a) 0.97, (b) not suitable

- 9.19 Two insulated tanks, *A* and *B*, are connected by a valve. Tank *A* has a volume of 0.70 m^3 and contains steam at 1.5 bar, 200°C . Tank *B* has a volume of 0.35 m^3 and contains steam at 6 bar with a quality of 90%. The valve is then opened, and the two tanks come to a uniform state. If there is no heat transfer during the process, what is the final pressure? Compute the entropy change of the universe.

Ans. 322.6 kPa, 0.1985 kJ/K

- 9.20 A spherical aluminium vessel has an inside diameter of 0.3 m and a 0.62 cm thick wall. The vessel contains water at 25°C with a quality of 1%. The vessel is then heated until the water inside is saturated vapour. Considering the vessel and water together as a system, calculate the heat transfer during this process. The density of aluminium is 2.7 g/cm^3 and its specific heat is 0.896 kJ/kg K .

Ans. 2682.82 kJ

- 9.21 Steam at 10 bar, 250°C flowing with negligible velocity at the rate of 3 kg/min mixes adiabatically with steam at 10 Bar, 0.75 quality, flowing also with negligible velocity at the rate of 5 kg/min. The combined stream of steam is throttled to 5 bar and then expanded isentropically in a nozzle to 2 bar. Determine (a) the state of steam after mixing, (b) the steam after throttling, (c) the increase

in entropy due to throttling, (d) the velocity of steam at the exit from the nozzle, and (e) the exit area of the nozzle. Neglect the K.E. of steam at the inlet to the nozzle.

Ans. (a) 10 bar, 0.975 dry, (b) 5 bar, 0.894 dry,
(c) 0.2669 kJ/kg K, (d) 540 m/s, (e) 1.864 cm²

- 9.22 Steam of 65 bar, 400°C leaves the boiler to enter a steam turbine fitted with a throttle governor. At a reduced load, as the governor takes action, the pressure of steam is reduced to 59 bar by throttling before it is admitted to the turbine. Evaluate the availabilities of steam before and after the throttling process and the irreversibility due to it.

- 9.23 A mass of wet steam at temperature 165°C is expanded at constant quality 0.8 to pressure 3 bar. It is then heated at constant pressure to a degree of superheat of 66.5°C. Find the enthalpy and entropy changes during expansion and during heating. Draw the T - s and h - s diagrams.

Ans. - 59 kJ/kg, 0.163 kJ/kg K during expansion and 676 kJ/kg,
1.588 kJ/kg K during heating

- 9.24 Steam enters a turbine at a pressure of 100 bar and a temperature of 400°C. At the exit of the turbine the pressure is 1 bar and the entropy is 0.6 J/g K greater than that at inlet. The process is adiabatic and changes in KE and PE may be neglected. Find the work done by the steam in J/g. What is the mass flow rate of steam required to produce a power output of 1 kW?

Ans. 625 J/g, 1.6 kg/s

- 9.25 One kg of steam in a closed system undergoes a thermodynamic cycle composed the following reversible processes: (1-2) The steam initially at 10 bar, 40% quality is heated at constant volume until the pressure rises to 35 bar; (2-3). It is then expanded isothermally to 10 bar; (3-1) It is finally cooled at constant pressure back to its initial state. Sketch the cycle on T - s coordinates, and calculate the work done, the heat transferred, and the change of entropy for each of the three processes. What is the thermal efficiency of the cycle?

Ans. 0; 1364 kJ; 2.781 kJ/K, 367.5 kJ; 404.6 kJ; 0.639 kJ/K;
- 209.1 kJ; - 1611 kJ; - 3.419 kJ/K 8.93%

- 9.26 Determine the exergy per unit mass for the steady flow of each of the following:

- steam at 1.5 MPa, 500°C
- air at 1.5 MPa, 500°C
- water at 4 MPa, 300 K
- air at 4 MPa, 300 K
- air at 1.5 MPa, 300K

Ans. (a) 1220 kJ/kg, (b) 424 kJ/kg, (c) 3.85 kJ/kg;
(d) 316 kJ/kg, (e) 232 kJ/kg

- 9.27 A liquid ($c_p = 6$ kJ/kg K) is heated at an approximately constant pressure from 298 K to 90°C by passing it through tubes immersed in a furnace. The mass flow rate is 0.2 kg/s. Determine (a) the heating load in kW, (b) the exergy production rate in kW corresponding to the temperature rise of the fluid.

Ans. (a) 78 kW, (b) 7.44 kW

- 9.28 A flow of hot water at 80°C is used to heat cold water from 20°C to 45°C in a heat exchanger. The cold water flows at the rate of 2 kg/s. When operated in parallel mode, the exit temperature of hot water stream cannot be less than 55°C, while in the counterflow mode, it can be as low as 30°C. Assuming the

surroundings are at 300 K, compare the second law efficiencies for the two modes of operation.

- 9.29 Water at 90°C is flowing in a pipe. The pressure of the water is 3 bar, the mass flow rate is 10 kg/s, the velocity is 0.5 m/s and the elevation of the pipe is 200 m above the exit plane of the pipeline (ground level). Compute (a) the thermal exergy flux, (b) the pressure exergy flux, (c) the exergy flux from KE, (d) the exergy flux from PE, (e) total exergy flux of the stream.

Ans. (a) 260 kW, (b) 2.07 kW, (c) 1.25×10^{-3} kW,
(d) 19.6 kW, (e) 282 kW

- 9.30 A cylinder fitted with a piston contains 2 kg steam at 500 kPa, 400°C. Find the entropy change and the work done when the steam expands to a final pressure of 200 kPa in each of the following ways: (a) adiabatically and reversibly, (b) adiabatically and irreversibly to an equilibrium temperature of 300°C.

Ans. (a) 0, 386.7 kJ, (b) 0.1976 kJ/K, 309.4 kJ

- 9.31 Steam expands isentropically in a nozzle from 1 MPa, 250°C to 10 kPa. The steam flow rate is 1 kg/s. Neglecting the KE of steam at inlet to the nozzle, find the velocity of steam at exit from the nozzle and the exit area of the nozzle.

Ans. 1223 m/s, 100 cm²

- 9.32 Hot helium gas at 800°C is supplied to a steam generator and is cooled to 450°C while serving as a heat source for the generation of steam. Water enters the steam generator at 200 bar, 250°C and leaves as superheated steam at 200 bar, 500°C. The temperature of the surroundings is 27°C. For 1 kg helium, determine (a) the maximum work that could be produced by the heat removed from helium, (b) the mass of steam generated per kg of helium, (c) the actual work done in the steam cycle per kg of helium, (d) the net change for entropy of the universe, and (e) the irreversibility. Take the average c_p for helium as 5.1926 kJ/kg K and the properties of water at inlet to the steam generator as those of saturated water at 250°C.

Ans. (a) 1202.4 kJ/kg He, (b) 0.844 kg H₂O/kg He (c) 969.9 kJ/kg He,
(d) 0.775 kJ/(kg He-K), (e) 232.5 kJ/kg He

10

Properties of Gases and Gas Mixtures

10.1 Avogadro's Law

A mole of a substance has a mass numerically equal to the molecular weight of the substance.

One g mol of oxygen has a mass of 32 g, 1 kgmol of oxygen has a mass of 32 kg, 1 kgmol of nitrogen has a mass of 28 kg, and so on.

Avogadro's law states that the volume of a g mol of all gases at the pressure of 760 mm Hg and temperature of 0°C is the same, and is equal to 22.4 litres. Therefore, 1 g mol of a gas has a volume of $22.4 \times 10^3 \text{ cm}^3$ and 1 kgmole of a gas has a volume of 22.4 m^3 at normal temperature and pressure (N.T.P.).

For a certain gas, if m is its mass in kg, and μ its molecular weight, then the number of kg moles of the gas, n , would be given by

$$n = \frac{m \text{ kg}}{\mu \frac{\text{kg}}{\text{kgmol}}} = \frac{m}{\mu} \text{ kgmoles}$$

The molar volume, v , is given by

$$v = \frac{V}{n} \text{ m}^3/\text{kg mol}$$

where V is the total volume of the gas in m^3 .

10.2 Equation of State of a Gas

The functional relationship among the properties, pressure p , molar or specific volume v , and temperature T , is known as an *equation of state*, which may be expressed in the form,

$$f(p, v, T) = 0$$

If two of these properties of a gas are known, the third can be evaluated from the equation of state.

It was discussed in Chapter 2 that gas is the best-behaved thermometric substance because of the fact that the ratio of pressure p of a gas at any temperature to pressure p_t of the same gas at the triple point, as both p and p_t approach zero, approaches a value independent of the nature of the gas. The ideal gas temperature T of the system at whose temperature the gas exerts pressure p (Article 2.5) was defined as

$$T = 273.16 \lim_{p_t \rightarrow 0} \frac{p}{p_t} \quad (\text{Const. } V)$$

$$T = 273.16 \lim_{p_p \rightarrow 0} \frac{V}{V_t} \quad (\text{Const. } p)$$

The relation between pV and p of a gas may be expressed by means of a power series of the form

$$pV = A(1 + B'p + C'p^2 + \dots) \quad (10.1)$$

where A , B' , C' , etc., depend on the temperature and nature of the gas.

A fundamental property of gases is that $\lim_{p \rightarrow 0} (pV)$ is independent of the nature of the gas and depends only on T . This is shown in Fig. 10.1, where the product pV is plotted against p for four different gases in the bulb (nitrogen, air, hydrogen, and oxygen) at the boiling point of sulphur, at steam point and at the triple point of water. In each case, it is seen that as $p \rightarrow 0$, pV approaches the same value for all gases at the same temperature. From Eq. (10.1)

$$\lim_{p \rightarrow 0} pV = A$$

Therefore, the constant A is a function of temperature only and independent of the nature of the gas.

$$\lim \frac{p}{p_t} (\text{Const. } V) = \lim \frac{pV}{p_t V} = \frac{\lim pV}{\lim (pV)_t} = \frac{A}{A_t}$$

$$\lim \frac{V}{V_t} (\text{Const. } p) = \lim \frac{pV}{pV_t} = \frac{\lim pV}{\lim (pV)_t} = \frac{A}{A_t}$$

The ideal gas temperature T , is thus

$$T = 273.16 \frac{\lim pV}{\lim (pV)_t}$$

$$\therefore \lim (pV) = \left[\frac{\lim (pV)_t}{273.16} \right] T$$

The term within bracket is called the *universal gas constant* and is denoted by \bar{R} . Thus

$$\bar{R} = \frac{\lim (pV)_t}{273.16} \quad (10.2)$$

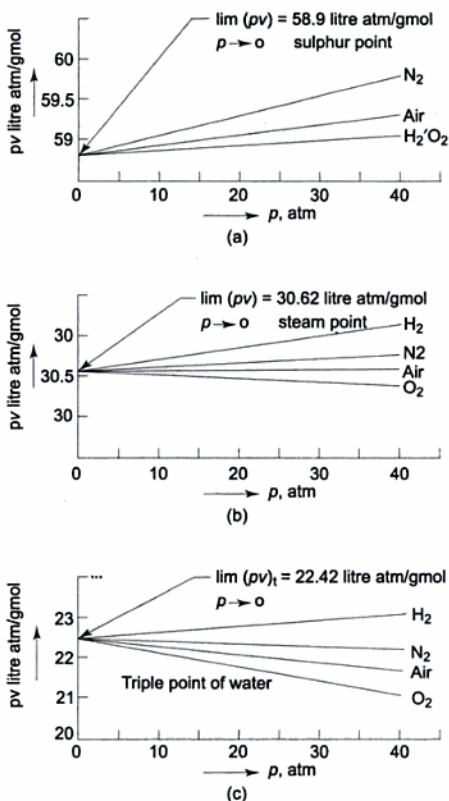

Fig. 10.1 For any gas $\lim_{p \rightarrow 0} (pv)_T$ is independent of the nature of the gas and depends only on T

The value obtained for $\lim_{p \rightarrow 0} (pv)_t$ is $22.4 \frac{\text{litre-atm}}{\text{gmol}}$

$$\therefore \bar{R} = \frac{22.4}{273.16} = 0.083 \frac{\text{litre-atm}}{\text{gmol K}}$$

The equation of state of a gas is thus

$$\lim_{p \rightarrow 0} p\bar{v} = \bar{R} T \quad (10.3)$$

where \bar{v} is the molar volume.

10.3 Ideal Gas

A hypothetical gas which obeys the law $p\bar{v} = \bar{R}T$ at all pressures and temperatures is called in *ideal gas*.

Real gases do not conform to this equation of state with complete accuracy. As $p \rightarrow 0$, or $T \rightarrow \infty$, the real gas approaches the ideal gas behaviour. In the equation $p\bar{v} = \bar{R}T$, as $T \rightarrow 0$, i.e., $t \rightarrow -273.15^\circ\text{C}$, if \bar{v} remains constant, $p \rightarrow 0$, or if p remains constant, $\bar{v} \rightarrow 0$. Since negative volume or negative pressure is inconceivable, the lowest possible temperature is 0 K or -273.15°C . T is, therefore, known as the absolute temperature.

There is no permanent or perfect gas. At atmospheric condition only, these gases exist in the gaseous state. They are subject to liquefaction or solidification, as the temperatures and pressures are sufficiently lowered.

From Avogadro's law, when $p = 760 \text{ mm Hg} = 1.013 \times 10^5 \text{ N/m}^2$, $T = 273.15 \text{ K}$, and $\bar{v} = 22.4 \text{ m}^3/\text{kgmol}$

$$\begin{aligned}\bar{R} &= \frac{1.013 \times 10^5 \times 22.4}{273.15} \\ &= 8314.3 \text{ Nm/kgmol K} \\ &= 8.3143 \text{ kJ/kgmol K}\end{aligned}$$

Since $\bar{v} = V/n$, where V is the total volume and n the number of moles of the gas, the equation of state for an ideal gas may be written as

$$pV = n\bar{R}T \quad (10.4)$$

Also
$$n = \frac{m}{\mu}$$

where μ is the molecular weight

$$\therefore pV = m \cdot \frac{\bar{R}}{\mu} \cdot T$$

or
$$pV = mRT \quad (10.5)$$

where $R = \text{characteristic gas constant} = \frac{\bar{R}}{\mu} \quad (10.6)$

For oxygen, e.g.,

$$R_{\text{O}_2} = \frac{8.3143}{32} = 0.2598 \text{ kJ/kg K}$$

For air,

$$R_{\text{air}} = \frac{8.3143}{28.96} = 0.287 \text{ kJ/kg K}$$

There are 6.023×10^{23} molecules in a g mol of a substance.

This is known as Avogadro's number (A).

$$\therefore A = 6.023 \times 10^{26} \text{ molecules/kgmol}$$

In n kg moles of gas, the total number of molecules, N , are

$$N = n A$$

or $n = N/A$

$$pV = N \frac{\bar{R}}{A} T \quad (10.7)$$

$$= NKT$$

where K = Boltzmann constant

$$= \frac{\bar{R}}{A} = \frac{8314.3}{6.023 \times 10^{26}} = 1.38 \times 10^{-23} \text{ J/molecule K}$$

Therefore, the equation of state of an ideal gas is given by

$$pV = mRT$$

$$= n\bar{R}T$$

$$= NKT$$

10.3.1 Specific Heats, Internal Energy, and Enthalpy of an Ideal Gas

An ideal gas not only satisfies the equation of state $pv = RT$, but its *specific heats are constant* also. For real gases, these vary appreciably with temperature, and little with pressure.

The properties of a substance are related by

$$Tds = du + pdv$$

or $ds = \frac{du}{T} + \frac{p}{T} dv$ (10.8)

The internal energy u is assumed to be a function of T and v , i.e.

$$u = f(T, v)$$

or $du = \left(\frac{\partial u}{\partial T}\right)_v dT + \left(\frac{\partial u}{\partial v}\right)_T dv$ (10.9)

From Eqs (10.8) and (10.9)

$$ds = \frac{1}{T} \left(\frac{\partial u}{\partial T}\right)_v dT + \frac{1}{T} \left[\left(\frac{\partial u}{\partial v}\right)_T + p \right] dv$$
 (10.10)

Again, let

$$s = f(T, v)$$

$$ds = \left(\frac{\partial s}{\partial T}\right)_v dT + \left(\frac{\partial s}{\partial v}\right)_T dv$$
 (10.11)

Comparing Eqs (10.10) and (10.11)

$$\left(\frac{\partial s}{\partial T}\right)_v = \frac{1}{T} \left(\frac{\partial u}{\partial T}\right)_v$$
 (10.12)

$$\left(\frac{\partial s}{\partial v}\right)_T = \frac{1}{T} \left[\left(\frac{\partial u}{\partial v}\right)_T + p \right] \quad (10.13)$$

Differentiating Eq. (10.12) with respect to v when T is constant

$$\frac{\partial^2 s}{\partial T \partial v} = \frac{1}{T} \frac{\partial^2 u}{\partial T \partial v} \quad (10.14)$$

Differentiating Eq. (10.13) with respect to T when v is constant

$$\frac{\partial^2 s}{\partial v \partial T} = \frac{1}{T} \frac{\partial^2 u}{\partial v \partial T} + \frac{1}{T} \left(\frac{\partial p}{\partial T}\right)_v - \frac{1}{T^2} \left(\frac{\partial u}{\partial v}\right)_T - \frac{p}{T^2} \quad (10.15)$$

From Eqs (10.14) and (10.15)

$$\frac{1}{T} \frac{\partial^2 u}{\partial T \cdot \partial v} = \frac{1}{T} \frac{\partial^2 u}{\partial v \cdot \partial T} + \frac{1}{T} \left(\frac{\partial p}{\partial T}\right)_v - \frac{1}{T^2} \left(\frac{\partial u}{\partial v}\right)_T - \frac{p}{T^2}$$

or
$$\left(\frac{\partial u}{\partial v}\right)_T + p = T \left(\frac{\partial p}{\partial T}\right)_v \quad (10.16)$$

For an ideal gas

$$pv = RT$$

$$v \left(\frac{\partial p}{\partial T}\right)_v = R$$

$$\left(\frac{\partial p}{\partial T}\right)_v = \frac{R}{v} = \frac{p}{T} \quad (10.17)$$

From Eqs (10.16) and (10.17)

$$\left(\frac{\partial u}{\partial v}\right)_T = 0 \quad (10.18)$$

Therefore, u does not change when v changes at constant temperature.

Similarly, if $u = f(T, p)$, it can be shown that $\left(\frac{\partial u}{\partial p}\right)_T = 0$. Therefore, u does

not change with p either, when T remains constant.

u does not change unless T changes.

Then
$$u = f(T) \quad (10.19)$$

only for an ideal gas. This is known as *Joule's law*.

If
$$u = f(T, v)$$

$$du = \left(\frac{\partial u}{\partial T}\right)_v dT + \left(\frac{\partial u}{\partial v}\right)_T dv$$

Since the last term is zero by Eq. (10.18), and by definition

$$c_v = \left(\frac{\partial u}{\partial T} \right)_v$$

$$du = c_v dT \quad (10.20)$$

The equation $du = c_v dT$ holds good for an ideal gas for any process, whereas for any other substance it is true for a constant volume process only.

Since c_v is constant for an ideal gas,

$$\Delta u = c_v \Delta T$$

The enthalpy of any substance is given by

$$h = u + pv$$

For an ideal gas

$$h = u + RT$$

Therefore

$$h = f(T) \quad (10.21)$$

only for an ideal gas

$$\text{Now} \quad dh = du + RdT$$

Since R is a constant

$$\begin{aligned} \Delta h &= \Delta u + R\Delta T \\ &= c_v \Delta T + R\Delta T \\ &= (c_v + R) \Delta T \end{aligned} \quad (10.22)$$

Since h is a function of T only, and by definition

$$c_p = \left(\frac{\partial h}{\partial T} \right)_p$$

$$dh = c_p dT \quad (10.23)$$

$$\text{or} \quad \Delta h = c_p \Delta T \quad (10.24)$$

From Eqs (10.22) and (10.23)

$$c_p = c_v + R$$

$$\text{or} \quad c_p - c_v = R \quad (10.25)$$

The Eq. $dh = c_p dT$ holds good for an ideal gas, even when pressure changes, but for any other substance, this is true only for a constant pressure change.

The ratio of c_p/c_v is of importance in ideal gas computations, and is designated by the symbol γ , i.e.

$$\frac{c_p}{c_v} = \gamma$$

$$\text{or} \quad c_p = \gamma c_v$$

From Eq. (10.25)

$$(\gamma - 1) c_v = R$$

and

$$\left. \begin{aligned} c_v &= \frac{R}{\gamma - 1} \\ c_p &= \frac{\gamma R}{\gamma - 1} \end{aligned} \right\} \text{kJ/kg K} \quad (10.26)$$

If $R = \frac{\bar{R}}{\mu}$ is substituted in Eq. (10.26)

and

$$\left. \begin{aligned} \bar{c}_v &= \mu c_v = (c_v)_{\text{mol}} = \frac{\bar{R}}{\gamma - 1} \\ \bar{c}_p &= \mu c_p = (c_p)_{\text{mol}} = \frac{\gamma \bar{R}}{\gamma - 1} \end{aligned} \right\} \text{kJ/(kgmol) (K)} \quad (10.27)$$

\bar{c}_v and \bar{c}_p are the *molar or molal specific heats* at constant volume and at constant pressure respectively.

It can be shown by the classical kinetic theory of gases that the values of γ are 5/3 for monatomic gases and 7/5 for diatomic gases. When the gas molecule contains more than two atoms (i.e. for polyatomic gases) the value of γ may be taken approximately as 4/3. The minimum value of γ is thus 1 and the maximum is 1.67.

The value of γ thus depends only on the molecular structure of the gas, i.e., whether the gas is monatomic, diatomic or polyatomic having one, two or more atoms in a molecule. It may be noted that c_p and c_v of an ideal gas depend only on γ and R , i.e., the number of atoms in a molecule and the molecular weight of the gas. They are independent of temperature or pressure of the gas.

10.3.2 Entropy Change of an Ideal Gas

From the general property relations

$$Tds = du + pdv$$

$$Tds = dh - vdp$$

and for an ideal gas, $du = c_v dT$, $dh = c_p dT$, and $pv = RT$, the entropy change between any two states 1 and 2 may be computed as given below

$$ds = \frac{du}{T} + \frac{p}{T} dv$$

$$= c_v \frac{dT}{T} + R \frac{dv}{v}$$

$$\therefore s_2 - s_1 = c_v \ln \frac{T_2}{T_1} + R \ln \frac{v_2}{v_1} \quad (10.28)$$

Also

$$ds = \frac{dh}{T} - \frac{v}{T} dp$$

$$= c_p \frac{dT}{T} - R \frac{dp}{p}$$

$$\text{or} \quad s_2 - s_1 = c_p \ln \frac{T_2}{T_1} - R \ln \frac{p_2}{p_1} \quad (10.29)$$

Since $R = c_p - c_v$, Eq. (10.29) may be written as

$$s_2 - s_1 = c_p \ln \frac{T_2}{T_1} - c_p \ln \frac{p_2}{p_1} + c_v \ln \frac{p_2}{p_1}$$

$$\text{or} \quad s_2 - s_1 = c_p \ln \frac{v_2}{v_1} + c_v \ln \frac{p_2}{p_1} \quad (10.30)$$

Any one of the three Eqs (10.28), (10.29), and (10.30), may be used for computing the entropy change between any two states of an ideal gas.

10.3.3 Reversible Adiabatic Process

The general property relations for an ideal gas may be written as

$$Tds = du + pdv = c_v dT + pdv$$

$$\text{and} \quad Tds = dh - vdp = c_p dT - vdp$$

For a reversible adiabatic change, $ds = 0$

$$\therefore \quad c_v dT = -pdv \quad (10.31)$$

$$\text{and} \quad c_p dT = vdp \quad (10.32)$$

By division

$$\frac{c_p}{c_v} = \gamma = - \frac{v dp}{p dv}$$

$$\text{or} \quad \frac{dp}{p} + \gamma \frac{dv}{v} = 0$$

$$\text{or} \quad d(\ln p) + \gamma d(\ln v) = d(\ln c)$$

where c is a constant.

$$\therefore \quad \ln p + \gamma \ln v = \ln c$$

$$pv^\gamma = c \quad (10.33)$$

Between any two states 1 and 2

$$p_1 v_1^\gamma = p_2 v_2^\gamma$$

$$\text{or} \quad \frac{p_2}{p_1} = \left(\frac{v_1}{v_2} \right)^\gamma$$

For an ideal gas

$$pv = RT$$

From Eq. (10.33)

$$p = c \cdot v^{-\gamma}$$

$$\begin{aligned} \therefore c \cdot v^{-\gamma} \cdot v &= RT \\ c \cdot v^{1-\gamma} &= RT \\ T v^{\gamma-1} &= \text{constant} \end{aligned} \quad (10.34)$$

Between any two states 1 and 2, for a reversible adiabatic process in the case of an ideal gas

$$\begin{aligned} T_1 v_1^{\gamma-1} &= T_2 v_2^{\gamma-1} \\ \text{or } \frac{T_2}{T_1} &= \left(\frac{v_1}{v_2} \right)^{\gamma-1} \end{aligned} \quad (10.35)$$

Similarly, substituting from Eq. (10.33)

$$\begin{aligned} v &= \left(\frac{c}{p} \right)^{1/\gamma} \text{ in the equation } p v = RT \\ p \cdot \frac{c}{p^{1/\gamma}} &= RT \\ p^{1-(1/\gamma)} \cdot c &= RT \\ \therefore T_p^{(1-\gamma)/\gamma} &= \text{constant} \end{aligned} \quad (10.36)$$

Between any two states 1 and 2

$$\begin{aligned} T_1 p_1^{(1-\gamma)/\gamma} &= T_2 p_2^{(1-\gamma)/\gamma} \\ \therefore \frac{T_2}{T_1} &= \left(\frac{p_2}{p_1} \right)^{(\gamma-1)/\gamma} \end{aligned} \quad (10.37)$$

Equations (10.33), (10.34), and (10.36) give the relations among p , v , and T in a reversible adiabatic process for an ideal gas.

The *internal energy change* of an ideal gas for a reversible adiabatic process is given by

$$\begin{aligned} T ds &= du + p dv = 0 \\ \text{or } \int_1^2 du &= - \int_1^2 p dv = - \int_1^2 \frac{c}{v^\gamma} dv \\ \text{where } p v^\gamma &= p_1 v_1^\gamma = p_2 v_2^\gamma = c \\ \therefore u_2 - u_1 &= c \frac{v_2^{1-\gamma} - v_1^{1-\gamma}}{\gamma - 1} = \frac{p_2 v_2^\gamma \cdot v_2^{1-\gamma} - p_1 v_1^\gamma \cdot v_1^{1-\gamma}}{\gamma - 1} \\ &= \frac{p_2 v_2 - p_1 v_1}{\gamma - 1} \\ &= \frac{R(T_2 - T_1)}{\gamma - 1} = \frac{RT_1}{\gamma - 1} \left(\frac{T_2}{T_1} - 1 \right) \\ &= \frac{RT_1}{\gamma - 1} \left[\left(\frac{p_2}{p_1} \right)^{\gamma-1/\gamma} - 1 \right] \end{aligned} \quad (10.38)$$

The enthalpy change of an ideal gas for a reversible adiabatic process may be similarly derived.

$$Tds = dh - vdp = 0$$

$$\text{or} \quad \int_1^2 dh = \int_1^2 vdp = \int_1^2 \frac{(c)^{1/\gamma}}{p^{1/\gamma}} dp$$

$$\text{where} \quad p_1 v_1^\gamma = p_2 v_2^\gamma = c$$

$$\begin{aligned} \therefore h_2 - h_1 &= \frac{\gamma}{\gamma - 1} c^{1/\gamma} [p_2^{(\gamma-1)/\gamma} - p_1^{(\gamma-1)/\gamma}] \\ &= \frac{\gamma}{\gamma - 1} (p_1 v_1^\gamma)^{1/\gamma} \cdot (p_1)^{(\gamma-1)/\gamma} \left[\left(\frac{p_2}{p_1} \right)^{(\gamma-1)/\gamma} - 1 \right] \\ &= \frac{\gamma p_1 v_1}{\gamma - 1} \left[\left(\frac{p_2}{p_1} \right)^{(\gamma-1)/\gamma} - 1 \right] \\ &= \frac{\gamma R T_1}{\gamma - 1} \left[\left(\frac{p_2}{p_1} \right)^{(\gamma-1)/\gamma} - 1 \right] \end{aligned} \quad (10.39)$$

The work done by an ideal gas in a reversible adiabatic process is given by

$$\delta Q = dU = \delta W = 0$$

$$\text{or} \quad \delta W = -dU$$

i.e. work is done at the expense of the internal energy.

$$\begin{aligned} \therefore W_{1-2} &= U_1 - U_2 = m(u_1 - u_2) \\ &= \frac{m(p_1 v_1 - p_2 v_2)}{\gamma - 1} = \frac{mR(T_1 - T_2)}{\gamma - 1} = \frac{mRT_1}{\gamma - 1} \left[1 - \left(\frac{p_2}{p_1} \right)^{(\gamma-1)/\gamma} \right] \end{aligned} \quad (10.40)$$

where m is the mass of gas.

In a steady flow process, where both flow work and external work are involved, we have from S.F.E.E.,

$$\begin{aligned} W_x + \Delta \frac{V^2}{2} + g\Delta z &= h_1 - h_2 = c_p(T_1 - T_2) = \frac{\gamma R(T_1 - T_2)}{\gamma - 1} \\ &= \frac{\gamma(p_1 v_1 - p_2 v_2)}{\gamma - 1} = \frac{\gamma}{\gamma - 1} p_1 v_1 \left[1 - \left(\frac{p_2}{p_1} \right)^{(\gamma-1)/\gamma} \right] \end{aligned} \quad (10.41)$$

If K.E. and P.E. changes are neglected,

$$W_x = \frac{\gamma}{\gamma - 1} p_1 v_1 \left[1 - \left(\frac{p_2}{p_1} \right)^{(\gamma-1)/\gamma} \right] \quad (10.42)$$

10.3.4 Reversible Isothermal Process

When an ideal gas of mass m undergoes a reversible isothermal process from state 1 to state 2, the work done is given by

$$\int_1^2 \delta W = \int_{V_1}^{V_2} p dV$$

$$\begin{aligned} \text{or } W_{1-2} &= \int_{V_1}^{V_2} \frac{mRT}{V} dV = mRT \ln \frac{V_2}{V_1} \\ &= mRT \ln \frac{p_1}{p_2} \end{aligned} \quad (10.43)$$

The heat transfer involved in the process

$$\begin{aligned} Q_{1-2} &= U_2 - U_1 + W_{1-2} \\ &= W_{1-2} = mRT \ln V_2/V_1 = T(S_2 - S_1) \end{aligned} \quad (10.44)$$

10.3.5 Polytropic Process

An equation of the form $pv^n = \text{constant}$, where n is a constant can be used approximately to describe many processes which occur in practice. Such a process is called a *polytropic process*. It is not adiabatic, but it can be reversible. It may be noted that γ is a property of the gas, whereas n is not. The value of n depends upon the process. It is possible to find the value of n which more or less fits the experimental results. For two states on the process,

$$p_1 v_1^n = p_2 v_2^n \quad (10.45)$$

$$\begin{aligned} \text{or } \left(\frac{v_2}{v_1} \right)^n &= \frac{p_1}{p_2} \\ n &= \frac{\log p_1 - \log p_2}{\log v_2 - \log v_1} \end{aligned} \quad (10.46)$$

For known values of p_1 , p_2 , v_1 and v_2 , n can be estimated from the above relation.

Two other relations of a polytropic process, corresponding to Eqs (10.35) and (10.37), are

$$\frac{T_2}{T_1} = \left(\frac{v_1}{v_2} \right)^{n-1} \quad (10.47)$$

$$\frac{T_2}{T_1} = \left(\frac{p_2}{p_1} \right)^{n-1/n} \quad (10.48)$$

(i) **Entropy Change in a Polytropic Process** In a reversible adiabatic process, the entropy remains constant. But in a reversible polytropic process, the

entropy changes. Substituting Eqs (10.45), (10.47) and (10.48) in Eqs (10.28), (10.29) and (10.30), we have three expressions for entropy change as given below

$$\begin{aligned} s_2 - s_1 &= c_v \ln \frac{T_2}{T_1} + R \ln \frac{v_2}{v_1} \\ &= \frac{R}{\gamma - 1} \ln \frac{T_2}{T_1} + \frac{R}{n - 1} \ln \frac{T_1}{T_2} \\ &= \frac{n - \gamma}{(\gamma - 1)(n - 1)} R \ln \frac{T_2}{T_1} \end{aligned} \quad (10.49)$$

Relations in terms of pressure and specific volume can be similarly derived. These are

$$s_2 - s_1 = \frac{n - \gamma}{n(\gamma - 1)} R \ln \frac{p_2}{p_1} \quad (10.50)$$

and

$$s_2 - s_1 = - \frac{n - \gamma}{\gamma - 1} R \ln \frac{v_2}{v_1} \quad (10.51)$$

It can be noted that when $n = \gamma$, the entropy change becomes zero. If $p_2 > p_1$, for $n \leq \gamma$, the entropy of the gas decreases, and for $n > \gamma$, the entropy of the gas increases. The increase of entropy may result from reversible heat transfer to the system from the surroundings. Entropy decrease is also possible if the gas is cooled.

(ii) Heat and Work in a Polytropic Process Using the first law to unit mass of an ideal gas,

$$\begin{aligned} Q - W &= u_2 - u_1 \\ &= c_v(T_2 - T_1) = \frac{R(T_2 - T_1)}{\gamma - 1} \\ &= \frac{p_2 v_2 - p_1 v_1}{\gamma - 1} \\ &= \frac{p_1 v_1}{\gamma - 1} \left[\left(\frac{p_2}{p_1} \right)^{n-1/n} - 1 \right] = \frac{p_1 v_1}{\gamma - 1} \left[\left(\frac{v_1}{v_2} \right)^{n-1} - 1 \right] \end{aligned} \quad (10.52)$$

For a steady flow system of unit mass of ideal gas, the S.F.E.E. Eq. (5.10), gives

$$\begin{aligned} Q &= W_x - \Delta \left[\frac{\bar{V}^2}{2} + gz \right] = h_2 - h_1 \\ &= c_p(T_2 - T_1) = \frac{\gamma R(T_2 - T_1)}{\gamma - 1} \\ &= \frac{\gamma}{\gamma - 1} (p_2 v_2 - p_1 v_1) \end{aligned} \quad (10.53)$$

For a polytropic process,

$$\begin{aligned}
 Q - W_x &= \Delta \left[\frac{\bar{V}^2}{2} + gz \right] = \frac{\gamma p_1 v_1}{\gamma - 1} \left[\left(\frac{p_2}{p_1} \right)^{n-1/n} - 1 \right] \\
 &= \frac{\gamma p_1 v_1}{\gamma - 1} \left[\left(\frac{v_1}{v_2} \right)^{n-1} - 1 \right] \quad (10.54)
 \end{aligned}$$

Equations (10.52) and (10.54) can be used to determine heat and work quantities for a closed and a steady flow system respectively.

(iii) **Integral Property Relations in a Polytropic Process** In a $pv^n = \text{constant}$ process,

$$\begin{aligned}
 \int_1^2 p dv &= \int_1^2 \frac{p_1 v_1^n}{v^n} dv = \frac{p_1 v_1}{n-1} \left[1 - \left(\frac{v_1}{v_2} \right)^{n-1} \right] \\
 &= \frac{p_1 v_1}{n-1} \left[1 - \left(\frac{p_2}{p_1} \right)^{n-1/n} \right] \quad (10.55)
 \end{aligned}$$

Similarly,

$$\begin{aligned}
 -\int_1^2 v dp &= \frac{n p_1 v_1}{n-1} \left[1 - \left(\frac{v_1}{v_2} \right)^{n-1} \right] \\
 &= \frac{n p_1 v_1}{n-1} \left[1 - \left(\frac{p_2}{p_1} \right)^{n-1/n} \right] \quad (10.56)
 \end{aligned}$$

The integral of Tds is obtained from the property relation

$$Tds = du + pdv$$

$$\begin{aligned}
 \therefore \int_1^2 Tds &= \int_1^2 du + \int_1^2 pdv \\
 &= u_2 - u_1 + \int_1^2 pdv
 \end{aligned}$$

Substituting from Eqs (10.50) and (10.53)

$$\begin{aligned}
 \int_1^2 Tds &= \frac{\gamma - n}{(\gamma - 1)(n - 1)} p_1 v_1 \left[1 - \left(\frac{p_2}{p_1} \right)^{n-1/n} \right] \\
 &= \frac{\gamma - n}{(\gamma - 1)(n - 1)} p_1 v_1 \left[1 - \left(\frac{v_1}{v_2} \right)^{n-1} \right] \\
 &= \frac{\gamma - n}{(\gamma - 1)(n - 1)} R(T_1 - T_2) \quad (10.57)
 \end{aligned}$$

Since $R/(\gamma - 1) = c_v$, and putting $\Delta T = T_2 - T_1$, the reversible heat transfer

$$\begin{aligned} Q_R &= \int_1^2 T ds = c_v \frac{\gamma - n}{n - 1} \Delta T \\ &= c_n \Delta T \end{aligned} \quad (10.58)$$

Where $c_n = c_v (\gamma - n)/(1 - n)$ is called the polytropic specific heat. For $n > \gamma$ there will be positive heat transfer and gain in entropy. For $n < \gamma$, heat transfer will be negative and entropy of the gas would decrease.

Ordinarily both heat and work are involved in a polytropic process. To evaluate the heat transfer during such a process, it is necessary to first evaluate the work via either $\int p dv$ or $-\int v dp$, depending on whether it is a closed or an open steady flow system. The application of the first law will then yield the heat transfer.

The polytropic processes for various values of n are shown in Fig. 10.2 on the p - v and T - s diagrams.

$$pv^n = C$$

On differentiation,

$$\begin{aligned} v^n dp + pnv^{n-1} dv &= 0 \\ \frac{dp}{dv} &= -n \frac{p}{v} \end{aligned} \quad (10.59)$$

The slope of the curve increases in the negative direction with increase of n . The values of n for some familiar processes are given below

Isobaric process ($p = c$), $n = 0$

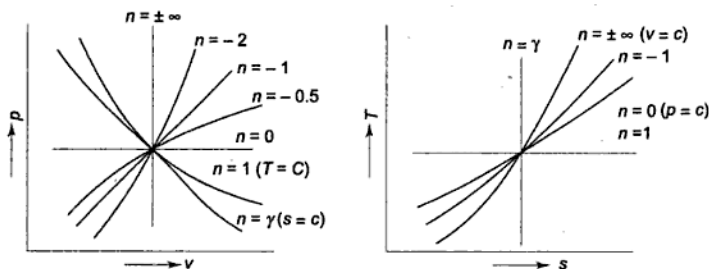

Fig. 10.2 Process in which $pv^n = \text{constant}$

Isothermal process ($T = c$), $n = 1$

Isentropic process ($s = c$), $n = \gamma$

Isometric or isochoric process ($v = c$), $n = \infty$.

10.4 Gas Compression

A gas compressor is a device in which work is done on the gas to raise its pressure, with an appreciable increase in its density. Being a steady flow device the external work done, in absence of K.E. and P.E. changes, would be

$$W_x = - \int_1^2 v \, dp = h_1 - h_2$$

For a reversible polytropic compression process, $p v^n = c$

$$W_x = \frac{n}{n-1} p_1 v_1 \left[\left(\frac{p_2}{p_1} \right)^{(n-1)/n} - 1 \right]$$

For reversible adiabatic compression, n is substituted by γ . For reversible isothermal compression, the work of compression becomes

$$W_x = p_1 v_1 \ln \frac{p_2}{p_1}$$

Figure 10.3 shows the three reversible compression processes. From Eq. (10.59), the slope at state 1 is given by

$$\frac{dp}{dv} = -n \frac{p_1}{v_1}$$

For $\gamma > n > 1$ and for the same pressure ratio p_2/p_1 , the isothermal compression needs the minimum work, whereas adiabatic compression needs the maximum work, while the polytropic compression needing work in between the two. It may be noted in Fig. 10.3, that in process 0-1 the gas is sucked in a reciprocating compressor, in process 1-2 (2_T , 2_n or 2_s , as the case may be) the gas is compressed, and in process 2-3 the gas is discharged. The clearance volume is here neglected. The work of compression is the area included in the diagram as shown.

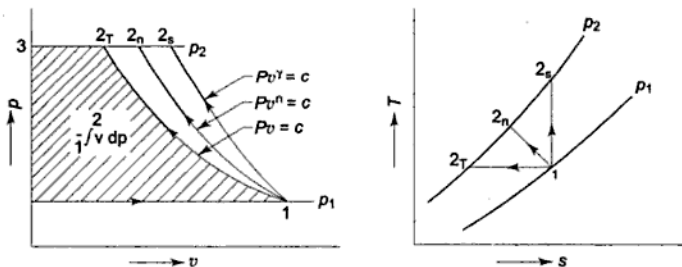

Fig. 10.3 Reversible compression processes

10.4.1 Multistage Compression

By staging the compression process with intermediate cooling, the work of compression can be reduced. In an ideal two-stage compressor, as shown in Fig. 10.4, the gas is first compressed isentropically in the low pressure (L.P.) cylinder, process 1-2, it is cooled in the intercooler at constant pressure to its original temperature (called *perfect intercooling*), process 2-3, and it is then compressed isentropically in the high pressure (H.P.) cylinder, process 3-4.

The total work of compression per unit mass in the two adiabatic cylinders is

$$W_c = (h_2 - h_1) + (h_4 - h_3) \quad (10.60)$$

If the working fluid is an ideal gas with constant specific heats,

$$W_c = c_p (T_2 - T_1) + c_p (T_4 - T_3)$$

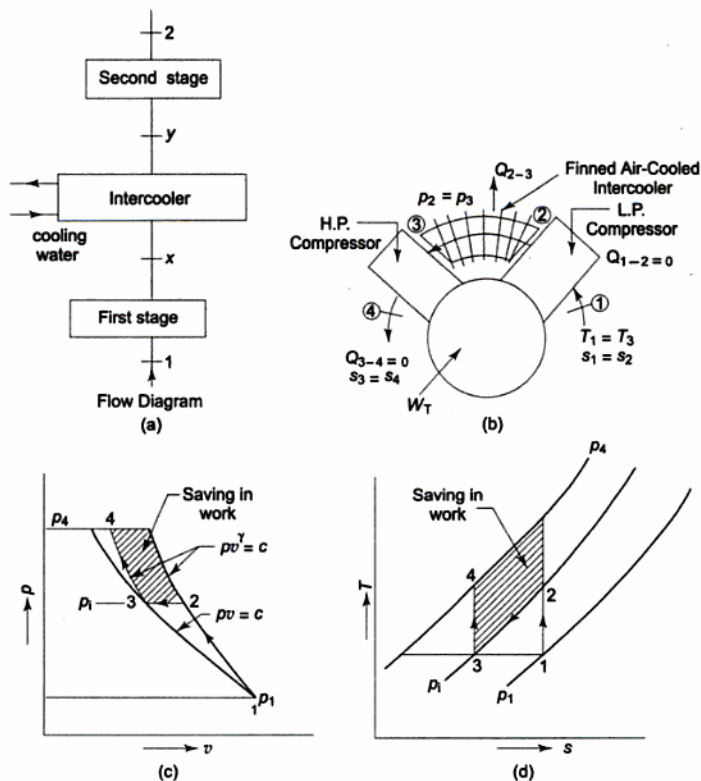

Fig. 10.4 Two-stage compression with intercooling

$$\begin{aligned}
 &= c_p T_1 \left(\frac{T_2}{T_1} - 1 \right) + c_p T_3 \left(\frac{T_4}{T_3} - 1 \right) \\
 &= c_p T_1 \left[\left(\frac{p_2}{p_1} \right)^{(\gamma-1)/\gamma} - 1 \right] + c_p T_3 \left[\left(\frac{p_4}{p_3} \right)^{(\gamma-1)/\gamma} - 1 \right]
 \end{aligned}$$

with perfect intercooling, $T_1 = T_3$ and $p_2 = p_3$

$$W_c = c_p T_1 \left[\left(\frac{p_2}{p_1} \right)^{(\gamma-1)/\gamma} + \left(\frac{p_4}{p_3} \right)^{(\gamma-1)/\gamma} - 2 \right] \quad (10.61)$$

For minimum work

$$\frac{dW_c}{dp_2} = c_p T_1 \left[\frac{\gamma-1}{\gamma} \frac{p_2^{-1/\gamma}}{p_1^{(\gamma-1)/\gamma}} + \left(\frac{1-\gamma}{\gamma} \right) p_2^{1-2\gamma/\gamma} p_4^{\gamma-1/\gamma} \right] = 0$$

$$\therefore p_2^{2(\gamma-1)/\gamma} = (p_1 p_4)^{(\gamma-1)/\gamma}$$

$$\therefore p_2 = \sqrt{p_1 p_4} \quad (10.62)$$

Thus, for minimum work the intermediate pressure p_2 (or p_3) is the geometric mean of the suction and discharge pressures.

From Eq. (10.62) it follows that

$$\frac{p_2}{p_1} = \frac{p_4}{p_2} = \frac{p_4}{p_3} \quad (10.63)$$

Since $\frac{T_2}{T_1} = \left[\frac{p_2}{p_1} \right]^{(\gamma-1)/\gamma}$, $\frac{T_4}{T_3} = \left[\frac{p_4}{p_3} \right]^{(\gamma-1)/\gamma}$

and $T_1 = T_3$, $\therefore T_4 = T_2$

Also, $\frac{p_2}{p_1} = \frac{p_4}{p_1} \frac{p_1}{p_2}$

$$\frac{p_2}{p_1} = \left[\frac{p_4}{p_1} \right]^{1/2}$$

For a 3 stage compressor, the pressure ratio per stage is:

$$\frac{p_2}{p_1} = \left[\frac{p_4}{p_1} \right]^{1/3}$$

Thus, the intermediate pressure that produces minimum work will also result in equal pressure ratios in the two stages of compression, equal discharge temperatures, and equal work for the two stages.

For ideal two-stage adiabatic compression, the minimum work, using Eqs (10.61) and (10.63), becomes

$$W_c = \frac{2\gamma RT_1}{\gamma-1} \left[\left(\frac{p_2}{p_1} \right)^{(\gamma-1)/\gamma} - 1 \right] \quad (10.64)$$

Similarly, for reversible polytropic compression, $pv^n = c$, with perfect intercooling, the same expressions given by Eqs (10.61) and (10.62) can be obtained by substituting n for γ , and the minimum work becomes

$$W_c = \frac{2nRT_1}{n-1} \left[\left(\frac{p_2}{p_1} \right)^{n-1/n} - 1 \right] \quad (10.65)$$

The heat rejected in the intercooler is

$$Q_{2-3} = c_p (T_2 - T_3)$$

If there are N stages of compression, the pressure ratio in each stage can be shown to be

$$\frac{p_2}{p_1} = \left(\frac{\text{discharge pressure}}{\text{suction pressure}} \right)^{1/N} \quad (10.66)$$

The total work of compression for N stages is

$$W_c = \frac{2NnRT_1}{n-1} \left[\left(\frac{P_{\text{discharge}}}{P_{\text{suction}}} \right)^{(n-1)/Nn} - 1 \right] \quad (10.67)$$

In the case of gas compression, the desirable idealized process is often a reversible isothermal process. The isothermal efficiency, η_t , of a compressor is defined as

$$\eta_t = \frac{W_t}{W_c} = \frac{p_1 v_1 \ln \frac{p_2}{p_1}}{W_c}$$

10.4.2 Volumetric Efficiency

The ratio of the actual volume of gas taken into the cylinder during suction stroke to the piston displacement volume is called *volumetric efficiency*. If \dot{m} is the mass flow rate of gas and v_1 is the specific volume of gas at inlet to the compressor, and PD is the piston displacement per cycle, then volumetric efficiency is given by

$$\eta_{\text{vol}} = \frac{\dot{m}v_1}{PD} \quad (10.68)$$

Let us imagine an idealized reciprocator in which there are no pressure losses and the processes 3-0 and 1-2 are reversible polytropic processes (Fig. 10.5), with equal value of n . The clearance volume (CV) is the volume V_3 of the cylinder and the process 3-0 represents the expansion of the air in the CV . The volumetric efficiency is then given by

$$\eta_{\text{vol}} = \frac{V_1 - V_0}{V_1 - V_3}$$

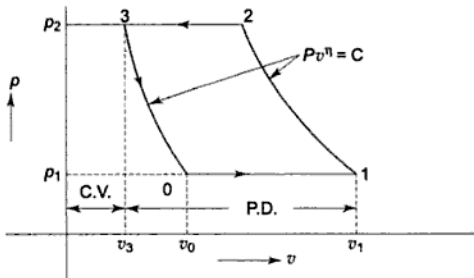

Fig. 10.5 Processes in an idealized reciprocating compressor

$$= 1 - \frac{V_0 - V_3}{V_1 - V_3} \quad (10.69)$$

Clearance C is defined as

$$C = \frac{\text{Clearance volume}}{PD}$$

$$= \frac{V_3}{V_1 - V_3} \quad (10.70)$$

Now

$$\frac{V_0}{V_3} = \frac{v_0}{v_3} = \left(\frac{p_2}{p_3} \right)^{1/n} \quad (10.71)$$

$$\eta_{\text{vol}} = 1 - \frac{V_3 \left(\frac{p_2}{p_1} \right)^{1/n} - V_3}{V_3} \cdot C$$

$$\therefore \eta_{\text{vol}} = 1 - C \left[\left(\frac{p_2}{p_1} \right)^{1/n} - 1 \right]$$

$$= 1 + C - C \left(\frac{p_2}{p_1} \right)^{1/n} \quad (10.72)$$

Equation (10.72) is plotted in Fig. 10.6. Noting that $(p_2/p_1)^{1/n}$ is always greater than unity, it is evident that the volumetric efficiency decreases as the clearance increases and as the pressure ratio increases.

In order to get maximum flow capacity, compressors are built with the minimum clearance. Sometimes, however, the clearance is deliberately increased as a means of controlling the flow through the compressor driven by a constant speed motor.

It is evident from Fig. 10.6 that as the pressure ratio is increased, the volumetric efficiency of a compressor of fixed clearance decreases, eventually

becoming zero. This can also be seen in an indicator diagram, Fig. 10.7. As the discharge pressure is increased, the volume V_1 , taken in at p_1 , decreases. At some pressure p_{2c} the compression line intersects the line of clearance volume and there is no discharge of gas. An attempt to pump to p_{2c} (or any higher pressure) would result in compression and re-expansion of the same gas repeatedly, with no flow in or out. The maximum pressure ratio attainable with a reciprocating compressor is thus limited by the clearance. The clearance cannot be reduced beyond a certain value, then to attain the desired discharge pressure, multistage compression is to be used, where the overall pressure ratio is the product of the pressure ratios of the stages.

The mass flow rate of gas from Eq. (10.68) then becomes

$$\dot{m} = \frac{PD}{v_1} \eta_{\text{vol}} = \frac{PD}{v_1} \left[1 + C - C \left(\frac{p_2}{p_1} \right)^{1/n} \right] \quad (10.73)$$

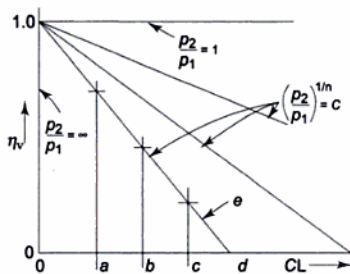

Fig. 10.6 Effect of clearance on volumetric efficiency

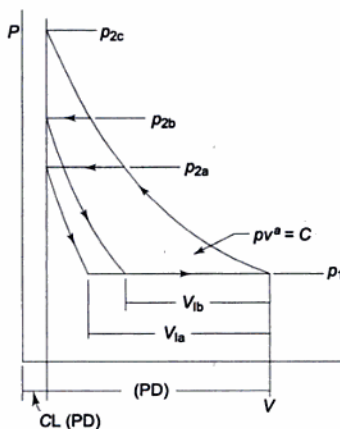

Fig. 10.7 Effect of pressure ratio on capacity

10.5 Equations of State

The ideal gas equation of state $p\bar{v} = \bar{R}T$ can be established from the postulates of the kinetic theory of gases developed by Clerk Maxwell, with two important assumptions that there is little or no attraction between the molecules of the gas and that the volume occupied by the molecules themselves is negligibly small compared to the volume of the gas. When pressure is very small or temperature very large, the intermolecular attraction and the volume of the molecules compared to the total volume of the gas are not of much significance, and the real gas obeys very closely the ideal gas equation. But as pressure increases, the intermolecular forces of attraction and repulsion increase, and also the volume of the molecules becomes appreciable compared to the gas volume. So then the real gases deviate considerably from the ideal gas equation. van der Waals, by applying the laws of mechanics to individual molecules, introduced two correction terms in the equation of ideal gas, and his equation is given below.

$$\left(p + \frac{a}{v^2}\right)(v - b) = RT \quad (10.74)$$

The coefficient a was introduced to account for the existence of mutual attraction between the molecules. The term a/v^2 is called the *force of cohesion*. The coefficient b was introduced to account for the volumes of the molecules, and is known as *co-volume*.

Real gases conform more closely with the van der Waals equation of state than the ideal gas equation of state, particularly at higher pressures. But it is not obeyed by a real gas in all ranges of pressures and temperatures. Many more equations of state were later introduced, and notable among these are the equations developed by Berthelot, Dieterici, Beattie-Bridgeman, Kammerlingh Onnes, Hirshfelder-Bird-Spotz-McGee-Sutton, Wohl, Redlich-Kwong, and Martin-Hou.

Apart from the van der Waals equation, three two-constant equations of state are those of Berthelot, Dieterici, and Redlich-Kwong, as given below:

$$\text{Berthelot:} \quad p = \frac{RT}{v - b} - \frac{a}{Tv^2} \quad (10.75)$$

$$\text{Dieterici:} \quad p = \frac{RT}{v - b} \cdot e^{-a/RTv} \quad (10.76)$$

$$\text{Redlich-Kwong:} \quad p = \frac{RT}{v - b} - \frac{a}{T^{1/2}v(v + b)} \quad (10.77)$$

The constants, a and b are evaluated from the critical data, as shown for van der Waals equation in article 10.7. The Berthelot and Dieterici equations of state, like the van der Waals equation, are of limited accuracy. But the Redlich-Kwong equation gives good results at high pressures and is fairly accurate for temperatures above the critical value.

Another two-constant equation which is again of limited accuracy is the Saha-Bose equation of state given as follows.

$$p = -\frac{RT}{2b} e^{-a/RTv} \ln\left(\frac{v-2b}{v}\right) \quad (10.78)$$

It is, however, quite accurate for densities less than about 0.8 times the critical density.

One more widely used equation of state with good accuracy is the Beattie-Bridgeman equation:

$$p = \frac{RT(1-e)}{v^2}(v+B) - \frac{A}{v^2} \quad (10.79)$$

where

$$A = A_0 \left(1 - \frac{a}{v}\right), B = B_0 \left(1 - \frac{b}{v}\right), e = \frac{c}{vT^3}$$

There are five constants, A_0 , B_0 , a , b , and c , which have to be determined experimentally for each gas. The Beattie-Bridgeman equation does not give satisfactory results in the critical point region.

All these equations mentioned above reduce to the ideal gas equation for large volumes and temperatures and for very small pressures.

10.6 Virial Expansions

The relation between $p\bar{v}$ and p in the form of power series, as given in Eq. (10.1), may be expressed as

$$p\bar{v} = A(1 + B'p + C'p^2 + D'p^3 + \dots)$$

For any gas, from equation (10.3)

$$\lim_{p \rightarrow 0} p\bar{v} = A = \bar{R}T$$

$$\therefore \frac{p\bar{v}}{\bar{R}T} = 1 + B'p + C'p^2 + D'p^3 + \dots \quad (10.80)$$

An alternative expression is

$$\frac{p\bar{v}}{\bar{R}T} = 1 + \frac{B}{\bar{v}} + \frac{C}{\bar{v}^2} + \frac{D}{\bar{v}^3} + \dots \quad (10.81)$$

Both expressions in Eqs (10.80) and (10.81) are known as virial expansions or virial equations of state, first introduced by the Dutch physicist, Kammerlingh Onnes. B' , C' , B , C , etc. are called *virial coefficients*. B' and B are called second virial coefficients, C' and C are called third virial coefficients, and so on. For a given gas, these coefficients are functions of temperature only.

The ratio $p\bar{v}/\bar{R}T$ is called the compressibility factor, Z . For an ideal gas $Z = 1$. The magnitude of Z for a certain gas at a particular pressure and temperature gives an indication of the extent of deviation of the gas from the ideal gas behaviour. The virial expansions become

$$Z = 1 + B'p + C'p^2 + D'p^3 + \dots \quad (10.82)$$

and

$$Z = 1 + \frac{B}{\bar{v}} + \frac{C}{\bar{v}^2} + \frac{D}{\bar{v}^3} + \dots \quad (10.83)$$

The relations between B' , C' , and B , C , ... can be derived as given below

$$\begin{aligned} \frac{p\bar{v}}{RT} &= 1 + B'p + C'p^2 + D'p^3 + \dots \\ &= 1 + B' \left[\frac{\bar{R}T}{\bar{v}} \left(1 + \frac{B}{\bar{v}} + \frac{C}{\bar{v}^2} + \dots \right) \right] \\ &\quad + C' \left[\left(\frac{\bar{R}T}{\bar{v}} \right)^2 \left(1 + \frac{B}{\bar{v}} + \frac{C}{\bar{v}^2} + \dots \right)^2 \right] + \dots \\ &= 1 + \frac{B' \bar{R}T}{\bar{v}} + \frac{B' B \bar{R}T + C' (\bar{R}T)^2}{\bar{v}^2} \\ &\quad + \frac{B' \bar{R}TC + C' (\bar{R}T)^2 + D' (\bar{R}T)^3}{\bar{v}^3} + \dots \end{aligned} \quad (10.84)$$

Comparing this equation with Eq. (10.81) and rearranging

$$\begin{aligned} B' &= \frac{B}{\bar{R}T}, \quad C' = \frac{C - B^2}{(\bar{R}T)^2}, \\ D' &= \frac{D - 3BC + 2B^3}{(\bar{R}T)^3}, \text{ and so on} \end{aligned}$$

Therefore

$$\begin{aligned} Z &= \frac{p\bar{v}}{RT} = 1 + B'p + C'p^2 + \dots \\ &= 1 + \frac{B}{\bar{R}T}p + \frac{C - B^2}{(\bar{R}T)^2}p^2 + \dots \end{aligned} \quad (10.85)$$

The terms B/\bar{v} , C/\bar{v}^2 etc. of the virial expansion arise on account of molecular interactions. If no such interactions exist (at very low pressures) $B = 0$, $C = 0$, etc., $Z = 1$ and $p\bar{v} = \bar{R}T$.

10.7 Law of Corresponding States

For a certain gas, the compressibility factor Z is a function of p and T [Eq. (10.85)], and so a plot can be made of lines of constant temperature on coordinates of p and Z (Fig. 10.8). From this plot Z can be obtained for any value of p and T , and the volume can then be obtained from the equation $p\bar{v} = ZRT$. The advantage of using Z instead of a direct plot of \bar{v} is a smaller range of values in plotting.

For each substance, there is a compressibility factor chart. It would be very convenient if one chart could be used for all substances. The general shapes of the

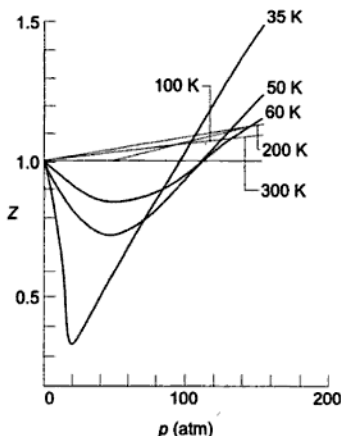

Fig. 10.8 Variation of the compressibility factor of hydrogen with pressure at constant temperature

vapour dome and of the constant temperature lines on the p - v plane are similar for all substances, although the scales may be different. This similarity can be exploited by using dimensionless properties called *reduced properties*. The reduced pressure is the ratio of the existing pressure to the critical pressure of the substance, and similarly for reduced temperature and reduced volume. Then

$$p_r = \frac{p}{p_c}, T_r = \frac{T}{T_c}, v_r = \frac{v}{v_c}$$

where subscript r denotes the reduced property, and subscript c denotes the property at the critical state.

At the same pressure and temperature the specific or molal volumes of different gases are different. However, it is found from experimental data that at the same reduced pressure and reduced temperature, the reduced volumes of different gases are approximately the same. Therefore, for all substances

$$v_r = f(p_r, T_r) \quad (10.86)$$

Now,

$$v_r = \frac{v}{v_c} = \frac{ZRTp_c}{Z_cRT_c p} = \frac{Z}{Z_c} \cdot \frac{T_r}{p_r} \quad (10.87)$$

where $Z_c = \frac{p_c v_c}{RT_c}$. This is called the critical compressibility factor. Therefore

from Eqs (10.86) and (10.87),

$$Z = f(p_r, T_r, Z_c) \quad (10.88)$$

Experimental values of Z_c for most substances fall within a narrow range 0.20–0.30. Therefore, Z_c may be taken to be a constant and Eq. (10.88) reduces to

$$Z = f(p_r, T_r) \quad (10.89)$$

When T_r is plotted as a function of reduced pressure and Z , a single plot, known as the *generalized compressibility chart*, is found to be satisfactory for a great variety of substances. Although necessarily approximate, the plots are extremely useful in situations where detailed data on a particular gas are lacking but its critical properties are available.

The relation among the reduced properties, p_r , T_r , and v_r , is known as the law of *corresponding states*. It can be derived from the various equations of state, such as those of van der Waals, Berthelot, and Dieterici. For a van der Waals gas,

$$\left(p + \frac{a}{v^2}\right)(v - b) = RT$$

where a , b , and R are the characteristic constants of the particular gas.

$$p = \frac{RT}{v - b} - \frac{a}{v^2}$$

or
$$pv^3 - (pb + RT)v^2 + av - ab = 0$$

It is therefore a cubic in v and for given values of p and T has three roots of which only one need be real. For low temperatures, three positive real roots exist for a certain range of pressure. As the temperature increases the three real roots approach one another and at the critical temperature they become equal. Above this temperature only one real root exists for all values of p . The critical isotherm T_c at the critical state on the p - v plane (Fig. 10.9), where the three real roots of the van der Waals equation coincide, not only has a zero slope, but also its slope changes at the critical state (point of inflection), so that the first and second derivatives of p with respect to v at $T = T_c$ are each equal to zero. Therefore

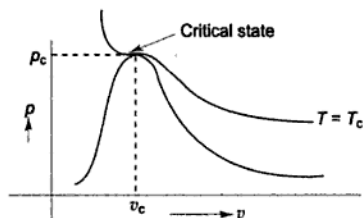

Fig. 10.9 Critical properties on p - v diagram

$$\left(\frac{\partial p}{\partial v}\right)_{T=T_c} = -\frac{RT_c}{(v_c - b)^2} + \frac{2a}{v_c^3} = 0 \quad (10.90)$$

$$\left(\frac{\partial^2 p}{\partial v^2}\right)_{T=T_c} = \frac{2 \cdot RT_c}{(v_c - b)^3} - \frac{6a}{v_c^4} = 0 \quad (10.91)$$

From these two equations, by rearranging and dividing, $b = \frac{1}{3} v_c$.

Substituting the value of b in Eq. (10.90)

$$R = \frac{8a}{9T_c v_c}$$

Substituting the values of b and R in Eq. (10.74)

$$\left(p_c + \frac{a}{v_c^2}\right)\left(\frac{2}{3}v_c\right) = \frac{8a}{9T_c v_c} \cdot T_c$$

$$a = 3p_c v_c^2$$

Therefore, the value of R becomes

$$R = \frac{8}{3} \frac{p_c v_c}{T_c}$$

The values of a , b and R have thus been expressed in terms of critical properties. Substituting these in the van der Waals equation of state

$$\left(p + \frac{3p_c v_c^2}{v^2}\right)\left(v - \frac{1}{3}v_c\right) = \frac{8}{3} \frac{p_c v_c}{T_c} T$$

$$\text{or,} \quad \left(\frac{p}{p_c} + \frac{3v_c^2}{v^2}\right)\left(\frac{v}{v_c} - \frac{1}{3}\right) = \frac{8}{3} \frac{T}{T_c}$$

Using the reduced parameters,

$$\therefore \quad \left(p_r + \frac{3}{v_r^2}\right)(3v_r - 1) = 8T_r \quad (10.92)$$

In the reduced equation of state (10.92) the individual coefficients a , b and R for a particular gas have disappeared. So this equation is an expression of the *law of corresponding states* because it reduces the properties of all gases to one formula. It is a 'law' to the extent that real gases obey van der Waals equation. Two different substances are considered to be in 'corresponding states', if their pressures, volumes and temperatures are of the same fractions (or multiples) of the critical pressure, volume and temperatures are of two substances. The *generalized compressibility* chart in terms of reduced properties is shown in Fig. 10.10. It is very useful in predicting the properties of substances for which more precise data are not available. The value of Z at the critical state for a van der Waals gas is 0.375 (since $R = \frac{8}{3} \frac{p_c v_c}{T_c}$). At very low pressures Z approaches unity, as a real gas approaches the ideal gas behaviour. Equation (10.92) can also be written in the following form

$$\left(p_r v_r + \frac{3}{v_r}\right)(3v_r - 1) = 8T_r v_r$$

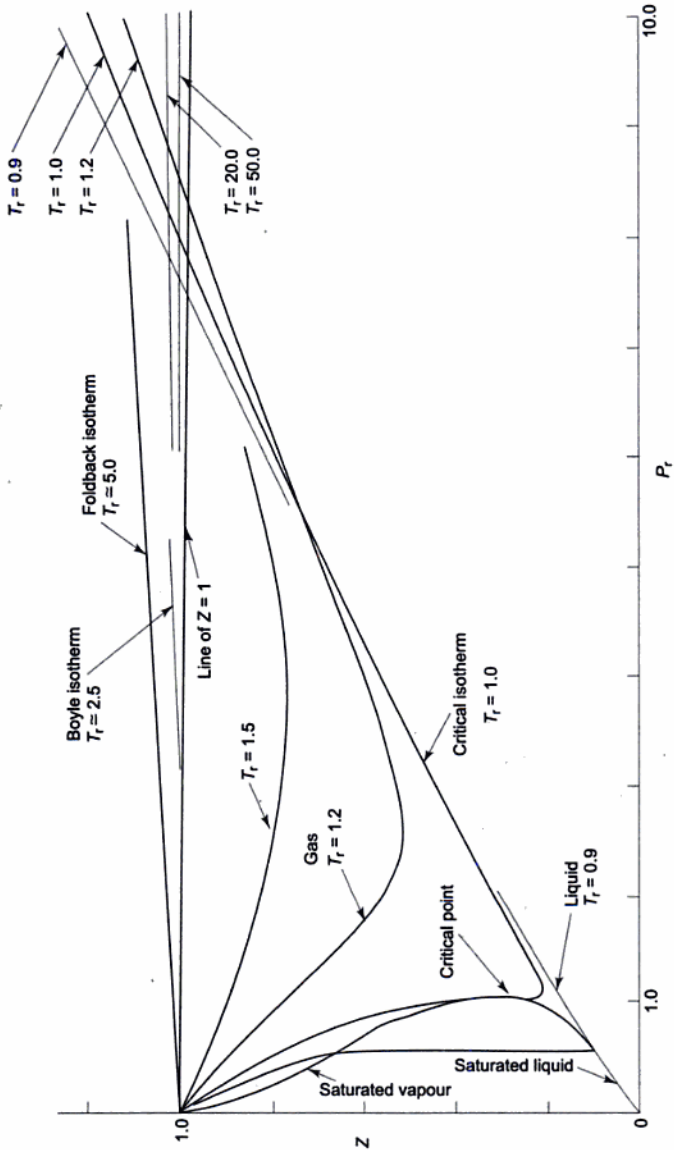

Fig. 10.10 (a) Generalized compressibility chart

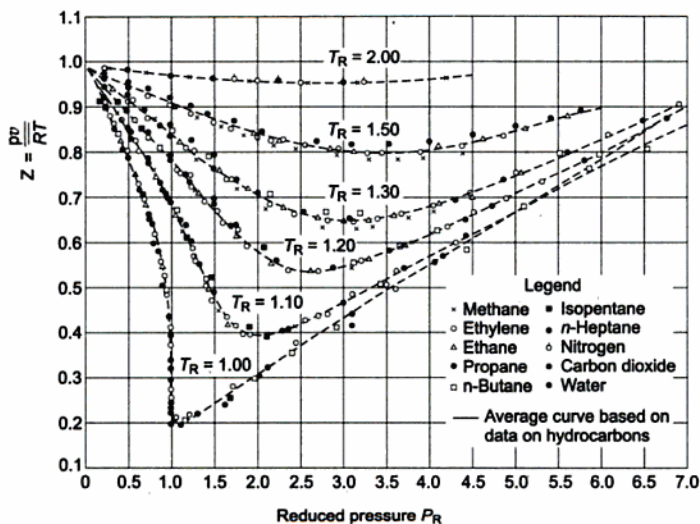

Fig. 10.10 (b) Generalized compressibility chart

$$\therefore p_r v_r = \frac{8 T_r v_r}{3 v_r - 1} - \frac{3}{v_r} \quad (10.93)$$

Figure 10.11 shows the law of corresponding states in reduced coordinates, $(p_r v_r)$ vs. p_r . Differentiating Eq. (10.93) with respect to p_r and making it equal to zero, it is possible to determine the minima of the isotherms as shown below.

$$\frac{\partial}{\partial p_r} \left[\frac{8 T_r v_r}{3 v_r - 1} - \frac{3}{v_r} \right]_{T_r} = 0$$

$$\text{or} \quad \frac{\partial}{\partial v_r} \left[\frac{8 T_r v_r}{3 v_r - 1} - \frac{3}{v_r} \right]_{T_r} \left[\frac{\partial v_r}{\partial p_r} \right]_{T_r} = 0$$

$$\text{Since} \quad \left[\frac{\partial v_r}{\partial p_r} \right]_{T_r} \neq 0$$

$$\frac{\partial}{\partial v_r} \left[\frac{8 T_r v_r}{3 v_r - 1} - \frac{3}{v_r} \right]_{T_r} = 0$$

$$\therefore \quad \frac{8 T_r}{(3 v_r - 1)^2} = \frac{3}{v_r^2}$$

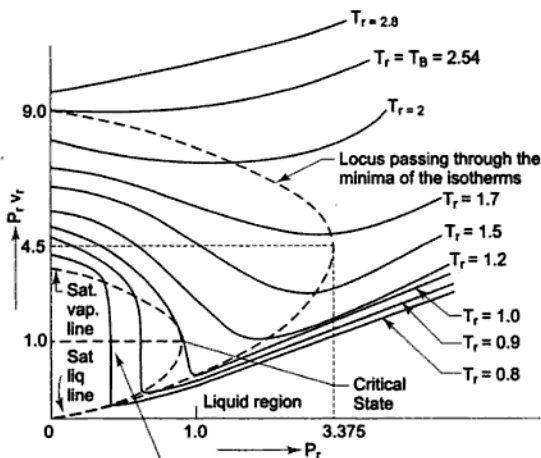

Fig. 10.11 Law of corresponding states in reduced coordinates

or

$$\frac{3(3v_r - 1)^2}{v_r^2} = 8T_r = \left[p_r + \frac{3}{v_r^2} \right] (3v_r - 1)$$

Simplifying

$$(p_r v_r)^2 - 9(p_r v_r) + 6p_r = 0$$

This is the equation of a parabola passing through the minima of the isotherms (Fig. 10.9).

When

$$\begin{aligned} p_r &= 0, \\ p_r v_r &= 0, 9 \end{aligned}$$

Again

$$p_r = \frac{9(p_r v_r) - (p_r v_r)^2}{6}$$

$$\frac{dp_r}{d(p_r v_r)} = 9 - 2(p_r v_r) = 0$$

∴

$$p_r v_r = 4.5$$

$$p_r = \frac{9 \times 4.5 \times (4.5)^2}{6} = 3.375$$

The parabola has the vertex at $p_r v_r = 4.5$ and $p_r = 3.375$, and it intersects the ordinate at 0 and 9.

Each isotherm up to that marked T_B has a minimum (Fig. 10.11). The T_B isotherm has an initial horizontal portion ($p_r v_r = \text{constant}$) so that Boyle's law is obeyed fairly accurately up to moderate pressures. Hence, the corresponding

temperature is called the *Boyle temperature* for that gas. The Boyle temperature T_B can be determined by making

$$\left[\frac{\partial(p_r v_r)}{\partial p_r} \right]_{T_r = T_B} = 0 \text{ when } p_r = 0$$

Above the Boyle temperature, the isotherms slope upward and show no minima.

As T_r is reduced below the critical (i.e. for $T_r < 1$), the gas becomes liquefied, and during phase transition isotherms are vertical. The minima of all these isotherms lie in the liquid zone.

Van der Waals equation of state can be expressed in the virial form as given below

$$\left(p + \frac{a}{v^2} \right) (v - b) = RT$$

$$\left(pv + \frac{a}{v} \right) \left(1 - \frac{b}{v} \right) = RT$$

$$\begin{aligned} \therefore pv + \frac{a}{v} &= RT \left(1 - \frac{b}{v} \right)^{-1} \\ &= RT \left[1 + \frac{b}{v} + \frac{b^2}{v^2} + \frac{b^3}{v^3} + \dots \right] \quad \left(\text{where } \frac{b}{v} < 1 \right) \end{aligned}$$

$$\therefore pv = RT \left[1 + \left(b - \frac{a}{RT} \right) \frac{1}{v} + \frac{b^2}{v^2} + \frac{b^3}{v^3} + \dots \right] \quad (10.94)$$

\therefore The second virial coefficient $B = b - a/RT$, the third virial coefficient $C = b^2$, etc.

From Eq. (10.85), on mass basis

$$pv = RT \left(1 + \frac{B}{RT} p + \frac{C - B^2}{RT^2} p^2 + \dots \right)$$

To determine Boyle temperature, T_B

$$\left[\frac{\partial(pv)}{\partial p} \right]_{p=0}^{T=C} = 0 = \frac{B}{RT}$$

$$\therefore B = 0$$

or $T_B = \frac{a}{bR}$, because $B = b - \frac{a}{RT}$

The point at which B is equal to zero gives the Boyle temperature. The second virial coefficient is the most important. Since $\left[\frac{\partial(pv)}{\partial p} \right]_{p=0} = B$, when B is known, the behaviour of the gas at moderate pressures is completely determined. The

terms which contain higher power (C/v^2 , D/v^3 , etc.) become significant only at very high pressures.

10.8 Other Equations of State

van der Waals equation is one of the oldest equations of state introduced in 1899, where the constants a and b are related to the critical state properties as found earlier,

$$a = 3p_c v_c^2 = \frac{27}{64} \frac{R^2 T_c^2}{p_c}, \quad b = \frac{1}{3} v_c = \frac{1}{8} \frac{RT_c}{p_c}$$

The Beattie-Bridgeman equation developed in 1928 is given in Eq. 10.79, which has five constants. It is essentially an empirical curve fit of data, and is reasonably accurate when values of specific volume are greater than v_c .

Benedict, Webb, and Rubin extended the Beattie-Bridgeman equation of state to cover a broader range of states as given below:

$$p = \frac{\bar{R}T}{v} + \left(B\bar{R}T - A - \frac{c}{T^2} \right) \frac{1}{\bar{v}^2} + \frac{(b\bar{R}T - a)}{\bar{v}^3} + \frac{a}{\bar{v}^6} \\ + \frac{c}{\bar{v}^3 T^2} \left(1 + \frac{\gamma}{\bar{v}^2} \right) \exp \left(-\frac{\gamma}{\bar{v}^2} \right)$$

It has eight constants and is quite successful in predicting the p - v - T behaviour of light hydrocarbons.

The Redlich-Kwong equation proposed in 1949 and given by Eq. 10.77 has the constants a and b in terms of critical properties as follows:

$$a = 0.4275 \frac{R^2 T_c^{2.5}}{p_c}, \quad b = 0.0867 \frac{RT_c}{p_c}$$

The values of the constants for the van der Waals, Redlich-Kwong and Benedict-Webb-Rubin equations of state are given in Table 10.1.1, while those for the Beattie-Bridgeman equation of state are given in Table 10.1.2. Apart from these, many other multi-constant equations of state have been proposed. With the advent of high speed computers, equations having 50 or more constants have been developed for representing the p - v - T behaviour of different substances.

10.9 Properties of Mixtures of Gases—Dalton's Law of Partial Pressures

Let us imagine a homogeneous mixture of inert ideal gases at a temperature T , a pressure p , and a volume V . Let us suppose there are n_1 moles of gas A_1 , n_2 moles of gas A_2 , ... and upto n_c moles of gas A_c (Fig. 10.12). Since there is no

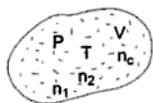

Fig. 10.12 Mixture of gases

Table 10.1.1 Constants for the van der Waals, Redlich-Kwong, and Benedict-Webb-Rubin Equations of State

1. van der Waals and Redlich-Kwong: Constants for pressure in bars, specific volume in m^3/kmol , and temperature in K

Substance	van der Waals		Redlich-Kwong	
	a $\text{bar} \left(\frac{\text{m}^3}{\text{kmol}} \right)^2$	b $\frac{\text{m}^3}{\text{kmol}}$	a $\text{bar} \left(\frac{\text{m}^3}{\text{kmol}} \right)^2 \text{K}^{1/2}$	b $\frac{\text{m}^3}{\text{kmol}}$
Air	1.368	0.0367	15.989	0.02541
Butane (C_4H_{10})	13.86	0.1162	289.55	0.08060
Carbon dioxide (CO_2)	3.647	0.0428	64.43	0.02963
Carbon monoxide (CO)	1.474	0.0395	17.22	0.02737
Methane (CH_4)	2.293	0.0428	32.11	0.02965
Nitrogen (N_2)	1.366	0.0386	15.53	0.02677
Oxygen (O_2)	1.369	0.0317	17.22	0.02197
Propane (C_3H_8)	9.349	0.0901	182.23	0.06242
Refrigerant 12	10.49	0.0971	208.59	0.06731
Sulfur dioxide (SO_2)	6.883	0.0569	144.80	0.03945
Water (H_2O)	5.531	0.0305	142.59	0.02111

Source: Calculated from critical data.

2. Benedict-Webb-Rubin: Constants for pressure in bars, specific volume in $\text{m}^3/\text{k mol}$, and temperature in K

Substance	a	A	b	B	c	C	α	γ
C_4H_{10}	1.9073	10.218	0.039998	0.12436	3.206×10^5	1.006×10^6	1.101×10^{-3}	0.0340
CO_2	0.1386	2.7737	0.007210	0.04991	1.512×10^4	1.404×10^5	8.47×10^{-5}	0.00539
CO	0.0371	1.3590	0.002632	0.05454	1.054×10^3	8.676×10^3	1.350×10^{-4}	0.0060
CH_4	0.0501	1.8796	0.003380	0.04260	2.579×10^3	2.287×10^4	1.244×10^{-4}	0.0060
N_2	0.0254	1.0676	0.002328	0.04074	7.381×10^2	8.166×10^1	1.272×10^{-4}	0.0053

Source: H.W. Cooper, and J.C. Goldfrank, Hydrocarbon Processing, 45 (12); 141 (1967).

Table 10.1.2

(a) The Beattie-Bridgeman equation of state is

$$P = \frac{R_u T}{\bar{v}^2} \left(1 - \frac{c}{\bar{v} T^2} \right) (\bar{v} + B) - \frac{A}{\bar{v}}, \text{ where } A = A_0 \left(1 - \frac{a}{\bar{v}} \right) \text{ and } B = B_0 \left(1 - \frac{b}{\bar{v}} \right)$$

When P is in kPa, \bar{v} is in $\text{m}^3/\text{k mol}$, T is in K, and $R_u = 8.314 \text{ kPa}\cdot\text{m}^3/(\text{kmol}\cdot\text{K})$, the five constants in the Beattie-Bridgeman equation are as follows:

Gas	A_0	a	B_0	b	c
Air	131.8441	0.01931	0.04611	-0.001101	4.34×10^4
Argon, Ar	130.7802	0.02328	0.03931	0.0	5.99×10^4
Carbon dioxide, CO_2	507.2836	0.07132	0.10476	0.07235	6.60×10^5
Helium, He	2.1886	0.05984	0.01400	0.0	40
Hydrogen, H_2	20.0117	-0.00506	0.02096	-0.04359	504
Nitrogen, N_2	136.2315	0.02617	0.05046	-0.00691	4.20×10^4
Oxygen, O_2	151.0857	0.02562	0.04624	0.004208	4.80×10^4

Source: Gordon J. Van Wylen and Richard E. Sonntag, Fundamentals of Classical Thermodynamics, English/SI Version, 3d ed., Wiley New York, 1986, p. 46. Table 3.3.

chemical reaction, the mixture is in a state of equilibrium with the equation of state

$$pV = (n_1 + n_2 + \dots + n_c) \bar{R}T$$

where

$$\bar{R} = 8.3143 \text{ kJ/kg mol K}$$

∴

$$p = \frac{n_1 \bar{R}T}{V} + \frac{n_2 \bar{R}T}{V} + \dots + \frac{n_c \bar{R}T}{V}$$

The expression $\frac{n_k \bar{R}T}{V}$ represents the pressure that the K th gas would exert if it occupied the volume V alone at temperature T . This is called the *partial pressure* of the K th gas and is denoted by p_K . Thus

$$p_1 = \frac{n_1 \bar{R}T}{V}, p_2 = \frac{n_2 \bar{R}T}{V}, \dots, p_c = \frac{n_c \bar{R}T}{V}$$

and

$$p = p_1 + p_2 + \dots + p_c \quad (10.95)$$

This is known as *Dalton's law of partial pressures* which states that the total pressure of a mixture of ideal gases is equal to the sum of the partial pressures.

Now

$$\begin{aligned} V &= (n_1 + n_2 + \dots + n_c) \frac{\bar{R}T}{p} \\ &= \sum n_K \cdot \frac{\bar{R}T}{p} \end{aligned}$$

and the partial pressure of the K th gas is

$$p_K = \frac{n_K \bar{R}T}{V}$$

Substituting the value of V

$$p_K = \frac{n_K \bar{R}T \cdot p}{\sum n_K \cdot \bar{R}T} = \frac{n_K}{\sum n_K} \cdot p$$

Now

$$\begin{aligned} \sum n_K &= n_1 + n_2 + \dots + n_c \\ &= \text{Total number of moles of gas} \end{aligned}$$

The ratio $\frac{n_K}{\sum n_K}$ is called the *mole fraction of the K th gas*, and is denoted by

x_K .

Thus

$$x_1 = \frac{n_1}{\sum n_K}, x_2 = \frac{n_2}{\sum n_K}, \dots, x_c = \frac{n_c}{\sum n_K}$$

and

$$p_1 = x_1 p, p_2 = x_2 p, \dots, p_c = x_c p$$

$$\text{or} \quad p_K = x_K \cdot p \quad (10.96)$$

$$\text{Also} \quad x_1 + x_2 + \dots + x_c = 1 \quad (10.97)$$

In a mixture of gases, if all but one mole fraction is determined, the last can be calculated from the above equation. Again, in terms of masses

$$p_1 V = m_1 R_1 T$$

$$p_2 V = m_2 R_2 T$$

.....

$$p_c V = m_c R_c T$$

Adding, and using Dalton's law

$$pV = (m_1 R_1 + m_2 R_2 + \dots + m_c R_c) T \quad (10.98)$$

$$\text{where} \quad p = p_1 + p_2 + \dots + p_c$$

For the gas mixture

$$pV = (m_1 + m_2 + \dots + m_c) R_m T \quad (10.99)$$

where R_m is the gas constant for the mixture. From Eqs (10.98) and (10.99)

$$R_m = \frac{m_1 R_1 + m_2 R_2 + \dots + m_c R_c}{m_1 + m_2 + \dots + m_c} \quad (10.100)$$

The gas constant of the mixture is thus the weighted mean, on a mass basis, of the gas constants of the components.

The total mass of gas mixture m is

$$m = m_1 + \dots + m_c$$

If μ denotes the *equivalent molecular weight* of the mixture having n total number of moles.

$$n\mu = n_1 \mu_1 + n_2 \mu_2 + \dots + n_c \mu_c$$

$$\therefore \quad \mu = x_1 \mu_1 + x_2 \mu_2 + \dots + x_c \mu_c$$

$$\text{or} \quad \mu = \sum x_K \mu_K \quad (10.101)$$

A quantity called the *partial volume* of a component of a mixture is the volume that the component alone would occupy at the pressure and temperature of the mixture. Designating the partial volumes by V_1, V_2 , etc.

$$pV_1 = m_1 R_1 T, pV_2 = m_2 R_2 T, \dots, pV_c = m_c R_c T$$

$$\text{or} \quad p(V_1 + V_2 + \dots + V_c) = (m_1 R_1 + m_2 R_2 + \dots + m_c R_c) T \quad (10.102)$$

From Eqs (10.98), (10.99) and (10.102)

$$V = V_1 + V_2 + \dots + V_c \quad (10.103)$$

The total volume is thus equal to the sum of the partial volumes.

The *specific volume of the mixture*, v , is given by

$$v = \frac{V}{m} = \frac{V}{m_1 + m_2 + \dots + m_c}$$

$$\text{or} \quad \frac{1}{v} = \frac{m_1 + m_2 + \dots + m_c}{V}$$

$$= \frac{m_1}{V} + \frac{m_2}{V} + \dots + \frac{m_c}{V}$$

or

$$\frac{1}{v} = \frac{1}{v_1} + \frac{1}{v_2} + \dots + \frac{1}{v_c} \quad (10.104)$$

where v_1, v_2, \dots denote specific volumes of the components, each component occupying the total volume.

Therefore, the density of the mixture $\rho = \rho_1 + \rho_2 + \dots + \rho_c$ (10.105)

10.10 Internal Energy, Enthalpy and Specific Heats of Gas Mixtures

When gases at equal pressures and temperatures are mixed adiabatically without work, as by inter-diffusion in a constant volume container, the first law requires that the internal energy of the gaseous system remains constant, and experiments show that the temperature remains constant. Hence the internal energy of a mixture of gases is equal to the sum of the internal energies of the individual components, each taken at the temperature and volume of the mixture (i.e. sum of the 'partial' internal energies). This is also true for any of the thermodynamic properties like H, C_v, C_p, S, F and G and is known as *Gibbs theorem*. Therefore, on a mass basis

$$mu_m = m_1u_1 + m_2u_2 + \dots + m_cu_c$$

$$u_m = \frac{m_1u_1 + m_2u_2 + \dots + m_cu_c}{m_1 + m_2 + \dots + m_c} \quad (10.106)$$

which is the average specific internal energy of the mixture.

Similarly, the total enthalpy of a gas mixture is the sum of the 'partial' enthalpies

$$mh_m = m_1h_1 + m_2h_2 + \dots + m_ch_c$$

and

$$h_m = \frac{m_1h_1 + m_2h_2 + \dots + m_ch_c}{m_1 + m_2 + \dots + m_c} \quad (10.107)$$

From the definitions of specific heats, it follows that

$$c_{vm} = \frac{m_1c_{v1} + m_2c_{v2} + \dots + m_cc_{vc}}{m_1 + m_2 + \dots + m_c} \quad (10.108)$$

and

$$c_{pm} = \frac{m_1c_{p1} + m_2c_{p2} + \dots + m_cc_{pc}}{m_1 + m_2 + \dots + m_c} \quad (10.109)$$

10.11 Entropy of Gas Mixtures

Gibbs theorem states that the total entropy of a mixture of gases is the sum of the partial entropies. The partial entropy of one of the gases of a mixture is the entropy

that the gas would have if it occupied the whole volume alone at the same temperature. Let us imagine a number of inert ideal gases separated from one another by suitable partitions, all the gases being at the same temperature T and pressure p . The total entropy (initial)

$$S_i = n_1 s_1 + n_2 s_2 + \dots + n_c s_c \\ = \sum n_K s_K$$

From property relation

$$T ds = dh - v dp = c_p dT - v dp$$

$$\therefore d\bar{s} = \bar{c}_p \frac{dT}{T} - \bar{R} \frac{dp}{p}$$

The entropy of 1 mole of the K th gas at T and p

$$\bar{s}_K = \int c_{pK} \frac{dT}{T} - \bar{R} \ln p + \bar{s}_{0K}$$

where s_{0K} is the constant of integration.

$$\therefore S_i = \bar{R} \sum n_K \left(\frac{1}{\bar{R}} \int \bar{c}_{pK} \frac{dT}{T} + \frac{\bar{s}_{0K}}{\bar{R}} - \ln p \right)$$

Let

$$\sigma_K = \frac{1}{\bar{R}} \int \bar{c}_{pK} \frac{dT}{T} + \frac{\bar{s}_{0K}}{\bar{R}}$$

then

$$S_i = \bar{R} \sum n_K (\sigma_K - \ln p) \quad (10.110)$$

After the partitions are removed, the gases diffuse into one another at the same temperature and pressure, and by Gibbs theorem, the entropy of the mixture, S_f , is the sum of the partial entropies, with each gas exerting its respective partial pressure. Thus

$$S_f = \bar{R} \sum n_K (\sigma_K - \ln p_K)$$

Since

$$p_K = x_K p$$

$$S_f = \bar{R} \sum n_K (\sigma_K - \ln x_K - \ln p) \quad (10.111)$$

A change in entropy due to the diffusion of any number of inert ideal gases is

$$S_f - S_i = -\bar{R} \sum n_K \ln x_K \quad (10.112)$$

or

$$S_f - S_i = -\bar{R} (n_1 \ln x_1 + n_2 \ln x_2 + \dots + n_c \ln x_c)$$

Since the mole fractions are less than unity, $(S_f - S_i)$ is always positive, conforming to the Second Law.

Again

$$S_f - S_i = -\bar{R} \left(n_1 \ln \frac{p_1}{p} + n_2 \ln \frac{p_2}{p} + \dots + n_c \ln \frac{p_c}{p} \right) \quad (10.113)$$

which indicates that each gas undergoes in the diffusion process a *free expansion* from total pressure p to the respective partial pressure at constant temperature.

Similarly, on a mass basis, the entropy change due to diffusion

$$S_f - S_i = -\sum m_K R_K \ln \frac{p_K}{p}$$

$$= -\left(m_1 R_1 \ln \frac{p_1}{p} + m_2 R_2 \ln \frac{p_2}{p} + \dots + m_c R_c \ln \frac{p_c}{p} \right)$$

10.12 Gibbs Function of a Mixture of Inert Ideal Gases

From the equations

$$d\bar{h} = \bar{c}_p dT$$

$$d\bar{s} = \bar{c}_p \frac{dT}{T} - \bar{R} \frac{dp}{p}$$

the enthalpy and entropy of 1 mole of an ideal gas at temperature T and pressure p are

$$\bar{h} = \bar{h}_0 + \int c_p dT$$

$$\bar{s} = \int \bar{c}_p \frac{dT}{T} + \bar{s}_0 - \bar{R} \ln p$$

Therefore, the molar Gibbs function

$$\bar{g} = \bar{h} - T\bar{s}$$

$$= \bar{h}_0 + \int \bar{c}_p dT - T \int \bar{c}_p \frac{dT}{T} - T\bar{s}_0 - \bar{R}T \ln p$$

Now $\int d(uv) = \int u dv + \int v du = uv$

Let $u = \frac{1}{T}, v = \int c_p dT$

Then $\frac{1}{T} \int c_p dT = \int \frac{1}{T} c_p dT + \int c_p dT \left(-\frac{1}{T^2} \right) dT$

$$= \int \frac{1}{T} c_p dT - \int \frac{c_p dT}{T^2}$$

$$\int c_p dT - T \int c_p \frac{dT}{T} = -T \int \frac{c_p dT}{T^2}$$

Therefore

$$\bar{g} = \bar{h}_0 - T \int \frac{\bar{c}_p dT}{T^2} dT - T\bar{s}_0 + \bar{R}T \ln p$$

$$= \bar{R}T \left(\frac{\bar{h}_0}{\bar{R}T} - \frac{1}{R} \int \frac{\bar{c}_p dT}{T^2} - \frac{\bar{s}_0}{R} + \ln p \right)$$

Let

$$\phi = \frac{\bar{h}_0}{\bar{R}T} - \frac{1}{R} \int \frac{\bar{c}_p dT}{T^2} - \frac{\bar{s}_0}{R} \quad (10.114)$$

Thus $\bar{g} = \bar{R}T(\phi + \ln p)$ (10.115)

where ϕ is a function of temperature only.

Let us consider a number of inert ideal gases separated from one another at the same T and p

$$\begin{aligned} G_i &= \sum n_K g_K \\ &= \bar{R}T \sum n_K (\phi_K + \ln p) \end{aligned}$$

After the partitions are removed, the gases will diffuse, and the partial Gibbs function of a particular gas is the value of G , if that gas occupies the same volume at the same temperature exerting a partial pressure p_K . Thus

$$\begin{aligned} G_f &= \bar{R}T \sum n_K (\phi_K + \ln p_K) \\ &= \bar{R}T \sum n_K (\phi_K + \ln p + \ln x_K) \end{aligned}$$

Therefore

$$G_f - G_i = \bar{R}T \sum n_K \ln x_K \quad (10.116)$$

Since $x_K < 1$, $(G_f - G_i)$ is negative because G decreases due to diffusion.

Gibbs function of a mixture of ideal gases at T and p is thus

$$G = \bar{R}T \sum n_K (\phi_K + \ln p + \ln x_K) \quad (10.117)$$

SOLVED EXAMPLES

Example 10.1 Two vessels, A and B , both containing nitrogen, are connected by a valve which is opened to allow the contents to mix and achieve an equilibrium temperature of 27°C . Before mixing the following information is known about the gases in the two vessels.

<i>Vessel A</i>	<i>Vessel B</i>
$p = 1.5 \text{ MPa}$	$p = 0.6 \text{ MPa}$
$t = 50^\circ\text{C}$	$t = 20^\circ\text{C}$
Contents = 0.5 kgmol	Contents = 2.5 kg

Calculate the final equilibrium pressure, and the amount of heat transferred to the surroundings. If the vessel had been perfectly insulated, calculate the final temperature and pressure which would have been reached. Take $\gamma = 1.4$.

Solution For the gas in vessel A (Fig. Ex. 10.1)

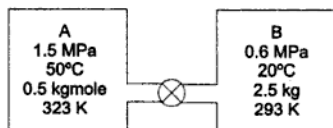

Fig. Ex. 10.1

$$P_A V_A = n_A \bar{R} T_A$$

where V_A is the volume of vessel A

$$1.5 \times 10^3 \times V_A = 0.5 \times 8.3143 \times 323$$

$$V_A = 0.895 \text{ m}^3$$

The mass of gas in vessel A

$$\begin{aligned} m_A &= n_A \mu_A \\ &= 0.5 \text{ kg mol} \times 28 \text{ kg/kgmol} \\ &= 14 \text{ kg} \end{aligned}$$

Characteristic gas constant R of nitrogen

$$R = \frac{8.3143}{28} = 0.297 \text{ kJ/kg K}$$

For the vessel B

$$p_B V_B = m_B R T_B$$

$$0.6 \times 10^3 \times V_B = 2.5 \times 0.297 \times 293$$

$$\therefore V_B = 0.363 \text{ m}^3$$

Total volume of A and B

$$\begin{aligned} V &= V_A + V_B = 0.895 + 0.363 \\ &= 1.258 \text{ m}^3 \end{aligned}$$

Total mass of gas

$$m = m_A + m_B = 14 + 2.5 = 16.5 \text{ kg}$$

Final temperature after mixing

$$T = 27 + 273 = 300 \text{ K}$$

For the final condition after mixing

$$pV = mRT$$

where p is the final equilibrium pressure

$$\therefore p \times 1.258 = 16.5 \times 0.297 \times 300$$

$$\begin{aligned} \therefore p &= \frac{16.5 \times 0.297 \times 300}{1.258} \\ &= 1168.6 \text{ kPa} \\ &= 1.168 \text{ MPa} \end{aligned}$$

$$c_v = \frac{R}{\gamma - 1} = \frac{0.297}{0.4}$$

$$= 0.743 \text{ kJ/kg K}$$

Since there is no work transfer, the amount of heat transfer

$$Q = \text{change of internal energy}$$

$$= U_2 - U_1$$

Measuring the internal energy above the datum of absolute zero (at $T = 0 \text{ K}$, $u = 0 \text{ kJ/kg}$)

Initial internal energy U_1 (before mixing)

$$= m_A c_v T_A + m_B c_v T_B$$

$$= (14 \times 323 + 2.5 \times 293) \times 0.743$$

$$= 3904.1 \text{ kJ}$$

Final internal energy U_2 (after mixing)

$$= mc_v T$$

$$= 16.5 \times 0.743 \times 300$$

$$= 3677.9 \text{ kJ}$$

$$\therefore Q = 3677.9 - 3904.1 = -226.2 \text{ kJ}$$

Ans.

If the vessels were insulated

$$U_1 = U_2$$

$$m_A c_v T_A + m_B c_v T_B = mc_v T$$

where T would have been the final temperature.

$$\therefore T = \frac{m_A T_A + m_B T_B}{m}$$

$$= \frac{14 \times 323 + 2.5 \times 293}{16.5} = 318.5 \text{ K}$$

$$\text{or } t = 45.5^\circ\text{C}$$

Ans.

The final pressure

$$p = \frac{mRT}{V} = \frac{16.5 \times 0.297 \times 318.5}{1.258}$$

$$= 1240.7 \text{ kPa}$$

$$= 1.24 \text{ MPa}$$

Example 10.2 A certain gas has $c_p = 1.968$ and $c_v = 1.507 \text{ kJ/kg K}$. Find its molecular weight and the gas constant.

A constant volume chamber of 0.3 m^3 capacity contains 2 kg of this gas at 5°C . Heat is transferred to the gas until the temperature is 100°C . Find the work done, the heat transferred, and the changes in internal energy, enthalpy and entropy.

Solution Gas constant,

$$R = c_p - c_v = 1.968 - 1.507 \\ = 0.461 \text{ kJ/kg K} \quad \text{Ans.}$$

Molecular weight,

$$\mu = \frac{\bar{R}}{R} = \frac{8.3143}{0.461} = 18.04 \text{ kg/kgmol} \quad \text{Ans.}$$

At constant volume

$$Q_{1-2} = mc_v (t_2 - t_1) \\ = 2 \times 1.507 (100 - 5) \\ = 286.33 \text{ kJ} \quad \text{Ans.}$$

Change in internal energy

$$W_{1-2} = \int_1^2 p dv = 0 \quad \text{Ans.}$$

$$U_2 - U_1 = Q_{1-2} = 286.33 \text{ kJ} \quad \text{Ans.}$$

Change in enthalpy

$$H_2 - H_1 = mc_p (t_2 - t_1) \\ = 2 \times 1.968 (100 - 5) = 373.92 \text{ kJ} \quad \text{Ans.}$$

Change in entropy

$$S_2 - S_1 = mc_v \ln \frac{T_2}{T_1} = 2 \times 1.507 \ln \frac{373}{278} \\ = 0.886 \text{ kJ/K} \quad \text{Ans.}$$

Example 10.3 (a) The specific heats of a gas are given by $c_p = a + kT$ and $c_v = b + kT$, where a , b , and k are constants and T is in K . Show that for an isentropic expansion of this gas

$$T^b \cdot v^{a-b} e^{kT} = \text{constant}$$

(b) 1.5 kg of this gas occupying a volume of 0.06 m^3 at 5.6 MPa expands isentropically until the temperature is 240°C . If $a = 0.946$, $b = 0.662$, and $k = 10^{-4}$, calculate the work done in the expansion.

Solution

$$(a) \quad c_p - c_v = a + kT - b - kT \\ = a - b = R$$

$$\text{Now} \quad ds = c_v \frac{dT}{T} + R \frac{dv}{v} \\ = (b + kT) \frac{dT}{T} + (a - b) \frac{dv}{v} = b \frac{dT}{T} + k dT + (a - b) \frac{dv}{v}$$

For an isentropic process

$$b \ln T + kT + (a - b) \ln v = \text{constant}$$

$$\therefore T^b \cdot v^{a-b} e^{kT} = \text{constant} \quad (\text{Q.E.D.})$$

$$(b) \quad R = a - b = 0.946 - 0.662 = 0.284 \text{ kJ/kg K}$$

$$T_2 = 240 + 273 = 513 \text{ K}$$

$$T_1 = \frac{p_1 V_1}{m R} = \frac{5.6 \times 10^3 \times 0.06}{1.5 \times 0.284} = 788.73 \text{ K} = 789 \text{ K}$$

$$T ds = dU + \delta W = 0$$

$$\begin{aligned} \therefore W_{1-2} &= \int_{T_1}^{-T_2} m c_v dT \\ &= 1.5 \int_{513}^{789} (0.662 + 0.0001T) dT \\ &= 1.5 [0.662 (789 - 513) + 10^{-4} \times 0.5 \{(789)^2 - (513)^2\}] \\ &= 1.5 (182.71 + 19.97) \\ &= 304 \text{ kJ} \end{aligned} \quad \text{Ans.}$$

Example 10.4 Show that for an ideal gas, the slope of the constant volume line on the T - s diagram is more than that of the constant pressure line.

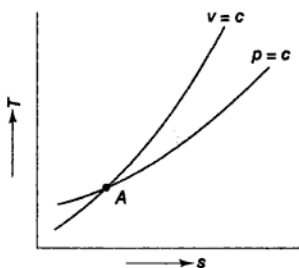

Fig. Ex. 10.4

Solution We have, for 1 kg of ideal gas

$$\begin{aligned} T ds &= du + p dv \\ &= c_v dT + p dv \end{aligned}$$

$$\therefore \left(\frac{\partial T}{\partial s} \right)_v = \frac{T}{c_v}$$

$$\text{Also} \quad \begin{aligned} T ds &= dh - v dp \\ &= c_p dT - v dp \end{aligned}$$

$$\therefore \left(\frac{\partial T}{\partial s} \right)_p = \frac{T}{c_p}$$

$$\text{Since} \quad c_p > c_v, \quad \frac{T}{c_v} > \frac{T}{c_p}$$

$$\therefore \left(\frac{\partial T}{\partial s} \right)_v > \left(\frac{\partial T}{\partial s} \right)_p$$

This is shown in Fig. Ex. 10.4. The slope of the constant volume line passing through point *A* is steeper than that of the constant pressure line passing through the same point. (Q.E.D.)

Example 10.5 0.5 kg of air is compressed reversibly and adiabatically from 80 kPa, 60°C to 0.4 MPa, and is then expanded at constant pressure to the original volume. Sketch these processes on the *p-v* and *T-s* planes. Compute the heat transfer and work transfer for the whole path.

Solution The processes have been shown on the *p-v* and *T-s* planes in Fig. Ex. 10.5. At state 1

$$p_1 V_1 = mRT_1$$

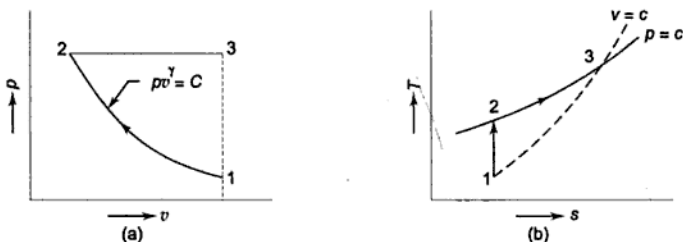

Fig. Ex. 10.5

$$\begin{aligned} \therefore V_1 &= \text{volume of air at state 1} \\ &= \frac{mRT_1}{p_1} = \frac{1 \times 0.287 \times 333}{2 \times 80} = 0.597 \text{ m}^3 \end{aligned}$$

Since the process 1-2 is reversible and adiabatic

$$\begin{aligned} \frac{T_2}{T_1} &= \left(\frac{p_2}{p_1} \right)^{(\gamma-1)/\gamma} \\ \therefore \frac{T_2}{T_1} &= \left(\frac{400}{80} \right)^{(1.4-1)/1.4} = (5)^{2/7} \\ \therefore T_2 &= 333 \times (5)^{2/7} = 527 \text{ K} \end{aligned}$$

For process 1-2, work done

$$\begin{aligned} W_{1-2} &= \frac{p_1 V_1 - p_2 V_2}{\gamma - 1} = \frac{mR(T_1 - T_2)}{\gamma - 1} \\ &= \frac{1/2 \times 0.287(333 - 527)}{0.4} \end{aligned}$$

$$= -69.6 \text{ kJ}$$

Again

$$p_1 v_1^\gamma = p_2 v_2^\gamma$$

$$\therefore \left(\frac{v_2}{v_1}\right)^\gamma = \frac{p_1}{p_2} = \frac{80}{400} = \frac{1}{5}$$

$$\therefore \frac{v_2}{v_1} = \left(\frac{1}{5}\right)^{1/1.4} = \frac{1}{3.162} = \frac{V_2}{V_1}$$

$$\therefore V_2 = \frac{0.597}{3.162} = 0.189 \text{ m}^3$$

For process 2-3, work done

$$\begin{aligned} W_{2-3} &= p_2 (V_1 - V_2) = 400 (0.597 - 0.189) \\ &= 163.2 \text{ kJ} \end{aligned}$$

 \therefore Total work transfer

$$\begin{aligned} W &= W_{1-2} + W_{2-3} \\ &= -69.6 + 163.2 = 93.6 \text{ kJ} \end{aligned}$$

Ans.

For states 2 and 3

$$\frac{p_2 V_2}{T_2} = \frac{p_3 V_3}{T_3}$$

$$\therefore T_3 = T_2 \cdot \frac{V_3}{V_2} = 527 \times 3.162 = 1667 \text{ K}$$

Total heat transfer

$$\begin{aligned} Q &= Q_{1-2} + Q_{2-3} = Q_{2-3} = mc_p (T_3 - T_2) \\ &= 1/2 \times 1.005 (1667 - 527) \\ &= 527.85 \text{ kJ} \end{aligned}$$

Ans.

Example 10.6 A mass of air is initially at 260°C and 700 kPa , and occupies 0.028 m^3 . The air is expanded at constant pressure to 0.084 m^3 . A polytropic process with $n = 1.50$ is then carried out, followed by a constant temperature process which completes a cycle. All the processes are reversible. (a) Sketch the cycle in the p - v and T - s planes. (b) Find the heat received and heat rejected in the cycle. (c) Find the efficiency of the cycle.

Solution (a) The cycle is sketched on the p - v and T - s planes in Fig. Ex. 10.6.

Given

$$\begin{aligned} p_1 &= 700 \text{ kPa}, T_1 = 260 + 273 = 533 \text{ K} = T_3 \\ V_1 &= 0.028 \text{ m}^3 \\ V_2 &= 0.084 \text{ m}^3 \end{aligned}$$

From the ideal gas equation of state

$$\begin{aligned} p_1 V_1 &= mRT_1 \\ m &= \frac{700 \times 0.028}{0.287 \times 533} = 0.128 \text{ kg} \end{aligned}$$

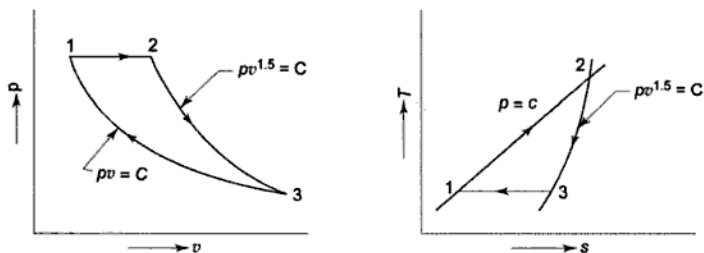

Fig. Ex. 10.6

$$\text{Now} \quad \frac{T_2}{T_1} = \frac{p_2 V_2}{p_1 V_1} = \frac{0.0084}{0.028} = 3$$

$$\therefore T_2 = 3 \times 533 = 1599 \text{ K}$$

$$\text{Again} \quad \frac{p_2}{p_3} = \left(\frac{T_2}{T_3} \right)^{n/(n-1)} = \left(\frac{1599}{533} \right)^{1.5/0.5} = (3)^3 = 27$$

Heat transfer in process 1-2

$$\begin{aligned} Q_{1-2} &= mc_p (T_2 - T_1) \\ &= 0.128 \times 1.005 (1599 - 533) \\ &= 137.13 \text{ kJ} \end{aligned}$$

Heat transfer in process 2-3

$$\begin{aligned} Q_{2-3} &= \Delta U + \int p dv \\ &= mc_v (T_3 - T_2) + \frac{mR(T_2 - T_3)}{n-1} \\ &= mc_v \frac{n-\gamma}{n-1} (T_3 - T_2) \\ &= 0.128 \times 0.718 \times \frac{1.5-1.4}{1.5-1} (533 - 1599) \\ &= 0.128 \times 0.718 \times \frac{0.1}{0.5} (-1066) \\ &= -19.59 \text{ kJ} \end{aligned}$$

For process 3-1

$$\delta Q = dU + \delta W = \delta W$$

$$\begin{aligned} \therefore Q_{3-1} &= W_{3-1} = \int_3^1 p dV = mRT_1 \ln \frac{V_1}{V_3} \\ &= mRT_1 \ln \frac{p_3}{p_1} = 0.128 \times 0.287 \times 533 \ln \left(\frac{1}{27} \right) \end{aligned}$$

$$\begin{aligned}
 &= -0.128 \times 0.287 \times 533 \times 3.2959 \\
 &= -64.53 \text{ kJ}
 \end{aligned}$$

(b) Heat received in the cycle

$$Q_1 = 137.13 \text{ kJ}$$

Heat rejected in the cycle

$$Q_2 = 19.59 + 64.53 = 84.12 \text{ kJ} \quad \text{Ans.}$$

(c) The efficiency of the cycle

$$\begin{aligned}
 \eta_{\text{cycle}} &= 1 - \frac{Q_2}{Q_1} = 1 - \frac{84.12}{137.13} = 1 - 0.61 \\
 &= 0.39, \text{ or } 39\% \quad \text{Ans.}
 \end{aligned}$$

Example 10.7 A mass of 0.25 kg of an ideal gas has a pressure of 300 kPa, a temperature of 80°C, and a volume of 0.07 m³. The gas undergoes an irreversible adiabatic process to a final pressure of 300 kPa and final volume of 0.10 m³, during which the work done on the gas is 25 kJ. Evaluate the c_p and c_v of the gas and the increase in entropy of the gas.

Solution From

$$\begin{aligned}
 p_1 V_1 &= mRT_1 \\
 R &= \frac{300 \times 0.07}{0.25 \times (273 + 80)} = 0.238 \text{ kJ/kg K}
 \end{aligned}$$

Final temperature

$$T_2 = \frac{p_2 V_2}{mR} = \frac{300 \times 0.1}{0.25 \times 0.238} = 505 \text{ K}$$

Now

$$\begin{aligned}
 Q &= (U_2 - U_1) + W = mc_v (T_2 - T_1) + W \\
 0 &= 0.25 c_v (505 - 353) - 25
 \end{aligned}$$

∴

$$c_v = \frac{25}{0.25 \times 152} = 0.658 \text{ kJ/kg K}$$

Now

$$\begin{aligned}
 c_p - c_v &= R \\
 c_p &= 0.658 + 0.238 = 0.896 \text{ kJ/kg K}
 \end{aligned}$$

Entropy change

$$\begin{aligned}
 S_2 - S_1 &= mc_v \ln \frac{p_2}{p_1} + mc_p \ln \frac{v_2}{v_1} \\
 &= mc_p \ln \frac{V_2}{V_1} = 0.25 \times 0.896 \ln \frac{0.10}{0.07} \\
 &= 0.224 \times 0.3569 = 0.08 \text{ kJ/kg K} \quad \text{Ans.}
 \end{aligned}$$

Example 10.8 A two-stage air compressor with perfect intercooling takes in air at 1 bar pressure and 27°C. The law of compression in both the stages is $pv^{1.3}$

= constant. The compressed air is delivered at 9 bar from the H.P. cylinder to an air receiver. Calculate, per kilogram of air, (a) the minimum work done and (b) the heat rejected to the intercooler.

Solution The minimum work required in a two-stage compressor is given by Eq. (10.65),

$$\begin{aligned} W_c &= \frac{2nRT_1}{n-1} \left[\left(\frac{p_2}{p_1} \right)^{(n-1)/n} - 1 \right] \\ &= \frac{2 \times 1.3 \times 0.287 \times 300}{0.3} [(3)^{0.3/1.3} - 1] \\ &= 26 \times 0.287 \times 100 \times 0.287 = 214.16 \text{ kJ/kg} \quad \text{Ans. (a)} \end{aligned}$$

$$p_2 = \sqrt{p_1 p_3} = \sqrt{1 \times 9} = 3 \text{ bar}$$

$$\begin{aligned} \frac{T_2}{T_1} &= \left(\frac{p_2}{p_1} \right)^{n-1/n} = 3^{0.3/1.3} = 1.28856 \\ T_2 &= 386.56 \text{ K} \end{aligned}$$

Heat rejected to the intercooler

$$\begin{aligned} &= 1.005 (386.56 - 300) \\ &= 86.99 \text{ kJ/kg} \quad \text{Ans. (b)} \end{aligned}$$

Example 10.9 A single-acting two-stage air compressor deals with $4 \text{ m}^3/\text{min}$ of air at 1.013 bar and 15°C with a speed of 250 rpm. The delivery pressure is 80 bar. Assuming complete intercooling, find the minimum power required by the compressor and the bore and stroke of the compressor. Assume a pistong speed of 3 m/s, mechanical efficiency of 75% and volumetric efficiency of 80% per stage. Assume the polytropic index of compression in both the stages to be $n = 1.25$ and neglect clearance.

Solution

$$p_2 = \sqrt{p_1 p_4} = \sqrt{1.013 \times 80} = 9 \text{ bar}$$

Minimum power required by the compressor

$$\begin{aligned} \dot{W} &= \frac{2n}{n-1} p_1 \dot{V}_1 \left[\left(\frac{p_2}{p_1} \right)^{n-1/n} - 1 \right] \times \frac{1}{\eta_{\text{mech}}} \\ &= \frac{2 \times 1.25}{0.25} \times \frac{1.013 \times 100}{0.75} \times \frac{4}{60} \left[\left(\frac{9}{1.013} \right)^{0.25/1.25} - 1 \right] \\ &= \frac{1013 \times 4}{45} \times 0.548 = 49.34 \text{ kW} \quad \text{Ans.} \end{aligned}$$

If L be the stroke length of the piston,

$$2L \frac{N}{60} = 3 \text{ m/s}$$

$$L = \frac{90 \times 100}{250} = 36 \text{ cm} \quad \text{Ans.}$$

Effective LP swept volume = $4/250 = 0.016 \text{ m}^3$

$$\frac{\pi}{4}(D_{LP})^2 \times 0.36 \times \eta_{vol} = 0.016$$

$$\therefore D_{LP} = \sqrt{\frac{0.016 \times 4}{\pi \times 0.36 \times 0.8}} = 0.266 \text{ m} = 26.6 \text{ cm} \quad \text{Ans.}$$

$$\frac{p_1 V_1}{T_1} = \frac{p_3 V_3}{T_3}$$

$$\therefore \frac{V_3}{V_1} = \frac{p_1}{p_3}$$

$$\frac{\frac{\pi}{4} D_{HP}^2 L}{\frac{\pi}{4} D_{LP}^2 L} = \frac{1.013}{9}$$

$$D_{HP} = 0.266 \sqrt{\frac{1.013}{9}} = 0.0892 \text{ m} = 8.92 \text{ cm} \quad \text{Ans.}$$

Example 10.10 A single cylinder reciprocating compressor has a bore of 120 mm and a stroke of 150 mm, and is driven at a speed of 1200 rpm. It is compressing CO_2 from a pressure of 120 kPa and a temperature of 25°C to a temperature of 215°C . Assuming polytropic compression with $n = 1.3$, no clearance and a volumetric efficiency of 100%, calculate (a) the pressure ratio, (b) indicated power, (c) shaft power, with a mechanical efficiency of 80%, (d) mass flow rate.

If a second stage of equal pressure ratio were added, calculate (e) the overall pressure ratio and (f) bore of the second stage, if the same stroke was maintained.

Solution (a) With respect to Fig. Ex. 10.10,

$$p_2/p_1 = (T_2/T_1)^{n/(n-1)} = \left(\frac{488}{298}\right)^{1.3/0.3} = 8.48 \quad \text{Ans. (a)}$$

$$(b) \quad V_1 = V_s = \frac{\pi}{4}(0.12)^2 \times 0.15 = 0.0017 \text{ m}^3$$

$$W = \frac{n}{n-1} p_1 V_1 \left[(p_2/p_1)^{\frac{n-1}{n}} - 1 \right]$$

$$= \frac{1.3}{0.3} \times 120 \times 10^3 \times 0.0017 [(8.48)^{0.3/1.3} - 1] = 563.6 \text{ J}$$

$$\text{Indicated power} = 563.6 \times \frac{1200}{60} = 11.27 \text{ kW} \quad \text{Ans. (b)}$$

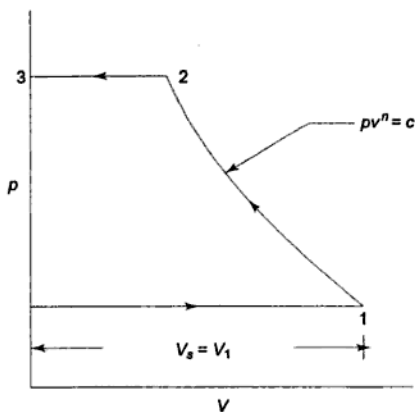

Fig. Ex. 10.10

(c) Shaft power = $\frac{11.27}{0.8} = 14.1 \text{ kW}$ Ans. (c)

(d) Volumetric flow rate = $0.0017 \times \frac{1200}{60} = 0.034 \text{ m}^3/\text{s}$

$$\dot{m} = \frac{p_1 \dot{V}_1}{RT_1} = \frac{120 \times 10^3 \times 0.034}{(8314/44) \times 298} = 0.0725 \text{ kg/s}$$
 Ans. (d)

(e) If a second stage were added with the same pressure ratio, the overall pressure ratio would be

$$\left(\frac{p_2}{p_1}\right)_{\text{overall}} = \left(\frac{p_2}{p_1}\right)^n = (8.48)^2 = 71.9$$
 Ans. (e)

(f) Volumetric delivery per cycle is V_2 .

Since

$$p_1 V_1^n = p_2 V_2^n,$$

$$V_2 = \left(\frac{p_1}{p_2}\right)^{1/n} \times V_1 = \left[\frac{1}{8.48}\right]^{1/1.3} \times 0.0017 = 0.00033 \text{ m}^3.$$

If the second stage would have a swept volume of 0.00033 m^3 , with the same stroke,

$$\frac{\pi}{4} d^2 \times 0.15 = 0.00033$$

$$d = 53 \text{ mm}$$

Ans. (f)

Example 10.11 A mixture of ideal gases consists of 3 kg of nitrogen and 5 kg of carbon dioxide at a pressure of 300 kPa and a temperature of 20°C . Find (a) the

mole fraction of each constituent, (b) the equivalent molecular weight of the mixture, (c) the equivalent gas constant of the mixture, (d) the partial pressures and the partial volumes, (e) the volume and density of the mixture, and (f) the c_p and c_v of the mixture.

If the mixture is heated at constant volume to 40°C, find the changes in internal energy, enthalpy and entropy of the mixture. Find the changes in internal energy, enthalpy and entropy of the mixture if the heating is done at constant pressure. Take γ for CO₂ and N₂ to be 1.286 and 1.4 respectively.

Solution

(a) Since mole fraction $x_i = \frac{n_i}{\sum n_i}$

$$x_{N_2} = \frac{3}{\frac{3}{28} + \frac{5}{44}} = 0.485$$

$$x_{CO_2} = \frac{5}{\frac{3}{28} + \frac{5}{44}} = 0.515 \quad \text{Ans.}$$

(b) Equivalent molecular weight of the mixture

$$\begin{aligned} M &= x_1\mu_1 + x_2\mu_2 \\ &= 0.485 \times 28 + 0.515 \times 44 \\ &= 36.25 \text{ kg/kg mol} \end{aligned} \quad \text{Ans.}$$

(c) Total mass,

$$m = m_{N_2} + m_{CO_2} = 3 + 5 = 8 \text{ kg}$$

Equivalent gas constant of the mixture

$$\begin{aligned} R &= \frac{m_{N_2} R_{N_2} + m_{CO_2} R_{CO_2}}{m} \\ &= \frac{3 \times \frac{8.3143}{28} + 5 \times \frac{8.3143}{44}}{8} = \frac{0.89 + 0.94}{8} \\ &= 0.229 \text{ kJ/kg K} \end{aligned} \quad \text{Ans.}$$

(d)

$$\begin{aligned} p_{N_2} &= x_{N_2} \cdot p = 0.485 \times 300 = 145.5 \text{ kPa} \\ p_{CO_2} &= x_{CO_2} \cdot p = 0.515 \times 300 = 154.5 \text{ kPa} \end{aligned}$$

$$V_{N_2} = \frac{m_{N_2} R_{N_2} T}{p} = \frac{3 \times \frac{8.3143}{28} \times 293}{300} = 0.87 \text{ m}^3$$

$$V_{CO_2} = \frac{m_{CO_2} R_{CO_2} T}{p} = \frac{5 \times \frac{8.3143}{44} \times 293}{300} = 0.923 \text{ m}^3 \quad \text{Ans.}$$

(e) Total volume of the mixture

$$V = \frac{mRT}{p} = \frac{m_{N_2} R_{N_2} T}{p_{N_2}} = \frac{m_{CO_2} R_{CO_2} T}{p_{CO_2}}$$

$$\therefore V = \frac{8 \times 0.229 \times 293}{300} = 1.79 \text{ m}^3$$

Density of the mixture

$$\begin{aligned} \rho &= \rho_{N_2} + \rho_{CO_2} = \frac{m}{V} = \frac{8}{1.79} \\ &= 4.46 \text{ kg/m}^3 \end{aligned}$$

Ans.

(f) $c_{pN_2} - c_{vN_2} = R_{N_2}$

$$\begin{aligned} \therefore c_{vN_2} &= \frac{R_{N_2}}{\gamma - 1} = \frac{8.3143}{28 \times (1.4 - 1)} \\ &= 0.742 \text{ kJ/kg K} \end{aligned}$$

$$\begin{aligned} \therefore c_{pN_2} &= 1.4 \times 0.742 \\ &= 1.039 \text{ kJ/kg K} \end{aligned}$$

For CO_2 ,

$$\gamma = 1.286$$

$$\therefore c_{vCO_2} = \frac{R_{CO_2}}{\gamma - 1} = \frac{8.3143}{44 \times 0.286} = 0.661 \text{ kJ/kg K}$$

$$c_{pCO_2} = 1.286 \times 0.661 = 0.85 \text{ kJ/kg K}$$

For the mixture

$$\begin{aligned} c_p &= \frac{m_{N_2} c_{pN_2} + m_{CO_2} c_{pCO_2}}{m_{N_2} + m_{CO_2}} \\ &= \frac{3}{8} \times 1.039 + \frac{5}{8} \times 0.85 \\ &= 0.92 \text{ kJ/kg K} \end{aligned}$$

$$\begin{aligned} c_v &= \frac{m_{N_2} c_{vN_2} + m_{CO_2} c_{vCO_2}}{m} \\ &= \frac{3}{8} \times 0.742 + \frac{5}{8} \times 0.661 = 0.69 \text{ kJ/kg K} \end{aligned} \quad \text{Ans.}$$

If the mixture is heated at constant volume

$$\begin{aligned} U_2 - U_1 &= mc_v (T_2 - T_1) \\ &= 8 \times 0.69 \times (40 - 20) \\ &= 110.4 \text{ kJ} \end{aligned}$$

$$\begin{aligned} H_2 - H_1 &= mc_p (T_2 - T_1) \\ &= 8 \times 0.92 \times 20 = 147.2 \text{ kJ} \end{aligned}$$

$$\begin{aligned} S_2 - S_1 &= mc_v \ln \frac{T_2}{T_1} + mR \ln \frac{V_2}{V_1} \\ &= mc_v \ln \frac{T_2}{T_1} = 8 \times 0.69 \times \ln \frac{313}{293} \end{aligned}$$

$$= 0.368 \text{ kJ/kg K} \quad \text{Ans.}$$

If the mixture is heated at constant pressure, ΔU and ΔH will remain the same. The change in entropy will be

$$\begin{aligned} S_2 - S_1 &= mc_p \ln \frac{T_2}{T_1} - mR \ln \frac{p_2}{p_1} \\ &= mc_p \ln \frac{T_2}{T_1} = 8 \times 0.92 \ln \frac{313}{293} \\ &= 0.49 \text{ kJ/kg K} \quad \text{Ans.} \end{aligned}$$

Example 10.12 Find the increase in entropy when 2 kg of oxygen at 60°C are mixed with 6 kg of nitrogen at the same temperature. The initial pressure of each constituent is 103 kPa and is the same as that of the mixture.

Solution

$$x_{\text{O}_2} = \frac{p_{\text{O}_2}}{p} = \frac{\frac{2}{32}}{\frac{2}{32} + \frac{6}{28}} = 0.225$$

$$x_{\text{N}_2} = \frac{p_{\text{N}_2}}{p} = 0.775$$

Entropy increase due to diffusion

$$\begin{aligned} \Delta S &= -m_{\text{O}_2} R_{\text{O}_2} \ln \frac{p_{\text{O}_2}}{p} - m_{\text{N}_2} R_{\text{N}_2} \ln \frac{p_{\text{N}_2}}{p} \\ &= -2 \left(\frac{8.3143}{32} \right) \ln 0.225 - 6 \left(\frac{8.3143}{28} \right) \ln 0.775 \\ &= 1.2314 \text{ kJ/kg K} \quad \text{Ans.} \end{aligned}$$

Example 10.13 The gas neon has a molecular weight of 20.183 and its critical temperature, pressure and volume are 44.5 K, 2.73 MPa and $0.0416 \text{ m}^3/\text{kgmol}$. Reading from a compressibility chart for a reduced pressure of 2 and a reduced temperature of 1.3, the compressibility factor Z is 0.7. What are the corresponding specific volume, pressure, temperature, and reduced volume?

Solution At $p_r = 2$ and $T_r = 1.3$ from chart (Fig. Ex. 10.13), $z = 0.7$

$$p = 2 \times 2.73 = 5.46 \text{ MPa} \quad \text{Ans.}$$

$$\frac{T}{T_c} = 1.3$$

$$T = 1.3 \times 44.5 = 57.85 \text{ K} \quad \text{Ans.}$$

$$pv = ZRT$$

$$\begin{aligned} \therefore v &= \frac{0.7 \times 8.3143 \times 57.85}{20.183 \times 5.46 \times 10^3} \\ &= 3.05 \times 10^{-3} \text{ m}^3/\text{kg} \end{aligned}$$

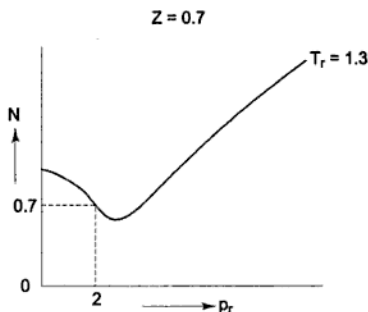

Fig. Ex. 10.13

$$\therefore v_r = \frac{v}{v_c} = \frac{3.05 \times 10^{-3} \times 20.183}{4.16 \times 10^{-2}} = 1.48$$

Ans.

Example 10.14 For the Berthelot equation of state

$$p = \frac{RT}{v-b} - \frac{a}{Tv^2}$$

 show that (a) $\lim_{\substack{p \rightarrow 0 \\ T \rightarrow \infty}} (RT - pv) = 0$

$$(b) \lim_{T \rightarrow \infty} \frac{v}{T} = \frac{R}{p}$$

$$(c) \text{Boyle temperature, } T_B = \sqrt{\frac{a}{bR}},$$

$$(d) \text{Critical properties } p_c = \frac{1}{12b} \sqrt{\frac{2aR}{3b}}, v_c = 3b, T_c = \sqrt{\frac{8a}{27bR}},$$

(e) Law of corresponding states

$$\left(p_r + \frac{3}{T_r \cdot v_r^2} \right) (3v_r - 1) = 8T_r$$

Solution

$$(a) p = \frac{RT}{v-b} - \frac{a}{Tv^2}$$

$$\therefore RT = \left(p + \frac{a}{Tv^2} \right) (v-b)$$

$$\text{or} \quad \frac{RT}{p} = v + \frac{a}{pvT} - b - \frac{ab}{pv^2T}$$

$$\therefore RT - pv = \frac{a}{vT} - bp - \frac{ab}{v^2T}$$

$$\therefore \lim_{\substack{p \rightarrow 0 \\ T \rightarrow \infty}} (RT - pv) = 0 \quad \text{Proved (a)}$$

$$\text{(b) Now} \quad v = \frac{RT}{p} - \frac{a}{pvT} + b + \frac{ab}{pv^2T}$$

$$\therefore \frac{v}{T} = \frac{R}{p} - \frac{a}{pvT^2} + \frac{b}{T} + \frac{ab}{pv^2T^2}$$

$$\therefore \lim_{T \rightarrow \infty} \frac{v}{T} = \frac{R}{p} \quad \text{Proved (b)}$$

$$\text{(c)} \quad pv = RT - \frac{a}{vT} + bp + \frac{ab}{v^2T}$$

The last three terms of the equation are very small, except at very high pressures and small volume. Hence substituting $v = RT/p$

$$pv = RT - \frac{ap}{RT^2} + bp + \frac{abp^2}{R^2T^3}$$

$$\therefore \left[\frac{\partial(pv)}{\partial p} \right]_T = -\frac{a}{RT^2} + b + \frac{2abp}{R^2T^3} = 0$$

when $p = 0$, $T = T_B$, the Boyle temperature

$$\therefore \frac{a}{RT_B^2} = b$$

$$\text{or} \quad T_B = \sqrt{\frac{a}{bR}} \quad \text{Proved (d)}$$

$$\text{(d)} \quad p = \frac{RT}{v-b} - \frac{a}{Tv^2}$$

$$\left(\frac{\partial p}{\partial v} \right)_{T=T_c} = -\frac{RT_c}{(v_c-b)^2} + \frac{2a}{T_c \cdot v_c^3} = 0$$

$$\left(\frac{\partial^2 p}{\partial v^2} \right)_{T=T_c} = \frac{2RT_c}{(v_c-b)^3} - \frac{6a}{T_c \cdot v_c^4} = 0$$

$$\left(p_c + \frac{a}{T_c v_c^2} \right) (v_c - b) = RT_c$$

By solving the three equations, as was done in the case of van der Waals equation of state in Article 10.7

$$p_c = \frac{1}{12b} \sqrt{\frac{2aR}{3b}}, v_c = 3b, \text{ and } T_c = \sqrt{\frac{8a}{27bR}} \quad \text{Proved (d)}$$

(e) Solving the above three equations

$$a = \frac{8v_c^3 p_c^2}{R} = 3p_c \cdot v_c^2 \cdot T_c$$

$$b = \frac{v_c}{3}, R = \frac{8}{3} \frac{p_c v_c}{T_c} \quad (\text{so that } Z_c = 3/8)$$

Substituting in the equation

$$\left(p + \frac{a}{Tv^2}\right)(v - b) = RT$$

$$\left(p + \frac{3p_c v_c^2 T_c}{Tv^2}\right)\left(v - \frac{v_c}{3}\right) = \frac{8p_c v_c}{3T_c} \cdot T$$

$$\left(p_r + \frac{3}{T_r v_r^2}\right)(3v_r - 1) = 8T_r$$

This is the law of corresponding states.

Proved (e)

REVIEW QUESTIONS

- 10.1 What is a mole?
- 10.2 What is Avogadro's law?
- 10.3 What is an equation of state?
- 10.4 What is the fundamental property of gases with respect to the product pv ?
- 10.5 What is universal gas constant?
- 10.6 Define an ideal gas.
- 10.7 What is the characteristic gas constant?
- 10.8 What is Boltzmann constant?
- 10.9 Why do the specific heats of an ideal gas depend only on the atomic structure of the gas?
- 10.10 Show that for an ideal gas the internal energy depends only on its temperature.
- 10.11 Show that the enthalpy of an ideal gas is a function of temperature only.
- 10.12 Why is there no temperature change when an ideal gas is throttled?
- 10.13 Show that for an ideal gas, $c_p - c_v = R$.
- 10.14 Derive the equations used for computing the entropy change of an ideal gas.
- 10.15 Show that for a reversible adiabatic process executed by an ideal gas, the following relations hold good: (i) $pv^\gamma = \text{constant}$, (ii) $Tv^{\gamma-1} = \text{constant}$, and (iii) $Tp^{(1-\gamma)/\gamma} = \text{constant}$.
- 10.16 Express the changes in internal energy and enthalpy of an ideal gas in a reversible adiabatic process in terms of the pressure ratio.
- 10.17 Derive the expression of work transfer for an ideal gas in a reversible isothermal process.
- 10.18 What is a polytropic process? What are the relations among p , v and T of an ideal gas in a polytropic process?

- 10.19 Show that the entropy change between states 1 and 2 in a polytropic process, $p v^n = \text{constant}$, is given by the following relations:

$$(i) \quad s_2 - s_1 = \frac{n - \gamma}{(\gamma - 1)(n - 1)} R \ln \frac{T_2}{T_1}$$

$$(ii) \quad s_2 - s_1 = \frac{n - \gamma}{n(\gamma - 1)} R \ln \frac{p_2}{p_1}$$

$$(iii) \quad s_2 - s_1 = -\frac{n - \gamma}{\gamma - 1} R \ln \frac{v_2}{v_1}$$

- 10.20 What are the expressions of work transfer for an ideal gas in a polytropic process, if the gas is: (i) a closed system, and (ii) a steady flow system?
- 10.21 Derive the expression of heat transfer for an ideal gas in a polytropic process. What is the polytropic specific heat? What would be the direction of heat transfer if (a) $n > \gamma$, and (b) $n < \gamma$?

10.22 Why is the external work supplied to a compressor equal to $-\int_{p_1}^{p_2} v dp$?

- 10.23 Why does isothermal compression need minimum work and adiabatic compression maximum work?
- 10.24 What is the advantage of staging the compression process?
- 10.25 What is meant by perfect intercooling?
- 10.26 Show that the optimum intermediate pressure of a two-stage reciprocating compressor for minimum work is the geometric mean of the suction and discharge pressures.
- 10.27 Explain how the use of intermediate pressure for minimum work results in equal pressure ratios in the two stages of compression, equal discharge temperatures, and equal work for the two stages.
- 10.28 What is the isothermal efficiency of a compressor?
- 10.29 Define volumetric efficiency of a compressor.
- 10.30 Why does the volumetric efficiency of a compressor decrease: (a) as the clearance increases for the given pressure ratio, (b) as the pressure ratio increases for the given clearance?
- 10.31 Write down the van der Waals equation of state. How does it differ from the ideal gas equation of state. What is force of cohesion? What is co-volume?
- 10.32 What are the two-constant equations of state?
- 10.33 Give the virial expansions for $p v$ in terms of p and v .
- 10.34 What are virial coefficients? When do they become zero?
- 10.35 What is the compressibility factor?
- 10.36 What are reduced properties?
- 10.37 What is the generalized compressibility chart?
- 10.38 What is the law of corresponding states?
- 10.39 Express the van der Waals constants in terms of critical properties.
- 10.40 Draw the diagram representing the law of corresponding states in reduced coordinates indicating the isotherms and the liquid and vapour phases.
- 10.41 Define Boyle temperature? How is it computed?
- 10.42 State Dalton's law of partial pressures.

- 10.43 How is the partial pressure in a gas mixture related to the mole fraction?
10.44 How are the characteristic gas constant and the molecular weight of a gas mixture computed?
10.45 What is Gibb's theorem?
10.46 Show that in a diffusion process a gas undergoes a free expansion from the total pressure to the relevant partial pressure.
10.47 Show that in a diffusion process at constant temperature the entropy increases and the Gibbs function decreases.

PROBLEMS

- 10.1 What is the mass of air contained in a room $6\text{ m} \times 9\text{ m} \times 4\text{ m}$ if the pressure is 101.325 kPa and the temperature is 25°C ?
Ans. 256 kg
- 10.2 The usual cooking gas (mostly methane) cylinder is about 25 cm in diameter and 80 cm in height. It is charged to 12 MPa at room temperature (27°C).
(a) Assuming the ideal gas law, find the mass of gas filled in the cylinder.
(b) Explain how the actual cylinder contains nearly 15 kg of gas. (c) If the cylinder is to be protected against excessive pressure by means of a fusible plug, at what temperature should the plug melt to limit the maximum pressure to 15 MPa ?
- 10.3 A certain gas has $c_p = 0.913$ and $c_v = 0.653\text{ kJ/kg K}$. Find the molecular weight and the gas constant R of the gas.
- 10.4 From an experimental determination the specific heat ratio for acetylene (C_2H_2) is found to 1.26 . Find the two specific heats.
- 10.5 Find the molal specific heats of monatomic, diatomic, and polyatomic gases, if their specific heat ratios are respectively $5/3$, $7/5$ and $4/3$.
- 10.6 A supply of natural gas is required on a site 800 m above storage level. The gas at -150°C , 1.1 bar from storage is pumped steadily to a point on the site where its pressure is 1.2 bar , its temperature 15°C , and its flow rate $1000\text{ m}^3/\text{hr}$. If the work transfer to the gas at the pump is 15 kW , find the heat transfer to the gas between the two points. Neglect the change in K.E. and assume that the gas has the properties of methane (CH_4) which may be treated as an ideal gas having $\gamma = 1.33$ ($g = 9.75\text{ m/s}^2$).
Ans. 63.9 kW
- 10.7 A constant volume chamber of 0.3 m^3 capacity contains 1 kg of air at 5°C . Heat is transferred to the air until the temperature is 100°C . Find the work done, the heat transferred, and the changes in internal energy, enthalpy and entropy.
- 10.8 One kg of air in a closed system, initially at 5°C and occupying 0.3 m^3 volume, undergoes a constant pressure heating process to 100°C . There is no work other than $p\,dV$ work. Find (a) the work done during the process, (b) the heat transferred, and (c) the entropy change of the gas.
- 10.9 0.1 m^3 of hydrogen initially at 1.2 MPa , 200°C undergoes a reversible isothermal expansion to 0.1 MPa . Find (a) the work done during the process, (b) the heat transferred, and (c) the entropy change of the gas.
- 10.10 Air in a closed stationary system expands in a reversible adiabatic process from 0.5 MPa , 15°C to 0.2 MPa . Find the final temperature, and per kg of air, the change in enthalpy, the heat transferred, and the work done.

- 10.11 If the above process occurs in an open steady from system, find the final temperature, and per kg of air, the change in internal energy, the heat transferred, and the shaft work. Neglect velocity and elevation changes.
- 10.12 The indicator diagram for a certain water-cooled cyclinder and piston air compressor shows that during compression $pv^{1.3} = \text{constant}$. The compression starts at 100 kPa, 25°C and ends at 600 kPa. If the process is reversible, how much heat is transferred per kg of air?
- 10.13 An ideal gas of molecular weight 30 and $\gamma = 1.3$ occupies a volume of 1.5 m³ at 100 kPa and 77°C. The gas is compressed according to the law $pv^{1.25} = \text{constant}$ to a pressure of 3 MPa. Calculate the volume and temperature at the end of compression and heating, work done, heat transferred, and the total change of entropy.
- 10.14 Calculate the change of entropy when 1 kg of air changes from a temperature of 330 K and a volume of 0.15 m³ to a temperature of 550 K and a volume of 0.6 m³. If the air expands according to the law, $pv^n = \text{constant}$, between the same end states, calculate the heat given to, or extracted from, the air during the expansion, and show that it is approximately equal to the change of entropy multiplied by the mean absolute temperature.
- 10.15 0.5 kg of air, initially at 25°C, is heated reversibly at constant pressure until the volume is doubled, and is then heated reversibly at constant volume until the pressure is doubled. For the total path, find the work transfer, the heat transfer, and the change of entropy.
- 10.16 An ideal gas cycle of three processes uses Argon (Mol. wt. 40) as a working substance. Process 1–2 is a reversible adiabatic expansion from 0.014 m³, 700 kPa, 280°C to 0.056 m³. Process 2–3 is a reversible isothermal process. Process 3–1 is a constant pressure process in which heat transfer is zero. Sketch the cycle in the p - v and T - s planes, and find (a) the work transfer in process 1–2, (b) the work transfer in process 2–3, and (c) the net work of the cycle. Take $\gamma = 1.67$.
- Ans.* (a) 8.85 kJ (b) 8.96 kJ (c) 5.82 kJ
- 10.17 A gas occupies 0.024 m³ at 700 kPa and 95°C. It is expanded in the non-flow process according to the law $pv^{1.2} = \text{constant}$ to a pressure of 70 kPa after which it is heated at constant pressure back to its original temperature. Sketch the process on the p - v and T - s diagrams, and calculate for the whole process the work done, the heat transferred, and the change of entropy. Take $C_p = 1.047$ and $c_v = 0.775$ kJ/kg K for the gas.
- 10.18 0.5 kg of air at 600 kPa receives an addition of heat at constant volume so that its temperature rises from 110°C to 650°C. It then expands in a cyclinder polytropically to its original temperature and the index of expansion is 1.32. Finally, it is compressed isothermally to its original volume. Calculate (a) the change of entropy during each of the three stages, (b) the pressures at the end of constant volume heat addition and at the end of expansion. Sketch the processes on the p - v and T - s diagrams.
- 10.19, 0.5 kg of helium and 0.5 kg of nitrogen are mixed at 20°C and at a total pressure of 100 kPa. Find (a) the volume of the mixture, (b) the partial volumes of the components, (c) the partial pressures of the components, (d) the mole fractions of the components, (e) the specific heats c_p and c_v of the mixture, and (f) the gas constant of the mixture.

Ans. (a) 3.481 m³ (b) 3.045, 0.436 m³ (c) 87.5, 12.5 kPa
(d) 0.875, 0.125 (e) 3.11, 1.921 kJ/k (f) 1.189 kJ/kgK.

- 10.20 A gaseous mixture consists of 1 kg of oxygen and 2 kg of nitrogen at a pressure of 150 kPa and a temperature of 20°C. Determine the changes in internal energy, enthalpy and entropy of the mixture when the mixture is heated to a temperature of 100°C (a) at constant volume, and (b) at constant pressure.
- 10.21 A closed rigid cylinder is divided by a diaphragm into two equal compartments, each of volume 0.1 m³. Each compartment contains air at a temperature of 20°C. The pressure in one compartment is 2.5 MPa and in the other compartment is 1 MPa. The diaphragm is ruptured so that the air in both the compartments mixes to bring the pressure to a uniform value throughout the cylinder which is insulated. Find the net change of entropy for the mixing process.
- 10.22 A vessel is divided into three compartments (a), (b), and (c) by two partitions. Part (a) contains oxygen and has a volume of 0.1 m³, (b) has a volume of 0.2 m³ and contains nitrogen, while (c) is 0.05 m³ and holds CO₂. All three parts are at a pressure of 2 bar and a temperature of 13°C. When the partitions are removed and the gases mix, determine the change of entropy of each constituent, the final pressure in the vessel and the partial pressure of each gas. The vessel may be taken as being completely isolated from its surroundings.
- Ans.* 0.0875, 0.0783, 0.0680 kJ/K; 2 bar; 0.5714, 1.1329, 0.2857 bar.
- 10.23 A Carnot cycle uses 1 kg of air as the working fluid. The maximum and minimum temperatures of the cycle are 600 K and 300 K. The maximum pressure of the cycle is 1 MPa and the volume of the gas doubles during the isothermal heating process. Show by calculation of net work and heat supplied that the efficiency is the maximum possible for the given maximum and minimum temperatures.
- 10.24 An ideal gas cycle consists of three reversible processes in the following sequence: (a) constant volume pressure rise, (b) isentropic expansion to r times the initial volume, and (c) constant pressure decrease in volume. Sketch the cycle on the p - v and T - s diagrams. Show that the efficiency of the cycle is

$$\eta_{\text{cycle}} = \frac{r^\gamma - 1 - \gamma(r - 1)}{r^\gamma - 1}$$

Evaluate the cycle efficiency when $\gamma = \frac{4}{3}$ and $r = 8$.

Ans. ($\eta = 0.378$)

- 10.25 Using the Dieterici equation of state

$$p = \frac{RT}{v - b} \cdot \exp\left(-\frac{a}{RTv}\right)$$

(a) show that

$$p_c = \frac{a}{4e^2 b^2} \quad v_c = 2b, \quad T_c = \frac{a}{4Rb}$$

(b) expand in the form

$$pv = RT \left(1 + \frac{B}{v} + \frac{C}{v^2} + \dots \right)$$

(c) show that

$$T_B = \frac{a}{bR}$$

- 10.26 The number of moles, the pressures, and the temperatures of gases a , b , and c are given as follows

Gas	m (kg mol)	p (kPa)	t ($^{\circ}\text{C}$)
N_2	1	350	100
CO	3	420	200
O_2	2	700	300

If the containers are connected, allowing the gases to mix freely, find (a) the pressure and temperature of the resulting mixture at equilibrium, and (b) the change of entropy of each constituent and that of the mixture.

- 10.27 Calculate the volume of 2.5 kg moles of steam at 236.4 atm. and 776.76 K with the help of compressibility factor versus reduced pressure graph. At this volume and the given pressure, what would the temperature be in K, if steam behaved like a van der Waals gas?

The critical pressure, volume, and temperature of steam are 218.2 atm, $57 \text{ cm}^3/\text{kg}$ mole, and 647.3 K respectively.

- 10.28 Two vessels, A and B , each of volume 3 m^3 may be connected together by a tube of negligible volume. Vessel A contains air at 7 bar, 95°C while B contains air at 3.5 bar, 205°C . Find the change of entropy when A is connected to B . Assume the mixing to be complete and adiabatic.

Ans. (0.975 kJ/kg K)

- 10.29 An ideal gas at temperature T_1 is heated at constant pressure to T_2 and then expanded reversibly, according to the law $pv^n = \text{constant}$, until the temperature is once again T_1 . What is the required value of n , if the changes of entropy during the separate processes are equal?

$$\text{Ans. } \left(n = \frac{2\gamma}{\gamma + 1} \right)$$

- 10.30 A certain mass of sulphur dioxide (SO_2) is contained in a vessel of 0.142 m^3 capacity, at a pressure and temperature of 23.1 bar and 18°C respectively. A valve is opened momentarily and the pressure falls immediately to 6.9 bar. Sometime later the temperature is again 18°C and the pressure is observed to be 9.1 bar. Estimate the value of specific heat ratio.

Ans. 1.29

- 10.31 A gaseous mixture contains 21% by volume of nitrogen, 50% by volume of hydrogen, and 29% by volume of carbon-dioxide. Calculate the molecular weight of the mixture, the characteristic gas constant R for the mixture and the value of the reversible adiabatic index γ . (At 10°C , the c_p values of nitrogen, hydrogen, and carbon dioxide are 1.039, 14.235, and 0.828 kJ/kg K respectively.)

A cylinder contains 0.085 m^3 of the mixture at 1 bar and 10°C . The gas undergoes a reversible non-flow process during which its volume is reduced to one-fifth of its original value. If the law of compression is $pv^{1.2} = \text{constant}$, determine the work and heat transfers in magnitude and sense and the change in entropy.

Ans. 19.64 kg/kg mol, 0.423 kJ/kg K, 1.365, -16 kJ, -7.24 kJ, -0.31 kJ/kg K

- 10.32 Two moles of an ideal gas at temperature T and pressure p are contained in a compartment. In an adjacent compartment is one mole of an ideal gas at temperature $2T$ and pressure p . The gases mix adiabatically but do not react chemically when a partition separating the compartments is withdrawn. Show that the entropy increase due to the mixing process is given by

$$R \left(\ln \frac{27}{4} + \frac{\gamma}{\gamma-1} \ln \frac{32}{27} \right)$$

provided that the gases are different and that the ratio of specific heat γ is the same for both gases and remains constant.

What would the entropy change be if the mixing gases were of the same species?

- 10.33 n_1 moles of an ideal gas at pressure p_1 and temperature T are in one compartment of an insulated container. In an adjoining compartment, separated by a partition, are n_2 moles of an ideal gas at pressure p_2 and temperature T . When the partition is removed, calculate (a) the final pressure of the mixture, (b) the entropy change when the gases are identical, and (c) the entropy change when the gases are different. Prove that the entropy change in (c) is the same as that produced by two independent free expansions.
- 10.34 Assume that 20 kg of steam are required at a pressure of 600 bar and a temperature of 750°C in order to conduct a particular experiment. A 140-litre heavy duty tank is available for storage. Predict if this is an adequate storage capacity using:
- the ideal gas theory,
 - the compressibility factor chart,
 - the van der Waals equation with $a = 5.454$ (litre)² atm/(gmol)², $b = 0.03042$ litres/gmol for steam,
 - the Mollier chart
 - the steam tables.

Estimate the error in each.

Ans. (a) 157.75 l, (b) 132.51 l, (c) 124.94 l (e) 137.29 l

- 10.35 Estimate the pressure of 5 kg of CO₂ gas which occupies a volume of 0.70 m³ at 75°C, using the Beattie-Bridgeman equation of state. Compare this result with the value obtained using the generalized compressibility chart. Which is more accurate and why?
- For CO₂ with units of atm, litres/g mol and K, $A_0 = 5.0065$, $a = 0.07132$, $B_0 = 0.10476$, $b = 0.07235$, $C \times 10^{-4} = 66.0$.
- 10.36 Measurements of pressure and temperature at various stages in an adiabatic air turbine show that the states of air lie on the line $pv^{1.25} = \text{constant}$. If kinetic and gravitational potential energy are neglected, prove that the shaft work per kg as a function of pressure is given by the following relation

$$W = 3.5 p_1 v_1 \left[1 - \left(\frac{p_2}{p_1} \right)^{1/5} \right]$$

Take γ for air as 1.4.

- 10.37 Air flows steadily into a compressor at a temperature of 17°C and a pressure of 1.05 bar and leaves at a temperature of 247°C and a pressure of 6.3 bar. There is no heat transfer to or from the air as it flows through the compressor; changes in elevation and velocity are negligible. Evaluate the external work done per kg of air, assuming air as an ideal gas for which $R = 0.287$ kJ/kg K and $\gamma = 1.4$. Evaluate the minimum external work required to compress the air adiabatically from the same initial state to the same final pressure and the isentropic efficiency of the compressor.

Ans. - 225 kJ/kg, - 190 kJ/kg, 84.4%

- 10.38 A slow-speed reciprocating air compressor with a water jacket for cooling approximates a quasi-static compression process following a path $pv^{1.3} = \text{const}$. If air enters at a temperature of 20°C and a pressure of 1 bar, and is compressed to 6 bar at a rate of 1000 kg/h, determine the discharge temperature of air, the power required and the heat transferred per kg.
Ans. 443 K, 51.82 kW, 36 kJ/kg
- 10.39 A single-acting two-stage reciprocating air compressor with complete intercooling delivers 6 kg/min at 15 bar pressure. Assume an intake condition of 1 bar and 15°C and that the compression and expansion processes are polytropic with $n = 1.3$. Calculate: (a) the power required, (b) the isothermal efficiency.
Ans. (a) 26.15 kW (b) 85.6%
- 10.40 A two-stage air compressor receives $0.238 \text{ m}^3/\text{s}$ of air at 1 bar and 27°C and discharges it at 10 bar. The polytropic index of compression is 1.35. Determine (a) the minimum power necessary for compression, (b) the power needed for single-stage compression to the same pressure, (c) the maximum temperature for (a) and (b), and (d) the heat removed in the intercooler.
Ans. (a) 63.8 kW, (b) 74.9 kW, (c) 404.2 K, 544.9 K, (d) 28.9 kW
- 10.41 A mass of an ideal gas exists initially at a pressure of 200 kPa, temperature 300 K, and specific volume $0.5 \text{ m}^3/\text{kg}$. The value of γ is 1.4. (a) Determine the specific heats of the gas. (b) What is the change in entropy when the gas is expanded to pressure 100 kPa according to the law $pv^{1.3} = \text{const}$? (c) What will be the entropy change if the path is $pv^{1.5} = \text{const}$. (by the application of a cooling jacket during the process)? (d) What is the inference you can draw from this example?
Ans. (a) 1.166, 0.833 kJ/kg K, (b) 0.044 kJ/kg K (c) -0.039 kJ/kg K
 (d) Entropy increases when $n < \gamma$ and decreases when $n > \gamma$
- 10.42 (a) A closed system of 2 kg of air initially at pressure 5 atm and temperature 227°C , expands reversibly to pressure 2 atm following the law $pv^{1.25} = \text{const}$. Assuming air as an ideal gas, determine the work done and the heat transferred.
Ans. 193 kJ, 72 kJ
- (b) If the system does the same expansion in a steady flow process, what is the work done by the system?
Ans. 241 kJ
- 10.43 Air contained in a cylinder fitted with a piston is compressed reversibly according to the law $pv^{1.25} = \text{const}$. The mass of air in the cylinder is 0.1 kg. The initial pressure is 100 kPa and the initial temperature 20°C . The final volume is 1/8 of the initial volume. Determine the work and the heat transfer.
Ans. -22.9 kJ , -8.7 kJ
- 10.44 Air is contained in a cylinder fitted with a frictionless piston. Initially the cylinder contains 0.5 m^3 of air at 1.5 bar, 20°C . The air is then compressed reversibly according to the law $pv^n = \text{constant}$ until the final pressure is 6 bar, at which point the temperature is 120°C . Determine: (a) the polytropic index n , (b) the final volume of air, (c) the work done on the air and the heat transfer, and (d) the net change in entropy
Ans. (a) 1.2685, (b) 0.1676 m^3 (c) -95.3 kJ , -31.5 kJ , (d) 0.0153 kJ/K
- 10.45 The specific heat at constant pressure for air is given by
 $c_p = 0.9169 + 2.577 \times 10^{-4} T - 3.974 \times 10^{-8} T^2 \text{ kJ/kg K}$

Determine the change in internal energy and that in entropy of air when it undergoes a change of state from 1 atm and 298 K to a temperature of 2000 K at the same pressure.

Ans. 1470.4 kJ/kg, 2.1065 kJ/kg K

- 10.46 A closed system allows nitrogen to expand reversibly from a volume of 0.25 m^3 to 0.75 m^3 along the path $pv^{1.32} = \text{const}$. The original pressure of the gas is 250 kPa and its initial temperature is 100°C . (a) Draw the p - v and T - s diagrams. (b) What are the final temperature and the final pressure of the gas? (c) How much work is done and how much heat is transferred? (d) What is the entropy change of nitrogen?

Ans. (b) 262.44 K, 58.63 kPa, (c) 57.89 kJ, 11.4 kJ, (d) 0.0362 kJ/K

- 10.47 Methane has a specific heat at constant pressure given by $c_p = 17.66 + 0.06188 T$ kJ/kg mol K when 1 kg of methane is heated at constant volume from 27 to 500°C . If the initial pressure of the gas is 1 atm, calculate the final pressure, the heat transfer, the work done and the change in entropy.

Ans. 2.577 atm, 1258.5 kJ/kg, 0, 2.3838 kJ/kg K

- 10.48 Air is compressed reversibly according to the law $pv^{1.25} = \text{const}$. from an initial pressure of 1 bar and volume of 0.9 m^3 to a final volume of 0.6 m^3 . Determine the final pressure and the change of entropy per kg of air.

Ans. 1.66 bar, -0.0436 kJ/kg K

- 10.49 In a heat engine cycle, air is isothermally compressed. Heat is then added at constant pressure, after which the air expands isentropically to its original state. Draw the cycle on p - v and T - s coordinates. Show that the cycle efficiency can be expressed in the following form

$$\eta = 1 - \frac{(\gamma - 1) \ln r}{\gamma[r^{\gamma-1/\gamma} - 1]}$$

where r is the pressure ratio, p_2/p_1 . Determine the pressure ratio and the cycle efficiency if the initial temperature is 27°C and the maximum temperature is 327°C .

Ans. 13.4, 32.4%

- 10.50 What is the minimum amount of work required to separate 1 mole of air at 27°C and 1 atm pressure (assumed composed of $1/5 \text{ O}_2$ and $4/5 \text{ N}_2$) into oxygen and nitrogen each at 27°C and 1 atm pressure?

Ans. 1250 J

- 10.51 A closed adiabatic cylinder of volume 1 m^3 is divided by a partition into two compartments 1 and 2. Compartment 1 has a volume of 0.6 m^3 and contains methane at 0.4 MPa, 40°C , while compartment 2 has a volume of 0.4 m^3 and contains propane at 0.4 MPa, 40°C . The partition is removed and the gases are allowed to mix. (a) When the equilibrium state is reached, find the entropy change of the universe. (b) What are the molecular weight and the specific heat ratio of the mixture?

The mixture is now compressed reversibly and adiabatically to 1.2 MPa. Compute (c) the final temperature of the mixture, (d) the work required per unit mass, and (e) the specific entropy change for each gas. Take c_p of methane and propane as 35.72 and 74.56 kJ/kg mol K respectively.

Ans. (a) 0.8609 kJ/K (b) 27.2, 1.193 (c) 100.9°C (d) 396 kJ (e) 0.255 kJ/kg K

- 10.52 An ideal gas cycle consists of the following reversible processes: (i) isentropic compression, (ii) constant volume heat addition, (iii) isentropic expansion, and (iv) constant pressure heat rejection. Show that the efficiency of this cycle is given by

$$\eta = 1 - \frac{1}{r_k^{\gamma-1}} \left[\frac{\gamma(a^{1/\gamma} - 1)}{a - 1} \right]$$

where r_k is the compression ratio and a is the ratio of pressures after and before heat addition.

An engine operating on the above cycle with a compression ratio of 6 starts the compression with air at 1 bar, 300 K. If the ratio of pressures after and before heat addition is 2.5, calculate the efficiency and the m.e.p. of the cycle. Take $\gamma = 1.4$ and $c_v = 0.718$ kJ/kg K.

Ans. 0.579, 2.5322 bar

- 10.53 The relation between u , p and v for many gases is of the form $u = a + bpv$ where a and b are constants. Show that for a reversible adiabatic process, $pv^\gamma = \text{constant}$, where $\gamma = (b + 1)/b$.

- 10.54 (a) Show that the slope of a reversible adiabatic process on p - v coordinates is

$$\frac{dp}{dv} = -\frac{1}{k} \frac{c_p}{c_v} \quad \text{where } k = -\frac{1}{v} \left(\frac{\partial v}{\partial p} \right)_T$$

(b) Hence, show that for an ideal gas, $pv^\gamma = \text{constant}$, for a reversible adiabatic process.

- 10.55 A certain gas obeys the Clausius equation of state $p(v - b) = RT$ and has its internal energy given by $u = c_v T$. Show that the equation for a reversible adiabatic process is $p(v - b)^\gamma = \text{constant}$, where $\gamma = c_p/c_v$.

- 10.56 (a) Two curves, one representing a reversible adiabatic process undergone by an ideal gas and the other an isothermal process by the same gas, intersect at the same point on the p - v diagram. Show that the ratio of the slope of the adiabatic curve to the slope of the isothermal curve is equal to γ . (b) Determine the ratio of work done during a reversible adiabatic process to the work done during an isothermal process for a gas having $\gamma = 1.6$. Both processes have a pressure ratio of 6.

- 10.57 Two containers p and q with rigid walls contain two different monatomic gases with masses m_p and m_q , gas constants R_p and R_q , and initial temperatures T_p and T_q respectively, are brought in contact with each other and allowed to exchange energy until equilibrium is achieved. Determine: (a) the final temperature of the two gases and (b) the change of entropy due to this energy exchange.

- 10.58 The pressure of a certain gas (photon gas) is a function of temperature only and is related to the energy and volume by $p(T) = (1/3)(U/V)$. A system consisting of this gas confined by a cylinder and a piston undergoes a Carnot cycle between two pressures p_1 and p_2 . (a) Find expressions for work and heat of reversible isothermal and adiabatic processes. (b) Plot the Carnot cycle on p - v and T - s diagrams. (c) Determine the efficiency of the cycle in terms of pressures. (d) What is the functional relation between pressure and temperature?

- 10.59 The gravimetric analysis of dry air is approximately: oxygen = 23% nitrogen = 77%. Calculate: (a) the volumetric analysis, (b) the gas constant, (c) the molecular weight, (d) the respective partial pressures, (e) the specific volume at

1 atm, 15°C, and (f) How much oxygen must be added to 2.3 kg air to produce a mixture which is 50% oxygen by volume?

Ans. (a) 21% O₂, 79% N₂, (b) 0.288 kJ/kg K, (d) 21 kPa for O₂,
(e) 0.84 m³/kg, (f) 1.47 kg

- 10.60 A vessel of volume $2V$ is divided into two equal compartments. These are filled with the same ideal gas, the temperature and pressure on one side of the partition being (p_1, T_1) and on the other (p_2, T_2) . Show that if the gases on the two sides are allowed to mix slowly with no heat entering, the final pressure and temperature will be given by

$$p = \frac{p_1 + p_2}{2}, \quad T = \frac{T_1 T_2 (p_1 + p_2)}{p_1 T_2 + p_2 T_1}$$

Further, show that the entropy gain is

$$\Delta S = V \left[\left(\frac{c_p}{R} \right) \left\{ \frac{p_1}{T_2} \ln \frac{T}{T_1} + \frac{p_2}{T_2} \ln \frac{T}{T_2} \right\} - \frac{p_1}{T_1} \ln \frac{p}{p_1} - \frac{p_2}{T_2} \ln \frac{p}{p_2} \right]$$

- 10.61 A single-acting air compressor has a cylinder of bore 15 cm and the piston stroke is 25 cm. The crank speed is 600 rpm. Air taken from the atmosphere (1 atm, 27°C) is delivered at 11 bar. Assuming polytropic compression $p v^{1.25} = \text{const.}$, find the power required to drive the compressor, when its mechanical efficiency is 80%. The compressor has a clearance volume which is 1/20th of the stroke volume. How long will it take to deliver 1 m³ of air at the compressor outlet conditions. Find the volumetric efficiency of the compressor.

Ans. 12.25 kW, 3.55 min, 72%

- 10.62 A multistage air compressor compresses air from 1 bar to 40 bar. The maximum temperature in any stage is not to exceed 400 K. (a) If the law of compression for all the stages is $p v^{1.3} = \text{const.}$, and the initial temperature is 300 K, find the number of stages for the minimum power input. (b) Find the intermediate pressures for optimum compression as well as the power needed. (c) What is the heat transfer in each of the intercooler?

Ans. (a) 3 (b) 3.48 bar, 12.1 bar, 373.1 kJ/kg (c) 100.5 kJ/kg

- 10.63 An ideal gas with a constant volume of $c_p = 29.6$ J/gmol-K is made to undergo a cycle consisting of the following reversible processes in a closed system:
Process 1-2: The gas expands adiabatically from 5 MPa, 550 K to 1 Mpa;
Process 2-3: The gas is heated at constant volume until 550 K; Process 3-1: The gas is compressed isothermally back to its initial condition.
Calculate the work, the heat and the change of entropy of the gas for each of the three processes. Draw the p - v and T - s diagrams.

$$\begin{aligned} \text{Ans. } W_{1-2} &= 4260 \text{ J/gmol}, Q_{1-2} = 0, \Delta s_{1-2} = 0, \\ W_{2-3} &= 0, Q_{2-3} = 4260 \text{ J/gmol}, \Delta s_{2-3} = 9.62 \\ &\text{J/gmol-K}, W_{3-1} = -5290 \text{ J/mol} = Q_{3-1}, \\ \Delta s_{3-1} &= -9.62 \text{ J/gmol-K}, W_{\text{net}} - Q_{\text{net}} = -1030 \end{aligned}$$

$$\text{J/gmol}, \oint dS = 0$$

- 10.64 Air in a closed system expands reversibly and adiabatically from 3 MPa, 200°C to two times its initial volume, and then cools at constant volume until the pressure drops to 0.8 MPa. Calculate the work done and heat transferred per kg of air. Use $c_p = 1.017$ and $c_v = 0.728$ kJ/kgK.

Ans. 82.7 kJ/kg, -78.1 kJ/kg

- 10.65 A vessel is divided into three compartments (a), (b) and (c) by two partitions. Part (a) contains hydrogen and has a volume of 0.1 m^3 , part (b) contains nitrogen and has a volume of 0.2 m^3 and part (c) contains carbon dioxide and has a volume of 0.05 m^3 . All the three parts are at a pressure of 2 bar and a temperature of 13°C . The partitions are removed and the gases are allowed to mix. Determine (a) the molecular weight of the mixture, (b) the characteristic gas constant for the mixture, (c) the partial pressures of each gas, (d) the reversible adiabatic index γ , and (e) the entropy change due to diffusion. The specific heats of hydrogen, nitrogen and carbon dioxide are 14.235, 1.039 and 0.828 kJ/kgK respectively.

The above gas mixture is then reversibly compressed to a pressure of 6 bar according to the law $pv^{1.2} = \text{constant}$, (f) Determine the work and heat interactions in magnitude and sense, and (g) the change in entropy.

$$\text{Ans. (a) } 22.8582 \text{ (b) } 0.3637 \text{ kJ/kgK (c) } p_{\text{H}_2} = 0.5714, p_{\text{N}_2} = 1.1428, \\ p_{\text{CO}_2} = 0.2858 \text{ bar (d) } 1.384 \text{ (e) } 0.3476 \text{ kJ/kgK (f) } -70.455 \text{ kJ,} \\ -33.772 \text{ kJ (g) } -0.1063 \text{ kJ/K.}$$

- 10.66 A four cylinder single-stage air compressor has a bore of 200 mm and a stroke of 300 mm and runs at 400 rpm. At a working pressure of 721.3 kPa it delivers 3.1 m^3 of air per min at 270°C . Calculate (a) the mass flow rate, (b) the free air delivery (FAD) (c) effective swept volume, (d) volumetric efficiency. Take the inlet condition as that of the free air at 101.3 kPa, 21°C .

$$\text{Ans. (a) } 0.239 \text{ kg/s (b) } 0.199 \text{ m}^3/\text{s (c) } 0.299 \text{ m}^3, \text{ (d) } 79.2\%$$

- 10.67 A single stage reciprocating air compressor has a swept volume of 2000 cm^3 and runs at 800 rpm. It operates on a pressure ratio of 8, with a clearance of 5% of the swept volume. Assume NTP room conditions, and at inlet, and polytropic compression and expansion with $n = 1.25$. Calculate (a) the indicated power, (b) volumetric efficiency, (c) mass flow rate, (d) the free air delivery FAD, (e) isothermal efficiency, (f) actual power needed to drive the compressor, if the mechanical efficiency is 0.85.

$$\text{Ans. (a) } 5.47 \text{ kW (b) } 78.6\% \text{ (c) } 1.54 \text{ kg/min (d) } 1.26 \text{ m}^3/\text{min,} \\ \text{(e) } 80.7\%, \text{ (f) } 6.44 \text{ kW}$$

- 10.68 A two-stage single-acting reciprocating compressor takes in air at the rate of $0.2 \text{ m}^3/\text{s}$. Intake pressure and temperature are 0.1 MPa and 16°C respectively. The air is compressed to a final pressure of 0.7 MPa. The intermediate pressure is ideal, and intercooling is perfect. The compression index is 1.25 and the compressor runs at 10 rps. Neglecting clearance, determine (a) the intermediate pressure, (b) the total volume of each cylinder, (c) the power required to drive the compressor, (d) the rate of heat absorption in the intercooler.

$$\text{Ans. (a) } 0.264 \text{ MPa (b) } 0.0076 \text{ m}^3 \text{ h.p. and } 0.02 \text{ m}^3 \text{ l.p cylinder} \\ \text{(c) } 42.8 \text{ kW (d) } 14.95 \text{ kW}$$

- 10.69 A 3-stage single-acting air compressor running in an atmosphere at 1.013 bar and 15°C has a free air delivery of $2.83 \text{ m}^3/\text{min}$. The suction pressure and temperature are 0.98 bar and 32°C respectively. The delivery pressure is to be 72 bar. Calculate the indicated power required, assuming complete intercooling, $n = 1.3$ and that the compressor is designed for minimum work. What will be the heat loss to the intercoolers?

$$\text{Ans. } 25.568 \text{ kW, } 13.78 \text{ kW}$$

- 10.70 Predict the pressure of nitrogen gas at $T = 175 \text{ K}$ and $v = 0.00375 \text{ m}^3/\text{kg}$ on the basis of (a) the ideal gas equation of state, (b) the van der Waals equation of state, (c) the Beattie-Bridgeman equation of state and (d) the Benedict-Webb-Rubin equation of state. Compare the values obtained with the experimentally determined value of 10,000 kPa.

Ans. (a) 13,860 kPa (b) 9468 kPa (c) 10,110 kPa (d) 10,000 kPa

- 10.71 The pressure in an automobile tyre depends on the temperature of the air in the tyre. When the air temperature is 25°C , the pressure gauge reads 210 kPa. If the volume of the tyre is 0.025 m^3 , determine the pressure rise in the tyre when the air temperature in the tyre rises to 50°C . Also find the amount of air that must be bled off to restore pressure to its original value at this temperature. Take atmospheric pressure as 100 kPa.

- 10.72 Two tanks are connected by a valve. One tank contains 2 kg of CO gas at 77°C and 0.7 bar. The other tank holds 8 kg of the same gas at 27°C and 1.2 bar. The valve is opened and the gases are allowed to mix while receiving energy by heat transfer from the surroundings. The final equilibrium temperature is 42°C . Using the ideal gas model, determine (a) the final equilibrium pressure, (b) the heat transfer for the process.

Ans. (a) 1.05 bar (b) 37.25 kJ

11

Thermodynamic Relations, Equilibrium and Third Law

11.1 Some Mathematical Theorems

Theorem 1 If a relation exists among the variables x , y , and z , then z may be expressed as a function of x and y , or

$$dz = \left(\frac{\partial z}{\partial x} \right)_y dx + \left(\frac{\partial z}{\partial y} \right)_x dy$$

If $\left(\frac{\partial z}{\partial x} \right)_y = M$, and $\left(\frac{\partial z}{\partial y} \right)_x = N$

then $dz = M dx + N dy$,

where z , M and N are functions of x and y . Differentiating M partially with respect to y , and N with respect to x

$$\left(\frac{\partial M}{\partial y} \right)_x = \frac{\partial^2 z}{\partial x \cdot \partial y}$$

$$\left(\frac{\partial N}{\partial x} \right)_y = \frac{\partial^2 z}{\partial y \cdot \partial x}$$

$$\therefore \left(\frac{\partial M}{\partial y} \right)_x = \left(\frac{\partial N}{\partial x} \right)_y \quad (11.1)$$

This is the *condition of exact (or perfect) differential*.

Theorem 2 If a quantity f is a function of x , y , and z , and a relation exists among x , y and z , then f is a function of any two of x , y , and z . Similarly any

one of x , y , and z may be regarded to be a function of f and any one of x , y , and z . Thus, if

$$x = x(f, y)$$

$$dx = \left(\frac{\partial x}{\partial f}\right)_y df + \left(\frac{\partial x}{\partial y}\right)_f dy$$

Similarly, if

$$y = y(f, z)$$

$$dy = \left(\frac{\partial y}{\partial f}\right)_z df + \left(\frac{\partial y}{\partial z}\right)_f dz$$

Substituting the expression of dy in the preceding equation

$$dx = \left(\frac{\partial x}{\partial f}\right)_y df + \left(\frac{\partial x}{\partial y}\right)_f \left[\left(\frac{\partial y}{\partial f}\right)_z df + \left(\frac{\partial y}{\partial z}\right)_f dz \right]$$

$$= \left[\left(\frac{\partial x}{\partial f}\right)_y + \left(\frac{\partial x}{\partial y}\right)_f \left(\frac{\partial y}{\partial f}\right)_z \right] df + \left(\frac{\partial x}{\partial y}\right)_f \left(\frac{\partial y}{\partial z}\right)_f dz$$

Again

$$dx = \left(\frac{\partial x}{\partial f}\right)_x df + \left(\frac{\partial x}{\partial z}\right)_f dz$$

$$\therefore \left(\frac{\partial x}{\partial z}\right)_f = \left(\frac{\partial x}{\partial y}\right)_f \left(\frac{\partial y}{\partial z}\right)_f$$

$$\therefore \left(\frac{\partial x}{\partial y}\right)_f \left(\frac{\partial y}{\partial z}\right)_f \left(\frac{\partial z}{\partial x}\right)_f = 1 \quad (11.2)$$

Theorem 3 Among the variables x , y , and z , any one variable may be considered as a function of the other two. Thus

$$x = x(y, z)$$

$$dx = \left(\frac{\partial x}{\partial y}\right)_z dy + \left(\frac{\partial x}{\partial z}\right)_y dz$$

Similarly,

$$dz = \left(\frac{\partial z}{\partial x}\right)_y dx + \left(\frac{\partial z}{\partial y}\right)_x dy$$

$$\therefore dx = \left(\frac{\partial x}{\partial y}\right)_x dy + \left(\frac{\partial x}{\partial z}\right)_y \left[\left(\frac{\partial z}{\partial x}\right)_y dx + \left(\frac{\partial z}{\partial y}\right)_x dy \right]$$

$$= \left[\left(\frac{\partial x}{\partial y}\right)_z + \left(\frac{\partial x}{\partial z}\right)_y \left(\frac{\partial z}{\partial y}\right)_x \right] dy + \left(\frac{\partial x}{\partial z}\right)_y \left(\frac{\partial z}{\partial x}\right)_y dx$$

$$= \left[\left(\frac{\partial x}{\partial y} \right)_z + \left(\frac{\partial x}{\partial z} \right)_y \left(\frac{\partial z}{\partial y} \right)_x \right] dy + dx$$

$$\therefore \left(\frac{\partial x}{\partial y} \right)_z + \left(\frac{\partial x}{\partial z} \right)_y \left(\frac{\partial z}{\partial y} \right)_x = 0$$

$$\text{or} \quad \left(\frac{\partial x}{\partial y} \right)_z \left(\frac{\partial z}{\partial x} \right)_y \left(\frac{\partial y}{\partial z} \right)_x = -1 \quad (11.3)$$

Among the thermodynamic variables p , V , and T , the following relation holds good

$$\left(\frac{\partial p}{\partial V} \right)_T \left(\frac{\partial V}{\partial T} \right)_p \left(\frac{\partial T}{\partial p} \right)_V = -1$$

11.2 Maxwell's Equations

A pure substance existing in a single phase has only two independent variables. Of the eight quantities p , V , T , S , U , H , F (Helmholtz function), and G (Gibbs function) any one may be expressed as a function of any two others.

For a pure substance undergoing an infinitesimal reversible process

$$(a) \quad dU = TdS - pdV$$

$$(b) \quad dH = dU + pdV + Vdp = TdS + Vdp$$

$$(c) \quad dF = dU - TdS - SdT = -pdV - SdT$$

$$(d) \quad dG = dH - TdS - SdT = Vdp - SdT$$

Since U , H , F and G are thermodynamic properties and exact differentials of the type

$$dz = M dx + N dy, \text{ then}$$

$$\left(\frac{\partial M}{\partial y} \right)_x = \left(\frac{\partial N}{\partial x} \right)_y$$

Applying this to the four equations

$$\left(\frac{\partial T}{\partial V} \right)_S = - \left(\frac{\partial p}{\partial S} \right)_V \quad (11.4)$$

$$\left(\frac{\partial T}{\partial p} \right)_S = \left(\frac{\partial V}{\partial S} \right)_p \quad (11.5)$$

$$\left(\frac{\partial p}{\partial T} \right)_V = \left(\frac{\partial S}{\partial V} \right)_T \quad (11.6)$$

$$\left(\frac{\partial V}{\partial T} \right)_p = - \left(\frac{\partial S}{\partial p} \right)_T \quad (11.7)$$

These four equations are known as *Maxwell's equations*.

11.3 TdS Equations

Let entropy S be imagined as a function of T and V . Then

$$dS = \left(\frac{\partial S}{\partial T}\right)_V dT + \left(\frac{\partial S}{\partial V}\right)_T dV$$

$$\therefore TdS = T\left(\frac{\partial S}{\partial T}\right)_V dT + T\left(\frac{\partial S}{\partial V}\right)_T dV$$

Since $T\left(\frac{\partial S}{\partial T}\right)_V = C_v$, heat capacity at constant volume, and

$$\left(\frac{\partial S}{\partial T}\right)_T = \left(\frac{\partial p}{\partial T}\right)_V, \text{ Maxwell's third equation,}$$

$$TdS = C_v dT + T\left(\frac{\partial p}{\partial T}\right)_V dV \quad (11.8)$$

This is known as the *first TdS equation*.

If $S = S(T, p)$

$$dS = \left(\frac{\partial S}{\partial T}\right)_p dT + \left(\frac{\partial S}{\partial p}\right)_T dp$$

$$\therefore TdS = T\left(\frac{\partial S}{\partial T}\right)_p dT + T\left(\frac{\partial S}{\partial p}\right)_T dp$$

Since $T\left(\frac{\partial S}{\partial T}\right)_p = C_p$, and $\left(\frac{\partial S}{\partial p}\right)_T = -\left(\frac{\partial V}{\partial T}\right)_p$,

then
$$TdS = C_p dT - T\left(\frac{\partial V}{\partial T}\right)_p dp \quad (11.9)$$

This is known as the *second TdS equation*.

11.4 Difference in Heat Capacities

Equating the first and second TdS equations

$$TdS = C_p dT - T\left(\frac{\partial V}{\partial T}\right)_p dp = C_v dT + T\left(\frac{\partial p}{\partial T}\right)_V dV$$

$$(C_p - C_v) dT = T\left(\frac{\partial p}{\partial T}\right)_V dV + T\left(\frac{\partial V}{\partial T}\right)_p dp$$

$$\therefore dT = \frac{T \left(\frac{\partial p}{\partial T} \right)_V}{C_p - C_v} dV + \frac{T \left(\frac{\partial V}{\partial T} \right)_p}{C_p - C_v} dp$$

Again
$$dT = \left(\frac{\partial T}{\partial V} \right)_p dV + \left(\frac{\partial T}{\partial p} \right)_V dp$$

$$\therefore \frac{T \left(\frac{\partial p}{\partial T} \right)_V}{C_p - C_v} = \left(\frac{\partial T}{\partial V} \right)_p \quad \text{and} \quad \frac{T \left(\frac{\partial V}{\partial T} \right)_p}{C_p - C_v} = \left(\frac{\partial T}{\partial p} \right)_V$$

Both these equations give

$$C_p - C_v = T \left(\frac{\partial p}{\partial T} \right)_V \left(\frac{\partial V}{\partial T} \right)_p$$

But
$$\left(\frac{\partial p}{\partial T} \right)_V \left(\frac{\partial T}{\partial V} \right)_p \left(\frac{\partial V}{\partial p} \right)_T = -1$$

$$\therefore C_p - C_v = -T \left(\frac{\partial V}{\partial T} \right)_p^2 \left(\frac{\partial p}{\partial V} \right)_T \quad (11.10)$$

This is a very important equation in thermodynamics. It indicates the following important facts.

- Since $\left(\frac{\partial V}{\partial T} \right)_p^2$ is always positive, and $\left(\frac{\partial p}{\partial V} \right)_T$ for any substance is negative, $(C_p - C_v)$ is always positive. Therefore, C_p is always greater than C_v .
- As $T \rightarrow 0$ K, $C_p \rightarrow C_v$ or at absolute zero, $C_p = C_v$.
- When $\left(\frac{\partial V}{\partial T} \right)_p = 0$ (e.g., for water at 4°C , when density is maximum, or specific volume minimum), $C_p = C_v$.
- For an ideal gas, $pV = mRT$

$$\left(\frac{\partial V}{\partial T} \right)_p = \frac{mR}{p} = \frac{V}{T}$$

and
$$\left(\frac{\partial p}{\partial V} \right)_T = -\frac{mRT}{V^2}$$

$$\therefore C_p - C_v = mR$$

or
$$c_p - c_v = R$$

Equation (11.10) may also be expressed in terms of volume expansivity (β), defined as

$$\beta = \frac{1}{V} \left(\frac{\partial V}{\partial T} \right)_p$$

and isothermal compressibility (k_T), defined as

$$k_T = - \frac{1}{V} \left(\frac{\partial V}{\partial T} \right)_T$$

$$C_p - C_v = \frac{TV \left[\frac{1}{V} \left(\frac{\partial V}{\partial T} \right)_p \right]^2}{-\frac{1}{V} \left(\frac{\partial V}{\partial p} \right)_T}$$

$$\therefore C_p - C_v = \frac{TV\beta^2}{k_T} \quad (11.11)$$

11.5 Ratio of Heat Capacities

At constant S , the two TdS equations become

$$C_p dT_s = T \left(\frac{\partial V}{\partial T} \right)_p dp_s$$

$$C_v dT_s = -T \left(\frac{\partial p}{\partial T} \right)_v dV_s$$

$$\therefore \frac{C_p}{C_v} = - \left(\frac{\partial V}{\partial T} \right)_p \left(\frac{\partial T}{\partial p} \right)_v \left(\frac{\partial p}{\partial V} \right)_s = \frac{\left(\frac{\partial p}{\partial V} \right)_s}{\left(\frac{\partial p}{\partial V} \right)_T} = \gamma$$

Since $\gamma > 1$,

$$\left(\frac{\partial p}{\partial V} \right)_s > \left(\frac{\partial p}{\partial V} \right)_T$$

Therefore, the slope of an isentrope is greater than that of an isotherm on p - v diagram (Fig. 11.1). For reversible and adiabatic compression, the work done is

$$\begin{aligned} W_s &= h_{2s} - h_1 = \int_1^{2s} v dp \\ &= \text{Area } 1-2s-3-4-1 \end{aligned}$$

For reversible and isothermal compression, the work done would be

$$\begin{aligned} W_T &= h_{2T} - h_1 = \int_1^{2T} v dp \\ &= \text{Area } 1-2T-3-4-1 \end{aligned}$$

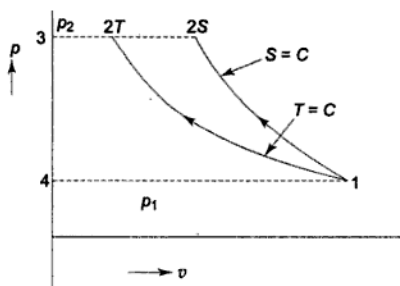

Fig. 11.1 Compression work in different reversible processes

$$\therefore W_T < W_s$$

For polytropic compression with $1 < n < \gamma$, the work done will be between these two values. So, isothermal compression requires minimum work. (See Sec. 10.4).

The adiabatic compressibility (k_s) is defined as

$$k_s = -\frac{1}{V} \left(\frac{\partial V}{\partial p} \right)_s$$

$$\therefore \frac{C_p}{C_v} = \frac{-\frac{1}{V} \left(\frac{\partial V}{\partial p} \right)_T}{-\frac{1}{V} \left(\frac{\partial V}{\partial p} \right)_s} = \gamma$$

$$\text{or } \gamma = \frac{k_T}{k_s} \quad (11.12)$$

11.6 Energy Equation

For a system undergoing an infinitesimal reversible process between two equilibrium states, the change of internal energy is

$$dU = T dS - p dV$$

Substituting the first $T dS$ equation

$$\begin{aligned} dU &= C_v dT + T \left(\frac{\partial p}{\partial T} \right)_v dV - p dV \\ &= C_v dT + \left[T \left(\frac{\partial p}{\partial T} \right)_v - p \right] dV \end{aligned} \quad (11.13)$$

$$\text{If } U = U(T, V)$$

$$dU = \left(\frac{\partial U}{\partial T}\right)_V dT + \left(\frac{\partial U}{\partial V}\right)_T dV$$

$$\left(\frac{\partial U}{\partial V}\right)_T = T \left(\frac{\partial p}{\partial T}\right)_V - p \quad (11.14)$$

This is known as the *energy equation*. Two applications of the equation are given below:

(a) For an ideal gas,
$$p = \frac{n\bar{R}T}{V}$$

$$\therefore \left(\frac{\partial p}{\partial T}\right)_V = \frac{n\bar{R}}{V} = \frac{p}{T}$$

$$\therefore \left(\frac{\partial U}{\partial V}\right)_T = T \cdot \frac{p}{T} - p = 0$$

U does not change when V changes at $T = C$.

$$\left(\frac{\partial U}{\partial p}\right)_T \left(\frac{\partial p}{\partial V}\right)_T \left(\frac{\partial V}{\partial U}\right)_T = 1$$

$$\therefore \left(\frac{\partial U}{\partial p}\right)_T \left(\frac{\partial p}{\partial V}\right)_T = \left(\frac{\partial U}{\partial V}\right)_T = 0$$

Since
$$\left(\frac{\partial p}{\partial V}\right)_T \neq 0, \left(\frac{\partial U}{\partial p}\right)_T = 0$$

U does not change either when p changes at $T = C$. So the internal energy of an ideal gas is a function of temperature only, as shown earlier in Chapter 10.

Another important point to note is that in Eq. (11.13), for an ideal gas

$$pV = n\bar{R}T \text{ and } T \left(\frac{\partial p}{\partial T}\right)_V - p = 0$$

Therefore

$$dU = C_V dT$$

holds good for an ideal gas in any process (even when the volume changes). But for any other substance

$$dU = C_V dT$$

is true only when the volume is constant and $dV = 0$.

Similarly

$$dH = TdS + Vdp$$

and

$$TdS = C_p dT - T \left(\frac{\partial V}{\partial T}\right)_p dp$$

$$\therefore dH = C_p dT + \left[V - T \left(\frac{\partial V}{\partial T} \right)_p \right] dp \quad (11.15)$$

$$\therefore \left(\frac{\partial H}{\partial p} \right)_T = V - T \left(\frac{\partial V}{\partial T} \right)_p \quad (11.16)$$

As shown for internal energy, it can be similarly proved from Eq. (11.16) that the enthalpy of an ideal gas is not a function of either volume or pressure

$$\left[\text{i.e.} \left(\frac{\partial H}{\partial p} \right)_T = 0 \text{ and } \left(\frac{\partial H}{\partial V} \right)_T = 0 \right]$$

but a function of temperature alone.

Since for an ideal gas, $pV = n\bar{R}T$

$$\text{and} \quad V - T \left(\frac{\partial V}{\partial T} \right)_p = 0$$

the relation $dH = C_p dT$ is true for any process (even when the pressure changes). However, for any other substance the relation $dH = C_p dT$ holds good only when the pressure remains constant or $dp = 0$.

(b) Thermal radiation in equilibrium with the enclosing walls possesses an energy that depends only on the volume and temperature. The energy density (u), defined as the ratio of energy to volume, is a function of temperature only, or

$$u = \frac{U}{V} = f(T) \text{ only}$$

The electromagnetic theory of radiation states that radiation is equivalent to a photon gas and it exerts a pressure, and that the pressure exerted by the black-body radiation in an enclosure is given by

$$p = \frac{u}{3}$$

Black-body radiation is thus specified by the pressure, volume, and temperature of the radiation.

$$\text{Since} \quad U = uV \text{ and } p = \frac{u}{3}$$

$$\left(\frac{\partial U}{\partial V} \right)_T = u \text{ and } \left(\frac{\partial p}{\partial T} \right)_V = \frac{1}{3} \frac{du}{dT}$$

By substituting in the energy Eq. (11.13)

$$u = \frac{T}{3} \frac{du}{dT} - \frac{u}{3}$$

$$\therefore \frac{du}{u} = 4 \frac{dT}{T}$$

$$\text{or} \quad \ln u = \ln T^4 + \ln b$$

or $u = bT^4$

where b is a constant. This is known as the *Stefan-Boltzmann Law*.

Since $U = uV = VbT^4$

$$\left(\frac{\partial U}{\partial T}\right)_V = C_v = 4VbT^3$$

and $\left(\frac{\partial p}{\partial T}\right)_V = \frac{1}{3} \frac{du}{dT} = \frac{4}{3} bT^3$

from the first TdS equation

$$\begin{aligned} TdS &= C_v dT + T \left(\frac{\partial p}{\partial T}\right)_V dV \\ &= 4VbT^3 dT + \frac{4}{3} bT^4 \cdot dV \end{aligned}$$

For a reversible isothermal change of volume, the heat to be supplied reversibly to keep temperature constant

$$Q = \frac{4}{3} bT^4 \Delta V$$

For a reversible adiabatic change of volume

$$\frac{4}{3} bT^4 dV = -4VbT^3 dT$$

$$\therefore \frac{dV}{V} = -3 \frac{dT}{T}$$

or $VT^3 = \text{const.}$

If the temperature is one-half the original temperature, the volume of black-body radiation is to be increased adiabatically eight times its original volume so that the radiation remains in equilibrium with matter at that temperature.

11.7 Joule-Kelvin Effect

A gas is made to undergo continuous throttling process by a valve, as shown in Fig. 11.2. The pressures and temperatures of the gas in the insulated pipe upstream and downstream of the valve are measured with suitable manometers and thermometers.

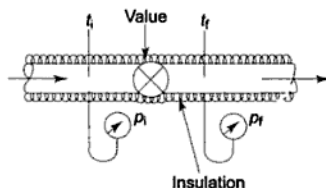

Fig. 11.2 *Joule-Thomson expansion*

Let p_i and T_i be the arbitrarily chosen pressure and temperature before throttling and let them be kept constant. By operating the valve manually, the gas is throttled successively to different pressures and temperatures $p_{f1}, T_{f1}; p_{f2}, T_{f2}; p_{f3}, T_{f3}$ and so on. These are then plotted on the T - p coordinates as shown in Fig. 11.3. All the points represent equilibrium states of some constant mass of gas, say, 1 kg, at which the gas has the *same enthalpy*.

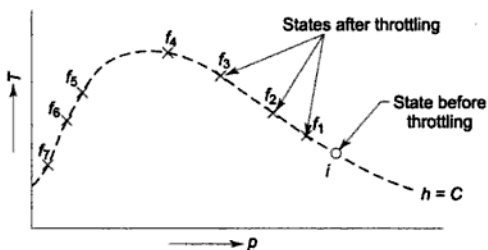

Fig. 11.3 Isenthalpic states of a gas

The curve passing through all these points is an isenthalpic curve or an *isenthalpe*. It is not the graph of a throttling process, but the graph through points of equal enthalpy.

The initial temperature and pressure of the gas (before throttling) are then set to new values, and by throttling to different states, a *family of isenthalpes* is obtained for the gas, as shown in Figs 11.4 and 11.5. The curve passing through the maxima of these isenthalpes is called the *inversion curve*.

The numerical value of the slope of an isenthalpe on a T - p diagram at any point is called the *Joule-Kelvin coefficient* and is denoted by μ_J . Thus the locus of all points at which μ_J is zero is the inversion curve. The region inside the inversion curve where μ_J is positive is called the *cooling region* and the region outside where μ_J is negative is called the *heating region*. So,

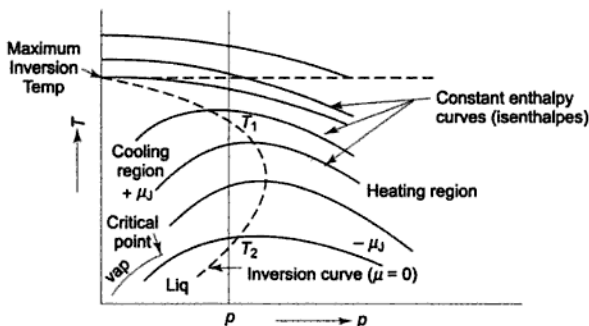

Fig. 11.4 Isenthalpic curves and the inversion curve

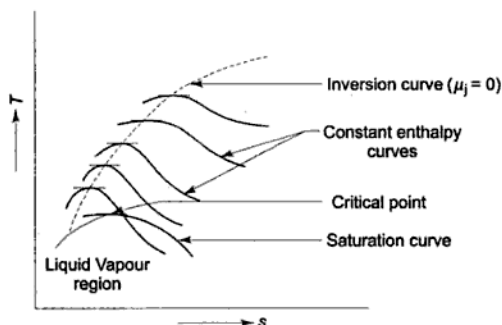

Fig. 11.5 Inversion and saturation curves on T - s plot

$$\mu_j = \left(\frac{\partial T}{\partial p} \right)_h$$

The difference in enthalpy between two neighbouring equilibrium states is

$$dh = Tds + vdp$$

and the second TdS equation (per unit mass)

$$Tds = c_p dT - T \left(\frac{\partial v}{\partial T} \right)_p dp$$

$$\therefore dh = c_p dT - \left[T \left(\frac{\partial v}{\partial T} \right)_p - v \right] dp$$

The second term in the above equation stands only for a real gas, because for an ideal gas, $dh = c_p dT$.

$$\mu_j = \left(\frac{\partial T}{\partial p} \right)_h = \frac{1}{c_p} \left[T \left(\frac{\partial v}{\partial T} \right)_p - v \right] \quad (11.17)$$

For an ideal gas

$$pv = RT$$

$$\therefore \left(\frac{\partial v}{\partial T} \right)_p = \frac{R}{p} = \frac{v}{T}$$

$$\therefore \mu_j = \frac{1}{c_p} \left(T \cdot \frac{v}{T} - v \right) = 0$$

There is no change in temperature when an ideal gas is made to undergo a Joule-Kelvin expansion (i.e. throttling).

For achieving the effect of cooling by Joule-Kelvin expansion, the initial temperature of the gas must be below the point where the inversion curve

intersects the temperature axis, i.e. below the *maximum inversion temperature*. For nearly all substances, the maximum inversion temperature is above the normal ambient temperature, and hence cooling can be obtained by the Joule-Kelvin effect. In the case of hydrogen and helium, however, the gas is to be precooled in heat exchangers below the maximum inversion temperature before it is throttled. For liquefaction the gas has to be cooled below the critical temperature.

Let the initial state of gas before throttling be at A (Fig. 11.6). The change in temperature may be positive, zero, or negative, depending upon the final pressure after throttling. If the final pressure lies between A and B , there will be a rise in temperature or heating effect. If it is at C , there will be no change in temperature. If the final pressure is below p_c , there will be a cooling effect, and if the final pressure is p_D , the temperature drop will be $(T_A - T_D)$.

Maximum temperature drop will occur if the initial state lies on the inversion curve. In Fig. 11.6, it is $(T_B - T_D)$.

The volume expansivity is

$$\beta = \frac{1}{v} \left(\frac{\partial v}{\partial T} \right)_p$$

So the Joule-Kelvin coefficient μ_J is given by, from Eq. (11.17)

$$\mu_J = \frac{1}{c_p} \left[T \left(\frac{\partial v}{\partial T} \right)_p - v \right]$$

or
$$\mu_J = \frac{v}{c_p} [\beta T - 1]$$

For an ideal gas,
$$\beta = \frac{1}{T} \text{ and } \mu_J = 0$$

There are two inversion temperatures for each pressure, e.g. T_1 and T_2 at pressure p (Fig. 11.4).

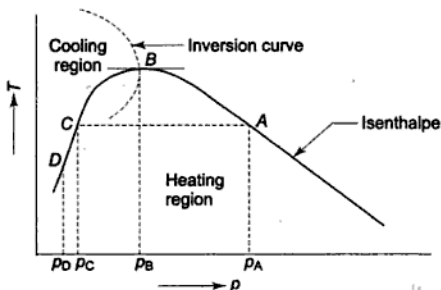

Fig. 11.6 Maximum cooling by Joule-Kelvin expansion

11.8 Clausius-Clapeyron Equation

During phase transitions like melting, vaporization and sublimation, the temperature and pressure remain constant, while the entropy and volume change. If x is the fraction of initial phase i which has been transformed into final phase f , then

$$s = (1-x)s^{(i)} + xs^{(f)}$$

$$v = (1-x)v^{(i)} + xv^{(f)}$$

where s and v are linear functions of x .

For reversible phase transition, the heat transferred per mole (or per kg) is the latent heat, given by

$$l = T\{s^{(f)} - s^{(i)}\}$$

which indicates the change in entropy.

Now $dg = -s dT + v dp$

or $s = -\left(\frac{\partial g}{\partial T}\right)_p$

and $v = \left(\frac{\partial g}{\partial p}\right)_T$

A phase change of the first order is known as any phase change that satisfies the following requirements:

- There are changes of entropy and volume.
- The first-order derivatives of Gibbs function change discontinuously.

Let us consider the first-order phase transition of one mole of a substance from phase i to phase f . Using the first TdS equation

$$TdS = c_v dT + T\left(\frac{\partial p}{\partial T}\right)_v dv$$

for the phase transition which is reversible, isothermal and isobaric, and

integrating over the whole change of phase, and since $\left(\frac{\partial p}{\partial T}\right)_v$ is independent of

v

$$T\{s^{(f)} - s^{(i)}\} = T \frac{dp}{dT} \cdot \{v^{(f)} - v^{(i)}\}$$

$$\therefore \frac{dp}{dT} = \frac{s^{(f)} - s^{(i)}}{v^{(f)} - v^{(i)}} = \frac{l}{T[v^{(f)} - v^{(i)}]} \quad (11.18)$$

The above equation is known as the *Clausius-Clapeyron equation*.

The Clausius-Clapeyron equation can also be derived in another way.

For a reversible process at constant T and p , the Gibbs function remains constant. Therefore, for the first-order phase change at T and p

$$g^{(i)} = g^{(f)}$$

and for a phase change at $T + dT$ and $p + dp$ (Fig. 11.7)

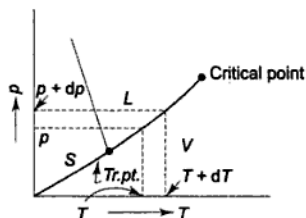

Fig. 11.7 First order phase transition

$$g^{(i)} + dg^{(i)} = g^{(f)} + dg^{(f)}$$

Subtracting

$$\begin{aligned} dg^{(i)} &= dg^{(f)} \\ &= -s^{(i)} dT + v^{(i)} dp \\ &= -s^{(f)} dT + v^{(f)} dp \end{aligned}$$

or

$$\therefore \frac{dp}{dT} = \frac{s^{(f)} - s^{(i)}}{v^{(f)} - v^{(i)}} = \frac{l}{T[v^{(f)} - v^{(i)}]}$$

For fusion

$$\frac{dp}{dT} = \frac{l_{fu}}{T(v'' - v')}$$

where l_{fu} is the latent heat of fusion, the first prime indicates the saturated solid state, and the second prime the saturated liquid state. The slope of the fusion curve is determined by $(v'' - v')$, since l_{fu} and T are positive. If the substance expands on melting, $v'' > v'$, the slope is positive. This is the usual case. Water, however, contracts on melting and has the fusion curve with a negative slope (Fig. 11.8).

For vaporization

$$\frac{dp}{dT} = \frac{l_{vap}}{T(v''' - v'')}$$

where l_{vap} is the latent heat of vaporization, and the third prime indicates the saturated vapour state.

$$\therefore l_{vap} = T \frac{dp}{dT} (v''' - v'')$$

At temperatures considerably below the critical temperature, $v''' \gg v''$ and using the ideal gas equation of state for vapour

$$v''' = \frac{RT}{p}$$

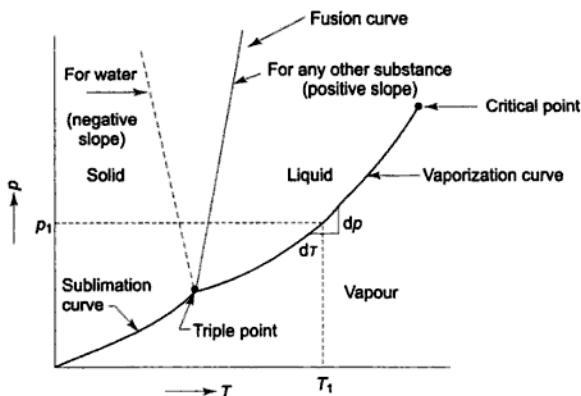

Fig. 11.8 Phase diagram for water and any other substance on p - T coordinates

$$l_{\text{vap}} \equiv T \cdot \frac{dp}{dT} \frac{RT}{p}$$

or

$$l_{\text{vap}} = \frac{RT^2}{p} \frac{dp}{dT} \quad (11.19)$$

If the slope dp/dT at any state (e.g. point p_1, T_1 in Fig. 11.8) is known, the latent heat of vaporization can be computed from the above equation.

The vapour pressure curve is of the form

$$\ln p = A + \frac{B}{T} + C \ln T + DT$$

where A, B, C and D are constants. By differentiating with respect to T

$$\frac{1}{p} \frac{dp}{dT} = -\frac{B}{T^2} + \frac{C}{T} + D \quad (11.20)$$

Equations (11.19) and (11.20) can be used to estimate the latent heat of vaporization.

Clapeyron's equation can also be used to estimate approximately the vapour pressure of a liquid at any arbitrary temperature in conjunction with a relation for the latent heat of a substance, known as *Trouton's rule*, which states that

$$\frac{\bar{h}_{fg}}{T_B} \equiv 88 \text{ kJ/kgmol K}$$

where \bar{h}_{fg} is the latent heat of vaporization in kJ/kgmol and T_B is the boiling point at 1.013 bar. On substituting this into Eq. (11.19)

$$\frac{dp}{dT} = \frac{88 T_B}{R T^2} p$$

or

$$\int_{101.325}^p \frac{dp}{p} = \frac{88 T_B}{\bar{R}} \int_{T_B}^T \frac{dT}{T^2}$$

$$\ln \frac{p}{101.325} = -\frac{88 T_B}{\bar{R}} \left(\frac{1}{T} - \frac{1}{T_B} \right)$$

$$\therefore p = 101.325 \exp \left[\frac{88}{\bar{R}} \left(1 - \frac{T_B}{T} \right) \right] \quad (11.21)$$

This gives the vapour pressure p in kPa at any temperature T .
For *sublimation*

$$\frac{dp}{dT} = \frac{l_{\text{sub}}}{T(v''' - v')}$$

where l_{sub} is the latent heat of sublimation.

Since $v''' \gg v'$, and vapour pressure is low, $v''' = \frac{RT}{p}$

$$\frac{dp}{dT} = \frac{l_{\text{sub}}}{T \cdot \frac{RT}{p}}$$

or

$$l_{\text{sub}} = -2.303 R \frac{d(\log p)}{d(1/T)}$$

the slope of $\log p$ vs. $1/T$ curve is negative, and if it is known, l_{sub} can be estimated.

At the triple point (Fig. 9.12),

$$l_{\text{sub}} = l_{\text{vap}} + l_{\text{fus}} \quad (11.23)$$

$$\left(\frac{dp}{dT} \right)_{\text{vap}} = \frac{p_{\text{tp}} l_{\text{vap}}}{\bar{R} T_{\text{tp}}^2}$$

$$\left(\frac{dp}{dT} \right)_{\text{sub}} = \frac{p_{\text{tp}} l_{\text{sub}}}{\bar{R} T_{\text{tp}}^2}$$

Since $l_{\text{sub}} > l_{\text{vap}}$, at the triple point

$$\left(\frac{dp}{dT} \right)_{\text{sub}} > \left(\frac{dp}{dT} \right)_{\text{vap}}$$

Therefore, the slope of the sublimation curve at the triple point is greater than that of the vaporization curve (Fig. 11.8).

11.9 Evaluation of Thermodynamic Properties from an Equation of State

Apart from calculating pressure, volume, or temperature, an equation of state can also be used to evaluate other thermodynamic properties such as internal energy, enthalpy and entropy. The property relations to be used are:

$$du = c_v dT + \left[T \left(\frac{\partial p}{\partial T} \right)_v - p \right] dv \quad (11.24)$$

$$dh = c_p dT + \left[v - T \left(\frac{\partial v}{\partial T} \right)_p \right] dp \quad (11.25)$$

$$\begin{aligned} ds &= \frac{1}{T} \left[c_v dT + T \left(\frac{\partial p}{\partial T} \right)_v dv \right] \\ &= \frac{1}{T} \left[c_p dT - T \left(\frac{\partial v}{\partial T} \right)_p dp \right] \end{aligned} \quad (11.26)$$

Integrations of the differential relations of the properties p , v and T in the above equations are carried out with the help of an equation of state. The changes in properties are independent of the path and depend only on the end states. Let us consider that the change in enthalpy per unit mass of a gas from a reference state O at p_0 , T_0 having enthalpy, h_0 to some other state B at p , T with enthalpy h is to be calculated (Fig. 11.9). The reversible path OB may be replaced for convenience by either path $O-a-B$ or path $O-b-B$, both also being reversible.

Path $O-a-B$:

From Eq. 11.25,

$$h_a - h_0 = \int_{T_0}^T c_p dT$$

$$h - h_a = \int_{p_0}^p \left[v - T \left(\frac{\partial v}{\partial T} \right)_p \right] dp$$

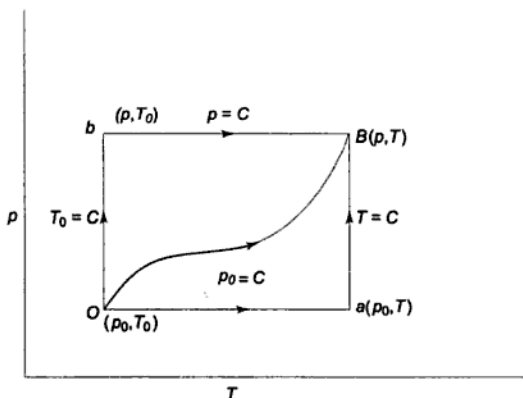

Fig. 11.9 Processes connecting states (p_0, T_0) and (p, T)

On addition,

$$h - h_0 = \left[\int_{T_0}^T c_p dT \right]_{p_0} + \left\{ \int_{p_0}^p \left[v - T \left(\frac{\partial v}{\partial T} \right)_p \right] dp \right\}_T \quad (11.27)$$

Similarly, for

Path 0-b-B:

$$h - h_0 = \left\{ \int_{p_0}^p \left[v - T \left(\frac{\partial v}{\partial T} \right)_p \right] dp \right\}_{T_0} + \left[\int_{T_0}^T c_p dT \right]_p \quad (11.28)$$

Equation (11.27) is preferred to Eq. (11.28) since c_p at lower pressure can be conveniently measured. Now,

$$\begin{aligned} \int_{p_0 v_a}^{pv} d(pv) &= \int_{v_a}^v p dv + \int_{p_0}^p v dp \\ \int_{p_0}^p v dp &= pv - p_0 v_a - \left[\int_{v_a}^v p dv \right]_T \end{aligned} \quad (11.29)$$

Again,

$$\left[\frac{\partial v}{\partial T} \right]_p \left[\frac{\partial T}{\partial p} \right]_v \left[\frac{\partial p}{\partial v} \right]_T = -1$$

$$\therefore \left[\frac{\partial v}{\partial T} \right]_p = - \left[\frac{\partial p}{\partial T} \right]_v \left[\frac{\partial v}{\partial p} \right]_T$$

Substituting in Eq. (11.27),

$$\begin{aligned} h - h_0 &= \left[\int_{T_0}^T c_p dT \right]_{p_0} + pv - p_0 v_a - \left[\int_{v_a}^v p dv \right]_T \\ &+ \left\{ \int_{p_0}^p T \left(\frac{\partial p}{\partial T} \right)_p \left(\frac{\partial v}{\partial p} \right)_T dp \right\}_T \\ &= \left[\int_{T_0}^T c_p dT \right]_{p_0} + pv - p_0 v_a - \left\{ \int_{v_a}^v \left[p - T \left(\frac{\partial p}{\partial T} \right)_v \right] dv \right\}_T \end{aligned} \quad (11.30)$$

To find the entropy change, Eq. (11.26) is integrated to yield:

$$s - s_0 = \left[\int_{T_0}^T c_p \frac{dT}{T} \right]_{p_0} - \left[\int_{p_0}^p \left(\frac{\partial v}{\partial T} \right)_p dp \right]_T$$

$$\begin{aligned}
 &= \left[\int_{T_0}^T c_p \frac{dT}{T} \right]_{p_0} - \left[- \int_{p_0}^p \left(\frac{\partial p}{\partial T} \right)_v \left(\frac{\partial v}{\partial p} \right)_T dp \right]_T \\
 &= \left[\int_{T_0}^T c_p \frac{dT}{T} \right]_{p_0} + \left[\int_{v_s}^v \left(\frac{\partial p}{\partial T} \right)_v dv \right]_T \quad (11.31)
 \end{aligned}$$

11.10 General Thermodynamic Considerations on an Equation of State

Certain general characteristics are common to all gases. These must be clearly observed in the developing and testing of an equation of state. It is edifying to discuss briefly some of the more important ones:

(i) Any equation of state must reduce to the ideal gas equation as pressure approaches zero at any temperature. This is clearly seen in a generalized compressibility factor chart in which all isotherms converge to the point $z = 1$ at zero pressure. Therefore,

$$\lim_{p \rightarrow 0} \left[\frac{pv}{RT} \right] = 1 \text{ at any temperature}$$

Also, as seen from Fig. 10.6, the reduced isotherms approach the line $z = 1$ as the temperature approaches infinity, or:

$$\lim_{T \rightarrow \infty} \left[\frac{pv}{RT} \right] = 1 \text{ at any pressure.}$$

(ii) The critical isotherm of an equation of state should have a point of inflection at the critical point on p - v coordinates, or

$$\left[\frac{\partial p}{\partial v} \right]_{T=T_c} = 0 \text{ and } \left[\frac{\partial^2 p}{\partial v^2} \right]_{T=T_c} = 0$$

(iii) The isochores of an equation of state on a p - T diagram should be essentially straight, or:

$$\left[\frac{\partial p}{\partial T} \right]_v = \text{constant}, \quad \left[\frac{\partial^2 p}{\partial T^2} \right]_v = 0 \text{ as } p \rightarrow 0, \text{ or as } T \rightarrow \infty.$$

An equation of state can predict the slope of the critical isochore of a fluid. This slope is identical with the slope of the vaporization curve at the critical point. From the Clapeyron equation, $dp/dT = \Delta s/\Delta v$, the slope of the vaporization curve at the critical point becomes:

$$\frac{dp}{dT} = \left[\frac{\partial s}{\partial v} \right]_{T_c} = \left[\frac{\partial p}{\partial T} \right]_{v_c} \quad (\text{by Maxwell's equation})$$

Therefore, the vapour-pressure slope at the critical point, dp/dT , is equal to the slope of the critical isochore $(\partial p/\partial T)_{v_c}$ (Fig. 11.10).

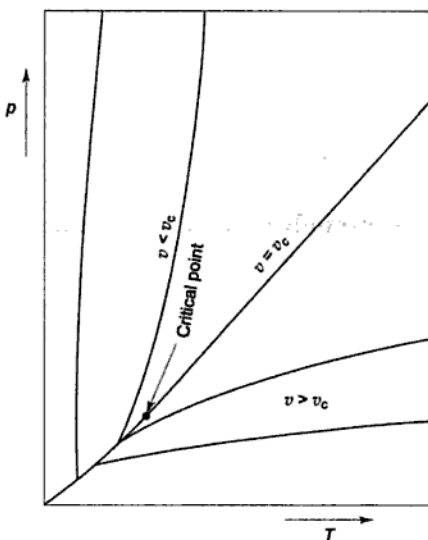

Fig. 11.10 Pressure-temperature diagram with isochoric lines

(iv) The slopes of the isotherms of an equation of state on a Z - p compressibility factor chart as p approaches zero should be negative at lower temperatures and positive at higher temperatures. At the Boyle temperature, the slope is zero as p approaches zero, or

$$\lim_{p \rightarrow 0} \left[\frac{\partial z}{\partial p} \right]_T = 0 \text{ at } T = T_B$$

An equation of state should predict the Boyle temperature which is about $2.54 T_c$ for many gases.

An isotherm of maximum slope on the Z - p plot as p approaches zero, called the *foldback isotherm*, which is about $5T_c$ for many gases, should be predicted by an equation of state, for which:

$$\lim_{p \rightarrow 0} \left[\frac{\partial^2 z}{\partial T \cdot \partial p} \right] = 0 \text{ at } T = T_F$$

where T_F is the foldback temperature (Fig. 10.10 a). As temperature increases beyond T_F the slope of the isotherm decreases, but always remains positive.

(v) An equation of state should predict the Joule-Thomson coefficient, which is

$$\mu_J = \frac{1}{c_p} \left[T \left(\frac{\partial v}{\partial T} \right)_p - v \right] = \frac{RT^2}{p c_p} \left(\frac{\partial z}{\partial T} \right)_p$$

For the inversion curve, $\mu_j = 0$,

$$\text{or,} \quad \left(\frac{\partial z}{\partial T} \right)_p = 0$$

11.11 Mixtures of Variable Composition

Let us consider a system containing a mixture of substances 1, 2, 3... K. If some quantities of a substance are added to the system, the energy of the system will increase. Thus for a system of variable composition, the internal energy depends not only on S and V , but also on the number of moles (or mass) of various constituents of the system.

Thus

$$U = U(S, V, n_1, n_2, \dots, n_K)$$

where n_1, n_2, \dots, n_K are the number of moles of substances 1, 2, ..., K. The composition may change not only due to addition or subtraction, but also due to chemical reaction and inter-phase mass transfer. For a small change in U , assuming the function to be continuous

$$\begin{aligned} dU = & \left(\frac{\partial U}{\partial S} \right)_{V, n_1, n_2, \dots, n_K} dS + \left(\frac{\partial U}{\partial V} \right)_{S, n_1, n_2, \dots, n_K} dV \\ & + \left(\frac{\partial U}{\partial n_1} \right)_{S, V, n_2, \dots, n_K} dn_1 + \left(\frac{\partial U}{\partial n_2} \right)_{S, V, n_1, n_3, \dots, n_K} dn_2 \\ & + \dots + \left(\frac{\partial U}{\partial n_K} \right)_{S, V, n_1, n_2, \dots, n_{K-1}} dn_K \end{aligned}$$

$$\text{or} \quad dU = \left(\frac{\partial U}{\partial S} \right)_{V, n_i} dS + \left(\frac{\partial U}{\partial V} \right)_{S, n_i} dV + \sum_{i=1}^K \left(\frac{\partial U}{\partial n_i} \right)_{S, V, n_j} dn_i$$

where subscript i indicates any substance and subscript j any other substance except the one whose number of moles is changing.

If the composition does not change

$$dU = TdS - pdV$$

$$\therefore \left(\frac{\partial U}{\partial S} \right)_{V, n_i} = T, \text{ and } \left(\frac{\partial U}{\partial V} \right)_{S, n_i} = -p$$

$$\therefore dU = TdS - pdV + \sum_{i=1}^K \left(\frac{\partial U}{\partial n_i} \right)_{S, V, n_j} dn_i \quad (11.32)$$

Molal chemical potential, μ , of component i is defined as

$$\mu_i = \left(\frac{\partial U}{\partial n_i} \right)_{S, V, n_j}$$

signifying the change in internal energy per unit mole of component i when S , V , and the number of moles of all other components are constant.

$$\therefore dU = TdS - pdV + \sum_{i=1}^K \mu_i dn_i$$

$$\text{or } TdS = dU + pdV - \sum_{i=1}^K \mu_i dn_i \quad (11.33)$$

This is known as *Gibbs entropy equation*.

In a similar manner

$$G = G(p, T, n_1, n_2, \dots, n_K)$$

$$\begin{aligned} \text{or } dG &= \left(\frac{\partial G}{\partial p}\right)_{T, n_i} dp + \left(\frac{\partial G}{\partial T}\right)_{p, n_i} dT + \sum_{i=1}^K \left(\frac{\partial G}{\partial n_i}\right)_{T, p, n_j} dn_i \\ &= Vdp - SdT + \sum_{i=1}^K \left(\frac{\partial G}{\partial n_i}\right)_{T, p, n_j} dn_i \end{aligned} \quad (11.34)$$

$$\text{Since } G = U + pV - TS$$

$$d(U + pV - TS) = Vdp - SdT + \sum_{i=1}^K \left(\frac{\partial G}{\partial n_i}\right)_{T, p, n_j} dn_i$$

$$\begin{aligned} \text{or } dU + pdV + Vdp - TdS - SdT \\ = Vdp - SdT + \sum_{i=1}^K \left(\frac{\partial G}{\partial n_i}\right)_{T, p, n_j} dn_i \end{aligned}$$

$$\text{or } dU = TdS - pdV + \sum_{i=1}^K \left(\frac{\partial G}{\partial n_i}\right)_{T, p, n_j} dn_i$$

Comparing this equation with Eq. (11.32)

$$\left(\frac{\partial U}{\partial n_i}\right)_{S, V, n_j} = \left(\frac{\partial G}{\partial n_i}\right)_{T, p, n_j} = \mu_i$$

\therefore Equation (11.34) becomes

$$dG = Vdp - SdT + \sum_{i=1}^K \mu_i dn_i$$

Similar equations can be obtained for changes in H and F .

Thus

$$\begin{aligned} dU &= TdS - pdV + \sum_{i=1}^K \mu_i dn_i \\ dG &= Vdp - SdT + \sum_{i=1}^K \mu_i dn_i \end{aligned}$$

$$dH = TdS + Vdp + \sum_{i=1}^K \mu_i dn_i \quad (11.35)$$

$$dF = -SdT - pdV + \sum_{i=1}^K \mu_i dn_i$$

where

$$\mu_i = \left(\frac{\partial U}{\partial n_i} \right)_{S, V, n_j} = \left(\frac{\partial G}{\partial n_i} \right)_{T, p, n_j} = \left(\frac{\partial H}{\partial n_i} \right)_{S, p, n_j} = \left(\frac{\partial F}{\partial n_i} \right)_{T, V, n_j} \quad (11.36)$$

Chemical potential is an intensive property.

Let us consider a homogeneous phase of a multi-component system, for which

$$dU = TdS - pdV + \sum_{i=1}^K \mu_i dn_i$$

If the phase is enlarged in size, U , S , and V will increase, whereas T , p and μ will remain the same. Thus

$$\Delta U = T\Delta S - p\Delta V + \sum \mu_i \Delta n_i$$

Let the system be enlarged to K -times the original size. Then

$$\Delta U = KU - U = (K - 1)U$$

$$\Delta S = KS - S = (K - 1)S$$

$$\Delta V = (K - 1)V$$

$$\Delta n_i = (K - 1)n_i$$

Substituting

$$(K - 1)U = T(K - 1)S - p(K - 1)V + \sum \mu_i (K - 1)n_i$$

$$\therefore U = TS - pV + \sum \mu_i n_i$$

$$\therefore G_{T, p} = \sum \mu_i n_i \quad (11.37)$$

Let us now find a relationship if there is a simultaneous change in intensive property. Differentiating Eq. (11.37)

$$dG = \sum n_i d\mu_i + \sum \mu_i dn_i \quad (11.38)$$

at constant T and p , with only μ changing.

When T and p change

$$dG = -SdT + Vdp + \sum \mu_i dn_i \quad (11.39)$$

Combining Equations (11.38) and (11.39)

$$-SdT + Vdp - \sum n_i d\mu_i = 0 \quad (11.40)$$

This is known as *Gibbs-Duhem equation*, which shows the necessary relationship for simultaneous changes in T , p , and μ .

Now

$$G_{T, p} = \sum \mu_i n_i = \mu_1 n_1 + \mu_2 n_2 \dots + \mu_K n_K$$

For a phase consisting of only one constituent

$$G = \mu n$$

or

$$\mu = \frac{G}{n} = g$$

i.e. the chemical potential is the molar Gibbs function and is a function of T and p only.

For a single phase, multi-component system, μ_i is a function of T , p , and the mole fraction x_i .

11.12 Conditions of Equilibrium of a Heterogeneous System

Let us consider a heterogeneous system of volume V , in which several homogeneous phases ($\phi = a, b, \dots, r$) exist in equilibrium. Let us suppose that each phase consists of $i (= 1, 2, \dots, C)$ constituents and that the number of constituents in any phase is different from the others.

Within each phase, a change in internal energy is accompanied by a change in entropy, volume and composition, according to

$$dU_\phi = T_\phi dS_\phi - p_\phi dV_\phi + \sum_{i=1}^C (\mu_i dn_i)_\phi$$

A change in the internal energy of the entire system can, therefore, be expressed as

$$\sum_{\phi=a}^r dU_\phi = \sum_{\phi=a}^r T_\phi dS_\phi - \sum_{\phi=a}^r p_\phi dV_\phi + \sum_{\phi=a}^r \sum_{i=1}^C (\mu_i dn_i)_\phi \quad (11.41)$$

Also, a change in the internal energy of the entire system involves changes in the internal energy of the constituent phases.

$$dU = dU_a + dU_b + \dots + dU_r = \sum_{\phi=a}^r dU_\phi$$

Likewise, changes in the volume, entropy, or chemical composition of the entire system result from contributions from each of the phases

$$dV = dV_a + dV_b + \dots + dV_r = \sum_{\phi=a}^r dV_\phi$$

$$dS = dS_a + dS_b + \dots + dS_r = \sum_{\phi=a}^r dS_\phi$$

$$dn = dn_a + dn_b + \dots + dn_r = \sum_{\phi=a}^r dn_\phi$$

In a closed system in equilibrium, the internal energy, volume, entropy, and mass are constant.

$$\begin{aligned} \therefore \quad & dU = dV = dS = dn = 0 \\ \text{or} \quad & dU_a = -(dU_b + \dots + dU_r) = - \sum_j dU_j \\ & dV_a = - \sum_j dV_j \\ & dS_a = - \sum_j dS_j \\ & dn_a = - \sum_j dn_j \end{aligned} \quad (11.42)$$

where subscript j includes all phases except phase a .

Equation (11.41) can be written in terms of j independent variables and the dependent variable a (Equation 11.42)

$$\begin{aligned} & \left(T_a dS_a + \sum_j T_j dS_j \right) - \left(p_a dV_a + \sum_j p_j dV_j \right) \\ & + \left[\sum_j (\mu_i dn_i)_a + \sum_j \sum_j (\mu_i dn_i)_j \right] = 0 \end{aligned}$$

Substituting from Eq. (11.42)

$$\begin{aligned} & \left(-T_a \sum_j dS_j + \sum_j T_j dS_j \right) - \left(-p_a \sum_j dV_j + \sum_j p_j dV_j \right) \\ & + \left[\sum_j \sum_j \mu_{ia} dn_{ij} + \sum_j \sum_j (\mu_i dn_i)_j \right] = 0 \end{aligned}$$

where subscript $i a$ refers to component i of phase a .

Rearranging and combining the coefficients of the independent variables, dS_j , dV_j and dn_j , gives

$$\sum_j (T_j - T_a) dS_j - \sum_j (p_j - p_a) dV_j + \sum_j \sum_i (\mu_{ij} - \mu_{ia}) dn_{ij} = 0$$

But since dS_j , dV_j , and dn_j are independent, their coefficients must each be equal to zero.

$$\therefore \quad T_j = T_a, \quad p_j = p_a, \quad \mu_{ij} = \mu_{ia} \quad (11.43)$$

These equations represent conditions that exist when the system is in thermal, mechanical, and chemical equilibrium. The temperature and pressure of phase a must be equal to those of all other phases, and the chemical potential of the i th component in phase a must be equal to the chemical potential of the same component in all other phases.

11.13 Gibbs Phase Rule

Let us consider a heterogeneous system of C chemical constituents which do not combine chemically with one another. Let us suppose that there are ϕ phases, and every constituent is present in each phase. The constituents are denoted by subscripts and the phases by superscripts. The Gibbs function of the whole heterogeneous system is

$$G_{T,p} = \sum_{i=1}^C n_i^{(1)} \mu_i^{(1)} + \sum_{i=1}^C n_i^{(2)} \mu_i^{(2)} + \dots + \sum_{i=1}^C n_i^{(\phi)} \mu_i^{(\phi)}$$

G is a function of T , p , and the n 's of which there are $C\phi$ in number. Since there are no chemical reactions, the only way in which the n 's may change is by the transport of the constituents from one phase to another. In this case the total number of moles of each constituent will remain constant.

$$n_1^{(1)} + n_1^{(2)} + \dots + n_1^{(\phi)} = \text{constant}$$

$$n_2^{(1)} + n_2^{(2)} + \dots + n_2^{(\phi)} = \text{constant}$$

$$\dots\dots\dots$$

$$n_c^{(1)} + n_c^{(2)} + \dots + n_c^{(\phi)} = \text{constant}$$

These are the *equations of constraint*.

At chemical equilibrium, G will be rendered a minimum at constant T and p , subject to these equations of constraint. At equilibrium, from Eq. (11.43).

$$\begin{aligned} \mu_{ij} &= \mu_{ia} \\ \mu_1^{(1)} &= \mu_1^{(2)} = \dots = \mu_1^{(\phi)} \\ \mu_2^{(1)} &= \mu_2^{(2)} = \dots = \mu_2^{(\phi)} \\ \dots\dots\dots \\ \mu_c^{(1)} &= \mu_c^{(2)} = \dots = \mu_c^{(\phi)} \end{aligned} \quad (11.44)$$

These are known as the *equations of phase equilibrium*. The equations of the phase equilibrium of one constituent are $(\phi - 1)$ in number. Therefore, for C constituents, there are $C(\phi - 1)$ such equations.

When equilibrium has been reached, there is no transport of matter from one phase to another. Therefore, in each phase, $\Sigma x = 1$. For ϕ phases, there are ϕ such equations available.

The state of the system at equilibrium is determined by the temperature, pressure, and $C\phi$ mole fractions. Therefore

Total number of variables = $C\phi + 2$.

Among these variables, there are $C(\phi - 1)$ equations of phase equilibrium and ϕ equations of $\Sigma x = 1$ type. Therefore

Total number of equations = $C(\phi - 1) + \phi$

If the number of variables is equal to the number of equations, the system is *nonvariant*. If the number of variables exceeds the number of equations by one, then the system is called *monovariant* and is said to have a variance of 1.

The excess of variables over equations is called the *variance, f*. Thus

$$f = (C\phi + 2) - [C(\phi - 1) + \phi]$$

or

$$f = C - \phi + 2 \quad (11.45)$$

This is known as the *Gibbs Phase Rule* for a non-reactive system. The variance ' f ' is also known as the *degree of freedom*.

For a pure substance existing in a single phase, $C = 1$, $\phi = 1$, and therefore, the variance is 2. There are two properties required to be known to fix up the state of the system at equilibrium.

If $C = 1$, $\phi = 2$, then $f = 1$, i.e. only one property is required to fix up the state of a single-component two-phase system.

If $C = 1$, $\phi = 3$, then $f = 0$. The state is thus unique for a substance; and refers to the triple point where all the three phases exist in equilibrium.

11.14 Types of Equilibrium

The thermodynamic potential which controls equilibrium in a system depends on the particular *constraints* imposed on the system. Let δQ be the amount of heat transfer involved between the system and the reservoir in an infinitesimal irreversible process (Fig. 11.11). Let dS denote the entropy change of the system and dS_0 the entropy change of the reservoir. Then, from the entropy principle

$$dS_0 + dS > 0$$

Since

$$dS_0 = -\frac{\delta Q}{T}$$

$$-\frac{\delta Q}{T} + dS > 0$$

or

$$\delta Q - TdS < 0$$

During the infinitesimal process, the internal energy of the system changes by an amount dU , and an amount of work pdV is performed. So, by the first law

$$\delta Q = dU + pdV$$

Thus the inequality becomes

$$dU + pdV - TdS < 0 \quad (11.46)$$

If the constraints are constant U and V , then the Eq. (11.46) reduces to

$$dS > 0$$

The condition of constant U and V refers to an isolated system. Therefore, entropy is the critical parameter to determine the state of thermodynamic equilibrium of an isolated system. The entropy of an isolated system always increases and reaches a maximum value when equilibrium is reached.

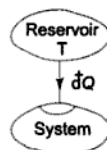

Fig. 11.11 Heat interaction between a system and its surroundings

If the constraints imposed on the system are constant T and V , the Eq. (11.46) reduces to

$$dU - d(TS) < 0$$

or

$$d(U - TS) < 0$$

\therefore

$$dF < 0$$

which expresses that the Helmholtz function decreases, becoming a minimum at the final equilibrium state.

If the constraints are constant T and p , the Eq. (11.46) becomes

$$dU + d(pV) - p(dS) < 0$$

$$d(U + pV - TS) < 0$$

$$dG < 0$$

The Gibbs function of a system at constant T and p decreases during an irreversible process, becoming a minimum at the final equilibrium state. For a system constrained in a process to constant T and p , G is the critical parameter to determine the state of equilibrium.

The thermodynamic potential and the corresponding constrained variables are shown below.

S	U	V
H		F
P	G	T

This trend of G , F , or S establishes four types of equilibrium, namely (a) stable, (b) neutral, (c) unstable, and (d) metastable.

A system is said to be in a state of *stable* equilibrium if, when the state is perturbed, the system returns to its original state. A system is not in equilibrium if there is a spontaneous change in the state. If there is a spontaneous change in the system, the entropy of the system increases and reaches a maximum when the equilibrium condition is reached (Fig. 11.12). Both A and B (Fig. 11.13) are assumed to be at the same temperature T . Let there be some spontaneous change; the temperature of A rises to $T + dT_1$, and that of B decreases to $T - dT_2$. For

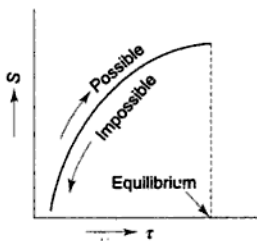

Fig. 11.12 Possible process for an isolated system

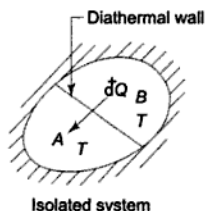

Fig. 11.13 Spontaneous changes in A and B due to heat interaction

simplicity, let the heat capacities of the bodies be the same, so that $dT_1 = dT_2$. If dQ is the heat interaction involved, then the entropy change

$$dS_A = \frac{dQ}{T + dT}, \quad dS_B = -\frac{dQ}{T - dT}$$

$$\therefore dS = dS_A + dS_B = dQ \left[\frac{1}{T + dT} - \frac{1}{T - dT} \right] = -\frac{2 \cdot dT}{T^2} \cdot dQ$$

So there is a decrease in entropy for the isolated system of A and B together. It is thus clear that the variation in temperature dT cannot take place. The system, therefore, exists in a stable equilibrium condition. Perturbation of the state produces an absurd situation and the system must revert to the original stable state. It may be observed:

If for all the possible variations in state of the isolated system, there is a negative change in entropy, then the system is in stable equilibrium.

$$\begin{array}{ll} (dS)_{U,V} > 0 & \text{Spontaneous change} \\ (dS)_{U,V} = 0 & \text{Equilibrium} \\ (dS)_{U,V} < 0 & \text{Criterion of stability} \end{array} \quad (11.47)$$

Similarly

$$\begin{array}{ll} (dG)_{p,T} < 0, (dF)_{T,V} < 0 & \text{Spontaneous change} \\ (dG)_{p,T} = 0, (dF)_{T,V} = 0 & \text{Equilibrium} \\ (dG)_{p,T} > 0, (dF)_{T,V} > 0 & \text{Criterion of stability} \end{array} \quad (11.48)$$

A system is in a state of *stable equilibrium* if, for any finite variation of the system at constant T and p , G increases, i.e. the stable equilibrium state corresponds to the minimum value of G .

A system is said to be in a state of *neutral equilibrium* when the thermodynamic criterion of equilibrium (G , F , S , U or H) remains at constant value for all possible variations of finite magnitude. If perturbed, the system does not revert to the original state.

For a system at constant T and p , the criterion of neutral equilibrium is

$$\delta G_{T,p} = 0$$

Similarly

$$\delta F_{T,V} = 0, \delta H_{S,p} = 0, \delta U_{S,V} = 0, \delta S_{U,V} = 0$$

A system is in a state of *unstable equilibrium* when the thermodynamic criterion is neither an extremum nor a constant value for all possible variations in the system. If the system is in unstable equilibrium, there will be a spontaneous change accompanied by

$$\delta G_{T,p} < 0, \delta F_{T,V} < 0, \delta U_{S,V} < 0, \delta H_{S,p} < 0, \delta S_{U,V} > 0$$

A system is in a state of *metastable equilibrium* if it is stable to small but not to large disturbances. A mixture of oxygen and hydrogen is in a metastable

equilibrium. A little spark may start a chemical reaction. Such a mixture is not in its most stable state, even though in the absence of a spark it appears to be stable.

Figure 11.14 shows different types of equilibrium together with their mechanical analogies. S has been used as the criterion for equilibrium.

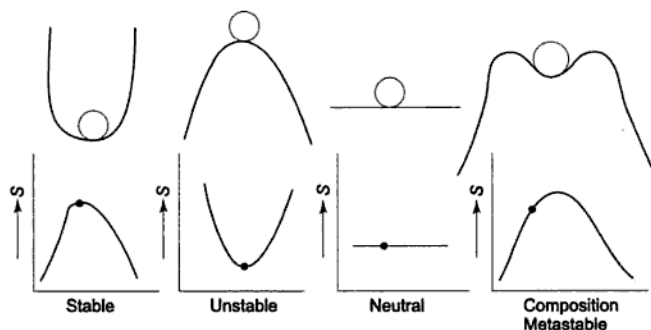

Fig. 11.14 Types of equilibrium

11.15 Local Equilibrium Conditions

Let an arbitrary division of an isolated system be considered, such that

$$S = S_1 + S_2, U = U_1 + U_2$$

Then for equilibrium, it must satisfy the condition

$$(\delta S)_{U,V} = 0$$

to first order in small displacements (otherwise δS could be made positive because of higher order terms). Now to the first order in a very small change

$$\delta_1 S = \left(\frac{\partial S}{\partial U_1} \right)_V \delta U_1 + \left(\frac{\partial S}{\partial U_2} \right)_V \delta U_2 + \left(\frac{\partial S}{\partial V_1} \right)_U \delta V_1 + \left(\frac{\partial S}{\partial V_2} \right)_U \delta V_2$$

Now

$$TdS = dU + pdV$$

$$\therefore \left(\frac{\partial S}{\partial U} \right)_V = \frac{1}{T}, \left(\frac{\partial S}{\partial V} \right)_U = \frac{p}{T}$$

$$\therefore \delta_1 S = \frac{1}{T_1} \delta U_1 + \frac{1}{T_2} \delta U_2 + \frac{p_1}{T_1} \delta V_1 + \frac{p_2}{T_2} \delta V_2$$

Again

$$\delta U_1 = -\delta U_2 \text{ and } \delta V_1 = -\delta V_2$$

$$\therefore \delta_1 S = \left(\frac{1}{T_1} - \frac{1}{T_2} \right) \delta U_1 + \left(\frac{p_1}{T_1} - \frac{p_2}{T_2} \right) \delta V_1 + \text{Second order terms}$$

When

$$\delta_1 S = 0, \text{ at equilibrium}$$

$$T_1 = T_2, \quad p_1 = p_2$$

11.16 Conditions of Stability

At equilibrium, $S = S_{\max}$, $F = F_{\min}$, $G = G_{\min}$, and $\delta S = 0$, $\delta F = 0$; $\delta G = 0$; these are necessary but not sufficient conditions for equilibrium. To prove that S is a maximum, and G or F a minimum, it must satisfy

$$\delta^2 S < 0, \delta^2 F > 0, \delta^2 G > 0$$

If the system is perturbed, and for any infinitesimal change of the system

$$(\delta S)_{U,V} < 0, (\delta G)_{p,T} > 0, (\delta F)_{T,V} > 0$$

it represents the stability of the system. The system must revert to the original state.

For a spontaneous change, from Eq. (11.46)

$$\delta U + p\delta V - T\delta S < 0$$

For stability

$$\delta U + p\delta V - T\delta S > 0$$

Let us choose $U = U(S, V)$ and expand δU in powers of δV and δS .

$$\begin{aligned} \delta U &= \left(\frac{\partial U}{\partial S}\right)_V \delta S + \frac{1}{2} \left(\frac{\partial^2 U}{\partial S^2}\right)_V (\delta S)^2 + \left(\frac{\partial U}{\partial V}\right)_S \delta V \\ &\quad + \frac{1}{2} \left(\frac{\partial^2 U}{\partial V^2}\right)_S (\delta V)^2 + \frac{\partial^2 U}{\partial V \cdot \partial S} \cdot \delta V \cdot \delta S + \dots \\ &= T\delta S - p\delta V + \frac{1}{2} \left(\frac{\partial^2 U}{\partial S^2}\right)_V (\delta S)^2 \\ &\quad + \frac{1}{2} \left(\frac{\partial^2 U}{\partial V^2}\right)_S (\delta V)^2 + \frac{\partial^2 U}{\partial V \cdot \partial S} \cdot \delta V \cdot \delta S + \dots \end{aligned}$$

The third order and higher terms are neglected.

Since $\delta U + p\delta V - T\delta S > 0$, it must satisfy the conditions given below

$$\left(\frac{\partial^2 U}{\partial S^2}\right)_V > 0, \left(\frac{\partial^2 U}{\partial V^2}\right)_S > 0, \frac{\partial^2 U}{\partial V \cdot \partial S} > 0$$

These inequalities indicate how the signs of some important physical quantities become restricted for a system to be stable.

Since
$$\left(\frac{\partial U}{\partial S}\right)_V = T$$

$$\left(\frac{\partial^2 U}{\partial S^2}\right)_V = \left(\frac{\partial T}{\partial S}\right)_V = \frac{T}{C_V}$$

\therefore
$$\frac{T}{C_V} > 0$$

Since $T > 0$ K

$$\therefore C_v > 0 \quad (11.49)$$

which is the condition of *thermal stability*.

$$\begin{aligned} \text{Also} \quad \left(\frac{\partial U}{\partial V}\right)_S &= -p \\ \left(\frac{\partial^2 U}{\partial V^2}\right)_S &= -\left(\frac{\partial p}{\partial V}\right)_S \\ \therefore \left(\frac{\partial p}{\partial V}\right)_S &< 0 \end{aligned} \quad (11.50)$$

i.e. the adiabatic bulk modulus must be negative.

Similarly, if $F = F(T, V)$, then by Taylor's expansion, and using appropriate substitution

$$\begin{aligned} \delta F &= -S\delta T - p\delta V + \frac{1}{2}\left(\frac{\partial^2 F}{\partial V^2}\right)_T (\delta V)^2 + \frac{1}{2}\left(\frac{\partial^2 F}{\partial T^2}\right)_S (\delta T)^2 \\ &\quad + \frac{\partial^2 F}{\partial V \cdot \partial T} \cdot \delta V \cdot \delta T + \dots \end{aligned}$$

For stability

$$\delta F + S\delta T + p\delta V > 0$$

$$\left(\frac{\partial^2 F}{\partial V^2}\right)_T > 0$$

Again

$$\left(\frac{\partial F}{\partial V}\right)_T = -p$$

$$\therefore \left(\frac{\partial^2 F}{\partial V^2}\right)_T = -\left(\frac{\partial p}{\partial V}\right)_T$$

$$\therefore \left(\frac{\partial p}{\partial V}\right)_T < 0 \quad (11.51)$$

which is known as the condition of *mechanical stability*. The isothermal bulk modulus must also be negative.

11.17 Third Law of Thermodynamics

From Kelvin-Planck statement of second law, it can be inferred that by the use of a finite number of cyclic heat engines, absolute zero temperature cannot be attained. But third law is itself a fundamental law of nature, not as derivable from the second law. As the other laws (zeroth, first and second), the third law also cannot be proved. It is always found to be obeyed by nature and not violated.

By using Joule-Kelvin expansion, a temperature below 5K is possible to obtain by producing liquid helium. Still lower temperatures can be attained by adiabatic demagnetisation of a paramagnetic salt.

Temperatures as low as 0.001K have been achieved by magnetic cooling. The magnetic properties of a substance can be classified as either diamagnetic where the substance is repelled by a magnet, or paramagnetic such as iron, which is attracted by a magnet. A paramagnetic salt, such as gadolinium sulphate is used for magnetic cooling. When the salt is cooled to a very low temperature, its molecules act as tiny magnets and align themselves when subjected to a magnetic field.

In 1926–27, Giaque and Debye independently suggested that the low temperature properties of certain paramagnetic salts might be used for attainment of temperature below 1K. Original experiments were conducted at Berkeley and at Lieden in 1933.

In magnetic cooling low temperatures are achieved by adiabatic demagnetisation of paramagnetic salts. The actual process consists of four steps:

1. A paramagnetic salt is cooled slightly below 1K by surrounding it with liquid helium boiling under reduced pressure.
2. Then a strong magnetic field of about 25000 gauss is applied. This makes the magnetic carriers, i.e., paramagnetic ions orient themselves parallel to the direction of the field. This realignment of atoms requires work. This work is converted into internal energy increase, which is taken up by the evaporating helium.
3. The salt is thermally insulated from the helium bath.
4. Finally, the magnetic field is removed. The molecules disalign themselves, which requires energy. This energy is obtained by the salt getting still cooler in the process.

This process of adiabatic demagnetisation is almost reversible, and the entropy remains constant.

The salt is hung by a fine nylon thread inside the salt tube such that it does not touch the sides (Fig. 11.15). The salt is first cooled to about 1K by reducing the pressure of liquid helium. Next, the salt is exposed to a strong magnetic field of about 25000 gauss. Heat produced by magnetisation of the salt is transferred to the liquid helium without causing an increase in salt temperature. With the magnetic field still present, the inner chamber containing the salt is evacuated of gaseous helium. The salt is then almost completely thermally isolated upon removal of the magnetic field, and the salt temperature decreases in an almost perfectly isentropic way. Temperatures of the salt as low as 0.001K have been reported.

An interesting and important problem in adiabatic demagnetisation is the determination of the very low temperatures produced. In the neighbourhood of absolute zero all ordinary methods of temperature measurement fail. The temperature may be calculated approximately by the Curie's law,

$$\chi = C/T$$

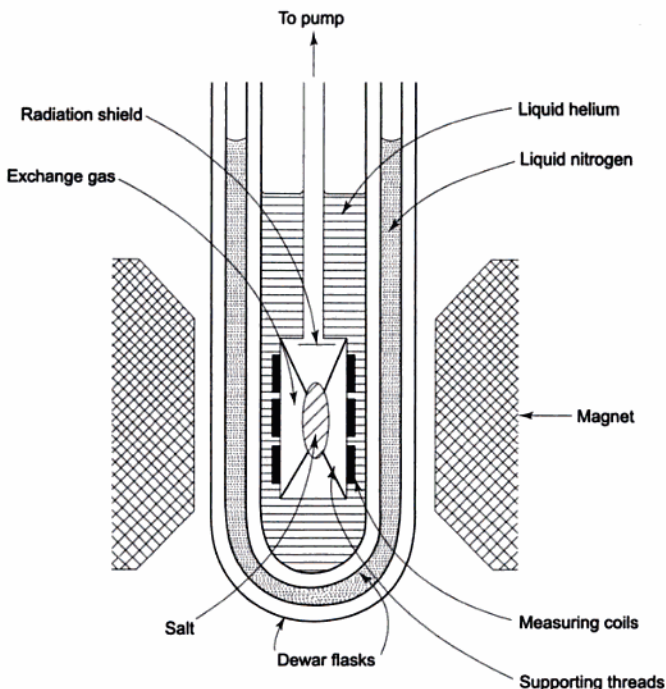

Fig. 11.15 *Adiabatic demagnetisation of a paramagnetic salt*

where χ is the magnetic susceptibility of the salt, T is the absolute temperature and C is the Curie's constant. Through magnetic measurements, the absolute temperature may be calculated.

The fundamental features of all cooling processes is that the lower the temperature achieved, the harder it is to go still lower.

Experiments indicate that the final temperature T_f achieved by adiabatic demagnetisation is roughly proportional to the initial temperature T_i . If the first demagnetisation produces a temperature one half that at the start ($T_f = \frac{1}{2} T_i$), the second demagnetisation from the same initial field will cut the temperature in half again and so on. Eventually, an infinite number of adiabatic demagnetisations would be required to attain absolute zero.

Generalizing from experience, we may accept as true the statement that:

"It is impossible by any procedure, no matter how idealized, to reduce any condensed system to the absolute zero of temperature in a finite number of operations".

This is the principle of the unattainability of absolute zero, called the *Fowler-Guggenheim statement of Third law*.

Any isothermal magnetization from 0 to H_1 (magnetic intensity) such as $k-i_1$, f_1-i_2 etc. is associated with a release of heat, i.e., a decrease in entropy (Fig. 11.16). The processes i_1-f_1 , i_2-f_2 , i_3-f_3 etc. represent reversible adiabatic demagnetisations with temperature getting lower and lower. Repeated cycles of isothermal magnetization and adiabatic demagnetisation would bring about a very low temperature. It is seen that $\{S(T, H_1) - S(T, 0)\}$ decreases as the temperature decreases, i.e., $\Delta S_{III} < \Delta S_{II} < \Delta S_I$. It is accepted from experimental evidence that: "The entropy change associated with any isothermal reversible process of a condensed system approaches zero as the temperature approaches zero".

That is, $\lim_{T \rightarrow 0} \Delta S_T = 0$. This is called the *Nernst-Simon statement of third law*.

The condensed system here refers to a solid or liquid.

Just like the proof of the equivalence of the Kelvin-Planck and Clausius statements of second law, it can also be shown that the Fowler-Guggenheim and Nernst-Simon statements of third law are equivalent in all respects (see Zemansky). The violation of one statement implies the violation of the other.

Now, it can be seen (Fig. 11.16) that in the process $k-i_1$, entropy decreases by a certain amount, in i_1-f_1 entropy remains constant, in f_1-i_2 entropy decreases further, and so on. If the entropy of the system at absolute zero is called the *zero-point entropy*, a third equivalent statement of third law can be expressed as follows:

"It is impossible by any procedure, no matter how idealized, to reduce the entropy of a system to its zero-point value in a finite number of operations".

There are many physical and chemical facts which substantiate the third law. For any phase change that takes place at low temperature, Clausius-Clapeyron equation:

$$\frac{dp}{dT} = \frac{s_f - s_i}{v_f - v_i}$$

holds good. From third law, $\lim_{T \rightarrow 0} (s_f - s_i) = 0$ and since $v_f - v_i$ is not zero, it shows that:

$$\lim_{T \rightarrow 0} \frac{dp}{dT} = 0$$

This is substantiated by all known sublimation curves. It is known that:

$$\Delta G = \Delta H - T \Delta S$$

Experience shows that the last term is very small, particularly at low temperatures (Fig. 11.17) leading to

$$\lim_{T \rightarrow 0} \Delta G = \Delta H \quad (11.52)$$

which confirms that $\lim \Delta S = 0$ as $T \rightarrow 0$.

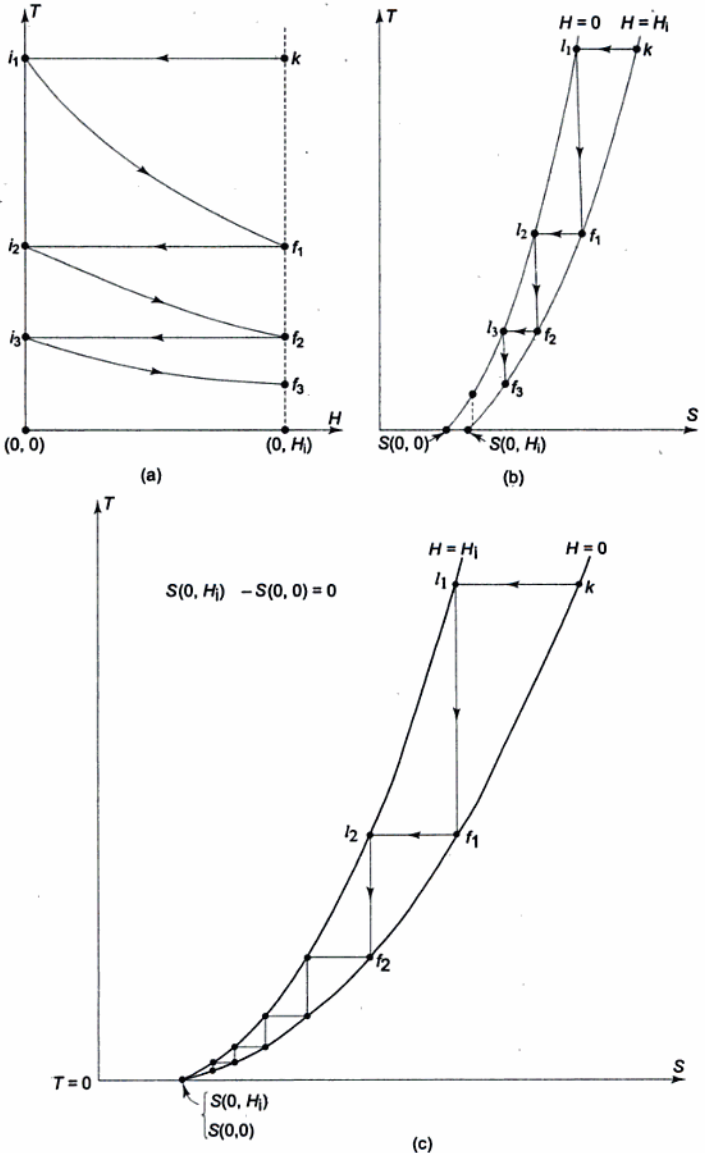

Fig. 11.16 T - H and T - S diagrams of a paramagnetic substance to show the equivalence of three statements of the third law

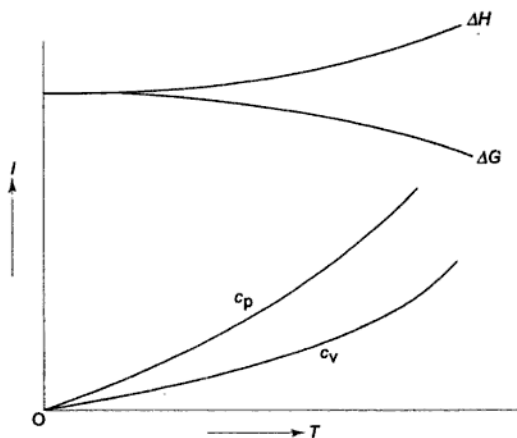

Fig. 11.17 $\Delta G \rightarrow \Delta H$ and $c_p \rightarrow c_v$ as $T \rightarrow 0$

From the Gibbs-Helmholtz equation

$$\Delta G = \Delta H + T \left[\frac{\partial \Delta G}{\partial T} \right]_p, \quad (11.53)$$

since $\lim (\Delta G - \Delta H) \rightarrow 0$ as $T \rightarrow 0$,

$$\lim \left[\frac{\partial \Delta G}{\partial T} \right]_p = 0 \text{ or } \lim \Delta S = 0 \text{ as } T \rightarrow 0$$

Again,
$$\lim \frac{\Delta G - \Delta H}{T} = \lim \frac{\partial G}{\partial T} \text{ as } T \rightarrow 0 \quad (11.54)$$

By L'Hospital's rule, the left hand side is equal to:

$$\lim \left[\frac{\partial G}{\partial T} - \frac{\partial H}{\partial T} \right] = \lim \frac{\partial G}{\partial T} - \lim c_p \quad (11.55)$$

Therefore, at absolute zero we must have for any system,

$$\lim c_p = 0 \text{ as } T \rightarrow 0 \quad (11.56)$$

and similarly, using the Gibbs-Helmholtz equation connecting F and U

$$\lim C_v = 0 \text{ as } T \rightarrow 0 \quad (11.57)$$

At very low temperatures, Debye showed that:

$$C_p = C_v = 464.4 T^3/\theta^3 \quad (11.58)$$

where θ is the Debye temperature, a characteristic of a given substance. Thus, for any material

$$C_p \cong C_v = KT^3$$

and at $T = 0$,

$$C_p = C_v = 0. \quad (11.59)$$

SOLVED EXAMPLES

Example 11.1 (a) Derive the equation

$$\left(\frac{\partial C_p}{\partial p}\right)_T = -T\left(\frac{\partial^2 V}{\partial T^2}\right)_p$$

(b) Prove that C_p of an ideal gas is a function of T only.

(c) In the case of a gas obeying the equation of state

$$\frac{p\bar{v}}{\bar{R}T} = 1 + B'p$$

where B' is a function of T only, show that

$$C_p = -\bar{R}T p \frac{d^2}{dT^2}(B'T) + (C_p)_0$$

where $(C_p)_0$ is the value at very low pressures.

Solution

$$(a) \quad C_p = T\left(\frac{\partial S}{\partial T}\right)_p$$

$$\left(\frac{\partial C_p}{\partial p}\right)_p = T \frac{\partial^2 S}{\partial T \cdot \partial p}$$

Now $\left(\frac{\partial S}{\partial p}\right)_T = -\left(\frac{\partial V}{\partial T}\right)_p$, by Maxwell's relation

$$\therefore \frac{\partial^2 S}{\partial p \cdot \partial T} = -\left(\frac{\partial^2 V}{\partial T^2}\right)_p$$

$$\therefore \left(\frac{\partial C_p}{\partial p}\right)_T = -T\left(\frac{\partial^2 V}{\partial T^2}\right)_p \quad \text{Proved.}$$

(b) For an ideal gas

$$V = \frac{n\bar{R}T}{p}$$

$$\left(\frac{\partial V}{\partial T}\right)_p = \frac{n\bar{R}}{p} \quad \text{and} \quad \left(\frac{\partial^2 V}{\partial T^2}\right)_p = 0$$

$$\therefore \left(\frac{\partial C_p}{\partial p}\right)_T = 0, \text{ i.e. } C_p \text{ is a function of } T \text{ alone.}$$

$$(c) \quad \frac{p\bar{v}}{\bar{R}T} = 1 + B'p$$

$$\begin{aligned} \therefore B'p &= \frac{p\bar{v}}{RT} - 1 \\ B'T &= \frac{T}{p} \left(\frac{p\bar{v}}{RT} - 1 \right) = \left(\frac{\bar{v}}{R} - \frac{T}{p} \right) \\ \left[\frac{\partial}{\partial T} (B'T) \right]_p &= + \frac{1}{R} \left(\frac{\partial \bar{v}}{\partial T} \right)_p - \frac{1}{p} \\ \left[\frac{\partial^2 (B'T)}{\partial T^2} \right]_p &= \frac{1}{R} \left(\frac{\partial^2 \bar{v}}{\partial T^2} \right)_p = - \frac{1}{RT} \left(\frac{\partial \bar{C}_p}{\partial p} \right)_T \end{aligned}$$

\therefore On integration

$$\bar{C}_p = - \bar{R}Tp \frac{d^2}{dT^2} (B'T) + \bar{C}_{p0}$$

where \bar{C}_{p0} (integration constant) is the value of \bar{C}_p at very low values of pressure.

Example 11.2 The Joule-Kelvin coefficient μ_j is a measure of the temperature change during a throttling process. A similar measure of the temperature change produced by an isentropic change of pressure is provided by the coefficient μ_s , where

$$\mu_s = \left(\frac{\partial T}{\partial p} \right)_s$$

Prove that

$$\mu_s - \mu_j = \frac{V}{C_p}$$

Solution The Joule-Kelvin coefficient μ_j , is given by

$$\frac{T \left(\frac{\partial V}{\partial T} \right)_p - V}{C_p}$$

Since $C_p = T \left(\frac{\partial S}{\partial T} \right)_p$ and by Maxwell's relation

$$\begin{aligned} \left(\frac{\partial V}{\partial T} \right)_p &= - \left(\frac{\partial S}{\partial p} \right)_T \\ \mu_j &= \frac{-T \left(\frac{\partial S}{\partial p} \right)_T - V}{T \left(\frac{\partial S}{\partial T} \right)_p} = \frac{V}{C_p} \end{aligned}$$

$$\therefore \mu_j = - \left(\frac{\partial S}{\partial p} \right)_T \left(\frac{\partial T}{\partial S} \right)_p - \frac{V}{C_p}$$

Since $\left(\frac{\partial S}{\partial p} \right)_T \left(\frac{\partial T}{\partial S} \right)_p \left(\frac{\partial p}{\partial T} \right)_s = -1$

$$\mu_j = + \mu_s - \frac{V}{C_p}$$

$$\therefore \mu_s - \mu_j = \frac{V}{C_p} \quad \text{Proved.}$$

Alternative method:

From the second TdS equation

$$TdS = C_p dT - T \left(\frac{\partial V}{\partial T} \right)_p dp$$

$$\left(\frac{\partial T}{\partial p} \right)_s = \mu_s = \frac{T}{C_p} \left(\frac{\partial V}{\partial T} \right)_p$$

Now $\mu_j = \frac{T}{C_p} \left[T \left(\frac{\partial V}{\partial T} \right)_p - V \right]$

$$\mu_s - \mu_j = \frac{V}{C_p} \quad \text{Proved.}$$

Example 11.3 If the boiling point of benzene at 1 atm pressure is 353 K, estimate the approximate value of the vapour pressure of benzene at 303 K.

Solution Using Clapeyron's equation and Trouton's rule, Eq. (11.21),

$$\begin{aligned} p &= 101.325 \exp \left\{ \frac{88}{R} \left(1 - \frac{T_B}{T} \right) \right\} \\ &= 101.325 \exp \left\{ \frac{88}{8.3143} \left(1 - \frac{353}{303} \right) \right\} \\ &= 17.7 \text{ kPa} \quad \text{Ans.} \end{aligned}$$

Example 11.4 The vapour pressure, in mm of mercury, of solid ammonia is given by

$$\ln p = 23.03 - \frac{3754}{T}$$

and that of liquid ammonia by

$$\ln p = 19.49 - \frac{3063}{T}$$

(a) What is the temperature of the triple point? What is the pressure? (b) What are the latent heats of sublimation and vaporization? (c) What is the latent heat of fusion at the triple point?

Solution At the triple point, the saturated solid and saturated liquid lines meet.

$$23.03 - \frac{3754}{T} = 19.49 - \frac{3063}{T}$$

$$\therefore T = 195.2 \text{ K} \quad \text{Ans. (a)}$$

$$\ln p = 23.03 - \frac{3754}{195.2}$$

$$\ln p = 3.80$$

$$p = 44.67 \text{ mm Hg} \quad \text{Ans.}$$

With the assumptions, $v''' \gg v'$ and $v''' \sim \frac{\bar{R}T}{p}$

Clausius-Clapeyron equation reduces to

$$\frac{dp}{dT} = \frac{p}{RT^2} \cdot l_{\text{sub}}$$

where l_{sub} is the latent heat of sublimation.

The vapour pressure of solid ammonia is given by

$$\ln p = 23.03 - \frac{3754}{T}$$

$$\therefore \frac{1}{p} \cdot \frac{dp}{dT} = \frac{3754}{T^2}$$

$$\therefore \frac{dp}{dT} = 3754 \frac{p}{T^2} = \frac{p}{RT^2} \cdot l_{\text{sub}}$$

$$l_{\text{sub}} = 3754 \times 8.3143 = 31,200 \text{ kJ/kgmol} \quad \text{Ans. (b)}$$

The vapour pressure of liquid ammonia is given by

$$\ln p = 19.49 - \frac{3063}{T}$$

$$\therefore \frac{dp}{dT} = 3063 \frac{p}{T^2} = \frac{p}{RT^2} \cdot l_{\text{vap}}$$

when l_{vap} is the latent heat of vaporization

$$l_{\text{vap}} = 3063 \times 8.3143 = 25,500 \text{ kJ/kgmol} \quad \text{Ans. (b)}$$

At the triple point

$$l_{\text{sub}} = l_{\text{vap}} + l_{\text{fu}}$$

where l_{fu} is the latent heat of fusion.

$$\begin{aligned} l_{\text{fu}} &= l_{\text{sub}} - l_{\text{vap}} \\ &= 31,200 - 25,500 = 5,700 \text{ kJ/kgmol} \end{aligned} \quad \text{Ans. (c)}$$

Example 11.5 Explain why the specific heat of a saturated vapour may be negative.

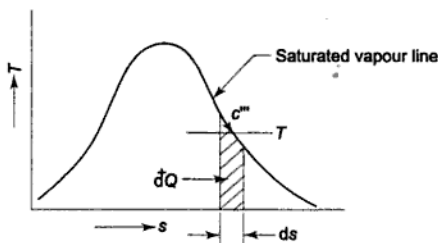

Fig. Ex. 11.5

Solution As seen in Fig. Ex. 11.5, if heat is transferred along the saturation line, there is a decrease in temperature. The slope of the saturated vapour line is negative, i.e. when dS is positive, dT is negative. Therefore, the specific heat at constant saturation

$$C_{\text{sat}}''' = T \left(\frac{\partial S'''}{\partial T} \right)$$

is negative. From the second TdS equation

$$TdS = C_p dT - T \left(\frac{\partial V}{\partial T} \right)_p dp$$

$$T \frac{dS''}{dT} = C_p - T \left(\frac{dV'''}{dT} \right)_p \left(\frac{dp}{dT} \right)_{\text{sat}}$$

$$= C_p - T \cdot \frac{n\bar{R}}{p} \cdot \frac{l_{\text{vap}}}{T(V''' - V'')} \quad [\text{using } pV''' = n\bar{R}T \text{ and Clapeyron's equation}]$$

$$C_{\text{sat}}''' = C_p \frac{V'''}{T} \cdot \frac{l_{\text{vap}}}{V'''} \quad [\because V''' \gg V'']$$

$$\therefore C_{\text{sat}}''' = C_p - \frac{l_{\text{vap}}}{T}$$

Now the value of l_{vap}/T for common substances is about 83.74 J/g mol K (*Trouton's rule*), where C_p is less than 41.87 J/g mol K. Therefore, C_{sat}''' can be negative. Proved.

Example 11.6 (a) Establish the condition of equilibrium of a closed composite system consisting of two simple systems separated by a movable diathermal wall that is impervious to the flow of matter.

(b) If the wall were rigid and diathermal, permeable to one type of material, and impermeable to all others, state the condition of equilibrium of the composite system.

(c) Two particular systems have the following equations of state

$$\frac{1}{T_1} = \frac{3}{2} \bar{R} \frac{N_1}{U_1}, \quad \frac{p_1}{T_1} = \frac{N_1}{V_1} \bar{R}$$

and

$$\frac{1}{T_2} = \frac{3}{2} \bar{R} \frac{N_2}{U_2}, \quad \frac{p_2}{T_2} = \bar{R} \frac{N_2}{V_2}$$

where $\bar{R} = 8.3143 \text{ kJ/kg mol K}$, and the subscripts indicate systems 1 and 2. The mole number of the first system is $N_1 = 0.5$, and that of the second is $N_2 = 0.75$. The two systems are contained in a closed adiabatic cylinder, separated by a movable diathermal piston. The initial temperatures are $T_1 = 200 \text{ K}$ and $T_2 = 300 \text{ K}$, and the total volume is 0.02 m^3 . What is the energy and volume of each system in equilibrium? What is the pressure and temperature?

Solution For the composite system, as shown in Fig. Ex. 11.6 (a)

$$U_1 + U_2 = \text{constant}$$

$$V_1 + V_2 = \text{constant}$$

The values of U_1 , U_2 , V_1 , and V_2 would change in such a way as to maximize the value of entropy. Therefore, when the equilibrium condition is achieved

$$dS = 0$$

for the whole system. Since

$$S = S_1 + S_2 \\ = S_1(U_1, V_1, \dots, N_{k_1} \dots) + S_2(U_2, V_2, \dots, N_{k_2} \dots)$$

$$\therefore dS = \left(\frac{\partial S_1}{\partial U_1} \right)_{V_1, \dots, N_{k_1} \dots} dU_1 + \left(\frac{\partial S_1}{\partial V_1} \right)_{U_1, \dots, N_{k_1} \dots} dV_1$$

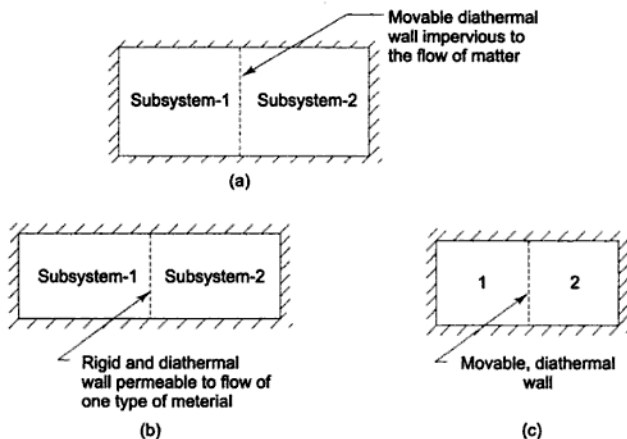

Fig. Ex. 11.6

$$\begin{aligned}
 & + \left(\frac{\partial S_2}{\partial U_2} \right)_{V_2, \dots, N_{k_2}, \dots} dU_2 + \left(\frac{\partial S_2}{\partial V_2} \right)_{V_2, \dots, N_{k_2}, \dots} dV_2 \\
 & = \frac{1}{T_1} dU_1 + \frac{P_1}{T_1} dV_1 + \frac{1}{T_2} dU_2 + \frac{P_2}{T_2} dV_2
 \end{aligned}$$

Since $dU_1 + dU_2 = 0$ and $dV_1 + dV_2 = 0$

$$\therefore dS = \left(\frac{1}{T_1} - \frac{1}{T_2} \right) dU_1 + \left(\frac{P_1}{T_1} - \frac{P_2}{T_2} \right) dV_1 = 0$$

Since the expression must vanish for arbitrary and independent values of dU_1 and dV_1

$$\frac{1}{T_1} - \frac{1}{T_2} = 0 \text{ and } \frac{P_1}{T_1} - \frac{P_2}{T_2} = 0$$

or

$$P_1 = P_2 \text{ and } T_1 = T_2$$

\therefore These are the conditions of mechanical and thermal equilibrium.

(b) We will consider the equilibrium state of two simple subsystems (Fig. Ex. 11.6 (b)) connected by a rigid and diathermal wall, permeable to one type of material (N_1) and impermeable to all others (N_2, N_3, \dots, N_r). We thus seek the equilibrium values of U_1 and of U_2 , and of N_{1-1} and N_{1-2} (i.e. material N_1 in subsystems 1 and 2 respectively.)

At equilibrium, an infinitesimal change in entropy is zero

$$dS = 0$$

Now

$$\begin{aligned}
 dS &= dS_1 + dS_2 \\
 &= \left(\frac{\partial S_1}{\partial U_1} \right)_{V_1, N_{1-1}, \dots} dU_1 + \left(\frac{\partial S_1}{\partial N_{1-1}} \right)_{U_1, V_1, N_{1-2}, \dots} dN_{1-1} \\
 &+ \left(\frac{\partial S_2}{\partial U_2} \right)_{V_2, N_{1-2}, \dots} dU_2 + \left(\frac{\partial S_2}{\partial N_{1-2}} \right)_{U_2, V_2, N_{2-2}, \dots} dN_{1-2}
 \end{aligned}$$

From the equation

$$TdS = dU + pdV - \mu dN$$

$$\therefore \left(\frac{\partial S}{\partial U} \right)_{V, N, \dots} = \frac{1}{T}, \left(\frac{\partial S}{\partial N} \right)_{U, V} = -\frac{\mu}{T}$$

and

$$\begin{aligned}
 dN_{1-1} + dN_{1-2} &= 0 \\
 dU_1 + dU_2 &= 0
 \end{aligned}$$

$$dS = \left(\frac{1}{T_1} - \frac{1}{T_2} \right) dU_1 - \left(\frac{\mu_{1-1}}{T_1} - \frac{\mu_{1-2}}{T_2} \right) dN_{1-1} = 0$$

As dS must vanish for arbitrary values of both dU_1 and dN_{1-1}

$$T_1 = T_2$$

$$\mu_{1-1} = \mu_{1-2}$$

which are the conditions of thermal and chemical equilibrium.

$$\begin{aligned}
 \text{(c)} \quad N_1 &= 0.5 \text{ g mol}, \quad N_2 = 0.75 \text{ g mol} \\
 T_{1-1} &= 200 \text{ K}, \quad T_{1-2} = 300 \text{ K} \\
 V &= V_1 + V_2 = 0.02 \text{ m}^3 \\
 U_1 + U_2 &= \text{constant} \\
 \Delta U_1 + \Delta U_2 &= 0
 \end{aligned}$$

Let T_f be the final temperature (Fig. Ex. 11.6 (c))

$$(U_{f-1} - U_{i-1}) = -(U_{f-2} - U_{i-2})$$

$$\frac{3}{2} \bar{R} N_1 (T_f - T_{i-1}) = -\frac{3}{2} \bar{R} N_2 (T_f - T_{i-2})$$

$$0.5(T_f - 200) = -0.75(T_f - 300)$$

$$\therefore 1.25 T_f = 325$$

$$\text{or } T_f = 260 \text{ K}$$

Ans.

$$U_{f-1} = \frac{3}{2} \bar{R} N_1 T_f = \frac{3}{2} \times 8.3143 \times 0.5 \times 10^{-3} \times 260 = 1.629 \text{ kJ}$$

$$U_{f-2} = \frac{3}{2} \times 8.3143 \times 0.75 \times 10^{-3} \times 260 = 2.430 \text{ kJ}$$

$$V_{f-2} = \frac{\bar{R} N_1 T_{f-1}}{P_{f-1}} \quad \text{At equilibrium}$$

$$P_{f-1} = P_{f-2} = P_f$$

Ans.

$$V_{f-2} = \frac{\bar{R} N_2 T_{f-2}}{P_{f-2}}, \quad T_{f-1} = T_{f-2} = T_f$$

$$V_{f-1} + V_{f-2} = \frac{\bar{R} T_f}{P_f} (N_1 + N_2) = 0.02 \text{ m}^3$$

$$\frac{8.3143 \times 260}{P_f} \times 1.25 \times 10^{-3} = 0.02 \text{ m}^3$$

$$\therefore P_f = \frac{8.3143 \times 260 \times 1.25 \times 10^{-3}}{0.02} \text{ kN/m}^2$$

$$= 135 \text{ kN/m}^2 = 1.35 \text{ bar}$$

$$\therefore V_{f-1} = \frac{8.3143 \times 0.5 \times 10^{-3} \times 260}{135} = 0.008 \text{ m}^3$$

$$\therefore V_{f-2} = 0.02 - 0.008 = 0.012 \text{ m}^3$$

Ans.

Example 11.7 Show that for a van der Waals' gas

$$\text{(a) } \left(\frac{\partial c_v}{\partial v} \right)_T = 0$$

$$\text{(b) } (s_2 - s_1)_T = R \ln \frac{v_2 - b}{v_1 - b}$$

(c) $T(v-b)^{R/c_v} = \text{constant}$, for an isentropic

$$(d) \quad c_p - c_v = \frac{R}{1 - 2a(v-b)^2/RTv^3}$$

$$(e) \quad (h_2 - h_1)_T = (p_2 v_2 - p_1 v_1) + a \left(\frac{1}{v_1} - \frac{1}{v_2} \right)$$

Solution (a) From the energy Eq. (11.13)

$$\left(\frac{\partial U}{\partial V} \right)_T = T \left(\frac{\partial p}{\partial T} \right)_V - p$$

$$\frac{\partial^2 U}{\partial V \cdot \partial T} = T \left(\frac{\partial^2 p}{\partial T^2} \right)_V + \left(\frac{\partial p}{\partial T} \right)_V - \left(\frac{\partial p}{\partial T} \right)_V$$

$$\frac{\partial^2 U}{\partial V \cdot \partial T} = T \left(\frac{\partial^2 p}{\partial T^2} \right)_V$$

$$c_v = \left(\frac{\partial U}{\partial T} \right)_V$$

$$\left(\frac{\partial c_v}{\partial V} \right)_T = \frac{\partial^2 U}{\partial V \cdot \partial T} = T \left(\frac{\partial^2 p}{\partial T^2} \right)_V = \left(\frac{\partial c_v}{\partial v} \right)_T$$

For a van der Waals' gas

$$\left(p + \frac{a}{v^2} \right) (v - b) = RT$$

$$p = \frac{RT}{v-b} - \frac{a}{v^2}$$

$$\therefore \left(\frac{\partial^2 p}{\partial T^2} \right)_V = 0$$

$$\therefore \left(\frac{\partial c_v}{\partial v} \right)_T = 0$$

Proved (a)

$\therefore c_v$ is independent of volume.

(b) From the first Tds Eq. (11.8)

$$Tds = c_v dT + T \left(\frac{\partial p}{\partial T} \right)_V dv$$

and energy Eq. (11.13) $\left(\frac{\partial U}{\partial V} \right)_T = T \left(\frac{\partial p}{\partial T} \right)_V - p$

$$ds = c_v \frac{dT}{T} + \frac{1}{T} \left[p + \left(\frac{\partial U}{\partial V} \right)_T \right] dv$$

For van der Waals' gas

$$\left(\frac{\partial U}{\partial V}\right)_T = \frac{a}{v^2}$$

$$\begin{aligned}\therefore ds &= c_v \frac{dT}{T} + \frac{1}{T} \left(p + \frac{a}{v^2} \right) dv \\ &= c_v \frac{dT}{T} + \frac{R}{v-b} dv\end{aligned}$$

$$\therefore (s_2 - s_1)_T = R \ln \frac{v_2 - b}{v_1 - b} \quad \text{Proved (b)}$$

(c) At constant entropy

$$c_v \frac{dT}{T} + \frac{R}{v-b} dv = 0$$

or
$$\frac{dT}{T} + \frac{R}{c_v} \frac{dv}{v-b} = 0$$

by integration, $T(v-b)^{R/c_v} = \text{constant}$

Proved (c)

$$\begin{aligned}\text{(d)} \quad c_p - c_v &= T \left(\frac{\partial p}{\partial T} \right)_v \left(\frac{\partial v}{\partial T} \right)_p \\ &= \left[\left(\frac{\partial U}{\partial V} \right)_v + p \right] \left(\frac{\partial v}{\partial T} \right)_p \\ &= \left(\frac{a}{v^2} + p \right) \left(\frac{\partial v}{\partial T} \right)_p \\ &= \left(\frac{RT}{v-b} \right) \left(\frac{\partial v}{\partial T} \right)_p\end{aligned}$$

From the equation

$$\left(p + \frac{a}{v^2} \right) (v-b) = RT$$

$$\begin{aligned}\therefore (v-b) (-2av^{-3}) \left(\frac{\partial v}{\partial T} \right)_p + \left(p + \frac{a}{v^2} \right) \left(\frac{\partial v}{\partial T} \right)_p &= R \\ \left(\frac{\partial v}{\partial T} \right)_p &= \frac{R/(v-b)}{\frac{RT}{(v-b)} - \frac{2a}{v^3}}\end{aligned}$$

$$\therefore c_p - c_v = \frac{R}{1 - 2a(v-b)^2/RTv^3} \quad \text{Proved (d)}$$

$$\text{(e)} \quad \left(\frac{\partial U}{\partial V} \right)_T = T \left(\frac{\partial p}{\partial T} \right)_v - p = \frac{a}{v^2}$$

$$du_T = \frac{a}{v^2} dv_T$$

$$\therefore (u_2 - u_1)_T = a \left(\frac{1}{v_1} - \frac{1}{v_2} \right)$$

$$\therefore (h_2 - h_1)_T = (p_2 v_2 - p_1 v_1) + a \left(\frac{1}{v_1} - \frac{1}{v_2} \right) \quad \text{Proved (e)}$$

Example 11.8 The virial equation of state of a gas is given by

$$pv = RT(1 + B'p + C'p^2 + \dots)$$

Show that

$$\lim_{p \rightarrow 0} \left[T \left(\frac{\partial v}{\partial T} \right)_p - v \right] = RT^2 \frac{dB'}{dT}$$

Hence, prove that the inversion temperature of a van der Waals' gas is twice the Boyle temperature.

Solution

$$pv = RT(1 + B'p + C'p^2 + \dots)$$

$$v = \frac{RT}{p} + RTB' + RTpC' + \dots$$

$$\left(\frac{\partial v}{\partial T} \right)_p = \frac{R}{p} + RT \frac{dB'}{dT} + RB' + RTp \frac{dC'}{dT} + R p C' + \dots$$

$$\therefore T \left(\frac{\partial v}{\partial T} \right)_p = \frac{RT}{p} + RT^2 \frac{dB'}{dT} + RTB' + RT^2 p \frac{dC'}{dT} + RT p C' + \dots$$

$$\therefore T \left(\frac{\partial v}{\partial T} \right)_p - v = RT^2 \frac{dB'}{dT} + RT^2 p \frac{dC'}{dT} + \dots$$

$$\mu_J = \frac{1}{c_p} \left[T \left(\frac{\partial v}{\partial T} \right)_p - v \right]$$

$$\therefore = \frac{RT^2}{c_p} \left[\frac{dB'}{dT} + p \frac{dC'}{dT} + \dots \right]$$

$$\therefore \lim_{p \rightarrow 0} \mu_J = \frac{RT^2}{c_p} \frac{dB'}{dT}$$

$$\text{or} \quad \lim_{p \rightarrow 0} \left[T \left(\frac{dv}{dT} \right)_p - v \right] = RT^2 \frac{dB'}{dT} \quad \text{Proved}$$

For a van der Waals' gas, to find Boyle temperature T_B ,

$$B = b - \frac{a}{RT} = 0$$

$$\begin{aligned} \therefore T_B &= \frac{a}{bR} \\ B' &= \frac{B}{RT} = \frac{b}{RT} - \frac{a}{R^2 T^2} \\ \frac{dB'}{dT} &= -\frac{b}{RT^2} + \frac{2a}{R^2 T^3} \\ \therefore \lim_{p \rightarrow 0} \mu_1 &= \frac{RT^2}{c_p} \left(-\frac{b}{RT^2} + \frac{2a}{R^2 T^3} \right) = 0 \\ \therefore \frac{b}{RT^2} &= \frac{2a}{R^2 T^3} \\ \therefore T_i &= \frac{2a}{bR} \\ \therefore T_1 &= 2T_B \end{aligned}$$

or Inversion temperature = $2 \times$ Boyle temperature

Proved

Example 11.9 Over a certain range of pressures and temperatures, the equation of a certain substance is given by the relation

$$v = \frac{RT}{p} - \frac{C}{T^3}$$

where C is a constant. Derive an expression for: (a) the change of enthalpy and (b) the change of entropy, of this substance in an isothermal process.

Solution (a) From Eq. (11.15)

$$dh = c_p dT + \left[v - T \left(\frac{\partial v}{\partial T} \right)_p \right] dp$$

$$\therefore (h_2 - h_1)_T = \int_1^2 \left[v - T \left(\frac{\partial v}{\partial T} \right)_p \right] dp$$

Now,

$$v = \frac{RT}{p} - \frac{C}{T^3}$$

$$\left(\frac{\partial v}{\partial T} \right)_p = \frac{R}{p} + \frac{3C}{T^4}$$

$$\therefore T \left(\frac{\partial v}{\partial T} \right)_p = \frac{RT}{p} + \frac{3C}{T^3}$$

$$\therefore v - T \left(\frac{\partial v}{\partial T} \right)_p = \frac{RT}{p} - \frac{C}{T^3} - \frac{RT}{p} - \frac{3C}{T^3}$$

$$= -\frac{4C}{T^3}$$

On substitution,

$$\begin{aligned}(h_2 - h_1)_T &= \int_{p_1}^{p_2} -\frac{4C}{T^3} dp \\ &= \frac{4C}{T^3} (p_1 - p_2)_T\end{aligned}$$

(b) Using second Tds equation

$$Tds = c_p dT - T \left(\frac{\partial v}{\partial T} \right)_p dp$$

$$\begin{aligned}\therefore ds_T &= - \left(\frac{\partial v}{\partial T} \right)_p dp_T \\ &= - \left(\frac{R}{p} + \frac{3C}{T^4} \right) dp_T\end{aligned}$$

$$\therefore (s_2 - s_1)_T = R \ln \frac{p_1}{p_2} + \frac{3C}{T^4} (p_1 - p_2)_T$$

Example 11.10 Argon gas is compressed reversibly and isothermally at the rate of 1.5 kg/s from 1 atm, 300 K to 400 atm. Calculate the power required to run the compressor and the rate at which heat must be removed from the compressor. The gas is assumed to obey the Redlich-Kwong equation of state, for which the constants are:

$$a = 0.42748 \frac{\bar{R}^2 T_c^{2.5}}{P_c} \quad \text{and} \quad b = 0.08664 \frac{\bar{R}^2 T_c}{P_c}$$

For argon, $T_c = 151$ K and $p_c = 48$ atm. Take $\bar{R} = 0.082$ litre-atm/gmol-K.

Solution Substituting the values of p_c , T_c and R ,

$$a = 0.42748 \frac{(82)^2 (151)^{2.5}}{48} = 16.8 \times 10^6 \frac{\text{atm K}^{1/2} \text{cm}^6}{(\text{gmol})^2}$$

$$b = 0.08664 \frac{(82)(151)}{48} = 22.4 \frac{\text{cm}^3}{\text{gmol}}$$

Substituting the numerical values of p_2 , T_2 , a , b and R into the Redlich-Kwong equation

$$\begin{aligned}p &= \frac{RT}{v-b} - \frac{a}{T^{1/2} v(v+b)} \\ v_2^3 - 49.24 v_2^2 + 335.6 v_2 - 43,440 &= 0\end{aligned}$$

from which we obtain

$$v_2 = 56.8 \text{ cm}^3/\text{gmol}$$

Since $p_1 = 1 \text{ atm}$, the volume of the gas at the initial state can be obtained from the ideal gas equation:

$$v_1 = \frac{RT_1}{p_1} = \frac{82 \times 300}{1} = 24,600 \text{ cm}^3/\text{gmol}$$

For isothermal compression,

$$\Delta h_{12} = h_2 - h_1 = \left\{ \int_{p_1}^{p_2} \left[v - T \left(\frac{\partial v}{\partial T} \right)_p \right] dp \right\}_T$$

Now, $d(pv) = p dv + v dp$

$$\int_{p_1}^{p_2} v dp = p_2 v_2 - p_1 v_1 - \left[\int_{v_1}^{v_2} p dv \right]_T$$

Since $\left(\frac{\partial v}{\partial T} \right)_p = - \left(\frac{\partial v}{\partial p} \right)_T \left(\frac{\partial p}{\partial T} \right)_v$

we have

$$\left[\int_{p_1}^{p_2} \left(\frac{\partial v}{\partial T} \right)_p dp \right]_T = - \left[\int_{v_1}^{v_2} \left(\frac{\partial p}{\partial T} \right)_v dv \right]_T$$

Hence,

$$\Delta h_{12} = h_2 - h_1 = p_2 v_2 - p_1 v_1 - \left\{ \int_{v_1}^{v_2} \left[p - T \left(\frac{\partial p}{\partial T} \right)_v \right] dv \right\}_T$$

According to Redlich-Kwong equation, we have,

$$\left(\frac{\partial p}{\partial T} \right)_v = \frac{R}{v-b} + \frac{a}{2T^{3/2}v(v+b)}$$

Thus,

$$\begin{aligned} \Delta h_{12} &= h_2 - h_1 = (p_2 v_2 - p_1 v_1) - \left\{ \int_{v_1}^{v_2} \left[\frac{-3a}{2T^{1/2}v(v+b)} \right] dv \right\}_T \\ &= (p_2 v_2 - p_1 v_1) - \frac{1.5a}{T_1^{1/2}} \frac{1}{b} \ln \frac{(v_2 + b)/v_2}{(v_1 + b)/v_1} \end{aligned}$$

Substituting the numerical values,

$$h_2 - h_1 = -1,790 \text{ J/gmol}$$

$$\Delta s_{12} = s_2 - s_1 = \left[\int_{p_1}^{p_2} \left(\frac{\partial v}{\partial T} \right)_p dp \right]_T = \left[\int_{v_1}^{v_2} \left(\frac{\partial p}{\partial T} \right)_v dv \right]_T$$

For the Redlich-Kwong equation this becomes,

$$s_2 - s_1 = \left\{ \int_{v_1}^{v_2} \left[\frac{R}{v-b} + \frac{a}{2T^{3/2}v(v+b)} \right] dv \right\}_T$$

$$= R \ln \frac{v_2 - b}{v_1 - b} - \frac{a}{2bT_1^{3/2}} \ln \frac{(v_2 + b)/v_2}{(v_1 + b)/v_1}$$

Substituting the numerical values,

$$s_2 - s_1 = -57 \text{ J/gmol-K}$$

$$\dot{Q}_{12} = \dot{m} T_1 (s_2 - s_1)$$

$$= \frac{10^5 \text{ g/h}}{39.8 \text{ g/gmol}} \times 300 \text{ K} \times (-57) \frac{\text{J}}{\text{g mol K}}$$

$$= -4.29 \times 10^7 \text{ J/h}$$

$$= -11.917 \text{ kW (heat removed from the gas)} \quad \text{Ans.}$$

$$\dot{W}_{12} = \dot{Q}_{12} + \dot{m}(h_1 - h_2)$$

$$= -4.29 \times 10^7 + \frac{10^5}{39.9} \times 1790$$

$$= -3.84 \times 10^7 \text{ J/h}$$

$$= -10.67 \text{ kW (Work is done on the gas)} \quad \text{Ans.}$$

REVIEW QUESTIONS

- 11.1 What is the condition for exact differential?
- 11.2 Derive Maxwell's equations.
- 11.3 Write down the first and second Tds equations, and derive the expression for the difference in heat capacities, C_p and C_v . What does the expression signify?
- 11.4 Define volume expansivity and isothermal compressibility.
- 11.5 Show that the slope of an isentrope is greater than that of an isotherm on p - v plot. How is it meaningful for estimating the work of compression?
- 11.6 What is the energy equation? How does this equation lead to the derivation of the Stefan-Boltzman law of thermal radiation?
- 11.7 Show that the internal energy and enthalpy of an ideal gas are functions of temperature only.
- 11.8 Why are $dU = C_v dT$ and $dH = C_p dT$ true for an ideal gas in any process, whereas these are true for any other substance only at constant volume and at constant pressure respectively?
- 11.9 Explain Joule-Kelvin effect. What is inversion temperature?
- 11.10 What is Joule-Thomson coefficient? Why is it zero for an ideal gas?
- 11.11 Why does the hydrogen gas need to be precooled before being throttled to get the cooling effect?
- 11.12 Why does the maximum temperature drop occur if the state before throttling lies on the inversion curve?

- 11.13 Why does the Gibbs function remain constant during phase transition?
 11.14 What are the characteristics of the first order phase transition?
 11.15 Write down the representative equation for phase transition. Why does the fusion line for water have negative slope on the p - T diagram?
 11.16 Why is the slope of the sublimation curve at the triple point on the p - T diagram greater than that of the vaporization curve at the same point?
 11.17 Explain how thermodynamic properties are evaluated from an equation of state.
 11.18 Illustrate how enthalpy change and entropy change of a gas can be estimated with the help of an equation of state.
 11.19 State the important thermodynamic criteria which an equation of state should satisfy.
 11.20 Explain how the Boyle temperature is yielded when:

$$\lim_{p \rightarrow 0} (\partial Z / \partial p)_T = 0$$

- 11.21 What is foldback temperature?
 11.22 Show that for an inversion curve $(\partial Z / \partial T)_p = 0$.
 11.23 Define chemical potential of a component in terms of U , H , F and G .
 11.24 What is the use of the Gibbs entropy equation?
 11.25 Explain the significance of the Gibbs-Duhem equation.
 11.26 State the conditions of equilibrium of a heterogeneous system.
 11.27 What do you understand by phase equilibrium?
 11.28 Give the Gibbs phase rule for a nonreactive system. Why is the triple point of a substance nonvariant?
 11.29 What are the four types of equilibrium? What is stable equilibrium?
 11.30 State the conditions of spontaneous change, equilibrium and criterion of stability for: (a) a system having constant U and V (i.e., isolated), and (b) system having constant T and p .
 11.31 What do you understand by neutral and unstable equilibrium?
 11.32 What is metastable equilibrium?
 11.33 Show that for a system to be stable, these conditions are satisfied
 (a) $C_v > 0$ (thermal stability)
 (b) $\left(\frac{\partial p}{\partial V}\right)_T < 0$ (mechanical stability)
 11.34 How is the third law a fundamental law of nature?
 11.35 Explain the phenomenon of adiabatic demagnetisation of a paramagnetic salt.
 11.36 How are temperatures near absolute zero estimated?
 11.37 Give the Fowler-Guggenheim statement of third law. How is it different from the Nernst-Simon statement of third law? Give the third equivalent statement of the third law.
 11.38 State some physical and chemical facts which substantiate the third law.

PROBLEMS

- 11.1 Derive the following equations

$$(a) U = F - T \left(\frac{\partial F}{\partial T} \right)_V = -T^2 \left(\frac{\partial F/T}{\partial T} \right)_V$$

$$(b) C_v = -T \left(\frac{\partial^2 F}{\partial T^2} \right)_v$$

$$(c) H = G - T \left(\frac{\partial G}{\partial T} \right)_p = -T^2 \left(\frac{\partial G/T}{\partial T} \right)_p$$

$$(d) C_p = -T \left(\frac{\partial^2 G}{\partial T^2} \right)_p$$

11.2 (a) Derive the equation

$$\left(\frac{\partial c_v}{\partial v} \right)_T = T \left(\frac{\partial^2 p}{\partial T^2} \right)_v$$

(b) Prove that c_v of an ideal gas is a function of T only.

(c) In the case of a gas obeying the equation of state

$$\frac{pv}{RT} = 1 + \frac{B''}{v}$$

where B'' is a function of T only, show that

$$c_v = -\frac{RT}{v} \frac{d^2}{dT^2} (B'' T) + (c_v)_0$$

where $(c_v)_0$ is the value at very large volumes.

11.3 Derive the third TdS equation

$$TdS = C_v \left(\frac{\partial T}{\partial p} \right)_v dp + C_p \left(\frac{\partial T}{\partial V} \right)_p dV$$

and show that the three TdS equations may be written as

$$(a) TdS = C_v dT + \frac{\beta T}{k} dV$$

$$(b) TdS = C_p dT - v\beta T dp$$

$$(c) TdS = \frac{C_v}{\beta} k dp + \frac{C_v}{\beta V} dV$$

11.4 Derive the equations

$$(a) C_p = T \left(\frac{\partial V}{\partial T} \right)_p \left(\frac{\partial p}{\partial T} \right)_s$$

$$(b) \left(\frac{\partial p}{\partial T} \right)_s = \frac{C_p}{v\beta T}$$

$$(c) \frac{(\partial p/\partial T)_s}{(\partial p/\partial T)_v} = \frac{\gamma}{\gamma - 1}$$

11.5 Derive the equations

$$(a) C_v = -T \left(\frac{\partial p}{\partial T} \right)_v \left(\frac{\partial V}{\partial T} \right)_s$$

$$(b) \left(\frac{\partial V}{\partial T} \right)_s = -\frac{C_v k}{\beta T}$$

$$(c) \frac{(\partial V/\partial T)_s}{(\partial V/\partial T)_p} = \frac{1}{1-\gamma}$$

- 11.6 (a) Prove that the slope of a curve on a Mollier diagram representing a reversible isothermal process is equal to

$$T - \frac{1}{\beta}$$

- (b) Prove that the slope of a curve on a Mollier diagram representing a reversible isochoric process is equal to

$$T + \frac{\gamma - 1}{\beta}$$

- 11.7 (a) Show that

$$\mu_J c_p = T^2 \left(\frac{\partial V/T}{\partial T} \right)_p$$

For 1 mole of a gas, in the region of moderate pressures, the equation of state may be written as

$$\frac{p\bar{v}}{RT} = 1 + B'p + C'p^2$$

where B' and C' are functions of temperature only.

- (b) Show that as $p \rightarrow 0$

$$\mu_J c_p \rightarrow \bar{R} T^2 \frac{dB'}{dT}$$

- (c) Show that the equation of the inversion curve is

$$p = - \frac{dB'/dT}{dC'/dT}$$

- 11.8 Prove the following functional relationship of the reduced properties for the inversion curve of a van der Waals' gas

$$T_r = \frac{3(3v_r - 1)^2}{4v_r^2} \quad \text{and} \quad p_r = \frac{9(2v_r - 1)}{v_r^2}$$

Hence, show that

$$\frac{\text{Maximum inversion temperature}}{\text{Critical temperature}} = 6.75$$

and
$$\frac{\text{Minimum inversion temperature}}{\text{Critical temperature}} = 0.75$$

- 11.9 Estimate the maximum inversion temperature of hydrogen if it is assumed to obey the equation of state

$$pV = RT + B_1 p + B_2 p^2 + B_3 p^3 + \dots$$

For hydrogen, $B_1 \times 10^5 = a + 10^{-2} bT + 10^2 c/T$

where $a = 166$, $b = -7.66$, $c = -172.33$

- 11.10 The vapour pressure of mercury at 399 K and 401 K is found to be 0.988 mm and 1.084 mm of mercury respectively. Calculate the latent heat of vaporization of liquid mercury at 400 K.

Ans. 61,634.96 kJ/kg mol

- 11.11 In the vicinity of the triple point, the vapour pressure of liquid ammonia (in atmospheres) is represented by

$$\ln p = 15.16 - \frac{3063}{T}$$

This is the equation of the liquid-vapour boundary curve in a p - T diagram. Similarly, the vapour pressure of solid ammonia is

$$\ln p = 18.70 - \frac{3754}{T}$$

- (a) What is the temperature and pressure at the triple point?
 (b) What are the latent heats of sublimation and vaporization?
 (c) What is the latent heat of fusion at the triple point?

Ans. 195.2 K, 0.585 atm., 1498 kJ/kg, 1836 kJ/kg, 338 kJ/kg

- 11.12 It is found that a certain liquid boils at a temperature of 95°C at the top of a hill, whereas it boils at a temperature of 105°C at the bottom. The latent heat is 4.187 kJ/g mole. What is the approximate height of the hill? Assume $T_0 = 300$ K.

Ans. 394 m

- 11.13 Show that for an ideal gas in a mixture of ideal gases

$$d\mu_k = \frac{\mu_k - h_k}{T} dT + v_k dp + RT d \ln x_k$$

- 11.14 Compute μ_j for a gas whose equation of state is

$$p(v - b) = RT$$

Ans. $\mu_j = -b/c_p$

- 11.15 Show that

$$(a) \left(\frac{\partial \beta}{\partial p} \right)_T = - \left(\frac{\partial k}{\partial T} \right)_p$$

$$(b) \left(\frac{\partial u}{\partial p} \right)_T = -T \left(\frac{\partial v}{\partial p} \right)_p - p \left(\frac{\partial v}{\partial p} \right)_T$$

- 11.16 Two particular systems have the following equations of state

$$\frac{1}{T^{(1)}} = \frac{3}{2} \bar{R} \frac{N^{(1)}}{U^{(1)}} \quad \text{and} \quad \frac{1}{T^{(2)}} = \frac{5}{2} \bar{R} \frac{N^{(2)}}{U^{(2)}}$$

where $\bar{R} = 8.3143$ kJ/kg mol K. The mole number of the first system is $N^{(1)} = 2$, and that of the second is $N^{(2)} = 3$. The two systems are separated by a diathermal wall, and the total energy in the composite system is 25.120 kJ. What is the internal energy of each system in equilibrium?

Ans. 7.2 kJ, 17.92 kJ

- 11.17 Two systems with the equations of state given in Problem 11.16 are separated by a diathermal wall. The respective mole numbers are $N^{(1)} = 2$ and $N^{(2)} = 3$. The initial temperatures are $T^{(1)} = 250$ K and $T^{(2)} = 350$ K. What are the values of $U^{(1)}$ and $U^{(2)}$ after equilibrium has been established? What is the equilibrium temperature?

Ans. 8.02 kJ, 20.04 kJ, 321.4 K

- 11.18 Show that the change in latent heat L with temperature is given by the following relation

$$\left(\frac{dL}{dT}\right) = (C_p''' - C_p'') + \frac{L}{T} - \frac{v'''\beta''' - v''\beta''}{v''' - v''} L$$

11.19 Show that for a van der Waals' gas, the Joule-Thomson coefficient is given by

$$\mu_j = \frac{v}{c_p} \left[\frac{2a(v-b)^2 - RTbv^2}{RTv^3 - 2a(v-b)^2} \right]$$

11.20 At 273.15 K the specific volumes of water and ice are 0.001 and 0.001091 m³/kg and the latent heat of fusion of ice is 334 kJ/kg. Determine the melting point increase due to increase of pressure by 1 atm (101.325 kPa).

Ans. - 0.00753 K

11.21 Calculate the latent heat of vaporization of steam formed by boiling water under a pressure of 101.325 kPa. At a pressure near this, a rise of temperature of 1 K causes an increase of vapour pressure of 3.62 kPa.

Ans. 2257 kJ/kg

11.22 It is known that radiation exerts a pressure $p = 1/3 u$, where u is the energy per unit volume.

(a) Show that

$$du = Tds + \frac{1}{V} \left(Ts - \frac{4}{3} u \right) dV$$

where s is the entropy per unit volume.

(b) Assuming u and s as functions of temperature only, show that

$$(i) \quad u = As^{4/3}$$

$$(ii) \quad s = \frac{4}{3} aT^3$$

$$(iii) \quad u = aT^4$$

where A is the constant of integration and $a = 81/256 A^3$.

(c) Show that the average time radiation remains in a spherical enclosure of radius r is given by

$$t = \frac{4r}{3c}$$

where c is the speed of radiation.

(d) If E_B is the energy emitted per unit area of spherical surface per unit time, show that

$$E_B = \sigma T^4$$

where $\sigma = ac/4$ and T is the temperature of the surface.

11.23 Show that the inversion temperature of a van der Waals' gas is given by $T_1 = 2a/bR$.

11.24 Show that:

$$(a) \quad \left(\frac{\partial u}{\partial v}\right)_T = T^2 \left(\frac{\partial(p/T)}{\partial T}\right)_v$$

$$(b) \quad \left(\frac{\partial h}{\partial p}\right)_T = -T^2 \left(\frac{\partial(v/T)}{\partial T}\right)_p$$

11.25 Show that for a van der Waals' gas at low pressures, a Joule-Thomson expansion from pressure p_1 to p_2 produces a temperature change which can be found from the solution of

$$p_1 - p_2 = \frac{c_p}{b}(T_1 - T_2) + T_i \ln \frac{T_2 - T_i}{T_1 - T_i}$$

where T_i is the inversion temperature.

- 11.26 Using the Redlich-Kwong equation of state, develop expressions for the changes in entropy and internal energy of a gas in an isothermal process.

$$\text{Ans. } (s_2 - s_1)_T = R \ln \frac{v_2 - b}{v_1 - b} + \frac{a}{2bT^{3/2}} \ln \left[\frac{v_2(v_1 + b)}{v_1(v_2 + b)} \right]$$

$$(u_2 - u_1)_T = \frac{a}{2bT^{1/2}} \ln \left[\frac{v_2(v_1 + b)}{v_1(v_2 + b)} \right]$$

- 11.27 Find the change of entropy of a gas following Clausius equation of state at constant temperature

$$p(v - b) = RT$$

$$\text{Ans. } R \ln \frac{v_2 - b}{v_1 - b}$$

- 11.28 (a) Show that for a van der Waals' gas

$$\beta = \frac{Rv^2(v - b)}{RTv^3 - 2a(v - b)^2}$$

$$k_T = \frac{v^2(v - b)^2}{RTv^3 - 2a(v - b)^2}$$

(b) What is the value of k_T/β expressed in its simplest form?

(c) What do the above relations become when $a = 0$, $b = 0$ (ideal gas)?

- 11.29 (a) Show that

$$(i) \left(\frac{\partial u}{\partial p} \right)_v = \frac{k}{\beta} \cdot c_v$$

$$(ii) \left(\frac{\partial u}{\partial v} \right)_p = \frac{c_p}{v\beta} - p$$

(b) Hence show that the slope of a reversible adiabatic process on $p-v$ coordinates is

$$\frac{dp}{dv} = - \frac{\gamma}{kv}$$

where k is the isothermal compressibility.

- 11.30 According to Berthelot, the temperature effect of the second virial coefficient is given by

$$B'(T) = \frac{b}{T} - \frac{a}{T^3}$$

where a and b are constants. Show that according to Berthelot,

$$T_{inv}/T_B = \sqrt{3}$$

- 11.31 The following expressions for the equation of state and the specific heat c_p are obeyed by a certain gas:

$$v = \frac{RT}{p} + \alpha T^2 \text{ and } c_p = A + BT + Cp$$

where α, A, B, C are constants. Obtain an expression for (a) the Joule-Thomson coefficient, and (b) the specific heat c_v .

$$\text{Ans. (a) } \mu_J = \frac{\alpha T^2}{A + BT + Cp} \quad \text{(b) } C_v = A + BT + \frac{CRT}{v - \alpha T^2} - R \left(\frac{v + \alpha T^2}{v - \alpha T^2} \right)$$

- 11.32 Determine the maximum Joule-Thomson inversion temperature in terms of the critical temperature T_c predicted by the
 (a) van der Waals equation
 (b) Redlich-Kwong equation
 (c) Dieterici equation

$$\text{Ans. (a) } 6.75 T_c, \quad \text{(b) } 5.34 T_c \quad \text{(c) } 8T_c$$

- 11.33 From the virial form of the equation of state of a gas

$$v = \frac{RT}{p} + RTB'(T) + RTC'(T)p + \dots$$

show that the Joule-Thomson coefficient is

$$\mu_J = \frac{RT^2}{c_p} \left[\frac{dB'}{dT} + \frac{dC'}{dT} p + \dots \right]$$

- (b) For a van der Waals gas

$$B'(T) = \frac{bRT - a}{R^2 T^2}$$

Show that the limiting value of μ_J at low pressures is

$$\mu_J = \frac{1}{c_p} \left(\frac{2a}{RT} - b \right)$$

- 11.34 Show that $k_T - k_s = \frac{Tv\beta^2}{c_p}$

- 11.35 For a simple compressible system, show that

$$\text{(a) } \left[\frac{\partial u}{\partial v} \right]_T = T^2 \left[\frac{\partial p/T}{\partial T} \right]_v$$

$$\text{(b) } \left[\frac{\partial h}{\partial p} \right]_T = -T^2 \left[\frac{\partial v/T}{\partial T} \right]_p$$

- 11.36 The liquid-vapour equilibrium curve for nitrogen over the range from the triple point to the normal boiling point may be expressed by the relation:

$$\log p = A - BT - \frac{C}{T}$$

where p is the vapour pressure in mm Hg, T is the temperature in K, and $A = 7.782$, $B = 0.006265$, and $C = 341.6$.

- (a) Derive an expression for the enthalpy of vaporization h_{fg} in terms of A, B, C, T and v_{fg} .
 (b) Calculate h_{fg} for nitrogen at 71.9 K with $v_{fg} = 11,530 \text{ cm}^3/\text{gmol}$.

$$\text{Ans. } 5,790 \text{ J/gmol}$$

- 11.37 For a gas obeying the van der Waals equation of state, show that:

$$\text{(a) } c_p - c_v = \frac{R}{1 - 2a(v-b)^2/RTv^3}$$

$$(b) \left[\frac{\partial c_v}{\partial v} \right]_T = T \left[\frac{\partial^2 p}{\partial T^2} \right]_v = 0 \text{ to prove that } c_v \text{ is a function of temperature only.}$$

$$(c) \left[\frac{\partial c_p}{\partial p} \right]_T = -T \left[\frac{\partial^2 v}{\partial T^2} \right]_p \\ = R^2 T \left[\frac{2av^{-3} - 6abv^{-4}}{(p - av^{-2} + 2abv^{-3})^3} \right]$$

to prove that c_p for a van der Waals gas is not a function of temperature only.

(d) The relation between T and v is given by:

$$T(v - b)^{R/c_v} = \text{constant}$$

(e) The relation between p and v is given by:

$$\left[p + \frac{a}{v^2} \right] (v - b)^{1 + R/c_v} = \text{constant.}$$

- 11.38 Nitrogen at a pressure of 250 atm and a temperature of 400 K expands reversibly and adiabatically in a turbine to an exhaust pressure of 5 atm. The flow rate is 1 kg/s. Calculate the power output if nitrogen obeys the Redlich-Kwong equation of state. For nitrogen at 1 atm take,

$$c_p = 6.903 - 0.3753 \times 10^{-3} T + 1.930 \times 10^{-6} T^2 - 6.861 \times 10^{-9} T^3$$

where c_p is in cal/gmol-K and T is in K.

For nitrogen, $T_c = 126.2$ K,

$$p_c = 33.5 \text{ atm.}$$

Ans. 272 kW

Hints: See Fig. P-11.34

$$h_1 - h_2 = (h_1 - h_4) + (h_4 - h_3) + (h_3 - h_2) \text{ and}$$

$$s_1 - s_2 = 0 = (s_1 - s_4) + (s_4 - s_3) + (s_3 - s_2)$$

$$a = 15.4 \times 10^6 \text{ atm/K}^{1/2} \text{ cm}^6/(\text{gmol})^2, b = 26.8 \text{ cm}^3/\text{gmol}$$

By trial-and-error, $v_1 = 143 \text{ cm}^3/\text{gmol}$, $v_4 = 32,800 \text{ cm}^3/\text{gmol}$

$$T_2 = 124 \text{ K}, h_1 - h_2 = 7.61 \text{ kJ/gmol.}$$

Vapour Power Cycles

12.1 Simple Steam Power Cycle

A power cycle continuously converts heat (energy released by the burning of fuel) into work (shaft work), in which a working fluid repeatedly performs a succession of processes. In the vapour power cycle, the working fluid, which is water, undergoes a change of phase. Figure 12.1 gives the schematic of a simple steam power plant working on the vapour power cycle. Heat is transferred to water in the boiler from an external source (furnace, where fuel is continuously burnt) to raise steam, the high pressure, high temperature steam leaving the boiler expands in the turbine to produce shaft work, the steam leaving the turbine condenses into water in the condenser (where cooling water circulates), rejecting

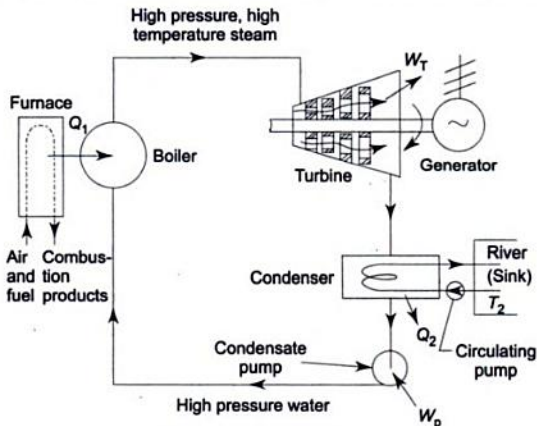

Fig. 12.1 Simple steam power plant

heat, and then the water is pumped back to the boiler. Figure 12.2 shows how a unit mass of the working fluid, sometimes in the liquid phase and sometimes in the vapour phase, undergoes various external heat and work interactions in executing a power cycle. Since the fluid is undergoing a cyclic process, there will be no net change in its internal energy over the cycle, and consequently the net energy transferred to the unit mass of the fluid as heat during the cycle must equal the net energy transfer as work from the fluid. Figure 12.3 shows the cyclic heat engine operating on the vapour power cycle, where the working substance, water, follows along the B-T-C-P(Boiler-Turbine-Condenser-Pump) path, interacting

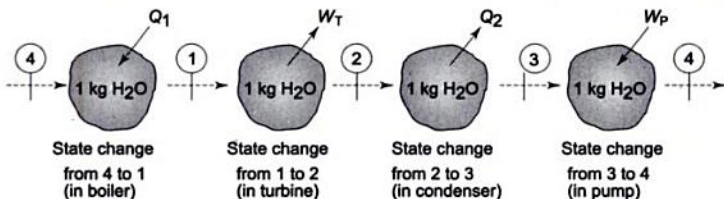

Fig. 12.2 One kg H_2O executing a heat engine cycle

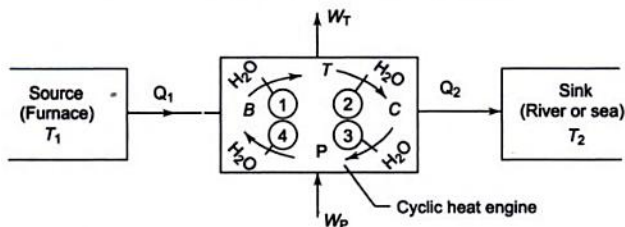

Fig. 12.3 Cyclic heat engine with water as the working fluid

externally as shown, and converting net heat input to net work output continuously. By the first law

$$\sum_{\text{cycle}} Q_{\text{net}} = \sum_{\text{cycle}} W_{\text{net}}$$

or

$$Q_1 - Q_2 = W_T - W_P$$

where Q_1 = heat transferred to the working fluid (kJ/kg)

Q_2 = heat rejected from the working fluid (kJ/kg)

W_T = work transferred from the working fluid (kJ/kg)

W_P = work transferred into the working fluid (kJ/kg)

The efficiency of the vapour power cycle would be given by

$$\begin{aligned} \eta_{\text{cycle}} &= \frac{W_{\text{net}}}{Q_1} = \frac{W_T - W_P}{Q_1} = \frac{Q_1 - Q_2}{Q_1} \\ &= 1 - \frac{Q_2}{Q_1} \end{aligned} \quad (12.1)$$

12.2 Rankine Cycle

For each process in the vapour power cycle, it is possible to assume a hypothetical or ideal process which represents the basic intended operation and involves no extraneous effects. For the steam boiler, this would be a reversible constant pressure heating process of water to form steam, for the turbine the ideal process would be a reversible adiabatic expansion of steam, for the condenser it would be a reversible constant pressure heat rejection as the steam condenses till it becomes saturated liquid, and for the pump, the ideal process would be the reversible adiabatic compression of this liquid ending at the initial pressure. When all these four processes are ideal, the cycle is an ideal cycle, called a *Rankine cycle*. This is a reversible cycle. Figure 12.4 shows the flow diagram of the Rankine cycle, and in Fig. 12.5, the cycle has been plotted on the p - v , T - s , and h - s planes. The numbers on the plots correspond to the numbers on the flow diagram. For any given pressure, the steam approaching the turbine may be dry saturated (state 1) wet (state 1'), or superheated (state 1''), but the fluid approaching the pump is, in each case, saturated liquid (state 3). Steam expands reversibly and adiabatically in the turbine from state 1 to state 2 (or 1' to 2', or 1'' to 2''), the steam leaving the turbine condenses to water in the condenser reversibly at constant pressure from state 2 (or 2', or 2'') to state 3, the water at state 3 is then pumped to the boiler at state 4 reversibly and adiabatically, and the water is heated in the boiler to form steam reversibly at constant pressure from state 4 to state 1 (or 1' or 1'').

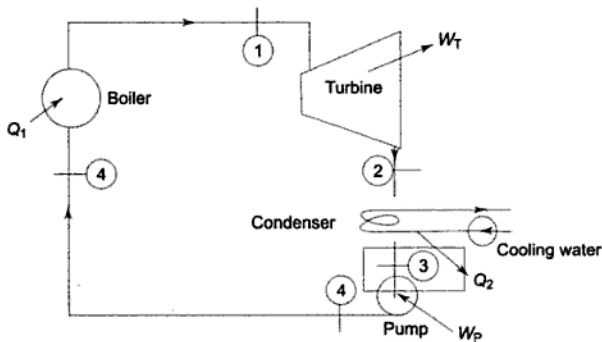

Fig. 12.4 A simple steam plant

For purposes of analysis the Rankine cycle is assumed to be carried out in a steady flow operation. Applying the steady flow energy equation to each of the processes on the basis of unit mass of fluid, and neglecting changes in kinetic and potential energy, the work and heat quantities can be evaluated in terms of the properties of the fluid.

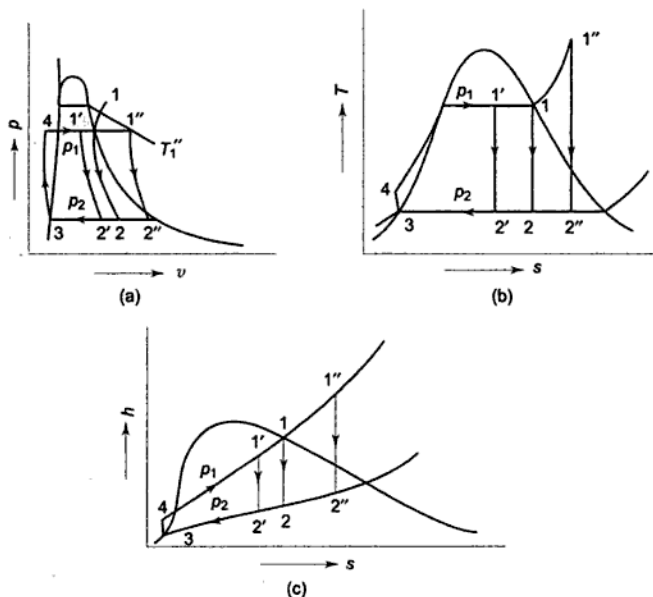

Fig. 12.5 Rankine cycle on p - v , T - s and h - s diagrams

For 1 kg fluid

The S.F.E.E. for the boiler (control volume) gives

$$h_4 + Q_1 = h_1$$

$$\therefore Q_1 = h_1 - h_4 \quad (12.2)$$

The S.F.E.E. for the turbine as the control volume gives

$$h_1 = W_T + h_2$$

$$\therefore W_T = h_1 - h_2 \quad (12.3)$$

Similarly, the S.F.E.E. for the condenser is

$$h_2 = Q_2 + h_3$$

$$\therefore Q_2 = h_2 - h_3 \quad (12.4)$$

and the S.F.E.E. for the pump gives

$$h_3 + W_P = h_4$$

$$\therefore W_P = h_4 - h_3 \quad (12.5)$$

The efficiency of the Rankine cycle is then given by

$$\eta = \frac{W_{\text{net}}}{Q_1} = \frac{W_T - W_P}{Q_1} = \frac{(h_1 - h_2) - (h_4 - h_3)}{h_1 - h_4} \quad (12.6)$$

The pump handles liquid water which is incompressible, i.e., its density or specific volume undergoes little change with increase in pressure. For reversible adiabatic compression, by the use of the general property relation

$$Tds = dh - vdp; ds = 0$$

and

$$dh = vdp$$

Since change in specific volume is negligible

$$\Delta h = v \Delta p$$

or

$$h_4 - h_3 = v_3 (p_1 - p_2)$$

If v is in m^3/kg and p is in bar

$$h_4 - h_3 = v_3(p_1 - p_2) \times 10^5 \text{ J/kg} \quad (12.7)$$

The *work ratio* is defined as the ratio of net work output to positive work output.

$$\therefore \text{work ratio} = \frac{W_{\text{net}}}{W_T} = \frac{W_T - W_P}{W_T}$$

Usually, the pump work is quite small compared to the turbine work and is sometimes neglected. Then $h_4 = h_3$, and the cycle efficiency approximately becomes

$$\eta \equiv \frac{h_1 - h_2}{h_1 - h_4}$$

The efficiency of the Rankine cycle is presented graphically in the T - s plot in Fig. 12.6. Thus Q_1 is proportional to area 1564, Q_2 is proportional to area 2563, and $W_{\text{net}} (=Q_1 - Q_2)$ is proportional to area 1 2 3 4 enclosed by the cycle.

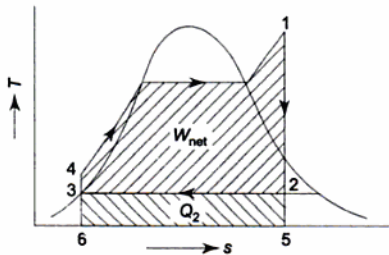

Fig. 12.6 Q_1 , W_{net} and Q_2 are proportional to areas

The capacity of a steam plant is often expressed in terms of *steam rate*, which is defined as the rate of steam flow (kg/h) required to produce unit shaft output (1 kW). Therefore

$$\begin{aligned} \text{Steam rate} &= \frac{1}{W_T - W_P} \frac{\text{kg}}{\text{kJ}} \cdot \frac{1 \text{ kJ/s}}{1 \text{ kW}} \\ &= \frac{1}{W_T - W_P} \frac{\text{kg}}{\text{kWs}} = \frac{3600}{W_T - W_P} \frac{\text{kJ}}{\text{kWh}} \end{aligned} \quad (12.8)$$

The cycle efficiency is sometimes expressed alternatively as *heat rate* which is the rate input (Q_1) required to produce unit work output (1 kW)

$$\text{Heat rate} = \frac{3600 Q_1}{W_T - W_P} = \frac{3600}{\eta_{\text{cycle}}} \frac{\text{kJ}}{\text{kWh}} \quad (12.9)$$

From the equation $W_{\text{rev}} = - \int_1^2 v dp$, it is obvious that the reversible steady-flow work is closely associated with the specific volume of fluid flowing through the device. The larger the specific volume, the larger the reversible work produced or consumed by the steady-flow device. Therefore, every effort should be made to keep the specific volume of a fluid as small as possible during a compression process to minimize the work input and as large as possible, during an expansion process to maximize the work output.

In steam or gas power plants (Chapter 13), the pressure rise in the pump or compressor is equal to the pressure drop in the turbine if we neglect the pressure losses in various other components. In steam power plants, the pump handles liquid, which has a very small specific volume, and the turbine handles vapour, whose specific volume is many times larger. Therefore, the work output of the turbine is much larger than the work input to the pump. This is one of the reasons for the overwhelming popularity of steam power plants in electric power generation.

If we were to compress the steam exiting the turbine back to the turbine inlet pressure before cooling it first in the condenser in order to “save” the heat rejected, we would have to supply all the work produced by the turbine back to the compressor. In reality, the required work input would be still greater than the work output of the turbine because of the irreversibilities present in both processes (see Example 12.1).

12.3 Actual Vapour Cycle Processes

The processes of an actual cycle differ from those of the ideal cycle. In the actual cycle conditions might be as indicated in Figs 12.7 and 12.8, showing the various losses. The thermal efficiency of the cycle is

$$\eta_{\text{th}} = \frac{W_{\text{net}}}{Q_1}$$

where the work and heat quantities are the measured values for the actual cycle, which are different from the corresponding quantities of the ideal cycle.

12.3.1 Piping losses

Pressure drop due to friction and heat loss to the surroundings are the most important piping losses. States 1' and 1 (Fig. 12.8) represent the states of the steam leaving the boiler and entering the turbine respectively, 1' - 1'' represents the frictional losses, and 1''-1 shows the constant pressure heat loss to the

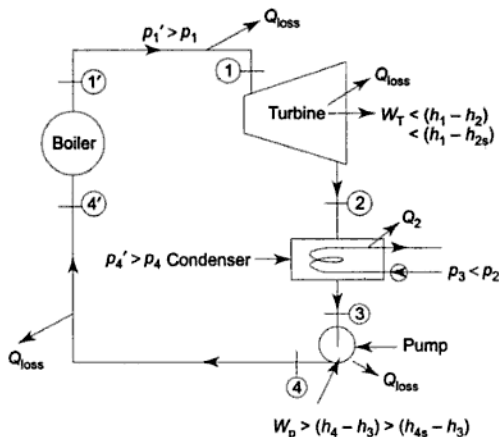

Fig. 12.7 Various losses in a steam plant

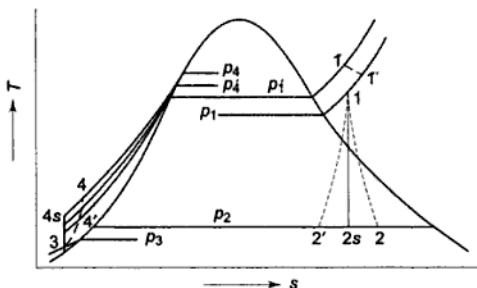

Fig. 12.8 Various losses on T-s plot

surroundings. Both the pressure drop and heat transfer reduce the availability of steam entering the turbine.

A similar loss is the pressure drop in the boiler and also in the pipeline from the pump to the boiler. Due to this pressure drop, the water entering the boiler must be pumped to a much higher pressure than the desired steam pressure leaving the boiler, and requires additional pump work.

12.3.2 Turbine Losses

The losses in the turbine are those associated with frictional effects and heat loss to the surroundings. The steady flow energy equation for the turbine in Fig. 12.7 gives

$$h_1 = h_2 + W_T + Q_{\text{loss}}$$

\therefore

$$W_T = h_1 - h_2 - Q_{\text{loss}} \quad (12.10)$$

For the reversible adiabatic expansion, the path will be 1-2s. For an ordinary real turbine the heat loss is small, and W_T is $h_1 - h_2$, with Q_2 equal to zero. Since

actual turbine work is less than the reversible ideal work output, h_2 is greater than h_{2s} . However, if there is heat loss to the surroundings, h_2 will decrease, accompanied by a decrease in entropy. If the heat loss is large, the end state of steam from the turbine may be $2'$. It may so happen that the entropy increase due to frictional effects just balances the entropy decrease due to heat loss, with the result that the initial and final entropies of steam in the expansion process are equal, *but the expansion is neither adiabatic nor reversible*. Except for very small turbines, heat loss from turbines is generally negligible. The isentropic efficiency of the turbine is defined as

$$\eta_T = \frac{W_T}{h_1 - h_{2s}} = \frac{h_1 - h_2}{h_1 - h_{2s}} \quad (12.11)$$

where W_T is the actual turbine work, and $(h_1 - h_{2s})$ is the isentropic enthalpy drop in the turbine (i.e., ideal output).

12.3.3 Pump Losses

The losses in the pump are similar to those of the turbine, and are primarily due to the irreversibilities associated with fluid friction. Heat transfer is usually negligible. The pump efficiency is defined as

$$\eta_P = \frac{h_{4s} - h_3}{W_P} = \frac{h_{4s} - h_3}{h_4 - h_3} \quad (12.12)$$

where W_P is the actual pump work.

12.3.4 Condenser Losses

The losses in the condenser are usually small. These include the loss of pressure and the cooling of condensate below the saturation temperature.

12.4 Comparison of Rankine and Carnot Cycles

Although the Carnot cycle has the maximum possible efficiency for the given limits of temperature, it is not suitable in steam power plants. Figure 12.9 shows the Rankine and Carnot cycles on the T - s diagram. The reversible adiabatic expansion in the turbine, the constant temperature heat rejection in the condenser, and the reversible adiabatic compression in the pump, are similar characteristic features of both the Rankine and Carnot cycles. But whereas the heat addition process in the Rankine cycle is reversible and at constant pressure, in the Carnot cycle it is reversible and isothermal. In Figs 12.9(a) and 12.9(c), Q_2 is the same in both the cycles, but since Q_1 is more, η_{Carnot} is greater than η_{Rankine} . The two Carnot cycles in Figs 12.9(a) and 12.9(b) have the same thermal efficiency. Therefore, in Fig. 12.9(b) also, $\eta_{\text{Carnot}} > \eta_{\text{Rankine}}$. But the Carnot cycle cannot be realized in practice because the pump work [in all the three cycles (a), (b), and (c)] is very large. Whereas in (a) and (c) it is impossible to add heat at infinite pressures and at constant temperature from state $4c$ to state 1, in (b), it is difficult

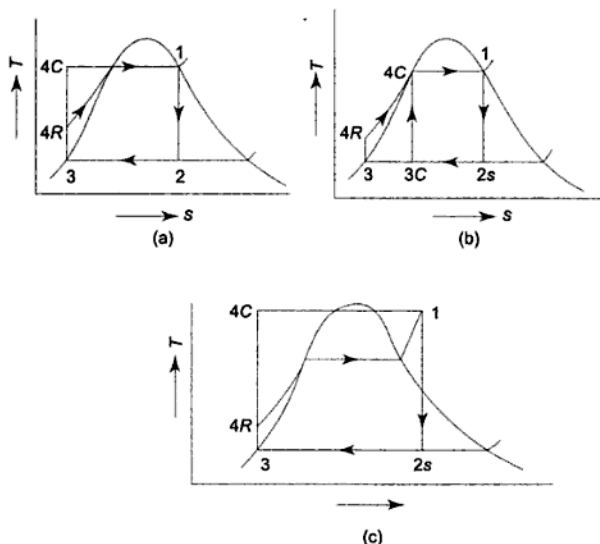

Fig. 12.9 Comparison of Carnot and Rankine cycles

to control the quality at 3c, so that isentropic compression leads to a saturated liquid state.

12.5 Mean Temperature of Heat Addition

In the Rankine cycle, heat is added reversibly at a constant pressure, but at infinite temperatures. If T_{m1} is the mean temperature of heat addition, as shown in Fig. 12.10, so that the area under 4s and 1 is equal to the area under 5 and 6, then heat added

$$Q_1 = h_1 - h_{4s} = T_{m1} (s_1 - s_{4s})$$

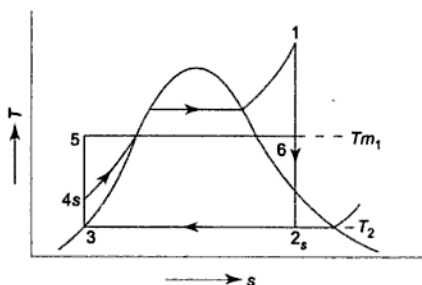

Fig. 12.10 Mean temperature of heat addition

$\therefore T_{m1}$ = Mean temperature of heat addition

$$= \frac{h_1 - h_{4s}}{s_1 - s_{4s}}$$

Since

$$Q_2 = \text{Heat rejected} = h_{2s} - h_3 \\ = T_2 (s_1 - s_{4s})$$

$$\eta_{\text{Rankine}} = 1 - \frac{Q_2}{Q_1} = 1 - \frac{T_2 (s_1 - s_{4s})}{T_{m1} (s_1 - s_{4s})}$$

$$\therefore \eta_{\text{Rankine}} = 1 - \frac{T_2}{T_{m1}} \quad (12.13)$$

where T_2 is the temperature of heat rejection. The lower is the T_2 for a given T_{m1} , the higher will be the efficiency of the Rankine cycle. But the lowest practicable temperature of heat rejection is the temperature of the surroundings (T_0). This being fixed,

$$\eta_{\text{Rankine}} = f(T_{m1}) \text{ only} \quad (12.14)$$

The higher the mean temperature of heat addition, the higher will be the cycle efficiency.

The effect of increasing the initial temperature at constant pressure on cycle efficiency is shown in Fig. 12.11. When the initial state changes from 1 to 1', T_{m1} between 1 and 1' is higher than T_{m1} between 4s and 1. So an increase in the superheat at constant pressure increases the mean temperature of heat addition and hence the cycle efficiency.

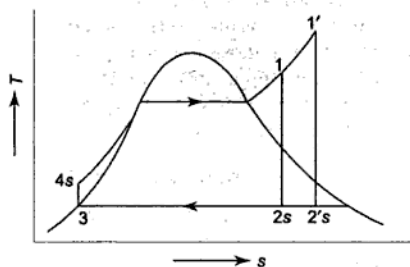

Fig. 12.11 Effect of superheat on mean temperature of heat addition

The maximum temperature of steam that can be used is fixed from metallurgical considerations (i.e., the materials used for the manufacture of the components which are subjected to high-pressure, high-temperature steam like the superheaters, valves, pipelines, inlet stages of turbine, etc.). When the maximum temperature is fixed, as the operating steam pressure at which heat is added in the boiler increases from p_1 to p_2 (Fig. 12.12), the mean temperature of heat addition increases, since T_{m1} between 7s and 5 is higher than that between 4s and 1. But when the turbine inlet pressure increases from p_1 to p_2 , the ideal expan-

sion line shifts to the left and the moisture content at the turbine exhaust increases (because $x_{6s} < x_{2s}$). If the moisture content of steam in the later stages of the turbine is higher, the entrained water particles along with the vapour coming out from the nozzles with high velocity strike the blades and erode their surfaces, as a result of which the longevity of the blades decreases. From a consideration of the erosion of blades in the later stages of the turbine, the maximum moisture content at the turbine exhaust is not allowed to exceed 15%, or the quality to fall below 85%. It is desirable that most of the turbine expansion should take place in the single phase or vapour region.

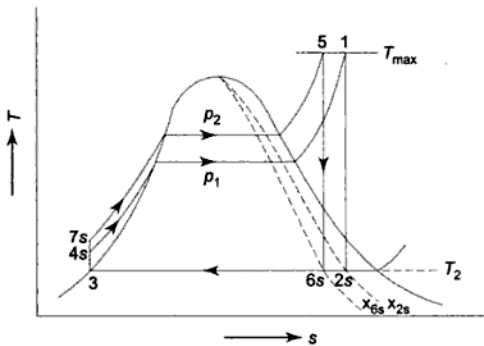

Fig. 12.12 Effect of increase of pressure on Rankine cycle

Therefore, with the maximum steam temperature at the turbine inlet, the minimum temperature of heat rejection, and the minimum quality of steam at the turbine exhaust being fixed, the maximum steam pressure at the turbine inlet also gets fixed (Fig. 12.13). The vertical line drawn from $2s$, fixed by T_2 and x_{2s} , intersects the T_{max} line, fixed by material, at 1, which gives the maximum steam pressure at the turbine inlet. The irreversibility in the expansion process has, however, not been considered.

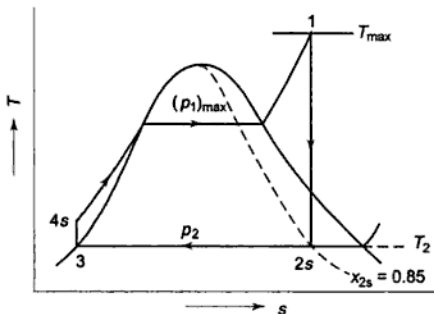

Fig. 12.13 Fixing of exhaust quality, maximum temperature and maximum pressure in Rankine cycle

12.6 Reheat Cycle

If a steam pressure higher than $(p_1)_{\max}$ (Fig. 12.13) is used, in order to limit the quality to 0.85 at the turbine exhaust, reheat has to be adopted. In that case all the steam after partial expansion in the turbine is brought back to the boiler, reheated by combustion gases and then fed back to the turbine for further expansion. The flow, T - s , and h - s diagrams for the ideal Rankine cycle with reheat are shown in Fig. 12.14. In the reheat cycle the expansion of steam from the initial state 1 to the condenser pressure is carried out in two or more steps, depending upon the number of reheats used. In the first step, steam expands in the high pressure (H.P.) turbine from the initial state to approximately the saturated vapour line (process 1-2s in Fig. 12.14). The steam is then resuperheated (or reheated) at constant pressure in the boiler (process 2s-3) and the remaining expansion (process 3-4s) is carried out in the low pressure (L.P.) turbine. In the case of use of two reheats, steam is resuperheated twice at two different constant pressures. To protect the reheater tubes, steam is not allowed to expand deep into the two-phase region before it is taken for reheating, because in that case the moisture particles in steam while evaporating would leave behind solid deposits in the form of scale which is difficult to remove. Also, a low reheat pressure may bring down T_{m1} and hence, cycle efficiency. Again, a high reheat pressure increases the moisture content at turbine exhaust. Thus, the reheat pressure is optimized. The optimum reheat pressure for most of the modern power plants is about 0.2 to 0.25 of the initial steam pressure. For the cycle in Fig. 12.14, for 1 kg of steam

$$\begin{aligned} Q_1 &= h_1 - h_{6s} + h_3 - h_{2s} \\ Q_2 &= h_{4s} - h_5 \\ W_T &= h_1 - h_{2s} + h_3 - h_{4s} \\ W_P &= h_{6s} - h_5 \\ \eta &= \frac{W_T - W_P}{Q_1} = \frac{(h_1 - h_{2s} + h_3 - h_{4s}) - (h_{6s} - h_5)}{h_1 - h_{6s} + h_3 - h_{2s}} \end{aligned} \quad (12.15)$$

$$\text{Steam rate} = \frac{3600}{(h_1 - h_{2s} + h_3 - h_{4s}) - (h_{6s} - h_5)} \text{ kg/kWh} \quad (12.16)$$

where enthalpy is in kJ/kg.

Since higher pressures are used in a reheat cycle, pump work may be appreciable.

Had the high pressure p_1 been used without reheat, the ideal Rankine cycle would have been 1-4's-5-6s. With the use of reheat, the area 2s-3-4s-4's has been added to the basic cycle. It is obvious that net work output of the plant increases with reheat, because $(h_3 - h_{4s})$ is greater than $(h_{2s} - h_{4's})$, and hence the steam rate decreases. Whether the cycle efficiency improves with reheat depends upon whether the mean temperature of heat addition in process 2s-3 is higher than the mean temperature of heat addition in process 6s-1. In practice, the use of reheat only gives a marginal increase in cycle efficiency, but it increases the net work output by making possible the use of higher pressures, keeping the quality

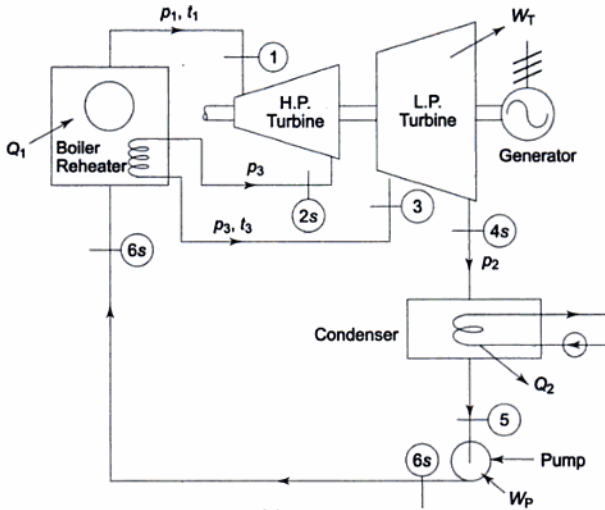

(a)

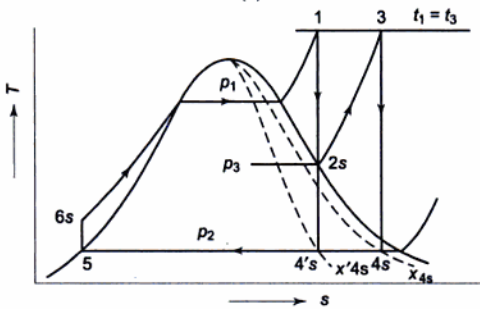

(b)

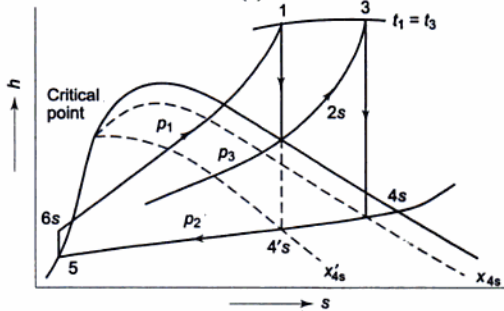

(c)

Fig. 12.14 Reheat cycle

of steam at turbine exhaust within a permissible limit. The quality improves from $x_{4's}$ to x_{4s} by the use of reheat.

By increasing the number of reheats, still higher steam pressures could be used, but the mechanical stresses increase at a higher proportion than the increase in pressure, because of the prevailing high temperature. The cost and fabrication difficulties will also increase. In that way, the maximum steam pressure gets fixed, and more than two reheats have not yet been used so far.

In Fig. 12.14, only ideal processes have been considered. The irreversibilities in the expansion and compression processes have been considered in the example given later.

12.7 Ideal Regenerative Cycle

In order to increase the mean temperature of heat addition (T_{m1}), attention was so far confined to increasing the amount of heat supplied at high temperatures, such as increasing superheat, using higher pressure and temperature of steam, and using reheat. The mean temperature of heat addition can also be increased by decreasing the amount of heat added at low temperatures. In a saturated steam Rankine cycle (Fig. 12.15), a considerable part of the total heat supplied is in the liquid phase when heating up water from 4 to 4', at a temperature lower than T_1 , the maximum temperature of the cycle. For maximum efficiency, all heat should be supplied at T_1 , and feedwater should enter the boiler at state 4'. This may be accomplished in what is known as an ideal regenerative cycle, the flow diagram of which is shown in Fig. 12.16 and the corresponding T - s diagram in Fig. 12.17.

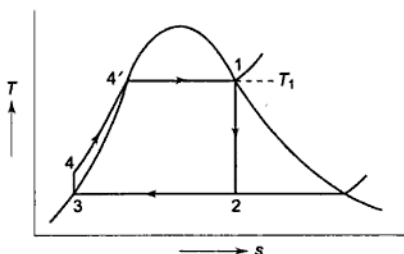

Fig. 12.15 Simple Rankine Cycle

The unique feature of the ideal regenerative cycle is that the condensate, after leaving the pump circulates around the turbine casing, counterflow to the direction of vapour flow in the turbine (Fig. 12.16). Thus, it is possible to transfer heat from the vapour as it flows through the turbine to the liquid flowing around the turbine. Let us assume that this is a reversible heat transfer, i.e., at each point the temperature of the vapour is only infinitesimally higher than the temperature of the liquid. The process 1-2' (Fig. 12.17) thus represents reversible expansion of steam in the turbine with reversible heat rejection. For any small step in the process of heating the water,

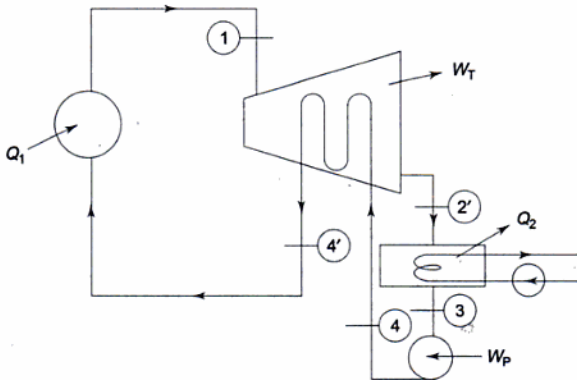

Fig. 12.16 Ideal regenerative cycle-basic scheme

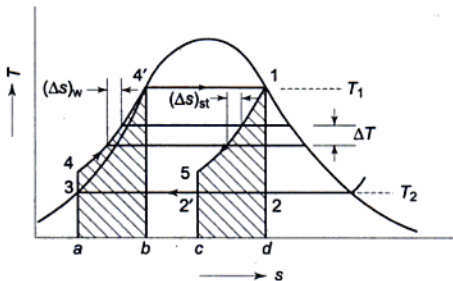

Fig. 12.17 Ideal regenerative cycle on T-s plot

$$\Delta T(\text{water}) = -\Delta T(\text{steam})$$

and

$$\Delta s(\text{water}) = -\Delta s(\text{steam})$$

Then the slopes of lines 1-2' and 4'-3 (Fig. 12.17) will be identical at every temperature and the lines will be identical in contour. Areas 4-4'-b-a-4 and 2'-1-d-c-2' are not only equal but congruous. Therefore, all the heat added from an external source (Q_1) is at the constant temperature T_1 , and all the heat rejected (Q_2) is at the constant temperature T_2 , both being reversible.

Then

$$Q_1 = h_1 - h_{4'} = T_1(s_1 - s_{4'})$$

$$Q_2 = h_{2'} - h_3 = T_2(s_{2'} - s_3)$$

Since

$$s_{4'} - s_3 = s_1 - s_{2'}$$

$$\text{or } s_1 - s_{4'} = s_{2'} - s_3$$

$$\therefore \eta = 1 - \frac{Q_2}{Q_1} = 1 - \frac{T_2}{T_1}$$

The efficiency of the ideal regenerative cycle is thus equal to the Carnot cycle efficiency.

Writing the steady flow energy equation for the turbine

$$h_1 - W_T - h_{2'} + h_4 - h_{4'} = 0$$

$$\text{or } W_T = (h_1 - h_{2'}) - (h_{4'} - h_4) \quad (12.17)$$

The pump work remains the same as in the Rankine cycle, i.e.

$$W_P = h_4 - h_3$$

The net work output of the ideal regenerative cycle is thus less, and hence its steam rate will be more, although it is more efficient, when compared with the Rankine cycle. However, the cycle is not practicable for the following reasons:

- Reversible heat transfer cannot be obtained in finite time.
- Heat exchanger in the turbine is mechanically impracticable.
- The moisture content of the steam in the turbine will be high.

12.8 Regenerative Cycle

In the practical regenerative cycle, the feedwater enters the boiler at a temperature between 4 and 4' (Fig. 12.17), and it is heated by steam extracted from intermediate stages of the turbine. The flow diagram of the regenerative cycle with saturated steam at the inlet to the turbine, and the corresponding T - s diagram are shown in Figs 12.18 and 12.19 respectively. For every kg of steam entering the turbine, let m_1 kg steam be extracted from an intermediate stage of the turbine where the pressure is p_2 , and it is used to heat up feedwater $[(1 - m_1)$ kg at state 8] by mixing in heater 1. The remaining $(1 - m_1)$ kg of steam then expands in the turbine from pressure p_2 (state 2) to pressure p_3 (state 3) when m_2 kg of steam is extracted for heating feedwater in heater 2. So $(1 - m_1 - m_2)$ kg of steam then expands in the remaining stages of the turbine to pressure p_4 , gets condensed into water in the condenser, and then pumped to heater 2, where it mixes with m_2 kg of steam extracted at pressure p_3 . Then $(1 - m_1)$ kg of water is pumped to heater 1 where it mixes with m_1 kg of steam extracted at pressure p_2 . The resulting 1 kg of steam is then pumped to the boiler where heat from an external source is supplied. Heaters 1 and 2 thus operate at pressures p_2 and p_3 respectively. The amounts of steam m_1 and m_2 extracted from the turbine are such that at the exit from each of the heaters, the state is saturated liquid at the respective pressures. The heat and work transfer quantities of the cycle are

$$W_T = 1(h_1 - h_2) + (1 - m_1)(h_2 - h_3) + (1 - m_1 - m_2)(h_3 - h_4) \text{ kJ/kg} \quad (12.18)$$

$$W_P = W_{P1} + W_{P2} + W_{P3}$$

$$= (1 - m_1 - m_2)(h_6 - h_5) + (1 - m_1)(h_8 - h_7) + 1(h_{10} - h_9) \text{ kJ/kg} \quad (12.19)$$

$$Q_1 = 1 (h_1 - h_{10}) \text{ kJ/kg} \quad (12.20)$$

$$Q_2 = (1 - m_1 - m_2) (h_4 - h_5) \text{ kJ/kg} \quad (12.21)$$

Cycle efficiency,
$$\eta = \frac{Q_1 - Q_2}{Q_1} = \frac{W_T - W_P}{Q_1}$$

$$\text{Steam rate} = \frac{3600}{W_T - W_P} \text{ kg/kW h}$$

In the Rankine cycle operating at the given pressures, p_1 and p_4 , the heat addition would have been from state 6 to state 1. By using two stages of regenerative feedwater heating, feedwater enters the boiler at state 10, instead of state 6, and heat addition is, therefore, from state 10 to state 1. Therefore

$$(T_{m_1})_{\text{with regeneration}} = \frac{h_1 - h_{10}}{s_1 - s_{10}} \quad (12.22)$$

and
$$(T_{m_1})_{\text{without regeneration}} = \frac{h_1 - h_6}{s_1 - s_6} \quad (12.23)$$

Since $(T_{m_1})_{\text{with regeneration}} > (T_{m_1})_{\text{without regeneration}}$ the efficiency of the regenerative cycle will be higher than that of the Rankine cycle.

The energy balance for heater 2 gives

$$m_1 h_2 + (1 - m_1) h_8 = 1 h_9$$

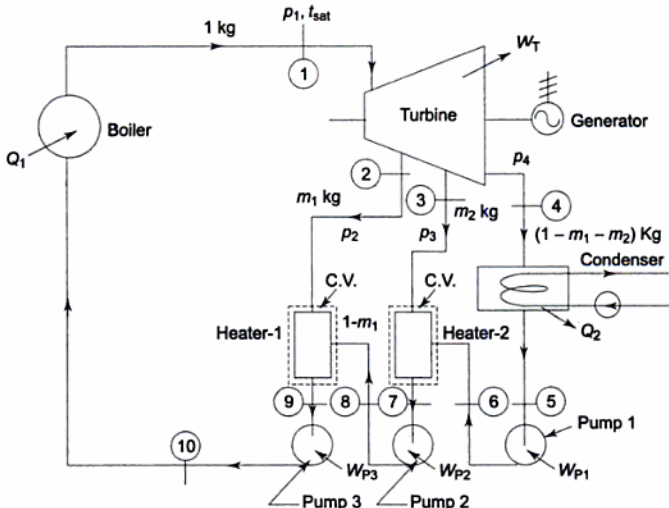

Fig. 12.18 Regenerative cycle flow diagram with two feedwater heaters

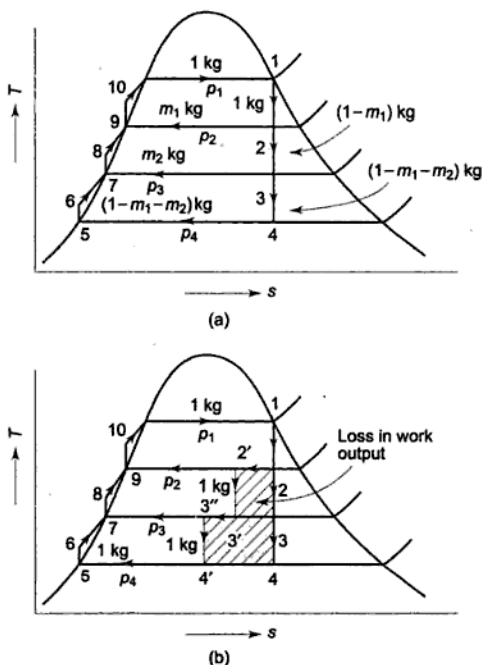

Fig. 12.19 (a) Regenerative cycle on T-s plot with decreasing mass of fluid
(b) Regenerative cycle on T-s plot for unit mass of fluid

$$\therefore m_1 = \frac{h_9 - h_8}{h_2 - h_8} \quad (12.24)$$

The energy balance for heater 1 gives

$$m_2 h_3 + (1 - m_1 - m_2) h_6 = (1 - m_1) h_7$$

$$\text{or } m_2 = (1 - m_1) \frac{h_7 - h_6}{h_3 - h_6} \quad (12.25)$$

From Eqs (12.24) and (12.25), m_1 and m_2 can be evaluated. Equations (12.24) and (12.25) can also be written alternatively as

$$(1 - m_1) (h_9 - h_8) = m_1 (h_2 - h_9)$$

$$(1 - m_1 - m_2) (h_7 - h_6) = m_2 (h_3 - h_7)$$

Energy gain of feedwater = Energy given off by vapour in condensation
Heaters have been assumed to be adequately insulated, and there is no heat gain from, or heat loss to, the surroundings.

Path 1-2-3-4 in Fig. 12.19 represents the states of a decreasing mass of fluid. For 1 kg of steam, the states would be represented by the path 1-2'-3'-4'. From equation (12.18),

$$W_T = (h_1 - h_2) + (1 - m_1)(h_2 - h_3) + (1 - m_1 - m_2)(h_3 - h_4) \\ = (h_1 - h_2) + (h_2 - h_3) + (h_3 - h_4) \quad (12.26)$$

where $(1 - m_1)(h_2 - h_3) = 1(h_2' - h_3') \quad (12.27)$

$$(1 - m_1 - m_2)(h_3 - h_4) = 1(h_3'' - h_4') \quad (12.28)$$

The cycle 1-2-2'-3'-3''-4'-5-6-7-8-9-10-1 represents 1 kg of working fluid. The heat released by steam condensing from 2 to 2' utilized in heating up the water from 8 to 9.

$$\therefore 1(h_2 - h_2') = 1(h_9 - h_8) \quad (12.29)$$

Similarly

$$1(h_3' - h_3'') = 1(h_7 - h_6) \quad (12.30)$$

From equations (12.26), (12.29) and (12.30)

$$W_T = (h_1 - h_4') - (h_2 - h_2') - h_3' - h_3'' \\ = (h_1 - h_4') - (h_9 - h_8) - (h_7 - h_6) \quad (12.31)$$

The similarity of equations (12.17) and (12.31) can be noticed. It is seen that the stepped cycle 1-2'-3'-4'-5-6-7-8-9-10 approximates the ideal regenerative cycle in Fig. 12.17, and that a greater number of stages would give a closer approximation (Fig. 12.20). Thus the heating of feedwater by steam 'bled' from the turbine, known as regeneration, *carnotizes* the Rankine cycle.

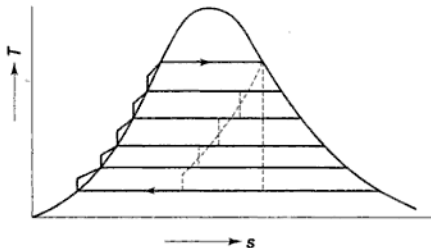

Fig. 12.20 Regenerative cycle with many stages of feedwater heating

The heat rejected Q_2 in the cycle decreases from $(h_4 - h_5)$ to $(h_4' - h_5)$. There is also loss in work output by the amount (Area under 2-2' + Area under 3'-3'' - Area under 4-4'), as shown by the hatched area in Fig. 12.19(b). So the steam rate increases by regeneration, i.e., more steam has to circulate per hour to produce unit shaft output.

The enthalpy-entropy diagram of a regenerative cycle is shown in Fig. 12.21.

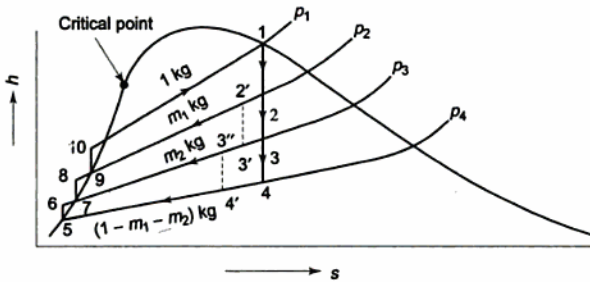

Fig. 12.21 Regenerative cycle on h - s diagram

12.9 Reheat-Regenerative Cycle

The reheating of steam is adopted when the vaporization pressure is high. The effect of reheat alone on the thermal efficiency of the cycle is very small. Regeneration or the heating up of feedwater by steam extracted from the turbine has a marked effect on cycle efficiency. A modern steam power plant is equipped with both. Figures 12.22 and 12.23 give the flow and T - s diagrams of a steam plant with reheat and three stages of feedwater heating. Here

$$W_T = (h_1 - h_2) + (1 - m_1)(h_2 - h_3) + (1 - m_1)(h_4 - h_5) + (1 - m_1 - m_2)(h_5 - h_6) + (1 - m_1 - m_2 - m_3)(h_6 - h_7) \text{ kJ/kg}$$

$$W_P = (1 - m_1 - m_2 - m_3)(h_9 - h_8) + (1 - m_1 - m_2)(h_{11} - h_{10}) + (1 - m_1)(h_{13} - h_{12}) + 1(h_{15} - h_{14}) \text{ kJ/kg}$$

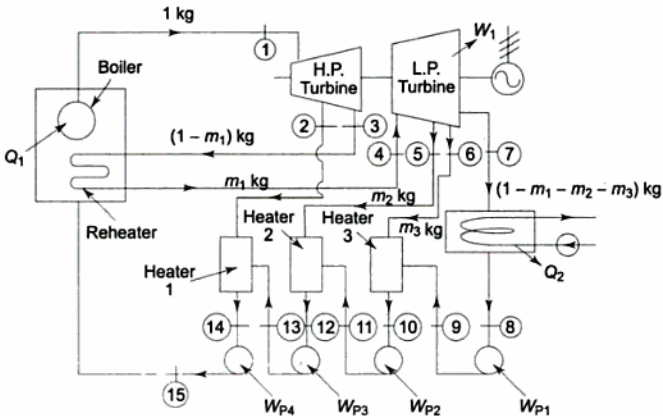

Fig. 12.22 Reheat-regenerative cycle flow diagram

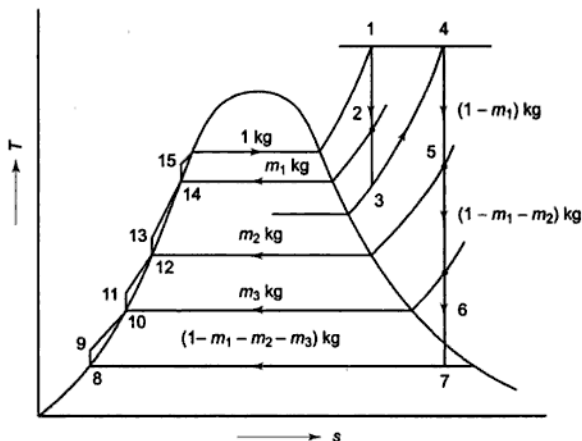

Fig. 12.23 *T-s diagram of reheat-regenerative cycle*

$$Q_1 = (h_1 - h_{15}) + (1 - m_1)(h_4 - h_3) \text{ kJ/kg}$$

and

$$Q_2 = (1 - m_1 - m_2 - m_3)(h_7 - h_8) \text{ kJ/kg}$$

The energy balances of heaters 1, 2, and 3 give

$$m_1 h_2 + (1 - m_1) h_{13} = 1 \times h_{14}$$

$$m_2 h_5 + (1 - m_1 - m_2) h_{11} = (1 - m_1) h_{12}$$

$$m_3 h_6 + (1 - m_1 - m_2 - m_3) h_9 = (1 - m_1 - m_2) h_{10}$$

from which m_1 , m_2 , and m_3 can be evaluated.

12.10 Feedwater Heaters

Feedwater heaters are of two types, viz., open heaters and closed heaters. In an open or contact-type heater, the extracted or bled steam is allowed to mix with feedwater, and both leave the heater at a common temperature, as shown in Figs 12.18 and 12.22. In a closed heater, the fluids are kept separate, and not allowed to mix together (Fig. 12.24). The feedwater flows through the tubes in the heater and the extracted steam condenses on the outside of the tubes in the shell. The heat released by condensation is transferred to the feedwater through the walls of the tubes. The condensate (saturated water at the steam extraction pressure), sometimes called the heater-drip, then passes through a trap into the next lower pressure heater. This, to some extent, reduces the steam required by that heater. The trap passes only liquid and no vapour. The drip from the lowest

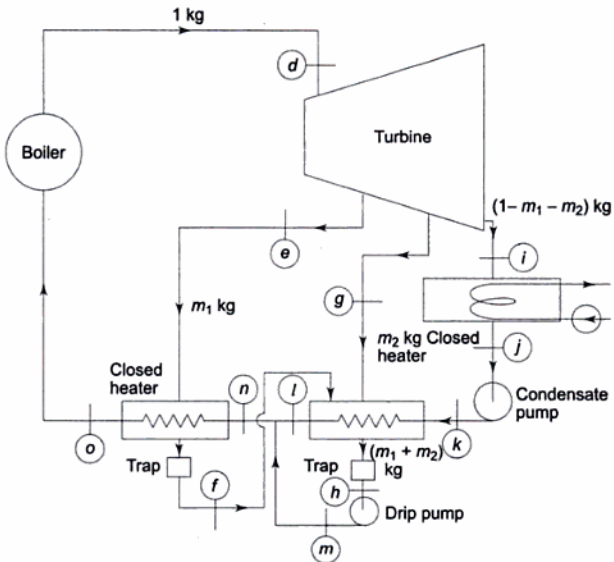

Fig. 12.24 Regenerative cycle flow diagram with closed feedwater heaters

pressure heater could similarly be trapped to the condenser, but this would be throwing away energy to the condenser cooling water. To avoid this waste, a drip pump feed the drip directly into the feedwater stream.

Figure 12.25 shows the T - s plot corresponding to the flow diagram in Fig. 12.24. The temperature of the feedwater (at 'l' or 'o') leaving a particular heater is always less than the saturation temperature at the steam extraction pressure (at e or g), the difference being known as the *terminal temperature difference* of the heater.

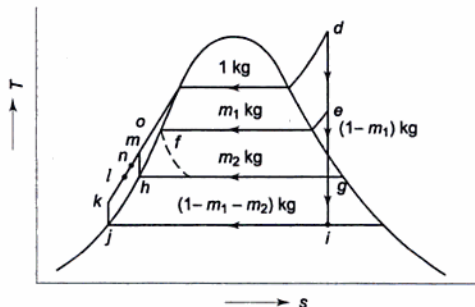

Fig. 12.25 T - s diagram of regenerative cycle with closed feedwater heaters

The advantages of the open heater are simplicity, lower cost, and high heat transfer capacity. The disadvantage is the necessity of a pump at each heater to handle the large feedwater stream.

A closed heater system requires only a single pump for the main feedwater stream regardless of the number of heaters. The drip pump, if used, is relatively small. Closed heaters are costly and may not give as high a feedwater temperature as do open heaters. In most steam power plants, closed heaters are favoured, but at least one open heater is used, primarily for the purpose of feedwater deaeration. The open heater in such a system is called the *deaerator*.

The higher the number of heaters used, the higher will be the cycle efficiency. If n heaters are used, the greatest gain in efficiency occurs when the overall temperature rise is about $n/(n+1)$ times the difference between the condenser and boiler saturation temperatures. (See *Analysis of Engineering Cycles* by R.W. Haywood, Pergamon Press, 1973).

If $(\Delta t)_0 = t_{\text{boiler sat}} - t_{\text{cond}}$ and $(\Delta t)_{\text{fw}}$ = temperature rise of feedwater it is seen that.

$$\begin{array}{lcl}
 n = 0, & (\Delta t)_{\text{fw}} = 0 & \\
 n = 1, & (\Delta t)_{\text{fw}} = \frac{1}{2} (\Delta t)_0 & \left. \begin{array}{l} \\ \\ \end{array} \right\} \text{Gain} = \frac{1}{6} (\Delta t)_0 \\
 n = 2, & (\Delta t)_{\text{fw}} = \frac{2}{3} (\Delta t)_0 & \left. \begin{array}{l} \\ \\ \end{array} \right\} \text{Gain} = \frac{1}{12} (\Delta t)_0 \\
 n = 3, & (\Delta t)_{\text{fw}} = \frac{3}{4} (\Delta t)_0 & \\
 n = 4, & (\Delta t)_{\text{fw}} = \frac{4}{5} (\Delta t)_0 & \left. \begin{array}{l} \\ \\ \end{array} \right\} \text{Gain} = \frac{1}{20} (\Delta t)_0
 \end{array}$$

Since the cycle efficiency is proportional to $(\Delta t)_{\text{fw}}$ the efficiency gain follows the law of diminishing return with the increase in the number of heaters. The greatest increment in efficiency occurs by the use of the first heater (Fig. 12.26). The increments for each additional heater thereafter successively diminish. The number of heaters is fixed up by the energy balance of the whole plant when it is found that the cost of adding another does not justify the saving in Q_1 or the marginal increase in cycle efficiency. An increase in feedwater temperature may, in some cases, cause a reduction in boiler efficiency. So the number of heaters gets optimized. Five points of extraction are often used in practice. Some cycles use as many as nine.

12.11 Exergy Analysis of Vapour Power Cycles

Let the heating for steam generation in the boiler unit is provided by a stream of hot gases produced by burning of a fuel (Fig. 12.27). The distribution of input energy is shown in the Sankey diagram 12.27 (b) which indicates that only about 30% of the input energy to the simple ideal plant is converted to shaft work and about 60% is lost to the condenser. The exergy analysis, however, gives a different distribution as discussed below.

Assuming that the hot gases are at atmospheric pressure, the exergy input is

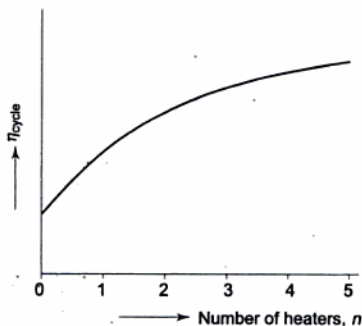

Fig. 12.26 Effect of the use of number of heaters on cycle efficiency

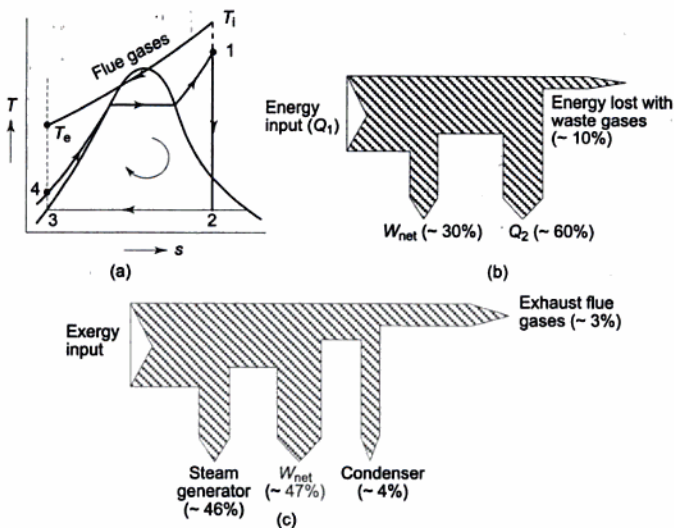

Fig. 12.27 (a) T - s diagram, (b) Sankey diagram, (c) Grassman diagram

$$\begin{aligned}
 a_{f_1} &= w_g c_{p_g} \left[T_i - T_0 - T_0 \ln \frac{T_i}{T_0} \right] \\
 &= w_g c_{p_g} T_0 \left[\frac{T_i}{T_0} - 1 - \ln \frac{T_i}{T_0} \right]
 \end{aligned}$$

Similarly, the exergy loss rate with the exhaust stream is:

$$a_{f_2} = w_g c_{p_g} T_0 \left[\frac{T_e}{T_0} - 1 - \ln \frac{T_e}{T_0} \right]$$

Net exergy input rate in the steam generation process:

$$a_{i1} = a_{f1} - a_{f2}$$

The exergy utilization rate in the steam generator is:

$$a_{f_u} = w_s [(h_1 - h_4)] - T_0(s_1 - s_4)$$

Rate of exergy loss in the steam generator:

$$I = a_{f1} - a_{f_u}$$

The useful mechanical power output:

$$= W_{\text{net}} = w_s [(h_1 - h_2) - (h_4 - h_3)]$$

Exergy flow rate of the wet steam to the condenser:

$$a_{f_c} = w_s [(h_2 - h_3) - T_0(s_2 - s_3)]$$

Second law efficiency,
$$\eta_{II} = \frac{W_{\text{net}}}{a_{f1} - a_{f2}}$$

Exergy flow or Grassmann diagram is shown in Fig. 12.27 (c). The energy disposition diagram (b) shows that the major energy loss (~60%) takes place in the condenser. This energy rejection, however, occurs at a temperature close to the ambient temperature, and, therefore, corresponds to a very low exergy value (~4%). The major exergy destruction due to irreversibilities takes place in the steam generation. To improve the performance of the steam plant the finite source temperatures must be closer to the working fluid temperatures to reduce thermal irreversibility.

12.12 Characteristics of an Ideal Working Fluid in Vapour Power Cycles

There are certain drawbacks with steam as the working substance in a power cycle. The maximum temperature that can be used in steam cycles consistent with the best available material is about 600°C, while the critical temperature of steam is 375°C, which necessitates large superheating and permits the addition of only an infinitesimal amount of heat at the highest temperature.

High moisture content is involved in going to higher steam pressures in order to obtain higher mean temperature of heat addition (T_{m1}). The use of reheat is thus necessitated. Since reheater tubes are costly, the use of more than two reheats is hardly recommended. Also, as pressure increases, the metal stresses increase, and the thicknesses of the walls of boiler drums, tubes, pipe lines, etc., increase not in proportion to pressure increase, but much faster, because of the prevalence of high temperature.

It may be noted that high T_{m1} is only desired for high cycle efficiency. High pressures are only forced by the characteristics (weak) of steam.

If the lower limit is now considered, it is seen that at the heat rejection temperature of 40°C, the saturation pressure of steam is 0.075 bar, which is considerably lower than atmospheric pressure. The temperature of heat rejection

can be still lowered by using some refrigerant as a coolant in the condenser. The corresponding vacuum will be still higher, and to maintain such low vacuum in the condenser is a big problem.

It is the low temperature of heat rejection that is of real interest. The necessity of a vacuum is a disagreeable characteristic of steam.

The saturated vapour line in the $T-s$ diagram of steam is sufficiently inclined, so that when steam is expanded to lower pressures (for higher turbine output as well as cycle efficiency), it involves more moisture content, which is not desired from the consideration of the erosion of turbine blades in later stages.

The desirable characteristics of the working fluid in a vapour power cycle to obtain best thermal efficiency are given below.

- The fluid should have a high critical temperature so that the saturation pressure at the maximum permissible temperature (metallurgical limit) is relatively low. It should have a large enthalpy of evaporation at that pressure.
- The saturation pressure at the temperature of heat rejection should be above atmospheric pressure so as to avoid the necessity of maintaining vacuum in the condenser.
- The specific heat of liquid should be small so that little heat transfer is required to raise the liquid to the boiling point.
- The saturated vapour line of the $T-s$ diagram should be steep, very close to the turbine expansion process so that excessive moisture does not appear during expansion.
- The freezing point of the fluid should be below room temperature, so that it does not get solidified while flowing through the pipelines.
- The fluid should be chemically stable and should not contaminate the materials of construction at any temperature.
- The fluid should be nontoxic, noncorrosive, not excessively viscous, and low in cost.

The characteristics of such an ideal fluid are approximated in the $T-s$ diagram as shown in Fig. 12.28. Some superheat is desired to reduce piping losses and

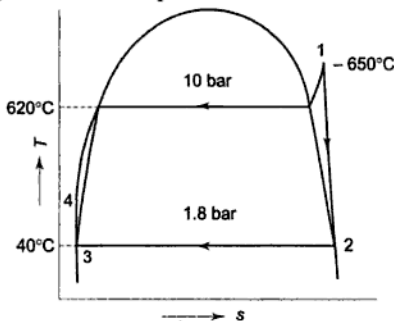

Fig. 12.28 $T-s$ diagram of an ideal working fluid for a vapour power cycle

improve turbine efficiency. The thermal efficiency of the cycle is very close to the Carnot efficiency.

12.13 Binary Vapour Cycles

No single fluid can meet all the requirements as mentioned above. Although in the overall evaluation, water is better than any other working fluid, however, in the high temperature range, there are a few better fluids, and notable among them are (a) diphenyl ether, $(C_6H_5)_2O$, (b) aluminium bromide, Al_2Br_6 , and (c) mercury and other liquid metals like sodium or potassium. From among these, only mercury has actually been used in practice. Diphenyl ether could be considered, but it has not yet been used because, like most organic substances, it decomposes gradually at high temperatures. Aluminium bromide is a possibility and yet to be considered.

When $p = 12$ bar, the saturation temperature for water, aluminium bromide, and mercury are $187^\circ C$, $482.5^\circ C$, and $560^\circ C$ respectively. Mercury is thus a better fluid in the higher temperature range, because at high temperature, its vaporization pressure is relatively low. Its critical pressure and temperature are 1080 bar and $1460^\circ C$ respectively.

But in the low temperature range, mercury is unsuitable, because its saturation pressure becomes exceedingly low and it would be impractical to maintain such a high vacuum in the condenser. At $30^\circ C$, the saturation pressure of mercury is only 2.7×10^{-4} cm Hg. Its specific volume at such a low pressure is very large, and it would be difficult to accommodate such a large volume flow.

For this reason, mercury vapour leaving the mercury turbine is condensed at a higher temperature, and the heat released during the condensation of mercury is utilized in evaporating water to form steam to operate on a conventional turbine.

Thus in the binary (or two-fluid) cycle, two cycles with different working fluids are coupled in series, the heat rejected by one being utilized in the other.

The flow diagram of mercury-steam binary cycle and the corresponding $T-s$ diagram are given in Figs 12.29 and 12.30 respectively. The mercury cycle, $a-b-c-d$, is a simple Rankine type of cycle using saturated vapour. Heat is supplied to the mercury in process $d-a$. The mercury expands in a turbine (process $a-b$) and is then condensed in process $b-c$. The feed pump process, $c-d$, completes the cycle.

The heat rejected by mercury during condensation is transferred to boil water and form saturated vapour (process 5-6). The saturated vapour is heated from the external source (furnace) in the superheater (process 6-1). Superheated steam expands in the turbine (process 1-2) and is then condensed (process 2-3). The feedwater (condensate) is then pumped (process 3-4), heated till it is saturated liquid in the economizer (process 4-5) before going to the mercury condenser-steam boiler, where the latent heat is absorbed. In an actual plant the steam cycle is always a regenerative cycle, but for the sake of simplicity, this complication has been omitted.

Let m represent the flow rate of the mercury in the mercury cycle per kg of steam circulating in the steam cycle. Then for 1 kg of steam

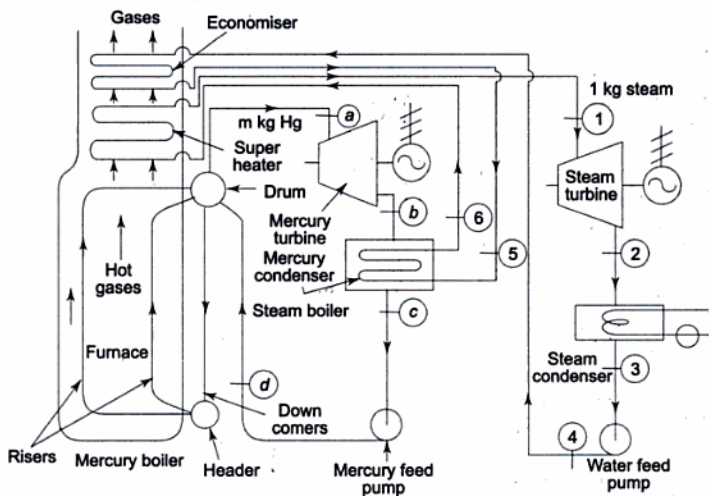

Fig. 12.29 Mercury-steam plant flow diagram

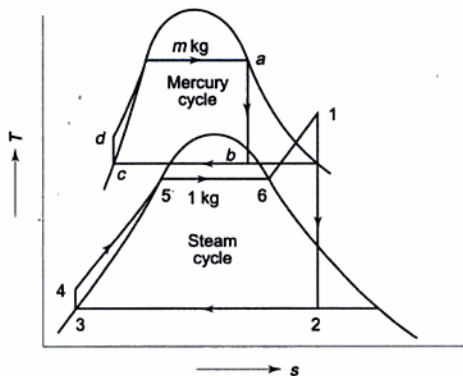

Fig. 12.30 Mercury-steam binary cycle

$$Q_1 = m(h_a - h_d) + (h_1 - h_6) + (h_5 - h_4)$$

$$Q_2 = h_2 - h_3$$

$$W_T = m(h_a - h_b) + (h_1 - h_2)$$

$$W_P = m(h_d - h_c) + (h_4 - h_3)$$

$$\eta_{\text{cycle}} = \frac{Q_1 - Q_2}{Q_1} = \frac{W_T - W_P}{Q_1}$$

$$\text{and steam rate} = \frac{3600}{W_T - W_P} \text{ kg/kWh}$$

The energy balance of the mercury condenser-steam boiler gives

$$m(h_b - h_c) = h_6 - h_5$$

$$\therefore m = \frac{h_6 - h_5}{h_b - h_c} \text{ kg Hg/kg H}_2\text{O}$$

To vaporize one kg of water, seven to eight kg of mercury must condense.

The addition of the mercury cycle to the steam cycle results in a marked increase in the mean temperature of heat addition to the plant as a whole and consequently the efficiency is increased. The maximum pressure is relatively low.

It may be interesting to note that the concept of the binary vapour cycle evolved from the need of improving the efficiency of the reciprocating steam engine. When steam expands up to, say, atmospheric temperature, the resultant volume flow rate of steam becomes too large for the steam engine cylinder to accommodate. So most of the early steam engines are found to be non-condensing. The binary cycle with steam in the high temperature and ammonia or sulphur dioxide in the low temperature range, was first suggested by Professor Josse of Germany in the middle of the nineteenth century. Steam exhausted from the engine at a relatively higher pressure and temperature was used to evaporate ammonia or sulphur dioxide which operated on another cycle. But with the progress in steam turbine design, such a cycle was found to be of not much utility, since modern turbines can cope efficiently with a large volume flow of steam.

The mercury-steam cycle has been in actual commercial use for more than three decades. One such plant is the Schiller Station in the USA. But it has never attained wide acceptance because there has always been the possibility of improving steam cycles by increasing pressure and temperature, and by using reheat and regeneration. Over the above, mercury is expensive, limited in supply, and highly toxic.

The mercury-steam cycle represents the two-fluid cycles. The mercury cycle is called the *topping cycle* and the steam cycle is called the *bottoming cycle*. If a sulphur dioxide cycle is added to it in the low temperature range, so that the heat released during the condensation of steam is utilized in forming sulphur dioxide vapour which expands in another turbine, then the mercury-steam-sulphur dioxide cycle is a three-fluid or tertiary cycle. Similarly, other liquid metals, apart from mercury, like sodium or potassium, may be considered for a working fluid in the topping cycle. Apart from SO_2 other refrigerants (ammonia, freons, etc.) may be considered as working fluids for the bottoming cycle.

Since the possibilities of improving steam cycles are diminishing, and the incentives to reduce fuel cost are very much increasing, coupled cycles, like the mercury-steam cycle, may receive more favourable consideration in the near future.

12.14 Thermodynamics of Coupled Cycles

If two cycles are coupled in series where heat lost by one is absorbed by the other (Fig. 12.31), as in the mercury-steam binary cycle, let η_1 and η_2 be the efficiencies of the topping and bottom cycles respectively, and η be the overall efficiency of the combined cycle.

$$\eta_1 = 1 - \frac{Q_2}{Q_1} \quad \text{and} \quad \eta_2 = 1 - \frac{Q_3}{Q_2}$$

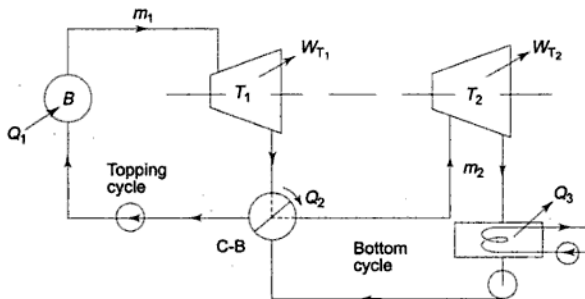

Fig. 12.31 Two vapour cycles coupled in series

or
$$Q_2 = Q_1(1 - \eta_1) \quad \text{and} \quad Q_3 = Q_2(1 - \eta_2)$$

Now
$$\eta = 1 - \frac{Q_3}{Q_1} = 1 - \frac{Q_2(1 - \eta_2)}{Q_1}$$

$$= 1 - \frac{Q_1(1 - \eta_1)(1 - \eta_2)}{Q_1}$$

$$= 1 - (1 - \eta_1)(1 - \eta_2)$$

If there are n cycles coupled in series, the overall efficiency would be given by

$$\eta = 1 - \prod_{i=1}^n (1 - \eta_i)$$

i.e.
$$\eta = 1 - (1 - \eta_1)(1 - \eta_2)(1 - \eta_3) \dots (1 - \eta_n)$$

or
$$1 - \eta = (1 - \eta_1)(1 - \eta_2)(1 - \eta_3) \dots (1 - \eta_n).$$

\therefore Total loss = Product of losses in all the cycles.

For two cycles coupled in series

$$\eta = 1 - (1 - \eta_1)(1 - \eta_2)$$

$$= 1 - (1 - \eta_1 - \eta_2 + \eta_1\eta_2)$$

$$= \eta_1 + \eta_2 - \eta_1\eta_2$$

or
$$\eta = \eta_1 + \eta_2 - \eta_1\eta_2$$

This shows that the overall efficiency of two cycles coupled in series equals the sum of the individual efficiencies minus their product.

By combining two cycles in series, even if individual efficiencies are low, it is possible to have a fairly high combined efficiency, which cannot be attained by a single cycle.

For example, if $\eta_1 = 0.50$ and $\eta_2 = 0.40$
 $\eta = 0.5 + 0.4 - 0.5 \times 0.4 = 0.70$

It is almost impossible to achieve such a high efficiency in a single cycle.

12.15 Process Heat and By-Product Power

There are several industries, such as paper mills, textile mills, chemical factories, dyeing plants, rubber manufacturing plants, sugar factories, etc., where saturated steam at the desired temperature is required for heating, drying, etc. For constant temperature heating (or drying), steam is a very good medium, since isothermal condition can be maintained by allowing saturated steam to condense at that temperature and utilizing the latent heat released for heating purposes. Apart from the process heat, the factory also needs power to drive various machines, for lighting, and for other purposes.

Formerly it was the practice to generate steam for power purposes at a moderate pressure and to generate separately saturated steam for process work at a pressure which gave the desired heating temperature. Having two separate units for process heat and power is wasteful, for of the total heat supplied to the steam for power purposes, a greater part will normally be carried away by the cooling water in the condenser.

By modifying the initial steam pressure and exhaust pressure, it is possible to generate the required power and make available for process work the required quantity of exhaust steam at the desired temperature. In Fig. 12.32, the exhaust steam from the turbine is utilized for process heating, the process heater replacing the condenser of the ordinary Rankine cycle. The pressure at exhaust from the

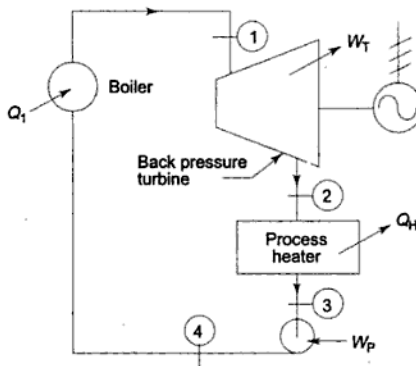

Fig. 12.32 Back pressure turbine

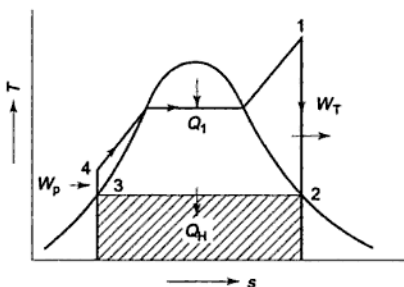

Fig. 12.33 By-product power cycle

turbine is the saturation pressure corresponding to the temperature desired in the process heater. Such a turbine is called a *back pressure turbine*. A plant producing both power and process heat is sometimes known as a *cogeneration plant*. When the process steam is the basic need, and the power is produced incidentally as a by-product, the cycle is sometimes called a *by-product power cycle*. Figure 12.33 shows the T - s plot of such a cycle. If W_T is the turbine output in kW, Q_H the process heat required in kJ/h, and w is the steam flow rate in kg/h

$$W_T \times 3600 = w(h_1 - h_2)$$

and $w(h_2 - h_3) = Q_H$

$$\therefore W_T \times 3600 = \frac{Q_H}{h_2 - h_3} (h_1 - h_2)$$

or $Q_H = \frac{W_T \times 3600 \times (h_2 - h_3)}{h_1 - h_2}$ kJ/h

Of the total energy input Q_1 (as heat) to the by-product cycle, W_T part of it only is converted into shaft work (or electricity). The remaining energy ($Q_1 - W_T$), which would otherwise have been a waste, as in the Rankine cycle (by the Second Law), is utilized as process heat.

Fraction of energy (Q_1) utilized in the form of work (W_T), and process heat (Q_H) in a by-product power cycle

$$= \frac{W_T + Q_H}{Q_1}$$

Condenser loss, which is the biggest loss in a steam plant, is here zero, and the fraction of energy utilized is very high.

In many cases the power available from the back pressure turbine through which the whole of the heating steam flows is appreciably less than that required in the factory. This may be due to relatively high back pressure, or small heating requirement, or both. *Pass-out turbines* are employed in these cases, where a certain quantity of steam is continuously extracted for heating purposes at the desired temperature and pressure. (Figs 12.34 and 12.35).

$$Q_1 = w(h_1 - h_8) \text{ kJ/h}$$

$$Q_2 = (w - w_1)(h_3 - h_4) \text{ kJ/h}$$

$$Q_H = w_1(h_2 - h_6) \text{ kJ/h}$$

$$W_T = w(h_1 - h_2) + (w - w_1)(h_2 - h_3) \text{ kJ/h}$$

$$W_P = (w - w_1)(h_5 - h_4) + w_1(h_7 - h_6) \text{ kJ/h}$$

$$w_1 h_7 + (w - w_1)h_5 = w \times h_8$$

where w is the boiler capacity (kg/h) and w_1 is the steam flow rate required (kg/h) at the desired temperature for process heating.

12.16 Efficiencies in Steam Power Plant

For the steady flow operation of a turbine, neglecting changes in K.E. and P.E. (Figs 12.36 and 12.37).

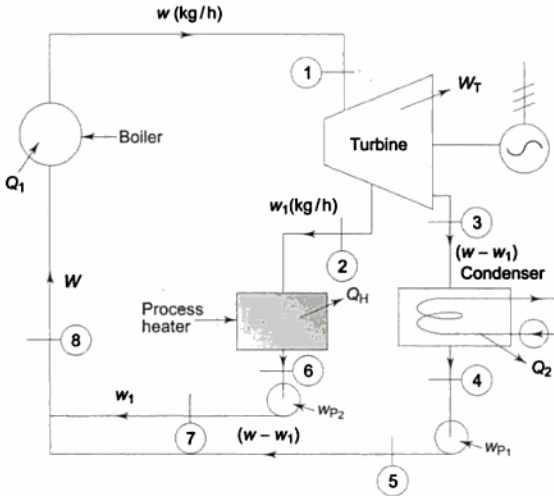

Fig. 12.34 Pass-out turbine

Maximum or ideal work output per unit mass of steam

$$(W_T)_{\max} = (W_T)_{\text{ideal}} = h_1 - h_{2s}$$

= Reversible and adiabatic enthalpy drop in turbine

This work is, however, not obtainable, since no real process is reversible. The expansion process is accompanied by irreversibilities. The actual final state 2 can be defined, since the temperature, pressure, and quality can be found by actual measurement. The actual path 1–2 is not known and its nature is immaterial, since the work output is here being expressed in terms of the change of a property,

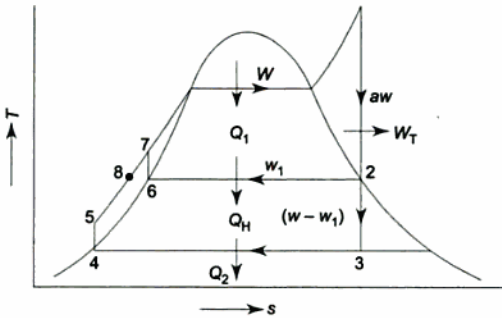

Fig. 12.35 $T-s$ diagram of power and process heat plant

enthalpy. Accordingly, the work done by the turbine in irreversible adiabatic expansion from 1 to 2 is

$$(W_T)_{\text{actual}} = h_1 - h_2$$

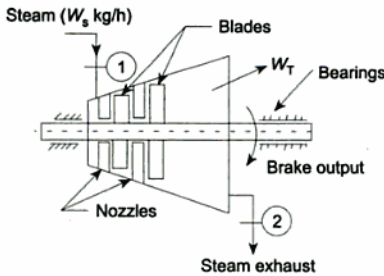

Fig. 12.36 Efficiencies in a steam turbine

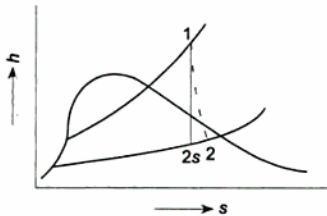

Fig. 12.37 Internal efficiency of a steam turbine

This work is known as *internal work*, since only the irreversibilities within the flow passages of turbine are affecting the state of steam at the turbine exhaust.

∴ Internal output = Ideal output – Friction and other losses within the turbine casing

If w_s is the steam flow rate in kg/h

$$\text{Internal output} = w_s(h_1 - h_2) \text{ kJ/h}$$

$$\text{Ideal output} = w_s(h_1 - h_{2s}) \text{ kJ/h}$$

The *internal efficiency* of turbine is defined as

$$\eta_{\text{internal}} = \frac{\text{Internal output}}{\text{Ideal output}} = \frac{h_1 - h_2}{h_1 - h_{2s}}$$

Work output available at the shaft is less than the internal output because of the external losses in the bearings, etc.

∴ Brake output or shaft output

$$= \text{Internal output} - \text{External losses}$$

$$= \text{Ideal output} - \text{Internal and External losses}$$

$$= (\text{kW} \times 3600 \text{ kJ/h})$$

The *brake efficiency* of turbine is defined as

$$\begin{aligned} \eta_{\text{brake}} &= \frac{\text{Brake output}}{\text{Ideal output}} \\ &= \frac{\text{kW} \times 3600}{w_s(h_1 - h_{2s})} \end{aligned}$$

The *mechanical efficiency* of turbine is defined as

$$\begin{aligned} \eta_{\text{mech}} &= \frac{\text{Brake output}}{\text{Internal output}} \\ &= \frac{\text{kW} \times 3600}{w_s(h_1 - h_2)} \end{aligned}$$

$$\therefore \eta_{\text{brake}} = \eta_{\text{internal}} \times \eta_{\text{mech}}$$

While the internal efficiency takes into consideration the internal losses, and the mechanical efficiency considers only the external losses, the brake efficiency takes into account both the internal and external losses (with respect to turbine casing).

The generator (or *alternator*) efficiency is defined as

$$\eta_{\text{generator}} = \frac{\text{Output at generator terminals}}{\text{Brake output of turbine}}$$

The *efficiency of the boiler* is defined as

$$\eta_{\text{boiler}} = \frac{\text{Energy utilized}}{\text{Energy supplied}} = \frac{w_s(h_1 - h_4)}{w_f \times \text{C.V.}}$$

where w_f is the fuel burning rate in the boiler (kg/h) and C.V. is the calorific value of the fuel (kJ/kg), i.e., the heat energy released by the complete combustion of unit mass of fuel.

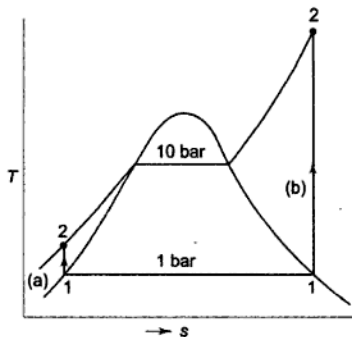

Fig. Ex. 12.1 Compression of steam isentropically

$$T ds = dh - v dp = 0$$

or

$$v dp = dh$$

$$W_{\text{rev}} = - \int_1^2 v dp = - \int_1^2 dh = h_1 - h_2$$

From steam tables,

$$h_1 = (h_g)_{1\text{bar}} = 2675.5 \text{ kJ/kg}$$

$$s_1 = (s_g)_{1\text{bar}} = 7.3594 \text{ kJ/kg K} = s_2$$

For $p = 10 \text{ bar} = 1 \text{ MPa}$ and $s = 7.3594 \text{ kJ/kg K}$, by interpolation

$$h_2 = 3195.5 \text{ kJ/kg}$$

$$W_{\text{rev}} = 2675.5 - 3195.5 = -520 \text{ kJ/kg}$$

It is thus observed that compressing steam in vapour form would require over 500 times more work than compressing it in liquid form for the same pressure rise.

Example 12.2 Steam at 20 bar, 360°C is expanded in a steam turbine to 0.08 bar. It then enters a condenser, where it is condensed to saturated liquid water. The pump feeds back the water into the boiler. (a) Assuming ideal processes, find per kg of steam the net work and the cycle efficiency. (b) If the turbine and the pump have each 80% efficiency, find the percentage reduction in the net work and cycle efficiency.

Solution The property values at different state points (Fig. Ex. 12.2) found from the steam tables are given below.

$$h_1 = 3159.3 \text{ kJ/kg} \quad s_1 = 6.9917 \text{ kJ/kg K}$$

$$h_3 = h_{\text{fp}2} = 173.88 \text{ kJ/kg} \quad s_3 = s_{\text{fp}2} = 0.5926 \text{ kJ/kg K}$$

$$h_{\text{fgp}2} = 2403.1 \text{ kJ/kg} \quad s_{\text{fgp}2} = 8.2287 \text{ kJ/kg K}$$

$$v_{\text{fp}2} = 0.001008 \text{ m}^3/\text{kg} \quad \therefore s_{\text{fgp}2} = 7.6361 \text{ kJ/kg K}$$

Now

$$s_1 = s_{2s} = 6.9917 = s_{\text{fp}2} + x_{2s} s_{\text{fgp}2} = 0.5926 + x_{2s} \cdot 7.6361$$

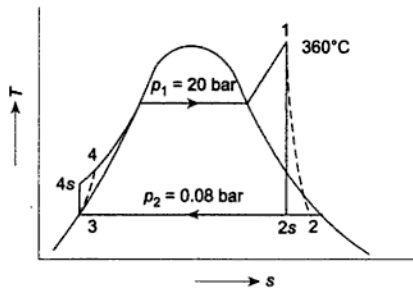

Fig. Ex. 12.2

$$\therefore x_{2s} = \frac{6.3991}{7.6361} = 0.838$$

$$\therefore h_{2s} = h_{fp2} + x_{2s} h_{fgp2} = 173.88 + 0.838 \times 2403.1 = 2187.68 \text{ kJ/kg}$$

$$(a) \quad W_p = h_{4s} - h_3 = v_{fp2} (p_1 - p_2) = 0.001008 \frac{\text{m}^3}{\text{kg}} \times 19.92 \times 100 \frac{\text{kN}}{\text{m}^2} = 2.008 \text{ kJ/kg}$$

$$h_{4s} = 175.89 \text{ kJ/kg}$$

$$W_T = h_1 - h_{2s} = 3159.3 - 2187.68 = 971.62 \text{ kJ/kg}$$

$$\therefore W_{\text{net}} = W_T - W_p = 969.61 \text{ kJ/kg}$$

$$Q_1 = h_1 - h_{4s} = 3159.3 - 175.89$$

$$= 2983.41 \text{ kJ/kg} \quad \text{Ans.}$$

$$\therefore \eta_{\text{cycle}} = \frac{W_{\text{net}}}{Q_1} = \frac{969.61}{2983.41} = 0.325, \text{ or } 32.5\%$$

$$(b) \text{ If } \eta_p = 80\%, \text{ and } \eta_T = 80\% \quad \text{Ans.}$$

$$W_p = \frac{2.008}{0.8} = 2.51 \text{ kJ/kg}$$

$$W_T = 0.8 \times 971.62 = 777.3 \text{ kJ/kg}$$

$$\therefore W_{\text{net}} = W_T - W_p = 774.8 \text{ kJ/kg}$$

\(\therefore\) % Reduction in work output

$$= \frac{969.61 - 774.8}{969.61} \times 100 = 20.1\% \quad \text{Ans.}$$

$$h_{4s} = 173.88 + 2.51 = 176.39 \text{ kJ/kg}$$

$$\therefore Q_1 = 3159.3 - 176.39 = 2982.91 \text{ kJ/kg}$$

$$\therefore \eta_{\text{cycle}} = \frac{774.8}{2982.91} = 0.2597, \text{ or } 25.97\%$$

∴ % Reduction in cycle efficiency

$$= \frac{0.325 - 0.2597}{0.325} \times 100 = 20.1\%$$

Ans.

Example 12.3 A cyclic steam power plant is to be designed for a steam temperature at turbine inlet of 360°C and an exhaust pressure of 0.08 bar. After isentropic expansion of steam in the turbine, the moisture content at the turbine exhaust is not to exceed 15%. Determine the greatest allowable steam pressure at the turbine inlet, and calculate the Rankine cycle efficiency for these steam conditions. Estimate also the mean temperature of heat addition.

Solution As state 2s (Fig. Ex. 12.3), the quality and pressure are known.

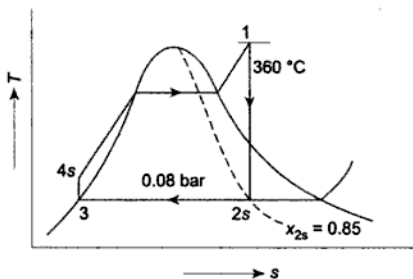

Fig. Ex. 12.3

$$\therefore s_{2s} = s_f + x_{2s} s_{fg} = 0.5926 + 0.85 (8.2287 - 0.5926) = 7.0833 \text{ kJ/kg K}$$

Since

$$s_1 = s_{2s}$$

∴

$$s_1 = 7.0833 \text{ kJ/kg K}$$

At state 1, the temperature and entropy are thus known. At 360°C, $s_g = 5.0526$ kJ/kg K, which is less than s_1 . So from the table of superheated steam, at $t_1 = 360^\circ\text{C}$ and $s_1 = 7.0833$ kJ/kg K, the pressure is found to be 16.832 bar (by interpolation).

∴ The greatest allowable steam pressure is

$$p_1 = 16.832 \text{ bar}$$

Ans.

$$h_1 = 3165.54 \text{ kJ/kg}$$

$$h_{2s} = 173.88 + 0.85 \times 2403.1 = 2216.52 \text{ kJ/kg}$$

$$h_3 = 173.88 \text{ kJ/kg}$$

$$h_{4s} - h_3 = 0.001 \times (16.83 - 0.08) \times 100 = 1.675 \text{ kJ/kg}$$

∴

$$h_{4s} = 175.56 \text{ kJ/kg}$$

$$Q_1 = h_1 - h_{4s} = 3165.54 - 175.56$$

$$= 2990 \text{ kJ/kg}$$

$$W_T = h_1 - h_{2s} = 3165.54 - 2216.52 = 949 \text{ kJ/kg}$$

$$W_P = 1.675 \text{ kJ/kg}$$

$$\eta_{\text{cycle}} = \frac{W_{\text{net}}}{Q_1} = \frac{247.32}{2990} = 0.3168 \text{ or } 31.68\% \quad \text{Ans.}$$

Mean temperature of heat addition

$$T_{\text{ml}} = \frac{h_1 - h_{4s}}{s_1 - s_{4s}} = \frac{2990}{7.0833 - 0.5926} \\ = 460.66 \text{ K} = 187.51^\circ\text{C}.$$

Example 12.4 A steam power station uses the following cycle:

Steam at boiler outlet—150 bar, 550°C

Reheat at 40 bar to 550°C

Condenser at 0.1 bar.

Using the Mollier chart and assuming ideal processes, find the (a) quality at turbine exhaust, (b) cycle efficiency, and (c) steam rate.

Solution The property values at different states (Fig. Ex. 12.4) are read from the Mollier chart.

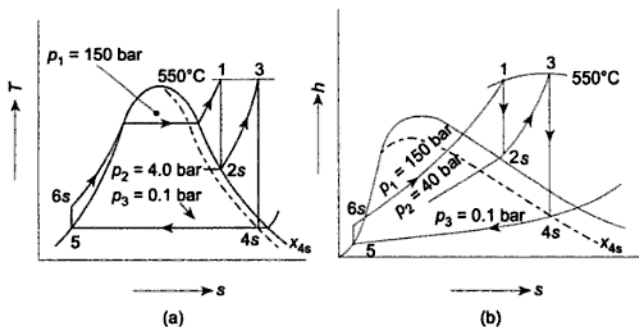

Fig. Ex. 12.4

$$h_1 = 3465, h_{2s} = 3065, h_3 = 3565,$$

$$h_{4s} = 2300 \text{ kJ/kg } x_{4s} = 0.88, h_5(\text{steam table}) = 191.83 \text{ kJ/kg}$$

Quality at turbine exhaust = 0.88

Ans. (a)

$$W_P = v \Delta p = 10^{-3} \times 150 \times 10^2 = 15 \text{ kJ/kg}$$

$$h_{6s} = 206.83 \text{ kJ/kg}$$

$$Q_1 = (h_1 - h_{6s}) + (h_3 - h_{2s})$$

$$= (3465 - 206.83) + (3565 - 3065) = 3758.17 \text{ kJ/kg}$$

$$W_T = (h_1 - h_{2s}) + (h_3 - h_{4s})$$

$$= (3465 - 3065) + (3565 - 2300) = 1665 \text{ kJ/kg}$$

$$\therefore W_{\text{net}} = W_T - W_P = 1665 - 15 = 1650 \text{ kJ/kg}$$

$$\therefore \eta_{\text{cycle}} = \frac{W_{\text{net}}}{Q_1} = \frac{1650}{3758.17} = 0.4390, \text{ or } 43.9\% \quad \text{Ans. (b)}$$

$$\text{Steam rate} = \frac{3600}{1650} = 2.18 \text{ kg/kWh} \quad \text{Ans. (c)}$$

Example 12.5 In a single-heater regenerative cycle the steam enters the turbine at 30 bar, 400°C and the exhaust pressure is 0.10 bar. The feedwater heater is a direct-contact type which operates at 5 bar. Find (a) the efficiency and the steam rate of the cycle and (b) the increase in mean temperature of heat addition, efficiency and steam rate, as compared to the Rankine cycle (without regeneration). Neglect pump work.

Solution Figure Ex. 12.5 gives the flow, T - s , and h - s diagrams. From the steam tables, the property values at various states have been obtained.

$$h_1 = 3230.9 \text{ kJ/kg}$$

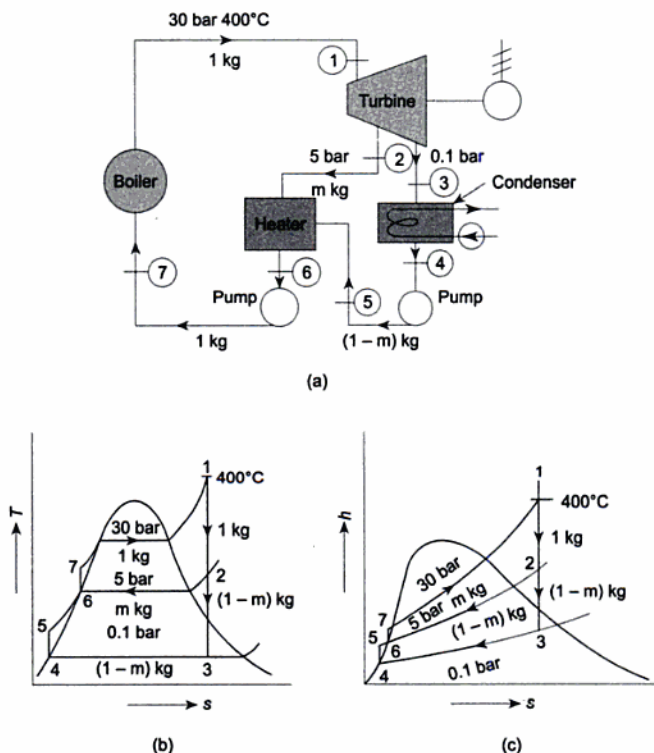

Fig. Ex. 12.5

$$s_1 = 6.9212 \text{ kJ/kg K} = s_2 = s_3$$

$$s_g \text{ at 5 bar} = 6.8213 \text{ kJ/kg K}$$

Since $s_2 > s_g$, the state 2 must lie in the superheated region. From the table for superheated steam $t_2 = 172^\circ\text{C}$, $h_2 = 2796 \text{ kJ/kg}$

$$\begin{aligned} s_3 &= 6.9212 = s_{f0.1\text{bar}} + x_{3s} s_{fg0.1\text{bar}} \\ &= 0.6493 + x_3 7.5009 \end{aligned}$$

$$\therefore x_3 = \frac{6.2719}{7.5009} = 0.836$$

$$\therefore h_3 = 191.83 + 0.836 \times 2392.8 = 2192.2 \text{ kJ/kg}$$

Since pump work is neglected

$$h_4 = 191.83 \text{ kJ/kg} = h_5$$

$$h_6 = 640.23 \text{ kJ/kg} = h_7$$

Energy balance for the heater gives

$$m(h_2 - h_6) = (1 - m)(h_6 - h_5)$$

$$m(2796 - 640.23) = (1 - m)(640.23 - 191.83)$$

$$2155.77 m = 548.4 - 548.4 m$$

$$\therefore m = \frac{548.4}{2704.17} = 0.203 \text{ kg}$$

$$\begin{aligned} \therefore W_T &= (h_1 - h_2) + (1 - m)(h_2 - h_3) \\ &= (3230.9 - 2796) + 0.797(2796 - 2192.2) \\ &= 916.13 \text{ kJ/kg} \end{aligned}$$

$$Q_1 = h_1 - h_6 = 3230.9 - 640.23 = 2590.67 \text{ kJ/kg}$$

$$\eta_{\text{cycle}} = \frac{916.13}{2590.67} = 0.3536, \text{ or } 35.36\% \quad \text{Ans. (a)}$$

$$\text{Steam rate} = \frac{3600}{916.13} = 3.93 \text{ kg/kW h} \quad \text{Ans. (a)}$$

$$\begin{aligned} T_{m1} &= \frac{h_1 - h_7}{s_1 - s_7} = \frac{2590.67}{6.9212 - 1.8607} = 511.95 \text{ K} \\ &= 238.8^\circ\text{C} \end{aligned}$$

$$\begin{aligned} T_{m1} \text{ (without regeneration)} &= \frac{h_1 - h_4}{s_1 - s_4} \\ &= \frac{3039.07}{6.9212 - 0.6493} \\ &= 484.55 \text{ K} \\ &= 211.4^\circ\text{C} \end{aligned}$$

$$\text{Increase in } T_{m1} \text{ due to regeneration} = 238.8 - 211.4 = 27.4^\circ\text{C} \quad \text{Ans. (b)}$$

$$W_T (\text{without regeneration}) = h_1 - h_3 \\ = 3230.9 - 2192.2 = 1038.7 \text{ kJ/kg}$$

$$\text{Steam rate (without regeneration)} = \frac{3600}{1038.7} = 3.46 \text{ kg/kW h}$$

∴ Increase in steam rate due to regeneration

$$= 3.93 - 3.46 = 0.47 \text{ kg/kW h} \quad \text{Ans. (b)}$$

$$\eta_{\text{cycle}} (\text{without regeneration}) = \frac{h_1 - h_3}{h_1 - h_4} = \frac{1038.7}{3039.07} \\ = 0.3418 \text{ or } 34.18\%$$

∴ Increase in cycle efficiency due to regeneration

$$= 35.36 - 34.18 = 1.18\% \quad \text{Ans. (c)}$$

Example 12.6 In a steam power plant the condition of steam at inlet to the steam turbine is 20 bar and 300°C and the condenser pressure is 0.1 bar. Two feedwater heaters operate at optimum temperatures. Determine: (a) the quality of steam at turbine exhaust, (b) net work per kg of steam, (c) cycle efficiency, and (d) the steam rate. Neglect pump work.

Solution From Fig. 12.19 (a),

$$h_1 = 3023.5 \text{ kJ/kg} \\ s_1 = 6.7664 \text{ kJ/kg K} = s_2 = s_3 = s_4 \\ t_{\text{sat}} \text{ at 20 bar} \cong 212^\circ\text{C} \\ t_{\text{sat}} \text{ at 0.1 bar} \cong 46^\circ\text{C} \\ \Delta t_{\text{OA}} = 212 - 46 = 166^\circ\text{C}$$

$$\therefore \text{Temperature rise per heater} = \frac{166}{3} = 55^\circ\text{C}$$

$$\therefore \text{Temperature at which the first heater operates} \\ = 212 - 55 = 157^\circ\text{C} \cong 150^\circ\text{C (assumed)}$$

$$\text{Temperature at which the second heater operates} = 157 - 55 = 102^\circ\text{C} \cong 100^\circ\text{C (assumed)}$$

At 0.1 bar,

$$h_f = 191.83, h_{fg} = 2392.8, s_f = 0.6493 \\ s_g = 8.1502$$

At 100°C,

$$h_f = 419.04, h_{fg} = 2257.0, s_f = 1.3069, s_g = 7.3549$$

At 150°C,

$$h_f = 632.20, h_{fg} = 2114.3, s_f = 1.8418, s_g = 6.8379 \\ 6.7664 = 1.8418 + x_2 \times 4.9961$$

$$\therefore x_2 = 0.986$$

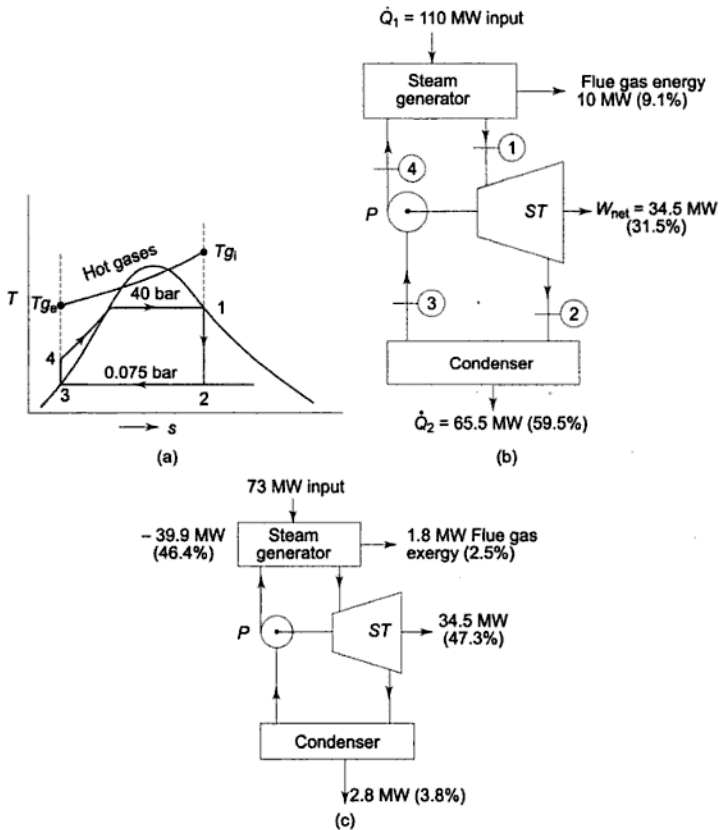

Fig. Ex. 12.7 (a) *T-s* diagram, (b) Energy distribution diagram, (c) Exergy distribution diagram

Solution

$$\dot{Q}_1 = w_g c_{p_g} (T_i - T_e) = 100 \text{ MW}$$

$$w_g = \text{mass flow rate of hot gas}$$

$$= \frac{100 \times 10^3}{1.1 \times (2000 - 450)} = 58.7 \text{ kg/s}$$

Exergy flow rate of inlet gas

$$a_{f_1} = w_g c_{p_g} T_0 \left[\frac{T_i}{T_0} - 1 - \ln \frac{T_i}{T_0} \right]$$

$$= 58.7 \times 1.1 \times 300 \left[\frac{2000}{300} - 1 - \ln \frac{2000}{300} \right]$$

$$= 73 \text{ MW}$$

Exergy flow rate of exhaust gas stream

$$a_{f_2} = 58.7 \times 1.1 \times 300 \left[\frac{450}{300} - 1 - \ln \frac{450}{300} \right] = 1.83 \text{ MW}$$

The exergy loss rate is only about $\left[\frac{1.83}{73} \times 100 \right]$ or 2.5% of the initial exergy of the source gas.

The rate of exergy decrease of the gas stream,

$$a_{f_1} = \text{Exergy input rate} = 73 - 1.83 = 71.17 \approx 71.2 \text{ MW}$$

The rate of exergy increase of steam = Exergy utilization rate

$$a_{f_u} = w_s [h_1 - h_4 - T_0(s_1 - s_4)]$$

Now, $h_1 = (h_g)_{40 \text{ bar}} = 2801 \text{ kJ/kg}$, $h_3 = 169 \text{ kJ/kg}$

$$s_3 = s_4 = 0.576 \text{ kJ/kgK}, h_4 = 172.8 \text{ kJ/kg}$$

$$s_1 = s_2 = 6.068 \text{ kJ/kgK}, h_2 = 1890.2 \text{ kJ/kg}$$

$$W_T = h_1 - h_2 = 2801 - 1890.2 = 910.8 \text{ kJ/kg}$$

$$W_P = h_4 - h_3 = 172.8 - 169 = 3.8 \text{ kJ/kg}$$

$$Q_1 = h_1 - h_4 = 2801 - 172.8 = 2628 \text{ kJ/kg}$$

$$Q_2 = h_2 - h_3 = 1890.2 - 169 = 1721 \text{ kJ/kg}$$

$$W_{\text{net}} = W_T - W_P = Q_1 - Q_2 = 907 \text{ kJ/kg}$$

$$\dot{Q}_1 = w_s \times 2628 = 100 \times 10^3 \text{ kW}$$

$$w_s = 38 \text{ kg/s}$$

$$a_{f_u} = 38 [2801 - 172.8 - 300 (6.068 - 0.576)]$$

$$= 37.3 \text{ MW}$$

Rate of exergy destruction in the steam generator

$$= \text{Rate of exergy decrease of gases} - \text{Rate of exergy increase of steam.}$$

$$\dot{I} = a_{f_1} - a_{f_u} = 71.2 - 37.3 = 33.9 \text{ MW}$$

Rate of useful mechanical power output

$$\dot{W}_{\text{net}} = 38 \times 907 = 34.5 \text{ MW}$$

Exergy flow rate of wet steam to the condenser

$$a_{f_c} = w_s [h_2 - h_3 - T_0(s_2 - s_3)]$$

$$= 38 [1890 - 169 - 300 (6.068 - 0.576)] = 2.8 \text{ MW}$$

This is the exergy loss to the surroundings.

The energy and exergy balances are shown in Fig. Ex. 12.7 (b) and (c). The second law efficiency is given by

$$\eta_{\text{II}} = \frac{\text{Useful exergy output}}{\text{Exergy input}} = \frac{34.5}{73} = 0.473 \text{ or } 47.3\% \quad \text{Ans.}$$

Example 12.8 In a steam power plant, the condition of steam at turbine inlet is 80 bar, 500°C and the condenser pressure is 0.1 bar. The heat source comprises a stream of exhaust gases from a gas turbine discharging at 560°C and 1 atm pressure. The minimum temperature allowed for the exhaust gas stream is 450 K. The mass flow rate of the hot gases is such that the heat input rate to the steam cycle is 100 MW. The ambient condition is given by 300 K and 1 atm. Determine η_I , work ratio and η_{II} of the following cycles: (a) basic Rankine cycle, without superheat, (b) Rankine cycle with superheat, (c) Rankine cycle with reheat such that steam expands in the h.p. turbine until it exits as dry saturated vapour, (d) ideal regenerative cycle, with the exit temperature of the exhaust gas stream taken as 320°C, because the saturation temperature of steam at 80 bar is close to 300°C.

Solution For the first law analysis of each cycle, knowledge of the h values at each of the states indicated in Fig. Ex. 12.8 is required.

(a) *Basic Rankine cycle (Fig. 12.8a):*

By usual procedure with the help of steam tables,

$$h_1 = 2758, h_2 = 1817, h_3 = 192 \text{ and } h_4 = 200 \text{ kJ/kg}$$

$$W_T = h_1 - h_2 = 941 \text{ kJ/kg}, W_P = h_4 - h_3 = 8 \text{ kJ/kg}$$

$$Q_1 = h_1 - h_4 = 2558 \text{ kJ/kg}, W_{\text{net}} = 933 \text{ kJ/kg}$$

$$\eta_I = \frac{W_{\text{net}}}{Q_1} = \frac{933}{2558} = 0.365 \text{ or } 36.5\% \quad \text{Ans.}$$

$$\text{Work ratio} = \frac{W_T - W_P}{W_T} = \frac{933}{941} = 0.991 \quad \text{Ans.}$$

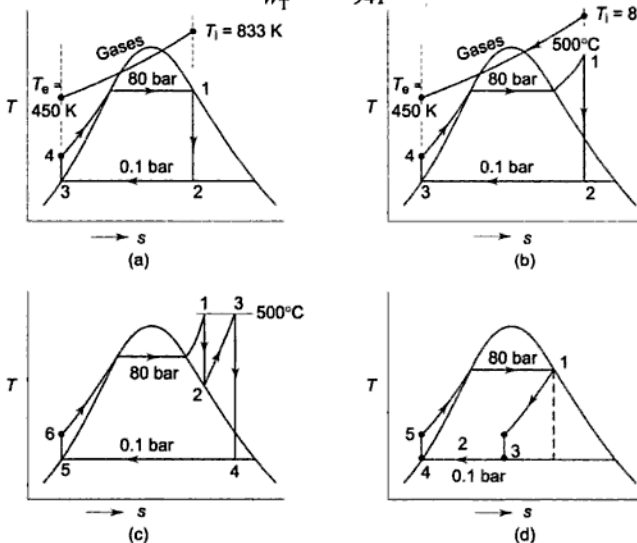

Fig. Ex. 12.8

$$\text{Power output} = \eta_1 Q_1 = 0.365 \times 100 = 36.5 \text{ MW}$$

$$\begin{aligned} \text{Exergy input rate} &= w_g c_{p_g} \left[(T_i - T_0) - T_0 \ln \frac{T_i}{T_0} \right] \\ &= \frac{100 \times 1000}{833 - 450} \left[(833 - 300) - 300 \ln \frac{833}{300} \right] \\ &= 59.3 \text{ MW} \end{aligned}$$

$$\eta_{II} = \frac{36.5}{59.3} = 0.616 \text{ or } 61.6\% \quad \text{Ans.}$$

(b) Rankine cycle with superheat (Fig. 12.8b):

$$h_1 = 3398, h_2 = 2130, h_3 = 192 \text{ and } h_4 = 200 \text{ kJ/kg}$$

$$W_T = 1268 \text{ kJ/kg, } W_P = 8 \text{ kJ/kg, } Q_1 = 3198 \text{ kJ/kg}$$

$$\eta_1 = \frac{1260}{3198} = 0.394 \text{ or } 39.4\% \quad \text{Ans.}$$

$$\text{Work ratio} = \frac{1260}{1268} = 0.994 \quad \text{Ans.}$$

$$\text{Exergy input rate} = 59.3 \text{ MW, } W_{\text{net}} = Q_1 \times \eta_1 = 39.4 \text{ MW}$$

$$\eta_{II} = \frac{36.5}{59.3} = 0.664 \text{ or } 66.4\% \quad \text{Ans.}$$

Improvements in both first law and second law efficiencies are achieved with superheating. The specific work output is also increased. Therefore, conventional vapour power plants are almost always operated with some superheat.

(c) Rankine cycle with reheat (Fig. 12.8c):

$$h_1 = 3398, h_2 = 2761, h_3 = 3482, h_4 = 2522, h_5 = 192 \text{ and } h_6 = 200 \text{ kJ/kg}$$

$$W_{T1} = 637 \text{ kJ/kg, } W_{T2} = 960 \text{ kJ/kg}$$

$$W_T = 637 + 960 = 1597 \text{ kJ/kg, } W_P = 8 \text{ kJ/kg}$$

$$W_{\text{net}} = 1589 \text{ kJ/kg, } Q_1 = 3198 + 721 = 3919 \text{ kJ/kg}$$

$$\eta_1 = \frac{1589}{3919} = 0.405 \text{ or } 40.5\% \quad \text{Ans.}$$

$$\text{Work ratio} = \frac{W_{\text{net}}}{W_T} = \frac{1589}{1597} = 0.995 \quad \text{Ans.}$$

$$\text{Mechanical power output} = 100 \times 0.405 = 40.5 \text{ MW}$$

$$\text{Exergy input rate} = 59.3 \text{ MW}$$

$$\eta_{II} = \frac{40.5}{59.3} = 0.683 \text{ or } 68.3\% \quad \text{Ans.}$$

Compared with basic Rankine cycle, the second law efficiency for the reheat cycle shows an increase of about 11% [(0.683 - 0.616)/0.616]. Therefore, most of the large conventional steam power plants in use today operate on the Rankine cycle with reheat.

(d) Rankine cycle with complete regeneration (Fig. 12.8d)

$$t_{\text{sat}} \text{ at } 0.1 \text{ bar} = 45.8^\circ\text{C} = 318.8 \text{ K and}$$

$$t_{\text{sat}} \text{ at } 80 \text{ bar} = 295^\circ\text{C} = 568 \text{ K}$$

$$\eta_1 = \eta_{\text{Carnot}} = 1 - \frac{T_3}{T_1} = 1 - \frac{318.8}{568.0} = 0.439 \text{ or, } 43.9\% \quad \text{Ans.}$$

$$Q_1 = h_1 - h_6 = 2758 - 1316 = 1442 \text{ kJ/kg}$$

$$W_{\text{net}} = Q_1 \times \eta_1 = 1442 \times 0.439 = 633 \text{ kJ/kg}$$

$$W_p = 8 \text{ kJ/kg} \quad W_T = 641 \text{ kJ/kg}$$

$$\text{Work ratio} = \frac{633}{641} = 0.988 \quad \text{Ans.}$$

$$\text{Power output} = 0.439 \times 100 = 43.9 \text{ MW}$$

$$\begin{aligned} \text{Exergy input rate} &= \frac{100 \times 1000}{833 - 593} \left[(833 - 300) - 300 \ln \frac{833}{300} \right] \\ &= 94.583 \text{ MW} \cong 94.6 \text{ MW} \end{aligned}$$

$$\eta_{\text{II}} = \frac{43.9}{94.6} = 0.464 \text{ or } 46.4\% \quad \text{Ans.}$$

The second law efficiency is lower for regeneration because of the more substantial loss of exergy carried by the effluent gas stream at 593 K.

Example 12.9 A certain chemical plant requires heat from process steam at 120°C at the rate of 5.83 MJ/s and power at the rate of 1000 kW from the generator terminals. Both the heat and power requirements are met by a back pressure turbine of 80% brake and 85% internal efficiency, which exhausts steam at 120°C dry saturated. All the latent heat released during condensation is utilized in the process heater. Find the pressure and temperature of steam at the inlet to the turbine. Assume 90% efficiency for the generator.

Solution At 120°C , $h_{fg} = 2202.6 \text{ kJ/kg} = h_2 - h_3$ (Fig. Ex. 12.9)

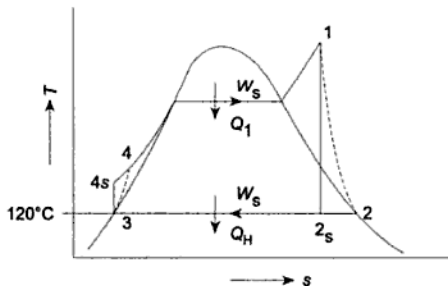

Fig. Ex. 12.9

$$Q_H = w_s(h_2 - h_3) = 5.83 \text{ MJ/s}$$

$$\therefore w_s = \frac{5830}{2202.6} = 2.647 \text{ kg/s}$$

$$W_{\text{net}} = \frac{1000}{0.9} \text{ kJ/s} = \text{Brake output}$$

$$\text{Now } \eta_{\text{brake}} = \frac{\text{Brake output}}{\text{Ideal output}} = \frac{(1000)/0.9}{w_s(h_1 - h_{2s})} = 0.80$$

$$\therefore h_1 - h_{2s} = \frac{1000}{0.9 \times 0.8 \times 2.647} = 524.7 \text{ kJ/kg}$$

$$\text{Again } \eta_{\text{internal}} = \frac{h_1 - h_2}{h_1 - h_{2s}} = 0.85$$

$$\therefore h_1 - h_2 = 0.85 \times 524.7 = 446 \text{ kJ/kg}$$

$$h_2 = h_g \text{ at } 120^\circ\text{C} = 2706.3 \text{ kJ/kg}$$

$$\therefore h_1 = 3152.3 \text{ kJ/kg}$$

$$h_{2s} = h_1 - 524.7 = 2627.6 \text{ kJ/kg}$$

$$= h_f + x_{2s} h_{fg}$$

$$= 503.71 + x_{2s} \times 2202.6$$

$$\therefore x_{2s} = \frac{2123.89}{2202.6} = 0.964$$

$$\therefore s_{2s} = s_f + x_{2s} s_{fg} = 1.5276 + 0.964 \times 5.6020 = 6.928 \text{ kJ/kg K}$$

$$\text{At state 1, } h_1 = 3152.3 \text{ kJ/kg}$$

$$s_1 = 6.928 \text{ kJ/kg K}$$

From the Mollier chart

$$p_1 = 22.5 \text{ bar}$$

$$t_1 = 360^\circ\text{C}$$

Ans.

Example 12.10 A certain factory has an average electrical load of 1500 kW and requires 3.5 MJ/s for heating purpose. It is proposed to install a single-extraction passout steam turbine to operate under the following conditions:

Initial pressure 15 bar.

Initial temperature 300°C .

Condenser pressure 0.1 bar.

Steam is extracted between the two turbines sections at 3 bar, 0.96 dry, and is isobarically cooled without subcooling in heaters to supply the heating load. The internal efficiency of the turbine (in the L.P. Section) is 0.80 and the efficiency of the boiler is 0.85 when using oil of calorific value 44 MJ/kg.

If 10% of boiler steam is used for auxiliaries calculate the oil consumption per day. Assume that the condensate from the heaters (at 3 bar) and that from the condenser (at 0.1 bar) mix freely in a separate vessel (hot well) before being pumped to the boiler. Neglect extraneous losses.

Solution Let w_s be the flow rate of steam (kg/h) entering the turbine, and w the amount of steam extracted per hour for process heat (Fig. Ex. 12.10).

$$h_1 = 3037.3 \text{ kJ/kg}$$

$$h_2 = 561.47 + 0.96 \times 2163.8$$

$$= 2638.7 \text{ kJ/kg}$$

$$s_2 = 1.6718 + 0.96 \times 5.3201$$

$$= 6.7791 \text{ kJ/kg K}$$

$$= s_{3s}$$

$$s_{3s} = 6.7791 = 0.6493 + x_{3s} \times 7.5009$$

$$x_{3s} = \frac{6.1298}{7.5009} = 0.817$$

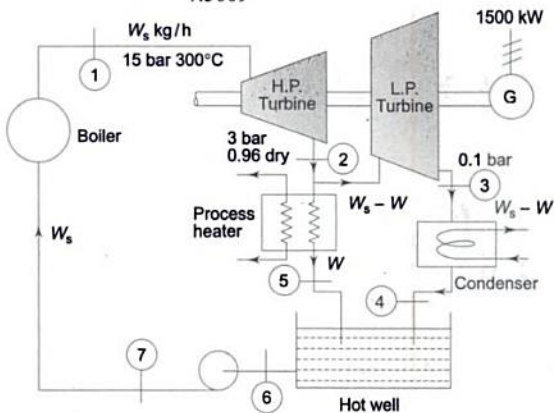

(a)

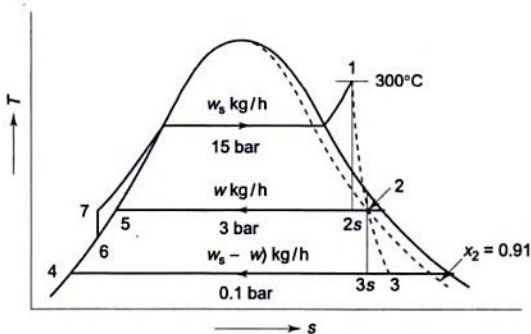

(b)

Fig. Ex. 12.10

$$h_{3s} = 191.83 + 0.817 \times 2392.8 = 2146.75 \text{ kJ/kg}$$

$$h_2 - h_{3s} = 2638.7 - 2146.75 = 491.95 \text{ kJ/kg}$$

$$h_2 - h_3 = 0.8 \times 491.95 = 393.56 \text{ kJ/kg}$$

$$\therefore h_3 = 2638.7 - 393.56 = 2245.14 \text{ kJ/kg}$$

$$h_5 = 561.47 \text{ kJ/kg}, h_4 = 191.83 \text{ kJ/kg}$$

$$Q_H = w(h_2 - h_5) = w(2638.7 - 561.47) = 3.5 \text{ MJ/s}$$

$$\therefore w = \frac{3500}{2077.23} = 1.685 \text{ kg/s}$$

Now

$$\begin{aligned} W_T &= w_s(h_1 - h_2) + (w_s - w)(h_2 - h_3) \\ &= w_s(3037.3 - 2638.7) + (w_s - 1.685) \times 393.56 \\ &= w_s \times 398.6 + w_s \times 393.56 - 663.15 \\ &= 792.16 w_s - 663.15 \end{aligned}$$

Neglecting pump work

$$W_T = 1500 \text{ kJ/s} = 792.16 w_s - 663.15$$

$$\therefore w_s = \frac{2163.15}{792.16} = 2.73 \text{ kg/s} = 9828 \text{ kg/h}$$

By making energy balance for the hot well

$$\begin{aligned} (w_s - w)h_4 + wh_5 &= w_s h_6 \\ (2.73 - 1.685)191.83 + 1.685 \times 561.47 &= 2.73 \times h_6 \\ 200.46 + 946.08 &= 2.73 h_6 \end{aligned}$$

$$\therefore h_6 = 419.98 \text{ kJ/kg} \cong h_7$$

Steam raising capacity of the boiler = $1.1 w_s$ kg/h, since 10% of boiler steam is used for auxiliaries.

$$\therefore \eta_{\text{boiler}} = \frac{1.1 w_s (h_1 - h_7)}{w_f \times \text{C.V.}}$$

where w_f = fuel burning rate (kg/h)

and C.V. = calorific value of fuel = 44 MJ/kg

$$\therefore 0.85 = \frac{1.1 \times 9828 \times (3037.3 - 419.98)}{w_f \times 44000}$$

$$\text{or } w_f = \frac{1.1 \times 9828 \times 2617.32}{0.85 \times 44000} = 756.56 \text{ kg/h}$$

$$= \frac{756.56 \times 24}{1000} = 18.16 \text{ tonnes/day} \quad \text{Ans.}$$

Example 12.11 A steam turbine gets its supply of steam at 70 bar and 450°C. After expanding to 25 bar in high pressure stages, it is reheated to 420°C at the constant pressure. Next, it is expanded in intermediate pressure stages to an appropriate minimum pressure such that part of the steam bled at this pressure

heats the feedwater to a temperature of 180°C . The remaining steam expands from this pressure to a condenser pressure of 0.07 bar in the low pressure stage. The isentropic efficiency of the h.p. stage is 78.5% , while that of the intermediate and l.p. stages is 83% each. From the above data (a) determine the minimum pressure at which bleeding is necessary, and sketch a line diagram of the arrangement of the plant, (b) sketch on the T - s diagram all the processes, (c) determine the quantity of steam bled per kg of flow at the turbine inlet, and (d) calculate the cycle efficiency. Neglect pump work.

Solution Figure Ex. 12.11 gives the flow and T - s diagrams of the plant. It would be assumed that the feedwater heater is an open heater. Feedwater is heated to 180°C . So p_{sat} at $180^{\circ}\text{C} \cong 10\text{ bar}$ is the pressure at which the heater operates.

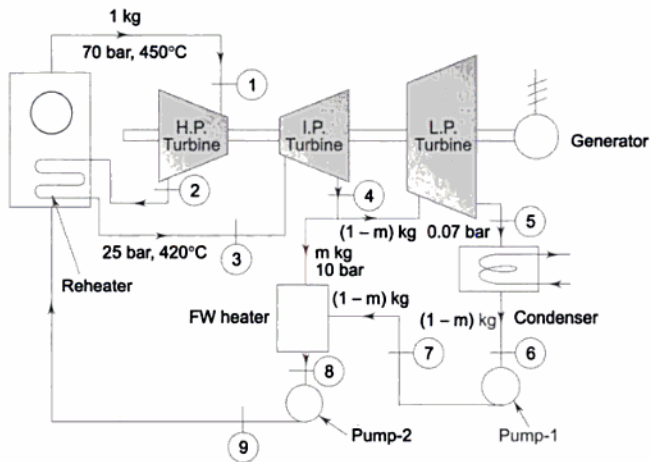

(a)

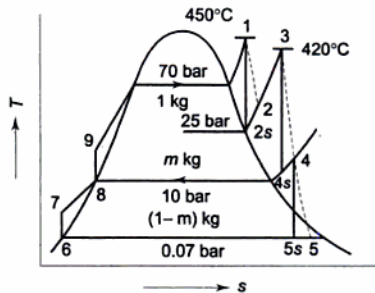

(b)

Fig. Ex. 12.11

Therefore, the pressure at which bleeding is necessary is 10 bar. *Ans. (a).*
From the Mollier chart

$$h_1 = 3285, h_{2s} = 3010, h_3 = 3280, h_{4s} = 3030 \text{ kJ/kg}$$

$$h_3 - h_4 = 0.83 (h_3 - h_{4s}) = 0.83 \times 250 = 207.5 \text{ kJ/kg}$$

$$h_4 = 3280 - 207.5 = 3072.5 \text{ kJ/kg}$$

$$h_{5s} = 2225 \text{ kJ/kg}$$

$$h_4 - h_5 = 0.83(h_4 - h_{5s}) = 0.83 \times 847.5 = 703.4 \text{ kJ/kg}$$

$$\therefore h_5 = 3072.5 - 703.4 = 2369.1 \text{ kJ/kg}$$

$$h_6 = 162.7 \text{ kJ/kg}$$

$$h_8 = 762.81 \text{ kJ/kg}$$

$$h_1 - h_2 = 0.785 (h_1 - h_{2s}) = 0.785 \times 275 = 215.9 \text{ kJ/kg}$$

$$h_2 = 3285 - 215.9 = 3069.1 \text{ kJ/kg}$$

Energy balance for the heater gives

$$m \times h_4 + (1 - m)h_7 = 1 \times h_8$$

$$m \times 3072.5 + (1 - m) \times 162.7 = 1 \times 762.81$$

$$m = \frac{600.11}{2909.8} = 0.206 \text{ kg/kg steam flow at turbine inlet.}$$

Ans. (c)

$$\therefore \eta_{\text{cycle}} = \frac{(h_1 - h_2) + (h_3 - h_4) + (1 - m)(h_4 - h_5)}{(h_1 - h_8) + (h_3 - h_2)}$$

$$= \frac{215.9 + 207.5 + 0.794 \times 703.4}{2522.2 + 210.9}$$

$$= \frac{981.9}{2733.1} = 0.3592 \text{ or } 35.92\%$$

Ans. (d)

Example 12.12 A binary-vapour cycle operates on mercury and steam. Saturated mercury vapour at 4.5 bar is supplied to the mercury turbine, from which it exhausts at 0.04 bar. The mercury condenser generates saturated steam at 15 bar which is expanded in a steam turbine to 0.04 bar. (a) Find the overall efficiency of the cycle. (b) If 50,000 kg/h of steam flows through the steam turbine, what is the flow through the mercury turbine? (c) Assuming that all processes are reversible, what is the useful work done in the binary vapour cycle for the specified steam flow? (d) If the steam leaving the mercury condenser is superheated to a temperature of 300°C in a superheater located in the mercury boiler, and if the internal efficiencies of the mercury and steam turbines are 0.85 and 0.87 respectively, calculate the overall efficiency of the cycle. The properties of saturated mercury are given below

p (bar)	t (°C)	h_f	h_g	s_f	s_g	v_f	v_g
		(kJ/kg)		(kJ/kg K)		(m ³ /kg)	
4.5	450	62.93	355.98	0.1352	0.5397	79.9×10^{-6}	0.068
0.04	216.9	29.98	329.85	0.0808	0.6925	76.5×10^{-6}	5.178

Solution The cycle is shown in Fig. Ex. 12.12.

For the mercury cycle, $h_a = 355.98 \text{ kJ/kg}$

$$\begin{aligned} s_a &= 0.5397 \text{ kJ/kg K} = s_b = s_f + x_b s_{fg} \\ &= 0.0808 + x_b (0.6925 - 0.0808) \end{aligned}$$

$$\therefore x_b = \frac{0.4589}{0.6117} = 0.75$$

$$h_b = 29.98 + 0.75 \times 299.87 = 254.88 \text{ kJ/kg}$$

$$(W_T)_m = h_a - h_b = 355.98 - 254.88 = 101.1 \text{ kJ/kg}$$

$$(W_P)_m = h_d - h_c = 76.5 \times 10^{-6} \times 4.46 \times 100 = 3.41 \times 10^{-2} \text{ kJ/kg}$$

$$\therefore W_{\text{net}} = 101.1 \text{ kJ/kg}$$

$$Q_1 = h_a - h_d = 355.98 - 29.98 = 326 \text{ kJ/kg}$$

$$\therefore \eta_m = \frac{W_{\text{net}}}{Q_1} = \frac{101.1}{326} = 0.31 \text{ or } 31\%$$

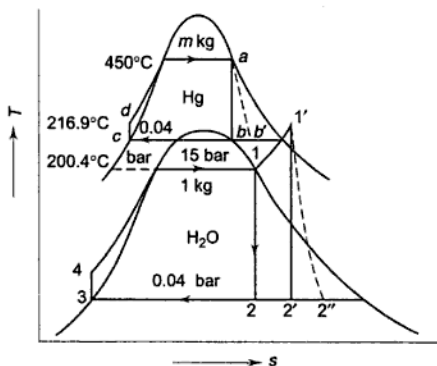

Fig. Ex. 12.12

For the steam cycle

$$h_1 = 2792.2 \text{ kJ/kg}$$

$$\begin{aligned} s_1 &= 6.4448 \text{ kJ/kg K} = s_2 = s_f + x_2 s_{fg2} \\ &= 0.4226 + x_2 (8.4746 - 0.4226) \end{aligned}$$

$$x_2 = \frac{6.0222}{8.0520} = 0.748$$

$$h_2 = 121.46 + 0.748 \times 2432.9 = 1941.27 \text{ kJ/kg}$$

$$\begin{aligned} (W_T)_{St} &= h_1 - h_2 = 2792.2 - 1941.27 \\ &= 850.93 \text{ kJ/kg} \end{aligned}$$

$$(W_P)_{St} = h_4 - h_3 = 0.001 \times 14.96 \times 100 = 1.496 \text{ kJ/kg} \cong 1.5 \text{ kJ/kg}$$

$$h_4 = 121.46 + 1.5 = 122.96 \text{ kJ/kg}$$

$$Q_1 = h_1 - h_4 = 2792.2 - 122.96 = 2669.24 \text{ kJ/kg}$$

$$(W_{\text{net}})_{\text{St}} = 850.93 - 1.5 = 849.43 \text{ kJ/kg}$$

$$\therefore \eta_{\text{st}} = \frac{W_{\text{net}}}{Q_1} = \frac{849.43}{2669.24} = 0.318 \text{ or } 31.8\%$$

Overall efficiency of the binary cycle would be

$$\begin{aligned} \eta_{\text{overall}} &= \eta_m + \eta_{\text{St}} - \eta_m \cdot \eta_{\text{St}} \\ &= 0.31 + 0.318 - 0.31 \times 0.318 \\ &= 0.5294 \text{ or } 52.94\% \end{aligned}$$

Ans. (a)

η_{overall} can also be determined in the following way:

By writing the energy balance for a mercury condenser-steam boiler

$$m(h_b - h_c) = 1(h_1 - h_4)$$

where m is the amount of mercury circulating for 1 kg of steam in the bottom cycle.

$$\therefore m = \frac{h_1 - h_4}{h_b - h_c} = \frac{2669.24}{254.88 - 29.88} = \frac{2669.24}{224.90} = 11.87 \text{ kg}$$

$$(Q_1)_{\text{total}} = m(h_a - h_d) = 11.87 \times 326 = 3869.6 \text{ kJ/kg}$$

$$\begin{aligned} (W_T)_{\text{total}} &= m(h_a - h_b) + (h_1 - h_2) \\ &= 11.87 \times 101.1 + 850.93 = 2051 \text{ kJ/kg} \end{aligned}$$

$(W_P)_{\text{total}}$ may be neglected

$$\therefore \eta_{\text{overall}} = \frac{W_{\text{net}}}{Q_1} = \frac{2051}{3869.6} = 0.53 \text{ or } 53\%$$

If 50,000 kg/h of steam flows through the steam turbine, the flow rate of mercury w_m would be

$$w_m = 50,000 \times 11.87 = 59.35 \times 10^4 \text{ kg/h} \quad \text{Ans. (b)}$$

$$\begin{aligned} (W_T)_{\text{total}} &= 2051 \times 50,000 = 10255 \times 10^4 \text{ kJ/h} \\ &= 0.2849 \times 10^5 \text{ kW} = 28.49 \text{ MW} \end{aligned} \quad \text{Ans. (c)}$$

Considering the efficiencies of turbines

$$(W_T)_m = h_a - h'_b = 0.85 \times 101.1 = 85.94 \text{ kJ/kg}$$

$$\therefore h'_b = 355.98 - 85.94 = 270.04 \text{ kJ/kg}$$

$$\therefore m'(h'_b - h'_c) = (h_1 - h_4)$$

$$\therefore m' = \frac{2669.24}{240.06} = 11.12 \text{ kg}$$

$$\begin{aligned} (Q_1)_{\text{total}} &= m'(h_a - h_d) + 1(h'_1 - h_1) \\ &= 11.12 \times 326 + (3037.3 - 2792.2) \\ &= 3870.22 \text{ kJ/kg} \end{aligned}$$

$$s'_1 = 6.9160 = 0.4226 + x'_2(8.4746 - 0.4226)$$

$$x'_2 = \frac{6.4934}{8.0520} = 0.806$$

$$h'_2 = 121.46 + 0.806 \times 2432.9 = 2082.38 \text{ kJ/kg}$$

$$(W_T)_{St} = h_1 - h'_2 = 0.87(3037.3 - 2082.38) \\ = 830.78 \text{ kJ/kg}$$

$$(W_T)_{total} = 11.12 \times 85.94 + 830.78 \\ = 1786.43 \text{ kJ/kg}$$

Pump work is neglected.

$$\eta_{overall} = \frac{1786.43}{3870.22} = 0.462 \text{ or } 46.2\% \quad \text{Ans. (d)}$$

REVIEW QUESTIONS

- 12.1 What are the four basic components of a steam power plant?
- 12.2 What is the reversible cycle that represents the simple steam power plant? Draw the flow, p - v , T - s and h - s diagrams of this cycle.
- 12.3 What do you understand by steam rate and heat rate? What are their units?
- 12.4 Why is Carnot cycle not practicable for a steam power plant?
- 12.5 What do you understand by the mean temperature of heat addition?
- 12.6 For a given T_2 , show how the Rankine cycle efficiency depends on the mean temperature of heat addition.
- 12.7 What is metallurgical limit?
- 12.8 Explain how the quality at turbine exhaust gets restricted.
- 12.9 How are the maximum temperature and maximum pressure in the Rankine cycle fixed?
- 12.10 When is reheating of steam recommended in a steam power plant? How does the reheat pressure get optimized?
- 12.11 What is the effect of reheat on (a) the specific output, (b) the cycle efficiency, (c) steam rate, and (d) heat rate, of a steam power plant?
- 12.12 Give the flow and T - s diagrams of the ideal regenerative cycle. Why is the efficiency of this cycle equal to Carnot efficiency? Why is this cycle not practicable?
- 12.13 What is the effect of regeneration on the (a) specific output, (b) mean temperature of heat addition, (c) cycle efficiency, (d) steam rate and (e) heat rate of a steam power plant?
- 12.14 How does the regeneration of steam carnotize the Rankine cycle?
- 12.15 What are open and closed heaters? Mention their merits and demerits.
- 12.16 Why is one open feedwater heater used in a steam plant? What is it called?
- 12.17 How are the number of heaters and the degree of regeneration get optimized?
- 12.18 Draw the T - s diagram of an ideal working fluid in a vapour power cycle.
- 12.19 Discuss the desirable characteristics of a working fluid in a vapour power cycle.
- 12.20 Mention a few working fluids suitable in the high temperature range of a vapour power cycle.
- 12.21 What is a binary vapour cycle?
- 12.22 What are topping and bottoming cycles?
- 12.23 Show that the overall efficiency of two cycles coupled in series equals the sum of the individual efficiencies minus their product.

- 12.24 What is a cogeneration plant? What are the thermodynamic advantages of such a plant?
- 12.25 What is a back pressure turbine? What are its applications?
- 12.26 What is the biggest loss in a steam plant? How can this loss be reduced?
- 12.27 What is a pass-out turbine? When is it used?
- 12.28 Define the following: (a) internal work, (b) internal efficiency, (c) brake efficiency (d) mechanical efficiency, and (e) boiler efficiency.
- 12.29 Express the overall efficiency of a steam plant as the product of boiler, turbine, generator and cycle efficiencies.

PROBLEMS

- 12.1 For the following steam cycles, find (a) W_T in kJ/kg (b) W_p in kJ/kg, (c) Q_1 in kJ/kg, (d) cycle efficiency, (e) steam rate in kg/kW h, and (f) moisture at the end of the turbine process. Show the results in tabular form with your comments.

<i>Boiler outlet</i>	<i>Condenser Pressure</i>	<i>Type of Cycle</i>
10 bar, saturated	1 bar	Ideal Rankine Cycle
-do-	-do-	Neglect W_p
-do-	-do-	Assume 75% pump and turbine efficiency
-do-	0.1 bar	Ideal Rankine Cycle
10 bar, 300°C	-do-	-do-
150 bar, 600°C	-do-	-do-
-do-	-do-	Reheat to 600°C at maximum intermediate pressure to limit end moisture to 15%
-do-	-do-	-do- but with 85% turbine efficiency
10 bar, saturated	0.1 bar	Isentropic pump process ends on saturated liquid line
-do-	-do-	-do- but with 80% machine efficiencies
-do-	-do-	Ideal regenerative cycle
-do-	-do-	Single open heater at 110°C
-do-	-do-	Two open heaters at 90°C and 135°C
-do-	-do-	-do- but the heaters are closed heaters

- 12.2 A geothermal power plant utilizes steam produced by natural means underground. Steam wells are drilled to tap this steam supply which is available at 4.5 bar and 175°C. The steam leaves the turbine at 100 mm Hg absolute pressure. The turbine isentropic efficiency is 0.75. Calculate the efficiency of the plant. If the unit produces 12.5 MW, what is the steam flow rate?

- 12.3 A simple steam power cycle uses solar energy for the heat input. Water in the cycle enters the pump as a saturated liquid at 40°C , and is pumped to 2 bar. It then evaporates in the boiler at this pressure, and enters the turbine as saturated vapour. At the turbine exhaust the conditions are 40°C and 10% moisture. The flow rate is 150 kg/h. Determine (a) the turbine isentropic efficiency, (b) the net work output (c) the cycle efficiency, and (d) the area of solar collector needed if the collectors pick up 0.58 kW/m^2 .

Ans. (a) 0.767, (b) 15.51 kW, (c) 14.7%, (d) 182.4 m^2

- 12.4 In a reheat cycle, the initial steam pressure and the maximum temperature are 150 bar and 550°C respectively. If the condenser pressure is 0.1 bar and the moisture at the condenser inlet is 5%, and assuming ideal processes, determine (a) the reheat pressure, (b) the cycle efficiency, and (c) the steam rate.

Ans. 13.5 bar, 43.6%, 2.05 kg/kW h

- 12.5 In a nuclear power-plant heat is transferred in the reactor to liquid sodium. The liquid sodium is then pumped to a heat exchanger where heat is transferred to steam. The steam leaves this heat exchanger as saturated vapour at 55 bar, and is then superheated in an external gas-fired superheater to 650°C . The steam then enters the turbine, which has one extraction point at 4 bar, where steam flows to an open feedwater heater. The turbine efficiency is 75% and the condenser temperature is 40°C . Determine the heat transfer in the reactor and in the superheater to produce a power output of 80 MW.

- 12.6 In a reheat cycle, steam at 500°C expands in a h.p. turbine till it is saturated vapour. It is reheated at constant pressure to 400°C and then expands in a l.p. turbine to 40°C . If the maximum moisture content at the turbine exhaust is limited to 15%, find (a) the reheat pressure, (b) the pressure of steam at the inlet to the h.p. turbine, (c) the net specific work output, (d) the cycle efficiency, and (e) the steam rate. Assume all ideal processes.

What would have been the quality, the work output, and the cycle efficiency without the reheating of steam? Assume that the other conditions remain the same.

- 12.7 A regenerative cycle operates with steam supplied at 30 bar and 300°C , and condenser pressure of 0.08 bar. The extraction points for two heaters (one closed and one open) are at 3.5 bar and 0.7 bar respectively. Calculate the thermal efficiency of the plant, neglecting pump work.
- 12.8 The net power output of the turbine in an ideal reheat-regenerative cycle is 100 MW. Steam enters the high-pressure (H.P.) turbine at 90 bar, 550°C . After expansion to 7 bar, some of the steam goes to an open heater and the balance is reheated to 400°C , after which it expands to 0.07 bar. (a) What is the steam flow rate to the H.P. turbine? (b) What is the total pump work? (c) Calculate the cycle efficiency. (d) If there is a 10°C rise in the temperature of the cooling water, what is the rate of flow of the cooling water in the condenser? (e) If the velocity of the steam flowing from the turbine to the condenser is limited to a maximum of 130 m/s, find the diameter of the connecting pipe.
- 12.9 A mercury cycle is superposed on the steam cycle operating between the boiler outlet condition of 40 bar, 400°C and the condenser temperature of 40°C . The heat released by mercury condensing at 0.2 bar is used to impart the latent heat of vaporization to the water in the steam cycle. Mercury enters the mercury turbine

as saturated vapour at 10 bar. Compute (a) kg of mercury circulated per kg of water, and (b) the efficiency of the combined cycle.

The property values of saturated mercury are given below

p (bar)	t ($^{\circ}\text{C}$)	h_f (kJ/kg)	h_g (kJ/kg)	s_f (kJ/kg K)	s_g (kJ/kg K)	v_f (m^3/kg)	v_g (m^3/kg)
10	515.5	72.23	363.0	0.1478	0.5167	80.9×10^{-6}	0.0333
0.2	277.3	38.35	336.55	0.0967	0.6385	77.4×10^{-6}	1.163

- 12.10 In an electric generating station, using a binary vapour cycle with mercury in the upper cycle and steam in the lower, the ratio of mercury flow to steam flow is 10 : 1 on a mass basis. At an evaporation rate of 1,000,000 kg/h for the mercury, its specific enthalpy rises by 356 kJ/kg in passing through the boiler. Superheating the steam in the boiler furnace adds 586 kJ to the steam specific enthalpy. The mercury gives up 251.2 kJ/kg during condensation, and the steam gives up 2003 kJ/kg in its condenser. The overall boiler efficiency is 85%. The combined turbine mechanical and generator efficiencies are each 95% for the mercury and steam units. The steam auxiliaries require 5% of the energy generated by the units. Find the overall efficiency of the plant.
- 12.11 A sodium-mercury-steam cycle operates between 1000 $^{\circ}\text{C}$ and 40 $^{\circ}\text{C}$. Sodium rejects heat at 670 $^{\circ}\text{C}$ to mercury. Mercury boils at 24.6 bar and rejects heat at 0.141 bar. Both the sodium and mercury cycles are saturated. Steam informed at 30 bar and is superheated in the sodium boiler to 350 $^{\circ}\text{C}$. It rejects heat at 0.08 bar. Assume isentropic expansions, no heat losses, and no regeneration and neglect pumping work. Find (a) the amounts of sodium and mercury used per kg of steam, (b) the heat added and rejected in the composite cycle per kg steam, (c) the total work done per kg steam. (d) the efficiency of the composite cycle, (e) the efficiency of the corresponding Carnot cycle, and (f) the work, heat added, and efficiency of a supercritical pressure steam (single fluid) cycle operating at 250 bar and between the same temperature limits.

For mercury, at 24.6 bar, $h_g = 366.78$ kJ/kg

$$s_g = 0.48 \text{ kJ/kg K and at } 0.141 \text{ bar, } s_f = 0.09$$

and

$$s_g = 0.64 \text{ kJ/kg K, } h_f = 36.01 \text{ and } h_g = 330.77 \text{ kJ/kg}$$

For sodium, at 1000 $^{\circ}\text{C}$, $h_g = 4982.53$ kJ/kg

At turbine exhaust, $h = 3914.85$ kJ/kg

At 670 $^{\circ}\text{C}$, $h_f = 745.29$ kJ/kg

For a supercritical steam cycle, the specific enthalpy and entropy at the turbine inlet may be computed by extrapolation from the steam tables.

- 12.12 A textile factory requires 10,000 kg/h of steam for process heating at 3 bar saturated and 1000 kW of power, for which a back pressure turbine of 70% internal efficiency is to be used. Find the steam condition required at the inlet to the turbine.
- 12.13 A 10,000 kW steam turbine operates with steam at the inlet at 40 bar, 400 $^{\circ}\text{C}$ and exhausts at 0.1 bar. Ten thousand kg/h of steam at 3 bar are to be extracted for process work. The turbine has 75% isentropic efficiency throughout. Find the boiler capacity required.
- 12.14 A 50 MW steam plant built in 1935 operates with steam at the inlet at 60 bar, 450 $^{\circ}\text{C}$ and exhausts at 0.1 bar, with 80% turbine efficiency. It is proposed to

(b) the work done in the turbines.

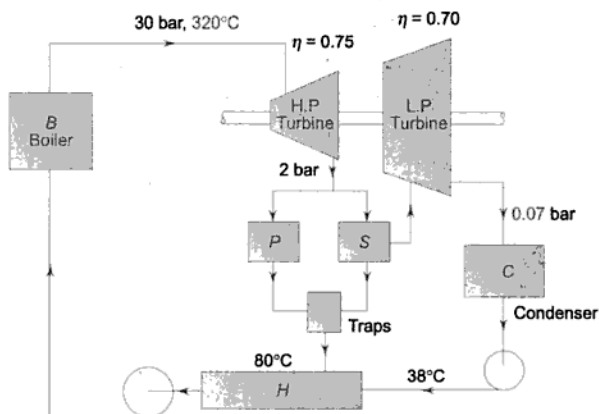

Fig. P 12.18

- 12.19 In a combined power and process plant the boiler generates 21,000 kg/h of steam at a pressure of 17 bar, and temperature 230°C. A part of the steam goes to a process heater which consumes 132.56 kW, the steam leaving the process heater 0.957 dry at 17 bar being throttled to 3.5 bar. The remaining steam flows through a H.P. turbine which exhausts at a pressure of 3.5 bar. The exhaust steam mixes with the process steam before entering the L.P. turbine which develops 1337.5 kW. At the exhaust the pressure is 0.3 bar, and the steam is 0.912 dry. Draw a line diagram of the plant and determine (a) steam quality at the exhaust from the H.P. turbine, (b) the power developed by the H.P. turbine, and (c) the isentropic efficiency of the H.P. turbine.

Ans. (a) 0.96, (b) 1125 kW, (c) 77%

- 12.20 In a cogeneration plant, the power load is 5.6 MW and the heating load is 1.163 MW. Steam is generated at 40 bar and 500°C and is expanded isentropically through a turbine to a condenser at 0.06 bar. The heating load is supplied by extracting steam from the turbine at 2 bar which condensed in the process heater to saturated liquid at 2 bar and then pumped back to the boiler. Compute (a) the steam generation capacity of the boiler in tonnes/h, (b) the heat input to the boiler in MW, and (c) the heat rejected to the condenser in MW.

Ans. (a) 19.07 t/h, (b) 71.57 MW, and (c) 9.607 MW

- 12.21 Steam is supplied to a pass-out turbine at 35 bar, 350°C and dry saturated process steam is required at 3.5 bar. The low pressure stage exhausts at 0.07 bar and the condition line may be assumed to be straight (the condition line is the locus passing through the states of steam leaving the various stages of the turbine). If the power required is 1 MW and the maximum process load is 1.4 kW, estimate the maximum steam flow through the high and low pressure stages. Assume that the steam just condenses in the process plant.

Ans. 1.543 and 1.182 kg/s

- 12.22 Geothermal energy from a natural geyser can be obtained as a continuous supply of steam 0.87 dry at 2 bar and at a flow rate of 2700 kg/h. This is utilized in a mixed-pressure cycle to augment the superheated exhaust from a high pressure turbine of 83% internal efficiency, which is supplied with 5500 kg/h of steam at 40 bar and 500°C. The mixing process is adiabatic and the mixture is expanded to a condenser pressure of 0.10 bar in a low pressure turbine of 78% internal efficiency. Determine the power output and the thermal efficiency of the plant.
Ans. 1745 kW, 35%
- 12.23 In a study for a space project it is thought that the condensation of a working fluid might be possible at -40°C. A binary cycle is proposed, using Refrigerant-12 as the low temperature fluid, and water as the high temperature fluid. Steam is generated at 80 bar, 500°C and expands in a turbine of 81% isentropic efficiency to 0.06 bar, at which pressure it is condensed by the generation of dry saturated refrigerant vapour at 30°C from saturated liquid at -40°C. The isentropic efficiency of the R-12 turbine is 83%. Determine the mass ratio of R-12 to water and the efficiency of the cycle. Neglect all losses.
Ans. 10.86; 44.4%
- 12.24 Steam is generated at 70 bar, 500°C and expands in a turbine to 30 bar with an isentropic efficiency of 77%. At this condition it is mixed with twice its mass of steam at 30 bar, 400°C. The mixture then expands with an isentropic efficiency of 80% to 0.06 bar. At a point in the expansion where the pressure is 5 bar, steam is bled for feedwater heating in a direct contact heater, which raises the feedwater to the saturation temperature of the bled steam. Calculate the mass of steam bled per kg of high pressure steam and the cycle efficiency. Assume that the L.P. expansion condition line is straight.
Ans. 0.53 kg; 31.9%
- 12.25 An ideal steam power plant operates between 70 bar, 550°C and 0.075 bar. It has seven feedwater heaters. Find the optimum pressure and temperature at which each of the heaters operate.
- 12.26 In a reheat cycle steam at 550°C expands in an h.p. turbine till it is saturated vapour. It is reheated at constant pressure to 400°C and then expands in a l.p. turbine to 40°C. If the moisture content at turbine exhaust is given to be 14.67%, find (a) the reheat pressure, (b) the pressure of steam at inlet to the h.p. turbine, (c) the net work output per kg, and (d) the cycle efficiency. Assume all processes to be ideal.
Ans. (a) 20 bar, (b) 200 bar, (c) 1604 kJ/kg, (d) 43.8%
- 12.27 In a reheat steam cycle, the maximum steam temperature is limited to 500°C. The condenser pressure is 0.1 bar and the quality at turbine exhaust is 0.8778. Had there been no reheat, the exhaust quality would have been 0.7592. Assuming ideal processes, determine (a) the reheat pressure, (b) the boiler pressure, (c) the cycle efficiency, and (d) the steam rate.
Ans. (a) 30 bar, (b) 150 bar, (c) 50.51%, (d) 1.9412 kg/kWh
- 12.28 In a cogeneration plant, steam enters the h.p. stage of a two-stage turbine at 1 MPa, 200°C and leaves it at 0.3 MPa. At this point some of the steam is bled off and passed through a heat exchanger which it leaves as saturated liquid at 0.3 MPa. The remaining steam expands in the l.p. stage of the turbine to 40 kPa. The turbine is required to produce a total power of 1 MW and the heat exchanger to provide a heating rate of 500 KW. Calculate the required mass flow rate of

Gas Power Cycles

Here gas is the working fluid. It does not undergo any phase change. Engines operating on gas cycles may be either cyclic or non-cyclic. Hot air engines using air as the working fluid operate on a closed cycle. Internal combustion engines where the combustion of fuel takes place inside the engine cylinder are non-cyclic heat engines.

13.1 Carnot Cycle (1824)

The Carnot cycle (Fig. 13.1) has been discussed in Chapters 6 and 7. It consists of:

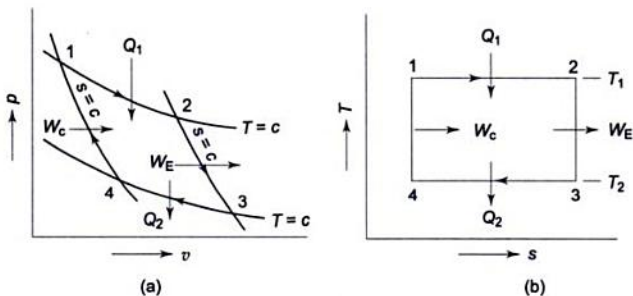

Fig. 13.1 Carnot cycle

Two reversible isotherms and two reversible adiabatics. If an ideal gas is assumed as the working fluid, then for 1 kg of gas

$$Q_{1-2} = RT_1 \ln \frac{v_2}{v_1}; \quad W_{1-2} = RT_1 \ln \frac{v_2}{v_1}$$

$$Q_{2-3} = 0; \quad W_{2-3} = -c_v (T_3 - T_2)$$

$$Q_{3-4} = RT_2 \ln \frac{v_4}{v_3}; W_{3-4} = RT_2 \ln \frac{v_4}{v_3}$$

$$Q_{4-1} = 0; W_{4-1} = -c_v(T_1 - T_4)$$

$$\therefore \sum_{\text{cycle}} dQ = \sum_{\text{cycle}} dW$$

Now

$$\frac{v_2}{v_3} = \left(\frac{T_2}{T_1} \right)^{1/(\gamma-1)}$$

and

$$\frac{v_1}{v_4} = \left(\frac{T_2}{T_1} \right)^{1/(\gamma-1)}$$

\therefore

$$\frac{v_2}{v_3} = \frac{v_1}{v_4} \text{ or } \frac{v_2}{v_1} = \frac{v_3}{v_4}$$

Therefore

$$Q_1 = \text{Heat added} = RT_1 \ln \frac{v_2}{v_1}$$

$$W_{\text{net}} = Q_1 - Q_2 = R \ln \frac{v_2}{v_1} \cdot (T_1 - T_2)$$

\therefore

$$\eta_{\text{cycle}} = \frac{W_{\text{net}}}{Q_1} = \frac{T_1 - T_2}{T_1} \quad (13.1)$$

The large back work ($W_c = W_{4-1}$) is a big drawback for the Carnot gas cycle, as in the case of the Carnot vapour cycle.

13.2 Stirling Cycle (1827)

The Stirling cycle (Fig. 13.2) consists of:

Two reversible isotherms and two reversible isochores. For 1 kg of ideal gas

$$Q_{1-2} = W_{1-2} = RT_1 \ln \frac{v_2}{v_1}$$

$$Q_{2-3} = -c_v(T_2 - T_1); W_{2-3} = 0$$

$$Q_{3-4} = W_{3-4} = -RT_2 \ln \frac{v_3}{v_4}$$

$$Q_{4-1} = c_v(T_1 - T_2); W_{4-1} = 0$$

Due to heat transfers at constant volume processes, the efficiency of the Stirling cycle is less than that of the Carnot cycle. However, if a regenerative arrangement is used such that

$Q_{2-3} = Q_{4-1}$, i.e., the area under 2-3 is equal to the area under 4-1, then the cycle efficiency becomes

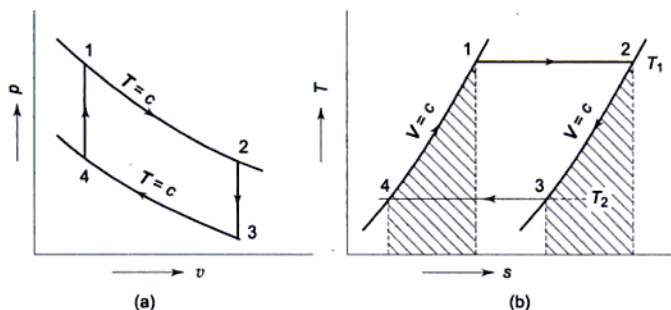

Fig. 13.2 Stirling cycle

$$\eta = \frac{RT_1 \ln \frac{v_2}{v_1} - RT_2 \ln \frac{v_3}{v_4}}{RT_1 \ln \frac{v_2}{v_1}} = \frac{T_1 - T_2}{T_1} \quad (13.2)$$

So, the regenerative Stirling cycle has the same efficiency as the Carnot cycle.

13.3 Ericsson Cycle (1850)

The Ericsson cycle (Fig. 13.3) is made up of:

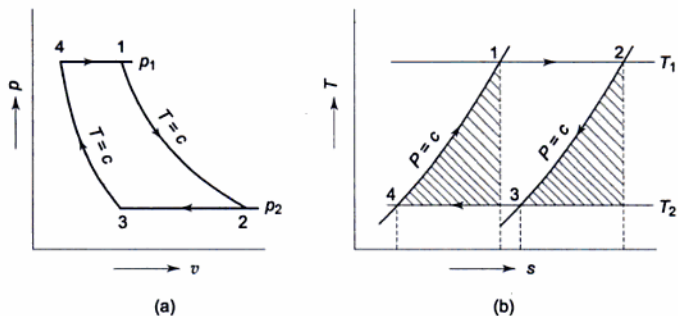

Fig. 13.3 Ericsson cycle

Two reversible isotherms and two reversible isobars.

For 1 kg of ideal gas

$$Q_{1-2} = W_{1-2} = RT_1 \ln \frac{p_1}{p_2}$$

$$Q_{2-3} = c_p(T_2 - T_1); W_{2-3} = p_2(v_3 - v_2) = R(T_2 - T_1)$$

$$Q_{3-4} = W_{3-4} = -RT_2 \ln \frac{p_1}{p_2}$$

$$Q_{4-1} = c_p(T_1 - T_4); W_{4-1} = p_1(v_1 - v_4) = R(T_1 - T_2)$$

Since part of the heat is transferred at constant pressure and part at constant temperature, the efficiency of the Ericsson cycle is less than that of the Carnot cycle. But with ideal regeneration, $Q_{2-3} = Q_{4-1}$ so that all the heat is added from the external source at T_1 and all the heat is rejected to an external sink at T_2 , the efficiency of the cycle becomes equal to the Carnot cycle efficiency, since

$$\eta = 1 - \frac{Q_2}{Q_1} = 1 - \frac{RT_2 \ln \frac{p_1}{p_2}}{RT_1 \ln \frac{p_1}{p_2}} = 1 - \frac{T_2}{T_1} \quad (13.3)$$

The regenerative, Stirling and Ericsson cycles have the same efficiency as the Carnot cycle, but much less back work. Hot air engines working on these cycles have been successfully operated. But it is difficult to transfer heat to a gas at high rates since the gas film has a very low thermal conductivity. So there has not been much progress in the development of hot air engines. However, since the cost of internal combustion engine fuels is getting excessive, these may find a field of use in the near future.

13.4 Air Standard Cycles

Internal combustion engines (Fig. 13.4) in which the combustion of fuel occurs in the engine cylinder itself are non-cyclic heat engines. The temperature due to the evolution of heat because of the combustion of fuel inside the cylinder is so high that the cylinder is cooled by water circulation around it to avoid rapid deterioration. The working fluid, the fuel-air mixture, undergoes permanent chemical change due to combustion, and the products of combustion after doing work are thrown out of the engine, and a fresh charge is taken. So the working fluid does not undergo a complete thermodynamic cycle.

To simplify the analysis of I.C. engines, *air standard cycles* are conceived. In an air standard cycle, a certain mass of air operates in a complete thermodynamic cycle, where heat is added and rejected with external heat reservoirs, and all the processes in the cycle are reversible. Air is assumed to behave as an ideal gas, and its specific heats are assumed to be constant. These air standard cycles are so conceived that they correspond to the operations of internal combustion engines.

13.5 Otto Cycle (1876)

One very common type of internal combustion engines is the *Spark Ignition (S.I.) engine* used in automobiles. The Otto cycle is the air standard cycle of such an engine. The sequence of processes in the elementary operation of the S.I. engine is given below, with reference to Fig. 13.5(a, b) where the sketches of the engine and the indicator diagram are given.

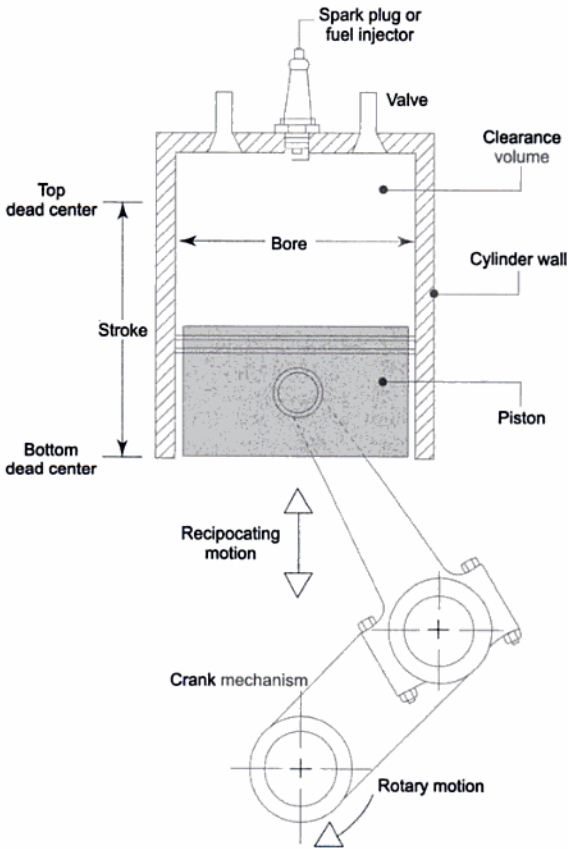

Fig. 13.4 Nomenclature for reciprocating piston-cylinder engines.

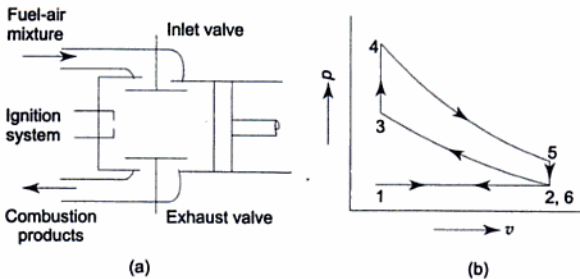

Fig. 13.5 (a) S.I. engine, (b) Indicator diagram

Process 1–2, Intake. The inlet valve is open, the piston moves to the right, admitting fuel-air mixture into the cylinder at constant pressure.

Process 2–3, Compression. Both the valves are closed, the piston compresses the combustible mixture to the minimum volume.

Process 3–4, Combustion. The mixture is then ignited by means of a spark, combustion takes place, and there is an increase in temperature and pressure.

Process 4–5, Expansion. The products of combustion do work on the piston which moves to the right, and the pressure and temperature of the gases decrease.

Process 5–6, Blow-down. The exhaust valve opens, and the pressure drops to the initial pressure.

Process 6–1, Exhaust. With the exhaust valve open, the piston moves inwards to expel the combustion products from the cylinder at constant pressure.

The series of processes as described above constitute a *mechanical cycle*, and not a thermodynamic cycle. The cycle is completed in four strokes of the piston.

Figure 13.5 (c) shows the air standard cycle (Otto cycle) corresponding to the above engine. It consists of:

Two reversible adiabatics and two reversible isochores.

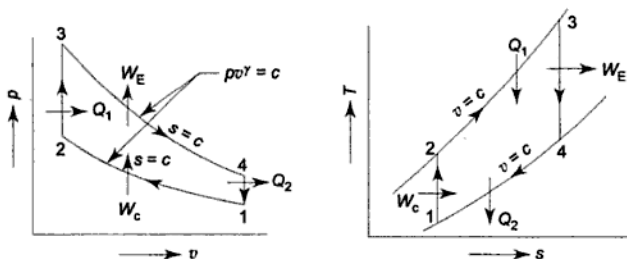

Fig. 13.5 (c) Otto cycle

Air is compressed in process 1–2 reversibly and adiabatically. Heat is then added to air reversibly at constant volume in process 2–3. Work is done by air expanding reversibly and adiabatically in process 3–4. Heat is then rejected by air reversibly at constant volume in process 4–1, and the system (air) comes back to its initial state. Heat transfer processes have been substituted for the combustion and blow-down processes of the engine. The intake and exhaust processes of the engine cancel each other.

Let m be the fixed mass of air undergoing the cycle of operations as described above.

$$\text{Heat supplied } Q_1 = Q_{2-3} = mc_v (T_3 - T_2)$$

$$\text{Heat rejected } Q_2 = Q_{4-1} = mc_v (T_4 - T_1)$$

$$\text{Efficiency } \eta = 1 - \frac{Q_2}{Q_1} = 1 - \frac{mc_v (T_4 - T_1)}{mc_v (T_3 - T_2)}$$

burns spontaneously. The rate of burning can, to some extent, be controlled by the rate of injection of fuel. An engine operating in this way is called a *compression ignition (C.I.) engine*. The sequence of processes in the elementary operation of a C.I. engine, shown in Fig. 13.6, is given below.

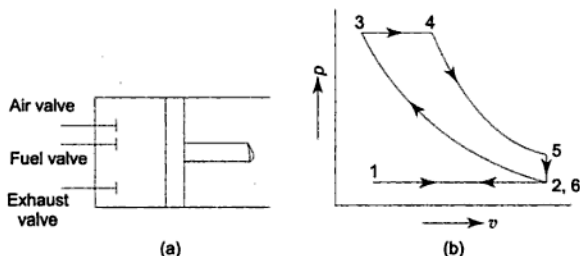

Fig. 13.6 (a) C.I. engine (b) Indicator diagram

Process 1–2, Intake. The air valve is open. The piston moves out admitting air into the cylinder at constant pressure.

Process 2–3, Compression. The air is then compressed by the piston to the minimum volume with all the valves closed.

Process 3–4, Fuel injection and combustion. The fuel valve is open, fuel is sprayed into the hot air, and combustion takes place at constant pressure.

Process 4–5, Expansion. The combustion products expand, doing work on the piston which moves out to the maximum volume.

Process 5–6, Blow-down. The exhaust valve opens, and the pressure drops to the initial pressure.

Process 6–1, Exhaust. With the exhaust valve open, the piston moves towards the cylinder cover driving away the combustion products from the cylinder at constant pressure.

The above processes constitute an engine cycle, which is completed in four strokes of the piston or two revolutions of the crank shaft.

Figure 13.7 shows the air standard cycle, called the *Diesel cycle*, corresponding to the C.I. engine, as described above. The cycle is composed of:

Two reversible adiabatics, one reversible isobar, and one reversible isochore.

Air is compressed reversibly and adiabatically in process 1–2. Heat is then added to it from an external source reversibly at constant pressure in process 2–3. Air then expands reversibly and adiabatically in process 3–4. Heat is rejected reversibly at constant volume in process 4–1, and the cycle repeats itself.

For m kg of air in the cylinder, the efficiency analysis of the cycle can be made as given below.

$$\text{Heat supplied,} \quad Q_1 = Q_{2-3} = mc_p (T_3 - T_2)$$

$$\text{Heat rejected,} \quad Q_2 = Q_{4-1} = mc_v (T_4 - T_1)$$

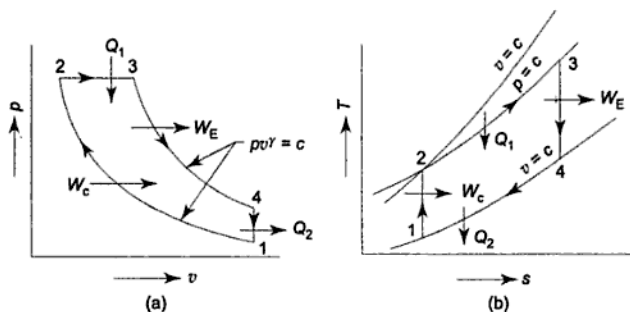

Fig. 13.7 Diesel cycle

$$\text{Efficiency} \quad \eta = 1 - \frac{Q_2}{Q_1} = 1 - \frac{mc_v(T_4 - T_1)}{mc_p(T_3 - T_2)}$$

$$\therefore \quad \eta = 1 - \frac{T_4 - T_1}{\gamma(T_3 - T_2)} \quad (13.6)$$

The efficiency may be expressed in terms of any two of the following three ratios

$$\text{Compression ratio,} \quad r_k = \frac{V_1}{V_2} = \frac{v_1}{v_2}$$

$$\text{Expansion ratio,} \quad r_e = \frac{V_4}{V_3} = \frac{v_4}{v_3}$$

$$\text{Cut-off ratio,} \quad r_c = \frac{V_3}{V_2} = \frac{v_3}{v_2}$$

It is seen that

$$r_k = r_e \cdot r_c$$

Process 3-4

$$\frac{T_4}{T_3} = \left(\frac{v_3}{v_4} \right)^{\gamma-1} = \frac{1}{r_e^{\gamma-1}}$$

$$T_4 = T_3 \frac{r_c^{\gamma-1}}{r_k^{\gamma-1}}$$

Process 2-3

$$\frac{T_2}{T_3} = \frac{p_2 v_2}{p_3 v_3} = \frac{v_2}{v_3} = \frac{1}{r_c}$$

$$\therefore \quad T_2 = T_3 \cdot \frac{1}{r_c}$$

Process 1-2

$$\frac{T_1}{T_2} = \left(\frac{v_2}{v_1} \right)^{\gamma-1} = \frac{1}{r_k^{\gamma-1}}$$

$$\therefore T_1 = T_2 \cdot \frac{1}{r_k^{\gamma-1}} = \frac{T_3}{r_c} \cdot \frac{1}{r_k^{\gamma-1}}$$

Substituting the values of T_1 , T_2 and T_4 in the expression of efficiency (Eq. 13.6)

$$\eta = 1 - \frac{T_3 \cdot \frac{r_c^{\gamma-1}}{r_k^{\gamma-1}} - \frac{T_3}{r_c} \cdot \frac{1}{r_k^{\gamma-1}}}{\gamma \left(T_3 - T_3 \cdot \frac{1}{r_c} \right)}$$

$$\eta_{\text{Diesel}} = 1 - \frac{1}{\gamma} \cdot \frac{1}{r_k^{\gamma-1}} \cdot \frac{r_c^{\gamma} - 1}{r_c - 1} \quad (13.7)$$

As $r_c > 1$, $\frac{1}{\gamma} \left(\frac{r_c^{\gamma} - 1}{r_c - 1} \right)$ is also greater than unity. Therefore, the efficiency of the Diesel cycle is less than that of the Otto cycle for the same compression ratio.

13.7 Limited Pressure Cycle, Mixed Cycle or Dual Cycle

The air standard Diesel cycle does not simulate exactly the pressure-volume variation in an actual compression ignition engine, where the fuel injection is started before the end of compression stroke. A closer approximation is the limited pressure cycle in which some part of heat is added to air at constant volume, and the remainder at constant pressure.

Figure 13.8 shows the $p-v$ and $T-s$ diagrams of the dual cycle. Heat is added reversibly, partly at constant volume (2-3) and partly at constant pressure (3-4).

$$\text{Heat supplied} \quad Q_1 = mc_v(T_3 - T_2) + mc_p(T_4 - T_3)$$

$$\text{Heat rejected} \quad Q_2 = mc_v(T_5 - T_1)$$

$$\text{Efficiency} \quad \eta = 1 - \frac{Q_2}{Q_1}$$

$$= 1 - \frac{mc_v(T_5 - T_1)}{mc_v(T_3 - T_2) + mc_p(T_4 - T_3)}$$

$$= 1 - \frac{T_5 - T_1}{(T_3 - T_2) + \gamma(T_4 - T_3)} \quad (13.8)$$

The efficiency of the cycle can be expressed in terms of the following ratios

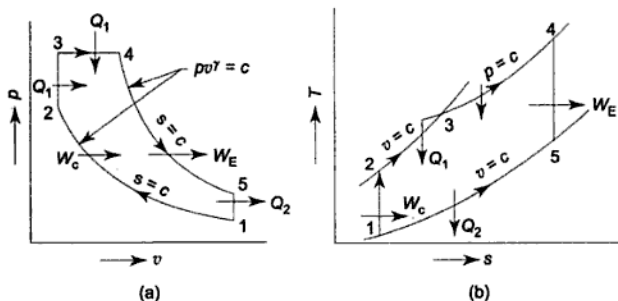

Fig. 13.8 Limited pressure cycle, Mixed cycle or Dual cycle

Compression ratio, $r_k = \frac{V_1}{V_2}$

Expansion ratio, $r_e = \frac{V_5}{V_4}$

Cut-off ratio, $r_c = \frac{V_4}{V_3}$

Constant volume pressure ratio, $r_p = \frac{p_3}{p_2}$

It is seen, as before that

$$r_k = r_c \cdot r_e$$

or $r_e = \frac{r_k}{r_c}$

Process 3-4

$$r_c = \frac{V_4}{V_3} = \frac{T_4 p_3}{p_4 T_3} = \frac{T_4}{T_3}$$

$$T_3 = \frac{T_4}{r_c}$$

Process 2-3

$$\frac{p_2 V_2}{T_2} = \frac{p_3 V_3}{T_3}$$

$$T_2 = T_3 \frac{p_2}{p_3} = \frac{T_4}{r_p \cdot r_c}$$

Process 1-2

$$\frac{T_1}{T_2} = \left(\frac{v_2}{v_1} \right)^{\gamma-1} = \frac{1}{r_k^{\gamma-1}}$$

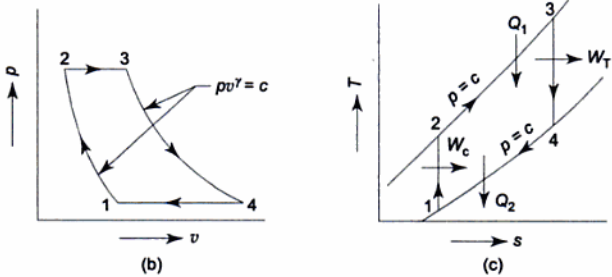
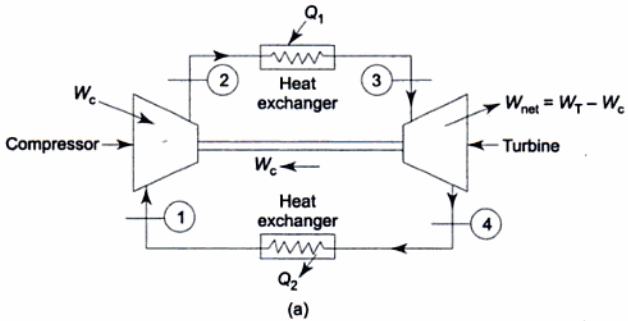

Fig. 13.13 (a-c) Brayton cycle

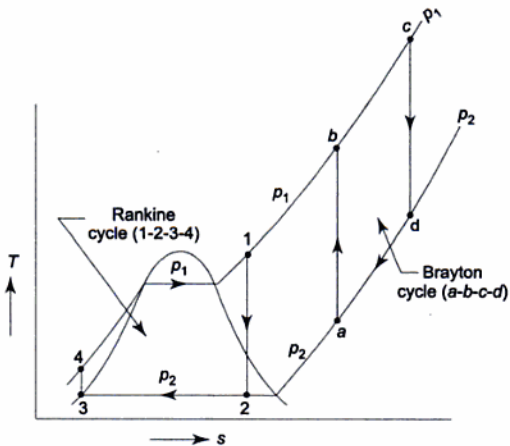

Fig. 13.13 (d) Comparison of Rankine cycle and Brayton cycle, both operating between the same pressures p_1 and p_2

$$\therefore \frac{T_4}{T_1} - 1 = \frac{T_3}{T_2} - 1$$

$$\text{or} \quad \frac{T_4 - T_1}{T_3 - T_2} = \frac{T_1}{T_2} = \left(\frac{p_1}{p_2}\right)^{(\gamma-1)/\gamma} = \left(\frac{v_2}{v_1}\right)^{\gamma-1}$$

If r_k = compression ratio = v_1/v_2 the efficiency becomes (from equation 13.10)

$$\eta = 1 - \left(\frac{v_2}{v_1}\right)^{\gamma-1}$$

$$\text{or} \quad \eta_{\text{Brayton}} = 1 - \frac{1}{r_k^{\gamma-1}} \quad (13.11)$$

$$\text{Work ratio} = \frac{W_T - W_C}{W_T} = \frac{Q_1 - Q_2}{W_T}$$

If r_p = pressure ratio = p_2/p_1 the efficiency may be expressed in the following form also

$$\eta = 1 - \left(\frac{p_1}{p_2}\right)^{(\gamma-1)/\gamma}$$

$$\text{or} \quad \eta_{\text{Brayton}} = 1 - \frac{1}{(r_p)^{(\gamma-1)/\gamma}} \quad (13.12)$$

The efficiency of the Brayton cycle, therefore, depends upon either the compression ratio or the pressure ratio. For the same compression ratio, the Brayton cycle efficiency is equal to the Otto cycle efficiency.

A closed cycle gas turbine plant (Fig. 13.13) is used in a gas-cooled nuclear reactor plant, where the source is a high temperature gas-cooled reactor (HTGR) supplying heat from nuclear fission directly to the working fluid (a gas).

Both Rankine cycle and Brayton cycle consist of two reversible isobars and two reversible adiabatics (Fig. 13.13 (d)). While in Rankine cycle, the working fluid undergoes phase change, in Brayton cycle the working fluid always remains in the gaseous phase. Both the pump and the steam turbine in the case of Rankine cycle, and the compressor and the gas turbine in the case of Brayton cycle operate through the same pressure difference of p_1 and p_2 . All are steady-flow machines

and the work transfer is given by $-\int_{p_1}^{p_2} v dp$. For Brayton cycle, the average

specific volume of air handled by the compressor is less than the same of gas in the gas turbine (since the gas temperature is much higher), the work done by the gas turbine is more than the work input to the compressor, so that there is W_{net} available to deliver. In the case of Rankine cycle, the specific volume of water in the pump is much less than that of the steam expanding in the steam turbine, so $W_T \gg W_p$. Therefore, steam power plants are more popular than the gas turbine plants for electricity generation.

13.9.1 Comparison between Brayton Cycle and Otto Cycle

Brayton and Otto cycles are shown superimposed on the p - v and T - s diagrams in Fig. 13.14. For the same r_k and work capacity, the Brayton cycle (1-2-5-6) handles a larger range of volume and a smaller range of pressure and temperature than does the Otto cycle (1-2-3-4).

In the reciprocating engine field, the Brayton cycle is not suitable. A reciprocating engine cannot efficiently handle a large volume flow of low pressure gas, for which the engine size ($\pi/4D^2L$) becomes large, and the friction losses also become more. So the Otto cycle is more suitable in the reciprocating engine field.

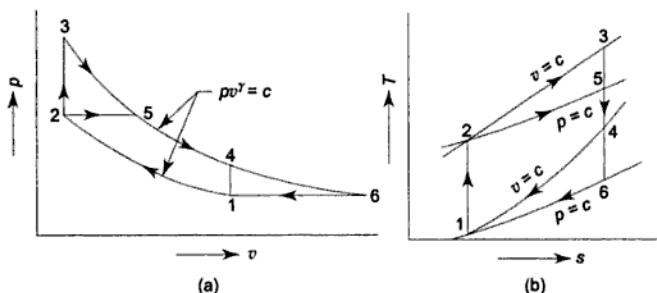

Fig. 13.14 Comparison of Otto and Brayton cycles

In turbine plants, however, the Brayton cycle is more suitable than the Otto cycle. An internal combustion engine is exposed to the highest temperature (after the combustion of fuel) only for a short while, and it gets time to become cool in the other processes of the cycle. On the other hand, a gas turbine plant, a steady flow device, is always exposed to the highest temperature used. So to protect material, the maximum temperature of gas that can be used in a gas turbine plant cannot be as high as in an internal combustion engine. Also, in the steady flow machinery, it is more difficult to carry out heat transfer at constant volume than at constant pressure. Moreover, a gas turbine can handle a large volume flow of gas quite efficiently. So we find that the Brayton cycle is the basic air standard cycle for all modern gas turbine plants.

13.9.2 Effect of Regeneration on Brayton Cycle Efficiency

The efficiency of the Brayton cycle can be increased by utilizing part of the energy of the exhaust gas from the turbine in heating up the air leaving the compressor in a heat exchanger called a *regenerator*, thereby reducing the amount of heat supplied from an external source and also the amount of heat rejected. Such a cycle is illustrated in Fig. 13.15. The temperature of air leaving the turbine at 5 is higher than that of air leaving the compressor at 2. In the regenerator, the temperature of air leaving the compressor is raised by heat

$$Q_2 = h_6 - h_1 = c_p (T_6 - T_1)$$

$$W_T = h_4 - h_5 = c_p (T_4 - T_5)$$

$$W_c = h_2 - h_1 = c_p (T_2 - T_1)$$

$$\eta = 1 - \frac{Q_2}{Q_1} = 1 - \frac{T_6 - T_1}{T_4 - T_3}$$

In practice the regenerator is costly, heavy and bulky, and causes pressure losses which bring about a decrease in cycle efficiency. These factors have to be balanced against the gain in efficiency to decide whether it is worthwhile to use the regenerator.

Above a certain pressure ratio (p_2/p_1) the addition of a regenerator causes a loss in cycle efficiency when compared to the original Brayton cycle. In this situation the compressor discharge temperature (T_2) is higher than the turbine exhaust gas temperature (T_5) (Fig. 13.15). The compressed air will thus be cooled in the regenerator and the exhaust gas will be heated. As a result both the heat supply and heat rejected are increased. However, the compressor and turbine works remain unchanged. So, the cycle efficiency (W_{net}/Q_1) decreases.

Let us now derive an expression for the ideal regenerative cycle when the compressed air is heated to the turbine exhaust temperature in the regenerator so that $T_3 = T_5$ and $T_2 = T_6$ (Fig. 13.15). Therefore,

$$\begin{aligned} \eta &= 1 - \frac{Q_2}{Q_1} = 1 - \frac{T_6 - T_1}{T_4 - T_3} = 1 - \frac{T_1}{T_4} \left[\frac{(T_2/T_1) - 1}{1 - (T_5/T_4)} \right] \\ &= 1 - \frac{T_1}{T_4} \cdot \frac{T_2}{T_1} \left[\frac{1 - (T_1/T_2)}{1 - (T_5/T_4)} \right] \end{aligned}$$

Since

$$\frac{T_2}{T_1} = \left(\frac{p_2}{p_1} \right)^{\gamma-1/\gamma} = \frac{T_4}{T_5}$$

$$\eta = 1 - \frac{T_1}{T_4} r_p^{\gamma-1/\gamma} \quad (13.13)$$

For a fixed ratio of (T_1/T_4), the cycle efficiency drops with increasing pressure ratio.

13.9.3 Effect of Irreversibilities in Turbine and Compressor

The Brayton cycle is highly sensitive to the real machine efficiencies of the turbine and the compressor. Figure 13.16 shows the actual and ideal expansion and compression processes.

Turbine efficiency, $\eta_T = \frac{h_3 - h_4}{h_3 - h_{4s}} = \frac{T_3 - T_4}{T_3 - T_{4s}}$

Compressor efficiency, $\eta_C = \frac{h_{2s} - h_1}{h_2 - h_1} = \frac{T_{2s} - T_1}{T_2 - T_1}$

$$W_{net} = W_T - W_C = (h_3 - h_4) - (h_2 - h_1)$$

$$\therefore ((r_p)_{\max})^{(\gamma-1)/\gamma} = \frac{T_{\max}}{T_{\min}}$$

$$\therefore (r_p)_{\max} = \left(\frac{T_{\max}}{T_{\min}} \right)^{\gamma/(\gamma-1)} \quad (13.14)$$

From Fig. 13.17 it is seen that the work capacity of the cycle, operating between T_{\max} and T_{\min} , is zero when $r_p = 1$ passes through a maximum, and then again becomes zero when the Carnot efficiency is reached. There is an optimum value of pressure ratio $(r_p)_{\text{opt}}$ at which work capacity becomes a maximum, as shown in Fig. 13.19.

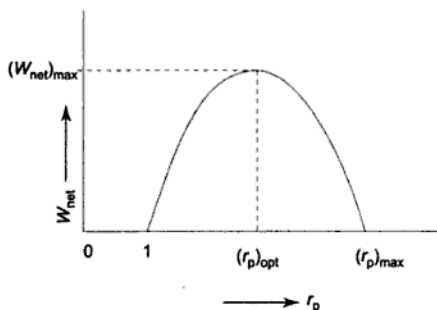

Fig. 13.19 Effect of pressure ratio on net output

For 1 kg,

$$W_{\text{net}} = c_p [(T_3 - T_4) - (T_2 - T_1)]$$

where

$$T_3 = T_{\max} \text{ and } T_1 = T_{\min}$$

Now

$$\frac{T_3}{T_4} = (r_p)^{(\gamma-1)/\gamma}$$

\therefore

$$T_4 = T_3 \cdot r_p^{-(\gamma-1)/\gamma}$$

Similarly

$$T_2 = T_1 \cdot r_p^{(\gamma-1)/\gamma}$$

Substituting in the expression for W_{net}

$$W_{\text{net}} = c_p [T_3 - T_3 \cdot (r_p)^{-(\gamma-1)/\gamma} - T_1 r_p^{(\gamma-1)/\gamma} + T_1] \quad (13.15)$$

To find $(r_p)_{\text{opt}}$

$$\frac{dW_{\text{net}}}{dr_p} = c_p \left[-T_3 \left(-\frac{\gamma-1}{\gamma} \right) r_p^{-(1+(1/\gamma)-1)} - T_1 \left(\frac{\gamma-1}{\gamma} \right) r_p^{(1-(1/\gamma)-1)} \right] = 0$$

$$\therefore T_3 \left(\frac{\gamma-1}{\gamma} \right) r_p^{(1/\gamma)-2} = T_1 \left(\frac{\gamma-1}{\gamma} \right) \cdot r_p^{-1/\gamma}$$

$$\therefore r_p^{-(1/\gamma)-(1/\gamma)+2} = \frac{T_3}{T_1}$$

$$\text{or } (r_p)_{\text{opt}} = \left(\frac{T_3}{T_1} \right)^{\gamma/2(\gamma-1)}$$

$$\therefore (r_p)_{\text{opt}} = \left(\frac{T_{\text{max}}}{T_{\text{min}}} \right)^{\gamma/2(\gamma-1)} \quad (13.16)$$

From Eqs (13.14) and (13.16)

$$(r_p)_{\text{opt}} = \sqrt{(r_p)_{\text{max}}} \quad (13.17)$$

Substituting the values of $(r_p)_{\text{opt}}$ in Eq. (13.15)

$$W_{\text{net}} = (W_{\text{net}})_{\text{max}} = c_p \left[T_3 - T_3 \left(\frac{T_1}{T_3} \right)^{\frac{\gamma}{2(\gamma-1)}} \frac{\gamma}{2(\gamma-1)} \frac{\gamma-1}{\gamma} \right. \\ \left. - T_1 \left(\frac{T_3}{T_1} \right)^{\frac{\gamma}{2(\gamma-1)}} \frac{\gamma}{2(\gamma-1)} \frac{\gamma-1}{\gamma} + T_1 \right] \\ = c_p [T_3 - 2\sqrt{T_1 T_3} + T_1]$$

$$\text{or } (W_{\text{net}})_{\text{max}} = c_p (\sqrt{T_{\text{max}}} - \sqrt{T_{\text{min}}})^2 \quad (13.18)$$

$$\eta_{\text{cycle}} = 1 - \frac{1}{r_p^{\gamma-1/\gamma}} = 1 - \sqrt{\frac{T_{\text{min}}}{T_{\text{max}}}} \quad (13.19)$$

Considering the cycles 1-2'-3'-4' and 1-2''-3''-4'' (Fig. 13.17), it is obvious that to obtain a reasonable work capacity, a certain reduction in efficiency must be accepted.

13.9.5 Effect of Intercooling and Reheating on Brayton Cycle

The efficiency of the Brayton cycle may often be increased by the use of staged compression with intercooling, or by using staged heat supply, called reheat.

Let the compression process be divided into two stages. Air, after being compressed in the first stage, is cooled to the initial temperature in a heat exchanger, called an intercooler, and then compressed further in the second stage (Fig. 13.20). 1-2'-5-6 is the ideal cycle without intercooling, having a single-stage compression, 1-2-3-4-6 is the cycle with intercooling, having a two-stage compression. The cycle 2-3-4-2' is thus added to the basic cycle 1-2'-5-6. There is more work capacity, since the included area is more. There is more heat supply also. For the cycle 4-2'-2-3, T_{m1} is lower and T_{m2} higher (lower r_p) than those of the basic cycle 1-2'-5-6. So the efficiency of the cycle reduces by staging the compression and intercooling. But if a regenerator is used, the low temperature heat addition (4-2') may be obtained by recovering energy from the exhaust gases from the turbine. So there may be a net gain in efficiency when intercooling is adopted in conjunction with a regenerator.

Similarly, let the total heat supply be given in two stages and the expansion process be divided in stages in two turbines (T_1 and T_2) with intermediate reheat, as shown in Fig. 13.21. 1-2-3-4' is the cycle with a single-stage heat supply.

having no reheat, with total expansion in one turbine only. 1-2-3-4-5-6 is the cycle with a single-stage reheat, having the expansion divided into two stages. With the basic cycle, the cycle 4-5-6-4 is added because of reheat. The work capacity increases, but the heat supply also increases.

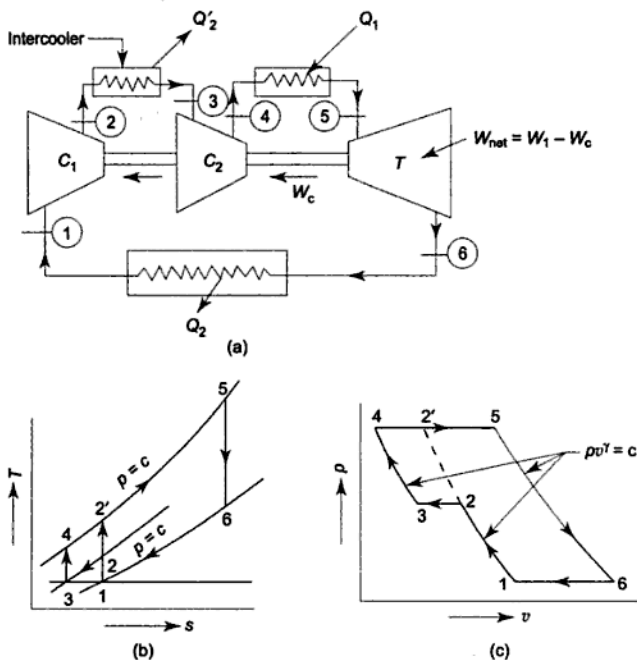

Fig. 13.20 Effect of intercooling on Brayton cycle

In the cycle 4-5-6-4', r_p is lower than in the basic cycle 1-2-3-4', so its efficiency is lower. Therefore, the efficiency of the cycle decreases with the use of reheat. But T_6 is greater than T_4' . Therefore, if regeneration is employed, there is more energy that can be recovered from the turbine exhaust gases. So when regeneration is employed in conjunction with reheat, there may be a net gain in cycle efficiency.

If in one cycle, several stages of intercooling and several stages of reheat are employed, a cycle as shown in Fig. 13.22 is obtained. When the number of such stages is large the cycle reduces to the Ericsson cycle with two reversible isobars and two reversible isotherms. With ideal regeneration the cycle efficiency becomes equal to the Carnot efficiency.

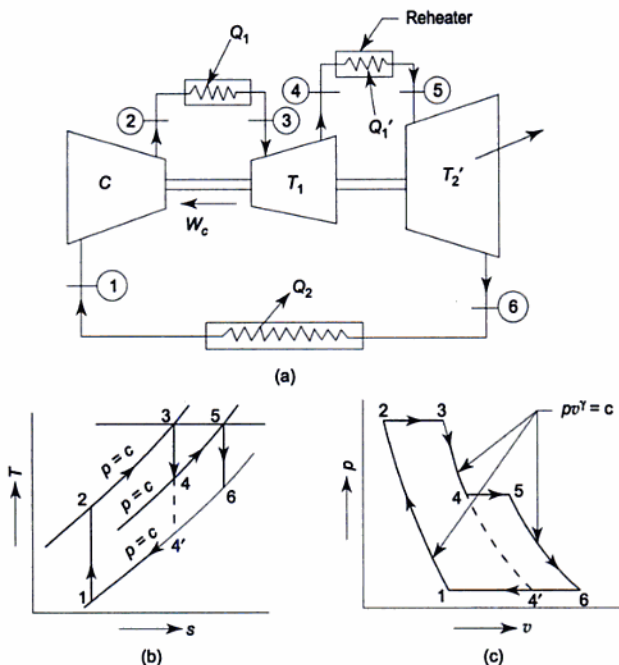

Fig. 13.21 Effect of reheat on Brayton cycle

13.9.6 Ideal Regenerative Cycle with Intercooling and Reheat

Let us consider an ideal regenerative gas turbine cycle with two-stage compression and a single reheat. It assumes that both intercooling and reheating take place at the root mean square of the high and low pressure in the cycle, so that $p_3 = p_2 = p_7 = p_8 = \sqrt{p_1 p_4} = \sqrt{p_6 p_9}$ (Fig. 13.23). Also, the temperature after intercooling is equal to the compressor inlet temperature ($T_1 = T_3$) and the temperature after reheat is equal to the temperature entering the turbine initially ($T_6 = T_8$).

Here,

$$Q_1 = c_p (T_6 - T_5) + c_p (T_8 - T_7)$$

Since $\frac{p_6}{p_7} = \frac{p_8}{p_9}$ and $T_6 = T_8$, it follows that $T_5 = T_7 = T_9$.

\therefore

$$Q_1 = 2 c_p (T_6 - T_7)$$

Again,

$$Q_2 = c_p (T_{10} - T_1) + c_p (T_2 - T_3)$$

but

$$\frac{p_2}{p_1} = \frac{p_4}{p_3} \quad \text{and} \quad T_3 = T_1$$

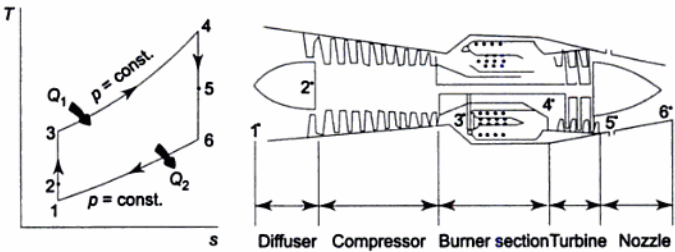

Fig. 13.25 Basic components of a turbojet engine and the T - s diagram of an ideal turbojet cycle

$$\dot{W}_p = F\bar{V}_{\text{aircraft}} = \dot{m}(\bar{V}_{\text{exit}} - \bar{V}_{\text{inlet}}) \bar{V}_{\text{aircraft}} \quad (13.22)$$

The propulsive efficiency, η_p , is defined by:

$$\eta_p = \frac{\text{Propulsive power}}{\text{Energy input rate}} = \frac{\dot{W}_p}{\dot{Q}_{\text{in}}} \quad (13.23)$$

It is a measure of how efficiently the energy released during combustion is converted to propulsive power.

Space and weight limitations prohibit the use of regenerators and intercoolers on aircraft engines. The counterpart of reheating is afterburning. The air-fuel ratio in a jet engine is so high that the turbine exhaust gases are sufficiently rich in oxygen to support the combustion of more fuel in an afterburner (Fig. 13.26). Such burning of fuel raises the temperature of the gas before it expands in the nozzle, increasing the K.E. change in the nozzle and consequently increasing the thrust. In the air-standard case, the combustion is replaced by constant pressure heat addition.

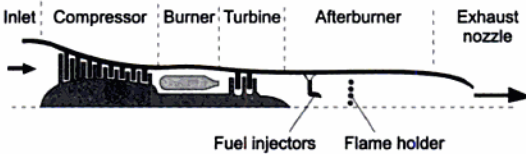

Fig. 13.26 Turbojet engine with afterburner

The most widely used engine in aircraft propulsion is the *turbofan engine* wherein a large fan driven by the turbine forces a considerable amount of air through a duct (cowl) surrounding the engine (Figs 13.27 and 13.28). The fan exhaust leaves the duct at a higher velocity, enhancing the total thrust of the engine significantly. Some of the air entering the engine flows through the compressor, combustion chamber and turbine, and the rest passes through the fan into a duct and is either mixed with the exhaust gases or is discharged separately. It improves the engine performance over a broad operating range. The ratio of the mass flow rates of the two streams is called the *bypass ratio*.

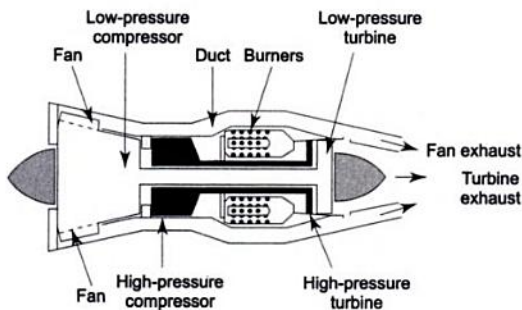

Fig. 13.27 Turbofan engine

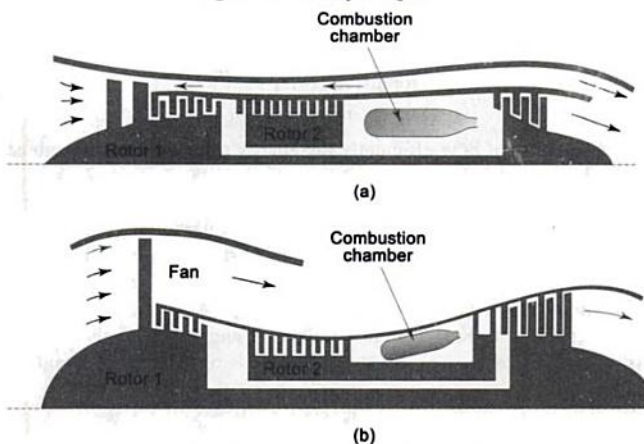

Fig. 13.28 Turbofan or bypass jet engines

$$\text{Bypass ratio} = \frac{\dot{m}_{\text{total}} - \dot{m}_{\text{turbine}}}{\dot{m}_{\text{turbine}}}$$

The bypass ratio can be varied in flight by various means. Turbofan engines deserve most of the credit for the success of jumbo jets, which weigh almost 400,000 kg and are capable of carrying 400 passengers for up to 10,000 km at speeds over 950 km/h with less fuel per passenger mile.

Increasing the bypass ratio of a turbofan engine increases thrust. If the cowl is removed from the fan the result is a *turboprop engine* (Fig. 13.29). Turbofan and turboprop engines differ mainly in their bypass ratio 5 or 6 for turbofans and as high as 100 for turboprop. In general, propellers are more efficient than jet engines, but they are limited to low-speed and low-altitude operation since their efficiency decreases at high speeds and altitudes.

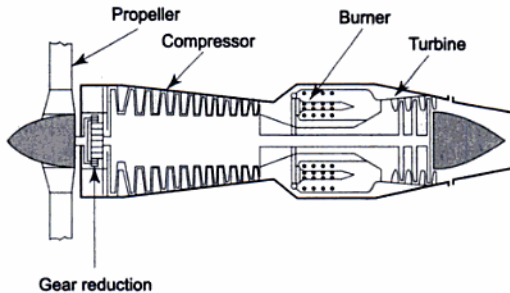

Fig. 13.29 Turboprop engine

A particularly simple type of engine known as a *ramjet* is shown in Fig. 13.30. This engine requires neither a compressor nor a turbine. A sufficient pressure rise is obtained by decelerating the high speed incoming air in the diffuser (ram effect) on being rammed against a barrier. For the ramjet to operate, the aircraft must already be in flight at a sufficiently great speed. The combustion products exiting the combustor are expanded through a nozzle to produce the thrust.

In each of the engines mentioned so far, combustion of the fuel is supported by air brought into the engines from the atmosphere. For very high altitude flight and space travel, where this is no longer possible, rockets may be employed. In a

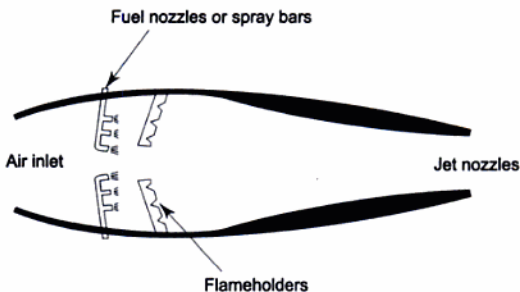

Fig. 13.30 Ramjet engine

rocket, both fuel and an oxidizer (such as liquid oxygen) are carried on board of the craft. High pressure combustion gases are expanded in a nozzle. The gases leave the rocket at very high velocities, producing the thrust to propel the rocket.

13.11 Brayton-Rankine Combined Cycle

Both Rankine cycle and Brayton cycle consist of two reversible isobars and two reversible adiabatics. While the former is a phase change cycle, in the latter the working fluid does not undergo any phase change.

A gas turbine power plant operating on Brayton cycle has certain disadvantages like large compressor work, large exhaust loss, sensitivity to machine inefficiencies (η_T and η_C), relatively lower cycle efficiency and costly fuel. Due to these factors, the cost of power generation by a stationary gas turbine in a utility system is high. However, a gas turbine plant offers certain advantages also, such as less installation cost, less installation time, quick starting and stopping, and fast response to load changes. So, a gas turbine plant is often used as a *peaking unit* for certain hours of the day, when the energy demand is high. To utilize the high temperature exhaust and to raise its plant efficiency a gas turbine may be used in conjunction with a steam turbine plant to offer the gas turbine advantages of quick starting and stopping and permit flexible operation of the combined plant over a wide range of loads.

Let us consider two cyclic power plants coupled in series, the topping plant operating on Brayton cycle and the bottoming one operating on Rankine cycle

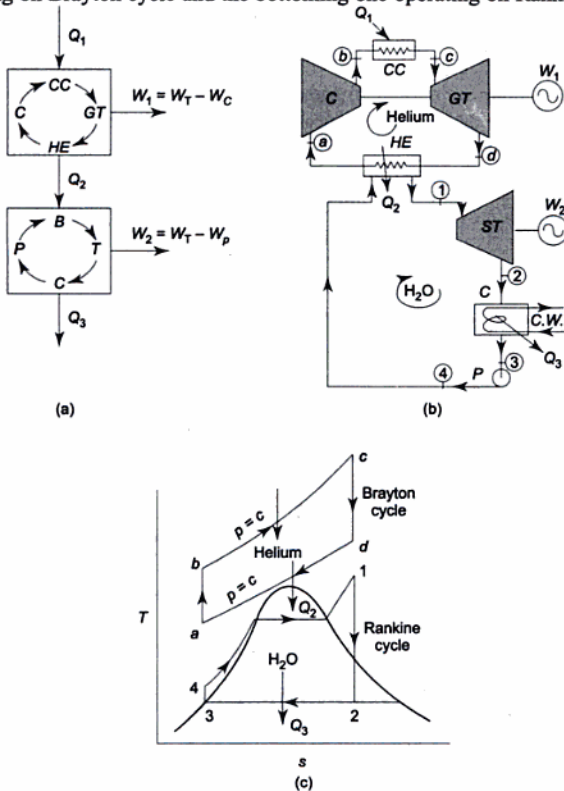

Fig. 13.31 Brayton-Rankine combined cycle plant

neglecting the mass of fuel (for a high air-fuel ratio), and w_a being the mass flow of air.

$$W_{ST} = w_s (h_1 - h_2)$$

where w_s is the steam flow rate. The pump work is neglected. By energy balance,

$$w_a c_{p_g} (T_c - T_f) = w_s (h_1 - h_4)$$

Now,
$$Q_1 = w_a c_{p_g} [(T_c - T_b) + (T_e - T_d)]$$

The overall efficiency of the plant is:

$$\eta = \frac{W_{GT} + W_{ST}}{Q_1}$$

Again,
$$Q_1 = w_f \times C.V.$$

where w_f is the fuel burning rate.

High overall efficiency, low investment cost, less water requirement, large operating flexibility, phased installation, and low environmental impact are some of the advantages of combined gas-steam cycles.

SOLVED EXAMPLES

Example 13.1 An engine working on the Otto cycle is supplied with air at 0.1 MPa, 35°C. The compression ratio is 8. Heat supplied is 2100 kJ/kg. Calculate the maximum pressure and temperature of the cycle, the cycle efficiency, and the mean effective pressure. (For air, $c_p = 1.005$, $c_v = 0.718$, and $R = 0.287$ kJ/kg K).

Solution From Fig. Ex. 13.1

$$T_1 = 273 + 35 = 308 \text{ K}$$

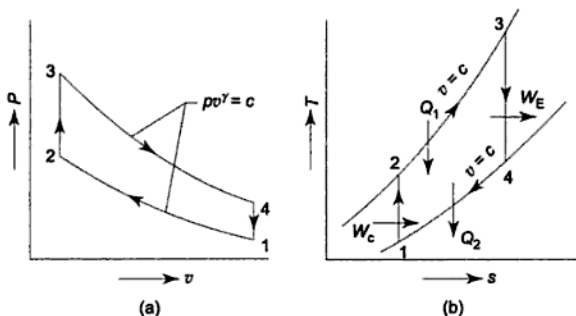

Fig. Ex. 13.1

$$p_1 = 0.1 \text{ MPa} = 100 \text{ kN/m}^2$$

$$Q_1 = 2100 \text{ kJ/kg}$$

$$\therefore \text{Cut-off ratio, } r_c = \frac{v_3}{v_2} = 1.78$$

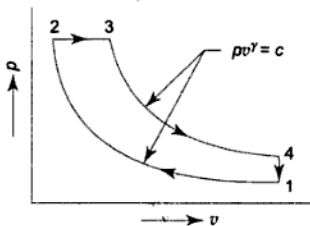

Fig. Ex. 13.2

$$\begin{aligned} \eta_{\text{Diesel}} &= 1 - \frac{1}{\gamma} \cdot \frac{1}{r_k^{\gamma-1}} \cdot \frac{r_c^\gamma - 1}{r_c - 1} \\ &= 1 - \frac{1}{1.4} \cdot \frac{1}{(14)^{0.4}} \cdot \frac{(1.78)^{1.4} - 1}{1.78 - 1} \\ &= 1 - 0.248 \cdot \frac{1.24}{0.78} = 0.605, \text{ i.e., } 60.5\% \quad \text{Ans.} \end{aligned}$$

Example 13.3 In an air standard Diesel cycle, the compression ratio is 16, and at the beginning of isentropic compression, the temperature is 15°C and the pressure is 0.1 MPa. Heat is added until the temperature at the end of the constant pressure process is 1480°C . Calculate (a) the cut-off ratio, (b) the heat supplied per kg of air, (c) the cycle efficiency, and (d) the m.e.p.

Solution From Fig. Ex. 13.3

$$\begin{aligned} r_k &= \frac{v_1}{v_2} = 16 \\ T_1 &= 273 + 15 = 288 \text{ K} \end{aligned}$$

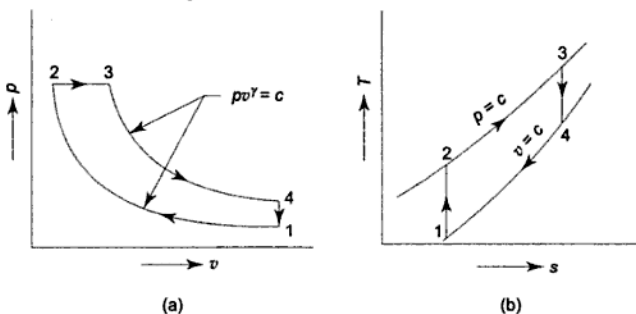

Fig. Ex. 13.3

$$p_1 = 0.1 \text{ MPa} = 100 \text{ kN/m}^2$$

$$T_3 = 1480 + 273 = 1753 \text{ K}$$

$$\frac{T_2}{T_1} = \left(\frac{v_1}{v_2} \right)^{\gamma-1} = (16)^{0.4} = 3.03$$

$$\therefore T_2 = 288 \times 3.03 = 873 \text{ K}$$

$$\frac{p_2 v_2}{T_2} = \frac{p_3 v_3}{T_3}$$

$$(a) \quad \text{Cut-off ratio, } r_c = \frac{v_3}{v_2} = \frac{T_3}{T_2} = \frac{1753}{873} = 2.01 \quad \text{Ans.}$$

$$(b) \text{ Heat supplied, } Q_1 = c_p (T_3 - T_2)$$

$$= 1.005 (1753 - 873)$$

$$= 884.4 \text{ kJ/kg}$$

$$\frac{T_3}{T_4} = \left(\frac{v_4}{v_3} \right)^{\gamma-1} = \left(\frac{v_1}{v_2} \times \frac{v_2}{v_3} \right)^{\gamma-1} = \left(\frac{16}{2.01} \right)^{0.4} = 2.29$$

$$\therefore T_4 = \frac{1753}{2.29} = 766 \text{ K}$$

$$\text{Heat rejected, } Q_2 = c_v (T_4 - T_1) = 0.718 (766 - 288) = 343.2 \text{ kJ/kg}$$

$$(c) \quad \text{Cycle efficiency} = 1 - \frac{Q_2}{Q_1}$$

$$= 1 - \frac{343.2}{884.4} = 0.612 \text{ or } 61.2\% \quad \text{Ans.}$$

It may also be estimated from the equation

$$\eta_{\text{cycle}} = 1 - \frac{1}{\gamma} \cdot \frac{1}{r_c^{\gamma-1}} \cdot \frac{r_c^{\gamma} - 1}{r_c - 1}$$

$$= 1 - \frac{1}{1.4} \cdot \frac{1}{(16)^{0.4}} \cdot \frac{(2.01)^{1.4} - 1}{2.01 - 1}$$

$$= 1 - \frac{1}{1.4} \cdot \frac{1}{3.03} \cdot 1.64 = 0.612 \text{ or } 61.2\% \quad \text{Ans.}$$

$$W_{\text{net}} = Q_1 \times \eta_{\text{cycle}}$$

$$= 884.4 \times 0.612 = 541.3 \text{ kJ/kg}$$

$$v_1 = \frac{RT_1}{p_1} = \frac{0.287 \times 288}{100} = 0.827 \text{ m}^3/\text{kg}$$

$$v_2 = \frac{0.827}{16} = 0.052 \text{ m}^3/\text{kg}$$

$$\therefore v_1 - v_2 = 0.827 - 0.052 = 0.775 \text{ m}^3/\text{kg}$$

$$(d) \quad \text{m.e.p.} = \frac{W_{\text{net}}}{v_1 - v_2} = \frac{541.3}{0.775} = 698.45 \text{ kPa} \quad \text{Ans.}$$

Example 13.4 An air standard dual cycle has a compression ratio of 16, and compression begins at 1 bar, 50°C. The maximum pressure is 70 bar. The heat transferred to air at constant pressure is equal to that at constant volume. Estimate (a) the pressures and temperatures at the cardinal points of the cycle, (b) the cycle efficiency, and (c) the m.e.p. of the cycle, $c_v = 0.718 \text{ kJ/kg K}$, $c_p = 1.005 \text{ kJ/kg K}$.

Solution Given: (Fig. Ex. 13.4)

$$T_1 = 273 + 50 = 323 \text{ K}$$

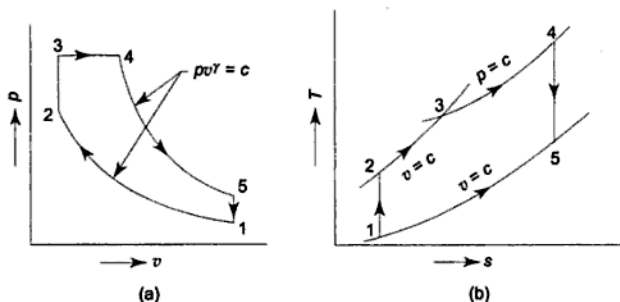

Fig. Ex. 13.4

$$\frac{T_2}{T_1} = \left(\frac{v_1}{v_2} \right)^{\gamma-1} = (16)^{0.4}$$

$$\therefore T_2 = 979 \text{ K}$$

$$p_2 = p_1 \left(\frac{v_1}{v_2} \right)^{\gamma} = 1.0 \times (16)^{1.4} = 48.5 \text{ bar}$$

$$T_3 = T_2 \cdot \frac{p_3}{p_1} = 979 \times \frac{70}{48.5} = 1413 \text{ K}$$

$$Q_{2-3} = c_v (T_3 - T_2) = 0.718 (1413 - 979) = 312 \text{ kJ/kg}$$

Now

$$Q_{2-3} = Q_{3-4} = c_p (T_4 - T_3)$$

$$\therefore T_4 = \frac{312}{1.005} + 1413 = 1723 \text{ K}$$

$$\frac{v_4}{v_3} = \frac{T_4}{T_3} = \frac{1723}{1413} = 1.22$$

$$\therefore \frac{v_5}{v_4} = \frac{v_1}{v_2} \times \frac{v_3}{v_4} = \frac{16}{1.22} = 13.1$$

$$T_3 = 1173 \text{ K}$$

$$r_p = 6, \eta_T = \eta_C = 0.8$$

Without a regenerator

$$\frac{T_{2s}}{T_1} = \left(\frac{p_2}{p_1} \right)^{(\gamma-1)/\gamma} = \frac{T_3}{T_{4s}} = (6)^{0.4/1.4} = 1.668$$

$$T_{2s} = 303 \times 1.668 = 505 \text{ K}$$

$$T_{4s} = \frac{1173}{1.668} = 705 \text{ K}$$

$$T_2 - T_1 = \frac{T_{2s} - T_1}{\eta_C} = \frac{505 - 303}{0.8} = 252 \text{ K}$$

$$T_3 - T_4 = \eta_T (T_3 - T_{4s}) = 0.8 (1173 - 705) = 375 \text{ K}$$

$$W_T = h_3 - h_4 = c_p (T_3 - T_4) = 1.005 \times 375 = 376.88 \text{ kJ/kg}$$

$$W_C = h_2 - h_1 = c_p (T_2 - T_1) = 1.005 \times 252 = 253.26 \text{ kJ/kg}$$

$$T_2 = 252 + 303 = 555 \text{ K}$$

$$Q_1 = h_3 - h_2 = c_p (T_3 - T_2) = 1.005 (1173 - 555) = 621.09 \text{ kJ/kg}$$

$$\therefore \eta = \frac{W_T - W_C}{Q_1} = \frac{376.88 - 253.26}{621.09} = 0.199 \text{ or } 19.9\%$$

With regenerator

$$T_4 = T_3 - 375 = 1173 - 375 = 798 \text{ K}$$

$$\text{Regenerator effectiveness} = \frac{T_6 - T_2}{T_4 - T_2} = 0.75$$

$$\therefore T_6 - 555 = 0.75 (798 - 555)$$

$$\text{or } T_6 = 737.3 \text{ K}$$

$$\begin{aligned} \therefore Q_1 &= h_3 - h_6 = c_p (T_3 - T_6) \\ &= 1.005 (1173 - 737.3) \\ &= 437.88 \text{ kJ/kg} \end{aligned}$$

W_{net} remains the same.

$$\therefore \eta = \frac{W_{\text{net}}}{Q_1} = \frac{123.62}{437.9} = 0.2837 \text{ or } 28.37\%$$

\therefore Percentage increase due to regeneration

$$= \frac{0.2837 - 0.199}{0.199} = 0.4256, \text{ or } 42.56\%$$

Example 13.6 A gas turbine plant operates on the Brayton cycle between $T_{\text{min}} = 300 \text{ K}$ and $T_{\text{max}} = 1073 \text{ K}$. Find the maximum work done per kg of air, and the corresponding cycle efficiency. How does this efficiency compare with the Carnot cycle efficiency operating between the same two temperatures?

$$T_{2s}/T_1 = p_{2s}/p_1^{(\gamma-1)/\gamma} = 8^{0.4/1.4} = 1.181$$

$$T_{2s} = 563.3 \text{ K}$$

$$\frac{T_{2s} - T_1}{T_2 - T_1} = 0.87, T_2 = 601 \text{ K}$$

$$T_3/T_{4s} = (p_3/p_{4s})^{(\gamma-1)/\gamma} = \left(\frac{0.95 p_2}{p_1} \right)^{0.4/1.4} = 1.785$$

$$T_{4s} = 765.83 \text{ K}$$

$$W_C = 290 \dot{m}c_p, W_T = 541.06 \dot{m}c_p \text{ and } Q_1 = 766 \dot{m}c_p$$

$$\eta_{\text{cycle}} = \frac{541.06 - 290}{766} = 0.328$$

Case-2: With cooling

$$\eta_{\text{cycle}} = 0.328 - 0.05 = 0.278$$

Since the extraction of compressed air for turbine cooling does not contribute to turbine work or burner fuel flow, it can be treated as an increment x added to the compressor mass flow.

$$\frac{541.06 - 290(1+x)}{766} = 0.278$$

$$\therefore x = 0.13$$

$$\% \text{ of compressor delivery air flow} = \frac{0.13}{1.13} \times 100 = 11.6\% \quad \text{Ans.}$$

Example 13.9 In a gas turbine plant the ratio of $T_{\text{max}}/T_{\text{min}}$ is fixed. Two arrangements of components are to be investigated: (a) single-stage compression followed by expansion in two turbines of equal pressure ratios with reheat to the maximum cycle temperature, and (b) compression in two compressors of equal pressure ratios, with intercooling to the minimum cycle temperature, followed by single-stage expansion. If η_C and η_T are the compressor and turbine efficiencies, show that the optimum specific output is obtained at the same overall pressure ratio for each arrangement.

If η_C is 0.85 and η_T is 0.9, and $T_{\text{max}}/T_{\text{min}}$ is 3.5, determine the above pressure ratio for optimum specific output and show that with arrangement (a) the optimum output exceeds that of arrangement (b) by about 11%.

Solution (a) With reference to Fig. Ex. 13.9(a)

$$T_1 = T_{\text{min}}, T_3 = T_5 = T_{\text{max}}, \frac{p_2}{p_4} = \frac{p_4}{p_1}$$

$$\therefore p_4 = \sqrt{p_1 p_2}$$

$$\frac{p_{2s}}{p_1} = r, \text{ pressure ratio}$$

$$\therefore p_{2s} = p_2 = r p_1$$

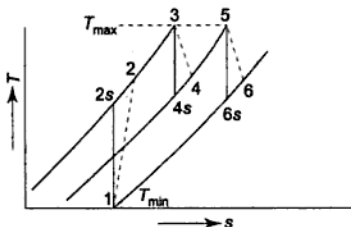
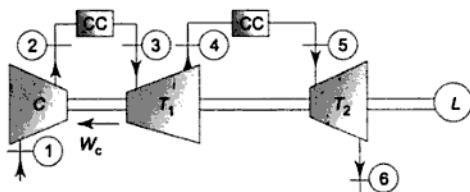

Fig. Ex. 13.9(a)

∴

$$p_4 = \sqrt{r} \cdot p_1$$

$$\frac{T_{2s}}{T_1} = \left(\frac{p_2}{p_1} \right)^{(\gamma-1)/\gamma} = r^x$$

where

$$x = \frac{\gamma - 1}{\gamma}$$

∴

$$T_{2s} = T_{\min} r^x$$

$$(\Delta T_s)_{\text{comp}} = T_{2s} - T_1 = T_{\min} r^x - T_{\min} = T_{\min} (r^x - 1)$$

∴

$$(\Delta T)_{\text{comp}}$$

$$= \frac{T_{\min} (r^x - 1)}{\left(\frac{p_3}{p_4} \right)^{(\gamma-1)/\gamma}} = \left(\frac{r p_1}{\sqrt{r} \cdot p_1} \right)^x = r^{x/2}$$

∴

$$T_{4s} = T_3 r^{-x/2} = T_{\max} r^{-x/2}$$

$$(\Delta T_s)_{\text{turb}} = T_3 - T_{4s} = T_{\max} - T_{\max} \cdot r^{-x/2} \\ = T_{\max} (1 - r^{-x/2})$$

∴

$$(\Delta T)_{\text{turb}1} = \eta_T T_{\max} (1 - r^{-x/2}) = (\Delta T)_{\text{turb}2}$$

∴

$$W_{\text{net}} = c_p \left[2 \eta_T T_{\max} (1 - r^{-x/2}) - \frac{T_{\min}}{\eta_C} (r^x - 1) \right]$$

$$\frac{dW_{\text{net}}}{dr} = c_p \left[2 \eta_T T_{\max} \frac{x}{2} \cdot r^{-x/2-1} - \frac{T_{\min}}{\eta_C} x \cdot r^{x-1} \right] = 0$$

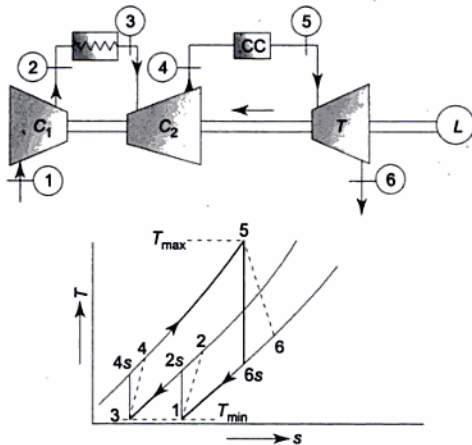

Fig. Ex. 13.9(b)

On simplification

$$r^{3x/2} = \eta_T \eta_C \frac{T_{\max}}{T_{\min}}$$

$$\therefore r_{\text{opt}} = \left(\eta_T \eta_C \frac{T_{\max}}{T_{\min}} \right)^{2\gamma/3(\gamma-1)}$$

(b) With reference to Fig. Ex. 13.9(b)

$$\frac{T_{2s}}{T_{\min}} = \left(\frac{p_2}{p_1} \right)^{(\gamma-1)/\gamma} = (\sqrt{r})^x = r^{x/2}$$

$$(\Delta T_s)_{\text{comp 1}} = T_{2s} - T_1 = T_{\min} (r^{x/2} - 1)$$

$$(\Delta T)_{\text{comp 1}} = \frac{T_{\min} (r^{x/2} - 1)}{\eta_C} = (\Delta T)_{\text{comp 2}}$$

$$\frac{T_{\max}}{T_{6s}} = \left(\frac{p_5}{p_6} \right)^{(\gamma-1)/\gamma} = r^x$$

$$\therefore T_{6s} = T_{\max} \cdot r^{-x}$$

$$(\Delta T_s)_{\text{turb}} = T_{\max} - T_{6s} = T_{\max} (1 - r^{-x})$$

$$(\Delta T)_{\text{turb}} = \eta_T T_{\max} (1 - r^{-x})$$

$$W_{\text{net}} = c_p \left[\eta_T T_{\max} (1 - r^{-x}) - \frac{2 T_{\min} (r^{x/2} - 1)}{\eta_C} \right]$$

$$0 = c_p(T_2 - T_1) - \frac{V_1^2}{2}$$

$$T_2 = T_1 + \frac{V_1^2}{2c_p} = 233 + \frac{300^2}{2 \times 1.005} \times 10^{-3}$$

$$= 277.78 \text{ K}$$

$$p_2 = p_1(T_2/T_1)^{\gamma/(\gamma-1)}$$

$$= 35 \frac{\text{kN}}{\text{m}^2} \left(\frac{277.78}{233} \right)^{1.4/0.4} = 64.76 \text{ kPa}$$

$$p_3 = r_p p_2 = 10 \times 64.76 = 647.6 \text{ kPa}$$

$$T_3 = \left(\frac{p_3}{p_2} \right)^{(\gamma-1)/\gamma} T_2 = 277.78(10)^{0.4/1.4}$$

$$= 536.66 \text{ K}$$

$$W_C = W_T$$

$$h_3 - h_2 = h_4 - h_5$$

$$T_3 - T_2 = T_4 - T_5$$

$$T_5 = T_4 - T_3 + T_2 = 1373 - 536.66 + 277.78$$

$$= 1114.12 \text{ K}$$

$$p_5 = \left(\frac{T_5}{T_4} \right)^{\gamma/(\gamma-1)} p_4 = 647.6 \left(\frac{1114.12}{1373} \right)^{3.5}$$

$$= 311.69 \text{ K}$$

Ans. (a)

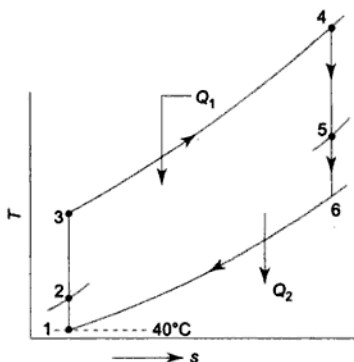

Fig. Ex. 13.10

(b) For isentropic expansion of gases in the nozzle,

$$T_6 = T_5 \left(\frac{p_6}{p_5} \right)^{(\gamma-1)/\gamma} = 1114.12 \left(\frac{35}{311.69} \right)^{0.286}$$

$$h_1 = 3775, h_2 = 2183, h_3 = 138 = h_4, \text{ all in kJ/kg}$$

$$(Q_1)_{St} = h_1 - h_3 = 3775 - 138 = 3637 \text{ kJ/kg}$$

$$Q'_{fe} = 1.11(800 - 100) = 777 \text{ kJ/kg}$$

By energy balance of the steam generator,

$$w_a \times 777 = w_s \times 3637$$

$$w_a/w_s = 4.68$$

$$W_{ST} = h_1 - h_2 = 3775 - 2183 = 1592 \text{ kJ/kg}$$

$$w_a \times 249 + w_s \times 1592 = 190 \times 10^3 \text{ kW}$$

$$w_s (4.68 \times 249 + 1592) = w_s \times 2.757 \times 10^3 = 190 \times 10^3$$

$$w_s = 68.9 \text{ kg/s and } w_a = 322.5 \text{ kg/s}$$

Now, $w_a (612 + 483) = w_f \times 43,300$

$$w_a/w_f = A/F \text{ ratio} = \frac{43,300}{1095} = 39.5 \quad \text{Ans.}$$

$$\text{Fuel energy input} = \frac{322.5}{39.5} \times 43,300 = 353525 \text{ kW}$$

$$= 353.5 \text{ MW}$$

$$\eta_{0A} = \frac{190}{353.5} = 0.537 \text{ or } 53.7\% \quad \text{Ans.}$$

REVIEW QUESTIONS

- 13.1 What are cyclic and non-cyclic heat engines? Give examples.
- 13.2 What are the four processes which constitute the Stirling cycle? Show that the regenerative Stirling cycle has the same efficiency as the Carnot cycle.
- 13.3 State the four processes that constitute the Ericsson cycle. Show that the regenerative Ericsson cycle has the same efficiency as the Carnot cycle.
- 13.4 Mention the merits and demerits of the Stirling and Ericsson cycles.
- 13.5 What is an air standard cycle? Why are such cycles conceived?
- 13.6 What is a spark ignition engine? What is the air standard cycle of such an engine? What are its four processes?
- 13.7 Show that the efficiency of the Otto cycle depends only on the compression ratio.
- 13.8 How is the compression ratio of an SI engine fixed?
- 13.9 What is a compression ignition engine? Why is the compression ratio of such an engine more than that of an SI engine?
- 13.10 State the four processes of the Diesel cycle.
- 13.11 Explain the mixed or dual cycle.
- 13.12 For the same compression ratio and heat rejection, which cycle is most efficient: Otto, Diesel or Dual? Explain with $p-v$ and $T-s$ diagrams.
- 13.13 With the help of $p-v$ and $T-s$ diagrams, show that for the same maximum pressure and temperature of the cycle and the same heat rejection,

$$\eta_{Diesel} > \eta_{Dual} > \eta_{Otto}$$
- 13.14 What are the three basic components of a gas turbine plant? What is the air standard cycle of such a plant? What are the processes it consists of?

- 13.15 Show that the efficiency of the Brayton cycle depends only on the pressure ratio.
- 13.16 What is the application of the closed cycle gas turbine plant?
- 13.17 Discuss the merits and demerits of Brayton and Otto cycles applied to reciprocating and rotating plants.
- 13.18 What is the effect of regeneration on Brayton cycle efficiency? Define the effectiveness of a regenerator.
- 13.19 What is the effect of irreversibilities in turbine and compressor on Brayton cycle efficiency?
- 13.20 Explain the effect of pressure ratio on the net output and efficiency of a Brayton cycle.
- 13.21 Derive the expression of optimum pressure ratio for maximum net work output in an ideal Brayton cycle. What is the corresponding cycle efficiency.
- 13.22 Explain the effects of: (a) intercooling, and (b) reheating, on Brayton cycle.
- 13.23 What is a free shaft turbine?
- 13.24 With the help of flow and $T-s$ diagrams explain the air standard cycle for a jet propulsion plant.
- 13.25 With the help of a neat sketch explain the operation of a turbojet engine. How is the thrust developed in this engine? Why does a commercial airplane fly at high altitudes?
- 13.26 Define propulsive power and propulsive efficiency.
- 13.27 Why are regenerators and intercoolers not used in aircraft engines? What is after-burning? Why is it used?
- 13.28 Explain the working of a turbofan engine with the help of a neat sketch. Define "bypass ratio". How does it influence the engine thrust?
- 13.29 How does a turboprop engine differ from a turbofan engine?
- 13.30 What is a ramjet? How is the thrust produced here?
- 13.31 What is a rocket? How is it propelled?
- 13.32 Explain the advantages and disadvantages of a gas turbine plant for a utility system.
- 13.33 What are the advantages of a combined gas turbine-steam turbine power plant?
- 13.34 With the help of flow and $T-s$ diagrams explain the operation of a combined GT-ST plant. Why is supplementary firing often used?

PROBLEMS

- 13.1 In a Stirling cycle the volume varies between 0.03 and 0.06 m³, the maximum pressure is 0.2 MPa, and the temperature varies between 540°C and 270°C. The working fluid is air (an ideal gas). (a) Find the efficiency and the work done per cycle for the simple cycle. (b) Find the efficiency and the work done per cycle for the cycle with an ideal regenerator, and compare with the Carnot cycle having the same isothermal heat supply process and the same temperature range.
- Ans.* (a) 27.7%, 53.7 kJ/kg, (b) 33.2%
- 13.2 An Ericsson cycle operating with an ideal regenerator works between 1100 K and 288 K. The pressure at the beginning of isothermal compression is 1.013 bar. Determine (a) the compressor and turbine work per kg of air, and (b) the cycle efficiency.

Ans. (a) $W_T = 465$ kJ/kg, $W_C = 121.8$ kJ/kg (b) 0.738

- 13.3 Plot the efficiency of the air standard Otto cycle as a function of the compression ratio for compression ratios from 4 to 16.
- 13.4 Find the air standard efficiencies for Otto cycles with a compression ratio of 6 using ideal gases having specific heat ratios 1.3, 1.4 and 1.67. What are the advantages and disadvantages of using helium as the working fluid?
- 13.5 An engine equipped with a cylinder having a bore of 15 cm and a stroke of 45 cm operates on an Otto cycle. If the clearance volume is 2000 cm^3 , compute the air standard efficiency.
- Ans.* 47.4%
- 13.6 In an air standard Otto cycle the compression ratio is 7, and compression begins at 35°C , 0.1 MPa. The maximum temperature of the cycle is 1100°C . Find (a) the temperature and pressure at the cardinal points of the cycle, (b) the heat supplied per kg of air, (c) the work done per kg of air, (d) the cycle efficiency, and (e) the m.e.p. of the cycle.
- 13.7 An engine working on the Otto cycle has an air standard cycle efficiency of 56% and rejects 544 kJ/kg of air. The pressure and temperature of air at the beginning of compression are 0.1 MPa and 60°C respectively. Compute (a) the compression ratio of the engine, (b) the work done per kg of air, (c) the pressure and temperature at the end of compression, and (d) the maximum pressure in the cycle.
- 13.8 For an air standard Diesel cycle with a compression ratio of 15 plot the efficiency as a function of the cut-off ratio for cut-off ratios from 1 to 4. Compare with the results of Problem 13.3.
- 13.9 In an air standard Diesel cycle, the compression ratio is 15. Compression begins at 0.1 MPa, 40°C . The heat added is 1.675 MJ/kg . Find (a) the maximum temperature of the cycle, (b) the work done per kg of air, (c) the cycle efficiency, (d) the temperature at the end of the isentropic expansion, (e) the cut-off ratio, (f) the maximum pressure of the cycle, and (g) the m.e.p. of the cycle.
- 13.10 Two engines are to operate on Otto and Diesel cycles with the following data: Maximum temperature 1400 K , exhaust temperature 700 K . State of air at the beginning of compression 0.1 MPa, 300 K . Estimate the compression ratios, the maximum pressures, efficiencies, and rate of work outputs (for 1 kg/min of air) of the respective cycles.
- Ans.* Otto— $r_k = 5.656$, $p_{\max} = 2.64 \text{ MPa}$, $W = 2872 \text{ kJ/kg}$, $\eta = 50\%$
 Diesel— $r_k = 7.456$, $p_{\max} = 1.665 \text{ MPa}$, $W = 446.45 \text{ kJ/kg}$, $\eta = 60.8\%$
- 13.11 An air standard limited pressure cycle has a compression ratio of 15 and compression begins at 0.1 MPa, 40°C . The maximum pressure is limited to 6 MPa and the heat added is 1.675 MJ/kg . Compute (a) the heat supplied at constant volume per kg of air, (b) the heat supplied at constant pressure per kg of air, (c) the work done per kg of air, (d) the cycle efficiency, (e) the temperature at the end of the constant volume heating process, (f) the cut-off ratio, and (g) the m.e.p. of the cycle.
- Ans.* (a) 235 kJ/kg , (b) 1440 kJ/kg , (c) 1014 kJ/kg , (d) 60.5%,
 (e) 1252 K , (f) 2.144 (g) 1.21 MPa
- 13.12 In an ideal cycle for an internal combustion engine the pressure and temperature at the beginning of adiabatic compression are respectively 0.11 MPa and 115°C , the compression ratio being 16. At the end of compression heat is added to the working fluid, first, at constant volume, and then at constant pressure reversibly.

The working fluid is then expanded adiabatically and reversibly to the original volume.

If the working fluid is air and the maximum pressure and temperature are respectively 6 MPa and 2000°C, determine, per kg of air (a) the pressure, temperature, volume, and entropy of the air at the five cardinal points of the cycle (take s_1 as the entropy of air at the beginning of compression), and (b) the work output and efficiency of the cycle.

- 13.13 Show that the air standard efficiency for a cycle comprising two constant pressure processes and two isothermal processes (all reversible) is given by

$$\eta = \frac{(T_1 - T_2) \ln (r_p)^{(\gamma-1)/\gamma}}{T_1 [1 + \ln (r_p)^{(\gamma-1)/\gamma} - T_2]}$$

where T_1 and T_2 are the maximum and minimum temperatures of the cycle, and r_p is the pressure ratio.

- 13.14 Obtain an expression for the specific work done by an engine working on the Otto cycle in terms of the maximum and minimum temperatures of the cycle, the compression ratio r_k , and constants of the working fluid (assumed to be an ideal gas).

Hence show that the compression ratio for maximum specific work output is given by

$$r_k = \left(\frac{T_{\min}}{T_{\max}} \right)^{1/2(1-\gamma)}$$

- 13.15 A dual combustion cycle operates with a volumetric compression ratio $r_k = 12$, and with a cut-off ratio 1.615. The maximum pressure is given by $p_{\max} = 54p_1$, where p_1 is the pressure before compression. Assuming indices of compression and expansion of 1.35, show that the m.e.p. of the cycle

$$p_m = 10 p_1$$

Hence evaluate (c) temperatures at cardinal points with $T_1 = 335$ K, and (b) cycle efficiency.

$$\text{Ans. (a) } T_2 = 805 \text{ K, } p_2 = 29.2 p_1, T_3 = 1490 \text{ K, } T_4 = 2410 \text{ K, } T_5 = 1200 \text{ K, (b) } \eta = 0.67$$

- 13.16 Recalculate (a) the temperatures at the cardinal points, (b) the m.e.p., and (c) the cycle efficiency when the cycle of Problem 13.15 is a Diesel cycle with the same compression ratio and a cut-off ratio such as to give an expansion curve coincident with the lower part of that of the dual cycle of Problem 13.15.

$$\text{Ans. (a) } T_2 = 805 \text{ K, } T_3 = 1970 \text{ K, } T_4 = 1142 \text{ K (b) } 6.82 p_1, \text{ (c) } \eta = 0.513$$

- 13.17 In an air standard Brayton cycle the compression ratio is 7 and the maximum temperature of the cycle is 800°C. The compression begins at 0.1 MPa, 35°C. Compare the maximum specific volume and the maximum pressure with the Otto cycle of Problem 13.6. Find (a) the heat supplied per kg of air, (b) the net work done per kg of air, (c) the cycle efficiency, and (d) the temperature at the end of the expansion process.

- 13.18 A gas turbine plant operates on the Brayton cycle between the temperatures 27°C and 800°C. (a) Find the pressure ratio at which the cycle efficiency approaches the Carnot cycle efficiency, (b) find the pressure ratio at which the work done per kg of air is maximum, and (c) compare the efficiency at this pressure ratio with the Carnot efficiency for the given temperatures.

all processes are ideal. Determine (a) pressure p_5 , (b) the net work per kg and mass flow rate, (c) temperature T_3 and cycle thermal efficiency, and (d) the T - s diagram for the cycle.

- 13.31 Repeat Problem 13.30 assuming that the compressor has an efficiency of 80%, both the turbines have efficiencies of 85%, and the regenerator has an efficiency of 72%.
- 13.32 An ideal air cycle consists of isentropic compression, constant volume heat transfer, isothermal expansion to the original pressure, and constant pressure heat transfer to the original temperature. Deduce an expression for the cycle efficiency in terms of volumetric compression ratio r_k , and isothermal expansion ratio, r_e . In such a cycle, the pressure and temperature at the start of compression are 1 bar and 40°C , the compression ratio is 8, and the maximum pressure is 100 bar. Determine the cycle efficiency and the m.e.p.

Ans. 51.5%, 3.45 bar

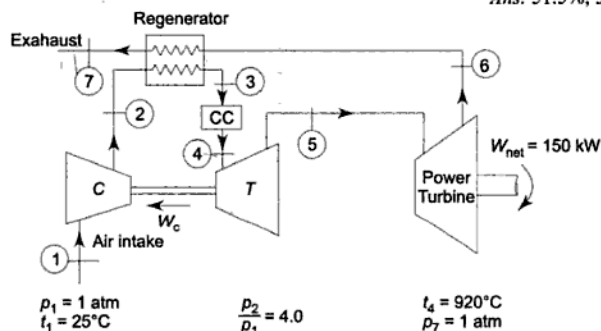

Fig. P 13.30

- 13.33 For a gas turbine jet propulsion unit, shown in Fig. 13.24, the pressure and temperature entering the compressor are 1 atm and 15°C respectively. The pressure ratio across the compressor is 6 to 1 and the temperature at the turbine inlet is 1000°C . On leaving the turbine the air enters the nozzle and expands to 1 atm. Determine the pressure at the nozzle inlet and the velocity of the air leaving the nozzle.
- 13.34 Repeat Problem 13.33, assuming that the efficiency of the compressor and turbine are both 85%, and that the nozzle efficiency is 95%.
- 13.35 Develop expressions for work output per kg and the efficiency of an ideal Brayton cycle with regeneration, assuming maximum possible regeneration. For fixed maximum and minimum temperatures, how do the efficiency and work outputs vary with the pressure ratio? What is the optimum pressure ratio?
- 13.36 For an air standard Otto cycle with fixed intake and maximum temperatures, T_1 and T_3 , find the compression ratio that renders the net work per cycle a maximum. Derive the expression for cycle efficiency at this compression ratio. If the air intake temperature, T_1 , is 300 K and the maximum cycle temperature, T_3 , is 1200 K, compute the compression ratio for maximum net work, maximum work output per kg in a cycle, and the corresponding cycle efficiency.

- 13.47 A regenerative gas turbine with intercooling and reheat operates at steady state. Air enters the compressor at 100 kPa, 300 K with a mass flow rate of 5.807 kg/s. The pressure ratio across the two-stage compressor as well as the turbine is 10. The intercooler and reheater each operate at 300 kPa. At the inlets to the turbine stages, the temperature is 1400 K. The temperature at inlet to the second compressor stage is 300 K. The efficiency of each compressor and turbine stage is 80%. The regenerator effectiveness is 80%. Determine (a) the thermal efficiency, (b) the back work ratio, W_C/W_T , (c) the net power developed.

Ans. (a) 0.443, (b) 0.454, (c) 2046 kW

- 13.48 In a regenerative gas turbine power plant air enters the compressor at 1 bar, 27°C and is compressed to 4 bar. The isentropic efficiency of the compressor is 80% and the regenerator effectiveness is 90%. All of the power developed by the h.p. turbine is used to drive the compressor and the l.p. turbine provides the net power output of 97 kW. Each turbine has an isentropic efficiency of 87% and the temperature at inlet to the h.p. turbine is 1200 K. Determine (a) the mass flow rate of air into the compressor, (b) the thermal efficiency, (c) the temperature of the air at the exit of the regenerator.

Ans. (a) 0.562 kg/s, (b) 0.432, (c) 523.2 K

14

Refrigeration Cycles

14.1 Refrigeration by Non-Cyclic Processes

Refrigeration is the cooling of a system below the temperature of its surroundings.

The melting of ice or snow was one of the earliest methods of refrigeration and is still employed. Ice melts at 0°C . So when ice is placed in a given space warmer than 0°C , heat flows into the ice and the space is cooled or refrigerated. The latent heat of fusion of ice is supplied from the surroundings, and the ice changes its state from solid to liquid.

Another medium of refrigeration is solid carbon dioxide or dry ice. At atmospheric pressure CO_2 cannot exist in a liquid state, and consequently, when solid CO_2 is exposed to atmosphere, it sublimates, i.e., it goes directly from solid to vapour, by absorbing the latent heat of sublimation (620 kJ/kg at 1 atm , -78.5°C) from the surroundings (Fig. 14.1). Thus dry ice is suitable for low temperature refrigeration.

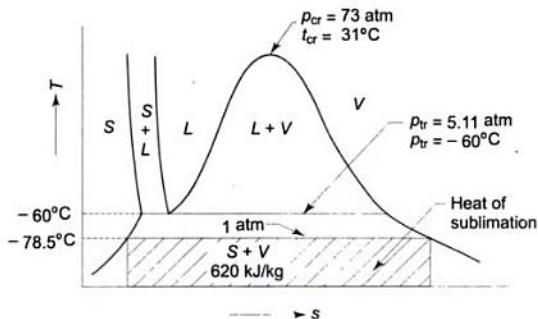

Fig. 14.1 T - s diagram of CO_2

In these two examples it is observed that the refrigeration effect has been accomplished by non-cyclic processes. Of greater importance, however, are the methods in which the cooling substance is not consumed and discarded, but used again and again in a thermodynamic cycle.

14.2 Reversed Heat Engine Cycle

A reversed heat engine cycle, as explained in Sec. 6.12, is visualized as an engine operating in the reverse way, i.e., receiving heat from a low temperature region, discharging heat to a high temperature region, and receiving a net inflow of work (Fig. 14.2). Under such conditions the cycle is called a *heat pump cycle* or a *refrigeration cycle* (see Sec. 6.6). For a heat pump

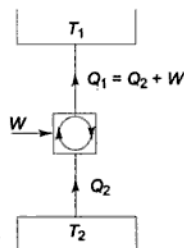

Fig. 14.2 Reversed heat engine cycle

$$(\text{COP})_{\text{H.P.}} = \frac{Q_1}{W} = \frac{Q_1}{Q_1 - Q_2}$$

and for a refrigerator

$$(\text{COP})_{\text{ref}} = \frac{Q_2}{W} = \frac{Q_2}{Q_1 - Q_2}$$

The working fluid in a refrigeration cycle is called a *refrigerant*. In the reversed Carnot cycle (Fig. 14.3), the refrigerant is first compressed reversibly and adiabatically in process 1–2 where the work input per kg of refrigerant is W_c , then it is condensed reversibly in process 2–3 where the heat rejection is Q_1 , the refrigerant then expands reversibly and adiabatically in process 3–4 where the work output is W_e , and finally it absorbs heat Q_2 reversibly by evaporation from the surroundings in process 4–1.

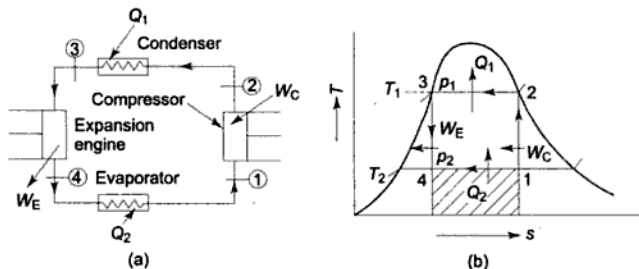

Fig. 14.3 Reversed Carnot cycle

Here

$$Q_1 = T_1 (s_2 - s_3), \quad Q_2 = T_2 (s_1 - s_4)$$

and

$$W_{\text{net}} = W_C - W_E = Q_1 - Q_2 = (T_1 - T_2) (s_1 - s_4)$$

where T_1 is the temperature of heat rejection and T_2 the temperature of heat absorption.

$$(\text{COP}_{\text{ref}})_{\text{rev}} = \frac{Q_2}{W_{\text{net}}} = \frac{T_2}{T_1 - T_2}$$

and

$$(\text{COP}_{\text{H.P.}})_{\text{rev}} = \frac{Q_1}{W_{\text{net}}} = \frac{T_1}{T_1 - T_2} \quad (14.1)$$

As shown in Sec. 6.16, these are the maximum values for any refrigerator or heat pump operating between T_1 and T_2 . It is important to note that for the same T_2 or T_1 , the COP increases with the decrease in the temperature difference ($T_1 - T_2$), i.e., the closer the temperatures T_1 and T_2 , the higher the COP.

14.3 Vapour Compression Refrigeration Cycle

In an actual vapour refrigeration cycle, an expansion engine, as shown in Fig. 14.3, is not used, since power recovery is small and does not justify the cost of the engine. A throttling valve or a capillary tube is used for expansion in reducing the pressure from p_1 to p_2 . The basic operations involved in a vapour compression refrigeration plant are illustrated in the flow diagram, Fig. 14.4, and the property diagrams, Fig. 14.5.

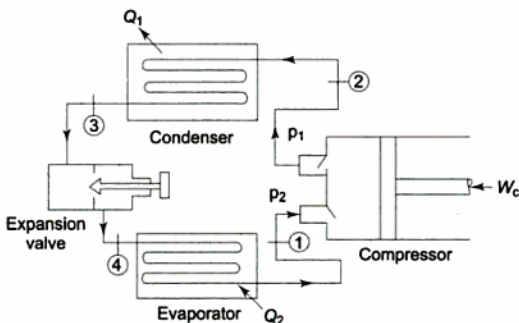

Fig. 14.4 Vapour compression refrigeration plant-flow diagram

The operations represented are as follows for an idealized plant:

1. Compression A reversible adiabatic process 1-2 or 1'-2' either starting with saturated vapour (state 1), called *dry compression*, or starting with wet vapour (state 1'), called *wet compression*. Dry compression (1-2) is always preferred to wet compression (1'-2'), because with wet compression there is a danger of the liquid refrigerant being trapped in the head of the cylinder by the rising piston

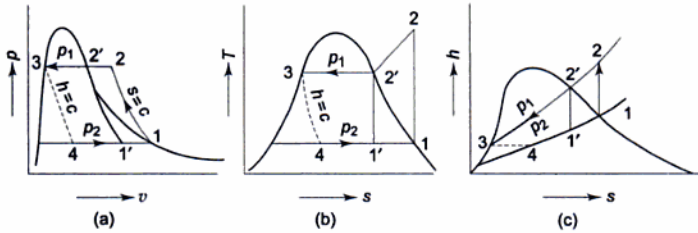

Fig. 14.5 Vapour compression refrigeration cycle-property diagrams

which may damage the valves or the cylinder head, and the droplets of liquid refrigerant may wash away the lubricating oil from the walls of the cylinder, thus accelerating wear.

2. Cooling and Condensing A reversible constant pressure process, 2-3, first desuperheated and then condensed, ending with saturated liquid. Heat Q_1 is transferred out.

3. Expansion An adiabatic throttling process 3-4, for which enthalpy remains unchanged. States 3 and 4 are equilibrium points. Process 3-4 is adiabatic (then only $h_3 = h_4$ by S.F.E.E.), but not isentropic.

$$Tds = dh - vdp, \text{ or } s_4 - s_3 = - \int_{p_1}^{p_2} \frac{vdp}{T}$$

Hence it is irreversible and cannot be shown in property diagrams. States 3 and 4 have simply been joined by a dotted line.

4. Evaporation A constant pressure reversible process, 4-1, which completes the cycle. The refrigerant is throttled by the expansion valve to a pressure, the saturation temperature at this pressure being below the temperature of the surroundings. Heat then flows, by virtue of temperature difference, from the surroundings, which gets cooled or refrigerated, to the refrigerant, which then evaporates, absorbing the heat of evaporation. The evaporator thus produces the cooling or the *refrigerating effect*, absorbing heat Q_2 from the surroundings by evaporation.

In refrigeration practice, enthalpy is the most sought-after property. The diagram in $p-h$ coordinates is found to be the most convenient. The constant property lines in the $p-h$ diagram are shown in Fig. 14.6, and the vapour compression cycle in Fig. 14.7.

14.3.1 Performance and Capacity of a Vapour Compression Plant

Figure 14.8 shows the simplified diagram of a vapour compression refrigeration plant.

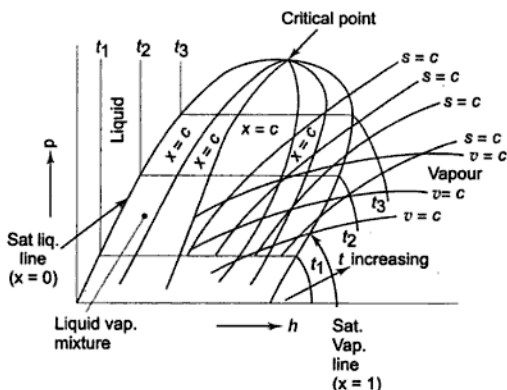

Fig. 14.6 Phase diagram with constant property lines on p - h plot

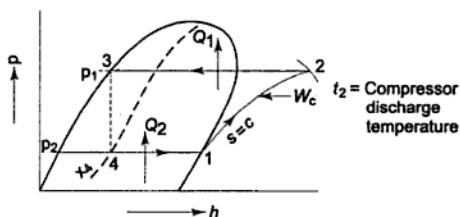

Fig. 14.7 Vapour compression cycle on p - h diagram

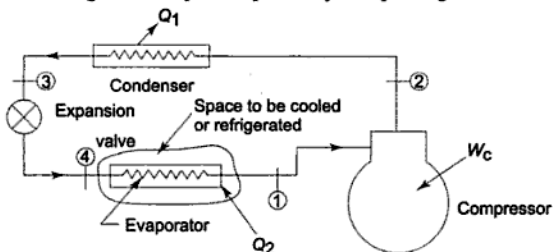

Fig. 14.8 Vapour compression plant

When steady state has been reached, for 1 kg flow of refrigerant through the cycle, the steady flow energy equations (neglecting K.E. and P.E. changes) may be written for each of the components in the cycle as given below.

Compressor

$$h_1 + W_c = h_2$$

\therefore

$$W_c = (h_2 - h_1) \text{ kJ/kg}$$

$$W_c = w(h_2 - h_1) \text{ kJ/s}$$

14.3.2 Actual Vapour Compression Cycle

In order to ascertain that there is no droplet of liquid refrigerant being carried over into the compressor, some superheating of vapour is recommended after the evaporator.

A small degree of subcooling of the liquid refrigerant after the condenser is also used to reduce the mass of vapour formed during expansion, so that too many vapour bubbles do not impede the flow of liquid refrigerant through the expansion valve.

Both the superheating of vapour at the evaporator outlet and the subcooling of liquid at the condenser outlet contribute to an increase in the refrigerating effect, as shown in Fig. 14.9. The compressor discharge temperature, however, increases, due to superheat, from t'_2 to t_2 , and the load on the condenser also increases.

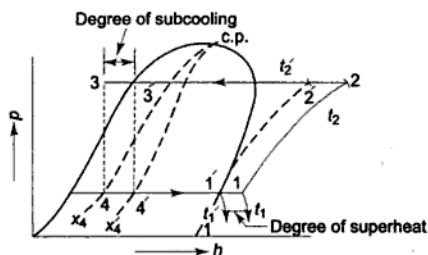

Fig. 14.9 Superheat and subcooling in a vapour compression cycle

Sometimes, a liquid-line heat exchanger is used in the plant, as shown in Fig. 14.10. The liquid is subcooled in the heat exchanger, reducing the load on the condenser and improving the COP. For 1 kg flow

$$Q_2 = h_6 - h_5, \quad Q_1 = h_2 - h_3$$

$$W_c = h_2 - h_1 \text{ and } h_1 - h_6 = h_3 - h_4$$

14.3.3 Components in a Vapour Compression Plant

Condenser It must desuperheat and then condense the compressed refrigerant. Condensers may be either air-cooled or water-cooled. An air-cooled condenser is used in small self-contained units. Water-cooled condensers are used in larger installations.

Expansion device It reduces the pressure of the refrigerant, and also regulates the flow of the refrigerant to the evaporator. Two widely used types of expansion devices are: capillary tubes and throttle valves (thermostatic expansion valves). Capillary tubes are used only for small units. Once the size and length are fixed,

the evaporator pressure, etc., gets fixed. No modification in operating conditions is possible. Throttle valves are used in larger units. These regulate the flow of the refrigerant according to the load on the evaporator.

Compressor Compressors may be of three types: (a) reciprocating, (b) rotary, and (c) centrifugal. When the volume flow rate of the refrigerant is large, centrifugal compressors are used. Rotary compressors are used for small units. Reciprocating compressors are used in plants up to 100 tonnes capacity. For plants of higher capacities, centrifugal compressors are employed.

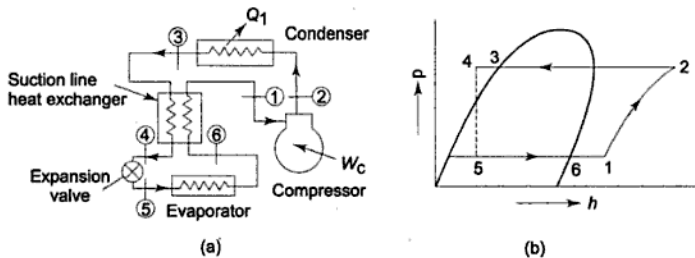

Fig. 14.10 Vapour compression cycle with a suction-line heat exchanger

In reciprocating compressors, which may be single-cylinder or multi-cylinder ones, because of clearance, leakage past the piston and valves, and throttling effects at the suction and discharge valves, the actual volume of gas drawn into the cylinder is less than the volume displaced by the piston. This is accounted for in the term *volumetric efficiency*, which is defined as

$$\eta_{\text{vol}} = \frac{\text{Actual volume of gas drawn at evaporator pressure and temperature}}{\text{Piston displacement}}$$

∴ Volume of gas handled by the compressor

$$= w \cdot v_1 (\text{m}^3/\text{s}) = \left(\frac{\pi}{4} D^2 L \frac{N}{60} n \right) \times \eta_{\text{vol}}$$

where w is the refrigerant flow rate,

v_1 is the specific volume of the refrigerant at the compressor inlet,

D and L are the diameter and stroke of the compressor,

n is the number of cylinders in the compressor, and

N is the r.p.m.

The clearance volumetric efficiency is given by Eq. (10.72)

$$\eta_{\text{vol}} = 1 + C - C \left(\frac{p_2}{p_1} \right)^{1/n}$$

where C is the clearance.

Evaporator A common type of evaporator is a coil brazed on to a plate, called a plate evaporator. In a 'flooded evaporator' the coil is filled only with a liquid

refrigerant. In an indirect expansion coil, water (up to 0°C) or brine (for temperatures between 0 and -21°C) may be chilled in the evaporator, and the chilled water or brine may then be used to cool some other medium.

14.3.4 Multistage Vapour Compression Systems

For a given condensation temperature, the lower the evaporator temperature, the higher becomes the compressor pressure ratio. For a reciprocating compressor, a high pressure ratio across a single stage means low volumetric efficiency. Also, with dry compression the high pressure ratio results in high compressor discharge temperature which may damage the refrigerant. To reduce the work of compression and improve the COP, multistage compression with intercooling may be adopted. Since the intercooler temperature may be below the temperature of available cooling water used for the condenser, the refrigerant itself may be used as the intercooling medium. Figure 14.11 shows a two-stage compression system with a direct contact heat exchanger.

As shown in Sec. 10.4, for minimum work, the intercooler pressure p_1 is the geometric mean of the evaporator and condenser pressures, p_1 and p_2 , or

$$p_1 = \sqrt{p_1 \cdot p_2}$$

By making an energy balance of the direct contact heat exchanger,

$$\dot{m}_2 h_2 + \dot{m}_1 h_6 = \dot{m}_2 h_7 + \dot{m}_1 h_3$$

$$\therefore \frac{\dot{m}_1}{\dot{m}_2} = \frac{h_2 - h_7}{h_3 - h_6}$$

The desired refrigerating effect determines the flow rate in the low pressure loop, \dot{m}_2 , as given below

$$\dot{m}_2 (h_1 - h_8) = \frac{14000}{3600} \times P$$

where P is the capacity, in tonnes of refrigeration.

$$\therefore \dot{m}_2 = \frac{3.89 P}{h_1 - h_8} \text{ kg/s}$$

Figure 14.12 shows a two-stage vapour compression system with a flash chamber intercooler, where the vapour from the flash chamber (state 9) mixes with the vapour from the LP compressor (state 2) to form vapour at state 3, which enters the HP compressor.

14.3.5 Refrigerants

The most widely used refrigerants now-a-days are a group of halogenated hydrocarbons, or chlorofluorocarbons (CFCs) marketed under the various proprietary names of freon, genetron, arcton, isotron, frigen, and, so on. These are either methane-based or ethane-based, where the hydrogen atoms are replaced by

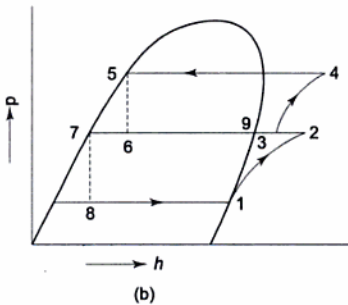
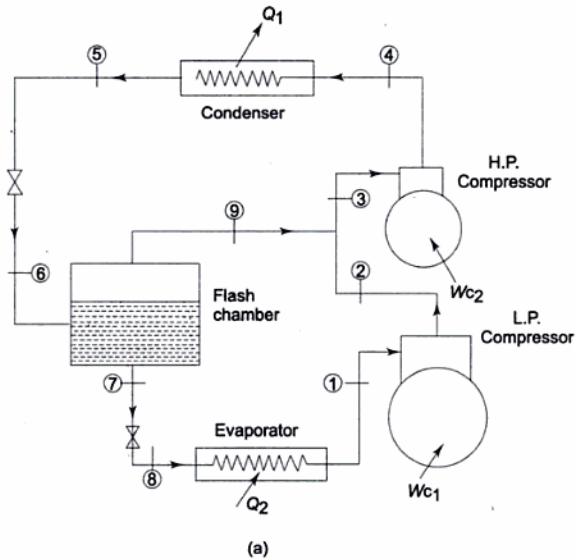

Fig. 14.12 Two-stage vapour compression system with a flash intercooler

third digit indicates the number of fluorine atoms, all other atoms in the hydrocarbon being chlorine. For example, R-110 is C_2Cl_6 , R-113 is $C_2Cl_3F_3$, R-142 is $C_2H_3ClF_2$, and so on. The use of these refrigerants is now discouraged, since these, being largely insoluble in water, move up, react with ozone in the ozone layer (which protects the earth from pernicious ultraviolet rays, and deplete it.

It was realized in mid-seventies that the CFCs not only allow more ultraviolet radiation into the earth's atmosphere, but also prevent the infrared radiation from escaping the earth to outer space, which contributes to the greenhouse effect and

hence, global warming. As a result, the use of some CFCs is banned (by Montreal Protocol, 1987) and phased out in many countries. Fully halogenated CFCs (such as R-11, R-12 and R-115) do the most damage to the ozone layer. The partially halogenated refrigerants such as R-22 have about 5% of the ozone depleting potential (ODP) of R-12. CFCs, friendly to the ozone layer that protects the earth from ultraviolet rays and which do not contribute to the greenhouse effect are being developed. The chlorine free R-134a, a recent finding, is presently replacing R-12, the most widely used refrigerant, particularly in domestic refrigerators and freezers and automotive air conditioners.

Two important parameters that need to be considered in the selection of a refrigerant are the temperatures of the two media (the refrigerated space and the environment), with which the refrigerant exchanges heat. To have reasonable heat transfer rate, a temperature difference of 5 to 10°C should be maintained between the refrigerant and the medium. If a space is to be maintained at -10°C , e.g. the refrigerant should evaporate at about -20°C (Fig. 14.13), the saturation pressure at which should be above atmospheric pressure to prevent any air leakage into the system. Again, the temperature of the refrigerant in the condenser should be above the cooling medium by about 10°C , as shown in the figure, the saturation pressure at which must be below the critical pressure of the refrigerant. If a single refrigerant cannot meet the temperature requirements (-20°C to 50°C range), two cycles with two different refrigerants can be used in series (Fig. 14.14). Such a coupled cycle makes a *cascade refrigeration system*.

Other desirable characteristics of a refrigerant are that it should be nontoxic, noncorrosive, nonflammable, and chemically stable, should have a large enthalpy of vaporization to minimize the mass flow, and should be available at low cost.

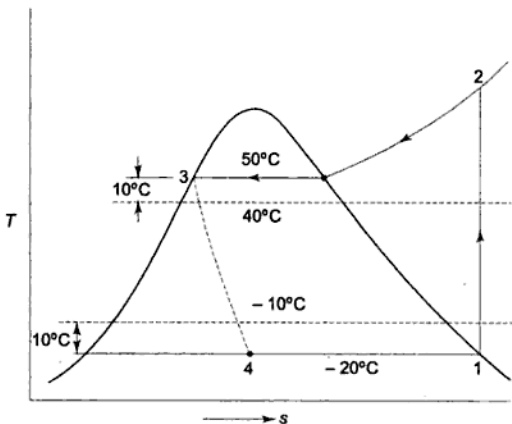

Fig. 14.13

Ammonia is widely used in food refrigeration facilities such as the cooling of fresh fruits, vegetables, meat and fish, refrigeration of beverages and dairy products such as beer, wine, milk and cheese, freezing of ice cream and ice production, low temperature refrigeration in the pharmaceutical and other process industries. The advantages of ammonia are its low cost, higher COPs and thus lower energy costs, greater detectability in the event of a leak, no effect on the ozone layer, and more favourable thermodynamic and transport properties and thus higher heat transfer coefficients requiring smaller and lower cost heat exchangers. The major drawback of ammonia is its toxicity which makes it unsuitable for domestic use.

Other fluids used as refrigerants are sulphur dioxide, methyl chloride, ethyl chloride, hydrocarbons like propane, butane, ethane, ethylene, etc. carbon dioxide, air and water.

14.4 Absorption Refrigeration Cycle

The absorption refrigeration system is a *heat operated unit* which uses a refrigerant that is *alternately absorbed and liberated from the absorbent*. In the basic absorption system, the compressor in the vapour compression cycle is *replaced by an absorber-generator assembly* involving less mechanical work. Figure 14.15 gives the basic absorption refrigeration cycle, in which *ammonia is the refrigerant and water is the absorbent*. This is known as the *aqua-ammonia absorption system*.

Ammonia vapour is vigorously absorbed in water. So when low-pressure ammonia vapour from the evaporator comes in contact in the absorber with the weak solution (the concentration of ammonia in water is low) coming from the generator, it is readily absorbed, releasing the latent heat of condensation. The

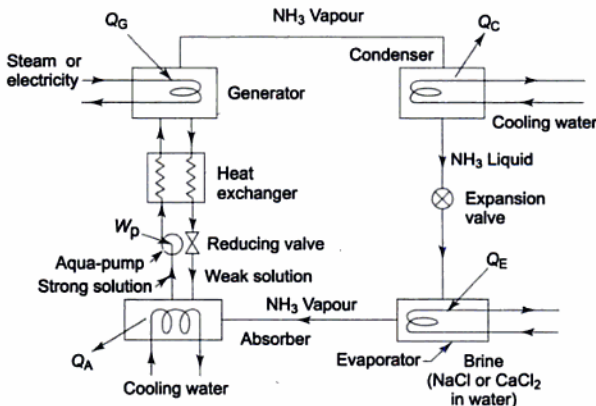

Fig. 14.15 Vapour absorption refrigeration plant-flow diagram

The final reduction in the percentage of water vapour in the ammonia going to the condenser occurs in the rectifier which is a water-cooled heat exchanger which condenses water vapour and returns it to the generator through the drip line, as shown in Fig. 14.16. The use of a suction-line heat exchanger is to reduce Q_A and increase Q_E , thus achieving a double benefit. In the absorber the weak solution is sprayed to expose a larger surface area so as to accelerate the rate of absorption of ammonia vapour.

There is another absorption refrigeration system, namely, lithium bromide-water vapour absorption (Fig. 14.17). Here the refrigerant is water and the absorbent is the solution of lithium bromide salt in water. Since water cannot be cooled below 0°C , it can be used as a refrigerant in air conditioning units. Lithium bromide solution has a strong affinity for water vapour because of its very low vapour pressure. It absorbs water vapour as fast as it is released in the evaporator.

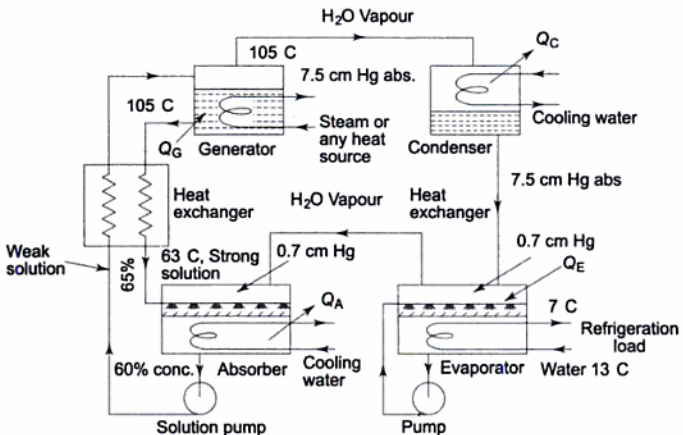

Fig. 14.17 Lithium bromide-water absorption refrigeration plant

While the vapour compression refrigeration system requires the expenditure of 'high-grade' energy in the form of shaft work to drive the compressor with the concomitant disadvantage of vibration and noise, the absorption refrigeration system requires only 'low-grade' energy in the form of heat to drive it, and it is relatively silent in operation and subject to little wear. Although the $\text{COP} = Q_E/Q_G$ is low, the absorption units are usually built when waste heat is available and they are built in relatively bigger sizes. One current application of absorption system that may grow in importance is the utilization of solar e for the generator heat source of a refrigerator for food preservation and for comfort cooling.

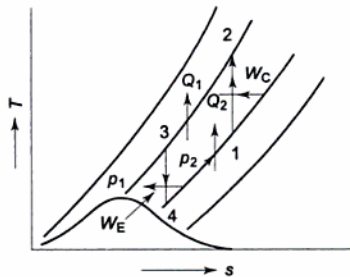
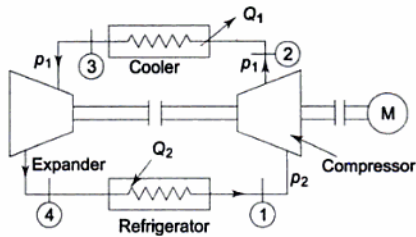

Fig. 14.22 Gas refrigeration cycle

compression system are here called the cooler and refrigerator respectively. The COP of the refrigeration cycle, assuming the gas to be ideal, is given by

$$\begin{aligned} \text{COP} &= \frac{Q_2}{W_{\text{net}}} = \frac{h_1 - h_4}{(h_2 - h_1) - (h_3 - h_4)} \\ &= \frac{T_1 - T_4}{(T_2 - T_1) - (T_3 - T_4)} = \frac{T_1 - T_4}{T_1 \left(\frac{T_2}{T_1} - 1 \right) - T_4 \left(\frac{T_3}{T_4} - 1 \right)} \end{aligned}$$

For isentropic compression and expansion

$$\frac{T_2}{T_1} = \left(\frac{p_1}{p_2} \right)^{(\gamma-1)/\gamma} = \frac{T_3}{T_4}$$

$$\therefore \text{COP} = \frac{T_1 - T_4}{(T_1 - T_4) \left(\frac{T_3}{T_4} - 1 \right)} = \frac{T_4}{T_3 - T_4}$$

Also

$$\text{COP} = \frac{1}{\left(\frac{p_1}{p_2} \right)^{(\gamma-1)/\gamma} - 1} \quad (1)$$

where p_1 is the pressure after compression and p_2 is the pressure before compression. \times

and the energy balance gives

$$\begin{aligned} \dot{m}h_2 - \dot{m}_f h_5 - (\dot{m} - \dot{m}_f)h_7 &= 0 \\ \therefore \dot{m}(h_2 - h_7) - \dot{m}_f(h_5 - h_7) &= 0 \\ Y = \frac{\dot{m}_f}{\dot{m}} &= \frac{h_2 - h_7}{h_5 - h_7} \\ \therefore Y &= \frac{h_7 - h_2}{h_7 - h_5} \end{aligned} \quad (14.6)$$

No yield is thus possible unless h_7 is greater than h_2 . The energy balance for the compressor gives

$$\dot{m}h_1 + W_c = \dot{m}h_2 + Q_R$$

where Q_R is the heat loss to the surroundings from the compressor

$$\therefore \frac{W_c}{\dot{m}} = T_1(s_1 - s_2) - (h_1 - h_2)$$

This is the *minimum work requirement*.

Specific work consumption, W

$$= \frac{W_c}{\dot{m}} \times \frac{\dot{m}}{\dot{m}_f} = \frac{W_c}{\dot{m}} \frac{1}{Y} = \frac{h_7 - h_5}{h_7 - h_2} [T_1(s_1 - s_2) - (h_1 - h_2)]$$

14.7.2 Claude System of Air Liquefaction

In the Claude system, energy is removed from the gas stream by allowing it to do some work in an expander. The flow and T - s diagrams are given in Fig. 14.25.

The gas is first compressed to pressures of about 40 atm and then passed through the first heat exchanger. Approximately 80% of the gas is then diverted from the main stream, expanded through an expander, and reunited with the return stream below the second heat exchanger. The stream to be liquefied continues through the second and third heat exchangers, and is finally expanded through an expansion valve to the liquid receiver. The cold vapour from the liquid receiver is returned through the heat exchangers to cool the incoming gas.

The yield and the specific work consumption may be computed by making the mass and energy balance as in the Linde-Hampson system.

14.8 Production of Solid Ice

Dry ice is used for low temperature refrigeration, such as to preserve ice-cream and other perishables. The property diagram of CO_2 on the p - h coordinates is given in Fig. 14.26. The schematic diagram of producing solid CO_2 and the corresponding p - h diagram are shown in Figs 14.27 and 14.28 respectively.

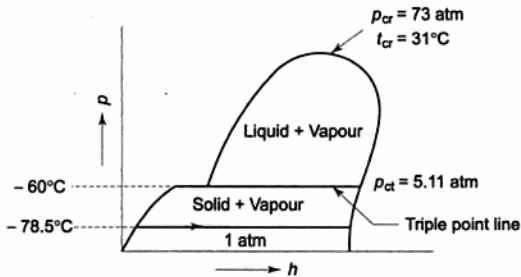

Fig. 14.26 p - h diagram of CO_2

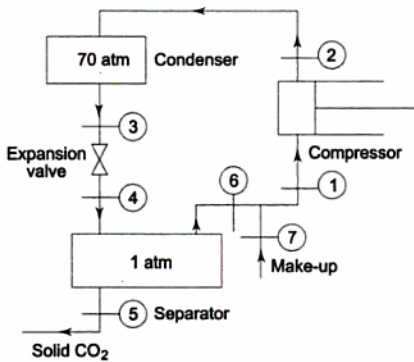

Fig. 14.27 Production of dry ice-flow diagram

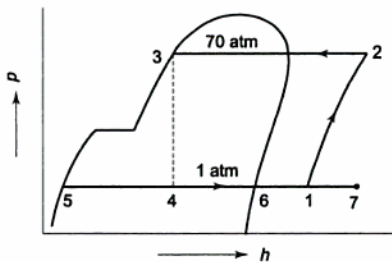

Fig. 14.28 Refrigeration cycle of a dry ice plant on p - h plot

SOLVED EXAMPLES

Example 14.1 A cold storage is to be maintained at -5°C while the surroundings are at 35°C . The heat leakage from the surroundings into the cold

storage is estimated to be 29 kW. The actual COP of the refrigeration plant used is one-third that of an ideal plant working between the same temperatures. Find the power required (in kW) to drive the plant.

Solution

$$\begin{aligned} \text{COP (Ideal)} &= \frac{T_2}{T_1 - T_2} \\ &= \frac{268}{308 - 268} = 6.7 \end{aligned}$$

$$\therefore \text{Actual COP} = 1/3 \times 6.7$$

$$= 2.23 = \frac{Q_2}{W}$$

\therefore Power required to drive the plant (Fig. Ex. 14.1)

$$\begin{aligned} W &= \frac{Q_2}{2.23} = \frac{29}{2.23} \\ &= 13 \text{ kW} \end{aligned}$$

Ans.

Example 14.2 A refrigerator uses R-134a as the working fluid and operates on an ideal vapour compression cycle between 0.14 MPa and 0.8 MPa. If the mass flow rate of the refrigerant is 0.06 kg/s, determine (a) the rate of heat removal from the refrigerated space, (b) the power input to the compressor, (c) the heat rejection rate in the condenser, and (d) the COP.

Solution From the R-134a tables, the enthalpies at the four states (Fig. Ex. 14.2) are:

$$h_1 = 236.04 \text{ kJ/kg}$$

$$s_1 = 0.9322 \text{ kJ/kg K} = s_2$$

For

$$p_2 = 0.8 \text{ MPa}, s_2 = 0.9322 \text{ kJ/kgK},$$

$$h_2 = 272.05 \text{ kJ/kg}, h_3 = h_4 = 93.42 \text{ kJ/kg}$$

$$Q_2 = 0.06 (236.04 - 93.42) = 8.56 \text{ kW}$$

Ans. (a)

$$W_c = 0.06 (272.05 - 236.04) = 2.16 \text{ kW}$$

Ans. (b)

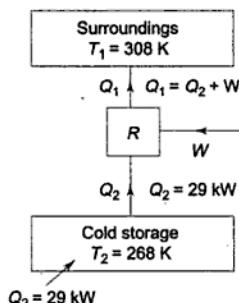

Fig. Ex.14.1

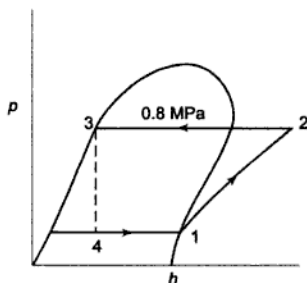

Fig. Ex.14.2

$$\begin{aligned} \text{Heat rejected to the condenser} &= w(h_2 - h_3) \\ &= 0.18 (209.41 - 74.59) \\ &= 24.27 \text{ kW} \end{aligned} \quad \text{Ans. (e)}$$

$$h_4 = h_f + x_4 h_{fg} = 26.87 + x_4 \times 156.31 = 74.59$$

$$\therefore x_4 = \frac{47.72}{156.31} = 0.305$$

$$\therefore \text{Flash gas percentage} = 30.5\% \quad \text{Ans. (f)}$$

$$\begin{aligned} \text{COP} &= \frac{h_1 - h_4}{h_2 - h_1} = \frac{183.19 - 74.59}{209.41 - 183.19} \\ &= \frac{108.60}{26.22} = 4.14 \end{aligned} \quad \text{Ans. (g)}$$

Power required to drive the compressor

$$= w(h_2 - h_1) = 0.18 \times 26.22 = 4.72 \text{ kW} \quad \text{Ans. (h)}$$

$$\text{COP (Reversible)} = \frac{T_2}{T_1 - T_2} = \frac{263}{50} = 5.26$$

$$\therefore \frac{\text{COP (Vap. Comp. cycle)}}{\text{COP (Carnot cycle)}} = \frac{4.14}{5.26} = 0.787 \quad \text{Ans.}$$

Example 14.4 A Refrigerant-12 vapour compression plant producing 10 tonnes of refrigeration operates with condensing and evaporating temperatures of 35°C and -10°C respectively. A suction line heat exchanger is used to subcool the saturated liquid leaving the condenser. Saturated vapour leaving the evaporator is superheated in the suction line heat exchanger to the extent that a discharge temperature of 60°C is obtained after isentropic compression. Determine (a) the subcooling achieved in the heat exchanger, (b) the refrigerant flow rate in kg/s, (c) the cylinder dimensions of the two-cylinder compressor, if the speed is 900 rpm, stroke-to-bore ratio is 1.1, and the volumetric efficiency is 80%, (d) the COP of the plant, and (e) the power required to drive the compressor in kW.

Solution From the p - h chart of R-12, the property values at the states, as shown in Fig. Ex. 14.4,

$$h_3 = 882, h_2 = 1034$$

$$h_6 = 998, h_1 = 1008 \text{ kJ/kg}$$

$$v_1 = 0.084 \text{ m}^3/\text{kg}$$

$$h_3 - h_4 = h_1 - h_6$$

$$882 - h_4 = 1008 - 998 = 10$$

$$\therefore h_4 = 872 \text{ kJ/kg}$$

$$\therefore t_4 = 25^\circ\text{C}$$

So 10°C subcooling is achieved in the heat exchanger. Refrigeration effect
 $= h_6 - h_5 = 998 - 872 = 126 \text{ kJ/kg}$ Ans. (a)

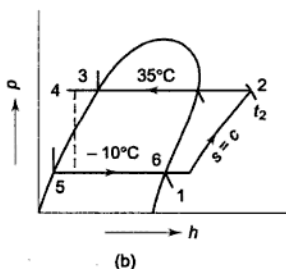
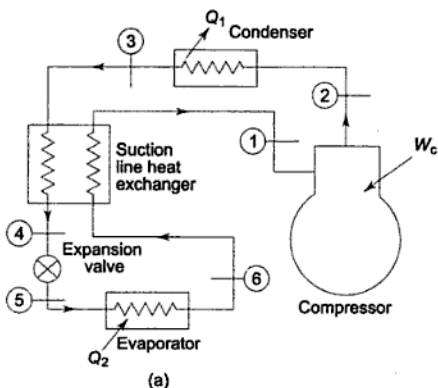

Fig. Ex.14.4

$$\therefore \text{Refrigerant flow rate} = \frac{10 \times 14000}{126} = 1110 \text{ kg/h} \quad \text{Ans. (b)}$$

$$= 0.31 \text{ kg/s}$$

$$\text{Volume flow rate} = w \cdot v_1 = 1110 \times 0.084 = 93 \text{ m}^3/\text{h}$$

$$\text{Compressor displacement} = \frac{93}{0.8} = 116 \text{ m}^3/\text{h} = 1.94 \text{ m}^3/\text{min}$$

This is equal to $\frac{\pi}{4} D^2 L N n$

where D = diameter

L = stroke

N = rpm

n = number of cylinders of the compressor.

$$\frac{\pi}{4} D^2 \times 1.1D \times 900 \times 2 = 1.94 \text{ m}^3/\text{min}$$

$$D^3 = 1250 \text{ cm}^3$$

$$\begin{aligned}\dot{W}_c &= \dot{m}_2(h_2 - h_1) + \dot{m}_1(h_4 - h_3) \\ &= 0.0954 \times 169 + 0.124 \times 184.6 = 16.19 + 22.89 \\ &= 39.08 \text{ kW}\end{aligned}$$

$$\text{COP} = \frac{30 \times 3.89}{39.08} = 2.986$$

Single stage

$$h_1 = 1404.6 \quad h_2 = 1805.1$$

$$h_3 = 371.7 = h_4$$

$$\dot{m} = \frac{30 \times 3.89}{1404.6 - 371.7} = \frac{116.7}{1032.9}$$

$$= 0.113 \text{ kg/s}$$

$$\begin{aligned}\dot{W}_c &= \dot{m}(h_2 - h_1) = 0.113 \times 400.5 \\ &= 45.26 \text{ kW}\end{aligned}$$

$$\therefore \text{COP} = \frac{116.7}{45.26} = 2.578$$

Increase in work of compression (for single stage)

$$= \frac{45.26 - 39.08}{39.08} \times 100 = 15.81\%$$

Increase in COP for 2-stage compression

$$= \frac{2.986 - 2.578}{2.578} \times 100 = 15.82\%$$

Example 14.6 In an aqua-ammonia absorption refrigerator system, heat is supplied to the generator by condensing steam at 0.2 MPa, 90% quality. The temperature to be maintained in the refrigerator is -10°C , and the ambient temperature is 30°C . Estimate the maximum COP of the refrigerator.

If the actual COP is 40% of the maximum COP and the refrigeration load is 20 tonnes, what will the required steam flow rate be?

Solution At 0.2 MPa, from the steam table (Fig. Ex. 14.6)

$$t_{\text{sat}} = 120.2^\circ\text{C}, \quad h_{\text{fg}} = 2201.9 \text{ kJ/kg}$$

The maximum COP of the absorption refrigeration system is given by Eq. (14.4)

$$(\text{COP})_{\text{max}} = \frac{(T_1 - T_2)T_R}{(T_2 - T_R)T_1}$$

where T_1 = generator temperature
 $= 120.2 + 273 = 393.2 \text{ K}$

T_2 = condenser and absorber temperature
 $= 30 + 273 = 303 \text{ K}$

pressure before re-entering the compressor which is driven by the turbine. Assuming air to be an ideal gas, determine the COP of the refrigerator, the driving power required, and the air mass flow rate.

Solution Given: (Fig. Ex. 14.7)

$$T_1 = 277 \text{ K}, T_3 = 273 + 55 = 328 \text{ K}$$

$$\frac{T_{2s}}{T_1} = \left(\frac{P_2}{P_1} \right)^{(\gamma-1)/\gamma}$$

$$\therefore T_{2s} = 277(3)^{0.4/1.4} = 379 \text{ K}$$

$$T_{2s} - T_1 = 102 \text{ K}$$

$$\therefore T_2 - T_1 = \frac{102}{0.72} = 141.8 \text{ K}$$

$$\frac{T_{4s}}{T_3} = \left(\frac{P_2}{P_1} \right)^{(\gamma-1)/\gamma}$$

$$\therefore T_{4s} = 328(3)^{0.4/1.4} = \frac{328}{1.368} = 240 \text{ K}$$

$$T_3 - T_{4s} = 88 \text{ K}$$

$$\therefore T_3 - T_4 = 0.78 \times 88 = 68.6 \text{ K}$$

$$\therefore T_4 = 259.4 \text{ K}$$

$$\text{Refrigerating effect} = c_p(T_1 - T_4) = 17.6c_p \text{ kJ/kg}$$

$$\begin{aligned} \text{Net work input} &= c_p[(T_2 - T_1) - (T_3 - T_4)] \\ &= c_p[141.8 - 68.6] = 73.2c_p \text{ kJ/kg} \end{aligned}$$

$$\therefore \text{COP} = \frac{17.6c_p}{73.2c_p} = 0.24 \quad \text{Ans.}$$

Driving power required

$$= \frac{3 \times 14000}{0.24 \times 3600} = 48.6 \text{ kW} \quad \text{Ans.}$$

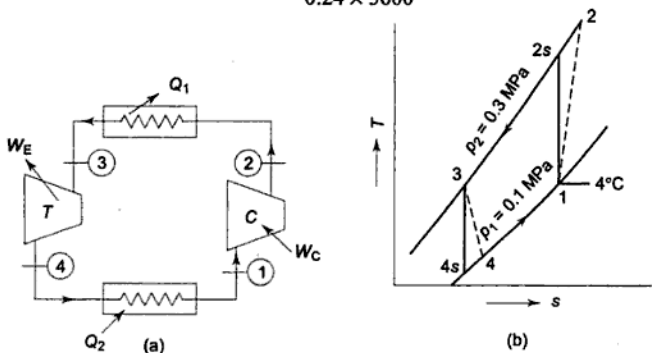

Fig. Ex.14.7

- 14.28 How can a heat pump be used for (a) space heating (b) year-round air conditioning?
- 14.29 How is a reversed Brayton cycle used for refrigeration?
- 14.30 Why is the COP of a gas cycle refrigeration system low?
- 14.31 Why is gas cycle refrigeration preferred in aircraft?
- 14.32 What is the principle of the Linde-Hampson system for liquefaction of air?
- 14.33 Derive the expressions of liquid yield and the minimum work requirement in a Linde-Hampson system.
- 14.34 How does Claude cycle differ from a Linde-Hampson cycle in the context of the liquefaction of air.
- 14.35 With the help of flow and p - h diagrams, explain how dry ice is produced.

PROBLEMS

- 14.1 A refrigerator using R-134a operates on an ideal vapour compression cycle between 0.12 and 0.7 MPa. The mass flow of refrigerant is 0.05 kg/s. Determine (a) the rate of heat removal from the refrigerated space, (b) the power input to the compressor, (c) the rate of heat rejection to the environment, and (d) the COP.
Ans. (a) 7.35 kW, (b) 1.85 kW, (c) 9.20 kW, (d) 3.97
- 14.2 A Refrigerant-12 vapour compression cycle has a refrigeration load of 3 tonnes. The evaporator and condenser temperatures are -20°C and 40°C respectively. Find (a) the refrigerant flow rate in kg/s, (b) the volume flow rate handled by the compressor in m^3/s , (c) the work input to the compressor in kW, (d) the heat rejected in the condenser in kW, and (e) the isentropic discharge temperature.
If there is 5 C deg. of superheating of vapour before it enters the compressor, and 5 C deg. subcooling of liquid before it flows through the expansion valve, determine the above quantities.
- 14.3 A 5 tonne R-12 plant maintains a cold store at -15°C . The refrigerant flow rate is 0.133 kg/s. The vapour leaves the evaporator with 5 C deg. superheat. Cooling water is available in plenty at 25°C . A suction line heat exchanger subcools the refrigerant before throttling. Find (a) the compressor discharge temperature, (b) the COP, (c) the amount of subcooling in C deg., and (d) the cylinder dimensions of the compressor, if the speed is 900 rpm, stroke-to-bore ratio is 1.2, and volumetric efficiency is 95%.
Allow approximately 5°C temperature difference in the evaporator and condenser.
Ans. (a) 66°C , (b) 4.1 (c) 125°C , (d) 104.5 mm, 125 mm
- 14.4 A vapour compression refrigeration system uses R-12 and operates between pressure limits of 0.745 and 0.15 MPa. The vapour entering the compressor has a temperature of -10°C and the liquid leaving the condenser is at 28°C . A refrigerating load of 2 kW is required. Determine the COP and the swept volume of the compressor if it has a volumetric efficiency of 76% and runs at 600 rpm.
Ans. 4.15, 243 cm^3
- 14.5 A food-freezing system requires 20 tonnes of refrigeration at an evaporator temperature of -35°C and a condenser temperature of 25°C . The refrigerant, R-12, is subcooled 4°C before entering the expansion valve, and the vapour is

- 14.14 A heat pump is to use an R-12 cycle to operate between outdoor air at -1°C and air in a domestic heating system at 40°C . The temperature difference in the evaporator and the condenser is 8°C . The compressor efficiency is 80%, and the compression begins with saturated vapour. The expansion begins with saturated liquid. The combined efficiency of the motor and belt drive is 75%. If the required heat supply to the warm air is 43.6 kW, what will be the electrical load in kW?
- 14.15 An ideal (Carnot) refrigeration system operates between the temperature limits of -30°C and 25°C . Find the ideal COP and the power required from an external source to absorb 3.89 kW at low temperature.
If the system operates as a heat pump, determine the COP and the power required to discharge 3.89 kW at high temperature.
- 14.16 An ammonia-absorption system has an evaporator temperature of -12°C and a condenser temperature of 50°C . The generator temperature is 150°C . In this cycle, 0.42 kJ is transferred to the ammonia in the evaporator for each kJ transferred to the ammonia solution in the generator from the high temperature source.
It is desired to compare the performance of this cycle with the performance of a similar vapour compression cycle. For this, it is assumed that a reservoir is available at 150°C , and that heat is transferred from this reservoir to a reversible engine which rejects heat to the surroundings at 25°C . This work is then used to drive an ideal vapour compression system with ammonia as the refrigerant. Compare the amount of refrigeration that can be achieved per kJ from the high temperature source in this case with the 0.42 kJ that can be achieved in the absorption system.
- 14.17 An R-12 plant is to cool milk from 30°C to 1°C involving a refrigeration capacity of 10 tonnes. Cooling water for the condenser is available at 25°C and a 5 C deg. rise in its temperature is allowable. Determine the suitable condensing and evaporating temperatures, providing a minimum of 5 C deg. differential, and calculate the theoretical power required in kW and the cooling water requirement in kg/s. Also, find the percentage of flash gas at the end of the throttling. Assume a 2 C deg. subcooling in the liquid refrigerant leaving the condenser.
- 14.18 The following data pertain to an air cycle refrigeration system for an aircraft:
Capacity 5 tonnes
Cabin air inlet temperature 15°C and outlet temperature 25°C
Pressure ratio across the compressor 5
The aircraft is flying at 0.278 km/s where the ambient conditions are 0°C and 80 kPa. Find the COP and the cooling effectiveness of the heat exchanger. The cabin is at 0.1 MPa, and the cooling turbine powers the circulating fans.
- 14.19 A water cooler supplies chilled water at 7°C when water is supplied to it at 27°C at a rate of 0.7 litres/min., while the power consumed amounts to 200 watts. Compare the COP of this refrigeration plant with that of the ideal refrigeration cycle for a similar situation.
- 14.20 A refrigerating plant of 8 tonnes capacity has an evaporation temperature of -8°C and condenser temperature of 30°C . The refrigerant, R-12, is subcooled 5°C before entering the expansion valve and the vapour is superheated 6°C before leaving the evaporator coil. The compression of the refrigerant is isentropic. If there is a suction pressure drop of 20 kPa through the valves, and discharge pressure drop of 10 kPa through the valves, determine the COP of the plant,

15

Psychrometrics

The properties of the mixtures of ideal gases were presented in Chapter 10. The name 'psychrometrics' is given to the study of the properties of airwater vapour mixtures. Atmospheric air is considered to be a mixture of dry air and water vapour. The control of moisture (or water vapour) content in the atmosphere is essential for the satisfactory operation of many processes involving *hygroscopic* materials like paper and textiles, and is important in comfort air conditioning.

15.1 Properties of Atmospheric Air

Dry air is a mechanical mixture of the gases: oxygen, nitrogen, carbon dioxide, hydrogen, argon, neon, krypton, helium, ozone, and xenon. However, oxygen and nitrogen make up the major part of the combination. Dry air is considered to consist of 21% oxygen and 79% nitrogen by volume, and 23% oxygen and 77% nitrogen by mass. Completely dry air does not exist in nature. Water vapour in varying amounts is diffused through it. If p_a and p_w are the partial pressures of dry air and water vapour respectively, then by Dalton's law of partial pressures

$$p_a + p_w = p$$

where p is the atmospheric pressure.

\therefore Mole-fraction of dry air, x_a

$$= \frac{p_a}{p} = p_a \quad (\because p = 1 \text{ atm.})$$

and mole fraction of water vapour, x_w

$$= \frac{p_w}{p} = p_w$$

Since p_w is very small, the saturation temperature of water vapour at p_w is less than atmospheric temperature, t_{atm} (Fig. 15.1). So the water vapour in air exists in the *superheated state*, and air is said to be *unsaturated*.

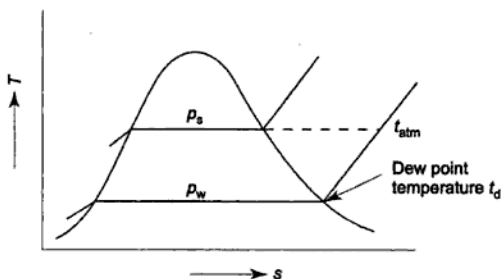

Fig. 15.1 States of water vapour in mixture

Relative humidity (R.H., ϕ) is defined as the ratio of partial pressure of water vapour, p_w , in a mixture to the saturation pressure, p_s , of pure water, at the same temperature of the mixture (Fig. 15.1)

$$\therefore \text{R.H.}(\phi) = \frac{p_w}{p_s}$$

If water is injected into unsaturated air in a container, water will evaporate, which will increase the moisture content of the air, and p_w will increase. This will continue till air becomes saturated at that temperature, and there will be no more evaporation of water. For saturated air, the relative humidity is 100%. Assuming water vapour as an ideal gas

$$p_w V = m_w R_{\text{H}_2\text{O}} T = n_w \bar{R} T$$

and

$$p_s V = m_s R_{\text{H}_2\text{O}} T = n_s \bar{R} T$$

where V is the volume and T the temperature of air, the subscripts w and s indicating the unsaturated and saturated states of air respectively.

$$\begin{aligned} \phi &= \frac{p_w}{p_s} = \frac{m_w}{m_s} \\ &= \frac{\text{mass of water vapour in a given volume of air at temperature } T}{\text{mass of water vapour when the same volume of air is saturated at temperature } T} \\ &= \frac{n_w}{n_s} = \frac{x_w}{x_s} \end{aligned}$$

Specific humidity or humidity ratio, W , is defined as the mass of water vapour (or moisture) per unit mass of dry air in a mixture of air and water vapour.

If

G = mass of dry air

m = mass of water vapour

$$W = \frac{m}{G}$$

Specific humidity is the maximum when air is saturated at temperature T , or

$$W_{\max} = W_s = \frac{m_s}{G}$$

If dry air and water vapour behave as ideal gases

$$p_w V = m R_w T$$

$$p_a V = G R_a T$$

$$\therefore W = \frac{m}{G} = \frac{p_w}{p_a} \cdot \frac{R_a}{R_w} = \frac{p_w}{p - p_w} \frac{8.3143/28.96}{8.3143/18}$$

$$\therefore W = 0.622 \frac{p_w}{p - p_w} \quad (15.1)$$

where p , is the atmospheric pressure. If p_w is constant, W remains constant.

If air is saturated at temperature T

$$W = W_s = 0.622 \frac{p_w}{p - p_s}$$

where p_s is the saturation pressure of water vapour at temperature T .

The degree of saturation, μ , is the ratio of the actual specific humidity and the saturated specific humidity, both at the same temperature T .

$$\begin{aligned} \therefore \mu &= \frac{W}{W_s} = \frac{0.622 \frac{p_w}{p - p_w}}{0.622 \frac{p_s}{p - p_s}} \\ &= \frac{p_w}{p_s} \cdot \frac{p - p_s}{p - p_w} \end{aligned}$$

If $\phi = \frac{p_w}{p_s} = 0$, $p_w = 0$, $x_w = 0$, $W = 0$, i.e. for dry air, $\mu = 0$

If $\phi = 100\%$, $p_w = p_s$, $W = W_s$, $\mu = 1$

Therefore, μ varies between 0 and 1.

If a mixture of air and superheated (or unsaturated) water vapour is cooled at constant pressure, the partial pressure of each constituent remains constant until the water vapour reaches the saturated state. Further cooling causes condensation. The temperature at which water vapour starts condensing is called the *dew point temperature*, t_{dp} , of the mixture (Fig. 15.1). It is equal to the saturation temperature at the partial pressure, p_w , of the water vapour in the mixture.

Dry bulb temperature (dbt) is the temperature recorded by the thermometer with a dry bulb.

Wet bulb temperature (wbt) is the temperature recorded by a thermometer when the bulb is enveloped by a cotton wick saturated with water. As the air stream flows past it, some water evaporates, taking the latent heat from the water-soaked wick, thus decreasing its temperature. Energy is then transferred to the

wick from the air. When equilibrium condition is reached, there is a balance between energy removed from the water film by evaporation and energy supplied to the wick by heat transfer, and the temperature recorded is the wet bulb temperature.

A *psychrometer* is an instrument which measures both the dry bulb and the wet bulb temperatures of air. Figure 15.2 shows a continuous psychrometer with a fan for drawing air over the thermometer bulbs. A sling psychrometer has the two thermometers mounted on a frame with a handle. The handle is rotated so that there is good air motion. The wet bulb temperature is the *lowest temperature* recorded by the moistened bulb.

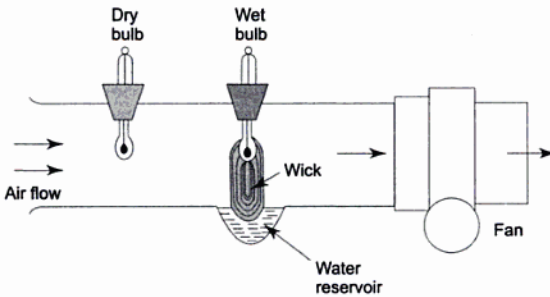

Fig. 15.2 Dry and wet bulb temperatures

At any dbt, the greater the depression (difference) of the wbt reading below the dbt, the smaller is the amount of water vapour held in the mixture.

When unsaturated air flows over a long sheet of water (Fig. 15.3) in an insulated chamber, the water evaporates, and the specific humidity of the air increases. Both the air and water are cooled as evaporation takes places. The process continues until the energy transferred from the air to the water is equal to the energy required to vaporize the water. When this point is reached, thermal equilibrium exists with respect to the water, air and water vapour, and consequently the air is saturated. The equilibrium temperature is called the *adiabatic saturation temperature* or the *thermodynamic wet bulb temperature*.

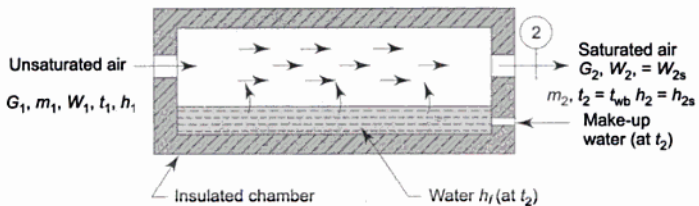

Fig. 15.3 Adiabatic saturation process

The make-up water is introduced at this temperature to make the water level constant.

The 'adiabatic' cooling process is shown in Fig. 15.4 for the vapour in the air-vapour mixture. Although the total pressure of the mixture is constant, the partial pressure of the vapour increases, and in the saturated state corresponds to the adiabatic saturation temperature. The vapour is initially at the dbt t_{db1} and is cooled adiabatically to the dbt t_{db2} which is equal to the adiabatic saturation temperature t_{wb2} . The adiabatic saturation temperature and the wet bulb temperature are taken to be equal for all practical purposes. The wbt lies between the dbt and dpt.

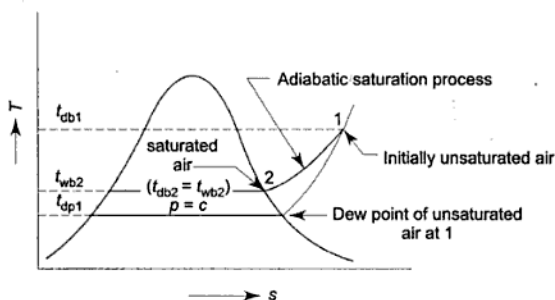

Fig. 15.4 Adiabatic cooling process on T - s plot

Since the system is insulated and no work is done, the first law yields

$$Gh_{a1} + m_1 h_{w1} + (m_2 - m_1)h_{f2} = Gh_{a2} + m_2 h_{w2}$$

where $(m_2 - m_1)$ is the mass of water added, h_{f2} is the enthalpy of the liquid water at $t_2 (= t_{wb2})$, h_a is the specific enthalpy of dry air, and h_w is the specific enthalpy of water vapour in air. Dividing by G , and since $h_{w2} = h_{g2}$

$$h_{a1} + W_1 h_{w1} + (W_2 - W_1)h_{f2} = h_{a2} + W_2 h_{g2} \quad (15.2)$$

Solving for W_1

$$\begin{aligned} W_1 &= \frac{(h_{a2} - h_{a1}) + W_2 (h_{g2} - h_{f2})}{h_{w2} - h_{f1}} \\ &= \frac{c_{pa} (T_2 - T_1) + W_2 \cdot h_{fg2}}{h_{w1} - h_{f2}} \end{aligned} \quad (15.3)$$

where

$$W_2 = \frac{m_2}{G} = \frac{m_s}{G} = 0.622 \frac{p_s}{p - p_s}$$

The enthalpy of the air-vapour mixture is given by

$$Gh = Gh_a + mh_w$$

where h is the enthalpy of the mixture per kg of dry air (it is not the specific enthalpy of the mixture)

The constant wbt line represents the adiabatic saturation process. It also coincides with the constant enthalpy line. To show this, let us consider the energy balance for the adiabatic saturation process (Eq. 15.2).

$$h_{a1} + W_1 h_{w1} + (W_2 - W_1) h_{f2} = h_{a2} + W_2 h_{w2}$$

Since $h_a + Wh_w = h$ kJ/kg dry air (equation 15.4)

$$h_1 - W_1 h_{f2} = h_2 - W_2 h_{f2}$$

where subscript 2 refers to the saturation state, and subscript 1 denotes any state along the adiabatic saturation path. Therefore

$$h - Wh_{f2} = \text{constant}$$

Since Wh_{f2} is small compared to h (of the order of 1 or 2%)

$$h = \text{constant}$$

indicating that the enthalpy of the mixture remains constant during an adiabatic saturation process.

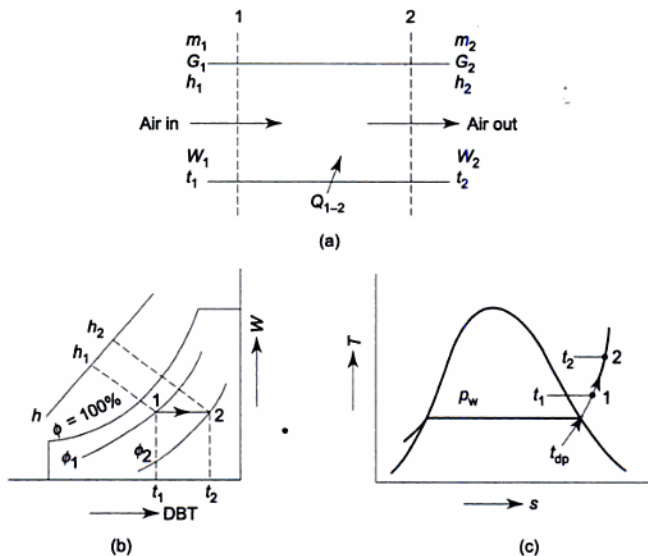
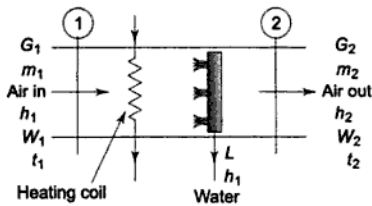

Fig. 15.6 Sensible heating

15.3 Psychrometric Processes

(a) **Sensible Heating or Cooling (at $W = \text{Constant}$)** Only the dry bulb temperature of air changes. Let us consider sensible heating of air [Fig. 15.6(a), (b), (c)] Balance of

$$\text{Dry air} \quad G_1 = G_2$$



(a)

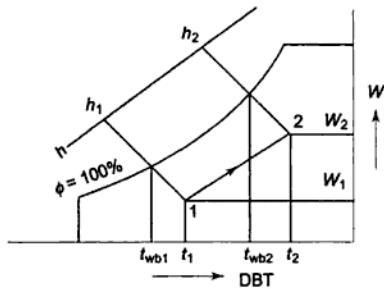

(b)

Fig. 15.9 Heating and humidification

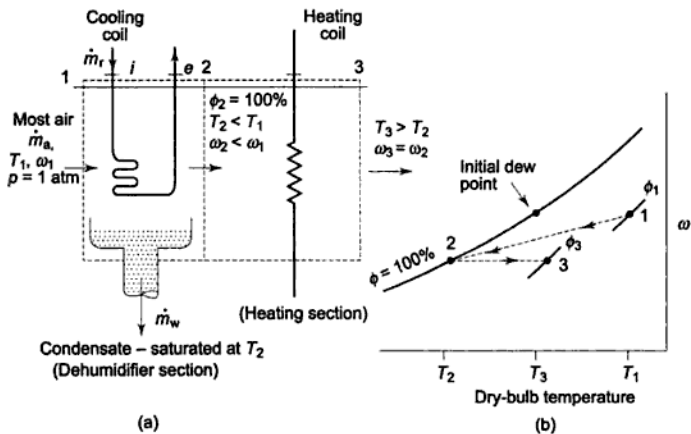

(a)

(b)

Fig. 15.10 Dehumidification with heating (a) Equipment schematic (b) Psychrometric chart representation

$$\begin{aligned}
 G_1 + G_2 &= G_3 \\
 G_1 W_1 + G_2 W_2 &= G_3 W_3 \\
 G_1 h_1 + G_2 h_2 &= G_3 h_3
 \end{aligned}$$

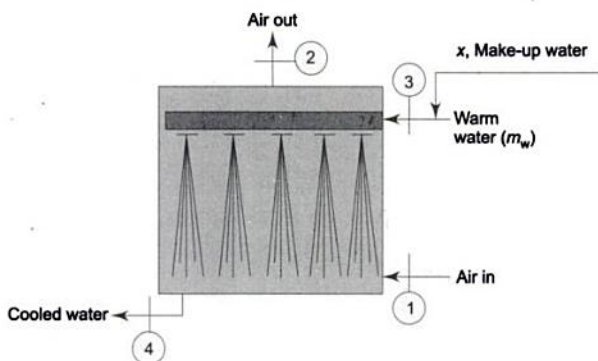

Fig. 15.14 Cooling tower

The difference in temperature of the cooled-water temperature and the wet bulb temperature of the entering air is known as the *approach*. The *range* is the temperature difference between the inlet and exit states of water. Cooling towers are rated in terms of approach and range.

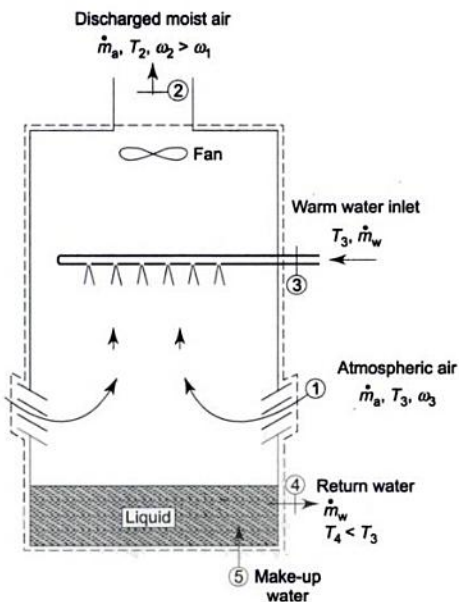

Fig. 15.15 Schematic of a cooling tower

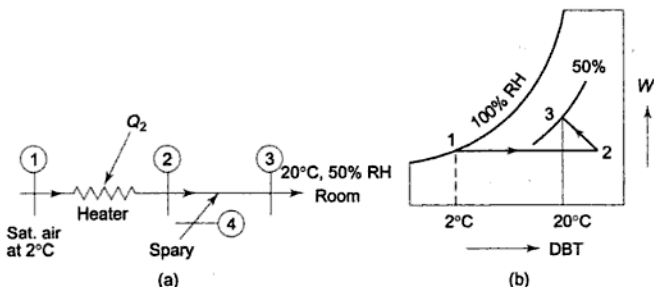

Fig. Ex. 15.3

$$\phi_3 = \frac{p_{w3}}{(p_{\text{sat}})_{t_3}} = \frac{p_{w3}}{2.339} = 0.50$$

∴

$$p_{w3} = 1.17 \text{ kPa}$$

∴

$$p_{a3} = 101.3 - 1.17 = 100.13 \text{ kPa}$$

$$W_3 = 0.622 \frac{p_{w3}}{p_{a3}} = 0.622 \times \frac{1.17}{100.13} = 0.00727$$

$$\phi_1 = \frac{p_{w1}}{(p_{\text{sat}})_{2^\circ\text{C}}} = 1.00$$

At

$$2^\circ\text{C}, p_{\text{sat}} = 0.7156 \text{ kPa}$$

∴

$$p_{w1} = 0.7156 \text{ kPa}$$

$$p_{a1} = 101.3 - 0.7156 = 100.5844 \text{ kPa}$$

$$W_1 = 0.622 \frac{0.7156}{100.5844} = 0.00442$$

$$W_3 - W_1 = 0.00727 - 0.00442 = 0.00285 \text{ kg vap./kg dry air}$$

$$v_{a3} = \frac{R_a T_3}{p_{a3}} = \frac{0.287 \times 293}{100.13} = 0.84 \text{ m}^3/\text{kg dry air}$$

∴

$$\begin{aligned} \text{Spray water} &= 0.00285 \frac{\text{kg vap.}}{\text{kg dry air}} \times \frac{\text{kg dry air}}{0.84 \text{ m}^3} \\ &= 0.00339 \text{ kg moisture/m}^3 \end{aligned}$$

Ans.

$$G_2 h_2 + m_{w4} h_4 = G_3 h_3$$

∴

$$h_2 + (W_3 - W_2) h_4 = h_3$$

$$h_{a2} + W_2 h_{w2} + (W_3 - W_2) h_4 = h_{a3} + W_3 h_{w3}$$

∴

$$c_p(t_3 - t_2) + W_3 h_{w3} - W_2 h_{w2} - (W_3 - W_2) h_4 = 0$$

From the steam tables, at $p_w = 1.17 \text{ kPa}$

$$h_g = 2518 \text{ kJ/kg and } t_{\text{sat}} = 9.65^\circ\text{C}$$

$$\begin{aligned}
 &1.005(20 - t_2) + 0.00727 [2518 + 1.884(20 - 9.65)] \\
 &\quad - 0.00442 [2518 + 1.884(t_2 - 9.65)] \\
 &\quad - 0.00285 \times 10 = 0
 \end{aligned}$$

$$\therefore t_2 = 27.2^\circ\text{C}$$

Ans.

Example 15.4 An air conditioning system is designed under the following conditions:

Outdoor conditions— 30°C dbt, 75% R.H.

Required indoor condition— 22°C dbt, 70% R.H.

Amount of free air circulated— $3.33 \text{ m}^3/\text{s}$

Coil dew point temperature— 14°C

The required condition is achieved first by cooling and dehumidification and then by heating. Estimate (a) the capacity of the cooling coil in tonnes, (b) the capacity of the heating coil in kW, and (c) the amount of water vapour removed in kg/s.

Solution The processes are shown in Fig. Ex. 15.4. The property values, taken from the psychrometric chart, are

$$h_1 = 82, h_2 = 52, h_3 = 47, h_4 = 40 \text{ kJ/kg dry air}$$

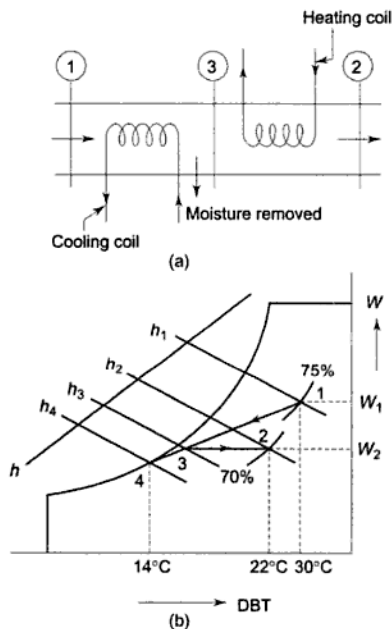

Fig. Ex. 15.4

$$W_1 = 0.020, W_2 = W_3 = 0.0115 \text{ kg vap./kg dry air}$$

$$v_1 = 0.887 \text{ m}^3/\text{kg dry air}$$

$$G = \frac{3.33}{0.887} = 3.754 \text{ kg dry air/sec}$$

$$\therefore \text{Cooling coil capacity} = G(h_1 - h_3) = 3.754(82 - 47) \text{ kJ/s}$$

$$= \frac{3.754 \times 35 \times 3600}{14,000} = 33.79 \text{ tonnes} \quad \text{Ans. (a)}$$

$$\text{Capacity of the heating coil} = G(h_2 - h_3) = 3.754(52 - 47) \text{ kJ/s}$$

$$= 3.754 \times 5 = 18.77 \text{ kW} \quad \text{Ans. (b)}$$

$$\text{Rate of water vapour removed} = G(W_1 - W_3)$$

$$= 3.754 \times (0.0200 - 0.0115)$$

$$= 0.0319 \text{ kg/s} \quad \text{Ans. (c)}$$

Example 15.5 Air at 20°C, 40% RH is mixed adiabatically with air at 40°C, 40% RH in the ratio of 1 kg of the former with 2 kg of the latter (on dry basis). Find the final condition of air.

Solution Figure Ex. 15.5 shows the mixing process of two air streams. The equations

$$G_1 + G_2 = G_3$$

$$G_1 W_1 + G_2 W_2 = G_3 W_3$$

$$G_1 h_1 + G_2 h_2 = G_3 h_3$$

result in

$$\frac{W_2 - W_3}{W_3 - W_1} = \frac{h_2 - h_3}{h_3 - h_1} = \frac{G_1}{G_2}$$

From the psychrometric chart

$$W_1 = 0.0058, W_2 = 0.0187 \text{ kg vap./kg dry air}$$

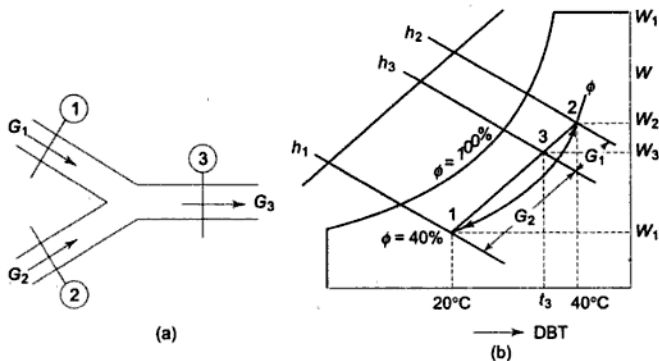

Fig. Ex. 15.5

$$h_1 = 35, h_2 = 90 \text{ kJ/kg dry air}$$

$$\therefore \frac{0.0187 - W_3}{W_3 - 0.0058} = \frac{G_1}{G_2} = \frac{1}{2}$$

$$\begin{aligned} \therefore W_3 &= \frac{2}{3} \times 0.0187 + \frac{1}{3} \times 0.0058 \\ &= 0.0144 \text{ kg vap./kg dry air} \end{aligned}$$

Again

$$\frac{h_2 - h_3}{h_3 - h_1} = \frac{G_1}{G_2} = \frac{1}{2}$$

$$\begin{aligned} \therefore h_3 &= \frac{2}{3} h_2 = \frac{1}{3} h_1 = \frac{2}{3} \times 90 + \frac{1}{3} \times 35 \\ &= 71.67 \text{ kJ/kg dry air} \end{aligned}$$

\(\therefore\) Final condition of air is given by

$$W_3 = 0.0144 \text{ kg vap./kg dry air}$$

$$h_3 = 71.67 \text{ kJ/kg dry air}$$

Example 15.6 Saturated air at 21°C is passed through a drier so that its final relative humidity is 20%. The drier uses silica gel adsorbent. The air is then passed through a cooler until its final temperature is 21°C without a change in specific humidity. Find out (a) the temperature of air at the end of the drying process, (b) the heat rejected in kJ/kg dry air during the cooling process, (c) the relative humidity at the end of the cooling process, (d) the dew point temperature at the end of the drying process, and (e) the moisture removed during the drying process in kg vap./kg dry air.

Solution From the psychrometric chart (Fig.Ex. 15.6)

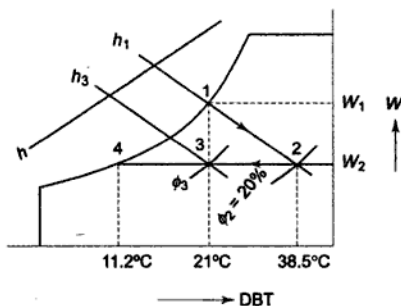

Fig. Ex. 15.6

$$T_2 = 38.5^\circ\text{C}$$

Ans. (a)

$$h_1 - h_3 = 60.5 - 42.0 = 18.5 \text{ kJ/kg dry air}$$

Ans. (b)

Example 15.8 Water at 30°C flows into a cooling tower at the rate of 1.15 kg per kg of air. Air enters the tower at a dbt of 20°C and a relative humidity of 60% and leaves it at a dbt of 28°C and 90% relative humidity. Make-up water is supplied at 20°C. Determine: (i) the temperature of water leaving the tower, (ii) the fraction of water evaporated, and (iii) the approach and range of the cooling tower.

Solution Properties of air entering and leaving the tower (Fig. 15.13) are

$$t_{wb1} = 15.2^\circ\text{C}$$

$$t_{wb2} = 26.7^\circ\text{C}$$

$$h_1 = 43 \text{ kJ/kg dry air}$$

$$h_2 = 83.5 \text{ kJ/kg dry air}$$

$$W_1 = 0.0088 \text{ kg water vapour/kg dry air}$$

$$W_2 = 0.0213 \text{ kg water vapour/kg dry air}$$

Enthalpies of the water entering the tower and the make-up water are

$$h_{w3} = 125.8 \text{ kJ/kg} \quad h_m = 84 \text{ kJ/kg}$$

From the energy balance Eq. (15.5),

$$\begin{aligned} h_{w3} - h_{w4} &= \frac{G}{m_w} [(h_2 - h_1) - (W_2 - W_1)h_w] \\ &= \frac{1}{1.15} [(83.5 - 43) - (0.0213 - 0.0088) 84] \\ &= 34.2 \text{ kJ/kg} \end{aligned}$$

Temperature drop of water

$$t_{w3} - t_{w4} = \frac{34.2}{4.19} = 30 - t_{w4}$$

$$\therefore t_{w4} = 21.8^\circ\text{C}$$

$$\therefore \text{Approach} = t_{w4} - t_{wb1} = 21.8 - 15.2 = 6.6^\circ\text{C}$$

$$\text{Range} = t_{w3} - t_{w4} = 30 - 21.8 = 8.2^\circ\text{C}$$

Fraction of water evaporated, $x = G(W_2 - W_1) = 1(0.0213 - 0.0088)$
 $= 0.0125 \text{ kg/kg dry air}$

Example 15.9 Water from a cooling system is itself to be cooled in a cooling tower at a rate of 2.78 kg/s. The water enters the tower at 65°C and leaves a collecting tank at the base at 38°C. Air flows through the tower, entering the base at 15°C, 0.1 MPa, 55% RH, and leaving the top at 35°C, 0.1 MPa, saturated. Make-up water enters the collecting tank at 14°C. Determine the air flow rate into the tower in m³/s and the make-up water flow rate in kg/s.

Solution Figure Ex. 15.9 shows the flow diagram of the cooling tower. From the steam tables.

at 15°C, $p_{\text{sat}} = 0.01705 \text{ bar}$, $h_g = 2528.9 \text{ kJ/kg}$

at 35°C, $p_{\text{sat}} = 0.05628 \text{ bar}$, $h_g = 2565.3 \text{ kJ/kg}$

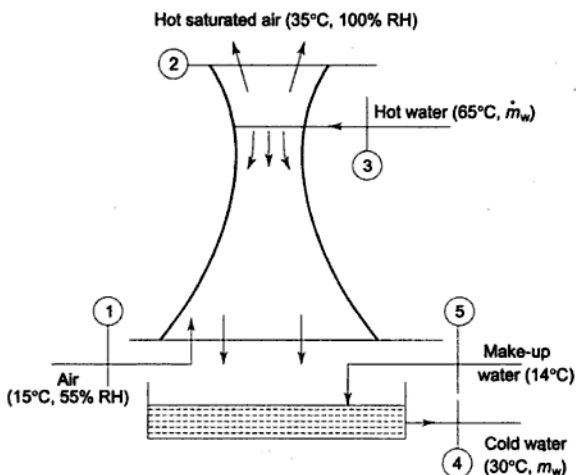

Fig. Ex. 15.9

$$\phi_1 = \frac{P_w}{(P_{\text{sat}})_{15^\circ\text{C}}} = 0.55$$

$$\therefore P_{w1} = 0.55 \times 0.01705 = 0.938 \times 10^{-2} \text{ bar}$$

$$\phi_2 = \frac{P_w}{(P_{\text{sat}})_{35^\circ\text{C}}} = 1.00$$

$$\therefore P_{w2} = 0.05628 \text{ bar}$$

$$W_1 = 0.622 \frac{P_w}{p - P_w} = 0.622 \times \frac{0.938 \times 10^{-2}}{1.00 - 0.00938}$$

$$= 0.00589 \text{ kg vap./kg dry air}$$

$$W_2 = 0.622 \times \frac{0.05628}{1.00 - 0.05628} = 0.0371 \text{ kg vap./dry air}$$

$$\therefore \text{Make-up water} = W_2 - W_1$$

$$= 0.0371 - 0.00589$$

$$= 0.03121 \text{ kg vap./kg dry air}$$

Energy balance gives

$$H_2 + H_4 - H_1 - H_3 - H_5 = 0$$

For 1 kg of dry air

$$c_{\text{pa}}(t_2 - t_1) + W_2 h_2 - W_1 h_1 + \dot{m}_w (h_4 - h_3) - (W_2 - W_1) h_5 = 0$$

$$\therefore 1.005(35 - 15) + 0.0371 \times 2565.3 - 0.00589 \times 2528.9$$

$$+ \dot{m}_w (-35) 4.187 - 0.03121 \times 4.187 \times 14 = 0$$

PROBLEMS

- 15.1 An air-water vapour mixture at 0.1 Mpa, 30°C, 80% RH has a volume of 50 m³. Calculate the specific humidity, dew point, wbt, mass of dry air, and mass of water vapour.
If the mixture is cooled at constant pressure to 5°C, calculate the amount of water vapour condensed.
- 15.2 A sling psychrometer reads 40°C dbt and 36°C wbt. Find the humidity ratio, relative humidity, dew point temperature, specific volume, and enthalpy of air.
- 15.3 Calculate the amount of heat removed per kg of dry air if the initial condition of air is 35°C, 70% RH, and the final condition is 25°C, 60% RH.
- 15.4 Two streams of air 25°C, 50% RH and 25°C, 60% RH are mixed adiabatically to obtain 0.3 kg/s of dry air at 30°C. Calculate the amounts of air drawn from both the streams and the humidity ratio of the mixed air.
- 15.5 Air at 40°C dbt and 27°C wbt is to be cooled and dehumidified by passing it over a refrigerant-filled coil to give a final condition of 15°C and 90% RH. Find the amounts of heat and moisture removed per kg of dry air.
- 15.6 An air-water vapour mixture enters a heater-humidifier unit at 5°C, 100 kPa, 50% RH. The flow rate of dry air is 0.1 kg/s. Liquid water at 10°C is sprayed into the mixture at the rate of 0.002 kg/s. The mixture leaves the unit at 30°C, 100 kPa. Calculate (a) the relative humidity at the outlet, and (b) the rate of heat transfer to the unit.
- 15.7 A laboratory has a volume of 470 m³, and is to be maintained at 20°C, 52.5% RH. The air in the room is to be completely changed once every hour and is drawn from the atmosphere at 1.05 bar, 32°C, 86% RH, by a fan absorbing 0.45 kW. This air passes through a cooler which reduces its temperature and causes condensation, the condensate being drained off at 8°C. The resulting saturated air is heated to room condition. The total pressure is constant throughout. Determine (a) the temperature of the air leaving the cooler, (b) the rate of condensation, (c) the heat transfer in the cooler, and (d) the heat transfer in the heater.

Ans. (a) 10°C, (b) 10.35 kg/h, (c) 11.33 kW, (d) 1.63 kW

- 15.8 In an air conditioning system, air is to be cooled and dehumidified by means of a cooling coil. The data are as follows:
Initial condition of the air at inlet to the cooling coil: dbt = 25°C, partial pressure of water vapour = 0.019 bar, absolute total pressure = 1.02 bar
Final condition of air at exit of the cooling coil:
dbt = 15°C, RH = 90%, absolute total pressure = 1.02 bar.
Other data are as follows:
Characteristic gas constant for air = 278 J/kg K
Characteristic gas constant for water vapour = 461.5 J/kg K
Saturation pressure for water at 15°C = 0.017 bar
Enthalpy of dry air = 1.005 t kJ/kg
Enthalpy of water vapour = (2500 + 1.88 t) kJ/kg where t is in °C
Determine (a) the moisture removed from air per kg of dry air, (b) the heat removed by the cooling coil per kg of dry air.

Ans. (a) 0.0023 kg/kg d.a. (b) 16.1 kJ/kg d.a.

- 15.9 Air at 30°C, 80% RH is cooled by spraying in water at 12°C. This causes saturation, followed by condensation, the mixing being assumed to take place adiabatically and the condensate being drained off at 16.7°C. The resulting saturated mixture is then heated to produce the required conditions of 60% RH at 25°C. The total pressure is constant at 101 kPa. Determine the mass of water supplied to the sprays to provide 10 m³/h of conditioned air. What is the heater power required?

Ans. 2224 kg/h, 2.75 kW

- 15.10 An air-conditioned room requires 30 m³/min of air at 1.013 bar, 20°C, 52.5% RH. The steady flow conditioner takes in air at 1.013 bar, 77% RH, which it cools to adjust the moisture content and reheats to room temperature. Find the temperature to which the air is cooled and the thermal loading on both the cooler and heater. Assume that a fan before the cooler absorbs 0.5 kW, and that the condensate is discharged at the temperature to which the air is cooled.

Ans. 10°C, 25 kW, 6.04 kW

- 15.11 An industrial process requires an atmosphere having a RH of 88.4% at 22°C, and involves a flow rate of 2000 m³/h. The external conditions are 44.4% RH, 15°C. The air intake is heated and then humidified by water spray at 20°C. Determine the mass flow rate of spray water and the power required for heating if the pressure throughout is 1 bar.

Ans. 23.4 kg/h, 20.5 kW

- 15.12 Cooling water enters a cooling tower at a rate of 1000 kg/h and 70°C. Water is pumped from the base of the tower at 24°C and some make-up water is added afterwards. Air enters the tower at 15°C, 50% RH, 1.013 bar, and is drawn from the tower saturated at 34°C, 1 bar. Calculate the flow rate of the dry air in kg/h and the make-up water required per hour.

Ans. 2088 kg/h, 62.9 kg/h

- 15.13 A grain dryer consists of a vertical cylindrical hopper through which hot air is blown. The air enters the base at 1.38 bar, 65°C, 50% RH. At the top, saturated air is discharged into the atmosphere at 1.035 bar, 60°C. Estimate the moisture picked up by 1 kg of dry air, and the total enthalpy change between the entering and leaving streams expressed per unit mass of dry air.

Ans. 0.0864 kJ/kg air, 220 kJ/kg air

- 15.14 Air enters a counterflow cooling tower at a rate of 100 m³/s at 30°C dbt and 40% relative humidity. Air leaves at the top of the tower at 32°C and 90% relative humidity. Water enters the tower at 35°C and the water flow rate is 1.2 times the mass flow rate of air. Make-up water is supplied at 20°C. What are the range and approach of the tower? At what rate is heat absorbed from the load by the stream of water on its way back to the top of the tower? What percentage of the water flow rate must be supplied as make-up water to replace the water evaporated into the air stream?

Ans. Range = 8.7°C, Approach = 6.3°C, $Q = 5005$ kW, % make-up = 1.39%

16

Reactive Systems

In this chapter we shall study the thermodynamics of mixtures that may be undergoing chemical reaction. With every chemical reaction is associated a chemical equation which is obtained by balancing the atoms of each of the atomic species involved in the reaction. The initial constituents which start the reaction are called the *reactants*, and the final constituents which are formed by chemical reaction with the rearrangement of the atoms and electrons are called the *products*. The reaction between the reactants, hydrogen and oxygen, to form the product water can be expressed as



The equation indicates that one mole of hydrogen and half a mole of oxygen combine to form one mole of water. The reaction can also proceed in the reverse direction. The coefficients 1, $\frac{1}{2}$, 1 in the chemical Eq. (16.1) are called *stoichiometric coefficients*.

16.1 Degree of Reaction

Let us suppose that we have a mixture of four substances, A_1 , A_2 , A_3 and A_4 , capable of undergoing a reaction of the type



where the ν 's are the stoichiometric coefficients.

Starting with arbitrary amounts of both initial and final constituents, let us imagine that the reaction proceeds completely to the right with the disappearance of at least one of the initial constituents, say, A_1 . Then the original number of moles of the initial constituents is given in the form

$$n_1 (\text{original}) = n_0 v_1$$

$$n_2 (\text{original}) = n_0 v_2 + N_2$$

where n_0 is an arbitrary positive number, and N_2 is the residue (or excess) of A_2 , i.e., the number of moles of A_2 which cannot combine. If the reaction is assumed to proceed completely to the left with the disappearance of the final constituent A_3 , then

$$n_3 (\text{original}) = n'_0 v_3$$

$$n_4 (\text{original}) = n'_0 v_4 + N_4$$

where n'_0 is an arbitrary positive number and N_4 is the excess number of moles of A_4 left after the reaction is complete from right to left.

For a reaction that has occurred completely to the left, there is a maximum amount possible of each initial constituent, and a minimum amount possible of each final constituent, so that

$$n_1 (\text{max}) = n_0 v_1 \quad + \quad n'_0 v_1$$

(Original number of moles of A_1) (Number of moles of A_1 formed
by chemical reaction)

$$(n'_0 v_3 A_3 + n'_0 v_4 A_4 \rightarrow n'_0 v_1 A_1 + n'_0 v_2 A_2)$$

$$= (n_0 + n'_0) v_1$$

$$n_2 (\text{max}) = (n_0 v_2 + N_2) \quad + \quad n'_0 v_2$$

(Original number of moles of A_2) (Number of moles of A_2 formed
by chemical reaction)

$$= (n_0 + n'_0) v_2 + N_2$$

$n_3 (\text{min}) = 0$ (The constituent A_3 completely disappears by reaction)

$n_4 (\text{min}) = N_4$ (The excess number of moles of A_4 that are left after the reaction is complete to the left)

Similarly, if the reaction is imagined to proceed completely to the right, there is a minimum amount of each initial constituent, and a maximum amount of each final constituent, so that

$$n_1 (\text{min}) = 0$$

$$n_2 (\text{min}) = N_2$$

$$n_3 (\text{max}) = n'_0 v_3 \quad + \quad n_0 v_3$$

(Original amount) (Amount formed by chemical reaction)

$$(n_0 v_1 A_1 + n_0 v_2 A_2 \rightarrow n_0 v_3 A_3 + n_0 v_4 A_4)$$

$$= (n_0 + n'_0) v_3$$

$$n_4 (\text{max}) = (n_0 + n'_0) v_4 + N_4$$

Let us suppose that the reaction proceeds partially either to the right or to the left to the extent that there are n_1 moles of A_1 , n_2 moles of A_2 , n_3 moles of A_3 , and n_4 moles of A_4 . The *degree* (or *advancement*) of reaction ε is defined in terms of any one of the initial constituents, say, A_1 , as the fraction

$$\varepsilon = \frac{n_1 (\text{max}) - n_1}{n_1 (\text{max}) - n_1 (\text{min})}$$

It is seen that when $n_1 = n_1$ (max), $\varepsilon = 0$, the reaction will start from left to right. When $n_1 = n_1$ (min), $\varepsilon = 1$, reaction is complete from left to right.

The degree of reaction can thus be written in the form

$$\varepsilon = \frac{(n_0 + n'_0)v_1 - n_1}{(n_0 + n'_0)v_1}$$

Therefore

$$\begin{aligned} n_1 &= (n_0 + n'_0)v_1 - (n_0 + n'_0)v_1\varepsilon \\ &= n \text{ (at start)} - n \text{ (consumed)} \\ &= \text{Number of moles of } A_1 \text{ at start} - \text{number of moles of } A_1 \\ &\quad \text{consumed in the reaction} \\ &= (n_0 + n'_0)v_1(1 - \varepsilon) \\ n_2 &= n \text{ (at start)} - n \text{ (consumed)} \\ &= (n_0 + n'_0)v_2 + N_2 - (n_0 + n'_0)v_2\varepsilon \\ &= (n_0 + n'_0)v_2(1 - \varepsilon) + N_2 \\ n_3 &= n \text{ (at start)} + n \text{ (formed)} \\ &= 0 + (n_0 + n'_0)v_3\varepsilon \\ &= (n_0 + n'_0)v_3\varepsilon \\ n_4 &= n \text{ (at start)} + n \text{ (formed)} \\ &= N_4 + (n_0 + n'_0)v_4\varepsilon \\ &= (n_0 + n'_0)v_4\varepsilon + N_4 \end{aligned} \tag{16.2}$$

The number of moles of the constituents change during a chemical reaction, not independently but restricted by the above relations. These equations are the *equations of constraint*. The n 's are functions of ε only. In a homogeneous system, in a given reaction, the mole fraction x 's are also functions of ε only, as illustrated below.

Let us take the reaction

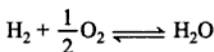

in which n_0 moles of hydrogen combine with $n_0/2$ moles of oxygen to form n_0 moles of water. The n 's and x 's as functions of ε are shown in the table given below.

A	v	n	x
$A_1 = \text{H}_2$	$v_1 = 1$	$n_1 = n_0(1 - \varepsilon)$	$x_1 = \frac{n_1}{\Sigma n} = \frac{2(1 - \varepsilon)}{3 - \varepsilon}$
$A_2 = \text{O}_2$	$v_2 = \frac{1}{2}$	$n_2 = \frac{n_0}{2}(1 - \varepsilon)$	$x_2 = \frac{1 - \varepsilon}{3 - \varepsilon}$
$A_3 = \text{H}_2\text{O}$	$v_3 = 1$	$n_3 = n_0\varepsilon$	$x_3 = \frac{2\varepsilon}{3 - \varepsilon}$
		$\Sigma n = \frac{n_0}{2}(3 - \varepsilon)$	

If the reaction is imagined to advance to an infinitesimal extent, the degree of reaction changes from ε to $\varepsilon + d\varepsilon$, and the various n 's will change by the amounts

$$dn_1 = -(n_0 + n'_0) v_1 d\varepsilon$$

$$dn_2 = -(n_0 + n'_0) v_2 d\varepsilon$$

$$dn_3 = (n_0 + n'_0) v_3 d\varepsilon$$

$$dn_4 = (n_0 + n'_0) v_4 d\varepsilon$$

or

$$\frac{dn_1}{-v_1} = \frac{dn_2}{-v_2} = \frac{dn_3}{v_3} = \frac{dn_4}{v_4} = (n_0 + n'_0) d\varepsilon$$

which shows that the dn 's are proportional to the v 's.

16.2 Reaction Equilibrium

Let us consider a homogeneous phase having arbitrary amounts of the constituents, A_1, A_2, A_3 and A_4 , capable of undergoing the reaction

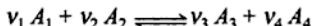

The phase is at uniform temperature T and pressure p . The Gibbs function of the mixture is

$$G = \mu_1 n_1 + \mu_2 n_2 + \mu_3 n_3 + \mu_4 n_4$$

where the n 's are the number of moles of the constituents at any moment, and the μ 's are the chemical potentials.

Let us imagine that the reaction is allowed to take place at constant T and p . The degree of reaction changes by an infinitesimal amount from ε to $\varepsilon + d\varepsilon$. The change in the Gibbs function is

$$\begin{aligned} dG_{T,p} &= \sum \mu_k dn_k \\ &= \mu_1 dn_1 + \mu_2 dn_2 + \mu_3 dn_3 + \mu_4 dn_4 \end{aligned}$$

The equations of constraint in differential form are

$$\begin{aligned} dn_1 &= -(n_0 + n'_0) v_1 d\varepsilon, & dn_3 &= (n_0 + n'_0) v_3 d\varepsilon \\ dn_2 &= -(n_0 + n'_0) v_2 d\varepsilon, & dn_4 &= (n_0 + n'_0) v_4 d\varepsilon \end{aligned}$$

On substitution

$$dG_{T,p} = (n_0 + n'_0) (-v_1\mu_1 - v_2\mu_2 + v_3\mu_3 + v_4\mu_4) d\varepsilon \quad (16.3)$$

When the reaction proceeds *spontaneously* to the right, $d\varepsilon$ is positive, and since $dG_{T,p} < 0$

$$(v_1\mu_1 + v_2\mu_2) > (v_3\mu_3 + v_4\mu_4)$$

If $\sum v_k \mu_k = (v_3\mu_3 + v_4\mu_4) - (v_1\mu_1 + v_2\mu_2)$, then it is negative for the reaction to the right.

When the reaction proceeds spontaneously to the left, $d\varepsilon$ is negative

$$(v_1\mu_1 + v_2\mu_2) < (v_3\mu_3 + v_4\mu_4)$$

i.e., $\sum v_k \mu_k$ is positive.

At equilibrium, the Gibbs function will be minimum, and

$$v_1\mu_1 + v_2\mu_2 = v_3\mu_3 + v_4\mu_4 \quad (16.4)$$

which is called the *equation of reaction equilibrium*.

Therefore, it is the value of $\sum v_k \mu_k$ which causes or forces the spontaneous reaction and is called the '*chemical affinity*'.

16.3 Law of Mass Action

For a homogeneous phase chemical reaction at constant temperature and pressure, when the constituents are *ideal gases*, the chemical potentials are given by the expressions of the type

$$\mu_k = \bar{R}T(\phi_k + \ln p + \ln x_k)$$

where the ϕ 's are functions of temperature only (Article 10.11).

Substituting in the equation of reaction equilibrium (16.4)

$$\begin{aligned} v_1(\phi_1 + \ln p + \ln x_1) + v_2(\phi_2 + \ln p + \ln x_2) \\ = v_3(\phi_3 + \ln p + \ln x_3) + v_4(\phi_4 + \ln p + \ln x_4) \end{aligned}$$

On rearranging

$$\begin{aligned} v_3 \ln x_3 + v_4 \ln x_4 - v_1 \ln x_1 - v_2 \ln x_2 + (v_3 + v_4 - v_1 - v_2) \ln p \\ = -(v_3 \phi_3 + v_4 \phi_4 - v_1 \phi_1 - v_2 \phi_2) \end{aligned}$$

$$\begin{aligned} \therefore \ln \frac{x_3^{v_3} \cdot x_4^{v_4}}{x_1^{v_1} \cdot x_2^{v_2}} p^{v_3 + v_4 - v_1 - v_2} \\ = -(v_3 \phi_3 + v_4 \phi_4 - v_1 \phi_1 - v_2 \phi_2) \end{aligned}$$

Denoting

$$\ln K = -(v_3 \phi_3 + v_4 \phi_4 - v_1 \phi_1 - v_2 \phi_2)$$

where K , known as the *equilibrium constant*, is a function of temperature only

$$\left[\frac{x_3^{v_3} \cdot x_4^{v_4}}{x_1^{v_1} \cdot x_2^{v_2}} \right]_{\epsilon=\epsilon_e} p^{v_3 + v_4 - v_1 - v_2} = K \quad (16.5)$$

This equation is called the *law of mass action*. K has the dimension of pressure raised to the $(v_3 + v_4 - v_1 - v_2)$ th power. Here the x 's are the values of mole fractions at equilibrium when the degree of reaction is ϵ_e .

The law of mass action can also be written in this form

$$\frac{p_3^{v_3} \cdot p_4^{v_4}}{p_1^{v_1} \cdot p_2^{v_2}} = K$$

where the p 's are the partial pressures.

16.4 Heat of Reaction

The equilibrium constant K is defined by the expression

$$\ln K = -(v_3 \phi_3 + v_4 \phi_4 - v_1 \phi_1 - v_2 \phi_2)$$

The equilibrium constant is given by

$$\ln K = \ln \left\{ \frac{x_3^{v_3} \cdot x_4^{v_4}}{x_1^{v_1} \cdot x_2^{v_2}} \right\}_{\epsilon_e} \cdot p^{v_3 + v_4 - v_1 - v_2}$$

$$\ln K = \frac{\frac{\epsilon_e}{1 + \epsilon_e} \cdot \frac{\epsilon_e}{1 + \epsilon_e}}{\frac{1 - \epsilon_e}{1 + \epsilon_e}} \cdot p^{v_3 + v_4 - v_1}$$

$$= \ln \frac{\epsilon_e^2}{1 - \epsilon_e^2} \cdot p$$

Since the three gases are monatomic, $c_p = \frac{5}{2} \bar{R}$ which, on being substituted in the Nernst's equation, gives

$$\ln \frac{\epsilon_e^2}{1 - \epsilon_e^2} \cdot p = -\frac{\Delta H_0}{RT} + \frac{5}{2} \ln T + \ln B \quad (16.9)$$

where

$$\frac{\Delta S_0}{\bar{R}} = \ln B$$

$$\ln \frac{\epsilon_e^2}{1 - \epsilon_e^2} \cdot \frac{p}{T^{5/2} \cdot B} = -\frac{\Delta H_0}{RT}$$

$$\therefore \frac{\epsilon_e^2}{1 - \epsilon_e^2} = B e^{-\Delta H_0/RT} \cdot \frac{T^{5/2}}{p} \quad (16.10)$$

where ϵ_e is the equilibrium value of the degree of ionization. This is known as the *Saha's equation*. For a particular gas the degree of ionization increases with an increase in temperature and a decrease in pressure.

It can be shown that ΔH_0 is the amount of energy necessary to ionize 1 gmol of atoms. If we denote the ionization potential ΔH_0 of the atom in volts by E , then

$$\Delta H_0 = E(\text{volts}) \times 1.59 \times 10^{-19} \frac{\text{coulomb}}{\text{electron}} \times 6.06 \times 10^{23} \frac{\text{electron}}{\text{g mol}}$$

$$= 9.6354 \times 10^4 E \text{ J/gmol}$$

Equation (16.9) becomes

$$\ln \frac{\epsilon_e}{1 - \epsilon_e} p = -\frac{96354 E}{RT} + \frac{5}{2} \ln T + \ln B \quad (16.11)$$

Expressing p in atmospheres, changing to common logarithms and introducing the value of B from statistical mechanics, Saha finally obtained the equation:

$$\log \frac{\epsilon_e^2}{1 - \epsilon_e^2} p (\text{atm}) = -\frac{96,354 E}{19,148 T} + \frac{5}{2} \log T + \log \frac{\omega_1 \omega_\epsilon}{\omega_a} - 6.491 \quad (16.12)$$

From this, the value of the degree of reaction at equilibrium ε_e may be calculated.

From Eq. (16.3), if $n_0 = 1$ and $n'_0 = 0$

$$\left(\frac{\partial G}{\partial \varepsilon}\right)_{T,p} = (v_3\mu_3 + v_4\mu_4 - v_1\mu_1 - v_2\mu_2)$$

Since $\mu_k = \bar{R}T(\phi_k + \ln p + \ln x_k)$

and $g_k = \bar{R}T(\phi_k + \ln p)$

so $\mu_k = g_k + \bar{P}T \ln x_k$

Therefore

$$\begin{aligned} \left(\frac{\partial G}{\partial \varepsilon}\right)_{T,p} &= v_3g_3 + v_4g_4 - v_1g_1 - v_2g_2 + \bar{R}T \ln \frac{x_3^{v_3} \cdot x_4^{v_4}}{x_1^{v_1} \cdot x_2^{v_2}} \\ &= \Delta G + \bar{R}T \ln \frac{x_3^{v_3} x_4^{v_4}}{x_1^{v_1} x_2^{v_2}} \end{aligned}$$

At $\varepsilon = 0, x_3 = 0, x_4 = 0$

$$\left(\frac{\partial G}{\partial \varepsilon}\right)_{T,p} = -\infty$$

and at $\varepsilon = 1, x_1 = 0, x_2 = 0$

$$\left(\frac{\partial G}{\partial \varepsilon}\right)_{T,p} = +\infty$$

At $\varepsilon = \frac{1}{2}, x_1 = \frac{v_1}{\Sigma v}, x_2 = \frac{v_2}{\Sigma v}$

$$x_3 = \frac{v_3}{\Sigma v}, x_4 = \frac{v_4}{\Sigma v}$$

where $\Sigma v = v_3 + v_4 + v_1 + v_2$

$$\left(\frac{\partial G}{\partial \varepsilon}\right)_{T,p}^{\varepsilon=\frac{1}{2}} = \Delta G + \bar{R}T \ln \frac{\left(\frac{v_3}{\Sigma v}\right)^{v_3} \left(\frac{v_4}{\Sigma v}\right)^{v_4}}{\left(\frac{v_1}{\Sigma v}\right)^{v_1} \left(\frac{v_2}{\Sigma v}\right)^{v_2}}$$

If $p = 1 \text{ atm.}, T = 298 \text{ K}$

$$\left(\frac{\partial G}{\partial \varepsilon}\right)_{T=298 \text{ K}}^{p=1 \text{ atm.}} = \Delta G^{\circ}_{298}$$

$\varepsilon = \frac{1}{2}$

because the magnitude of the second term on the right hand side of the equation is very small compared to ΔG° . The slope $\left(\frac{\partial G}{\partial \varepsilon}\right)_{T,p}$ at $\varepsilon = \frac{1}{2}$ is called the 'affinity'

of the reaction, and it is equal to ΔG° at the standard reference state. The magnitude of the slope at $\varepsilon = 1/2$ (Fig. 16.2) indicates the direction in which the reaction will proceed. For water vapour reaction, ΔG_{298}° is a large positive number, which indicates the equilibrium point is far to the left of $\varepsilon = 1/2$, and therefore, ε_e is very small. Again for the reaction $\text{NO} \rightleftharpoons \frac{1}{2}\text{N}_2 + \frac{1}{2}\text{O}_2$, ΔG_{298}° is a large negative value, which shows that the equilibrium point is far to the right of $\varepsilon = 1/2$, and so ε_e is close to unity.

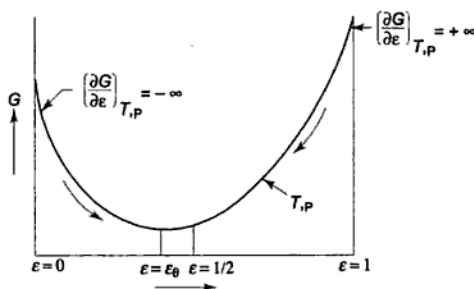

Fig. 16.2 Plot of G against ε at constants T and p

16.9 Fugacity and Activity

The differential of the Gibbs function of an ideal gas undergoing an isothermal process is

$$\begin{aligned} dG &= Vdp = \frac{n\bar{R}T}{p} dp \\ &= n\bar{R}T d(\ln p) \end{aligned}$$

Analogously, the differential of the Gibbs function for a real gas is

$$dG = n\bar{R}T d(\ln f) \quad (16.15)$$

where f is called the *fugacity*, first used by Lewis. The value of fugacity approaches the value of pressure as the latter tends to zero, i.e., when ideal gas conditions apply. Therefore

$$\lim_{p \rightarrow 0} \frac{f}{p} = 1$$

For an ideal gas $f=p$. Fugacity has the same dimension as pressure. Integrating Eq. (16.15)

$$G - G^0 = n\bar{R}T \ln \frac{f}{f^0}$$

Therefore, for endothermic reaction, when ΔH is positive, $\left(\frac{\partial \epsilon_e}{\partial T}\right)_p$ is positive, and for exothermic reaction, when ΔH is negative, $\left(\frac{\partial \epsilon_e}{\partial T}\right)_p$ is negative.

$$\begin{aligned} \text{Again, } \left(\frac{\partial \epsilon_e}{\partial p}\right)_T &= -\left(\frac{\partial \epsilon_e}{\partial \ln K}\right)_p \left(\frac{\partial \ln K}{\partial p}\right)_{\epsilon_e} \\ &= \frac{-\left(\frac{\partial \ln K}{\partial p}\right)_{\epsilon_e}}{\left(\frac{\partial \ln K}{\partial \epsilon_e}\right)_p} \end{aligned}$$

Using the law of mass action

$$\left(\frac{\partial \epsilon_e}{\partial p}\right)_T = -\frac{v_3 + v_4 - v_1 - v_2}{p \frac{d}{d\epsilon_e} \ln \left[\frac{x_3^{v_3} \cdot x_4^{v_4}}{x_1^{v_1} \cdot x_2^{v_2}} \right]_{\epsilon = \epsilon_e}} \quad (16.18)$$

If $(v_3 + v_4) > (v_1 + v_2)$, i.e., the number of moles increase or the volume increases due to reaction, $\left(\frac{\partial \epsilon_e}{\partial p}\right)_T$ is negative. If $(v_3 + v_4) < (v_1 + v_2)$, i.e., volume decreases in an isothermal reaction, $\left(\frac{\partial \epsilon_e}{\partial p}\right)_T$ is positive.

16.11 Heat Capacity of Reacting Gases in Equilibrium

For a reaction of four ideal gases, such as



the enthalpy of mixture at equilibrium is

$$H = \sum n_k h_k$$

where $n_1 = (n_0 + n'_0) v_1 (1 - \epsilon_e)$, $n_2 = (n_0 + n'_0) v_2 (1 - \epsilon_e) + N_2$

$$n_3 = (n_0 + n'_0) v_3 \epsilon_e, \text{ and } n_4 = (n_0 + n'_0) v_4 \epsilon_e + N_4$$

Let us suppose that an infinitesimal change in temperature takes place at constant pressure in such a way that equilibrium is maintained.

ϵ_e will change to the value $\epsilon_e + d\epsilon_e$, and the enthalpy will change by the amount

$$dH_p = \sum n_k dh_k + \sum h_k dn_k$$

where

$$dh_k = c_{pk} dT, \quad dn_k = \pm (n_0 + n'_0) v_k d\epsilon_e$$

Therefore

$$dH_p = \sum n_k c_{pk} dT + (n_0 + n'_0) (v_3 h_3 + v_4 h_4 - v_1 h_1 - v_2 h_2) d\epsilon_e$$

The heat capacity of the reacting gas mixture is

$$C_p = \left(\frac{\partial H}{\partial T} \right)_p = \sum n_k c_{pk} + (n_0 + n'_0) \Delta H \left(\frac{\partial \epsilon_e}{\partial T} \right)_p$$

Using Eq. (16.14)

$$C_p = \sum n_k c_{pk} + (n_0 + n'_0) \frac{(\Delta H)^2}{\bar{R}T^2 \frac{d}{d\epsilon} \ln \left[\frac{x_3^{v_1} \cdot x_4^{v_2}}{x_1^{v_1} \cdot x_2^{v_2}} \right]_{\epsilon = \epsilon_e}} \quad (16.19)$$

16.12 Combustion

Combustion is a chemical reaction between a fuel and oxygen which proceeds at a fast rate with the release of energy in the form of heat. In the combustion of methane, e.g.

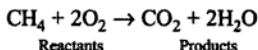

One mole of methane reacts with 2 moles of oxygen to form 1 mole of carbon dioxide and 2 moles of water. The water may be in the liquid or vapour state depending on the temperature and pressure of the products of combustion. Only the initial and final products are being considered without any concern for the intermediate products that usually occur in a reaction.

Atmospheric air contains 21% oxygen, 78% nitrogen, and 1% argon by volume. In combustion calculations, however, the argon is usually neglected, and air is assumed to consist of 21% oxygen and 79% nitrogen by volume (or molar basis). On a mass basis, air contains 23% oxygen and 77% nitrogen.

For each mole of oxygen taking part in a combustion reaction, there are 79.0/21.0 = 3.76 moles of nitrogen. So far the combustion of methane, the reaction can be written as

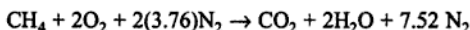

The minimum amount of air which provides sufficient oxygen for the complete combustion of all the elements like carbon, hydrogen, etc., which may oxidize is called the *theoretical or stoichiometric air*. There is no oxygen in the products when complete combustion (oxidation) is achieved with this theoretical air. In practice, however, more air than this theoretical amount is required to be supplied for complete combustion. Actual air supplied is usually expressed in terms of percent theoretical air; 150% theoretical air means that 1.5 times the theoretical air is supplied. Thus, with 150% theoretical air, the methane combustion reaction can be written as

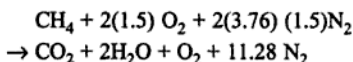

Another way of expressing the actual air quantity supplied is in terms of excess air. Thus 150% theoretical air means 50% excess air.

16.15 Adiabatic Flame Temperature

If a combustion process occurs adiabatically in the absence of work transfer or changes in K.E. and P.E., then the energy equation becomes

$$H_R = H_P$$

or

$$\sum_R n_i \bar{h}_i = \sum_P n_c \bar{h}_c$$

or

$$\sum_R n_i [\bar{h}_i^0 + \Delta \bar{h}]_i = \sum_P n_c [\bar{h}_c^0 + \Delta \bar{h}]_c \quad (16.23)$$

For such a process, the temperature of the products is called the *adiabatic flame temperature* which is the maximum temperature achieved for the given reactants. The adiabatic flame temperature can be controlled by the amount of excess air supplied; it is the maximum with a stoichiometric mixture. Since the maximum permissible temperature in a gas turbine is fixed from metallurgical considerations, close control of the temperature of the products is achieved by controlling the excess air.

For a given reaction the adiabatic flame temperature is computed by trial and error. The energy of the reactants H_R being known, a suitable temperature is chosen for the products so that the energy of the products at that temperature becomes equal to the energy of the reactants.

16.16 Enthalpy and Internal Energy of Combustion: Heating Value

The *enthalpy of combustion* is defined as the difference between the enthalpy of the products and the enthalpy of the reactants when complete combustion occurs at a given temperature and pressure.

Therefore

$$\bar{h}_{RP} = H_P - H_R$$

or

$$\bar{h}_{RP} = \sum_P n_c [\bar{h}_c^0 + \Delta \bar{h}]_c - \sum_R n_i [\bar{h}_i^0 + \Delta \bar{h}]_i \quad (16.24)$$

where \bar{h}_{RP} is the enthalpy of combustion (kJ/kg or kJ/kgmol) of the fuel.

The values of the enthalpy of combustion of different hydrocarbon fuels at 25°C, 1 atm. are given in Table 16.4.

The *internal energy of combustion*, u_{RP} , is defined in a similar way.

$$\bar{u}_{RP} = U_P - U_R$$

$$= \sum_P n_c [\bar{h}_c^0 + \Delta \bar{h} - p\bar{v}]_c - \sum_R n_i [\bar{h}_i^0 + \Delta \bar{h} - p\bar{v}]_i$$

If all the gaseous constituents are considered ideal gases and the volume of liquid and solid considered is assumed to be negligible compared to gaseous volume

$$\bar{u}_{RP} = \bar{u}_{RP} - \bar{R}T (n_{\text{gaseous products}} - n_{\text{gaseous reactants}}) \quad (16.25)$$

In the case of a constant pressure or steady flow process, the negative of the enthalpy of combustion is frequently called the *heating value at constant pressure*, which represents the heat transferred from the chamber during combustion at constant pressure.

Similarly, the negative of the internal energy of combustion is sometimes designated as the *heating value at constant volume* in the case of combustion, because it represents the amount of heat transfer in the constant volume process.

The *higher heating value* (HHV) or higher calorific value (HCV) is the heat transferred when H_2O in the products is in the liquid state. The *lower heating value* (LHV) or lower calorific value (LCV) is the heat transferred in the reaction when H_2O in the products is in the vapour state.

Therefore

$$\text{LHV} = \text{HHV} - m_{\text{H}_2\text{O}} \cdot h_{fg}$$

where $m_{\text{H}_2\text{O}}$ is the mass of water formed in the reaction.

16.17 Absolute Entropy and the Third Law of Thermodynamics

So far only the first law aspects of chemical reactions have been discussed. The second law analysis of chemical reactions needs a base for the entropy of various substances. The entropy of substances at the absolute zero of temperature, called absolute entropy, is dealt with by the third law of thermodynamics formulated in the early twentieth century primarily by W.H. Nernst (1864–1941) and Max Planck (1858–1947). The third law states that the entropy of a perfect crystal is zero at the absolute zero of temperature and it represents the maximum degree of order. A substance not having a perfect crystalline structure and possessing a degree of randomness such as a solid solution or a glassy solid, has a finite value of entropy at absolute zero. The third law (see Chapter 11) provides an absolute base from which the entropy of each substance can be measured. The entropy relative to this base is referred to as the absolute entropy. Table 16.3 gives the absolute entropy of various substances at the standard state 25°C , 1 atm. For any other state

$$\bar{s}_{T,p} = \bar{s}_T^0 + (\Delta\bar{s})_{T,1\text{ atm}, \rightarrow T,p}$$

where \bar{s}_T^0 refers to the absolute entropy at 1 atm. and temperature T , and $(\Delta\bar{s})_{T,1\text{ atm}, \rightarrow T,p}$ refers to the change of entropy for an isothermal change of pressure from 1 atm. to pressure p (Fig. 16.6). Table C in the appendix gives the values of \bar{s}^0 for various substances at 1 atm. and at different temperatures. Assuming ideal gas behaviour $(\Delta\bar{s})_{T,1\text{ atm}, \rightarrow T,p}$ can be determined (Fig. 16.6)

$$\bar{s}_2 - \bar{s}_1 = -\bar{R} \ln \frac{p_2}{p_1}$$

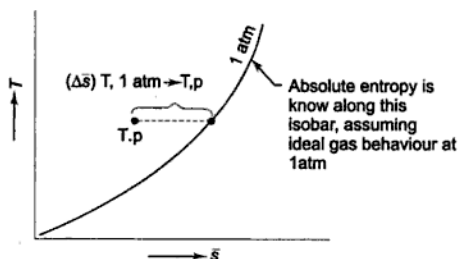

Fig. 16.6 Absolute entropy

16.18 Second Law Analysis of Reactive Systems

The reversible work for a steady state steady flow process, in the absence of changes in K.E. and P.E., is given by

$$W_{\text{rev}} = \sum n_i (h_i - T_0 s_i) - \sum n_e (h_e - T_0 s_e)$$

For an S.S.S.F. process involving a chemical reaction

$$W_{\text{rev}} = \sum_R n_i [\bar{h}_i^0 + \Delta \bar{h} - T_0 \bar{s}_i] - \sum_P n_e [\bar{h}_e^0 + \Delta \bar{h} - T_0 \bar{s}_e] \quad (16.26)$$

The irreversibility for such a process is

$$I = \sum_P n_e T_0 \bar{s}_e - \sum_R n_i T_0 \bar{s}_i - Q_{\text{C.V.}}$$

The availability, ψ , in the absence of K.E. and P.E. changes, for an S.S.S.F. process is

$$\psi = (h - T_0 s) - (h_0 - T_0 s_0)$$

When an S.S.S.F. chemical reaction takes place in such a way that both the reactants and products are in temperature equilibrium with the surroundings, the reversible work is given by

$$W_{\text{rev}} = \sum_R n_i \bar{g}_i - \sum_P n_e \bar{g}_e \quad (16.27)$$

where the $\bar{g}'s$ refer to the Gibbs function. The Gibbs function for formation, \bar{g}_f^0 , is defined similar to enthalpy of formation, \bar{h}_f^0 . The Gibbs function of each of the elements at 25°C and 1 atm. pressure is assumed to be zero, and the Gibbs function of each substance is found relative to this base. Table 16.1 gives \bar{g}_f^0 for some substances at 25°C, 1 atm.

16.19 Chemical Exergy

In Chapter 8, it was stated that when a system is at the dead state, it is in thermal and mechanical equilibrium with the environment, and the value of its exergy is zero. To state it more precisely, the *thermomechanical* contribution to exergy is zero. However, the contents of a system at the dead state may undergo chemical reaction with environmental components and produce additional work. We will here study a combined system formed by an environment and a system having a certain amount of fuel at T_0, p_0 . The work obtainable by allowing the fuel to react with oxygen from the environment to produce the environmental components of CO_2 and H_2O is evaluated. The *chemical exergy* is thus defined as the maximum theoretical work that could be developed by the combined system. Thus for a given system at a specific state:

$$\text{Total exergy} = \text{Thermomechanical exergy} + \text{Chemical exergy}$$

Let us consider a hydrocarbon fuel (C_aH_b) at T_0, p_0 reacting with oxygen from the environment (Fig. 16.7) which is assumed to be consisting of an ideal gas mixture at T_0, p_0 . The oxygen that reacts with the fuel is at a partial pressure of x_{O_2}

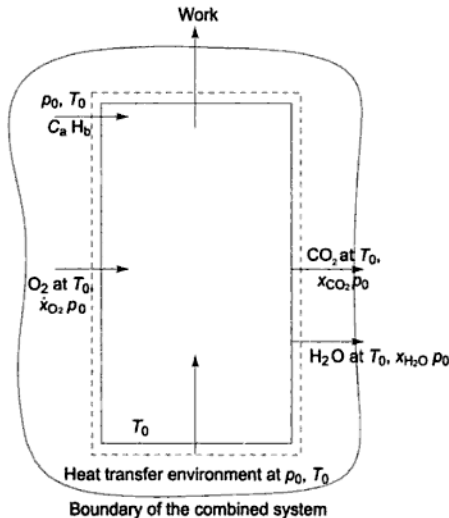

Fig. 16.7 Fuel exergy concept

p_0 , where x_{O_2} is the mole fraction of oxygen in the environment. The fuel and oxygen react completely to produce CO_2 and H_2O , which exit in separate streams at T_0 and respective partial pressures of $x_{\text{CO}_2} \cdot p_0$ and $x_{\text{H}_2\text{O}} \cdot p_0$. The reaction is given by:

where the first term on the right is the absolute entropy at T_0 and p_0 , and x_i is the mole fraction of component i in the environment. Therefore, Eq. (16.31) becomes,

$$\begin{aligned} \bar{a}_{\text{ch}} = & \left[\bar{h}_{\text{C}_a\text{H}_b} + \left(a + \frac{b}{4} \right) \bar{h}_{\text{O}_2} - a \bar{h}_{\text{CO}_2} - \frac{b}{2} \bar{h}_{\text{H}_2\text{O}} \right] (\text{at } T_0, p_0) \\ & - T_0 \left[\bar{s}_{\text{C}_a\text{H}_b} + \left(a + \frac{b}{4} \right) \bar{s}_{\text{O}_2} - a \bar{s}_{\text{CO}_2} - \frac{b}{2} \bar{s}_{\text{H}_2\text{O}} \right] (\text{at } T_0, p_0) \\ & + RT_0 \ln \frac{(x_{\text{O}_2})^{a+b/4}}{(x_{\text{CO}_2})^a (x_{\text{H}_2\text{O}})^{b/2}} \end{aligned} \quad (16.33)$$

In terms of Gibbs functions of respective substances,

$$\begin{aligned} \bar{a}_{\text{ch}} = & \left[\bar{g}_{\text{C}_a\text{H}_b} + \left(a + \frac{b}{4} \right) \bar{g}_{\text{O}_2} - a \bar{g}_{\text{CO}_2} - \frac{b}{2} \bar{g}_{\text{H}_2\text{O}} \right] (\text{at } T_0, p_0) \\ & + \bar{R} T_0 \ln \frac{(x_{\text{O}_2})^{a+b/4}}{(x_{\text{CO}_2})^a (x_{\text{H}_2\text{O}})^{b/2}} \end{aligned} \quad (16.34)$$

where $\bar{g}(T_0, p_0) = \bar{g}_f^0 + \Delta \bar{g}_{T_0, p_0 \rightarrow T_{\text{ref}}, p_{\text{ref}}}$

For the special case when T_0 and p_0 are the same as T_{ref} and p_{ref} , $\Delta \bar{g}$ will be zero.

The chemical exergy of pure CO at T_0, p_0 where the reaction is given by:

$$\begin{aligned} \text{CO} + \frac{1}{2} \text{O}_2 & \longrightarrow \text{CO}_2 \\ (\bar{a}_{\text{ch}})_{\text{CO}} = & \left[\bar{g}_{\text{CO}} + \frac{1}{2} \bar{g}_{\text{O}_2} - \bar{g}_{\text{CO}_2} \right] (\text{at } T_0, p_0) \\ & + \bar{R} T_0 \ln \frac{(x_{\text{O}_2})^{1/2}}{x_{\text{CO}_2}} \end{aligned}$$

Water is present as a vapour within the environment, but normally is a liquid at T_0, p_0 . The chemical exergy of liquid water is

$$\begin{aligned} \text{H}_2\text{O}(1) & \longrightarrow \text{H}_2\text{O}(g) \\ (\bar{a}_{\text{ch}})_{\text{H}_2\text{O}(1)} = & \left[\bar{g}_{\text{H}_2\text{O}(1)} - \bar{g}_{\text{H}_2\text{O}(g)} \right] (\text{at } T_0, p_0) \\ & + \bar{R} T_0 \ln \frac{1}{x_{\text{H}_2\text{O}(g)}} \end{aligned}$$

The specific exergy of a system is

$$\begin{aligned} a = & a_{\text{thermo-mech}} + a_{\text{chem}} \\ = & (u - u_0) + p_0(v - v_0) - T_0(s - s_0) + \frac{V^2}{2} + gz + a_{\text{ch}} \end{aligned} \quad (16.35)$$

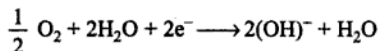

The electrolyte separating the electrodes transports the OH^- ions, completing the circuit, and the water (product) is removed from the cell. The overall reaction is:

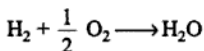

which is the same as the equation for the highly exothermic combustion reaction. However, in a fuel cell, only a relatively small amount of heat transfer between the cell and its surroundings takes place, and the temperature rise is also relatively much smaller.

Energy is removed from the fuel cell as electrical energy, whereas energy is removed from a combustion reaction as heat or as heat and work together. Because the fuel cell operates almost isothermally and continuously, the extent of its conversion of chemical energy to electrical energy is not limited by second law of thermodynamics.

In a fuel cell, there is a continuous supply of the reactants. The overall reaction, as stated, is divided into two reactions that occur on separate electrodes. The fuel and the oxidizer do not come directly into contact with each other, because direct contact would generally involve a non-isothermal (exothermic) reaction as in a normal combustion process.

One reaction, occurring on the surface of one electrode, ionizes the fuel and sends released electrons into an external electric circuit. On the surface of the other electrode, a reaction occurs that accepts electrons from the external circuit and when combined with the oxidizer creates ions. The ions from each reaction are combined in the electrolyte to complete the overall reaction. The electrolyte between the electrodes is necessary to transport ions, and it is not electrically conductive, thus, not allowing the flow of electrons through it.

The maximum work obtainable in a fuel cell is given by Eq. (16.27),

$$W_{\max} = -\Delta G = \sum_R n_i \bar{g}_i - \sum_P n_e \bar{g}_e$$

where $\bar{g} = g_f^0 + \Delta \bar{g}$

Also, from Eq. (16.2),

$$\begin{aligned} W_{\max} = W_{\text{rev}} &= \sum_R n_i [\bar{h}_f^0 + \Delta \bar{h} - T_0 \bar{s}]_i \\ &\quad - \sum_P n_e [\bar{h}_f^0 + \Delta \bar{h} - T_0 \bar{s}]_e \\ &= \Delta H - T_0 \left[\sum_R n_i \bar{s}_i - \sum_P n_e \bar{s}_e \right] \end{aligned}$$

The fuel cell efficiency is defined as:

$$\varepsilon = \Delta G / \Delta H \quad (16.38)$$

$$= -\bar{R}T \ln K = -8.3143 \times 1200 \ln 1.62$$

$$= -4813.2 \text{ J/gmol}$$

Example 16.4 Prove that for a mixture of reacting ideal gases,

$$\frac{d}{d\varepsilon} \ln \frac{x_3^{v_3} x_4^{v_4}}{x_1^{v_1} x_2^{v_2}} = \frac{(n_0 + n'_0)}{\sum n_k} \frac{(v_1 + v_2)(v_3 + v_4)}{\varepsilon(1 - \varepsilon)}$$

which is always positive.

Solution From the law of mass action, the equilibrium constant is given by:

$$K = \frac{x_3^{v_3} x_4^{v_4}}{x_1^{v_1} x_2^{v_2}} p^{v_3 + v_4 - v_1 - v_2}$$

$$= \frac{[n_3/\Sigma n]^{v_3} [n_4/\Sigma n]^{v_4}}{[n_1/\Sigma n]^{v_1} [n_2/\Sigma n]^{v_2}} p^{v_3 + v_4 - v_1 - v_2}$$

$$= \frac{n_3^{v_3} n_4^{v_4}}{n_1^{v_1} n_2^{v_2}} [p/\Sigma n]^{\Delta v}$$

where $\Sigma n = n_1 + n_2 + n_3 + n_4$ and $\Delta v = v_3 + v_4 - v_1 - v_2$.

By logarithmic differentiation,

$$\frac{dK}{K} - \Delta v \frac{dp}{p} + \Delta v \frac{d\Sigma n}{\Sigma n} = v_3 \frac{dn_3}{n_3} + v_4 \frac{dn_4}{n_4} - v_1 \frac{dn_1}{n_1} - v_2 \frac{dn_2}{n_2} \quad (1)$$

Now,

$$n_1 = (n_0 + n'_0) v_1 (1 - \varepsilon)$$

$$n_2 = (n_0 + n'_0) v_2 (1 - \varepsilon)$$

$$n_3 = (n_0 + n'_0) v_3 \varepsilon$$

$$n_4 = (n_0 + n'_0) v_4 \varepsilon$$

$$\Sigma n = (n_0 + n'_0) (v_1 + v_2 + \varepsilon \Delta v) \quad (2)$$

Again,

$$-\frac{dn_1}{v_1} = -\frac{dn_2}{v_2} = \frac{dn_3}{v_3} = \frac{dn_4}{v_4} = (n_0 + n'_0) d\varepsilon$$

$$d\Sigma n = dn_1 + dn_2 + dn_3 + dn_4 = (n_0 + n'_0) \Delta v d\varepsilon \quad (3)$$

From Eqs (1), (2) and (3),

$$\frac{dK}{K} - \Delta v \frac{dp}{p} + \Delta v (n_0 + n'_0) \Delta v d\varepsilon$$

$$= v_3 \frac{(n_0 + n'_0) v_3 d\varepsilon}{n_3} + v_4 \frac{(n_0 + n'_0) v_4 d\varepsilon}{n_4}$$

$$- v_1 \frac{(n_0 + n'_0) v_1 d\varepsilon}{n_1} - v_2 \frac{-(n_0 + n'_0) v_2 d\varepsilon}{n_2}$$

$$\frac{dK}{K} - \Delta v \frac{dp}{p} = (n_0 + n'_0) \left[\frac{v_3^2}{n_3} + \frac{v_4^2}{n_4} + \frac{v_1^2}{n_1} + \frac{v_2^2}{n_2} - \frac{(\Delta v)^2}{\Sigma n} \right] d\varepsilon$$

$$\therefore \frac{d}{d\varepsilon} \ln \left[\frac{x_3^{v_3} x_4^{v_4}}{x_1^{v_1} x_2^{v_2}} \right]_{\varepsilon=\varepsilon_e} = \frac{(n_0 + n'_0) \cdot (v_1 + v_2)(v_3 + v_4)}{\sum n_K \cdot \varepsilon(1 - \varepsilon)} \quad \text{Proved.}$$

Example 16.5 Starting with v_1 moles of A_1 and v_2 moles of A_2 , show that:

(a) At any value of ε ,

$$G = \varepsilon [v_3\mu_3 + v_4\mu_4 - v_1\mu_1 - v_2\mu_2] + v_1\mu_1 + v_2\mu_2$$

(b) At equilibrium,

$$G(\text{min}) = v_1\mu_{1e} + v_2\mu_{2e}$$

where the subscript e denotes an equilibrium value.

$$(c) \frac{G - G(\text{min})}{\bar{R}T} = \varepsilon \left[\ln \frac{x_3^{v_3} x_4^{v_4}}{x_1^{v_1} x_2^{v_2}} - \ln \frac{x_{3e}^{v_3} x_{4e}^{v_4}}{x_{1e}^{v_1} x_{2e}^{v_2}} \right]$$

(d) At $\varepsilon = 0$,

$$\frac{G - G(\text{min})}{\bar{R}T} = \ln \left[\frac{v_1}{v_1 + v_2} \right]^{v_1} \left[\frac{v_2}{v_1 + v_2} \right]^{v_2} - \ln x_{1e}^{v_1} x_{2e}^{v_2}$$

(e) At $\varepsilon = 1$,

$$\frac{G - G(\text{min})}{\bar{R}T} = \ln \left[\frac{v_3}{v_3 + v_4} \right]^{v_3} \left[\frac{v_4}{v_3 + v_4} \right]^{v_4} - \ln x_{3e}^{v_3} x_{4e}^{v_4}$$

Solution

(a)

$$G_{T,p} = \mu_1 n_1 + \mu_2 n_2 + \mu_3 n_3 + \mu_4 n_4$$

where,

$$n_1 = v_1(1 - \varepsilon), \quad n_2 = v_2(1 - \varepsilon), \quad n_3 = v_3\varepsilon \quad \text{and} \quad n_4 = v_4\varepsilon.$$

$$G_{T,p} = \mu_1 v_1 (1 - \varepsilon) + \mu_2 v_2 (1 - \varepsilon) + \mu_3 v_3 \varepsilon + \mu_4 v_4 \varepsilon$$

$$= \varepsilon [v_3\mu_3 + v_4\mu_4 - v_1\mu_1 - v_2\mu_2]$$

$$+ v_1\mu_1 + v_2\mu_2$$

Proved.

$$(b) \text{ At equilibrium, } \left[\frac{\partial G}{\partial \varepsilon} \right]_{T,p} = 0$$

$$G = \varepsilon [v_3\mu_3 + v_4\mu_4 - v_1\mu_1 - v_2\mu_2] + v_1\mu_1 + v_2\mu_2$$

$$\left[\frac{\partial G}{\partial \varepsilon} \right]_{T,p} = v_3\mu_3 + v_4\mu_4 - v_1\mu_1 - v_2\mu_2 = 0.$$

$$G(\text{min}) = v_1\mu_{1e} + v_2\mu_{2e}$$

Proved.

(c) We have from (a) and (b),

$$G - G(\text{min}) = [v_3\mu_3 + v_4\mu_4 - v_1\mu_1 - v_2\mu_2] + v_1\mu_1 + v_2\mu_2 - v_1\mu_{1e} - v_2\mu_{2e}$$

For an ideal gas,

$$\mu_k = \bar{R}T [\phi_k + \ln p + \ln x_k]$$

$$\begin{aligned}
 G - G(\min) &= \bar{R}T\epsilon \left[v_3\phi_3 + v_4\phi_4 - v_1\phi_1 - v_2\phi_2 + \ln p^{v_3 + v_4 - v_1 - v_2} \right. \\
 &\quad \left. + \ln \frac{x_3^{v_3} x_4^{v_4}}{x_1^{v_1} x_2^{v_2}} \right] \\
 &\quad + v_1 \bar{R}T (\phi_1 + \ln p + \ln x_1) \\
 &\quad + v_2 \bar{R}T (\phi_2 + \ln p + \ln x_2) \\
 &\quad - v_1 \bar{R}T (\phi_1 + \ln p + \ln x_{1e}) \\
 &\quad - v_2 \bar{R}T (\phi_2 + \ln p + \ln x_{2e}) \\
 &= \bar{R}T\epsilon \left[-\ln k + \ln p^{v_3 + v_4 - v_1 - v_2} + \ln \frac{x_3^{v_3} x_4^{v_4}}{x_1^{v_1} x_2^{v_2}} \right] \\
 &\quad + \bar{R}T \ln x_1^{v_1} + \bar{R}T \ln x_2^{v_2} - \bar{R}T \ln x_{1e}^{v_1} - \bar{R}T \ln x_{2e}^{v_2} \\
 &= \bar{R}T \left[-\ln \frac{x_{3e}^{v_3} x_{4e}^{v_4}}{x_{1e}^{v_1} x_{2e}^{v_2}} + \ln \frac{x_3^{v_3} x_4^{v_4}}{x_1^{v_1} x_2^{v_2}} + \ln x_1^{v_1} x_2^{v_2} - \ln x_{1e}^{v_1} x_{2e}^{v_2} \right] \\
 \frac{G - G(\min)}{\bar{R}T} &= \epsilon \left[\ln \frac{x_3^{v_3} x_4^{v_4}}{x_1^{v_1} x_2^{v_2}} - \ln \frac{x_{3e}^{v_3} x_{4e}^{v_4}}{x_{1e}^{v_1} x_{2e}^{v_2}} \right. \\
 &\quad \left. + \ln x_1^{v_1} x_2^{v_2} - \ln x_{1e}^{v_1} x_{2e}^{v_2} \right]
 \end{aligned}$$

Proved.

(d) At $\epsilon = 0$,

$$n_1 = v_1(1 - \epsilon) = v_1, \quad n_2 = v_2(1 - \epsilon) = v_2,$$

$$n_3 = v_3\epsilon = 0, \quad n_4 = v_4\epsilon = 0.$$

$$x_1 = \frac{n_1}{n_1 + n_2} = \frac{v_1}{v_1 + v_2}, \quad x_2 = \frac{v_2}{v_1 + v_2}$$

Substituting $\epsilon = 0$, Eq. of (c) reduces to

$$\begin{aligned}
 \frac{G_0 - G(\min)}{\bar{R}T} &= \ln x_1^{v_1} x_2^{v_2} - \ln x_{1e}^{v_1} x_{2e}^{v_2} \\
 &= \ln \left[\frac{v_1}{v_1 + v_2} \right]^{v_1} \left[\frac{v_2}{v_1 + v_2} \right]^{v_2} - \ln x_{1e}^{v_1} x_{2e}^{v_2} \quad \text{Proved.}
 \end{aligned}$$

(e) At $\epsilon = 1$, Eq. (c) reduces to

$$\begin{aligned}
 \frac{G_1 - G(\min)}{\bar{R}T} &= \ln \frac{x_3^{v_3} x_4^{v_4}}{x_1^{v_1} x_2^{v_2}} - \ln \frac{x_{3e}^{v_3} x_{4e}^{v_4}}{x_{1e}^{v_1} x_{2e}^{v_2}} + \ln x_1^{v_1} x_2^{v_2} - \ln x_{1e}^{v_1} x_{2e}^{v_2} \\
 &= \ln x_3^{v_3} x_4^{v_4} - \ln x_{3e}^{v_3} x_{4e}^{v_4}
 \end{aligned}$$

Again, $x_3 = \frac{V_3}{V_3 + V_4}$ and $x_4 = \frac{V_4}{V_3 + V_4}$, since $n_1 = 0$ and $n_2 = 0$
 at $\epsilon = 1$.

$$\frac{G_1 - G(\text{min})}{\bar{R}T} = \ln \left[\frac{V_3}{V_3 + V_4} \right]^{V_3} \left[\frac{V_4}{V_3 + V_4} \right]^{V_4} - \ln x_3^{V_3} \cdot x_4^{V_4} \quad \text{Proved.}$$

Example 16.6 For the dissociation of nitrogen tetroxide according to the equation

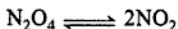

Show that the degree of dissociation at equilibrium is

$$e = \frac{V_e}{V_0} - 1$$

where V_0 = initial volume and V_e volume at equilibrium. At 50°C and 0.124 atm, there is a 77.7% increase in volume when equilibrium is reached. Find the value of the equilibrium constant.

Solution



Starting with n_0 moles of N_2O_4 at temperature T and pressure p , the initial volume V_0 is

$$V_0 = n_0 \frac{\bar{R}T}{p}$$

If V_e denotes the volume at equilibrium, the temperature and pressure remaining the same, then

$$V_e = [n_0(1 - \epsilon_e) + 2n_0\epsilon_e] \frac{\bar{R}T}{p}$$

where ϵ_e is the value of the degree of dissociation at equilibrium. This can be written:

$$V_e = (1 + \epsilon_e)V_0$$

or, $\epsilon_e = \frac{V_e}{V_0} - 1$ Proved.

Given $V_e/V_0 = 1.777$, $\epsilon_e = 0.777$.

Now, $n_1 = n_0 v_1(1 - \epsilon_e) = n_0(1 - \epsilon_e)$

$$n_3 = n_0 v_3, \quad \epsilon_e = n_0 \cdot 2\epsilon_e$$

$$\Sigma n = n_0(1 + \epsilon_e)$$

$$x_1 = \frac{1 - \epsilon_e}{1 + \epsilon_e}, \quad x_3 = \frac{2\epsilon_e}{1 + \epsilon_e}$$

Example 16.12 (a) Propane (g) at 25°C and 100 kPa is burned with 400% theoretical air at 25°C and 100 kPa. Assume that the reaction occurs reversibly at 25°C, that the oxygen and nitrogen are separated before the reaction takes place (each at 100 kPa, 25°C), that the constituents in the products are separated, and that each is at 25°C, 100 kPa. Determine the reversible work for this process. (b) If the above reaction occurs adiabatically, and each constituent in the products is at 100 kPa pressure and at the adiabatic flame temperature, compute (a) the increase in entropy during combustion, (b) the irreversibility of the process, and (c) the availability of the products of combustion.

Solution The combustion equation (Fig. Ex. 16.12) is

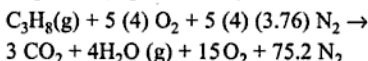

$$(a) W_{\text{rev}} = \sum_R n_i \bar{g}_i - \sum_P n_e \bar{g}_e$$

From Table 16.1

$$\begin{aligned} W_{\text{rev}} &= (\bar{g}_{f,0})_{\text{C}_3\text{H}_8(\text{g})} - 3(\bar{g}_{f,0})_{\text{CO}_2} - 4(\bar{g}_{f,0})_{\text{H}_2\text{O}(\text{g})} \\ &= -23,316 - 3(-394,374) - 4(-228,583) \\ &= 2,074,128 \text{ kJ/kgmol} \quad \text{Ans.} \\ &= \frac{2,074,128}{44.097} = 47,035.6 \text{ kJ/kg} \quad \text{Ans.} \end{aligned}$$

$$(b) H_R = H_P$$

$$\begin{aligned} (\bar{h}_{r,0})_{\text{C}_3\text{H}_8(\text{g})} &= 3(\bar{h}_{r,0} + \Delta\bar{h})_{\text{CO}_2} + 4(\bar{h}_{r,0} + \Delta\bar{h})_{\text{H}_2\text{O}(\text{g})} \\ &\quad + 15 \Delta\bar{h}_{\text{O}_2} + 75.2 \Delta\bar{h}_{\text{N}_2} \end{aligned}$$

From Table 16.1

$$\begin{aligned} -103,847 &= 3(-393,522 + \Delta\bar{h})_{\text{CO}_2} + 4(-241,827 + \Delta\bar{h})_{\text{H}_2\text{O}(\text{g})} \\ &\quad + 15 \Delta\bar{h}_{\text{O}_2} + 75.2 \Delta\bar{h}_{\text{N}_2} \end{aligned}$$

Using Table C in the appendix, and by trial and error, the adiabatic flame temperature is found to be 980 K.

The entropy of the reactants

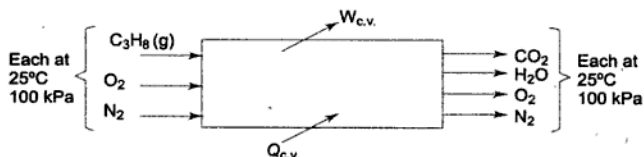

Fig. Ex. 16.12

temperature of the products is limited to 827°C. Estimate the air-fuel ratio used and the percentage excess air.

Ans. 66, 338%

- 16.18 A mixture of methane and oxygen, in the proper ratio for complete combustion and at 25°C and 1 atm, reacts in a constant volume calorimeter bomb. Heat is transferred until the products of combustion are at 400 K. Determine the heat transfer per mole of methane.

Ans. - 794414 kJ/kgmol

- 16.19 Liquid hydrazine (N_2H_4) and oxygen gas, both at 25°C, 0.1 MPa are fed to a rocket combustion chamber in the ratio of 0.5 kg O_2 /kg N_2H_4 . The heat transfer from the chamber to the surroundings is estimated to be 100 kJ/kg N_2H_4 . Determine the temperature of the products, assuming only H_2O , H_2 , and N_2 to be present. The enthalpy of the formation of N_2H_4 (l) is + 50, 417 kJ/kgmol.

Ans. 2855 K

If saturated liquid oxygen at 90 K is used instead of 25°C oxygen gas in the combustion process, what will the temperature of the products be?

- 16.20 Liquid ethanol (C_2H_5OH) is burned with 150% theoretical oxygen in a steady flow process. The reactants enter the combustion chamber at 25°C, and the products are cooled and leave at 65°C, 0.1 MPa. Calculate the heat transfer per kg mol of ethanol. The enthalpy of formation of C_2H_5OH (l) is - 277, 634 kJ/kg mol.

- 16.21 A small gas turbine uses C_8H_{18} (l) for fuel and 400% theoretical air. The air and fuel enter at 25°C and the combustion products leave at 900 K. If the specific fuel consumption is 0.25 kg/s per MW output, determine the heat transfer from the engine per kg mol of fuel, assuming complete combustion.

Ans. - 48,830 kJ/kgmol.

- 16.22 Hydrogen peroxide (H_2O_2) enters a gas generator at the rate of 0.1 kg/s, and is decomposed to steam and oxygen. The resulting mixture is expanded through a turbine to atmospheric pressure, as shown in Fig. P 16.22. Determine the power output of the turbine and the heat transfer rate in the gas generator. The enthalpy of formation of H_2O_2 (l) is - 187,583 kJ/kgmol.

Ans. 38.66 kW, - 83.3 kW

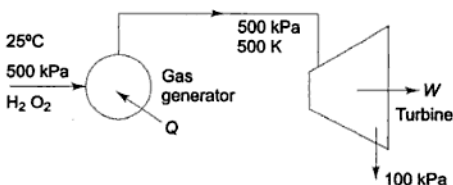

Fig. P 16.22

- 16.23 An internal combustion engine burns liquid octane and uses 150% theoretical air. The air and fuel enter at 25°C, and the products leave the engine exhaust ports at 900 K. In the engine 80% of the carbon burns to CO_2 and the remainder burns to CO . The heat transfer from this engine is just equal to the work done by the engine. Determine (a) the power output of the engine if the engine burns

Compressible Fluid Flow

A fluid is defined as a substance which continuously deforms under the action of shearing forces. Liquids and gases are termed as fluids. A fluid is said to be *incompressible* if its density (or specific volume) does not change (or changes very little) with a change in pressure (or temperature or velocity). Liquids are incompressible. A fluid is said to be *compressible* if its density changes with a change in pressure or temperature or velocity. Gases are compressible. The effect of compressibility must be considered in flow problems of gases. Thermodynamics is an essential tool in studying compressible flows, because of which Theodore Von Karman suggested the name 'Aerothermodynamics' for the subject which studies the dynamic of compressible fluids.

The basic principles in compressible flow are:

- (a) Conservation of mass (continuity equation)
- (b) Newton's second law of motion (momentum principle)
- (c) Conservation of energy (first law of thermodynamics)
- (d) Second law of thermodynamics (entropy principle)
- (e) Equation of state.

For the first two principles, the student is advised to consult a book on fluid mechanics, and the last three principles have been discussed in the earlier chapters of this book.

17.1 Velocity of Pressure Pulse in a Fluid

Let us consider an infinitesimal pressure wave initiated by a slight movement of a piston to the right (Fig. 17.1) in a pipe of uniform cross-section. The pressure wave front propagates steadily with a velocity c , which is known as the velocity of sound, sonic velocity or acoustic velocity. The fluid near the piston will have a slightly increased pressure and will be slightly more dense, than the fluid away from the piston.

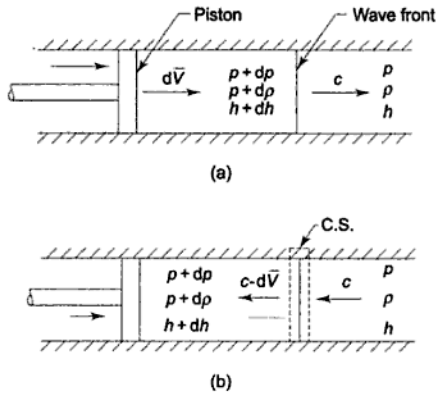

Fig. 17.1 Diagram illustrating sonic velocity (a) Stationary observer, (b) Observer travelling with the wave front

To simplify the analysis, let the observer be assumed to travel with the wave front to the right with the velocity c . Fluid flows steadily from right to left and as it passes through the wave front, the velocity is reduced from c to $c - dV$. At the same time, the pressure rises from p to $p + dp$ and the density from ρ to $\rho + d\rho$.

The continuity equation for the control volume gives

$$\begin{aligned}\rho A c &= (\rho + d\rho) A (c - dV) \\ \rho c &= \rho c - \rho dV + c d\rho - d\rho \cdot dV\end{aligned}$$

Neglecting the product $d\rho \cdot dV$, both being very small

$$\rho dV = c d\rho \quad (17.1)$$

The momentum equation for the control volume gives

$$\begin{aligned}[p - (p + dp)] A &= w [(c - dV) - c] \\ - dp A &= \rho A c (c - dV - c) \\ dp &= \rho c dV\end{aligned} \quad (17.2)$$

From Eqs (17.1) and (17.2)

$$\frac{dp}{c} = c d\rho$$

$$\therefore c = \sqrt{\frac{dp}{d\rho}}$$

Since the variations in pressure and temperature are negligibly small and the change of state is so fast as to be essentially adiabatic, and in the absence of any internal friction or viscosity, the process is reversible and isentropic. Hence, the sonic velocity is given by

$$c = \sqrt{\left(\frac{\partial p}{\partial \rho}\right)_s} \quad (17.3)$$

No fluid is truly incompressible, although liquids show little change in density. The velocity of sound in common liquids is of the order of 1650 m/s.

17.1.1 Velocity of Sound in an Ideal Gas

For an ideal gas, in an isentropic process

$$pv^\gamma = \text{constant}$$

$$\text{or } \frac{p}{\rho^\gamma} = \text{constant}$$

By logarithmic differentiation (i.e., first taking logarithm and then differentiating)

$$\frac{dp}{p} - \gamma \frac{d\rho}{\rho} = 0$$

$$\therefore \frac{dp}{d\rho} = \gamma \frac{p}{\rho}$$

$$\text{Since } c^2 = \frac{dp}{d\rho} \text{ and } p = \rho RT$$

$$c^2 = \gamma RT$$

$$\text{or } c = \sqrt{\gamma RT} \quad (17.4)$$

where R = characteristic gas constant

$$= \frac{\text{Universal gas constant}}{\text{Molecular weight}}$$

The lower the molecular weight of the fluid and higher the value of γ , the higher is the sonic velocity at the same temperature. c is a thermodynamic property of the fluid.

17.1.2 Mach Number

The Mach number, M , is defined as the ratio of the actual velocity V to the sonic velocity c .

$$M = \frac{V}{c}$$

When $M > 1$, the flow is supersonic, when $M < 1$, the flow is subsonic, and when $M = 1$, the flow is sonic.

17.2 Stagnation Properties

The isentropic *stagnation state* is defined as the state a fluid in motion would reach if it were brought to rest isentropically in a steady-flow, adiabatic, zero

work output device. This is the reference state in a compressible fluid flow and is commonly designated with the subscript zero. The stagnation enthalpy h_0 (Fig. 17.2) is related to the enthalpy and velocity of the moving fluid by

$$h_0 = h + \frac{V^2}{2} \quad (17.5)$$

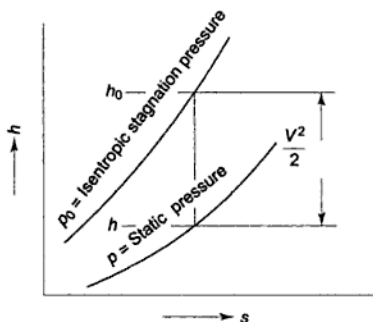

Fig. 17.2 Stagnation state

For an ideal gas, $h = h(T)$ and c_p is constant. Therefore

$$h_0 - h = c_p (T_0 - T) \quad (17.6)$$

From Eq. (17.5) and (17.6)

$$c_p(T_0 - T) = \frac{V^2}{2}$$

$$\frac{T_0}{T} = 1 + \frac{V^2}{2c_p T}$$

The properties without any subscript denote static properties.

Since

$$c_p = \frac{\gamma R}{\gamma - 1}$$

$$\frac{T_0}{T} = 1 + \frac{V^2(\gamma - 1)}{2\gamma RT}$$

Using Eq. (17.4) and the Mach number

$$\frac{T_0}{T} = 1 + \frac{\gamma - 1}{2} M^2 \quad (17.7)$$

The stagnation pressure p_0 is related to the Mach number and static pressure in the case of an ideal gas by the following equation

$$\frac{p_0}{p} = \left(\frac{T_0}{T}\right)^{\gamma/(\gamma-1)} = \left(1 + \frac{\gamma-1}{2} M^2\right)^{\gamma/(\gamma-1)} \quad (17.8)$$

$$\text{or } \frac{dp}{dV} < 0 \quad (17.12)$$

As pressure decreases, velocity increases, and vice versa.

The continuity equation gives

$$w = \rho A V$$

By logarithmic differentiation

$$\frac{d\rho}{\rho} + \frac{dA}{A} + \frac{dV}{V} = 0$$

$$\therefore \frac{dA}{A} = -\frac{dV}{V} - \frac{d\rho}{\rho}$$

Substituting from Eq. (17.11)

$$\frac{dA}{A} = \frac{dp}{\rho V^2} - \frac{d\rho}{\rho} = \frac{dp}{\rho V^2} \left[1 - V^2 \frac{d\rho}{dp} \right]$$

$$\text{or } \frac{dA}{A} = \frac{dp}{\rho V^2} (1 - M^2) \quad (17.13)$$

$$\text{Also } \frac{dA}{A} = (M^2 - 1) \frac{dV}{V} \quad (17.14)$$

When $M < 1$, i.e., the inlet velocity is subsonic, as flow area A decreases, the pressure decreases and velocity increases, and when flow area A increases, pressure increases and velocity decreases. So for subsonic flow, a convergent passage becomes a nozzle (Fig. 17.4a) and a divergent passage becomes a diffuser (Fig. 17.4b)

When $M > 1$, i.e., when the inlet velocity is supersonic, as now area A decreases, pressure increases and velocity decreases, and as flow area A

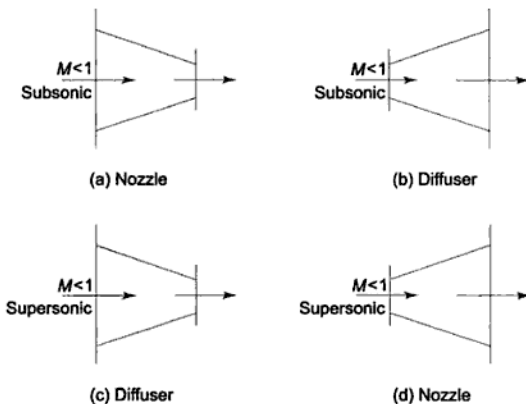

Fig. 17.4 Effect of area change in subsonic and supersonic flow at inlet to duct

increases, pressure decreases and velocity increases. So for supersonic flow, a convergent passage is a diffuser (Fig. 17.4c) and a divergent passage is a nozzle (Fig. 17.4d).

17.4 Critical Properties—Choking in Isentropic Flow

Let us consider the mass rate of flow of an ideal gas through a nozzle. The flow is isentropic

$$w = \rho A V$$

$$\begin{aligned} \text{or } \frac{w}{A} &= \frac{P}{RT} \cdot cM = \frac{P}{RT} \sqrt{\gamma RT} \cdot M \\ &= \frac{P}{P_0} \cdot P_0 \sqrt{\frac{T_0}{T}} \cdot \sqrt{\frac{1}{T_0}} \sqrt{\frac{\gamma}{R}} \cdot M \\ &= \left(\frac{T_0}{T}\right)^{-\gamma/\gamma-1} \left(\frac{T_0}{T}\right)^{1/2} \cdot \frac{P_0}{\sqrt{T_0}} \sqrt{\frac{\gamma}{R}} \cdot M \\ &= \sqrt{\frac{\gamma}{R}} \frac{P_0 M}{\sqrt{T_0}} \cdot \frac{1}{\left(1 + \frac{\gamma-1}{2} M^2\right)^{(\gamma+1)/2(\gamma-1)}} \quad (17.15) \end{aligned}$$

Since P_0 , T_0 , γ and R are constant, the discharge per unit area w/A is a function of M only. There is a particular value of M when w/A is a maximum. Differentiating equation (17.15) with respect to M and equating it to zero,

$$\begin{aligned} \frac{d(w/A)}{dM} &= \sqrt{\frac{\gamma}{R}} \cdot \frac{P_0}{\sqrt{T_0}} \frac{1}{\left(1 + \frac{\gamma-1}{2} M^2\right)^{(\gamma+1)/2(\gamma-1)}} \\ &+ \sqrt{\frac{\gamma}{R}} \cdot \frac{P_0 M}{\sqrt{T_0}} \left[-\frac{\gamma+1}{2(\gamma-1)} \right] \left(1 + \frac{\gamma-1}{2} M^2\right)^{-\frac{\gamma+1}{2(\gamma-1)}-1} \\ &\quad \left(\frac{\gamma-1}{2} \cdot 2M\right) = 0 \\ 1 - \frac{M^2(\gamma+1)}{2\left(1 + \frac{\gamma-1}{2} M^2\right)} &= 0 \\ M^2(\gamma+1) &= 2 + (\gamma-1) M^2 \\ M^2 &= 1 \end{aligned}$$

$$\text{or } M = 1$$

So, the discharge w/A is maximum when $M = 1$.

Since $V = cM = \sqrt{\gamma RT} \cdot M$, by logarithmic differentiation

For diatomic gases, like air, $\gamma = 1.4$

$$\frac{p^*}{p_0} = \left(\frac{2}{2.4} \right)^{1.4/0.4} = 0.528$$

The critical pressure ratio for air is 0.528.

For superheated steam, $\gamma = 1.3$ and p^*/p_0 is 0.546.

For air,
$$\frac{T^*}{T_0} = 0.833$$

and
$$\frac{\rho^*}{\rho_0} = \left(\frac{2}{\gamma+1} \right)^{1/(\gamma-1)} = 0.634$$

By substituting $M = 1$ in equation (17.15)

$$\frac{w}{A^*} = \sqrt{\frac{\gamma}{R}} \cdot \frac{p_0}{\sqrt{T_0}} \cdot \frac{1}{\left(\frac{\gamma+1}{2} \right)^{(\gamma+1)/2(\gamma-1)}} \quad (17.21)$$

Dividing Eq. (17.21) by Eq. (17.15)

$$\frac{A}{A^*} = \left[\left(\frac{2}{\gamma+1} \right) \left(1 + \frac{\gamma-1}{2} M^2 \right) \right]^{(\gamma+1)/2(\gamma-1)} \frac{1}{M} \quad (17.22)$$

The area ratio A/A^* is the ratio of the area at the point where the Mach number is M to the throat area A^* . Figure 17.5 shows a plot of A/A^* vs. M , which shows that a subsonic nozzle is converging and a supersonic nozzle is diverging.

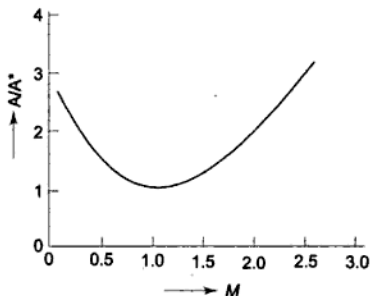

Fig. 17.5 Area ratio as a function of Mach number in an isentropic nozzle

17.4.1 Dimensionless Velocity, M^*

Since the Mach number M is not proportional to the velocity alone and it tends towards infinity at high speeds, one more dimensionless parameter M^* is often used, which is defined as

$$M^* = \frac{V}{c^*} = \frac{V}{V^*} \quad (17.23)$$

where $c^* = \sqrt{\gamma RT^*} = V^*$

$$\begin{aligned} \therefore M^{*2} &= \frac{V^2}{c^{*2}} = \frac{V^2}{c^2} \cdot \frac{c^2}{c^{*2}} \\ &= M^2 \cdot \frac{c^2}{c^{*2}} \end{aligned}$$

For the adiabatic flow of an ideal gas

$$\begin{aligned} \frac{V^2}{2} + c_p T &= \text{constant} = h_0 = c_p T_0 \\ \frac{V^2}{2} + \frac{\gamma RT}{\gamma - 1} &= \frac{\gamma RT_0}{\gamma - 1} \\ \frac{V^2}{2} + \frac{c^2}{\gamma - 1} &= \frac{c_0^2}{\gamma - 1} \end{aligned}$$

Since $\frac{c_0}{c^*} = \frac{\sqrt{\gamma RT_0}}{\sqrt{\gamma RT^*}} = \sqrt{\frac{T_0}{T^*}} = \sqrt{\left(\frac{\gamma + 1}{2}\right)}$

$$\begin{aligned} \therefore \frac{V^2}{2} + \frac{c^2}{\gamma - 1} &= \frac{\gamma + 1}{2} c^{*2} \frac{1}{\gamma - 1} \\ \frac{V^2}{c^{*2}} + \frac{2}{\gamma - 1} \frac{c^2}{c^{*2}} &= \frac{\gamma + 1}{\gamma - 1} \\ M^{*2} + \frac{2}{\gamma - 1} \frac{M^{*2}}{M^2} &= \frac{\gamma + 1}{\gamma - 1} \end{aligned}$$

On simplification

$$M^{*2} = \frac{\frac{\gamma + 1}{2} M^2}{1 + \frac{\gamma - 1}{2} M^2} \quad (17.24)$$

When $M < 1$, $M^* < 1$

When $M > 1$, $M^* > 1$

When $M = 1$, $M^* = 1$

When $M = 0$, $M^* = 0$

When $M = \infty$, $M^* = \sqrt{\frac{\gamma + 1}{\gamma - 1}}$

17.4.2 Pressure Distribution and Choking in a Nozzle

Let us first consider a convergent nozzle as shown in Fig. 17.6, which also shows the pressure ratio p/p_0 along the length of the nozzle. The inlet condition of the fluid is the stagnation state at p_0 , T_0 , which is assumed to be constant. The

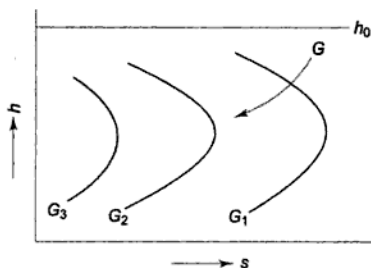

Fig. 17.11 Fanno line on h - s diagram

Let us next consider the locus of states which are defined by the continuity Eq. (17.25), the momentum Eq. (17.26) and the Eq. of state (17.29). The impulse function in this case becomes

$$F = pA + \rho AV^2$$

or the impulse pressure I is given by

$$I = \frac{F}{A} = p + \rho V^2 = p + \frac{G^2}{\rho} \quad (17.31)$$

Given the values for I and G , the equation relates p and ρ . The line representing the locus of states with the same impulse pressure and mass velocity is called the *Rayleigh line*. The end states of the normal shock must lie on the Rayleigh line, since $I_x = I_y$, and $G_x = G_y$.

The Rayleigh line may also be drawn on the h - s plot. The properties upstream of the shock are all known. The downstream properties are to be known. Let a particular value of V_y be chosen. Then ρ_y may be computed from the continuity equation (17.25) and p_y from the momentum equation (17.26), and s_y from equation (17.29b) may be found. By repeating the calculations for various values of V_y , the locus of possible states reachable from, say, state x may be plotted, and this is the Rayleigh line (Fig. 17.12).

Since the normal shock must satisfy Eqs (17.25), (17.26), (17.27), and (17.29) simultaneously, the end states x and y of the shock must lie at the intersections of the Fanno line and the Rayleigh line for the same G (Fig. 17.12).

The Rayleigh line is also a model for flow in a constant area duct with heat transfer, but without friction.

For an infinitesimal process in the neighbourhood of the point of maximum entropy (point a) on the Fanno line, from the energy equation

$$dh + VdV = 0 \quad (17.32)$$

and from the continuity equation

$$\rho dV + Vd\rho = 0 \quad (17.33)$$

From the thermodynamic relation

$$Td s = dh - v dp$$

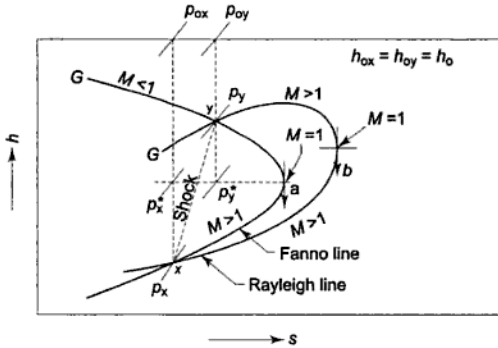

Fig. 17.12 End states of a normal shock on h - s diagram

$$\text{or} \quad dh = \frac{dp}{\rho} \quad (17.34)$$

By combining Eqs (17.32), (17.33), (17.34)

$$\frac{dp}{\rho} + V \left(-\frac{V d\rho}{\rho} \right) = 0$$

$$\therefore \quad \frac{dp}{d\rho} = V^2$$

or $V = \sqrt{\left(\frac{\partial p}{\partial \rho} \right)_s}$, since the flow is isentropic.

This is the local sound velocity.

So the Mach number is unity at point a . Similarly, it can be shown that at point b on the Rayleigh line, $M = 1$. It may also be shown that the upper branches of the Fanno and Rayleigh lines represent subsonic speeds ($M < 1$) and the lower branches represent supersonic speeds ($M > 1$).

The normal shock always involves a change from supersonic to subsonic speed with a consequent pressure rise, and never the reverse. By the second law, entropy always increases during irreversible adiabatic change.

17.5.1 Normal Shock in an Ideal Gas

The energy equation for an ideal gas across the shock becomes

$$c_p T_x + \frac{V_x^2}{2} = c_p T_y + \frac{V_y^2}{2} = c_p T_0$$

Now $h_{0x} = h_{0y} = h_0$, and $T_{0x} = T_{0y} = T_0$

Substituting $c_p = \frac{\gamma R}{\gamma - 1}$, $c_x = \sqrt{\gamma R T_x}$, and $c_y = \sqrt{\gamma R T_y}$

$$\frac{T_y}{T_x} = \frac{\left(1 + \frac{\gamma-1}{2} M_x^2\right) \left(\frac{2\gamma}{\gamma-1} M_x^2 - 1\right)}{\frac{(\gamma+1)^2}{2(\gamma-1)} M_x^2} \quad (17.41)$$

Then

$$\begin{aligned} \frac{\rho_y}{\rho_x} &= \frac{p_y}{T_y} \cdot \frac{T_x}{p_x} \\ &= \frac{\left(\frac{2\gamma}{\gamma+1} M_x^2 - \frac{\gamma-1}{\gamma+1}\right) \left(\frac{(\gamma+1)^2}{2(\gamma-1)} M_x^2\right)}{\left(1 + \frac{\gamma-1}{2} M_x^2\right) \left(\frac{2\gamma}{\gamma-1} M_x^2 - 1\right)} \end{aligned} \quad (17.42)$$

The ratio of the stagnation pressures is a measure of the irreversibility of the shock process. Now

$$\frac{p_{0y}}{p_{0x}} = \frac{p_{0y}}{p_y} \cdot \frac{p_y}{p_x} \cdot \frac{p_x}{p_{0x}}$$

and

$$\frac{p_{0y}}{p_y} = \left(1 + \frac{\gamma-1}{2} M_y^2\right)^{\gamma/(\gamma-1)}$$

$$\frac{p_{0x}}{p_x} = \left(1 + \frac{\gamma-1}{2} M_x^2\right)^{\gamma/(\gamma-1)}$$

$$\therefore \frac{p_{0y}}{p_{0x}} = \left\{ \frac{\frac{\gamma+1}{2} M_x^2}{1 + \frac{\gamma-1}{2} M_x^2} \right\}^{\gamma/(\gamma-1)} \left/ \left[\frac{2\gamma}{\gamma+1} M_x^2 - \frac{\gamma-1}{\gamma+1} \right]^{1/(\gamma-1)} \right. \quad (17.43)$$

$$\frac{p_{0y}}{p_x} = \frac{p_{0y}}{p_y} \cdot \frac{p_y}{p_x}$$

$$= \left(1 + \frac{\gamma-1}{2} M_y^2\right)^{\gamma/(\gamma-1)} \left[\frac{2\gamma}{\gamma+1} M_x^2 - \frac{\gamma-1}{\gamma+1} \right] \quad (17.44)$$

For different values of M_x , and for $\gamma = 1.4$, the values of M_y , p_y/p_x , T_y/T_x , ρ_y/ρ_x , p_{0y}/p_{0x} , and p_{0y}/p_x computed from Eqs (17.39), (17.40), (17.42), (17.43), and (17.44) respectively, are given in Table D.2 in the appendix.

To evaluate the entropy change across the shock, for an ideal gas

$$ds = c_p \frac{dT}{T} - R \frac{dp}{p}$$

$$\begin{aligned} \therefore s_y - s_x &= c_p \ln \frac{T_y}{T_x} - R \ln \frac{p_y}{p_x} \\ &= c_p \left[\ln \frac{T_y}{T_x} - \ln \left(\frac{p_y}{p_x} \right)^{(\gamma-1)/\gamma} \right] \end{aligned}$$

since
$$R = \frac{c_p(\gamma-1)}{\gamma}$$

$$\begin{aligned} \therefore s_y - s_x &= c_p \ln \frac{T_y/T_x}{(p_y/p_x)^{(\gamma-1)/\gamma}} \\ &= c_p \ln \frac{T_{oy}/T_{ox}}{(p_{oy}/p_{ox})^{(\gamma-1)/\gamma}} = -R \ln \frac{p_{oy}}{p_{ox}} \quad (17.45) \end{aligned}$$

The strength of a shock wave, P , is defined as the ratio of the pressure increase to the initial pressure, i.e.

$$P = \frac{p_y - p_x}{p_x} = \frac{p_y}{p_x} - 1$$

Substituting from Eq. (17.40)

$$\begin{aligned} P &= \frac{2\gamma}{\gamma+1} M_x^2 - \frac{\gamma-1}{\gamma+1} - 1 \\ &= \frac{2\gamma}{\gamma+1} (M_x^2 - 1) \quad (17.46) \end{aligned}$$

17.6 Adiabatic Flow with Friction and Diabatic Flow without Friction

It was stated that the Fanno line representing the states of constant mass velocity and constant stagnation enthalpy also holds for adiabatic flow in a constant area duct with friction. For adiabatic flow the entropy must increase in the flow direction. Hence a Fanno process must follow its Fanno line to the right, as shown in Fig. 17.13. Since friction will tend to move the state of the fluid to the right on the Fanno line, the Mach number of subsonic flows increases in the downstream section (Fig. 17.13), and in supersonic flows friction acts to decrease the Mach number. Hence, friction tends to drive the flow to the sonic point.

Let us consider a short duct with a given h_0 and G , i.e. a given Fanno line with a given subsonic exit Mach number represented by point 1 in Fig. 17.13. If some more length is added to the duct, the new exit Mach number will be increased due to friction, as represented by, say, point 2. The length of the duct may be further increased till the exit Mach number is unity. Any further increase in duct length is not possible without incurring a reduction in the mass flow rate. Hence subsonic

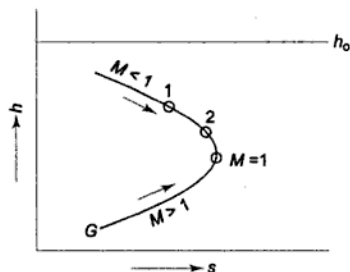

Fig. 17.13 A Fanno line on h - s plot

flows can be choked by friction. There is a maximum flow rate that can be passed by a pipe with given stagnation conditions. Choking also occurs in supersonic flow with friction, usually in a very short length. It is thus difficult to use such flows in applications.

Diabatic flows, i.e., flows with heating or cooling, in a constant area duct, in the absence of friction, can be treated by the Rayleigh process (Fig. 17.14). The process is reversible, and the direction of entropy change is determined by the sign of the heat transfer. Heating a compressible flow has the same effect as friction, and the Mach number goes towards unity. Therefore, there is a maximum heat input for a given flow rate which can be passed by the duct, which is then choked. Although the cooling of the fluid increases the flow stagnation pressure with a decrease in entropy, a nonmechanical pump is not feasible by cooling a compressible flow, because of the predominating effect of friction.

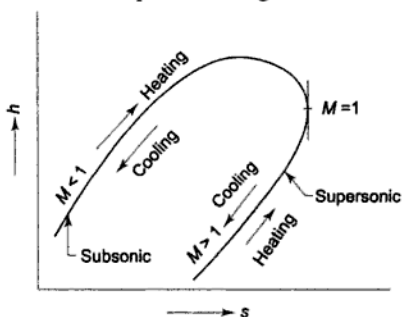

Fig. 17.14 A Rayleigh line on h - s plot

SOLVED EXAMPLES

Example 17.1 A stream of air flows in a duct of 100 mm diameter at a rate of 1 kg/s. The stagnation temperature is 37°C. At one section of the duct the static

$$\frac{T_2}{T_1} = \frac{T_2/T_{02}}{T_1/T_{01}} = \frac{0.996}{0.89644} = 1.111$$

$$\frac{F_2}{F_1} = \frac{F_2/F^*}{F_1/F^*} = \frac{3.46}{1.0284} = 3.364$$

$$p_2 = 1.447 \times 0.18 = 0.26 \text{ MPa}$$

$$T_2 = 1.111 \times 310 = 344.4 \text{ K} = 71.3^\circ\text{C}$$

Ans.

Impulse function at inlet

$$\begin{aligned} F_1 &= p_1 A_1 + \rho_1 A_1 V_1^2 \\ &= p_1 A_1 \left(1 + \frac{1}{\gamma} \frac{\rho_1}{p_1} V_1^2 \right) \\ &= p_1 A_1 (1 + \gamma M_1^2) \\ &= 0.18 \times 10^3 \times 0.11 (1 + 1.4 \times 0.76^2) \\ &= 35.82 \text{ kN} \end{aligned}$$

Internal thrust τ will be from right to left, as shown in Fig. Ex. 17.2

$$\begin{aligned} \tau_{\text{int}} &= F_2 - F_1 = 3.364 F_1 - F_1 \\ &= 2.364 \times 35.82 \\ &= 84.68 \text{ kN} \end{aligned}$$

External thrust is from left to right

$$\begin{aligned} \tau_{\text{ext}} &= p_0 (A_2 - A_1) \\ &= 0.1 \times 10^3 (0.44 - 0.11) \\ &= 33 \text{ kN} \end{aligned}$$

Net thrust

$$\begin{aligned} &= \tau_{\text{int}} - \tau_{\text{ext}} \\ &= 84.68 - 33 = 51.68 \text{ kN} \end{aligned}$$

Ans. (c)

Example 17.3 A convergent-divergent nozzle has a throat area 500 mm^2 and an exit area of 1000 mm^2 . Air enters the nozzle with a stagnation temperature of 360 K and a stagnation pressure of 1 MPa . Determine the maximum flow rate of air that the nozzle can pass, and the static pressure, static temperature, Mach number, and velocity at the exit from the nozzle, if (a) the divergent section acts as a nozzle, and (b) the divergent section acts as a diffuser.

Solution

$$\frac{A_2}{A^*} = \frac{1000}{500} = 2$$

From the isentropic flow tables, when $A_2/A^* = 2$ there are two values of the Mach number, one for supersonic flow when the divergent section acts as a nozzle, and the other for subsonic flow when the divergent section acts as a diffuser, which are $M_2 = 2.197, 0.308$ (Fig. Ex. 17.3).

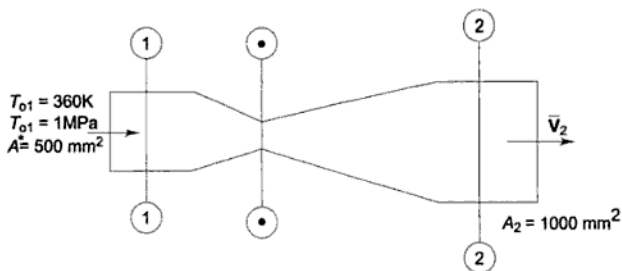

Fig. Ex. 17.3

(a) When $M_2 = 2.197$, $\frac{p_2}{p_0} = 0.0939$, $\frac{T_2}{T_0} = 0.5089$

$\therefore p_2 = 0.0939 \times 1000 = 93.9 \text{ kPa}$

$T_2 = 0.5089 \times 360 = 183.2 \text{ K}$

$c_2 = \sqrt{\gamma RT_2} = 20.045 \sqrt{183.2}$
 $= 271.2 \text{ m/s}$

$\therefore V_2 = 271.2 \times 2.197 = 596 \text{ m/s}$

Ans.

Mass flow rate

$$w = A^* \rho^* V^* = \rho_2 A_2 V_2 = \rho_1 A_1 V_1$$

For air

$$\frac{p^*}{p_0} = 0.528 \text{ and } \frac{T^*}{T_0} = 0.833$$

$$\rho^* = \frac{p^*}{RT^*} = \frac{0.528 \times 1000}{0.287 \times 0.833 \times 360} = 6.13 \text{ kg/m}^3$$

$$T^* = 360 \times 0.833 = 300 \text{ K}$$

$$V^* = \sqrt{\gamma RT^*} = 20.045 \sqrt{300}$$

 $= 347.2 \text{ m/s}$

$\therefore w = (500 \times 10^{-6}) \times 6.13 \times 347.2$
 $= 1.065 \text{ kg/s}$

Ans.

(b) When $M = 0.308$, $\frac{p_2}{p_0} = 0.936$, $\frac{T_2}{T_0} = 0.9812$

$p_2 = 0.936 \times 1000 = 936 \text{ kPa}$

$T_2 = 0.9812 \times 360 = 353.2 \text{ K}$

$c_2 = \sqrt{\gamma RT_2} = 20.045 \sqrt{353.2} = 376.8 \text{ m/s}$

$V_2 = 376.8 \times 0.308 = 116 \text{ m/s}$

$w = 1.065 \text{ kg/s}$

Ans.

Example 17.4 When a Pitot tube is immersed in a supersonic stream, a curved shock wave is formed ahead of the Pitot tube mouth. Since the radius of the curvature of the shock is large, the shock may be assumed to be a normal shock. After the normal shock, the fluid stream decelerates isentropically to the total pressure p_{oy} at the entrance to the Pitot tube.

A Pitot tube traveling in a supersonic wind-tunnel gives values of 16 kPa and 70 kPa for the static pressure upstream of the shock and the pressure at the mouth of the tube respectively. Estimate the Mach number of the tunnel. If the stagnation temperature is 300°C, calculate the static temperature and the total (stagnation) pressure upstream and downstream of the tube.

Solution With reference to the Fig. Ex. 17.4

$$p_x = 16 \text{ kPa}, p_{oy} = 70 \text{ kPa}$$

$$\therefore \frac{p_{oy}}{p_x} = \frac{70}{16} = 4.375$$

From the gas tables for normal shock

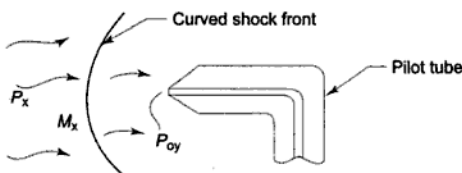

Fig. Ex. 17.4

$$\text{When} \quad \frac{p_{oy}}{p_x} = 4.375, M_x = 1.735, \frac{p_y}{p_x} = 3.34, \frac{\rho_y}{\rho_x} = 2.25$$

$$\frac{T_y}{T_x} = 1.483, \frac{p_{oy}}{p_{ox}} = 0.84, M_y = 0.631$$

$$T_{ox} = T_{oy} = 573 \text{ K}$$

$$T_{ox} = \left(1 + \frac{\gamma - 1}{2} M_x^2\right) T_x \\ = (1 + 0.2 \times 3) T_x = 1.6 T_x$$

$$\therefore T_x = \frac{573}{1.6} = 358 \text{ K}$$

$$\therefore T_y = 358 \times 1.483 = 530 \text{ K} = 257^\circ\text{C}$$

$$p_{ox} = \frac{p_{oy}}{0.84} = \frac{70}{0.84} = 83.3 \text{ kPa}$$

$$M_x = 1.735$$

Ans.

$$\therefore \frac{A_2}{A^*} = \frac{A_2 A_y}{A_y A^*} = \frac{25}{18.75} \times 1.183 = 1.582$$

When $A_2/A^* = 1.582$, from the isentropic flow tables, $M_2 = 0.402$ *Ans.*

$$\frac{p_2}{p_{0y}} = 0.895$$

$$\therefore p_2 = 0.895 \times 165.3 = 147.94 \text{ kPa} \quad \textit{Ans.}$$

Loss in stagnation pressure occurs only across the shock

$$p_{0x} - p_{0y} = 210 - 165.3 = 44.7 \text{ kPa} \quad \textit{Ans.}$$

Entropy increase, $s_y - s_x$

$$\begin{aligned} &= -R \ln \frac{p_{0y}}{p_{0x}} \\ &= 0.287 \ln \frac{210}{165.3} \\ &= 0.287 \times 0.239 = 0.0686 \text{ kJ/kg K} \quad \textit{Ans.} \end{aligned}$$

REVIEW QUESTIONS

- 17.1 What is a compressible fluid?
- 17.2 What are the basic laws in compressible flow?
- 17.3 How is sonic velocity defined in terms of pressure and density of the fluid?
- 17.4 Show that the sonic velocity in an ideal gas depends on the temperature and the nature of the gas.
- 17.5 What is Mach number?
- 17.6 What is a stagnation state? What do you mean by stagnation properties?
- 17.7 What are a nozzle and a diffuser?
- 17.8 Explain the effect of area change in subsonic and supersonic flows.
- 17.9 What do you understand by choking in nozzle flows?
- 17.10 Show that the discharge through a nozzle is maximum when there is a sonic condition at its throat.
- 17.11 What do you understand by critical pressure ratio? What is its value for air?
- 17.12 Explain the effect of area ratio as a function of Mach number in an isentropic nozzle?
- 17.13 What is M^* ?
- 17.14 What is a shock? Where does it occur in a nozzle?
- 17.15 What is the impulse function?
- 17.16 What is a Fanno line? Why do the end states of a normal shock lie on the Fanno line?
- 17.17 What is a Rayleigh line? Why do the end states of a normal shock also lie on the Rayleigh line?
- 17.18 Where does the local sound velocity occur on the Fanno line and on the Rayleigh line?
- 17.19 How is the strength of a shock defined?

- 17.20 Explain the occurrence of choking for adiabatic flow with friction and for diabatic flow without friction.

PROBLEMS

- 17.1 Air in a reservoir has a temperature of 27°C and a pressure of 0.8 MPa . The air is allowed to escape through a channel at a rate of 2.5 kg/s . Assuming that the air velocity in the reservoir is negligible and that the flow through the channel is isentropic, find the Mach number, the velocity, and the area at a section in the channel where the static pressure is 0.6 MPa .
- 17.2 A supersonic wind tunnel nozzle is to be designed for $M=2$, with a throat section, 0.11 m^2 in area. The supply pressure and temperature at the nozzle inlet, where the velocity is negligible, are 70 kPa and 37°C respectively. Compute the mass flow rate, the exit area, and the fluid properties at the throat and exit. Take $\gamma=1.4$.
- 17.3 An ideal gas flows into a convergent nozzle at a pressure of 0.565 MPa , a temperature of 280°C , and negligible velocity. After reversible adiabatic expansion in the nozzle the gas flows directly into a large vessel. The gas in the vessel may be maintained at any specified state while the nozzle supply state is held constant. The exit area of the nozzle is 500 mm^2 . For this gas $\gamma=1.3$ and $c_p=1.172\text{ kJ/kg K}$. Determine (a) the pressure of the gas leaving the nozzle when its temperature is 225°C , and (b) the gas mass flow rate when the pressure in the vessel is 0.21 MPa .

Ans. 0.36 MPa , 0.48 kg/s

- 17.4 Air flows adiabatically through a pipe with a constant area. At point 1, the stagnation pressure is 0.35 MPa and the Mach number is 0.4 . Further downstream the stagnation pressure is found to be 0.25 MPa . What is the Mach number at the second point for subsonic flow?
- 17.5 The intake duct to an axial flow air compressor has a diameter of 0.3 m and compresses air at 10 kg/s . The static pressure inside the duct is 67 kPa and the stagnation temperature is 40°C . Calculate the Mach number in the duct.

Ans. 0.526

- 17.6 Show that for an ideal gas the fractional change in pressure across a small pressure pulse is given by

$$\frac{dp}{p} = \gamma \frac{dV}{c}$$

and that the fractional change in absolute temperature is given by

$$\frac{dT}{T} = (\gamma - 1) \frac{dV}{c}$$

- 17.7 An airplane flies at an altitude of $13,000\text{ m}$ (temperature -55°C , pressure 18.5 kPa) with a speed of 180 m/s . Neglecting frictional effects, calculate (a) the critical velocity of the air relative to the aircraft, and (b) the maximum possible velocity of the air relative to the aircraft.

Elements of Heat Transfer

18.1 Basic Concepts

Energy balances by first law have been made in a variety of physical situations, say, in a feedwater heater or a cooling coil. However, no indication has been given regarding the size of the heat exchanger for heating or cooling of a fluid. If we consider a steel block heated in a furnace, to be allowed to cool in room air, we can estimate the amount of heat lost by the block in cooling by energy balance. But how long the cooling process will take place cannot be answered by thermodynamics. It is the science of heat transfer which is concerned with the estimation of the rate at which heat is transferred, the duration of heating or cooling for a certain heat duty and the surface area required to accomplish that heat duty.

There are three modes in which heat may be transferred: (a) conduction, (b) convection and (c) radiation.

Conduction refers to the transfer of heat between two bodies or two parts of the same body through molecules which are more or less stationary. In liquids and gases conduction results from the transport of energy by molecular motion near the wall and in solids it takes place by a combination of lattice vibration and electron transport. In general, good electrical conductors are also good thermal conductors.

Convection heat transfer occurs because of the motion of a fluid past a heated surface—the faster the motion, the greater the heat transfer. The convection heat transfer is usually assumed to be proportional to the surface area in contact with the fluid and the difference in temperature of the surface and fluid. Thus,

$$Q = hA [T_w - T_f]$$

where h is called the convection heat transfer coefficient, which is a strong function of both fluid properties and fluid velocity (W/m^2K).

Radiation heat transfer is the result of electromagnetic radiation emitted by a surface because of the temperature of the surface. This differs from other forms of electromagnetic radiation such as radio, television, X-rays and γ -rays which are not related to temperature.

18.2 Conduction Heat Transfer

Fourier's law of heat conduction states that the rate of heat flux is linearly proportional to the temperature gradient. For one dimensional or unidirectional heat conduction,

$$q \propto \frac{dt}{dx}$$

$$\text{or} \quad q = -K \frac{dt}{dx} \quad (18.1)$$

where q is the rate of heat flux in W/m^2 , dt/dx is the temperature gradient in x -direction, and K is the constant of proportionality which is a property of the material through which heat is being conducted and is known as *thermal conductivity*. q is a vector quantity. The negative sign is being used because heat flows from a high to a low temperature region and the slope dt/dx is negative.

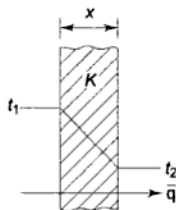

Fig. 18.1 Heat conduction through a wall

For a finite temperature difference ($t_1 - t_2$) across a wall of thickness x (Fig. 18.1)

$$q = -K \frac{t_2 - t_1}{x} = K \frac{t_1 - t_2}{x} \text{ W/m}^2$$

If A is the surface area normal to heat flow, then the rate of heat transfer

$$Q = q \cdot A = -KA \frac{t_2 - t_1}{x}$$

$$\text{or} \quad Q = KA \frac{t_1 - t_2}{x} \text{ Watts} \quad (18.2)$$

The dimension of thermal conductivity is W/mK . Since $dt/dx = q/K$ for the same q , if K is low (i.e., for an insulator), dt/dx will be large, i.e., there will be a large temperature difference across the wall, and if K is high (i.e., for a conductor), dt/dx will be small, or there will be a small temperature difference across the wall.

18.2.1 Resistance Concept

Heat flow has an analogy in the flow of electricity. Ohm's law states that the current I flowing through a wire (Fig. 18.2) is proportional to the potential difference E , or

$$I = \frac{E}{R}$$

where $1/R$ is the constant of proportionality, and R is known as the resistance of the wire, which is a property of the material. Since the temperature difference and heat flux in conduction are similar to the potential difference and electric current respectively, the heat conduction rate through the wall may be written as

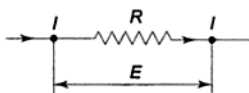

Fig. 18.2 Electrical resistance concept

$$Q = -KA \frac{t_2 - t_1}{x} = \frac{t_1 - t_2}{x/KA} = \frac{t_1 - t_2}{R}$$

where $R = x/KA$ is the thermal resistance to heat flow offered by the wall (Fig. 18.3). For a composite wall, as shown in Fig. 18.4, there are two resistances in series. The slope of the temperature profile depends on the thermal conductivity of the material. t_i is the interface temperature. The total thermal resistance

$$R = R_1 + R_2 = \frac{x_1}{K_1 A} + \frac{x_2}{K_2 A}$$

and the rate of heat flow

$$Q = \frac{t_1 - t_2}{R}$$

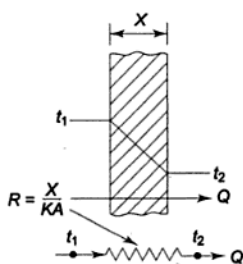

Fig. 18.3 Thermal resistance offered by a wall

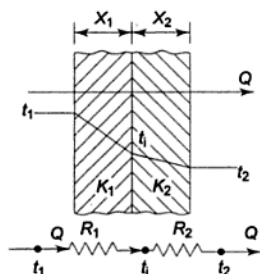

Fig. 18.4 Heat conduction through resistance in series

Again, $t_1 - t_2 = Q \cdot R_1 = Q \cdot \frac{x_1}{K_1 A}$, from which t_1 can be evaluated.

For two resistances in parallel (Fig. 18.5), the total resistance R is given by

$$\frac{1}{R} = \frac{1}{R_1} + \frac{1}{R_2} \quad \text{or} \quad R = \frac{R_1 R_2}{R_1 + R_2}$$

where $R_1 = \frac{x}{K_1 A_1}$ and $R_2 = \frac{x}{K_2 A_2}$

and the rate of heat flow

$$Q = \frac{t_1 - t_2}{R}$$

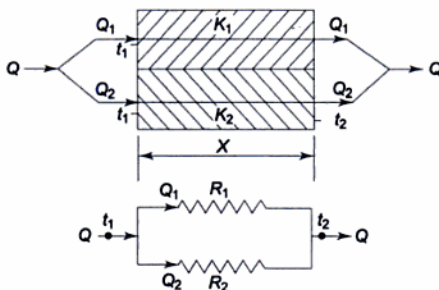

Fig. 18.5 Heat conduction through resistance in parallel

18.2.2 Heat Conduction through a Cylinder

Let us assume that the inside and outside surfaces of the cylinder (Fig. 18.6) are maintained at temperatures t_1 and t_2 respectively, and t_1 is greater than t_2 . We will also assume that heat is flowing, under steady state, only in the radial direction, and there is no heat conduction along the length or the periphery of the cylinder. The rate of heat transfer through the thin cylinder of thickness dr is given by

$$\begin{aligned} Q &= -KA \frac{dt}{dr} \\ &= -K 2 \pi r L \frac{dt}{dr} \end{aligned} \quad (18.3)$$

where L is the length of the cylinder.

$$\text{or} \quad \int_{t_1}^{t_2} dt = \int_{r_1}^{r_2} - \frac{Q}{2 \pi K L} \frac{dr}{r}$$

$$\therefore \quad t_2 - t_1 = - \frac{Q}{2 \pi K L} \ln \frac{r_2}{r_1}$$

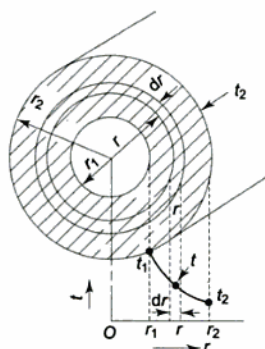

Fig. 18.6 Heat conduction through a cylindrical wall

$$\therefore Q = \frac{2\pi K L (t_1 - t_2)}{\ln \frac{r_2}{r_1}} \quad (18.4)$$

Equation (18.4) can also be written in the following form

$$\begin{aligned} Q &= \frac{2\pi L (r_2 - r_1) K (t_1 - t_2)}{(r_2 - r_1) \ln \frac{2\pi r_2 L}{2\pi r_1 L}} \\ &= \frac{K (A_2 - A_1) (t_1 - t_2)}{(r_2 - r_1) \ln \frac{A_2}{A_1}} \end{aligned}$$

where A_1 and A_2 are the inside and outside surface areas of the cylinder.

$$\therefore Q = -KA_{1.m.} \frac{t_2 - t_1}{r_2 - r_1} \text{ or } Q = -KA_{1.m.} \frac{t_2 - t_1}{x_w} \quad (18.5)$$

where $A_{1.m.} = \text{log-mean area} = \frac{A_2 - A_1}{\ln \frac{A_2}{A_1}}$

and $x_w = \text{wall thickness of the cylinder}$

$$= r_2 - r_1$$

Here the thermal resistance offered by the cylinder wall to radial heat conduction is

$$R = \frac{x_w}{K \cdot A_{1.m.}}$$

From Eq. (18.3)

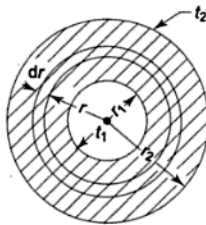

Fig. 18.8 Heat conduction through a sphere

where A is the spherical surface at radius r normal to heat flow,

$$\therefore Q = -K4\pi r^2 \frac{dt}{dr}$$

$$\int_{t_1}^{t_2} dt = \int_{r_1}^{r_2} -\frac{Q}{4\pi K} \frac{dr}{r^2}$$

$$t_2 - t_1 = -\frac{Q}{4\pi K} \left(\frac{1}{r_1} - \frac{1}{r_2} \right)$$

$$\therefore Q = \frac{4\pi K(t_1 - t_2)r_1 r_2}{r_2 - r_1}$$

$$\text{or } Q = -KA_{\text{g.m.}} \frac{t_2 - t_1}{x_w} \quad (18.7)$$

where $A_{\text{g.m.}}$ = geometrical mean area

$$\begin{aligned} &= \sqrt{A_1 A_2} = \sqrt{4\pi r_1^2 4\pi r_2^2} \\ &= 4\pi r_1 r_2 \end{aligned}$$

and x_w = wall thickness of the sphere

$$= r_2 - r_1$$

Here the thermal resistance offered by the wall to heat conduction is

$$R = \frac{x_w}{KA_{\text{g.m.}}}$$

Thus similar expressions of thermal resistance hold good for flat plate, cylinder, and sphere, which are

$$R_{\text{plate}} = \frac{x_w}{KA}, R_{\text{cylinder}} = \frac{x_w}{KA_{1.m.}} \text{ and}$$

$$R_{\text{sphere}} = \frac{x_w}{KA_{\text{g.m.}}}$$

where K is the thermal conductivity of the wall material.

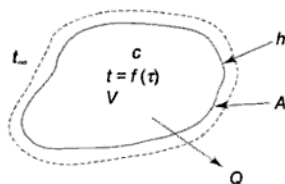

Fig. 18.11 Cooling of a solid by convection

Therefore,

Heat lost by the solid by convection = Decrease in internal energy of the solid

$$h A(t - t_{\infty}) = -\rho c V \frac{dt}{d\tau} \quad (18.13)$$

where t is the temperature of the solid, t_{∞} is the stream temperature of the ambient atmosphere, A is the surface area of the solid, ρ is the density, c is the specific heat, V is the volume and τ is the time.

If the solid is initially at t_0 , we have,

$$t = t_0 \text{ at } \tau = 0$$

Integration of Eq. (18.13) gives

$$\frac{t - t_{\infty}}{t_0 - t_{\infty}} = e^{-(h A \tau)/\rho c V} \quad (18.14)$$

If we use dimensionless numbers, viz., Biot number (Bi) and Fourier number (FO) defined as:

$$Bi = \frac{hL}{K} \text{ and } FO = \frac{\alpha\tau}{L^2}$$

where L = characteristic length = V/A and α = thermal diffusivity of the solid = $K/\rho c$.

Equation (18.14) becomes

$$\frac{t - t_{\infty}}{t_0 - t_{\infty}} = e^{-Bi FO} \quad (18.15)$$

This lumped-capacity is applicable when the conduction resistance is small compared to the convection resistance. In practice, this normally applies when

$$\frac{hL}{K} \text{ or } Bi < 0.1 \quad (18.16)$$

Equation (18.14) can also be expressed in terms of a thermal resistance for convection, $R_{th} = 1/hA$, and a thermal capacitance, $C_{th} = \rho cV$, so that

$$\frac{hA}{\rho cV} = \frac{1}{R_{th} C_{th}}$$

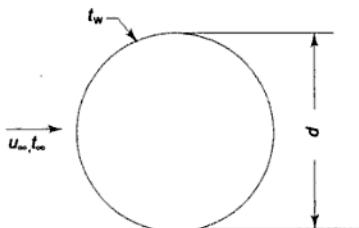

Fig. 18.17 (c) Flow across a cylinder

Re_d	c	n
0.4 - 4	0.989	0.330
4 - 40	0.911	0.385
40 - 4000	0.683	0.466
4000 - 40000	0.193	0.618
40000 - 400000	0.0266	0.805

For flow across a sphere, constant wall temperature:

$$\begin{aligned} \text{Gases:} & \quad Nu_d = 0.37 Re_d^{0.6} \\ \text{Water and Oil:} & \quad Nu_d = [1.2 + 0.53 Re_d^{0.54}] Pr^{0.3} \end{aligned} \quad (18.24)$$

Free convection

Let a fluid at T_o , with density ρ_o , change to temperature T with density ρ .

$$\text{Then the buoyancy force, } F = \frac{(\rho_o - \rho) g}{\rho}$$

Now, let β = coefficient for volume expansion

$$\text{then} \quad \frac{1}{\rho} = \frac{1}{\rho_o} + \beta(T_o - T)$$

$$\text{or} \quad \rho_o = \rho(1 + \beta \cdot \Delta T)$$

$$\therefore \quad F = \beta \cdot g \cdot \Delta T$$

$$\text{where} \quad \Delta T = T_o - T$$

For an ideal gas

$$\beta = \frac{1}{v} \left(\frac{\partial v}{\partial T} \right)_p = \frac{1}{v} \cdot \frac{R}{p} = \frac{1}{T} \quad (K^{-1})$$

The heat transfer coefficient in free convection may be assumed to be a function of the variables as given below

$$h = f(L, K, c_p, \rho, \mu, g \beta \Delta T)$$

By dimensional analysis, the above variables may be arranged in three non-dimensional groups

$$\frac{hL}{K} = B \left(\frac{g\beta\Delta T \cdot L^3 \cdot \rho^2}{\mu^2} \right)^a \cdot \left(\frac{\mu c_p}{K} \right)^b$$

or

$$\text{Nu} = B \cdot \text{Gr}^a \cdot \text{Pr}^b$$

where

$$\text{Nu} = \text{Nusselt number} = \frac{hL}{K}$$

$$\text{Gr} = \text{Grashof number} = \frac{g\beta\Delta T L^3 \rho^2}{\mu^2}$$

$$\text{Pr} = \text{Prandtl number} = \frac{\mu c_p}{K}$$

For a large number of experiments made on fluids it has been found that exponents a and b are of the same value. So the expression reduces to

$$\text{Nu} = B \cdot (\text{Gr} \cdot \text{Pr})^a \quad (18.25)$$

L is the characteristic length, which is the length in the case of a vertical plate and cylinder, diameter in the case of a horizontal cylinder, and radius in the case of a sphere.

For $\text{Gr} \cdot \text{Pr} < 10^9$, the flow is laminar, and

$$\text{Nu} = 0.59 (\text{Gr} \cdot \text{Pr})^{1/4} \quad (18.26)$$

and for $\text{Gr} \cdot \text{Pr} > 10^9$, the flow is turbulent, and

$$\text{Nu} = 0.13 (\text{Gr} \cdot \text{Pr})^{1/3} \quad (18.27)$$

18.4 Heat Exchangers

A heat exchanger is a device in which heat is transferred between two moving fluids.

Heat exchangers may be parallel flow, counterflow or crossflow, depending upon the direction of the motion of the two fluids. If both the fluids move in the same direction, it is a parallel flow heat exchanger. If the fluids flow in the opposite directions, it is a counterflow heat exchanger. If they flow normal to each other, it is a crossflow heat exchanger.

18.4.1 Parallel Flow Heat Exchanger

Let us assume that the cold fluid (subscript c) is flowing through the inner tube and the hot fluid (subscript h) is flowing through the annulus. The hot fluid enters at t_{h1} and leaves at t_{h2} , while the cold fluid enters at t_{c1} and leaves at t_{c2} . Let us consider a differential length dL of the heat exchanger, as shown in Fig. 18.18, where the hot fluid is at t_h and the cold fluid is at t_c , and the temperature difference between the two fluids is $\Delta t (= t_h - t_c)$. Δt varies from Δt_i at the inlet to Δt_e at the exit of the heat exchanger. Let dQ be the rate of heat transfer in that differential length. Then by energy balance.

$$\begin{aligned} \text{or} \quad & -\frac{d(\Delta t)}{\mu_p} = U_0 dA_0 \Delta t \\ \therefore \quad & -\int_{\Delta t_e}^{\Delta t_i} \frac{d(\Delta t)}{\Delta t} = \int_i^e \mu_p U_0 dA_0 \\ \therefore \quad & \ln \frac{\Delta t_i}{\Delta t_e} = \mu_p U_0 A_0 \end{aligned}$$

Substituting the expression for μ_p

$$\begin{aligned} \ln \frac{\Delta t_i}{\Delta t_e} &= \frac{\Delta t_i - \Delta t_e}{Q} \cdot U_0 A_0 \\ \therefore \quad Q &= \frac{\Delta t_i - \Delta t_e}{\ln \frac{\Delta t_i}{\Delta t_e}} U_0 A_0 \\ \text{where } \Delta t_i &= t_{h1} - t_{c1} \text{ and } \Delta t_e = t_{h2} - t_{c2} \\ \therefore \quad Q &= U_0 A_0 \Delta t_{l.m.} \\ &= \dot{m}_h c_h (t_{h1} - t_{h2}) \\ &= \dot{m}_c c_c (t_{c2} - t_{c1}) \end{aligned} \tag{18.28}$$

where $\Delta t_{l.m.}$ = log-mean temperature difference (LMTD)

$$= \frac{\Delta t_i - \Delta t_e}{\ln \frac{\Delta t_i}{\Delta t_e}}$$

$$\text{and} \quad \frac{1}{U_0 A_0} = \frac{1}{h_1 A_1} + \frac{x_w}{k_w A_{l.m.}} + \frac{1}{h_0 A_0}$$

18.4.2 Counterflow Heat Exchanger

The two fluids flow in opposite directions (Fig. 18.19). In the differential length, the rate of heat transfer

$$\begin{aligned} dQ &= -\dot{m}_h c_h dt_h \\ &= -\dot{m}_c c_c dt_c \\ &= U_0 \cdot dA_0 \cdot \Delta t \end{aligned}$$

where both dt_h and dt_c are negative for positive x direction (towards the right).
Now

$$\begin{aligned} \Delta t &= t_h - t_c \\ d(\Delta t) &= dt_h - dt_c \\ &= -\frac{dQ}{\dot{m}_h c_h} + \frac{dQ}{\dot{m}_c c_c} \end{aligned}$$

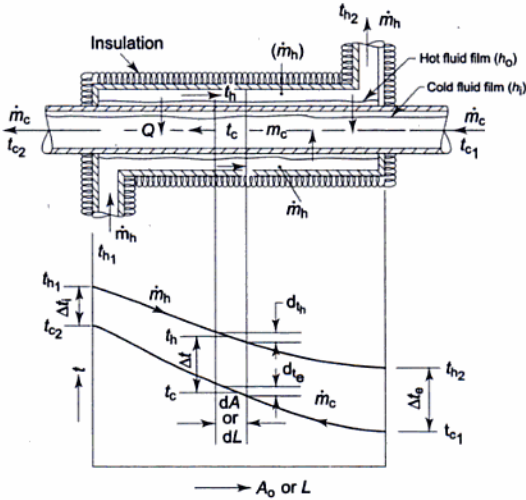

Fig. 18.19 Counterflow heat exchanger

$$= -dQ \left(\frac{1}{\dot{m}_h c_h} - \frac{1}{\dot{m}_c c_c} \right)$$

$$= -dQ \mu_c$$

where

$$\mu_c = \frac{1}{\dot{m}_h c_h} - \frac{1}{\dot{m}_c c_c}$$

$$\int_{\Delta t_i}^{\Delta t_e} d(\Delta t) = \int_i^e -dQ \cdot \mu_c$$

$$\Delta t_i - \Delta t_e = \mu_c \cdot Q$$

or

$$\mu_c = \frac{\Delta t_i - \Delta t_e}{Q}$$

Again

$$dQ = U_0 dA_0 \Delta t$$

$$-\frac{d(\Delta t)}{\mu_c} = U_0 \cdot dA_0 \cdot \Delta t$$

$$\int_{\Delta t_i}^{\Delta t_e} -\frac{d(\Delta t)}{\Delta t} = \int_i^e U_0 dA_0 \cdot \mu_c$$

$$\ln \frac{\Delta t_i}{\Delta t_e} = U_0 \cdot A_0 \cdot \mu_c = U_0 \cdot A_0 \cdot \frac{\Delta t_i - \Delta t_e}{Q}$$

∴

$$Q = U_0 A_0 \Delta t_{l.m.}$$

where

$$\Delta t_{l.m.} = \frac{\Delta t_i - \Delta t_e}{\ln \frac{\Delta t_i}{\Delta t_e}}$$

$$\Delta t_i = t_{h1} - t_{c2}, \Delta t_e = t_{h2} - t_{c1}$$

$$\frac{1}{U_0 A_0} = \frac{1}{h_i A_i} + \frac{x_w}{k_w A_{l.m.}} + \frac{1}{h_o A_o}$$

and when x_w is small,

$$\frac{1}{U_0} \cong \frac{1}{h_i} + \frac{x_w}{K_w} + \frac{1}{h_o}$$

\therefore

$$Q = U_0 A_0 \Delta t_{l.m.} = \dot{m}_h c_h (t_{h1} - t_{h2}) = \dot{m}_c c_c (t_{c2} - t_{c1}) \quad (18.29)$$

For the same rate of heat transfer, and inlet and exit temperatures, ($\Delta t_{l.m.}$) counterflow is greater than ($\Delta t_{l.m.}$) parallel flow. So the surface area required is less for counterflow operation. For parallel flow, $t_{h2} > t_{c2}$, i.e., the hot fluid cannot be cooled below t_{c2} or the cold fluid cannot be heated above t_{h2} . But for counterflow operation, t_{h2} may be less than t_{c2} which means that the hot fluid can be cooled below t_{c2} or the cold fluid heated above t_{h2} . For these reasons, counterflow heat exchangers are much more common in practice.

When one of the two fluids undergoes phase change (at constant temperature and pressure), e.g., condensation and evaporation, $\Delta t_{l.m.}$ is the same for parallel flow and counterflow (Fig. 18.20), and the heating surface required is also the same.

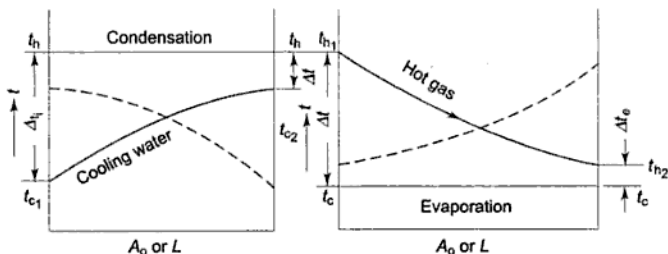

Fig. 18.20 Heat transfer with phase change

18.4.3 ϵ -NTU Method

In a heat exchanger, the rate of heat transfer

$$Q = \dot{m}_h c_h [t_{h1} - t_{h2}] = \dot{m}_c m_c [t_{c2} - t_{c1}] = U_0 A_0 \Delta t_{l.m.}$$

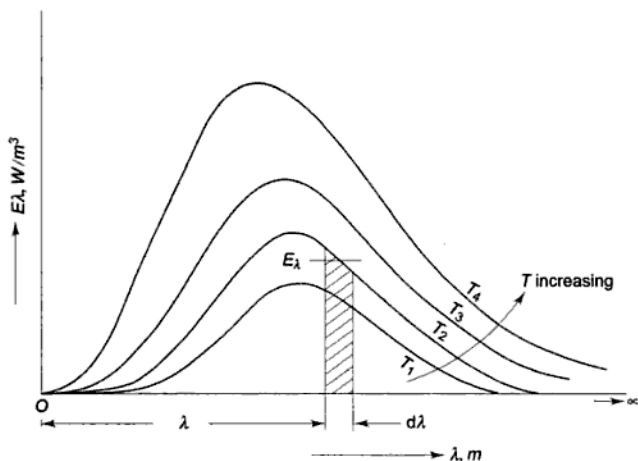

Fig. 18.21 Radiation intensity $E\lambda$ varying with λ and T .

where \dot{m}_h , c_h , \dot{m}_c , c_c , t_{h1} , t_{c1} and U_0 are usually given. Two tasks are mostly encountered:

1. To estimate the surface area required (A_0).
Then either t_{c2} or t_{h2} is given. We can use the LMTD method to find A_0 .
2. For a given heat exchanger (i.e. A_0), to estimate the exit temperature t_{h2} and t_{c2} .

We cannot find t_{h2} and t_{c2} directly by the LMTD method. We have to use trial-and-error method. Assume t_{c2} , find Q , t_{h2} , $\Delta T_{l.m.}$ and then Q' . If $Q' \neq Q$, assume another t_{c2} and repeat calculations till $Q' = Q$.

ϵ -NTU method can here be easily used. We introduce three terms in this regard.

$$(a) \text{ Heat capacity ratio, } R = \frac{(\dot{m}c)_s}{(\dot{m}c)_l} = \frac{C_{\min}}{C_{\max}}, (< 1)$$

where $(\dot{m}c)_s$ = smaller value of $\dot{m}_h c_h$ and $\dot{m}_c c_c = C_{\min}$

and $(\dot{m}c)_l$ = larger value of the two $\dot{m}_h c_h$ and $\dot{m}_c c_c = C_{\max}$

$$(b) \text{ Effectiveness, } \epsilon = \frac{\text{Actual heat transfer}}{\text{Maximum possible heat transfer}}$$

In a counterflow heat exchanger, e.g., $(t_{h2})_{\min} = t_{c1}$ or $(t_{c2})_{\max} = t_{h1}$.

$$\therefore \epsilon = \frac{\dot{m}_h c_h (t_{h1} - t_{h2})}{(\dot{m}c)_s (t_{h1} - t_{c1})} = \frac{\dot{m}_c c_c (t_{c2} - t_{c1})}{(\dot{m}c)_s (t_{h1} - t_{c1})} (< 1)$$

When one of the two fluids undergoes phase change, $R = 0$. Then,

$$\epsilon_p = \epsilon_c = 1 - e^{-NTU} \quad (18.33)$$

For a *balanced* heat exchanger, $\dot{m}_h c_h = \dot{m}_c c_c$,

\therefore

$$R = 1, \Delta t_i = \Delta t_e = \Delta t_{l.m.}$$

$$t_{h1} - t_{h2} = t_{c2} - t_{c1} \text{ or, } t_{h2} - t_{c1} = t_{h1} - t_{c2}$$

$$U_0 A_0 \Delta t_{l.m.} = U_0 A_0 (t_{h1} - t_{c2}) = \dot{m}_h c_h (t_{h1} - t_{h2})$$

$$= (\dot{m}c)_s (t_{h1} - t_{h2})$$

$$NTU = \frac{U_0 A_0}{(\dot{m}c)_s} = \frac{t_{h1} - t_{h2}}{t_{h1} - t_{c2}}$$

$$\epsilon = \frac{t_{h1} - t_{h2}}{t_{h1} - t_{c1}} = \frac{t_{h1} - t_{h2}}{(t_{h1} - t_{h2}) + (t_{h2} - t_{c1})}$$

$$= \frac{NTU(t_{h1} - t_{c2})}{NTU(t_{h1} - t_{c2}) + (t_{h1} - t_{c2})} = \frac{NTU}{NTU + 1} \quad (18.34)$$

18.5 Radiation Heat Transfer

All bodies radiate heat. The phenomenon is identical to the emission of light. Two similar bodies isolated together in a vacuum radiate heat to each other, but the colder body will receive more heat than the hot body and thus become heated.

If Q is the total radiant energy incident upon the surface of a body some part of it (Q_a) will be absorbed, some (Q_r) will be reflected, and some (Q_t) will be transmitted through the body. Therefore,

$$Q = Q_a + Q_r + Q_t$$

$$\text{or} \quad \frac{Q_a}{Q} + \frac{Q_r}{Q} + \frac{Q_t}{Q} = 1$$

$$\text{or} \quad \alpha + \rho + \tau = 1$$

where α is known as *absorptivity*, ρ as *reflectivity*, and τ as *transmissivity*. For an *opaque* body, $\tau = 0$ and $\alpha + \rho = 1$. Most solids are opaque.

A body which absorbs all the incident radiation is called a *black body*. A black body is also the best radiator. Most radiating surfaces are grey and have an emissivity factor ϵ less than unity, where

$$\epsilon = \frac{\text{Actual radiation of gray body at } T \text{ K}}{\text{Radiation of a black body at } T \text{ K}}$$

It can be shown that the *emissivity* or ability to radiate heat is equal to the *absorptivity* or ability to absorb heat (Kirchhoff's law), which justifies the statement that good absorbers are also good emitters. A brightly polished surface will have a low absorptivity and low emissivity.

The rate at which energy is radiated by a black body at temperature T (K) is given by a *Stefan-Boltzmann law*

$$Q = \sigma AT^4$$

where Q = rate of energy radiation, W

A = surface area radiating heat, m^2

and σ = Stefan-Boltzmann constant = $5.67 \times 10^{-8} \text{ W/m}^2 \text{ K}^4$

If the radiation from a heated body is dispersed into a spectrum by a prism, it is found that the radiant energy is distributed among various wave lengths. The *total emissive power* of a body, E , is defined as the total energy emitted by the body at a certain temperature per unit time and per unit surface area at all wave-lengths. The *monochromatic emissive power*, E_λ , is defined as the radiant energy emitted by a body per unit time and per unit surface area at a particular wavelength and temperature. The variation of E_λ and λ and T is shown in Fig. 18.21. At a certain temperature,

$$E = \int_0^{\infty} E_\lambda d\lambda \quad (18.35)$$

= Area under the curve at that temperature.

Thermal radiation extends over a spectral range of wavelengths from $0.1 \mu\text{m}$ to $100 \mu\text{m}$ and the spectral energy distribution of a black body is given by Planck's law:

$$E_{\lambda B} = \frac{C_1 \lambda^{-5}}{e^{C_2/\lambda T} - 1} \quad (18.36)$$

where λ = wavelength, μm ; T = temperature, K;

$C_1 = 3.743 \times 10^8 \text{ W.} (\mu\text{m})^4/\text{m}^2$; $C_2 = 1.4387 \times 10^4 \mu\text{m.K.}$

$E_{\lambda B}$ is called the monochromatic emissive power of a black body. The *emissivity* of a surface is then:

$$\varepsilon = \frac{E}{E_B} \quad (18.37)$$

where E_B is the total emissive power of a black body. A *gray body* has the *monochromatic emissivity*, ε_λ , constant over all wavelengths.

$$\varepsilon_\lambda = \frac{E_\lambda}{E_{\lambda B}} = \text{constant for a gray body} \quad (18.38)$$

Real surfaces are not gray and have a jagged emissive power distribution as shown in Fig. 18.22.

The actual radiant energy transfer between two bodies depends upon the (i) two surface temperatures, (ii) the surface emissivities, and (iii) the geometric orientation of the surfaces, i.e., how they view each other. A *radiation shape factor* F_{12} (or view factor) is defined as the fraction of energy leaving surface 1

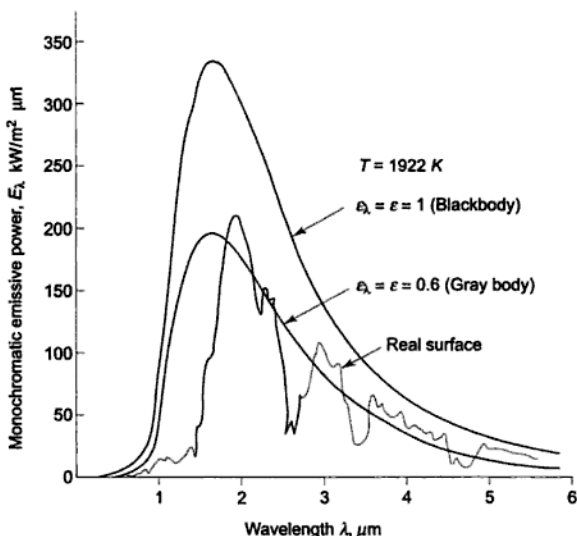

Fig. 18.22 Comparison of ideal blackbody, gray body and real surface

and reaching surface 2. Similarly, F_{21} is the fraction of energy leaving 2 and reaching 1. It can be shown that

$$A_1 F_{12} = A_2 F_{21} \quad (18.39)$$

which is known as the *reciprocity theorem*.

The total emissive power of a black body is given by:

$$E_B = \int_0^{\infty} E_{\lambda B} d\lambda = \int_0^{\infty} \frac{C_1 \lambda^{-5}}{e^{C_2/\lambda T} - 1} d\lambda = \sigma T^4$$

which is the Stefan-Boltzmann law, as stated earlier.

Charts of F_{12} for three geometries are shown in Figs 18.23, 18.24 and 18.25.

In estimating radiant heat transfer from gray surfaces, two terms will be introduced.

Radiosity (J) = total energy leaving a surface per unit area and per unit time (sum of emitted and reflected energies)

Irradiation (G) = total energy incident on a surface per unit area and per unit time.

The energy balance for the gray body (Fig. 18.26) assumed to be opaque ($\tau = 0$) gives:

$$J = \epsilon E_B + \rho G = \epsilon E_B + (1 - \epsilon)G$$

$$G = [J - \epsilon E_B]/[1 - \epsilon]$$

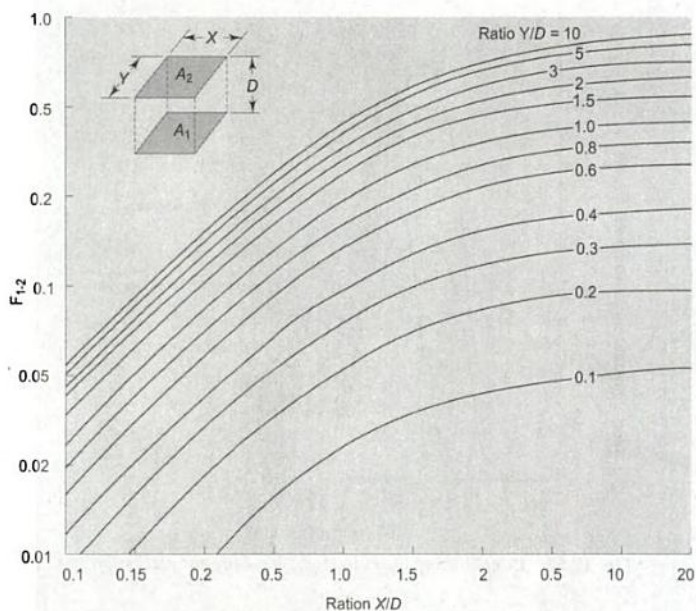

Fig. 18.23 Radiation shape factor for radiation between parallel rectangles

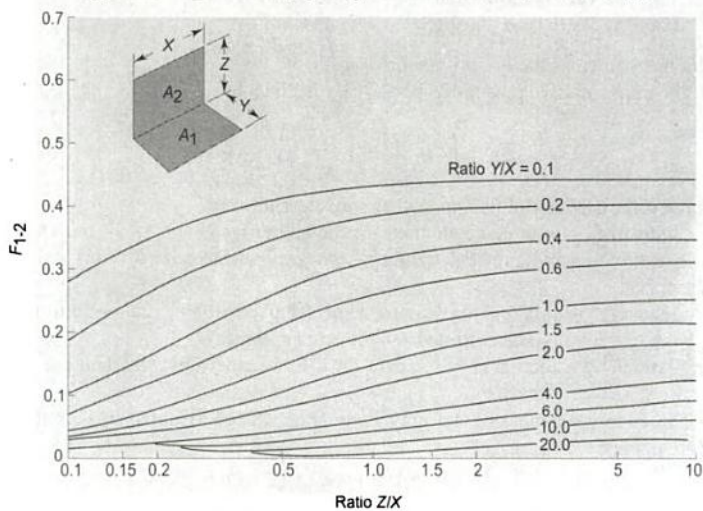

Fig. 18.24 Radiation shape factor for radiation between perpendicular rectangles with a common edge

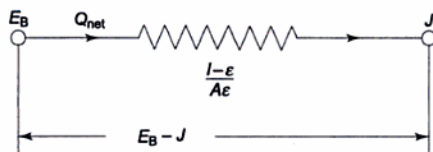

Fig. 18.27 Surface resistance in radiation network

Let us now consider the exchange of radiant energy by two surfaces A_1 and A_2 (Fig. 18.28). Of the total radiation which leaves the surface 1, the amount that reaches surface 2 is $J_1 A_1 F_{12}$, and of the total energy leaving surface 2, the amount that reaches surface 1 is $J_2 A_2 F_{21}$.

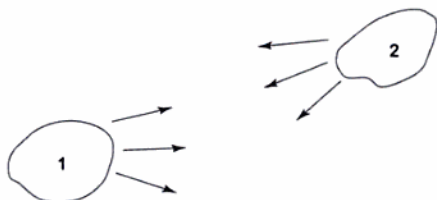

Fig. 18.28 Radiation interaction between two gray surfaces

The net energy interchange between two surface is:

$$\begin{aligned} Q_{1-2} &= J_1 A_1 F_{12} - J_2 A_2 F_{21} \\ &= (J_1 - J_2) A_1 F_{12} = \frac{J_1 - J_2}{1/(A_1 F_{12})} \end{aligned} \quad (18.41)$$

The denominator $1/(A_1 F_{12})$ is called the "space resistance" and the numerator $(J_1 - J_2)$ is the potential difference, as shown in Fig. 18.29.



Fig. 18.29 Space resistance in radiation network

Figure 18.30 shows a network which represents two surfaces exchanging radiative energy with each other.

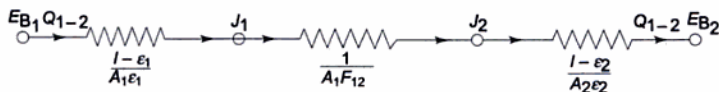

Fig. 18.30 Radiation network for two gray surfaces

Rate of heat transfer by radiation

$$Q_r = \sigma A_1 \mathcal{F}_{1-2} (T_w^4 - T_f^4) = h_r A_1 (t_w - t_f)$$

where h_r is known as the radiation heat transfer coefficient.

$$\therefore h_r = \sigma \mathcal{F}_{1-2} (T_w + T_f) (T_w^2 + T_f^2) \quad (18.48)$$

\therefore Total rate of heat transfer

$$Q = Q_c + Q_r = (h_c + h_r) A_1 (t_w - t_f) \quad (18.49)$$

SOLVED EXAMPLES

Example 18.1 A cold storage room has walls made of 0.23 m of brick on the outside, 0.08 m of plastic foam, and finally 1.5 cm of wood on the inside. The outside and inside air temperatures are 22°C and -2°C respectively. If the inside and outside heat transfer coefficients are respectively 29 and 12 W/m² K, and the thermal conductivities of brick, foam, and wood are 0.98, 0.02, and 0.17 W/mK respectively, determine (a) the rate of heat removed by refrigeration if the total wall area is 90 m², and (b) the temperature of the inside surface of the brick.

Solution Figure Ex. 18.1 shows the wall of the cold storage

$$\begin{aligned} \frac{1}{U} &= \frac{1}{h_o} + \frac{x_1}{k_1} + \frac{x_2}{k_2} + \frac{x_3}{k_3} + \frac{1}{h_i} \\ &= \frac{1}{12} + \frac{0.23}{0.98} + \frac{0.08}{0.02} + \frac{1.5}{100 \times 0.17} + \frac{1}{29} \\ \frac{1}{U} &= 0.0833 + 0.2347 + 4.0 + 0.0882 + 0.0345 \\ &= 4.4407 \text{ m}^2 \text{ K/W} \end{aligned}$$

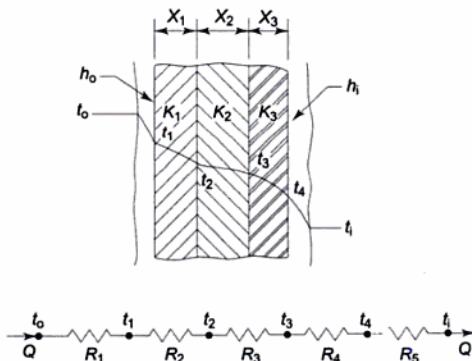

Fig. Ex. 18.1

$$= \frac{6.28 \times 50 \times 35}{0.3448 + 0.7092 + 0.3448 + 0.6410} = 2334 \text{ W}$$

$$= 2.334 \text{ kW} \quad \text{Ans.}$$

Example 18.3 Three 10 mm dia. rods A , B and C protrude from a steam path at 100°C to a length of 0.25 m into the atmosphere at 20°C . The temperatures of the other ends are found to be 26.76°C for A , 32.00°C for B and 36.93°C for C . Neglecting the effects of radiation and assuming the surface film coefficient of $23 \text{ W/m}^2\text{K}$, evaluate their thermal conductivities.

Solution If the tip loss is neglected, the tip temperature t_1 is given by

$$\frac{t_1 - t_\infty}{t_1 - t_\infty} = \frac{1}{\cosh ml}$$

For rod A ,

$$\frac{26.76 - 20}{100 - 20} = \frac{6.76}{80} = \frac{1}{\cosh ml}$$

$$\cosh ml = 11.8$$

or,

$$ml = 3.16$$

$$m = \frac{3.16}{0.25} = 12.64 \text{ m}^{-1} = \left[\frac{hp}{KA} \right]^{1/2}$$

Here,

$$P = \pi d \text{ and } A = \frac{\pi}{4} d^2$$

$$\frac{23 \times \pi \times 0.01 \times 4}{K \times \pi \times 0.01 \times 0.01} = (12.64)^2$$

$$K_A = 57.58 \text{ W/mK}$$

Ans.

For rod B ,

$$\frac{32 - 20}{100 - 20} = \frac{12}{80} = \frac{1}{\cosh ml}$$

$$\cosh ml = 6.67$$

$$ml = 2.6$$

or,

$$m = \frac{2.6}{0.25} = 10.4 = \left[\frac{23 \times \pi \times 0.01 \times 4}{K \times \pi \times 0.01 \times 0.01} \right]^{1/2}$$

$$K_B = \frac{9200}{(10.4)^2} = 85.2 \text{ W/mK}$$

Ans.

For rod C ,

$$\frac{1}{\cosh ml} = \frac{36.93 - 20}{100 - 20} = \frac{16.93}{80}$$

$$\cosh ml = 4.73$$

or,

$$ml = 2.23$$

or,

$$m = 2.23/0.25 = 8.92$$

in 30 min? The peas are supposed to have an average dia. of 8 mm. Their density is 750 kg/m^3 and specific heat 3.35 kJ/kgK .

Solution From Eq. (18.14)

$$\frac{t - t_{\infty}}{t_0 - t_{\infty}} = e^{-(hA\tau)/(\rho cV)}$$

Here,

$$\frac{\rho V}{A} = \frac{750 \times 4\pi (d/2)^3}{3 \times 4\pi (d/2)^2} = \frac{750}{3} \times \frac{d}{2} = \frac{750}{3} \times \frac{0.008}{2} = 1$$

$$\ln \frac{2-1}{25-1} = -\frac{hA\tau}{\rho cV} = -\frac{h\tau}{c} = -\frac{5.8 \times 10^{-3} \tau}{3.35}$$

$$\ln 24 = \frac{5.8 \times 10^{-3} \times 3600 \tau}{3.35}$$

$$\tau = 0.51 \text{ h} = 31 \text{ min} \quad \text{Ans. (a)}$$

$$(b) \quad \frac{t-1}{25-1} = e^{-(5.8 \times 10^{-3} \times 10 \times 60)/3.5}$$

$$\tau = 9.5^\circ\text{C} \quad \text{Ans. (b)}$$

$$(c) \quad \frac{5-t_{\infty}}{25-t_{\infty}} = e^{-(5.8 \times 10^{-3} \times 30 \times 60)/3.35}$$

$$t_{\infty} = 4.1^\circ\text{C} \quad \text{Ans. (c)}$$

Example 18.6 An oil cooler for a lubrication system has to cool 1000 kg/h of oil ($c_p = 2.09 \text{ kJ/kg K}$) from 80°C to 40°C by using a cooling water flow of 1000 kg/h available at 30°C . Give your choice for a parallel flow or counterflow heat exchanger, with reasons. Estimate the surface area of the heat exchanger, if the overall heat transfer coefficient is $24 \text{ W/m}^2 \text{ K}$ (c_p of water = 4.18 kJ/kg K).

Solution Rate of heat transfer

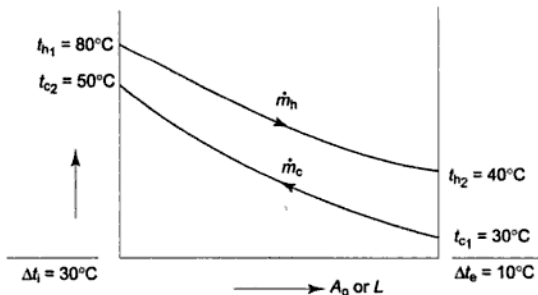

Fig. Ex. 18.6

Example 18.8 An oil fraction at 121°C is to be cooled at the rate of 20.15 kg/s in a simple counterflow heat exchanger using 5.04 kg/s of water initially at 10°C . The exchanger contains 200 tubes each 4.87 m long and 1.97 cm o.d., with $U_o = 0.34\text{ kW/m}^2\text{K}$. If the specific heat of oil is 2.094 kJ/kgK , calculate the exit temperature of the oil and the rate of heat transfer.

Solution

$$\dot{m}_h = 20.15\text{ kg/s}, c_h = 2.094\text{ kJ/kg K}, t_{h_1} = 121^\circ\text{C},$$

$$\dot{m}_c = 5.04\text{ kg/s}, c_c = 4.2\text{ kJ/kg K}, t_{c_1} = 10^\circ\text{C},$$

$$U_o = 0.34\text{ kW/m}^2\text{K}$$

$$A_o = n d_o l = 200 \times \pi \times 0.0197 \times 4.87 = 60.28\text{ m}^2$$

$$(\dot{m}c)_{\text{oil}} = 20.15 \times 2.094 = 42.19\text{ kW/K}$$

$$(\dot{m}c)_{\text{water}} = 5.04 \times 4.2 = 21.09\text{ kW/K}$$

$$C_{\min} = 21.09\text{ kW}; C_{\max} = 42.19\text{ kW/K}$$

$$R = \frac{C_{\min}}{C_{\max}} = \frac{21.09}{42.19} = 0.5$$

$$\text{NTU} = \frac{U_o A_o}{C_{\min}} = \frac{0.34 \times 60.28}{21.09} = 0.972$$

$$\varepsilon = \frac{1 - \exp[-\text{NTU}(1 - R)]}{1 - R \exp[-\text{NTU}(1 - R)]} = \frac{0.3849}{0.6925}$$

$$= 0.5558 = \frac{\Delta t_{\text{larger}}}{t_{h_1} - t_{c_1}}$$

$$\Delta t_{\text{larger}} = (\Delta T)_{\text{water}} = 0.5558 (121 - 10)$$

$$= 61.69^\circ\text{C}$$

$$\Delta t_{\text{oil}} = \frac{\Delta t_{\text{water}} \times (\dot{m}c)_{\text{water}}}{(\dot{m}c)_{\text{oil}}} = 30.84^\circ\text{C} = t_{h_1} - t_{h_2}$$

$$t_{h_2} = 121 - 30.84 = 90.16^\circ\text{C}$$

= exit temperature of oil.

Ans.

$$Q = \dot{m}_h c_h [t_{h_1} - t_{h_2}] = 42.19 \times 30.84$$

$$= 1308\text{ kW}$$

Ans.

Example 18.9 Water flows inside a tube 5 cm in diameter and 3 m long at a velocity 0.8 m/s . Determine the heat transfer coefficient and the rate of heat transfer if the mean water temperature is 50°C and the wall is isothermal at 70°C . For water at 60°C , take $K = 0.66\text{ W/mK}$, $\nu = 0.478 \times 10^{-6}\text{ m}^2/\text{s}$, and $\text{Pr} = 2.98$.

Solution Reynolds number,

$$\text{Re} = \frac{u_m D}{\nu} = \frac{0.8 \times 0.05}{0.478 \times 10^{-6}}$$

$$= 83,700$$

The flow is turbulent.

Prandtl number, $\text{Pr} = 2.98$

Solution

Referred to Fig. Ex. 18.12

$$A_1 = \pi d_1 = \pi \times 0.10 = 0.314 \text{ m}$$

$$A_2 = \pi d_2 = \pi \times 0.20 = 0.628 \text{ m}$$

$$\frac{1 - \epsilon_1}{A_1 \epsilon_1} = \frac{1 - 0.65}{0.314 \times 0.65} = 1.715$$

$$\frac{1 - \epsilon_2}{A_2 \epsilon_2} = \frac{1 - 0.4}{0.628 \times 0.4} = 2.39$$

$$\frac{1}{A_1 F_{12}} = \frac{1}{0.314 \times 0.4} = 3.19$$

$$\sum R = \frac{1 - \epsilon_1}{A_1 \epsilon_1} + \frac{1}{A_1 F_{12}} + \frac{1 - \epsilon_2}{A_2 \epsilon_2}$$

$$= 1.715 + 2.39 + 3.19 = 7.295$$

$$E_{B_1} = \sigma T_1^4 = 5.67 \times 10^{-8} \times (1000)^4 = 5.67 \times 10^4 \text{ W/m}^2$$

$$E_{B_2} = \sigma T_2^4 = 5.67 \times 10^{-8} \times (500)^4 = \frac{5.67 \times 10^4}{16}$$

$$= 0.35 \times 10^4 \text{ W/m}^2$$

$$Q = \frac{E_{B_1} - E_{B_2}}{\sum R} = \frac{5.32 \times 10^4}{7.295} = 0.729 \times 10^4$$

$$= 7290 \text{ W/m length}$$

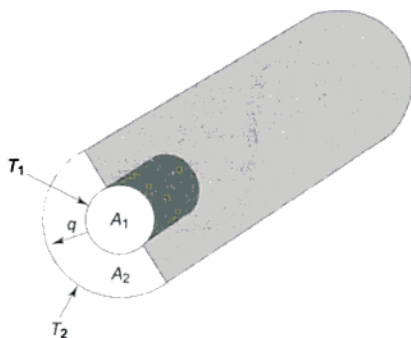
Ans.**Fig. Ex. 18.12****REVIEW QUESTIONS**

- 18.1 How is the subject of Heat Transfer different from the subject of Thermodynamics?

- 18.2 What are the three basic modes in which heat is transferred?
- 18.3 Why are good electrical conductors also good thermal conductors?
- 18.4 What is Fourier's law of heat conduction?
- 18.5 How does the slope of the temperature profile in a wall depend on its thermal conductivity?
- 18.6 Show that, for estimating radial heat conduction through a cylindrical wall, the log-mean area of the inner and outer surfaces h_c to be considered.
- 18.7 Show that for estimating radial heat conduction through a spherical wall, the geometric mean area of the inner and outer surfaces should be considered.
- 18.8 How do fins affect the heat transfer rate?
- 18.9 How is fin efficiency defined?
- 18.10 What is meant by transient heat conduction?
- 18.11 What is lumped-capacity analysis?
- 18.12 What are Biot number and Fourier number? What is their physical significance?
- 18.13 What do you understand by natural convection and forced convection?
- 18.14 How is heat transfer coefficient defined. What is its dimension?
- 18.15 What are the three resistances offered to heat transfer from one fluid to another through a clean wall?
- 18.16 What is Reynolds number? What is its critical value when the flow through a tube becomes turbulent?
- 18.17 What are Prandtl number and Nusselt number?
- 18.18 For fully developed laminar flow in a tube, what are the values of Nusselt number (a) for constant wall temperature, (b) for constant wall heat flux?
- 18.19 What are the expressions of Nusselt number for (a) laminar flow and (b) turbulent flow, over a flat plate?
- 18.20 What is Dittus-Boelter equation? Where is it used?
- 18.21 What is Grashof number? When does it become significant?
- 18.22 What is a heat exchanger?
- 18.23 Why are counterflow heat exchangers superior to parallel flow heat exchangers?
- 18.24 What is log-mean temperature difference?
- 18.25 Why do the directions of flows of the two fluids in a heat exchanger become immaterial when one of the two fluids undergoes phase change?
- 18.26 When is ϵ -NTU method convenient to use in heat exchanger analysis?
- 18.27 Define (a) effectiveness, (b) heat capacity ratio and (c) NTU, in regard to a heat exchanger.
- 18.28 Derive the expression for effectiveness in a (a) parallel flow heat exchanger, (b) counter-flow heat exchanger.
- 18.29 What is the expression for effectiveness when one of the fluids undergoes phase change?
- 18.30 Find the expression for effectiveness of a balanced heat exchanger with equal heat capacities.
- 18.31 Define absorptivity, reflectivity and transmissivity.
- 18.32 What is emissivity? What is Kirchhoff's law?
- 18.33 What is a black body?
- 18.34 What is the Stefan-Boltzmann law?
- 18.35 What is the view factor? Why is it significant in radiant heat exchange between two bodies?
- 18.36 What is the reciprocity theorem?

- 18.37 What is a gray body?
 18.38 What are meant by (a) monochromatic emissive power, (b) total emissive power?
 18.39 What is Planck's law of thermal radiation? Explain its importance.
 18.40 Define radiosity and irradiation for a gray body.
 18.41 Explain (a) surface resistance and (b) space resistance in radiant energy change between two gray bodies.
 18.42 Give the radiation network for two gray surfaces and derive the view factor.
 18.43 What do you mean by "floating node"?
 18.44 How would you define the heat transfer coefficient for combined convection and radiation?

PROBLEMS

- 18.1 A room has a brick wall 25 cm in thickness. The inside air is at 25°C and the outside air is at -15°C. The heat transfer coefficients on the inside and outside are 8.72 and 28 W/m² K respectively. The thermal conductivity of brick is 0.7 W/mK. Find the rate of heat transfer through the wall and the inside surface temperature.
- 18.2 For the wall in the above problem, it is proposed to reduce the heat transfer by fixing an insulating board ($K = 0.05$ W/mK), 2.5 cm in thickness, to the inside surface. Find the rate of heat transfer and the inside surface temperature.
- 18.3 Sheets of brass and steel, each 1 cm thick, are placed in contact. The outer surface of brass is kept at 100°C and the outer surface of steel is kept at 0°C. What is the temperature of the common interface? The thermal conductivities of brass and steel are in the ratio 2:1.
- Ans.* 66.7°C
- 18.4 In a pipe carrying steam, the outside surface (15 cm OD) is at 300°C. The pipe is to be covered with insulation ($K = 0.07$ W/mK) such that the outside surface temperature does not exceed 60°C. The atmosphere is at 25°C and the heat transfer coefficient is 11.6 W/m² K. Find the thickness of insulation required and the rate of heat loss per m length of pipe.
- 18.5 The passenger compartment of a jet transport is essentially a cylindrical tube of diameter 3 m and length 20 m. It is lined with 3 cm of insulating material ($K = 0.04$ W/mK), and must be maintained at 20°C for passenger comfort although the average outside temperature is -30°C at its operating height. What rate of heating is required in the compartment, neglecting the end effects?
- 18.6 A hollow sphere ($K = 35$ W/mK), the inner and outer diameters of which are 28 cm and 32 cm respectively, is heated by means of a 20 ohm coil placed inside the sphere. Calculate the current required to keep the two surfaces at a constant temperature difference of 50°C, and calculate the rate of heat supply.
- 18.7 (a) Develop an expression for the steady state heat transfer rate through the walls of a spherical container of inner radius r_i and outer radius r_o . The temperatures are t_o and t_i at radii r_o and r_i respectively. Assume that the thermal conductivity of the wall varies as

$$K = K_0 + (K_1 - K_0) \frac{t - t_0}{t_1 - t_0}$$

initial temperature of the ball was 65°C and in 1.15 min the temperature decreased by 11°C . Calculate the heat transfer coefficient for this case.

[Ans. $37.41 \text{ W/m}^2\text{K}$]

- 18.21 A cubical piece of aluminium 1 cm on a side is to be heated from 50°C to 300°C by a direct flame. How long should the aluminium remain in the flame, if the flame temperature is 800°C and the convective heat transfer coefficient is $190 \text{ W/m}^2\text{K}$? For aluminium, take $\rho = 2719 \text{ kg/m}^3$ and $c = 0.871 \text{ kJ/kgK}$.

[Ans. 8.36 s]

- 18.22 The cooling system of an electronic package has to dissipate 0.153 kW from the surface of an aluminium plate $100 \text{ mm} \times 150 \text{ mm}$. It is proposed to use 8 fins, each 150 mm long and 1 mm thick. The temperature difference between the plate and the surroundings is 50 K , the thermal conductivity of the plate and fins is 0.15 kW/mK and the convective coefficient is $0.04 \text{ kW/m}^2\text{K}$. Calculate the height of fins required.

[Ans. 30 cm]

- 18.23 Oil ($c_p = 2 \text{ kJ/kgK}$) is cooled from 110°C to 70°C by a flow of water in a counterflow heat exchanger. The water ($c_p = 4.18 \text{ kJ/kgK}$) flows at the rate of 2 kg/s and is heated from 35°C to 65°C . The overall heat transfer coefficient is $0.37 \text{ kW/m}^2\text{K}$. Determine the exit temperatures of oil and water, if the water flow rate drops to 1.5 kg/s at the same oil flow rate.

[Ans. 72.5°C , 72.5°C]

- 18.24 A tank contains 272 kg of oil which is stirred so that its temperature is uniform. The oil is heated by an immersed coil of pipe 2.54 cm dia. in which steam condenses at 149°C . The oil of specific heat 1.675 kJ/kgK is to be heated from 32.2°C to 121°C in 1 hour. Calculate the length of pipe in the coil if the surface coefficient is $0.653 \text{ kW/m}^2\text{K}$.

[Ans. 3.47 m]

Statistical Thermodynamics

The classical mechanics of Newton is quite successful in predicting the behaviour of large particles. But when it is applied to microscopic particles, it is found to be at odds with some observed phenomena. With the concept of classical mechanics, it is not possible to explain the experimental fact that the specific heats of a substance tend to zero as temperature approaches zero. These discrepancies of classical mechanics are resolved when the energies of the particles are assumed to be quantized according to the principles of quantum mechanics.

19.1 Quantum Hypothesis

Till the advent of the twentieth century, it was thought that microscopic particles could possess any value of energy. Application of this principle to the emission of radiant energy from an isothermal enclosure led to predictions which were at variance with measurements. The theories of thermal radiation proposed by Wien, Rayleigh and Jeans were found to be inadequate. The agreement of theory with experiment was achieved by Planck with his quantum theory of radiation in which he postulated that energy is emitted and absorbed by a heated enclosure in small quanta, called *photons*, and there is a definite frequency associated with each quantum of energy ϵ_0 given by

$$\epsilon_0 = h\nu \quad (19.1)$$

where h is a universal constant, known as *Planck's constant*, equal to 6.624×10^{-34} J-s. The energy of photon ϵ_0 is thus proportional to its frequency. According to Planck's theory, ν can have only definite and discrete values. In other words, the energy of a photon cannot have any value between zero and infinity, but discrete values like $0, \epsilon_0, 2\epsilon_0, 3\epsilon_0, \dots, n\epsilon_0$, where n is the quantum number.

In the atomic model, the quantum theory applies. The atom can exist in a number of energy states. In a gas like hydrogen, when its atom is heated, the

electrons jump to higher orbits, and when cooled, the electrons come down to lower orbits, each orbit representing a certain energy value of the atom. All the orbits are, however, not available to the electron. Only those orbits are allowed which, according to Bohr-Sommerfeld rule, satisfy the action integral:

$$\oint p \, dq = n h, \quad (19.2)$$

where p is the momentum and q , the corresponding coordinate of the electron (e.g., $p_x dx$ or $p_\theta d\theta$), and n is an integer (1, 2, 3, ...). The integration is to be done for one cycle of closed path. For a gas like hydrogen, the Eq. (19.2) yields:

$$\begin{aligned} I\omega \cdot 2\pi &= n h \\ mr^2 \frac{v}{r} 2\pi &= n h \\ m v r &= I\omega = \frac{nh}{2\pi} \end{aligned} \quad (19.3)$$

where m is the mass of the electron, v its velocity, and r the radius of its orbit. The above equation states that the only possible circular orbits of the electron are those in which the angular momentum ($I\omega$) of the electron is a multiple of $h/2\pi$.

19.2 Quantum Principle Applied to a System of Particles

Let us consider a system of N particles of an ideal gas contained in a cubical box of side L . Let the mass of each of the identical particles be m . The particles are moving about with different velocities in the box and making only elastic collisions with the walls. Let us focus our attention on one of these particles moving with velocity v having three components v_x , v_y and v_z . From Eq. (19.2), for the x -component motion of the particle,

$$\oint m v_x \, dx = n_x h, \quad n_x = 1, 2, 3, \dots$$

or $m v_x 2L = n_x h$

or $v_x = n_x \frac{h}{2mL}$ (19.4)

where n_x is the quantum number in the x -direction. The discrete values of v_x are:

$$v_x = 1 \frac{h}{2mL}, 2 \frac{h}{2mL}, 3 \frac{h}{2mL} \text{ and so on.}$$

The permissible values for the speed are called *speed levels*. For a macroscopic body, say a marble of mass 2g in a cubical box of side 10 cm,

$$\begin{aligned} \frac{h}{2mL} &= \frac{6.624 \times 10^{-34} \text{ J-s}}{2 \times 2 \times 10^{-3} \text{ kg} \times 10 \times 10^{-2} \text{ m}} \\ &= 1.656 \times 10^{-30} \text{ m/s} \end{aligned}$$

which is a very small speed interval.

For a hydrogen atom of 3.3×10^{-24} g in the same box,

$$\frac{h}{2mL} = \frac{6.624 \times 10^{-34} \text{ J-s}}{2 \times 3.3 \times 10^{-27} \text{ kg} \times 10^{-1} \text{ m}} = 10^{-6} \text{ m/s}$$

This speed interval is relatively large. Hence, in the case of such a microscopic particle, the quantum view and the continuum view have different meanings. We may say that the continuum view is a special limiting case of the more general quantum view.

The kinetic energy of the particle in x -direction,

$$\epsilon_x = \frac{1}{2} m v_x^2 = \frac{1}{2} m n_x^2 \frac{h^2}{4mL^2}$$

or

$$\epsilon_x = n_x^2 \frac{h^2}{8mL^2} \quad (19.5)$$

The discrete set of permissible values of ϵ_x is:

$$\epsilon_x = 1 \frac{h^2}{8mL^2}, 4 \frac{h^2}{8mL^2}, 9 \frac{h^2}{8mL^2} \text{ and so on.}$$

Each of these energy values is called an *energy level*. A particle is said to occupy an energy level when it has one of these values.

Similarly, in y and z directions,

$$\epsilon_y = n_y^2 \frac{h^2}{8mL^2} \quad \text{and} \quad \epsilon_z = n_z^2 \frac{h^2}{8mL^2}$$

where n_y and n_z are the quantum numbers in the y and z directions respectively. Therefore, the discrete values of the total kinetic energy of a particle are:

$$\begin{aligned} \epsilon &= \epsilon_x + \epsilon_y + \epsilon_z \\ &= (n_x^2 + n_y^2 + n_z^2) \frac{h^2}{8mL^2} \end{aligned} \quad (19.6)$$

In *velocity space* a spherical surface at a radius of velocity v is called a speed or velocity surface representing the energy level $\epsilon = mv^2/2$.

Permissible points on the speed surface represent *quantum states* belonging to this energy level. Since the velocity components are quantized, the tips of two components v_x and v_{x+1} are spaced by a distance of $h/(2mL)$. In the three dimensional space, each state occupies an exclusive volume, called a unit cell, of $(h/2mL)^3$. Within a spherical shell at radius v and of thickness dv , the number of quantum states dg is equal to the volume of the shell divided by the volume of the unit cell, or:

$$dg = \frac{\frac{1}{8} (4\pi v^2) dv}{[h/(2mL)]^3} = \frac{4\pi m^3 L^3}{h^3} v^2 dv \quad (19.7)$$

The factor $1/8$ is used because only the positive octant of velocity space is concerned, without distinguishing between v_x and $-v_x$.

In terms of energy,

$$v = [(2\varepsilon)/m]^{1/2}$$

or
$$dv = \frac{1}{2} \sqrt{\frac{2}{m}} \varepsilon^{-1/2} d\varepsilon$$

From Eq. (19.7),

$$\begin{aligned} dg &= \frac{4\pi m^3 L^3}{h^3} \frac{2\varepsilon}{m} \frac{1}{2} \sqrt{\frac{2}{m}} \varepsilon^{-1/2} d\varepsilon \\ &= \frac{4\pi mV}{h^3} [2m\varepsilon]^{1/2} d\varepsilon \end{aligned} \quad (19.8)$$

where $V = L^3$, the volume of the box.

Here, dg represents the number of quantum states in the energy interval from ε to $\varepsilon + d\varepsilon$.

19.3 Wave-Particle Duality

When a collimated beam of light is projected through a pin-hole aperture on to a screen, one observes diffraction rings with the intensity distribution across the rings (Fig. 19.1). The diffraction phenomenon is due to the wave nature of light. Interference phenomena also confirm it. Again, there is the Compton effect in which a particle of light or photon strikes an electron and changes its trajectory. This exhibits the particle nature of light. Thus, the basic units of light, the photons, behave both like particles (of zero rest mass) and like waves.

When a *cathode ray*, consisting of an electron beam at very low pressure, produced by filament heated to a very high temperature (~ 2000 K), is accelerated to a potential difference and passed through a very thin metal foil ($\sim 0.1 \mu\text{m}$), and the electrons are collected on a photographic plate, it shows diffraction pattern

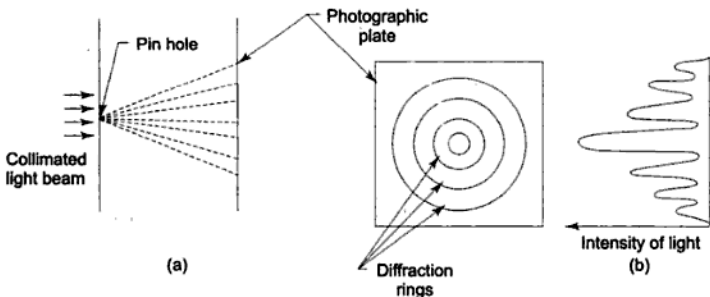

Fig. 19.1 Diffraction exhibits the wave nature of light

$$\frac{\partial^2 y}{\partial x^2} = \frac{m}{T} \frac{\partial^2 y}{\partial t^2}$$

$$\text{or} \quad \frac{\partial^2 y}{\partial x^2} = \frac{1}{V_p^2} \frac{\partial^2 y}{\partial t^2} \quad (19.12)$$

where V_p is the phase velocity equal to $(T/m)^{1/2}$ and y is the amplitude of vibration at time t at any distance x from the fixed end point.

To solve the above partial differential equation, the method of separation of variables will be employed.

$$\text{Let} \quad y = f(x) g(t)$$

where f is a function of x only and g a function of t only. Differentiating y twice with respect to x keeping t constant, and with respect to t keeping x constant,

$$\frac{\partial^2 y}{\partial x^2} = g \frac{\partial^2 f}{\partial x^2}$$

$$\text{and} \quad \frac{\partial^2 y}{\partial t^2} = f \frac{\partial^2 g}{\partial t^2}$$

Substituting in Eq. (19.12)

$$g \frac{\partial^2 f}{\partial x^2} = \frac{1}{V_p^2} f \frac{\partial^2 g}{\partial t^2}$$

$$\frac{1}{f} \frac{\partial^2 f}{\partial x^2} = \frac{1}{g V_p^2} \frac{\partial^2 g}{\partial t^2} = -\alpha^2 \text{ (say)} \quad (19.13)$$

where α^2 is the separation constant. Since each side of the equation is a function of a single variable,

$$\frac{1}{g V_p^2} \frac{\partial^2 g}{\partial t^2} = -\alpha^2$$

$$\text{or} \quad \frac{\partial^2 g}{\partial t^2} + \alpha^2 V_p^2 g = 0 \quad (19.14)$$

The characteristic equation is:

$$m^2 + \alpha^2 V_p^2 = 0$$

$$\text{or} \quad m_1 = \pm i \alpha V_p,$$

so that the general solution is:

$$g = C_1 \cos(\alpha V_p t) + C_2 \sin(\alpha V_p t) \quad (19.15)$$

$$\text{Let} \quad \alpha V_p = \omega = 2\pi$$

where ω is the angular velocity and ν the frequency. Since $V_p = \nu \lambda$,

$$\alpha = \frac{2\pi \nu}{\nu \lambda} = \frac{2\pi}{\lambda}$$

and $\phi = \phi_x + \phi_y + \phi_z$

so that the wave equation becomes:

$$\nabla^2 \psi + \frac{8\pi^2 m}{h^2} (\epsilon - \phi) \psi = 0 \quad (19.20)$$

This is the *time-independent Schrödinger wave equation*. In general, as for the vibrating string, the wave function ψ is dependant upon position as well as time, and may even be a complex function having real and imaginary parts. Consequently, there is a corresponding general *time-dependant Schrödinger wave-equation*, but for stationary states of the system (standing waves), the case of interest to us here, we need consider only this form of equation (Eq. (19.20)).

19.8 Probability Function: ψ

The quantum mechanics developed by Edwin Schrödinger differs from Newton's classical mechanics in its aim as well as its method. Instead of attempting to find equations which give the exact positions and velocities of particles, Schrödinger devised a method of calculating a function of time and position from which the most probable positions and velocities of particles could be derived.

Schrödinger postulated a particular second-order differential equation for wave functions ψ of the coordinates of a system and time. The square of the absolute value of a given wave function, $|\psi|^2$, is interpreted as a probability distribution function. Solutions of the Schrödinger equation give a series of allowed energy levels for many of the systems considered.

A fundamental postulate of quantum mechanics is that the quantity $\psi\psi^* dx dy dz$ is the probability that the particle represented by the wave function $\psi(x, y, z, t)$ is in the elemental volume $dx dy dz$ at the time t , and ψ^* is the complex conjugate of ψ . Thus, $\psi\psi^*$ is the probability density for the particle.

Since the particle must be somewhere in space, it is necessary that the probability density satisfy the *normalization condition*:

$$\int_{-\infty}^{\infty} \int_{-\infty}^{\infty} \int_{-\infty}^{\infty} \psi\psi^* dx dy dz = 1 \quad (19.21)$$

19.9 Particle in a Box

Let us assume a monatomic ideal gas confined in a box of dimensions a , b and c , such that:

$$0 < x < a, 0 < y < b \text{ and } 0 < z < c.$$

Molecules have only translational kinetic energy. For simplification, let us consider that the particles move only in the x -direction. The Schrodinger equation applied to a single particle gives

$$\frac{d^2 \psi_x}{dx^2} + \frac{8\pi^2 m}{h^2} [\epsilon_x - \phi_x] \psi_x = 0 \quad (19.22)$$

and

$$\psi_{nz} = \left[\frac{2}{c} \right]^{1/2} \sin \left[n_z \pi \frac{z}{c} \right]$$

Therefore,

$$\psi_{n_x, n_y, n_z} = \left[\frac{8}{abc} \right]^{1/2} \sin \left[n_x \pi \frac{x}{a} \right] \sin \left[n_y \pi \frac{y}{b} \right] \sin \left[n_z \pi \frac{z}{c} \right] \quad (19.32)$$

From Eqs (19.27, 19.28 and 19.29),

$$\begin{aligned} \epsilon &= \epsilon_x + \epsilon_y + \epsilon_z \\ &= \frac{h^2}{8m} \left[\frac{n_x^2}{a^2} + \frac{n_y^2}{b^2} + \frac{n_z^2}{c^2} \right] \end{aligned} \quad (19.33)$$

If $a = b = c = L$, then

$$\epsilon = \frac{h^2}{8mL^2} [n_x^2 + n_y^2 + n_z^2]$$

which is the same equation developed earlier, Eq. (19.6), from Bohr-Sommerfeld action integral.

If V is the volume of the cubical box,

$$\epsilon = \frac{h^2}{8mV^{2/3}} [n_x^2 + n_y^2 + n_z^2] \quad (19.34)$$

which shows the energy values depending upon the volume of the system.

The specification of an integer for each n_x , n_y and n_z is the specification of a quantum state (or energy state) of a particle. All states characterized by values of the n 's such that $n_x^2 + n_y^2 + n_z^2 = \text{constant}$, will have the same energy.

If $n_x^2 + n_y^2 + n_z^2 = 66$,

	1	2	3	4	5	6	7	8	9	10	11	12
n_x	8	1	1	7	1	4	7	4	1	5	5	4
n_y	1	8	1	4	7	1	1	7	4	5	4	5
n_z	1	1	8	1	4	7	4	1	7	4	5	5

All the 12 states for which $n_x^2 + n_y^2 + n_z^2 = 66$, have the same energy

$\epsilon = 66 \frac{h^2}{8mV^{2/3}}$. There are 12 quantum states with the same energy level, and it is

said that this energy level has a degeneracy (or statistical weight) of 12. In any actual case, $n_x^2 + n_y^2 + n_z^2$ is an enormous number so that the degeneracy of an actual energy level is extremely large.

When a particle has a number of quantum states at a certain energy level, it is said to be *degenerate*. The degeneracy is designated by g . If $n_x = n_y = n_z = 1$, the particle is at its lowest energy level, $\epsilon = (3h^2)/[8mV^{2/3}]$, which is *non-degenerate*

($g = 1$). If $n_x^2 + n_y^2 + n_z^2 = 11$, the degeneracy is 3, if it is 12, g is again unity with $n_x = n_y = n_z = 2$. If it is 14, $g = 6$, and so on.

19.10 Rigid Rotator

A diatomic molecule may be approximated to a “dumbbell” with its two atoms connected by a massless spring (Fig. 19.4). The molecule is free to rotate about its centre of gravity (c.g.) and may also oscillate along the line of centres.

Let r be the interatomic distance, and m_1 and m_2 be the masses of atoms at the respective distances r_1 and r_2 from the c.g. Since,

$$r = r_1 + r_2 \quad \text{and} \quad m_1 r_1 = m_2 r_2,$$

it yields

$$r_1 = \frac{m_2 r}{m_1 + m_2} \quad \text{and} \quad r_2 = \frac{m_1 r}{m_1 + m_2}$$

Moment of inertia of the molecule is:

$$I = m_1 r_1^2 + m_2 r_2^2 = \frac{m_1 m_2}{m_1 + m_2} r^2 = m' r^2$$

where $m' = \frac{m_1 m_2}{m_1 + m_2}$ is the reduced mass of the molecule.

Solving Schrödinger equation in spherical polar coordinates, the discrete energy values of rotational KE are determined as given below:

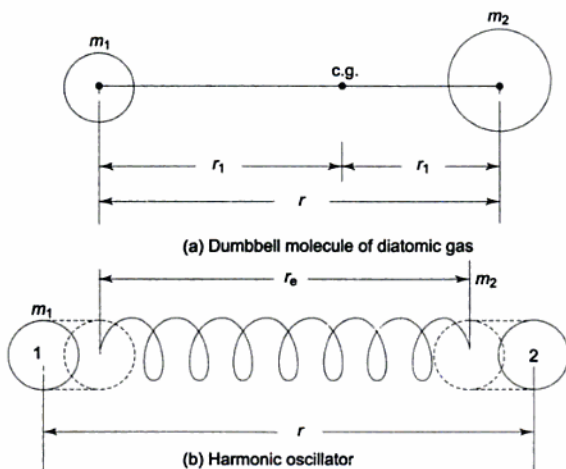

Fig. 19.4

$$\epsilon_{\text{rot}} = \frac{h^2}{8\pi^2 I} j(j+1) \quad (19.35)$$

where

$$j = 0, 1, 2, \dots$$

19.11 Harmonic Oscillator

Let us now consider the solution of the Schrödinger equation for a one-dimensional harmonic oscillator. The results can be applied to the vibrational motion of a diatomic molecule and also to the behaviour of crystalline solids.

For a particle of mass m , the potential energy for one-dimensional harmonic motion:

$$\phi_x = \frac{1}{2} m v_x^2 = \frac{1}{2} m (2\pi\nu_0 x)^2 = 2m\pi^2 \nu_0^2 x^2 \quad (19.36)$$

where x is the displacement of the particle from its equilibrium position at $x = 0$ and ν_0 is the frequency of oscillation.

One dimensional Schrödinger equation is thus:

$$\frac{d^2\psi_x}{dx^2} + \frac{8\pi^2 m}{h^2} [\epsilon_x - 2m\pi^2 \nu_0^2 x^2] \psi_x \quad (19.37)$$

Solutions of Eq. (19.37) are desired for which $\psi_x \rightarrow 0$ as $x \rightarrow \pm \infty$, which yield

$$\epsilon_x = \epsilon_{\text{vib}} = h\nu_0 \left(n + \frac{1}{2} \right) \quad (19.38)$$

where $n = 0, 1, 2, \dots$. Discrete energy levels are thus obtained. A finite energy $\frac{1}{2} h\nu_0$ is associated with the lowest (or ground state) energy level.

19.12 Phase Space

A monatomic gas having only translatory motion of its molecules is the simplest system to consider from the statistical viewpoint. When the position and motion of each atom of the gas are prescribed, the state of the gas is completely specified. If the six quantities x, y, z, p_x, p_y, p_z are given for each atom, the state of the gas is determined. Let us imagine a six-dimensional hyperspace or *phase space* having three-position and three-momentum coordinates. Every particle has its representative point in phase space, and is known as the *phase point*.

Let us subdivide the phase space into small elements of volume, called *cells*, and the volume of one cell, H , is:

$$H = dx dy dz dp_x dp_y dp_z$$

This volume is small compared to the dimensions of the system, but large enough to contain many atoms. Every atom of the gas must be in a cell. The cells are numbered $1, 2, 3, \dots, i, \dots$ and the number of particles in the cells are $N_1, N_2,$

N_3, \dots, N_i, \dots with $N_i > 1$. The basic problem of statistical mechanics is to determine *how the particles distribute themselves in the cells of phase space*.

Heisenberg's uncertainty principle places a quantitative limit on the product of the uncertainties in the position and momentum of the particle,

$$\Delta x \Delta p_x = h, \Delta y \Delta p_y = h, \Delta z \Delta p_z = h$$

where h is the Planck's constant, 6.624×10^{-34} J-s. The total uncertainty in locating a particle in phase space is:

$$\Delta x \Delta y \Delta z \Delta p_x \Delta p_y \Delta p_z = h^3$$

The particle lies somewhere within an element of phase space of volume h^3 , which is known as a *compartment*. The number of compartments per cell is:

$$g = H/h^3 \quad (19.39)$$

where $g \gg 1$ and h^3 has the dimension of volume in phase space, since

$$(\text{Js})^3 = (\text{Nm s})^3 = \text{m}^3 (\text{Ns})^3$$

$$h^3 = (\text{length})^3 \times (\text{momentum})^3$$

A quantum state corresponds to a volume h^3 in phase space, and an energy level corresponds to a cell of volume H , so that g is nothing but the degeneracy of the energy level.

19.13 Microstate and Macrostate

The basic problem in statistical thermodynamics is to determine the most probable distribution of the particles among degenerate energy levels under the constraints of constant total number of particles and constant system energy. In other words, the object is to determine the most probable way in which the particles distribute themselves in the cells of phase space.

If all the six coordinates x, y, z, p_x, p_y and p_z of each particle in a system are specified in phase space, it defines the *microstate* of the system. Such a specification exactly locates the compartment in which each particle of the system lies. This detailed description is not necessary to determine the observable thermodynamic properties of a system. For example, the pressure exerted by a gas depends upon how many molecules have the specified momenta, i.e. how many molecules lie within each element of momentum space $dp_x \cdot dp_y \cdot dp_z$. Similarly, the density of a gas depends on how many molecules are there in each volume element $dx \, dy \, dz$ of ordinary space. Thus, the observable properties depend only on how many particles lie in each cell of phase space and do not require any information on which particle lies in which cell. A *macrostate* of a system is defined if the number of particles in each cell of phase space are specified. In Fig. 19.5, three cells i, j and k are shown to have four compartments each. The particular microstate is specified by stating that there is one particle (denoted by a) in compartment 1 of cell i ; two particles in cell j , one each in the compartments 2 and 4; three particles in cell k , one in compartment 2 and two in compartment 3, and so on. The corresponding macrostate is specified by simply mentioning that $N_i = 1, N_j = 2$ and $N_k = 3$.

Therefore,

$$\ln x! = \int_1^x \ln x \, dx$$

We know,

$$\int u \, dv = uv - \int v \, du$$

Putting $u = \ln x$ and $v = x$,

$$\int \ln x \, dx = \ln x \cdot x - \int x \frac{1}{x} \, dx = x \ln x - x$$

$$\ln x! = \int_1^x \ln x \, dx = [x \ln x - x]_1^x = x \ln x - x + 1$$

Since x is large, 1 can be neglected. So,

$$\ln x! = x \ln x - x \quad (19.43)$$

This is known as *Stirling's approximation*.

19.16 Maxwell-Boltzmann Distribution Function

Taking logarithm of both sides of Eq. (19.42), and using Stirling's approximation,

$$\ln W = \Sigma [N_i \ln g_i - N_i \ln N_i + N_i]$$

As the particles in the cells of phase space shift around, they change from one energy level to another, and N_i 's will change. If the system is in thermodynamic equilibrium with maximum W , a small change in W represented by $\delta \ln W$ will be zero. Since the value of g_i is assumed to be constant,

$$\delta \ln W = \Sigma \left[\ln g_i \, \delta N_i - N_i \frac{1}{N_i} \delta N_i - \ln N_i \, \delta N_i + \delta N_i \right] = 0$$

$$\text{or } \Sigma \ln \frac{g_i}{N_i} \delta N_i = 0 \quad (19.44)$$

where N_i is the number of particles in the i -th cell (or i -th energy level) in thermodynamic equilibrium. However, δN_i 's are not independent, but are subject to the equations of constraint,

$$(1) \quad \begin{aligned} N &= \Sigma N_i = \text{constant} \\ \Sigma \delta N_i &= 0 \end{aligned} \quad (19.45)$$

$$(2) \quad \begin{aligned} U &= \Sigma \epsilon_i N_i = \text{constant} \\ \Sigma \epsilon_i \delta N_i &= 0 \end{aligned} \quad (19.46)$$

Laogrange's method of undetermined multipliers will now be used. Multiplying Eq. (19.45) by $-\ln B$ and Eq. (19.46) by $-\beta$ and adding to Eq. (19.44),

$$\Sigma \left[\ln \frac{g_i}{N_i} - \ln B - \beta \epsilon_i \right] \delta N_i = 0$$

$$= KN \ln \frac{Z}{N} + K\beta U + KN \quad (19.65)$$

where $\sum N_i = N$ and $\sum \epsilon_i N_i = U$.

$$\left(\frac{\partial S}{\partial U} \right)_V = KN \cdot \frac{1}{Z} \frac{dz}{d\beta} \left(\frac{\partial \beta}{\partial U} \right)_V + K\beta + KU \left(\frac{\partial \beta}{\partial U} \right)_V$$

Since $Z = \sum g_i \epsilon^{-\beta \epsilon_i}$

$$\frac{dZ}{d\beta} = -\sum \epsilon_i g_i \epsilon^{-\beta \epsilon_i} = -\frac{\sum \epsilon_i N_i \sum g_i \epsilon^{-\beta \epsilon_i}}{N_i} = -\frac{UZ}{N}$$

$$\left(\frac{\partial S}{\partial U} \right)_V = KN \frac{1}{Z} \left(-\frac{UZ}{N} \right) \left(\frac{\partial \beta}{\partial U} \right)_V + K\beta + KU \left(\frac{\partial \beta}{\partial U} \right)_V = K\beta$$

From $T dS = dU + p dV$

$$\left(\frac{\partial S}{\partial U} \right)_V = 1/T$$

$$K\beta = 1/T$$

or $\beta = 1/(KT)$ (19.66)

The constant β is thus determined. Therefore, from Eq. (19.61)

$$N_i = \frac{Ng_i}{Z} e^{-\epsilon_i/KT} \quad (19.67)$$

where $Z = \sum g_i e^{-\epsilon_i/KT}$ (19.68)

The internal energy U of the system:

$$U = \sum \epsilon_i N_i = \frac{N}{Z} \sum g_i \epsilon_i e^{-\epsilon_i/KT}$$

From Eq. (19.68),

$$\frac{dZ}{dT} = \frac{1}{KT^2} \sum g_i \epsilon_i e^{-\epsilon_i/KT}$$

$$U = \frac{N}{Z} KT^2 \frac{dz}{dT}$$

or $U = NKT^2 \frac{d}{dT} (\ln Z)$ (19.69)

From Eq. (19.65),

$$\begin{aligned} S &= KN \ln \frac{Z}{N} + K \frac{1}{KT} U + KN \\ &= KN \left[\ln \frac{Z}{N} + 1 \right] + \frac{U}{T} \end{aligned} \quad (19.70)$$

The Helmholtz function, $F = U - TS$, is given by

$$F = -NKT \left[\ln \frac{Z}{N} + 1 \right] \quad (19.71)$$

Therefore, from Eq. (19.72),

$$Z = \frac{m^3}{h^3} V \left[\frac{2\pi KT}{m} \right]^{3/2}$$

$$\text{or } Z = \frac{V}{h^3} [2\pi mKT]^{3/2} \quad (19.73)$$

Substituting in the equation,

$$\begin{aligned} N_i &= \frac{Ng_i}{z} e^{-(\epsilon_i)/KT} \\ &= \frac{Ng_i h^3}{V (2\pi mKT)^{3/2}} e^{-(mv_i^2)/(2KT)} \end{aligned} \quad (19.74)$$

Substituting N_i by d^6N ,

$$\begin{aligned} d^6N &= \frac{N}{V} \frac{m^3}{h^3} \frac{dx dy dz dv_x dv_y dv_z}{(2\pi mKT)^{3/2}} \\ &\quad e^{-(m(v_x^2 + v_y^2 + v_z^2))/(2KT)} \\ &= \frac{N}{V} \left[\frac{m}{2\pi KT} \right]^{3/2} e^{-(m(v_x^2 + v_y^2 + v_z^2))/(2KT)} \\ &\quad dx dy dz dv_x dv_y dv_z \end{aligned} \quad (19.75)$$

Integration of this equation over all values of v_x , v_y and v_z gives

$$d^3N = \frac{N}{V} \left[\frac{m}{2\pi KT} \right]^{3/2} \left[\frac{2\pi KT}{m} \right]^{3/2} dx dy dz$$

$$\text{or, } \frac{d^3N}{dx dy dz} = \frac{N}{V}$$

The number of atoms per unit volume of ordinary space is thus a constant, confirming that the atoms are uniformly distributed in the gas volume.

The Eq. (19.75), when integrated over all the values of x , y and z , gives the distribution of atoms in velocity space, as given below:

$$d^3N = N \left[\frac{m}{2\pi KT} \right]^{3/2} e^{-[mv^2]/[2KT]} dv_x dv_y dv_z$$

This equation is precisely the same as the Maxwell-Boltzmann velocity distribution as derived from the kinetic theory of gases and given by Eq. (21.49), provided K is recognised as the Boltzmann constant.

Now,

$$\begin{aligned} Z &= \frac{V}{h^3} [2\pi mKT]^{3/2} \\ \ln Z &= \ln V + \frac{3}{2} \ln T + \frac{3}{2} \ln 2\pi m K - 3 \ln h \end{aligned}$$

The internal energy of the gas from Eq. (19.69),

$$\begin{aligned} U &= NKT^2 \frac{d}{dT} \ln Z \\ &= NKT^2 \frac{3}{2} \frac{1}{T} = \frac{3}{2} NKT = \frac{3}{2} n\bar{R}T \\ u &= \frac{3}{2} \bar{R}T \text{ and } c_v = \frac{3}{2} \bar{R} \end{aligned}$$

The results agree with the kinetic theory and the equipartition principle. From Eq. (19.71),

$$\begin{aligned} F &= -NKT \left[\ln \frac{Z}{N} + 1 \right] \\ &= -NKT \left[\ln V + \frac{3}{2} \ln (2\pi mKT) - 3 \ln h + \ln N + 1 \right] \end{aligned}$$

Now,

$$p = - \left[\frac{\partial F}{\partial V} \right]_T = \frac{NKT}{V}$$

or

$$pV = NKT = n\bar{R}T$$

which is the equation of state of an ideal gas.

From Eq. (19.70),

$$\begin{aligned} S &= NK \left[\ln \frac{Z}{N} + 1 \right] + \frac{U}{T} \\ &= NK \left[\ln V + \frac{3}{2} \ln T + \frac{3}{2} \ln 2\pi mk \right. \\ &\quad \left. - 3 \ln h - \ln N + 1 \right] + \frac{3}{2} \frac{NKT}{T} \end{aligned}$$

Now,

$$V = \frac{NKT}{p}$$

$$\ln V = \ln N + \ln K + \ln T - \ln p$$

Substituting,

$$\begin{aligned} S &= n\bar{R} \left[\ln N + \ln K + \ln T - \ln p + \frac{3}{2} \ln T \right. \\ &\quad \left. + \frac{3}{2} \ln 2\pi mK - 3 \ln h - \ln N + 1 + \frac{3}{2} \right] \end{aligned}$$

The molar entropy

$$\begin{aligned} \bar{s} &= \bar{R} \left[\frac{5}{2} \ln T - \ln p + \frac{5}{2} \ln K + \frac{3}{2} \ln 2\pi m \right. \\ &\quad \left. - 3 \ln h + \frac{5}{2} \right] \end{aligned} \tag{19.76}$$

where C is a constant

$$N = \int dN_z = C \int e^{-\epsilon_z/KT} dz$$

Let $\bar{\epsilon}_z$ = mean energy of a single particle associated with coordinate z

$$= \frac{\sum \epsilon_z dN_z}{\sum dN_z} = \frac{\int \epsilon_z e^{-\epsilon_z/KT} dz}{\int e^{-\epsilon_z/KT} dz}$$

If ϵ_z is a quadratic function of z , i.e. $\epsilon_z = az^2$, where a is a constant,

$$\bar{\epsilon}_z = \frac{\int_0^{\infty} az^2 \cdot e^{-az^2/KT} dz}{\int_0^{\infty} e^{-az^2/KT} dz}$$

Let $az^2/KT = y$

$$\frac{a}{KT} 2z dz = dy$$

$$dz = \frac{1}{2} \left[\frac{KT}{ay} \right]^{1/2} dy$$

$$\begin{aligned} \text{Numerator} &= \int_0^{\infty} y KT e^{-y} \cdot \frac{1}{2} \left[\frac{KT}{ay} \right]^{1/2} dy \\ &= \frac{1}{2} \frac{(KT)^{3/2}}{\sqrt{a}} \int_0^{\infty} y^{\frac{3}{2}-1} e^{-y} dy = \frac{1}{2} \frac{(KT)^{3/2}}{\sqrt{a}} \frac{\sqrt{\pi}}{2} \end{aligned}$$

$$\begin{aligned} \text{Denominator} &= \int_0^{\infty} e^{-y} \frac{1}{2} \left[\frac{KT}{ay} \right]^{1/2} dy \\ &= \frac{1}{2} \left[\frac{KT}{a} \right]^{1/2} \int_0^{\infty} y^{\frac{1}{2}-1} e^{-y} dy \\ &= \frac{1}{2} \frac{(KT)^{1/2}}{\sqrt{a}} \sqrt{\pi} \\ \epsilon_z &= \frac{\frac{1}{2} \frac{(KT)^{3/2}}{\sqrt{a}} \frac{\sqrt{\pi}}{2}}{\frac{1}{2} \frac{(KT)^{1/2}}{\sqrt{a}} \sqrt{\pi}} = \frac{1}{2} KT \end{aligned} \quad (19.79)$$

If the energy associated with a particular coordinate is a quadratic function of that coordinate, the average energy of a particle is $\frac{1}{2}KT$. This is the *principle of equipartition of energy*.

19.24 Statistics of a Photon Gas

Thermal radiation can be considered to be a photon gas consisting of photons which have no rest mass, but possess momenta. The number of photons though treated as particles are not conserved. The total energy of the photons is, however, constant. There is no restriction on the number of photons occupying the same quantum number or a compartment in a cell of phase space. Thus, the photons follow the Bose-Einstein statistics, the thermodynamic probability of which is given by:

$$W = \prod_i \frac{(g_i + N_i - 1)!}{(g_i - 1)! N_i!}$$

The condition of the maximum thermodynamic probability gives

$$\sum \ln \frac{g_i + N_i}{N_i} \delta N_i = 0$$

subject to the constraint of total energy of photons (and not the number), i.e.

$$\sum \varepsilon_i \delta N_i = 0$$

Multiplying the above equation by $-\beta$ and adding to the earlier equation:

$$\sum \left[\ln \frac{g_i + N_i}{N_i} - \beta \varepsilon_i \right] \delta N_i = 0$$

Since δN_i 's are independent,

$$\ln \frac{g_i + N_i}{N_i} = \beta \varepsilon_i$$

or,

$$N_i/g_i = \frac{1}{e^{\beta \varepsilon_i} - 1} \quad (19.80)$$

where $\beta = 1/KT$. The energy of a photon of frequency ν is

$$\varepsilon = h\nu$$

and its momentum is

$$p = h/\lambda = h\nu/c = \varepsilon/c$$

where c is the velocity of light. Since light can be both right-handed and left-handed polarized photons, the degeneracy g_i of the energy level ε_i is

$$g_i = \frac{2 \, dx \, dy \, dz \, dp_x \, dp_y \, dp_z}{h^3}$$

Substituting d^6N for the N_i in Eq. (19.80), putting $\varepsilon = pc$ and $\beta = 1/KT$,

$$d^6N = \frac{2 \, dx \, dy \, dz \, dp_x \, dp_y \, dp_z}{h^3} \frac{1}{e^{pc/KT} - 1}$$

Integrating the equation over x , y and z , we get the distribution of photons in momentum space,

Substituting d^6N for N_i , ϵ for ϵ_i , and the expression for g_i ,

$$d^6N = \frac{2}{h^3} \frac{1}{Be^{-\epsilon/KT} + 1} dx dy dz dp_x dp_y dp_z$$

Integrating over x, y and z

$$d^3N = \frac{2V}{h^3} \frac{1}{Be^{-\epsilon/KT} + 1} dp_x dp_y dp_z \quad (19.89)$$

To evaluate B , let us make the substitution

$$B = e^{-\epsilon_m/KT},$$

where ϵ_m is the reference energy which is a function of temperature. Then,

$$d^3N = \frac{2V}{h^3} \frac{1}{e^{(\epsilon - \epsilon_m)/KT} + 1} dp_x dp_y dp_z \quad (19.90)$$

This is the distribution of electrons in momentum space. The number density of electrons in this space:

$$\rho = \frac{2V}{h^3} \frac{1}{e^{(\epsilon - \epsilon_m)/KT} + 1} \quad (19.91)$$

When $T = 0$ K, let $\epsilon_m = \epsilon_{m0}$. For a cell in momentum space for which $\epsilon < \epsilon_{m0}$,

$$\rho_0 = \frac{2V}{h^3} \quad (\text{at } T = 0 \text{ K, } \epsilon < \epsilon_{m0}) \quad (19.92)$$

At absolute zero, the density of representative points in momentum space is constant and equal to $2V/h^3$ in all cells for which $\epsilon < \epsilon_{m0}$.

If $\epsilon > \epsilon_{m0}$ at $T = 0$ K,

$$\rho_0 = 0 \quad (\text{at } T = 0 \text{ K, } \epsilon > \epsilon_{m0})$$

There can be no electron whose energy is greater than ϵ_{m0} at $T = 0$ K. Thus, ϵ_{m0} is the *maximum energy of the electron at absolute zero*, which is referred to as *Fermi energy* (Fig. 19.8).

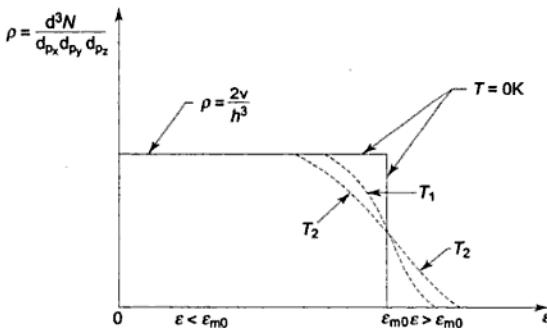

Fig. 19.8 Distribution in momentum space of Fermi-Dirac statistics at $T = 0$ K (full line) and two higher temperatures T_1 and T_2

Therefore, z is also multiplicative.

$$z = z_{\text{trans}} \cdot z_{\text{rot}} \cdot z_{\text{vib}} \cdot z_{\text{elect}} \cdot z_{\text{nucl}} \cdot z_{\text{chem}}$$

To determine the z of a molecule, it is necessary to find each of the contributing partition functions.

$$z_{\text{trans}} = \frac{V}{h^3} (2 \pi m K T)^{3/2} \quad (\text{Eq. 19.73})$$

(evaluated earlier)

The energy levels of a simple harmonic oscillator are:

$$\epsilon_{\text{vib}} = \left(n + \frac{1}{2} \right) h \nu \quad (\text{Eq. 19.38})$$

With $g_1 = 1$,

$$\begin{aligned} Z_{\text{vib}} &= \sum_{n=0}^{\infty} e^{-\{(n + \frac{1}{2})h\nu\}/KT} \\ &= \sum_{n=0}^{\infty} e^{-nh\nu/KT} \cdot e^{-h\nu/2KT} \\ &= e^{-h\nu/2KT} [1 + e^{-h\nu/KT} + e^{-2h\nu/KT} + e^{-3h\nu/KT} + \dots] \\ &= \frac{e^{-h\nu/2KT}}{1 - e^{-h\nu/KT}} \end{aligned} \quad (19.102)$$

Similarly, Z_{rot} , Z_{chem} , ... etc. are to be evaluated.

So far z refers to a single particle. The total partition function of N identical distinguishable particles:

$$Z_{\text{tot}} = Z^N = [\sum e^{-\beta \epsilon_i}]^N$$

For N indistinguishable particles,

$$Z_{\text{tot}} = \frac{z^N}{N!} = \frac{[\sum e^{-\beta \epsilon_i}]^N}{N!} \quad (19.103)$$

19.26.1 Internal Energy

Average energy of a particle is:

$$\bar{\epsilon} = \frac{\sum N_i \epsilon_i}{\sum N_i} = \frac{\sum \epsilon_i e^{-\beta \epsilon_i}}{\sum e^{-\beta \epsilon_i}} = \frac{\sum \epsilon_i e^{-\beta \epsilon_i}}{z}$$

Now,

$$\left[\frac{\partial z}{\partial \beta} \right]_V = \frac{\partial}{\partial \beta} [\sum e^{-\beta \epsilon_i}] = -\sum \epsilon_i e^{-\beta \epsilon_i}$$

$$\therefore \bar{\epsilon} = -\frac{1}{z} \left[\frac{\partial z}{\partial \beta} \right]_V = -\left[\frac{\partial \ln z}{\partial \beta} \right]_V$$

The internal energy of the system is:

$$U = \sum N_i \varepsilon_i = N\bar{\varepsilon}$$

$$U = -N \left[\frac{\partial \ln z}{\partial \beta} \right]_V$$

In terms of Z_{tot} ,

$$U = - \left[\frac{\partial \ln z_{\text{tot}}}{\partial \beta} \right]_V$$

Now,

$$\beta = \frac{1}{KT},$$

$$\begin{aligned} U &= -NK \left[\frac{\partial \ln z}{\partial \frac{1}{T}} \right]_V = NKT^2 \left[\frac{\partial \ln z}{\partial T} \right]_V \\ &= n\bar{R}T^2 \left[\frac{\partial \ln z}{\partial T} \right]_V \end{aligned} \quad (19.104)$$

$$c_v = \frac{1}{n} \left(\frac{\partial U}{\partial T} \right) = \frac{\bar{R}}{T^2} \left[\frac{\partial^2 \ln z}{\partial \left(\frac{1}{T} \right)^2} \right]_V \quad (19.105)$$

19.26.2 Entropy

In terms of the single-partition function,

$$\begin{aligned} S &= NK \left[\ln \frac{z}{N} + 1 \right] + \frac{U}{T} \quad [\text{Eq. 19.70}] \\ &= n\bar{R} \left[\ln \frac{z}{N} + T \left(\frac{\partial \ln z}{\partial T} \right)_V + 1 \right] \end{aligned} \quad (19.106)$$

In terms of Z_{tot} , since

$$Z_{\text{tot}} = Z^N/N!$$

$$\begin{aligned} \ln Z_{\text{tot}} &= N \ln Z - N \ln N + N = N \left[\ln \frac{z}{N} + 1 \right] \\ S &= K \left[\ln z_{\text{tot}} + T \left(\frac{\partial \ln z_{\text{tot}}}{\partial T} \right)_V \right] \end{aligned} \quad (19.107)$$

19.26.3 Helmholtz Function

$$F = U - TS$$

$$= n\bar{R}T^2 \left(\frac{\partial \ln z}{\partial T} \right)_V - n\bar{R}T \left[\ln \left(\frac{z}{N} \right) + T \left(\frac{\partial \ln z}{\partial T} \right)_V + 1 \right]$$

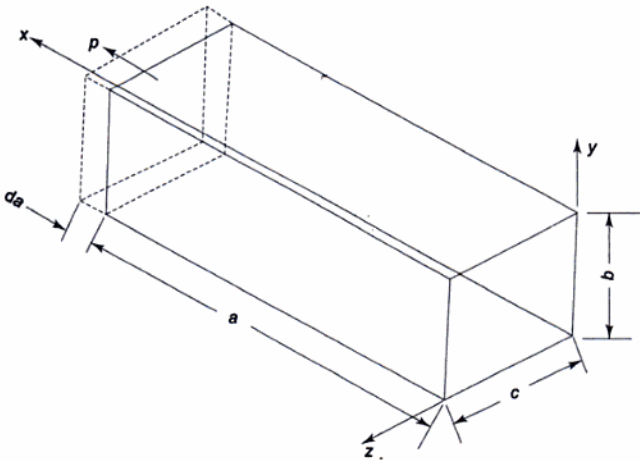

Fig. 19.11 Work transfer

$$\begin{aligned}\bar{F} &= \frac{KT}{z} \left[\frac{\partial z}{\partial a} \right]_T = KT \left[\frac{\partial \ln z}{\partial a} \right]_T \\ \delta W &= N\bar{F} da = NKT \left[\frac{\partial \ln z}{\partial a} \right]_T da \\ \delta W &= n\bar{R}T \left[\frac{\partial \ln z}{\partial V} \right]_T dV = p dV\end{aligned}\quad (19.111)$$

which is valid for a reversible process.

Now,

$$\begin{aligned}\delta Q &= dU + \delta W \\ &= n\bar{R} d \left[T^2 \left\{ \frac{\partial \ln z}{\partial T} \right\}_V \right] + n\bar{R}T \left[\frac{\partial \ln z}{\partial V} \right]_T dV\end{aligned}$$

Since

$$d \ln Z = \left[\frac{\partial \ln z}{\partial T} \right]_V dT + \left[\frac{\partial \ln z}{\partial V} \right]_T dV$$

$$\begin{aligned}\delta Q &= n\bar{R} d \left[T^2 \left\{ \frac{\partial \ln z}{\partial T} \right\}_V \right] - n\bar{R}T \left[\frac{\partial \ln z}{\partial T} \right]_V dT + n\bar{R}T d \ln Z \\ &= n\bar{R}T d \left[\ln z + T \left\{ \frac{\ln z}{T} \right\}_V \right]\end{aligned}$$

Using Eq. (19.105),

$$\delta Q = T dS \quad (19.112)$$

which is valid for a reversible process.

19.26.8 Properties of Ideal Gases

As shown in Fig. 19.11,

$$p = \frac{N\bar{F}}{bc} = \frac{NKT}{bc} \left[\frac{\partial \ln z}{\partial a} \right]_T$$

Now,

$$Z = \frac{V}{h^3} (2\pi mKT)^{3/2} = \frac{abc}{h^3} (2\pi mKT)^{3/2}$$

$$\left[\frac{\partial \ln z}{\partial a} \right]_T = \frac{1}{a}$$

$$p = \frac{NKT}{bc} \cdot \frac{1}{a} = \frac{NKT}{V}$$

or

$$pV = NKT \quad (19.113)$$

which is the equation of state of an ideal gas.

For an ideal gas,

$$\begin{aligned} G &= U - TS + pV = U - TS + n\bar{R}T \\ &= U - T \left[\frac{U}{T} + n\bar{R} + n\bar{R} \ln \frac{z}{N} \right] + n\bar{R}T \\ &= -n\bar{R}T \ln \frac{z}{N} \end{aligned} \quad (19.114)$$

$$S = n\bar{R} \left[\ln \frac{z}{N} + T \left(\frac{\partial \ln z}{\partial T} \right)_p \right]$$

$$H = G + TS = n\bar{R}T^2 \left[\frac{\partial \ln z}{\partial T} \right]_p \quad (19.115)$$

$$c_p = \frac{\partial}{\partial T} \left[\bar{R}T^2 \left(\frac{\partial \ln z}{\partial T} \right)_p \right] \quad (19.116)$$

19.27 Specific Heat of Solids

The classical theory of specific heat of a solid assumes that the molecules of a solid, when displaced from their equilibrium positions, are acted on by a linear restoring force, and oscillate about these positions with simple harmonic motion. With increasing temperature, the amplitude and, hence the energy, of oscillatory motion increases. The specific heat at constant volume is a measure of the energy that must be supplied to increase the energy of these molecular vibrations. Since

both K.E. and P.E. of a harmonic oscillator are quadratic functions of their respective coordinates, the equipartition principle applies, and the mean total energy is $KT \left[\frac{1}{2}KT \text{ for KE and } \frac{1}{2}KT \text{ for PE} \right]$. The molecules are free to oscillate in three dimensions, and so a mean energy $3KT$ is assigned to each molecule. Therefore, the total energy U of a system of N molecules in thermal equilibrium at a temperature T is

$$U = 3NKT = 3n\bar{R}T$$

$$c_v = 3\bar{R}$$

Figure 19.12 shows experimental values of c_p and c_v for copper. At high temperatures, $c_v \approx 3\bar{R}$, but it decreases to zero at 0 K.

The first explanation of the decrease in c_v at low temperature was given by Einstein, who suggested that quantum theory should be applied. Each atom behaves like a simple harmonic oscillator with normal frequency ν . The energy levels of a simple harmonic oscillator are:

$$\epsilon = \left(n + \frac{1}{2} \right) h\nu, n = 0, 1, 2, 3$$

The partition function is:

$$\begin{aligned} Z &= \sum \exp \left[- \left(n + \frac{1}{2} \right) h\nu / KT \right] \\ &= \frac{\exp(-h\nu/2KT)}{1 - \exp(-h\nu/KT)} \end{aligned}$$

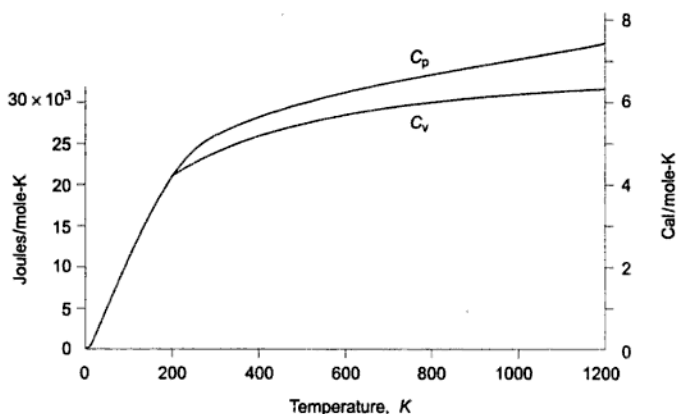

Fig. 19.12 c_p and c_v for copper as functions of temperature at a constant pressure of 1 atm

(b) Neglecting relativistic effects, the wavelength is:

$$\lambda = \frac{h}{mv} = \frac{6.625 \times 10^{-34}}{9.106 \times 10^{-31} \times 10^6} = 7.3 \times 10^{-10} \text{ m}$$

(c) Since the wavelength is very small in (a), the motion is rectilinear and quantum considerations are not important in this motion. In case (b), although 7.3×10^{-10} m is a small distance indeed, it is quite large for the motion of microscopic particles like electrons. Therefore, the quantum effects can influence significantly on electron motion.

Example 19.2 Consider a cubical box of edge 10 cm, containing gaseous helium at 300 K. Evaluate the energy ϵ_x and its corresponding n_x .

Solution

$$\begin{aligned}\epsilon_x &= \frac{1}{2}KT = \frac{1}{2} \times 1.38 \times 10^{-23} \times 300 \\ &= 20.7 \times 10^{-22} \text{ J/molecule}\end{aligned}$$

For x -directional component,

$$\epsilon_x = \frac{h^2}{8ma^2} n_x^2$$

where a is the side of the cubical box.

$$\begin{aligned}n_x &= \frac{a}{h} [8 m \epsilon_x]^{1/2} \\ &= \frac{0.10}{6.625 \times 10^{-34}} \left[8 \times \frac{4}{6.023 \times 10^{-24}} \times 20.7 \times 10^{-22} \right]^{1/2} \\ &= 15.8 \times 10^{31}\end{aligned}$$

Ans.

Example 19.3 Calculate the number of ways of arranging seven distinguishable particles in four boxes so that $N_1 = 1$, $N_2 = 2$, $N_3 = 3$ and $N_4 = 1$.

Solution Eq. (19.40) applies to this case, so that

$$\begin{aligned}W &= \frac{N!}{\prod_i N_i!} = \frac{7!}{1! 2! 3! 1!} = \frac{7 \times 6 \times 5 \times 4}{2} \\ &= 420\end{aligned}$$

Ans.

Example 19.4 Calculate the number of ways of arranging six indistinguishable particles in four boxes which are (a) distinguishable, (b) indistinguishable.

Solution (a) Since the boxes are distinguishable,

$$\begin{aligned}W &= \frac{g_i (g_i + N_i - 1)!}{N_i!} = \frac{4(4 + 6 - 1)!}{6!} \\ &= \frac{4 \times 9 \times 8 \times 7 \times 6!}{6!} = 2016\end{aligned}$$

Ans.

$$\begin{aligned}
 &= \frac{(6.624 \times 10^{-34})^2}{8 \times 9.1 \times 10^{-31}} \left[\frac{3 \times 8.47 \times 10^{22} \times 10^6}{\pi} \right]^{2/3} \\
 &= 11.3 \times 10^{-19} \text{ J} \qquad \text{Ans.}
 \end{aligned}$$

Average electron energy at $T = 0 \text{ K}$,

$$\begin{aligned}
 \bar{\epsilon}_0 &= \frac{3}{5} \epsilon_{m_0} = \frac{3}{5} \times 11.3 \times 10^{-19} = 6.78 \times 10^{-19} \text{ J} \\
 \epsilon_0 &= \frac{3}{2} KT
 \end{aligned}$$

Equivalent gas temperature:

$$T = \frac{2\epsilon_0}{3K} = \frac{2 \times 6.78 \times 10^{-19}}{3 \times 1.38 \times 10^{-23}} = 32,8000 \text{ K} \qquad \text{Ans.}$$

(c) From Eq. (19.101),

$$\begin{aligned}
 C_v &= \frac{\pi^2 K T \bar{R}}{2 \epsilon_{m_0}} = \frac{\pi^2 \times 1.38 \times 10^{-23} \times 300 \bar{R}}{2 \times 11.3 \times 10^{-19}} \\
 &= 0.018 \bar{R} \qquad \text{Ans.}
 \end{aligned}$$

The electron contribution to specific heat is very small. For solids, the primary contribution to specific heat is by lattice vibration.

REVIEW QUESTIONS

- 19.1 What are the discrepancies of classical mechanics?
- 19.2 Explain the quantum theory of thermal radiation. What is quantum number?
- 19.3 What is the action integral of Bohr-Sommerfeld?
- 19.4 Explain the quantum principle applied to a system of particles.
- 19.5 What is the difference between the quantum view and continuum view?
- 19.6 Explain energy levels of particles, quantum states and degeneracy.
- 19.7 What do you mean by wave-particle duality? Explain how photons and electrons exhibit this duality.
- 19.8 What is de Broglie law? What does it signify?
- 19.9 Derive the wave equation of the transverse vibration of a stretched string.
- 19.10 How did Schrödinger apply the differential wave equation to the matter waves of de Broglie? What do you mean by time-dependent and time-independent Schrödinger wave equation?
- 19.11 What is probability distribution function? How does quantum mechanics basically differ from classical mechanics?
- 19.12 What is probability density? What is the normalization condition?
- 19.13 How are the discrete energy levels of a particle in a box derived with the help of Schrödinger wave equation?
- 19.14 What are degenerate and non-degenerate particles?
- 19.15 Give the discrete energy levels of a rigid rotator and a harmonic oscillator.

- 19.16 What do you mean by phase space? What are cells and compartments? How do they relate to energy levels and quantum states?
- 19.17 What is the significance of h^3 in phase space?
- 19.18 What are the constraints on the most probable distribution of particles in phase space?
- 19.19 Explain the terms: microstate, macrostate and thermodynamic probability.
- 19.20 Explain the statement: All microstates are equally probable.
- 19.21 Which macrostate refers to the thermodynamic equilibrium state?
- 19.22 Derive the thermodynamic probability for distinguishable particles based on Maxwell-Boltzmann statistics. How does the expression get altered for indistinguishable particles?
- 19.23 What is Stirling's approximation?
- 19.24 Show that the Maxwell-Boltzmann distribution function of particles among cells in phase space at equilibrium is given by:

$$N_i/g_i = 1/(B e^{\beta \epsilon_i})$$

where β is a constant.

- 19.25 Explain the physical model of Bose-Einstein statistics. Show that the number of microstates for a given macrostate of indistinguishable particles is given by:

$$W = \prod_i [(g_i + N_i - 1)! / (g_i - 1)! N_i!]$$

- 19.26 From the above relation of W , show that the Bose-Einstein distribution function is given by:

$$N_i/g_i = 1/[B e^{\beta \epsilon_i} - 1]$$

where B is a constant.

- 19.27 What is Pauli's exclusion principle? What are fermions?
- 19.28 Derive the expressions of thermodynamic probability and distribution function for Fermi-Dirac statistical model.
- 19.29 Give a comparison of M-B, B-E and F-D statistics.
- 19.30 What do you mean by partition function? What is the most probable distribution of the molecules in a gas among the possible energy levels?
- 19.31 Explain the relation of entropy with thermodynamic probability. Establish: $S = K \ln W$.
- 19.32 Why is second law called a law of probability?
- 19.33 Show that $\beta = 1/KT$.

- 19.34 Show that: (a) $U = NKT^2 \frac{d}{dT} \ln Z$,

$$(b) S = KN \left[\ln \frac{z}{N} + 1 \right] + \frac{U}{T}.$$

- 19.35 Show that the partition function of a monatomic ideal gas (or translational K.E.)

$$Z_{\text{trans}} = \frac{V}{h^3} [2\pi mKT]^{3/2}$$

- 19.36 Derive the Sackur-Tetrode equation for the absolute entropy of a monatomic ideal gas.
- 19.37 Establish the principle of equipartition of energy by showing that the energy associated with a particular coordinate being a quadratic function of that coordinate is equal to $1/2 KT$.

- 19.6 An argon atom (atomic weight 40) is moving between two walls 10 cm apart. If its quantum number is 10^8 , how much energy is required to change its quantum number to (a) $10^8 + 1$, (b) 10^9 ?
- 19.7 Consider a triatomic water molecule (atomic weight 18.02). It is contained in a cube of 10 cm side. Find the kinetic energy of the molecule if its translational quantum numbers are $n_x = 10^9$, $n_y = 10^{10}$ and $n_z = 10^{11}$. What are the wavelengths associated with each of the quantum numbers?
- 19.8 Calculate the rotational energy levels for a diatomic hydrogen molecule for the first five values of j (i.e., $j = 0, 1, 2, 3$, and 4). The mass of a hydrogen atom can be considered to be equal to that of a proton ($r = 0.742 \text{ \AA}$).
- 19.9 It is observed that light emitted from a rotating oxygen molecule must come from adjacent rotational states, i.e. $\Delta j = 1$. Determine the frequencies of the four lowest transitions if $I = 1.95 \times 10^{-39} \text{ g cm}^2$.
- 19.10 If an argon atom vibrates about an equilibrium location in simple harmonic motion, how much energy is required to change its vibrational quantum number from 10 to 11? Assume the constant K in the force acting on the atom $F = -K_x$ as 2 kN/m.
- 19.11 The equation of a translational system

$$\frac{n_x^2}{a^2} + \frac{n_y^2}{b^2} + \frac{n_z^2}{c^2} = \frac{8m\epsilon_i}{h^2}$$

is analogous to the equation of an ellipsoid

$$\frac{x^2}{a^2} + \frac{y^2}{b^2} + \frac{z^2}{c^2} = r^2,$$

where r^2 is identified as $(8m\epsilon_i)/h^2$. Realizing that only 1/8 of the volume of the ellipsoid is defined by positive values of the variables necessary to determine the number of states of energies between 0 and ϵ , prove that the number of states between ϵ and $\epsilon + d\epsilon$ is

$$g_i = \frac{4\pi m V}{h^3} [2m\epsilon_i]^{1/2} d\epsilon_i,$$

where V is the volume of the gas.

- 19.12 For a particle in a cubical box of side L , find the number of quantum states at each of the following energy levels:

$$(a) 12 \frac{h^2}{8mL^2}, (b) 25 \frac{h^2}{8mL^2} \text{ and } (c) 36 \frac{h^2}{8mL^2}$$

Ans. (a) 1, (b) 9, (c) 6

- 19.13 If a particle has a translational energy $3h^2/(8mL^2)$, what are the possible directions for its velocity?

Ans. 8

- 19.14 A particle with a mass of 10^{-23} g is moving in a small cubical box with edges of length 1 cm. Find the spacing between successive permissible values of the velocity components.
- 19.15 The uncertainty in the position of an electron is given by $\Delta x = 0.5 \text{ \AA}$. Determine the uncertainty, Δp , in the linear momentum of the electron. An electron is placed in a cubical box of side $a = 0.5 \text{ \AA}$. Estimate the lowest energy, E_0 , available to the electron.

Irreversible Thermodynamics

Classical thermodynamics deals with reversible processes in which transition of a system from one equilibrium state to another occurs. A system is said to be in equilibrium when no spontaneous change in the system takes place and all the thermodynamics properties remain constant and uniform throughout the system. The properties are spatial and time invariant. The branch of thermodynamics which deals with irreversible processes under steady state condition where the properties vary with space coordinates, but are constant with respect to time is known as *irreversible thermodynamics*. Denbigh called it *thermodynamics of the steady state*.

20.1 Entropy Flow and Entropy Production

Let us consider a thin copper rod connected between two heat reservoirs at temperatures T_1 and T_2 (Fig. 20.1). The rod is thermally insulated. Heat flows steadily from the hot to the cold reservoirs. The temperature varies from point to point along the rod, but the temperature at any point is constant with time. The temperature at a point is defined as the final equilibrium temperature of an isolated small volume element, enclosing the point in contact with the recording device, say, thermocouple. The volume element is small compared to the dimensions of the system, but large enough to avoid molecular fluctuations.

Let J_Q represent the rate of heat flow per unit area from the hot to the cold reservoir (W/m^2). In unit time, the hot reservoir undergoes an entropy decrease J_Q/T_1 ; the copper rod suffers no entropy change, because, once in the steady state, its coordinates do not change with time; and the cold reservoir undergoes an entropy increase J_Q/T_2 . So the entropy change of the universe per unit time is:

$$\Delta \dot{S}_{\text{universe}} = \Delta \dot{S}_{\text{Hot reservoir}} + \Delta \dot{S}_{\text{Rod}} + \Delta \dot{S}_{\text{Cold reservoir}}$$

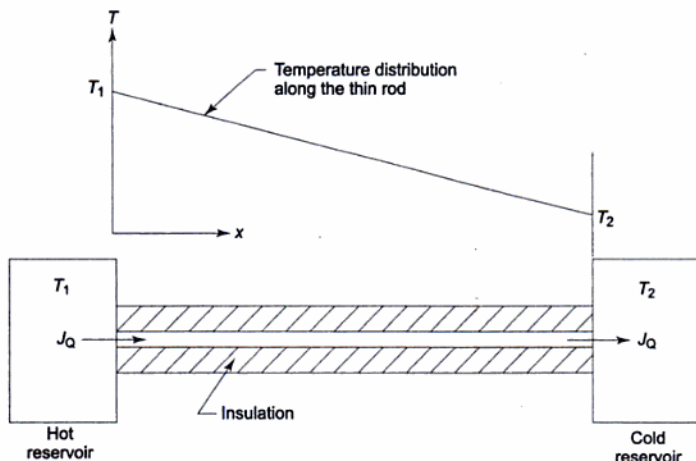

Fig. 20.1 *Steady irreversible flow of heat along a thin rod*

$$= \frac{J_Q}{T_1} + 0 + \frac{J_Q}{T_2} = J_Q \frac{T_1 - T_2}{T_1 T_2} \quad (20.1)$$

Let us focus our attention on the rod, rather than on the universe. Since the hot reservoir underwent an entropy decrease, it may be said that it *lost entropy to the rod*, or that there was a *flow of entropy into the rod* equal to J_Q/T_1 per unit time. Since the cold reservoir underwent an entropy increase, it may be said that the reservoir *gained entropy from the rod*, or that there was a *flow of entropy from the rod* equal to J_Q/T_2 per unit time. But since $J_Q/T_2 > J_Q/T_1$, the entropy outflux from the rod exceeds the entropy influx to the rod. The difference must have been generated within the rod due to irreversible heat transfer through a finite temperature difference. So the rate of entropy production, σ , within the rod is:

$$\sigma = \frac{dS}{dt} = \frac{J_Q}{T_2} - \frac{J_Q}{T_1} = J_Q \frac{T_1 - T_2}{T_1 T_2}$$

If $T_1 = T + \Delta T$ and $T_2 = T$, so that a small temperature difference exists across the rod,

$$\sigma = J_Q \frac{\Delta T}{T^2} \quad (20.2)$$

If J_S represents the entropy flow per unit time ($\text{W}/\text{m}^2\text{K}$), equal to J_Q/T ,

$$\sigma = J_S \frac{\Delta T}{T} \quad (20.3)$$

As $\Delta T \rightarrow 0$, $\sigma \rightarrow 0$, so that when the temperature difference vanishes, the rate of entropy production becomes zero, and the heat transfer process becomes

reversible. The rate of entropy production is thus a measure of the extent of irreversibility inherent in the process.

Let us now suppose that an electrical current J_1 (ampere/m²) is maintained in the same rod by virtue of a difference of potential ΔE across its ends, while the rod is in contact with a reservoir at temperature T (Fig. 20.2). Electrical energy of amount $J_1 \Delta E$ is dissipated in the rod per unit time, and at the same rate heat flows out of the rod, since at steady state the rod undergoes no energy change. There is an increase of entropy $(J_1 \Delta E)/T$ of the reservoir per unit time, while there is no entropy change of the rod. Therefore, the entropy change of the universe per unit time is $(J_1 \Delta E)/T$, which is positive. If we now focus our attention on the rod, it may be said that there was no flow of entropy into the rod, but that entropy flowed out at the rate $(J_1 \Delta E)/T$, which must have been produced internally. So, the rate of entropy production is:

$$\sigma = J_1 \frac{\Delta E}{T} \quad (20.4)$$

If now a temperature difference ΔT and a potential difference ΔE simultaneously exist across the rod with both the heat current and the electrical current flowing along the rod, the total rate of entropy generation would be:

$$\sigma = J_Q \frac{\Delta T}{T^2} + J_1 \frac{\Delta E}{T} = J_S \frac{\Delta T}{T} + J_1 \frac{\Delta E}{T} \quad (20.5)$$

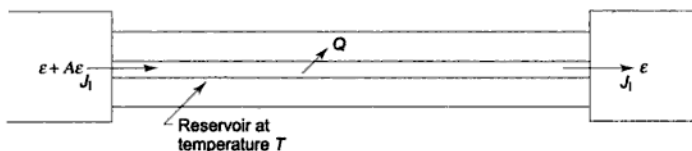

Fig. 20.2 Steady flow of electrical current in the rod

20.2 Onsager Equations

It has been found experimentally that in the absence of ΔE J_Q depends only on ΔT , but when there is a ΔE as well, then J_Q (and also J_S) depends on both ΔT and ΔE . Similarly, when both ΔT and ΔE exist across the rod, J_1 also depends on both of these differences. The heat flow and the electrical current flow are irreversible coupled flows, which exist because of the finite potentials across the rod. If the departure from equilibrium conditions in the rod is not too great, J_S and J_1 may be assumed to be linear functions of ΔT and ΔE , as given below

$$J_S = L_{11} \frac{\Delta T}{T} + L_{12} \frac{\Delta E}{T} \quad (20.6)$$

$$J_1 = L_{21} \frac{\Delta T}{T} + L_{22} \frac{\Delta E}{T} \quad (20.7)$$

where L 's are called *phenomenological coefficients*. The above equations are known as *Onsager equations*, which express the linearity between the fluxes and the forces. The L 's are coefficients connected with electrical resistance, thermal conductivity and the thermoelectric properties of the rod. Only three of the four L 's are independent, for it can be proved that, if the departure from equilibrium is not great,

$$L_{12} = L_{21} \quad (20.8)$$

This is known as *Onsager reciprocal relation*.

20.3 Phenomenological Laws

A large number of phenomenological laws exist, which describe the irreversible processes in the form of proportionalities, e.g. *Fourier's law* between heat flow and temperature gradient, *Fick's law* between flow of matter of a component in a mixture and its concentration gradient, *Ohm's law* between electrical current and potential gradient, *Newton's law* between shearing force and velocity gradient, the *chemical reaction law* between reaction rate and chemical potential. The causes which are responsible to the occurrence of these irreversible phenomena, such as, the temperature gradient, potential gradient, concentration gradient, and chemical affinity are called the *generalized forces*, denoted by $X_i (i = 1, 2, \dots, n)$. The irreversible phenomena, such as heat flow, electrical current flow, diffusion, chemical reaction rate, etc. caused by the *forces* are called *fluxes*, symbolized by $J_i (i = 1, 2, \dots, n)$. A thermodynamic force may be defined as a quantity which measures the extent to which the system is displaced from equilibrium.

When two or more of these phenomena occur simultaneously, they interfere and give rise to new effects. The examples of such cross-phenomena are:

(1) The two reciprocal phenomena of thermoelectricity arising from the interference of heat conduction and electrical conduction, viz., Seebeck effect and Peltier effect.

(2) The coupling of diffusion and heat conduction giving rise to *thermal diffusion*, called the *Soret effect* (concentration gradient formed as a result of a temperature gradient) and its inverse phenomenon, the *Dufour effect* (temperature difference arising when a concentration gradient exists).

Two coupled transport processes can be expressed in the generalized form

$$J_1 = L_{11}X_1 + L_{12}X_2 \quad (20.9)$$

$$J_2 = L_{21}X_1 + L_{22}X_2 \quad (20.10)$$

For two primary processes (say, heat conduction and flow of electricity) the basic or primary laws will be of the form:

$J_1 = L_{11}X_1$, for process 1 alone, say, heat conduction, where $J_1 = J_Q$, $X_1 = dT/dx$ and L_{11} is the thermal conductivity, and,

$J_2 = L_{22}X_2$, for process 2 alone, say electrical flow, where $J_2 = J_1$, $X_2 = dE/dx$ and L_{22} is the electrical conductivity.

If process 2 influences process 1 and vice versa,

$J_1 = L_{12}X_2$ (the quantity of heat flow J_1 due to electrical potential X_1);

$J_2 = L_{21}X_1$ (the electrical current flow J_2 due to temperature gradient X_2).

The latter two processes are called coupled processes, and the coefficients L_{12} and L_{21} are called *coupling coefficients*. The first digit in the subscripts of the L 's refers to the flux and the second digit refers to the force. If $L_{12} = L_{21} = 0$, the fluxes are dependent only on the primary forces and are uncoupled.

20.4 Rate of Entropy Generation: Principle of Superposition

The rate of entropy generation is the product of forces and fluxes. From Eq. (20.5),

$$\begin{aligned}\sigma &= J_Q \frac{\Delta T}{T^2} + J_1 \frac{\Delta E}{T} = J_S \frac{\Delta T}{T} + J_1 \frac{\Delta E}{T} \\ &= J_1 X_1 + J_2 X_2\end{aligned}\quad (20.11)$$

where

$$J_1 = J_Q \text{ or } J_S, J_2 = J_1, X_1 = \frac{\Delta T}{T^2}$$

or $\frac{\Delta T}{T}$ and $X_2 = \frac{\Delta E}{T}$

The rate of entropy generation in irreversible steady state coupled processes is thus the sum of the entropy generation for each of the processes, i.e.

$$\sigma = J_1 X_1 + J_2 X_2 + J_3 X_3 + \dots \quad (20.11a)$$

This is known as the *principle of superposition* as stated by Verschaffelt (Prigogine, 1961).

Let us consider a control volume (Fig. 20.3) in which the properties vary from point to point and with time. The internal energy:

$$u = f(x, y, z, t)$$

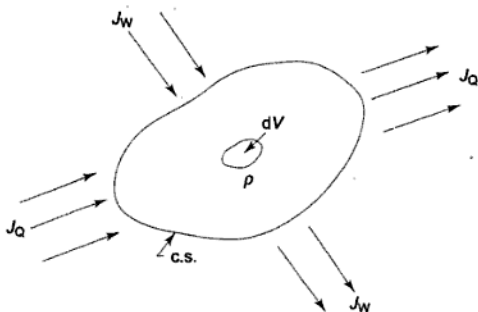

Fig. 20.3 Heat and work flow in a control volume

$$\text{or,} \quad \text{div } J_W = E \text{ div } J_1 + J_1 \text{ grad } E$$

By Kirchhoff's law, $\text{div } J_1 = 0$

$$\text{div } J_W = J_1 \text{ grad } E$$

By substituting in Eq. (20.19),

$$\text{Therefore,} \quad \rho \frac{\partial u}{\partial t} = -\text{div } J_Q - J_1 \text{ grad } E$$

$$\rho \frac{\partial s}{\partial t} = -\frac{\text{div } J_Q}{T} - \frac{J_1 \text{ grad } E}{T}$$

$$= -\text{div } \frac{J_Q}{T} - J_Q \frac{\text{grad } T}{T^2} - \frac{J_1 \text{ grad } E}{T}$$

$$\rho \frac{\partial s}{\partial t} + \text{div } J_S = -J_Q \frac{\text{grad } T}{T^2} - J_1 \frac{\text{grad } E}{T}$$

Therefore, from Eq. (20.16),

$$\sigma = -J_Q \frac{\text{grad } T}{T^2} - J_1 \frac{\text{grad } E}{T} \quad (20.20)$$

20.4.3 Entropy Generation due to Heat and Mass Flows

For a system of variable composition Gibbs entropy equation is given by:

$$T ds = dU + p dV - \sum \mu_k dm_k$$

or per unit mass

$$T ds = du + p dv - \sum \mu_k dc_k$$

where $c_k = m_k/m$ = mass fraction of component k and μ_k is the chemical potential of component k .

Let us consider a region of fixed volume and mass in a motionless fluid mixture. Then,

$$T ds = du - \sum \mu_k dc_k$$

$$\text{or} \quad T \frac{ds}{dt} = \frac{du}{dt} - \sum \mu_k \frac{dc_k}{dt} \quad (20.21)$$

For the control volume (Fig. 20.4), the continuity equation for the component k gives:

$$\frac{d}{dt} \int_V (\rho dV) c_k = - \int_A J_k dA = - \int_V \text{div } J_k dV$$

where J_k is the rate of flow of substance k per unit area of the surface.

Therefore,

$$\rho \frac{dc_k}{dt} + \text{div } J_k = 0 \quad (20.22)$$

$$\left[\frac{J_S}{J_I} \right]_{T=c} = \frac{L_{12}}{L_{22}} = S^* \quad (20.43)$$

$$L_{12} = L_{22} S^* = \lambda T S^* \quad (20.44)$$

The ratio of the heat flux to the electric current at constant temperature is called the *heat of transport*, Q^* , the heat transported by the current. From Eqs (20.35) and (20.42)

$$\left[\frac{J_Q}{J_I} \right]_{T=c} = T \frac{L_{12}}{L_{22}} = Q^* \quad (20.45)$$

or, $L_{12} = \lambda Q^*$ (20.46)

From Eqs (20.44) and (20.46),

$$Q^* = T S^* \quad (20.47)$$

From Eq. (20.40),

$$\begin{aligned} L_{11} &= k + \frac{L_{12}^2}{L_{22}} = k + \frac{(\lambda T S^*)^2}{T} \\ &= k + \lambda T S^{*2} \end{aligned} \quad (20.48)$$

Substituting the expressions of L_{11} , L_{12} , L_{21} and L_{22} in the equations (20.31 to 20.33),

$$J_S = - \frac{k + \lambda T S^*}{T} \frac{dT}{dx} - \lambda S^* \frac{dE}{dx} \quad (20.49)$$

$$J_I = - \lambda S^* \frac{dT}{dx} - \lambda \frac{dE}{dx} \quad (20.50)$$

$$J_Q = - [k + \lambda T S^{*2}] \frac{dT}{dx} - \lambda T S^* \frac{dE}{dx} \quad (20.51)$$

These are the *governing equations of thermoelectricity*.

20.6.1 Thermocouple

A thermocouple is a device for recording the temperature at a point within a system (Fig. 20.5).

Seebeck Effect Two wires of dissimilar materials A and B , such as copper and constantan, are joined together, say by soldering, to form the hot junction a , which is kept in contact with the system whose temperature is to be measured. The ends b and c are connected to the leads of the material D (often copper). The joints b and c are immersed in an ice bath to form the cold junction. The leads are connected to a potentiometer at d and e . When the temperature at the hot junction T_H is different from the temperature at the cold junction T_c , an electric current

From Eqs (20.45) and (20.47), the rate at which heat is transported into the junction by the current J_1 is:

$$(J_Q)_A = J_1 Q_A^* = J_1 T S_A^*$$

and the rate at which heat is transported out of the junction by the current is:

$$(J_Q)_B = J_1 Q_B^* = J_1 T S_B^*$$

At steady state, from the first law,

$$\begin{aligned} J'_Q &= \frac{I^2 R_j}{A} + (J_Q)_A - (J_Q)_B \\ &= \frac{I^2 R_j}{A} + J_1 T (S_A^* - S_B^*) \end{aligned} \quad (20.55)$$

$\left[J'_Q - \frac{I^2 R_j}{A} \right]$ is the rate at which excess heat is to be removed per unit area, over and above the Joulean heat $\frac{I^2 R_j}{A}$, to keep the junction isothermal, and is called the *Peltier heat*. Therefore,

$$\text{Peltier heat} = J_1 T (S_A^* - S_B^*)$$

The *Peltier heat* (W/m^2) is proportional to the current J_1 and the constant of proportionality is called the *Peltier coefficient*, π .

Therefore,

$$\pi_{A,B} = T[S_A^* - S_B^*] \quad (20.56)$$

The Peltier coefficient is called the *Peltier emf*, since its unit is volts. The Peltier emf at a junction depends on temperature and the materials of the junction.

If Ohmic (or Joulean) heating is neglected, then Eq. (20.55) reduces to:

$$J'_Q = J_1 T [S_A^* - S_B^*] = J_1 \pi_{A,B} \quad (20.57)$$

If the current is reversed, in direction (Fig. 22.7),

$$\begin{aligned} J'_Q &= (J_Q)_B - (J_Q)_A = J_1 T (S_B^* - S_A^*) \\ &= -\pi_{A,B} J_1 \end{aligned} \quad (20.58)$$

Peltier heat is, therefore, absorbed in the junction to keep it isothermal at temperature T . *Peltier effect is thus reversible.*

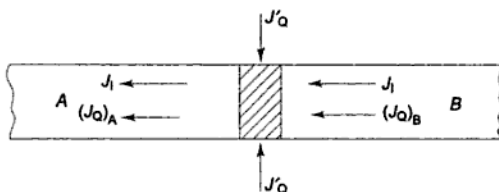

Fig. 20.7 Reversal of current in the junction of dissimilar materials

Thomson Effect Let us consider an element of length Δx of a rod or a wire through which heat is flowing steadily by conduction due to a temperature difference ΔT (Fig. 20.8). If an electric current I is sent through the element, it is found that the temperature distribution in the element is altered by an amount that is not entirely due to Joule effect. The rate, at which the electrical energy is dissipated into internal energy increase of the element, is greater or less than the $I^2 R$ heating, the difference depending on the magnitude and direction of the current, on the temperature, and on the material. This phenomenon is known as the *Thomson effect*. Allowing for Joule effect, the heat that must be supplied or extracted laterally at all places along the element to restore the initial temperature distribution (without electric current) is called the *Thomson heat*.

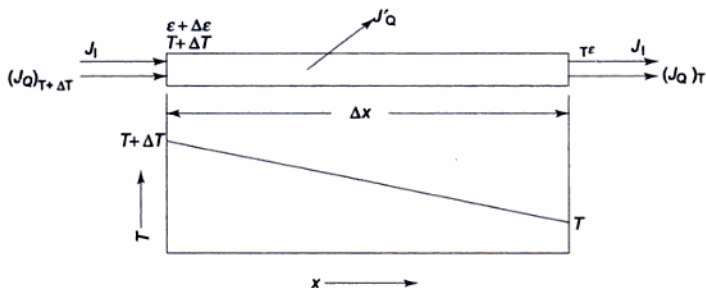

Fig. 20.8 Coupled flow of heat and electricity in an element

Let J'_Q represent the heat that must be removed laterally per unit area in unit time from the element carrying a current to restore the element to its original temperature distribution. If ΔE is the potential difference across the element, the rate at which electrical work is done on the element is $I\Delta E$. The rate at which heat is transported per unit area by the electrical current into the element is $(J_Q)_{T+\Delta T} = J_I(Q^*)_{T+\Delta T}$, and the rate at which heat is transported by the current out of the element per unit area is $(J_Q)_T = J_I(Q^*)_T$, both in kW/m^2 . The conduction heat flowing into and out of the element is the same and need not be considered here. By first law,

$$\begin{aligned} J'_Q &= J_I \Delta E + J_I(Q^*)_{T+\Delta T} - J_I(Q^*)_T \\ &= J_I [\Delta E + (T + \Delta T)(S^*)_{T+\Delta T} - TS^*] \end{aligned}$$

Now,
$$(S^*)_{T+\Delta T} = S^* + \frac{dS}{dT} \Delta T$$

Therefore,

$$J'_Q = J_I \left[\Delta E + TS^* + T \frac{dS^*}{dT} \Delta T + S^* \Delta T \right]$$

$$\left. + \frac{dS^*}{dT} (\Delta T)^2 - T S^* \right]$$

$$\text{or } J'_Q = J_I \left[\Delta E + T \frac{dS^*}{dT} \Delta T + S^* \Delta T \right] \quad (20.59)$$

neglecting the small quantity $\frac{dS^*}{dT} (\Delta T)^2$.

From Eq. (20.50),

$$J_I = -\lambda S^* \frac{dT}{dx} - \lambda \frac{dE}{dx}$$

$$\text{or } \frac{dE}{dx} = -\frac{J_I}{\lambda} - S^* \frac{dT}{dx}$$

Also,

$$\begin{aligned} \Delta E &= -\frac{dE}{dx} \Delta x = \frac{J_I}{\lambda} \Delta x + S^* \frac{dT}{dx} \Delta x \\ &= \frac{J_I}{\lambda} \Delta x - S^* \Delta T \end{aligned} \quad (20.60)$$

Substituting ΔE in Eq. (20.59),

$$\begin{aligned} J'_Q &= J_I \left[\frac{J_I}{\lambda} \Delta x - S^* \Delta T + T \frac{dS^*}{dT} \Delta T + S^* \Delta T \right] \\ &= \frac{J_I^2}{\lambda} \Delta x + J_I T \frac{dS^*}{dT} \Delta T \end{aligned} \quad (20.61)$$

The current density J_I is given by

$$J_I = -\lambda \frac{dE}{dx} = \lambda \frac{\Delta E}{\Delta x}$$

Therefore, the Joulean heat per unit area is:

$$J_I \Delta E \cdot J_I = \frac{J_I \Delta x}{\lambda} = \frac{J_I^2}{\lambda} \Delta x$$

From Eq. (20.61),

$$J'_Q - \frac{J_I^2}{\lambda} \Delta x = J_I T \frac{dS^*}{dT} \Delta T \quad (20.62)$$

This is the excess heat that must be removed per unit area from the element laterally, over and above the Joulean heat, and is the *Thomson heat*. The quantity $T \frac{dS^*}{dT} \Delta T$ is expressed in volts and is called the *Thomson emf*. Thomson heat is proportional to J_I as well as ΔT and the constant of proportionality is called the *Thomson coefficient*, σ . If heat is added to keep the same temperature, σ is positive. If heat is removed, σ is negative. So,

$$\sigma = -T \frac{dS^*}{dT} \quad (20.63)$$

The Eq. (20.62) becomes

$$J_Q' - \frac{J_1^2}{\lambda} \Delta x = -\sigma J_1 \Delta T \quad (20.64)$$

The difference in Thomson coefficients for the two wires A and B in the thermocouple

$$\sigma_A - \sigma_B = -T \frac{d}{dT} [S_A^* - S_B^*] \quad (20.65)$$

Thus, all the thermoelectric effects can be expressed in terms of the entropy transport parameter S^* and the temperature, as given below:

Seebeck effect:
$$E_{A,B} = \int_{T_C}^{T_H} [S_A^* - S_B^*] dT$$

Peltier effect:
$$\pi_{A,B} = T [S_A^* - S_B^*]$$

Thomson effect:
$$\sigma_A - \sigma_B = -T \frac{d}{dT} [S_A^* - S_B^*]$$

Differentiating $E_{A,B}$ with respect to T ,

$$\frac{dE_{A,B}}{dT} = S_A^* - S_B^*$$

and
$$\frac{d^2 E_{A,B}}{dT^2} = \frac{d}{dT} [S_A^* - S_B^*]$$

Therefore,

$$\pi_{A,B} = T \frac{dE_{A,B}}{dT} \quad (20.66)$$

and
$$\sigma_A - \sigma_B = -T \frac{d^2 E_{A,B}}{dT^2} \quad (20.67)$$

The above equations are known as *Thomson's first and second relations*, which were derived by Thomson (Lord Kelvin) by a different procedure. If for a given thermocouple, the relationship between the emf and the temperature is known, e.g.,

$$E_{A,B} = \alpha_1 t, \alpha_2 t^2 + \alpha_3 t^3$$

where t is the Celsius temperature and the α 's are constants depending on the materials, then both the Peltier coefficient of any junction and the difference in Thomson coefficients of the two wires at any temperature can be computed.

The Seebeck emf of a thermocouple can also be expressed in terms of the Peltier emf's at the junctions and the Thomson's emf's in the wires, as given below:

$$\left[\frac{\Delta p}{\Delta T} \right]_{J_M=0} = \frac{h - L_{12}/L_{11}}{vT} \quad (20.75)$$

This quotient is called the *thermomolecular pressure difference*. A temperature difference between the two vessels causes matter to flow thus setting up a pressure difference.

The thermomechanical effect may be connected with thermomolecular pressure difference from Eqs. (20.74) and (20.75),

$$\left[\frac{\Delta p}{\Delta T} \right]_{J_M=0} = \frac{h - U^*}{vT} = - \frac{Q^*}{vT} \quad (20.76)$$

where $Q^* = U^* - h$ called the *heat of transfer*.

The above equation is very important in the thermodynamics of irreversible processes, some applications of it being given below.

20.7.1 Knudsen Gas

Let us consider an ideal gas contained in a vessel divided into two parts by a capillary whose diameter is small compared to the mean free path of gas molecules (Fig. 20.10). Every molecule arriving at the hole of the capillary will pass through it freely.

The rms velocity of a molecule passing through the capillary is $[(4KT)/m]^{1/2}$, instead of $[(3KT)/m]^{1/2}$ (see Lee, Sears and Turcotte, 1973). Therefore, the mean energy of the molecule is:

$$\frac{1}{2} m v_{\text{rms}}^2 = \frac{1}{2} m \frac{4K \cdot T}{m} = 2KT$$

The energy transferred with each unit of mass is

$$U^* = 2KT = 2 \frac{\bar{R}}{\mu} T, \quad (20.77)$$

where μ is the molecular weight.

The enthalpy of a monatomic ideal gas is

$$h = u + pv = \frac{3}{2} \frac{\bar{R}}{\mu} T + \frac{\bar{R}}{\mu} T = \frac{5}{2} \frac{\bar{R}}{\mu} T$$

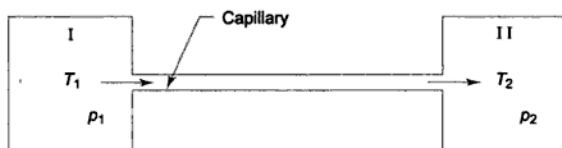

Fig. 20.10 Two vessels connected by a capillary

Therefore, from Eq. (20.76),

$$\frac{\Delta p}{\Delta T} = \frac{\frac{5}{2} \frac{\bar{R} T}{\mu} - 2 \frac{\bar{R} T}{\mu}}{v T} = \frac{1}{2} \frac{\bar{R}}{\mu v} = \frac{1}{2} \frac{p}{T}$$

which leads to

$$p_1/p_2 = [T_1/T_2]^{1/2} \quad (20.78)$$

20.7.2 Ordinary Ideal Gas

If the diameter of the hole is large in comparison with the mean free path, the energy transferred with an element of gas is the whole energy of the gas or its enthalpy, so that

$$U^* = h$$

or, $\Delta p/\Delta T = 0$ or $p_1 = p_2$

Thus, there is no thermomechanical effect for an ideal gas under ordinary conditions.

20.7.3 Other Applications

A temperature gradient giving rise to a pressure gradient and mass transfer is also demonstrated in *fountain effect*, in which liquid helium below the λ -point (2.18 K) upon being heated flow from vessel 1 to vessel 2. The same effect manifests itself in gases or liquids when a membrane separates the two vessels. A difference in concentration (or Δp) arises as a result of temperature difference. It is called *thermo-osmosis*.

20.8 Stationary States

In the domain of irreversible thermodynamics, a stationary state is defined as the state of a system when all the thermodynamic properties of the system get independent of time.

All natural processes are characterized by certain forces X_1, X_2, \dots, X_n and fluxes J_1, J_2, \dots, J_n . Let us fix a number k of these forces, viz., X_1, X_2, \dots, X_k at constant values by means of external constraints. The remaining forces $X_{k+1}, X_{k+2}, \dots, X_n$ are kept free. The system will undergo a natural evolution till the free forces are destroyed and finally arrive in a state of minimum entropy production compatible with the constraints imposed. Thus we have,

$$\left[\frac{\partial \sigma}{\partial x_i} \right]_{x_1, x_2, \dots, x_k} = 0 \quad (\text{where } i = k+1, k+2, \dots, n)$$

We call this state as the stationary state of k -th order. Since σ is a quadratic function of X 's, it can be proved that when k 's of the forces are kept fixed, the flux $J_{k+1}, J_{k+2}, \dots, J_n$ vanish.

SOLVED EXAMPLES

Example 20.1 Show that in the case of irreversible coupled flows of heat and electricity.

$$(a) \quad T^2 \sigma = L_{11}(\Delta T)^2 + (L_{12} + L_{21}) \Delta T \Delta E + L_{22} (\Delta E)^2$$

$$(b) \quad \frac{\partial}{\partial \Delta E} (T\sigma)_{\Delta T} = 2J_1, \quad \frac{\partial}{\partial \Delta T} (T\sigma)_{\Delta E} = 2J_2$$

(c) Show that with ΔT fixed, the equilibrium state obtained when $J_1 = 0$ involves a minimum rate of entropy production.

(d) Show that with ΔE fixed, the equilibrium state obtained when $J_2 = 0$ involves a minimum rate of entropy production.

Solution

From Eqs (20.6) and (20.7),

$$J_2 = L_{11} \frac{\Delta T}{T} + L_{12} \frac{\Delta E}{T}$$

$$J_1 = L_{21} \frac{\Delta T}{T} + L_{22} \frac{\Delta E}{T}$$

From Eq. (20.11),

$$\sigma = J_2 \frac{\Delta T}{T} + J_1 \frac{\Delta E}{T}$$

$$T^2 \sigma = J_2 T \Delta T + J_1 T \Delta E$$

$$= \left[L_{11} \frac{\Delta T}{T} + L_{12} \frac{\Delta E}{T} \right] T \Delta E$$

$$+ \left[L_{21} \frac{\Delta T}{T} + L_{22} \frac{\Delta E}{T} \right] T \Delta E$$

$$= L_{11}(\Delta T)^2 + (L_{12} + L_{21}) \Delta T \Delta E + L_{22}(\Delta E)^2 \quad \text{Proved}$$

(a).

From Eq. (20.11),

$$T\sigma = J_2 \Delta T + J_1 \Delta E$$

$$\frac{\partial}{\partial \Delta E} (T\sigma)_{\Delta T} = \Delta T \left[\frac{\partial J_2}{\partial \Delta E} \right]_{\Delta T} + J_1 + \Delta E \left[\frac{\partial J_1}{\partial \Delta E} \right]_{\Delta T}$$

$$= \Delta T \frac{L_{12}}{T} + J_1 + \Delta E \frac{L_{22}}{T}$$

$$= \left[L_{21} \frac{\Delta T}{T} + L_{22} \frac{\Delta E}{T} \right] + J_1$$

$$= J_1 + J_1 = 2J_1$$

Proved (b).

Similarly,

$$\frac{\partial}{\partial \Delta T} (T\sigma)_{\Delta E} = J_2 + \Delta T \left[\frac{\partial J_2}{\partial \Delta T} \right]_{\Delta E} + \Delta E \left[\frac{\partial J_1}{\partial \Delta T} \right]_{\Delta E}$$

$$\begin{aligned}
 &= J_S + \Delta T \frac{L_{11}}{T} \Delta E \frac{L_{21}}{T} \\
 &= J_S + J_S = 2J_S
 \end{aligned}$$

Proved (b).

From (a),

$$\sigma = \frac{L_{11}(\Delta T)^2}{T^2} + 2L_{12} \frac{\Delta T \Delta E}{T^2} + L_{22} \frac{(\Delta E)^2}{T^2}$$

For minimum rate of entropy production,

$$\left[\frac{\partial \sigma}{\partial \Delta E} \right]_{\Delta T} = 0 + 2L_{12} \frac{\Delta T}{T^2} + 2 \frac{L_{22}}{T^2} \Delta E = 0$$

$$\therefore L_{12} = -L_{22} \frac{\Delta E}{\Delta T}$$

Substituting in Eq. (20.7),

$$J_1 = -L_{22} \frac{\Delta E}{\Delta T} \frac{\Delta T}{\Delta} + L_{22} \frac{\Delta E}{T} = 0 \quad \text{Proved (c).}$$

Again,

$$\left[\frac{\partial \sigma}{\partial \Delta T} \right]_{\Delta E} = 2 \frac{L_{11}}{T^2} \Delta T + 2L_{12} \frac{\Delta E}{T^2} + 0 = 0$$

$$L_{11} = -L_{12} \frac{\Delta E}{\Delta T}$$

Substituting in Eq. (20.6),

$$J_S = -L_{12} \frac{\Delta E}{\Delta T} \frac{\Delta T}{T} + L_{12} \frac{\Delta E}{T} = 0 \quad \text{Proved (d).}$$

Example 20.2 The difference between Seebeck coefficients for bismuth and lead is given by

$$-43.7 \text{ } (\mu\text{V/deg}) - 0.47 \text{ } (\mu\text{V/deg}^2)t$$

where t is in $^{\circ}\text{C}$.

(a) Calculate the emf of a Bi-Pb thermocouple with the reference junction at $^{\circ}\text{C}$ and the test junction at 100°C . (b) What is the Peltier coefficient of the test junction at 100°C ? What Peltier heat would be transferred at this junction by an electric current of 10 amperes in 5 min? Would this heat go into or out of the junction? (c) What is the difference between the Thomson coefficients at points at 50°C ?

Solution

$$(a) \quad S_A^* - S_B^* = -43.7 - .47t$$

$$E_{A,B} = - \int_0^{100} [43.7 + 0.47t] dt$$

where t is in $^{\circ}\text{C}$, $\alpha_1 = -5.991 \times 10^{-6}$, $\alpha_2 = -0.036 \times 10^{-6}$, $\alpha_3 = 5 \times 10^{-12}$. Calculate (a) the Peltier heat transferred at a junction at (i) 1000°C , (ii) 500°C by a current of 0.001 amp in one hour, (b) the temperature at which Peltier heat is zero, and (c) the difference in Thomson coefficients at the above temperatures.

Solution

$$E_{E_{A,B}} = \int [S_A^* - S_B^*] dT$$

$$\frac{dE_{A,B}}{dT} = S_A^* - S_B^*$$

$$\pi_{A,B} = T \frac{dE_{A,B}}{dT} = T[S_A^* - S_B^*]$$

Given:
$$E = \alpha_1(T - 273) + \frac{\alpha_2}{2}(T - 273)^2 + \frac{\alpha_3}{3}(T - 273)^3$$

$$\frac{dE}{dT} = \alpha_1 + \alpha_2(T - 273) + \alpha_3(T - 273)^2$$

$$\pi_{A,B} = 1273 [-5.991 \times 10^{-6} - 0.036 \times 10^{-6} \times 1000 + 5 \times 10^{-12} \times (1000)^2] = -0.047 \text{ volt}$$

Peltier heat at $1000^{\circ}\text{C} = \pi_{A,B} Jt = 0.047 \times 0.001 \times 3600 = -0.169 \text{ J}$

Ans. (a)

At 500°C ,

$$\pi_{A,B} = -0.0286 \text{ volt}$$

Peltier heat = $-0.0286 \times 0.001 \times 3600 = -0.103 \text{ J}$

Ans. (a)

When $\pi_{A,B} = 0$,

$$T(\alpha_1 + \alpha_2 t + \alpha_3 t^2) = 0$$

$$\text{or } \alpha_1 + \alpha_2 t + \alpha_3 t^2 = 0$$

$$t = \frac{-\alpha_2 \pm [\alpha_2^2 - 4\alpha_1\alpha_3]^{1/2}}{2\alpha_3}$$

$$= \frac{0.036 \times 10^{-6} \pm \left[(0.036 \times 10^{-6})^2 - 4 \times (-5.991 \times 10^{-6}) (5 \times 10^{-12}) \right]^{1/2}}{2 \times 5 \times 10^{-12}}$$

$$= \frac{0.036 \times 10^{-6} \pm [1.296 \times 10^{-15} + 119.82 \times 10^{-18}]^{1/2}}{10^{-11}}$$

$$= \frac{0.036 \times 10^{-6} + 37.63 \times 10^{-9}}{10^{-11}}$$

$$= \frac{(0.036 \pm 0.037) \times 10^{-6}}{10^{-11}} = 0.073 \times 10^5$$

ε = degree of reaction,

A = chemical affinity = $[v_3\mu_3 + v_4\mu_4 - [v_1\mu_1 + v_2\mu_2]]$ or $[v_1\mu_1 + v_2\mu_2] - [v_3\mu_3 + v_4\mu_4]$.

- 20.14 What will be the entropy generation for multiple forces (temperature gradient, electric potential gradient, concentration gradient and chemical affinity) simultaneously existing in a system?
- 20.15 Why is Onsager's reciprocal relation often called the fourth law of thermodynamics?
- 20.16 What do you mean by entropy of transport?
- 20.17 Establish the governing equations of thermo-electricity as given below:

$$J_S = - \frac{k + \lambda TS^{*2}}{T} \frac{dT}{dx} - \lambda S^* \frac{dE}{dx}$$

$$J_I = - \lambda S^* \frac{dT}{dx} - \lambda \frac{dE}{dx}$$

$$J_Q = - [k + \lambda TS^{*2}] \frac{dT}{dx} - \lambda TS^* \frac{dE}{dx}$$

- 20.18 Explain the "Seebeck effect". Show that the Seebeck emf is given by:

$$E_{A,B} = \int_{T_C}^{T_H} [S_B^* - S_A^*] dT$$

- 20.19 What is thermoelectric power of a thermocouple? Show that it is given by the difference of the entropy transport parameters of the two wires.
- 20.20 Explain what you understand by Peltier effect. What is Peltier heat?
- 20.21 Show that the Peltier emf is given by:

$$\pi_{A,B} = T[S_A^* - S_B^*]$$

- 20.22 Show that Peltier effect is reversible.
- 20.23 Explain Thomson effect. What is Thomson heat?
- 20.24 Show that the Thomson emf is given by $T \frac{dS^*}{dT} \Delta T$.
- 20.25 Show that the difference in Thomson coefficients for the two wires A and B is given by

$$\sigma_A - \sigma_B = T \frac{d}{dT} [S_A^* - S_B^*]$$

- 20.26 Establish Thomson's first and second relations of thermoelectricity as given below:

$$\pi_{A,B} = \frac{dE_{A,B}}{dT}$$

$$\sigma_A - \sigma_B = - T \frac{d^2 E_{A,B}}{dT^2}$$

Kinetic Theory of Gases and Distribution of Molecular Velocities

The kinetic theory of gases attempts to explain the macroscopic properties of a gas in terms of the motion of its molecules. The gas is assumed to consist of a large number of identical, discrete particles called molecules, a molecule being the smallest unit having the same chemical properties as the substance.

21.1 Molecular Model

The kinetic theory is based on certain assumptions regarding the molecular nature of the gas.

1. Any finite volume of a gas consists of a very large number of molecules. The number of molecules in 1 kgmol of a gas is 6.023×10^{26} , which is the Avogadro's number N_0 . At standard conditions of 760 mm Hg and 0°C , 1 kgmol of gas has a volume of 22.4 m^3 , so that there are approximately 3×10^{16} molecules in 1 mm^3 of volume.
2. The molecules are like identical hard spheres moving about continuously in random directions. They are separated from one another by distances about 10 times the molecular diameter (2 to $3 \times 10^{-10} \text{ m}$).
3. The molecules move only in straight line paths, the directions of which change only by collisions.
4. Collisions of molecules are perfectly elastic, so that there is no decrease in kinetic energy during a collision.
5. The molecules are distributed uniformly throughout the container. If there are N molecules in a container of volume V , the average number of molecules per unit volume, n , is equal to N/V and $dN = n dV$, where the

volume element dV is small compared to the dimensions of the container, but large enough to contain many molecules.

6. All directions of molecular velocities are equally probable.

21.2 Distribution of Molecular Velocities in Direction

Let us imagine that to each molecule is attached a vector representing the magnitude and direction of its velocity. When all these velocity vectors are transferred to a common origin, we have a distribution in velocity space (Fig. 21.1). Let us now construct a sphere of arbitrary radius r with its centre at the origin (Fig. 21.2). The velocity vectors, extended if necessary, intersect the surface of the sphere at as many points as there are molecules. The average number of these velocity points per unit area is $N/(4\pi r^2)$. An element of area on the surface of the sphere of radius r in an arbitrary direction specified with reference to a polar coordinate system by the angle θ and ϕ (Fig. 21.2) is given by:

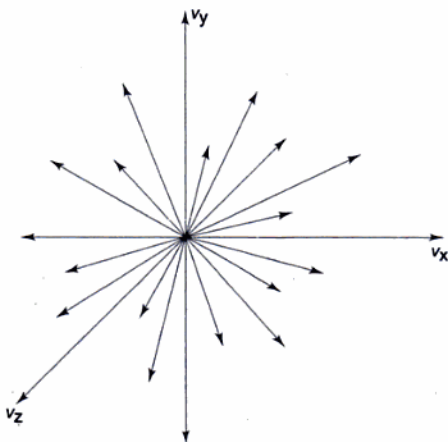

Fig. 21.1 Velocity vectors of molecules in velocity space

$$dA = r^2 \sin \theta \cdot d\theta \cdot d\phi$$

The number of molecules having velocities in a direction between θ and $\theta + d\theta$ and ϕ and $\phi + d\phi$, which is denoted by $d^2N_{\theta\phi}$, is

$$\begin{aligned} d^2N_{\theta\phi} &= \frac{N}{4\pi r^2} r^2 \sin \theta \cdot d\theta \cdot d\phi \\ &= \frac{N}{4\pi} \sin \theta \cdot d\theta \cdot d\phi \end{aligned} \quad (21.1)$$

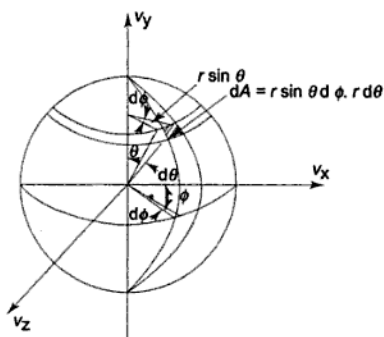

Fig. 21.2 Elemental area on the surface of a sphere in velocity space

When we divide the two sides of the equation by volume V and substitute $n = N/V$, we get:

$$d^2 n_{\theta\phi} = \frac{n}{4\pi} \sin \theta \cdot d\theta \cdot d\phi \quad (21.2)$$

The magnitude of the molecular velocity is the speed. Not all the molecules have the same speed. The speed of the molecules can vary from zero to the speed of light. However, for mathematical convenience, we will assume the molecular speed varying from zero to infinity.

21.3 Molecular Collisions with a Stationary Wall

Any surface in contact with a gas is constantly bombarded by the gas molecules from all directions and with all speeds. Let us consider the area dA of such a surface (Fig. 21.3) with the angles θ and ϕ so specified. The number of molecules travelling in the $\theta\phi$ direction and with a certain velocity v are designated by $dn_{\theta\phi v}$. The collision of any one of these molecules with area dA is called a $\theta\phi v$ collision. The slanted cylinder (Fig. 21.3) has edges in the direction θ , ϕ and a length $v dt$, equal to the distance travelled in the $\theta\phi$ direction with speed v . The number of $\theta\phi v$ collisions with area dA in time dt equals the number of $\theta\phi v$ molecules in this volume.

Let dn_v represent the number of molecules per unit volume with speeds between v and $v + dv$. From Eq. (21.2), the number of $\theta\phi v$ molecules per unit volume is:

$$d^3 n_{\theta\phi v} = \frac{1}{4\pi} dn_v \sin \theta \cdot d\theta \cdot d\phi$$

The volume of the cylinder is:

$$dV = dA v dt \cos \theta$$

The number of $\theta\phi v$ molecules in the cylinder, and hence, the number of $\theta\phi v$ collisions with area dA in time dt , is:

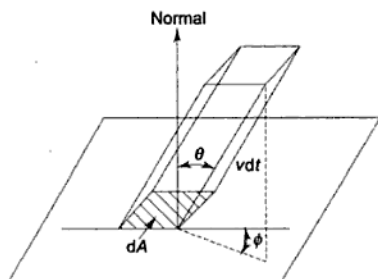

Fig. 21.3 $\theta\phi v$ collision of molecules with a wall

$$d^3n_{\theta\phi v} dV = \frac{v dA dt}{4\pi} dn_v \sin \theta \cdot \cos \theta \cdot d\theta \cdot d\phi$$

The number of collisions per unit area and per unit time is

$$\frac{1}{4\pi} v dn_v \sin \theta \cos \theta d\theta d\phi \quad (21.3)$$

The total number of collisions per unit area and per unit time made by molecules with speed v is found by integrating over θ from zero to $\pi/2$, and over ϕ from zero to 2π . This gives:

$$\begin{aligned} \frac{1}{4\pi} v dn_v \int_0^{\pi/2} \sin \theta \cos \theta d\theta \int_0^{2\pi} d\phi &= \frac{1}{4\pi} v dn_v \frac{1}{2} 2\pi \\ &= \frac{1}{4} v dn_v \end{aligned} \quad (21.4)$$

The total number of collisions per unit area and per unit time made by molecules having all speeds is given by:

$$\frac{1}{4} \int_{v=0}^{v=\infty} v dn_v = \frac{1}{4} n \bar{v} \quad (21.5)$$

where \bar{v} is the arithmetic mean speed defined by:

$$\bar{v} = \frac{\int_0^{\infty} v dn_v}{\int_0^{\infty} dn_v} = \frac{\int_0^{\infty} v dn_v}{n} \quad (21.6)$$

Multiplying the numerator and denominator by volume V ,

Here,

$$\overline{v^2} = \frac{\sum N_i v_i^2}{\sum N_i} = \frac{N_1 v_1^2 + N_2 v_2^2 + \dots}{N_1 + N_2 + \dots} = \frac{\sum n_i v_i^2}{n}$$

21.5 Absolute Temperature of a Gas

Since $n = N/V$, Eq. (21.15) can be written as:

$$pV = \frac{1}{3} m N \overline{v^2} \quad (21.16)$$

For an ideal gas,

$$pV = n \bar{R} T,$$

where n = number of moles, \bar{R} = universal gas constant 8.3143 kJ/(kgmol-K) and T = absolute temperature. Now,

$$n = N/N_0,$$

where N_0 is the Avogadro's number, 6.023×10^{26} molecules/kgmol. Therefore, the ideal gas equation of state is:

$$pV = N \frac{\bar{R}}{N_0} T = NKT \quad (21.17)$$

where K = Boltzmann constant = 1.38×10^{-23} J/(molecule-K). From Eqs (21.16) and (21.17),

$$NKT = \frac{1}{3} m N \overline{v^2}$$

$$\overline{v^2} = \frac{3KT}{m} = (v_{\text{rms}})^2$$

or

$$v_{\text{rms}} = [3KT/m]^{1/2} \quad (21.18)$$

where v_{rms} is called the root-mean-square (rms) velocity of molecules, which is a function of temperature. Now,

$$\frac{1}{2} m \overline{v^2} = \frac{1}{2} m \frac{3KT}{m} = \frac{3}{2} KT \quad (21.19)$$

The mean translational K.E. of a molecule is proportional to the absolute temperature, or conversely, the absolute temperature of a gas is a measure of the K.E. of the molecules.

The total translational K.E. of the molecules, U , is

$$U = \frac{3}{2} NKT \quad (21.20)$$

The speed of a pressure pulse in an ideal gas is given by

$$v_s = [\gamma RT]^{1/2}$$

$$\text{or} \quad \left[p + \frac{a}{v^2} \right] [v - b] = \bar{R}T \quad (21.25)$$

where v is the molar volume (m^3/kgmol). This is known as the *van der Waals equation of state*.

21.9 Maxwell-Boltzmann Velocity Distribution

It was shown that the rms velocity of the molecules of a gas is related to the gas temperature. If all the molecules of a gas at a certain temperature move at the same speed, then the rms value describes the velocity magnitude of all the molecules. However, the speeds of gas molecules vary widely, and it is thus necessary to determine the velocity distribution of the molecules, so that the number of molecules moving with any particular velocity can be determined.

Let us consider a volume of gas at a constant temperature, the molecules of which are moving at different velocities. The instantaneous velocity vector of each molecule is resolved into components v_x , v_y and v_z . Let us imagine a velocity space (Fig. 21.7) so that the surface area of a sphere represents, at an instant of time, all molecules of equal velocities. Each molecule has a representative point in velocity space. The number of molecules whose velocities lie between v and

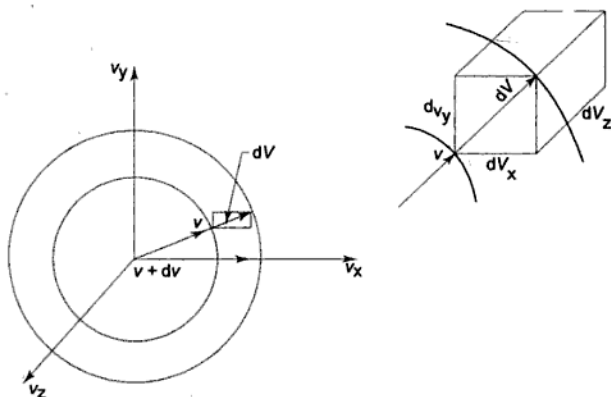

Fig. 21.7 Velocity space

$v + dv$ would be represented by the spherical strip of thickness dv , and be denoted by dN_v . Since the total number of molecules N is very large, the strip dv , although small, still contains a large number of molecules. Let dN_{v_x} represent the number of molecules whose x -component velocities lie between v_x and $v_x + dv_x$. Then the fraction $(dN_{v_x})/N$ is a function of the magnitude of v_x and the distance dv_x , or

$$\frac{dN_{v_x}}{N} = f(v_x) dv_x \quad (21.26)$$

where $f(v_x)$ is called the distribution function for x -component of velocity.

Similarly,

$$\frac{dN_{v_y}}{N} = f(v_y) dv_y \quad (21.27)$$

and
$$\frac{dN_{v_z}}{N} = f(v_z) dv_z \quad (21.28)$$

Some of the molecules of dN_{v_x} have y -component velocities lying between v_y and $v_y + dv_y$, and let this be represented by $d^2N_{v_x, v_y}$. A differential of second order $d^2N_{v_x, v_y}$ has been used, since this is a small fraction of an already small fraction, but still large enough to contain many molecules. Since the number of molecules is large, the following relation holds good.

$$\frac{d^2N_{v_x, v_y}}{dN_{v_x}} = \frac{dN_{v_y}}{N} \quad (21.29)$$

or
$$\begin{aligned} d^2N_{v_x, v_y} &= dN_{v_x} dN_{v_y} \cdot \frac{1}{N} \\ &= Nf(v_x)f(v_y) dv_x dv_y \end{aligned} \quad (21.30)$$

Similarly, $d^3N_{v_x, v_y, v_z}$ represent the number of molecules whose velocity components would lie between v_x and $v_x + dv_x$, v_y and $v_y + dv_y$ and v_z and $v_z + dv_z$. Therefore,

$$d^3N_{v_x, v_y, v_z} = Nf(v_x)f(v_y)f(v_z) dv_x dv_y dv_z \quad (21.31)$$

The number of representative points per unit volume, or the density of points in velocity space, represented by ρ , is:

$$\rho = \frac{d^3N_{v_x, v_y, v_z}}{dv_x dv_y dv_z} = Nf(v_x)f(v_y)f(v_z) \quad (21.32)$$

Since the velocity distribution is isotropic, the density is the same in any volume element so that:

$$\begin{aligned} d\rho &= Nf'(v_x)f(v_y)f(v_z) dv_x + Nf(v_x)f'(v_y)f(v_z) \\ &\quad dv_y + Nf(v_x)f(v_y)f'(v_z) dv_z = 0 \end{aligned}$$

or
$$\frac{f'(v_x)}{f(v_x)} dv_x + \frac{f'(v_y)}{f(v_y)} dv_y + \frac{f'(v_z)}{f(v_z)} dv_z = 0 \quad (21.33)$$

At a radial distance v from the origin,

$$\begin{aligned} v^2 &= v_x^2 + v_y^2 + v_z^2 = \text{constant} \\ v_x dv_x + v_y dv_y + v_z dv_z &= 0 \end{aligned} \quad (21.34)$$

To solve the Eq. (21.33) subject to the constraint of the equation (21.34), *Lagrange's method of undetermined multipliers* is applied. Multiplying Eq. (21.34) by λ and adding to Eq. (21.33),

$$\left[\frac{f'(v_x)}{f(v_x)} + \lambda v_x \right] dv_x + \left[\frac{f'(v_y)}{f(v_y)} + \lambda v_y \right] dv_y + \left[\frac{f'(v_z)}{f(v_z)} + \lambda v_z \right] dv_z = 0 \quad (21.35)$$

where λ is called the *Lagrange's multiplier*.

Since v_x , v_y and v_z are now independent variables, the coefficients of dv_x , dv_y and dv_z are individually equated to zero.

$$\frac{f'(v_x)}{f(v_x)} + \lambda v_x = 0 \quad (21.36)$$

$$\frac{f'(v_y)}{f(v_y)} + \lambda v_y = 0 \quad (21.37)$$

$$\frac{f'(v_z)}{f(v_z)} + \lambda v_z = 0 \quad (21.38)$$

From Eq. (21.36),

$$\frac{df(v_x)}{dv_x} \frac{1}{f(v_x)} + \lambda v_x = 0$$

$$\frac{df(v_x)}{f(v_x)} = -\lambda v_x dv_x$$

$$\ln f(v_x) = -\lambda \frac{v_x^2}{2} + \ln \alpha$$

$$\text{or} \quad f(v_x) = \alpha \cdot e^{-(\lambda v_x^2)/2} \quad (21.39)$$

$$\text{Similarly,} \quad f(v_y) = \alpha \cdot e^{-(\lambda v_y^2)/2} \quad (21.40)$$

$$\text{and} \quad f(v_z) = \alpha \cdot e^{-(\lambda v_z^2)/2} \quad (21.41)$$

where α is the constant of integration. The symmetry provides the same integration constant for all the three equations.

Substituting the expressions for $f(v_x)$, $f(v_y)$ and $f(v_z)$ in Eq. (21.32),

$$\rho = N \alpha^3 e^{-\lambda/2} [v_x^2 + v_y^2 + v_z^2] = \frac{d^3 N_{v_x, v_y, v_z}}{dv_x dv_y dv_z}$$

$$\text{or} \quad \rho = N \alpha^3 e^{-\beta^2 v^2} \quad (21.42)$$

where

$$\beta^2 = \lambda/2$$

The density is found to be a function of v only, and it is maximum at the origin where $v = 0$ and falls off exponentially with v^2 (Fig. 21.8). To calculate the number of molecules with speeds between v and $v + dv$, the volume of the spherical shell of thickness dv at a distance v from the origin is multiplied by the density of points, so that

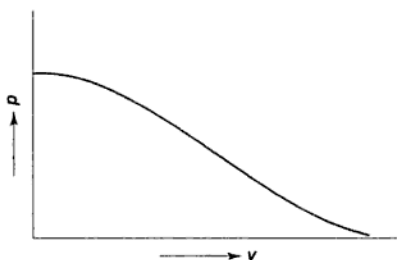

Fig. 21.8 Density of velocity points

$$dN_v = 4 \pi v^2 dv \rho \quad (21.43)$$

Substituting for ρ from Eq. (21.42), the total number of molecules:

$$\begin{aligned} N &= \int_0^{\infty} 4 \pi v^2 N \alpha^3 e^{-\beta^2 v^2} dv \\ &= 4 \pi N \alpha^3 \int_0^{\infty} v^2 e^{-\beta^2 v^2} dv \end{aligned} \quad (21.44)$$

To integrate the above expression, let $x = \beta^2 v^2$, so that

$$dx = \beta^2 2 \frac{\sqrt{x}}{\beta} dv = 2\beta \sqrt{x} dv.$$

$$\begin{aligned} \int_0^{\infty} v^2 e^{-\beta^2 v^2} dv &= \int_0^{\infty} \frac{x}{\beta^2} e^{-x} \frac{dx}{2\beta \sqrt{x}} \\ &= \frac{1}{2\beta^3} \int_0^{\infty} x^{(3/2)-1} e^{-x} dx \\ &= \frac{1}{2\beta^3} \Gamma\left(\frac{3}{2}\right) = \frac{1}{2\beta^3} \frac{\sqrt{\pi}}{2} \end{aligned}$$

where $\Gamma(n) = \int_0^{\infty} x^{n-1} e^{-x} dx$ ($n > 0$) is called *gamma function*, the values of which are given in Table 21.1.

Now,
$$U = \frac{3}{2} NKT = \frac{3mN}{4\beta^2}$$

$\therefore \beta = \left[\frac{m}{2KT} \right]^{1/2}$ (21.47)

From Eq. (21.45)

$$\alpha = \left[\frac{m}{2\pi KT} \right]^{1/2}$$
 (21.48)

Substituting these values in Eq. (21.43),

$$\begin{aligned} dN_v &= 4\pi v^2 dv N \alpha^3 e^{-\beta^2 v^2} \\ &= 4\pi N \left[\frac{m}{2\pi KT} \right]^{3/2} v^2 e^{-(m/2KT)v^2} dv \end{aligned}$$

or
$$\frac{dN_v}{dv} = \frac{4N}{\sqrt{\pi}} \left[\frac{m}{2KT} \right]^{3/2} v^2 e^{-\frac{m}{2KT}v^2}$$
 (21.49)

This equation is known as *Maxwell-Boltzmann velocity distribution function*. Plots of dN_v/dv vs. v are shown in Fig. 21.9 at three different temperatures. The areas under all these three curves are the same, since the area represents the total number of molecules. The area of the elemental strip of thickness dv at a distance v from the origin under the curve, say, at temperature T_1 represents the number of molecules dN_v having velocities lying between v and $v + dv$, which on integration from $v = 0$ to $v = \infty$ becomes N , the total number of molecules. It can be shown that the maxima of these curves (Fig. 21.9) fall on an equilateral hyperbola (see Ex. 21.5).

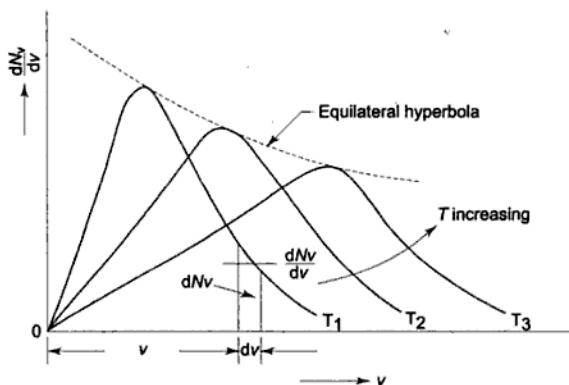

Fig. 21.9 Velocity distribution function at three different temperature, $T_3 > T_2 > T_1$

Substituting α and β in Eq. (21.42) for ρ ,

$$d^3N_{v_x, v_y, v_z} = N \left[\frac{m}{2\pi KT} \right]^{3/2} e^{-\frac{mv^2}{2KT}} dv_x dv_y dv_z \quad (21.50)$$

The speed distribution function for each of the three velocity components may similarly be determined. From Eqs (21.26) and (21.39),

$$\begin{aligned} dN_{v_x} &= N f(v_x) dv_x = N \alpha e^{-(\lambda v_x^2)/2} dv_x \\ &= N \left(\frac{m}{2\pi KT} \right)^{1/2} e^{-\frac{m}{2KT} v_x^2} dv_x \\ \frac{dN_{v_x}}{dv_x} &= \frac{N}{\sqrt{\pi}} \left(\frac{m}{2KT} \right)^{1/2} e^{-\frac{m}{2KT} v_x^2} \end{aligned} \quad (21.51)$$

A plot of dN_{v_x}/dv_x vs. v_x at a certain temperature is represented in Fig. 21.10.

The curve is symmetric about $v_x = 0$ and has a maximum value of $N \left[\frac{m}{2\pi KT} \right]^{1/2}$.

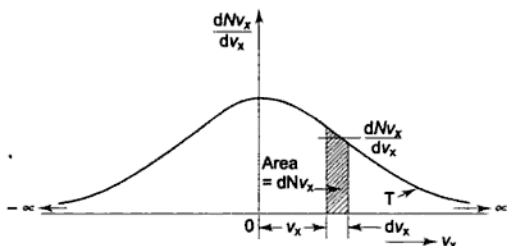

Fig. 21.10 Maxwell-Boltzmann distribution function for x -component velocity

21.10 Average, Root-Mean-Square and Most Probable Speeds

The average speed, \bar{v} , of a gas molecule is defined as the sum of the speeds of all molecules divided by the number of molecules.

$$\begin{aligned} \bar{v} &= \frac{\int_0^{\infty} v dN_v}{\int_0^{\infty} dN_v} = \frac{1}{N} \int_0^{\infty} v 4\pi v^2 dv N \alpha^3 e^{-\beta^2 v^2} \\ &= \frac{4\beta^3}{\sqrt{\pi}} \int_0^{\infty} v^2 e^{-\beta^2 v^2} dv \end{aligned}$$

$$\text{Let } x = \beta^2 v^2, \text{ then } v dv = \frac{1}{2\beta^2} dx$$

and

$$\begin{aligned} \bar{v} &= \frac{4\beta^3}{\sqrt{\pi}} \int_0^{\infty} \frac{x}{\beta^2} \frac{1}{2\beta^2} dx e^{-x} \\ &= \frac{2}{\beta\sqrt{\pi}} \int_0^{\infty} x^{2-1} e^{-x} dx = \frac{2}{\beta\sqrt{\pi}} \Gamma(2) \\ &= \frac{2}{\beta\sqrt{\pi}} \end{aligned}$$

$$\bar{v} = \frac{2}{\sqrt{\pi}} \left[\frac{2KT}{m} \right]^{1/2}$$

or

$$\bar{v} = \left[\frac{8KT}{\pi m} \right]^{1/2} \quad (21.52)$$

The root-mean-square speed is defined as the sum of the squares of the velocities of all molecules divided by the number of molecules.

$$\begin{aligned} v_{\text{rms}}^2 &= \frac{\int_0^{\infty} v^2 dN_v}{\int_0^{\infty} dN_v} = \frac{1}{4} \int_0^{\infty} v^2 4\pi v^2 N \frac{\beta^3}{\pi^{3/2}} e^{-\beta^2 v^2} dv \\ &= \frac{4\beta^3}{\sqrt{\pi}} \int_0^{\infty} v^4 e^{-\beta^2 v^2} dv \end{aligned}$$

Putting

$$x = \beta^2 v^2,$$

$$\begin{aligned} v_{\text{rms}}^2 &= \frac{4\beta^3}{\sqrt{\pi}} \int_0^{\infty} \frac{\sqrt{x}}{\beta} \frac{x}{\beta^2} \frac{1}{2\beta^2} dx e^{-x} \\ &= \frac{4\beta^3}{\sqrt{\pi}} \frac{1}{2\beta^5} \int_0^{\infty} x^{(5/2)-1} e^{-x} dx \\ &= \frac{2}{\beta^2 \sqrt{\pi}} \Gamma\left(\frac{5}{2}\right) = \frac{2}{\beta^2 \sqrt{\pi}} \frac{3}{4} \sqrt{\pi} = \frac{3}{2\beta^2} \end{aligned}$$

$$v_{\text{rms}} = \sqrt{\frac{3}{2}} \frac{1}{\beta}$$

or

$$v_{\text{rms}} = \left[\frac{3KT}{m} \right]^{1/2} \quad (21.53)$$

The most probable speed is the speed at which the largest number of molecules is moving. It is the speed which occurs most frequently. To determine v_{mp} , the

expression of dN_v/dv , is differentiated with respect to v and equated to zero. From equation (21.49), using β ,

$$\frac{d}{dv} \left(\frac{dN_v}{dv} \right) = \frac{d}{dv} \left[\frac{4N}{\sqrt{\pi}} \beta^3 v^2 e^{-\beta^2 v^2} \right] = 0$$

or
$$\frac{4N}{\sqrt{\pi}} \beta^3 [e^{-\beta^2 v^2} 2v + v^2 (-\beta^2 2v) e^{-\beta^2 v^2}] = 0$$

$$v_{mp} = 1/\beta$$

or
$$v_{mp} = [2KT/m]^{1/2} \quad (21.54)$$

The relative magnitudes of the three speeds are shown in Fig. 21.11 and their values are in the following proportions:

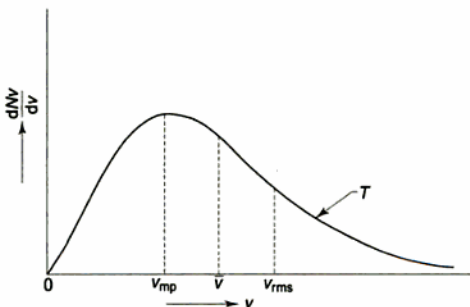

Fig. 21.11 Relative magnitudes of v_{mp} , \bar{v} and v_{rms} .

$$v_{mp} : \bar{v} : v_{rms} = 1 : 1.128 : 1.224 \quad (21.55)$$

21.11 Molecules in a Certain Speed Range

To calculate the number of molecules with speeds in a certain range, it is necessary to integrate the speed distribution function between the limits of that range (Fig. 21.12). The number of molecules having speeds between 0 and v is given by:

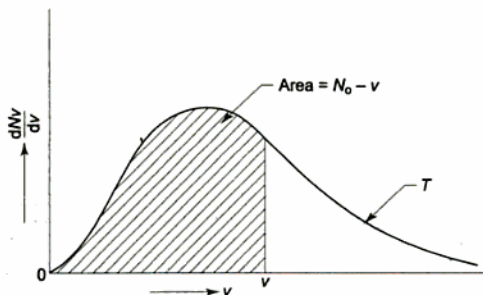

Fig. 21.12 Number of molecules in the speed range of 0 and v

$$N_{0-v} = \int_0^v dN_v = \frac{4N}{\sqrt{\pi}} \int_0^v \beta^3 v^2 e^{-\beta^2 v^2} dv$$

Let

$x = \beta v = v/v_{mp}$ and $dx = \beta dv$, then on substitution,

$$\begin{aligned} N_{0-v} &= \frac{4N}{\sqrt{\pi}} \int_0^x x^2 e^{-x^2} dx \\ &= -\frac{2N}{\sqrt{\pi}} \int_0^x x d(e^{-x^2}) \end{aligned}$$

Integrating by parts,

$$\begin{aligned} N_{0-v} &= -\frac{2N}{\sqrt{\pi}} \left[x e^{-x^2} - \int_0^x e^{-x^2} dx \right] \\ &= N \left[\frac{2}{\sqrt{\pi}} \int_0^x e^{-x^2} dx - \frac{2}{\sqrt{\pi}} x e^{-x^2} \right] \\ &= N \left[\operatorname{erf}(x) - \frac{2}{\sqrt{\pi}} x e^{-x^2} \right] \end{aligned} \quad (21.56)$$

where $x = \left[\frac{m}{2KT} \right]^{1/2} v$ and $\operatorname{erf}(x)$ is the *error function* defined as:

$$\operatorname{erf}(x) = \frac{2}{\sqrt{\pi}} \int_0^x e^{-x^2} dx$$

The values of $\operatorname{erf}(x)$ as a function of x are given in Table 21.2.

Table 21.2 Values of the Error Function

$$\operatorname{erf}(x) = \frac{2}{\sqrt{\pi}} \int_0^x e^{-x^2} dx$$

x	$\operatorname{erf}(x)$	x	$\operatorname{erf}(x)$	x	$\operatorname{erf}(x)$
0	0	1.0	0.8427	2.0	0.9953
0.2	0.2227	1.2	0.9103	2.2	0.9981
0.4	0.4284	1.4	0.9523	2.4	0.9993
0.6	0.6039	1.6	0.9763	2.6	0.9998
0.8	0.7421	1.8	0.9891	2.8	0.9999

To compute the number of molecules having velocities lying between 0 and v_{mp} , the value of x will lie between 0 and 1. Then, from Eq. (21.56),

$$\begin{aligned} N_{0-v_{mp}} &= N \left[\operatorname{erf}(1) - \frac{2}{\sqrt{\pi}} 1 e^{-1} \right] \\ &= N \left[0.8427 - \frac{2}{\sqrt{\pi} \times 2.718} \right] \end{aligned}$$

$$= 0.4167 N$$

i.e. 41.67 per cent of the molecules have speeds between 0 and v_{mp} .

Similarly, to find the number of molecules having x -components of velocity between 0 and v_x ,

$$N_{0-v_x} = \int_0^{v_x} dN_{v_x}$$

From Eq. (21.51),

$$dN_{v_x} = N \frac{\beta}{\sqrt{\pi}} e^{-\beta^2 v_x^2} dv_x$$

Putting

$$x = \beta v_x = v_x/v_{mp}, \text{ where } dx = \beta dv_x$$

$$dN = \frac{N}{\sqrt{\pi}} e^{-x^2} dx$$

$$N_{0-x} = \frac{N}{\sqrt{\pi}} \int_0^x e^{-x^2} dx \quad (21.57)$$

Now,
$$\int_0^x e^{-x^2} dx = \frac{\sqrt{\pi}}{2} \operatorname{erf}(x),$$

so,
$$N_{0-x} = \frac{N}{2} \operatorname{erf}(x) \quad (21.58)$$

For

$$x = 1,$$

$$N_{0-1} = \frac{N}{2} \times 0.8427 = 0.4214 N$$

For

$$x = \infty,$$

$$N_{0-\infty} = N/2$$

The number of molecules having x -component velocities between x and ∞ ,

$$\begin{aligned} N_{x-\infty} &= \frac{N}{2} - \frac{N}{2} \operatorname{erf}(x) \\ &= \frac{N}{2} [1 - \operatorname{erf}(x)] \end{aligned} \quad (21.59)$$

21.12 Energy Distribution Function

The molecules of a gas at a certain temperature have different velocities and hence different kinetic energies. The translational kinetic energy ϵ of a molecule of mass m moving with a velocity v , is

$$\epsilon = \frac{1}{2} mv^2$$

Differentiating,

$$d\varepsilon = m v dv = m \sqrt{\frac{2\varepsilon}{m}} dv = \sqrt{2m\varepsilon} dv$$

An expression for the number of molecules with translational kinetic energies within a certain range, say between ε and $\varepsilon + d\varepsilon$ will now be derived. From Eq. (21.49),

$$dN_\varepsilon = \frac{4}{\sqrt{\pi}} \left(\frac{m}{2KT} \right)^{3/2} \frac{2\varepsilon}{m} e^{-\varepsilon/KT} \frac{d\varepsilon}{(2m\varepsilon)^{1/2}}$$

Therefore,

$$\frac{dN_\varepsilon}{d\varepsilon} = \frac{2N}{\sqrt{\pi}} \frac{\varepsilon^{1/2}}{(KT)^{3/2}} e^{-\varepsilon/KT} \quad (21.60)$$

The notation of dN_v has been changed to dN_ε , since the distribution is now expressed in terms of ε . The above equation is known as the *Maxwell-Boltzmann energy distribution function* where dN_ε represents the number of molecules having energy between ε and $\varepsilon + d\varepsilon$. Figure 21.13 shows the distribution of energy of molecules. The most probable energy of the molecules is given by making:

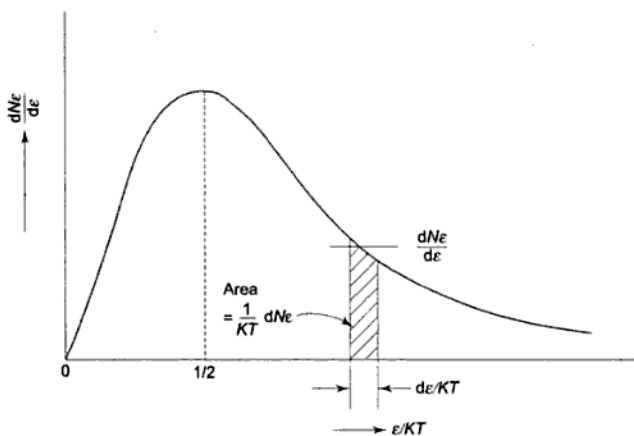

Fig. 21.13 Maxwell-Boltzmann energy distribution function

$$\begin{aligned} \frac{d}{d\varepsilon} \left[\frac{dN_\varepsilon}{d\varepsilon} \right] &= \frac{2N}{\sqrt{\pi}} \frac{1}{(KT)^{3/2}} \left[e^{-\varepsilon/KT} \frac{1}{2} \varepsilon^{-1/2} \right. \\ &\quad \left. + \varepsilon^{1/2} \left(-\frac{1}{KT} \right) e^{-\varepsilon/KT} \right] = 0 \end{aligned}$$

On Simplification,

$$\varepsilon_{mp} = \frac{1}{2} KT \quad (21.61)$$

Chapter 19. The kinetic energy associated with v_x is a quadratic function of v_x , and the mean value of ϵ_x , as found earlier, is $\frac{1}{2} KT$. For rotation, the kinetic energy is $\frac{1}{2} I\omega^2$ and the mean rotational kinetic energy associated per degree of freedom is $\frac{1}{2} KT$. Similarly, for a simple harmonic oscillator, the potential energy is $\frac{1}{2} kx^2$, where k is the force constant, and the mean potential energy is $\frac{1}{2} KT$. Therefore, for all the degrees of freedom in which energy is a quadratic function, equal amounts of energy are associated, and the total energy of a molecule is shared equally among all the degrees of freedom. This underlies the *principle of equipartition of energy*.

21.14 Specific Heat of a Gas

Following the equipartition principle, the mean total energy of a molecule having f degrees of freedom is:

$$\bar{\epsilon} = \frac{f}{2} KT \quad (21.62)$$

and the total energy of N molecules is:

$$U = N\bar{\epsilon} = \frac{f}{2} NKT = \frac{f}{2} n\bar{R}T$$

or, molal internal energy, $u = \frac{f}{2} \bar{R}T$

and molal specific heat at constant volume:

$$c_v = \left[\frac{\partial u}{\partial T} \right]_v = \frac{f}{2} \bar{R} \quad (21.63)$$

For an ideal gas,

$$c_p - c_v = \bar{R}$$

$$c_p = \frac{f}{2} \bar{R} + \bar{R} = \frac{f+2}{2} \bar{R}$$

and $\gamma = c_p/c_v = \frac{f+2}{f} \quad (21.64)$

It is to be noted that c_v , c_p and γ are all constants and independent of temperature.

For a monatomic gas which has only translational kinetic energy, $f=3$. Thus,

$$u = \frac{3}{2} \bar{R}T, \quad c_v = \frac{3}{2} \bar{R}, \quad c_p = \frac{5}{2} \bar{R} \quad \text{and} \quad \gamma = \frac{5}{3} = 1.67.$$

Petit treated a solid as consisting of atoms, each regarded as a harmonic oscillator of three degrees of freedom. For simple harmonic motion, the energy associated is partly kinetic and partly potential. If the equipartition principle holds good for solids, $\frac{1}{2} KT$ is assigned for kinetic energy and $\frac{1}{2} KT$ for potential energy, so that for each degree of freedom the energy associated is KT , and for three degrees of freedom it is $3KT$. So the total energy of N molecules is:

$$U = 3 NKT = 3 n \bar{R} T$$

or
$$u = 3 \bar{R} T$$

and the molar specific heat at constant volume is:

$$c_v = 3 \bar{R} = 24.9 \text{ kJ/kgmol K} \quad (21.65)$$

This is known as the *Dulong-Petit law* which states that the molar specific heats, at constant volume, of all pure substances in the solid state, at temperatures, which are not too low, are nearly equal to $3 \bar{R}$. This agrees well with practical values. But as $T \rightarrow 0 \text{ K}$, $c_v \rightarrow 0$. So the classical theory of specific heat of a solid fails at very low temperatures, and the solution requires the methods of quantum mechanics as proposed first by Einstein and then improved by Debye (Chapter 19). Figure 21.15 gives the variation of $c_v/3\bar{R}$ with θ_E/T , where θ_E is the Einstein temperature $h\nu/K$. It shows that as $T \rightarrow 0$, $c_v \rightarrow 0$ and as $T \rightarrow \infty$, $c_v \rightarrow 3 \bar{R}$.

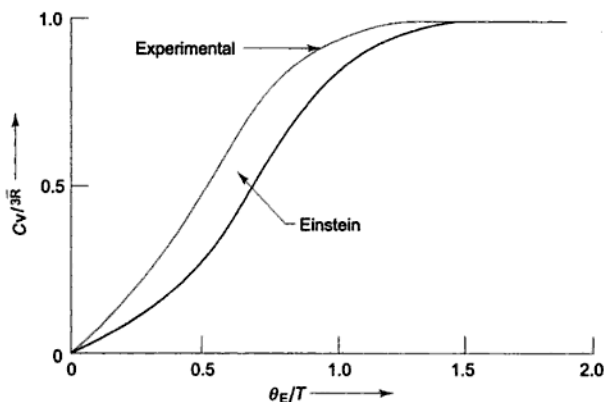

Fig. 21.15 Specific heat of solids

SOLVED EXAMPLES

Example 21.1 Calculate the rms speed for oxygen at 300K. What is the mean translational kinetic energy of a molecule of oxygen?

$$\int_{x=N}^x \frac{dx}{2 \cdot x} = \int_{t=0}^t -\frac{A\bar{v}}{4V} dt$$

$$\ln \frac{2N_1 - N}{N} = -\frac{A\bar{v}}{2V} t$$

$$\frac{2N_1 - N}{N} = \exp\left(-\frac{A\bar{v}t}{2V}\right)$$

$$\frac{2N_1}{N} = 1 + \exp\left(-\frac{A\bar{v}t}{2V}\right)$$

$$N_1 = \frac{N}{2} \left[1 + \exp\left(-\frac{A\bar{v}t}{2V}\right)\right]$$

Since, $pV = NKT$,

$$N_1 = \frac{p_1 V}{KT}, \text{ where } p_1 \text{ is the pressure of gas in the left chamber, and } N = P_0 V / KT$$

where p_0 is the initial pressure. On substitution,

$$p_1 = \frac{P_0}{2} \left[1 + \exp\left(-\frac{A\bar{v}t}{2V}\right)\right] \quad (1)$$

Similarly, on the right side of the membrane,

$$dN_2 = +\frac{A\bar{v}}{4} \left[\frac{N_1}{V} - \frac{N_2}{V}\right] dt$$

$$= \frac{A\bar{v}}{4V} [N - N_2 - N_2] dt$$

$$= \frac{A\bar{v}}{4V} [N - 2N_2] dt$$

$$\frac{dN_2}{N - 2N_2} = \frac{A\bar{v}}{4V} dt$$

Let $x = N - 2N_2$, so that $dx = -2dN_2$.

Initially, $N_2 = 0$ (evacuated), $\therefore x = N$

$$\int_{x=N}^{x=N-2N_2} -\frac{dx}{2x} = \int_{t=0}^t \frac{A\bar{v}}{4V} dt$$

$$\ln \frac{N - 2N_2}{N} = -\frac{A\bar{v}t}{2V}$$

$$1 - \frac{2N_2}{N} = \exp\left[-\frac{A\bar{v}t}{2V}\right]$$

$$N_2 = \frac{N}{2} \left[1 - \exp\left(-\frac{A\bar{v}t}{2V}\right)\right]$$

or
$$p_r = \frac{p_0}{2} \left[1 - \exp\left(-\frac{A\bar{v}t}{2V}\right) \right] \quad (2)$$

Equations (1) and (2) show the variations of pressure with time in the left and right chambers.

At $t = 0$, $p_1 = p_0$ and $p_r = 0$. At $t = \infty$, $p_1 = p_r = p_{0/2}$ Ans.

Example 21.4 A spherical satellite is moving in the outer fringes of the earth's atmosphere where the molecular free paths are very much large compared to the satellite radius r . By treating the satellite as moving with velocity u through a space with particle density n of stationary molecules of mass m , derive an expression for the drag due to elastic collisions with these molecules of the rarefied gas.

Solution It is the case of collision (elastic) of a molecule with a moving wall and it will be assumed that the relative velocity of the molecule before and after collision remains unchanged (Article 21.7). The loss of kinetic energy in one collision is:

$$\frac{1}{2} m (v \cos \theta)^2 - \frac{1}{2} m (v \cos \theta - 2u)^2 = 2 m v u \cos \theta - 2mu^2$$

Loss of K.E. in all collisions per unit area per unit time

$$\begin{aligned} &= \iiint_{\phi, \theta, v} \left[\frac{1}{4\pi} v dn_v \sin \theta \cos \theta d\theta d\phi \right] [2 m v u \cos \theta - 2mu^2] \\ &= \frac{1}{2\pi} m u \left[\int_0^\infty v^2 dn_v \int_0^{\pi/2} \sin \theta \cos^2 \theta d\theta \int_0^{2\pi} d\phi \right. \\ &\quad \left. - u \int_0^\infty v dn_v \int_0^{\pi/2} \sin \theta \cos \theta d\theta \int_0^{2\pi} d\phi \right] \\ &= \frac{1}{2\pi} m n \bar{v}^2 \left[\frac{1}{3} 2\pi - \frac{1}{2\pi} m u^2 \bar{v} n \frac{1}{2} 2\pi \right] \\ &= \frac{1}{3} m n \bar{v}^2 u - \frac{1}{2} m n \bar{v} u^2 \end{aligned}$$

The drag on the spherical satellite due to collisions of molecules:

$$\begin{aligned} &= \frac{\left[\frac{1}{3} m n \bar{v}^2 u - \frac{1}{2} m n \bar{v} u^2 \right] 4\pi r^2}{u} \\ &= 2\pi m n r^2 \left[\frac{2}{3} \bar{v}^2 - u \bar{v} \right] \quad \text{Ans.} \end{aligned}$$

Example 21.5 A thin-walled vessel of volume V maintained at constant temperature contains a gas which leaks out slowly through a small hole of area

A. The pressure outside is low enough so that back leakage into the vessel is negligible. Find the time required for the pressure in the vessel to decrease to $1/e$ of its original value, expressed in terms of A , V and \bar{v} .

Solution Rate of molecular collisions per unit area are $a = \frac{1}{4} n \bar{v}$. Neglecting back leakage of gas into the vessel from outside, the net rate of flow of gas molecules through the hole of area A is given by:

$$\frac{dN}{dt} = \frac{1}{4} n \bar{v} A = -\frac{1}{4} \frac{N}{V} \bar{v} A$$

$$\int_{N_0}^{N_f} \frac{dN}{N} = - \int_{t=0}^t \frac{1}{4} \frac{A \bar{v}}{V} dt$$

where N_0 and N_f are the initial and final number of molecules of gas in the vessel and t is the time.

$$\ln \frac{N_f}{N_0} = - \frac{1}{4} \frac{A \bar{v} t}{V}$$

Again, $pV = NKT$, assuming the gas to be ideal. Since V , K and T are constant,

$$p_f p_0 = N_f / N_0$$

Therefore,

$$p_f / p_0 = e^{-\frac{1}{4} \frac{A \bar{v} t}{V}} = \frac{1}{e} = e^{-1}$$

$$\frac{1}{4} \frac{A \bar{v} t}{V} = 1, \therefore \text{Time required, } t = \frac{4V}{A \bar{v}} \quad \text{Ans.}$$

Example 21.6 Taking the speed distribution law,

$$dN_v = 4 \pi N \left[\frac{m}{2 \pi K T} \right]^{3/2} e^{-(mv^2)/(2KT)} v^2 dv$$

and setting $y = dN_v/dv$, show that the maxima of the curves for different temperatures fall on an equilateral hyperbola given by

$$y \cdot v_{mp} = \frac{4N}{e\sqrt{\pi}},$$

where v_{mp} is the most probable velocity.

Solution

$$\frac{dN_v}{dv} = y = 4 \pi N \left[\frac{m}{2 \pi K T} \right]^{3/2} e^{-(mv^2)/(2KT)} v^2$$

For y to be maximum, $dy/dv = 0$ when

$$v = v_{max} = v_{mp}$$

The most probable velocity $v_{mp} = [2KT/m]^{1/2}$

Substituting v_{mp} for v and for $[2KT/m]^{1/2}$,

$$y = 4 \pi N [1/v_{mp}]^3 \frac{1}{\pi^{3/2}} e^{-(v_{mp}^2)/(v_{mp}^2)} v_{mp}^2$$

or

$$y = \frac{4N}{\sqrt{\pi}} \frac{1}{v_{mp}} \frac{1}{e}$$

$$y \cdot v_{mp} = \frac{4N}{e\sqrt{\pi}}$$

Therefore, the maxima of the isotherms fall on an equilateral hyperbola given by the above equation (see Fig. 21.9).

Example 21.7 Compute the most probable speed, the mean speed, and the root-mean-square speed for helium at 0°C .

Solution Mass of an helium atom = $\frac{4.008}{6.023 \times 10^{23}} = 6.65 \times 10^{-24}$ g

$$v_{mp} = [2KT/m]^{1/2} = \left[\frac{2 \times 1.38 \times 10^{-16} \times 273.15}{6.65 \times 10^{-24}} \right]^{1/2}$$

$$= 1064 \text{ m/s} \quad \text{Ans.}$$

$$\bar{v} = [8KT/\pi m]^{1/2} = \left[\frac{8 \times 1.38 \times 10^{-16} \times 273.15}{3.14 \times 6.65 \times 10^{-24}} \right]^{1/2}$$

$$= 1201 \text{ m/s.} \quad \text{Ans.}$$

$$v_{rms} = [3KT/m]^{1/2} = 1303 \text{ m/s.} \quad \text{Ans.}$$

Example 21.8 Calculate the collision rate of oxygen molecules on the wall per unit area at 1 atm and 0°C .

Solution

$$m_{O_2} = \frac{32}{6.023 \times 10^{23}} = 5.31 \times 10^{-23} \text{ g/molecule}$$

$$\bar{v} = [8KT/\pi m]^{1/2}$$

Rate of molecular collision

$$= \frac{1}{4} n \bar{v} = \frac{1}{4} \frac{p}{KT} \left[\frac{8KT}{\pi m} \right]^{1/2} = \frac{p}{[2\pi m KT]^{1/2}}$$

$$= \frac{1.01325 \times 10^5}{[2\pi \times 5.31 \times 10^{-26} \times 1.38 \times 10^{-23} \times 273.15]^{1/2}}$$

$$= 2.845 \times 10^{27} \text{ collisions/m}^2\text{s.} \quad \text{Ans.}$$

Transport Processes in Gases

Collisions between molecules were not considered in Chapter 21 while deriving the expressions for pressure and temperature of an ideal gas in terms of its molecular properties. Intermolecular collisions will now be considered.

22.1 Mean Free Path and Collision Cross-section

Let us single out one particular molecule represented by the black circle and trace its path among the other molecules, which would be assumed to be frozen in their respective positions (Fig. 22.1). The distance traversed by a molecule between successive collisions is called the free path, denoted by x , and the average length of these paths is called the *mean free path*, denoted by λ . The molecules are assumed to be perfectly elastic spheres of radius r . As two molecules collide, the centre-to-centre distance is $2r$, which would remain the same if the radius of the moving molecule is increased to $2r$ and the stationary molecules are shrunk to geometrical points, as shown in Fig. 22.1 The cross-sectional area of the moving molecule is called the *collision cross-section* σ , and it is given by

$$\sigma = 4\pi r^2$$

The moving molecule sweeps out in time t , a cylindrical volume of cross-sectional area σ and length $\bar{v}t$, where \bar{v} is the average velocity of the molecule. The number of collisions it makes during this time, will be the same as the number of molecules whose centres lie within this volume, which is $\sigma n \bar{v}t$, where n is the number of molecules per unit volume. The number of collisions per unit time is known as the *collision frequency*, denoted by z , which is:

$$z = \sigma n \bar{v} \quad (22.1)$$

The mean free path of the molecules is given by:

$$\lambda = \frac{\text{Distance travelled in time } t}{\text{Number of collisions in time } t}$$

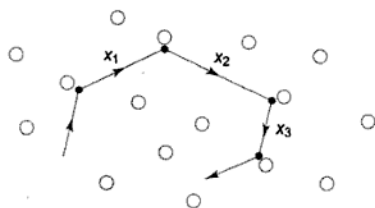

Fig. 22.1 Free paths of a gas molecule

$$= \frac{\bar{v} t}{\sigma n \bar{v} t} = \frac{1}{\sigma n} \quad (22.2)$$

On an average, the diameter (d) of the molecules is $(2 \text{ to } 3) \times 10^{-10} \text{ m}$, the distance between molecules $3 \times 10^{-9} \text{ m}$ (or $10d$), and the mean free path is about $3 \times 10^{-8} \text{ m}$ (or $100d$)

If motion of all the molecules is considered and all the molecules move with the same speed, a correction is required and λ is obtained as:

$$\lambda = 0.75/\sigma n \quad (22.3)$$

If the Maxwellian velocity distribution is assumed for the molecules,

$$\lambda = 0.707/\sigma n \quad (22.4)$$

For an electron moving among molecules of a gas, the radius of the electron is so small compared to that of a molecule that in a collision the electron may be treated as a point and the centre-to-centre distance becomes r , instead of $2r$, where r is radius of the molecule. Also, the velocity of the electron is so much greater than the velocities of the molecules that the latter can be considered stationary. As a result, no correction is required, and the electronic mean free path λ_e is given by:

$$\lambda_e = 4/\sigma n \quad (22.5)$$

where

$$\sigma = 4\pi r^2$$

22.2 Distribution of Free Paths

The distance travelled by a molecule between successive collisions or the free path x varies widely. It may be greater or less than λ , or equal to it. Just like distribution of molecular velocities, we will now determine how many molecules will have free paths in a certain range, say between x and $x + dx$.

Let us consider a large number of molecules N_0 at a certain instant (Fig. 22.2). If the molecules collide, they will be assumed to get removed from the group. Let N represent the number of molecules left in the group after travelling a distance x . Then these N molecules have free paths larger than x . In the next short distance dx , let dN number of molecules make collisions and get removed from the group. So, these dN molecules which have free paths lying between x and $x + dx$ are

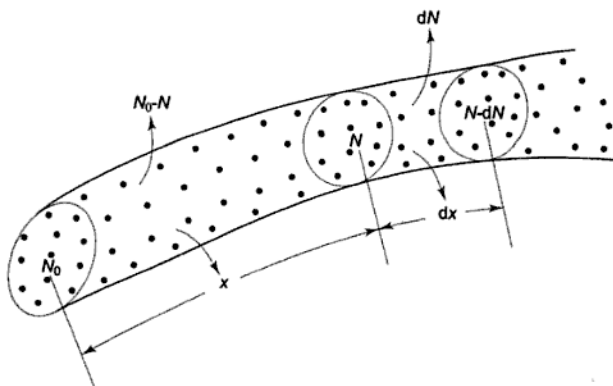

Fig. 22.2 Molecules colliding and getting removed from the group

proportional to N and to dx . Since N is always decreasing, dN is negative and it is given by:

$$dN = -P_c N dx \quad (22.6)$$

where P_c is the constant of proportionality, known as the *collision probability*. Then

$$\begin{aligned} dN/N &= -P_c dx \\ \ln N &= -P_c x + A \end{aligned}$$

where A is a constant. When $x = 0$, $N = N_0$, and so $A = \ln N_0$. Therefore,

$$N = N_0 e^{-P_c x} \quad (22.7)$$

The number of molecules that remains in the group falls off exponentially with x . From Eq. (22.6),

$$dN = -P_c N_0 e^{-P_c x} dx \quad (22.8)$$

Using this expression for dN , the mean free path λ becomes

$$\lambda = \frac{\int x dN}{\int dN} = \frac{\int_0^{\infty} -x P_c N_0 e^{-P_c x} dx}{N_0} = \frac{1}{P_c}$$

Since $\lambda = 1/\sigma n$, $P_c = \sigma n$. The collision probability is thus proportional to the collision cross-section and the number of molecules per unit volume. The Eq. (22.7) can thus be written as

$$N = N_0 e^{-x/\lambda} \quad (22.9)$$

It is known as the *survival equation* which indicates the number of molecules N , out of N_0 , which survive collision and have free paths longer than x . A plot of N/N_0 vs x/λ is shown in Fig. 22.3. If $x/\lambda = 1$, i.e., $x = \lambda$, $N/N_0 = 0.37$. The fraction

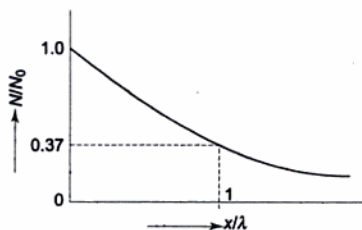

Fig. 22.3 Plot of survival equation

of free paths longer than λ is, therefore, 37% and the fraction shorter than λ is 63%.

Differentiating Eq. (22.9)

$$dN = \frac{N_0}{\lambda} e^{-x/\lambda} dx$$

or,
$$\frac{dN}{dx} = -\frac{N_0}{\lambda} e^{-x/\lambda} \quad (22.10)$$

This equation represents the distribution of free paths. It is plotted in Fig. 22.4. The area of the narrow vertical strip of thickness dx at a distance x from the origin represents dN , the number of molecules with free paths of lengths between x and $x + dx$.

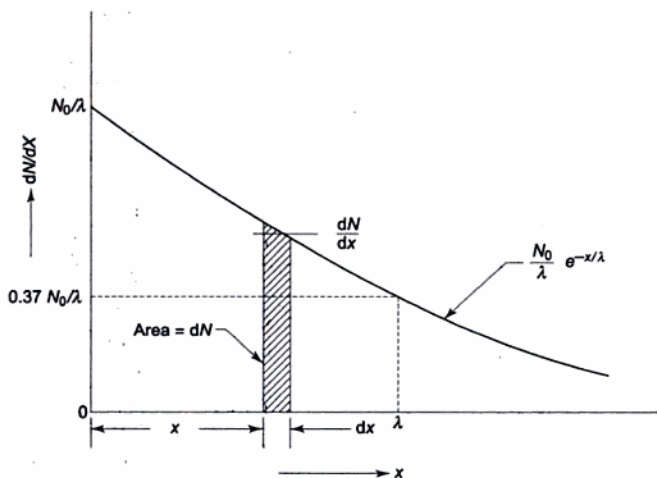

Fig. 22.4 Distribution of free paths

22.3 Transport Properties

A simple treatment based on the concept of the mean free path will now be given for four transport properties of a gas, viz., coefficient of viscosity, thermal conductivity, coefficient of diffusion and electrical conductivity, which govern respectively the transport of momentum, energy, mass, and electric charge within the gas by molecular motion.

22.3.1 Coefficient of Viscosity

Let us consider a gas flowing over a flat stationary plate. Due to viscous effect there is the growth of a boundary layer over the plate surface.

The velocity of fluid at the surface will be zero, and it gradually increases to free stream velocity as shown in Fig. 22.5, drawn for laminar flow. Let us imagine a surface $P-P$ within the gas at an arbitrary height from the plate, where the fluid velocity is u and the velocity gradient du/dy . The velocity u is superposed on the random thermal motion of the molecules.

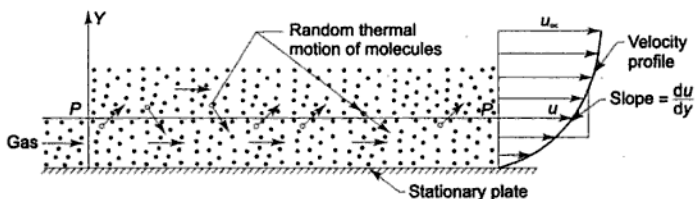

Fig. 22.5 Flow of a gas over a flat plate

Let us consider a volume element dV at a distance r from an element of area dA in the plane $P-P$, making an angle θ with normal to dA (Fig. 22.6), the plane $P-P$ being the same as shown in Fig. 22.5. The volume element is very small when compared with the physical dimensions of the system, but large enough to contain many molecules. The total number of molecules in dV is ndV , and the total number of collisions within dV in time dt is $\frac{1}{2} Zn \cdot dV \cdot dt$, where z is the collision frequency of a molecule, n is the number of molecules per unit volume, and the factor $\frac{1}{2}$ is required since two molecules are involved in each collision. Since two new free paths originate at each collision, the total number of new free paths, or molecules, originating in dV is $ZndVdt$. If we assume that these molecules are uniformly distributed in direction throughout the solid angle 4π , then the number headed towards the elemental area dA is:

$$\frac{zndVdt}{4\pi} dw$$

where dw is the solid angle subtended at the centre of dV by the area dA and is equal to $(dA \cos \theta)/r^2$.

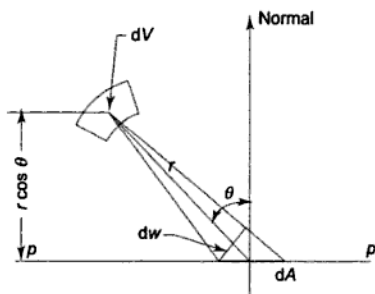

Fig. 22.6 Transfer of momentum across the plane $P-P$ by molecules in random thermal motion

The number of molecules that leave dV and reach dA without having made a collision may be found from the survival equation, Eq. (22.9), as given below:

$$\frac{zn \, dV \, dt}{4\pi} \, dw \, e^{-r/\lambda}$$

Since $dV = r^2 \sin \theta \cdot d\theta \cdot d\phi \, dr$, the number of molecules leaving dV in time dt and crossing dA without any collision is

$$\frac{1}{4\pi} \frac{dA \cos \theta}{r^2} \, Zn \, r^2 \sin \theta \, d\theta \, d\phi \, dr \, dt \, e^{-r/\lambda}$$

The total number of molecules crossing dA in time dt from the top is

$$\begin{aligned} N_{\text{total}} &= \frac{Zn \, dA \, dt}{4\pi} \int_{\theta=0}^{\pi/2} \sin \theta \cos \theta \, d\theta \int_{\phi=0}^{2\pi} d\phi \int_{r=0}^{\infty} e^{-r/\lambda} \, dr \\ &= \frac{Zn \, dA \, dt}{4\pi} \frac{1}{2} \, 2\pi \cdot \lambda = \frac{1}{4} \, Zn \, \lambda \, dA \, dt \quad (22.11) \end{aligned}$$

Since the dimensions of the physical system are very much larger than the molecular free path, the integral over r has been extended to infinity.

But $z = \bar{v}/\lambda$, so the number of molecules crossing the plane $P-P$ from the top (or bottom) per unit area and per unit time is $\frac{1}{4}n\bar{v}$. This is the same result obtained earlier in Sec. 21.4 without considering any intermolecular collision.

These molecules crossing the plane $P-P$ may be visualized as carrying properties characteristic of an average distance \bar{y} , either above or below the plane at which they made their last collisions before crossing. To find \bar{y} , each molecule crossing from dV is multiplied by its distance $r \cos \theta$ from the $P-P$ plane, it is integrated over θ , ϕ and r and then divided by N_{total} crossing the plane.

$$\bar{y} = \frac{\int y \, dN}{\int dN} = \frac{\int r \cos \theta \, dN}{N_{\text{total}}}$$

$$\begin{aligned}
 &= \frac{1}{N_{\text{total}}} \left[\int_r \int_\phi \int_\theta \frac{1}{4\pi} Z n dA dt \cdot e^{-r/\lambda} \sin \theta \cdot \cos \theta \cdot d\theta d\phi dr r \cos \theta \right] \\
 &= \frac{1}{N_{\text{total}}} \left[\frac{Z n dA dt}{4\pi} \int_{\theta=0}^{\pi/2} \sin \theta \cos^2 \theta d\theta \int_{\phi=0}^{2\pi} d\phi \int_{r=0}^{\infty} r e^{-r/\lambda} dr \right] \\
 &= \frac{\frac{Z n dA dt}{4\pi} \frac{1}{3} 2\pi \cdot \lambda^2}{\frac{1}{4} Z n \lambda dA dt} = \frac{2}{3} \lambda \quad (22.12)
 \end{aligned}$$

The velocity of gas at a height \bar{y} above PP is,

$$u + \frac{2}{3} \lambda \frac{du}{dy}$$

if the velocity gradient is considered constant over distances of the order of a free path.

The net momentum in the direction of flow carried across the plane by the molecules crossing PP from above per unit area and per unit time is:

$$\frac{1}{4} n \bar{v} m \left[u + \frac{2}{3} \lambda \frac{du}{dy} \right]$$

Similarly, the net momentum transfer from below is:

$$\frac{1}{4} n \bar{v} m \left[u - \frac{2}{3} \lambda \frac{du}{dy} \right]$$

The difference between the above two quantities is the net rate of transport of momentum per unit area and per unit time, given by:

$$\frac{1}{3} n m \bar{v} \lambda \frac{du}{dy}$$

From Newton's law of viscosity, this is the viscous force per unit area

$\tau = \mu \frac{du}{dy}$, where μ is the coefficient of viscosity.

Therefore,

$$\mu = \frac{1}{3} n m \bar{v} \lambda \quad (22.13)$$

Putting

$$\sigma = 1/\lambda n \text{ from Eq. (22.2),}$$

$$\mu = \frac{1}{3} \frac{m \bar{v}}{\sigma} \quad (22.14)$$

where σ is the collision cross-section.

For a gas with a Maxwellian velocity distribution,

$$\bar{v} = [8 KT/\pi m]^{1/2}, \lambda = 0.707/\sigma n$$

Therefore, from Eq. (22.13),

The net rate of energy transfer per unit area is the difference of the above two quantities, which gives:

$$\frac{1}{6} n \bar{v} f K \lambda \frac{dT}{dy}$$

By Fourier's law, this is given by:

$$q = k \frac{dT}{dy}$$

where k is the thermal conductivity of the gas. Therefore,

$$k = \frac{1}{6} n \bar{v} f K \lambda \quad (22.17)$$

or,
$$k = \frac{1}{6} \frac{\bar{v} f K}{\sigma} \quad (22.18)$$

For a gas with a Maxwellian velocity distribution,

$$\bar{v} = [8KT/\pi m]^{1/2} \text{ and } \lambda = 0.707/\sigma n$$

$$k = \frac{1}{3} \frac{fK}{\sigma} [KT/\pi m]^{1/2} \quad (22.19)$$

The above equation predicts that the thermal conductivity of a gas, like the viscosity, is independent of pressure or density, and *depends only on temperature*. It increases as the temperature increases.

For a monatomic gas, $f = 3$ and putting $\sigma = \pi d^2$,

$$k = \frac{1}{\pi^{3/2} d^2} \left[\frac{K^3 T}{m} \right]^{1/2}$$

Dividing Eq. (22.15) by Eq. (22.19),

$$\mu/k = 2m/fK \quad (22.20)$$

But $m = M/N_0$, $K = \bar{R}/N_0$, $c_v = \frac{f}{2} R = \frac{f}{2} \frac{\bar{R}}{M}$,

where M is the molecular weight and N_0 is the Avogadro's number. Therefore, on substitution in Eq. (22.20)

$$\mu c_v/k = 1 \quad (22.21)$$

or, Prandtl number, $Pr = \mu c_p/k = \gamma \quad (22.22)$

The results given by the Eqs (22.21) and (22.22) agree with the experimental values only as regards order of magnitude.

22.3.3 Coefficient of Diffusion

In a gaseous mixture, diffusion results from random molecular motion whenever there is a concentration gradient of any molecular species. Let us consider two different gases A and B at the same temperature and pressure on the two opposite sides of the partition in a vessel (Fig. 22.8). The number of

molecules per unit volume (p/KT) is, therefore, the same on both sides. When the partition is removed, both the gases diffuse into each other, and after a lapse of time both the gases are uniformly distributed throughout the entire volume. The diffusion process is often superposed by the hydrodynamic flow resulting from pressure differences, and the effects of molecules rebounding from the walls of the vessel. When more than one type of molecule is present, the rates of diffusion of one species into another are different. To simplify the problem we assume: (1) the molecules of a single species diffusing into others of the same species (self-diffusion), (2) the containing vessel very large compared with the mean free path so that collisions with the walls can be neglected in comparison with collisions with other molecules, and (3) a uniform pressure maintained so that there is no hydrodynamic flow. Of course, if all the molecules are exactly alike, there would be no way experimentally to identify the diffusion process. However, the diffusion of molecules that are isotopes of the same element is a practical example of the self-diffusion process.

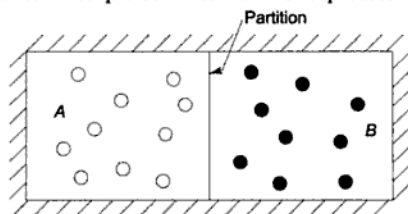

Fig. 22.8 Diffusion of gases A and B when the partition is removed

Let n denote the number of molecules per unit volume of one gas, blackened for identification (Fig. 22.9). Let us consider diffusion across an imaginary vertical plane y - y in the vessel. Let us also assume that n increases from left to

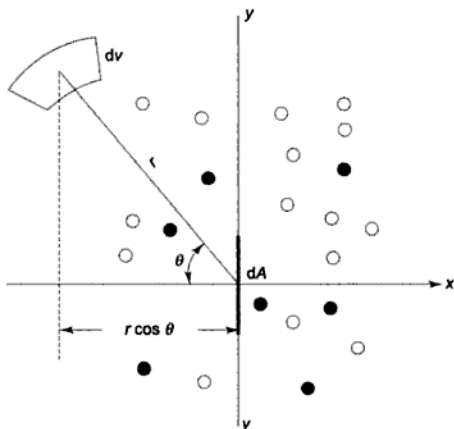

Fig. 22.9 Diffusion across an imaginary plane

From Eqs (22.23) and (22.27)

$$D = \frac{1}{3} Z \lambda^2 \quad (22.28)$$

Putting $z = \bar{v}/\lambda$,

$$D = \frac{1}{3} \bar{v} \lambda \quad (22.29)$$

For Maxwellian velocity distribution of the molecules,

$$\bar{v} = [8KT/\pi m]^{1/2} \text{ and } \lambda = 0.707/\sigma n_t$$

$$\therefore D = \frac{2}{3\sigma n_t} [KT/\pi m]^{1/2} \quad (22.30)$$

$$\text{or, } D = \frac{2}{3\pi^{3/2} d^2 n_t} [KT/m]^{1/2} \quad (22.31)$$

The equation applies to diffusion in a binary mixture of almost identical gases. Dividing Eq. (22.15) by Eq. (22.30),

$$\mu/D = n_t \cdot m = \rho$$

$$\text{or, Schmidt number } Sc = \mu/\rho D = 1 \quad (22.32)$$

Measured values of Schmidt number for the diffusion of isotopic tracer molecules yield values between 1.3 and 1.5, which indicate qualitative agreement of theory with measured data.

22.3.4 Electrical Conductivity

Conduction of electricity in a gas arises as a result of motion of the free electrons present in the gas. When high-energy atoms in the gas collide, some collisions cause ionization when an electron is separated from its atom, so that a negatively charged electron and a positively charged ion are produced from the neutral atom. Most gases at room temperature do not have many such high-energy molecules and thus have very few free electrons. At high temperatures, however, an appreciable number of electrons may be liberated and the gases may become highly conductive. In absence of external electrical fields, the electrons will be distributed uniformly throughout the gas volume. As an electrical field is impressed on the gas, the charged particles are accelerated with a force

$$F = q_e E = m_e \frac{dv_e}{dt} \quad (22.33)$$

where q_e is the charge on the electron and E is the electric field strength (volts per metre). Integrating Eq. (22.33)

$$v_e = \frac{dx_e}{dt} = \frac{q_e Et}{m_e}$$

At $t = 0$, $v_e = 0$, $x_e = 0$. Similarly, the velocity of a single charged ion is:

$$v_{e_d} = \frac{q_e E}{m_e} \frac{4}{\sigma n} \left[\frac{\pi m_e}{8 K T} \right]^{1/2}$$

Using

$$n = p/KT,$$

$$v_{e_d} = \frac{4 q_e E}{\sigma p} \left[\frac{\pi K T}{8 m_e} \right]^{1/2} \quad (22.37)$$

where σ is the atomic cross-section.

The flux of charge across unit area per unit time is called the *current density*, J . The current density is defined with respect to the average drift velocity by the following equation,

$$J = n_e q_e v_{e_d} \quad (22.38)$$

where n_e is the number density of electrons. The motion of the ions is neglected. From Eqs (22.36) and (22.38),

$$J = \frac{q_e^2 n_e \tau_e}{m_e} E \quad (22.39)$$

The current density is proportional, to the electric field and the constant of proportionality is called the *electrical conductivity*, σ_e

$$J = \sigma_e E$$

From Eq. (22.39), σ_e is given by

$$\sigma_e = \frac{q_e^2 n_e \tau_e}{m_e}$$

Putting

$$\lambda_e = \bar{v} \tau_e = 4/\sigma n,$$

$$\begin{aligned} \sigma_e &= \frac{q_e^2 n_e}{m_e} \frac{4}{\sigma n} \left[\frac{\pi m_e}{8 K T} \right]^{1/2} \\ &= \frac{q_e^2 n_e}{\sigma n} \left[\frac{2 \pi}{m_e K T} \right]^{1/2} \end{aligned} \quad (22.41)$$

The electron drift velocity v_{e_d} is also proportional to the electric field and the proportionality constant is called the electron mobility, μ_e

$$v_{e_d} = \mu_e E$$

From Eq. (22.36)

$$\mu_e = (q_e \tau_e)/m_e$$

Again, using

$$\lambda_e = \bar{v} \tau_e = 4/\sigma n,$$

$$\mu_e = \frac{q_e}{m_e} \frac{4}{\sigma n} \left[\frac{\pi m_e}{8 K T} \right]^{1/2} = \frac{q_e}{\sigma n} \left[\frac{2 \pi}{m_e K T} \right]^{1/2} \quad (22.42)$$

$$N = -\frac{N_0}{\lambda} \int_{10}^{10} e^{-x/\lambda} dx = \text{zero} \quad \text{Ans.}$$

Example 22.4 Calculate the coefficient of viscosity of oxygen at 1 atm pressure and 300 K.

Solution

From previous examples, we have

$$m = 5.31 \times 10^{-26} \text{ kg/molecule}$$

$$\bar{v} = 445 \text{ m/s}$$

$$\sigma = 3.84 \times 10^{-19} \text{ m}^2$$

Therefore,

$$\begin{aligned} \mu &= \frac{1}{3} \frac{m \bar{v}}{\sigma} \\ &= \frac{(5.31 \times 10^{-26}) \text{ kg/molecule} \times 445 \text{ m/s}}{3 \times 3.84 \times 10^{-19} \text{ m}^2/\text{molecule}} \\ &= 2.05 \times 10^{-5} \text{ kg/ms} \quad \text{Ans.} \\ &= 2.05 \times 10^{-5} \text{ Ns/m}^2 \quad \text{Ans.} \end{aligned}$$

Example 22.5 Calculate the thermal conductivity of oxygen at 1 atm, 300 K.

Solution

For oxygen, a diatomic gas, the degree of freedom $f = 5$.

$$\bar{v} = [8KT/\pi m]^{1/2} = 445 \text{ m/s}$$

$$\sigma = \pi d^2 = 3.84 \times 10^{-19} \text{ m}^2$$

$$k = \frac{1}{6} \frac{\bar{v} f K}{\sigma}$$

$$= \frac{1}{6} \frac{445 \text{ m/s} \times 5 \times 1.38 \times 10^{-23} \text{ J/molecule K}}{3.84 \times 10^{-19} \text{ m}^2/\text{molecule}}$$

$$= 0.0133 \text{ W/mK} \quad \text{Ans.}$$

If the gas has Maxwellian velocity distribution,

$$\begin{aligned} k &= \frac{1}{3} \frac{fK}{\sigma} [KT/\pi m]^{1/2} \\ &= \frac{1}{3} \frac{5 \times 1.38 \times 10^{-23} \text{ J/molecule K}}{3.84 \times 10^{-19} \text{ m}^2/\text{molecule}} \\ &\quad \times \left[\frac{1.38 \times 10^{-23} \text{ (J/molecule K)} \times 300}{\pi \times 5.31 \times 10^{-26} \text{ kg/molecule}} \right] \end{aligned}$$

$$\begin{aligned}
 &= \frac{5 \times 1.38 \times 10^{-23}}{3 \times 3.84 \times 10^{-19}} \frac{J}{m^2 K} \left[\frac{1.38 \times 10^{-23} \times 300}{\pi \times 5.31 \times 10^{-26}} \right]^{1/2} \text{ m/s} \\
 &= 0.0095 \text{ W/mK} \qquad \text{Ans.}
 \end{aligned}$$

Example 22.6 Determine the pressure in a cathode-ray tube such that 90% of the electrons leaving the cathode ray reach the anode 20 cm away without making a collision. The diameter of an ion is 3.6×10^{-10} m and the electron temperature is 2000 K. Use the electronic mean free path $\lambda_e = 4/\sigma n$, where σ is the cross-section of the ion.

Solution

The survival equation is

$$N = N_0 e^{-x/\lambda}$$

where $N = 0.9 N_0$ and $x = 0.2$ m

$$0.9 = e^{-x/\lambda}$$

$$x/\lambda = 0.1053$$

$$\lambda = 0.2/0.1053 = 1.9 \text{ m}$$

$$\begin{aligned}
 \sigma &= 4\pi r^2 = 4\pi \times (1.8 \times 10^{-10})^2 \\
 &= 40.715 \times 10^{-20} \text{ m}^2
 \end{aligned}$$

$$\lambda_e = \frac{4}{\sigma n} = \frac{4}{40.715 \times 10^{-20} \times n} = 1.9 \text{ m}$$

$$n = \frac{4}{40.715 \times 10^{-20} \times 1.9} = 5.17 \times 10^{18} \text{ molecules/m}^3$$

Pressure in the cathode ray tube

$$\begin{aligned}
 p &= nKT \\
 &= 5.17 \times 10^{18} \times 1.38 \times 10^{-23} \times 2000 \text{ N/m}^2 \\
 &= 14.27 \times 10^{-2} = 0.1427 \text{ Pa} \qquad \text{Ans.}
 \end{aligned}$$

Example 22.7 Oxygen gas is contained in a one-litre flask at atmospheric pressure and 300 K. (a) How many collisions per second are made by one molecule with the other molecules? (b) How many molecules strike one sq. cm of the flask per second? (c) How many molecules are there in the flask? Take radius of oxygen molecule as 1.8×10^{-10} m.

Solution

(a) Number of molecules in the flask at

$$1 \text{ atm, } 300 \text{ K} = N/V = n = p/KT$$

$$\begin{aligned}
 &= \frac{101.325 \times 1000 \text{ N/m}^2}{1.38 \times 10^{-23} \text{ J/molecule} \cdot \text{K} \times 300 \text{ K}}
 \end{aligned}$$

anode, 20 cm away, without making a collision? Take for ion $\sigma = 4.07 \times 10^{-19} \text{ m}^2$ and $T = 2000 \text{ K}$.

Solution

The survival equation is

$$N = N_0 e^{-x/\lambda}$$

Here,

$$N = 0.9 N_0, x = 0.2 \text{ m}$$

$$0.9 = e^{-x/\lambda}$$

$$e^{x/\lambda} = 1.111$$

$$x/\lambda = \ln 1.111$$

$$= 0.2/0.105 \cong 2 \text{ m}$$

$$\text{Electronic mean free path } \lambda_e = \frac{1}{\sigma n} = \frac{1}{4.07 \times 10^{-19} \times n} = 2 \text{ m}$$

$$n = 1.23 \times 10^{18} \text{ molecules/m}^3$$

Now, pressure $p = nKT$

$$= 1.23 \times 10^{18} \frac{\text{molecules}}{\text{m}^3} \times 1.38 \times 10^{-23} \frac{\text{J}}{\text{molecule K}} \times 2000 \text{ K}$$

$$= 3.395 \times 10^{-2} \text{ N/m}^2$$

Ans.

Example 22.10 A tube 2 m long and 10^{-4} m^2 in cross-section contain CO_2 at atmospheric pressure and 0°C . The carbon atoms in one-half of the CO_2 molecules are radioactive isotope C^{14} . At time $t = 0$, all the molecules at the extreme left end of the tube contain radioactive carbon, and the number of such molecules per unit volume decreases uniformly to zero at the other end of the tube. (a) What is the initial concentration gradient of radioactive molecules? (b) Initially, how many radioactive molecules per sec cross a cross-section at the mid-point of the tube from left to right? (c) How many cross from right to left? What is the initial net rate of diffusion of radioactive molecules across the cross-section? Take $\sigma = \pi r^2 = 4 \times 10^{-19} \text{ m}^2$.

Solution

(a) Number of molecules/ m^3 at 1 atm, 273 K

$$n = p/KT = \frac{101.325 \times 1000}{1.38 \times 10^{-23} \times 273} = 2.69 \times 10^{25} \text{ molecules/m}^3$$

Concentration gradient, $dn/dx = (-2.69 \times 10^{25})^2$

$$= -1.345 \times 10^{25} \text{ molecules/m}^4$$

Ans.

(b) $\bar{v} = [2.55 \text{ KT/m}]^{1/2}$

$$= \left[\frac{2.55 \times 1.38 \times 10^{-23} \times 273 \times 6.023 \times 10^{26}}{46} \right]^{1/2}$$

$$\bar{v} = 355 \text{ m/s}$$

$$\lambda = \frac{1}{\sigma n} = \frac{1}{2.69 \times 10^{25} \times 4 \times 10^{-19}} = 9.3 \times 10^{-6} \text{ m}$$

Number of molecules crossing from left to right per unit area per unit time:

$$\begin{aligned} \Gamma_{\rightarrow} &= \frac{1}{4} z n_0 \lambda - \frac{1}{6} z \lambda_2 \frac{dn}{dx} \\ &= \frac{1}{4} \bar{v} n_0 - \frac{1}{6} \bar{v} \lambda \frac{dn}{dx} \\ &= \frac{1}{4} \times 355 \times 2.69 \times 10^{25} - \frac{1}{6} \times 355 \times 9.3 \times 10^{-6} \times (-1.345 \times 10^{25}) \\ &= 2.39 \times 10^{27} + 7.4 \times 10^{21} \text{ molecules/m}^2\text{s} \quad \text{Ans.} \end{aligned}$$

(c) Number of molecules crossing from right to left per unit area per unit time:

$$\begin{aligned} \Gamma_{\leftarrow} &= \frac{1}{4} v n_0 + \frac{1}{6} z \lambda \frac{dn}{dx} \\ &= 2.39 \times 10^{27} - 7.4 \times 10^{21} \text{ molecules/m}^2\text{s} \quad \text{Ans.} \end{aligned}$$

Net rate of diffusion:

$$\begin{aligned} &= 7.4 \times 10^{21} \times 2 = 14.8 \times 10^{21} \text{ molecules/m}^2\text{s} \\ &= \frac{14.8 \times 10^{21} \times 46}{6.023 \times 10^{26}} \frac{\text{molecules}}{\text{m}^2\text{s}} \times \frac{\text{kg}}{\text{kgmol}} \times \frac{\text{kgmol}}{\text{molecules}} \\ &= 113 \times 10^{-5} = 11.3 \times 10^{-4} \text{ kg/m}^2\text{s} \\ &= 1.13 \text{ g/m}^2\text{s} \quad \text{Ans.} \end{aligned}$$

REVIEW QUESTIONS

- 22.1 Define mean free path, collision cross-section and collision frequency.
- 22.2 Show that $\lambda = 1/\sigma n$. What is electronic mean path? Why is it equal to $4/\sigma n$?
- 22.3 What is collision probability? Show that it is reciprocal of the mean free path.
- 22.4 Derive the survival equation: $N = N_0 e^{-x/\lambda}$ and explain its significance.
- 22.5 Show that 37% of the molecules in a gas have free paths longer than λ .
- 22.6 Explain graphically the distribution of free paths of gas molecules.
- 22.7 What are transport properties? What do they signify?
- 22.8 Show that the number of molecules crossing a plane in a gas per unit area and per unit time is equal to $\frac{1}{4} n \bar{v}$.
- 22.9 Show that the average distance from a plane in a gas where the molecules made their last collisions before crossing that plane is equal to $\frac{2}{3} \lambda$.
- 22.10 Show that the coefficient of viscosity of a gas is equal to $\frac{1}{3} n m \bar{v} \lambda$. With a Maxwellian velocity distribution of gas molecules, show that

$$\mu = \frac{2}{3\sigma} \left[\frac{mKT}{\pi} \right]^{1/2}$$

PROBLEMS

- 22.1 Calculate the collision frequency of a nitrogen molecule (a) at 300 K and 1 atm pressure, (b) at 300 K and 1 micron Hg abs. pressure. The radius of nitrogen molecule is 1.88×10^{-10} m.

Ans. (a) 7.35×10^9 collisions/s (b) 9.63×10^3 collisions/s

- 22.2 Calculate the collision rate of a molecule in a Maxwellian gas.

Ans. $\sqrt{2} \sigma n [8 KT/\pi m]^{1/2}$

- 22.3 The mean free path of a certain gas is 12 cm. If there are 10,000 free paths, how many are longer than (a) 5 cm, (b) 15 cm, (c) 50 cm? (d) How many are longer than 6 cm, but shorter than 12 cm? (e) How many are between 11.5 cm and 12.5 cm in length? (f) How many are between 11.9 and 12.1 cm in length? (g) How many have free paths exactly equal to 12 cm?

- 22.4 The mean free path of the molecules of a certain gas at 20°C is 3×10^{-5} m. (a) If the radius of the molecule is 3×10^{-10} m, find the pressure of the gas. (b) Calculate the number of collisions made by a molecule per metre of path.

- 22.5 The mean free path of the molecules of a certain gas at 298 K is 2.63×10^{-5} m, the radius of each molecule is 2.56×10^{-10} m. Compute the number of collisions made by a typical particle in moving a distance of 1 m, and also the pressure of the gas.

- 22.6 Determine the pressure in a cathode ray tube such that 95 per cent of the electrons leaving the cathode ray reach the anode 25 cm away without making a collision. The diameter of an ion is 3.6×10^{-10} m and the electron temperature is 2000 K. Use the electronic mean free path $\lambda_e = 4/\sigma n$, where σ is the cross-section of the ion.

- 22.7 A beam of electrons is projected from an electron gun into a gas at a pressure p , and the number remaining in the beam at a distance x from the gun is determined by allowing the beam to strike a collecting plate and measuring the current to the plate. The electron current emitted by the gun is 100 μ a, and the current to the plate when $x = 10$ cm and $p = 1$ mm Hg is 37 μ a. Determine (a) the electron mean free path, and (b) the current at 500 μ Hg pressure.

Ans. (a) 10 cm, (b) 60.7 μ a

- 22.8 A singly charged oxygen ion starts a free path in a direction at right angles to an electric field of intensity 100 volts/cm. The pressure is one atmosphere and the temperature 300 K. Calculate (a) the distance moved in the direction of the field in a time equal to that required to traverse one mean free path, (b) the ratio of the mean free path to this distance, (c) the average velocity in the direction of the field, (d) the ratio of the thermal velocity to this velocity, and (e) the ratio of the energy of thermal agitation to the energy gained from the field in one mean free path.

Ans. (a) 3.87×10^{-10} m, (c) 340 m/s, (e) 10^4

- 22.9 A spherical satellite d metre in diameter moves through the earth's atmosphere with a speed of \bar{v} m/s at an altitude where the number density is n molecules/ m^3 . How many molecules strike the satellite in 1 second? Derive an expression for the drag experienced by the satellite, assuming that all molecules which strike the sphere adhere to it.

- 22.10 Positive ions of nitrogen are subjected to an electric field of 10^6 volts/m. The ions move through nitrogen at 1 atm, 300 K. Calculate the average drift velocity of the ions and compare this velocity with the rms velocity of the gas. Also, calculate the distance an ion moves in the direction of the field in a time equal to that required to traverse one mean free path.
- 22.11 The viscosity of nitrogen at 1 atm pressure and 0°C is 16.6×10^{-6} Ns/m². Estimate the effective molecular diameter of nitrogen.
- 22.12 For a gas having molecular weight of 28.96 and the mean free path at 0°C and 1 atm pressure as 6.4×10^{-8} m, determine the coefficient of viscosity of the gas at N.T.P.
- 22.13 Estimate the thermal conductivity of nitrogen at 300 K, 1 atm pressure. The diameter of a nitrogen molecule is 1.85×10^{-10} m.
- 22.14 Given that the standard density of air is $\rho = 1.29 \times 10^{-3}$ g/cm³, $\bar{v} = 460$ m/s and the thermal conductivity is $K_{\text{th}} = 0.0548 \times 10^{-3}$ cal/cm-s-K, estimate the viscosity of air and compare your result with the measured value of 18.19×10^{-5} g/cm-s, at $p = 1$ atm and $T = 298$ K.
- 22.15 (a) Show how the concentration of a vapour varies when it diffuses into free air from the surface of an evaporating liquid at distance h below the mouth of a test tube to the mouth where the vapour concentration is zero.
(b) Calculate the coefficient of diffusion of ethyl alcohol ($\text{C}_2\text{H}_5\text{OH}$) vapour in air at 40°C when its surface sinks 2.7 mm/day and its surface is 20 mm from the mouth of the test tube. Its vapour pressure is 134 mm Hg. The density of liquid is 0.772 g/cm³.
- Ans.* (b) 0.139 cm²/s
- 22.16 A tube of length 50 cm and diameter 5 cm contains methane. Half of the molecules contain the radioactive carbon isotope, C^{14} . At time $t = 0$ there exists a linear concentration gradient in the tube, the methane at the extreme left consisting of 100% radioactive molecules. Determine the initial rate of diffusion of the radioactive isotope across a plane drawn through the centre of the tube, when $p = 1$ atm and $T = 300$ K. The viscosity of gas is 11×10^{-5} g/cm-sec.
- 22.17 Determine an expression for the electric field strength that will result in an average electron drift velocity which is 10% of the average thermal velocity. What is the value of the electric field strength in air at 1 atm and 300 K?

APPENDICES

APPENDIX A

Steam Tables*

Table A.1.1 Saturated Steam : Temperature Table

Temp. °C T	Pressure kPa P	Specific Volume, m ³ /kg		Internal Energy, kJ/kg				Enthalpy, kJ/kg				Entropy, kJ/kg K			
		Sat. Liquid v _f	Sat. Vapour v _g	Sat. Liquid u _f	Sat. Liquid u _f	Evap. u _{fg}	Sat. Vapour u _g	Sat. Liquid h _f	Sat. Liquid h _f	Evap. h _{fg}	Sat. Vapour h _g	Sat. Liquid s _f	Sat. Liquid s _f	Evap. s _{fg}	Sat. Vapour s _g
0.01	0.6113	0.001000	206.132	0.00	2375.3	2375.3	2375.3	0.00	2501.3	2501.3	0.0000	0.0000	9.1562	9.1562	
5	0.8721	0.001000	147.118	20.97	2361.3	2382.2	2382.2	20.98	2489.6	2510.5	0.0761	0.0761	8.9496	9.0257	
10	1.2276	0.001000	106.377	41.99	2347.2	2389.2	2389.2	41.99	2477.7	2519.7	0.1510	0.1510	8.7498	8.9007	
15	1.7051	0.001001	77.925	62.98	2333.1	2396.0	2396.0	62.98	2465.9	2528.9	0.2245	0.2245	8.5569	8.7813	
20	2.3385	0.001002	57.790	83.94	2319.0	2402.9	2402.9	83.94	2454.1	2538.1	0.2966	0.2966	8.3706	8.6671	
25	3.1691	0.001003	43.359	104.86	2304.9	2409.8	2409.8	104.87	2442.3	2547.2	0.3673	0.3673	8.1905	8.5579	
30	4.2461	0.001004	32.893	125.77	2290.8	2416.6	2416.6	125.77	2430.5	2556.2	0.4369	0.4369	8.0164	8.4533	
35	5.6280	0.001006	25.216	146.65	2276.7	2423.4	2423.4	146.66	2418.6	2565.3	0.5052	0.5052	7.8478	8.3530	
40	7.3837	0.001008	19.523	167.53	2262.6	2430.1	2430.1	167.54	2406.7	2574.3	0.5724	0.5724	7.6845	8.2569	
45	9.5934	0.001010	15.258	188.41	2248.4	2436.8	2436.8	188.42	2394.8	2583.2	0.6386	0.6386	7.5261	8.1647	
50	12.350	0.001012	12.032	209.30	2234.2	2443.5	2443.5	209.31	2382.7	2592.1	0.7037	0.7037	7.3725	8.0762	
55	15.758	0.001015	9.568	230.19	2219.9	2450.1	2450.1	230.20	2370.7	2600.9	0.7679	0.7679	7.2234	7.9912	
60	19.941	0.001017	7.671	251.09	2205.5	2456.6	2456.6	251.11	2358.5	2609.6	0.8311	0.8311	7.0784	7.9095	
65	25.033	0.001020	6.197	272.00	2191.1	2463.1	2463.1	272.03	2346.2	2618.2	0.8934	0.8934	6.9375	7.8309	
70	31.188	0.001023	5.042	292.93	2176.6	2469.5	2469.5	292.96	2333.8	2626.8	0.9548	0.9548	6.8004	7.7552	
75	38.578	0.001026	4.131	313.87	2162.0	2475.9	2475.9	313.91	2321.4	2635.3	1.0154	1.0154	6.6670	7.6824	
80	47.390	0.001029	3.407	334.84	2147.4	2482.2	2482.2	334.88	2308.8	2643.7	1.0752	1.0752	6.5369	7.6121	
85	57.834	0.001032	2.828	355.82	2132.6	2488.4	2488.4	355.88	2296.0	2651.9	1.1342	1.1342	6.4102	7.5444	
90	70.139	0.001036	2.361	376.82	2117.7	2494.5	2494.5	376.90	2283.2	2660.1	1.1924	1.1924	6.2866	7.4790	
95	84.554	0.001040	1.982	397.86	2102.7	2500.6	2500.6	397.94	2270.2	2668.1	1.2500	1.2500	6.1659	7.4158	
100	0.10135	0.001044	1.6729	418.91	2087.6	2506.5	2506.5	419.02	2257.0	2676.0	1.3068	1.3068	6.0480	7.3548	

* Adapted from Joseph H. Keenan, Frederick G. Keyes, Philip G. Hill, and Joan G. Moore, *Steam Tables*, John Wiley and Sons, New York, 1969.

Table A1.2 Saturated water: Pressure Table

Pressure kPa <i>P</i>	Temp. °C <i>T</i>	Specific Volume, m ³ /kg		Internal Energy, kJ/kg				Enthalpy, kJ/kg				Entropy, kJ/kg K			
		Sat. Liquid <i>v_f</i>	Sat. Vapour <i>v_g</i>	Sat. Liquid <i>u_f</i>	Sat. Vapour <i>u_g</i>	Sat. Liquid <i>h_f</i>	Sat. Vapour <i>h_g</i>	Sat. Liquid <i>s_f</i>	Sat. Vapour <i>s_g</i>	Sat. Liquid <i>h_f</i>	Sat. Vapour <i>h_g</i>	Sat. Liquid <i>s_f</i>	Sat. Vapour <i>s_g</i>		
0.6113	0.01	0.001000	206.132	0	2375.3	2375.3	2375.3	0.00	2501.3	2501.3	0	9.1562	9.1562	9.1562	
1.0	6.98	0.001000	129.208	29.29	2355.7	2385.0	2385.0	29.29	2484.9	2514.2	0.1059	8.8697	8.9756	8.9756	
1.5	13.03	0.001001	87.980	54.70	2338.6	2393.3	2393.3	54.70	2470.6	2525.3	0.1956	8.6322	8.8278	8.8278	
2.0	17.50	0.001001	67.004	73.47	2326.0	2399.5	2399.5	73.47	2460.0	2533.5	0.2607	8.4629	8.7236	8.7236	
2.5	21.08	0.001002	54.254	88.47	2315.9	2404.4	2404.4	88.47	2451.6	2540.0	0.3120	8.3311	8.6431	8.6431	
3.0	24.08	0.001003	45.665	101.03	2307.5	2408.5	2408.5	101.03	2444.5	2545.5	0.3545	8.2231	8.5775	8.5775	
4.0	28.96	0.001004	34.800	121.44	2293.7	2415.2	2415.2	121.44	2432.9	2554.4	0.4226	8.0520	8.4746	8.4746	
5.0	32.88	0.001005	28.193	137.79	2282.7	2420.5	2420.5	137.79	2423.7	2561.4	0.4763	7.9187	8.3950	8.3950	
7.5	40.29	0.001008	19.238	168.76	2261.7	2430.5	2430.5	168.76	2406.0	2574.8	0.5763	7.6751	8.2514	8.2514	
10.0	45.81	0.001010	14.674	191.79	2246.1	2437.9	2437.9	191.81	2392.8	2584.6	0.6492	7.5010	8.1501	8.1501	
15.0	53.97	0.001014	10.022	225.90	2222.8	2448.7	2448.7	225.91	2373.1	2599.1	0.7548	7.2536	8.0084	8.0084	
20.0	60.06	0.001017	7.649	251.35	2205.4	2456.7	2456.7	251.38	2358.3	2609.7	0.8319	7.0766	7.9085	7.9085	
25.0	64.97	0.001020	6.204	271.88	2191.2	2463.1	2463.1	271.90	2346.3	2618.2	0.8930	6.9383	7.8313	7.8313	
30.0	69.10	0.001022	5.229	289.18	2179.2	2468.4	2468.4	289.21	2336.1	2626.3	0.9439	6.8247	7.7686	7.7686	
40.0	75.87	0.001026	3.993	317.51	2159.5	2477.0	2477.0	317.55	2319.2	2636.7	1.0258	6.6441	7.6700	7.6700	
50.0	81.33	0.001030	3.240	340.42	2143.4	2483.8	2483.8	340.47	2305.4	2645.9	1.0910	6.5029	7.5939	7.5939	
75.0	91.77	0.001037	2.217	384.29	2112.4	2496.7	2496.7	384.36	2278.6	2663.0	1.2129	6.2434	7.4563	7.4563	
MPa															
0.100	99.62	0.001043	1.6940	417.33	2088.7	2506.1	2506.1	417.44	2258.0	2675.5	1.3025	6.0568	7.3593	7.3593	
0.125	105.99	0.001048	1.3749	444.16	2069.3	2513.5	2513.5	444.30	2241.1	2685.3	1.3739	5.9104	7.2843	7.2843	
0.150	111.37	0.001053	1.1593	466.92	2052.7	2519.6	2519.6	467.08	2226.5	2693.5	1.4335	5.7897	7.2232	7.2232	
0.175	116.06	0.001057	1.0036	486.78	2038.1	2524.9	2524.9	486.97	2213.6	2700.5	1.4848	5.6868	7.1717	7.1717	
0.200	120.23	0.001061	0.8857	504.47	2025.0	2529.5	2529.5	504.68	2202.0	2706.6	1.5300	5.5970	7.1271	7.1271	
0.225	124.00	0.001064	0.7933	520.45	2013.1	2533.6	2533.6	520.69	2191.3	2712.0	1.5705	5.5173	7.0878	7.0878	
0.250	127.43	0.001067	0.7187	535.08	2002.1	2537.2	2537.2	535.34	2181.5	2716.9	1.6072	5.4455	7.0526	7.0526	

Pressure MPa P	Temp. $^{\circ}\text{C}$ T	Specific Volume, m^3/kg		Internal Energy, kJ/kg				Enthalpy, kJ/kg				Entropy, $\text{kJ}/\text{kg K}$			
		Sat. Liquid v_f	Sat. Vapour v_g	Sat. Liquid u_f	Evap. u_{fg}	Sat. Vapour u_g	Sat. Liquid h_f	Evap. h_{fg}	Sat. Vapour h_g	Sat. Liquid s_f	Evap. s_{fg}	Sat. Vapour s_g			
2.50	223.99	0.001197	0.07998	959.09	1644.0	2603.1	962.09	1841.0	2803.1	2.5546	3.7028	6.2574			
2.75	229.12	0.001207	0.07275	982.65	1621.2	2603.8	985.97	1817.9	2803.9	2.6018	3.6190	6.2208			
3.00	233.90	0.001216	0.06668	1004.76	1599.3	2604.1	1008.41	1795.7	2804.1	2.6456	3.5412	6.1869			
3.25	238.38	0.001226	0.06152	1025.62	1578.4	2604.0	1029.60	1774.4	2804.0	2.6866	3.4685	6.1551			
3.50	242.60	0.001235	0.05707	1045.41	1558.3	2603.7	1049.73	1753.7	2803.4	2.7252	3.4000	6.1252			
4.0	250.40	0.001252	0.049778	1082.28	1520.0	2602.3	1087.29	1714.1	2801.4	2.7963	3.2737	6.0700			
5.0	263.99	0.001286	0.039441	1147.78	1449.3	2597.1	1154.21	1640.1	2794.3	2.9201	3.0532	5.9733			
6.0	275.64	0.001319	0.032440	1205.41	1384.3	2589.7	1213.32	1571.0	2784.3	3.0266	2.8625	5.8891			
7.0	285.88	0.001351	0.027370	1257.51	1323.0	2580.5	1266.97	1505.1	2772.1	3.1210	2.6922	5.8132			
8.0	295.06	0.001384	0.023518	1305.54	1264.3	2569.8	1316.61	1441.3	2757.9	3.2067	2.5365	5.7431			
9.0	303.40	0.001418	0.020484	1350.47	1207.3	2557.8	1363.23	1378.9	2742.1	3.2857	2.3915	5.6771			
10.0	311.06	0.001452	0.018026	1393.00	1151.4	2544.4	1407.53	1317.1	2724.7	3.3595	2.2545	5.6140			
11.0	318.15	0.001489	0.015987	1433.68	1096.1	2529.7	1450.05	1255.5	2705.6	3.4294	2.1233	5.5527			
12.0	324.75	0.001527	0.014263	1472.92	1040.8	2513.7	1491.24	1193.6	2684.8	3.4961	1.9962	5.4923			
13.0	330.93	0.001567	0.012780	1511.09	985.0	2496.1	1531.46	1130.8	2662.2	3.5604	1.8718	5.4323			
14.0	336.75	0.001611	0.011485	1548.53	928.2	2476.8	1571.08	1066.5	2637.5	3.6231	1.7485	5.3716			
15.0	342.24	0.001658	0.010338	1585.58	869.8	2455.4	1610.45	1000.0	2610.5	3.6847	1.6250	5.3097			
16.0	347.43	0.001711	0.009306	1622.63	809.1	2431.7	1650.00	930.6	2580.6	3.7460	1.4995	5.2454			
17.0	352.37	0.001770	0.008365	1660.16	744.8	2405.0	1690.25	856.9	2547.2	3.8078	1.3698	5.1776			
18.0	357.06	0.001840	0.007490	1698.86	675.4	2374.3	1731.97	777.1	2509.1	3.8713	1.2330	5.1044			
19.0	361.54	0.001924	0.006657	1739.87	598.2	2338.1	1776.43	688.1	2464.5	3.9387	1.0841	5.0227			
20.0	365.81	0.002035	0.005834	1785.47	507.6	2293.1	1826.18	583.6	2409.7	4.0137	0.9132	4.9269			
21.0	369.89	0.002206	0.004953	1841.97	388.7	2230.7	1888.30	446.4	2334.7	4.1073	0.6942	4.8015			
22.0	373.80	0.002808	0.003526	1973.16	108.2	2081.4	2034.92	124.0	2159.0	4.3307	0.1917	4.5224			
22.09	374.14	0.003155	0.003155	2029.58	0	2029.6	2099.26	0	2099.3	4.4297	0	4.4297			

T	P = 10 kPa (45.81)				P = 50 kPa (81.33)				P = 100 kPa (99.62)			
	v	u	h	s	v	u	h	s	v	u	h	s
Sat.	14.674	2437.9	2584.6	8.1501	3.240	2483.8	2645.9	7.5939	1.6940	2506.1	2675.5	7.3593
50	14.869	2443.9	2592.6	8.1749	—	—	—	—	—	—	—	—
100	17.196	2515.5	2687.5	8.4479	3.418	2511.6	2682.5	7.6947	1.6958	2506.6	2676.2	7.3614
150	19.513	2587.9	2783.0	8.6881	3.889	2585.6	2780.1	7.9400	1.9364	2582.7	2776.4	7.6133
200	21.825	2661.3	2879.5	8.9037	4.356	2659.8	2877.6	8.1579	2.1723	2658.0	2875.3	7.8342
250	24.136	2736.0	2977.3	9.1002	4.821	2735.0	2976.0	8.3555	2.4060	2733.7	2974.3	8.0332
300	26.445	2812.1	3076.5	9.2812	5.284	2811.3	3075.5	8.5372	2.6388	2810.4	3074.3	8.2157
400	31.063	2968.9	3279.5	9.6076	6.209	2968.4	3278.9	8.8641	3.1026	2967.8	3278.1	8.5434
500	35.679	3132.3	3489.0	9.8977	7.134	3131.9	3488.6	9.1545	3.5655	3131.5	3488.1	8.8341
600	40.295	3302.5	3705.4	10.1608	8.058	3302.2	3705.1	9.4177	4.0278	3301.9	3704.7	9.0975
700	44.911	3479.6	3928.7	10.4028	8.981	3479.5	3928.5	9.6599	4.4899	3479.2	3928.2	9.3398
800	49.526	3663.8	4159.1	10.6281	9.904	3663.7	4158.9	9.8852	4.9517	3663.5	4158.7	9.5652
900	54.141	3855.0	4396.4	10.8395	10.828	3854.9	4396.3	10.0967	5.4135	3854.8	4396.1	9.7767
1000	58.757	4053.0	4640.6	11.0392	11.751	4052.9	4640.5	10.2964	5.8753	4052.8	4640.3	9.9764
1100	63.372	4257.5	4891.2	11.2287	12.674	4257.4	4891.1	10.4858	6.3370	4257.3	4890.9	10.1658
1200	67.987	4467.9	5147.8	11.4090	13.597	4467.8	5147.7	10.6662	6.7986	4467.7	5147.6	10.3462
1300	72.603	4683.7	5409.7	11.5810	14.521	4683.6	5409.6	10.8382	7.2603	4683.5	5409.5	10.5182

T	P = 200 kPa (120.23)				P = 300 kPa (133.55)				P = 400 kPa (143.63)			
	v	u	h	s	v	u	h	s	v	u	h	s
Sat.	0.88573	2529.5	2706.6	7.1271	0.60582	2543.6	2725.3	6.9918	0.46246	2553.6	2738.5	6.8958
150	0.95964	2576.9	2768.8	7.2795	0.63388	2570.8	2761.0	7.0778	0.47084	2564.5	2752.8	6.9299
200	1.08034	2654.4	2870.5	7.5066	0.71629	2650.7	2865.5	7.3115	0.53422	2646.8	2860.5	7.1706
250	1.19880	2731.2	2971.0	7.7085	0.79636	2728.7	2967.6	7.5165	0.59512	2726.1	2964.2	7.3788
300	1.31616	2808.6	3071.8	7.8926	0.87529	2806.7	3069.3	7.7022	0.65484	2804.8	3066.7	7.5661
400	1.54930	2966.7	3276.5	8.2217	1.03151	2965.5	3275.0	8.0329	0.77262	2964.4	3273.4	7.8984
500	1.78139	3130.7	3487.0	8.5132	1.18669	3130.0	3486.0	8.3250	0.88934	3129.2	3484.9	8.1912
600	2.01297	3301.4	3704.0	8.7769	1.34136	3300.8	3703.2	8.5892	1.00555	3300.2	3702.4	8.4557
700	2.24426	3478.8	3927.7	9.0194	1.49573	3478.4	3927.1	8.8319	1.12147	3477.9	3926.5	8.6987
800	2.47539	3663.2	4158.3	9.2450	1.64994	3662.9	4157.8	9.0575	1.23722	3662.5	4157.4	8.9244

T	P = 1.00 MPa (179.91)					P = 1.20 MPa (187.99)					P = 1.40 MPa (195.07)				
	v	u	h	s		v	u	h	s		v	u	h	s	
600	0.40109	3296.8	3697.9	8.0289		0.33393	3295.6	3696.3	7.9434		0.28596	3294.4	3694.8	7.8710	
700	0.44779	3475.4	3923.1	8.2731		0.37294	3474.5	3922.0	8.1881		0.31947	3473.6	3920.9	8.1160	
800	0.49432	3660.5	4154.8	8.4996		0.41177	3659.8	4153.9	8.4149		0.35281	3659.1	4153.0	8.3431	
900	0.54075	3852.5	4392.9	8.7118		0.45051	3851.6	4392.2	8.6272		0.38606	3851.0	4391.5	8.5555	
1000	0.58712	4050.5	4637.6	8.9119		0.48919	4050.0	4637.0	8.8274		0.41924	4049.5	4636.4	8.7558	
1100	0.63345	4255.1	4888.5	9.1016		0.52783	4254.6	4888.0	9.0171		0.45239	4254.1	4887.5	8.9456	
1200	0.67977	4465.6	5145.4	9.2821		0.56646	4465.1	5144.9	9.1977		0.48552	4464.6	5144.4	9.1262	
1300	0.72608	4681.3	5407.4	9.4542		0.60507	4680.9	5406.9	9.3698		0.51864	4680.4	5406.5	9.2983	
P = 1.60 MPa (201.40)															
Sat.	0.12380	2595.9	2794.0	6.4217		0.11042	2598.4	2797.1	6.3793		0.09963	2600.3	2799.5	6.3408	
225	0.13287	2644.6	2857.2	6.5518		0.11673	2636.6	2846.7	6.4807		0.10377	2628.3	2835.8	6.4146	
250	0.14184	2692.3	2919.2	6.6732		0.12497	2686.0	2911.0	6.6066		0.11144	2679.6	2902.5	6.5452	
300	0.15862	2781.0	3034.8	6.8844		0.14021	2776.8	3029.2	6.8226		0.12547	2772.6	3023.5	6.7663	
350	0.17456	2866.0	3145.4	7.0693		0.15457	2862.9	3141.2	7.0099		0.13857	2859.8	3137.0	6.9562	
400	0.19005	2950.1	3254.2	7.2373		0.16847	2947.7	3250.9	7.1793		0.15120	2945.2	3247.6	7.1270	
500	0.22029	3119.5	3471.9	7.5389		0.19550	3117.8	3469.7	7.4824		0.17568	3116.2	3467.6	7.4316	
600	0.24998	3293.3	3693.2	7.8080		0.22199	3292.1	3691.7	7.7523		0.19960	3290.9	3690.1	7.7023	
700	0.27937	3472.7	3919.7	8.0535		0.24818	3471.9	3918.6	7.9983		0.22323	3471.0	3917.5	7.9487	
800	0.30859	3658.4	4152.1	8.2808		0.27420	3657.7	4151.3	8.2258		0.24668	3657.0	4150.4	8.1766	
900	0.33772	3850.5	4390.8	8.4934		0.30012	3849.9	4390.1	8.4386		0.27004	3849.3	4389.4	8.3895	
1000	0.36678	4049.0	4635.8	8.6938		0.32598	4048.4	4635.2	8.6390		0.29333	4047.9	4634.6	8.5900	
1100	0.39581	4253.7	4887.0	8.8837		0.35180	4253.2	4886.4	8.8290		0.31659	4252.7	4885.9	8.7800	
1200	0.42482	4464.2	5143.9	9.0642		0.37761	4463.7	5143.4	9.0096		0.33984	4463.2	5142.9	8.9606	
1300	0.45382	4679.9	5406.0	9.2364		0.40340	4679.4	5405.6	9.1817		0.36306	4679.0	5405.1	9.1328	
P = 2.00 MPa (212.42)															
Sat.	0.12380	2595.9	2794.0	6.4217		0.11042	2598.4	2797.1	6.3793		0.09963	2600.3	2799.5	6.3408	
225	0.13287	2644.6	2857.2	6.5518		0.11673	2636.6	2846.7	6.4807		0.10377	2628.3	2835.8	6.4146	
250	0.14184	2692.3	2919.2	6.6732		0.12497	2686.0	2911.0	6.6066		0.11144	2679.6	2902.5	6.5452	
300	0.15862	2781.0	3034.8	6.8844		0.14021	2776.8	3029.2	6.8226		0.12547	2772.6	3023.5	6.7663	
350	0.17456	2866.0	3145.4	7.0693		0.15457	2862.9	3141.2	7.0099		0.13857	2859.8	3137.0	6.9562	
400	0.19005	2950.1	3254.2	7.2373		0.16847	2947.7	3250.9	7.1793		0.15120	2945.2	3247.6	7.1270	
500	0.22029	3119.5	3471.9	7.5389		0.19550	3117.8	3469.7	7.4824		0.17568	3116.2	3467.6	7.4316	
600	0.24998	3293.3	3693.2	7.8080		0.22199	3292.1	3691.7	7.7523		0.19960	3290.9	3690.1	7.7023	
700	0.27937	3472.7	3919.7	8.0535		0.24818	3471.9	3918.6	7.9983		0.22323	3471.0	3917.5	7.9487	
800	0.30859	3658.4	4152.1	8.2808		0.27420	3657.7	4151.3	8.2258		0.24668	3657.0	4150.4	8.1766	
900	0.33772	3850.5	4390.8	8.4934		0.30012	3849.9	4390.1	8.4386		0.27004	3849.3	4389.4	8.3895	
1000	0.36678	4049.0	4635.8	8.6938		0.32598	4048.4	4635.2	8.6390		0.29333	4047.9	4634.6	8.5900	
1100	0.39581	4253.7	4887.0	8.8837		0.35180	4253.2	4886.4	8.8290		0.31659	4252.7	4885.9	8.7800	
1200	0.42482	4464.2	5143.9	9.0642		0.37761	4463.7	5143.4	9.0096		0.33984	4463.2	5142.9	8.9606	
1300	0.45382	4679.9	5406.0	9.2364		0.40340	4679.4	5405.6	9.1817		0.36306	4679.0	5405.1	9.1328	

T	P = 9.00 MPa (303.40)				P = 1.0,00 MPa (311.06)				P = 12.50 MPa (327.89)			
	v	u	h	s	v	u	h	s	v	u	h	s
800	0.05409	3632.5	4119.4	7.4597	0.04859	3629.0	4114.9	7.4077	0.03869	3620.0	4103.7	7.2965
900	0.05950	3829.2	4364.7	7.6782	0.05349	3826.3	4361.2	7.6272	0.04267	3819.1	4352.5	7.5181
1000	0.06485	4030.3	4613.9	7.8821	0.05832	4027.8	4611.0	7.8315	0.04658	4021.6	4603.8	7.7237
1100	0.07016	4236.3	4867.7	8.0739	0.06312	4234.0	4865.1	8.0236	0.05045	4228.2	4858.8	7.9165
1200	0.07544	4447.2	5126.2	8.2556	0.06789	4444.9	5123.8	8.2054	0.05430	4439.3	5118.0	8.0987
1300	0.08072	4662.7	5389.2	8.4283	0.07265	4660.4	5387.0	8.3783	0.05813	4654.8	5381.4	8.2717
P = 15 MPa (342.24)												
Sat.	.010338	2455.4	2610.5	5.3097	.0079204	2390.2	2528.8	5.1418	.0058342	2293.1	2409.7	4.9269
350	.011470	2520.4	2692.4	5.4420	.0017139	1632.0	1662.0	3.7612	.0016640	1612.3	1645.6	3.7280
400	.015649	2740.7	2975.4	5.8810	.0124477	2685.0	2902.8	5.7212	.0099423	2619.2	2818.1	5.5539
450	.018446	2879.5	3156.2	6.1403	.0151740	2844.2	3109.7	6.0182	.0126953	2806.2	3060.1	5.9016
500	.020800	2996.5	3308.5	6.3442	.0173585	2970.3	3274.0	6.2382	.0147683	2942.8	3238.2	6.1400
550	.022927	3104.7	3448.6	6.5198	.0192877	3083.8	3421.4	6.4229	.0165553	3062.3	3393.5	6.3347
600	.024911	3208.6	3582.3	6.6775	.0210640	3191.5	3560.1	6.5866	.0181781	3174.0	3537.6	6.5048
650	.026797	3310.4	3712.3	6.8223	.0227372	3296.0	3693.9	6.7356	.0196929	3281.5	3675.3	6.6582
700	.028612	3410.9	3840.1	6.9572	.0243365	3398.8	3824.7	6.8736	.0211311	3386.5	3809.1	6.7993
800	.032096	3611.0	4092.4	7.2040	.0273849	3601.9	4081.1	7.1245	.0238532	3592.7	4069.8	7.0544
900	.035457	3811.9	4343.8	7.4279	.0303071	3804.7	4335.1	7.3507	.0264463	3797.4	4326.4	7.2830
1000	.038748	4015.4	4596.6	7.6347	.0331580	4009.3	4589.5	7.5588	.0289666	4003.1	4582.5	7.4925
1100	.042001	4222.6	4852.6	7.8282	.0359695	4216.9	4846.4	7.7530	.0314471	4211.3	4840.2	7.6874
1200	.045233	4433.8	5112.3	8.0108	.0387605	4428.3	5106.6	7.9359	.0339071	4422.8	5101.0	7.8706
1300	.048455	4649.1	5375.9	8.1839	.0415417	4643.5	5370.5	8.1093	.0363574	4638.0	5365.1	8.0441
P = 20 MPa (365.81)												

T	P = 25 MPa			P = 30 MPa			P = 35 MPa		
	v	u	h	v	u	h	v	u	h
375	.001973	1798.6	1847.9	.001789	1737.8	1791.4	.001700	1702.9	1762.4
400	.006004	2430.1	2580.2	.002790	2067.3	2151.0	.002100	1914.0	1987.5
425	.007882	2609.2	2806.3	.005304	2455.1	2614.2	.003428	2253.4	2373.4
450	.009162	2720.7	2949.7	.006735	2619.3	2821.4	.004962	2498.7	2672.4
500	.011124	2884.3	3162.4	.008679	2820.7	3081.0	.006927	2751.9	2994.3
550	.012724	3017.5	3335.6	.010168	2970.3	3275.4	.008345	2920.9	3213.0
600	.014138	3137.9	3491.4	.011446	3100.5	3443.9	.009527	3062.0	3395.5
650	.015433	3251.6	3637.6	.012596	3221.0	3598.9	.010575	3189.8	3559.9
700	.016647	3361.4	3777.6	.013661	3335.8	3745.7	.011533	3309.9	3713.5
800	.018913	3574.3	4047.1	.015623	3555.6	4024.3	.013278	3536.8	4001.5
900	.021045	3783.0	4309.1	.017448	3768.5	4291.9	.014883	3754.0	4274.9
1000	.023102	3990.9	4568.5	.019196	3978.8	4554.7	.016410	3966.7	4541.1
1100	.025119	4200.2	4828.2	.020903	4189.2	4816.3	.017895	4178.3	4804.6
1200	.027115	4412.0	5089.9	.022589	4401.3	5079.0	.019360	4390.7	5068.4
1300	.029101	4626.9	5354.4	.024266	4616.0	5344.0	.020815	4605.1	5333.6

T	P = 40 MPa			P = 50 MPa			P = 60 MPa		
	v	u	h	v	u	h	v	u	h
375	.0016406	1677.1	1742.7	.0015593	1638.6	1716.5	.0015027	1609.3	1699.5
400	.0019077	1854.5	1930.8	.0017309	1788.0	1874.6	.0016335	1745.3	1843.4
425	.0025319	2096.8	2198.1	.0020071	1959.6	2060.0	.0018165	1892.7	2001.7
450	.0036931	2365.1	2512.8	.0024862	2159.6	2283.9	.0020850	2053.9	2179.0
500	.0056225	2678.4	2903.3	.0038924	2525.5	2720.1	.0029557	2390.5	2567.9
600	.0080943	3022.6	3346.4	.006113	2942.0	3247.6	.0048345	2861.1	3151.2
650	.0090636	3158.0	3520.6	.0069657	3093.6	3441.8	.0055953	3028.8	3364.6
700	.0099415	3283.6	3681.3	.0077274	3230.5	3616.9	.0062719	3177.3	3553.6
800	.0115228	3517.9	3978.8	.0090761	3479.8	3933.6	.0074588	3441.6	3889.1
900	.0129626	3739.4	4257.9	.0102831	3710.3	4224.4	.0085083	3681.0	4191.5
1000	.0143238	3954.6	4527.6	.0114113	3930.5	4501.1	.0094800	3906.4	4475.2
1100	.0156426	4167.4	4793.1	.0124966	4145.7	4770.6	.0104091	4124.1	4748.6
1200	.0169403	4380.1	5057.7	.0135606	4359.1	5037.2	.0113167	4338.2	5017.2
1300	.0182292	4594.3	5323.5	.0146159	4572.8	5303.6	.0122155	4551.4	5284.3

Table A.1.4 Compressed Liquid Water

T	P = 5.00 MPa (263.99)			P = 10.00 MPa (311.06)			P = 15.00 MPa (342.24)			
	v	u	h	v	u	h	v	u	h	
Sat.	.0012859	1147.78	1154.21	.0014524	1393.00	1407.53	.0016581	1585.58	1610.45	3.6847
0	.0009977	0.03	5.02	.0009952	0.10	10.05	.0009928	0.15	15.04	0.0004
20	.0009995	83.64	88.64	.0009972	83.35	93.32	.0009950	83.05	97.97	0.2934
40	.0010056	166.93	171.95	.0010034	166.33	176.36	.0010013	165.73	180.75	0.5665
60	.0010149	250.21	255.28	.0010127	249.34	259.47	.0010105	248.49	263.65	0.8231
80	.0010268	333.69	338.83	.0010245	332.56	342.81	.0010222	331.46	346.79	1.0655
100	.0010410	417.50	422.71	.0010385	416.09	426.48	.0010361	414.72	430.26	1.2954
120	.0010576	501.79	507.07	.0010549	500.07	510.61	.0010522	498.39	514.17	1.5144
140	.0010768	586.74	592.13	.0010737	584.67	595.40	.0010707	582.64	598.70	1.7241
160	.0010988	672.61	678.10	.0010953	670.11	681.07	.0010918	667.69	684.07	1.9259
180	.0011240	759.62	765.24	.0011199	756.63	767.83	.0011159	753.74	770.48	2.1209
200	.0011530	848.08	853.85	.0011480	844.49	855.97	.0011433	841.04	858.18	2.3103
220	.0011866	938.43	944.36	.0011805	934.07	945.88	.0011748	929.89	947.52	2.4952
240	.0012264	1031.34	1037.47	.0012187	1025.94	1038.13	.0012114	1020.82	1038.99	2.6770
260	.0012748	1127.92	1134.30	.0012645	1121.03	1133.68	.0012550	1114.59	1133.41	2.8575
280				.0013216	1220.90	1234.11	.0013084	1212.47	1232.09	3.0392
300				.0013972	1328.34	1342.31	.0013770	1316.58	1337.23	3.2259
320							.0014724	1431.05	1453.13	3.4246
340							.0016311	1567.42	1591.88	3.6545

Table A.2 Thermodynamic Properties of Refrigerant-12*
(Dichlorodifluoromethane)

Table A.2.1 Saturated Refrigerant-12

Temperature °C	Pressure MPa	Specific Volume			Enthalpy			Entropy		
		Sat. Liquid v_f cm ³ /g	Sat. Vapour v_g m ³ /kg	Sat. Liquid h_f kJ/kg	Evap. h_{fg} kJ/kg	Sat. Vapour h_g kJ/kg	Sat. Liquid s_f kJ/kg K	Sat. Vapour s_g kJ/kg K		
-90	0.0028	0.608	4.415545	-43.243	189.618	146.375	-0.2084	0.8268		
-85	0.0042	0.612	3.037316	-38.968	187.608	148.640	-0.1854	0.8116		
-80	0.0062	0.617	2.138345	-34.688	185.612	150.924	-0.1630	0.7979		
-75	0.0088	0.622	1.537651	-30.401	183.625	153.224	-0.1411	0.7855		
-70	0.0123	0.627	1.127280	-26.103	181.640	155.536	-0.1197	0.7744		
-65	0.0168	0.632	0.841166	-21.793	179.651	157.857	-0.0987	0.7643		
-60	0.0226	0.637	0.637910	-17.469	177.653	160.184	-0.0782	0.7552		
-55	0.0300	0.642	0.491000	-13.129	175.641	162.512	-0.0581	0.7470		
-50	0.0391	0.648	0.383105	-8.772	173.611	164.840	-0.0384	0.7396		
-45	0.0504	0.654	0.302682	-4.396	171.558	167.163	-0.0190	0.7329		
-40	0.0642	0.659	0.241910	-0.000	169.479	169.479	-0.0000	0.7269		

* Adapted from *Fundamentals of Classical Thermodynamics* by G. J. Van Wylen and R. Sonntag, John Wiley, New York 1976, P. 667-673 (with the kind permission of the publishers, John Wiley & Sons, Inc, New York).

<i>t</i>	<i>v</i>	<i>h</i>	<i>s</i>	<i>v</i>	<i>h</i>	<i>s</i>	<i>v</i>	<i>h</i>	<i>s</i>
100.0	0.125901	254.339	0.9332	0.100238	253.936	0.9171	0.83127	253.530	0.9038
110.0	0.129483	261.147	0.9512	0.103134	260.770	0.9352	0.085566	260.391	0.9220
<i>0.60 MPa</i>									
20.0	0.045836	198.762	0.7199	0.035646	196.935	0.6999			
30.0	0.047971	205.428	0.7423	0.037464	203.814	0.7230	0.030422	202.116	0.7063
40.0	0.050046	212.095	0.7639	0.039214	210.656	0.7452	0.031966	209.154	0.7291
50.0	0.052072	218.779	0.7849	0.040911	217.484	0.7667	0.033450	216.141	0.7511
60.0	0.054059	225.488	0.8054	0.042565	224.315	0.7875	0.034887	223.104	0.7723
70.0	0.056014	232.230	0.8253	0.044184	232.161	0.8077	0.036285	230.062	0.7929
80.0	0.057941	239.012	0.8448	0.045774	238.031	0.8275	0.037653	237.027	0.8129
90.0	0.059846	245.837	0.8638	0.047340	244.932	0.8467	0.038995	244.009	0.8324
100.0	0.061731	252.707	0.8825	0.048886	251.869	0.8656	0.040316	251.016	0.8514
110.0	0.063600	259.624	0.9008	0.050415	258.845	0.8840	0.041619	258.053	0.8700
<i>0.80 MPa</i>									
40.0	0.026761	207.580	0.7148	0.022830	205.924	0.7016	0.019744	204.170	0.6982
50.0	0.028100	214.745	0.7373	0.024068	213.290	0.7248	0.020912	211.765	0.7131
60.0	0.029387	221.854	0.7590	0.025247	220.558	0.7469	0.022012	218.212	0.7358
70.0	0.030632	228.931	0.7799	0.026380	227.766	0.7682	0.023062	226.564	0.7575
80.0	0.031843	235.997	0.8002	0.027477	234.941	0.7888	0.024072	233.856	0.7785
90.0	0.033027	243.066	0.8199	0.028545	242.101	0.8088	0.025051	241.113	0.7987
100.0	0.034189	250.146	0.8392	0.029588	249.260	0.8283	0.026005	248.355	0.8184
110.0	0.035332	257.247	0.8579	0.030612	256.428	0.8472	0.026937	255.593	0.8376
<i>1.00 MPa</i>									
50.0	0.018366	210.162	0.7021	0.014483	206.661	0.6812			
60.0	0.019410	217.810	0.7254	0.015463	214.805	0.7060	0.012579	211.457	0.6876

Table A.3 Thermodynamic Properties of Refrigerant-22 (Monochlorodifluoromethane)
Table A.3.1 Saturated Refrigerant-22

Temp. °C	Abs. Press. MPa	Specific volume (m^3/kg)				Enthalpy (kJ/kg)				Entropy ($kJ/kg \cdot K$)			
		Sat. Liquid v_f	Evap. v_{fg}	Sat. Vapour v_g	Sat. Liquid h_f	Sat. Liquid h_f	Evap. h_{fg}	Vapour h_g	Sat. Liquid s_f	Sat. Liquid s_f	Evap. s_{fg}	Vapour s_g	Sat. Vapour s_g
-70	0.0205	0.000670	0.940268	0.94093	-30.607	249.425	218.180	-0.1401	1.2277	1.0876			
-65	0.0280	0.000676	0.704796	0.705478	-25.658	246.925	221.267	-0.1161	1.1862	1.0701			
-60	0.0375	0.000682	0.536470	0.537152	-20.652	244.354	223.702	-0.0924	1.1463	1.0540			
-55	0.0495	0.000689	0.414138	0.414827	-15.585	241.703	226.117	-0.0689	1.1079	1.0390			
-50	0.0644	0.000695	0.323862	0.324557	-10.456	238.965	228.509	-0.0457	1.0708	1.0251			
-45	0.0827	0.000702	0.256288	0.256990	-5.262	236.132	230.870	-0.0227	1.0349	1.0122			
-40	0.1049	0.000709	0.205036	0.205745	0	233.198	233.197	0	1.0002	1.0002			
-35	0.1317	0.000717	0.165683	0.166400	5.328	230.156	235.484	0.0225	0.9664	0.9889			
-30	0.1635	0.000725	0.135120	0.135844	10.725	227.001	237.726	0.0449	0.9335	0.9784			
-25	0.2010	0.000733	0.111126	0.111859	16.191	223.727	239.918	0.0670	0.9015	0.9685			
-20	0.2448	0.000741	0.092102	0.092843	21.728	220.327	242.055	0.0890	0.8703	0.9593			
-15	0.2957	0.000750	0.076876	0.077625	27.334	216.798	244.132	0.1107	0.8398	0.9505			
-10	0.3543	0.000759	0.064581	0.065340	33.012	213.132	246.144	0.1324	0.8099	0.9422			
-5	0.4213	0.000768	0.054571	0.055339	38.762	209.323	248.085	0.1538	0.7806	0.9344			
0	0.4976	0.000778	0.046357	0.047135	44.586	205.364	249.949	0.1751	0.7518	0.9269			
5	0.5838	0.000789	0.039567	0.040356	50.485	201.246	251.731	0.1963	0.7235	0.9197			
10	0.6807	0.000800	0.033914	0.034714	56.463	196.960	253.423	0.2173	0.6956	0.9129			
15	0.7891	0.000812	0.029176	0.029987	62.523	192.495	255.018	0.2382	0.6680	0.9062			
20	0.9099	0.000824	0.025179	0.026003	68.670	187.836	256.506	0.2590	0.6407	0.8997			
25	1.0439	0.000838	0.021787	0.022624	74.910	182.968	257.877	0.2797	0.6137	0.8934			
30	1.1919	0.000852	0.018890	0.019742	81.250	177.869	259.119	0.3004	0.5867	0.8871			

Table A.3.2 Superheated Refrigerant-22

Temp. °C	0.20 MPa			0.25 MPa			0.30 MPa		
	v m ³ /kg	h kJ/kg	s kJ/kg K	v m ³ /kg	h kJ/kg	s kJ/kg K	v m ³ /kg	h kJ/kg	s kJ/kg K
20	0.136509	269.273	1.07763	0.108292	268.476	1.05421	0.089469	267.667	1.03468
30	0.141681	275.992	1.10016	0.112508	275.267	1.07699	0.093051	274.531	1.05771
40	0.146809	282.796	1.12224	0.116681	282.132	1.09927	0.096588	281.460	1.08019
50	0.151902	289.686	1.14390	0.120815	289.076	1.12109	0.100085	288.460	1.10220
60	0.156963	296.664	1.16516	0.124918	296.102	1.14250	0.103550	295.535	1.12376
70	0.161997	303.731	1.18607	0.128993	303.212	1.16353	0.106986	302.689	1.14491
80	0.167008	310.890	1.20663	0.133044	310.409	1.18420	0.110399	309.924	1.16569
90	0.171999	318.139	1.22687	0.137075	317.692	1.20454	0.113790	317.241	1.18612
100	0.176972	325.480	1.24681	0.141089	325.063	1.22456	0.117164	324.643	1.20623
110	0.181931	332.912	1.26646	0.145086	332.522	1.24428	0.120522	332.129	1.22603
					0.50 MPa			0.60 MPa	
0	0.060131	252.051	0.95359	—	—	—	—	—	—
10	0.063060	259.023	0.97866	0.049355	257.108	0.95223	0.040180	255.109	0.92945
20	0.065915	266.010	1.00291	0.051751	264.295	0.97717	0.042280	262.517	0.95517
30	0.068710	273.029	1.02646	0.054081	271.483	1.00128	0.044307	269.888	0.97989
40	0.071455	280.092	1.04938	0.056358	278.690	1.02467	0.046276	277.250	1.00378
50	0.074160	287.209	1.07175	0.058590	285.930	1.04743	0.048198	284.622	1.02695
60	0.076830	294.386	1.09362	0.060786	293.215	1.06963	0.050081	292.020	1.04950
70	0.079470	301.630	1.11504	0.062951	300.552	1.09133	0.051931	299.456	1.07149
80	0.082085	308.944	1.13605	0.065090	307.949	1.11257	0.053754	306.938	1.09298
90	0.084679	316.332	1.15668	0.067206	315.410	1.13340	0.055553	314.475	1.11403
100	0.087254	323.796	1.17695	0.069303	322.939	1.15386	0.057332	322.071	1.13466
110	0.089813	331.339	1.19690	0.071384	330.539	1.17395	0.059094	329.731	1.15492
120	0.092358	338.961	1.21654	0.073450	338.213	1.19373	0.060842	337.458	1.17482
130	0.094890	346.664	1.23588	0.075503	345.963	1.21319	0.062576	345.255	1.19441

Table A.3.2 Superheated Refrigerant-22

Temp. °C	0.70 MPa			0.80 MPa			0.90 MPa		
	v m ³ /kg	h kJ/kg	s kJ/kg K	v m ³ /kg	h kJ/kg	s kJ/kg K	v m ³ /kg	h kJ/kg	s kJ/kg K
20	0.035487	260.667	0.93565	0.030366	258.737	0.91787	0.026355	256.713	0.90132
30	0.037305	268.240	0.96105	0.032034	266.533	0.94402	0.027915	264.760	0.92831
40	0.039059	275.769	0.98549	0.033632	274.243	0.96905	0.029397	272.670	0.95398
	0.70 MPa			0.80 MPa			0.90 MPa		
50	0.040763	283.282	1.00910	0.035175	281.907	0.99314	0.030819	280.497	0.97859
60	0.042424	290.800	1.03201	0.036674	289.553	1.01644	0.032193	288.278	1.00230
70	0.044052	298.339	1.05431	0.038136	297.202	1.03906	0.033528	296.042	1.02526
80	0.045650	305.912	1.07606	0.039568	304.868	1.06108	0.034832	303.807	1.04757
90	0.047224	313.527	1.09732	0.040974	312.565	1.08257	0.036108	311.590	1.06930
100	0.048778	321.192	1.11815	0.042359	320.303	1.10359	0.037363	319.401	1.09052
110	0.050313	328.914	1.13856	0.043725	328.087	1.12417	0.038598	327.251	1.11128
120	0.051834	336.696	1.15861	0.045076	335.925	1.14437	0.039817	335.147	1.13162
130	0.053341	344.541	1.17832	0.046413	343.821	1.16420	0.041022	343.094	1.15158
140	0.054836	352.454	1.19770	0.047738	351.778	1.18369	0.042215	351.097	1.17119
150	0.056321	360.435	1.21679	0.049052	359.799	1.20288	0.043398	359.159	1.19047
	1.00 MPa			1.20 MPa			1.40 MPa		
30	0.024600	262.912	0.91358	—	—	—	—	—	—
40	0.025995	271.042	0.93996	0.020851	267.602	0.91411	0.017120	263.861	0.89010
50	0.027323	279.046	0.96512	0.022051	276.011	0.94055	0.018247	272.766	0.91809
60	0.028601	286.973	0.98928	0.023191	284.263	0.96570	0.019299	281.401	0.94441
70	0.029836	294.859	1.01260	0.024282	292.415	0.98981	0.020295	289.858	0.96942
80	0.031038	302.727	1.03520	0.025336	300.508	1.01305	0.021248	298.202	0.99339
90	0.032213	310.599	1.05718	0.026359	308.570	1.03556	0.022167	306.473	1.01649
100	0.033364	318.488	1.07861	0.027357	316.623	1.05744	0.023058	314.703	1.03884

Temp. °C	2.50 MPa			3.00 MPa			3.50 MPa		
	v m ³ /kg	h kJ/kg	s kJ/kg K	v m ³ /kg	h kJ/kg	s kJ/kg K	v m ³ /kg	h kJ/kg	s kJ/kg K
100	0.011598	302.935	0.95939	0.009098	296.663	0.92881	0.007257	289.504	0.89872
110	0.012208	312.261	0.98405	0.009674	306.744	0.95547	0.007829	300.640	0.92818
120	0.012788	321.400	1.00760	0.010211	316.470	0.98053	0.008346	311.129	0.95520
130	0.013343	330.412	1.03023	0.010717	325.955	1.00435	0.008825	321.196	0.98047
140	0.013880	339.336	1.05210	0.011200	335.270	1.02718	0.009276	330.976	1.00445
150	0.014400	348.205	1.07331	0.011665	344.467	1.04918	0.009704	340.554	1.02736
160	0.014907	357.040	1.09395	0.012114	353.584	1.07047	0.010114	349.989	1.04940
170	0.015402	365.860	1.11408	0.012550	362.647	1.09116	0.010510	359.324	1.07071
180	0.015887	374.679	1.13376	0.012976	371.679	1.11131	0.010894	368.590	1.09138
190	0.016364	383.508	1.15303	0.013392	380.695	1.13099	0.011268	377.810	1.11151
200	0.016834	392.354	1.17192	0.013801	389.708	1.15024	0.011634	387.004	1.13115
4.00 MPa									
90	0.005037	265.629	0.82544	—	—	—	—	—	—
100	0.005804	280.997	0.86721	0.003334	253.042	0.78005	—	—	—
110	0.006405	293.748	0.90094	0.004255	275.919	0.84064	0.002432	243.278	0.74674
120	0.006924	305.273	0.93064	0.004851	291.362	0.88045	0.003333	272.385	0.82185
130	0.007391	316.080	0.95778	0.005335	304.469	0.91337	0.003899	290.253	0.86675
140	0.007822	326.422	0.98312	0.005757	316.379	0.94256	0.004345	304.757	0.90230
150	0.008226	336.446	1.00710	0.006139	327.563	0.96931	0.004728	317.633	0.93310
160	0.008610	346.246	1.02999	0.006493	338.266	0.99431	0.005071	329.553	0.96094
170	0.008978	355.885	1.05199	0.006826	348.633	1.01797	0.005386	340.849	0.98673
180	0.009332	365.409	1.07324	0.007142	358.760	1.04057	0.005680	351.715	1.01098
190	0.009675	374.853	1.09386	0.007444	368.713	1.06230	0.005958	362.271	1.03402
200	0.010009	384.240	1.11391	0.007735	378.537	1.08328	0.006222	372.602	1.05609
210	0.010335	393.593	1.13347	0.008018	388.268	1.10363	0.006477	382.764	1.07734
220	0.010654	402.925	1.15259	0.008292	397.932	1.12343	0.006722	392.801	1.09790

Table A.4.2 Superheated R-134a

Temp. °C	0.10 MPa			0.15 MPa			0.20 MPa		
	v m ³ /kg	h kJ/kg	s kJ/kg K	v m ³ /kg	h kJ/kg	s kJ/kg K	v m ³ /kg	h kJ/kg	s kJ/kg K
-25	0.19400	383.212	1.75058	—	—	—	—	—	—
-20	0.19860	387.215	1.76655	—	—	—	—	—	—
-10	0.20765	395.270	1.79775	0.13603	393.839	1.76058	0.10013	392.338	1.73276
0	0.21652	403.413	1.82813	0.14222	402.187	1.79171	0.10501	400.911	1.76474
10	0.22527	411.668	1.85780	0.14828	410.602	1.82197	0.10974	409.500	1.79562
20	0.23393	420.048	1.88689	0.15424	419.111	1.85150	0.11436	418.145	1.82563
30	0.24250	428.564	1.91545	0.16011	427.730	1.88041	0.11889	426.875	1.85491
40	0.25102	437.223	1.94355	0.16592	436.473	1.90879	0.12335	435.708	1.88357
50	0.25948	446.029	1.97123	0.17168	445.350	1.93669	0.12776	444.658	1.91171
60	0.26791	454.986	1.99853	0.17740	454.366	1.96416	0.13213	453.735	1.93937
70	0.27631	464.096	2.02547	0.18308	463.525	1.99125	0.13646	462.946	1.96661
80	0.28468	473.359	2.05208	0.18874	472.831	2.01798	0.14076	472.296	1.99346
90	0.29303	482.777	2.07837	0.19437	482.285	2.04438	0.14504	481.788	2.01997
100	0.30136	492.349	2.10437	0.19999	491.888	2.07046	0.14930	491.424	2.04614
					0.30 MPa			0.40 MPa	
0	0.082637	399.579	1.74284	—	—	—	—	—	—
10	0.086584	408.357	1.77440	0.071110	407.171	1.75637	0.051681	404.651	1.72611
20	0.090408	417.151	1.80492	0.074415	416.124	1.78744	0.054362	413.965	1.75844
30	0.093139	425.997	1.83460	0.077620	425.096	1.81754	0.056926	423.216	1.78947
40	0.097798	434.925	1.86357	0.080748	434.124	1.84684	0.059402	432.465	1.81949
50	0.101401	443.953	1.89195	0.083816	443.234	1.87547	0.061812	441.751	1.84868
60	0.104958	453.094	1.91980	0.086838	452.442	1.90354	0.064169	451.104	1.87718
70	0.108480	462.359	1.94720	0.089821	461.763	1.93110	0.066484	460.545	1.90510
80	0.111972	471.754	1.97419	0.092774	471.206	1.95823	0.068767	470.088	1.93252
90	0.115440	481.285	2.00080	0.095702	480.777	1.98495	0.071022	479.745	1.95948
100	0.118888	490.955	2.02707	0.098609	490.482	2.01131	0.073254	489.523	1.98604
110	0.122318	500.766	2.05302	0.101498	500.324	2.03734	0.075468	499.428	2.01223
120	0.125734	510.720	2.07866	0.104371	510.304	2.06305	0.077665	509.464	2.03809

Temp. °C	0.50 MPa			0.60 MPa			0.70 MPa		
	v m ³ /kg	h kJ/kg	s kJ/kg K	v m ³ /kg	h kJ/kg	s kJ/kg K	v m ³ /kg	h kJ/kg	s kJ/kg K
20	0.042256	411.645	1.73420	—	—	—	—	—	—
30	0.044457	421.221	1.76632	0.036094	419.093	1.74610	0.030069	416.809	1.72770
40	0.046557	430.720	1.79715	0.037958	428.881	1.77786	0.031781	426.933	1.76056
50	0.048581	440.205	1.82696	0.039735	438.589	1.80838	0.033392	436.895	1.79187
60	0.050547	449.718	1.85596	0.041447	448.279	1.83791	0.034929	446.782	1.82201
70	0.052467	459.290	1.88426	0.043108	457.994	1.86664	0.036410	456.655	1.85121
80	0.054351	468.942	1.91199	0.044730	467.764	1.89471	0.037848	466.554	1.87964
90	0.056205	478.690	1.93921	0.046319	477.611	1.92220	0.039251	476.507	1.90743
100	0.058035	488.546	1.96598	0.047883	487.550	1.94920	0.040627	486.535	1.93467
110	0.059845	498.518	1.99235	0.049426	497.594	1.97576	0.041980	496.654	1.96143
120	0.061639	508.613	2.01836	0.050951	507.750	2.00193	0.043314	506.875	1.98777
130	0.063418	518.835	2.04403	0.052461	518.026	2.02774	0.044633	517.207	2.01372
140	0.065184	529.187	2.06940	0.053958	528.425	2.05322	0.045938	527.656	2.03932
					0.90 MPa				
40	0.027113	424.860	1.74457	0.023446	422.642	1.72943	0.020473	420.249	1.71479
50	0.028611	435.114	1.77680	0.024868	433.235	1.76273	0.021849	431.243	1.74936
60	0.030024	445.223	1.80761	0.026192	443.595	1.79431	0.023110	441.890	1.78181
70	0.031375	455.270	1.83732	0.027447	453.835	1.82459	0.024293	452.345	1.81273
80	0.032678	465.308	1.86616	0.028649	464.025	1.85387	0.025417	462.703	1.84248
90	0.033944	475.375	1.89427	0.029810	474.216	1.88232	0.026497	473.027	1.87131
100	0.035180	485.499	1.92177	0.030940	484.441	1.91010	0.027543	483.361	1.89938
110	0.036392	495.698	1.94874	0.032043	494.726	1.93730	0.028561	493.736	1.92682
120	0.037584	505.988	1.97525	0.033126	505.088	1.96399	0.029556	504.175	1.95371
130	0.038760	516.379	2.00135	0.034190	515.542	1.99025	0.030533	514.694	1.98013
140	0.039921	526.880	2.02708	0.035241	526.096	2.01611	0.031495	525.305	2.00613
150	0.041071	537.496	2.05247	0.036278	536.760	2.04161	0.032444	536.017	2.03175

Temp. °C	3.0 MPa			3.50 MPa			4.0 MPa		
	v	h	s	v	h	s	v	h	s
	m ³ /kg	kJ/kg	kJ/kg K	m ³ /kg	kJ/kg	kJ/kg K	m ³ /kg	kJ/kg	kJ/kg K
90	0.005755	436.193	1.69950	—	—	—	—	—	—
100	0.006653	453.731	1.74717	0.004839	440.433	1.70386	—	—	—
110	0.007339	468.500	1.78623	0.005667	459.211	1.75355	0.004277	446.844	1.71480
120	0.007924	482.043	1.82113	0.006289	474.697	1.79346	0.005005	465.987	1.76415
130	0.008446	494.915	1.85347	0.006813	488.771	1.82881	0.005559	481.865	1.80404
140	0.008926	507.388	1.88403	0.007279	502.079	1.86142	0.006027	496.295	1.83940
150	0.009375	519.618	1.91328	0.007706	514.928	1.89216	0.006444	509.925	1.87200
160	0.009801	531.704	1.94151	0.008103	527.496	1.92151	0.006825	523.072	1.90271
170	0.010208	543.713	1.96892	0.008480	539.890	1.94980	0.007181	535.917	1.93203
180	0.010601	555.690	1.99565	0.008839	552.185	1.97724	0.007517	548.573	1.96028
190	0.010982	567.670	2.02180	0.009185	564.430	2.00397	0.007837	561.117	1.98766
200	0.011353	579.678	2.04745	0.009519	576.665	2.03010	0.008145	573.601	2.01432

Table A.5
Thermodynamic Properties of Ammonia

Table A.5.1 *Saturated Ammonia Table*

<i>T</i> (°C)	<i>p</i> (kPa)	Specific volume (<i>m</i> ³ /kg)		Enthalpy (kJ/kg)			Entropy (kJ/kg K)	
		Sat. liquid <i>v_f</i>	Sat. vapour, <i>v_g</i>	Sat. liquid, <i>h_f</i>	Evap., <i>h_{fg}</i>	Sat. vapour, <i>h_g</i>	Sat. liquid, <i>s_f</i>	Sat. vapour <i>s_g</i>
-50	40.88	0.001424	2.6254	-44.3	1416.7	1372.4	-0.1942	6.1561
-48	45.96	0.001429	2.3533	-35.5	1411.3	1375.8	-0.1547	6.1149
-46	51.55	0.001434	2.1140	-26.6	1405.8	1379.2	-0.1156	6.0746
-44	57.69	0.001439	1.9032	-17.8	1400.3	1382.5	-0.0768	6.0352
-42	64.42	0.001444	1.7170	-8.9	1394.7	1385.8	-0.0382	5.9967
-40	71.77	0.001449	1.5521	0.0	1389.0	1389.0	0.0000	5.9589
-38	79.80	0.001454	1.4058	8.9	1383.3	1392.2	0.0380	5.9220
-36	88.54	0.001460	1.2757	17.8	1377.6	1395.4	0.0757	5.8858
-34	98.05	0.001465	1.1597	26.8	1371.8	1398.5	0.1132	5.8504
-32	108.37	0.001470	1.0562	35.7	1365.9	1401.6	0.1504	5.8156
-30	119.55	0.001476	0.9635	44.7	1360.0	1404.6	0.1873	5.7815
-28	131.64	0.001481	0.8805	53.6	1354.0	1407.6	0.2240	5.7481
-26	144.70	0.001487	0.8059	62.6	1347.9	1410.5	0.2605	5.7153
-24	158.78	0.001492	0.7388	71.6	1341.8	1413.4	0.2967	5.6831
-22	173.93	0.001498	0.6783	80.7	1335.6	1416.2	0.3327	5.6515
-20	190.22	0.001504	0.6237	89.7	1329.3	1419.0	0.3684	5.6205
-18	207.71	0.001510	0.5743	98.8	1322.9	1421.7	0.4040	5.5900

Table A.5.2 Superheated Ammonia Table

Abs. Press. (kPa)	Temperature (°C)												
	(Sat. temp., °C)	-20	-10	0	10	20	30	40	50	60	70	80	100
50 (-46.54)	<i>v</i>	2.4474	2.5481	2.6482	2.7479	2.8479	2.9464	3.0453	3.1441	3.2427	3.3413	3.4397	
	<i>h</i>	1435.8	1457.0	1478.1	1499.2	1520.4	1541.7	1563.0	1584.5	1606.1	1627.8	1649.7	
	<i>s</i>	6.3256	6.4077	6.4865	6.5625	6.6360	6.7073	6.7766	6.8441	6.9099	6.9743	7.0372	
75 (-39.18)	<i>v</i>	1.6233	1.6915	1.7591	1.8263	1.8932	1.9597	2.0261	2.0933	2.1584	2.2244	2.2903	
	<i>h</i>	1433.0	1454.7	1476.1	1497.5	1518.9	1540.3	1561.8	1583.4	1605.1	1626.9	1648.9	
	<i>s</i>	6.1190	6.2028	6.2828	6.3597	6.4339	6.5058	6.5756	6.6434	6.7096	6.7742	6.8373	
100 (-33.01)	<i>v</i>	1.2110	1.2631	1.3145	1.3654	1.4160	1.4664	1.5165	1.5664	1.6163	1.6659	1.7155	1.8145
	<i>h</i>	1430.1	1452.2	1474.1	1495.7	1517.3	1538.9	1560.5	1582.2	1604.1	1626.0	1648.0	1692.6
	<i>s</i>	5.9695	6.0552	6.1366	6.2144	6.2894	6.3618	6.4321	6.5003	6.5668	6.6316	6.6950	6.8177
125 (-29.08)	<i>v</i>	0.9635	1.0059	1.0476	1.0889	1.1297	1.1703	1.2107	1.2509	1.2909	1.3309	1.3707	1.4501
	<i>h</i>	1427.2	1449.8	1472.0	1493.9	1515.7	1537.5	1559.3	1581.1	1603.0	1625.0	1647.2	1691.8
	<i>s</i>	5.8512	5.9389	6.0217	6.1006	6.1763	6.2494	6.3201	6.3887	6.4555	6.5206	6.5842	6.7072
150 (-25.23)	<i>v</i>	0.7984	0.8344	0.8697	0.9045	0.9388	0.9729	1.0068	1.0405	1.0740	1.1074	1.1408	1.2072
	<i>h</i>	1424.1	1447.3	1469.8	1492.1	1514.1	1536.1	1558.0	1580.0	1602.0	1624.1	1646.3	1691.1
	<i>s</i>	5.7526	5.8424	5.9266	6.0066	6.0831	6.1568	6.2280	6.2970	6.3641	6.4295	6.4933	6.6167
200 (-18.86)	<i>v</i>	0.6199	0.6471	0.6738	0.7001	0.7261	0.7519	0.7774	0.8029	0.8282	0.8533	0.9035	
	<i>h</i>	1442.0	1465.5	1488.1	1510.9	1533.2	1555.5	1577.7	1599.9	1622.2	1644.6	1689.6	
	<i>s</i>	5.6863	5.7737	5.8559	5.9342	6.0091	6.0813	6.1512	6.2189	6.2849	6.3491	6.4732	
250 (-13.67)	<i>v</i>	0.4910	0.5135	0.5354	0.5568	0.5780	0.5989	0.6196	0.6401	0.6605	0.6809	0.7212	
	<i>h</i>	1436.6	1461.0	1484.5	1507.6	1530.3	1552.9	1575.4	1597.8	1620.3	1642.8	1688.2	
	<i>s</i>	5.5609	5.6517	5.7465	5.8165	5.8928	5.9661	6.0368	6.1052	6.1717	6.2365	6.3613	
300 (-9.23)	<i>v</i>	0.4243	0.4430	0.4613	0.4792	0.4968	0.5113	0.5316	0.5488	0.5658	0.5997		
	<i>h</i>	1456.3	1480.6	1504.2	1527.4	1550.3	1573.0	1595.7	1618.4	1641.1	1686.7		
	<i>s</i>	5.5193	5.6366	5.7186	5.7963	5.8707	5.9423	6.0114	6.0785	6.1437	6.2693		
<i>v</i>	0.3605	0.3770	0.3929	0.4086	0.4239	0.4391	0.4541	0.4689	0.4837	0.5129			

Abs. press. (kPa)		Temperature (°C)																
		(Sat. temp., °C)	-20	-10	0	10	20	30	40	50	60	70	80	100	120	140	160	180
350 (-5.35)	<i>h</i>	1451.5	1478.5	1590.7	1521.4	1547.6	1570.7	1593.6	1616.5	1639.3	1685.2							
	<i>s</i>	5.4600	5.5502	5.6312	5.7135	5.7800	5.8615	5.9314	5.9990	6.0647	6.1910							
	<i>v</i>	0.3125	0.3274	0.3417	0.3556	0.3692	0.3826	0.3959	0.4090	0.4220	0.4478							
400 (-1.89)	<i>h</i>	1446.5	1472.4	1497.2	1521.3	1544.9	1568.3	1591.5	1614.5	1637.6	1683.7							
	<i>s</i>	5.3803	5.4735	5.5597	5.6405	5.7173	5.7907	5.8613	5.9296	5.9957	6.1228							
	<i>v</i>	0.2752	0.2887	0.3017	0.3143	0.3266	0.3387	0.3506	0.3624	0.3740	0.3971							
450 (1.26)	<i>h</i>	1441.3	1468.1	1493.6	1518.2	1542.2	1565.9	1589.3	1612.6	1635.8	1682.2							
	<i>s</i>	5.3078	5.4042	5.492.6	5.5752	5.6532	5.7275	5.7989	5.8678	5.9345	6.0623							
500 (4.14)	<i>v</i>	0.2698	0.2813	0.2926	0.3036	0.3144	0.3251	0.3357	0.3565	0.3771	0.3975							
	<i>h</i>	1489.9	1515.0	1539.5	1563.4	1587.1	1610.6	1634.0	1680.7	1727.5	1774.7							
	<i>s</i>	5.4314	5.5157	5.5950	5.6704	5.7425	5.8120	5.8793	6.0079	6.1301	6.2472							
600 (9.29)	<i>v</i>	0.2217	0.2317	0.2414	0.2508	0.2600	0.2691	0.2781	0.2957	0.3130	0.3302							
	<i>h</i>	1482.4	1508.6	1533.8	1558.5	1582.7	1606.6	1630.4	1677.7	1724.9	1772.4							
	<i>s</i>	5.3222	5.4102	5.4923	5.5697	5.6436	5.7144	5.7826	5.9129	6.0363	6.1541							
700 (13.81)	<i>v</i>	0.1874	0.1963	0.2048	0.2131	0.2212	0.2291	0.2369	0.2522	0.2672	0.2821							
	<i>h</i>	1474.5	1501.9	1528.1	1553.4	1578.2	1602.6	1626.8	1674.6	1722.4	1770.2							
	<i>s</i>	5.2259	5.3179	5.4029	5.4826	5.5582	5.6303	5.6997	5.8316	5.9562	6.0749							
800 (17.86)	<i>v</i>	0.1615	0.1696	0.1773	0.1848	0.1920	0.1991	0.2060	0.2196	0.2329	0.2459							
	<i>h</i>	1466.3	1495.0	1522.2	1548.3	1573.7	1598.6	1623.1	1671.6	1719.8	1768.0							
	<i>s</i>	5.1387	5.2351	5.3232	5.4053	5.4827	5.5562	5.6268	5.7603	5.8861	6.0057							
900 (21.54)	<i>v</i>	0.1488	0.1559	0.1627	0.1693	0.1757	0.1820	0.1882	0.1942	0.2061	0.2178							
	<i>h</i>	1488.0	1516.2	1543.0	1569.1	1594.4	1619.4	1668.5	1717.1	1765.7	1814.4							
	<i>s</i>	5.1593	5.2508	5.3354	5.4147	5.4897	5.5614	5.6968	5.8237	5.9442	6.0594							
<i>v</i>	0.1321	0.1388	0.1450	0.1511	0.1570	0.1627	0.1739	0.1847	0.1954	0.2058								

Temp. K	Carbon dioxide, CO ₂			Carbon monoxide, CO			Hydrogen, H ₂ Temp. K			
250	0.791	0.602	1.314	1.039	0.743	1.400	14.051	9.927	1.416	250
300	0.846	0.657	1.288	1.040	0.744	1.399	14.307	10.183	1.405	300
350	0.895	0.706	1.268	1.043	0.746	1.398	14.427	10.302	1.400	350
400	0.939	0.750	1.252	1.047	0.751	1.395	14.476	10.352	1.398	400
450	0.978	0.790	1.239	1.054	0.757	1.392	14.501	10.377	1.398	450
500	1.014	0.825	1.229	1.063	0.767	1.387	14.513	10.389	1.397	500
550	1.046	0.857	1.220	1.075	0.778	1.382	14.530	10.405	1.396	550
600	1.075	0.886	1.213	1.087	0.790	1.376	14.546	10.422	1.396	600
650	1.102	0.913	1.207	1.100	0.803	1.370	14.571	10.447	1.395	650
700	1.126	0.937	1.202	1.113	0.816	1.364	14.604	10.480	1.394	700
750	1.148	0.959	1.197	1.126	0.829	1.358	14.645	10.521	1.392	750
800	1.169	0.980	1.193	1.139	0.842	1.353	14.695	10.570	1.390	800
900	1.204	1.015	1.186	1.163	0.866	1.343	14.822	10.698	1.385	900
1000	1.234	1.045	1.181	1.185	0.888	1.335	14.983	10.859	1.380	1000

Source: Adapted from K. Wark, *Thermodynamics, 4th ed.*, McGraw-Hill, New York, 1983, as based on "Tables of Thermal Properties of Gases," NBS Circular 564, 1955.

Carbon Dioxide (CO ₂)		Carbon Monoxide (CO)		
$(h_f^o)_{288} = -393522 \text{ kJ/kmol}$		$(h_f^o)_{298} = -110529 \text{ kJ/kmol}$		
$M = 44.01$		$M = 28.01$		
Temp. K	$(\bar{h}^o - \bar{h}_{298}^o)$ kJ/kmol	\bar{s}^o kJ/kmol K	$(\bar{h}^o - \bar{h}_{298}^o)$ kJ/kmol	\bar{s}^o kJ/kmol K
0	-9364	0	-8669	0
100	-6456	179.109	-5770	165.850
200	-3414	199.975	-2858	186.025
298	0	213.795	0	197.653
300	67	214.025	54	197.833
400	4008	225.334	2975	206.234
500	8314	234.924	5929	212.828
600	12916	243.309	8941	218.313
700	17765	250.773	12021	223.062
800	22815	257.517	15175	227.271
900	28041	263.668	18397	231.006
1000	33405	269.325	21686	234.531
1100	38894	274.555	25033	237.719
1200	44484	279.417	28426	240.673
1300	50158	283.956	31865	243.426
1400	55907	288.216	35338	245.999
1500	61714	292.224	38848	248.421
1600	67580	296.010	42384	250.702
1700	73492	299.592	45940	252.861
1800	79442	302.993	49522	254.907
1900	85429	306.232	53124	256.852
2000	91450	309.320	56739	258.710

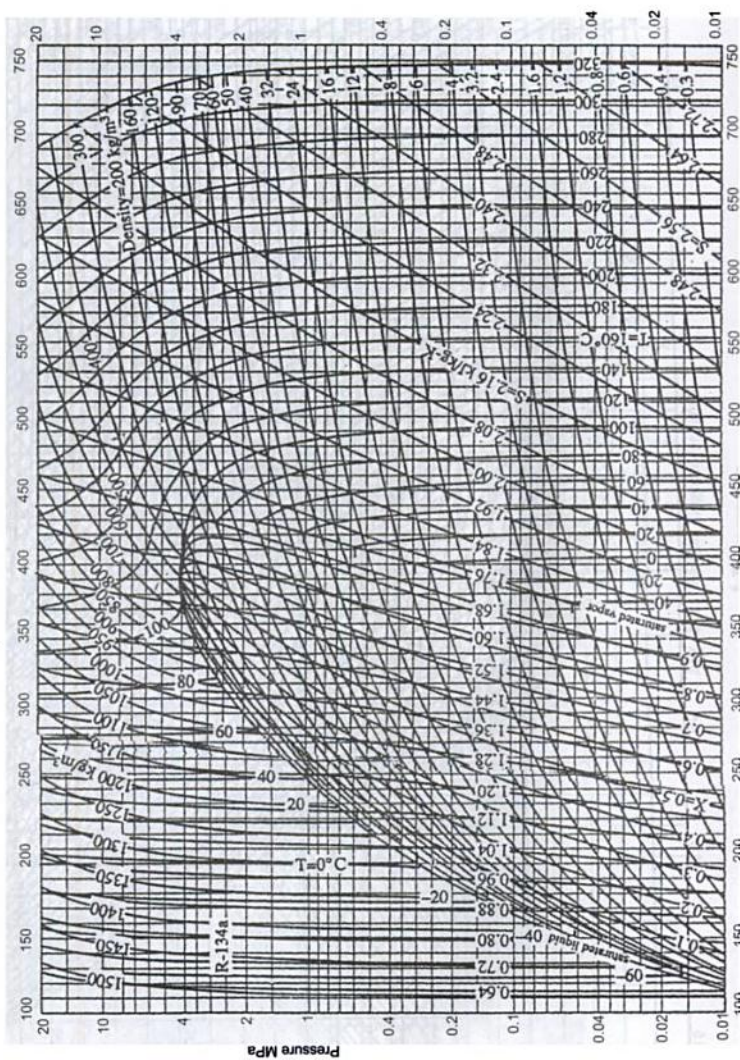

Fig. B.3 *p-h* diagram for refrigerant R-134a

Index

- Absolute entropy, [183](#), [664](#)
Absolute temperature scale, [131](#)
Absolute Zero, [133](#), [135](#), [808](#), [866](#)
Absorbents [592](#), [593](#)
Absorption refrigeration cycle, [591](#)
Absorptivity, [749](#)
Action integral, [773](#)
Activity, [657](#)
Adiabatic compressibility, [402](#)
Adiabatic demagnetisation, [429](#)
Adiabatic cooling, [621](#)
Adiabatic dissipation of work
Adiabatic evaporative cooling, [628](#)
Adiabatic flame temperature, [663](#)
Adiabatic process, [51](#), [336](#)
Adiabatic saturation temperature, [620](#)
Adiabatic wall, [51](#)
Adiabatic work, [179](#)
Affinity, [655](#)
Afterburner, [549](#)
Air cycle refrigeration, [596](#)
Air craft cabin cooling, [598](#)
Air craft propulsion, [548](#)
Air standard cycles, [524](#)
Air water vapour mixtures, [617](#)
Analyzer, [592](#)
Energy, [216](#)
Apparatus dew point, [624](#)
Approach, [630](#)
Aqua-ammonia refrigeration system, [591](#)
Atmospheric air, [617](#)
Available energy, [214](#), [218](#)
Availability, [230](#)
 Non-flow process, [231](#)
 Steady flow process, [230](#)
 Chemical reactions, [232](#)
Availability function, [226](#)
Avogadro's law, [328](#)
Avogadro's number [331](#)
Back pressure turbine, [487](#)
Barometer, [11](#)
Beattie-Bridgeman equation, [359](#), [364](#)
Benedict-Webb-Rubens equation, [359](#),
[364](#)
Bernoulli equation, [91](#)
Berthelot equation, [349](#)
Binary vapour cycles, [483](#)
Biot number, [735](#)
Black body radiation, [750](#)
Bohr-Sommerfeld rule, [773](#)
Boiler efficiency, [491](#)
Boltzmann constant, [183](#), [332](#)
Bose-Einstein statistics, [792](#)
Bose-Einstein distribution function, [793](#)
Bottoming cycle [485](#), [486](#)
Boyle temperature, [358](#)
Brake efficiency, [491](#)
Brake power, [44](#)
Brayton cycle, [533](#)

- Brayton-Rankine cycle, [551](#)
 Buoyancy force, [741](#)
 Bypass ratio, [550](#)
 Byproduct power, [487](#)
- Caloric theory of heat, [65](#)
 Calorimeter, [298](#)
 throttling, [298](#)
 separating and throttling, [300](#)
 electrical, [301](#)
 Caratheodory principle, [158](#)
 Carnot cycle, [120](#), [521](#)
 Carnot efficiency, [126](#), [135](#)
 Carnot refrigerator, [579](#)
 Carnot's theorem, [129](#)
 Cascade refrigeration cycle, [590](#)
 Causes of irreversibility, [121](#)
 Celsius temperature scale, [30](#)
 Characteristic gas constant, [331](#)
 Chemical dehumidification, [628](#)
 Chemical equilibrium, [5](#)
 Chemical exergy, [667](#)
 Chemical irreversibility, [138](#)
 Chemical potential, [419](#)
 Choking in nozzles, [703](#), [765](#)
 Claude liquefaction cycle, [600](#)
 Clausius equation of state, [868](#)
 Clausius inequality, [159](#)
 Clausius' statement of second law, [116](#)
 Clausius' theorem, [153](#)
 Clausius-Clapeyron equation, [409](#)
 Clearance, [347](#)
 volume, [347](#)
 Closed system, [2](#)
 Coefficient of diffusion, [905](#)
 Coefficient of performance, [118](#)
 Cogeneration plant, [488](#)
 Collision frequency, [897](#)
 Collision cross section, [897](#)
 Combined convection and radiation, [756](#)
 Combustion, [659](#)
 Compressed liquid region, [281](#)
 Compressible fluid, [696](#)
 Compressibility chart, [355](#), [356](#)
 Compressibility factor, [352](#)
 Compression ignition engine, [528](#)
 Compression ratio, [527](#)
 Compressor, [343](#)
 Condenser, [457](#)
 Conditions of equilibrium, [4](#), [126](#), [425](#)
 Conditions of stability, [427](#)
 Conduction, [727](#)
 Configuration factor, [750](#)
 Continuity equation, [84](#)
 Control surface, [3](#)
 Control volume, [2](#)
 Convection, [737](#)
 forced, [739](#), free, [741](#)
 Cooling and dehumidification, [624](#)
 Cooling tower, [629](#)
 Continuum, [7](#)
 Corresponding states, law of, [351](#), [357](#)
 Counterflow heat exchanger, [744](#)
 Coupled cycles, [486](#)
 Co-volume, [349](#)
 Criterion of stability, [425](#)
 Critical pressure, [282](#)
 Critical pressure ratio, [703](#)
 Critical properties, [353](#), [702](#)
 Critical state, [282](#)
 Critical volume, [282](#)
 Curie's law, [429](#)
 Cut-off ratio, [527](#)
 Cycle, definition, [3](#)
 Cyclic heat engine, [112](#)
- Dalton's law of partial pressures, [360](#)
 Dead state, [229](#)
 Dearthorator, [479](#)
 De Broglie equation, [776](#)
 Debye temperature, [433](#)
 Debye's T^3 law, [818](#), [433](#)
 Degeneracy, [784](#)
 Degradation, [234](#)
 Degradation of energy, [221](#)
 Degree of reaction, [644](#)
 Degree of saturation, [619](#)
 Degree of subcooling, [584](#)
 Degree of superheat, [584](#)
 Dehumidification, [624](#)
 Density, [12](#)
 Dew point temperature, [618](#)
 Diabatic flow, [715](#)
 Diathermic wall, [51](#)

- Diesel cycle, 527
Dieterici equation, 349
Diffusor, 700
Dimensional analysis, 739, 741
Dimensional velocity, 704
Directional law, 182
Disorder, 182
Displacement work, 39
Dissipation, 234
Dissipative effects, 123
Distribution of free paths, 898
Dittus-Boelter equation, 739
Dry air, 517
Dry bulb temperature, 619
Dry compression, 580
Dry ice, 600
Dryness fraction, 29
Dual cycle, 530
Dufour effect, 829
Dulong-Petit law, 885
- Effectiveness, 538, 747
Effectiveness-NTU method, 746
Efficiency,
 boiler, 491
 brake, 491
 carnot, 126, 135
 compressor, 539
 fin, 733
 generator, 491
 internal, 490
 isentropic, 464
 isothermal, 346
 mechanical, 491
 overall, 492
 propulsive, 549
 pump, 464
 second law, 240
 turbine, 464, 539
 volumetric, 346, 585
Einstein temperature, 818
Electrical calorimeter, 301
Electrical conductivity, 908
Electrical resistance thermometer, 30
Electrical work, 44
Electron gas, 806
Emissivity, 755
Endothermic reaction, 650
- Energy, 66
 available, 214
 high grade, 214
 internal, 68
 low grade, 214
 kinetic, 67
 potential, 67
 quality of, 219
 unavailable, 217
Energy balance, 237
Energy level, 774
Energy cascading, 245
Energy distribution function, 880
Energy equation, 402
Energy interaction, 37
Energy modes, 67
Energy reservoirs, 114
Engine indicator, 37
Enthalpy, 70
 of air-water vapour mixture, 621
 of combustion, 663
 of formation, 660
 of gas mixtures, 359, 362
 of ideal gas, 351
 of transfer, 847
Entropy, 155
 change, 335
 absolute, 183
 flow, 827
 generation, 173
 increase, 163
 of gas mixture, 359, 362
 of ideal gas, 335
 principle, 163
 transfer, 171
Entropy and direction, 182
Entropy and disorder, 182
Entropy and information, 183
Entropy of transfer, 838
Entropy generation, 832, 833, 836
Entropy generation number, 237
Environment, 2
Equations of state, 328, 349
 Beattie-Bridgeman, 350
 Benedict-Webb-Rubén, 359
 Berthelot, 349
 Dieterici, 349
 ideal gas, 27, 331

- Redlich-Kwong, [349](#)
 Saha-Bose, [349](#)
 van der Waals, [349](#)
 virial, [350](#)
- Equilibrium, [4](#)
 chemical, [4](#)
 criteria for local, [426](#)
 mechanical, [4](#)
 metastable, [425](#)
 neutral, [425](#)
 phase, [422](#)
 reaction, [647](#)
 stable, [424](#)
 thermal, [5](#)
 thermodynamic, [4](#)
 unstable, [425](#)
- Equilibrium constant, [648](#)
 Equipartition of energy, [802](#)
 Ericsson cycle, [523](#)
 Error function, [879](#)
 Euler equation, [91](#)
 Evaporative cooling, [628](#)
 Evaporator, [585](#)
 Exact differential, [396](#)
 Exergy, [220](#)
 Exergy analysis of vapour power cycles, [479](#)
 Exergy balance, [237](#)
 Exothermic reaction, [650](#)
 Expander, [597](#)
 Expansion ratio, [529](#)
 Expansion valve, [380](#)
 Expectation energy, [187](#)
 Extensive property, [3](#)
 External irreversibility, [138](#)
- Fanno line, [709](#)
 Feed water heaters, [477](#)
 closed, [478](#)
 open, [479](#)
 Fermi-Dirac statistics, [794](#)
 First law of thermodynamics, [63](#)
 for a closed system, [65](#)
 for a cycle, [64](#)
 for a steady flow system, [82](#)
 for reactive system, [661](#)
 Finns, [733](#)
 Fixed points of thermometry, [32](#)
- Flash intercooler, [344](#), [588](#)
 Floating node, [775](#)
 Flow work, [46](#)
 Foldback isotherm, [416](#)
 Force of cohesion, [349](#)
 Forced convection, [739](#)
 Fourier's law, [727](#)
 Fourier number, [735](#)
 Fourth law of thermodynamics, [836](#)
 Fowler-Guggenheim's statement, [436](#)
 Free convection, [741](#)
 Free energy change, [653](#)
 Free expansion, [49](#), [741](#)
 Free shaft turbine, [547](#)
 Fuel cells, [670](#)
 Fugacity, [656](#)
 Fusion curve, [410](#), [411](#)
- Gas compression, [343](#)
 Gas constant, [331](#)
 characteristic, [331](#)
 universal, [329](#)
 for gas mixtures, [361](#)
 Gas cycle refrigeration, [596](#)
 Gas mixtures, [359](#)
 Gas power cycles, [521](#)
 Gas tables, [708](#)
 Gas thermometers, [28](#)
 Gas turbine plant, [534](#)
 Generalized compressibility chart, [354](#),
 [355](#), [356](#)
 Generator, [591](#)
 Generator efficiency, [491](#)
 Gibbs-Duhem equation, [419](#)
 Gibbs entropy equation, [418](#)
 Gibbs function, [233](#)
 change, [653](#)
 of formation, [666](#)
 of mixers, [365](#)
 Gibbs phase rule, [422](#)
 Gibbs theorem, [362](#)
 Gouy-Stodola theorem, [234](#)
 Grashof number, [742](#)
 Grassmann diagram, [236](#)
 Gray body, [753](#)
- Harmonic oscillator, [786](#)
 Heat, [51](#)

- energy transfer as, 52
 - latent, 53
 - of reaction, 648
 - of solution, 592
 - of transfer, 848
 - specific, 52, 69
- Heat capacity, 53
- at constant pressure, 70
 - at constant volume, 69
 - ratio, 747
 - of reacting gases, 658
- Heat conduction, 726
- Heat engine, 112
- Heat exchanger, 742, 354, 355, 356
- Heat pump, 175, 95
- Heat rate, 462
- Heat transfer coefficient, 736
- Heating and humidification, 627
- Heating value,
 - higher and lower, 664
- Heisenberg's uncertainty principle, 777
- Helmholtz function, 232
- Heterogeneous system, 4
- History of thermodynamics, 13
- Homogenous system, 4
- Hot air engines, 524
- Humidification, 626
- Humidity ratio, 618
- Ice point, 26
- Ideal gas, 331
 - enthalpy, 332
 - entropy, 335
 - internal energy, 332
 - mixtures, 359
 - properties, 330
 - specific heats, 332, 335
 - temperature scale, 30
- Ideal regenerative cycle, 470
- Ideal working fluid, 481
- Impulse function, 710
- Indicated power, 44
- Indicator diagram, 42
- Inequality of Clausius, 159
- Indexical differentials, 396
- Information theory, 183
- Intensive property, 3
- Intercooling, 344
- Internal efficiency, 490
- Internal energy, 68
 - of gas mixtures, 359
 - of combustion, 663
- International temperature scale, 32
- Inversion curve, 406
- Inversion temperature, 408
- Ionization, 651
- Irradiation, 751
- Irreversible process, 121
- Irreversible thermodynamics, 826
- Irreversibility, 121
 - causes of, 121
 - chemical, 5, 137
 - external, 138
 - internal, 137
 - mechanical, 5, 138
 - thermal, 5, 138
- Isenthalpes, 406
- Isentropic efficiency, 464
- Isentropic flow, 700
- Isentropic process, 174
- Isolated system, 2
- Isothermal compressibility, 401
- Isothermal dissipation of work, 169
- Isothermal efficiency, 346
- Isothermal process, 339
- Jaynes' formalism, 187
- Jet propulsion, 548
- Joule-Kelvin coefficient, 406
- Joule-Kelvin effect, 405
- Joule-Kelvin expansion, 407
- Joule's law, 333
- Keenan function, 226
- Kelvin-Planck statement, 115
- Kelvin temperature scale, 133
- Kinematic viscosity, 738
- Kinetic theory of gases, 860
- Kirchhoff's law, 749
- Knudsen gas, 484
- Laminar flow, 738
- Latent heats, 53,
 - fusion, 410
 - sublimation, 412
 - vaporization, 410

- Latent heat load, [623](#)
 Law of corresponding states, [354](#)
 Law of degradation of energy, [221](#)
 Law of mass action, [648](#)
 Law of probability, [797](#)
 Limited pressure, cycle, [530](#)
 Linde-Hampson cycle, [598](#)
 Liquefaction of gases, [598](#)
 Liquid yield, [599](#)
 Lithium bromide-water
 absorption cycle, [593](#)
 Log-mean temperature difference,
 [744, 746](#)
 Lost work, [174](#)

 Mach number, [698](#)
 Macroscopic energy mode, [67](#)
 Macroscopic view point, [1](#)
 Macrostate, [788](#)
 Maximum work, [168, 222](#)
 Maxwell's equations [398](#)
 Maxwell-Boltzmann statistics, [788](#)
 Maxwell-Boltzmann distribution
 function, [791](#)
 Maxwell-Boltzmann velocity
 distribution, [870](#)
 Mean effective pressure, [43](#)
 Mean free path, [897](#)
 Mean temperature of heat
 addition, [465](#)
 Mechanical efficiency, [491](#)
 Mechanical energy reservoir, [114](#)
 Mechanical equilibrium, [4](#)
 Mechanical irreversibility, [138](#)
 Mechanical stability, [428](#)
 Metallurgical limit, [466](#)
 Metastable equilibrium, [425](#)
 Microscopic energy mode, [67, 68](#)
 Microscopic viewpoint [1](#)
 Microstate, [788](#)
 Minimum prejudice principle, [186](#)
 Mixed cycle, [530](#)
 Mixture of gases, [359](#)
 Mixtures of variable composition, [417](#)
 Molal chemical potential, [417](#)
 Mole, [328](#)
 Mole fraction [360](#)
 Molecular model, [860](#)

 Molecular collisions on stationary
 wall, [867](#)
 Mollier diagram, [288, 297](#)
 Monatomic ideal gas, [799](#)
 Multistage compression, [344](#)
 Multistage vapour compression
 cycle, [586](#)

 Natural, convection, [736, 741](#)
 Nernst-Simon statement of third
 law, [431](#)
 Nernst's equation, [651](#)
 Neutral equilibrium, [425](#)
 Newton's law of cooling, [737](#)
 Newton's law of viscosity, [829, 903](#)
 Normal boiling point, [283](#)
 Normal shocks, [708](#)
 Nozzle, [86, 700](#)
 converging-diverging, [700](#)
 subsonic, [701](#)
 supersonic, [702](#)
 throat, [700](#)
 Number of transfer units, [748](#)
 Nusselt number, [742](#)

 Ohm's Law, [837](#)
 One dimensional flow, [700](#)
 Onsager equations, [828](#)
 Onsager reciprocal relation, [829](#)
 Optimum regeneration, [479](#)
 Otto cycle, [524](#)
 Overall efficiency of plant, [492](#)
 Overall heat transfer coefficient, [737](#)
 Ozone depletion potential [586](#)

 Paddle-wheel work, [45, 125](#)
 Parallel flow heat exchanger, [742](#)
 Partial pressure, [360](#)
 Partial volume, [361](#)
 Partition function, [188, 795](#)
 Pascal, [10](#)
 Passout turbine, [488](#)
 Path, [3](#)
 Path function, [40](#)
 Pauli's exclusion principle, [794](#)
 Peltier effect, [842](#)
 Perfect inter cooling, [344](#)
 Perpetual motion machine
 of the first kind, [71](#)

- of the second kind, [116](#)
- Perpetual motion of the third kind, [123](#)
- Phase change of the first order, [409](#)
- Phase equilibrium, [422](#)
- Phase equilibrium diagrams, [283, 288, 290](#)
- Phase rule, [422](#)
- Phase space, [786](#)
- Phenomenological laws, [829](#)
- Photon gas statistics, [804](#)
- Planck's constant, [772](#)
- Planck's law, [750, 806](#)
- Point function, [40](#)
- Polytropic process, [339](#)
- Polytropic specific heat, [342](#)
- Postulatory thermodynamics, [190](#)
- Power, [13](#)
 - brake, [44](#)
 - indicated, [44](#)
- Prandtl number, [739, 742](#)
- Pressure, [9](#)
 - absolute, [10](#)
 - measurement, [11](#)
 - partial, [359](#)
 - reduced, [354](#)
 - stagnation, [698](#)
- Pressure ratio, [343, 536, 540](#)
- Principle of caratheodory, [158](#)
- Principle of increase of entropy, [163](#)
- Principle of equipartition of energy, [802](#)
- Principle of minimum prejudice, [186](#)
- Principle of superposition, [830](#)
- Probability function, [781](#)
- Probability, law of [797](#)
- Probability, thermodynamic, [183, 788](#)
- Process, [3](#)
 - irreversible, [121](#)
 - isentropic, [174, 336](#)
 - isothermal, [339](#)
 - quasi-static, [5](#)
 - reversible, [120](#)
- Process heat, [487](#)
- Property, [3](#)
- Propulsive efficiency, [549](#)
- Propulsive power, [548](#)
- Psychrometer, [620](#)
- Psychrometric chart, [622](#)
- Psychrometric processes, [623](#)
- Pure substance, [7, 279](#)
- Quality, [291](#)
 - measurement, [295](#)
- Quality of energy, [219](#)
- Quantum hypothesis, [772](#)
- Quantum number, [782](#)
- Quantum state, [774](#)
- Quasi-static process, [5](#)
- Radiation, [726](#)
- Radiation pressure, [404](#)
- Radiosity, [751](#)
- Ramjet engine, [551](#)
- Range, [631](#)
- Rankine cycle, [459](#)
 - with regeneration, [472](#)
 - with reheat, [468](#)
- Rayleigh line, [710](#)
- Reaction equilibrium, [647](#)
- Reactive systems, [644](#)
- Reciprocal relation, [586](#)
- Reciprocity theorem, [751](#)
- Rectifier, [592](#)
- Redlich-Kwong equation of state, [349](#)
- Reduced properties, [352](#)
- Reference points in temperature scale, [24, 32](#)
- Reflectivity, [749](#)
- Refrigeration, [578](#)
- Refrigeration cycles, [5](#)
 - absorption, [591](#)
 - gas cycle, [596](#)
 - vapour compression, [580](#)
- Refrigerants, [586](#)
- Refrigerating effect, [581](#)
- Refrigerator, [116](#)
- Regenerative cycle, [472](#)
- Regenerator, [537](#)
 - effectiveness, [538](#)
- Reheat cycle, [468](#)
- Reheat regenerative cycle, [476](#)
- Reheating, [543](#)
- Relative humidity, [618](#)
- Resistance concept, [728](#)
- Reversed Brayton cycle, [596](#)
- Reversed Carnot cycle, [128](#)

- Reversed heat engine cycle, [579](#)
 Reversibility, [120](#)
 conditions [126](#)
 Reversible process, [120](#)
 Reversible work, [167, 272](#)
 Reynolds number, [738, 742](#)
- Saha's equation, [652](#)
 Saha-Bose equation, [349](#)
 Sackur-Tetrode equation of state, [802](#)
 Saturated air, [617](#)
 Saturated solid, [280](#)
 Saturated state, [280](#)
 Saturated vapour, [280](#)
 Saturation dome, [289](#)
 Saturation pressure, [283](#)
 Saturation temperature, [284](#)
 Schrodinger wave equation, [780](#)
 Second law efficiency, [240](#)
 Second law inequality, [159](#)
 Second law of thermodynamics, [115](#)
 Seebeck effect, [839](#)
 Sensible heating or cooling, [623](#)
 Separating and throttling
 calorimeter, [300](#)
 Shaft power, [44](#)
 Shaft work, [45](#)
 Shannon's formula, [185](#)
 Sink, [114](#)
 SI unit system, [8](#)
 Solid ice, [600](#)
 Sonic velocity, [697](#)
 Soret effect, [829](#)
 Source, [114](#)
 Spark ignition engine, [525](#)
 Specific heats, [69](#)
 of gases, [332](#)
 at constant pressure, [70](#)
 at constant volume, [69](#)
 polytropic, [342](#)
 of solids, [816, 884](#)
 Specific humidity [618](#)
 Specific volume, [12](#)
 of mixture, [361](#)
 Stability, conditions of, [425](#)
 Stable equilibrium, [424](#)
 Stagnation pressure, [698](#)
 Stagnation properties, [698](#)
 Stagnation temperature, [698](#)
 States, [3](#)
 changes of, [3](#)
 Statistical formalism, [186](#)
 Statistics of electron gas, [806](#)
 Statistics of photon gas, [804](#)
 Steady flow process, [82](#)
 Steady flow energy equation, [85](#)
 Steady state, [82](#)
 Steam point, [26](#)
 Steam power plant, [459](#)
 Steam rule, [461](#)
 Steam tables, [293](#)
 Stefan-Boltzmann law, [750, 806](#)
 Stirling cycle, [522](#)
 Stirling's approximation, [790](#)
 Stirring work, [45](#)
 Stoichiometric air, [659](#)
 Stoichiometric coefficients, [644](#)
 Stored energy, [65, 67](#)
 Space resistance, [754](#)
 Steamline, [738](#)
 Strength of shock, [714](#)
 Sub cooling, [584](#)
 Sublimation, curve, [412](#)
 Subsonic flow, [701](#)
 Suction line heat exchanger, [585](#)
 Superheat, [584](#)
 Supersonic flow, [701](#)
 Supplementary firing, [553](#)
 Surface resistance, [753](#)
 Surroundings, [2](#)
 System, [2](#)
 closed, [2](#)
 isolated, [2](#)
 open, [2](#)
- Tds equations, [399](#)
 Terminal temperature difference, [478](#)
 Temperature, [24](#)
 absolute, [135, 866](#)
 adiabatic saturation, [620](#)
 Celsius, [30](#)
 critical, [282, 702](#)
 dew point, [618](#)
 dry bulb, [619](#)
 ideal gas, [30](#)
 Kelvin, [133](#)

- measurement, [24](#), [28](#), [30](#), [31](#)
- reduced, [352](#)
- Thermal conductivity, [904](#), [727](#)
- Thermal stability, [428](#)
- Thermal equilibrium, [5](#)
- Thermodynamic scale, [131](#)
- Thermoelectric power, [841](#)
- Thermomechanical effect, [847](#)
 - phenomena, [846](#)
- Thermometers, [25](#)
- Thermometric property, [24](#)
- Thermofmolecular pressure difference, [848](#)
- Third law of thermodynamics, [135](#), [428](#)
- Thomson effect, [843](#)
- Thomson coefficient, [844](#)
- Thomson relations, [845](#)
- Throttling calorimeter, [298](#), [300](#), [301](#)
- Tonne of refrigeration, [583](#)
- Topping cycle, [485](#), [486](#)
- Torque, [44](#)
- Transmissivity, [749](#)
- Transport properties, [901](#)
- Triple point, [26](#), [282](#)
- Trouton's rule, [411](#)
- Turbofan engine, [550](#)
- Turboprop engine, [551](#)
- Turbulent flow, [738](#)

- Unavailable energy, [217](#)
- Uncertainty, [183](#)

- Units and dimensions, [8](#)
- Universal gas constant, [329](#)
- Universe, [163](#)
- Unsaturated air, [617](#)
- Unstable equilibrium, [425](#)
- Useful work, [227](#)

- Vacuum, [10](#)
- Van der Waals equation, [329](#), [869](#)
- Van't Hoff equation [649](#)
- Vaporization curve, [285](#), [412](#)
- Vapour compression cycle, [580](#)
- Vapour power cycle, [457](#)
- Vapour pressure, [283](#), [411](#)
- Variable flow process, [91](#)
- View factor, [750](#)
- Virial coefficients, [350](#)
- Virial expansion, [350](#)
- Viscosity, [738](#)
- Volume, critical, [282](#)
 - reduced, [352](#)
 - specific, [12](#)
- Volume expansivity, [400](#)
- Volumetric efficiency, [346](#), [585](#)

- Watt, [13](#),
- Wave-particle duality, [775](#)
- Wet bulb temperature, [619](#)
- Wet compression, [580](#)
- Work transfer, [37](#)
 - various forms, [39](#), [44](#)

- Zeroth law of thermodynamics, [24](#)

BASIC AND APPLIED THERMODYNAMICS

This text is the only book to present the Macroscopic [Classical] and Microscopic [Statistical] Thermodynamics in a single volume. The first eleven chapters contribute to the basic theories of Thermodynamics beginning with the first chapter on Introduction that provides a historical background of the subject. The next seven chapters provide applications of these theories. The Microscopic concepts of thermodynamics are furnished in the last four chapters.

Salient Features

- Both Microscopic and Macroscopic approaches presented to facilitate clear understanding of the thermodynamic concepts, properties and processes.
- Outline of Information Theory as applied to thermodynamics presented in the chapter on Entropy.
- Special treatise on the Third Law of Thermodynamics.
- Coverage of topics on exergy balance, chemical exergy and fuel cells.
- Enhanced response to power refrigeration cycle analysis and heat transfer concepts is included.
- Information on turbojet and turboprop engines under the coverage on Jet Propulsion.
- Up-to-date property tables and charts including those of non-CFC refrigerants provided as appendices.
- Pedagogy includes

- ▶ 196 solved examples
- ▶ 592 exercise problems with answers
- ▶ 518 illustrations
- ▶ 664 review questions

Premier12

Tata McGraw-Hill

A Division of The McGraw-Hill Companies



Visit us at: www.tatamcgrawhill.com

ISBN 0-07-047338-2



9 780070 473386