



20

Cams

Features

1. Introduction.
2. Classification of Followers.
3. Classification of Cams.
4. Terms used in Radial cams.
5. Motion of the Follower.
6. Displacement, Velocity and Acceleration Diagrams when the Follower Moves with Uniform Velocity.
7. Displacement, Velocity and Acceleration Diagrams when the Follower Moves with Simple Harmonic Motion.
8. Displacement, Velocity and Acceleration Diagrams when the Follower Moves with Uniform Acceleration and Retardation.
9. Displacement, Velocity and Acceleration Diagrams when the Follower Moves with Cycloidal Motion.
10. Construction of Cam Profiles.
11. Cams with Specified Contours.
12. Tangent Cam with Reciprocating Roller Follower.
13. Circular Arc Cam with Flat-faced Follower.

20.1. Introduction

A **cam** is a rotating machine element which gives reciprocating or oscillating motion to another element known as **follower**. The cam and the follower have a line contact and constitute a higher pair. The cams are usually rotated at uniform speed by a shaft, but the follower motion is predetermined and will be according to the shape of the cam. The cam and follower is one of the simplest as well as one of the most important mechanisms found in modern machinery today. The cams are widely used for operating the inlet and exhaust valves of internal combustion engines, automatic attachment of machineries, paper cutting machines, spinning and weaving textile machineries, feed mechanism of automatic lathes etc.

20.2. Classification of Followers

The followers may be classified as discussed below :

1. According to the surface in contact. The followers, according to the surface in contact, are as follows :

- (a) **Knife edge follower.** When the contacting end of the follower has a sharp knife edge, it is called a knife edge follower, as shown in Fig. 20.1 (a). The sliding motion takes place between the contacting surfaces (*i.e.* the knife edge and the cam surface). It is seldom used in practice because the small area of contacting surface results in excessive wear. In knife edge followers, a considerable side thrust exists between the follower and the guide.

- (b) **Roller follower.** When the contacting end of the follower is a roller, it is called a roller follower, as shown in Fig. 20.1 (b). Since the rolling motion takes place between the contacting surfaces (*i.e.* the roller and the cam), therefore the rate of wear is greatly reduced. In roller followers also the side thrust exists between the follower and the guide. The roller followers are extensively used where more space is available such as in stationary gas and oil engines and aircraft engines.
- (c) **Flat faced or mushroom follower.** When the contacting end of the follower is a perfectly flat face, it is called a flat-faced follower, as shown in Fig. 20.1 (c). It may be noted that the side thrust between the follower and the guide is much reduced in case of flat faced followers. The only side thrust is due to friction between the contact surfaces of the follower and the cam. The relative motion between these surfaces is largely of sliding nature but wear may be reduced by off-setting the axis of the follower, as shown in Fig. 20.1 (f) so that when the cam rotates, the follower also rotates about its own axis. The flat faced followers are generally used where space is limited such as in cams which operate the valves of automobile engines.

Note : When the flat faced follower is circular, it is then called a mushroom follower.

- (d) **Spherical faced follower.** When the contacting end of the follower is of spherical shape, it is called a spherical faced follower, as shown in Fig. 20.1 (d). It may be noted that when a flat-faced follower is used in automobile engines, high surface stresses are produced. In order to minimise these stresses, the flat end of the follower is machined to a spherical shape.

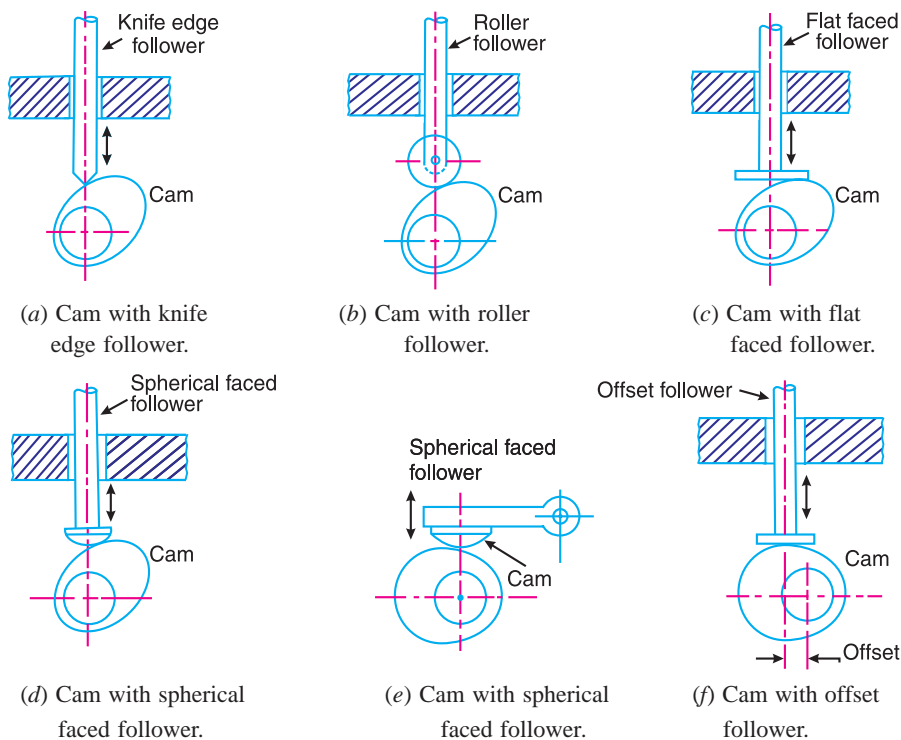

Fig. 20.1. Classification of followers.

2. According to the motion of the follower. The followers, according to its motion, are of the following two types:

(a) **Reciprocating or translating follower.** When the follower reciprocates in guides as the cam rotates uniformly, it is known as reciprocating or translating follower. The followers as shown in Fig. 20.1 (a) to (d) are all reciprocating or translating followers.

(b) **Oscillating or rotating follower.** When the uniform rotary motion of the cam is converted into predetermined oscillatory motion of the follower, it is called oscillating or rotating follower. The follower, as shown in Fig 20.1 (e), is an oscillating or rotating follower.

3. **According to the path of motion of the follower.** The followers, according to its path of motion, are of the following two types:

(a) **Radial follower.** When the motion of the follower is along an axis passing through the centre of the cam, it is known as radial follower. The followers, as shown in Fig. 20.1 (a) to (e), are all radial followers.

(b) **Off-set follower.** When the motion of the follower is along an axis away from the axis of the cam centre, it is called off-set follower. The follower, as shown in Fig. 20.1 (f), is an off-set follower.

Note : In all cases, the follower must be constrained to follow the cam. This may be done by springs, gravity or hydraulic means. In some types of cams, the follower may ride in a groove.

20.3. Classification of Cams

Though the cams may be classified in many ways, yet the following two types are important from the subject point of view :

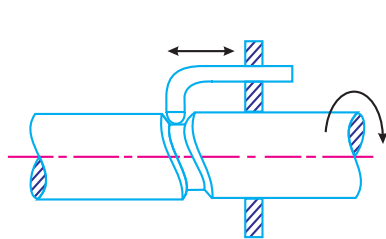

(a) Cylindrical cam with reciprocating follower.

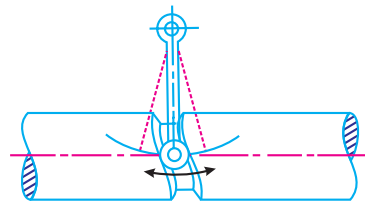

(b) Cylindrical cam with oscillating follower.

Fig. 20.2. Cylindrical cam.

1. **Radial or disc cam.** In radial cams, the follower reciprocates or oscillates in a direction perpendicular to the cam axis. The cams as shown in Fig. 20.1 are all radial cams.

2. **Cylindrical cam.** In cylindrical cams, the follower reciprocates or oscillates in a direction parallel to the cam axis. The follower rides in a groove at its cylindrical surface. A cylindrical grooved cam with a reciprocating and an oscillating follower is shown in Fig. 20.2 (a) and (b) respectively.

Note : In actual practice, radial cams are widely used. Therefore our discussion will be only confined to radial cams.



In IC engines, cams are widely used to operate valves.

20.4. Terms Used in Radial Cams

Fig. 20.3 shows a radial cam with reciprocating roller follower. The following terms are important in order to draw the cam profile.

1. Base circle. It is the smallest circle that can be drawn to the cam profile.

2. Trace point. It is a reference point on the follower and is used to generate the *pitch curve*. In case of knife edge follower, the knife edge represents the trace point and the pitch curve corresponds to the cam profile. In a roller follower, the centre of the roller represents the trace point.

3. Pressure angle. It is the angle between the direction of the follower motion and a normal to the pitch curve. This angle is very important in designing a cam profile. If the pressure angle is too large, a reciprocating follower will jam in its bearings.

4. Pitch point. It is a point on the pitch curve having the maximum pressure angle.

5. Pitch circle. It is a circle drawn from the centre of the cam through the pitch points.

6. Pitch curve. It is the curve generated by the trace point as the follower moves relative to the cam. For a knife edge follower, the pitch curve and the cam profile are same whereas for a roller follower, they are separated by the radius of the roller.

7. Prime circle. It is the smallest circle that can be drawn from the centre of the cam and tangent to the pitch curve. For a knife edge and a flat face follower, the prime circle and the base circle are identical. For a roller follower, the prime circle is larger than the base circle by the radius of the roller.

8. Lift or stroke. It is the maximum travel of the follower from its lowest position to the topmost position.

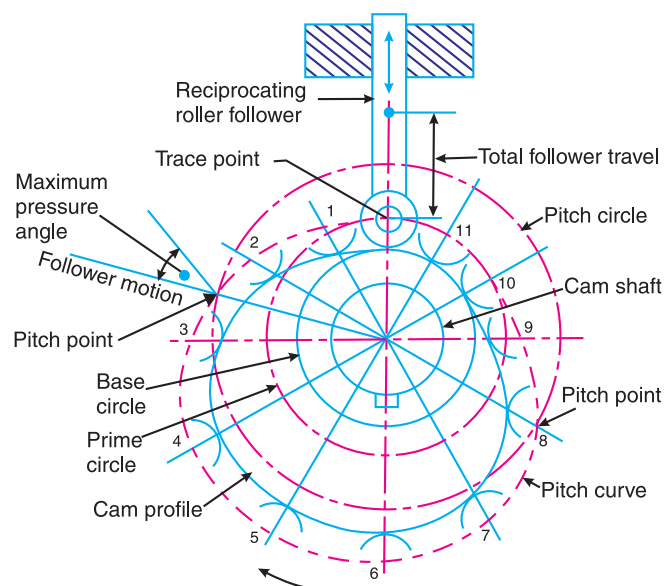

Fig. 20.3. Terms used in radial cams.

20.5. Motion of the Follower

The follower, during its travel, may have one of the following motions.

1. Uniform velocity, **2.** Simple harmonic motion, **3.** Uniform acceleration and retardation, and **4.** Cycloidal motion.

We shall now discuss the displacement, velocity and acceleration diagrams for the cam when the follower moves with the above mentioned motions.

20.6. Displacement, Velocity and Acceleration Diagrams when the Follower Moves with Uniform Velocity

The displacement, velocity and acceleration diagrams when a knife-edged follower moves with uniform velocity are shown in Fig. 20.4 (a), (b) and (c) respectively. The abscissa (base) represents the time (*i.e.* the number of seconds required for the cam to complete one revolution) or it may represent the angular displacement of the cam in degrees. The ordinate represents the displacement, or velocity or acceleration of the follower.

Since the follower moves with uniform velocity during its rise and return stroke, therefore the slope of the displacement curves must be constant. In other words, AB_1 and C_1D must be straight lines. A little consideration will show that the follower remains at rest during part of the cam rotation. The periods during which the follower remains at rest are known as **dwell periods**, as shown by lines B_1C_1 and DE in Fig. 20.4 (a). From Fig. 20.4 (c), we see that the acceleration or retardation of the follower at the beginning and at the end of each stroke is infinite. This is due to the fact that the follower is required to start from rest and has to gain a velocity within no time. This is only possible if the acceleration or retardation at the beginning and at the end of each stroke is infinite. These conditions are however, impracticable.

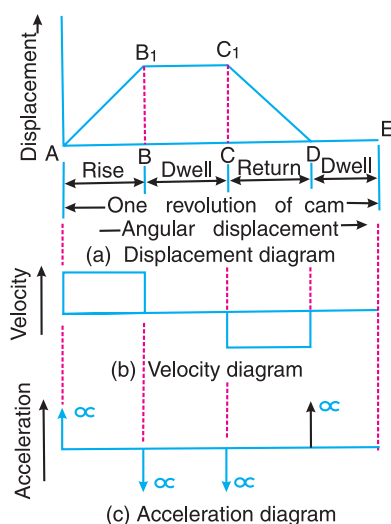

Fig. 20.4. Displacement, velocity and acceleration diagrams when the follower moves with uniform velocity.

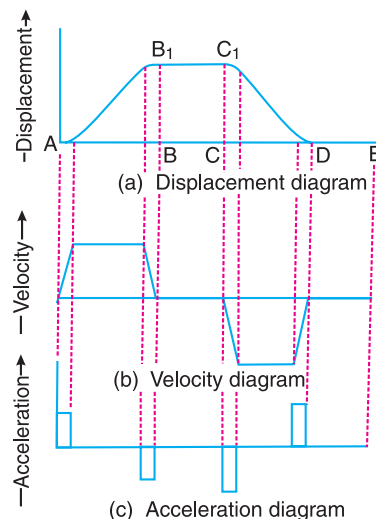

Fig. 20.5. Modified displacement, velocity and acceleration diagrams when the follower moves with uniform velocity.

In order to have the acceleration and retardation within the finite limits, it is necessary to modify the conditions which govern the motion of the follower. This may be done by rounding off the sharp corners of the displacement diagram at the beginning and at the end of each stroke, as shown in Fig. 20.5 (a). By doing so, the velocity of the follower increases gradually to its maximum value at the beginning of each stroke and decreases gradually to zero at the end of each stroke as shown in Fig. 20.5 (b). The modified



Camshaft of an IC engine.

displacement, velocity and acceleration diagrams are shown in Fig. 20.5. The round corners of the displacement diagram are usually parabolic curves because the parabolic motion results in a very low acceleration of the follower for a given stroke and cam speed.

20.7. Displacement, Velocity and Acceleration Diagrams when the Follower Moves with Simple Harmonic Motion

The displacement, velocity and acceleration diagrams when the follower moves with simple harmonic motion are shown in Fig. 20.6 (a), (b) and (c) respectively. The displacement diagram is drawn as follows :

1. Draw a semi-circle on the follower stroke as diameter.
2. Divide the semi-circle into any number of even equal parts (say eight).
3. Divide the angular displacements of the cam during out stroke and return stroke into the same number of equal parts.
4. The displacement diagram is obtained by projecting the points as shown in Fig. 20.6 (a).

The velocity and acceleration diagrams are shown in Fig. 20.6 (b) and (c) respectively. Since the follower moves with a simple harmonic motion, therefore velocity diagram consists of a sine curve and the acceleration diagram is a cosine curve. We see from Fig. 20.6 (b) that the velocity of the follower is zero at the beginning and at the end of its stroke and increases gradually to a maximum at mid-stroke. On the other hand, the acceleration of the follower is maximum at the beginning and at the ends of the stroke and diminishes to zero at mid-stroke.

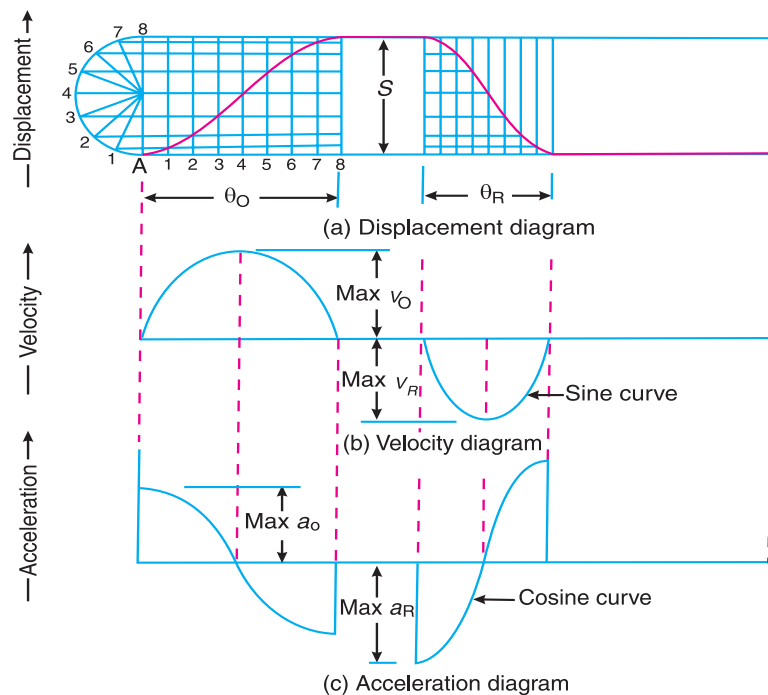

Fig. 20.6. Displacement, velocity and acceleration diagrams when the follower moves with simple harmonic motion.

- Let S = Stroke of the follower,
 θ_O and θ_R = Angular displacement of the cam during out stroke and return stroke of the follower respectively, in radians, and
 ω = Angular velocity of the cam in rad/s.

780 • Theory of Machines

∴ Time required for the out stroke of the follower in seconds,

$$t_O = \theta_O / \omega$$

Consider a point P moving at a uniform speed ω_P radians per sec round the circumference of a circle with the stroke S as diameter, as shown in Fig. 20.7. The point P' (which is the projection of a point P on the diameter) executes a simple harmonic motion as the point P rotates. The motion of the follower is similar to that of point P' .

∴ Peripheral speed of the point P' ,

$$v_P = \frac{\pi S}{2} \times \frac{1}{t_O} = \frac{\pi S}{2} \times \frac{\omega}{\theta_O}$$

and maximum velocity of the follower on the outstroke,

$$v_O = v_P = \frac{\pi S}{2} \times \frac{\omega}{\theta_O} = \frac{\pi \omega S}{2 \theta_O}$$

We know that the centripetal acceleration of the point P ,

$$a_P = \frac{(v_P)^2}{OP} = \left(\frac{\pi \omega S}{2 \theta_O} \right)^2 \times \frac{2}{S} = \frac{\pi^2 \omega^2 S}{2 (\theta_O)^2}$$

∴ Maximum acceleration of the follower on the outstroke,

$$a_O = a_P = \frac{\pi^2 \omega^2 S}{2 (\theta_O)^2}$$

Similarly, maximum velocity of the follower on the return stroke,

$$v_R = \frac{\pi \omega S}{2 \theta_R}$$

and maximum acceleration of the follower on the return stroke,

$$a_R = \frac{\pi^2 \omega^2 S}{2 (\theta_R)^2}$$

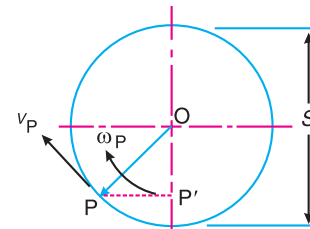

Fig. 20.7. Motion of a point.

20.8. Displacement, Velocity and Acceleration Diagrams when the Follower Moves with Uniform Acceleration and Retardation

The displacement, velocity and acceleration diagrams when the follower moves with uniform acceleration and retardation are shown in Fig. 20.8 (a), (b) and (c) respectively. We see that the displacement diagram consists of a parabolic curve and may be drawn as discussed below :

1. Divide the angular displacement of the cam during outstroke (θ_O) into any even number of equal parts (say eight) and draw vertical lines through these points as shown in Fig. 20.8 (a).
2. Divide the stroke of the follower (S) into the same number of equal even parts.
3. Join Aa to intersect the vertical line through point 1 at B . Similarly, obtain the other points C, D etc. as shown in Fig. 20.8 (a). Now join these points to obtain the parabolic curve for the out stroke of the follower.
4. In the similar way as discussed above, the displacement diagram for the follower during return stroke may be drawn.

Since the acceleration and retardation are uniform, therefore the velocity varies directly with the time. The velocity diagram is shown in Fig. 20.8 (b).

Let S = Stroke of the follower,

θ_O and θ_R = Angular displacement of the cam during out stroke and return stroke of the follower respectively, and

ω = Angular velocity of the cam.

We know that time required for the follower during outstroke,

$$t_O = \theta_O / \omega$$

and time required for the follower during return stroke,

$$t_R = \theta_R / \omega$$

Mean velocity of the follower during outstroke

$$= S/t_O$$

and mean velocity of the follower during return stroke

$$= S/t_R$$

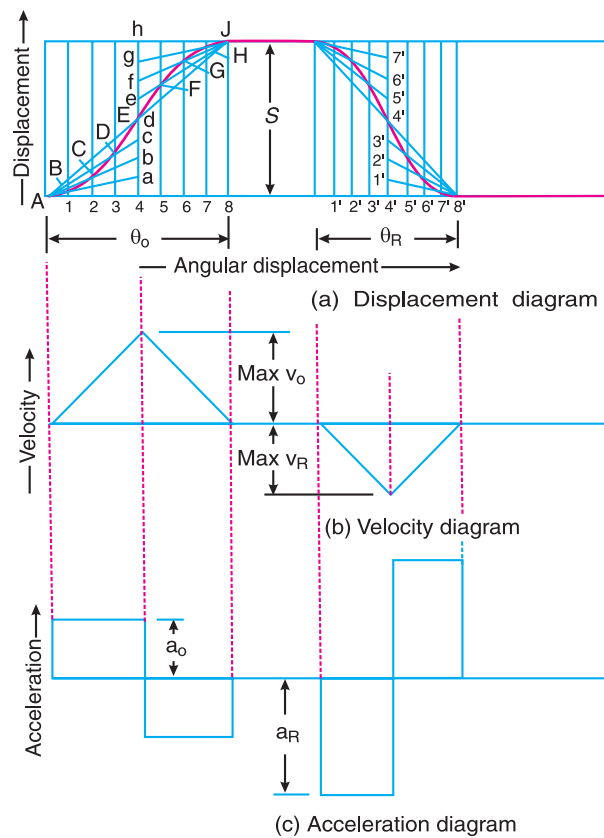

Fig. 20.8. Displacement, velocity and acceleration diagrams when the follower moves with uniform acceleration and retardation.

Since the maximum velocity of follower is equal to twice the mean velocity, therefore maximum velocity of the follower during outstroke,

$$v_O = \frac{2S}{t_O} = \frac{2\omega S}{\theta_O}$$

Similarly, maximum velocity of the follower during return stroke,

$$v_R = \frac{2\omega S}{\theta_R}$$

782 • Theory of Machines

We see from the acceleration diagram, as shown in Fig. 20.8 (c), that during first half of the outstroke there is uniform acceleration and during the second half of the out stroke there is uniform retardation. Thus, the maximum velocity of the follower is reached after the time $t_O/2$ (during out stroke) and $t_R/2$ (during return stroke).

∴ Maximum acceleration of the follower during outstroke,

$$a_O = \frac{v_O}{t_O/2} = \frac{2 \times 2 \omega \cdot S}{t_O \cdot \theta_O} = \frac{4 \omega^2 \cdot S}{(\theta_O)^2} \quad \dots (\because t_O = \theta_O / \omega)$$

Similarly, maximum acceleration of the follower during return stroke,

$$a_R = \frac{4 \omega^2 \cdot S}{(\theta_R)^2}$$

20.9. Displacement, Velocity and Acceleration Diagrams when the Follower Moves with Cycloidal Motion

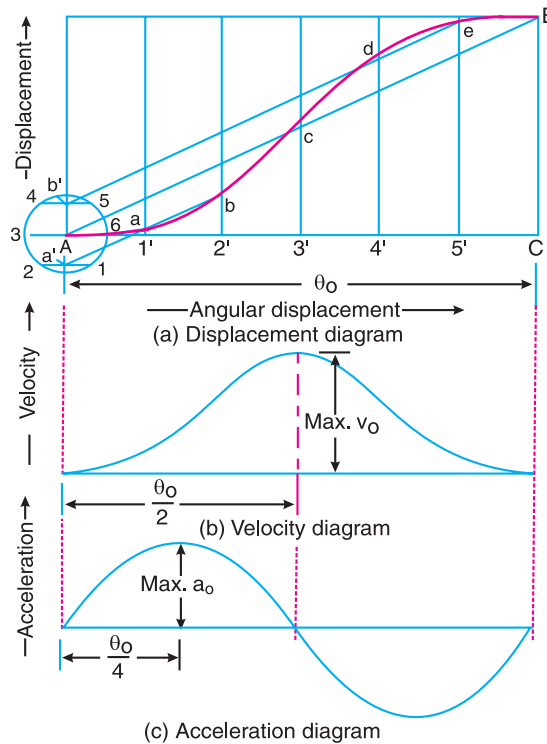

Fig. 20.9. Displacement, velocity and acceleration diagrams when the follower moves with cycloidal motion.

The displacement, velocity and acceleration diagrams when the follower moves with cycloidal motion are shown in Fig. 20.9 (a), (b) and (c) respectively. We know that cycloid is a curve traced by a point on a circle when the circle rolls without slipping on a straight line.

In case of cams, this straight line is a stroke of the follower which is translating and the circumference of the rolling circle is equal to the stroke (S) of the follower. Therefore the radius of

the rolling circle is $S/2\pi$. The displacement diagram is drawn as discussed below :

1. Draw a circle of radius $S/2\pi$ with A as centre.
2. Divide the circle into any number of equal even parts (say six). Project these points horizontally on the vertical centre line of the circle. These points are shown by a' and b' in Fig. 20.9 (a).
3. Divide the angular displacement of the cam during outstroke into the same number of equal even parts as the circle is divided. Draw vertical lines through these points.
4. Join AB which intersects the vertical line through $3'$ at c . From a' draw a line parallel to AB intersecting the vertical lines through $1'$ and $2'$ at a and b respectively.
5. Similarly, from b' draw a line parallel to AB intersecting the vertical lines through $4'$ and $5'$ at d and e respectively.
6. Join the points $A a b c d e B$ by a smooth curve. This is the required cycloidal curve for the follower during outstroke.



Cams are used in Jet and aircraft engines. The above picture shows an aircraft engine.

Let θ = Angle through which the cam rotates in time t seconds, and
 ω = Angular velocity of the cam.

We know that displacement of the follower after time t seconds,

$$x = S \left[\frac{\theta}{\theta_0} - \frac{1}{2\pi} \sin \left(\frac{2\pi\theta}{\theta_0} \right) \right] \quad \dots (i)$$

\therefore Velocity of the follower after time t seconds,

$$\frac{dx}{dt} = S \left[\frac{1}{\theta_0} \times \frac{d\theta}{dt} - \frac{2\pi}{2\pi\theta_0} \cos \left(\frac{2\pi\theta}{\theta_0} \right) \frac{d\theta}{dt} \right] \quad \dots \text{[Differentiating equation (i)]}$$

$$= \frac{S}{\theta_0} \times \frac{d\theta}{dt} \left[1 - \cos \left(\frac{2\pi\theta}{\theta_0} \right) \right] = \frac{\omega S}{\theta_0} \left[1 - \cos \left(\frac{2\pi\theta}{\theta_0} \right) \right] \quad \dots (ii)$$

784 • Theory of Machines

The velocity is maximum, when

$$\cos\left(\frac{2\pi\theta}{\theta_O}\right) = -1 \quad \text{or} \quad \frac{2\pi\theta}{\theta_O} = \pi \quad \text{or} \quad \theta = \theta_O/2$$

Substituting $\theta = \theta_O/2$ in equation (ii), we have maximum velocity of the follower during outstroke,

$$v_O = \frac{\omega.S}{\theta_O}(1+1) = \frac{2\omega.S}{\theta_O}$$

Similarly, maximum velocity of the follower during return stroke,

$$v_R = \frac{2\omega.S}{\theta_R}$$

Now, acceleration of the follower after time t sec,

$$\frac{d^2x}{dt^2} = \frac{\omega.S}{\theta_O} \left[\frac{2\pi}{\theta_O} \sin\left(\frac{2\pi\theta}{\theta_O}\right) \frac{d\theta}{dt} \right] \quad \dots \text{ [Differentiating equation (ii)]}$$

$$= \frac{2\pi\omega^2.S}{(\theta_O)^2} \sin\left(\frac{2\pi\theta}{\theta_O}\right) \quad \dots \left(\because \frac{d\theta}{dt} = \omega \right) \quad \dots \text{ (iii)}$$

The acceleration is maximum, when

$$\sin\left(\frac{2\pi\theta}{\theta_O}\right) = 1 \quad \text{or} \quad \frac{2\pi\theta}{\theta_O} = \frac{\pi}{2} \quad \text{or} \quad \theta = \theta_O/4$$

Substituting $\theta = \theta_O/4$ in equation (iii), we have maximum acceleration of the follower during outstroke,

$$a_O = \frac{2\pi\omega^2.S}{(\theta_O)^2}$$

Similarly, maximum acceleration of the follower during return stroke,

$$a_R = \frac{2\pi\omega^2.S}{(\theta_R)^2}$$

The velocity and acceleration diagrams are shown in Fig. 20.9 (b) and (c) respectively.

20.10. Construction of Cam Profile for a Radial Cam

In order to draw the cam profile for a radial cam, first of all the displacement diagram for the given motion of the follower is drawn. Then by constructing the follower in its proper position at each angular position, the profile of the working surface of the cam is drawn.

In constructing the cam profile, the principle of kinematic inversion is used, *i.e.* the cam is imagined to be stationary and the follower is allowed to rotate in the **opposite direction** to the **cam rotation**.

The construction of cam profiles for different types of follower with different types of motions are discussed in the following examples.

Example 20.1. A cam is to give the following motion to a knife-edged follower :

1. Outstroke during 60° of cam rotation ; **2.** Dwell for the next 30° of cam rotation ; **3.** Return stroke during next 60° of cam rotation, and **4.** Dwell for the remaining 210° of cam rotation.

The stroke of the follower is 40 mm and the minimum radius of the cam is 50 mm. The follower moves with uniform velocity during both the outstroke and return strokes. Draw the profile of the cam when (a) the axis of the follower passes through the axis of the cam shaft, and (b) the axis of the follower is offset by 20 mm from the axis of the cam shaft.

Construction

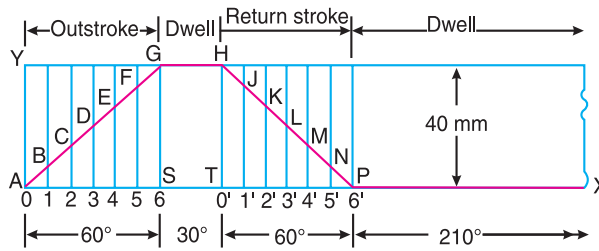

Fig. 20.10

First of all, the displacement diagram, as shown in Fig. 20.10, is drawn as discussed in the following steps :

1. Draw a horizontal line $AX = 360^\circ$ to some suitable scale. On this line, mark $AS = 60^\circ$ to represent outstroke of the follower, $ST = 30^\circ$ to represent dwell, $TP = 60^\circ$ to represent return stroke and $PX = 210^\circ$ to represent dwell.
2. Draw vertical line AY equal to the stroke of the follower (*i.e.* 40 mm) and complete the rectangle as shown in Fig. 20.10.
3. Divide the angular displacement during outstroke and return stroke into any equal number of even parts (say six) and draw vertical lines through each point.
4. Since the follower moves with uniform velocity during outstroke and return stroke, therefore the displacement diagram consists of straight lines. Join AG and HP .
5. The complete displacement diagram is shown by $AGHPX$ in Fig. 20.10.

(a) Profile of the cam when the axis of follower passes through the axis of cam shaft

The profile of the cam when the axis of the follower passes through the axis of the cam shaft, as shown in Fig. 20.11, is drawn as discussed in the following steps :

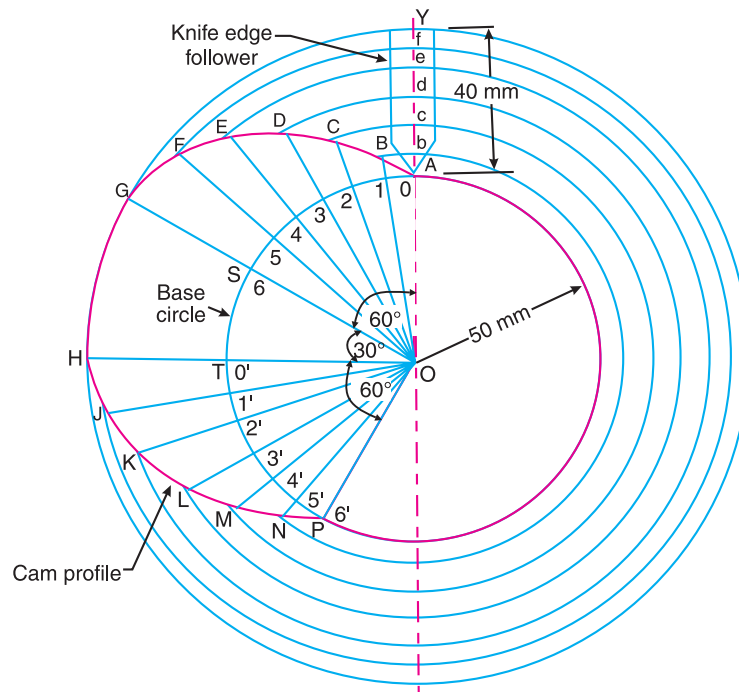

Fig. 20.11

786 • Theory of Machines

1. Draw a base circle with radius equal to the minimum radius of the cam (i.e. 50 mm) with O as centre.
2. Since the axis of the follower passes through the axis of the cam shaft, therefore mark trace point A , as shown in Fig. 20.11.
3. From OA , mark angle $AOS = 60^\circ$ to represent outstroke, angle $SOT = 30^\circ$ to represent dwell and angle $TOP = 60^\circ$ to represent return stroke.
4. Divide the angular displacements during outstroke and return stroke (i.e. angle AOS and angle TOP) into the same number of equal even parts as in displacement diagram.
5. Join the points 1, 2, 3 ...etc. and $0', 1', 2', 3', \dots$ etc. with centre O and produce beyond the base circle as shown in Fig. 20.11.
6. Now set off $1B, 2C, 3D \dots$ etc. and $0'H, 1'J \dots$ etc. from the displacement diagram.
7. Join the points $A, B, C, \dots M, N, P$ with a smooth curve. The curve $AGHPA$ is the complete profile of the cam.

Notes : The points $B, C, D \dots L, M, N$ may also be obtained as follows :

1. Mark $AY = 40$ mm on the axis of the follower, and set of $Ab, Ac, Ad \dots$ etc. equal to the distances $1B, 2C, 3D \dots$ etc. as in displacement diagram.
2. From the centre of the cam O , draw arcs with radii Ob, Oc, Od etc. The arcs intersect the produced lines $O1, O2 \dots$ etc. at $B, C, D \dots L, M, N$.

(b) Profile of the cam when the axis of the follower is offset by 20 mm from the axis of the cam shaft

The profile of the cam when the axis of the follower is offset from the axis of the cam shaft, as shown in Fig. 20.12, is drawn as discussed in the following steps :

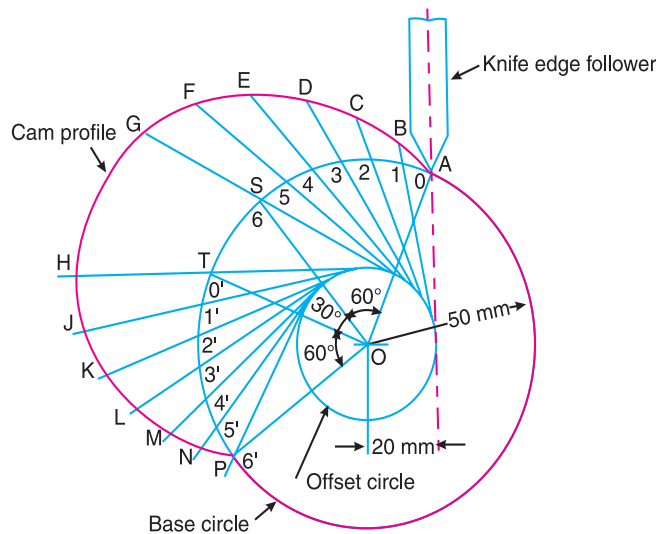

Fig. 20.12

1. Draw a base circle with radius equal to the minimum radius of the cam (i.e. 50 mm) with O as centre.
2. Draw the axis of the follower at a distance of 20 mm from the axis of the cam, which intersects the base circle at A .
3. Join AO and draw an offset circle of radius 20 mm with centre O .
4. From OA , mark angle $AOS = 60^\circ$ to represent outstroke, angle $SOT = 30^\circ$ to represent dwell and angle $TOP = 60^\circ$ to represent return stroke.

5. Divide the angular displacement during outstroke and return stroke (*i.e.* angle AOS and angle TOP) into the same number of equal even parts as in displacement diagram.
6. Now from the points 1, 2, 3 ... etc. and $0', 1', 2', 3' ...$ etc. on the base circle, draw tangents to the offset circle and produce these tangents beyond the base circle as shown in Fig. 20.12.
7. Now set off $1B, 2C, 3D ...$ etc. and $0'H, 1'J ...$ etc. from the displacement diagram.
8. Join the points $A, B, C ... M, N, P$ with a smooth curve. The curve $AGHPA$ is the complete profile of the cam.

Example 20.2. A cam is to be designed for a knife edge follower with the following data :

1. Cam lift = 40 mm during 90° of cam rotation with simple harmonic motion.
2. Dwell for the next 30° .
3. During the next 60° of cam rotation, the follower returns to its original position with simple harmonic motion.
4. Dwell during the remaining 180° .

Draw the profile of the cam when

- (a) the line of stroke of the follower passes through the axis of the cam shaft, and
- (b) the line of stroke is offset 20 mm from the axis of the cam shaft.

The radius of the base circle of the cam is 40 mm. Determine the maximum velocity and acceleration of the follower during its ascent and descent, if the cam rotates at 240 r.p.m.

Solution. Given : $S = 40 \text{ mm} = 0.04 \text{ m}$; $\theta_O = 90^\circ = \pi/2 \text{ rad} = 1.571 \text{ rad}$; $\theta_R = 60^\circ = \pi/3 \text{ rad} = 1.047 \text{ rad}$; $N = 240 \text{ r.p.m.}$

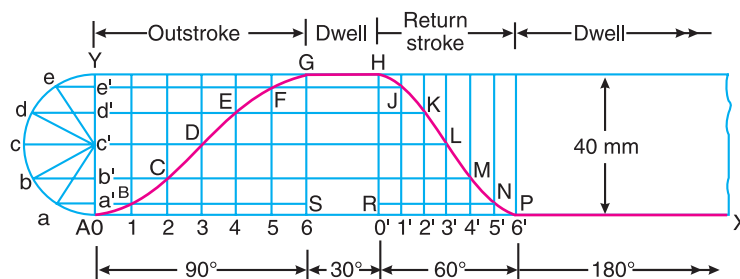

Fig. 20.13

First of all, the displacement diagram, as shown in Fig 20.13, is drawn as discussed in the following steps :

1. Draw horizontal line $AX = 360^\circ$ to some suitable scale. On this line, mark $AS = 90^\circ$ to represent out stroke ; $SR = 30^\circ$ to represent dwell ; $RP = 60^\circ$ to represent return stroke and $PX = 180^\circ$ to represent dwell.
2. Draw vertical line $AY = 40 \text{ mm}$ to represent the cam lift or stroke of the follower and complete the rectangle as shown in Fig. 20.13.
3. Divide the angular displacement during out stroke and return stroke into any equal number of even parts (say six) and draw vertical lines through each point.
4. Since the follower moves with simple harmonic motion, therefore draw a semicircle with AY as diameter and divide into six equal parts.
5. From points $a, b, c ...$ etc. draw horizontal lines intersecting the vertical lines drawn through 1, 2, 3 ... etc. and $0', 1', 2' ...$ etc. at $B, C, D ... M, N, P$.
6. Join the points $A, B, C ...$ etc. with a smooth curve as shown in Fig. 20.13. This is the required displacement diagram.

(a) *Profile of the cam when the line of stroke of the follower passes through the axis of the cam shaft*

The profile of the cam when the line of stroke of the follower passes through the axis of the cam shaft, as shown in Fig. 20.14, is drawn in the similar way as is discussed in Example 20.1.

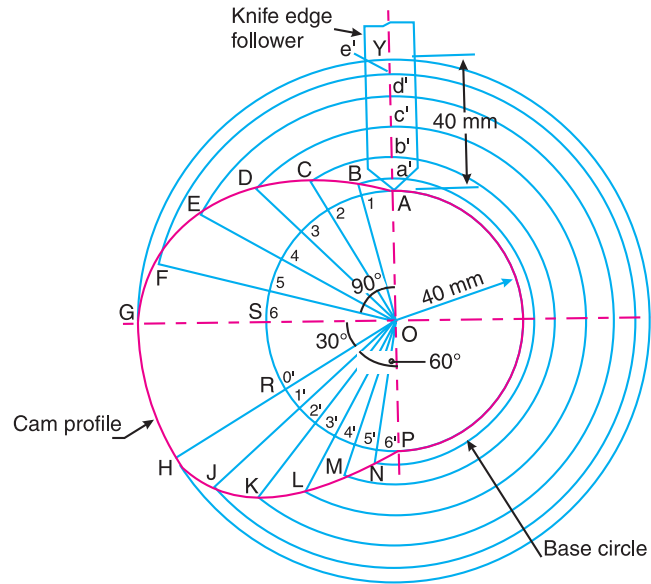

Fig. 20.14

(b) *Profile of the cam when the line of stroke of the follower is offset 20 mm from the axis of the cam shaft*

The profile of the cam when the line of stroke of the follower is offset 20 mm from the axis of the cam shaft, as shown in Fig. 20.15, is drawn in the similar way as discussed in Example 20.1.

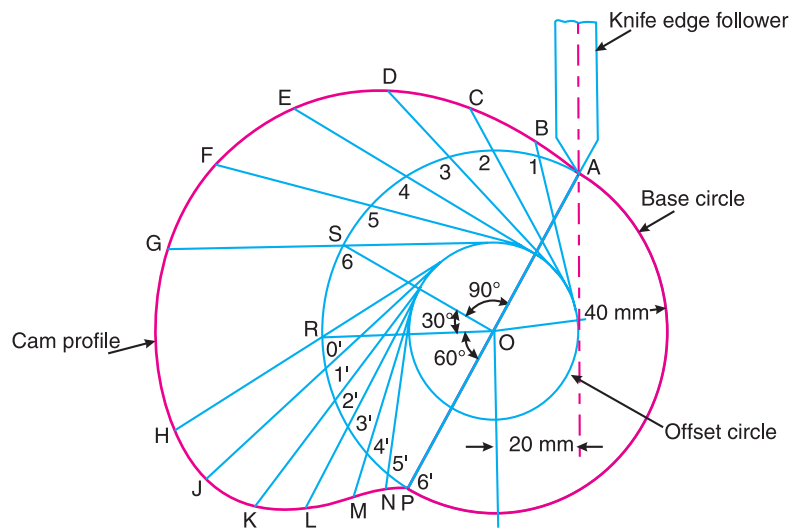

Fig. 20.15

Maximum velocity of the follower during its ascent and descent

We know that angular velocity of the cam,

$$\omega = \frac{2\pi N}{60} = \frac{2\pi \times 240}{60} = 25.14 \text{ rad/s}$$

We also know that the maximum velocity of the follower during its ascent,

$$v_O = \frac{\pi \omega . S}{2\theta_O} = \frac{\pi \times 25.14 \times 0.04}{2 \times 1.571} = 1 \text{ m/s Ans.}$$

and maximum velocity of the follower during its descent,

$$v_R = \frac{\pi \omega . S}{2\theta_R} = \frac{\pi \times 25.14 \times 0.04}{2 \times 1.047} = 1.51 \text{ m/s Ans.}$$

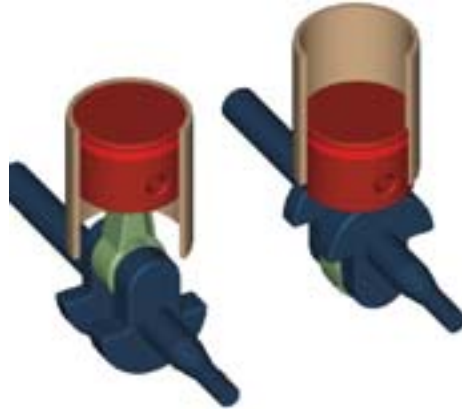

Role of cams in piston movement.

Maximum acceleration of the follower during its ascent and descent

We know that the maximum acceleration of the follower during its ascent,

$$a_O = \frac{\pi^2 \omega^2 . S}{2(\theta_O)^2} = \frac{\pi^2 (25.14)^2 0.04}{2(1.571)^2} = 50.6 \text{ m/s}^2 \text{ Ans.}$$

and maximum acceleration of the follower during its descent,

$$a_R = \frac{\pi^2 \omega^2 . S}{2(\theta_R)^2} = \frac{\pi^2 (25.14)^2 0.04}{2(1.047)^2} = 113.8 \text{ m/s}^2 \text{ Ans.}$$

Example 20.3. A cam, with a minimum radius of 25 mm, rotating clockwise at a uniform speed is to be designed to give a roller follower, at the end of a valve rod, motion described below :

1. To raise the valve through 50 mm during 120° rotation of the cam ;
2. To keep the valve fully raised through next 30°;
3. To lower the valve during next 60°; and
4. To keep the valve closed during rest of the revolution i.e. 150° ;

The diameter of the roller is 20 mm and the diameter of the cam shaft is 25 mm.

Draw the profile of the cam when (a) the line of stroke of the valve rod passes through the axis of the cam shaft, and (b) the line of the stroke is offset 15 mm from the axis of the cam shaft.

The displacement of the valve, while being raised and lowered, is to take place with simple harmonic motion. Determine the maximum acceleration of the valve rod when the cam shaft rotates at 100 r.p.m.

Draw the displacement, the velocity and the acceleration diagrams for one complete revolution of the cam.

Solution. Given : $S = 50 \text{ mm} = 0.05 \text{ m}$; $\theta_O = 120^\circ = 2 \pi/3 \text{ rad} = 2.1 \text{ rad}$; $\theta_R = 60^\circ = \pi/3 \text{ rad} = 1.047 \text{ rad}$; $N = 100 \text{ r.p.m.}$

Since the valve is being raised and lowered with simple harmonic motion, therefore the displacement diagram, as shown in Fig. 20.16 (a), is drawn in the similar manner as discussed in the previous example.

(a) Profile of the cam when the line of stroke of the valve rod passes through the axis of the cam shaft

The profile of the cam, as shown in Fig. 20.17, is drawn as discussed in the following steps :

1. Draw a base circle with centre O and radius equal to the minimum radius of the cam (i.e. 25 mm).

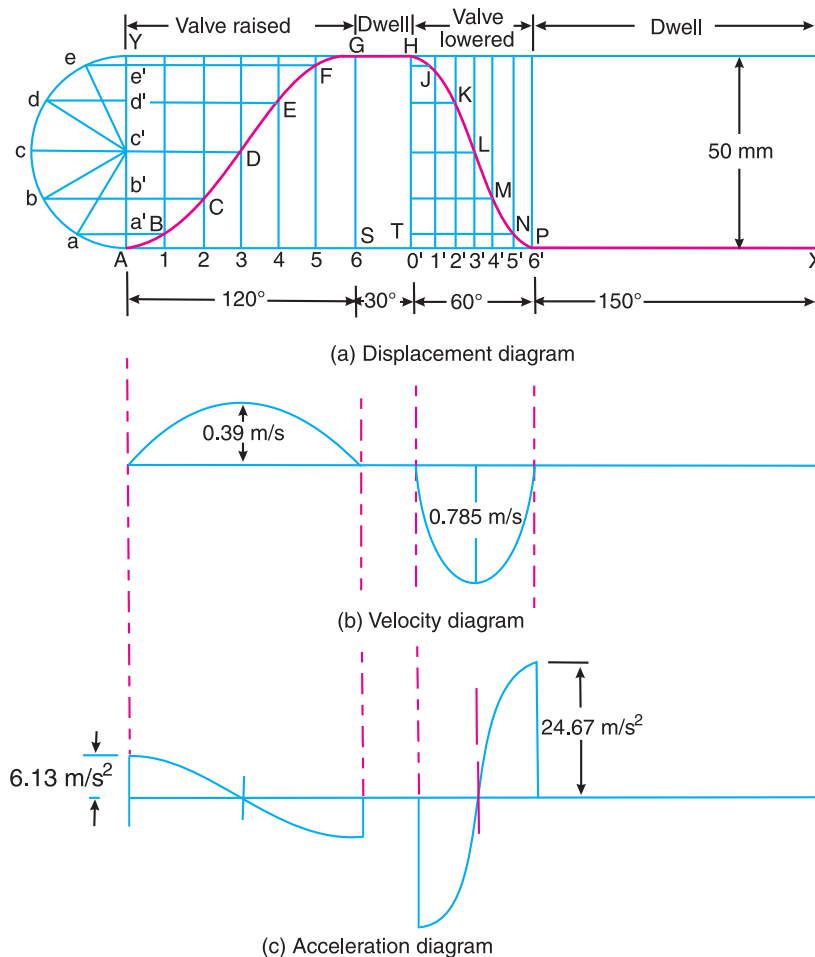

Fig. 20.16

2. Draw a prime circle with centre O and radius,

$$OA = \text{Min. radius of cam} + \frac{1}{2} \text{ Dia. of roller} = 25 + \frac{1}{2} \times 20 = 35 \text{ mm}$$
3. Draw angle $AOS = 120^\circ$ to represent raising or out stroke of the valve, angle $SOT = 30^\circ$ to represent dwell and angle $TOP = 60^\circ$ to represent lowering or return stroke of the valve.
4. Divide the angular displacements of the cam during raising and lowering of the valve (i.e. angle AOS and TOP) into the same number of equal even parts as in displacement diagram.
5. Join the points 1, 2, 3, etc. with the centre O and produce the lines beyond prime circle as shown in Fig. 20.17.
6. Set off $1B, 2C, 3D$ etc. equal to the displacements from displacement diagram.
7. Join the points $A, B, C \dots N, P, A$. The curve drawn through these points is known as **pitch curve**.

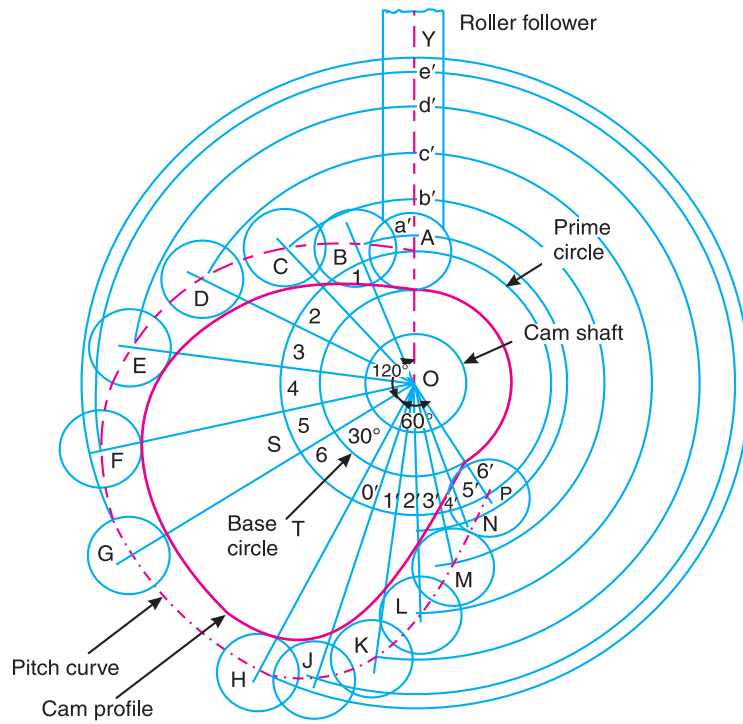

Fig. 20.17

8. From the points A, B, C ... N, P, draw circles of radius equal to the radius of the roller.
9. Join the bottoms of the circles with a smooth curve as shown in Fig. 20.17. This is the required profile of the cam.

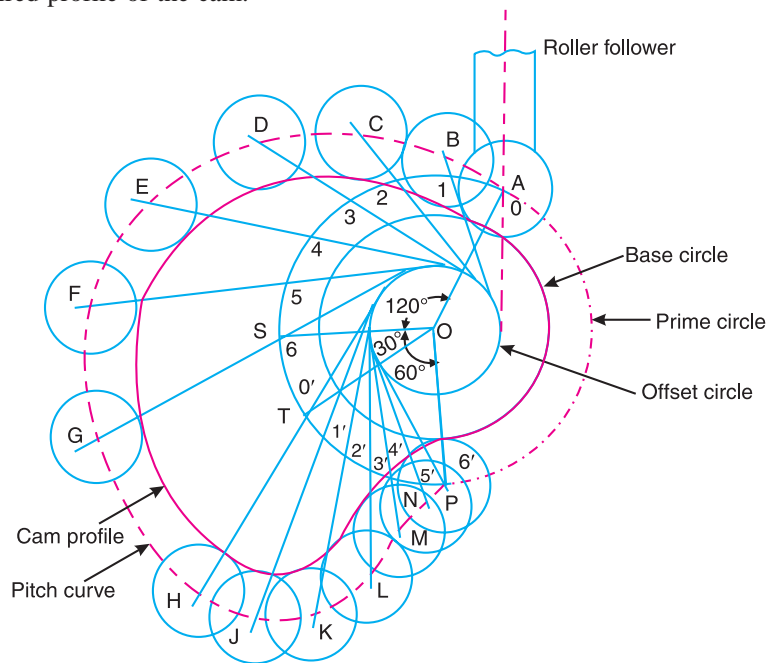

Fig. 20.18

792 • Theory of Machines

(b) Profile of the cam when the line of stroke is offset 15 mm from the axis of the cam shaft

The profile of the cam when the line of stroke is offset from the axis of the cam shaft, as shown in Fig. 20.18, may be drawn as discussed in the following steps :

1. Draw a base circle with centre O and radius equal to 25 mm.
2. Draw a prime circle with centre O and radius $OA = 35$ mm.
3. Draw an off-set circle with centre O and radius equal to 15 mm.
4. Join OA . From OA draw the angular displacements of cam *i.e.* draw angle $AOS = 120^\circ$, angle $SOT = 30^\circ$ and angle $TOP = 60^\circ$.
5. Divide the angular displacements of the cam during raising and lowering of the valve into the same number of equal even parts (*i.e.* six parts) as in displacement diagram.
6. From points 1, 2, 3 etc. and $0', 1', 3', \dots$ etc. on the prime circle, draw tangents to the offset circle.
7. Set off $1B, 2C, 3D \dots$ etc. equal to displacements as measured from displacement diagram.
8. By joining the points $A, B, C \dots M, N, P$, with a smooth curve, we get a **pitch curve**.
9. Now $A, B, C \dots$ etc. as centre, draw circles with radius equal to the radius of roller.
10. Join the bottoms of the circles with a smooth curve as shown in Fig. 20.18. This is the required profile of the cam.

Maximum acceleration of the valve rod

We know that angular velocity of the cam shaft,

$$\omega = \frac{2\pi N}{60} = \frac{2\pi \times 100}{60} = 10.47 \text{ rad/s}$$

We also know that maximum velocity of the valve rod to raise valve,

$$v_O = \frac{\pi \omega S}{2\theta_O} = \frac{\pi \times 10.47 \times 0.05}{2 \times 2.1} = 0.39 \text{ m/s}$$

and maximum velocity of the valve rod to lower the valve,

$$v_R = \frac{\pi \omega S}{2\theta_R} = \frac{\pi \times 10.47 \times 0.05}{2 \times 1.047} = 0.785 \text{ m/s}$$

The velocity diagram for one complete revolution of the cam is shown in Fig. 20.16 (b).

We know that the maximum acceleration of the valve rod to raise the valve,

$$a_O = \frac{\pi^2 \omega^2 S}{2(\theta_O)^2} = \frac{\pi^2 (10.47)^2 0.05}{2(2.1)^2} = 6.13 \text{ m/s}^2 \text{ Ans.}$$

and maximum acceleration of the valve rod to lower the valve,

$$a_R = \frac{\pi^2 \omega^2 S}{2(\theta_R)^2} = \frac{\pi^2 (10.47)^2 0.05}{2(1.047)^2} = 24.67 \text{ m/s}^2 \text{ Ans.}$$

The acceleration diagram for one complete revolution of the cam is shown in Fig. 20.16 (c).

Example 20.4. A cam drives a flat reciprocating follower in the following manner :

During first 120° rotation of the cam, follower moves outwards through a distance of 20 mm with simple harmonic motion. The follower dwells during next 30° of cam rotation. During next 120° of cam rotation, the follower moves inwards with simple harmonic motion. The follower dwells for the next 90° of cam rotation.

The minimum radius of the cam is 25 mm. Draw the profile of the cam.

Construction

Since the follower moves outwards and inwards with simple harmonic motion, therefore the displacement diagram, as shown in Fig. 20.19, is drawn in the similar manner as discussed earlier.

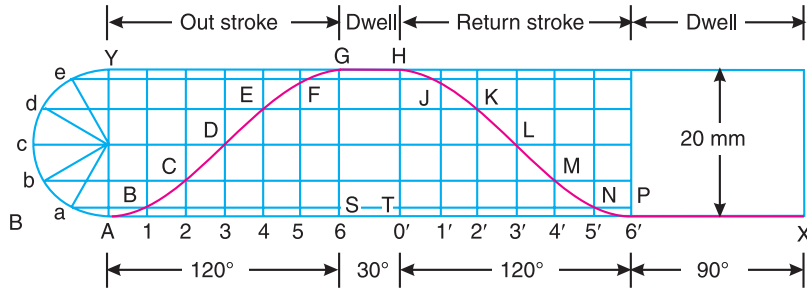

Fig. 20.19

Now the profile of the cam driving a flat reciprocating follower, as shown in Fig. 20.20, is drawn as discussed in the following steps :

1. Draw a base circle with centre O and radius OA equal to the minimum radius of the cam (*i.e.* 25 mm).
2. Draw angle $AOS = 120^\circ$ to represent the outward stroke, angle $SOT = 30^\circ$ to represent dwell and angle $TOP = 120^\circ$ to represent inward stroke.
3. Divide the angular displacement during outward stroke and inward stroke (*i.e.* angles AOS and TOP) into the same number of equal even parts as in the displacement diagram.

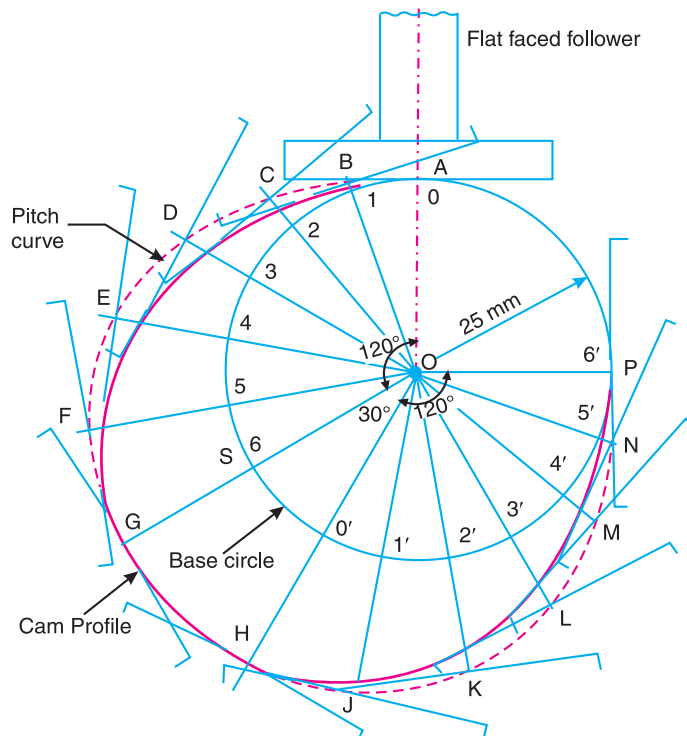

Fig. 20.20

794 • Theory of Machines

4. Join the points 1, 2, 3 . . . etc. with centre O and produce beyond the base circle.
5. From points 1, 2, 3 . . . etc., set off $1B, 2C, 3D . . .$ etc. equal to the distances measured from the displacement diagram.
6. Now at points $B, C, D . . . M, N, P$, draw the position of the flat-faced follower. The axis of the follower at all these positions passes through the cam centre.
7. The curve drawn tangentially to the flat side of the follower is the required profile of the cam, as shown in Fig. 20.20.

Example 20.5. Draw a cam profile to drive an oscillating roller follower to the specifications given below :

- (a) Follower to move outwards through an angular displacement of 20° during the first 120° rotation of the cam ;
- (b) Follower to return to its initial position during next 120° rotation of the cam ;
- (c) Follower to dwell during the next 120° of cam rotation.

The distance between pivot centre and roller centre = 120 mm ; distance between pivot centre and cam axis = 130 mm ; minimum radius of cam = 40 mm ; radius of roller = 10 mm ; inward and outward strokes take place with simple harmonic motion.

Construction

We know that the angular displacement of the roller follower

$$= 20^\circ = 20 \times \pi / 180 = \pi / 9 \text{ rad}$$

Since the distance between the pivot centre and the roller centre (i.e. the radius $A_1 A$) is 120 mm, therefore length of the arc AA_2 , as shown in Fig. 20.21, along which the displacement of the roller actually takes place

$$= 120 \times \pi / 9 = 41.88 \text{ mm}$$

... (\because Length of arc = Radius of arc \times Angle subtended by the arc at the centre in radians)

Since the angle is very small, therefore length of chord AA_2 is taken equal to the length of arc AA_2 . Thus in order to draw the displacement diagram, we shall take lift of the follower equal to length of chord AA_2 i.e. 41.88 mm.

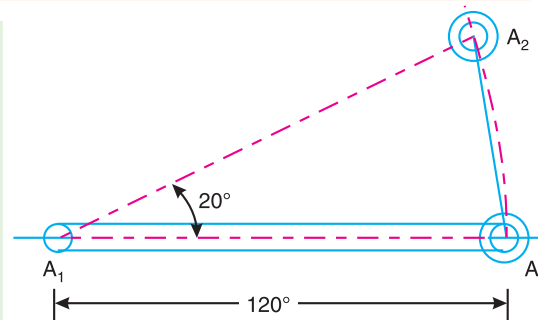

Fig. 20.21

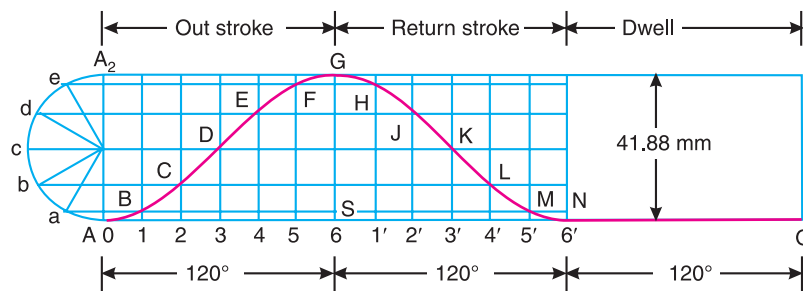

Fig. 20.22

The outward and inward strokes take place with simple harmonic motion, therefore the displacement diagram, as shown in Fig. 20.22, is drawn in the similar way as discussed in Example 20.4.

The profile of the cam to drive an oscillating roller follower, as shown in Fig. 20.23, is drawn as discussed in the following steps :

1. First of all, draw a base circle with centre O and radius equal to the minimum radius of the cam (*i.e.* 40 mm)
2. Draw a prime circle with centre O and radius OA
 $= \text{Min. radius of cam} + \text{radius of roller} = 40 + 10 = 50 \text{ mm}$
3. Now locate the pivot centre A_1 such that $OA_1 = 130 \text{ mm}$ and $AA_1 = 120 \text{ mm}$. Draw a pivot circle with centre O and radius $OA_1 = 130 \text{ mm}$.

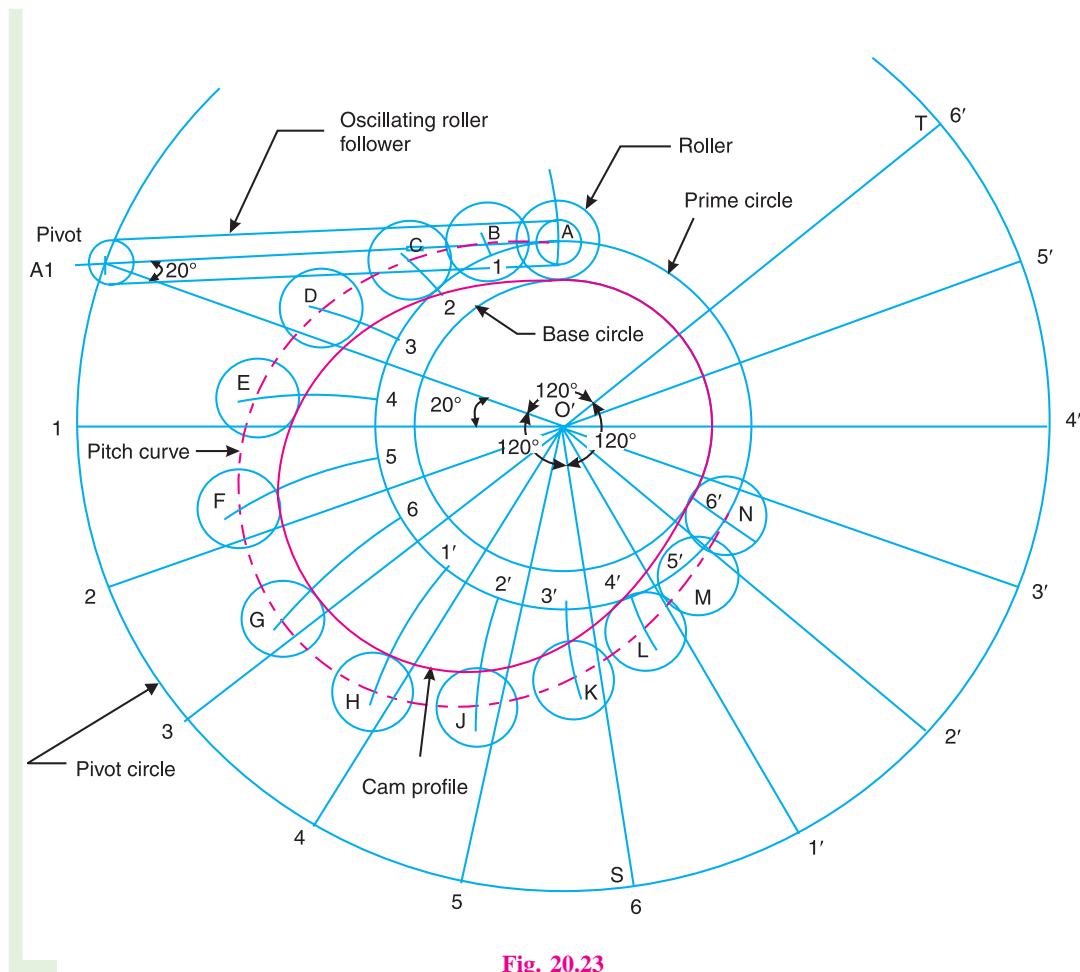

Fig. 20.23

4. Join OA_1 . Draw angle $A_1OS = 120^\circ$ to represent the outward stroke of the follower, angle $SOT = 120^\circ$ to represent the inward stroke of the follower and angle $TOA_1 = 120^\circ$ to represent the dwell.
5. Divide angles A_1OS and SOT into the same number of equal even parts as in the displacement diagram and mark points 1, 2, 3 ... 4', 5', 6' on the pivot circle.
6. Now with points 1, 2, 3 ... 4', 5', 6' (on the pivot circle) as centre and radius equal to A_1A (*i.e.* 120 mm) draw circular arcs to intersect the prime circle at points 1, 2, 3 ... 4', 5', 6'.

796 • Theory of Machines

7. Set off the distances $1B, 2C, 3D \dots 4'L, 5'M$ along the arcs drawn equal to the distances as measured from the displacement diagram.
8. The curve passing through the points $A, B, C \dots L, M, N$ is known as pitch curve.
9. Now draw circles with $A, B, C, D \dots L, M, N$ as centre and radius equal to the radius of roller.
10. Join the bottoms of the circles with a smooth curve as shown in Fig. 20.23. This is the required profile of the cam.

Example 20.6. A cam, with a minimum radius of 50 mm, rotating clockwise at a uniform speed, is required to give a knife edge follower the motion as described below :

1. To move outwards through 40 mm during 100° rotation of the cam ; 2. To dwell for next 80° ; 3. To return to its starting position during next 90° , and 4. To dwell for the rest period of a revolution i.e. 90° .

Draw the profile of the cam

- (i) when the line of stroke of the follower passes through the centre of the cam shaft, and
- (ii) when the line of stroke of the follower is off-set by 15 mm.

The displacement of the follower is to take place with uniform acceleration and uniform retardation. Determine the maximum velocity and acceleration of the follower when the cam shaft rotates at 900 r.p.m.

Draw the displacement, velocity and acceleration diagrams for one complete revolution of the cam.

Solution. Given : $S = 40 \text{ mm} = 0.04 \text{ m}$; $\theta_0 = 100^\circ = 100 \times \pi/180 = 1.745 \text{ rad}$; $\theta_R = 90^\circ = \pi/2 = 1.571 \text{ rad}$; $N = 900 \text{ r.p.m.}$

First of all, the displacement diagram, as shown in Fig. 20.24 (a), is drawn as discussed in the following steps :

1. Draw a horizontal line $ASTPQ$ such that AS represents the angular displacement of the cam during outward stroke (i.e. 100°) to some suitable scale. The line ST represents the dwell period of 80° after outward stroke. The line TP represents the angular displacement of the cam during return stroke (i.e. 90°) and the line PQ represents the dwell period of 90° after return stroke.
2. Divide AS and TP into any number of equal even parts (say six).
3. Draw vertical lines through points 0, 1, 2, 3 etc. and equal to the lift of the valve i.e. 40 mm.
4. Divide the vertical lines 3-f and $3'-f'$ into six equal parts as shown by points $a, b, c \dots$ and $a', b', c' \dots$ in Fig. 20.24 (a).
5. Since the follower moves with equal uniform acceleration and uniform retardation, therefore the displacement diagram of the outward and return stroke consists of a double parabola.
6. Join Aa, Ab and Ac intersecting the vertical lines through 1, 2 and 3 at B, C and D respectively.
7. Join the points B, C and D with a smooth curve. This is the required parabola for the half outstroke of the valve. Similarly the other curves may be drawn as shown in Fig. 20.24.
8. The curve $A B C \dots N P Q$ is the required displacement diagram.

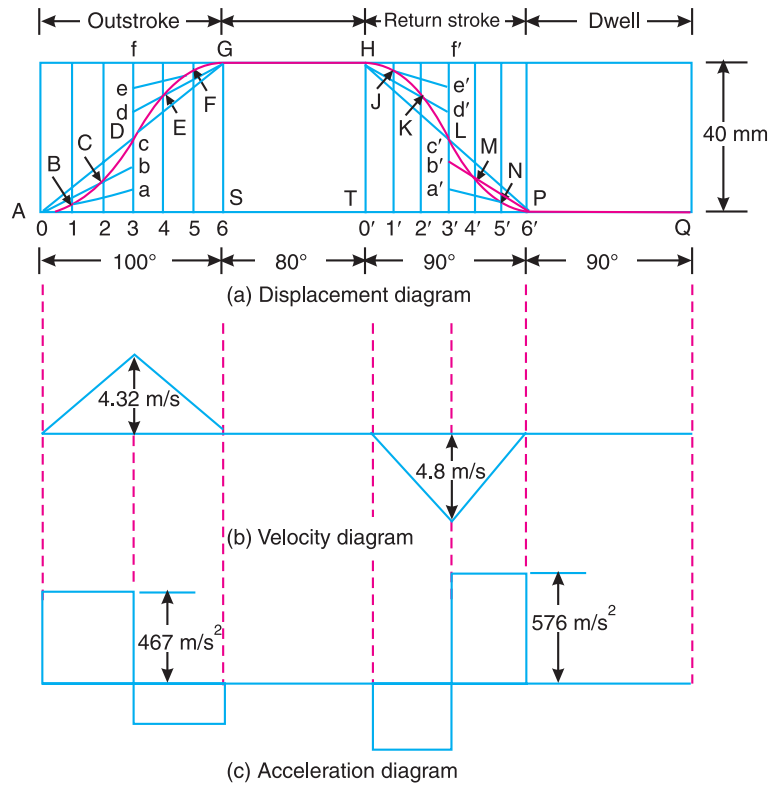

Fig. 20.24

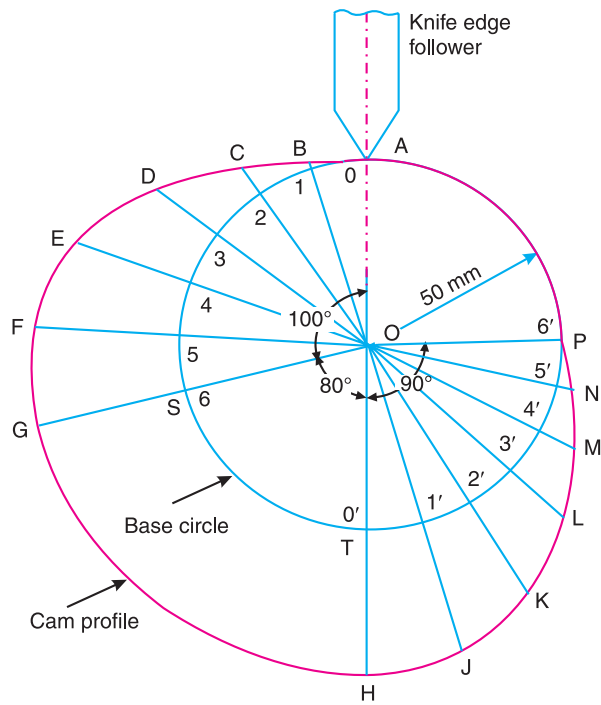

Fig. 20.25

(i) Profile of the cam when the line of stroke of the follower passes through the centre of the cam shaft

The profile of the cam when the line of stroke of the follower passes through the centre of cam shaft, as shown in Fig. 20.25, may be drawn as discussed in the following steps :

1. Draw a base circle with centre O and radius 50 mm (equal to minimum radius of the cam).
2. Divide the base circle such that angle $AOS = 100^\circ$; angle $SOT = 80^\circ$ and angle $TOP = 90^\circ$.
3. Divide angles AOS and TOP into the same number of equal even parts as in displacement diagram (*i.e.* six parts).
4. Join the points 1, 2, 3 . . . and 1', 2', 3', . . . with centre O and produce these lines beyond the base circle.
5. From points 1, 2, 3 . . . and 1', 2', 3', . . . mark the displacements 1B, 2C, 3D . . . etc. as measured from the displacement diagram.
6. Join the points A, B, C . . . M, N, P with a smooth curve as shown in Fig. 20.25. This is the required profile of the cam.

(ii) Profile of the cam when the line of stroke of the follower is offset by 15 mm

The profile of the cam when the line of stroke of the follower is offset may be drawn as discussed in Example 20.2. The profile of cam is shown in Fig. 20.26.

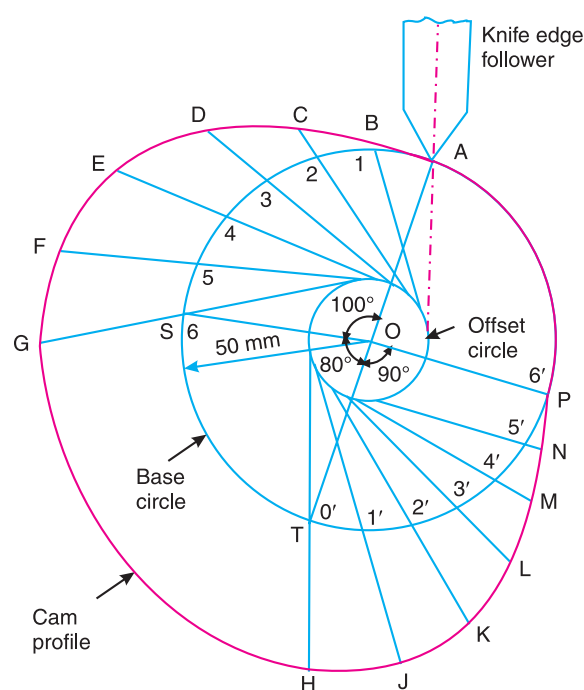

Fig. 20.26

Maximum velocity of the follower during out stroke and return stroke

We know that angular velocity of the cam shaft,

$$\omega = \frac{2\pi N}{60} = \frac{2\pi \times 900}{60} = 94.26 \text{ rad/s}$$

We also know that the maximum velocity of the follower during out stroke,

$$v_O = \frac{2\omega.S}{\theta_O} = \frac{2 \times 94.26 \times 0.04}{1.745} = 4.32 \text{ m/s Ans.}$$

and maximum velocity of the follower during return stroke,

$$v_R = \frac{2\omega.S}{\theta_R} = \frac{2 \times 94.26 \times 0.04}{1.571} = 4.8 \text{ m/s Ans.}$$

The velocity diagram is shown in Fig. 20.24 (b).

Maximum acceleration of the follower during out stroke and return stroke

We know that the maximum acceleration of the follower during out stroke,

$$a_O = \frac{4\omega^2.S}{(\theta_O)^2} = \frac{4(94.26)^2 \cdot 0.04}{(1.745)^2} = 467 \text{ m/s}^2 \text{ Ans.}$$

and maximum acceleration of the follower during return stroke,

$$a_R = \frac{4\omega^2.S}{(\theta_R)^2} = \frac{4(94.26)^2 \cdot 0.04}{(1.571)^2} = 576 \text{ m/s}^2 \text{ Ans.}$$

The acceleration diagram is shown in Fig. 20.24 (c).



A type of roller follower.

Example 20.7. Design a cam for operating the exhaust valve of an oil engine. It is required to give equal uniform acceleration and retardation during opening and closing of the valve each of which corresponds to 60° of cam rotation. The valve must remain in the fully open position for 20° of cam rotation.

The lift of the valve is 37.5 mm and the least radius of the cam is 40 mm. The follower is provided with a roller of radius 20 mm and its line of stroke passes through the axis of the cam.

Construction

First of all, the displacement diagram, as shown in Fig. 20.27, is drawn as discussed in the following steps :

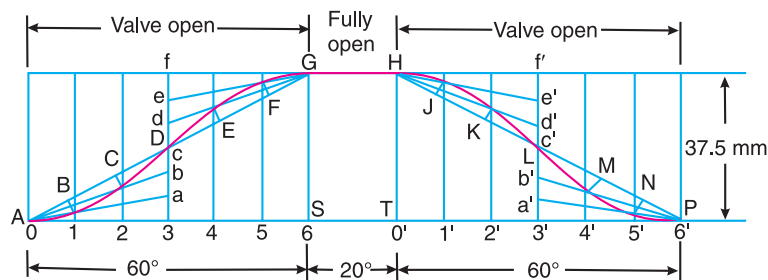

Fig. 20.27

1. Draw a horizontal line *ASTP* such that *AS* represents the angular displacement of the cam during opening (*i.e.* out stroke) of the valve (equal to 60°), to some suitable scale. The line *ST* represents the dwell period of 20° *i.e.* the period during which the valve remains

800 • Theory of Machines

fully open and TP represents the angular displacement during closing (*i.e.* return stroke) of the valve which is equal to 60° .

2. Divide AS and TP into any number of equal even parts (say six).
3. Draw vertical lines through points 0, 1, 2, 3 etc. and equal to lift of the valve *i.e.* 37.5 mm.
4. Divide the vertical lines $3f$ and $3'f'$ into six equal parts as shown by the points $a, b, c \dots$ and $a', b', c' \dots$ in Fig. 20.27.
5. Since the valve moves with equal uniform acceleration and retardation, therefore the displacement diagram for opening and closing of a valve consists of double parabola.
6. Complete the displacement diagram as shown in Fig. 20.27.

Now the profile of the cam, with a roller follower when its line of stroke passes through the axis of cam, as shown in Fig. 20.28, is drawn in the similar way as discussed in Example 20.3.

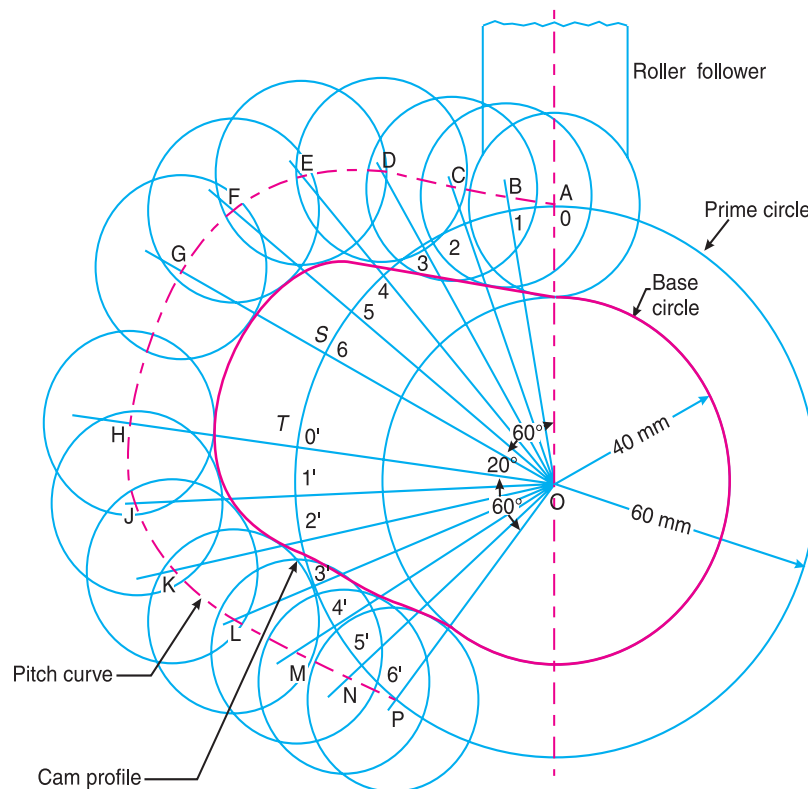

Fig. 20.28

Example 20.8. A cam rotating clockwise at a uniform speed of 1000 r.p.m. is required to give a roller follower the motion defined below :

1. Follower to move outwards through 50 mm during 120° of cam rotation,
2. Follower to dwell for next 60° of cam rotation,
3. Follower to return to its starting position during next 90° of cam rotation,
4. Follower to dwell for the rest of the cam rotation.

The minimum radius of the cam is 50 mm and the diameter of roller is 10 mm. The line of stroke of the follower is off-set by 20 mm from the axis of the cam shaft. If the displacement of the

follower takes place with uniform and equal acceleration and retardation on both the outward and return strokes, draw profile of the cam and find the maximum velocity and acceleration during out stroke and return stroke.

Solution. Given : $N = 1000$ r.p.m. ; $S = 50$ mm = 0.05 m ; $\theta_O = 120^\circ = 2 \pi/3$ rad = 2.1 rad ; $\theta_R = 90^\circ = \pi/2$ rad = 1.571 rad

Since the displacement of the follower takes place with uniform and equal acceleration and retardation on both outward and return strokes, therefore the displacement diagram, as shown in Fig. 20.29, is drawn in the similar manner as discussed in the previous example. But in this case, the angular displacement and stroke of the follower is divided into eight equal parts.

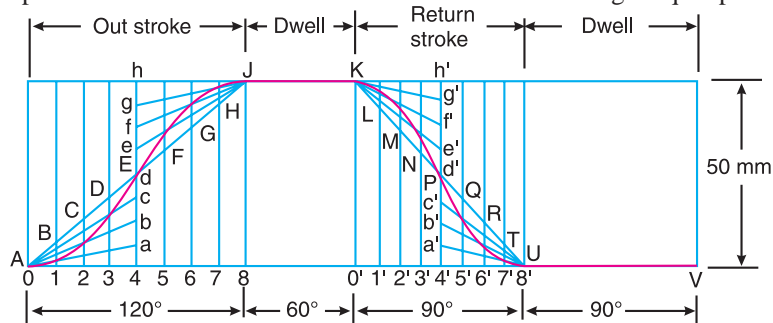

Fig. 20.29

Now, the profile of the cam, as shown in Fig. 20.30, is drawn as discussed in the following steps :

1. Draw a base circle with centre O and radius equal to the minimum radius of the cam (i.e. 50 mm).

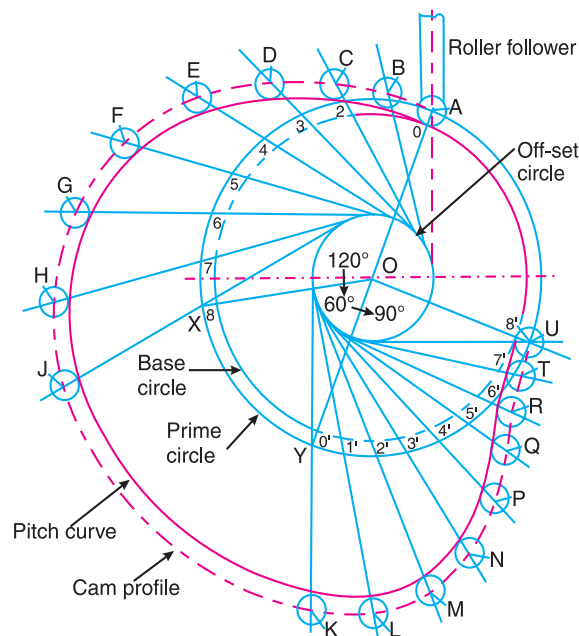

Fig. 20.30

802 • Theory of Machines

2. Draw a prime circle with centre O and radius
 $OA = \text{Minimum radius of the cam} + \text{radius of roller} = 50 + 5 = 55 \text{ mm}$
3. Draw an off-set circle with centre O and radius equal to 20 mm.
4. Divide the angular displacements of the cam during out stroke and return stroke into eight equal parts as shown by points $0, 1, 2 \dots$ and $0', 1', 2' \dots$ etc. on the prime circle in Fig. 20.30.
5. From these points draw tangents to the off-set circle.
6. Set off $1B, 2C, 3D \dots$ etc. equal to the displacements as measured from the displacement diagram.
7. By joining the points $A, B, C \dots T, U, A$ with a smooth curve, we get a pitch curve.
8. Now from points $A, B, C \dots T, U$, draw circles with radius equal to the radius of the roller.
9. Join the bottoms of these circles with a smooth curve to obtain the profile of the cam as shown in Fig. 20.30.

Maximum velocity of the follower during out stroke and return stroke

We know that angular velocity of the cam,

$$\omega = \frac{2\pi N}{60} = \frac{2\pi \times 1000}{60} = 104.7 \text{ rad/s.}$$

We also know that the maximum velocity of the follower during outstroke,

$$v_O = \frac{2\omega.S}{\theta_O} = \frac{2 \times 104.7 \times 0.05}{2.1} = 5 \text{ m/s Ans.}$$

and maximum velocity of the follower during return stroke,

$$v_R = \frac{2\omega.S}{\theta_R} = \frac{2 \times 104.7 \times 0.05}{1.571} = 6.66 \text{ m/s Ans.}$$

Maximum acceleration of the follower during out stroke and return stroke

We know that the maximum acceleration of the follower during out stroke,

$$a_O = \frac{4\omega^2.S}{(\theta_O)^2} = \frac{4(104.7)^2 \times 0.05}{(2.1)^2} = 497.2 \text{ m/s}^2 \text{ Ans.}$$

and maximum acceleration of the follower during return stroke,

$$a_R = \frac{4\omega^2.S}{(\theta_R)^2} = \frac{4(104.7)^2 \times 0.05}{(1.571)^2} = 888 \text{ m/s}^2 \text{ Ans.}$$



A rocker using a cam.

Example 20.9. Construct the profile of a cam to suit the following specifications :

Cam shaft diameter = 40 mm ; Least radius of cam = 25 mm ; Diameter of roller = 25 mm ; Angle of lift = 120° ; Angle of fall = 150° ; Lift of the follower = 40 mm ; Number of pauses are two of equal interval between motions.

During the lift, the motion is S.H.M. During the fall the motion is uniform acceleration and deceleration. The speed of the cam shaft is uniform. The line of stroke of the follower is off-set 12.5 mm from the centre of the cam.

Construction

First of all the displacement diagram, as shown in Fig. 20.31, is drawn as discussed in the following steps :

1. Since the follower moves with simple harmonic motion during lift (i.e. for 120° of cam rotation), therefore draw the displacement curve ADG in the similar manner as discussed in Example 20.2.
2. Since the follower moves with uniform acceleration and deceleration during fall (i.e. for 150° of cam rotation), therefore draw the displacement curve HLP consisting of double parabola as discussed in Example 20.6.

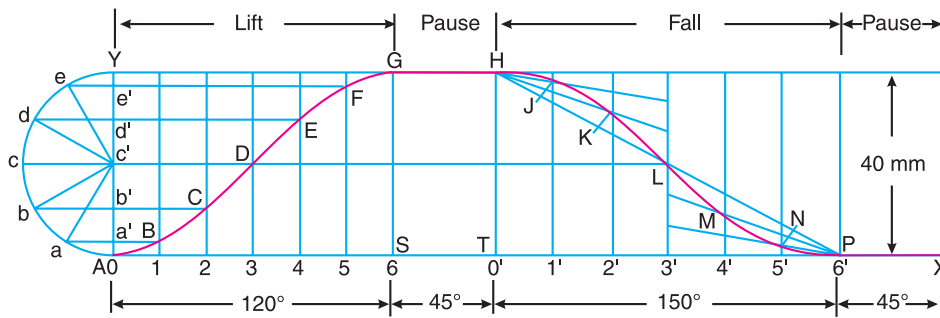

Fig. 20.31

Now the profile of the cam, when the line of stroke of the follower is off-set 12.5 mm from the centre of the cam, as shown in Fig. 20.32, is drawn as discussed in the following steps :

1. Draw a base circle with centre O and radius equal to the least radius of cam (i.e. 25 mm).

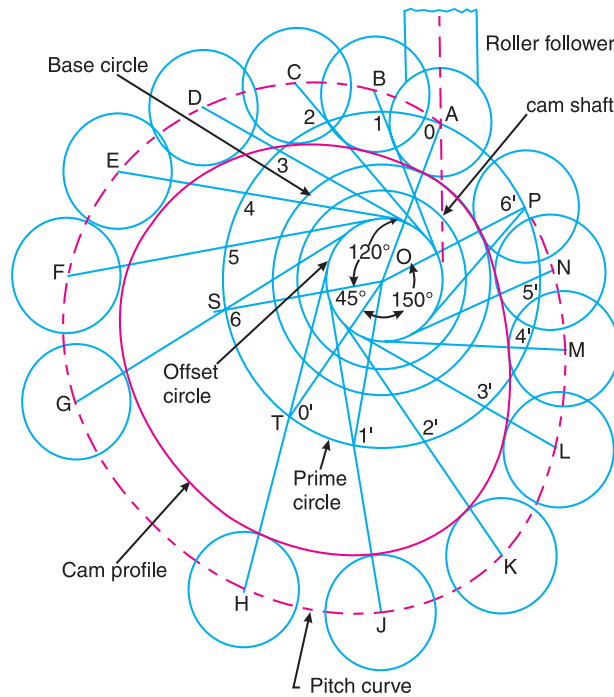

Fig. 20.32

804 • Theory of Machines

2. Draw a prime circle with centre O and radius,

$$OA = \text{Least radius of cam} + \text{radius of roller} = 25 + 25/2 = 37.5 \text{ mm}$$
3. Draw a circle with centre O and radius equal to 20 mm to represent the cam shaft.
4. Draw an offset circle with centre O and radius equal to 12.5 mm.
5. Join OA . From OA draw angular displacements of the cam, *i.e.* draw angle $AOS = 120^\circ$ to represent lift of the follower, angle $SOT = 45^\circ$ to represent pause, angle $TOP = 150^\circ$ to represent fall of the follower and angle $POA = 45^\circ$ to represent pause.

Note. Since the number of pauses are two of equal interval between motions (*i.e.* between lift and fall of the follower), therefore angular displacement of each pause

$$= \frac{360^\circ - (120^\circ + 150^\circ)}{2} = 45^\circ$$

6. Divide the angular displacements during lift and fall (*i.e.* angle AOS and TOP) into the same number of equal even parts (*i.e.* six parts) as in the displacement diagram.
7. From points 1, 2, 3 . . . etc. and $0', 1', 2', 3' . . .$ etc. on the prime circle, draw tangents to the off-set circle.
8. Set off $1B, 2C, 3D . . .$ etc. equal to the displacements as measured from the displacement diagram.
9. By joining the points $A, B, C . . . M, N, P$ with a smooth curve, we get a pitch curve.
10. Now with $A, B, C . . .$ etc. as centre, draw circles with radius equal to the radius of roller.
11. Join the bottoms of the circles with a smooth curve as shown in Fig. 20.32. This is the required profile of the cam.

Example 20.10. It is required to set out the profile of a cam to give the following motion to the reciprocating follower with a flat mushroom contact face :

- (i) Follower to have a stroke of 20 mm during 120° of cam rotation ;
- (ii) Follower to dwell for 30° of cam rotation ;
- (iii) Follower to return to its initial position during 120° of cam rotation ; and
- (iv) Follower to dwell for remaining 90° of cam rotation.

The minimum radius of the cam is 25 mm. The out stroke of the follower is performed with simple harmonic motion and the return stroke with equal uniform acceleration and retardation.

Construction

Since the out stroke of the follower is performed with simple harmonic motion and the return stroke with uniform acceleration and retardation, therefore the displacement diagram, as shown in Fig. 20.33, is drawn in the similar manner as discussed in the previous example.

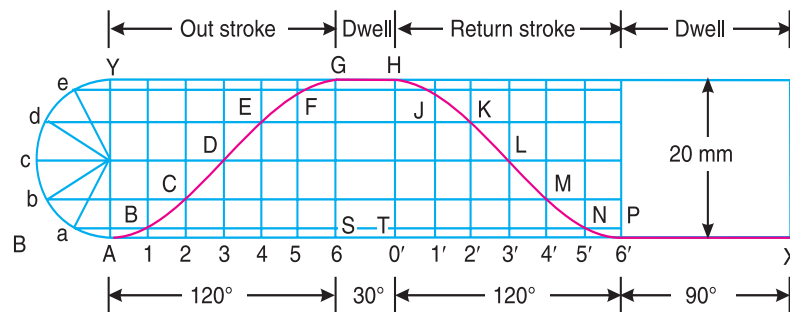

Fig. 20.33

The profile of the cam with a flat mushroom contact face reciprocating follower, as shown in Fig. 20.34, is drawn in the similar way as discussed in Example 20.4.

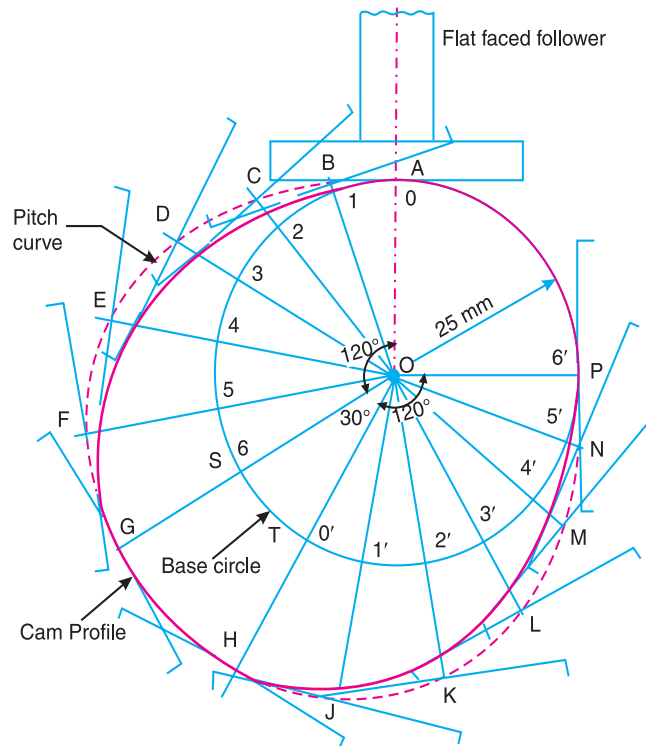

Fig. 20.34

Example 20.11. It is required to set out the profile of a cam with oscillating follower for the following motion :

(a) Follower to move outward through an angular displacement of 20° during 90° of cam rotation ; (b) Follower to dwell for 45° of cam rotation ; (c) Follower to return to its original position of zero displacement in 75° of cam rotation ; and (d) Follower to dwell for the remaining period of the revolution of the cam.

The distance between the pivot centre and the follower roller centre is 70 mm and the roller diameter is 20 mm. The minimum radius of the cam corresponds to the starting position of the follower as given in (a). The location of the pivot point is 70 mm to the left and 60 mm above the axis of rotation of the cam. The motion of the follower is to take place with S.H.M. during out stroke and with uniform acceleration and retardation during return stroke.

Construction

We know that the angular displacement of the roller follower,

$$= 20^\circ = 20 \times \pi / 180 = \pi / 9 \text{ rad}$$

Since the distance between the pivot centre and the roller centre (i.e. radius A_1A) is 70 mm, therefore length of arc AA_2 , as shown in Fig. 20.35, along which the displacement of the roller actually takes place

$$= 70 \times \pi / 9 = 24.5 \text{ mm}$$

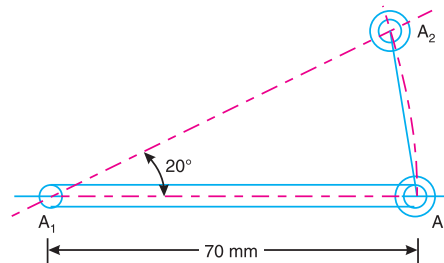

Fig. 20.35

806 • Theory of Machines

Since the angle is very small, therefore length of chord AA_2 is taken equal to the length of arc AA_2 . Thus in order to draw the displacement diagram, we shall take lift of the follower equal to the length of chord AA_2 i.e. 24.5 mm.

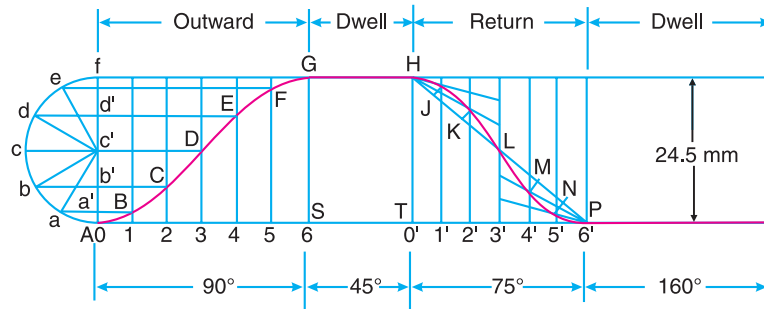

Fig. 20.36

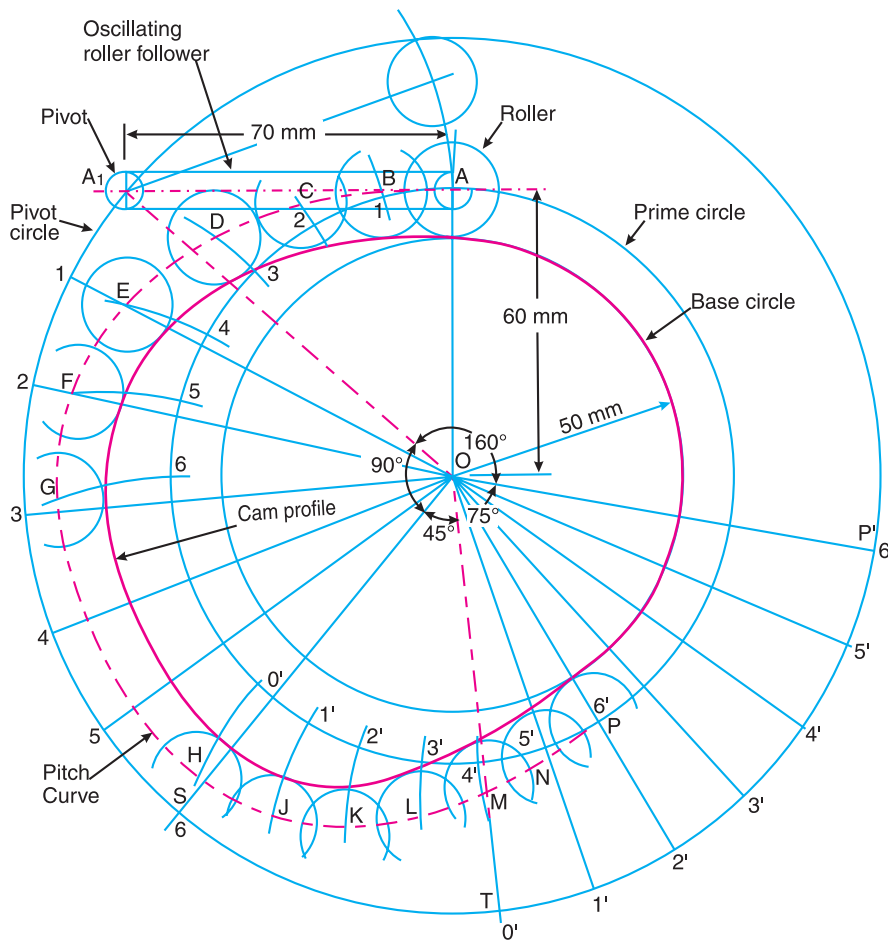

Fig. 20.37

The follower moves with simple harmonic motion during out stroke and with uniform acceleration and retardation during return stroke. Therefore, the displacement diagram, as shown in Fig. 20.36, is drawn in the similar way as discussed in the previous example.

The profile of the cam, as shown in Fig. 20.37, is drawn as discussed in the following steps :

1. First of all, locate the pivot point A_1 which is 70 mm to the left and 60 mm above the axis of the cam.
2. Since the distance between the pivot centre A_1 and the follower roller centre A is 70 mm and the roller diameter is 20 mm, therefore draw a circle with centre A and radius equal to the radius of roller *i.e.* 10 mm.
3. We find that the minimum radius of the cam

$$= 60 - 10 = 50 \text{ mm}$$

∴ Radius of the prime circle,

$$OA = \text{Min. radius of cam} + \text{Radius of roller} = 50 + 10 = 60 \text{ mm}$$

4. Now complete the profile of the cam in the similar way as discussed in Example 20.5.

Example 20.12. Draw the profile of the cam when the roller follower moves with cycloidal motion during out stroke and return stroke, as given below :

1. Out stroke with maximum displacement of 31.4 mm during 180° of cam rotation,
2. Return stroke for the next 150° of cam rotation,
3. Dwell for the remaining 30° of cam rotation.

The minimum radius of the cam is 15 mm and the roller diameter of the follower is 10 mm. The axis of the roller follower is offset by 10 mm towards right from the axis of cam shaft.

Construction

First of all, the displacement diagram, as shown in Fig. 20.38, is drawn as discussed in the following steps :

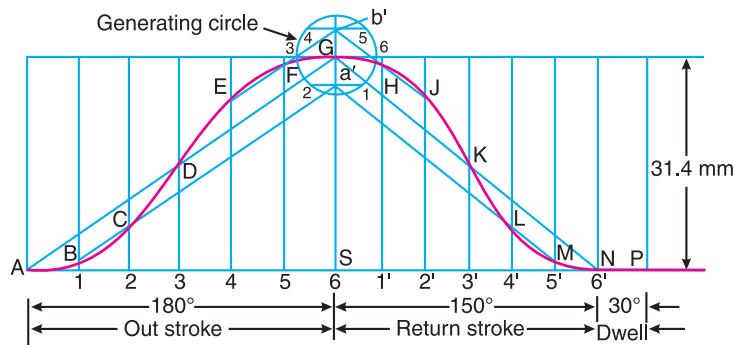

Fig. 20.38

1. Draw horizontal line ASP such that $AS = 180^\circ$ to represent the out stroke, $SN = 150^\circ$ to represent the return stroke and $NP = 30^\circ$ to represent the dwell period.
2. Divide AS and SN into any number of even equal parts (say six).
3. From the points 1, 2, 3 . . . etc. draw vertical lines and set-off equal to the stroke of the follower.
4. From a point G draw a generating circle of radius,

$$r = \frac{\text{Stroke}}{2\pi} = \frac{31.4}{2\pi} = 5 \text{ mm}$$

5. Divide the generating circle into six equal parts and from these points draw horizontal lines to meet the vertical diameter at a' , G and b' .
6. Join AG and GN . From point a' , draw lines parallel to AG and GN to intersect the vertical lines drawn through 1, 2, 4' and 5' at B , C , L and M respectively. Similarly draw parallel lines from b' intersecting the vertical lines through 4, 5, 1' and 2' at E , F , H and J respectively.

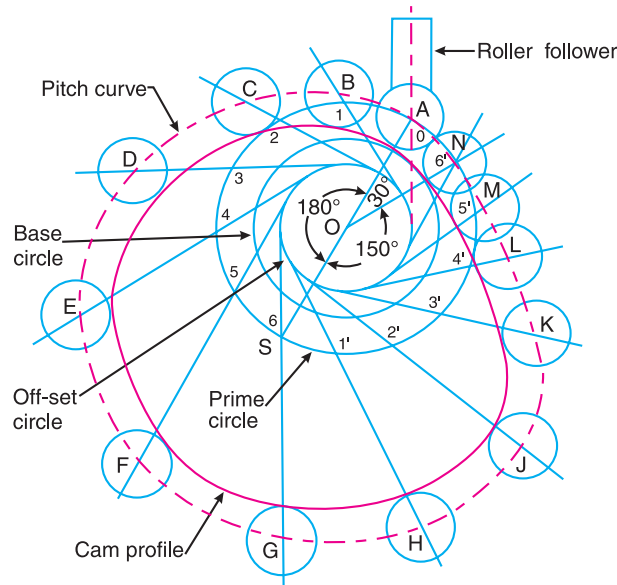

Fig. 20.39

7. Join the points $A, B, C \dots L, M, N$ with a smooth curve.
8. The curve $A B C \dots L M N$ is the required displacement diagram.

Now the profile of the cam, as shown in Fig. 20.39, may be drawn in the similar way as discussed in Example 20.9.

20.11. Cams with Specified Contours

In the previous articles, we have discussed about the design of the profile of a cam when the follower moves with the specified motion. But, the shape of the cam profile thus obtained may be difficult and costly to manufacture. In actual practice, the cams with specified contours (cam profiles consisting of circular arcs and straight lines are preferred) are assumed and then motion of the follower is determined.

20.12. Tangent Cam with Reciprocating Roller Follower

When the flanks of the cam are straight and tangential to the base circle and nose circle, then the cam is known as a **tangent cam**, as shown in Fig. 20.40. These cams are usually symmetrical about the centre line of the cam shaft. Such type of cams are used for operating the inlet and exhaust valves of internal combustion engines. We shall now derive the expressions for displacement, velocity and acceleration of the follower for the following two cases :

1. When the roller has contact with the straight flanks ; and

2. When the roller has contact with the nose.

Let r_1 = Radius of the base circle or minimum radius of the cam,
 r_2 = Radius of the roller,
 r_3 = Radius of nose,
 α = Semi-angle of action of cam or angle of ascent,
 θ = Angle turned by the cam from the beginning of the roller displacement,
 ϕ = Angle turned by the cam for contact of roller with the straight flank, and
 ω = Angular velocity of the cam.

1. *When the roller has contact with straight flanks.* A roller having contact with straight flanks is shown in Fig. 20.40. The point O is the centre of cam shaft and the point K is the centre of nose. EG and PQ are straight flanks of the cam. When the roller is in lowest position, (*i.e.* when the roller has contact with the straight flank at E), the centre of roller lies at B on the pitch curve. Let the cam has turned through an angle* θ (less than ϕ) for the roller to have contact at any point (say F) between the straight flanks EG . The centre of roller at this stage lies at C . Therefore displacement (or lift or stroke) of the roller from its lowest position is given by

$$x = OC - OB = \frac{OB}{\cos \theta} - OB = OB \left(\frac{1 - \cos \theta}{\cos \theta} \right)$$

$$= (r_1 + r_2) \left(\frac{1 - \cos \theta}{\cos \theta} \right) \quad \dots (\because OB = OE + EB = r_1 + r_2) \quad \dots (i)$$

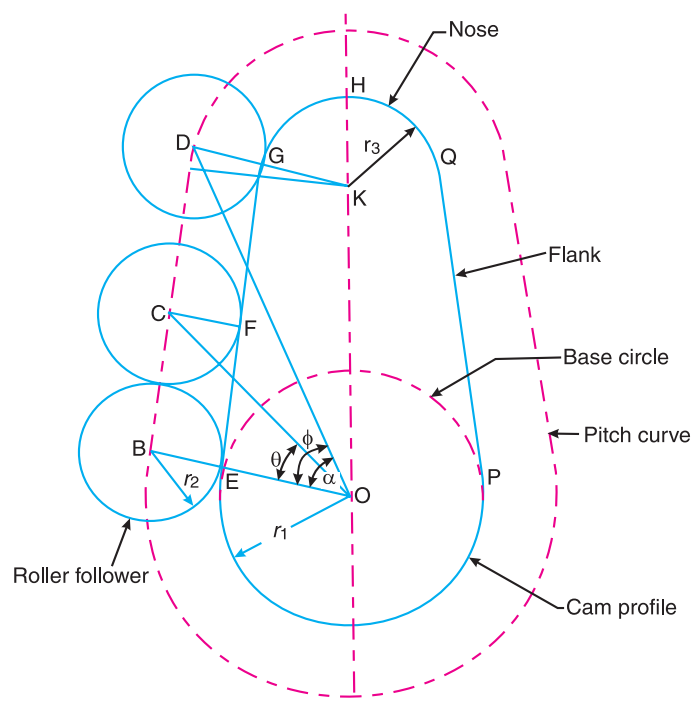

Fig. 20.40. Tangent cam with reciprocating roller follower having contact with straight flanks.

* Since the cam is assumed to be stationary, the angle θ is turned by the roller.

810 • Theory of Machines

Differentiating equation (i) with respect to t , we have velocity of the follower,

$$v = \frac{dx}{dt} = \frac{dx}{d\theta} \times \frac{d\theta}{dt} = (r_1 + r_2) \left(\frac{\sin \theta}{\cos^2 \theta} \right) \frac{d\theta}{dt}$$

$$= \omega(r_1 + r_2) \left(\frac{\sin \theta}{\cos^2 \theta} \right) \quad \dots (\because d\theta/dt = \omega) \quad \dots \text{(ii)}$$

From equation (ii), we see that when θ increases, $\sin \theta$ increases and $\cos \theta$ decreases. In other words, $\sin \theta / \cos^2 \theta$ increases. Thus the velocity is maximum where θ is maximum. This happens when $\theta = \phi$ i.e. when the roller just leaves contact with the straight flank at G or when the straight flank merges into a circular nose.

\therefore Maximum velocity of the follower,

$$v_{max} = \omega(r_1 + r_2) \left(\frac{\sin \phi}{\cos^2 \phi} \right)$$

Now differentiating equation (ii) with respect to t , we have acceleration of the follower,

$$a = \frac{dv}{dt} = \frac{dv}{d\theta} \times \frac{d\theta}{dt}$$

$$= \omega(r_1 + r_2) \left(\frac{\cos^2 \theta \cdot \cos \theta - \sin \theta \times 2 \cos \theta \times -\sin \theta}{\cos^4 \theta} \right) \frac{d\theta}{dt}$$

$$= \omega^2 (r_1 + r_2) \left(\frac{\cos^2 \theta + 2 \sin^2 \theta}{\cos^3 \theta} \right) \quad \dots \left(\because \frac{d\theta}{dt} = \omega \right)$$

$$= \omega^2 (r_1 + r_2) \left[\frac{\cos^2 \theta + 2(1 - \cos^2 \theta)}{\cos^3 \theta} \right]$$

$$= \omega^2 (r_1 + r_2) \left(\frac{2 - \cos^2 \theta}{\cos^3 \theta} \right) \quad \dots \text{(iii)}$$

A little consideration will show that the acceleration is minimum when $\frac{2 - \cos^2 \theta}{\cos^3 \theta}$ is minimum. This is only possible when $(2 - \cos^2 \theta)$ is minimum and $\cos^3 \theta$ is maximum. This happens



A car in the assembly line.

Note : This picture is given as additional information and is not a direct example of the current chapter.

when $\theta = 0^\circ$, *i.e.* when the roller is at the beginning of its lift along the straight flank (or when the roller has contact with the straight flank at E).

∴ Minimum acceleration of the follower,

$$a_{min} = \omega^2 (r_1 + r_2)$$

The acceleration is maximum when $\theta = \phi$, *i.e.* when the roller just leaves contact with the straight flank at G or when the straight flank merges into a circular nose.

∴ Maximum acceleration of the follower,

$$a_{max} = \omega^2 (r_1 + r_2) \left(\frac{2 - \cos^2 \phi}{\cos^3 \phi} \right)$$

2. When the roller has contact with the nose. A roller having contact with the circular nose at G is shown in Fig 20.41. The centre of roller lies at D on the pitch curve. The displacement is usually measured from the top position of the roller, *i.e.* when the roller has contact at the apex of the nose (point H) and the centre of roller lies at J on the pitch curve.

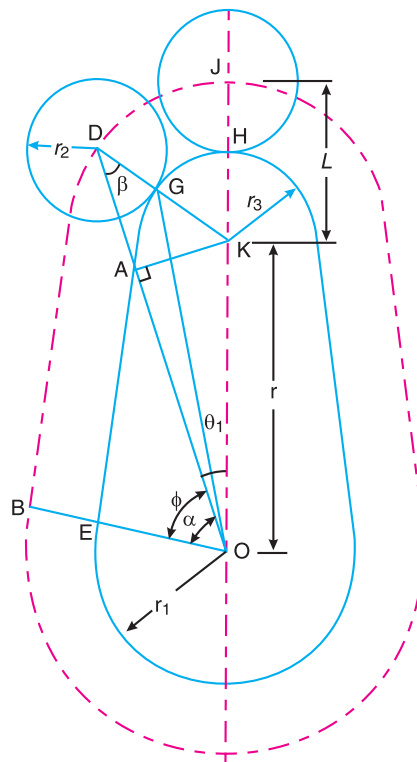

Fig. 20.41. Tangent cam with reciprocating roller follower having contact with the nose.

Let θ_1 = Angle turned by the cam measured from the position when the roller is at the top of the nose.

812 • Theory of Machines

The displacement of the roller is given by

$$x = OJ - OD = OJ - (OA + AD) = (OK + KJ) - (OA + AD)$$

Substituting $OK = r$ and $KJ = KH + HJ = r_3 + r_2 = L$, we have

$$\begin{aligned} x &= (r + L) - (OK \times \cos \theta_1 + DK \cos \beta) \\ &= (r + L) - (r \cos \theta_1 + L \cos \beta) \quad \dots (\because DK = KJ = r_3 + r_2 = L) \\ &= L + r - r \cos \theta_1 - L \cos \beta \quad \dots (i) \end{aligned}$$

Now from right angled triangles OAK and DAK ,

$$AK = DK \sin \beta = OK \sin \theta_1$$

or $L \sin \beta = r \sin \theta_1$

Squaring both sides,

$$L^2 \sin^2 \beta = r^2 \sin^2 \theta_1 \text{ or } L^2 (1 - \cos^2 \beta) = r^2 \sin^2 \theta_1$$

$$L^2 - L^2 \cos^2 \beta = r^2 \sin^2 \theta_1 \text{ or } L^2 \cos^2 \beta = L^2 - r^2 \sin^2 \theta_1$$

$$\therefore L \cos \beta = (L^2 - r^2 \sin^2 \theta_1)^{\frac{1}{2}}$$

Substituting the value of $L \cos \beta$ in equation (i), we get

$$x = L + r - r \cos \theta_1 - (L^2 - r^2 \sin^2 \theta_1)^{\frac{1}{2}} \quad \dots (ii)$$

Differentiating equation (ii) with respect to t , we have velocity of the follower,

$$\begin{aligned} v &= \frac{dx}{dt} = \frac{dx}{d\theta_1} \times \frac{d\theta_1}{dt} \\ &= -r \times -\sin \theta_1 \times \frac{d\theta_1}{dt} - \frac{1}{2} (L^2 - r^2 \sin^2 \theta_1)^{-\frac{1}{2}} (-r^2 \times 2 \sin \theta_1 \cos \theta_1) \frac{d\theta_1}{dt} \\ &= r \sin \theta_1 \times \frac{d\theta_1}{dt} + \frac{1}{2} (L^2 - r^2 \sin^2 \theta_1)^{-\frac{1}{2}} r^2 \times \sin 2\theta_1 \times \frac{d\theta_1}{dt} \\ &= \omega \cdot r \left[\sin \theta_1 + \frac{r \sin 2\theta_1}{2(L^2 - r^2 \sin^2 \theta_1)^{\frac{1}{2}}} \right] \quad \dots \left(\text{Substituting } \frac{d\theta_1}{dt} = \omega \right) \dots (iii) \end{aligned}$$

Now differentiating equation (iii) with respect to t , we have acceleration of the follower,

$$\begin{aligned} a &= \frac{dv}{dt} = \frac{dv}{d\theta_1} \times \frac{d\theta_1}{dt} \\ &= \omega \cdot r \left[\cos \theta_1 + \frac{r \sin 2\theta_1 \times \frac{1}{2} (L^2 - r^2 \sin^2 \theta_1)^{-\frac{1}{2}} (r^2 \times 2 \sin \theta_1 \cos \theta_1) + (L^2 - r^2 \sin^2 \theta_1)^{\frac{1}{2}} (r \times 2 \cos 2\theta_1)}{2(L^2 - r^2 \sin^2 \theta_1)} \right] \frac{d\theta_1}{dt} \end{aligned}$$

Substituting $\frac{d\theta_1}{dt} = \omega$ and multiplying the numerator and denominator of second term by $(L^2 - r^2 \sin^2 \theta_1)^{\frac{1}{2}}$, we have

$$\begin{aligned} a &= \omega^2 \cdot r \left[\cos \theta_1 + \frac{(L^2 - r^2 \sin^2 \theta_1)(2r \cos 2\theta_1) + \frac{1}{2} \times r^3 \sin^2 2\theta_1}{2(L^2 - r^2 \sin^2 \theta_1)^{3/2}} \right] \\ &= \omega^2 \cdot r \left[\cos \theta_1 + \frac{L^2 \times 2r \cos 2\theta_1 - 2r^3 \sin^2 \theta_1 \cdot \cos 2\theta_1 + \frac{1}{2} \times r^3 (2 \sin \theta_1 \cos \theta_1)^2}{2(L^2 - r^2 \sin^2 \theta_1)^{3/2}} \right] \\ &= \omega^2 \cdot r \left[\cos \theta_1 + \frac{2L^2 \cdot r \cos 2\theta_1 - 2r^3 \cdot \sin^2 \theta_1 (1 - 2 \sin^2 \theta_1) + 2r^3 \sin^2 \theta_1 (1 - \sin^2 \theta_1)}{2(L^2 - r^2 \sin^2 \theta_1)^{3/2}} \right] \\ &= \omega^2 \cdot r \left[\cos \theta_1 + \frac{L^2 \cdot r \cos 2\theta_1 + r^3 \sin^4 \theta_1}{(L^2 - r^2 \sin^2 \theta_1)^{3/2}} \right] \end{aligned}$$

Notes : 1. Since θ_1 is measured from the top position of the roller, therefore for the roller to have contact at the apex of the nose (i.e. at point H), then $\theta_1 = 0$, and for the roller to have contact where straight flank merges into a nose (i.e. at point G), then $\theta_1 = \alpha - \phi$.

2. The velocity is zero at H and maximum at G.

3. The acceleration is minimum at H and maximum at G.

4. From Fig 20.41, we see that the distances OK and KD remains constant for all positions of the roller when it moves along the circular nose. In other words, a tangent cam operating a roller follower and having contact with the nose is equivalent to a slider crank mechanism (i.e. ODK) in which the roller is assumed equivalent to the slider D, crank OK and connecting rod DK. Therefore the velocity and acceleration of the roller follower may be obtained graphically as discussed in Chapters 7 and 8.

Example 20.13. In a symmetrical tangent cam operating a roller follower, the least radius of the cam is 30 mm and roller radius is 17.5 mm. The angle of ascent is 75° and the total lift is 17.5 mm. The speed of the cam shaft is 600 r.p.m. Calculate : **1.** the principal dimensions of the cam ; **2.** the accelerations of the follower at the beginning of the lift, where straight flank merges into the circular nose and at the apex of the circular nose. Assume that there is no dwell between ascent and descent.

Solution. Given : $r_1 = 30$ mm ; $r_2 = 17.5$ mm ;
 $\alpha = 75^\circ$; Total lift = 17.5 mm ; $N = 600$ r.p.m. or
 $\omega = 2\pi \times 600/60 = 62.84$ rad/s

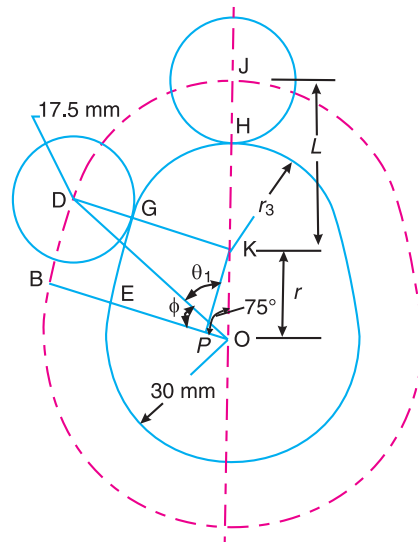

Fig. 20.42

814 • Theory of Machines

1. Principal dimensions of the cam

Let $r = OK$ = Distance between cam centre and nose centre,
 r_3 = Nose radius, and
 ϕ = Angle of contact of cam with straight flanks.

From the geometry of Fig. 20.42,

$$\begin{aligned} r + r_3 &= r_1 + \text{Total lift} \\ &= 30 + 17.5 = 47.5 \text{ mm} \end{aligned}$$

$$\therefore r = 47.5 - r_3 \quad \dots (i)$$

Also, $OE = OP + PE$ or $r_1 = OP + r_3$

$$\therefore OP = r_1 - r_3 = 30 - r_3 \quad \dots (ii)$$

Now from right angled triangle OKP ,

$$OP = OK \times \cos \alpha \quad \dots (\because \cos \alpha = OP / OK)$$

$$\begin{aligned} \text{or} \quad 30 - r_3 &= (47.5 - r_3) \cos 75^\circ = (47.5 - r_3) 0.2588 = 12.3 - 0.2588 r_3 \\ &\dots (\because OK = r) \end{aligned}$$

$$\therefore r_3 = 23.88 \text{ mm Ans.}$$

$$\text{and} \quad r = OK = 47.5 - r_3 = 47.5 - 23.88 = 23.62 \text{ mm Ans.}$$

Again, from right angled triangle ODB ,

$$\tan \phi = \frac{DB}{OB} = \frac{KP}{OB} = \frac{OK \sin \alpha}{r_1 + r_2} = \frac{23.62 \sin 75^\circ}{30 + 17.5} = 0.4803$$

$$\therefore \phi = 25.6^\circ \text{ Ans.}$$

2. Acceleration of the follower at the beginning of the lift

We know that acceleration of the follower at the beginning of the lift, *i.e.* when the roller has contact at E on the straight flank,

$$\begin{aligned} a_{min} &= \omega^2 (r_1 + r_2) = (62.84)^2 (30 + 17.5)^2 = 187\,600 \text{ mm/s}^2 \\ &= 187.6 \text{ m/s}^2 \text{ Ans.} \end{aligned}$$

Acceleration of the follower where straight flank merges into a circular nose

We know that acceleration of the follower where straight flank merges into a circular nose *i.e.* when the roller just leaves contact at G ,

$$\begin{aligned} a_{max} &= \omega^2 (r_1 + r_2) \left[\frac{2 - \cos^2 \phi}{\cos^3 \phi} \right] = (62.84)^2 (30 + 17.5) \left(\frac{2 - \cos^2 25.6^\circ}{\cos^3 25.6^\circ} \right) \\ &= 187\,600 \left(\frac{2 - 0.813}{0.733} \right) = 303\,800 \text{ mm/s}^2 = 303.8 \text{ m/s}^2 \text{ Ans.} \end{aligned}$$

Acceleration of the follower at the apex of the circular nose

We know that acceleration of the follower for contact with the circular nose,

$$a = \omega^2 \cdot r \left[\cos \theta_1 + \frac{L^2 \cdot r \cos 2\theta_1 + r^3 \sin^4 \theta_1}{(L^2 - r^2 \sin^2 \theta_1)^{3/2}} \right]$$

Since θ_1 is measured from the top position of the follower, therefore for the follower to have contact at the apex of the circular nose (*i.e.* at point H), $\theta_1 = 0$.

∴ Acceleration of the follower at the apex of the circular nose,

$$\begin{aligned} a &= \omega^2 \cdot r \left(1 + \frac{L^2 \cdot r}{L^3} \right) = \omega^2 \cdot r \left(1 + \frac{r}{L} \right) = \omega^2 \cdot r \left(1 + \frac{r}{r_2 + r_3} \right) \\ &= (62.84)^2 \cdot 23.62 \left(1 + \frac{23.62}{17.5 + 23.88} \right) = 146\,530 \text{ mm/s}^2 \quad \dots (\because L = r_2 + r_3) \\ &= 146.53 \text{ m/s}^2 \text{ Ans.} \end{aligned}$$

Example 20.14. A cam has straight working faces which are tangential to a base circle of diameter 90 mm. The follower is a roller of diameter 40 mm and the centre of roller moves along a straight line passing through the centre line of the cam shaft. The angle between the tangential faces of the cam is 90° and the faces are joined by a nose circle of 10 mm radius. The speed of rotation of the cam is 120 revolutions per min.

Find the acceleration of the roller centre **1.** when during the lift, the roller is just about to leave the straight flank ; and **2.** when the roller is at the outer end of its lift.

Solution. Given : $d_1 = 90 \text{ mm}$ or $r_1 = 45 \text{ mm}$; $d_2 = 40 \text{ mm}$ or $r_2 = 20 \text{ mm}$; $2 \alpha = 90^\circ$ or $\alpha = 45^\circ$; $r_3 = 10 \text{ mm}$; $N = 120 \text{ r.p.m.}$ or $\omega = 2\pi \times 120/60 = 12.57 \text{ rad/s}$

The tangent cam operating a roller follower is shown in Fig. 20.43.

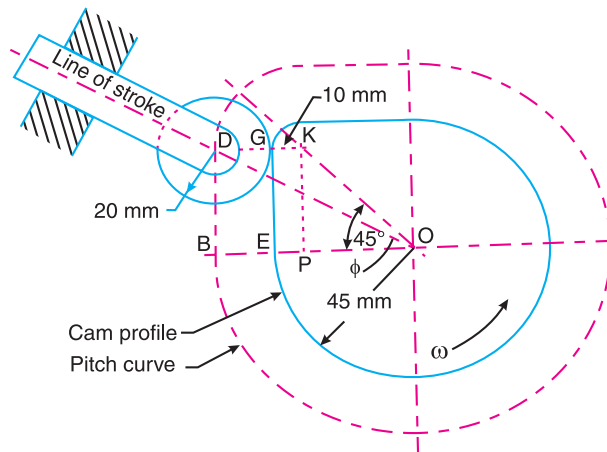

Fig. 20.43

First of all, let us find the *angle turned by the cam (ϕ) when the roller is just about to leave the straight flank at G . The centre of roller at this position lies at D .

* Since the cam is assumed to be stationary, ϕ is the angle turned by the roller when it is just about to leave the straight flank at G .

816 • Theory of Machines

From the geometry of the figure,

$$\begin{aligned} BD &= PK = OP = OE - PE \\ &= OE - KG \\ &= r_1 - r_3 = 45 - 10 = 35 \text{ mm} \end{aligned}$$

Now from triangle OBD ,

$$\begin{aligned} \tan \phi &= \frac{BD}{OB} = \frac{BD}{OE + EB} \\ &= \frac{BD}{r_1 + r_2} = \frac{35}{45 + 20} = 0.5385 \end{aligned}$$

$$\therefore \phi = 28.3^\circ$$



In aircraft engines roller followers are widely used.

1. Acceleration of the roller centre when roller is just about to leave the straight flank

We know that acceleration of the roller centre when the roller is just about to leave the straight flank,

$$\begin{aligned} a &= \omega^2 (r_1 + r_2) \left(\frac{2 - \cos^2 \phi}{\cos^3 \phi} \right) = (12.57)^2 (45 + 20) \left(\frac{2 - \cos^2 28.3^\circ}{\cos^3 28.3^\circ} \right) \\ &= 18\,500 \text{ mm/s}^2 = 18.5 \text{ m/s}^2 \text{ Ans.} \end{aligned}$$

2. Acceleration of the roller centre when the roller is at the outer end of the lift

First of all, let us find the values of OK and KD . From the geometry of the figure,

$$OK = r = \sqrt{(OP)^2 + (PK)^2} = \sqrt{2} \times OP \quad \dots (\because OP = PK)$$

$$= \sqrt{2}(OE - EP) = \sqrt{2}(45 - 10) = 49.5 \text{ mm}$$

$$KD = L = KG + GD = r_3 + r_2 = 10 + 20 = 30 \text{ mm}$$

We know that acceleration of the roller centre when the roller is at the outer end of the lift, *i.e.* when the roller has contact at the top of the nose,

$$a = \omega^2 \cdot r \left[\cos \theta_1 + \frac{L^2 \cdot r \cos 2\theta_1 + r^3 \sin^4 \theta_1}{(L^2 - r^2 \sin^2 \theta_1)^{3/2}} \right] = \omega^2 \cdot r \left(1 + \frac{r}{L} \right)$$

$\dots (\because \text{At the outer end of the lift, } \theta_1 = 0)$

$$= (12.57)^2 49.5 \left(1 + \frac{49.5}{30} \right) = 20\,730 \text{ mm/s}^2 = 20.73 \text{ m/s}^2 \text{ Ans.}$$

20.13. Circular Arc Cam with Flat-faced Follower

When the flanks of the cam connecting the base circle and nose are of convex circular arcs, then the cam is known as **circular arc cam**. A symmetrical circular arc cam operating a flat-faced follower is shown in Fig. 20.44, in which O and Q are the centres of cam and nose respectively. EF and GH are two circular flanks whose centres lie at P and P' respectively. The centres * P and P'

* The centres P and P' may also be obtained by drawing arcs with centres O and Q and radii equal to OP and PQ respectively. The circular flanks EF and GH are now drawn with centres P and P' and radius equal to PE .

lie on lines EO and GO produced.

- Let
- r_1 = Minimum radius of the cam or radius of the base circle = OE ,
 - r_2 = Radius of nose,
 - R = Radius of circular flank = PE ,
 - 2α = Total angle of action of cam = angle EOG ,
 - α = Semi-angle of action of cam or angle of ascent = angle EOK , and
 - ϕ = Angle of action of cam on the circular flank.

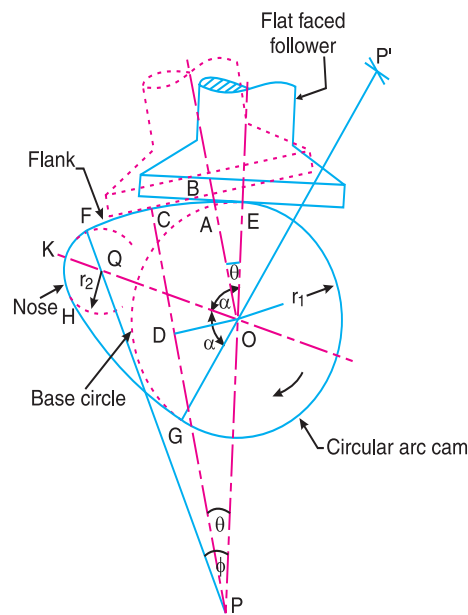

Fig. 20.44. Circular arc cam with flat face of the follower having contact with the circular flank.

We shall consider the following two cases :

1. When the flat face of the follower has contact on the circular flank, and
2. When the flat face of the follower has contact on the nose.

In deriving the expressions for displacement, velocity and acceleration of the follower for the above two cases, it is assumed that the cam is fixed and the follower rotates in the opposite sense to that of the cam. In Fig. 20.44, the cam is rotating in the clockwise direction and the follower rotates in the counter-clockwise direction.

1. When the flat face of the follower has contact on the circular flank. First of all, let us consider that the flat face of the follower has contact at E (i.e. at the junction of the circular flank and base circle). When the cam turns through an angle θ (less than ϕ) relative to the follower, the contact of the flat face of the follower will shift from E to C on the circular flank, such that flat face of the follower is perpendicular to PC . Since OB is perpendicular to BC , therefore OB is parallel to PC . From O , draw OD perpendicular to PC .

From the geometry of the figure, the displacement or lift of the follower (x) at any instant for contact on the circular flank, is given by

$$x = BA = BO - AO = CD - EO \quad \dots (i)$$

We know that

$$\begin{aligned} CD &= PC - PD = PE - OP \cos \theta \\ &= OP + OE - OP \cos \theta = OE + OP(1 - \cos \theta) \end{aligned}$$

818 • Theory of Machines

Substituting the value of CD in equation (i),

$$\begin{aligned} x &= OE + OP(1 - \cos \theta) - EO = OP(1 - \cos \theta) \\ &= (PE - OE)(1 - \cos \theta) = (R - r_1)(1 - \cos \theta) \end{aligned} \quad \dots \text{(ii)}$$

Differentiating equation (ii) with respect to t , we have velocity of the follower,

$$\begin{aligned} v &= \frac{dx}{dt} = \frac{dx}{d\theta} \times \frac{d\theta}{dt} = \frac{dx}{d\theta} \times \omega \quad \dots \left(\text{substituting } \frac{d\theta}{dt} = \omega \right) \\ &= (R - r_1) \sin \theta \times \omega = \omega(R - r_1) \sin \theta \end{aligned} \quad \dots \text{(iii)}$$

From the above expression, we see that at the beginning of the ascent (*i.e.* when $\theta = 0$), the velocity is zero (because $\sin 0 = 0$) and it increases as θ increases. The velocity will be maximum when $\theta = \phi$, *i.e.* when the contact of the follower just shifts from circular flank to circular nose. Therefore maximum velocity of the follower,

$$v_{max} = \omega(R - r_1) \sin \phi$$

Now differentiating equation (iii) with respect to t , we have acceleration of the follower,

$$\begin{aligned} a &= \frac{dv}{dt} = \frac{dv}{d\theta} \times \frac{d\theta}{dt} = \frac{dv}{d\theta} \times \omega \\ &= \omega(R - r_1) \cos \theta \times \omega = \omega^2 (R - r_1) \cos \theta \end{aligned} \quad \dots \text{(iv)}$$

From the above expression, we see that at the beginning of the ascent (*i.e.* when $\theta = 0$), the acceleration is maximum (because $\cos 0 = 1$) and it decreases as θ increases. The acceleration will be minimum when $\theta = \phi$.

\therefore Maximum acceleration of the follower,

$$a_{max} = \omega^2 (R - r_1)$$

and minimum acceleration of the follower,

$$a_{min} = \omega^2 (R - r_1) \cos \phi$$

2. When the flat face of the follower has contact on the nose. The flat face of the follower having contact on the nose at C is shown in Fig. 20.45. The centre of curvature of the nose lies at Q . In this case, the displacement or lift of the follower at any instant when the cam has turned through an angle θ (greater than ϕ) is given by

$$x = AB = OB - OA = CD - OA \quad \dots (\because OB = CD) \dots \text{(i)}$$

But $CD = CQ + QD = CQ + OQ \cos(\alpha - \theta)$

Substituting the value of CD in equation (i), we have

$$x = CQ + OQ \cos(\alpha - \theta) - OA \quad \dots \text{(ii)}$$

The displacement or lift of the follower when the contact is at the apex K of the nose *i.e.* when $\alpha - \theta = 0$ is

$$* x = CQ + OQ - OA = r_2 + OQ - r_1$$

* From the geometry of Fig. 20.45, we also find that lift of the follower when the contact is at the apex K of the nose is

$$x = JK = OQ + QK - OJ = OQ + r_2 - r_1$$

Differentiating equation (ii) with respect to t , we have velocity of the follower,

$$v = \frac{dx}{dt} = \frac{dx}{d\theta} \times \frac{d\theta}{dt} = \frac{dx}{d\theta} \times \omega$$

$$= OQ \sin(\alpha - \theta) \omega = \omega \times OQ \sin(\alpha - \theta) \quad \dots (iii)$$

... (∵ CQ, OQ, OA and α are constant)

From the above expression, we see that the velocity is zero when $\alpha - \theta = 0$ or $\alpha = \theta$ i.e. when the follower is at the apex K of the nose. The velocity will be maximum when $(\alpha - \theta)$ is maximum. This happens when the follower changes contact from circular flank to circular nose at point F , i.e. when $(\alpha - \theta) = \phi$.

Now differentiating equation (iii) with respect to t , we have acceleration of the follower,

$$a = \frac{dv}{dt} = \frac{dv}{d\theta} \times \frac{d\theta}{dt} = \frac{dv}{d\theta} \times \omega$$

$$= -\omega \times OQ \cos(\alpha - \theta) \omega = -\omega^2 \times OQ \cos(\alpha - \theta) \quad \dots (iv)$$

The negative sign in the above expression shows that there is a retardation when the follower is in contact with the nose of the cam.

From the above expression, we see that retardation is maximum when $\alpha - \theta = 0$ or $\theta = \alpha$, i.e. when the follower is at the apex K of the nose.

∴ Maximum retardation = $\omega^2 \times OQ$

The retardation is minimum when $\alpha - \theta$ is maximum. This happens when the follower changes contact from circular flank to circular nose at point F i.e. when $\theta = \phi$.

∴ Minimum retardation = $\omega^2 \times OQ \cos(\alpha - \phi)$

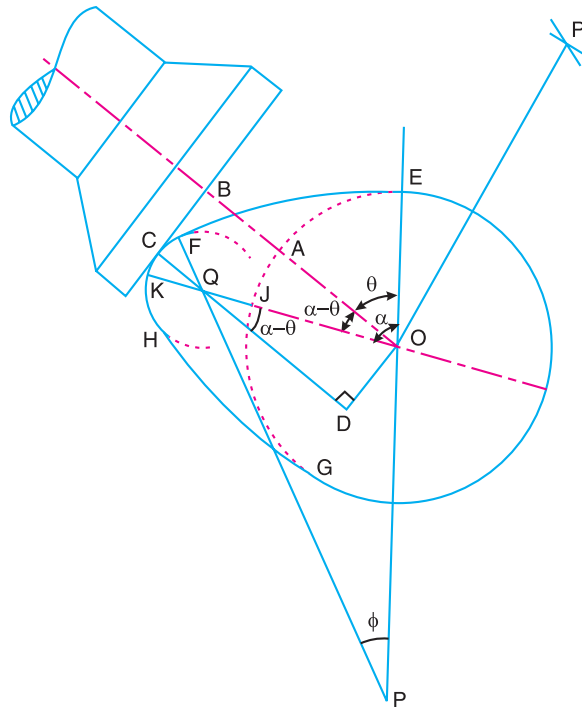

Fig. 20.45. Circular arc cam with flat face of the follower having contact on the nose.

Example 20.15. A symmetrical circular cam operating a flat-faced follower has the following particulars :

Minimum radius of the cam = 30 mm ; Total lift = 20 mm ; Angle of lift = 75° ; Nose radius = 5 mm ; Speed = 600 r.p.m. Find : **1.** the principal dimensions of the cam, and **2.** the acceleration of the follower at the beginning of the lift, at the end of contact with the circular flank , at the beginning of contact with nose and at the apex of the nose.

Solution. Given : $r_1 = OE = 30$ mm ; $x = JK = 20$ mm ; $\alpha = 75^\circ$; $r_2 = QF = QK = 5$ mm ; $N = 600$ r.p.m. or $\omega = 2\pi \times 600 / 60 = 62.84$ rad/s

1. Principal dimensions of the cam

A symmetrical circular cam operating a flat faced follower is shown in Fig. 20.46.

Let $OQ =$ Distance between cam centre and nose centre,

$R = PE =$ Radius of circular flank, and

$\phi =$ Angle of contact on the circular flank.

We know that lift of the follower (x),

$$20 = OQ + r_2 - r_1 = OQ + 5 - 30 = OQ - 25$$

$$\therefore OQ = 20 + 25 = 45 \text{ mm Ans.}$$

We know that $PQ = PF - FQ = PE - FQ = OP + OE - FQ$

$$= OP + 30 - 5 = (OP + 25) \text{ mm}$$

Now from a triangle OPQ ,

$$(PQ)^2 = (OP)^2 + (OQ)^2 - 2 \times OP \times OQ \cos \beta$$

$$(OP + 25)^2 = (OP)^2 + 45^2 - 2 \times OP \times 45 \cos (180^\circ - 75^\circ)$$

$$(OP)^2 + 50OP + 625 = (OP)^2 + 2025 + 23.3OP$$

$$50OP - 23.3OP = 2025 - 625$$

$$\text{or } 26.7OP = 1400$$

$$\text{and } OP = 1400 / 26.7 = 52.4 \text{ mm}$$

\therefore Radius of circular flanks,

$$R = PE = OP + OE = 52.4 + 30 = 82.4 \text{ mm Ans.}$$

$$\text{and } PQ = OP + 25 = 52.4 + 25$$

$$= 77.4 \text{ mm Ans.}$$

In order to find angle ϕ , consider a triangle OPQ . We know that

$$\frac{OQ}{\sin \phi} = \frac{PQ}{\sin \beta}$$

$$\text{or } \sin \phi = \frac{OQ \times \sin \beta}{PQ} = \frac{45 \times \sin (180^\circ - 75^\circ)}{77.4} = 0.5616$$

$$\therefore \phi = 34.2^\circ \text{ Ans.}$$

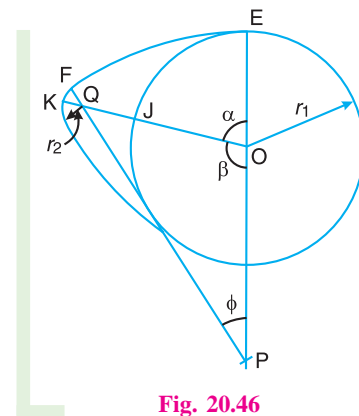

Fig. 20.46

2. Acceleration of the follower

We know that acceleration of the follower at the beginning of the lift,

$$\begin{aligned} a &= \omega^2 (R - r_1) \cos \theta = \omega^2 (R - r_1) \quad \dots (\because \text{At the beginning of lift, } \theta = 0^\circ) \\ &= (62.84)^2 (82.4 - 30) = 206\,930 \text{ mm/s}^2 = 206.93 \text{ m/s}^2 \text{ Ans.} \end{aligned}$$

Acceleration of the follower at the end of contact with the circular flank,

$$\begin{aligned} a &= \omega^2 (R - r_1) \cos \theta = \omega^2 (R - r_1) \cos \phi \\ &\dots (\because \text{At the end of contact with the circular flank, } \theta = \phi) \\ &= - (62.84)^2 (82.4 - 30) \cos 34.2^\circ = 171\,130 \text{ mm/s}^2 = 171.13 \text{ m/s}^2 \text{ Ans.} \end{aligned}$$

Acceleration of the follower at the beginning of contact with nose,

$$\begin{aligned} a &= -\omega^2 \times OQ \cos (\alpha - \theta) = -\omega^2 \times OQ \cos (\alpha - \phi) \\ &\dots (\because \text{At the beginning of contact with nose, } \theta = \phi) \\ &= - (62.84)^2 45 \cos (75^\circ - 34.2^\circ) = -134\,520 \text{ mm/s}^2 = -134.52 \text{ m/s}^2 \\ &= 134.52 \text{ m/s}^2 \text{ (Retardation) Ans.} \end{aligned}$$

and acceleration of the follower at the apex of nose,

$$\begin{aligned} a &= -\omega^2 \times OQ \cos (\alpha - \theta) = -\omega^2 \times OQ \quad \dots (\because \text{At the apex of nose, } \alpha - \theta = 0) \\ &= - (62.84)^2 45 = -177\,700 \text{ mm/s}^2 = -177.7 \text{ m/s}^2 \\ &= 177.7 \text{ m/s}^2 \text{ (Retardation) Ans.} \end{aligned}$$

Example 20.16. A symmetrical cam with convex flanks operates a flat-footed follower. The lift is 8 mm, base circle radius 25 mm and the nose radius 12 mm. The total angle of the cam action is 120° .

1. Find the radius of convex flanks, **2.** Draw the profile of the cam, and **3.** Determine the maximum velocity and the maximum acceleration when the cam shaft rotates at 500 r.p.m.

Solution. Given : $x = JK = 8 \text{ mm}$; $r_1 = OE = OJ = 25 \text{ mm}$; $r_2 = QF = QK = 12 \text{ mm}$; $2\alpha = \angle EOG = 120^\circ$ or $\alpha = \angle EOK = 60^\circ$; $N = 500 \text{ r.p.m.}$ or $\omega = 2\pi \times 500/60 = 52.37 \text{ rad/s}$

1. Radius of convex flanks

Let $R = \text{Radius of convex flanks} = PE = P'G$

A symmetrical cam with convex flanks operating a flat footed follower is shown in Fig. 20.47. From the geometry of the figure,

$$\begin{aligned} OQ &= OJ + JK - QK = r_1 + x - r_2 \\ &= 25 + 8 - 12 = 21 \text{ mm} \end{aligned}$$

$$PQ = PF - QF = PE - QF = (R - 12) \text{ mm}$$

and $OP = PE - OE = (R - 25) \text{ mm}$

822 • Theory of Machines

Now consider the triangle OPQ . We know that

$$(PQ)^2 = (OP)^2 + (OQ)^2 - 2OP \times OQ \times \cos \beta$$

$$(R-12)^2 = (R-25)^2 + (21)^2 - 2(R-25)21 \cos(180^\circ - 60^\circ)$$

$$R^2 - 24R + 144 = R^2 - 50R + 625 + 441 + 21R - 525$$

$$-24R + 144 = -29R + 541 \text{ or } 5R = 397$$

$$\therefore R = 397/5 = 79.4 \text{ mm Ans.}$$

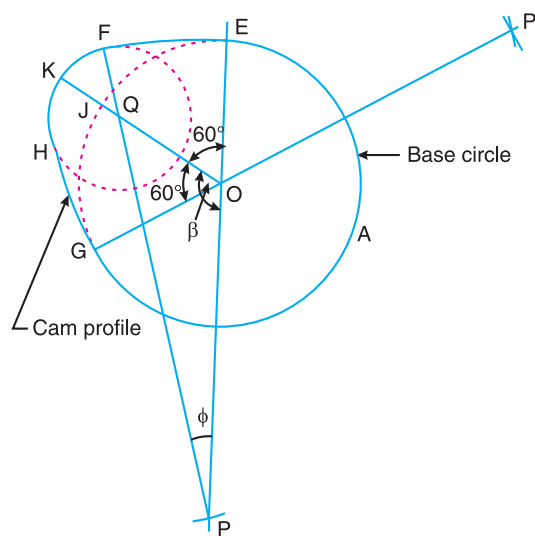

Fig. 20.47

2. Profile of the cam

The profile of the cam, as shown in Fig. 20.47, is drawn as discussed in the following steps :

- First of all, draw a base circle with centre O and radius $OE = r_1 = 25$ mm.
- Draw angle $EOK = 60^\circ$ and angle $KOG = 60^\circ$ such that the total angle of cam action is 120° .
- On line OK mark $OQ = 21$ mm (as calculated above). Now Q as centre, draw a circle of radius equal to the nose radius $r_2 = QK = QF = 12$ mm. This circle cuts the line OK at J . Now JK represents the lift of the follower (*i.e.* 8 mm).
- Produce EO and GO as shown in Fig. 20.47. Now with Q as centre and radius equal to $PQ = R - r_2 = 79.4 - 12 = 67.4$ mm, draw arcs intersecting the lines EO and GO produced at P and P' respectively. The centre P' may also be obtained by drawing arcs with centres O and Q and radii OP and PQ respectively.
- Now with P and P' as centres and radius equal to $R = 79.4$ mm, draw arcs EF and GH which represent the convex flanks. $EFKHGAE$ is the profile of the cam.

3. Maximum velocity and maximum acceleration

First of all, let us find the angle ϕ . From triangle OPQ ,

$$\frac{OQ}{\sin \phi} = \frac{PQ}{\sin \beta}$$

$$\text{or } \sin \phi = \frac{OQ}{PQ} \times \sin \beta = \frac{21}{79.4 - 12} \times \sin (180^\circ - 60^\circ) = 0.2698$$

$$\dots (\because PQ = R - 12)$$

$$\therefore \phi = 15.65^\circ$$

We know that maximum velocity,

$$v_{max} = \omega(R - r_1) \sin \phi = 52.37(79.4 - 25) \sin 15.65^\circ = 770 \text{ mm/s}$$

$$= 0.77 \text{ m/s Ans.}$$

and maximum acceleration,

$$a_{max} = \omega^2 (R - r_1) = (52.37)^2 (79.4 - 25) = 149200 \text{ mm/s}^2 = 149.2 \text{ m/s}^2 \text{ Ans.}$$

Example 20.17. The following particulars relate to a symmetrical circular cam operating a flat faced follower :

Least radius = 16 mm, nose radius = 3.2 mm, distance between cam shaft centre and nose centre = 25 mm, angle of action of cam = 150° , and cam shaft speed = 600 r.p.m.

Assuming that there is no dwell between ascent or descent, determine the lift of the valve, the flank radius and the acceleration and retardation of the follower at a point where circular nose merges into circular flank.

Solution. Given : $r_1 = OE = OJ = 16 \text{ mm}$; $r_2 = QK = QF = 3.2 \text{ mm}$; $OQ = 25 \text{ mm}$; $2\alpha = 150^\circ$ or $\alpha = 75^\circ$; $N = 600 \text{ r.p.m.}$ or $\omega = 2\pi \times 600/60 = 62.84 \text{ rad/s}$

Lift of the valve

A symmetrical circular cam operating a flat faced follower is shown in Fig. 20.48.

We know that lift of the valve,

$$x = JK = OK - OJ$$

$$= OQ + QK - OJ = OQ + r_2 - r_1$$

$$= 25 + 3.2 - 16 = 12.2 \text{ mm Ans.}$$

Flank radius

Let $R = PE =$ Flank radius.

First of all, let us find out the values of OP and PQ . From the geometry of Fig. 20.48,

$$OP = PE - OE = R - 16$$

and $PQ = PF - FQ = R - 3.2$

Now consider the triangle OPQ . We know that

$$(PQ)^2 = (OP)^2 + (OQ)^2 - 2OP \times OQ \times \cos \beta$$

Substituting the values of OP and PQ in the above expression,

$$(R - 3.2)^2 = (R - 16)^2 + (25)^2 - 2(R - 16) \times 25 \cos (180^\circ - 75^\circ)$$

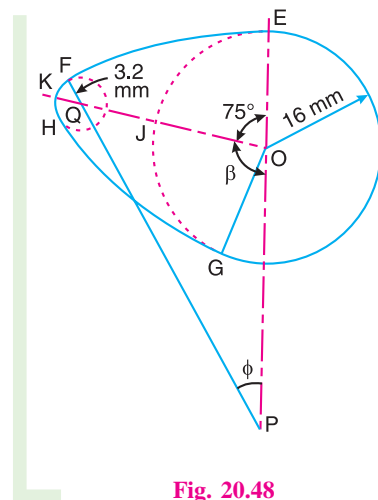

Fig. 20.48

824 • Theory of Machines

$$R^2 - 6.4R + 10.24 = R^2 - 32R + 256 + 625 - (50R - 800)(-0.2588)$$

$$-6.4R + 10.24 = -19.06R + 673.96 \quad \text{or} \quad 12.66R = 663.72$$

$$\therefore R = 52.43 \text{ mm Ans.}$$

Acceleration and retardation of the follower at a point where circular nose merges into circular flank

From Fig. 20.48 we see that at a point F , the circular nose merges into a circular flank. Let ϕ be the angle of action of cam at point F . From triangle OPQ ,

$$\frac{OQ}{\sin \phi} = \frac{PQ}{\sin \beta}$$

or

$$\begin{aligned} \sin \phi &= \frac{OQ}{PQ} \times \sin(180^\circ - 75^\circ) = \frac{OQ}{PF - FQ} \times \sin 105^\circ \\ &= \frac{25}{52.43 - 3.2} \times 0.966 = 0.4907 \end{aligned}$$

$$\therefore \phi = 29.4^\circ$$

We know that acceleration of the follower,

$$\begin{aligned} a &= \omega^2 \times OP \times \cos \theta = \omega^2 (R - r_1) \cos \phi \quad \dots (\because \theta = \phi) \\ &= (62.84)^2 (52.43 - 16) \cos 29.4^\circ = 125\,330 \text{ mm/s}^2 \\ &= 125.33 \text{ m/s}^2 \text{ Ans.} \end{aligned}$$

We also know that retardation of the follower,

$$\begin{aligned} a &= \omega^2 \times OQ \cos(\alpha - \theta) = \omega^2 \times OQ \cos(\alpha - \phi) \quad \dots (\because \theta = \phi) \\ &= (62.84)^2 25 \cos(75^\circ - 29.4^\circ) = 69\,110 \text{ mm/s}^2 \\ &= 69.11 \text{ m/s}^2 \text{ Ans.} \end{aligned}$$

Example 20.18. A flat ended valve tappet is operated by a symmetrical cam with circular arc for flank and nose. The straight line path of the tappet passes through the cam axis. Total angle of action = 150° . Lift = 6 mm. Base circle diameter = 30 mm. Period of acceleration is half the period of retardation during the lift. The cam rotates at 1250 r.p.m. Find : 1. flank and nose radii ; 2. maximum acceleration and retardation during the lift.

Solution. Given : $2\alpha = 150^\circ$ or $\alpha = 75^\circ$; $x = JK = 6 \text{ mm}$;
 $d_1 = 30 \text{ mm}$ or $r_1 = OE = OJ = 15 \text{ mm}$; $N = 1250 \text{ r.p.m.}$ or
 $\omega = 2\pi \times 1250/60 = 131 \text{ rad/s}$

1. Flank and nose radii

The circular arc cam operating a flat ended valve tappet is shown in Fig. 20.49.

Let $R = PE =$ Flank radius, and
 $r_2 = QF = QK =$ Nose radius.

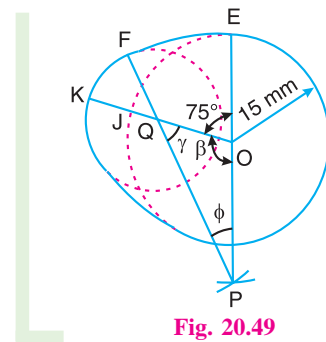

Fig. 20.49

First of all, let us find the values of OP , OQ and PQ . The acceleration takes place while the follower is on the flank and retardation while the follower is on nose. Since the period of acceleration is half the period of retardation during the lift, therefore

$$\phi = \frac{1}{2}\gamma \quad \dots (i)$$

We know that $\beta = 180^\circ - \alpha = 180^\circ - 75^\circ = 105^\circ$

$$\therefore \phi + \gamma = 75^\circ = 180^\circ - \beta = 180^\circ - 105^\circ = 75^\circ \quad \dots (ii)$$

From equations (i) and (ii),

$$\phi = 25^\circ, \quad \text{and} \quad \gamma = 50^\circ$$

Now from the geometry of Fig. 20.49,

$$OQ = OJ + JK - QK = r_1 + x - r_2 = 15 + 6 - r_2 = 21 - r_2 \quad \dots (iii)$$

and $PQ = PF - FQ = PE - FQ = (OP + OE) - FQ = OP + 15 - r_2 \quad \dots (iv)$

Now from triangle OPQ ,

$$\frac{OP}{\sin \gamma} = \frac{OQ}{\sin \phi} = \frac{PQ}{\sin \beta}$$

or $\frac{OP}{\sin 50^\circ} = \frac{21 - r_2}{\sin 25^\circ} = \frac{OP + 15 - r_2}{\sin 105^\circ}$

$$\therefore OP = \frac{21 - r_2}{\sin 25^\circ} \times \sin 50^\circ = \frac{21 - r_2}{0.4226} \times 0.766 = 38 - 1.8 r_2 \quad \dots (v)$$

Also $OP = \frac{OP + 15 - r_2}{\sin 105^\circ} \times \sin 50^\circ = \frac{OP + 15 - r_2}{0.966} \times 0.766$
 $= 0.793 \times OP + 11.9 - 0.793 r_2$

$$\therefore 0.207 OP = 11.9 - 0.793 r_2 \quad \text{or} \quad OP = 57.5 - 3.83 r_2 \quad \dots (vi)$$

From equations (v) and (vi),

$$38 - 1.8 r_2 = 57.5 - 3.83 r_2 \quad \text{or} \quad 2.03 r_2 = 19.5$$

$$\therefore r_2 = 9.6 \text{ mm Ans.}$$

We know that $OP = 38 - 1.8 r_2 = 38 - 1.8 \times 9.6 = 20.7 \text{ mm} \quad \dots$ [From equation (v)]

$$\therefore R = PE = OP + OE = 20.7 + 15 = 35.7 \text{ mm Ans.}$$

2. Maximum acceleration and retardation during the lift

We know that maximum acceleration

$$= \omega^2 (R - r_1) = \omega^2 \times OP = (131)^2 20.7 = 355230 \text{ mm/s}^2$$

$$= 355.23 \text{ m/s}^2 \text{ Ans.}$$

and maximum retardation, $= \omega^2 \times OQ = \omega^2 (21 - r_2) \quad \dots$ [From equation (iii)]

$$= (131)^2 (21 - 9.6) = 195640 \text{ mm/s}^2 = 195.64 \text{ m/s}^2 \text{ Ans.}$$

Example 20.19. A cam consists of a circular disc of diameter 75 mm with its centre displaced 25 mm from the camshaft axis. The follower has a flat surface (horizontal) in contact with the cam and the line of action of the follower is vertical and passes through the shaft axis as shown in Fig. 20.50. The mass of the follower is 2.3 kg and is pressed downwards by a spring which has a stiffness of 3.5 N/mm. In the lowest position the spring force is 45 N.

1. Derive an expression for the acceleration of the follower in terms of the angle of rotation from the beginning of the lift.

2. As the cam shaft speed is gradually increased, a value is reached at which the follower begins to lift from the cam surface. Determine the camshaft speed for this condition.

Solution. Given : $d = 75 \text{ mm}$ or $r = OA = 37.5 \text{ mm}$;
 $OQ = 25 \text{ mm}$; $m = 2.3 \text{ kg}$; $s = 3.5 \text{ N/mm}$; $S = 45 \text{ N}$

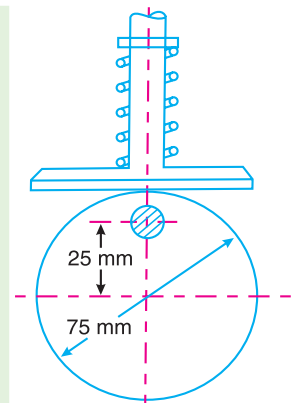

Fig. 20.50

1. Expression for the acceleration of the follower

The cam in its lowest position is shown by full lines in Fig. 20.51 and by dotted lines when it has rotated through an angle θ .

From the geometry of the figure, the displacement of the follower,

$$\begin{aligned} x &= AB = OS = OQ - QS \\ &= OQ - PQ \cos \theta \\ &= OQ - OQ \cos \theta \quad \dots (\because PQ = OQ) \\ &= OQ(1 - \cos \theta) = 25(1 - \cos \theta) \quad \dots (i) \end{aligned}$$

Differentiating equation (i) with respect to t , we get velocity of the follower,

$$\begin{aligned} v &= \frac{dx}{dt} = \frac{dx}{d\theta} \times \frac{d\theta}{dt} = \frac{dx}{d\theta} \times \omega \\ &\dots (\text{Substituting } d\theta/dt = \omega) \\ &= 25 \sin \theta \times \omega = 25 \omega \sin \theta \quad \dots (ii) \end{aligned}$$

Now differentiating equation (ii) with respect to t , we get acceleration of the follower,

$$\begin{aligned} a &= \frac{dv}{dt} = \frac{dv}{d\theta} \times \frac{d\theta}{dt} = 25 \omega \cos \theta \times \omega \\ &= 25 \omega^2 \cos \theta \text{ mm/s}^2 = 0.025 \omega^2 \cos \theta \text{ m/s}^2 \text{ Ans.} \end{aligned}$$

2. Cam shaft speed

Let $N = \text{Cam shaft speed in r.p.m.}$

We know that accelerating force

$$= m.a = 2.3 \times 0.025 \omega^2 \cos \theta = 0.0575 \omega^2 \cos \theta \text{ N}$$

Now for any value of θ , the algebraic sum of the spring force, weight of the follower and the accelerating force is equal to the vertical reaction between the cam and follower. When this reaction is zero, then the follower will just begin to leave the cam.

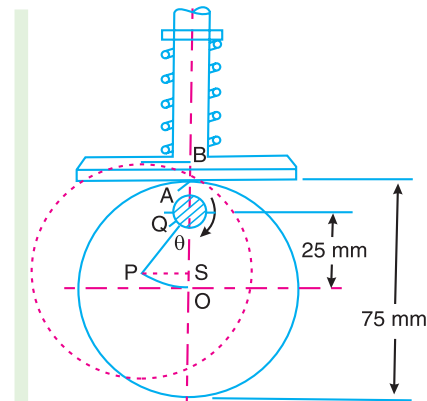

Fig. 20.51

$$\begin{aligned} \therefore S + s.x + m.g + m.a &= 0 \\ 45 + 3.5 \times 25(1 - \cos \theta) + 2.3 \times 9.81 + 0.0575 \omega^2 \cos \theta &= 0 \\ 45 + 87.5 - 87.5 \cos \theta + 22.56 + 0.0575 \omega^2 \cos \theta &= 0 \\ 155.06 - 87.5 \cos \theta + 0.0575 \omega^2 \cos \theta &= 0 \\ 2697 - 1522 \cos \theta + \omega^2 \cos \theta &= 0 \quad \dots \text{ (Dividing by 0.0575)} \\ \omega^2 \cos \theta &= 1522 \cos \theta - 2697 \quad \text{or} \quad \omega^2 = 1522 - 2697 \sec \theta \end{aligned}$$

Since $\sec \theta \geq +1$ or ≤ -1 , therefore the minimum value of ω^2 occurs when $\theta = 180^\circ$ therefore

$$\omega^2 = 1522 - (-2697) = 4219 \quad \dots \text{ [Substituting } \sec \theta = -1 \text{]}$$

$\therefore \omega = 65 \text{ rad/s}$
and maximum allowable cam shaft speed,

$$N = \frac{\omega \times 60}{2\pi} = \frac{65 \times 60}{2\pi} = 621 \text{ r.p.m. Ans.}$$

EXERCISES

1. A disc cam is to give uniform motion to a knife edge follower during out stroke of 50 mm during the first half of the cam revolution. The follower again returns to its original position with uniform motion during the next half of the revolution. The minimum radius of the cam is 50 mm and the diameter of the cam shaft is 35 mm. Draw the profile of the cam when 1. the axis of follower passes through the axis of cam shaft, and 2. the axis of follower is offset by 20 mm from the axis of the cam shaft.
2. A cam operating a knife-edged follower has the following data :
 - (a) Follower moves outwards through 40 mm during 60° of cam rotation.
 - (b) Follower dwells for the next 45° .
 - (c) Follower returns to its original position during next 90° .
 - (d) Follower dwells for the rest of the rotation.

The displacement of the follower is to take place with simple harmonic motion during both the outward and return strokes. The least radius of the cam is 50 mm. Draw the profile of the cam when 1. the axis of the follower passes through the cam axis, and 2. the axis of the follower is offset 20 mm towards right from the cam axis. If the cam rotates at 300 r.p.m., determine maximum velocity and acceleration of the follower during the outward stroke and the return stroke.

[Ans. 1.88 m/s, 1.26 m/s ; 177.7 m/s², 79 m/s²]
3. A disc cam rotating in a clockwise direction is used to move a reciprocating roller with simple harmonic motion in a radial path, as given below :
 - (i) Outstroke with maximum displacement of 25 mm during 120° of cam rotation,
 - (ii) Dwell for 60° of cam rotation,
 - (iii) Return stroke with maximum displacement of 25 mm during 90° of cam rotation, and
 - (iv) Dwell during remaining 90° of cam rotation.

The line of reciprocation of follower passes through the camshaft axis. The maximum radius of cam is 20 mm. If the cam rotates at a uniform speed of 300 r.p.m. find the maximum velocity and acceleration during outstroke and return stroke. The roller diameter is 8 mm.

828 • Theory of Machines

Draw the profile of the cam when the line of reciprocation of the follower is offset by 20 mm towards right from the cam shaft axis. **[Ans. 0.59 m/s, 0.786 m/s ; 27.8 m/s², 49.4 m/s²]**

4. Design a cam to raise a valve with simple harmonic motion through 50 mm in 1/3 of a revolution, keep it fully raised through 1/12 revolution and to lower it with harmonic motion in 1/6 revolution. The valve remains closed during the rest of the revolution. The diameter of the roller is 20 mm and the minimum radius of the cam is 25 mm. The diameter of the camshaft is 25 mm. The axis of the valve rod passes through the axis of the camshaft. If the camshaft rotates at uniform speed of 100 r.p.m. ; find the maximum velocity and acceleration of a valve during raising and lowering.

[Ans. 0.39 m/s, 0.78 m/s ; 6.17 m/s², 24.67 m/s²]

5. A cam rotating clockwise with a uniform speed is to give the roller follower of 20 mm diameter with the following motion :

- (a) Follower to move outwards through a distance of 30 mm during 120° of cam rotation ;
- (b) Follower to dwell for 60° of cam rotation ;
- (c) Follower to return to its initial position during 90° of cam rotation ; and
- (d) Follower to dwell for the remaining 90° of cam rotation.

The minimum radius of the cam is 45 mm and the line of stroke of the follower is offset 15 mm from the axis of the cam and the displacement of the follower is to take place with simple harmonic motion on both the outward and return strokes. Draw the cam profile.

6. A cam rotating clockwise at a uniform speed of 100 r.p.m. is required to give motion to knife-edge follower as below :

- (a) Follower to move outwards through 25 mm during 120° of cam rotation,
- (b) Follower to dwell for the next 60° of cam rotation,
- (c) Follower to return to its starting position during next 90° of cam rotation, and
- (d) Follower to dwell for the rest of the cam rotation.

The minimum radius of the cam is 50 mm and the line of stroke of the follower passes through the axis of the cam shaft. If the displacement of the follower takes place with uniform and equal acceleration and retardation on both the outward and return strokes, find the maximum velocity and acceleration during outstroke and return stroke. **[Ans. 0.25 m/s, 0.33 m/s ; 2.5 m/s², 4.44 m/s²]**

7. A cam with 30 mm as minimum diameter is rotating clockwise at a uniform speed of 1200 r.p.m. and has to give the following motion to a roller follower 10 mm in diameter:

- (a) Follower to complete outward stroke of 25 mm during 120° of cam rotation with equal uniform acceleration and retardation ;
- (b) Follower to dwell for 60° of cam rotation ;
- (c) Follower to return to its initial position during 90° of cam rotation with equal uniform acceleration and retardation ;
- (d) Follower to dwell for the remaining 90° of cam rotation.

Draw the cam profile if the axis of the roller follower passes through the axis of the cam.

Determine the maximum velocity of the follower during the outstroke and return stroke and also the uniform acceleration of the follower on the out stroke and the return stroke.

[Ans. 3 m/s, 4 m/s ; 360.2 m/s², 640.34 m/s²]

8. A cam rotating clockwise at a uniform speed of 200 r.p.m. is required to move an offset roller follower with a uniform and equal acceleration and retardation on both the outward and return strokes. The angle of ascent, the angle of dwell (between ascent and descent) and the angle of descent is 120°, 60° and 90° respectively. The follower dwells for the rest of cam rotation. The least radius of the cam is 50 mm, the lift of the follower is 25 mm and the diameter of the roller is 10 mm. The line of stroke of the follower is offset by 20 mm from the axis of the cam. Draw the cam profile and find the maximum velocity and acceleration of the follower during the outstroke.

9. A flat faced reciprocating follower has the following motion :

- (i) The follower moves out for 80° of cam rotation with uniform acceleration and retardation, the acceleration being twice the retardation.
- (ii) The follower dwells for the next 80° of cam rotation.
- (iii) It moves in for the next 120° of cam rotation with uniform acceleration and retardation, the retardation being twice the acceleration.
- (iv) The follower dwells for the remaining period.

The base circle diameter of the cam is 60 mm and the stroke of the follower is 20 mm. The line of movement of the follower passes through the cam centre.

Draw the displacement diagram and the profile of the cam very neatly showing all constructional details.

10. From the following data, draw the profile of a cam in which the follower moves with simple harmonic motion during ascent while it moves with uniformly accelerated motion during descent :

Least radius of cam = 50 mm ; Angle of ascent = 48° ; Angle of dwell between ascent and descent = 42° ; Angle of descent = 60° ; Lift of follower = 40 mm ; Diameter of roller = 30 mm ; Distance between the line of action of follower and the axis of cam = 20 mm.

If the cam rotates at 360 r.p.m. anticlockwise, find the maximum velocity and acceleration of the follower during descent. [Ans. 2.88 m/s ; 207.4 m/s²]

11. Draw the profile of a cam with oscillating roller follower for the following motion :

- (a) Follower to move outwards through an angular displacement of 20° during 120° of cam rotation.
- (b) Follower to dwell for 50° of cam rotation.
- (c) Follower to return to its initial position in 90° of cam rotation with uniform acceleration and retardation.
- (d) Follower to dwell for the remaining period of cam rotation.

The distance between the pivot centre and the roller centre is 130 mm and the distance between the pivot centre and cam axis is 150 mm. The minimum radius of the cam is 80 mm and the diameter of the roller is 50 mm.

12. Draw the profile of the cam when the roller follower moves with cycloidal motion as given below :

- (a) Outstroke with maximum displacement of 44 mm during 180° of cam rotation.
- (b) Return stroke for the next 150° of cam rotation.
- (c) Dwell for the remaining 30° of cam rotation.

The minimum radius of the cam is 20 mm and the diameter of the roller is 10 mm. The axis of the roller follower passes through the cam shaft axis.

13. A symmetrical tangent cam operating a roller follower has the following particulars :

Radius of base circle of cam = 40 mm, roller radius = 20 mm, angle of ascent = 75° , total lift = 20 mm, speed of cam shaft = 300 r.p.m.

Determine : 1. the principal dimensions of the cam, 2. the equation for the displacement curve, when the follower is in contact with the straight flank, and 3. the acceleration of the follower when it is in contact with the straight flank where it merges into the circular nose.

[Ans. $r_3 = 33$ mm ; $\theta = 23.5^\circ$; 89.4 m/s²]

14. A cam profile consists of two circular arcs of radii 24 mm and 12 mm, joined by straight lines, giving the follower a lift of 12 mm. The follower is a roller of 24 mm radius and its line of action is a straight line passing through the cam shaft axis. When the cam shaft has a uniform speed of 500 rev/min, find the maximum velocity and acceleration of the follower while in contact with the straight flank of the cam. [Ans. 1.2 m/s ; 198 m/s²]

15. The following particulars relate to a symmetrical tangent cam operating a roller follower :-

Least radius = 30 mm, nose radius = 24 mm, roller radius = 17.5 mm, distance between cam shaft and nose centre = 23.5 mm, angle of action of cam = 150° , cam shaft speed = 600 r.p.m.

Assuming that there is no dwell between ascent and descent, determine the lift of the valve and the

830 • Theory of Machines

acceleration of the follower at a point where straight flank merges into the circular nose.

[Ans. 17.5 mm ; 304.5 m/s²]

16. Following is the data for a circular arc cam working with a flat faced reciprocating follower :
Minimum radius of the cam = 30 mm ; Total angle of cam action = 120° ; Radius of the circular arc = 80 mm ; Nose radius = 10 mm.

1. Find the distance of the centre of nose circle from the cam axis ; 2. Draw the profile of the cam to full scale ; 3. Find the angle through which the cam turns when the point of contact moves from the junction of minimum radius arc and circular arc to the junction of nose radius arc and circular arc ; and 4. Find the velocity and acceleration of the follower when the cam has turned through an angle of $\theta = 20^\circ$. The angle θ is measured from the point where the follower just starts moving away from the cam. The angular velocity of the cam is 10 rad/s.

[Ans. 30 mm ; 22° ; 68.4 mm/s ; 1880 mm/s²]

17. The suction valve of a four stroke petrol engine is operated by a circular arc cam with a flat faced follower. The lift of the follower is 10 mm ; base circle diameter of the cam is 40 mm and the nose radius is 2.5 mm. The crank angle when suction valve opens is 4° after top dead centre and when the suction valve closes, the crank angle is 50° after bottom dead centre. If the cam shaft rotates at 600 r.p.m., determine: 1. maximum velocity of the valve, and 2. maximum acceleration and retardation of the valve.

[Ans. 1.22 m/s ; 383 m/s², 108.6 m/s²]

[Hint. Total angle turned by the crankshaft when valve is open

$$= 180^\circ - 4^\circ + 50^\circ = 226^\circ$$

Since the engine is a four stroke cycle, therefore speed of cam shaft is half of the speed of the crank shaft.

∴ Total angle turned by the cam shaft during opening of valve, $2\alpha = 226/2 = 113^\circ$ or $\alpha = 56.5^\circ$].

18. The following particulars relate to a symmetrical circular cam operating a flat-faced follower :
Least radius = 25 mm ; nose radius = 8 mm, lift of the valve = 10 mm, angle of action of cam = 120°, cam shaft speed = 1000 r.p.m.

Determine the flank radius and the maximum velocity, acceleration and retardation of the follower. If the mass of the follower and valve with which it is in contact is 4 kg, find the minimum force to be exerted by the spring to overcome inertia of the valve parts.

[Ans. 88 mm ; 1.93 m/s, 690.6 m/s², 296 m/s² ; 1184 N]

DO YOU KNOW ?

1. Write short notes on cams and followers.
2. Explain with sketches the different types of cams and followers.
3. Why a roller follower is preferred to that of a knife-edged follower ?
4. Define the following terms as applied to cam with a neat sketch :-
(a) Base circle, (b) Pitch circle, (c) Pressure angle, and (d) Stroke of the follower.
5. What are the different types of motion with which a follower can move ?
6. Draw the displacement, velocity and acceleration diagrams for a follower when it moves with simple harmonic motion. Derive the expression for velocity and acceleration during outstroke and return stroke of the follower.
7. Draw the displacement, velocity and acceleration diagrams for a follower when it moves with uniform acceleration and retardation. Derive the expression for velocity and acceleration during outstroke and return stroke of the follower.
8. Derive expressions for displacement, velocity and acceleration for a tangent cam operating on a radial-translating roller follower :

- (i) when the contact is on straight flank, and
(ii) when the contact is on circular nose.
9. Derive the expressions for displacement, velocity and acceleration for a circular arc cam operating a flat-faced follower
(i) when the contact is on the circular flank, and
(ii) when the contact is on circular nose.

OBJECTIVE TYPE QUESTIONS

- The size of a cam depends upon
(a) base circle (b) pitch circle (c) prime circle (d) pitch curve
- The angle between the direction of the follower motion and a normal to the pitch curve is called
(a) pitch angle (b) prime angle
(c) base angle (d) pressure angle
- A circle drawn with centre as the cam centre and radius equal to the distance between the cam centre and the point on the pitch curve at which the pressure angle is maximum, is called
(a) base circle (b) pitch circle
(c) prime circle (d) none of these
- The cam follower generally used in automobile engines is
(a) knife edge follower (b) flat faced follower
(c) spherical faced follower (d) roller follower
- The cam follower extensively used in air-craft engines is
(a) knife edge follower (b) flat faced follower
(c) spherical faced follower (d) roller follower
- In a radial cam, the follower moves
(a) in a direction perpendicular to the cam axis
(b) in a direction parallel to the cam axis
(c) in any direction irrespective of the cam axis
(d) along the cam axis
- A radial follower is one
(a) that reciprocates in the guides (b) that oscillates
(c) in which the follower translates along an axis passing through the cam centre of rotation.
(d) none of the above
- Offset is provided to a cam follower mechanism to
(a) minimise the side thrust (b) accelerate
(c) avoid jerk (d) none of these
- For low and moderate speed engines, the cam follower should move with
(a) uniform velocity (b) simple harmonic motion
(c) uniform acceleration and retardation (d) cycloidal motion
- For high speed engines, the cam follower should move with
(a) uniform velocity (b) simple harmonic motion
(c) uniform acceleration and retardation (d) cycloidal motion
- Which of the following displacement diagrams should be chosen for better dynamic performance of a cam-follower mechanism ?
(a) simple harmonic motion (b) parabolic motion
(c) cycloidal motion (d) none of these

832 • Theory of Machines

- 12.** For a given lift of the follower of a cam follower mechanism, a smaller base circle diameter is desired.
- (a) because it will give a steeper cam and higher pressure angle.
 (b) because it will give a profile with lower pressure angle
 (c) because it will avoid jumping
 (d) none of the above.

- 13.** The linear velocity of the reciprocating roller follower when it has contact with the straight flanks of the tangent cam, is given by

(a) $\omega(r_1 - r_2)\sin\theta$ (b) $\omega(r_1 - r_2)\cos\theta$
 (c) $\omega(r_1 + r_2)\sin\theta\sec^2\theta$ (d) $\omega(r_1 + r_2)\cos\theta\operatorname{cosec}^2\theta$

where ω = Angular velocity of the cam shaft,
 r_1 = Minimum radius of the cam,
 r_2 = Radius of the roller, and
 θ = Angle turned by the cam from the beginning of the displacement for contact of roller with the straight flanks.

- 14.** The displacement of a flat faced follower when it has contact with the flank of a circular arc cam, is given by

(a) $R(1 - \cos\theta)$ (b) $R(1 - \sin\theta)$
 (c) $(R - r_1)(1 - \cos\theta)$ (d) $(R - r_1)(1 - \sin\theta)$

where R = Radius of the flank,
 r_1 = Minimum radius of the cam, and
 θ = Angle turned by the cam for contact with the circular flank.

- 15.** The retardation of a flat faced follower when it has contact at the apex of the nose of a circular arc cam, is given by

(a) $\omega^2 \times OQ$ (b) $\omega^2 \times OQ \sin\theta$
 (c) $\omega^2 \times OQ \cos\theta$ (d) $\omega^2 \times OQ \tan\theta$

where OQ = Distance between the centre of circular flank and centre of nose.

ANSWERS

- | | | | | |
|----------------|----------------|----------------|----------------|----------------|
| 1. (a) | 2. (d) | 3. (b) | 4. (c) | 5. (d) |
| 6. (a) | 7. (a) | 8. (a) | 9. (b) | 10. (d) |
| 11. (c) | 12. (d) | 13. (c) | 14. (c) | 15. (a) |