



# 18

## Governors

### Features

1. Introduction.
2. Types of Governors.
3. Centrifugal Governors.
4. Terms Used in Governors.
5. Watt Governor.
6. Porter Governor.
7. Proell Governor.
8. Hartnell Governor.
9. Hartung Governor.
10. Wilson-Hartnell Governor.
11. Pickering Governor.
12. Sensitiveness of Governors.
13. Stability of Governors.
14. Isochronous Governor.
15. Hunting.
16. Effort and Power of a Governor.
17. Effort and Power of a Porter Governor.
18. Controlling Force.
19. Controlling Force Diagram for a Porter Governor.
20. Controlling Force Diagram for a Spring-controlled Governor.
21. Coefficient of Insensitiveness.

### 18.1. Introduction

The function of a governor is to regulate the mean speed of an engine, when there are variations in the load *e.g.* when the load on an engine increases, its speed decreases, therefore it becomes necessary to increase the supply of working fluid. On the other hand, when the load on the engine decreases, its speed increases and thus less working fluid is required. The governor automatically controls the supply of working fluid to the engine with the varying load conditions and keeps the mean speed within certain limits.

A little consideration will show, that when the load increases, the configuration of the governor changes and a valve is moved to increase the supply of the working fluid ; **conversely**, when the load decreases, the engine speed increases and the governor decreases the supply of working fluid.

**Note :** We have discussed in Chapter 16 (Art. 16.8) that the function of a flywheel in an engine is entirely different from that of a governor. It controls the speed variation caused by the fluctuations of the engine turning moment during each cycle of operation. It does not control the speed variations caused by a varying load. The varying demand for power is met by the governor regulating the supply of working fluid.

### 18.2. Types of Governors

The governors may, broadly, be classified as

1. Centrifugal governors, and 2. Inertia governors.

## 654 • Theory of Machines

The centrifugal governors, may further be classified as follows :

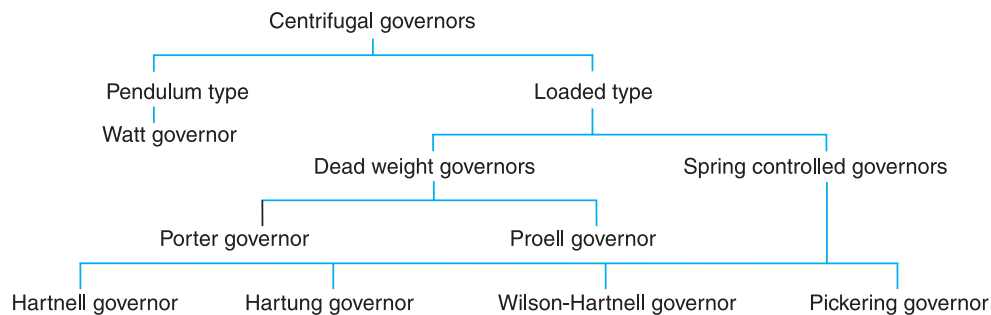

### 18.3. Centrifugal Governors

The centrifugal governors are based on the balancing of centrifugal force on the rotating balls by an equal and opposite radial force, known as the *controlling force*\*. It consists of two balls of equal mass, which are attached to the arms as shown in Fig. 18.1. These balls are known as *governor balls or fly balls*. The balls revolve with a spindle, which is driven by the engine through bevel gears. The upper ends of the arms are pivoted to the spindle, so that the balls may rise up or fall down as they revolve about the vertical axis. The arms are connected by the links to a sleeve, which is keyed to the spindle. This sleeve revolves with the spindle ; but can slide up and down. The balls and the sleeve rises when the spindle speed increases, and falls when the speed decreases. In order to limit the travel of the sleeve in upward and downward directions, two stops *S, S* are provided on the spindle. The sleeve is connected by a bell crank lever to a throttle valve. The supply of the working fluid decreases when the sleeve rises and increases when it falls.

When the load on the engine increases, the engine and the governor speed decreases. This results in the decrease of centrifugal force on the balls. Hence the balls move inwards and the sleeve moves downwards. The downward movement of the sleeve operates a throttle valve at the other end of the bell crank lever to increase the supply of working fluid and thus the engine speed is increased. In this case, the extra power output is provided to balance the increased load. When the load on the engine decreases, the engine and the governor speed increases, which results in the increase of centrifugal force on the balls. Thus the balls move outwards and the sleeve rises upwards. This upward movement of the sleeve reduces the supply of the working fluid and hence the speed is decreased. In this case, the power output is reduced.

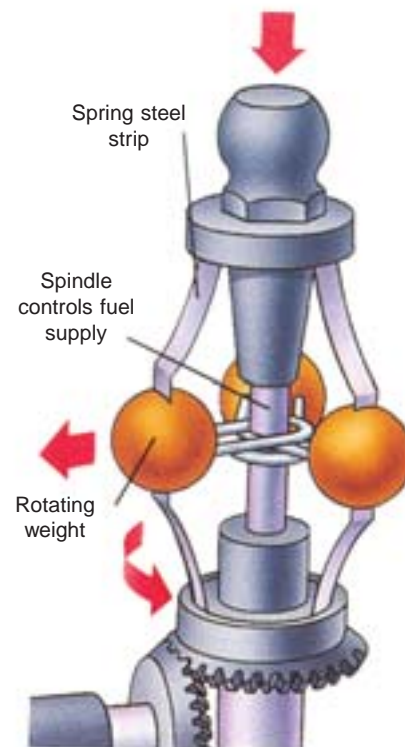

A governor controls engine speed. As it rotates, the weights swing outwards, pulling down a spindle that reduces the fuel supply at high speed.

\* The controlling force is provided either by the action of gravity as in Watt governor or by a spring as in case of Hartnell governor.

**Note :** When the balls rotate at uniform speed, controlling force is equal to the centrifugal force and they balance each other.

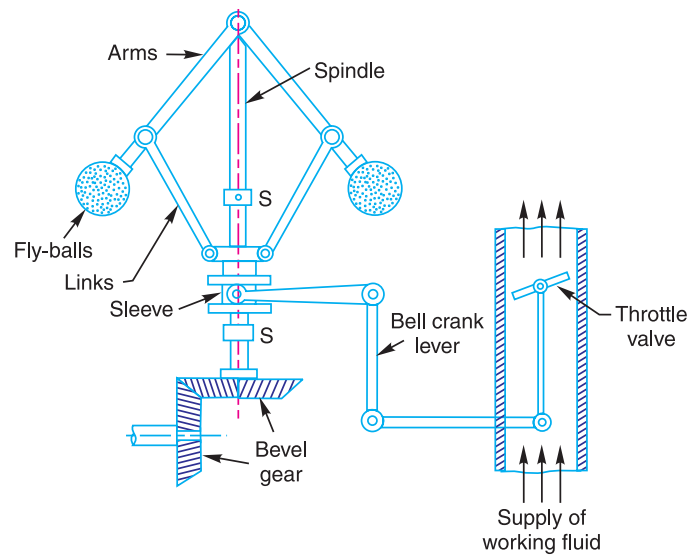

**Fig. 18.1.** Centrifugal governor.

#### 18.4. Terms Used in Governors

The following terms used in governors are important from the subject point of view ;

**1. Height of a governor.** It is the vertical distance from the centre of the ball to a point where the axes of the arms (or arms produced) intersect on the spindle axis. It is usually denoted by  $h$ .

**2. Equilibrium speed.** It is the speed at which the governor balls, arms etc., are in complete equilibrium and the sleeve does not tend to move upwards or downwards.

**3. Mean equilibrium speed.** It is the speed at the mean position of the balls or the sleeve.

**4. Maximum and minimum equilibrium speeds.** The speeds at the maximum and minimum radius of rotation of the balls, without tending to move either way are known as maximum and minimum equilibrium speeds respectively.

**Note :** There can be many equilibrium speeds between the mean and the maximum and the mean and the minimum equilibrium speeds.

**5. Sleeve lift.** It is the vertical distance which the sleeve travels due to change in equilibrium speed.



Centrifugal governor

### 18.5. Watt Governor

The simplest form of a centrifugal governor is a Watt governor, as shown in Fig. 18.2. It is basically a conical pendulum with links attached to a sleeve of negligible mass. The arms of the governor may be connected to the spindle in the following three ways :

1. The pivot  $P$ , may be on the spindle axis as shown in Fig. 18.2 (a).
2. The pivot  $P$ , may be offset from the spindle axis and the arms when produced intersect at  $O$ , as shown in Fig. 18.2 (b).
3. The pivot  $P$ , may be offset, but the arms cross the axis at  $O$ , as shown in Fig. 18.2 (c).

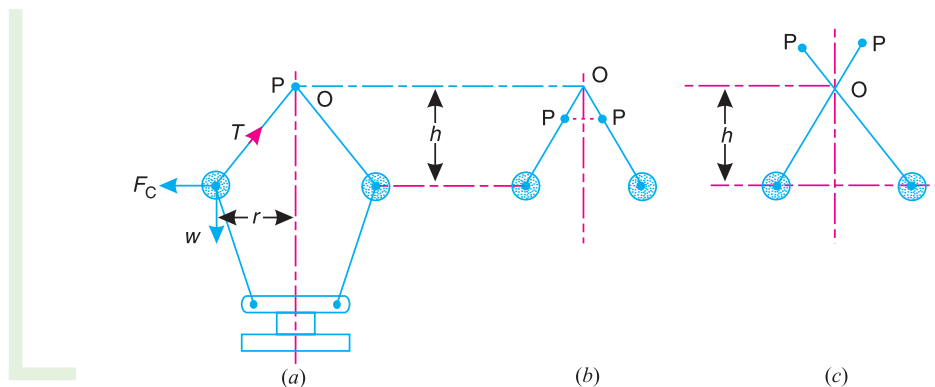

Fig. 18.2. Watt governor.

Let

- $m$  = Mass of the ball in kg,
- $w$  = Weight of the ball in newtons =  $m.g$ ,
- $T$  = Tension in the arm in newtons,
- $\omega$  = Angular velocity of the arm and ball about the spindle axis in rad/s,
- $r$  = Radius of the path of rotation of the ball *i.e.* horizontal distance from the centre of the ball to the spindle axis in metres,
- $F_C$  = Centrifugal force acting on the ball in newtons =  $m. \omega^2.r$ , and
- $h$  = Height of the governor in metres.

It is assumed that the weight of the arms, links and the sleeve are negligible as compared to the weight of the balls. Now, the ball is in equilibrium under the action of

1. the centrifugal force ( $F_C$ ) acting on the ball,
2. the tension ( $T$ ) in the arm,
3. the weight ( $w$ ) of the ball.

Taking moments about point  $O$ , we have

$$F_C \times h = w \times r = m.g.r$$

or  $m. \omega^2.r.h = m.g.r$  or  $h = g / \omega^2$  ... (i)

When  $g$  is expressed in  $m/s^2$  and  $\omega$  in rad/s, then  $h$  is in metres. If  $N$  is the speed in r.p.m., then

$$\omega = 2 \pi N/60$$

$\therefore h = \frac{9.81}{(2\pi N/60)^2} = \frac{895}{N^2}$  metres ... ( $\because g = 9.81 \text{ m/s}^2$ ) ... (ii)

**Note :** We see from the above expression that the height of a governor  $h$ , is inversely proportional to  $N^2$ . Therefore at high speeds, the value of  $h$  is small. At such speeds, the change in the value of  $h$  corresponding to a small change in speed is insufficient to enable a governor of this type to operate the mechanism to give the necessary change in the fuel supply. This governor may only work satisfactorily at relatively low speeds *i.e.* from 60 to 80 r.p.m.

**Example 18.1.** Calculate the vertical height of a Watt governor when it rotates at 60 r.p.m. Also find the change in vertical height when its speed increases to 61 r.p.m.

**Solution.** Given :  $N_1 = 60$  r.p.m. ;  $N_2 = 61$  r.p.m.

**Initial height**

We know that initial height,

$$h_1 = \frac{895}{(N_1)^2} = \frac{895}{(60)^2} = 0.248 \text{ m}$$

**Change in vertical height**

We know that final height,

$$h_2 = \frac{895}{(N_2)^2} = \frac{895}{(61)^2} = 0.24 \text{ m}$$

∴ Change in vertical height

$$= h_1 - h_2 = 0.248 - 0.24 = 0.008 \text{ m} = 8 \text{ mm Ans.}$$

**18.6. Porter Governor**

The Porter governor is a modification of a Watt’s governor, with central load attached to the sleeve as shown in Fig. 18.3 (a). The load moves up and down the central spindle. This additional downward force increases the speed of revolution required to enable the balls to rise to any pre-determined level.

Consider the forces acting on one-half of the governor as shown in Fig. 18.3 (b).

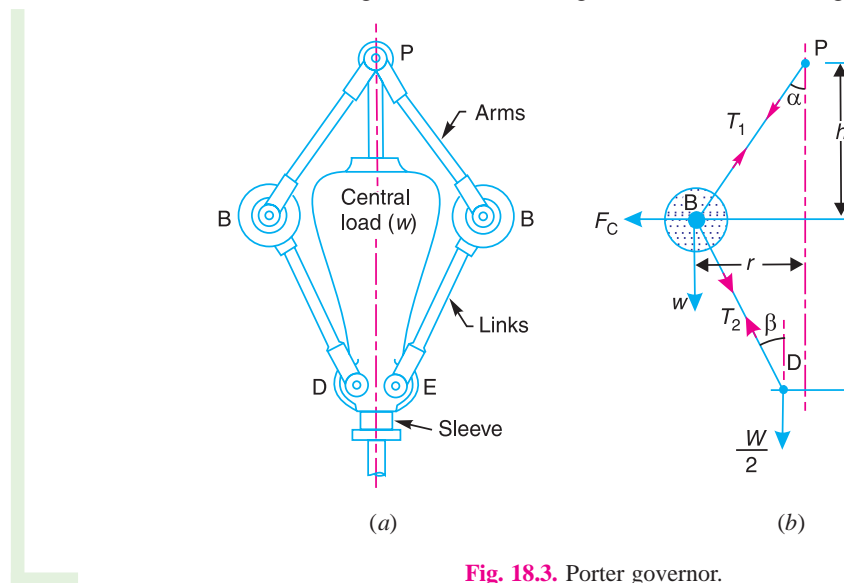

**Fig. 18.3.** Porter governor.

Let

$m$  = Mass of each ball in kg,

$w$  = Weight of each ball in newtons =  $m.g$ ,

$M$  = Mass of the central load in kg,

$W$  = Weight of the central load in newtons =  $M.g$ ,

$r$  = Radius of rotation in metres,

658 • Theory of Machines

- $h$  = Height of governor in metres ,
- $N$  = Speed of the balls in r.p.m .,
- $\omega$  = Angular speed of the balls in rad/s  
 $= 2\pi N/60$  rad/s,
- $F_C$  = Centrifugal force acting on the ball  
in newtons  $= m \cdot \omega^2 \cdot r$ ,
- $T_1$  = Force in the arm in newtons,
- $T_2$  = Force in the link in newtons,
- $\alpha$  = Angle of inclination of the arm (or  
upper link) to the vertical, and
- $\beta$  = Angle of inclination of the link  
(or lower link) to the vertical.

Though there are several ways of determining the relation between the height of the governor ( $h$ ) and the angular speed of the balls ( $\omega$ ), yet the following two methods are important from the subject point of view :

1. Method of resolution of forces ; and
2. Instantaneous centre method.

**1. Method of resolution of forces**

Considering the equilibrium of the forces acting at  $D$ , we have

$$T_2 \cos \beta = \frac{W}{2} = \frac{M \cdot g}{2}$$

or 
$$T_2 = \frac{M \cdot g}{2 \cos \beta} \quad \dots (i)$$

Again, considering the equilibrium of the forces acting on  $B$ . The point  $B$  is in equilibrium under the action of the following forces, as shown in Fig. 18.3 (b).

- (i) The weight of ball ( $w = m \cdot g$ ),
- (ii) The centrifugal force ( $F_C$ ),
- (iii) The tension in the arm ( $T_1$ ), and
- (iv) The tension in the link ( $T_2$ ).

Resolving the forces vertically,

$$T_1 \cos \alpha = T_2 \cos \beta + w = \frac{M \cdot g}{2} + m \cdot g \quad \dots (ii)$$

$$\dots \left( \because T_2 \cos \beta = \frac{M \cdot g}{2} \right)$$

Resolving the forces horizontally,

$$T_1 \sin \alpha + T_2 \sin \beta = F_C$$

$$T_1 \sin \alpha + \frac{M \cdot g}{2 \cos \beta} \times \sin \beta = F_C \quad \dots \left( \because T_2 = \frac{M \cdot g}{2 \cos \beta} \right)$$

$$T_1 \sin \alpha + \frac{M \cdot g}{2} \times \tan \beta = F_C$$

$$\therefore T_1 \sin \alpha = F_C - \frac{M \cdot g}{2} \times \tan \beta \quad \dots (iii)$$



A big hydrel generator. Governors are used to control the supply of working fluid (water in hydrel generators).

Note : This picture is given as additional information and is not a direct example of the current chapter.

Dividing equation (iii) by equation (ii),

$$\frac{T_1 \sin \alpha}{T_1 \cos \alpha} = \frac{F_C - \frac{M \cdot g}{2} \times \tan \beta}{\frac{M \cdot g}{2} + m \cdot g}$$

or  $\left(\frac{M \cdot g}{2} + m \cdot g\right) \tan \alpha = F_C - \frac{M \cdot g}{2} \times \tan \beta$

$$\frac{M \cdot g}{2} + m \cdot g = \frac{F_C}{\tan \alpha} - \frac{M \cdot g}{2} \times \frac{\tan \beta}{\tan \alpha}$$

Substituting  $\frac{\tan \beta}{\tan \alpha} = q$ , and  $\tan \alpha = \frac{r}{h}$ , we have

$$\frac{M \cdot g}{2} + m \cdot g = m \cdot \omega^2 \cdot r \times \frac{h}{r} - \frac{M \cdot g}{2} \times q \quad \dots (\because F_C = m \cdot \omega^2 \cdot r)$$

or  $m \cdot \omega^2 \cdot h = m \cdot g + \frac{M \cdot g}{2} (1 + q)$

$$\therefore h = \left[ m \cdot g + \frac{M \cdot g}{2} (1 + q) \right] \frac{1}{m \cdot \omega^2} = \frac{m + \frac{M}{2} (1 + q)}{m} \times \frac{g}{\omega^2} \quad \dots (iv)$$

or  $\omega^2 = \left[ m \cdot g + \frac{M \cdot g}{2} (1 + q) \right] \frac{1}{m \cdot h} = \frac{m + \frac{M}{2} (1 + q)}{m} \times \frac{g}{h}$

or  $\left(\frac{2\pi N}{60}\right)^2 = \frac{m + \frac{M}{2} (1 + q)}{m} \times \frac{g}{h}$

$$\therefore N^2 = \frac{m + \frac{M}{2} (1 + q)}{m} \times \frac{g}{h} \left(\frac{60}{2\pi}\right)^2 = \frac{m + \frac{M}{2} (1 + q)}{m} \times \frac{895}{h} \quad \dots (v)$$

... (Taking  $g = 9.81 \text{ m/s}^2$ )

**Notes : 1.** When the length of arms are equal to the length of links and the points  $P$  and  $D$  lie on the same vertical line, then

$$\tan \alpha = \tan \beta \quad \text{or} \quad q = \tan \alpha / \tan \beta = 1$$

Therefore, the equation (v) becomes

$$N^2 = \frac{(m + M)}{m} \times \frac{895}{h} \quad \dots (vi)$$

**2.** When the loaded sleeve moves up and down the spindle, the frictional force acts on it in a direction opposite to that of the motion of sleeve.

If  $F$  = Frictional force acting on the sleeve in newtons, then the equations (v) and (vi) may be written as

$$N^2 = \frac{m \cdot g + \left(\frac{M \cdot g \pm F}{2}\right) (1 + q)}{m \cdot g} \times \frac{895}{h} \quad \dots (vii)$$

$$= \frac{m \cdot g + (M \cdot g \pm F)}{m \cdot g} \times \frac{895}{h} \quad \dots (\text{When } q = 1) \dots (viii)$$

## 660 • Theory of Machines

The + sign is used when the sleeve moves upwards or the governor speed increases and negative sign is used when the sleeve moves downwards or the governor speed decreases.

3. On comparing the equation (vi) with equation (ii) of Watt's governor (Art. 18.5), we find that the mass of the central load ( $M$ ) increases the height of governor in the ratio  $\frac{m+M}{m}$ .

### 2. Instantaneous centre method

In this method, equilibrium of the forces acting on the link  $BD$  are considered. The instantaneous centre  $I$  lies at the point of intersection of  $PB$  produced and a line through  $D$  perpendicular to the spindle axis, as shown in Fig. 18.4. Taking moments about the point  $I$ ,

$$F_C \times BM = w \times IM + \frac{W}{2} \times ID$$

$$= m \cdot g \times IM + \frac{M \cdot g}{2} \times ID$$

$$\therefore F_C = m \cdot g \times \frac{IM}{BM} + \frac{M \cdot g}{2} \times \frac{ID}{BM}$$

$$= m \cdot g \times \frac{IM}{BM} + \frac{M \cdot g}{2} \left( \frac{IM + MD}{BM} \right)$$

$$= m \cdot g \times \frac{IM}{BM} + \frac{M \cdot g}{2} \left( \frac{IM}{BM} + \frac{MD}{BM} \right)$$

$$= m \cdot g \tan \alpha + \frac{M \cdot g}{2} (\tan \alpha + \tan \beta)$$

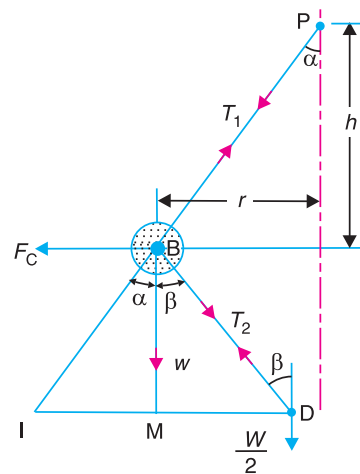

Fig. 18.4. Instantaneous centre method.

$$\dots \left( \because \frac{IM}{BM} = \tan \alpha, \text{ and } \frac{MD}{BM} = \tan \beta \right)$$

Dividing throughout by  $\tan \alpha$ ,

$$\frac{F_C}{\tan \alpha} = m \cdot g + \frac{M \cdot g}{2} \left( 1 + \frac{\tan \beta}{\tan \alpha} \right) = m \cdot g + \frac{M \cdot g}{2} (1 + q) \quad \dots \left( \because q = \frac{\tan \beta}{\tan \alpha} \right)$$

We know that  $F_C = m \cdot \omega^2 \cdot r$ ; and  $\tan \alpha = \frac{r}{h}$

$$\therefore m \cdot \omega^2 \cdot r \times \frac{h}{r} = m \cdot g + \frac{M \cdot g}{2} (1 + q)$$

or 
$$h = \frac{m \cdot g + \frac{M \cdot g}{2} (1 + q)}{m} \times \frac{1}{\omega^2} = \frac{m + \frac{M}{2} (1 + q)}{m} \times \frac{g}{\omega^2}$$

... (Same as before)

When  $\tan \alpha = \tan \beta$  or  $q = 1$ , then

$$h = \frac{m + M}{m} \times \frac{g}{\omega^2}$$



**Example 18.2.** A Porter governor has equal arms each 250 mm long and pivoted on the axis of rotation. Each ball has a mass of 5 kg and the mass of the central load on the sleeve is 25 kg. The radius of rotation of the ball is 150 mm when the governor begins to lift and 200 mm when the governor is at maximum speed. Find the minimum and maximum speeds and range of speed of the governor.

**Solution.** Given :  $BP = BD = 250 \text{ mm} = 0.25 \text{ m}$  ;  $m = 5 \text{ kg}$  ;  $M = 15 \text{ kg}$  ;  $r_1 = 150 \text{ mm} = 0.15 \text{ m}$  ;  $r_2 = 200 \text{ mm} = 0.2 \text{ m}$

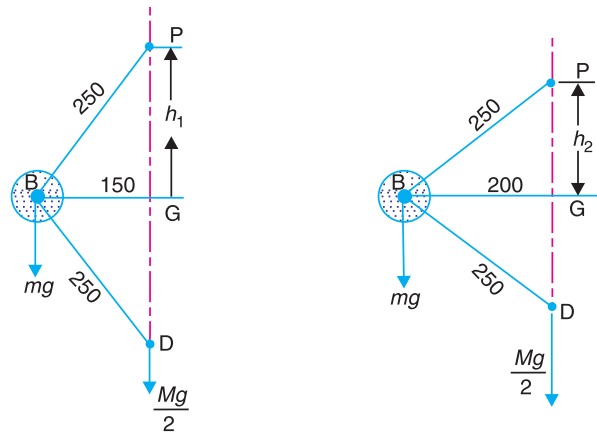

(a) Minimum position.

(b) Maximum position.

**Fig. 18.5**

The minimum and maximum positions of the governor are shown in Fig. 18.5 (a) and (b) respectively.

**Minimum speed when  $r_1 = BG = 0.15 \text{ m}$**

Let  $N_1 =$  Minimum speed.

From Fig. 18.5 (a), we find that height of the governor,

$$h_1 = PG = \sqrt{(PB)^2 - (BG)^2} = \sqrt{(0.25)^2 - (0.15)^2} = 0.2 \text{ m}$$

We know that

$$(N_1)^2 = \frac{m + M}{m} \times \frac{895}{h_1} = \frac{5 + 15}{5} \times \frac{895}{0.2} = 17\,900$$

$\therefore N_1 = 133.8 \text{ r.p.m. Ans.}$

**Maximum speed when  $r_2 = BG = 0.2 \text{ m}$**

Let  $N_2 =$  Maximum speed.

From Fig. 18.5 (b), we find that height of the governor,

$$h_2 = PG = \sqrt{(PB)^2 - (BG)^2} = \sqrt{(0.25)^2 - (0.2)^2} = 0.15 \text{ m}$$

We know that

$$(N_2)^2 = \frac{m + M}{m} \times \frac{895}{h_2} = \frac{5 + 15}{5} \times \frac{895}{0.15} = 23\,867$$

$\therefore N_2 = 154.5 \text{ r.p.m. Ans.}$

**Range of speed**

We know that range of speed

$$= N_2 - N_1 = 154.4 - 133.8 = 20.7 \text{ r.p.m. Ans.}$$

**Example 18.3.** The arms of a Porter governor are each 250 mm long and pivoted on the governor axis. The mass of each ball is 5 kg and the mass of the central sleeve is 30 kg. The radius of rotation of the balls is 150 mm when the sleeve begins to rise and reaches a value of 200 mm for maximum speed. Determine the speed range of the governor. If the friction at the sleeve is equivalent of 20 N of load at the sleeve, determine how the speed range is modified.

**Solution.** Given :  $BP = BD = 250 \text{ mm}$  ;  $m = 5 \text{ kg}$  ;  $M = 30 \text{ kg}$  ;  $r_1 = 150 \text{ mm}$  ;  $r_2 = 200 \text{ mm}$

First of all, let us find the minimum and maximum speed of the governor. The minimum and maximum position of the governor is shown in Fig. 18.6 (a) and (b) respectively.

Let  $N_1$  = Minimum speed when  $r_1 = BG = 150 \text{ mm}$ , and  
 $N_2$  = Maximum speed when  $r_2 = BG = 200 \text{ mm}$ .

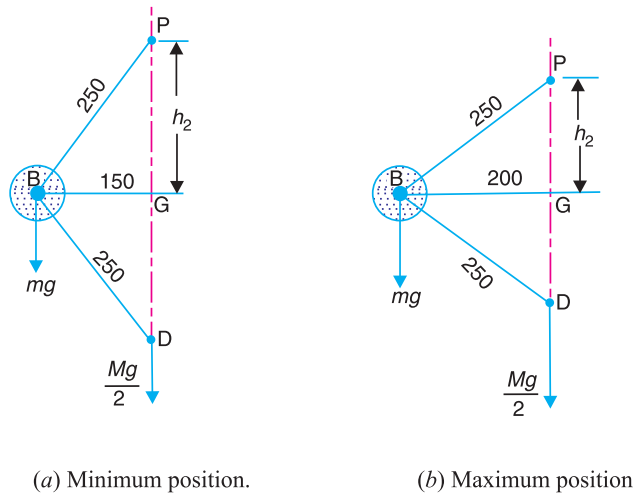

Fig. 18.6

**Speed range of the governor**

From Fig. 18.6 (a), we find that height of the governor,

$$h_1 = PG = \sqrt{(PB)^2 - (BG)^2} = \sqrt{(250)^2 - (150)^2} = 200 \text{ mm} = 0.2 \text{ m}$$

We know that

$$(N_1)^2 = \frac{m + M}{m} \times \frac{895}{h_1} = \frac{5 + 30}{5} \times \frac{895}{0.2} = 31\,325$$

$\therefore N_1 = 177 \text{ r.p.m.}$

From Fig. 18.6 (b), we find that height of the governor,

$$h_2 = PG = \sqrt{(PB)^2 - (BG)^2} = \sqrt{(250)^2 - (200)^2} = 150 \text{ mm} = 0.15 \text{ m}$$

We know that

$$(N_2)^2 = \frac{m + M}{m} \times \frac{895}{h_2} = \frac{5 + 30}{5} \times \frac{895}{0.15} = 41\,767$$

$\therefore N_2 = 204.4 \text{ r.p.m.}$

We know that speed range of the governor

$$= N_2 - N_1 = 204.4 - 177 = 27.4 \text{ r.p.m. Ans.}$$

**Speed range when friction at the sleeve is equivalent of 20 N of load (i.e. when  $F = 20 \text{ N}$ )**

We know that when the sleeve moves downwards, the friction force ( $F$ ) acts upwards and the minimum speed is given by

$$\begin{aligned} (N_1)^2 &= \frac{m \cdot g + (M \cdot g - F)}{m \cdot g} \times \frac{895}{h_1} \\ &= \frac{5 \times 9.81 + (30 \times 9.81 - 20)}{5 \times 9.81} \times \frac{895}{0.2} = 29500 \end{aligned}$$

$$\therefore N_1 = 172 \text{ r.p.m.}$$

We also know that when the sleeve moves upwards, the frictional force ( $F$ ) acts downwards and the maximum speed is given by

$$\begin{aligned} (N_2)^2 &= \frac{m \cdot g + (M \cdot g + F)}{m \cdot g} \times \frac{895}{h_2} \\ &= \frac{5 \times 9.81 + (30 \times 9.81 + 20)}{5 \times 9.81} \times \frac{895}{0.15} = 44200 \end{aligned}$$

$$\therefore N_2 = 210 \text{ r.p.m.}$$

We know that speed range of the governor

$$= N_2 - N_1 = 210 - 172 = 38 \text{ r.p.m. Ans.}$$

**Example 18.4.** In an engine governor of the Porter type, the upper and lower arms are 200 mm and 250 mm respectively and pivoted on the axis of rotation. The mass of the central load is 15 kg, the mass of each ball is 2 kg and friction of the sleeve together with the resistance of the operating gear is equal to a load of 25 N at the sleeve. If the limiting inclinations of the upper arms to the vertical are  $30^\circ$  and  $40^\circ$ , find, taking friction into account, range of speed of the governor.

**Solution .** Given :  $BP = 200 \text{ mm} = 0.2 \text{ m}$  ;  $BD = 250 \text{ mm} = 0.25 \text{ m}$  ;  $M = 15 \text{ kg}$  ;  $m = 2 \text{ kg}$  ;  $F = 25 \text{ N}$  ;  $\alpha_1 = 30^\circ$  ;  $\alpha_2 = 40^\circ$

First of all, let us find the minimum and maximum speed of the governor.

The minimum and maximum position of the governor is shown Fig. 18.7 (a) and (b) respectively.

Let  $N_1 =$  Minimum speed, and

$N_2 =$  Maximum speed.

From Fig. 18.7 (a), we find that minimum radius of rotation,

$$r_1 = BG = BP \sin 30^\circ = 0.2 \times 0.5 = 0.1 \text{ m}$$

Height of the governor,

$$h_1 = PG = BP \cos 30^\circ = 0.2 \times 0.866 = 0.1732 \text{ m}$$



A series of hydel generators.

Note : This picture is given as additional information and is not a direct example of the current chapter.

664 • Theory of Machines

and  $DG = \sqrt{(BD)^2 - (BG)^2} = \sqrt{(0.25)^2 - (0.1)^2} = 0.23 \text{ m}$

$\therefore \tan \beta_1 = BG/DG = 0.1/0.23 = 0.4348$

and  $\tan \alpha_1 = \tan 30^\circ = 0.5774$

$\therefore q_1 = \frac{\tan \beta_1}{\tan \alpha_1} = \frac{0.4348}{0.5774} = 0.753$

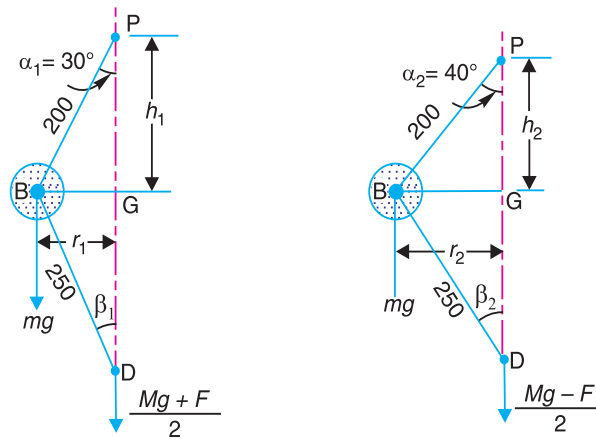

All dimensions in mm.

(a) Minimum position. (b) Maximum position.

Fig. 18.7

We know that when the sleeve moves downwards, the frictional force ( $F$ ) acts upwards and the minimum speed is given by

$$(N_1)^2 = \frac{m \cdot g + \left( \frac{M \cdot g - F}{2} \right) (1 + q_1)}{m \cdot g} \times \frac{895}{h_1}$$

$$= \frac{2 \times 9.81 + \left( \frac{15 \times 9.81 - 24}{2} \right) (1 + 0.753)}{2 \times 9.81} \times \frac{895}{0.1732} = 33596$$

$\therefore N_1 = 183.3 \text{ r.p.m.}$

Now from Fig. 18.7 (b), we find that maximum radius of rotation,

$$r_2 = BG = BP \sin 40^\circ = 0.2 \times 0.643 = 0.1268 \text{ m}$$

Height of the governor,

$$h_2 = PG = BP \cos 40^\circ = 0.2 \times 0.766 = 0.1532 \text{ m}$$

and  $DG = \sqrt{(BD)^2 - (BG)^2} = \sqrt{(0.25)^2 - (0.1268)^2} = 0.2154 \text{ m}$

$\therefore \tan \beta_2 = BG/DG = 0.1268 / 0.2154 = 0.59$

and  $\tan \alpha_2 = \tan 40^\circ = 0.839$

$\therefore q_2 = \frac{\tan \beta_2}{\tan \alpha_2} = \frac{0.59}{0.839} = 0.703$

We know that when the sleeve moves upwards, the frictional force ( $F$ ) acts downwards and the maximum speed is given by

$$(N_2)^2 = \frac{m \cdot g + \left(\frac{m \cdot g + F}{2}\right)(1 + q_2)}{m \cdot g} \times \frac{895}{h_2}$$

$$= \frac{2 \times 9.81 + \left(\frac{15 \times 9.81 + 24}{2}\right)(1 + 0.703)}{2 \times 9.81} \times \frac{895}{0.1532} = 49\,236$$

∴  $N_2 = 222$  r.p.m.

We know that range of speed

$$= N_2 - N_1 = 222 - 183.3 = 38.7 \text{ r.p.m. Ans.}$$

**Example 18.5.** A Porter governor has all four arms 250 mm long. The upper arms are attached on the axis of rotation and the lower arms are attached to the sleeve at a distance of 30 mm from the axis. The mass of each ball is 5 kg and the sleeve has a mass of 50 kg. The extreme radii of rotation are 150 mm and 200 mm. Determine the range of speed of the governor.

**Solution.** Given :  $BP = BD = 250$  mm ;  $DH = 30$  mm ;  $m = 5$  kg ;  $M = 50$  kg ;  $r_1 = 150$  mm ;  $r_2 = 200$  mm

First of all, let us find the minimum and maximum speed of the governor. The minimum and maximum position of the governor is shown in Fig. 18.8 (a) and (b) respectively.

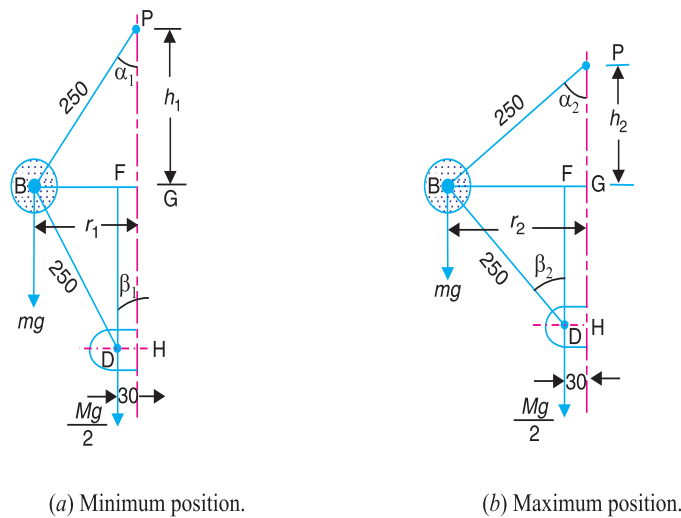

Fig. 18.8

Let  $N_1$  = Minimum speed when  $r_1 = BG = 150$  mm ; and  
 $N_2$  = Maximum speed when  $r_2 = BG = 200$  mm.

From Fig. 18.8 (a), we find that height of the governor,

$$h_1 = PG = \sqrt{(BP)^2 - (BG)^2} = \sqrt{(250)^2 - (150)^2} = 200 \text{ mm} = 0.2 \text{ m}$$

$$BF = BG - FG = 150 - 30 = 120 \text{ mm} \quad \dots (\because FG = DH)$$

666 • Theory of Machines

and  $DF = \sqrt{(DB)^2 - (BF)^2} = \sqrt{(250)^2 - (120)^2} = 219 \text{ mm}$

$\therefore \tan \alpha_1 = BG/PG = 150 / 200 = 0.75$

and  $\tan \beta_1 = BF/DF = 120/219 = 0.548$

$\therefore q_1 = \frac{\tan \beta_1}{\tan \alpha_1} = \frac{0.548}{0.75} = 0.731$

We know that  $(N_1)^2 = \frac{m + \frac{M}{2}(1 + q_1)}{m} \times \frac{895}{h_1} = \frac{5 + \frac{50}{2}(1 + 0.731)}{5} \times \frac{895}{0.2} = 43206$

$\therefore N_1 = 208 \text{ r.p.m.}$

From Fig. 18.8(b), we find that height of the governor,

$$h_2 = PG = \sqrt{(BP)^2 - (BG)^2} = \sqrt{(250)^2 - (200)^2} = 150 \text{ mm} = 0.15 \text{ m}$$

$$BF = BG - FG = 200 - 30 = 170 \text{ mm}$$

and  $DF = \sqrt{(DB)^2 - (BF)^2} = \sqrt{(250)^2 - (170)^2} = 183 \text{ mm}$

$\therefore \tan \alpha_2 = BG/PG = 200/150 = 1.333$

and  $\tan \beta_2 = BF/DF = 170/183 = 0.93$

$\therefore q_2 = \frac{\tan \beta_2}{\tan \alpha_2} = \frac{0.93}{1.333} = 0.7$

We know that

$$(N_2)^2 = \frac{m + \frac{M}{2}(1 + q_2)}{m} \times \frac{895}{h_2} = \frac{5 + \frac{50}{2}(1 + 0.7)}{5} \times \frac{895}{0.15} = 56683$$

$\therefore N_2 = 238 \text{ r.p.m.}$

We know that range of speed

$$= N_2 - N_1 = 238 - 208 = 30 \text{ r.p.m. Ans.}$$

**Example 18.6.** The arms of a Porter governor are 300 mm long. The upper arms are pivoted on the axis of rotation. The lower arms are attached to a sleeve at a distance of 40 mm from the axis of rotation. The mass of the load on the sleeve is 70 kg and the mass of each ball is 10 kg. Determine the equilibrium speed when the radius of rotation of the balls is 200 mm. If the friction is equivalent to a load of 20 N at the sleeve, what will be the range of speed for this position ?

**Solution.** Given :  $BP = BD = 300 \text{ mm}$  ;  $DH = 40 \text{ mm}$  ;  $M = 70 \text{ kg}$  ;  $m = 10 \text{ kg}$  ;  $r = BG = 200 \text{ mm}$

**Equilibrium speed when the radius of rotation  $r = BG = 200 \text{ mm}$**

Let  $N$  = Equilibrium speed.

The equilibrium position of the governor is shown in Fig. 18.9. From the figure, we find that height of the governor,

$$h = PG = \sqrt{(BP)^2 - (BG)^2} = \sqrt{(300)^2 - (200)^2} = 224 \text{ mm} \\ = 0.224 \text{ m}$$

$$\therefore BF = BG - FG = 200 - 40 = 160$$

$$\dots (\because FG = DH)$$

$$\text{and } DF = \sqrt{(DB)^2 - (BF)^2} = \sqrt{(300)^2 - (160)^2} = 254 \text{ mm}$$

$$\therefore \tan \alpha = BG/PG = 200 / 224 = 0.893$$

$$\text{and } \tan \beta = BF/DF = 160 / 254 = 0.63$$

$$\therefore q = \frac{\tan \beta}{\tan \alpha} = \frac{0.63}{0.893} = 0.705$$

We know that

$$N_2 = \frac{m + \frac{M}{2}(1 + q)}{m} \times \frac{895}{h}$$

$$= \frac{10 + \frac{70}{2}(1 + 0.705)}{10} \times \frac{895}{0.224} = 27\ 840$$

$$\therefore N_2 = 167 \text{ r.p.m. Ans.}$$

**Range of speed when friction is equivalent to load of 20 N at the sleeve (i.e. when  $F = 20 \text{ N}$ )**

Let  $N_1$  = Minimum equilibrium speed, and

$N_2$  = Maximum equilibrium speed.

We know that when the sleeve moves downwards, the frictional force ( $F$ ) acts upwards and the minimum equilibrium speed is given by

$$(N_1)^2 = \frac{m \cdot g + \left(\frac{M \cdot g - F}{2}\right)(1 + q)}{m \cdot g} \times \frac{895}{h}$$

$$= \frac{10 \times 9.81 + \left(\frac{70 \times 9.81 - 20}{2}\right)(1 + 0.705)}{10 \times 9.81} \times \frac{895}{0.224} = 27\ 144$$

$$\therefore N_1 = 164.8 \text{ r.p.m.}$$

We also know that when the sleeve moves upwards, the frictional force ( $F$ ) acts downwards and the maximum equilibrium speed is given by

$$(N_2)^2 = \frac{m \cdot g + \left(\frac{M \cdot g + F}{2}\right)(1 + q)}{m \cdot g} \times \frac{895}{h}$$

$$= \frac{10 \times 9.81 + \left(\frac{70 \times 9.81 + 20}{2}\right)(1 + 0.705)}{10 \times 9.81} \times \frac{895}{0.224} = 28\ 533$$

$$\therefore N_2 = 169 \text{ r.p.m.}$$

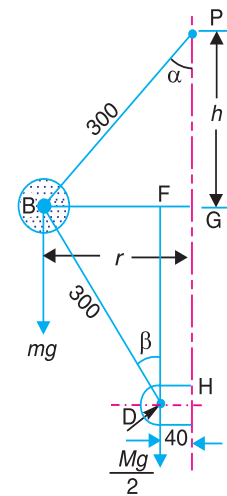

All dimensions in mm.

**Fig. 18.9**



An 18th century governor.

668 • Theory of Machines

We know that range of speed

$$= N_2 - N_1 = 169 - 164.8 = 4.2 \text{ r.p.m. Ans.}$$

**Example 18.7.** A loaded Porter governor has four links each 250 mm long, two revolving masses each of 3 kg and a central dead weight of mass 20 kg. All the links are attached to respective sleeves at radial distances of 40 mm from the axis of rotation. The masses revolve at a radius of 150 mm at minimum speed and at a radius of 200 mm at maximum speed. Determine the range of speed.

**Solution.** Given :  $BP = BD = 250 \text{ mm}$  ;  $m = 3 \text{ kg}$  ;  $M = 20 \text{ kg}$  ;  $PQ = DH = 40 \text{ mm}$  ;  $r_1 = 150 \text{ mm}$  ;  $r_2 = 200 \text{ mm}$

First of all, let us find the minimum and maximum speed of the governor.

The minimum and maximum position of the governor is shown in Fig. 18.10 (a) and (b) respectively.

Let  $N_1 =$  Minimum speed when  $r_1 = BG = 150 \text{ mm}$ , and

$N_2 =$  Minimum speed when  $r_2 = BG = 200 \text{ mm}$ .

From Fig. 18.10 (a), we find that

$$BF = BG - FG = 150 - 40 = 110 \text{ mm}$$

and  $\sin \alpha_1 = BF / BP = 110 / 250 = 0.44$  or  $\alpha_1 = 26.1^\circ$

$\therefore$  Height of the governor,

$$h_1 = OG = BG / \tan \alpha_1 = 150 / \tan 26.1^\circ = 306 \text{ mm} = 0.306 \text{ m}$$

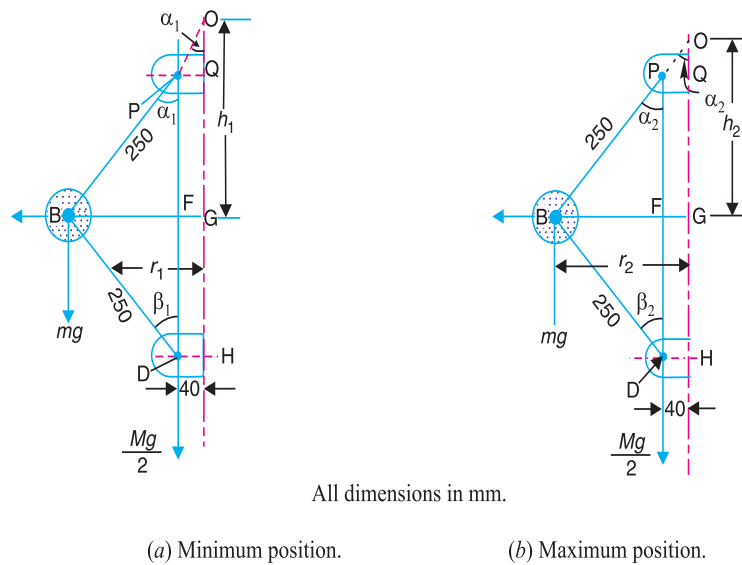

Fig. 18.10

Since all the links are attached to respective sleeves at equal distances (*i.e.* 40 mm) from the axis of rotation, therefore

$$\tan \alpha_1 = \tan \beta_1 \quad \text{or} \quad q = 1$$

We know that  $(N_1)^2 = \frac{m + M}{m} \times \frac{895}{h_1} = \frac{3 + 20}{3} \times \frac{895}{0.306} = 22424$

$$N_1 = 150 \text{ r.p.m.}$$



Now from Fig. 18.10 (b), we find that

$$BF = BG - FG = 200 - 40 = 160 \text{ mm}$$

and  $\sin \alpha_2 = BF/BP = 160 / 250 = 0.64$  or  $\beta_2 = 39.8^\circ$

∴ Height of the governor,

$$h_2 = OG = BG / \tan \alpha_2 = 200 / \tan 39.8^\circ = 240 \text{ mm} = 0.24 \text{ m}$$

In this case also,

$$\tan \alpha_2 = \tan \beta_2 \quad \text{or} \quad q = 1$$

We know that  $(N_2)^2 = \frac{m + M}{m} \times \frac{895}{h_2} = \frac{3 + 20}{3} \times \frac{895}{0.24} = 28\,590$

∴  $N_2 = 169 \text{ r.p.m.}$

We know that range of speed

$$= N_2 - N_1 = 169 - 150 = 19 \text{ r.p.m. Ans.}$$

**Example 18.8.** All the arms of a Porter governor are 178 mm long and are hinged at a distance of 38 mm from the axis of rotation. The mass of each ball is 1.15 kg and mass of the sleeve is 20 kg. The governor sleeve begins to rise at 280 r.p.m. when the links are at an angle of 30° to the vertical. Assuming the friction force to be constant, determine the minimum and maximum speed of rotation when the inclination of the arms to the vertical is 45°.

**Solution.** Given :  $BP = BD = 178 \text{ mm}$  ;  $PQ = DH = 38 \text{ mm}$  ;  
 $m = 1.15 \text{ kg}$  ;  $M = 20 \text{ kg}$  ;  $N = 280 \text{ r.p.m.}$  ;  $\alpha = \beta = 30^\circ$

First of all, let us find the friction force ( $F$ ). The equilibrium position of the governor when the lines are at 30° to vertical, is shown in Fig. 18.11. From the figure, we find that radius of rotation,

$$r = BG = BF + FG = BP \times \sin \alpha + FG$$

$$= 178 \sin 30^\circ + 38 = 127 \text{ mm}$$

and height of the governor,

$$h = BG / \tan \alpha$$

$$= 127 / \tan 30^\circ = 220 \text{ mm} = 0.22 \text{ m}$$

We know that

$$N^2 = \frac{m \cdot g + (Mg \pm F)}{m \cdot g} \times \frac{895}{h}$$

... (∴  $\tan \alpha = \tan \beta$  or  $q = 1$ )

$$(280)^2 = \frac{1.15 \times 9.81 + 20 \times 9.81 \pm F}{1.15 \times 9.81} \times \frac{895}{0.22}$$

or  $\pm F = \frac{(280)^2 \times 1.15 \times 9.81 \times 0.22}{895} - 1.15 \times 9.81 - 20 \times 9.81$

$$= 217.5 - 11.3 - 196.2 = 10 \text{ N}$$

We know that radius of rotation when inclination of the arms to the vertical is 45 (i.e. when  $\alpha = \beta = 45^\circ$ ),

$$r = BG = BF + FG = BP \times \sin \alpha + FG$$

$$= 178 \sin 45^\circ + 38 = 164 \text{ mm}$$

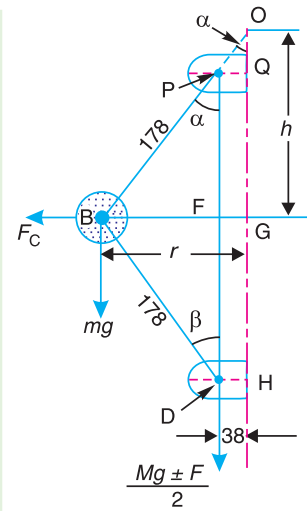

All dimensions in mm.

Fig. 18.11

**670 • Theory of Machines**

and height of the governor,

$$h = BG / \tan \alpha = 164 / \tan 45^\circ = 164 \text{ mm} = 0.164 \text{ m}$$

Let  $N_1$  = Minimum speed of rotation, and

$N_2$  = Maximum speed of rotation.

We know that

$$\begin{aligned} (N_1)^2 &= \frac{m \cdot g + (M \cdot g - F)}{m \cdot g} \times \frac{895}{h} \\ &= \frac{1.15 \times 9.81 + (20 \times 9.81 - 10)}{1.15 \times 9.81} \times \frac{895}{0.164} = 95\,382 \end{aligned}$$

$$\therefore N_1 = 309 \text{ r.p.m. Ans.}$$

and

$$\begin{aligned} (N_2)^2 &= \frac{m \cdot g + (M \cdot g + F)}{m \cdot g} \times \frac{895}{h} \\ &= \frac{1.15 \times 9.81 + (20 \times 9.81 + 10)}{1.15 \times 9.81} \times \frac{895}{0.164} = 105\,040 \end{aligned}$$

$$N_2 = 324 \text{ r.p.m. Ans.}$$

**18.7. Proell Governor**

The Proell governor has the balls fixed at  $B$  and  $C$  to the extension of the links  $DF$  and  $EG$ , as shown in Fig. 18.12 (a). The arms  $FP$  and  $GQ$  are pivoted at  $P$  and  $Q$  respectively.

Consider the equilibrium of the forces on one-half of the governor as shown in Fig. 18.12 (b). The instantaneous centre ( $I$ ) lies on the intersection of the line  $PF$  produced and the line from  $D$  drawn perpendicular to the spindle axis. The perpendicular  $BM$  is drawn on  $ID$ .

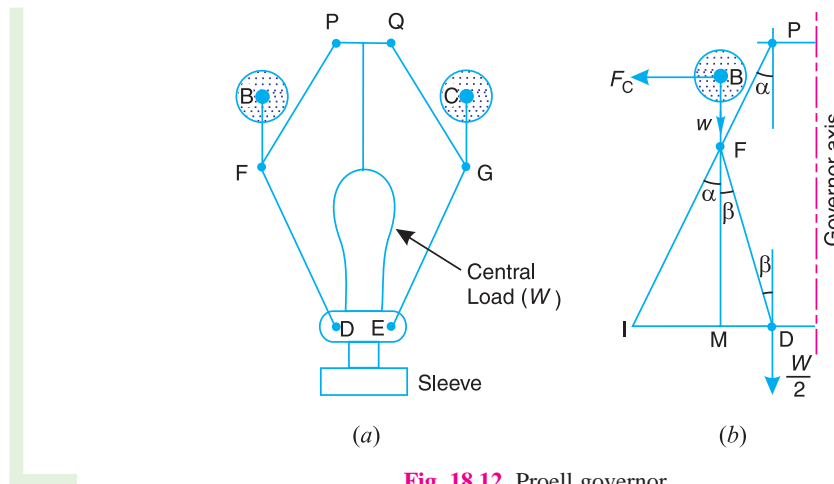

**Fig. 18.12.** Proell governor.

Taking moments about  $I$ , using the same notations as discussed in Art. 18.6 (Porter governor),

$$F_C \times BM = w \times IM + \frac{W}{2} \times ID = m \cdot g \times IM + \frac{M \cdot g}{2} \times ID \quad \dots (i)$$

$$\therefore F_C = m \cdot g \times \frac{IM}{BM} + \frac{M \cdot g}{2} \left( \frac{IM + MD}{BM} \right) \quad \dots (\because ID = IM + MD)$$

Multiplying and dividing by  $FM$ , we have

$$\begin{aligned} F_C &= \frac{FM}{BM} \left[ m \cdot g \times \frac{IM}{FM} + \frac{M \cdot g}{2} \left( \frac{IM}{FM} + \frac{MD}{FM} \right) \right] \\ &= \frac{FM}{BM} \left[ m \cdot g \times \tan \alpha + \frac{M \cdot g}{2} (\tan \alpha + \tan \beta) \right] \\ &= \frac{FM}{BM} \times \tan \alpha \left[ m \cdot g + \frac{M \cdot g}{2} \left( 1 + \frac{\tan \beta}{\tan \alpha} \right) \right] \end{aligned}$$

We know that  $F_C = m \cdot \omega^2 r$ ;  $\tan \alpha = \frac{r}{h}$  and  $q = \frac{\tan \beta}{\tan \alpha}$

$$\therefore m \cdot \omega^2 \cdot r = \frac{FM}{BM} \times \frac{r}{h} \left[ m \cdot g + \frac{M \cdot g}{2} (1 + q) \right]$$

and

$$\omega^2 = \frac{FM}{BM} \left[ \frac{m + \frac{M}{2} (1 + q)}{m} \right] \frac{g}{h} \quad \dots (ii)$$

Substituting  $\omega = 2\pi N/60$ , and  $g = 9.81 \text{ m/s}^2$ , we get

$$N^2 = \frac{FM}{BM} \left[ \frac{m + \frac{M}{2} (1 + q)}{m} \right] \frac{895}{h} \quad \dots (iii)$$

**Notes : 1.** The equation (i) may be applied to any given configuration of the governor.

**2.** Comparing equation (iii) with the equation (v) of the Porter governor (Art. 18.6), we see that the equilibrium speed reduces for the given values of  $m$ ,  $M$  and  $h$ . Hence in order to have the same equilibrium speed for the given values of  $m$ ,  $M$  and  $h$ , balls of smaller masses are used in the Proell governor than in the Porter governor.

**3.** When  $\alpha = \beta$ , then  $q = 1$ . Therefore equation (iii) may be written as

$$N^2 = \frac{FM}{BM} \left( \frac{m + M}{m} \right) \frac{895}{h} \quad (h \text{ being in metres}) \dots (iv)$$

**Example 18.9.** A Proell governor has equal arms of length 300 mm. The upper and lower ends of the arms are pivoted on the axis of the governor. The extension arms of the lower links are each 80 mm long and parallel to the axis when the radii of rotation of the balls are 150 mm and 200 mm. The mass of each ball is 10 kg and the mass of the central load is 100 kg. Determine the range of speed of the governor.

**Solution.** Given :  $PF = DF = 300 \text{ mm}$  ;  $BF = 80 \text{ mm}$  ;  $m = 10 \text{ kg}$  ;  $M = 100 \text{ kg}$  ;  $r_1 = 150 \text{ mm}$ ;  $r_2 = 200 \text{ mm}$

First of all, let us find the minimum and maximum speed of the governor. The minimum and maximum position of the governor is shown in Fig. 18.13.

Let  $N_1 =$  Minimum speed when radius of rotation,  $r_1 = FG = 150 \text{ mm}$  ; and  
 $N_2 =$  Maximum speed when radius of rotation,  $r_2 = FG = 200 \text{ mm}$ .

From Fig. 18.13 (a), we find that height of the governor,

$$h_1 = PG = \sqrt{(PF)^2 - (FG)^2} = \sqrt{(300)^2 - (150)^2} = 260 \text{ mm} = 0.26 \text{ m}$$

**672 • Theory of Machines**

and

$$FM = GD = PG = 260 \text{ mm} = 0.26 \text{ m}$$

$$\therefore BM = BF + FM = 80 + 260 = 340 \text{ mm} = 0.34 \text{ m}$$

We know that  $(N_1)^2 = \frac{FM}{BM} \left( \frac{m+M}{m} \right) \frac{895}{h_1} \dots (\because \alpha = \beta \text{ or } q = 1)$

$$= \frac{0.26}{0.34} \left( \frac{10+100}{10} \right) \frac{895}{0.26} = 28\,956 \text{ or } N_1 = 170 \text{ r.p.m.}$$

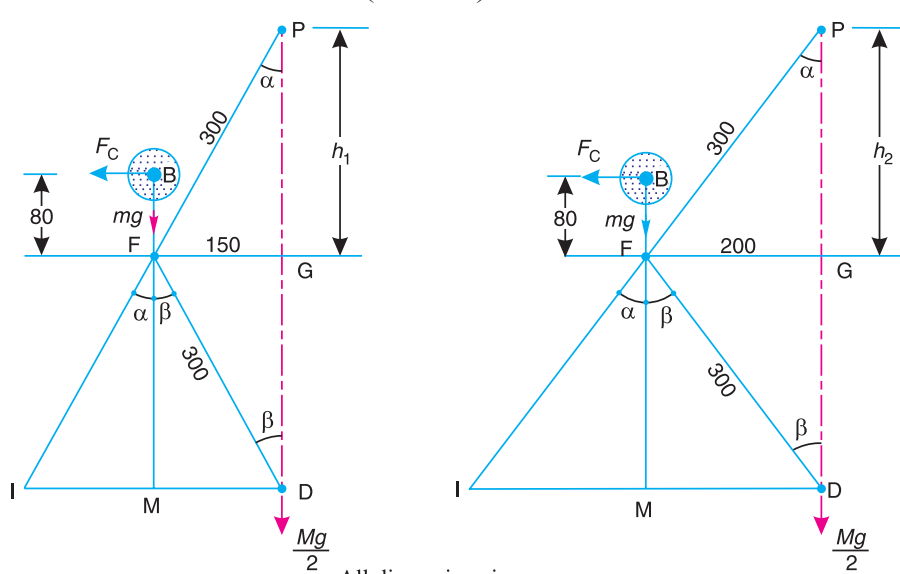

All dimensions in mm.

(a) Minimum position.

(a) Maximum position.

**Fig. 18.13**

Now from Fig. 18.13 (b), we find that height of the governor,

$$h_2 = PG = \sqrt{(PF)^2 - (FG)^2} = \sqrt{(300)^2 - (200)^2} = 224 \text{ mm} = 0.224 \text{ m}$$

and

$$FM = GD = PG = 224 \text{ mm} = 0.224 \text{ m}$$

$$\therefore BM = BF + FM = 80 + 224 = 304 \text{ mm} = 0.304 \text{ m}$$

We know that  $(N_2)^2 = \frac{FM}{BM} \left( \frac{m+M}{m} \right) \frac{895}{h_2} \dots (\because \alpha = \beta \text{ or } q = 1)$

$$= \frac{0.224}{0.304} \left( \frac{10+100}{10} \right) \frac{895}{0.224} = 32\,385 \text{ or } N_2 = 180 \text{ r.p.m.}$$

We know that range of speed

$$= N_2 - N_1 = 180 - 170 = 10 \text{ r.p.m. Ans.}$$

**Note :** The example may also be solved as discussed below :

From Fig. 18.13 (a), we find that

$$\sin \alpha = \sin \beta = 150 / 300 = 0.5 \quad \text{or} \quad \alpha = \beta = 30^\circ$$

and

$$MD = FG = 150 \text{ mm} = 0.15 \text{ m}$$

$$FM = FD \cos \beta = 300 \cos 30^\circ = 260 \text{ mm} = 0.26 \text{ m}$$

$$IM = FM \tan \alpha = 0.26 \tan 30^\circ = 0.15 \text{ m}$$

$$BM = BF + FM = 80 + 260 = 340 \text{ mm} = 0.34 \text{ m}$$

$$ID = IM + MD = 0.15 + 0.15 = 0.3 \text{ m}$$

We know that centrifugal force,

$$F_C = m (\omega_1)^2 r_1 = 10 \left( \frac{2\pi N_1}{60} \right)^2 0.15 = 0.0165 (N_1)^2$$

Now taking moments about point  $I$ ,

$$F_C \times BM = m \cdot g \times IM + \frac{M \cdot g}{2} \times ID$$

or  $0.0165 (N_1)^2 \cdot 0.34 = 10 \times 9.81 \times 0.15 + \frac{100 \times 9.81}{2} \times 0.3$

$$0.0056 (N_1)^2 = 14.715 + 147.15 = 161.865$$

$$\therefore (N_1)^2 = \frac{161.865}{0.0056} = 28904 \quad \text{or} \quad N_1 = 170 \text{ r.p.m.}$$

Similarly  $N_2$  may be calculated.



An overview of a combined cycle power plant. Governors are used in power plants to control the flow of working fluids.

Note : This picture is given as additional information and is not a direct example of the current chapter.

**Example 18.10.** A governor of the Proell type has each arm 250 mm long. The pivots of the upper and lower arms are 25 mm from the axis. The central load acting on the sleeve has a mass of 25 kg and the each rotating ball has a mass of 3.2 kg. When the governor sleeve is in mid-position, the extension link of the lower arm is vertical and the radius of the path of rotation of the masses is 175 mm. The vertical height of the governor is 200 mm.

If the governor speed is 160 r.p.m. when in mid-position, find : **1.** length of the extension link; and **2.** tension in the upper arm.

**674 • Theory of Machines**

**Solution.** Given :  $PF = DF = 250 \text{ mm} = 0.25 \text{ m}$  ;  $PQ = DH = KG = 25 \text{ mm} = 0.025 \text{ m}$  ;  
 $M = 25 \text{ kg}$  ;  $m = 3.2 \text{ kg}$  ;  $r = FG = 175 \text{ mm} = 0.175 \text{ m}$  ;  $h = QG = PK = 200 \text{ mm} = 0.2 \text{ m}$  ;  $N = 160 \text{ r.p.m.}$

**1. Length of the extension link**

Let  $BF =$  Length of the extension link.

The Proell governor in its mid-position is shown in Fig. 18.14.

From the figure, we find that

$$FM = GH = QG = 200 \text{ mm} = 0.2 \text{ m}$$

We know that

$$N^2 = \frac{FM}{BM} \left( \frac{m + M}{m} \right) \frac{895}{h}$$

... ( $\because \alpha = \beta$  or  $q = 1$ )

$$(160)^2 = \frac{0.2}{BM} \left( \frac{3.2 + 25}{3.2} \right) \frac{895}{0.2} = \frac{7887}{BM}$$

$$\therefore BM = 7887 / (160)^2 = 0.308 \text{ m}$$

From Fig. 18.14,

$$BF = BM - FM = 0.308 - 0.2 = 0.108 \text{ m} = 108 \text{ mm} \text{ Ans.}$$

**2. Tension in the upper arm**

Let  $T_1 =$  Tension in the upper arm.

$$PK = \sqrt{(PF)^2 - (FK)^2} = \sqrt{(PF)^2 - (FG - KG)^2}$$

$$= \sqrt{(250)^2 - (175 - 25)^2} = 200 \text{ mm}$$

$$\cos \alpha = PK/PF = 200/250 = 0.8$$

and  $T_1 \cos \alpha = mg + \frac{Mg}{2} = 3.2 \times 9.81 + \frac{25 \times 9.81}{2} = 154 \text{ N}$

$$\therefore T_1 = \frac{154}{\cos \alpha} = \frac{154}{0.8} = 192.5 \text{ N} \text{ Ans.}$$

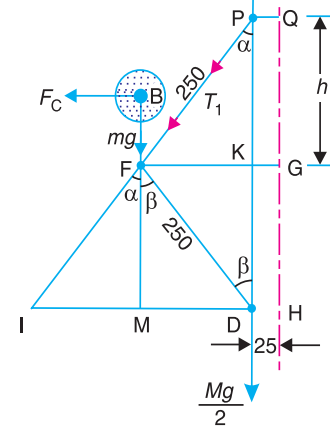

**Fig. 18.14.** All dimensions in mm.

**Example 18.11.** The following particulars refer to a Proell governor with open arms :

Length of all arms = 200 mm ; distance of pivot of arms from the axis of rotation = 40 mm ; length of extension of lower arms to which each ball is attached = 100 mm ; mass of each ball = 6 kg and mass of the central load = 150 kg. If the radius of rotation of the balls is 180 mm when the arms are inclined at an angle of  $40^\circ$  to the axis of rotation, find the equilibrium speed for the above configuration.

**Solution.** Given :  $PF = DF = 200 \text{ mm}$  ;  $PQ = DK = HG = 40 \text{ mm}$  ;  $BF = 100 \text{ mm}$  ;  $m = 6 \text{ kg}$  ;  $M = 150 \text{ kg}$  ;  
 $r = JG = 180 \text{ mm} = 0.18 \text{ m}$  ;  $\alpha = \beta = 40^\circ$

Let  $N =$  Equilibrium speed.

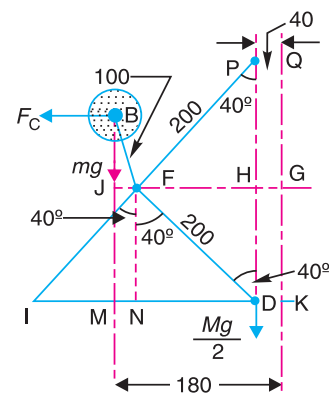

**Fig. 18.15.** All dimensions in mm.

From the equilibrium position of the governor, as shown in Fig. 18.15, we find that

$$\begin{aligned} PH &= PF \times \cos 40^\circ \\ &= 200 \times 0.766 = 153.2 \text{ mm} \\ &= 0.1532 \text{ m} \end{aligned}$$

and  $FH = PF \times \sin 40^\circ = 200 \times 0.643 = 128.6 \text{ mm}$

$$\therefore JF = JG - HG - FH = 180 - 40 - 128.6 = 11.4 \text{ mm}$$

and  $BJ = \sqrt{(BF)^2 - (JF)^2} = \sqrt{(100)^2 - (11.4)^2} = 99.4 \text{ mm}$

We know that  $BM = BJ + JM = 99.4 + 153.2 = 252.6 \text{ mm}$  ... ( $\because JM = HD = PH$ )

$$IM = IN - NM = FH - JF = 128.6 - 11.4 = 117.2 \text{ mm}$$

... ( $\because IN = ND = FH$ )

and  $ID = IN + ND = 2 \times IN = 2 \times FH = 2 \times 128.6 = 257.2 \text{ mm}$

Now taking moments about the instantaneous centre  $I$ ,

$$F_C \times BM = m \cdot g \times IM + \frac{M \cdot g}{2} \times ID$$

$$F_C \times 252.6 = 6 \times 9.81 \times 117.2 + \frac{150 \times 9.81}{2} \times 257.2 = 196\,125$$

$$\therefore F_C = \frac{196\,125}{252.6} = 776.4 \text{ N}$$

We know that centrifugal force ( $F_C$ ),

$$776.4 = m \cdot \omega^2 \cdot r = 6 \left( \frac{2\pi N}{60} \right)^2 0.18 = 0.012 N^2$$

$$\therefore N^2 = \frac{776.4}{0.012} = 64\,700 \quad \text{or} \quad N = 254 \text{ r.p.m. Ans.}$$

**Example 18.12.** A Proell governor has all four arms of length 305 mm. The upper arms are pivoted on the axis of rotation and the lower arms are attached to a sleeve at a distance of 38 mm from the axis. The mass of each ball is 4.8 kg and are attached to the extension of the lower arms which are 102 mm long. The mass on the sleeve is 45 kg. The minimum and maximum radii of governor are 165 mm and 216 mm. Assuming that the extensions of the lower arms are parallel to the governor axis at the minimum radius, find the corresponding equilibrium speeds.

**Solution.** Given :  $PF = DF = 305 \text{ mm}$  ;  $DH = 38 \text{ mm}$  ;  $BF = 102 \text{ mm}$  ;  $m = 4.8 \text{ kg}$  ;  $M = 54 \text{ kg}$

**Equilibrium speed at the minimum radius of governor**

The radius of the governor is the distance of the point of intersection of the upper and lower arms from the governor axis. When the extensions of the lower arms are parallel to the governor axis, then the radius of the governor ( $FG$ ) is equal to the radius of rotation ( $r_1$ ).

**676 • Theory of Machines**

The governor configuration at the minimum radius (i.e. when  $FG = 165$  mm) is shown in Fig. 18.16.

Let  $N_1$  = Equilibrium speed at the minimum radius i.e. when  $FG = r_1 = 165$  mm.

From Fig. 18.16, we find that

$$\sin \alpha = \frac{FG}{FP} = \frac{165}{305} = 0.541$$

$$\therefore \alpha = 32.75^\circ$$

and  $\tan \alpha = \tan 32.75^\circ = 0.6432$

Also 
$$\sin \beta = \frac{FK}{DF} = \frac{FG - KG}{DF}$$

$$= \frac{165 - 38}{305} = 0.4164$$

$$\therefore \beta = 24.6^\circ$$

and  $\tan \beta = \tan 24.6^\circ = 0.4578$

We know that

$$q = \frac{\tan \beta}{\tan \alpha} = \frac{0.4578}{0.6432} = 0.712$$

From Fig. 18.16, we find that height of the governor,

$$h = PG = \sqrt{(PF)^2 - (FG)^2} = \sqrt{(305)^2 - (165)^2} = 256.5 \text{ mm} = 0.2565 \text{ m}$$

$$MD = FK = FG - KG = 165 - 38 = 127 \text{ mm}$$

$$\therefore FM = \sqrt{(DF)^2 - (MD)^2} = \sqrt{(305)^2 - (127)^2} = 277 \text{ mm} = 0.277 \text{ m}$$

and  $BM = BF + FM = 102 + 277 = 379 \text{ mm} = 0.379 \text{ m}$

We know that

$$(N_1)^2 = \frac{FM}{BM} \left[ \frac{m + \frac{M}{2}(1+q)}{m} \right] \frac{895}{h}$$

$$= \frac{0.277}{0.379} \left[ \frac{4.8 + \frac{54}{2}(1+0.712)}{4.8} \right] \frac{895}{0.2565} = 27\ 109$$

$$\therefore N_1 = 165 \text{ r.p.m. Ans.}$$

**Note :** The value of  $N_1$  may also be obtained by drawing the governor configuration to some suitable scale and measuring the distances  $BM$ ,  $IM$  and  $ID$ . Now taking moments about point  $I$ ,

$$F_C \times BM = m.g \times IM + \frac{M.g}{2} \times ID,$$

where  $F_C = \text{Centrifugal force} = m(\omega_1)^2 r_1 = m \left( \frac{2\pi N_1}{60} \right)^2 r_1$

**Equilibrium speed at the maximum radius of governor**

Let  $N_2$  = Equilibrium speed at the maximum radius of governor, i.e. when  $F_1G_1 = r_2 = 216$  mm.

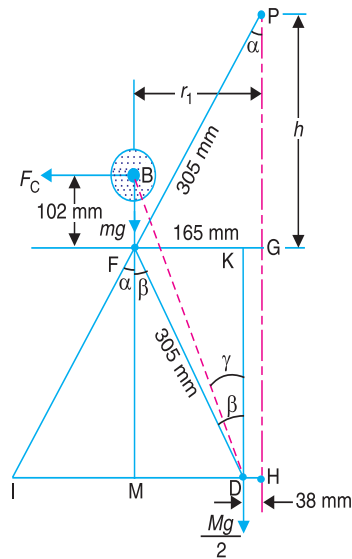

**Fig. 18.16**



First of all, let us find the values of  $BD$  and  $\gamma$  in Fig. 18.16. We know that

$$BD = \sqrt{(BM)^2 + (MD)^2} = \sqrt{(397)^2 + (127)^2} = 400 \text{ mm}$$

and  $\tan \gamma = MD/BM = 127/397 = 0.335$  or  $\gamma = 18.5^\circ$

The governor configuration at the maximum radius of  $F_1G_1 = 216 \text{ mm}$  is shown in Fig. 18.17. From the geometry of the figure,

$$\sin \alpha_1 = \frac{F_1 G_1}{F_1 F_1} = \frac{216}{305} = 0.7082$$

$\therefore \alpha_1 = 45.1^\circ$

$$\begin{aligned} \sin \beta_1 &= \frac{F_1 K_1}{F_1 D_1} = \frac{F_1 G_1 - K_1 G_1}{F_1 D_1} \\ &= \frac{216 - 38}{305} = 0.5836 \end{aligned}$$

$\therefore \beta_1 = 35.7^\circ$

Since the extension is rigidly connected to the lower arm (*i.e.*  $DFB$  or  $D_1F_1B_1$  is one continuous link) therefore  $B_1D_1$  and angle  $B_1D_1F_1$  do not change. In other words,

$$B_1D_1 = BD = 400 \text{ mm}$$

and  $\gamma - \beta = \gamma_1 - \beta_1$  or  $\gamma_1 = \gamma - \beta + \beta_1$   
 $= 18.5^\circ - 24.6^\circ + 35.7^\circ = 29.6^\circ$

$\therefore$  Radius of rotation,

$$\begin{aligned} r_2 &= M_1D_1 + D_1H_1 = B_1D_1 \times \sin \gamma_1 + 38 \text{ mm} \\ &= 400 \sin 29.6^\circ + 38 = 235.6 \text{ mm} = 0.2356 \text{ m} \end{aligned}$$

From Fig. 18.17, we find that

$$B_1M_1 = B_1D_1 \times \cos \gamma_1 = 400 \times \cos 29.6^\circ = 348 \text{ mm} = 0.348 \text{ m}$$

$$F_1N_1 = F_1D_1 \times \cos \beta_1 = 305 \times \cos 35.7^\circ = 248 \text{ mm} = 0.248 \text{ m}$$

$$I_1N_1 = F_1N_1 \times \tan \alpha_1 = 0.248 \times \tan 45.1^\circ = 0.249 \text{ m}$$

$$N_1D_1 = F_1D_1 \times \sin \beta_1 = 305 \times \sin 35.7^\circ = 178 \text{ mm} = 0.178 \text{ m}$$

$\therefore I_1D_1 = I_1N_1 + N_1D_1 = 0.249 + 0.178 = 0.427 \text{ m}$

$$M_1D_1 = B_1D_1 \sin \gamma_1 = 400 \sin 29.6^\circ = 198 \text{ mm} = 0.198 \text{ m}$$

$\therefore I_1M_1 = I_1D_1 - M_1D_1 = 0.427 - 0.198 = 0.229 \text{ m}$

We know that centrifugal force,

$$F_C = m(\omega_2)^2 r_2 = 4.8 \left( \frac{2\pi N_2}{60} \right)^2 0.2356 = 0.0124 (N_2)^2$$

Now taking moments about point  $I_1$ ,

$$F_C \times B_1M_1 = m \cdot g \times I_1M_1 + \frac{M \cdot g}{2} \times I_1D_1$$

$$0.0124 (N_2)^2 \times 0.348 = 4.8 \times 9.81 \times 0.229 + \frac{54 \times 9.81}{2} \times 0.427$$

$$0.0043 (N_2)^2 = 10.873 + 113.1 = 123.883$$

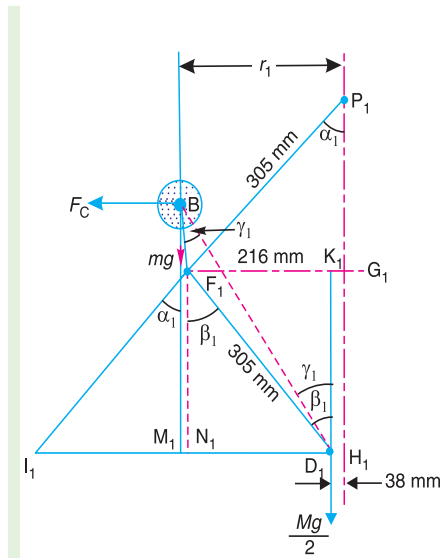

Fig. 18.17

678 • Theory of Machines

$$\therefore (N_2)^2 = \frac{123.883}{0.0043} = 28\,810 \quad \text{or} \quad N_2 = 170 \text{ r.p.m.} \quad \text{Ans.}$$

**Note :** The value of  $N_2$  may also be obtained by drawing the governor configuration to some suitable scale and measuring the distances  $B_1M_1$ ,  $I_1M_1$  and  $I_1D_1$ .

### 18.8. Hartnell Governor

A Hartnell governor is a spring loaded governor as shown in Fig. 18.18. It consists of two bell crank levers pivoted at the points  $O, O$  to the frame. The frame is attached to the governor spindle and therefore rotates with it. Each lever carries a ball at the end of the vertical arm  $OB$  and a roller at the end of the horizontal arm  $OR$ . A helical spring in compression provides equal downward forces on the two rollers through a collar on the sleeve. The spring force may be adjusted by screwing a nut up or down on the sleeve.

- Let
- $m$  = Mass of each ball in kg,
  - $M$  = Mass of sleeve in kg,
  - $r_1$  = Minimum radius of rotation in metres,
  - $r_2$  = Maximum radius of rotation in metres,
  - $\omega_1$  = Angular speed of the governor at minimum radius in rad/s,
  - $\omega_2$  = Angular speed of the governor at maximum radius in rad/s,
  - $S_1$  = Spring force exerted on the sleeve at  $\omega_1$  in newtons,
  - $S_2$  = Spring force exerted on the sleeve at  $\omega_2$  in newtons,

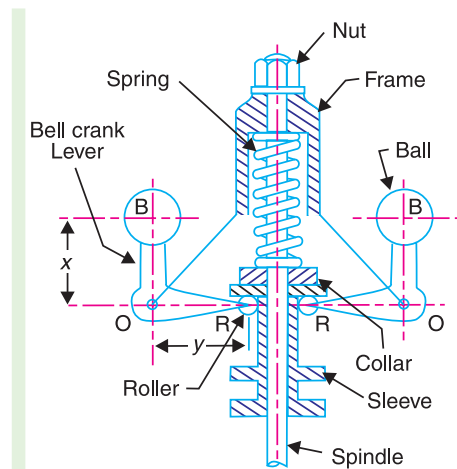

Fig. 18.18. Hartnell governor.

$$F_{C1} = \text{Centrifugal force at } \omega_1 \text{ in newtons} = m (\omega_1)^2 r_1,$$

$$F_{C2} = \text{Centrifugal force at } \omega_2 \text{ in newtons} = m (\omega_2)^2 r_2,$$

$s$  = Stiffness of the spring or the force required to compress the spring by one mm,

$x$  = Length of the vertical or ball arm of the lever in metres,

$y$  = Length of the horizontal or sleeve arm of the lever in metres, and

$r$  = Distance of fulcrum  $O$  from the governor axis or the radius of rotation when the governor is in mid-position, in metres.

Consider the forces acting at one bell crank lever. The minimum and maximum position is shown in Fig. 18.19. Let  $h$  be the compression of the spring when the radius of rotation changes from  $r_1$  to  $r_2$ .

For the minimum position *i.e.* when the radius of rotation changes from  $r$  to  $r_1$ , as shown in Fig. 18.19 (a), the compression of the spring or the lift of sleeve  $h_1$  is given by

$$\frac{h_1}{y} = \frac{a_1}{x} = \frac{r - r_1}{x} \quad \dots (i)$$

Similarly, for the maximum position *i.e.* when the radius of rotation changes from  $r$  to  $r_2$ , as shown in Fig. 18.19 (b), the compression of the spring or lift of sleeve  $h_2$  is given by

$$\frac{h_2}{y} = \frac{a_2}{x} = \frac{r_2 - r}{x} \quad \dots (ii)$$

Adding equations (i) and (ii),

$$\frac{h_1 + h_2}{y} = \frac{r_2 - r_1}{x} \quad \text{or} \quad \frac{h}{y} = \frac{r_2 - r_1}{x} \quad \dots (\because h = h_1 + h_2)$$

$$\therefore h = (r_2 - r_1) \frac{y}{x} \quad \dots \text{(iii)}$$

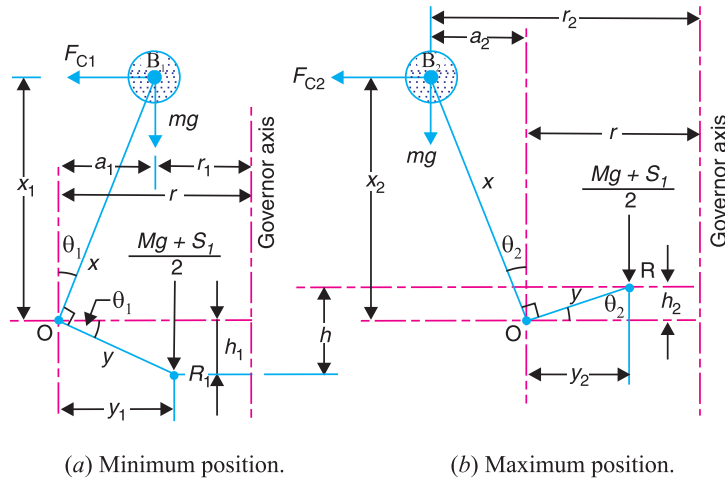

Fig. 18.19

Now for minimum position, taking moments about point  $O$ , we get

$$\frac{M \cdot g + S_1}{2} \times y_1 = F_{C1} \times x_1 - m \cdot g \times a_1$$

or 
$$M \cdot g + S_1 = \frac{2}{y_1} (F_{C1} \times x_1 - m \cdot g \times a_1) \quad \dots \text{(iv)}$$

Again for maximum position, taking moments about point  $O$ , we get

$$\frac{M \cdot g + S_2}{2} \times y_2 = F_{C2} \times x_2 + m \cdot g \times a_2$$

or 
$$M \cdot g + S_2 = \frac{2}{y_2} (F_{C2} \times x_2 + m \cdot g \times a_2) \quad \dots \text{(v)}$$

Subtracting equation (iv) from equation (v),

$$S_2 - S_1 = \frac{2}{y_2} (F_{C2} \times x_2 + m \cdot g \times a_2) - \frac{2}{y_1} (F_{C1} \times x_1 - m \cdot g \times a_1)$$

We know that

$$S_2 - S_1 = h \cdot s, \quad \text{and} \quad h = (r_2 - r_1) \frac{y}{x}$$

$$\therefore s = \frac{S_2 - S_1}{h} = \left( \frac{S_2 - S_1}{r_2 - r_1} \right) \frac{x}{y}$$

Neglecting the obliquity effect of the arms (*i.e.*  $x_1 = x_2 = x$ , and  $y_1 = y_2 = y$ ) and the moment due to weight of the balls (*i.e.*  $m \cdot g$ ), we have for minimum position,

$$\frac{M \cdot g + S_1}{2} \times y = F_{C1} \times x \quad \text{or} \quad M \cdot g + S_1 = 2F_{C1} \times \frac{x}{y} \quad \dots \text{(vi)}$$

## 680 • Theory of Machines

Similarly for maximum position,

$$\frac{M \cdot g + S_2}{2} \times y = F_{C2} \times x \quad \text{or} \quad M \cdot g + S_2 = 2F_{C2} \times \frac{x}{y} \quad \dots \text{(vii)}$$

Subtracting equation (vi) from equation (vii),

$$S_2 - S_1 = 2 (F_{C2} - F_{C1}) \frac{x}{y} \quad \dots \text{(viii)}$$

We know that

$$S_2 - S_1 = h \cdot s, \quad \text{and} \quad h = (r_2 - r_1) \frac{y}{x}$$

$$\therefore s = \frac{S_2 - S_1}{h} = 2 \left( \frac{F_{C2} - F_{C1}}{r_2 - r_1} \right) \left( \frac{x}{y} \right)^2 \quad \dots \text{(ix)}$$

**Notes : 1.** Unless otherwise stated, the obliquity effect of the arms and the moment due to the weight of the balls is neglected, in actual practice.

**2.** When friction is taken into account, the weight of the sleeve ( $M \cdot g$ ) may be replaced by ( $M \cdot g \pm F$ ).

**3.** The centrifugal force ( $F_C$ ) for any intermediate position (*i.e.* between the minimum and maximum position) at a radius of rotation ( $r$ ) may be obtained as discussed below :

Since the stiffness for a given spring is constant for all positions, therefore for minimum and intermediate position,

$$s = 2 \left( \frac{F_C - F_{C1}}{r - r_1} \right) \left( \frac{x}{y} \right)^2 \quad \dots \text{(x)}$$

and for intermediate and maximum position,

$$s = 2 \left( \frac{F_{C2} - F_C}{r_2 - r} \right) \left( \frac{x}{y} \right)^2 \quad \dots \text{(xi)}$$

$\therefore$  From equations (ix), (x) and (xi),

$$\frac{F_{C2} - F_{C1}}{r_2 - r_1} = \frac{F_C - F_{C1}}{r - r_1} = \frac{F_{C2} - F_C}{r_2 - r}$$

or

$$F_C = F_{C1} + (F_{C2} - F_{C1}) \left( \frac{r - r_1}{r_2 - r_1} \right) = F_{C2} - (F_{C2} - F_{C1}) \left( \frac{r_2 - r}{r_2 - r_1} \right)$$

**Example 18.13.** A Hartnell governor having a central sleeve spring and two right-angled bell crank levers moves between 290 r.p.m. and 310 r.p.m. for a sleeve lift of 15 mm. The sleeve arms and the ball arms are 80 mm and 120 mm respectively. The levers are pivoted at 120 mm from the governor axis and mass of each ball is 2.5 kg. The ball arms are parallel to the governor axis at the lowest equilibrium speed. Determine : **1.** loads on the spring at the lowest and the highest equilibrium speeds, and **2.** stiffness of the spring.

**Solution.** Given :  $N_1 = 290$  r.p.m. or  $\omega_1 = 2\pi \times 290/60 = 30.4$  rad/s ;  $N_2 = 310$  r.p.m. or  $\omega_2 = 2\pi \times 310/60 = 32.5$  rad/s ;  $h = 15$  mm = 0.015 m ;  $y = 80$  mm = 0.08 m ;  $x = 120$  mm = 0.12 m ;  $r = 120$  mm = 0.12 m ;  $m = 2.5$  kg

**1. Loads on the spring at the lowest and highest equilibrium speeds**

Let  $S$  = Spring load at lowest equilibrium speed, and

$S_2$  = Spring load at highest equilibrium speed.

Since the ball arms are parallel to governor axis at the lowest equilibrium speed (*i.e.* at  $N_1 = 290$  r.p.m.), as shown in Fig. 18.20 (a), therefore

$$r = r_1 = 120 \text{ mm} = 0.12 \text{ m}$$

We know that centrifugal force at the minimum speed,

$$F_{C1} = m (\omega_1)^2 r_1 = 2.5 (30.4)^2 \cdot 0.12 = 277 \text{ N}$$

Now let us find the radius of rotation at the highest equilibrium speed, *i.e.* at  $N_2 = 310$  r.p.m. The position of ball arm and sleeve arm at the highest equilibrium speed is shown in Fig. 18.20 (b).

Let  $r_2 =$  Radius of rotation at  $N_2 = 310$  r.p.m.

We know that  $h = (r_2 - r_1) \frac{y}{x}$

or 
$$r_2 = r_1 + h \left( \frac{x}{y} \right) = 0.12 + 0.015 \left( \frac{0.12}{0.08} \right) = 0.1425 \text{ m}$$

$\therefore$  Centrifugal force at the maximum speed,

$$F_{C2} = m (\omega_2)^2 r_2 = 2.5 \times (32.5)^2 \times 0.1425 = 376 \text{ N}$$

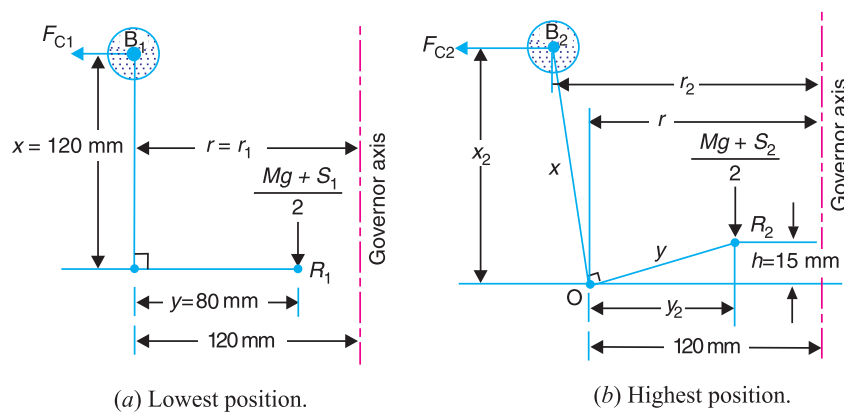

Fig. 18.20

Neglecting the obliquity effect of arms and the moment due to the weight of the balls, we have for lowest position,

$$M \cdot g + S_1 = 2F_{C1} \times \frac{x}{y} = 2 \times 277 \times \frac{0.12}{0.08} = 831 \text{ N}$$

$\therefore S_2 = 831 \text{ N Ans.}$  ( $\because M = 0$ )

and for highest position,

$$M \cdot g + S_2 = 2F_{C2} \times \frac{x}{y} = 2 \times 376 \times \frac{0.12}{0.08} = 1128 \text{ N}$$

$\therefore S_1 = 1128 \text{ N Ans.}$  ( $\because M = 0$ )

### 2. Stiffness of the spring

We know that stiffness of the spring,

$$s = \frac{S_2 - S_1}{h} = \frac{1128 - 831}{15} = 19.8 \text{ N/mm Ans.}$$

**Example 18.14.** In a spring loaded Hartnell type governor, the extreme radii of rotation of the balls are 80 mm and 120 mm. The ball arm and the sleeve arm of the bell crank lever are equal in length. The mass of each ball is 2 kg. If the speeds at the two extreme positions are 400 and 420 r.p.m., find : 1. the initial compression of the central spring, and 2. the spring constant.

## 682 • Theory of Machines

**Solution.** Given :  $r_1 = 80 \text{ mm} = 0.08 \text{ m}$  ;  $r_2 = 120 \text{ mm} = 0.12 \text{ m}$  ;  $x = y$  ;  $m = 2 \text{ kg}$  ;  $N_1 = 400$  r.p.m. or  $\omega = 2\pi \times 400/60 = 41.9 \text{ rad/s}$  ;  $N_2 = 420$  r.p.m. or  $\omega_2 = 2\pi \times 420/60 = 44 \text{ rad/s}$

### Initial compression of the central spring

We know that the centrifugal force at the minimum speed,

$$F_{C1} = m (\omega_1)^2 r_1 = 2 (41.9)^2 0.08 = 281 \text{ N}$$

and centrifugal force at the maximum speed,

$$F_{C2} = m (\omega_2)^2 r_2 = 2 (44)^2 0.12 = 465 \text{ N}$$

Let  $S_1 =$  Spring force at the minimum speed, and  
 $S_2 =$  Spring force at the maximum speed.

We know that for minimum position,

$$M \cdot g + S_1 = 2 F_{C1} \times \frac{x}{y}$$

$$\therefore S_1 = 2 F_{C1} = 2 \times 281 = 562 \text{ N} \quad \dots (\because M = 0 \text{ and } x = y)$$

Similarly for maximum position,

$$M \cdot g + S_2 = 2 F_{C2} \times \frac{x}{y}$$

$$\therefore S_2 = 2 F_{C2} = 2 \times 465 = 930 \text{ N}$$

We know that lift of the sleeve,

$$h = (r_2 - r_1) \frac{y}{x} = r_2 - r_1 = 120 - 80 = 40 \text{ mm} \quad \dots (\because x = y)$$

$\therefore$  Stiffness of the spring,

$$s = \frac{S_2 - S_1}{h} = \frac{930 - 562}{40} = 9.2 \text{ N/mm}$$

We know that initial compression of the central spring

$$= \frac{S_1}{s} = \frac{562}{9.2} = 61 \text{ mm} \quad \text{Ans.}$$

### 2. Spring constant

We have calculated above that the spring constant or stiffness of the spring,

$$s = 9.2 \text{ N/mm} \quad \text{Ans.}$$

**Example 18.15.** A spring loaded governor of the Hartnell type has arms of equal length. The masses rotate in a circle of 130 mm diameter when the sleeve is in the mid position and the ball arms are vertical. The equilibrium speed for this position is 450 r.p.m., neglecting friction. The maximum sleeve movement is to be 25 mm and the maximum variation of speed taking in account the friction to be 5 per cent of the mid position speed. The mass of the sleeve is 4 kg and the friction may be considered equivalent to 30 N at the sleeve. The power of the governor must be sufficient to overcome the friction by one per cent change of speed either way at mid-position. Determine, neglecting obliquity effect of arms ; **1.** The value of each rotating mass ; **2.** The spring stiffness in N/mm ; and **3.** The initial compression of spring.

**Solution.** Given :  $x = y$  ;  $d = 130 \text{ mm}$  or  $r = 65 \text{ mm} = 0.065 \text{ m}$  ;  $N = 450$  r.p.m. or  $\omega = 2\pi \times 450/60 = 47.23 \text{ rad/s}$  ;  $h = 25 \text{ mm} = 0.025 \text{ m}$  ;  $M = 4 \text{ kg}$  ;  $F = 30 \text{ N}$

#### 1. Value of each rotating mass

Let  $m =$  Value of each rotating mass in kg, and  
 $S =$  Spring force on the sleeve at mid position in newtons.

Since the change of speed at mid position to overcome friction is 1 per cent either way (*i.e.*  $\pm 1\%$ ), therefore

Minimum speed at mid position,

$$\omega = \omega - 0.01\omega = 0.99\omega = 0.99 \times 47.13 = 46.66 \text{ rad/s}$$

and maximum speed at mid-position,

$$\omega_2 = \omega + 0.01\omega = 1.01\omega = 1.01 \times 47.13 = 47.6 \text{ rad/s}$$

$\therefore$  Centrifugal force at the minimum speed,

$$F_{C1} = m (\omega_1)^2 r = m (46.66)^2 \cdot 0.065 = 141.5 \text{ m N}$$

and centrifugal force at the maximum speed,

$$F_{C2} = m (\omega_2)^2 r = m (47.6)^2 \cdot 0.065 = 147.3 \text{ m N}$$

We know that for minimum speed at mid-position,

$$S + (M \cdot g + F) = 2 F_{C1} \times \frac{x}{y}$$

or  $S + (4 \times 9.81 - 30) = 2 \times 141.5 \text{ m} \times 1$   
 $\dots (\because x=y)$

$\therefore S + 9.24 = 283 \text{ m} \dots (i)$

and for maximum speed at mid-position,

$$S + (M \cdot g + F) = 2 F_{C2} \times \frac{x}{y}$$

$S + (4 \times 9.81 + 30) = 2 \times 147.3 \text{ m} \times 1$   
 $\dots (\because x=y)$

$\therefore S + 69.24 = 294.6 \text{ m} \dots (ii)$

From equations (i) and (ii),

$$m = 5.2 \text{ kg Ans.}$$

## 2. Spring stiffness in N/mm

Let  $s$  = Spring stiffness in N/mm.

Since the maximum variation of speed, considering friction is  $\pm 5\%$  of the mid-position speed, therefore,

Minimum speed considering friction,

$$\omega_1' = \omega - 0.05\omega = 0.95\omega = 0.95 \times 47.13 = 44.8 \text{ rad/s}$$

and maximum speed considering friction,

$$\omega_2' = \omega + 0.05\omega = 1.05\omega = 1.05 \times 47.13 = 49.5 \text{ rad/s}$$

We know that minimum radius of rotation considering friction,

$$r_1 = r - h_1 \times \frac{x}{y} = 0.065 - \frac{0.025}{2} = 0.0525 \text{ m}$$

$$\dots \left( \because x = y, \text{ and } h_1 = \frac{h}{2} \right)$$

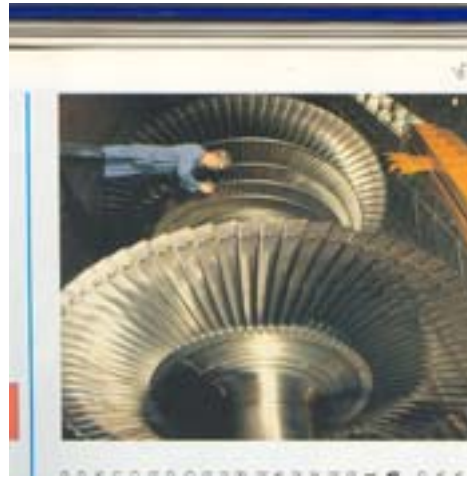

A steam turbine used in thermal power stations.

Note : This picture is given as additional information and is not a direct example of the current chapter.

**684 • Theory of Machines**

and maximum radius of rotation considering friction,

$$r_2 = r + h_2 \times \frac{x}{y} = 0.065 + \frac{0.025}{2} = 0.0775 \text{ m}$$

...  $\left( \because x = y, \text{ and } h_2 = \frac{h}{2} \right)$

$\therefore$  Centrifugal force at the minimum speed considering friction,

$$F_{C1}' = m (\omega_1')^2 r_1 = 5.2 (44.8)^2 \cdot 0.0525 = 548 \text{ N}$$

and centrifugal force at the maximum speed considering friction,

$$F_{C2}' = m (\omega_2')^2 r_2 = 5.2 (49.5)^2 \cdot 0.0775 = 987 \text{ N}$$

Let  $S_1$  = Spring force at minimum speed considering friction, and  
 $S_2$  = Spring force at maximum speed considering friction.

We know that for minimum speed considering friction,

$$S_1 + (M \cdot g - F) = 2 F_{C1}' \times \frac{x}{y}$$

$$S_1 + (4 \times 9.81 - 30) = 2 \times 548 \times 1 \quad \dots (\because x = y)$$

$$\therefore S_1 + 9.24 = 1096 \quad \text{or} \quad S_1 = 1096 - 9.24 = 1086.76 \text{ N}$$

and for maximum speed considering friction,

$$S_2 + (M \cdot g + F) = 2 F_{C2}' \times \frac{x}{y}$$

$$S_2 + (4 \times 9.81 + 30) = 2 \times 987 \times 1 \quad \dots (\because x = y)$$

$$\therefore S_2 + 69.24 = 1974 \quad \text{or} \quad S_2 = 1974 - 69.24 = 1904.76 \text{ N}$$

We know that stiffness of the spring,

$$s = \frac{S_2 - S_1}{h} = \frac{1904.76 - 1086.76}{25} = 32.72 \text{ N/mm Ans.}$$

**3. Initial compression of the spring**

We know that initial compression of the spring

$$= \frac{S_1}{s} = \frac{1086.76}{32.72} = 33.2 \text{ mm Ans.}$$

**Example 18.16.** In a spring loaded governor of the Hartnell type, the mass of each ball is 1 kg, length of vertical arm of the bell crank lever is 100 mm and that of the horizontal arm is 50 mm. The distance of fulcrum of each bell crank lever is 80 mm from the axis of rotation of the governor. The extreme radii of rotation of the balls are 75 mm and 112.5 mm. The maximum equilibrium speed is 5 per cent greater than the minimum equilibrium speed which is 360 r.p.m. Find, neglecting obliquity of arms, initial compression of the spring and equilibrium speed corresponding to the radius of rotation of 100 mm.

**Solution.** Given :  $m = 1 \text{ kg}$  ;  $x = 100 \text{ mm} = 0.1 \text{ m}$  ;  $y = 50 \text{ mm} = 0.05 \text{ m}$  ;  $r = 80 \text{ mm} = 0.08 \text{ m}$  ;  $r_1 = 75 \text{ mm} = 0.075 \text{ m}$  ;  $r_2 = 112.5 \text{ mm} = 0.1125 \text{ m}$  ;  $N_1 = 360 \text{ r.p.m.}$  or  $\omega_1 = 2 \pi \times 360/60 = 37.7 \text{ rad/s}$

Since the maximum equilibrium speed is 5% greater than the minimum equilibrium speed ( $\omega_1$ ), therefore maximum equilibrium speed,

$$\omega_2 = 1.05 \times 37.7 = 39.6 \text{ rad/s}$$

We know that centrifugal force at the minimum equilibrium speed,

$$F_{C1} = m (\omega_1)^2 r_1 = 1 (37.7)^2 \cdot 0.075 = 106.6 \text{ N}$$



and centrifugal force at the maximum equilibrium speed,

$$F_{C2} = m (\omega_2)^2 r_2 = 1 (39.6)^2 0.1125 = 176.4 \text{ N}$$

**Initial compression of the spring**

Let  $S_1$  = Spring force corresponding to  $\omega_1$ , and  
 $S_2$  = Spring force corresponding to  $\omega_2$ .

Since the obliquity of arms is neglected, therefore for minimum equilibrium position,

$$M \cdot g + S_1 = 2 F_{C1} \times \frac{x}{y} = 2 \times 106.6 \times \frac{0.1}{0.05} = 426.4 \text{ N}$$

$$\therefore S_1 = 426.4 \text{ N} \quad \dots(\because M = 0)$$

and for maximum equilibrium position,

$$M \cdot g + S_2 = 2 F_{C2} \times \frac{x}{y} = 2 \times 176.4 \times \frac{0.1}{0.05} = 705.6 \text{ N}$$

$$\therefore S_2 = 705.6 \text{ N} \quad \dots(\because M = 0)$$

We know that lift of the sleeve,

$$h = (r_2 - r_1) \frac{y}{x} = (0.1125 - 0.075) \frac{0.05}{0.1} = 0.01875 \text{ m}$$

$$\text{and stiffness of the spring } s = \frac{S_2 - S_1}{h} = \frac{705.6 - 426.4}{0.01875} = 14890 \text{ N/m} = 14.89 \text{ N/mm}$$

$\therefore$  Initial compression of the spring

$$= \frac{S_1}{s} = \frac{426.4}{14.89} = 28.6 \text{ mm} \quad \text{Ans.}$$

**Equilibrium speed corresponding to radius of rotation  $r = 100 \text{ mm} = 0.1 \text{ m}$**

Let  $N$  = Equilibrium speed in r.p.m.

Since the obliquity of the arms is neglected, therefore the centrifugal force at any instant,

$$F_C = F_{C1} + (F_{C2} - F_{C1}) \left( \frac{r - r_1}{r_2 - r_1} \right)$$

$$= 106.6 + (176.4 - 106.6) \left( \frac{0.1 - 0.075}{0.1125 - 0.075} \right) = 153 \text{ N}$$

We know that centrifugal force ( $F_C$ ),

$$153 = m \cdot \omega^2 \cdot r = 1 \left( \frac{2\pi N}{60} \right)^2 0.1 = 0.0011 N^2$$

$$\therefore N^2 = 153 / 0.0011 = 139090 \quad \text{or} \quad N = 373 \text{ r.p.m.} \quad \text{Ans.}$$

**Example 18.17.** In a spring loaded governor of the Hartnell type, the mass of each ball is 5 kg and the lift of the sleeve is 50 mm. The speed at which the governor begins to float is 240 r.p.m., and at this speed the radius of the ball path is 110 mm. The mean working speed of the governor is 20 times the range of speed when friction is neglected. If the lengths of ball and roller arm of the bell crank lever are 120 mm and 100 mm respectively and if the distance between the centre of pivot of bell crank lever and axis of governor spindle is 140 mm, determine the initial compression of the spring taking into account the obliquity of arms.

If friction is equivalent to a force of 30 N at the sleeve, find the total alteration in speed before the sleeve begins to move from mid-position.

686 • Theory of Machines

**Solution.** Given :  $m = 5 \text{ kg}$  ;  $h = 50 \text{ mm} = 0.05 \text{ m}$  ;  $N_1 = 240 \text{ r.p.m.}$  or  $\omega_1 = 2 \pi \times 240/60 = 25.14 \text{ rad/s}$  ;  $r_1 = 110 \text{ mm} = 0.11 \text{ m}$  ;  $x = 120 \text{ mm} = 0.12 \text{ m}$  ;  $y = 100 \text{ mm} = 0.1 \text{ m}$  ;  $r = 140 \text{ mm} = 0.14 \text{ m}$  ;  $F = 30 \text{ N}$

**Initial compression of the spring taking into account the obliquity of arms**

First of all, let us find out the maximum speed of rotation ( $\omega_2$ ) in rad/s.

We know that mean working speed,

$$\omega = \frac{\omega_1 + \omega_2}{2}$$

and range of speed, neglecting friction

$$= \omega_2 - \omega_1$$

Since the mean working speed is 20 times the range of speed, therefore

$$\omega = 20 (\omega_2 - \omega_1)$$

or 
$$\frac{\omega_1 + \omega_2}{2} = 20 (\omega_2 - \omega_1)$$

$$25.14 + \omega_2 = 40 (\omega_2 - 25.14) = 40 \omega_2 - 1005.6$$

$$\therefore 40 \omega_2 - \omega_2 = 25.14 + 1005.6 = 1030.74 \quad \text{or} \quad \omega_2 = 26.43 \text{ rad/s}$$

The minimum and maximum position of the governor balls is shown in Fig. 18.21 (a) and (b) respectively.

Let  $r_2 =$  Maximum radius of rotation.

We know that lift of the sleeve,

$$h = (r_2 - r_1) \frac{y}{x}$$

or 
$$r_2 = r_1 + h \times \frac{x}{y} = 0.11 + 0.05 \times \frac{0.12}{0.1} = 0.17 \text{ m}$$

We know that centrifugal force at the minimum speed,

$$F_{C1} = m (\omega_1)^2 r_1 = 5 (25.14)^2 0.11 = 347.6 \text{ N}$$

and centrifugal force at the maximum speed,

$$F_{C2} = m (\omega_2)^2 r_2 = 5 (26.43)^2 0.17 = 593.8 \text{ N}$$

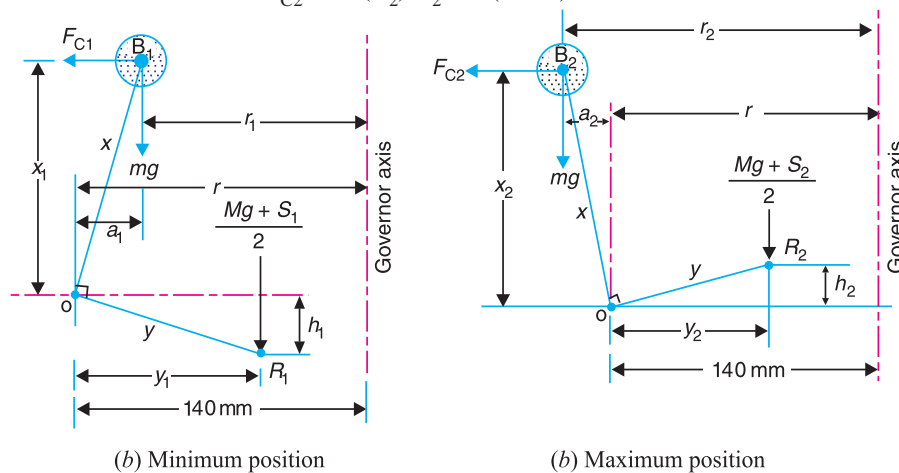

Fig. 18.21

Since the obliquity of arms is to be taken into account, therefore from the minimum position as shown in Fig. 18.21 (a),

$$a_1 = r - r_1 = 0.14 - 0.11 = 0.03 \text{ m}$$

$$x_1 = \sqrt{x^2 - (a_1)^2} = \sqrt{(0.12)^2 - (0.03)^2} = 0.1162 \text{ m}$$

and

$$y_1 = \sqrt{y^2 - (h_1)^2} = \sqrt{(0.1)^2 - (0.025)^2} = 0.0986 \text{ m}$$

... ( $\because h_1 = h/2 = 0.025 \text{ m}$ )

Similarly, for the maximum position, as shown in Fig. 18.21 (b),

$$a_2 = r_2 - r = 0.17 - 0.14 = 0.03 \text{ m}$$

$$\therefore x_2 = x_1 = 0.1162 \text{ m} \quad \dots (\because a_2 = a_1)$$

and

$$y_2 = y_1 = 0.0986 \text{ m} \quad \dots (\because h_2 = h_1)$$

Now taking moments about point  $O$  for the minimum position as shown in Fig. 18.21 (a),

$$\frac{M \cdot g + S_1}{2} \times y_1 = F_{C1} \times x_1 - m \cdot g \times a_1$$

$$\frac{S_1}{2} \times 0.0968 = 347.6 \times 0.1162 - 5 \times 9.81 \times 0.03 = 38.9 \text{ N} \quad \dots (\because M = 0)$$

$$\therefore S_1 = 2 \times 38.9/0.0968 = 804 \text{ N}$$

Similarly, taking moments about point  $O$  for the maximum position as shown in Fig. 18.21 (b),

$$\frac{M \cdot g + S_2}{2} \times y_2 = F_{C2} \times x_2 + m \cdot g \times a_2$$

$$\frac{S_2}{2} \times 0.0968 = 593.8 \times 0.1162 + 5 \times 9.81 \times 0.03 = 70.47 \text{ N} \quad \dots (\because M = 0)$$

$$\therefore S_2 = 2 \times 70.47/0.0968 = 1456 \text{ N}$$

We know that stiffness of the spring

$$s = \frac{S_2 - S_1}{h} = \frac{1456 - 804}{50} = 13.04 \text{ N/mm}$$

$\therefore$  Initial compression of the spring

$$= \frac{S_1}{s} = \frac{804}{13.04} = 61.66 \text{ mm} \quad \text{Ans.}$$

### Total alternation in speed when friction is taken into account

We know that spring force for the mid-position,

$$S = S_1 + h_1 \cdot s = 8.4 + 25 \times 13.04 = 1130 \text{ N} \quad \dots (\because h_1 = h/2 = 25 \text{ mm})$$

and mean angular speed, 
$$\omega = \frac{\omega_1 + \omega_2}{2} = \frac{25.14 + 26.43}{2} = 25.785 \text{ rad/s}$$

or 
$$N = \omega \times 60 / 2\pi = 25.785 \times 60 / 2\pi = 246.2 \text{ r.p.m.}$$

$\therefore$  Speed when the sleeve begins to move downwards from the mid-position,

$$N' = N \sqrt{\frac{S - F}{S}} = 246.2 \sqrt{\frac{1130 - 30}{1130}} = 243 \text{ r.p.m.}$$

and speed when the sleeve begins to move upwards from the mid-position,

$$N'' = N \sqrt{\frac{S + F}{S}} = 246.2 \sqrt{\frac{1130 + 30}{1130}} = 249 \text{ r.p.m.}$$

$\therefore$  Alteration in speed  $= N'' - N' = 249 - 243 = 6 \text{ r.p.m.} \quad \text{Ans.}$

**Example 18.18.** Fig. 18.22 shows diagrammatically a centrifugal governor. The masses 'm' are directly connected to one another by two parallel and identical close coiled springs, one on either side. In the position shown, with the mass arms parallel to the axis of rotation, the equilibrium speed is 900 r.p.m. Given ball circle radius = 70 mm ; length of ball arm = 85 mm and length of sleeve arm = 50 mm.

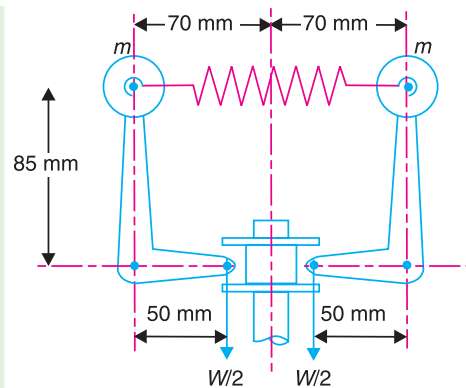

Fig. 18.22.

1. When the speed is increased by 1% without any change of radius for the given position, an axial force of 30 N is required at the sleeve to maintain equilibrium. Determine the mass of each ball.

2. Find the stiffness and initial extension of each spring, if the rate of sleeve movement, when in mid position is 20 mm for 480 r.p.m. change of speed.

**Solution.** Given :  $N = 900$  r.p.m. or  $\omega = 2\pi \times 900/60 = 94.26$  rad/s ;  $r = 70$  mm = 0.07 m ;  $x = 85$  mm = 0.085 m ;  $y = 50$  mm = 0.05 m ;  $W = 30$  N

**1. Mass of each ball**

Let  $m =$  Mass of each ball in kg.

We know that centrifugal force at the equilibrium speed,

$$F_C = m \cdot \omega^2 \cdot r = m (94.26)^2 \cdot 0.07 = 622 \text{ mN}$$

Since the speed is increased by 1% without any change of radius, therefore increased speed,

$$\omega_1 = \omega + 0.01 \omega = 1.01 \omega = 1.01 \times 94.26 = 95.2 \text{ rad/s}$$

and centrifugal force at the increased speed,

$$F_{C1} = m (\omega_1)^2 r = m (95.2)^2 \cdot 0.07 = 634.4 \text{ mN}$$

Now taking moments about point O as shown in Fig. 18.23, we get

$$(F_{C1} - F_C) \cdot 0.085 = \frac{W}{2} \times 0.05$$

$$(634.4 \text{ m} - 622 \text{ m}) \cdot 0.085 = \frac{30}{2} \times 0.05 = 0.75$$

$$1.054 \text{ m} = 0.75$$

or  $m = 0.75/1.054 = 0.7$  kg **Ans.**

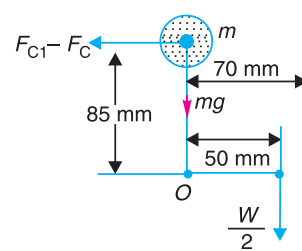

Fig. 18.23

**2. Stiffness and initial extension of each spring**

Let  $s =$  Stiffness of each spring.

We know that centrifugal force at the equilibrium speed, i.e. at 900 r.p.m.

$$F_C = 622 \text{ m} = 622 \times 0.7 = 435.4 \text{ N}$$

Since the change of speed is 480 r.p.m., therefore increased speed,

$$N_2 = 900 + 480 = 1380 \text{ r.p.m.}$$

∴ Angular increased speed,

$$\omega_2 = 2\pi \times 1380/60 = 144.5 \text{ rad/s}$$

Also, it is given that for 480 r.p.m. change of speed, the rate of sleeve movement is 20 mm, *i.e.*

$$h = 20 \text{ mm} = 0.02 \text{ m}$$

Let  $r =$  Radius of rotation at 900 r.p.m. = 0.07 m . . . (Given)

$$r_2 = \text{Radius of rotation at 1380 r.p.m.}$$

We know that for the radius of rotation to change from  $r$  to  $r_2$ , the increase in length of radius of rotation is

$$r_2 - r = h \times \frac{x}{y} = 0.02 \times \frac{0.085}{0.05} = 0.034 \text{ m}$$

$$\therefore r_2 = r + 0.034 = 0.07 + 0.034 = 0.104 \text{ m}$$

and centrifugal force at the increased speed ( $\omega_2$ ),

$$F_{C2} = m (\omega_2)^2 r_2 = 0.7 (144.5)^2 0.104 = 1520 \text{ N}$$

$\therefore$  Stiffness of each spring,

$$s = \frac{\text{Increase in force for one ball}}{\text{Increase in length for each spring}} = \frac{F_{C2} - F_C}{2(r_2 - r)} = \frac{1520 - 435.4}{2(0.104 - 0.07)} \\ = 15\,950 \text{ N/m} = 15.95 \text{ N/mm} \text{ Ans.}$$

and initial extension of each spring

$$= \frac{F_C}{s} = \frac{435.4}{15.95} = 27.3 \text{ mm} \text{ Ans.}$$

**Example 18.19.** In a spring controlled governor of the type, as shown in Fig. 18.24, the mass of each ball is 1.5 kg and the mass of the sleeve is 8 kg. The two arms of the bell crank lever are at right angles and their lengths are  $OB = 100 \text{ mm}$  and  $OA = 40 \text{ mm}$ . The distance of the fulcrum  $O$  of each bell crank lever from the axis of rotation is 50 mm and minimum radius of rotation of the governor balls is also 50 mm. The corresponding equilibrium speed is 240 r.p.m. and the sleeve is required to lift 10 mm for an increase in speed of 5 per cent. Find the stiffness and initial compression of the spring.

**Solution.** Given :  $m = 1.5 \text{ kg}$  ;  $M = 8 \text{ kg}$  ;  $OB = x = 100 \text{ mm} = 0.1 \text{ m}$  ;  $OA = y = 40 \text{ mm} = 0.04 \text{ m}$  ;  $r = 50 \text{ mm} = 0.05 \text{ m}$  ;  $r_1 = 50 \text{ mm} = 0.05 \text{ m}$  ;  $N_1 = 240 \text{ r.p.m.}$  or  $\omega_1 = 2\pi \times 240/60 = 25.14 \text{ rad/s}$  ;  $h = 10 \text{ mm} = 0.01 \text{ m}$  ; Increase in speed = 5%

#### Stiffness of the spring

The spring controlled governor of the type, as shown in Fig. 18.24, has the pivots for the bell crank lever on the moving sleeve. The spring is compressed between the sleeve and the cap which is fixed to the end of the governor shaft. The simplest way of analysing this type of governor is by taking moments about the instantaneous centre of all the forces which act on one of the bell crank levers.

The minimum position of the governor is shown in Fig. 18.25 (a).

We know that the centrifugal force acting on the ball at the minimum equilibrium speed,

$$F_{C1} = m (\omega_1)^2 r_1 = 1.5 (25.14)^2 0.05 = 47.4 \text{ N}$$

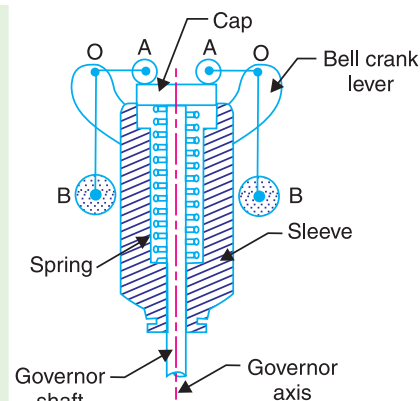

Fig. 18.24

690 • Theory of Machines

Let  $S_1$  = Spring force at the minimum equilibrium speed.

The instantaneous centre  $I$  for the bell crank lever coincides with the roller centre  $A$ . Taking moments about  $A$ ,

$$F_{C1} \times x = \left( m \cdot g + \frac{M \cdot g + S_1}{2} \right) OA$$

$$47.4 \times 0.1 = \left( 1.5 \times 9.81 + \frac{8 \times 9.81 + S_1}{2} \right) 0.04 = 0.6 + 1.57 + 0.02 S_1$$

$$4.74 = 2.17 + 0.02 S_1 \quad \text{or} \quad S_1 = \frac{4.74 - 2.17}{0.02} = 128.5 \text{ N}$$

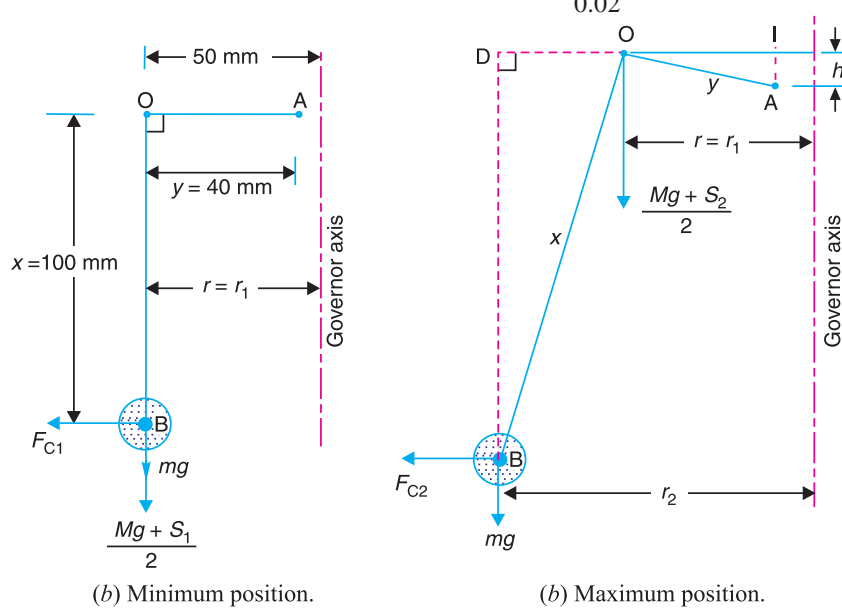

Fig. 18.25

The maximum position of the governor is shown in Fig. 18.25 (b). From the geometry of the figure,

$$\frac{r_2 - r_1}{x} = \frac{h}{y} \quad \text{or} \quad r_2 = r_1 + h \times \frac{x}{y} = 0.05 + 0.01 \times \frac{0.1}{0.04} = 0.075 \text{ m}$$

Since the increase in speed is 5%, therefore the maximum equilibrium speed of rotation,

$$N_2 = N_1 + 0.05 N_1 = 1.05 N_1 = 1.05 \times 240 = 252 \text{ r.p.m.}$$

or

$$\omega_2 = 2 \pi \times 252/60 = 26.4 \text{ rad/s}$$

∴ Centrifugal force acting on the ball at the maximum equilibrium speed,

$$F_{C2} = m (\omega_2)^2 r_2 = 1.5 (26.4)^2 0.075 = 78.4 \text{ N}$$

Let  $S_2$  = Spring force at the maximum equilibrium speed.

The instantaneous centre in this case lies at  $I$  as shown in Fig. 18.25 (b). From the geometry of the figure,

$$OI = \sqrt{(OA)^2 - (IA)^2} = \sqrt{y^2 - h^2} = \sqrt{(0.04)^2 - (0.01)^2} = 0.0387 \text{ m}$$

$$BD = \sqrt{(OB)^2 - (OD)^2} = \sqrt{x^2 - (r_2 - r_1)^2}$$

$$= \sqrt{(0.1)^2 - (0.075 - 0.05)^2} = 0.097 \text{ m}$$

$$ID = OI + OD = 0.0387 + (0.075 - 0.05) = 0.0637 \text{ m}$$

Now taking moments about  $I$ ,

$$F_{C2} \times BD = m \cdot g \times ID + \frac{M \cdot g + S_2}{2} \times OI$$

$$78.4 \times 0.097 = 1.5 \times 9.81 \times 0.0637 + \left( \frac{8 \times 9.81 + S_2}{2} \right) 0.0387$$

$$7.6 = 0.937 + 1.52 + 0.02 S_2 = 2.457 + 0.019 S_2$$

$$\therefore S_2 = \frac{7.6 - 2.457}{0.019} = 270.7 \text{ N}$$

We know that stiffness of the spring,

$$s = \frac{S_2 - S_1}{h} = \frac{270.7 - 128.5}{10} = 14.22 \text{ N/mm Ans.}$$

#### Initial compression of the spring

We know that initial compression of the spring

$$= \frac{S_1}{s} = \frac{128.5}{14.22} = 9.04 \text{ mm Ans.}$$



An overview of a thermal power station.

Note : This picture is given as additional information and is not a direct example of the current chapter.

### 18.9. Hartung Governor

A spring controlled governor of the Hartung type is shown in Fig. 18.26 (a). In this type of governor, the vertical arms of the bell crank levers are fitted with spring balls which compress against the frame of the governor when the rollers at the horizontal arm press against the sleeve.

Let  $S$  = Spring force,  
 $F_C$  = Centrifugal force,  
 $M$  = Mass on the sleeve, and  
 $x$  and  $y$  = Lengths of the vertical and horizontal arm of the bell crank lever respectively.

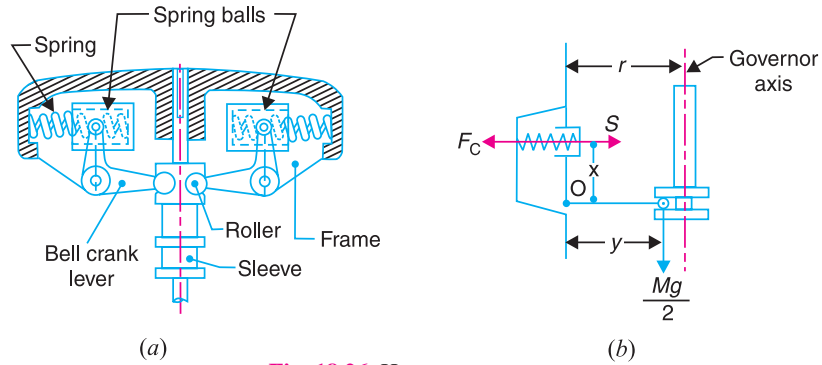

Fig. 18.26. Hartung governor.

Fig. 18.26 (a) and (b) show the governor in mid-position. Neglecting the effect of obliquity of the arms, taking moments about the fulcrum  $O$ ,

$$F_C \times x = S \times x + \frac{M \cdot g}{2} \times y$$

**Example 18.20.** In a spring-controlled governor of the Hartung type, the length of the ball and sleeve arms are 80 mm and 120 mm respectively. The total travel of the sleeve is 25 mm. In the mid position, each spring is compressed by 50 mm and the radius of rotation of the mass centres is 140 mm. Each ball has a mass of 4 kg and the spring has a stiffness of 10 kN/m of compression. The equivalent mass of the governor gear at the sleeve is 16 kg. Neglecting the moment due to the revolving masses when the arms are inclined, determine the ratio of the range of speed to the mean speed of the governor. Find, also, the speed in the mid-position.

**Solution.** Given :  $x = 80 \text{ mm} = 0.08 \text{ m}$  ;  $y = 120 \text{ mm} = 0.12 \text{ m}$  ;  $h = 25 \text{ mm} = 0.025 \text{ m}$  ;  $r = 140 \text{ mm} = 0.14 \text{ m}$  ;  $m = 4 \text{ kg}$  ;  $s = 10 \text{ kN/m} = 10 \times 10^3 \text{ N/m}$  ;  $M = 16 \text{ kg}$  ; Initial compression =  $50 \text{ mm} = 0.05 \text{ m}$

**Mean speed of the governor**

First of all, let us find the mean speed of the governor *i.e.* the speed when the governor is in mid-position as shown in Fig. 18.27 (a).

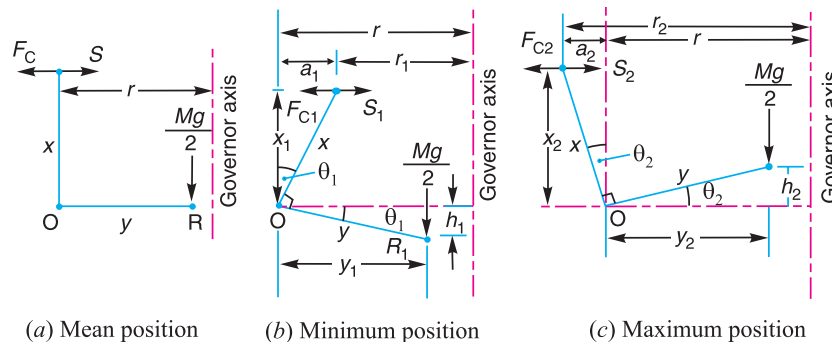

Fig. 18.27



Let  $\omega$  = Mean angular speed in rad/s, and  
 $N$  = Mean speed in r.p.m.

We know that the centrifugal force acting on the ball spring,

$$F_C = m \cdot \omega^2 \cdot r = 4 \times \omega^2 \times 0.14 = 0.56 \omega^2 \text{ N}$$

and Spring force,  $S$  = Stiffness  $\times$  Initial compression =  $10 \times 10^3 \times 0.05 = 500 \text{ N}$

Now taking moments about point  $O$ , neglecting the moment due to the revolving masses, we have

$$F_C \times x = S \times x + \frac{M \cdot g}{2} \times y$$

$$0.56 \omega^2 \times 0.08 = 500 \times 0.08 + \frac{16 \times 9.81}{2} \times 0.12 = 40 + 9.42 = 49.42$$

$$\therefore \omega^2 = \frac{49.42}{0.56 \times 0.08} = 1103 \quad \text{or} \quad \omega = 33.2 \text{ rad/s}$$

$$\text{and} \quad N = \frac{33.23 \times 60}{2\pi} = 317 \text{ r.p.m. } \mathbf{Ans.}$$

#### Ratio of range of speed to mean speed

Let  $\omega_1$  = Minimum angular speed in rad/s, at the minimum radius of rotation  $r_1$ ,

$\omega_2$  = Maximum angular speed in rad/s, at the maximum radius of rotation  $r_2$ ,

$N_1$  and  $N_2$  = Corresponding minimum and maximum speeds in r.p.m.

The minimum and maximum position is shown in Fig. 18.27 (b) and (c) respectively. First of all, let us find the minimum speed  $N_1$ .

From the geometry of the Fig. 18.27 (b),

$$\frac{r - r_1}{h_1} = \frac{x}{y} \quad \text{or} \quad r_1 = r - h_1 \times \frac{x}{y} = 0.14 - \frac{0.025}{2} \times \frac{0.08}{0.12} = 0.132 \text{ m} \quad \dots (\because h_1 = h/2)$$

We know that centrifugal force at the minimum position,

$$F_{C1} = m (\omega_1)^2 r_1 = 4 (\omega_1)^2 0.132 = 0.528 (\omega_1)^2 \text{ N}$$

and spring force at the minimum position,

$$S_1 = [\text{Initial compression} - (r - r_1)] \times \text{Stiffness} \\ = [0.05 - (0.14 - 0.132)] 10 \times 10^3 = 420 \text{ N}$$

Now taking moments about the fulcrum  $O$ , neglecting the obliquity of arms (*i.e.* taking  $x_1 = x$  and  $y_1 = y$ ),

$$F_{C1} \times x = S_1 \times x + \frac{M \cdot g}{2} \times y$$

$$0.528 (\omega_1)^2 0.08 = 420 \times 0.08 + \frac{16 \times 9.81}{2} \times 0.12 = 33.6 + 9.42 = 43.02$$

$$\therefore (\omega_1)^2 = \frac{43.02}{0.528 \times 0.08} = 1019 \quad \text{or} \quad \omega_1 = 32 \text{ rad/s}$$

$$\text{and} \quad N_1 = \frac{32 \times 60}{2\pi} = 305.5 \text{ r.p.m.}$$

**694 • Theory of Machines**

Now let us find the maximum speed  $N_2$ . From the geometry of the Fig. 18.27 (c),

$$\frac{r_2 - r}{h_2} = \frac{x}{y} \quad \text{or} \quad r_2 = r + h_2 \times \frac{x}{y} = 0.14 + \frac{0.025}{2} \times \frac{0.08}{0.12} = 0.148 \text{ m}$$

... ( $\because h_2 = h/2$ )

We know that centrifugal force at the maximum position,

$$F_{C2} = m (\omega_2)^2 r_2 = 4 (\omega_2)^2 0.148 = 0.592 (\omega_2)^2 \text{ N}$$

and spring force at the maximum position,

$$S_2 = [\text{Initial compression} + (r_2 - r) \times \text{Stiffness}]$$

$$= [0.05 + (0.148 - 0.14)] \times 10 \times 10^3 = 580 \text{ N}$$

Now taking moments about the fulcrum  $O$ , neglecting obliquity of arms (*i.e.* taking  $x_2 = x$  and  $y_2 = y$ ),

$$F_{C2} \times x = S_2 \times x + \frac{M \cdot g}{2} \times y$$

$$0.592 (\omega_2)^2 0.08 = 580 \times 0.08 + \frac{16 \times 9.81}{2} \times 0.12 = 46.4 + 9.42 = 55.82$$

$$\therefore (\omega_2)^2 = \frac{55.82}{0.592 \times 0.08} = 1178 \quad \text{or} \quad \omega_2 = 34.32 \text{ rad/s}$$

and

$$N_2 = \frac{34.32 \times 60}{2\pi} = 327.7 \text{ r.p.m.}$$

We know that range of speed

$$= N_2 - N_1 = 327.7 - 305.5 = 22.2 \text{ r.p.m.}$$

$\therefore$  Ratio of range of speed to mean speed

$$= \frac{N_2 - N_1}{N} = \frac{22.2}{317} = 0.07 \quad \text{or} \quad 7\% \text{ Ans.}$$

**18.10. Wilson-Hartnell Governor**

A Wilson-Hartnell governor is a governor in which the balls are connected by a spring in tension as shown in Fig. 18.28. An auxiliary spring is attached to the sleeve mechanism through a lever by means of which the equilibrium speed for a given radius may be adjusted. The main spring may be considered of two equal parts each belonging to both the balls. The line diagram of a Wilson-Hartnell governor is shown in Fig. 18.29.

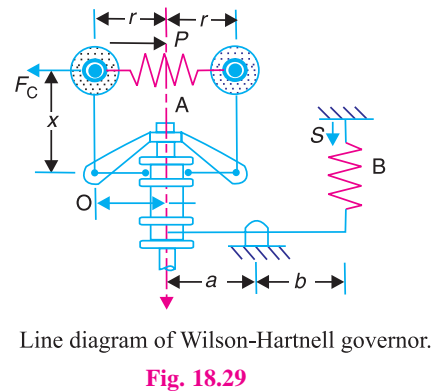
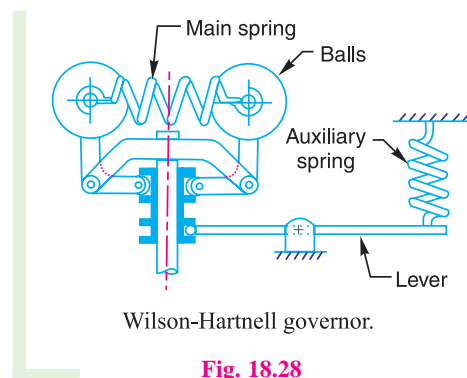

Let  $P$  = Tension in the main spring or ball spring  $A$ ,  
 $S$  = Tension in the auxiliary spring  $B$ ,  
 $m$  = Mass of each ball,  
 $M$  = Mass of sleeve,  
 $s_b$  = Stiffness of each ball spring,  
 $s_a$  = Stiffness of auxiliary spring,  
 $F_C$  = Centrifugal force of each ball, and  
 $r$  = Radius of rotation of balls,

Now total downward force on the sleeve

$$= M.g + S \times b/a$$

Taking moments about  $O$  and neglecting the effect of the pull of gravity on the ball,

$$(F_C - P) x = \frac{M.g + S \times b/a}{2} \times y$$

Let suffixes 1 and 2 be used to denote the values at minimum and maximum equilibrium speeds respectively.

∴ At minimum equilibrium speed,

$$(F_{C1} - P_1) x = \frac{M.g + S_1 \times b/a}{2} \times y \quad \dots (i)$$

and at maximum equilibrium speed,

$$(F_{C2} - P_2) x = \frac{M.g + S_2 \times b/a}{2} \times y \quad \dots (ii)$$

Subtracting equation (i) from equation (ii), we have

$$[(F_{C2} - F_{C1}) - (P_2 - P_1)] x = (S_2 - S_1) \frac{b}{a} \times \frac{y}{2} \quad \dots (iii)$$

When the radius increases from  $r_1$  to  $r_2$ , the ball springs extend by the amount  $2(r_2 - r_1)$  and the auxiliary spring extend by the amount  $(r_2 - r_1) \frac{y}{x} \times \frac{b}{a}$

$$\therefore P_2 - P_1 = 2 s_b \times 2 (r_2 - r_1) = 4 s_b (r_2 - r_1)$$

$$\text{and } S_2 - S_1 = s_a (r_2 - r_1) \frac{y}{x} \times \frac{b}{a}$$

Substituting the values of  $(P_2 - P_1)$  and  $(S_2 - S_1)$  in equation (iii),

$$[(F_{C2} - F_{C1}) - 4 s_b (r_2 - r_1)] x = s_a (r_2 - r_1) \frac{y}{x} \times \frac{b}{a} \times \frac{y}{2}$$

$$(F_{C2} - F_{C1}) - 4 s_b (r_2 - r_1) = \frac{s_a}{2} (r_2 - r_1) \left( \frac{y}{x} \times \frac{b}{a} \right)^2$$

$$\therefore 4 s_b + \frac{s_a}{2} \left( \frac{y}{x} \times \frac{b}{a} \right)^2 = \frac{F_{C2} - F_{C1}}{r_2 - r_1}$$

**Note :** When the auxiliary spring is not used, then  $s_a = 0$ .

$$\therefore 4 s_b = \frac{F_{C2} - F_{C1}}{r_2 - r_1} \quad \text{or} \quad s_b = \frac{F_{C2} - F_{C1}}{4 (r_2 - r_1)}$$

**Example 18.21.** The following particulars refer to a Wilson-Hartnell governor :

Mass of each ball = 2 kg ; minimum radius = 125 mm ; maximum radius = 175 mm ; minimum speed = 240 r.p.m. ; maximum speed = 250 r.p.m. ; length of the ball arm of each bell crank lever = 150 mm ; length of the sleeve arm of each bell crank lever = 100 mm ; combined stiffness of the two ball springs = 0.2 kN/m. Find the equivalent stiffness of the auxiliary spring referred to the sleeve.

**Solution.** Given :  $m = 2 \text{ kg}$  ;  $r_1 = 125 \text{ mm} = 0.125 \text{ m}$  ;  $r_2 = 175 \text{ mm} = 0.175 \text{ m}$  ;  $N_1 = 240 \text{ r.p.m.}$  or  $\omega_1 = 2 \pi \times 240/60 = 25.14 \text{ rad/s}$  ;  $N_2 = 250 \text{ r.p.m.}$  or  $\omega_2 = 2 \pi \times 250/60 = 26.2 \text{ rad/s}$  ;  $x = 150 \text{ mm} = 0.15 \text{ m}$  ;  $y = 100 \text{ mm} = 0.1 \text{ m}$  ;  $s_b = 0.2 \text{ kN/m} = 200 \text{ N/m}$

Let  $s =$  Equivalent stiffness of the auxiliary spring referred to the sleeve

$$= s_a \left( \frac{b}{a} \right)^2$$

We know that centrifugal force at the minimum speed,

$$F_{C1} = m (\omega_1)^2 r_1 = 2 (25.14)^2 0.125 = 158 \text{ N}$$

and centrifugal force at the maximum speed,

$$F_{C2} = m (\omega_2)^2 r_2 = 2 (26.2)^2 0.175 = 240 \text{ N}$$

We know that

$$4 s_b + \frac{s_a}{2} \left( \frac{y}{x} \times \frac{b}{a} \right)^2 = \frac{F_{C2} - F_{C1}}{r_2 - r_1}$$

$$4 \times 200 + \frac{s_b}{2} \left( \frac{0.1}{0.15} \times \frac{b}{a} \right)^2 = \frac{240 - 158}{0.175 - 0.125} = 1640$$

$$800 + 0.22 s_a \left( \frac{b}{a} \right)^2 = 1640 \quad \text{or} \quad 0.22 s_a \left( \frac{b}{a} \right)^2 = 1640 - 800 = 840$$

$$\therefore s_a \left( \frac{b}{a} \right)^2 = 800/0.22 = 3818 \text{ N/m} = 3.818 \text{ kN/m} \quad \text{Ans.}$$

**Example 18.22.** A spring loaded governor is shown in Fig. 18.30. The two balls, each of mass 6 kg, are connected across by two springs. An auxiliary spring B provides an additional force at the sleeve through the medium of a lever which pivots about a fixed centre at its left hand end. In the mean position, the radius of the governor balls is 120 mm and the speed is 600 r.p.m. The tension in each spring is then 1 kN. Find the tension in the spring B for this position.

When the sleeve moves up 15 mm, the speed is to be 630 r.p.m. Find the necessary stiffness of the spring B, if the stiffness of each spring A is 10 kN/m. Neglect the moment produced by the mass of the balls.

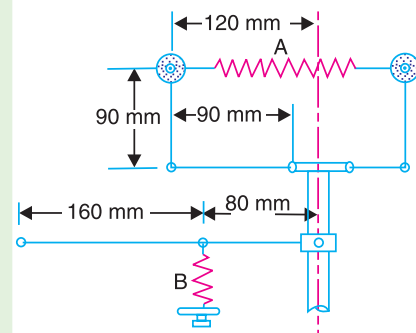

Fig. 18.30

**Solution.** Given :  $m = 6 \text{ kg}$  ;  $r = r_1 = 120 \text{ mm} = 0.12 \text{ m}$  ;  $N = N_1 = 600 \text{ r.p.m.}$  or  $\omega_1 = 2\pi \times 600/60 = 62.84 \text{ rad/s}$

**Tension in spring B**

Let  $S_{B1} =$  Spring force or tension in spring B, and

$M.g =$  Total load at the sleeve.

We know that centrifugal force at the minimum speed,

$$F_{C1} = m (\omega_1)^2 r_1 = 6 (62.84)^2 0.12 = 2843 \text{ N}$$

Since the tension in each spring A is 1 kN and there are two springs, therefore

Total spring force in spring A,

$$S_{A1} = 2 \times 1 = 2 \text{ kN} = 2000 \text{ N}$$

Taking moments about the pivot P (neglecting the moment produced by the mass of balls) in order to find the force  $Mg$  on the sleeve, in the mean position as shown in Fig. 18.31 (a),

$$F_{C1} \times 90 = S_{A1} \times 90 + \frac{M \cdot g}{2} \times 90 \quad \text{or} \quad F_{C1} = S_{A1} + \frac{M \cdot g}{2}$$

$$\therefore M \cdot g = 2 F_{C1} - 2 S_{A1} = 2 \times 2843 - 2 \times 2000 = 1686 \text{ N}$$

Now taking moments about point Q,

$$S_{B1} \times 160 = M \cdot g \cdot (80 + 160) = 1686 \times 240 = 404\,640$$

$$\therefore S_{B1} = 404\,640 / 160 = 2529 \text{ N} \quad \text{Ans.}$$

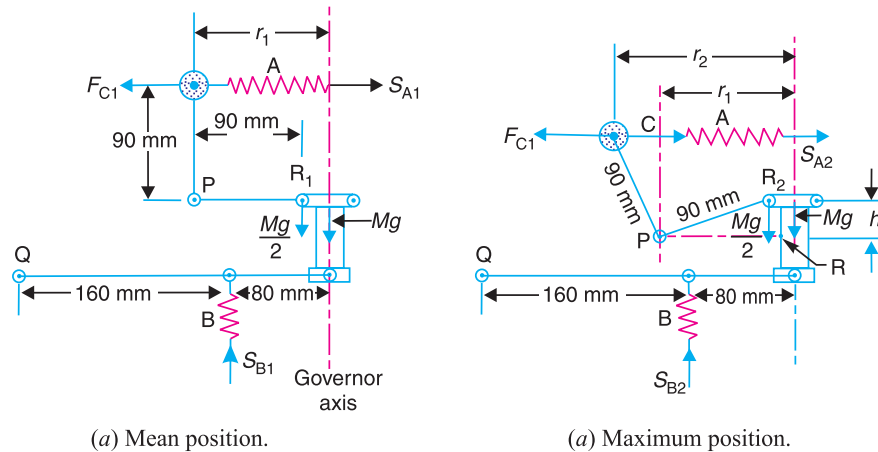

Fig. 18.31

**Stiffness of the spring B**

Given :  $h = 15 \text{ mm} = 0.015 \text{ m}$  ;  $N_2 = 630 \text{ r.p.m.}$  or  $\omega_2 = 2 \pi \times 630 / 60 = 66 \text{ rad/s}$ ;  
 $S_A = 10 \text{ kN/m} = 10 \times 10^3 \text{ N/m}$

Let  $s_B =$  Stiffness of spring B.

The maximum position is shown in Fig. 18.31 (b).

First of all, let us find the maximum radius of rotation ( $r_2$ ) when the sleeve moves up by 0.015 m. We know that

$$h = (r_2 - r_1) \frac{y}{x} \quad \text{or} \quad r_2 = r_1 + h \times \frac{x}{y} = 0.12 + 0.015 = 0.135 \text{ m}$$

... ( $\because x = y = 90 \text{ mm} = 0.09 \text{ m}$ )

$\therefore$  Centrifugal force at the maximum speed,

$$F_{C2} = m (\omega_2)^2 r_2 = 6 (66)^2 0.135 = 3528 \text{ N}$$

We know that extension of the spring A,

$$= 2 (r_2 - r_1) \times \text{No. of springs} = 2 (0.135 - 0.12) 2 = 0.06 \text{ m}$$

698 • Theory of Machines

∴ Total spring force in spring A,

$$S_{A2} = S_{A1} + \text{Extension of springs} \times \text{Stiffness of springs } (s_A) \\ = 2000 + 0.06 \times 10 \times 10^3 = 2600 \text{ N}$$

Now taking moments about  $P$ , neglecting the obliquity of arms,

$$F_{C2} \times 90 = S_{A2} \times 90 + \frac{M \cdot g}{2} \times 90 \quad \text{or} \quad F_{C2} = S_{A2} + \frac{M \cdot g}{2}$$

$$\therefore M \cdot g = 2 F_{C2} - 2 S_{A2} = 2 \times 3528 - 2 \times 2600 = 1856 \text{ N}$$

Again taking moments about point  $Q$  (neglecting the moment produced by the mass of balls) in order to find the spring force ( $S_{B2}$ ) when sleeve rises as shown in Fig. 18.31 (b),

$$S_{B2} \times 160 = M \cdot g (80 + 160) = 1856 \times 240 = 445\,440$$

$$\therefore S_{B2} = 445\,440 / 160 = 2784 \text{ N}$$

When the sleeve rises 0.015 m, the extension in spring  $B$

$$= 0.015 \left( \frac{160}{80 + 160} \right) = 0.01 \text{ m}$$

∴ Stiffness of spring  $B$ ,

$$s_B = \frac{S_{B2} - S_{B1}}{\text{Extension of spring } B} = \frac{2784 - 2529}{0.01} = 25\,500 \text{ N/m} \\ = 25.5 \text{ N/mm Ans.}$$

### 18.11. Pickering Governor

A Pickering governor is mostly used for driving gramophone. It consists of \*three straight leaf springs arranged at equal angular intervals round the spindle. Each spring carries a weight at the centre. The weights move outwards and the springs bend as they rotate about the spindle axis with increasing speed.

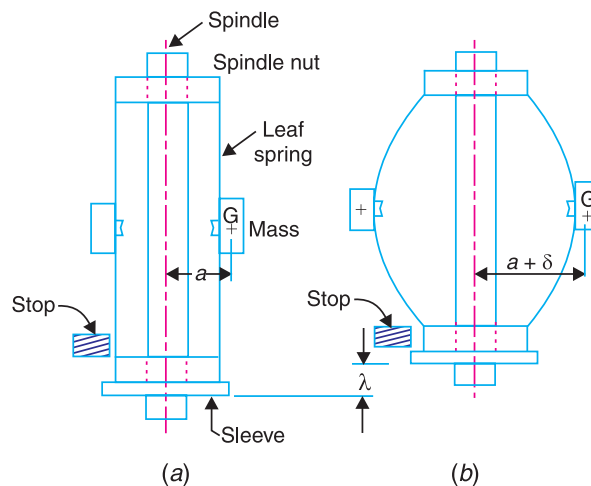

Fig. 18.32. Pickering governor.

In Fig. 18.32 (a), the governor is at rest. When the governor rotates, the springs together with the weights are deflected as shown in Fig. 18.32 (b). The upper end of the spring is attached by a

\* Only two leaf springs are shown in Fig. 18.32.

screw to hexagonal nut fixed to the governor spindle. The lower end of the spring is attached to a sleeve which is free to slide on the spindle. The spindle runs in a bearing at each end and is driven through gearing by the motor. The sleeve can rise until it reaches a stop, whose position is adjustable.

Let  $m$  = Mass attached at the centre of the leaf spring,  
 $a$  = Distance from the spindle axis to the centre of gravity of the mass, when the governor is at rest,  
 $\omega$  = Angular speed of the governor spindle,  
 $\delta$  = Deflection of the centre of the leaf spring at angular speed  $\omega$ ,  
 $a + \delta$  = Distance from the spindle axis to the centre of gravity of the mass, when the governor is rotating, and  
 $\lambda$  = Lift of the sleeve corresponding to the deflection  $\delta$ .

We know that the maximum deflection of a leaf spring with both ends fixed and carrying a load ( $W$ ) at the centre is,

$$\delta = \frac{W \cdot l^3}{192 EI} \quad \dots (i)$$

where

$l$  = Distance between the fixed ends of the spring,

$E$  = Young's modulus of the material of the spring, and

$$I = \text{Moment of inertia of its cross-section about the neutral axis} = \frac{b \cdot t^3}{12}$$

(where  $b$  and  $t$  are width and thickness of spring).

In case of a Pickering governor, the central load is the centrifugal force.

$$\therefore W = F_C = m \cdot \omega^2 (a + \delta) \quad \dots (ii)$$

Substituting the value of  $W$  in equation (i), we have

$$\delta = \frac{m \cdot \omega^2 (a + \delta) l^3}{192 E \cdot I}$$

**Note:** The empirical relation between the lift of the sleeve and the deflection  $\delta$  is,  $\lambda = \frac{2.4 \delta^2}{l}$  approximately.

**Example 18.23.** A gramophone is driven by a Pickering governor. The mass of each disc attached to the centre of a leaf spring is 20 g. The each spring is 5 mm wide and 0.125 mm thick. The effective length of each spring is 40 mm. The distance from the spindle axis to the centre of gravity of the mass when the governor is at rest, is 10 mm. Find the speed of the turntable when the sleeve has risen 0.8 mm and the ratio of the governor speed to the turntable speed is 10.5. Take  $E = 210 \text{ kN/m}^2$ .

**Solution.** Given :  $m = 20 \text{ g} = 0.02 \text{ kg}$  ;  $b = 5 \text{ mm}$  ;  $t = 0.125 \text{ mm}$  ;  $a = 10 \text{ mm} = 0.01 \text{ m}$  ;  $E = 210 \text{ kN/mm}^2 = 210 \times 10^3 \text{ N/mm}^2$

We know that moment of inertia of the spring about its neutral axis,

$$I = \frac{b \cdot t^3}{12} = \frac{5 (0.125)^3}{12} = 0.8 \times 10^{-3} \text{ mm}^4$$

Since the effective length of each spring is 40 mm and lift of sleeve ( $\lambda$ ) = 0.8 mm, therefore Length of spring between fixed ends,

$$l = 40 - 0.8 = 39.2 \text{ mm}$$

We know that the central deflection ( $\lambda$ ),

$$0.8 = \frac{2.4 \delta^2}{l} = \frac{2.4 \delta^2}{39.2} = 0.06 \delta^2$$

## 700 • Theory of Machines

$$\therefore \delta^2 = 0.8/0.06 = 13.3 \quad \text{or} \quad \delta = 3.65 \text{ mm}$$

Let  $N$  = Speed of the governor, and

$N_1$  = Speed of the turntable.

$$\therefore N/N_1 = 10.5 \quad \dots(\text{Given})$$

We know that 
$$\delta = \frac{m \cdot \omega^2 (a + \delta) l^3}{192 E \cdot I}$$

$$3.65 = \frac{0.02 \omega^2 (10 + 3.65) (39.2)^3}{192 \times 210 \times 10^3 \times 0.8 \times 10^{-3}} = \frac{16\,445 \omega^2}{32\,256} = 0.51 \omega^2$$

$$\therefore \omega^2 = \frac{3.65}{0.51} = 7.156 \quad \text{or} \quad \omega = 2.675 \text{ rad/s}$$

and  $N = \omega \times 60/2\pi = 2.675 \times 60/2\pi = 25.5 \text{ r.p.m. Ans.}$

$$\therefore N_1 = N/10.5 = 25.5/10.5 = 2.43 \text{ r.p.m. Ans.}$$

### 18.12. Sensitiveness of Governors

Consider two governors  $A$  and  $B$  running at the same speed. When this speed increases or decreases by a certain amount, the lift of the sleeve of governor  $A$  is greater than the lift of the sleeve of governor  $B$ . It is then said that the governor  $A$  is more sensitive than the governor  $B$ .

In general, the greater the lift of the sleeve corresponding to a given fractional change in speed, the greater is the sensitiveness of the governor. It may also be stated in another way that for a given lift of the sleeve, the sensitiveness of the governor increases as the speed range decreases. This definition of sensitiveness may be quite satisfactory when the governor is considered as an independent mechanism. But when the governor is fitted to an engine, the practical requirement is simply that the change of equilibrium speed from the full load to the no load position of the sleeve should be as small a fraction as possible of the mean equilibrium speed. The actual displacement of the sleeve is immaterial, provided that it is sufficient to change the energy supplied to the engine by the required amount. For this reason, the sensitiveness is defined as the *ratio of the difference between the maximum and minimum equilibrium speeds to the mean equilibrium speed*.

Let  $N_1$  = Minimum equilibrium speed,

$N_2$  = Maximum equilibrium speed, and

$$N = \text{Mean equilibrium speed} = \frac{N_1 + N_2}{2}.$$

$\therefore$  Sensitiveness of the governor

$$= \frac{N_2 - N_1}{N} = \frac{2(N_2 - N_1)}{N_1 + N_2}$$

$$= \frac{2(\omega_2 - \omega_1)}{\omega_1 + \omega_2}$$

... (In terms of angular speeds)

### 18.13. Stability of Governors

A governor is said to be *stable* when for every speed within the working range there is a definite configuration *i.e.* there is only one radius of rotation of the governor balls at which the governor is in equilibrium. For a stable governor, if the equilibrium speed increases, the radius of governor balls must also increase.

**Note :** A governor is said to be unstable, if the radius of rotation decreases as the speed increases.



### 18.14. Isochronous Governors

A governor is said to be **isochronous** when the equilibrium speed is constant (*i.e.* range of speed is zero) for all radii of rotation of the balls within the working range, neglecting friction. The isochronism is the stage of infinite sensitivity.

Let us consider the case of a Porter governor running at speeds  $N_1$  and  $N_2$  r.p.m. We have discussed in Art. 18.6 that

$$(N_1)^2 = \frac{m + \frac{M}{2}(1+q)}{m} \times \frac{895}{h_1} \quad \dots (i)$$

and

$$(N_2)^2 = \frac{m + \frac{M}{2}(1+q)}{m} \times \frac{895}{h_2} \quad \dots (ii)$$

For isochronism, range of speed should be zero *i.e.*  $N_2 - N_1 = 0$  or  $N_2 = N_1$ . Therefore from equations (i) and (ii),  $h_1 = h_2$ , which is impossible in case of a Porter governor. Hence a **Porter governor cannot be isochronous**.

Now consider the case of a Hartnell governor running at speeds  $N_1$  and  $N_2$  r.p.m. We have discussed in Art. 18.8 that

$$M \cdot g + S_1 = 2 F_{C1} \times \frac{x}{y} = 2 \times m \left( \frac{2\pi N_1}{60} \right)^2 r_1 \times \frac{x}{y} \quad \dots (iii)$$

and

$$M \cdot g + S_2 = 2 F_{C2} \times \frac{x}{y} = 2 \times m \left( \frac{2\pi N_2}{60} \right)^2 r_2 \times \frac{x}{y} \quad \dots (iv)$$

For isochronism,  $N_2 = N_1$ . Therefore from equations (iii) and (iv),

$$\frac{M \cdot g + S_1}{M \cdot g + S_2} = \frac{r_1}{r_2}$$

**Note :** The isochronous governor is not of practical use because the sleeve will move to one of its extreme positions immediately the speed deviates from the isochronous speed.

### 18.15. Hunting

A governor is said to be **hunt** if the speed of the engine fluctuates continuously above and below the mean speed. This is caused by a too sensitive governor which changes the fuel supply by a large amount when a small change in the speed of rotation takes place. For example, when the load on the engine increases, the engine speed decreases and, if the governor is very sensitive, the governor sleeve immediately falls to its lowest position. This will result in the opening of the control valve wide which will supply the fuel to the engine in excess of its requirement so that the engine speed rapidly increases again and the governor sleeve rises to its highest position. Due to this movement of the sleeve, the control valve will cut off the fuel supply to the engine and thus the engine speed begins to fall once again. This cycle is repeated indefinitely.

Such a governor may admit either the maximum or the minimum amount of fuel. The effect of this will be to cause wide fluctuations in the engine speed or in other words, the engine will hunt.



A forklift is used to carry small loads from one place to the other inside a factory.

### 18.16. Effort and Power of a Governor

The **effort of a governor** is the mean force exerted at the sleeve for a given percentage change of speed\* (or lift of the sleeve). It may be noted that when the governor is running steadily, there is no force at the sleeve. But, when the speed changes, there is a resistance at the sleeve which opposes its motion. It is assumed that this resistance which is equal to the effort, varies uniformly from a maximum value to zero while the governor moves into its new position of equilibrium.

The **power of a governor** is the work done at the sleeve for a given percentage change of speed. It is the product of the mean value of the effort and the distance through which the sleeve moves. Mathematically,

$$\text{Power} = \text{Mean effort} \times \text{lift of sleeve}$$

### 18.17. Effort and Power of a Porter Governor

The effort and power of a Porter governor may be determined as discussed below.

Let  $N$  = Equilibrium speed corresponding to the configuration as shown in Fig. 18.33 (a), and

$c$  = Percentage increase in speed.

$\therefore$  Increase in speed =  $c.N$

and increased speed =  $N + c.N = N(1 + c)$

The equilibrium position of the governor at the increased speed is shown in Fig. 18.33 (b).

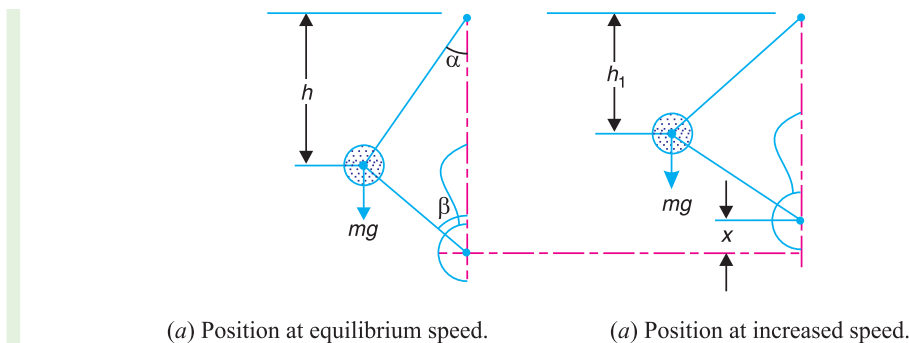

Fig. 18.33

We have discussed in Art. 18.6 that when the speed is  $N$  r.p.m., the sleeve load is  $M.g$ . Assuming that the angles  $\alpha$  and  $\beta$  are equal, so that  $q = 1$ , then the height of the governor,

$$h = \frac{m + M}{m} \times \frac{895}{N^2} \quad (\text{in metres}) \quad \dots (i)$$

When the increase of speed takes place, a downward force  $P$  will have to be exerted on the sleeve in order to prevent the sleeve from rising. If the speed increases to  $(1 + c)N$  r.p.m. and the height of the governor remains the same, the load on the sleeve increases to  $M_1.g$ . Therefore

$$h = \frac{m + M_1}{m} \times \frac{895}{(1 + c)^2 N^2} \quad (\text{in metres}) \quad \dots (ii)$$

Equating equations (i) and (ii), we have

$$m + M = \frac{m + M_1}{(1 + c)^2} \quad \text{or} \quad M_1 = (m + M)(1 + c)^2 - m$$

and  $M_1 - M = (m + M)(1 + c)^2 - m - M = (m + M)[(1 + c)^2 - 1] \quad \dots (iii)$

\* In comparing different types of governors, it is convenient to take the change of speed as one per cent.

A little consideration will show that  $(M_1 - M)g$  is the downward force which must be applied in order to prevent the sleeve from rising as the speed increases. It is the same force which acts on the governor sleeve immediately after the increase of speed has taken place and before the sleeve begins to move. When the sleeve takes the new position as shown in Fig. 18.33 (b), this force gradually diminishes to zero.

Let  $P =$  Mean force exerted on the sleeve during the increase in speed or the effort of the governor.

$$\begin{aligned} \therefore P &= \frac{(M_1 - M)g}{2} = \frac{(m + M)[(1 + c)^2 - 1]g}{2} \\ &= \frac{(m + M)[1 + c^2 + 2c - 1]g}{2} = c(m + M)g \quad \dots (iv) \\ &\dots \text{(Neglecting } c^2, \text{ being very small)} \end{aligned}$$

If  $F$  is the frictional force (in newtons) at the sleeve, then

$$P = c(m.g + M.g \pm F)$$

We have already discussed that the power of a governor is the product of the governor effort and the lift of the sleeve.

Let  $x =$  Lift of the sleeve.

$$\therefore \text{Governor power} = P \times x \quad \dots (v)$$

If the height of the governor at speed  $N$  is  $h$  and at an increased speed  $(1 + c)N$  is  $h_1$ , then

$$x = 2(h - h_1)$$

As there is no resultant force at the sleeve in the two equilibrium positions, therefore

$$h = \frac{m + M}{m} \times \frac{895}{N^2}, \quad \text{and} \quad h_1 = \frac{m + M}{m} \times \frac{895}{(1 + c)^2 N^2},$$

$$\therefore \frac{h_1}{h} = \frac{1}{(1 + c)^2} \quad \text{or} \quad h_1 = \frac{h}{(1 + c)^2}$$

$$\text{We know that} \quad x = 2(h - h_1) = 2 \left[ h - \frac{h}{(1 + c)^2} \right] = 2h \left[ 1 - \frac{1}{(1 + c)^2} \right]$$

$$= 2h \left[ \frac{1 + c^2 + 2c - 1}{1 + c^2 + 2c} \right] = 2h \left( \frac{2c}{1 + 2c} \right) \quad \dots (vi)$$

$\dots$  (Neglecting  $c^2$ , being very small)

Substituting the values of  $P$  and  $x$  in equation (v), we have

$$\text{Governor power} = c(m + M)g \times 2h \left( \frac{2c}{1 + 2c} \right) = \frac{4c^2}{1 + 2c} (m + M)g \cdot h \quad \dots (vii)$$

**Notes : 1.** If  $\alpha$  is not equal to  $\beta$ , i.e.  $\tan \beta / \tan \alpha = q$ , then the equations (i) and (ii) may be written as

$$h = \frac{m + \frac{M}{2}(1 + q)}{m} \times \frac{895}{N^2} \quad \dots (viii)$$

When speed increases to  $(1 + c)N$  and height of the governor remains the same, then

$$h = \frac{m + \frac{M_1}{2}(1 + q)}{m} \times \frac{895}{(1 + c)N^2} \quad \dots (ix)$$

## 704 • Theory of Machines

From equations (viii) and (ix), we have

$$m + \frac{M}{2}(1+q) = \frac{m + \frac{M_1}{2}(1+q)}{(1+c)^2}$$

or 
$$\frac{M_1}{2}(1+q) = \left[ m + \frac{M}{2}(1+q) \right] (1+c)^2 - m$$

$$\therefore \frac{M_1}{2} = \frac{m(1+c)^2}{1+q} + \frac{M}{2}(1+c)^2 - \frac{m}{1+q}$$

or 
$$\begin{aligned} \frac{M_1}{2} - \frac{M}{2} &= \frac{m(1+c)^2}{1+q} + \frac{M}{2}(1+c)^2 - \frac{m}{1+q} - \frac{M}{2} \\ &= \frac{m}{1+q} [(1+c)^2 - 1] + \frac{M}{2} [(1+c)^2 - 1] \\ &= \left[ \frac{m}{1+q} + \frac{M}{2} \right] [(1+c)^2 - 1] \end{aligned}$$

$$\begin{aligned} \therefore \text{Governor effort, } P &= \left( \frac{M_1 - M}{2} \right) g = \left[ \frac{m}{1+q} + \frac{M}{2} \right] [1+c^2 + 2c - 1] g \\ &= \left( \frac{m}{1+q} + \frac{M}{2} \right) (2c) g = \left( \frac{2m}{1+q} + M \right) c \cdot g \quad \dots \text{ (Neglecting } c^2) \end{aligned}$$

The equation (vi) for the lift of the sleeve becomes,

$$x = (1+q) h \left( \frac{2c}{1+2c} \right)$$

$$\begin{aligned} \therefore \text{Governor power} &= P \times x = \left( \frac{2m}{1+q} + M \right) c \cdot g (1+q) h \left( \frac{2c}{1+2c} \right) \\ &= \frac{2c^2}{1+2c} [2m + M(1+q)] g \cdot h = \frac{4c^2}{1+2c} \left[ m + \frac{M}{2}(1+q) \right] g \cdot h \end{aligned}$$

2. The above method of determining the effort and power of a Porter governor may be followed for any other type of the governor.

**Example 18.24.** A Porter governor has equal arms each 250 mm long and pivoted on the axis of rotation. Each ball has a mass of 5 kg and the mass of the central load on the sleeve is 25 kg. The radius of rotation of the ball is 150 mm when the governor begins to lift and 200 mm when the governor is at maximum speed. Find the range of speed, sleeve lift, governor effort and power of the governor in the following cases :

1. When the friction at the sleeve is neglected, and
2. When the friction at the sleeve is equivalent to 10 N.

**Solution.** Given :  $BP = BD = 250$  mm ;  $m = 5$  kg ;  $M = 25$  kg ;  $r_1 = 150$  mm ;  $r_2 = 200$  mm ;  $F = 10$  N

### 1. When the friction at the sleeve is neglected

First of all, let us find the minimum and maximum speed of rotation. The minimum and maximum position of the governor is shown in Fig. 18.34 (a) and (b) respectively.

Let  $N_1$  = Minimum speed, and  
 $N_2$  = Maximum speed.

From Fig. 18.34 (a),

$$h_1 = PG = \sqrt{(BP)^2 - (BG)^2} = \sqrt{(250)^2 - (150)^2} = 200 \text{ mm} = 0.2 \text{ m}$$

From Fig. 18.34 (b),

$$h_2 = PG = \sqrt{(BP)^2 - (BG)^2} = \sqrt{(250)^2 - (200)^2} = 150 \text{ mm} = 0.15 \text{ m}$$

We know that  $(N_1)^2 = \frac{m + M}{m} \times \frac{895}{h_1} = \frac{5 + 25}{5} \times \frac{895}{0.2} = 26\,850$

$\therefore N_1 = 164 \text{ r.p.m.}$

and  $(N_2)^2 = \frac{m + M}{m} \times \frac{895}{h_2} = \frac{5 + 25}{5} \times \frac{895}{0.15} = 35\,800$

$\therefore N_2 = 189 \text{ r.p.m.}$

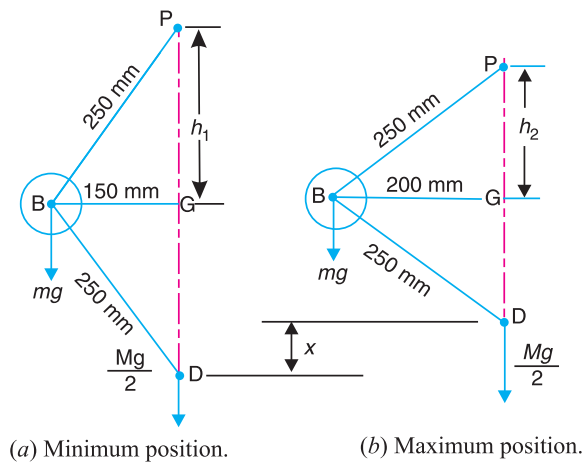

Fig. 18.34

**Range of speed**

We know that range of speed

$$= N_2 - N_1 = 189 - 164 = 25 \text{ r.p.m. Ans.}$$

**Sleeve lift**

We know that sleeve lift,

$$x = 2(h_1 - h_2) = 2(200 - 150) = 100 \text{ mm} = 0.1 \text{ m Ans.}$$

**Governor effort**

Let  $c$  = Percentage increase in speed.

We know that increase in speed or range of speed,

$$c.N_1 = N_2 - N_1 = 25 \text{ r.p.m.}$$

$\therefore c = 25/N_1 = 25/164 = 0.152$

We know that governor effort

$$P = c(m + M)g = 0.152(5 + 25)9.81 = 44.7 \text{ N Ans.}$$

## 706 • Theory of Machines

### Power of the governor

We know that power of the governor

$$= P.x = 44.7 \times 0.1 = 4.47 \text{ N-m Ans.}$$

### 2. When the friction at the sleeve is taken into account

$$\begin{aligned} \text{We know that } (N_1)^2 &= \frac{m.g + (M.g - F)}{m.g} \times \frac{895}{h_1} \\ &= \frac{5 \times 9.81 + (25 \times 9.81 - 10)}{5 \times 9.81} \times \frac{895}{0.2} = 25\,938 \end{aligned}$$

$$\therefore N_1 = 161 \text{ r.p.m.}$$

and

$$\begin{aligned} (N_2)^2 &= \frac{m.g + (M.g + F)}{m.g} \times \frac{895}{h_2} \\ &= \frac{5 \times 9.81 + (25 \times 9.81 + 10)}{5 \times 9.81} \times \frac{895}{0.15} = 37\,016 \end{aligned}$$

$$\therefore N_2 = 192.4 \text{ r.p.m.}$$

### Range of speed

We know that range of speed

$$= N_2 - N_1 = 192.4 - 161 = 31.4 \text{ r.p.m. Ans.}$$

### Sleeve lift

The sleeve lift ( $x$ ) will be same as calculated above.

$$\therefore \text{Sleeve lift, } x = 100 \text{ mm} = 0.1 \text{ m Ans.}$$

### Governor effort

Let  $c$  = Percentage increase in speed.

We know that increase in speed or range of speed,

$$c.N_1 = N_2 - N_1 = 31.4 \text{ r.p.m.}$$

$$\therefore c = 31.4/N_1 = 31.4/161 = 0.195$$

We know that governor effort,

$$\begin{aligned} P &= c(m.g + M.g + F) = 0.195(5 \times 9.81 + 25 \times 9.81 + 10) \text{ N} \\ &= 57.4 \text{ N Ans.} \end{aligned}$$

### Power of the governor

We know that power of the governor

$$= P.x = 57.4 \times 0.1 = 5.74 \text{ N-m Ans.}$$

**Example 18.25.** The upper arms of a Porter governor has lengths 350 mm and are pivoted on the axis of rotation. The lower arms has lengths 300 mm and are attached to the sleeve at a distance of 40 mm from the axis. Each ball has a mass of 4 kg and mass on the sleeve is 45 kg. Determine the equilibrium speed for a radius of rotation of 200 mm and find also the effort and power of the governor for 1 per cent speed change.

**Solution.** Given :  $PB = 350 \text{ mm} = 0.35 \text{ m}$  ;  $BD = 300 \text{ mm} = 0.3 \text{ m}$  ;  $DE = 40 \text{ mm} = 0.04 \text{ m}$  ;  $m = 4 \text{ kg}$  ;  $M = 45 \text{ kg}$  ;  $r = BG = 200 \text{ mm} = 0.2 \text{ m}$  ;  $c = 1\% = 0.01$

**Equilibrium speed**

Let  $N$  = Equilibrium speed.

The equilibrium position of the governor is shown in Fig. 18.35. From the geometry of the figure,

$$h = PG = \sqrt{(PB)^2 - (BG)^2}$$

$$= \sqrt{(0.35)^2 - (0.2)^2} = 0.287 \text{ m}$$

$$\tan \alpha = \frac{BG}{PG} = \frac{0.2}{0.287} = 0.697$$

$$\therefore BH = BG - HG = 0.2 - 0.04 = 0.16 \text{ m}$$

... ( $\because HG = DE$ )

and

$$DH = \sqrt{(BD)^2 - (BH)^2}$$

$$= \sqrt{(0.3)^2 - (0.16)^2} = 0.254 \text{ m}$$

$$\therefore \tan \beta = BH/DH = 0.16 / 0.254 = 0.63$$

and

$$q = \frac{\tan \beta}{\tan \alpha} = \frac{0.63}{0.697} = 0.904$$

We know that

$$N^2 = \frac{m + \frac{M}{2}(1 + q)}{m} \times \frac{895}{h} = \frac{4 + \frac{45}{2}(1 + 0.904)}{4} \times \frac{895}{0.287} = 36\,517$$

$$\therefore N = 191 \text{ r.p.m. Ans.}$$

**Effort of the governor**

We know that effort of the governor,

$$P = c \left( \frac{2m}{1 + q} + M \right) g = 0.01 \left( \frac{2 \times 4}{1 + 0.904} + 45 \right) 9.81 = 4.8 \text{ N Ans.}$$

**Power of the governor**

We know that power of the governor

$$= \frac{4c^2}{1 + 2c} \left[ m + \frac{M}{2}(1 + q) \right] g \cdot h$$

$$= \frac{4(0.01)^2}{1 + 2 \times 0.01} \left[ 4 + \frac{45}{2}(1 + 0.904) \right] 9.81 \times 0.287 = 0.052 \text{ N-m}$$

$$= 52 \text{ N-mm Ans.}$$

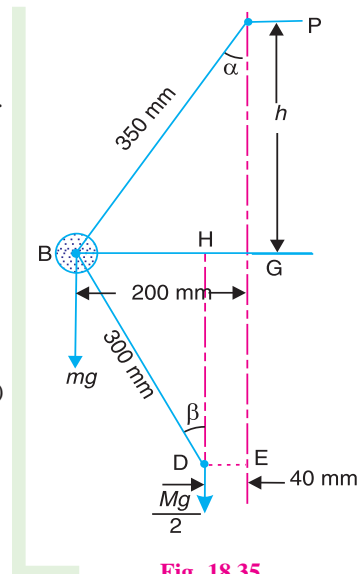

Fig. 18.35

**Example 18.26.** The radius of rotation of the balls of a Hartnell governor is 80 mm at the minimum speed of 300 r.p.m. Neglecting gravity effect, determine the speed after the sleeve has lifted by 60 mm. Also determine the initial compression of the spring, the governor effort and the power.

The particulars of the governor are given below:

Length of ball arm = 150 mm ; length of sleeve arm = 100 mm ; mass of each ball = 4 kg ; and stiffness of the spring = 25 N/mm.

## 708 • Theory of Machines

**Solution.** Given :  $r_1 = 80 \text{ mm} = 0.08 \text{ m}$  ;  $N_1 = 300 \text{ r.p.m.}$  or  $\omega_1 = 2\pi \times 300/60 = 31.42 \text{ rad/s}$  ;  
 $h = 60 \text{ mm} = 0.06 \text{ m}$  ;  $x = 150 \text{ mm} = 0.15 \text{ m}$  ;  $y = 100 \text{ mm} = 0.1 \text{ m}$  ;  $m = 4 \text{ kg}$  ;  $s = 25 \text{ N/mm}$

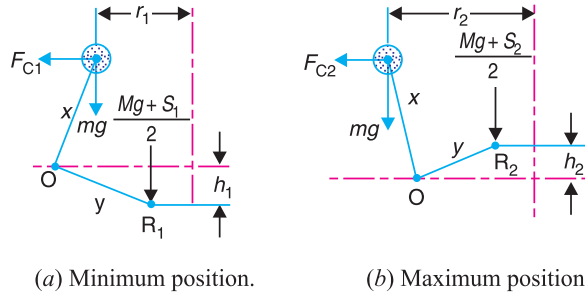

Fig. 18.36

The minimum and maximum position of the governor is shown in Fig. 18.36 (a) and (b) respectively. First of all, let us find the maximum radius of rotation ( $r_2$ ). We know that lift of the sleeve,

$$h = (r_2 - r_1) \frac{y}{x}$$

or 
$$r_2 = r_1 + h \times \frac{x}{y} = 0.08 + 0.06 \times \frac{0.15}{0.1} = 0.17 \text{ m} \quad \dots (\because h = h_1 + h_2)$$

### Maximum speed of rotation

Let  $N_2 =$  Maximum speed of rotation, and

$S_1$  and  $S_2 =$  Spring force at the minimum and maximum speed respectively, in newtons.

We know centrifugal force at the minimum speed,

$$F_{C1} = m (\omega_1)^2 r_1 = 4 (31.42)^2 0.08 = 316 \text{ N}$$

Now taking moments about the fulcrum  $O$  of the bell crank lever when in minimum position as shown in Fig 18.36 (a). The gravity effect is neglected, *i.e.* the moment due to the weight of balls, sleeve and the bell crank lever arms is neglected.

$$\therefore F_{C1} \times x = \frac{M \cdot g + S_1}{2} \times y \quad \text{or} \quad S_1 = 2 F_{C1} \times \frac{x}{y} = 2 \times 316 \times \frac{0.15}{0.1} = 948 \text{ N}$$

$\dots (\because M = 0)$

We know that  $S_2 - S_1 = h \cdot s$  or  $S_2 = S_1 + h \cdot s = 948 + 60 \times 25 = 2448 \text{ N}$

We know that centrifugal force at the maximum speed,

$$F_{C1} = m (\omega_2)^2 r_2 = \left( \frac{2\pi N_2}{60} \right)^2 r_2 = m \left( \frac{2\pi N_2}{60} \right)^2 0.17 = 0.00746 (N_2)^2$$

Now taking moments about the fulcrum  $O$  when in maximum position, as shown in Fig. 18.36 (b),

$$F_{C2} \times x = \frac{M \cdot g + S_2}{2} \times y$$

$$0.00746 (N_2)^2 0.15 = \frac{2448}{2} \times 0.1 \quad \text{or} \quad 0.00112 (N_2)^2 = 122.4 \quad \dots (\because M = 0)$$

$$(N_2)^2 = \frac{122.4}{0.00112} = 109286 \quad \text{or} \quad N_2 = 331 \text{ r.p.m. Ans.}$$



**Initial compression of the spring**

We know that initial compression of the spring

$$= \frac{S_1}{s} = \frac{948}{25} = 37.92 \text{ mm Ans.}$$

**Governor effort**

We know that the governor effort,

$$P = \frac{S_2 - S_1}{2} = \frac{2448 - 948}{2} = 750 \text{ N Ans.}$$

**Governor power**

We know that the governor power

$$= P \times h = 750 \times 0.06 = 45 \text{ N-m Ans.}$$

**Example 18.27.** In a Hartnell governor, the lengths of ball and sleeve arms of a bell crank lever are 120 mm and 100 mm respectively. The distance of the fulcrum of the bell crank lever from the governor axis is 140 mm. Each governor ball has a mass of 4 kg. The governor runs at a mean speed of 300 r.p.m. with the ball arms vertical and sleeve arms horizontal. For an increase of speed of 4 per cent, the sleeve moves 10 mm upwards. Neglecting friction, find :

1. the minimum equilibrium speed if the total sleeve movement is limited to 20 mm, 2. the spring stiffness, 3. the sensitiveness of the governor, and 4. the spring stiffness if the governor is to be isochronous at 300 r.p.m.

**Solution.** Given :  $x = 120 \text{ mm} = 0.12 \text{ m}$  ;  $y = 100 \text{ mm} = 0.1 \text{ m}$  ;  $r = 140 \text{ mm} = 0.14 \text{ m}$  ;  $m = 4 \text{ kg}$  ;  $N = 300 \text{ r.p.m.}$  or  $\omega = 2\pi \times 300/60 = 31.42 \text{ rad/s}$  ;  $h_1 = 10 \text{ mm} = 0.01 \text{ m}$  ;  $h = 20 \text{ mm} = 0.02 \text{ m}$

**1. Minimum equilibrium speed**

Let  $N_1 =$  Minimum equilibrium speed,

$r_1 =$  Radius of rotation in the minimum position, i.e. when the sleeve moves downward, and

$r_2 =$  Radius of rotation in the maximum position, i.e. when the sleeve moves upward.

Since the increase in speed is 4%, therefore maximum speed,

$$N_2 = N + 0.04 N = 1.04 N = 1.04 \times 300 = 312 \text{ r.p.m.}$$

or  $\omega_2 = 2\pi \times 312 / 60 = 32.7 \text{ rad/s}$

We know that lift of the sleeve for the maximum position,

$$h_2 = h - h_1 = 0.02 - 0.01 = 0.01 \text{ m}$$

Now for the minimum position,

$$\frac{h_1}{y} = \frac{r - r_1}{x} \quad \text{or} \quad r_1 = r - h_1 \times \frac{x}{y} = 0.14 - 0.01 \times \frac{0.12}{0.1} = 0.128 \text{ m}$$

Similarly for the maximum position,

$$\frac{h_2}{y} = \frac{r_2 - r}{x} \quad \text{or} \quad r_2 = r + h_2 \times \frac{x}{y} = 0.14 + 0.01 \times \frac{0.12}{0.1} = 0.152 \text{ m}$$

We know that centrifugal force in the mean position,

$$F_C = m \cdot \omega^2 \cdot r = 4 (31.42)^2 \cdot 0.14 = 553 \text{ N}$$

Centrifugal force in the minimum position,

$$F_{C1} = m (\omega_1)^2 r_2 = 4 \left( \frac{2\pi N_1}{60} \right)^2 \cdot 0.128 = 0.0056 (N_1)^2 \quad \dots (i)$$

## 710 • Theory of Machines

and centrifugal force in the maximum position,

$$F_{C2} = m \cdot (\omega_2)^2 r_2 = 4 (32.7)^2 0.152 = 650 \text{ N}$$

We know that centrifugal force at any instant,

$$F_C = F_{C1} + (F_{C2} - F_{C1}) \left( \frac{r - r_1}{r_2 - r_1} \right)$$

$$553 = F_{C1} + (650 - F_{C1}) \left( \frac{0.14 - 0.128}{0.152 - 0.128} \right) = 0.5 F_{C1} + 325$$

$$\therefore F_{C1} = \frac{553 - 325}{0.5} = 456 \text{ N} \quad \dots (ii)$$

From equations (i) and (ii),

$$(N_1)^2 = \frac{456}{0.0056} = 81\,428 \quad \text{or} \quad N_1 = 285.4 \text{ r.p.m. Ans.}$$

### 2. Spring stiffness

Let  $S_1$  and  $S_2$  = Spring force at the minimum and maximum position.

Neglecting the effect of obliquity of arms, we have for the minimum position,

$$\frac{M \cdot g + S_1}{2} \times y = F_{C1} \times x \quad \text{or} \quad S_1 = 2 F_{C1} \times \frac{x}{y} = 2 \times 456 \times \frac{0.12}{0.1} = 1094.4 \text{ N}$$

... ( $\because M = 0$ )

and for the maximum position,

$$\frac{M \cdot g + S_2}{2} \times y = F_{C2} \times x \quad \text{or} \quad S_2 = 2 F_{C2} \times \frac{x}{y} = 2 \times 650 \times \frac{0.12}{0.1} = 1560 \text{ N}$$

We know that spring stiffness,

$$s = \frac{S_2 - S_1}{h} = \frac{1560 - 1064.4}{20} = 23.28 \text{ N/mm Ans.}$$

### 3. Sensitiveness of the governor

We know that sensitiveness of the governor

$$= \frac{2(N_2 - N_1)}{N_1 + N_2} = \frac{2(312 - 285.4)}{285.4 + 312} = 0.089 \quad \text{or} \quad 8.9\% \text{ Ans.}$$

### 4. Spring stiffness for the governor to be isochronous at 300 r.p.m.

The governor is isochronous, when  $N = N_1 = N_2 = 300$  r.p.m. or  $\omega = \omega_1 = \omega_2 = 31.42$  rad/s

$$\therefore F_{C1} = m \cdot \omega^2 \cdot r_1 = 4 (31.42)^2 0.128 = 505.5 \text{ N}$$

and  $F_{C2} = m \cdot \omega^2 \cdot r_2 = 4 (31.42)^2 0.152 = 600 \text{ N}$

We know that  $S_1 = 2 F_{C1} \times \frac{x}{y} = 2 \times 505.5 \times \frac{0.12}{0.1} = 1213 \text{ N}$

and  $S_2 = 2 F_{C2} \times \frac{x}{y} = 2 \times 600 \times \frac{0.12}{0.1} = 1440 \text{ N}$

$$\therefore \text{Spring stiffness, } s = \frac{S_2 - S_1}{h} = \frac{1440 - 1213}{20} = 11.35 \text{ N/mm Ans.}$$

### 18.18. Controlling Force

We have seen earlier that when a body rotates in a circular path, there is an inward radial force or centripetal force acting on it. In case of a governor running at a steady speed, the inward force acting on the rotating balls is known as **controlling force**. It is equal and opposite to the centrifugal reaction.

$$\therefore \text{Controlling force, } F_C = m.\omega^2.r$$

The controlling force is provided by the weight of the sleeve and balls as in Porter governor and by the spring and weight as in Hartnell governor (or spring controlled governor).

When the graph between the controlling force ( $F_C$ ) as ordinate and radius of rotation of the balls ( $r$ ) as abscissa is drawn, then the graph obtained is known as **controlling force diagram**. This diagram enables the stability and sensitiveness of the governor to be examined and also shows clearly the effect of friction.

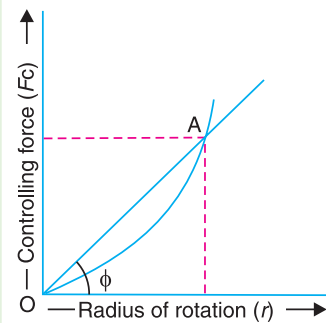

**Fig. 18.37.** Controlling force diagram.

### 18.19. Controlling Force Diagram for Porter Governor

The controlling force diagram for a Porter governor is a curve as shown in Fig. 18.37. We know that controlling force,

$$F_C = m.\omega^2.r = m \left( \frac{2\pi N}{60} \right)^2 r$$

or 
$$N^2 = \frac{1}{m} \left( \frac{60}{2\pi} \right)^2 \left( \frac{F_C}{r} \right) = \frac{1}{m} \left( \frac{60}{2\pi} \right)^2 (\tan \phi) \quad \dots \left[ \because \frac{F_C}{r} = \tan \phi \right]$$

$$\therefore N = \frac{60}{2\pi} \left( \frac{\tan \phi}{m} \right)^{1/2} \quad \dots (i)$$

where  $\phi$  is the angle between the axis of radius of rotation and a line joining a given point (say A) on the curve to the origin O.

**Notes : 1.** In case the governor satisfies the condition for stability, the angle  $\phi$  must increase with radius of rotation of the governor balls. In other words, the equilibrium speed must increase with the increase of radius of rotation of the governor balls.

**2.** For the governor to be more sensitive, the change in the value of  $\phi$  over the change of radius of rotation should be as small as possible.

**3.** For the isochronous governor, the controlling force curve is a straight line passing through the origin. The angle  $\phi$  will be constant for all values of the radius of rotation of the governor. From equation (i)

$$\tan \phi = \frac{F_C}{r} = \frac{m.\omega^2.r}{r} = m.\omega^2 = m \left( \frac{2\pi N}{60} \right)^2 = C.N^2$$

where 
$$C = m \left( \frac{2\pi}{60} \right)^2 = \text{constant}$$

Using the above relation, the angle  $\phi$  may be determined for different values of  $N$  and the lines are drawn from the origin\*. These lines enable the equilibrium speed corresponding to a given radius of rotation to be determined. Alternatively, the same results may be obtained more simply by setting-off a speed scale along any arbitrarily chosen ordinate. The controlling force is calculated for one constant radius of rotation and for different arbitrarily chosen values of speed. The values thus obtained are set-off along the ordinate that corresponds to the chosen radius and marked with the appropriate speeds.

\* See Example 18.28, Fig. 18.39.

712 • Theory of Machines

**Example 18.28.** In a Porter governor, the length of each arm is 300 mm and all the arms are pivoted on the axis of rotation. The mass of each ball is 7.5 kg and the mass of the sleeve is 45 kg. The extreme radii of rotation are 150 mm and 225 mm. Draw the controlling force curve and set-off a speed scale along the ordinate corresponding to a radius of 250 mm.

**Solution.** Given :  $l = 300 \text{ mm} = 0.3 \text{ m}$  ;  $m = 7.5 \text{ kg}$  ;  $r_1 = 150 \text{ mm} = 0.15 \text{ m}$  ;  $r_2 = 225 \text{ mm} = 0.225 \text{ m}$

Let  $F_C =$  Controlling force.

We have discussed in Art 18.6 that

$$\left(\frac{M \cdot g}{2} + m \cdot g\right) \tan \alpha = F_C - \frac{M \cdot g}{2} \times \tan \beta$$

$$\begin{aligned} \therefore F_C &= \left(\frac{M \cdot g}{2} + m \cdot g\right) \tan \alpha + \frac{M \cdot g}{2} \times \tan \beta \\ &= \left(\frac{M \cdot g}{2} + m \cdot g + \frac{M \cdot g}{2} \times \frac{\tan \beta}{\tan \alpha}\right) \tan \alpha \end{aligned}$$

Substituting  $\frac{\tan \beta}{\tan \alpha} = q$ , and  $\tan \alpha = \frac{r}{h}$ , we get

$$F_C = \left[\frac{M \cdot g}{2} (1 + q) + m \cdot g\right] \frac{r}{h}$$

Since  $\alpha = \beta$  as shown in Fig. 18.38, therefore  $q = 1$ .

$$\therefore F_C = (m \cdot g + M \cdot g) \frac{r}{h} = g (m + M) \times \frac{r}{\sqrt{l^2 - r^2}} \quad \dots \left[ \because h = \sqrt{l^2 - r^2} \right]$$

The following table shows the values of  $F_C$  for different values of  $r$ .

$r$ (in metres)	0.025	0.05	0.075	0.1	0.125	0.15	0.175	0.2	0.225	0.25
$h = \sqrt{l^2 - r^2}$	0.2894	0.2958	0.2905	0.2828	0.2727	0.2598	0.2437	0.2236	0.1985	0.1658
$F_C$ (in newtons)	44.5	87	133	182	236	297	370	461	584	776

These values are plotted to draw the controlling force curve as shown in Fig. 18.39. In order to set-off the speed scale along the ordinate through  $r = 250 \text{ mm} = 0.25 \text{ m}$ , we have

$$F_C = m \cdot \omega^2 \cdot r = 7.5 \left(\frac{2\pi N}{60}\right)^2 \cdot 0.25 = 0.02 N^2$$

The values of  $F_C$  for different values of  $N$  are given in the following table.

$N$ (in r.p.m.)	100	125	150	160	170	180	190	200
$F_C$ (in newtons)	200	312.5	450	512	578	648	722	800

The speed scale is now marked on the graph as shown in Fig. 18.39.

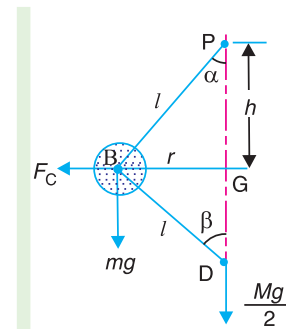

Fig. 18.38

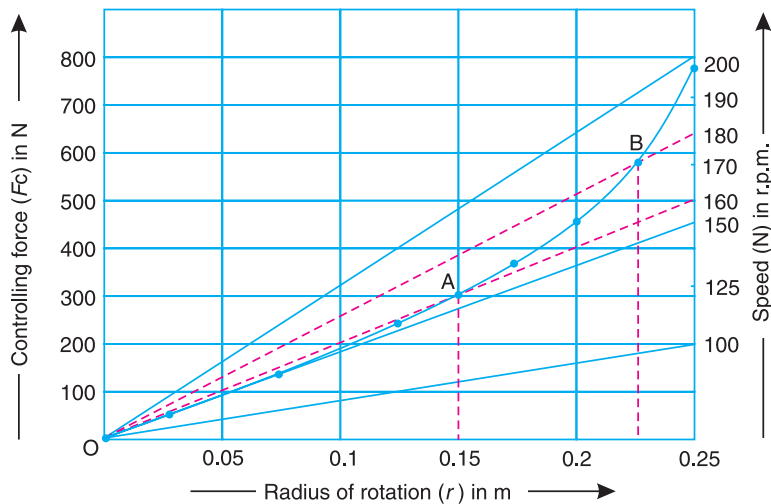

Fig. 18.39

The range of equilibrium speeds for the governor is obtained by drawing lines from the origin (shown dotted in Fig. 18.39) through the two points A (when  $r = 0.15$  m) and B (when  $r = 0.225$  m) on the controlling force curve.

From the graph, we see that these lines intersect the speed scale at approximately 160 r.p.m. and 180 r.p.m. **Ans.**

### 18.20. Controlling Force Diagram for Spring-controlled Governors

The controlling force diagram for the spring controlled governors is a straight line, as shown in Fig. 18.40. We know that controlling force,

$$F_C = m.\omega^2.r \quad \text{or} \quad F_C/r = m.\omega^2$$

The following points, for the stability of spring-controlled governors, may be noted :

1. For the governor to be stable, the controlling force ( $F_C$ ) must increase as the radius of rotation ( $r$ ) increases, i.e.  $F_C/r$  must increase as  $r$  increases. Hence the controlling force line AB when produced must intersect the controlling force axis below the origin, as shown in Fig. 18.40.

The relation between the controlling force ( $F_C$ ) and the radius of rotation ( $r$ ) for the **stability** of spring controlled governors is given by the following equation

$$F_C = a.r - b \quad \dots (i)$$

where  $a$  and  $b$  are constants.

2. The value of  $b$  in equation (i) may be made either zero or positive by increasing the initial tension of the spring. If  $b$  is zero, the controlling force line CD passes through the origin and the governor becomes **isochronous** because  $F_C/r$  will remain constant for all radii of rotation.

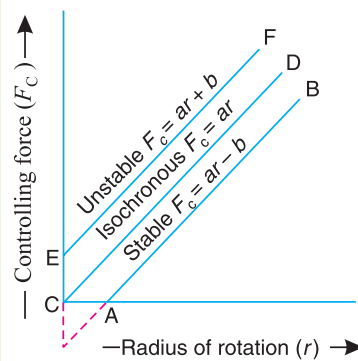

Fig. 18.40

The relation between the controlling force and the radius of rotation, for an **isochronous governor** is, therefore,

$$F_C = a.r \quad \dots (ii)$$

3. If  $b$  is greater than zero or positive, then  $F_C/r$  decreases as  $r$  increases, so that the equilibrium speed of the governor decreases with an increase of the radius of rotation of balls, which is impracticable.

714 • Theory of Machines

Such a governor is said to be *unstable* and the relation between the controlling force and the radius of rotation is, therefore

$$F_C = a.r + b \quad \dots (iii)$$

**Example 18.29.** The particulars of a governor of the type as shown in Fig. 18.41, are as follows:

The mass of each ball is 1.5 kg and the mass of the sleeve is 7.5 kg. The lengths of the ball arm and sleeve arm of the bell crank lever are 112.5 mm and 50 mm respectively and are at right angles to each other. The extreme radii of rotation are 62.5 mm and 112.5 mm. At the minimum radius, the ball arm is vertical and the spring load is 160 N. The spring stiffness is 10.5 N/mm. Draw the controlling force curve and mark the speed scale along the ordinate through 125 mm.

**Solution.** Given :  $m = 1.5 \text{ kg}$  ;  $M = 7.5 \text{ kg}$  ;  
 $x = 112.5 \text{ mm} = 0.1125 \text{ m}$  ;  $y = 50 \text{ mm} = 0.05 \text{ m}$  ;  $r_1 = 62.5 \text{ mm}$   
 $= 0.0625 \text{ m}$  ;  $r_2 = 112.5 \text{ mm} = 0.1125 \text{ m}$  ;  $S_1 = 160 \text{ N}$  ;  
 $s = 10.5 \text{ N/mm} = 10\,500 \text{ N/m}$

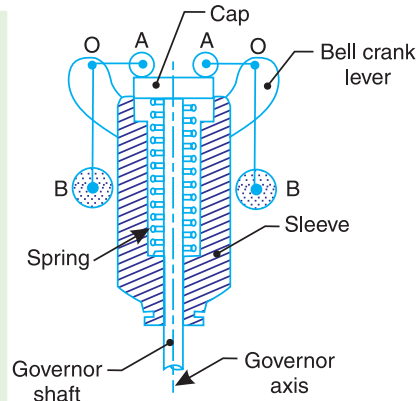

Fig. 18.41

Let  $S_1$  and  $S_2$  be the spring loads at the minimum and maximum radius of rotation.

The minimum and maximum position of the balls is shown in Fig. 18.42 (a) and (b) respectively. Taking moments about the instantaneous centre  $I$ , for the maximum position as shown in Fig. 18.42 (b),

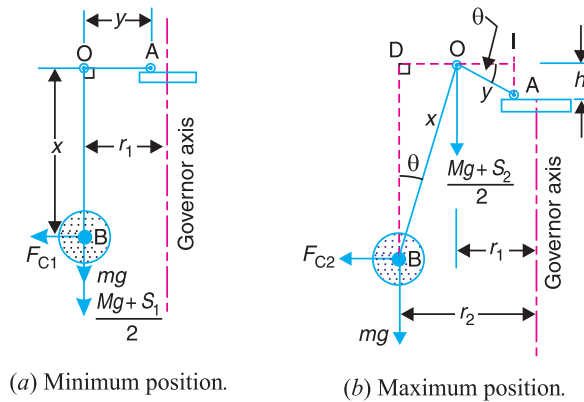

Fig. 18.42

$$F_{C2} \times BD = m.g \times ID + \frac{M.g + S_2}{2} \times IO$$

or 
$$F_{C2} \times x \cos \theta = m.g (x \sin \theta + y \cos \theta) + \frac{M.g + S_2}{2} \times y \cos \theta$$

$$\therefore F_{C2} = m.g \left( \tan \theta + \frac{y}{x} \right) + \frac{M.g + S_2}{2} \times \frac{y}{x} \quad \dots (i)$$

We know that

$$\begin{aligned} S_2 - S_1 &= h.s = y \sin \theta \times s \\ \therefore S_2 &= S_1 + y \sin \theta \times s = 160 + 0.05 \times \sin \theta \times 10\,500 \\ &= 160 + 525 \sin \theta \quad \dots (ii) \end{aligned}$$

Now the equation (i) may be written as

$$F_{C2} = 1.5 \times 9.81 \left( \tan \theta + \frac{0.05}{0.1125} \right) + \frac{7.5 \times 9.81 + 160 + 525 \sin \theta}{2} \times \frac{0.05}{0.1125}$$

$$= 14.7 \tan \theta + 116.5 \sin \theta + 58.5 \quad \dots(iii)$$

From the geometry of Fig. 18.42 (b), we find that

$$r_2 = r_1 + OD = r_1 + x \sin \theta = 0.0625 + 0.1125 \sin \theta \quad \dots(iv)$$

In order to determine the controlling force and the radius of rotation of the ball for different values of  $\theta$ , the angle  $\theta$  is treated as variable. From equations (iii) and (iv), the values of controlling force ( $F_C$ ) and radius of rotation ( $r$ ) for different values of  $\theta$  are tabulated below :

$\theta^\circ$	0	5	10	15	20	25	30
$\sin \theta$	0	0.0871	0.1736	0.2588	0.342	0.4226	0.5
$\tan \theta$	0	0.0875	0.1763	0.2679	0.364	0.4663	0.5773
$F_C$ (N)	58.5	70	81.3	92.6	103.7	114.6	125.2
$r$ (m)	0.0625	0.0723	0.082	0.092	0.101	0.11	0.1187

The graph between  $F_C$  and  $r$  is plotted as shown in Fig. 18.43. It may be seen that the controlling force curve is nearly a straight line.

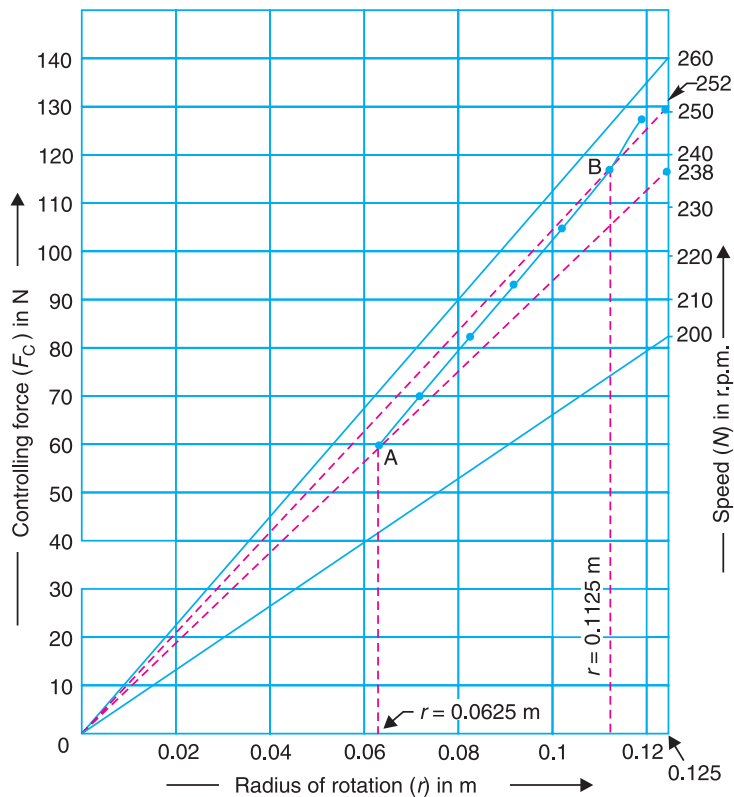

Fig. 18.43

## 716 • Theory of Machines

In order to set off the speed scale along the ordinate through  $r = 125 \text{ mm} = 0.125 \text{ m}$ ,

$$F_C = m \cdot \omega^2 \cdot r = 1.5 \left( \frac{2\pi N}{60} \right)^2 0.125 = 0.00206 N^2$$

The corresponding values of  $F_C$  and  $N$  are given in the following table :

$N$ (r.p.m.)	200	210	220	230	240	250	260
$F_C$ (N)	82.4	90.8	99.7	109	118.6	128.7	139.2

The speed scale is now marked on the graph as shown in Fig. 18.43. The range of equilibrium speeds for the governor is obtained by drawing lines from the origin (shown dotted in Fig. 18.43) through the two points  $A$  (when  $r = 0.0625 \text{ m}$ ) and  $B$  (when  $r = 0.1125 \text{ m}$ ) on the controlling force curve.

From the graph we see that these lines intersect the speed scale at approximately 238 r.p.m. and 252 r.p.m. **Ans.**

### 18.21. Coefficient of Insensitiveness

In the previous articles, we have assumed the governor to be frictionless. In actual practice, there is always friction in the joints and operating mechanism of the governor. Since the frictional force always acts in the opposite direction to that of motion, therefore, when the speed of rotation decreases, the friction prevents the downward movement of the sleeve and the radial inward movement of the balls. On the other hand, when the speed of rotation increases, the friction prevents the upward movement of the sleeve and radial outward movement of the balls.

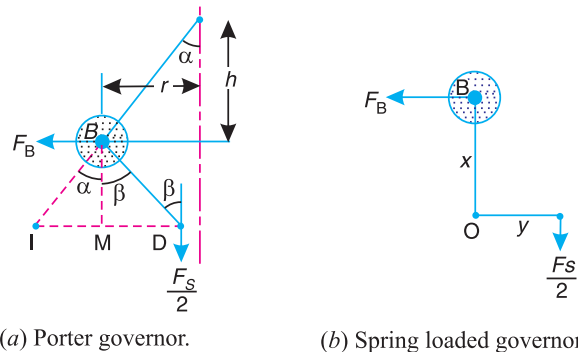

**Fig. 18.44**

Let

$F_S$  = Force required at the sleeve to overcome friction,

$F_B$  = Corresponding radial force required at each ball,

$F_C$  = Controlling force on each ball, and

$W$  = Total load on the sleeve =  $M.g$ .

∴ For decrease in speed, sleeve load (taking friction into account),

$$W_1 = W - F_S \quad \text{or} \quad M_1.g = M.g - F_S$$

and for increase in speed, sleeve load (taking friction into account),

$$W_2 = W + F_S \quad \text{or} \quad M_1.g = M.g + F_S$$

Similarly, for decrease in speed, controlling force,

$$F_{C1} = F_C - F_B$$

and for increase in speed, controlling force,

$$F_{C2} = F_C + F_B$$



Thus for a Porter governor, as shown Fig. 18.44 (a), the relation between  $F_S$  and  $F_B$  may be obtained by taking moments about the instantaneous centre  $I$ .

$$\begin{aligned} \therefore F_B \times BM &= \frac{F_S}{2} (IM + MD) \\ \text{or } F_B &= \frac{F_S}{2} \left( \frac{IM + MD}{BM} \right) = \frac{F_S}{2} (\tan \alpha + \tan \beta) = \frac{F_S}{2} \left( 1 + \frac{\tan \beta}{\tan \alpha} \right) \tan \alpha \\ &= \frac{F_S}{2} (1 + q) \tan \alpha = \frac{F_S}{2} (1 + q) \frac{r}{h} \quad \dots (i) \\ &\dots \left( \because q = \frac{\tan \beta}{\tan \alpha}, \text{ and } \tan \alpha = \frac{r}{h} \right) \end{aligned}$$

Similarly, for spring loaded governors as shown in Fig. 18.44 (b), taking moments about the fulcrum  $O$  of the bell crank lever,

$$F_B \times x = \frac{F_S}{2} \times y \quad \text{or} \quad F_B = F_S \times \frac{y}{2x} \quad \dots (ii)$$

Fig. 18.45 shows the effect of friction on the controlling force diagram. We see that for one value of the radius of rotation (*i.e.*  $OA$ ), there are three values of controlling force as discussed below:

1. For speed decreasing, the controlling force reduces to  $F_{C1}$  (or  $AD$ ) and the corresponding speed on the speed scale is  $N'$ .
2. For speed increasing, the controlling force increases to  $F_{C2}$  (or  $AC$ ) and the corresponding speed on the speed scale is  $N''$ .
3. For friction neglected, the controlling force is  $F_C$  (or  $AB$ ) and the corresponding speed on the speed scale is  $N$ .

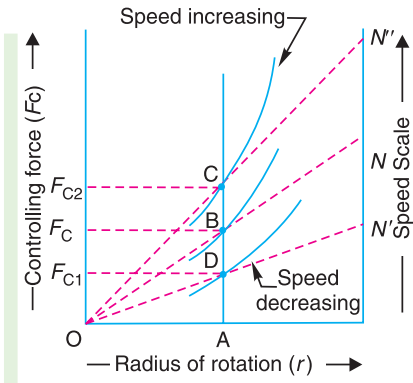

Fig. 18.45. Effect of friction on controlling force.

From above, it is concluded that when the radius of rotation is  $OA$ , the speed of rotation may vary within the limits  $N'$  and  $N''$  without causing any displacement (up or down) of the governor sleeve. The governor is said to be **insensitive** if the speed fluctuates over this range.

The ratio  $\frac{N'' - N'}{N}$  is called the **coefficient of insensitiveness** of the governor.

Since the controlling force is proportional to the square of the speed at a given radius, therefore for a governor speed  $N$ ,

$$F_C \propto N^2 \quad \text{or} \quad F_C = C.N^2 \quad \dots (iii)$$

Similarly, for speed  $N'$ ,

$$F_{C1} = C (N')^2 \quad \dots (iv)$$

and for speed  $N''$ ,

$$F_{C2} = C (N'')^2 \quad \dots (v)$$

Subtracting equation (iv) from equation (v), we have

$$F_{C2} - F_{C1} = C [(N'')^2 - (N')^2]$$

$$\text{or } (F_C + F_B) - (F_C - F_B) = C [(N'')^2 - (N')^2]$$

$$2F_B = C [(N'')^2 - (N')^2] \quad \dots (vi)$$

## 718 • Theory of Machines

Dividing equation (vi) by equation (iii)

$$\frac{2F_B}{F_C} = \frac{(N'')^2 - (N')^2}{N^2} = \frac{(N'' + N')(N'' - N')}{N^2} = \frac{N'' + N'}{N} \times \frac{N'' - N'}{N}$$

Since  $\frac{N'' + N'}{2}$  is approximately equal to  $N$ , therefore

$$\frac{2F_B}{F_C} = 2 \times \frac{N'' - N'}{N}$$

∴ Coefficient of insensitiveness

$$= \frac{N'' - N'}{N} = \frac{F_B}{F_C} \quad \dots \text{(vii)}$$

**Notes : 1** In case of a Porter governor, as shown in Fig. 18.44 (a), (i.e. when the lower arm is not attached on the governor axis),

$$F_B = \frac{F_S}{2} (1 + q) \frac{r}{h}$$

∴ Coefficient of insensitiveness

$$= \frac{N'' - N'}{N} = \frac{F_B}{F_C} = \frac{F_S}{2 F_C} (1 + q) \frac{r}{h} \quad \dots \text{(viii)}$$

2. When all the arms of a Porter governor are attached to the governor axis, then  $q = 1$ . In that case,

$$F_B = F_S \times \frac{r}{h}$$

∴ Coefficient of insensitiveness

$$= \frac{N'' - N'}{N} = \frac{F_B}{F_C} = \frac{F_S}{F_C} \times \frac{r}{h} \quad \dots \text{(ix)}$$

3. In case of a Porter governor when all the arms are attached to the governor axis, the coefficient of insensitiveness may also be determined as discussed below :

Let  $h$  = Height of the governor at the mean speed  $N$ , when friction is neglected,

$F$  = Frictional force on the sleeve,

$N'$  and  $N''$  = Minimum and maximum speed when friction is taken into account.

We have discussed above that the governor is insensitive when the sleeve does not move downwards when the speed falls to  $N'$  or upwards when the speed rises to  $N''$ . In other words, the height of the governor ( $h$ ) remains the same for minimum and maximum speeds  $N'$  and  $N''$  respectively. We know that

$$N^2 = \frac{m + M}{m} \times \frac{895}{h}$$

Similarly,

$$(N')^2 = \frac{m \cdot g + (M \cdot g - F)}{m \cdot g} \times \frac{895}{h}$$

and

$$(N'')^2 = \frac{m \cdot g + (M \cdot g + F)}{m \cdot g} \times \frac{895}{h}$$

Now

$$(N'')^2 - (N')^2 = (N'' + N')(N'' - N') = 2N(N'' - N') \quad \dots \left( \because N = \frac{N'' + N'}{2} \right)$$

∴

$$N'' - N' = \frac{(N'')^2 - (N')^2}{2N}$$

and coefficient of insensitiveness

$$\begin{aligned}
 &= \frac{N'' - N'}{N} = \frac{(N'')^2 - (N')^2}{2 N^2} = \frac{m \cdot g + (M \cdot g + F) - m \cdot g + (M \cdot g - F)}{2 \left( \frac{m + M}{m} \right)} \\
 &= \frac{1}{2} \left[ \frac{2 F}{(m + M) g} \right] = \frac{F}{(m + M) g} \quad \dots(x)
 \end{aligned}$$

4. In case of a Porter governor, when the upper arms are pivoted to the governor axis and the lower arms are at a certain distance from the governor axis *i.e.* when  $\alpha$  is not equal to  $\beta$  (Refer Art. 18.6), then it may be proved that

Coefficient of insensitiveness

$$\frac{N'' - N'}{N} = \frac{F (1 + q)}{2 m \cdot g + M \cdot g (1 + q)}$$

5. In case of a Hartnell governor,

$$F_B = F_S \times \frac{y}{2x}$$

$$\therefore \text{Coefficient of insensitiveness} = \frac{N'' - N'}{N} = \frac{F_B}{F_C} = \frac{F_S}{F_C} \times \frac{y}{2x} \quad \dots(xi)$$

**Example 18.30.** A Porter governor has equal arms 200 mm long pivoted on the axis of rotation. The mass of each ball is 3 kg and the mass on the sleeve is 15 kg. The ball path is 120 mm when the governor begins to lift and 160 mm at the maximum speed. Determine the range of speed.

If the friction at the sleeve is equivalent to a force of 10 N, find the coefficient of insensitiveness.

**Solution.** Given :  $BP = BD = 200 \text{ mm} = 0.2 \text{ m}$  ;  $m = 3 \text{ kg}$  ;  $M = 15 \text{ kg}$  ;  $r_1 = 120 \text{ mm} = 0.12 \text{ m}$  ;  $r_2 = 160 \text{ mm} = 0.16 \text{ m}$  ;  $F = 10 \text{ N}$

**Range of speed**

First of all, let us find the minimum and maximum speed of rotation.

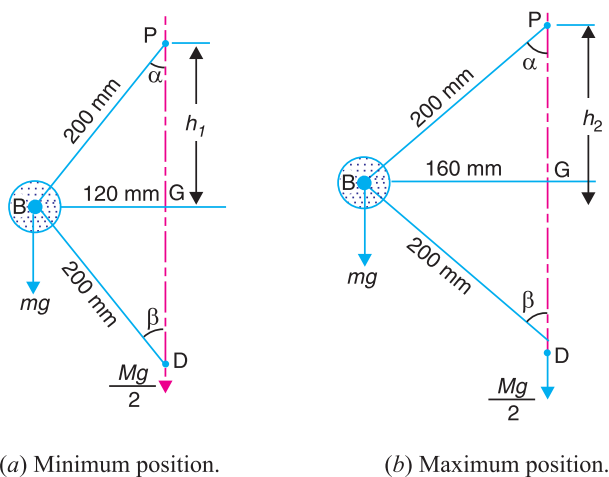

**Fig. 18.46**

The minimum and maximum position of the balls is shown in Fig 18.46 (a) and (b) respectively.

Let  $N_1$  = Minimum speed, and  $N_2$  = Maximum speed.

## 720 • Theory of Machines

From Fig. 18.46 (a),  $h_1 = \sqrt{(BP)^2 - (BG)^2} = \sqrt{(0.2)^2 - (0.12)^2} = 0.16 \text{ m}$

and from Fig. 18.46 (b),  $h_2 = \sqrt{(BP)^2 - (BG)^2} = \sqrt{(0.2)^2 - (0.16)^2} = 0.12 \text{ m}$

We know that  $(N_1)^2 = \frac{m + M}{m} \times \frac{895}{h_1} = \frac{3 + 15}{3} \times \frac{895}{0.16} = 33\,563$

$\therefore N_1 = 183.2 \text{ r.p.m.}$

Similarly  $(N_2)^2 = \frac{m + M}{m} \times \frac{895}{h_2} = \frac{3 + 15}{3} \times \frac{895}{0.12} = 44\,750$

$\therefore N_2 = 211.5 \text{ r.p.m.}$

We know that range of speed

$$= N_2 - N_1 = 211.5 - 183.2 = 28.3 \text{ r.p.m. Ans.}$$

### Coefficient of insensitiveness

We know that coefficient of insensitiveness,

$$\frac{N'' - N'}{N} = \frac{F}{(m + M)g} = \frac{10}{(3 + 15)9.81} = 0.0566 = 5.66\% \text{ Ans.}$$

**Example 18.31.** The following particulars refer to a Proell governor with open arms :

Length of all arms = 200 mm, distance of pivot of arms from the axis of rotation = 40 mm, length of extension of lower arms to which the ball is attached = 100 mm, mass of each ball = 6 kg and mass of the central load = 150 kg. If the radius of rotation of the balls is 180 mm when the arms are inclined at  $40^\circ$  to the axis of rotation, find :

1. the equilibrium speed for the above configuration, 2. the coefficient of insensitiveness if the friction of the governor mechanism is equivalent to a force of 20 N at the sleeve, and 3. the range of speed between which the governor is inoperative.

**Solution.** Given :  $PF = FD = 200 \text{ mm} = 0.2 \text{ m}$  ;  $DK = 40 \text{ mm} = 0.04 \text{ m}$  ;  $BF = 100 \text{ mm} = 0.1 \text{ m}$  ;  $m = 6 \text{ kg}$  ;  $M = 150 \text{ kg}$  ;  $r = JG = 180 \text{ mm} = 0.18 \text{ m}$  ;  $F = 20 \text{ N}$

### 1. Equilibrium speed

Let  $N =$  Equilibrium speed.

From the equilibrium position, as shown in Fig 18.47, we find that the height of the governor,

$$h = PH = PF \cos 40^\circ = 0.2 \times 0.766 = 0.1532 \text{ m}$$

and  $FH = PF \sin 40^\circ = 0.2 \times 0.643 = 0.1286 \text{ m}$

$$\therefore JF = JG - HG - FH = 0.18 - 0.04 - 0.1286 = 0.0114 \text{ m}$$

and  $BJ = \sqrt{(BF)^2 - (JF)^2} = \sqrt{(0.1)^2 - (0.0114)^2} = 0.0993 \text{ m}$

$$BM = BJ + JM = 0.0993 + 0.1532 = 0.2525 \text{ m}$$

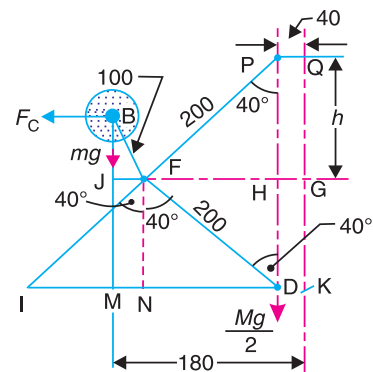

All dimensions in mm.

**Fig. 18.47**

... ( $\therefore JM = MD = PH$ )

$$IM = IN - MN = FH - JF = 0.1286 - 0.0114 = 0.1172 \text{ m}$$

$$ID = 2 \times IN = 2 \times FH = 2 \times 0.1286 = 0.2572 \text{ m}$$

We know that centrifugal force,

$$F_C = m \cdot \omega^2 \cdot r = 6 \left( \frac{2\pi N}{60} \right)^2 0.18 = 0.012 N^2$$

Now taking moments about  $I$ ,

$$F_C \times BM = m \cdot g \times IM + \frac{M \cdot g}{2} \times ID$$

$$0.012 N^2 \times 0.2525 = 6 \times 9.81 \times 0.1172 + \frac{150 \times 9.81}{2} \times 0.2572$$

or  $0.003 03 N^2 = 6.9 + 189.2 = 196.1$

$\therefore N^2 = 196.1/0.003 03 = 64 720$  or  $N = 254.4 \text{ r.p.m. Ans.}$

### Coefficient of insensitiveness

Let  $N'$  and  $N''$  = Minimum and maximum speed considering friction.

We know that centrifugal force at the minimum speed,

$$F_C' = m (\omega')^2 r = 6 \left( \frac{2\pi N'}{60} \right)^2 0.18 = 0.012 (N')^2$$

and centrifugal force at the maximum speed,

$$F_C'' = m (\omega'')^2 r = 6 \left( \frac{2\pi N''}{60} \right)^2 0.18 = 0.012 (N'')^2$$

Taking moments about  $I$ , when sleeve moves downwards,

$$F_C' \times BM = m \cdot g \times IM + \frac{M \cdot g - F}{2} \times ID$$

$$0.012 (N')^2 0.2525 = 6 \times 9.81 \times 0.1172 + \frac{150 \times 9.81 - 20}{2} \times 0.2572$$

$$0.003 03 (N')^2 = 6.9 + 186.7 = 193.6$$

$\therefore (N')^2 = 193.6/0.003 03 = 63 894$  or  $N' = 252.8 \text{ r.p.m.}$

Again taking moments about  $I$ , when the sleeve moves upwards,

$$F_C'' \times BM = m \cdot g \times IM + \frac{M \cdot g + F}{2} \times ID$$

$$0.012 (N'')^2 0.2525 = 6 \times 9.81 \times 0.1172 + \frac{150 \times 9.81 + 20}{2} \times 0.2572$$

$$0.003 03 (N'')^2 = 6.9 + 191.8 = 198.7$$

$\therefore (N'')^2 = 198.7/0.003 03 = 65 578$  or  $N'' = 256 \text{ r.p.m.}$

We know that coefficient of insensitiveness,

$$\frac{N'' - N'}{N} = \frac{256 - 252.8}{254.4} = 0.0126 \text{ or } 1.26\% \text{ Ans.}$$

### 3. Range of speed

We know that range of speed

$$= N'' - N' = 256 - 252.8 = 3.2 \text{ r.p.m. Ans.}$$

**Example 18.32.** A spring controlled governor is shown in Fig. 18.48. The central spindle does not move axially. The mass of the sleeve is 20 kg and the frictional resistance to its movement is equivalent to 20 N. The balls attached to the right angled bell crank levers have mass 4 kg each. The stiffness of the spring is 40 N/mm compression. The radius of rotation of the balls is 125 mm when the sleeve is in its lowest position, and the ball arms are vertical and the spring exerts a force of 600 N. Determine :

1. the speed at which the sleeve will begin to rise from its lowest position,
2. the range of speed when the sleeve is 12.5 mm above its lowest position, and
3. the coefficient of insensitiveness at higher speed.

**Solution.** Given :  $M = 20 \text{ kg}$  ;  $F = 20 \text{ N}$  ;  $m = 4 \text{ kg}$  ;  $s = 40 \text{ N/mm}$  ;  $r_1 = 125 \text{ mm} = 0.125 \text{ m}$  ;  $S_1 = 600 \text{ N}$

**1. Speed at which sleeve will begin to rise from its lowest position**

Let  $N_1 =$  Required speed.

The lowest position is shown in Fig. 18.49 (a).

We know that the centrifugal force at the lowest position,

$$F_{C1} = m (\omega_1)^2 r_1 = 4 \left( \frac{2\pi N_1}{60} \right)^2 0.125 = 0.0055 (N_1)^2$$

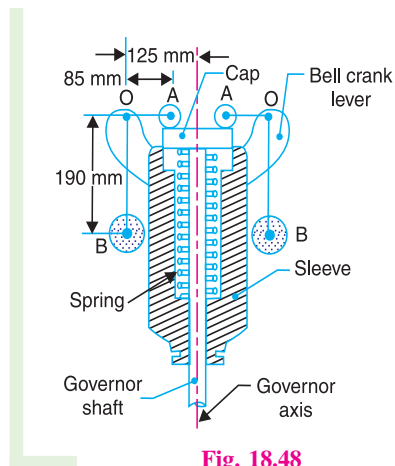

Fig. 18.48

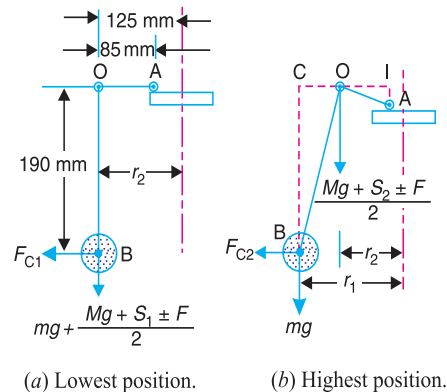

Fig. 18.49

Since the sleeve is about to rise, therefore frictional resistance is taken positive. Also the central spindle is stationary, therefore all the forces are transferred to both the pivots of the bell crank lever i.e.  $\frac{M \cdot g + S_1 + F}{2}$  at each pivot, as shown in Fig. 18.49 (a).

Since the pivot  $O$  moves vertically and the roller  $A$  moves horizontally, therefore  $A$  is the instantaneous centre of the bell crank lever.

Now taking moments about  $A$ ,

$$F_{C1} \times OB = \left( m \cdot g + \frac{M \cdot g + S_1 + F}{2} \right) OA$$

$$0.0055 (N_1)^2 \cdot 0.19 = \left( 4 \times 9.81 + \frac{20 \times 9.81 + 600 + 20}{2} \right) 0.085$$

$$0.00105 (N_1)^2 = 3.3 + 34.7 = 38 \quad \text{or} \quad (N_1)^2 = 38 / 0.00105 = 36190$$

$\therefore N_1 = 190 \text{ r.p.m. Ans.}$

**2. Range of speed**

The highest position is shown in Fig. 18.49 (b).

Let  $N_2$  = Maximum speed,  
 $h$  = Lift of the sleeve = 12.5 mm = 0.0125 m ... (Given)  
 $r_2$  = Maximum radius of rotation of the balls, and  
 $S_2$  = Maximum spring force.

We know that lift of the sleeve

$$h = (r_2 - r_1) \times \frac{y}{x} = (r_2 - r_1) \times \frac{OA}{OB} \quad \dots (\text{Here } x = OB, \text{ and } y = OA)$$

$$\therefore r_2 = r_1 + h \times OB/OA = 0.125 + 0.0125 \times 0.19/0.085 = 0.153 \text{ m}$$

We know that centrifugal force at the highest position,

$$F_{C2} = m (\omega_2)^2 r_2 = 4 \left( \frac{2\pi N_2}{60} \right)^2 0.153 = 0.0067 (N_2)^2$$

and  $S_2 - S_1 = h.s$  or  $S_2 = S_1 + h.s = 600 + 12.5 \times 40 = 1100 \text{ N}$

From Fig 18.49 (b), we find that

$$OI = \sqrt{(OA)^2 - (AI)^2} = \sqrt{(85)^2 - (12.5)^2} = 84 \text{ mm} = 0.084 \text{ m} \quad \dots (\because AI = h)$$

$$BC = \sqrt{(OB)^2 - (OC)^2} = \sqrt{(190)^2 - (153 - 125)^2} = 188 \text{ mm} = 0.188 \text{ m} \quad \dots (\because OC = r_2 - r_1)$$

and  $IC = OI + OC = 84 + (153 - 125) = 112 \text{ mm} = 0.112 \text{ m}$

Now taking moments about the instantaneous centre  $I$ ,

$$F_{C2} \times BC = m.g \times IC + \frac{M.g + S_2 \pm F}{2} \times OI$$

The  $\pm$  sign denotes that at the highest position, the sleeve may either rise or fall. Therefore

$$0.0067 (N_2)^2 \cdot 0.188 = 4 \times 9.81 \times 0.112 + \left( \frac{20 \times 9.81 + 1100 \pm 20}{2} \right) 0.084$$

$$0.00126 (N_2)^2 = 4.4 + 54.4 \pm 0.84 = 58.8 \pm 0.84$$

Taking - ve sign, when the sleeve is about to fall,

$$0.00126 (N_2)^2 = 58.8 - 0.84 = 57.96$$

$$(N_2)^2 = 57.96/0.00126 = 46000 \quad \text{or} \quad N_2 = 214.5 \text{ r.p.m.}$$

Taking + ve sign, when the sleeve is about to lift,

$$0.00126 (N_2')^2 = 58.8 + 0.84 = 59.64$$

$$(N_2')^2 = 59.64/0.00126 = 47333 \quad \text{or} \quad N_2' = 217.5 \text{ r.p.m.}$$

$\therefore$  Range of speed at the maximum radius

$$= N_2' - N_2 = 217.5 - 214.5 = 3 \text{ r.p.m. Ans.}$$

**724 • Theory of Machines**

**3. Coefficient of insensitiveness at higher speed**

We know that coefficient of insensitiveness

$$= \frac{2(N_2' - N_2)}{N_2' + N_2} = \frac{2(217.5 - 214.5)}{217.5 + 214.5} = 0.014 = 1.4\% \text{ Ans.}$$

**Example 18.33.** In a spring controlled governor, the curve of controlling force is a straight line. When balls are 400 mm apart, the controlling force is 1200 N and when 200 mm apart, the controlling force is 450 N. At what speed will the governor run when the balls are 250 mm apart? What initial tension on the spring would be required for isochronism and what would then be the speed? The mass of each ball is 9 kg.

**Solution.** Given : When balls are 400 mm apart, i.e. when the radius of rotation ( $r_2$ ) is 200 mm, the controlling force,

$$F_{C2} = 1200 \text{ N}$$

When balls are 200 mm apart i.e. when the radius of rotation ( $r_1$ ) is 100 mm, the controlling force,

$$F_{C1} = 450 \text{ N}$$

Mass of each ball,  $m = 9 \text{ kg}$

**Speed of the governor when the balls are 250 mm apart, i.e. when radius of rotation ( $r$ ) is 125 mm**

Let  $N =$  Required speed.

We know that for the stability of the spring controlled governors, the controlling force ( $F_C$ ) is expressed in the form

$$* F_C = a.r - b \quad \dots (i)$$

When  $r = r_1 = 100 \text{ mm} = 0.1 \text{ m}$ , then

$$450 = a \times 0.1 - b = 0.1 a - b \quad \dots (ii)$$

and when  $r = r_2 = 200 \text{ mm} = 0.2 \text{ m}$ , then

$$1200 = a \times 0.2 - b = 0.2 a - b \quad \dots (iii)$$

From equations (ii) and (iii), we find that

$$a = 7500, \quad \text{and} \quad b = 300$$

Now the equation (i) may be written as

$$F_C = 7500 r - 300 \quad \dots (iv)$$

Substituting  $r = 125 \text{ mm} = 0.125 \text{ m}$ , in equation (iv), we get

$$F_C = 7500 \times 0.125 - 300 = 637.5 \text{ N}$$

We know that  $F_C = m \cdot \omega^2 \cdot r = m \left( \frac{2\pi N}{60} \right)^2 r$

$$637.5 = 9 \left( \frac{2\pi N}{60} \right)^2 0.125 = 0.01234 N^2$$

$$\therefore N^2 = 637.5 / 0.01234 = 51661 \quad \text{or} \quad N = 227.3 \text{ r.p.m. Ans.}$$

\* We find that  $\frac{F_{C1}}{r_1} = \frac{450}{0.1} = 4500$  and  $\frac{F_{C2}}{r_2} = \frac{1200}{0.2} = 6000$ .

Since  $F_C/r$  increases as  $r$  increases, therefore for stability

$$F_C = a.r - b \quad (\text{See Art. 18.20})$$



**Initial tension on the spring for isochronism**

We have discussed in Art. 18.20 that for an isochronous governor, the controlling force line passed through the origin (*i.e.*  $b = 0$ ). The value of  $b$  is made zero by increasing the initial tension of the spring to 300 N.

∴ Initial tension on the spring for isochronism = 300 N **Ans.**

**Isochronous speed**

Let  $N'$  = Isochronous speed, and  
 $F_C'$  = Controlling force at the isochronous speed.

We know that for isochronism,

$$F_C' = a.r \quad \text{or} \quad m(\omega)^2 r = a.r \quad \text{or} \quad m(\omega)^2 = a$$

$$\therefore m \left( \frac{2\pi N'}{60} \right)^2 = a \quad \text{or} \quad 9 \times 0.011 (N')^2 = 7500$$

$$(N')^2 = 7500 / 0.099 = 75\,758 \quad \text{or} \quad N' = 275 \text{ r.p.m. } \mathbf{Ans.}$$

**Example 18.34.** The controlling force ( $F_C$ ) in newtons and the radius of rotation ( $r$ ) in metres for a spring controlled governor is given by the expression

$$F_C = 2800r - 76$$

The mass of the ball is 5 kg and the extreme radii of rotation of the balls are 100 mm and 175 mm. Find the maximum and minimum speeds of equilibrium. If the friction of the governor mechanism is equivalent to a force of 5 N at each ball, find the coefficient of insensitiveness of the governor at the extreme radii.

**Solution.** Given :  $m = 5 \text{ kg}$  ;  $r_1 = 100 \text{ mm} = 0.1 \text{ m}$  ;  $r_2 = 175 \text{ mm} = 0.175 \text{ m}$

**Maximum and minimum speeds of equilibrium**

Let  $N_2$  and  $N_1$  = Maximum and minimum speeds of equilibrium respectively.

The controlling force is given by the expression,

$$F_C = 2800r - 76$$

∴ Controlling force at the minimum radius of rotation (*i.e.* at  $r_1 = 0.1 \text{ m}$ ),

$$F_{C1} = 2800 \times 0.1 - 76 = 204 \text{ N}$$

and controlling force at the maximum radius of rotation (*i.e.* at  $r_2 = 0.175 \text{ m}$ ),

$$F_{C2} = 2800 \times 0.175 - 76 = 414 \text{ N}$$

We know that  $F_{C1} = m(\omega_1)^2 r_1 = m \left( \frac{2\pi N_1}{60} \right)^2 r_1$

or  $204 = 5 \left( \frac{2\pi N_1}{60} \right)^2 0.1 = 0.0055 (N_1)^2$

∴  $(N_1)^2 = 204 / 0.0055 = 37\,091 \quad \text{or} \quad N_1 = 192.6 \text{ r.p.m. } \mathbf{Ans.}$

Similarly  $F_{C2} = m(\omega_2)^2 r_2 = m \left( \frac{2\pi N_2}{60} \right)^2 r_2$

or  $414 = 5 \left( \frac{2\pi N_2}{60} \right)^2 0.175 = 0.0096 (N_2)^2$

∴  $(N_2)^2 = 414 / 0.0096 = 43\,125 \quad \text{or} \quad N_2 = 207.6 \text{ r.p.m. } \mathbf{Ans.}$

## 726 • Theory of Machines

### Coefficient of insensitiveness

Let  $N_1'$  and  $N_2'$  = Minimum and maximum speeds of the governor considering friction.

We know that frictional force at each ball

$$= 5 \text{ N} \quad \dots \text{ (Given)}$$

$$\therefore F_{C1} - F = m (\omega_1')^2 r_1 = m \left( \frac{2\pi N_1'}{60} \right)^2 r_1$$

$$204 - 5 = 5 \left( \frac{2\pi N_1'}{60} \right)^2 0.1 = 0.0055 (N_1')^2$$

$$\therefore (N_1')^2 = \frac{204 - 5}{0.0055} = 36\,182 \text{ or } N_1' = 190.2 \text{ r.p.m.}$$

Similarly  $F_{C2} + F = m (\omega_2')^2 r_2 = m \left( \frac{2\pi N_2'}{60} \right)^2 r_2$

$$414 + 5 = 5 \left( \frac{2\pi N_2'}{60} \right)^2 0.175 = 0.0096 (N_2')^2$$

$$\therefore (N_2')^2 = \frac{414 + 5}{0.0096} = 43\,646 \text{ or } N_2' = 209 \text{ r.p.m.}$$

We know that coefficient of insensitiveness

$$= \frac{2(N_2' - N_1')}{N_2' + N_1'} = \frac{2(209 - 190.2)}{209 + 190.2} = 0.094 \text{ or } 9.4\% \text{ Ans.}$$

## EXERCISES

- The length of the upper arm of a Watt governor is 400 mm and its inclination to the vertical is  $30^\circ$ . Find the percentage increase in speed, if the balls rise by 20 mm. **[Ans. 3%]**
- A Porter governor has two balls each of mass 3 kg and a central load of mass 15 kg. The arms are all 200 mm long, pivoted on the axis. If the maximum and minimum radii of rotation of the balls are 160 mm and 120 mm respectively, find the range of speed. **[Ans. 28.3 r.p.m.]**
- In a Porter governor, the mass of the central load is 18 kg and the mass of each ball is 2 kg. The top arms are 250 mm while the bottom arms are each 300 mm long. The friction of the sleeve is 14 N. If the top arms make  $45^\circ$  with the axis of rotation in the equilibrium position, find the range of speed of the governor in that position. **[Ans. 15 r.p.m.]**
- A loaded governor of the Porter type has equal arms and links each 250 mm long. The mass of each ball is 2 kg and the central mass is 12 kg. When the ball radius is 150 mm, the valve is fully open and when the radius is 185 mm, the valve is closed. Find the maximum speed and the range of speed. If the maximum speed is to be increased 20% by an addition of mass to the central load, find what additional mass is required. **[Ans. 193 r.p.m. ; 16 r.p.m.; 6.14 kg]**
- The arms of a Porter governor are 300 mm long. The upper arms are pivoted on the axis of rotation and the lower arms are attached to the sleeve at a distance of 35 mm from the axis of rotation. The load on the sleeve is 54 kg and the mass of each ball is 7 kg. Determine the equilibrium speed when the

radius of the balls is 225 mm. What will be the range of speed for this position, if the frictional resistances to the motion of the sleeve are equivalent to a force of 30 N?

[Ans. 174.3 r.p.m. ; 8.5 r.p.m.]

6. In a Porter governor, the upper and lower arms are each 250 mm long and are pivoted on the axis of rotation. The mass of each rotating ball is 3 kg and the mass of the sleeve is 20 kg. The sleeve is in its lowest position when the arms are inclined at  $30^\circ$  to the governor axis. The lift of the sleeve is 36 mm. Find the force of friction at the sleeve, if the speed at the moment it rises from the lowest position is equal to the speed at the moment it falls from the highest position. Also, find the range of speed of the governor. [Ans. 9.8 N ; 16 r.p.m.]
7. A Porter governor has links 150 mm long and are attached to pivots at a radial distance of 30 mm from the vertical axis of the governor. The mass of each ball is 1.75 kg and the mass of the sleeve is 25 kg. The governor sleeve begins to rise at 300 r.p.m. when the links are at  $30^\circ$  to the vertical. Assuming the friction force to be constant, find the minimum and maximum speed of rotation when the inclination of the links is  $45^\circ$  to the vertical. [Ans. 284 r.p.m. ; 347 r.p.m.]
8. A Proell governor has all the four arms of length 250 mm. The upper and lower ends of the arms are pivoted on the axis of rotation of the governor. The extension arms of the lower links are each 100 mm long and parallel to the axis when the radius of the ball path is 150 mm. The mass of each ball is 4.5 kg and the mass of the central load is 36 kg. Determine the equilibrium speed of the governor. [Ans. 164 r.p.m.]
9. A Proell governor has arms of 300 mm length. The upper arms are hinged on the axis of rotation, whereas the lower arms are pivoted at a distance of 35 mm from the axis of rotation. The extension of lower arms to which the balls are attached are 100 mm long. The mass of each ball is 8 kg and the mass on the sleeve is 60 kg. At the minimum radius of rotation of 200 mm, the extensions are parallel to the governor axis. Determine the equilibrium speed of the governor for the given configuration. What will be the equilibrium speed for the maximum radius of 250 mm? [Ans. 144.5 r.p.m. ; 158.2 r.p.m.]
10. A spring controlled governor of the Hartnell type with a central spring under compression has balls each of mass 2 kg. The ball and sleeve arms of the bell crank levers are respectively 100 mm and 60 mm long and are at right angles. In the lowest position of the governor sleeve, the radius of rotation of the balls is 80 mm and the ball arms are parallel to the governor axis. Find the initial load on the spring in order that the sleeve may begin to lift at 300 r.p.m. If the stiffness of the spring is 30 kN/m, what is the equilibrium speed corresponding to a sleeve lift of 10 mm? [Ans. 527 N ; 342 r.p.m.]
11. In a governor of the Hartnell type, the mass of each ball is 1.5 kg and the lengths of the vertical and horizontal arms of the bell crank lever are 100 mm and 50 mm respectively. The fulcrum of the bell crank lever is at a distance of 90 mm from the axis of rotation. The maximum and minimum radii of rotation of balls are 120 mm and 80 mm and the corresponding equilibrium speeds are 325 and 300 r.p.m. Find the stiffness of the spring and the equilibrium speed when the radius of rotation is 100 mm. [Ans. 18 kN/m, 315 r.p.m.]
12. A governor of the Hartnell type has equal balls of mass 3 kg, set initially at a radius of 200 mm. The arms of the bell crank lever are 110 mm vertically and 150 mm horizontally. Find : 1. the initial compressive force on the spring, if the speed for an initial ball radius of 200 mm is 240 r.p.m. ; and 2. the stiffness of the spring required to permit a sleeve movement of 4 mm on a fluctuation of 7.5 per cent in the engine speed. [Ans. 556 N ; 23.75 N/mm]
13. A spring controlled governor of the Hartnell type has the following data :  
Mass of the ball = 1.8 kg ; Mass of the sleeve = 6 kg ; Ball and sleeve arms of the bell crank lever = 150 mm and 120 mm respectively. The equilibrium speed and radius of rotation for the lowest position of the sleeve are 400 r.p.m. and 150 mm respectively. The sleeve lift is 10 mm and the change in speed for full sleeve lift is 5%. During an overhaul, the spring was compressed 2 mm more than the correct compression for the initial setting. Determine the stiffness of the spring and the new equilibrium speed for the lowest position of the sleeve. [Ans. 28.96 N/mm ; 472 r.p.m.]

728 • Theory of Machines

14. A spring controlled governor of the Hartnell type has two rotating balls of mass 1.35 kg each. The ball arm is 75 mm and the sleeve arm is 62.5 mm. In the mid position of the sleeve, the sleeve arm is horizontal and the balls rotate in a circle of 100 mm radius. The total sleeve movement is 30 mm. Due to maladjustment of the spring, it is found that the equilibrium speed at the topmost position of the sleeve is 420 r.p.m. and that corresponding to the lowest position is 435 r.p.m. Determine : 1. stiffness and initial compression of the spring, and 2. the required initial compression of the spring to give an equilibrium speed at the topmost position which is 12 r.p.m. more than at the lowest position. Neglect the moment due to mass of the balls.

[Ans. 6.3 N/mm, 87.54 mm ; 53.5 mm]

15. A Hartnell governor has two rotating balls, of mass 2.7 kg each. The ball radius is 125 mm in the mean position when the ball arms are vertical and the speed is 150 r.p.m. with the sleeve rising. The length of the ball arms is 140 mm and the length of the sleeve arms 90 mm. The stiffness of the spring is 7 kN/m and the total sleeve movement is 12 mm from the mean position. Allowing for a constant friction force of 14 N acting at the sleeve, determine the speed range of the governor in the lowest and highest sleeve positions. Neglect the obliquity of the ball arms.

[Ans. 10.7 r.p.m., 6.6 r.p.m.]

16. The spring controlled governor of the Hartung type has two rotating masses each of 2.5 kg and the limits of their radius of rotation are 100 mm and 125 mm. The each mass is directly controlled by a spring attached to it and to the inner casing of the governor as shown in Fig 18.26 (a). The stiffness of the spring is 8 kN/m and the force on each spring, when the masses are in their mid-position, is 320 N. In addition, there is an equivalent constant inward radial force of 80 N acting on each revolving mass in order to allow for the dead weight of the mechanism. Neglecting friction, find the range of speed of the governor.

[Ans. 51 r.p.m.]

17. In a spring controlled governor of the Hartung type, the lengths of the horizontal and vertical arms of the bell crank levers are 100 mm and 80 mm respectively. The fulcrum of the bell crank lever is at a distance of 120 mm from the axis of the governor. The each revolving mass is 9 kg. The stiffness of the spring is 25 kN/m. If the length of each spring is 120 mm when the radius of rotation is 70 mm and the equilibrium speed is 360 r.p.m., find the free length of the spring. If the radius of rotation increases to 120 mm, what will be the corresponding percentage increase in speed ?

[Ans 145.75 mm ; 10.83%]

[Hint. Free length of the spring = Length of the spring + compression of the spring]

18. The following particulars refer to a Wilson-Hartnell governor :  
 Mass of each ball = 4 kg ; minimum radius = 80 mm ; maximum radius = 90 mm ; minimum speed = 240 r.p.m.; maximum speed = 252 r.p.m.; length of the ball arm of each bell crank lever = 80 mm ; length of sleeve arm of each bell crank lever = 60 mm ; combined stiffness of the two ball springs = 750 N/m.

Find the required stiffness of the auxiliary spring, if the lever is pivoted at the mid-point.

[Ans. 6.786 kN/m]

19. A spring loaded governor of the Wilson-Hartnell type is shown in Fig 18.50. Two balls each of mass 4 kg are connected across by two springs A. The stiffness of each spring is 750 N/m and a free length of 100 mm. The length of ball arm of each bell crank lever is 80 mm and that of sleeve arm is 60 mm. The lever is pivoted at its mid-point. The speed of the governor is 240 r.p.m. in its mean position and the radius of rotation of the ball is 80 mm. If the lift of the sleeve is 7.5 mm for an increase of speed of 5%, find the required stiffness of the auxiliary spring B.

[Ans. 6.756 kN/m]

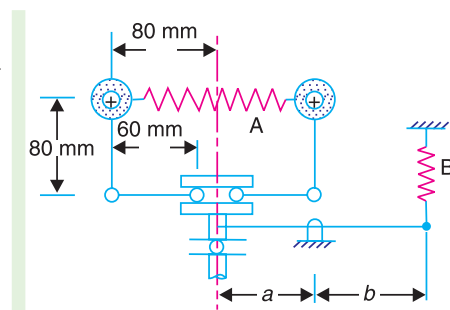

Fig. 18.50

20. A Porter governor has all four arms 200 mm long. The upper arms are pivoted on the axis of rotation and the lower arms are attached to a sleeve at a distance of 25 mm from the axis. Each ball has a mass of 2 kg and the mass of the load on the sleeve is 20 kg. If the radius of rotation of the balls at a speed of 250 r.p.m. is 100 mm, find the speed of the governor after the sleeve has lifted 50 mm. Also determine the effort and power of the governor. **[Ans. 275.6 r.p.m.; 22.4 N ; 1.12 N-m]**
21. A Porter governor has arms 250 mm each and four rotating flyballs of mass 0.8 kg each. The sleeve movement is restricted to  $\pm 20$  mm from the height when the mean speed is 100 r.p.m. Calculate the central dead load and sensitivity of the governor neglecting friction when the flyball exerts a centrifugal force of 9.81 N. Determine also the effort and power of the governor for 1 percent speed change. **[Ans. 11.76 N; 11.12; 0.196 N; 7.7 N-mm]**
22. The upper arms of a Porter governor are pivoted on the axis of rotation and the lower arms are pivoted to the sleeve at a distance of 30 mm from the axis of rotation. The length of each arm is 300 mm and the mass of each ball is 6 kg. If the equilibrium speed is 200 r.p.m. when the radius of rotation is 200 mm, find the required mass on the sleeve. If the friction is equivalent to a force of 40 N at the sleeve, find the coefficient of insensitiveness at 200 mm radius. **[Ans. 61.1 kg ; 6%]**
23. In a spring controlled governor, the radial force acting on the balls was 4500 N when the centre of balls was 200 mm from the axis and 7500 N when at 300 mm. Assuming that the force varies directly as the radius, find the radius of the ball path when the governor runs at 270 r.p.m. Also find what alteration in spring load is required in order to make the governor isochronous and the speed at which it would then run. The mass of each ball is 30 kg. **[Ans. 250 mm ; 1500 N ; 301.5 r.p.m.]**

### DO YOU KNOW ?

1. What is the function of a governor ? How does it differ from that of a flywheel ?
2. State the different types of governors. What is the difference between centrifugal and inertia type governors ? Why is the former preferred to the latter ?
3. Explain the term height of the governor. Derive an expression for the height in the case of a Watt governor. What are the limitations of a Watt governor ?
4. What are the effects of friction and of adding a central weight to the sleeve of a Watt governor ?
5. Discuss the controlling force and stability of a governor and show that the stability of a governor depends on the slope of the curve connecting the controlling force ( $F_C$ ) and radius of rotation ( $r$ ) and the value ( $F_C/r$ ).
6. What is stability of a governor ? Sketch the controlling force *versus* radius diagrams for a stable, unstable and isochronous governor. Derive the conditions for stability.
7. Explain clearly how would you determine from the controlling force curve whether a governor is stable, unstable or isochronous. Show also how the effect of friction may be indicated on the curve.
8. Define and explain the following terms relating to governors :  
1. Stability, 2. Sensitiveness, 3. Isochronism, and 4. Hunting.
9. Explain the terms and derive expressions for 'effort' and 'power' of a Porter governor.
10. Prove that the sensitiveness of a Proell governor is greater than that of a Porter governor.
11. Write short note on 'coefficient of insensitiveness' of governors.

### OBJECTIVE TYPE QUESTIONS

1. The height of a Watt's governor (in metres) is equal to  
(a)  $8.95/N^2$                       (b)  $89.5/N^2$                       (c)  $895/N^2$                       (d)  $8950/N^2$   
where  $N$  = Speed of the arm and ball about the spindle axis.

**730 • Theory of Machines**

2. The ratio of the height of a Porter governor (when the length of arms and links are equal) to the height of a Watt's governor is

(a)  $\frac{m}{m+M}$       (b)  $\frac{M}{m+M}$       (c)  $\frac{m+M}{m}$       (d)  $\frac{m+M}{M}$

where  $m$  = Mass of the ball, and

$M$  = Mass of the load on the sleeve.

3. When the sleeve of a Porter governor moves upwards, the governor speed  
 (a) increases      (b) decreases      (c) remains unaffected
4. A Hartnell governor is a  
 (a) pendulum type governor      (b) spring loaded governor  
 (c) dead weight governor      (d) inertia governor
5. Which of the following governor is used to drive a gramophone ?  
 (a) Watt governor      (b) Porter governor  
 (c) Pickering governor      (d) Hartnell governor
6. Which of the following is a spring controlled governor?  
 (a) Hartnell      (b) Hartung      (c) Pickering      (d) all of these
7. For two governors  $A$  and  $B$ , the lift of sleeve of governor  $A$  is more than that of governor  $B$ , for a given fractional change in speed. It indicates that  
 (a) governor  $A$  is more sensitive than governor  $B$   
 (b) governor  $B$  is more sensitive than governor  $A$   
 (c) both governors  $A$  and  $B$  are equally sensitive  
 (d) none of the above
8. The sensitiveness of a governor is given by

(a)  $\frac{\omega_{mean}}{\omega_2 - \omega_1}$       (b)  $\frac{\omega_2 - \omega_1}{\omega_{mean}}$       (c)  $\frac{\omega_2 - \omega_1}{2\omega_{mean}}$       (d) none of these

where  $\omega_1$  and  $\omega_2$  = Minimum and maximum angular speed, and

$\omega_{mean}$  = Mean angular speed.

9. In a Hartnell governor, if a spring of greater stiffness is used, then the governor will be  
 (a) more sensitive      (b) less sensitive      (c) isochronous
10. A governor is said to be hunting, if the speed of the engine  
 (a) remains constant at the mean speed  
 (b) is above the mean speed  
 (c) is below the mean speed  
 (d) fluctuates continuously above and below the mean speed.
11. A hunting governor is  
 (a) more stable      (b) less sensitive      (c) more sensitive      (d) none of these
12. Isochronism in a governor is desirable when  
 (a) the engine operates at low speeds  
 (b) the engine operates at high speeds  
 (c) the engine operates at variable speeds  
 (d) one speed is desired under one load

13. The power of a governor is equal to

(a)  $\frac{c^2}{1+2c} (m+M) h$

(b)  $\frac{2c^2}{1+2c} (m+M) h$

(c)  $\frac{3c^2}{1+2c} (m+M) h$

(d)  $\frac{4c^2}{1+2c} (m+M) h$

where  $c$  = Percentage increase in speed.

14. When the relation between the controlling force ( $F_C$ ) and radius of rotation ( $r$ ) for a spring controlled governor is  $F_C = a.r + b$ , then the governor will be

(a) stable                      (b) unstable                      (c) isochronous

15. For a governor, if  $F_C$  is the controlling force,  $r$  is the radius of rotation of the balls, the stability of the governor will be ensured when

(a)  $\frac{d F_C}{d r} > \frac{F_C}{r}$

(b)  $\frac{d F_C}{d r} < \frac{F_C}{r}$

(c)  $\frac{d F_C}{d r} = 0$

(d) none of these

## ANSWERS

1. (c)

2. (c)

3. (a)

4. (b)

5. (c)

6. (d)

7. (a)

8. (b)

9. (b)

10. (d)

11. (c)

12. (d)

13. (d)

14. (b)

15. (a)