



15

Inertia Forces in Reciprocating Parts

Features

1. Introduction.
2. Resultant Effect of a System of Forces Acting on a Rigid Body.
3. D'Alembert's Principle.
4. Velocity and Acceleration of the Reciprocating Parts in Engines.
5. Klien's Construction.
6. Ritterhaus's Construction.
7. Bennett's Construction.
8. Approximate Analytical Method for Velocity and Acceleration of the Piston.
9. Angular Velocity and Acceleration of the Connecting Rod.
10. Forces on the Reciprocating Parts of an Engine Neglecting Weight of the Connecting Rod.
11. Equivalent Dynamical System.
12. Determination of Equivalent Dynamical System of Two Masses by Graphical Method.
13. Correction Couple to be Applied to Make the Two Mass Systems Dynamically Equivalent.
14. Inertia Forces in a Reciprocating Engine Considering the Weight of Connecting Rod.
15. Analytical Method for Inertia Torque.

15.1. Introduction

The inertia force is an imaginary force, which when acts upon a rigid body, brings it in an equilibrium position. It is numerically equal to the accelerating force in magnitude, but *opposite* in direction. Mathematically,

$$\text{Inertia force} = - \text{Accelerating force} = - m.a$$

where

$m =$ Mass of the body, and

$a =$ Linear acceleration of the centre of gravity of the body.

Similarly, the inertia torque is an imaginary torque, which when applied upon the rigid body, brings it in equilibrium position. It is equal to the accelerating couple in magnitude but *opposite* in direction.

15.2. Resultant Effect of a System of Forces Acting on a Rigid Body

Consider a rigid body acted upon by a system of forces. These forces may be reduced to a single resultant force

F whose line of action is at a distance h from the centre of gravity G . Now let us assume two equal and opposite forces (of magnitude F) acting through G , and parallel to the resultant force, without influencing the effect of the resultant force F , as shown in Fig. 15.1.

A little consideration will show that the body is now subjected to a couple (equal to $F \times h$) and a force, equal and parallel to the resultant force F passing through G . The force F through G causes linear acceleration of the c.g. and the moment of the couple ($F \times h$) causes angular acceleration of the body about an axis passing through G and perpendicular to the point in which the couple acts.

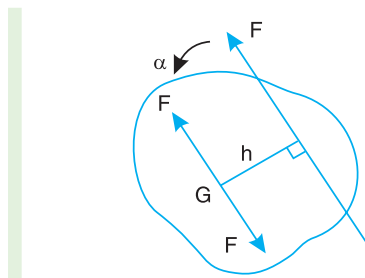

Fig. 15.1. Resultant effect of a system of forces acting on a rigid body.

- Let
- α = Angular acceleration of the rigid body due to couple,
 - h = Perpendicular distance between the force and centre of gravity of the body,
 - m = Mass of the body,
 - k = Least radius of gyration about an axis through G , and
 - I = Moment of inertia of the body about an axis passing through its centre of gravity and perpendicular to the point in which the couple acts
 $= m.k^2$

We know that

Force, $F = \text{Mass} \times \text{Acceleration} = m.a$...(i)

and $F.h = m.k^2.\alpha = I.\alpha$...($\because I = m.k^2$)...(ii)

From equations (i) and (ii), we can find the values of a and α , if the values of F , m , k , and h are known.

15.3. D'Alembert's Principle

Consider a rigid body acted upon by a system of forces. The system may be reduced to a single resultant force acting on the body whose magnitude is given by the product of the mass of the body and the linear acceleration of the centre of mass of the body. According to Newton's second law of motion,

$$F = m.a$$
 ...(i)

where

F = Resultant force acting on the body,

m = Mass of the body, and

a = Linear acceleration of the centre of mass of the body.

The equation (i) may also be written as:

$$F - m.a = 0$$
 ...(ii)

A little consideration will show, that if the quantity $-m.a$ be treated as a force, equal, opposite

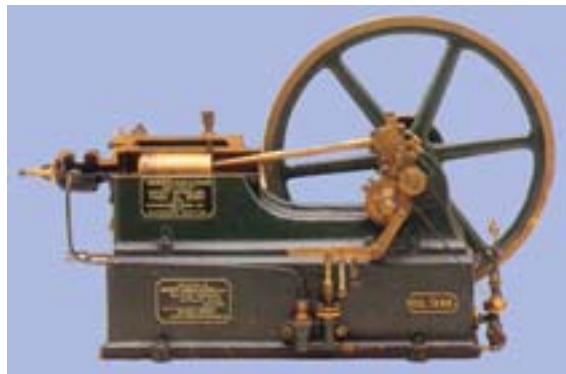

The above picture shows the reciprocating parts of a 19th century oil engine.

516 • Theory of Machines

and with the same line of action as the resultant force F , and include this force with the system of forces of which F is the resultant, then the complete system of forces will be in equilibrium. This principle is known as **D'Alembert's principle**. The equal and opposite force $-m.a$ is known as **reversed effective force** or the **inertia force** (briefly written as F_I). The equation (ii) may be written as

$$F + F_I = 0 \quad \dots(iii)$$

Thus, D'Alembert's principle states that **the resultant force acting on a body together with the reversed effective force (or inertia force), are in equilibrium.**

This principle is used to reduce a dynamic problem into an equivalent static problem.

15.4. Velocity and Acceleration of the Reciprocating Parts in Engines

The velocity and acceleration of the reciprocating parts of the steam engine or internal combustion engine (briefly called as I.C. engine) may be determined by graphical method or analytical method. The velocity and acceleration, by graphical method, may be determined by one of the following constructions:

1. Klien's construction, 2. Ritterhaus's construction, and 3. Bennett's construction.

We shall now discuss these constructions, in detail, in the following pages.

15.5. Klien's Construction

Let OC be the crank and PC the connecting rod of a reciprocating steam engine, as shown in Fig. 15.2 (a). Let the crank makes an angle θ with the line of stroke PO and rotates with uniform angular velocity ω rad/s in a clockwise direction. The Klien's velocity and acceleration diagrams are drawn as discussed below:

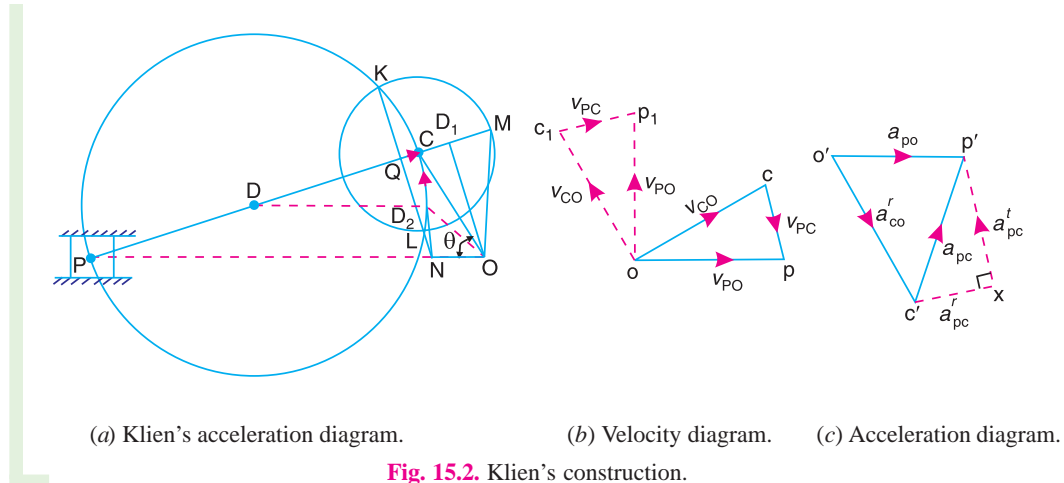

Fig. 15.2. Klien's construction.

Klien's velocity diagram

First of all, draw OM perpendicular to OP ; such that it intersects the line PC produced at M . The triangle OCM is known as **Klien's velocity diagram**. In this triangle OCM ,

OM may be regarded as a line perpendicular to PO ,

CM may be regarded as a line parallel to PC , and $\dots(\because$ It is the same line.)

CO may be regarded as a line parallel to CO .

We have already discussed that the velocity diagram for given configuration is a triangle ocp

as shown in Fig. 15.2 (b). If this triangle is revolved through 90°, it will be a triangle oc_1p_1 , in which oc_1 represents v_{CO} (i.e. velocity of C with respect to O or velocity of crank pin C) and is parallel to OC,

op_1 represents v_{PO} (i.e. velocity of P with respect to O or velocity of cross-head or piston P) and is perpendicular to OP, and

c_1p_1 represents v_{PC} (i.e. velocity of P with respect to C) and is parallel to CP.

A little consideration will show, that the triangles oc_1p_1 and OCM are similar. Therefore,

$$\frac{oc_1}{OC} = \frac{op_1}{OM} = \frac{c_1p_1}{CM} = \omega \text{ (a constant)}$$

or
$$\frac{v_{CO}}{OC} = \frac{v_{PO}}{OM} = \frac{v_{PC}}{CM} = \omega$$

∴
$$v_{CO} = \omega \times OC ; v_{PO} = \omega \times OM, \text{ and } v_{PC} = \omega \times CM$$

Thus, we see that by drawing the Klien's velocity diagram, the velocities of various points may be obtained without drawing a separate velocity diagram.

Klien's acceleration diagram

The Klien's acceleration diagram is drawn as discussed below:

1. First of all, draw a circle with C as centre and CM as radius.
2. Draw another circle with PC as diameter. Let this circle intersect the previous circle at K and L.
3. Join KL and produce it to intersect PO at N. Let KL intersect PC at Q. This forms the quadrilateral CQNO, which is known as **Klien's acceleration diagram**.



We have already discussed that the acceleration diagram for the given configuration is as shown in Fig. 15.2 (c). We know that

(i) $o'c'$ represents a_{CO}^r (i.e. radial component of the acceleration of crank pin C with respect to O) and is parallel to CO;

(ii) $c'x$ represents a_{PC}^r (i.e. radial component of the acceleration of crosshead or piston P with respect to crank pin C) and is parallel to CP or CQ;

(iii) xp' represents a_{PC}^t (i.e. tangential component of the acceleration of P with respect to C) and is parallel to QN (because QN is perpendicular to CQ); and

(iv) $o'p'$ represents a_{PO} (i.e. acceleration of P with respect to O or the acceleration of piston P) and is parallel to PO or NO.

A little consideration will show that the quadrilateral $o'c'x p'$ [Fig. 15.2 (c)] is similar to quadrilateral CQNO [Fig. 15.2 (a)]. Therefore,

$$\frac{o'c'}{OC} = \frac{c'x}{CQ} = \frac{xp'}{QN} = \frac{o'p'}{NO} = \omega^2 \text{ (a constant)}$$

518 • Theory of Machines

or
$$\frac{a_{CO}^r}{OC} = \frac{a_{PC}^r}{CQ} = \frac{a_{PC}^t}{QN} = \frac{a_{PO}}{NO} = \omega^2$$

$$\therefore a_{CO}^r = \omega^2 \times OC; a_{PC}^r = \omega^2 \times CQ$$

$$a_{PC}^t = \omega^2 \times QN; \text{ and } a_{PO} = \omega^2 \times NO$$

Thus we see that by drawing the Klien's acceleration diagram, the acceleration of various points may be obtained without drawing the separate acceleration diagram.

Notes: 1. The acceleration of piston P with respect to crank pin C (i.e. a_{PC}) may be obtained from:

$$\frac{c'p'}{CN} = \omega^2 \quad \text{or} \quad \frac{a_{PC}}{CN} = \omega^2$$

$$\therefore a_{PC} = \omega^2 \times CN$$

2. To find the velocity of any point D on the connecting rod PC , divide CM at D_1 in the same ratio as D divides CP . In other words,

$$\frac{CD_1}{CM} = \frac{CD}{CP}$$

$$\therefore \text{Velocity of } D, v_D = \omega \times OD_1$$

3. To find the acceleration of any point D on the connecting rod PC , draw a line from a point D parallel to PO which intersects CN at D_2 .

$$\therefore \text{Acceleration of } D, a_D = \omega^2 \times OD_2$$

4. If the crank position is such that the point N lies on the right of O instead of to the left as shown in Fig. 15.2 (a), then the acceleration of the piston is negative. In other words, the piston is under going retardation.

5. The acceleration of the piston P is zero and its velocity is maximum, when N coincides with O . There is no simple graphical method of finding the corresponding crank position, but it can be shown that for N and O to coincide, the angle between the crank and the connecting rod must be slightly less than 90° . For most practical purposes, it is assumed that the acceleration of piston P is zero, when the crank OC and connecting rod PC are at right angles to each other.

15.6. Ritterhaus's Construction

Let OC be the crank and PC the connecting rod of a reciprocating steam engine, as shown in Fig. 15.3. Let the crank makes an angle θ with the line of stroke PO and rotates with uniform angular velocity ω rad/s in a clockwise direction. The Ritterhaus's velocity and acceleration diagrams are drawn as discussed below:

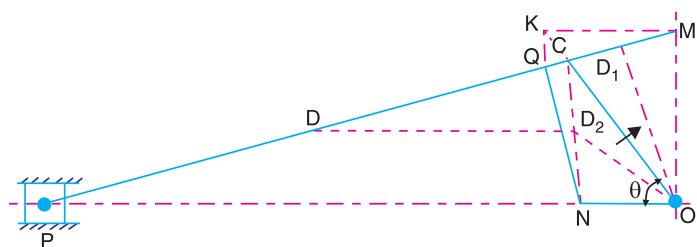

Fig. 15.3. Ritterhaus's construction.

Ritterhaus's velocity diagram

Draw OM perpendicular to the line of stroke PO , such that it intersects the line PC produced at M . The triangle OCM is known as **Ritterhaus's velocity diagram**. It is similar to Klien's velocity diagram.

∴ Velocity of C with respect to O or the velocity of crank pin C ,

$$v_{CO} = v_C = \omega \times OC$$

Velocity of P with respect to O or the velocity of crosshead or piston P ,

$$v_{PO} = v_P = \omega \times OM$$

and velocity of P with respect to C , $v_{PC} = \omega \times CM$

Ritterhaus's acceleration diagram

The Ritterhaus's acceleration diagram is drawn as discussed below:

1. From point M , draw MK parallel to the line of stroke PO , to intersect OC produced at K .
2. Draw KQ parallel to MO . From Q draw QN perpendicular to PC .
3. The quadrilateral $CQNO$ is known as **Ritterhaus's acceleration diagram**. This is similar to Klien's acceleration diagram.

∴ Radial component of the acceleration of C with respect to O or the acceleration of crank pin C ,

$$a_{CO}^r = a_C = \omega^2 \times OC$$

Radial component of the acceleration of the crosshead or piston P with respect to crank pin C ,

$$a_{PC}^r = \omega^2 \times CQ$$

Tangential component of the acceleration of P with respect to C ,

$$a_{PC}^t = \omega^2 \times QN$$

and acceleration of P with respect to O or the acceleration of piston P ,

$$a_{PO} = a_P = \omega^2 \times NO$$

Notes : 1. The acceleration of piston P with respect to crank pin C is given by

$$a_{PC} = \omega^2 \times CN$$

2. To find the velocity of any point D on the connecting rod PC , divide CM at D_1 in the same ratio as D divides CP . In other words,

$$\frac{CD_1}{CM} = \frac{CD}{CP}$$

∴ Velocity of D $v_D = \omega \times OD_1$

3. To find the acceleration of any point D on the connecting rod PC , draw DD_2 parallel to the line of stroke PO , which intersects CN at D_2 . The acceleration of D is given by

$$a_D = \omega^2 \times OD_2$$

15.7. Bennett's Construction

Let OC be the crank and PC the connecting rod of reciprocating steam engine, as shown in Fig. 15.4. Let the crank makes an angle θ with the line of stroke PO and rotates with uniform angular velocity ω rad/s in the clockwise direction. The Bennett's velocity and acceleration diagrams are drawn as discussed below:

Bennett's velocity diagram

When the crank OC is at right angle to the line of stroke, it occupies the position OC_1 and the crosshead P moves to the position P_1 , as shown in Fig. 15.4. Now, produce PC to intersect OC_1 at M . The triangle OCM is known as **Bennett's velocity diagram**. It is similar to Klien's velocity diagram.

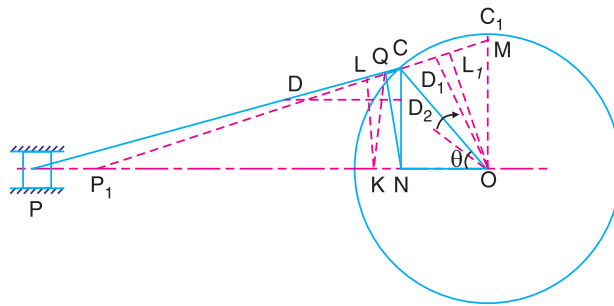

Fig. 15.4. Bennett's construction.

∴ Velocity of C with respect to O or the velocity of crank pin C ,

$$v_{CO} = v_C = \omega \times OC$$

Velocity of P with respect to O or the velocity of crosshead or piston P ,

$$v_{PO} = v_P = \omega \times OM$$

and velocity of P with respect to C , $v_{PC} = \omega \times CM$

Bennett's acceleration diagram

The Bennett's acceleration diagram is drawn as discussed below:

1. From O , draw OL_1 perpendicular to P_1C_1 (i.e. position of connecting rod PC when crank is at right angle). Mark the position of point L on the connecting rod PC such that $CL = C_1L_1$.

2. From L , draw LK perpendicular to PC and from point K draw KQ perpendicular to the line of stroke PO . From point C , draw CN perpendicular to the line of stroke PO . Join NQ . A little consideration will show that NQ is perpendicular to PC .

3. The quadrilateral $CQNO$ is known as **Bennett's acceleration diagram**. It is similar to Klien's acceleration diagram.

∴ Radial component of the acceleration of C with respect to O or the acceleration of the crank pin C ,

$$a_{CO}^r = a_C = \omega^2 \times OC$$

Radial component of the acceleration of the crosshead or piston P with respect to crank pin C ,

$$a_{PC}^r = \omega^2 \times CQ$$

Tangential component of the acceleration of P with respect to C ,

$$a_{PC}^t = \omega^2 \times QN$$

and acceleration of P with respect to O or the acceleration of piston P ,

$$a_{PO} = a_P = \omega^2 \times NO$$

Notes : 1. The acceleration of piston P with respect to crank pin C is given by

$$a_{PC} = \omega^2 \times CN$$

2. The velocity and acceleration of any point D on the connecting rod PC may be obtained in the similar way, as discussed in the previous articles, i.e.

$$\text{Velocity of } D, v_D = \omega \times OD_1$$

and Acceleration of D , $a_D = \omega^2 \times OD_2$

Example 15.1. The crank and connecting rod of a reciprocating engine are 200 mm and 700 mm respectively. The crank is rotating in clockwise direction at 120 rad/s. Find with the help of Klein's construction: **1.** Velocity and acceleration of the piston, **2.** Velocity and acceleration of the mid point of the connecting rod, and **3.** Angular velocity and angular acceleration of the connecting rod, at the instant when the crank is at 30° to I.D.C. (inner dead centre).

Solution. Given: $OC = 200 \text{ mm} = 0.2 \text{ m}$; $PC = 700 \text{ mm} = 0.7 \text{ m}$; $\omega = 120 \text{ rad/s}$

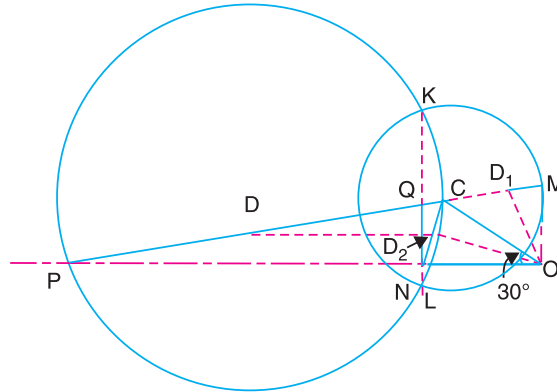

Fig. 15.5

The Klein's velocity diagram OCM and Klein's acceleration diagram $CQNO$ as shown in Fig. 15.5 is drawn to some suitable scale, in the similar way as discussed in Art. 15.5. By measurement, we find that

$OM = 127 \text{ mm} = 0.127 \text{ m}$; $CM = 173 \text{ mm} = 0.173 \text{ m}$; $QN = 93 \text{ mm} = 0.093 \text{ m}$; $NO = 200 \text{ mm} = 0.2 \text{ m}$

1. Velocity and acceleration of the piston

We know that the velocity of the piston P ,

$$v_p = \omega \times OM = 120 \times 0.127 = 15.24 \text{ m/s} \quad \text{Ans.}$$

and acceleration of the piston P ,

$$a_p = \omega^2 \times NO = (120)^2 \times 0.2 = 2880 \text{ m/s}^2 \quad \text{Ans.}$$

2. Velocity and acceleration of the mid-point of the connecting rod

In order to find the velocity of the mid-point D of the connecting rod, divide CM at D_1 in the same ratio as D divides CP . Since D is the mid-point of CP , therefore D_1 is the mid-point of CM , i.e. $CD_1 = D_1M$. Join OD_1 . By measurement,

$$OD_1 = 140 \text{ mm} = 0.14 \text{ m}$$

$$\therefore \text{Velocity of } D, v_D = \omega \times OD_1 = 120 \times 0.14 = 16.8 \text{ m/s} \quad \text{Ans.}$$

In order to find the acceleration of the mid-point of the connecting rod, draw a line DD_2 parallel to the line of stroke PO which intersects CN at D_2 . By measurement,

$$OD_2 = 193 \text{ mm} = 0.193 \text{ m}$$

\therefore Acceleration of D ,

$$a_D = \omega^2 \times OD_2 = (120)^2 \times 0.193 = 2779.2 \text{ m/s}^2 \quad \text{Ans.}$$

3. Angular velocity and angular acceleration of the connecting rod

We know that the velocity of the connecting rod PC (i.e. velocity of P with respect to C),

$$v_{PC} = \omega \times CM = 120 \times 0.173 = 20.76 \text{ m/s}$$

522 • Theory of Machines

∴ Angular acceleration of the connecting rod PC ,

$$\omega_{PC} = \frac{v_{PC}}{PC} = \frac{20.76}{0.7} = 29.66 \text{ rad/s Ans.}$$

We know that the tangential component of the acceleration of P with respect to C ,

$$a_{PC}^t = \omega^2 \times QN = (120)^2 \times 0.093 = 1339.2 \text{ m/s}^2$$

∴ Angular acceleration of the connecting rod PC ,

$$\alpha_{PC} = \frac{a_{PC}^t}{PC} = \frac{1339.2}{0.7} = 1913.14 \text{ rad/s}^2 \text{ Ans.}$$

Example 15.2. In a slider crank mechanism, the length of the crank and connecting rod are 150 mm and 600 mm respectively. The crank position is 60° from inner dead centre. The crank shaft speed is 450 r.p.m. clockwise. Using Ritterhaus's construction, determine **1.** Velocity and acceleration of the slider, **2.** Velocity and acceleration of point D on the connecting rod which is 150 mm from crank pin C , and **3.** angular velocity and angular acceleration of the connecting rod.

Solution. Given : $OC = 150 \text{ mm} = 0.15 \text{ m}$; $PC = 600 \text{ mm} = 0.6 \text{ m}$; $CD = 150 \text{ mm} = 0.15 \text{ m}$; $N = 450 \text{ r.p.m.}$ or $\omega = 2\pi \times 450/60 = 47.13 \text{ rad/s}$

The Ritterhaus's velocity diagram OCM and acceleration diagram $CQNO$, as shown in Fig. 15.6, is drawn to some suitable scale in the similar way as discussed in Art. 15.6. By measurement, we find that

$OM = 145 \text{ mm} = 0.145 \text{ m}$; $CM = 78 \text{ mm} = 0.078 \text{ m}$; $QN = 130 \text{ mm} = 0.13 \text{ m}$; and $NO = 56 \text{ mm} = 0.056 \text{ m}$

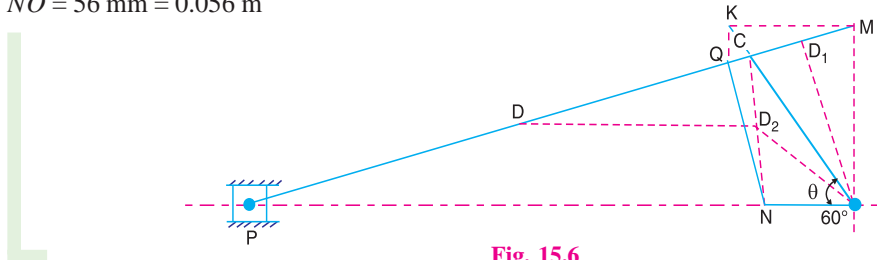

Fig. 15.6

1. Velocity and acceleration of the slider

We know that the velocity of the slider P ,

$$v_P = \omega \times OM = 47.13 \times 0.145 = 6.834 \text{ m/s Ans.}$$

and acceleration of the slider P ,

$$a_P = \omega^2 \times NO = (47.13)^2 \times 0.056 = 124.4 \text{ m/s}^2 \text{ Ans.}$$

2. Velocity and acceleration of point D on the connecting rod

In order to find the velocity of point D on the connecting rod, divide CM at D_1 in the same ratio as D divides CP . In other words,

$$\frac{CD_1}{CM} = \frac{CD}{CP} \quad \text{or} \quad CD_1 = \frac{CD}{CP} \times CM = \frac{150}{600} \times 78 = 19.5 \text{ mm}$$

Join OD_1 . By measurement, $OD_1 = 145 \text{ mm} = 0.145 \text{ m}$

∴ Velocity of point D ,

$$v_D = \omega \times OD_1 = 47.13 \times 0.145 = 6.834 \text{ m/s Ans.}$$

In order to find the acceleration of point D on the connecting rod, draw DD_2 parallel to the line of stroke PO . Join OD_2 . By measurement, we find that $OD_2 = 120 \text{ mm} = 0.12 \text{ m}$.

∴ Acceleration of point D ,

$$a_D = \omega^2 \times OD_2 = (47.13)^2 \times 0.12 = 266.55 \text{ m/s}^2 \text{ Ans.}$$

3. Angular velocity and angular acceleration of the connecting rod

We know that the velocity of the connecting rod PC (or the velocity of point P with respect to C),

$$v_{PC} = \omega \times CM = 47.13 \times 0.078 = 3.676 \text{ m/s}$$

∴ Angular velocity of the connecting rod,

$$\omega_{PC} = \frac{v_{PC}}{PC} = \frac{3.676}{0.6} = 6.127 \text{ rad/s Ans.}$$

We know that the tangential component of the acceleration of P with respect to C ,

$$a_{PC}^t = \omega^2 \times QN = (47.13)^2 \times 0.13 = 288.76 \text{ m/s}^2$$

∴ Angular acceleration of the connecting rod PC ,

$$\alpha_{PC} = \frac{a_{PC}^t}{PC} = \frac{288.76}{0.6} = 481.27 \text{ rad/s}^2 \text{ Ans.}$$

15.8. Approximate Analytical Method for Velocity and Acceleration of the Piston

Consider the motion of a crank and connecting rod of a reciprocating steam engine as shown in Fig. 15.7. Let OC be the crank and PC the connecting rod. Let the crank rotates with angular velocity of ω rad/s and the crank turns through an angle θ from the inner dead centre (briefly written as I.D.C). Let x be the displacement of a reciprocating body P from I.D.C. after time t seconds, during which the crank has turned through an angle θ .

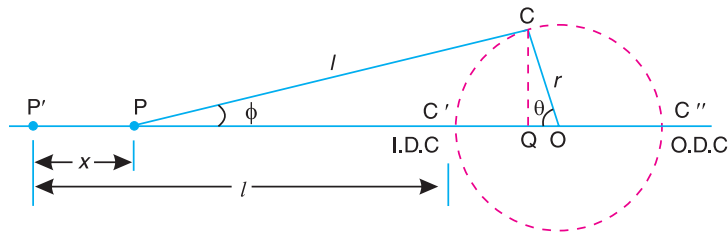

Fig. 15.7. Motion of a crank and connecting rod of a reciprocating steam engine.

- Let
- l = Length of connecting rod between the centres,
 - r = Radius of crank or crank pin circle,
 - ϕ = Inclination of connecting rod to the line of stroke PO , and
 - n = Ratio of length of connecting rod to the radius of crank = l/r .

Velocity of the piston

From the geometry of Fig. 15.7,

$$\begin{aligned} x = P'P = OP' - OP &= (P'C' + C'O) - (PQ + QO) \\ &= (l + r) - (l \cos \phi + r \cos \theta) \end{aligned} \quad \left[\begin{array}{l} \because PQ = l \cos \phi, \\ \text{and } QO = r \cos \theta \end{array} \right]$$

524 • Theory of Machines

$$\begin{aligned}
 &= r(1 - \cos \theta) + l(1 - \cos \phi) = r \left[(1 - \cos \theta) + \frac{l}{r}(1 - \cos \phi) \right] \\
 &= r [(1 - \cos \theta) + n(1 - \cos \phi)] \quad \dots(i)
 \end{aligned}$$

From triangles CPQ and CQO ,

$$CQ = l \sin \phi = r \sin \theta \text{ or } l/r = \sin \theta / \sin \phi$$

$$\therefore n = \sin \theta / \sin \phi \text{ or } \sin \phi = \sin \theta / n \quad \dots(ii)$$

We know that, $\cos \phi = (1 - \sin^2 \phi)^{\frac{1}{2}} = \left(1 - \frac{\sin^2 \theta}{n^2}\right)^{\frac{1}{2}}$

Expanding the above expression by binomial theorem, we get

$$\cos \phi = 1 - \frac{1}{2} \times \frac{\sin^2 \theta}{n^2} + \dots \quad \dots(\text{Neglecting higher terms})$$

or $1 - \cos \phi = \frac{\sin^2 \theta}{2n^2} \quad \dots(iii)$

Substituting the value of $(1 - \cos \phi)$ in equation (i), we have

$$x = r \left[(1 - \cos \theta) + n \times \frac{\sin^2 \theta}{2n^2} \right] = r \left[(1 - \cos \theta) + \frac{\sin^2 \theta}{2n} \right] \quad \dots(iv)$$

Differentiating equation (iv) with respect to θ ,

$$\frac{dx}{d\theta} = r \left[\sin \theta + \frac{1}{2n} \times 2 \sin \theta \cos \theta \right] = r \left(\sin \theta + \frac{\sin 2\theta}{2n} \right) \quad \dots(v)$$

($\because 2 \sin \theta \cos \theta = \sin 2\theta$)

\therefore Velocity of P with respect to O or velocity of the piston P ,

$$v_{PO} = v_P = \frac{dx}{dt} = \frac{dx}{d\theta} \times \frac{d\theta}{dt} = \frac{dx}{d\theta} \times \omega$$

$\dots(\because \text{Ratio of change of angular velocity} = d\theta/dt = \omega)$

Substituting the value of $dx/d\theta$ from equation (v), we have

$$v_{PO} = v_P = \omega r \left(\sin \theta + \frac{\sin 2\theta}{2n} \right) \quad \dots(vi)$$

Note: We know that by Klien's construction,

$$v_P = \omega \times OM$$

Comparing this equation with equation (vi), we find that

$$OM = r \left(\sin \theta + \frac{\sin 2\theta}{2n} \right)$$

Acceleration of the piston

Since the acceleration is the rate of change of velocity, therefore acceleration of the piston P ,

$$a_P = \frac{dv_P}{dt} = \frac{dv_P}{d\theta} \times \frac{d\theta}{dt} = \frac{dv_P}{d\theta} \times \omega$$

Differentiating equation (vi) with respect to θ ,

$$\frac{dv_p}{d\theta} = \omega.r \left[\cos \theta + \frac{\cos 2\theta \times 2}{2n} \right] = \omega.r \left[\cos \theta + \frac{\cos 2\theta}{n} \right]$$

Substituting the value of $\frac{dv_p}{d\theta}$ in the above equation, we have

$$a_p = \omega.r \left[\cos \theta + \frac{\cos 2\theta}{n} \right] \times \omega = \omega^2.r \left[\cos \theta + \frac{\cos 2\theta}{n} \right] \quad \dots(vii)$$

Notes: 1. When crank is at the inner dead centre (I.D.C.), then $\theta = 0^\circ$.

$$\therefore a_p = \omega^2.r \left[\cos 0^\circ + \frac{\cos 0^\circ}{n} \right] = \omega^2.r \left(1 + \frac{1}{n} \right)$$

2. When the crank is at the outer dead centre (O.D.C.), then $\theta = 180^\circ$.

$$\therefore a_p = \omega^2.r \left[\cos 180^\circ + \frac{\cos 2 \times 180^\circ}{n} \right] = \omega^2.r \left(-1 + \frac{1}{n} \right)$$

As the direction of motion is reversed at the outer dead centre therefore changing the sign of the above expression,

$$a_p = \omega^2.r \left[1 - \frac{1}{n} \right]$$



Above picture shows a diesel engine. Steam engine, petrol engine and diesel engine, all have reciprocating parts such as piston, piston rod, etc.

15.9. Angular Velocity and Acceleration of the Connecting Rod

Consider the motion of a connecting rod and a crank as shown in Fig. 15.7. From the geometry of the figure, we find that

$$CQ = l \sin \phi = r \sin \theta$$

526 • Theory of Machines

$$\therefore \sin \phi = \frac{r}{l} \times \sin \theta = \frac{\sin \theta}{n} \quad \dots \left(\because n = \frac{l}{r} \right)$$

Differentiating both sides with respect to time t ,

$$\cos \phi \times \frac{d\phi}{dt} = \frac{\cos \theta}{n} \times \frac{d\theta}{dt} = \frac{\cos \theta}{n} \times \omega \quad \dots \left(\because \frac{d\theta}{dt} = \omega \right)$$

Since the angular velocity of the connecting rod PC is same as the angular velocity of point P with respect to C and is equal to $d\phi/dt$, therefore angular velocity of the connecting rod

$$\omega_{PC} = \frac{d\phi}{dt} = \frac{\cos \theta}{n} \times \frac{\omega}{\cos \phi} = \frac{\omega}{n} \times \frac{\cos \theta}{\cos \phi}$$

$$\text{We know that, } \cos \phi = \left(1 - \sin^2 \phi \right)^{\frac{1}{2}} = \left(1 - \frac{\sin^2 \theta}{n^2} \right)^{\frac{1}{2}} \quad \dots \left(\because \sin \phi = \frac{\sin \theta}{n} \right)$$

$$\begin{aligned} \therefore \omega_{PC} &= \frac{\omega}{n} \times \frac{\cos \theta}{\left(1 - \frac{\sin^2 \theta}{n^2} \right)^{\frac{1}{2}}} = \frac{\omega}{n} \times \frac{\cos \theta}{\frac{1}{n} (n^2 - \sin^2 \theta)^{1/2}} \\ &= \frac{\omega \cos \theta}{(n^2 - \sin^2 \theta)^{1/2}} \quad \dots (i) \end{aligned}$$

Angular acceleration of the connecting rod PC ,

$$\alpha_{PC} = \text{Angular acceleration of } P \text{ with respect to } C = \frac{d(\omega_{PC})}{dt}$$

We know that

$$\frac{d(\omega_{PC})}{dt} = \frac{d(\omega_{PC})}{d\theta} \times \frac{d\theta}{dt} = \frac{d(\omega_{PC})}{d\theta} \times \omega \quad \dots (ii)$$

$$\dots \left(\because \frac{d\theta}{dt} = \omega \right)$$

Now differentiating equation (i), we get

$$\begin{aligned} \frac{d(\omega_{PC})}{d\theta} &= \frac{d}{d\theta} \left[\frac{\omega \cos \theta}{(n^2 - \sin^2 \theta)^{1/2}} \right] \\ &= \omega \left[\frac{(n^2 - \sin^2 \theta)^{1/2} (-\sin \theta) - [(\cos \theta) \times \frac{1}{2} (n^2 - \sin^2 \theta)^{-1/2} \times -2 \sin \theta \cos \theta]}{n^2 - \sin^2 \theta} \right] \\ &= \omega \left[\frac{(n^2 - \sin^2 \theta)^{1/2} (-\sin \theta) + (n^2 - \sin^2 \theta)^{-1/2} \sin \theta \cos^2 \theta}{n^2 - \sin^2 \theta} \right] \\ &= -\omega \sin \theta \left[\frac{(n^2 - \sin^2 \theta)^{1/2} - (n^2 - \sin^2 \theta)^{-1/2} \cos^2 \theta}{n^2 - \sin^2 \theta} \right] \\ &= -\omega \sin \theta \left[\frac{(n^2 - \sin^2 \theta) - \cos^2 \theta}{(n^2 - \sin^2 \theta)^{3/2}} \right] \quad \dots [\text{Dividing and multiplying by } (n^2 - \sin^2 \theta)^{1/2}] \end{aligned}$$

$$= \frac{-\omega \sin \theta}{(n^2 - \sin^2 \theta)^{3/2}} \left[n^2 - (\sin^2 \theta + \cos^2 \theta) \right] = \frac{-\omega \sin \theta (n^2 - 1)}{(n^2 - \sin^2 \theta)^{3/2}}$$

...($\because \sin^2 \theta + \cos^2 \theta = 1$)

$$\therefore \alpha_{PC} = \frac{d(\omega_{PC})}{d\theta} \times \omega = \frac{-\omega^2 \sin \theta (n^2 - 1)}{(n^2 - \sin^2 \theta)^{3/2}} \quad \dots[\text{From equation (ii)}] \quad \dots(\text{iii})$$

The negative sign shows that the sense of the acceleration of the connecting rod is such that it tends to reduce the angle ϕ .

Notes: 1. Since $\sin^2 \theta$ is small as compared to n^2 , therefore it may be neglected. Thus, equations (i) and (iii) are reduced to

$$\omega_{PC} = \frac{\omega \cos \theta}{n}, \quad \text{and} \quad \alpha_{PC} = \frac{-\omega^2 \sin \theta (n^2 - 1)}{n^3}$$

2. Also in equation (iii), unity is small as compared to n^2 , hence the term unity may be neglected.

$$\therefore \alpha_{PC} = \frac{-\omega^2 \sin \theta}{n}$$

Example 15.3. If the crank and the connecting rod are 300 mm and 1 m long respectively and the crank rotates at a constant speed of 200 r.p.m., determine: 1. The crank angle at which the maximum velocity occurs, and 2. Maximum velocity of the piston.

Solution. Given : $r = 300 \text{ mm} = 0.3 \text{ m}$; $l = 1 \text{ m}$; $N = 200 \text{ r.p.m.}$ or $\omega = 2\pi \times 200/60 = 20.95 \text{ rad/s}$

1. Crank angle at which the maximum velocity occurs

Let $\theta =$ Crank angle from the inner dead centre at which the maximum velocity occurs.

We know that ratio of length of connecting rod to crank radius,

$$n = l/r = 1/0.3 = 3.33$$

and velocity of the piston,

$$v_P = \omega.r \left(\sin \theta + \frac{\sin 2\theta}{2n} \right) \quad \dots(\text{i})$$

For maximum velocity of the piston,

$$\frac{dv_P}{d\theta} = 0 \quad \text{i.e.} \quad \omega.r \left(\cos \theta + \frac{2 \cos 2\theta}{2n} \right) = 0$$

or $n \cos \theta + 2 \cos^2 \theta - 1 = 0$...($\because \cos 2\theta = 2 \cos^2 \theta - 1$)

$$2 \cos^2 \theta + 3.33 \cos \theta - 1 = 0$$

$$\therefore \cos \theta = \frac{-3.33 \pm \sqrt{(3.33)^2 + 4 \times 2 \times 1}}{2 \times 2} = 0.26 \quad \dots(\text{Taking + ve sign})$$

or $\theta = 75^\circ$ **Ans.**

2. Maximum velocity of the piston

Substituting the value of $\theta = 75^\circ$ in equation (i), maximum velocity of the piston,

$$v_{P(max)} = \omega.r \left[\sin 75^\circ + \frac{\sin 150^\circ}{2n} \right] = 20.95 \times 0.3 \left[0.966 + \frac{0.5}{3.33} \right] \text{ m/s}$$

$$= 6.54 \text{ m/s} \quad \text{Ans.}$$

Example 15.4. The crank and connecting rod of a steam engine are 0.3 m and 1.5 m in length. The crank rotates at 180 r.p.m. clockwise. Determine the velocity and acceleration of the piston when the crank is at 40 degrees from the inner dead centre position. Also determine the position of the crank for zero acceleration of the piston.

Solution. Given : $r = 0.3$; $l = 1.5$ m ; $N = 180$ r.p.m. or $\omega = \pi \times 180/60 = 18.85$ rad/s; $\theta = 40^\circ$

Velocity of the piston

We know that ratio of lengths of the connecting rod and crank,

$$n = l/r = 1.5/0.3 = 5$$

\therefore Velocity of the piston,

$$v_p = \omega.r \left(\sin \theta + \frac{\sin 2\theta}{2n} \right) = 18.85 \times 0.3 \left(\sin 40^\circ + \frac{\sin 80^\circ}{2 \times 5} \right) \text{ m/s}$$

$$= 4.19 \text{ m/s} \quad \text{Ans.}$$

Acceleration of the piston

We know that acceleration of piston,

$$a_p = \omega^2.r \left(\cos \theta + \frac{\cos 2\theta}{n} \right) = (18.85)^2 \times 0.3 \left(\cos 40^\circ + \frac{\cos 80^\circ}{5} \right) \text{ m/s}^2$$

$$= 85.35 \text{ m/s}^2 \quad \text{Ans.}$$

Position of the crank for zero acceleration of the piston

Let θ_1 = Position of the crank from the inner dead centre for zero acceleration of the piston.

We know that acceleration of piston,

$$a_p = \omega^2.r \left(\cos \theta_1 + \frac{\cos 2\theta_1}{n} \right)$$

or
$$0 = \frac{\omega^2.r}{n} (n \cos \theta_1 + \cos 2\theta_1) \quad \dots (\because a_p = 0)$$

$$\therefore n \cos \theta_1 + \cos 2\theta_1 = 0$$

$$5 \cos \theta_1 + 2 \cos^2 \theta_1 - 1 = 0 \quad \text{or} \quad 2 \cos^2 \theta_1 + 5 \cos \theta_1 - 1 = 0$$

$$\therefore \cos \theta_1 = \frac{-5 \pm \sqrt{5^2 + 4 \times 1 \times 2}}{2 \times 2} = 0.1862 \quad \dots (\text{Taking + ve sign})$$

or
$$\theta_1 = 79.27^\circ \text{ or } 280.73^\circ \quad \text{Ans.}$$

Example 15.5. In a slider crank mechanism, the length of the crank and connecting rod are 150 mm and 600 mm respectively. The crank position is 60° from inner dead centre. The crank shaft speed is 450 r.p.m. (clockwise). Using analytical method, determine: 1. Velocity and acceleration of the slider, and 2. Angular velocity and angular acceleration of the connecting rod.

Solution. Given : $r = 150$ mm = 0.15 m ; $l = 600$ mm = 0.6 m ; $\theta = 60^\circ$; $N = 400$ r.p.m or $\omega = \pi \times 450/60 = 47.13$ rad/s

1. Velocity and acceleration of the slider

We know that ratio of the length of connecting rod and crank,

$$n = l/r = 0.6/0.15 = 4$$

∴ Velocity of the slider,

$$v_p = \omega.r \left(\sin \theta + \frac{\sin 2\theta}{2n} \right) = 47.13 \times 0.15 \left(\sin 60^\circ + \frac{\sin 120^\circ}{2 \times 4} \right) \text{ m/s}$$

$$= 6.9 \text{ m/s Ans.}$$

and acceleration of the slider,

$$a_p = \omega^2.r \left(\cos \theta + \frac{\cos 2\theta}{n} \right) = (47.13)^2 \times 0.15 \left(\cos 60^\circ + \frac{\cos 120^\circ}{4} \right) \text{ m/s}^2$$

$$= 124.94 \text{ m/s}^2 \text{ Ans.}$$

2. Angular velocity and angular acceleration of the connecting rod

We know that angular velocity of the connecting rod,

$$\omega_{PC} = \frac{\omega \cos \theta}{n} = \frac{47.13 \times \cos 60^\circ}{4} = 5.9 \text{ rad/s Ans.}$$

and angular acceleration of the connecting rod,

$$\alpha_{PC} = \frac{\omega^2 \sin \theta}{n} = \frac{(47.13)^2 \times \sin 60^\circ}{4} = 481 \text{ rad/s}^2 \text{ Ans.}$$

15.10. Forces on the Reciprocating Parts of an Engine, Neglecting the Weight of the Connecting Rod

The various forces acting on the reciprocating parts of a horizontal engine are shown in Fig. 15.8. The expressions for these forces, neglecting the weight of the connecting rod, may be derived as discussed below :

1. Piston effort. It is the net force acting on the piston or crosshead pin, along the line of stroke. It is denoted by F_p in Fig. 15.8.

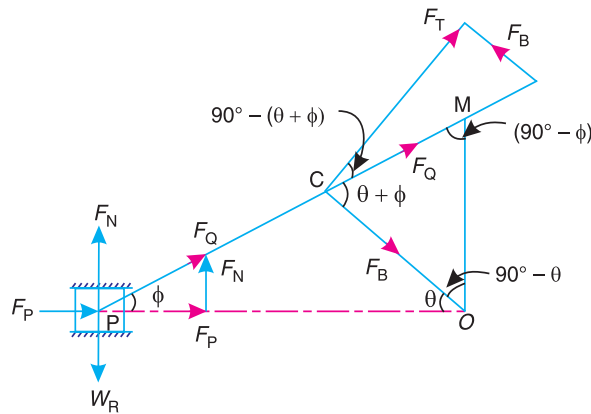

Fig. 15.8. Forces on the reciprocating parts of an engine.

Let m_R = Mass of the reciprocating parts, e.g. piston, crosshead pin or gudgeon pin etc., in kg, and

W_R = Weight of the reciprocating parts in newtons = $m_R.g$

We know that acceleration of the reciprocating parts,

$$a_R = a_p = \omega^2.r \left(\cos \theta + \frac{\cos 2\theta}{n} \right)$$

530 • Theory of Machines

∴ *Accelerating force or inertia force of the reciprocating parts,

$$F_I = m_R \cdot a_R = m_R \cdot \omega^2 \cdot r \left(\cos \theta + \frac{\cos 2\theta}{n} \right)$$

It may be noted that in a horizontal engine, the reciprocating parts are accelerated from rest, during the latter half of the stroke (*i.e.* when the piston moves from inner dead centre to outer dead centre). It is, then, retarded during the latter half of the stroke (*i.e.* when the piston moves from outer dead centre to inner dead centre). The inertia force due to the acceleration of the reciprocating parts, opposes the force on the piston due to the difference of pressures in the cylinder on the two sides of the piston. On the other hand, the inertia force due to retardation of the reciprocating parts, helps the force on the piston. Therefore,



Connecting rod of a petrol engine.

$$\begin{aligned} \text{Piston effort, } F_p &= \text{Net load on the piston} \mp \text{Inertia force} \\ &= F_L \mp F_I \quad \dots(\text{Neglecting frictional resistance}) \\ &= F_L \mp F_I - R_F \quad \dots(\text{Considering frictional resistance}) \end{aligned}$$

where R_F = Frictional resistance.

The -ve sign is used when the piston is accelerated, and +ve sign is used when the piston is retarded.

In a double acting reciprocating steam engine, net load on the piston,

$$F_L = p_1 A_1 - p_2 A_2 = p_1 A_1 - p_2 (A_1 - a)$$

where p_1, A_1 = Pressure and cross-sectional area on the back end side of the piston,
 p_2, A_2 = Pressure and cross-sectional area on the crank end side of the piston,
 a = Cross-sectional area of the piston rod.

Notes : 1. If 'p' is the net pressure of steam or gas on the piston and D is diameter of the piston, then

$$\text{Net load on the piston, } F_L = \text{Pressure} \times \text{Area} = p \times \frac{\pi}{4} \times D^2$$

2. In case of a vertical engine, the weight of the reciprocating parts assists the piston effort during the downward stroke (*i.e.* when the piston moves from top dead centre to bottom dead centre) and opposes during the upward stroke of the piston (*i.e.* when the piston moves from bottom dead centre to top dead centre).

$$\therefore \text{Piston effort, } F_p = F_L \mp F_I \pm W_R - R_F$$

2. Force acting along the connecting rod. It is denoted by F_Q in Fig. 15.8. From the geometry of the figure, we find that

$$F_Q = \frac{F_p}{\cos \phi}$$

* The acceleration of the reciprocating parts by Klien's construction is,

$$\begin{aligned} a_p &= \omega^2 \times NO \\ \therefore F_I &= m_R \cdot \omega^2 \times NO \end{aligned}$$

We know that $\cos \phi = \sqrt{1 - \frac{\sin^2 \theta}{n^2}}$

$$\therefore F_Q = \frac{F_P}{\sqrt{1 - \frac{\sin^2 \theta}{n^2}}}$$

3. Thrust on the sides of the cylinder walls or normal reaction on the guide bars. It is denoted by F_N in Fig. 15.8. From the figure, we find that

$$F_N = F_Q \sin \phi = \frac{F_P}{\cos \phi} \times \sin \phi = F_P \tan \phi \quad \dots \left[\because F_Q = \frac{F_P}{\cos \phi} \right]$$

4. Crank-pin effort and thrust on crank shaft bearings. The force acting on the connecting rod F_Q may be resolved into two components, one perpendicular to the crank and the other along the crank. The component of F_Q perpendicular to the crank is known as **crank-pin effort** and it is **denoted by F_T** in Fig. 15.8. The component of F_Q along the crank produces a thrust on the crank shaft bearings and it is denoted by F_B in Fig. 15.8.

Resolving F_Q perpendicular to the crank,

$$F_T = F_Q \sin (\theta + \phi) = \frac{F_P}{\cos \phi} \times \sin (\theta + \phi)$$

and resolving F_Q along the crank,

$$F_B = F_Q \cos (\theta + \phi) = \frac{F_P}{\cos \phi} \times \cos (\theta + \phi)$$

5. Crank effort or turning moment or torque on the crank shaft. The product of the crank-pin effort (F_T) and the crank pin radius (r) is known as **crank effort** or **turning moment** or **torque on the crank shaft**. Mathematically,

$$\begin{aligned} \text{Crank effort, } T &= F_T \times r = \frac{F_P \sin (\theta + \phi)}{\cos \phi} \times r \\ &= \frac{F_P (\sin \theta \cos \phi + \cos \theta \sin \phi)}{\cos \phi} \times r \\ &= F_P \left(\sin \theta + \cos \theta \times \frac{\sin \phi}{\cos \phi} \right) \times r \\ &= F_P (\sin \theta + \cos \theta \tan \phi) \times r \quad \dots (i) \end{aligned}$$

We know that $l \sin \phi = r \sin \theta$

$$\sin \phi = \frac{r}{l} \sin \theta = \frac{\sin \theta}{n} \quad \dots \left(\because n = \frac{l}{r} \right)$$

and $\cos \phi = \sqrt{1 - \sin^2 \phi} = \sqrt{1 - \frac{\sin^2 \theta}{n^2}} = \frac{1}{n} \sqrt{n^2 - \sin^2 \theta}$

$$\therefore \tan \phi = \frac{\sin \phi}{\cos \phi} = \frac{\sin \theta}{n} \times \frac{n}{\sqrt{n^2 - \sin^2 \theta}} = \frac{\sin \theta}{\sqrt{n^2 - \sin^2 \theta}}$$

532 • Theory of Machines

Substituting the value of $\tan \phi$ in equation (i), we have crank effort,

$$T = F_P \left(\sin \theta + \frac{\cos \theta \sin \theta}{\sqrt{n^2 - \sin^2 \theta}} \right) \times r$$

$$= F_P \times r \left(\sin \theta + \frac{\sin 2\theta}{2\sqrt{n^2 - \sin^2 \theta}} \right) \quad \dots(ii)$$

...($\because 2 \cos \theta \sin \theta = \sin 2\theta$)

Note: Since $\sin^2 \theta$ is very small as compared to n^2 therefore neglecting $\sin^2 \theta$, we have,

Crank effort, $T = F_P \times r \left(\sin \theta + \frac{\sin 2\theta}{2n} \right) = F_P \times OM$

We have seen in Art. 15.8, that

$$OM = r \left(\sin \theta + \frac{\sin 2\theta}{2n} \right)$$

Therefore, it is convenient to find OM instead of solving the large expression.

Example 15.6. Find the inertia force for the following data of an I.C. engine.

Bore = 175 mm, stroke = 200 mm, engine speed = 500 r.p.m., length of connecting rod = 400 mm, crank angle = 60° from T.D.C and mass of reciprocating parts = 180 kg.

Solution. Given : *D=175 mm ; L=200 mm = 0.2 m or $r = L / 2 = 0.1$ m ; N = 500 r.p.m. or $\omega = 2\pi \times 500/60 = 52.4$ rad/s ; l = 400 mm = 0.4 m ; $m_R = 180$ kg

The inertia force may be calculated by graphical method or analytical method as discussed below:

1. Graphical method

First of all, draw the Klien's acceleration diagram $OCQN$ to some suitable scale as shown in Fig. 15.9. By measurement,

$$ON = 38 \text{ mm} = 0.038 \text{ m}$$

\therefore Acceleration of the reciprocating parts,

$$a_R = \omega^2 \times ON$$

$$= (52.4)^2 \times 0.038 = 104.34 \text{ m/s}^2$$

We know that inertia force,

$$F_I = m_R \times a_R = 180 \times 104.34 \text{ N}$$

$$= 18\,780 \text{ N} = 18.78 \text{ kN Ans.}$$

2. Analytical method

We know that ratio of lengths of connecting rod and crank,

$$n = l / r = 0.4 / 0.1 = 4$$

\therefore Inertia force, $F_I = m_R \cdot \omega^2 \cdot r \left(\cos \theta + \frac{\cos 2\theta}{n} \right)$

$$= 180 \times (52.4)^2 \times 0.1 \left(\cos 60^\circ + \frac{\cos 120^\circ}{4} \right) = 18\,530 \text{ N}$$

$$= 18.53 \text{ kN Ans.}$$

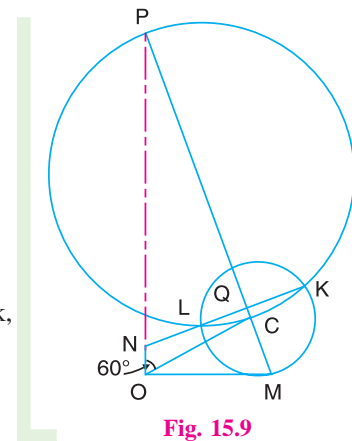

Fig. 15.9

* Superfluous data.

Example 15.7. The crank-pin circle radius of a horizontal engine is 300 mm. The mass of the reciprocating parts is 250 kg. When the crank has travelled 60° from I.D.C., the difference between the driving and the back pressures is 0.35 N/mm^2 . The connecting rod length between centres is 1.2 m and the cylinder bore is 0.5 m. If the engine runs at 250 r.p.m. and if the effect of piston rod diameter is neglected, calculate : **1.** pressure on slide bars, **2.** thrust in the connecting rod, **3.** tangential force on the crank-pin, and **4.** turning moment on the crank shaft.

Solution. Given: $r = 300 \text{ mm} = 0.3 \text{ m}$; $m_R = 250 \text{ kg}$; $\theta = 60^\circ$; $p_1 - p_2 = 0.35 \text{ N/mm}^2$; $l = 1.2 \text{ m}$; $D = 0.5 \text{ m} = 500 \text{ mm}$; $N = 250 \text{ r.p.m.}$ or $\omega = 2\pi \times 250/60 = 26.2 \text{ rad/s}$

First of all, let us find out the piston effort (F_p).

We know that net load on the piston,

$$F_L = (p_1 - p_2) \frac{\pi}{4} \times D^2 = 0.35 \times \frac{\pi}{4} (500)^2 = 68730 \text{ N}$$

...(∵ Force = Pressure × Area)

Ratio of length of connecting rod and crank,

$$n = l/r = 1.2/0.3 = 4$$

and accelerating or inertia force on reciprocating parts,

$$\begin{aligned} F_I &= m_R \cdot \omega^2 r \left(\cos \theta + \frac{\cos 2\theta}{n} \right) \\ &= 250 (26.2)^2 \cdot 0.3 \left(\cos 60^\circ + \frac{\cos 120^\circ}{4} \right) = 19306 \text{ N} \end{aligned}$$

∴ Piston effort, $F_p = F_L - F_I = 68730 - 19306 = 49424 \text{ N} = 49.424 \text{ kN}$

1. Pressure on slide bars

Let ϕ = Angle of inclination of the connecting rod to the line of stroke.

We know that, $\sin \phi = \frac{\sin \theta}{n} = \frac{\sin 60^\circ}{4} = \frac{0.866}{4} = 0.2165$

∴ $\phi = 12.5^\circ$

We know that pressure on the slide bars,

$$F_N = F_p \tan \phi = 49.424 \times \tan 12.5^\circ = 10.96 \text{ kN} \quad \text{Ans.}$$

2. Thrust in the connecting rod

We know that thrust in the connecting rod,

$$F_Q = \frac{F_p}{\cos \phi} = \frac{49.424}{\cos 12.5^\circ} = 50.62 \text{ kN} \quad \text{Ans.}$$

3. Tangential force on the crank-pin

We know that tangential force on the crank pin,

$$F_T = F_Q \sin (\theta + \phi) = 50.62 \sin (60^\circ + 12.5^\circ) = 48.28 \text{ kN} \quad \text{Ans.}$$

4. Turning moment on the crank shaft

We know that turning moment on the crank shaft,

$$T = F_T \times r = 48.28 \times 0.3 = 14.484 \text{ kN-m} \quad \text{Ans.}$$

534 • Theory of Machines

Example 15.8. A vertical double acting steam engine has a cylinder 300 mm diameter and 450 mm stroke and runs at 200 r.p.m. The reciprocating parts has a mass of 225 kg and the piston rod is 50 mm diameter. The connecting rod is 1.2 m long. When the crank has turned through 125° from the top dead centre, the steam pressure above the piston is 30 kN/m^2 and below the piston is 1.5 kN/m^2 . Calculate the effective turning moment on the crank shaft.

Solution. Given : $D = 300 \text{ mm} = 0.3 \text{ m}$; $L = 450 \text{ mm}$ or $r = L/2 = 225 \text{ mm} = 0.225 \text{ m}$; $N = 200 \text{ r.p.m.}$ or $\omega = 2\pi \times 200/60 = 20.95 \text{ rad/s}$; $m_R = 225 \text{ kg}$; $d = 50 \text{ mm} = 0.05 \text{ m}$; $l = 1.2 \text{ m}$; $\theta = 125^\circ$; $p_1 = 30 \text{ kN/m}^2 = 30 \times 10^3 \text{ N/m}^2$; $p_2 = 1.5 \text{ kN/m}^2 = 1.5 \times 10^3 \text{ N/m}^2$

We know that area of the piston,

$$A_1 = \frac{\pi}{4} \times D^2 = \frac{\pi}{4} \times (0.3)^2 = 0.0707 \text{ m}^2$$

and area of the piston rod, $a = \frac{\pi}{4} \times d^2 = \frac{\pi}{4} \times (0.05)^2 = 0.00196 \text{ m}^2$

∴ Force on the piston due to steam pressure,

$$\begin{aligned} F_L &= p_1 A_1 - p_2 (A_1 - a) \\ &= 30 \times 10^3 \times 0.0707 - 1.5 \times 10^3 (0.0707 - 0.00196) \text{ N} \\ &= 2121 - 103 = 2018 \text{ N} \end{aligned}$$

Ratio of lengths of connecting rod and crank,

$$n = l/r = 1.2/0.225 = 5.33$$

and inertia force on the reciprocating parts,

$$\begin{aligned} F_I &= m_R \cdot \omega^2 \cdot r \left(\cos \theta + \frac{\cos 2\theta}{n} \right) \\ &= 225 (20.95)^2 \times 0.225 \left(\cos 125^\circ + \frac{\cos 250^\circ}{5.33} \right) = -14172 \text{ N} \end{aligned}$$

We know that for a vertical engine, net force on the piston or piston effort,

$$\begin{aligned} F_P &= F_L - F_I + m_R \cdot g \\ &= 2018 - (-14172) + 225 \times 9.81 = 18397 \text{ N} \end{aligned}$$

Let ϕ = Angle of inclination of the connecting rod to the line of stroke.

We know that, $\sin \phi = \frac{\sin \theta}{n} = \frac{\sin 125^\circ}{5.33} = \frac{0.8191}{5.33} = 0.1537$

∴ $\phi = 8.84^\circ$

We know that effective turning moment on the crank shaft,

$$\begin{aligned} T &= \frac{F_P \times \sin(\theta + \phi)}{\cos \phi} \times r = \frac{18397 \sin(125^\circ + 8.84^\circ)}{\cos 8.84^\circ} \times 0.225 \text{ N-m} \\ &= 3021.6 \text{ N-m} \text{ Ans.} \end{aligned}$$

Example 15.9. The crank and connecting rod of a petrol engine, running at 1800 r.p.m. are 50 mm and 200 mm respectively. The diameter of the piston is 80 mm and the mass of the reciprocating parts is 1 kg. At a point during the power stroke, the pressure on the piston is 0.7 N/mm^2 , when it has moved 10 mm from the inner dead centre. Determine : 1. Net load on the gudgeon pin, 2. Thrust in the connecting rod, 3. Reaction between the piston and cylinder, and 4. The engine speed at which the above values become zero.

Solution. Given : $N = 1800 \text{ r.p.m.}$ or $\omega = 2\pi \times 1800/60 = 188.52 \text{ rad/s}$; $r = 50 \text{ mm} = 0.05 \text{ m}$; $l = 200 \text{ mm}$; $D = 80 \text{ mm}$; $m_R = 1 \text{ kg}$; $p = 0.7 \text{ N/mm}^2$; $x = 10 \text{ mm}$

1. Net load on the gudgeon pin

We know that load on the piston,

$$F_L = \frac{\pi}{4} D^2 \times p = \frac{\pi}{4} \times (80)^2 \times 0.7 = 3520 \text{ N}$$

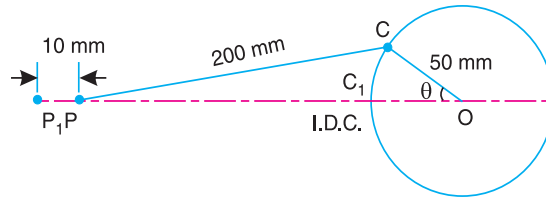

Fig. 15.10

When the piston has moved 10 mm from the inner dead centre, *i.e.* when $P_1P = 10 \text{ mm}$, the crank rotates from OC_1 to OC through an angle θ as shown in Fig. 15.10.

By measurement, we find that $\theta = 33^\circ$.

We know that ratio of lengths of connecting rod and crank,

$$n = l/r = 200/50 = 4$$

and inertia force on the reciprocating parts,

$$\begin{aligned} F_I &= m_R \cdot a_R = m_R \cdot \omega^2 \cdot r \left(\cos \theta + \frac{\cos 2\theta}{n} \right) \\ &= 1 \times (188.52)^2 \times 0.05 \left(\cos 33^\circ + \frac{\cos 66^\circ}{4} \right) = 1671 \text{ N} \end{aligned}$$

We know that net load on the gudgeon pin,

$$F_p = F_L - F_I = 3520 - 1671 = 1849 \text{ N Ans.}$$

2. Thrust in the connecting rod

Let

ϕ = Angle of inclination of the connecting rod to the line of stroke.

We know that,

$$\sin \phi = \frac{\sin \theta}{n} = \frac{\sin 33^\circ}{4} = \frac{0.5446}{4} = 0.1361$$

\therefore

$$\phi = 7.82^\circ$$

* The angle θ may also be obtained as follows:

We know that

$$x = r \left[(1 - \cos \theta) + \frac{\sin^2 \theta}{2n} \right] = r \left[(1 - \cos \theta) + \frac{1 - \cos^2 \theta}{2n} \right]$$

$$\begin{aligned} 10 &= 50 \left[(1 - \cos \theta) + \frac{1 - \cos^2 \theta}{2 \times 4} \right] = \frac{50}{8} [8 - 8 \cos \theta + 1 - \cos^2 \theta] \\ &= 50 - 50 \cos \theta + 6.25 - 6.25 \cos^2 \theta \end{aligned}$$

or $6.25 \cos^2 \theta + 50 \cos \theta - 56.25 = 0$

Solving this quadratic equation, we get $\theta = 33.14^\circ$



Twin-cylinder aeroplane engine.

We know that thrust in the connecting rod,

$$F_Q = \frac{F_P}{\cos \phi} = \frac{1849}{\cos 7.82^\circ} = 1866.3 \text{ N } \text{Ans.}$$

3. Reaction between the piston and cylinder

We know that reaction between the piston and cylinder,

$$F_N = F_P \tan \phi = 1849 \tan 7.82^\circ = 254 \text{ N } \text{Ans.}$$

4. Engine speed at which the above values will become zero

A little consideration will show that the above values will become zero, if the inertia force on the reciprocating parts (F_I) is equal to the load on the piston (F_L). Let ω_1 be the speed in rad/s, at which $F_I = F_L$.

$$\therefore m_R (\omega_1)^2 r \left(\cos \theta + \frac{\cos 2\theta}{n} \right) = \frac{\pi}{4} D^2 \times p$$

$$1 (\omega_1)^2 \times 0.05 \left(\cos 33^\circ + \frac{\cos 66^\circ}{4} \right) = \frac{\pi}{4} \times (80)^2 \times 0.7 \quad \text{or} \quad 0.047 (\omega_1)^2 = 3520$$

$$\therefore (\omega_1)^2 = 3520 / 0.047 = 74\,894 \quad \text{or} \quad \omega_1 = 273.6 \text{ rad/s}$$

\therefore Corresponding speed in r.p.m.,

$$N_1 = 273.6 \times 60 / 2\pi = 2612 \text{ r.p.m. } \text{Ans.}$$

Example 15.10. During a trial on steam engine, it is found that the acceleration of the piston is 36 m/s^2 when the crank has moved 30° from the inner dead centre position. The net effective steam pressure on the piston is 0.5 N/mm^2 and the frictional resistance is equivalent to a force of 600 N . The diameter of the piston is 300 mm and the mass of the reciprocating parts is 180 kg . If the length of the crank is 300 mm and the ratio of the connecting rod length to the crank length is 4.5 , find: **1.** Reaction on the guide bars, **2.** Thrust on the crank shaft bearings, and **3.** Turning moment on the crank shaft.

Solution. Given : $a_p = 36 \text{ m/s}^2$; $\theta = 30^\circ$; $p = 0.5 \text{ N/mm}^2$; $R_F = 600 \text{ N}$; $D = 300 \text{ mm}$; $m_R = 180 \text{ kg}$; $r = 300 \text{ mm} = 0.3 \text{ m}$; $n = l / r = 4.5$

1. Reaction on the guide bars

First of all, let us find the piston effort (F_P). We know that load on the piston,

$$F_L = p \times \frac{\pi}{4} \times D^2 = 0.5 \times \frac{\pi}{4} \times (300)^2 = 35350 \text{ N}$$

and inertia force due to reciprocating parts,

$$F_I = m_R \times a_p = 180 \times 36 = 6480 \text{ N}$$

$$\therefore \text{Piston effort, } F_P = F_L - F_I - R_F = 35\,350 - 6480 - 600 = 28\,270 \text{ N} = 28.27 \text{ kN}$$

Let ϕ = Angle of inclination of the connecting rod to the line of stroke.

$$\text{We know that } \sin \phi = \sin \theta/n = \sin 30^\circ/4.5 = 0.1111$$

$$\therefore \phi = 6.38^\circ$$

We know that reaction on the guide bars,

$$F_N = F_P \tan \phi = 28.27 \tan 6.38^\circ = 3.16 \text{ kN Ans.}$$

2. Thrust on the crank shaft bearing

We know that thrust on the crank shaft bearings,

$$F_B = \frac{F_P \cos(\theta + \phi)}{\cos \phi} = \frac{28.27 \cos(30^\circ + 6.38^\circ)}{\cos 6.38^\circ} = 22.9 \text{ kN Ans.}$$

3. Turning moment on the crank shaft

We know that turning moment on the crank shaft,

$$T = \frac{F_P \sin(\theta + \phi)}{\cos \phi} \times r = \frac{28.27 \sin(30^\circ + 6.38^\circ)}{\cos 6.38^\circ} \times 0.3 \text{ kN-m}$$

$$= 5.06 \text{ kN-m}$$

Example 15.11. A vertical petrol engine 100 mm diameter and 120 mm stroke has a connecting rod 250 mm long. The mass of the piston is 1.1 kg. The speed is 2000 r.p.m. On the expansion stroke with a crank 20° from top dead centre, the gas pressure is 700 kN/m². Determine:

1. Net force on the piston,
2. Resultant load on the gudgeon pin,
3. Thrust on the cylinder walls, and
4. Speed above which, other things remaining same, the gudgeon pin load would be reversed in direction.

Solution. Given: $D = 100 \text{ mm} = 0.1 \text{ m}$; $L = 120 \text{ mm} = 0.12 \text{ m}$ or $r = L/2 = 0.06 \text{ m}$; $l = 250 \text{ mm} = 0.25 \text{ m}$; $m_R = 1.1 \text{ kg}$; $N = 2000 \text{ r.p.m.}$ or $\omega = 2\pi \times 2000/60 = 209.5 \text{ rad/s}$; $\theta = 20^\circ$; $p = 700 \text{ kN/m}^2$

1. Net force on the piston

The configuration diagram of a vertical engine is shown in Fig. 15.11.

We know that force due to gas pressure,

$$F_L = p \times \frac{\pi}{4} \times D^2 = 700 \times \frac{\pi}{4} \times (0.1)^2 = 5.5 \text{ kN}$$

$$= 5500 \text{ N}$$

and ratio of lengths of the connecting rod and crank,

$$n = l/r = 0.25/0.06 = 4.17$$

\therefore Inertia force on the piston,

$$F_I = m_R \cdot \omega^2 \cdot r \left(\cos \theta + \frac{\cos 2\theta}{n} \right)$$

$$= 1.1 \times (209.5)^2 \times 0.06 \times \left(\cos 20^\circ + \frac{\cos 40^\circ}{4.17} \right)$$

$$= 3254 \text{ N}$$

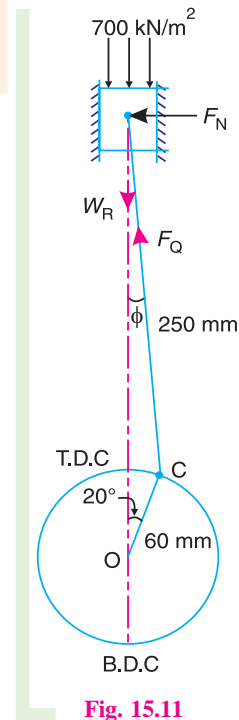

Fig. 15.11

538 • Theory of Machines

We know that for a vertical engine, net force on the piston,

$$F_p = F_L - F_I + W_R = F_L - F_I + m_R \cdot g$$

$$= 5500 - 3254 + 1.1 \times 9.81 = 2256.8 \text{ N Ans.}$$

2. Resultant load on the gudgeon pin

Let ϕ = Angle of inclination of the connecting rod to the line of stroke.

We know that,

$$\sin \phi = \sin \theta / n = \sin 20^\circ / 4.17 = 0.082$$

$$\therefore \phi = 4.7^\circ$$

We know that resultant load on the gudgeon pin,

$$F_Q = \frac{F_p}{\cos \phi} = \frac{2256.8}{\cos 4.7^\circ} = 2265 \text{ N Ans.}$$

3. Thrust on the cylinder walls

We know that thrust on the cylinder walls,

$$F_N = F_p \tan \phi = 2256.8 \times \tan 4.7^\circ = 185.5 \text{ N Ans.}$$

4. Speed, above which, the gudgeon pin load would be reversed in direction

Let N_1 = Required speed, in r.p.m.

The gudgeon pin load *i.e.* F_Q will be reversed in direction, if F_Q becomes negative. This is only possible when F_p is negative. Therefore, for F_p to be negative, F_I must be greater than $(F_L + W_R)$,

$$i.e. \quad m_R (\omega_1)^2 r \left(\cos \theta + \frac{\cos 2\theta}{n} \right) > 5500 + 1.1 \times 9.81$$

$$1.1 \times (\omega_1)^2 \times 0.06 \left(\cos 20^\circ + \frac{\cos 40^\circ}{4.17} \right) > 5510.8$$

$$0.074 (\omega_1)^2 > 5510.8 \quad \text{or} \quad (\omega_1)^2 > 5510.8 / 0.074 \quad \text{or} \quad 74\,470$$

or $\omega_1 > 273 \text{ rad/s}$

\therefore Corresponding speed in r.p.m.,

$$N_1 > 273 \times 60 / 2\pi \quad \text{or} \quad 2606 \text{ r.p.m. Ans.}$$

Example 15. 12. A horizontal steam engine running at 120 r.p.m. has a bore of 250 mm and a stroke of 400 mm. The connecting rod is 0.6 m and mass of the reciprocating parts is 60 kg. When the crank has turned through an angle of 45° from the inner dead centre, the steam pressure on the cover end side is 550 kN/m^2 and that on the crank end side is 70 kN/m^2 . Considering the diameter of the piston rod equal to 50 mm, determine:

1. turning moment on the crank shaft, 2. thrust on the bearings, and 3. acceleration of the flywheel, if the power of the engine is 20 kW, mass of the flywheel 60 kg and radius of gyration 0.6 m.

Solution. Given : $N = 120 \text{ r.p.m.}$ or $\omega = 2\pi \times 120 / 60 = 12.57 \text{ rad/s}$; $D = 250 \text{ mm} = 0.25 \text{ m}$; $L = 400 \text{ mm} = 0.4 \text{ m}$ or $r = L / 2 = 0.2 \text{ m}$; $l = 0.6 \text{ m}$; $m_R = 60 \text{ kg}$; $\theta = 45^\circ$; $d = 50 \text{ mm} = 0.05 \text{ m}$; $p_1 = 550 \text{ kN/m}^2 = 550 \times 10^3 \text{ N/m}^2$; $p_2 = 70 \text{ kN/m}^2 = 70 \times 10^3 \text{ N/m}^2$

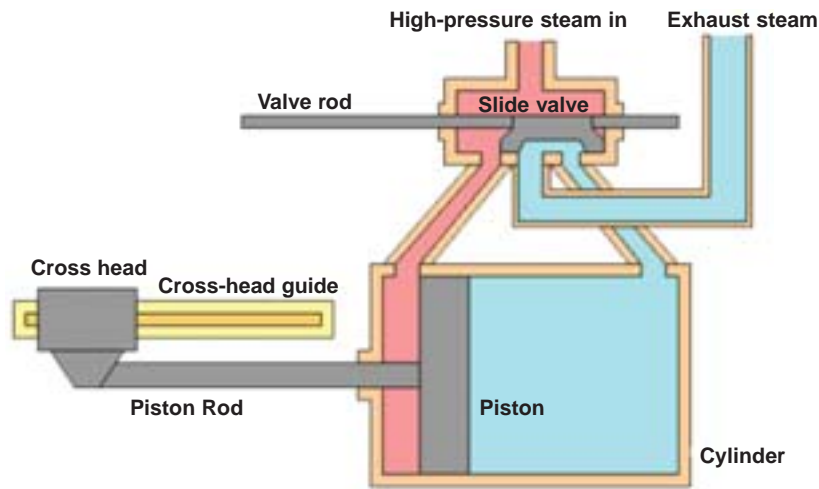

1. Turning moment on the crankshaft

First of all, let us find the net load on the piston (F_p).

We know that area of the piston on the cover end side,

$$A_1 = \frac{\pi}{4} \times D^2 = \frac{\pi}{4} \times (0.25)^2 = 0.049 \text{ m}^2$$

and area of piston rod, $a = \frac{\pi}{4} \times d^2 = \frac{\pi}{4} \times (0.05)^2 = 0.00196 \text{ m}^2$

∴ Net load on the piston,

$$\begin{aligned} F_L &= p_1 \cdot A_1 - p_2 \cdot A_2 = p_1 \cdot A_1 - p_2 (A_1 - a) \\ &= 550 \times 10^3 \times 0.049 - 70 \times 10^3 (0.049 - 0.00196) = 23657 \text{ N} \end{aligned}$$

We know that ratio of lengths of the connecting rod and crank,

$$n = l/r = 0.6/0.2 = 3$$

and inertia force on the reciprocating parts,

$$\begin{aligned} F_I &= m_R \cdot \omega^2 \cdot r \left(\cos \theta + \frac{\cos 2\theta}{n} \right) \\ &= 60 \times (12.57)^2 \times 0.2 \left(\cos 45^\circ + \frac{\cos 90^\circ}{3} \right) = 1340 \text{ N} \end{aligned}$$

∴ Net force on the piston or piston effort,

$$F_p = F_L - F_I = 23657 - 1340 = 22317 \text{ N} = 22.317 \text{ kN}$$

Let ϕ = Angle of inclination of the connecting rod to the line of stroke.

We know that, $\sin \phi = \sin \theta/n = \sin 45^\circ/3 = 0.2357$

∴ $\phi = 13.6^\circ$

We know that turning moment on the crankshaft,

$$\begin{aligned} T &= \frac{F_p \sin (\theta + \phi)}{\cos \phi} \times r = \frac{22.317 \times \sin (45^\circ + 13.6^\circ)}{\cos 13.6^\circ} \times 0.2 \text{ kN-m} \\ &= 3.92 \text{ kN-m} = 3920 \text{ N-m} \quad \text{Ans.} \end{aligned}$$

540 • Theory of Machines

2. Thrust on the bearings

We know that thrust on the bearings,

$$F_B = \frac{F_P \cos(\theta + \phi)}{\cos \phi} = \frac{22.317 \times \cos(45^\circ + 13.6^\circ)}{\cos 13.6^\circ} = 11.96 \text{ kN Ans.}$$

3. Acceleration of the flywheel

Given: $P = 20 \text{ kW} = 20 \times 10^3 \text{ W}$; $m = 60 \text{ kg}$; $k = 0.6 \text{ m}$

Let $\alpha =$ Acceleration of the flywheel in rad/s^2 .

We know that mass moment of inertia of the flywheel,

$$I = m.k^2 = 60 \times (0.6)^2 = 21.6 \text{ kg-m}^2$$

\therefore Accelerating torque, $T_A = I.\alpha = 21.6 \alpha \text{ N-m}$... (i)

and resisting torque, $T_R = \frac{P \times 60}{2\pi N} = \frac{20 \times 10^3 \times 60}{2\pi \times 120} = 1591 \text{ N-m}$ ($\because P = \frac{2\pi NT}{60}$)

Since the accelerating torque is equal to the difference of torques on the crankshaft or turning moment (T) and the resisting torque (T_R), therefore, accelerating torque,

$$T_A = T - T_R = 3920 - 1591 = 2329 \text{ N-m} \quad \dots (ii)$$

From equation (i) and (ii),

$$\alpha = 2329/21.6 = 107.8 \text{ rad/s}^2 \text{ Ans.}$$

Example 15.13. A vertical, single cylinder, single acting diesel engine has a cylinder diameter 300 mm, stroke length 500 mm, and connecting rod length 4.5 times the crank length. The engine runs at 180 r.p.m. The mass of the reciprocating parts is 280 kg. The compression ratio is 14 and the pressure remains constant during the injection of the oil for 1/10th of the stroke. If the compression and expansion follows the law $p.V^{1.35} = \text{constant}$, find:
1. Crank-pin effort, **2.** Thrust on the bearings, and **3.** Turning moment on the crank shaft, when the crank displacement is 45° from the inner dead centre position during expansion stroke.

The suction pressure may be taken as 0.1 N/mm^2 .

Solution. Given : $D = 300 \text{ mm} = 0.3 \text{ m}$;
 $L = 500 \text{ mm} = 0.5 \text{ m}$ or $r = 0.25 \text{ m}$; $l = 4.5 r$ or $n = l/r = 4.5$; $N = 180 \text{ r.p.m.}$ or
 $\omega = 2\pi \times 180/60 = 18.85 \text{ rad/s}$; $m_R = 280 \text{ kg}$; $\frac{V_1}{V_2} = 14$; $\theta = 45^\circ$; $p_1 = 0.1 \text{ N/mm}^2$

The pressure-volume (*i.e.* p - V) diagram for a *diesel engine is shown in Fig 15.12, in which 1-2 represents the compression, 2-3 represents the injection of fuel, 3-4 represents the expansion, and 4-1 represents the exhaust.

Let p_1, p_2, p_3 , and $p_4 =$ Pressures corresponding to points 1, 2, 3 and 4 respectively, and
 V_1, V_2, V_3 , and $V_4 =$ Volumes corresponding to points 1, 2, 3 and 4 respectively.

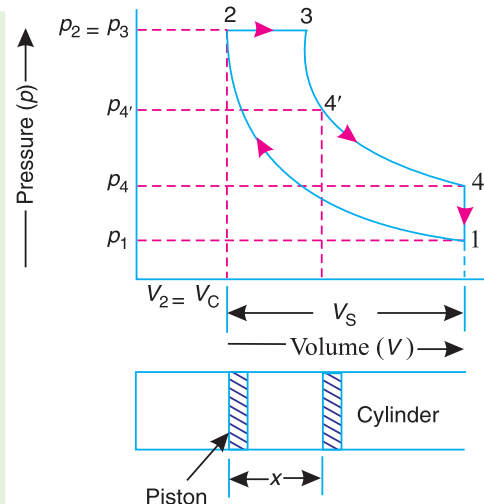

Fig. 15.12

* In a diesel engine, the compression and expansion are isentropic *i.e.* according to the law $p.V^\gamma = \text{constant}$. The injection of fuel takes place at constant pressure and the exhaust is at constant volume.

Since the compression follows the law $p \cdot V^{1.35} = \text{constant}$, therefore

$$p_1 (V_1)^{1.35} = p_2 (V_2)^{1.35}$$

or
$$p_2 = p_1 \left(\frac{V_1}{V_2} \right)^{1.35} = 0.1 \times (14)^{1.35} = 3.526 \text{ N/mm}^2$$

We know that swept volume,

$$V_S = \frac{\pi}{4} \times D^2 \times L = \frac{\pi}{4} \times (0.3)^2 \times 0.5 = 0.035 \text{ m}^3$$

and compression ratio,
$$= \frac{V_1}{V_2} = \frac{V_C + V_S}{V_C} = 1 + \frac{V_S}{V_C} \quad \dots (\because V_2 = V_C)$$

$$\therefore 14 = 1 + \frac{0.035}{V_C} \quad \text{or} \quad V_C = \frac{0.035}{14 - 1} = 0.0027 \text{ m}^3$$

Since the injection of fuel takes place at constant pressure (*i.e.* $p_2 = p_3$) and continues up to 1/10th of the stroke, therefore volume at the end of the injection of fuel,

$$V_3 = V_C + \frac{1}{10} \times V_S = 0.0027 + \frac{0.035}{10} = 0.0062 \text{ m}^3$$

When the crank displacement is 45° (*i.e.* when $\theta = 45^\circ$) from the inner dead centre during expansion stroke, the corresponding displacement of the piston (marked by point 4' on the p - V diagram) is given by

$$\begin{aligned} x &= r \left[(1 - \cos \theta) + \frac{\sin^2 \theta}{2n} \right] = r \left[(1 - \cos 45^\circ) + \frac{\sin^2 45^\circ}{2 \times 4.5} \right] \\ &= 0.25 \left[(1 - 0.707) + \frac{0.5}{9} \right] = 0.087 \text{ m} \end{aligned}$$

$$\therefore V_4' = V_C + \frac{\pi}{4} \times D^2 \times x = 0.0027 + \frac{\pi}{4} \times (0.3)^2 \times 0.087 = 0.0088 \text{ m}^3$$

Since the expansion follows the law $p \cdot V^{1.35} = \text{constant}$, therefore,

$$p_3 (V_3)^{1.35} = p_{4'} (V_4')^{1.35}$$

$$\therefore p_{4'} = p_3 \left(\frac{V_3}{V_4'} \right)^{1.35} = 3.526 \left(\frac{0.0062}{0.0088} \right)^{1.35} = 2.2 \text{ N/mm}^2$$

Difference of pressures on two sides of the piston,

$$p = p_{4'} - p_1 = 2.2 - 0.1 = 2.1 \text{ N/mm}^2 = 2.1 \times 10^6 \text{ N/m}^2$$

\therefore Net load on the piston,

$$F_L = p \times \frac{\pi}{4} \times D^2 = 2.1 \times 10^6 \times \frac{\pi}{4} \times (0.3)^2 = 148\,460 \text{ N}$$

Inertia force on the reciprocating parts,

$$\begin{aligned} F_I &= m_R \cdot \omega^2 \cdot r \left(\cos \theta + \frac{\cos 2\theta}{n} \right) \\ &= 280 \times (18.85)^2 \times 0.25 \left(\cos 45^\circ + \frac{\cos 90^\circ}{4.5} \right) = 17\,585 \text{ N} \end{aligned}$$

542 • Theory of Machines

We know that net force on the piston or piston effort,

$$F_P = F_L - F_I + W_R = F_L - F_I + m_R \cdot g$$

$$= 148460 - 17858 + 280 \times 9.81 = 133622 \text{ N}$$

1. Crank-pin effort

Let ϕ = Angle of inclination of the connecting rod to the line of stroke.

We know that, $\sin \phi = \sin \theta / n = \sin 45^\circ / 4.5 = 0.1571$

$\therefore \phi = 9.04^\circ$

We know that crank-pin effort,

$$F_T = \frac{F_P \sin (\theta + \phi)}{\cos \phi} = \frac{133622 \times \sin (45^\circ + 9.04^\circ)}{\cos 9.04^\circ} = 109522 \text{ N}$$

$$= 109.522 \text{ kN Ans.}$$

2. Thrust on the bearings

We know that thrust on the bearings,

$$F_B = \frac{F_P \cdot \cos (\theta + \phi)}{\cos \phi} = \frac{133622 \times \sin (45^\circ + 9.04^\circ)}{\cos 9.04^\circ} = 79456 \text{ N}$$

$$= 79.956 \text{ kN Ans.}$$

3. Turning moment on the crankshaft

We know that the turning moment on the crankshaft,

$$T = F_T \times r = 109.522 \times 0.25 = 27.38 \text{ kN-m Ans.}$$

Example 15.14. A vertical double acting steam engine has cylinder diameter 240 mm, length of stroke 360 mm and length of connecting rod 0.6 m. The crank rotates at 300 r.p.m. and the mass of the reciprocating parts is 160 kg. The steam is admitted at a pressure of 8 bar gauge and cut-off takes place at 1/3rd of the stroke. The expansion of steam is hyperbolic. The exhaust of steam takes place at a pressure of -0.75 bar gauge. The frictional resistance is equivalent to a force of 500 N. Determine the turning moment on the crankshaft, when the piston is 75° from the top dead centre. Neglect the effect of clearance and assume the atmospheric pressure as 1.03 bar.

Solution. Given $D = 240 \text{ mm} = 0.24 \text{ m}$; $L = 360 \text{ mm} = 0.36 \text{ m}$ or $r = L/2 = 0.18 \text{ m}$; $l = 0.6 \text{ m}$; $n = l/r = 0.6/0.18 = 3.33$; $N = 300 \text{ r.p.m.}$ or $\omega = 2\pi \times 300/60 = 31.42 \text{ rad/s}$; $m_R = 160 \text{ kg}$; $p_A = 8 + 1.03 = 9.03 \text{ bar} = 903 \times 10^3 \text{ N/m}^2$; $p_E = -0.75 + 1.03 = 0.28 \text{ bar} = 28 \times 10^3 \text{ N/m}^2$; $F_R = 500 \text{ N}$; $\theta = 75^\circ$

First of all, let us find the piston effort (F_P).

The pressure-volume (p - V) diagram for a steam engine, neglecting clearance, is shown in Fig. 15.13, in which AB represents the admission of steam, BC the expansion and DE the exhaust of steam. The steam is cut-off at point B .

We know that the stroke volume,

$$V_S = \frac{\pi}{4} \times D^2 \times L = \frac{\pi}{4} \times (0.24)^2 \times 0.36 = 0.0163 \text{ m}^3$$

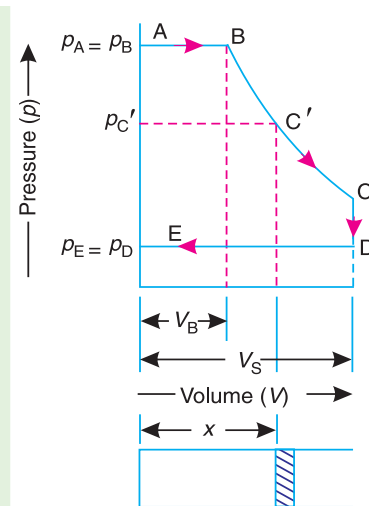

Fig. 15.13

Since the admission of steam is cut-off at 1/3rd of the stroke, therefore volume of steam at cut-off,

$$V_B = V_S / 3 = 0.0163/3 = 0.00543 \text{ m}^3$$

We know that ratio of the lengths of the connecting rod and crank,

$$n = l/r = 0.6/0.18 = 3.33$$

When the crank position is 75° from the top dead centre (*i.e.* when $\theta = 75^\circ$), the displacement of the piston (marked by point C' on the expansion curve BC) is given by

$$x = r \left[(1 - \cos \theta) + \frac{\sin^2 \theta}{2n} \right] = 0.18 \left[1 - \cos 75^\circ + \frac{\sin^2 75^\circ}{2 \times 3.33} \right]$$

$$= 0.1586 \text{ m}$$

$$\therefore V_{C'} = V_S \times \frac{x}{L} = 0.0163 \times \frac{0.1586}{0.36} = 0.0072 \text{ m}^3$$

Since the expansion is hyperbolic (*i.e.* according to the law $pV = \text{constant}$), therefore

$$p_B \cdot V_B = p_{C'} \cdot V_{C'}$$

$$\text{or } p_{C'} = \frac{p_B \times V_B}{V_{C'}} = \frac{903 \times 10^3 \times 0.00543}{0.0072} = 681 \times 10^3 \text{ N/m}^2$$

\therefore Difference of pressures on the two sides of the piston,

$$p = p_{C'} - p_E = 681 \times 10^3 - 28 \times 10^3 = 653 \times 10^3 \text{ N/m}^2$$

We know that net load on the piston,

$$F_L = \frac{\pi}{4} \times D^2 \times p = \frac{\pi}{4} \times (0.24)^2 \times 653 \times 10^3 = 29545 \text{ N}$$

and inertia force on the reciprocating parts,

$$F_I = m_R \cdot \omega^2 \cdot r \left(\cos \theta + \frac{\cos 2\theta}{n} \right)$$

$$= 160 \times (31.42)^2 \times 0.18 \left(\cos 75^\circ + \frac{\cos 150^\circ}{3.33} \right) = -36 \text{ N}$$

\therefore Piston effort,

$$F_P = F_L - F_I + W_R - F_R$$

$$= 29545 - (-36) + 160 \times 9.81 - 500 = 30651 \text{ N}$$

Turning moment on the crankshaft

Let ϕ = Angle of inclination of the connecting rod to the line of stroke.

We know that $\sin \phi = \sin \theta/n = \sin 75^\circ/3.33 = 0.29$

$\therefore \phi = 16.86^\circ$

We know that turning moment on the crankshaft

$$T = \frac{F_P \sin(\theta + \phi)}{\cos \phi} \times r = \frac{30651 \sin(75^\circ + 16.86^\circ)}{\cos 16.86^\circ} \times 0.18 \text{ N-m}$$

$$= 5762 \text{ N-m} \quad \text{Ans.}$$

15.11. Equivalent Dynamical System

In order to determine the motion of a rigid body, under the action of external forces, it is usually convenient to replace the rigid body by two masses placed at a fixed distance apart, in such a way that,

544 • Theory of Machines

1. the sum of their masses is equal to the total mass of the body ;
2. the centre of gravity of the two masses coincides with that of the body ; and
3. the sum of mass moment of inertia of the masses about their centre of gravity is equal to the mass moment of inertia of the body.

When these three conditions are satisfied, then it is said to be an **equivalent dynamical system**. Consider a rigid body, having its centre of gravity at G , as shown in Fig. 15.14.

Let m = Mass of the body,
 k_G = Radius of gyration about its centre of gravity G ,
 m_1 and m_2 = Two masses which form a dynamical equivalent system,
 l_1 = Distance of mass m_1 from G ,
 l_2 = Distance of mass m_2 from G , and
 L = Total distance between the masses m_1 and m_2 .

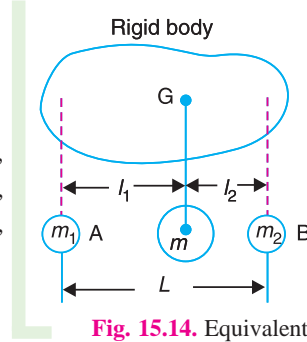

Fig. 15.14. Equivalent dynamical system.

Thus, for the two masses to be dynamically equivalent,

$$m_1 + m_2 = m \quad \dots(i)$$

$$m_1 \cdot l_1 = m_2 \cdot l_2 \quad \dots(ii)$$

and $m_1 (l_1)^2 + m_2 (l_2)^2 = m (k_G)^2 \quad \dots(iii)$

From equations (i) and (ii),

$$m_1 = \frac{l_2 \cdot m}{l_1 + l_2} \quad \dots(iv)$$

and $m_2 = \frac{l_1 \cdot m}{l_1 + l_2} \quad \dots(v)$

Substituting the value of m_1 and m_2 in equation (iii), we have

$$\frac{l_2 \cdot m}{l_1 + l_2} (l_1)^2 + \frac{l_1 \cdot m}{l_1 + l_2} (l_2)^2 = m (k_G)^2 \quad \text{or} \quad \frac{l_1 \cdot l_2 (l_1 + l_2)}{l_1 + l_2} = (k_G)^2$$

$$\therefore l_1 l_2 = (k_G)^2 \quad \dots(vi)$$

This equation gives the essential condition of placing the two masses, so that the system becomes dynamical equivalent. The distance of one of the masses (*i.e.* either l_1 or l_2) is arbitrary chosen and the other distance is obtained from equation (vi).

Note : When the radius of gyration k_G is not known, then the position of the second mass may be obtained by considering the body as a compound pendulum. We have already discussed, that the length of the simple pendulum which gives the same frequency as the rigid body (*i.e.* compound pendulum) is

$$L = \frac{(k_G)^2 + h^2}{h} = \frac{(k_G)^2 + (l_1)^2}{l_1} \quad \dots(\text{Replacing } h \text{ by } l_1)$$

We also know that $l_1 \cdot l_2 = (k_G)^2$

$$\therefore L = \frac{l_1 \cdot l_2 + (l_1)^2}{l_1} = l_2 + l_1$$

This means that the second mass is situated at the **centre of oscillation or percussion** of the body, which is at a distance of $l_2 = (k_G)^2 / l_1$.

15.12. Determination of Equivalent Dynamical System of Two Masses by Graphical Method

Consider a body of mass m , acting at G as shown in Fig. 15.15. This mass m , may be replaced by two masses m_1 and m_2 so that the system becomes dynamical equivalent. The position of mass m_1 may be fixed arbitrarily at A . Now draw perpendicular CG at G , equal in length of the radius of gyration of the body, k_G . Then join AC and draw CB perpendicular to AC intersecting AG produced in B . The point B now fixes the position of the second mass m_2 .

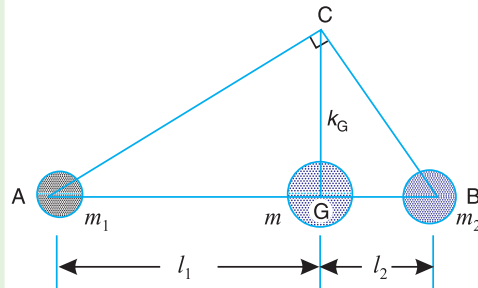

Fig. 15.15. Determination of equivalent dynamical system by graphical method.

A little consideration will show that the triangles ACG and BCG are similar. Therefore,

$$\frac{k_G}{l_1} = \frac{l_2}{k_G} \quad \text{or} \quad (k_G)^2 = l_1 \cdot l_2$$

...(Same as before)

Example 15.15. The connecting rod of a gasoline engine is 300 mm long between its centres. It has a mass of 15 kg and mass moment of inertia of 7000 kg-mm². Its centre of gravity is at 200 mm from its small end centre. Determine the dynamical equivalent two-mass system of the connecting rod if one of the masses is located at the small end centre.

Solution. Given : $l = 300$ mm ; $m = 15$ kg ; $I = 7000$ kg-mm² ;
 $l_1 = 200$ mm

The connecting rod is shown in Fig. 15.16.

Let $k_G =$ Radius of gyration of the connecting rod about an axis passing through its centre of gravity G .

We know that mass moment of inertia (I),

$$7000 = m (k_G)^2 = 15 (k_G)^2$$

$$\therefore (k_G)^2 = 7000/15 = 466.7 \text{ mm}^2 \text{ or } k_G = 21.6 \text{ mm}$$

It is given that one of the masses is located at the small end centre. Let the other mass is placed at a distance l_2 from the centre of gravity G , as shown in Fig. 15.17.

We know that for a dynamical equivalent system,

$$l_1 \cdot l_2 = (k_G)^2$$

$$\therefore l_2 = \frac{(k_G)^2}{l_1} = \frac{466.7}{200} = 2.33 \text{ mm}$$

Let $m_1 =$ Mass placed at the small end centre, and

$m_2 =$ Mass placed at a distance l_2 from the centre of gravity G .

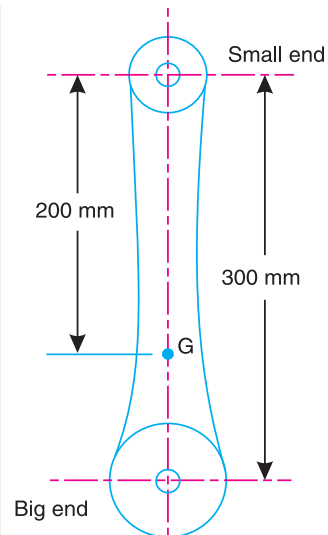

Fig. 15.16

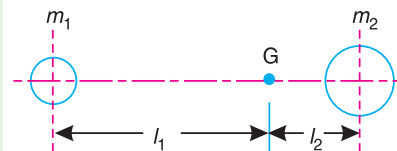

Fig. 15.17

546 • Theory of Machines

We know that

$$m_1 = \frac{l_2 \cdot m}{l_1 + l_2} = \frac{2.33 \times 15}{200 + 2.33} = 0.17 \text{ kg Ans.}$$

and
$$m_2 = \frac{l_1 \cdot m}{l_1 + l_2} = \frac{200 \times 15}{200 + 2.33} = 14.83 \text{ kg Ans.}$$

Example 15.16. A connecting rod is suspended from a point 25 mm above the centre of small end, and 650 mm above its centre of gravity, its mass being 37.5 kg. When permitted to oscillate, the time period is found to be 1.87 seconds. Find the dynamical equivalent system constituted of two masses, one of which is located at the small end centre.

Solution. Given : $h = 650 \text{ mm} = 0.65 \text{ m}$; $l_1 = 650 - 25 = 625 \text{ mm} = 0.625 \text{ m}$; $m = 37.5 \text{ kg}$; $t_p = 1.87 \text{ s}$

First of all, let us find the radius of gyration (k_G) of the connecting rod (considering it is a compound pendulum), about an axis passing through its centre of gravity, G .

We know that for a compound pendulum, time period of oscillation (t_p),

$$1.87 = 2\pi \sqrt{\frac{(k_G)^2 + h^2}{g \cdot h}} \quad \text{or} \quad \frac{1.87}{2\pi} = \sqrt{\frac{(k_G)^2 + (0.65)^2}{9.81 \times 0.65}}$$

Squaring both sides, we have

$$0.0885 = \frac{(k_G)^2 + 0.4225}{6.38}$$

$$(k_G)^2 = 0.0885 \times 6.38 - 0.4225 = 0.1425 \text{ m}^2$$

$$\therefore k_G = 0.377 \text{ m}$$

It is given that one of the masses is located at the small end centre. Let the other mass is located at a distance l_2 from the centre of gravity G , as shown in Fig. 15.19. We know that, for a dynamically equivalent system,

$$l_1 \cdot l_2 = (k_G)^2$$

$$\therefore l_2 = \frac{(k_G)^2}{l_1} = \frac{0.1425}{0.625} = 0.228 \text{ m}$$

Let m_1 = Mass placed at the small end centre A , and

m_2 = Mass placed at a distance l_2 from G , i.e. at B .

We know that, for a dynamically equivalent system,

$$m_1 = \frac{l_2 \cdot m}{l_1 + l_2} = \frac{0.228 \times 37.5}{0.625 + 0.228} = 10 \text{ kg Ans.}$$

and
$$m_2 = \frac{l_1 \cdot m}{l_1 + l_2} = \frac{0.625 \times 37.5}{0.625 + 0.228} = 27.5 \text{ kg Ans.}$$

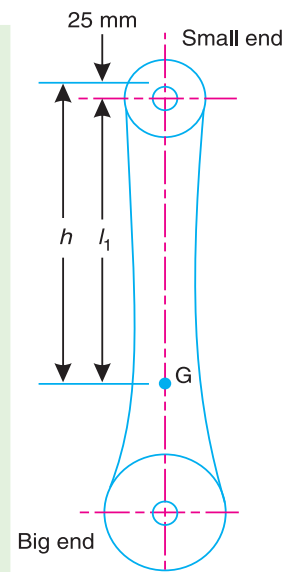

Fig. 15.18

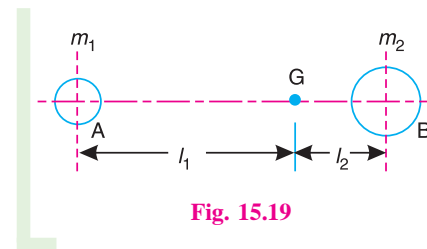

Fig. 15.19

Example 15.17. The following data relate to a connecting rod of a reciprocating engine:

Mass = 55 kg; Distance between bearing centres = 850 mm; Diameter of small end bearing = 75 mm; Diameter of big end bearing = 100 mm; Time of oscillation when the connecting rod is suspended from small end = 1.83 s; Time of oscillation when the connecting rod is suspended from big end = 1.68 s.

Determine: **1.** the radius of gyration of the rod about an axis passing through the centre of gravity and perpendicular to the plane of oscillation; **2.** the moment of inertia of the rod about the same axis; and **3.** the dynamically equivalent system for the connecting rod, constituted of two masses, one of which is situated at the small end centre.

Solution. Given : $m = 55 \text{ kg}$; $l = 850 \text{ mm} = 0.85 \text{ m}$; $d_1 = 75 \text{ mm} = 0.075 \text{ m}$; $d_2 = 100 \text{ mm} = 0.1 \text{ m}$; $t_{p1} = 1.83 \text{ s}$; $t_{p2} = 1.68 \text{ s}$

First of all, let us find the lengths of the equivalent simple pendulum when suspended

- (a) from the top of small end bearing; and
- (b) from the top of big end bearing.

Let L_1 = Length of equivalent simple pendulum when suspended from the top of small end bearing,

L_2 = Length of equivalent simple pendulum when suspended from the top of big end bearing,

h_1 = Distance of centre of gravity, G , from the top of small end bearing, and

h_2 = Distance of centre of gravity, G , from the top of big end bearing.

We know that for a simple pendulum

$$t_{p1} = 2\pi \sqrt{\frac{L_1}{g}} \quad \text{or} \quad \left(\frac{t_{p1}}{2\pi}\right)^2 = \frac{L_1}{g}$$

$$\therefore L_1 = g \left(\frac{t_{p1}}{2\pi}\right)^2 = 9.81 \left(\frac{1.83}{2\pi}\right)^2 = 0.832 \text{ m}$$

$$\text{Similarly, } L_2 = g \left(\frac{t_{p2}}{2\pi}\right)^2 = 9.81 \left(\frac{1.68}{2\pi}\right)^2 = 0.7 \text{ m}$$

1. Radius of gyration of the rod about an axis passing through the centre of gravity and perpendicular to the plane of oscillation

Let k_G = Required radius of gyration of the rod.

We know that the length of equivalent simple pendulum,

$$L = \frac{(k_G)^2 + h^2}{h} \quad \text{or} \quad (k_G)^2 = Lh - h^2 = h(L - h)$$

\therefore When the rod is suspended from the top of small end bearing,

$$(k_G)^2 = h_1(L_1 - h_1) \tag{i}$$

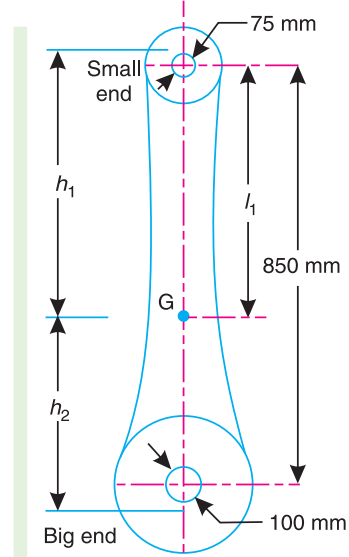

Fig. 15.20

...(Squaring both sides)

548 • Theory of Machines

and when the rod is suspended from the top of big end bearing,

$$(k_G)^2 = h_2 (L_2 - h_2) \quad \dots(ii)$$

Also, from the geometry of the Fig. 15.20,

$$h_1 + h_2 = \frac{d_1}{2} + l + \frac{d_2}{2} = \frac{0.075}{2} + 0.85 + \frac{0.1}{2} = 0.9375 \text{ m}$$

$$\therefore h_2 = 0.9375 - h_1 \quad \dots(iii)$$

From equations (i) and (ii),

$$h_1 (L_1 - h_1) = h_2 (L_2 - h_2)$$

Substituting the value of h_2 from equation (iii),

$$\begin{aligned} h_1 (0.832 - h_1) &= (0.9375 - h_1) [0.7 - (0.9375 - h_1)] \\ 0.832 h_1 - (h_1)^2 &= -0.223 + 1.175 h_1 - (h_1)^2 \\ 0.343 h_1 &= 0.223 \text{ or } h_1 = 0.223 / 0.343 = 0.65 \text{ m} \end{aligned}$$

Now from equation (i),

$$(k_G)^2 = 0.65 (0.832 - 0.65) = 0.1183 \text{ or } k_G = 0.343 \text{ m Ans.}$$

2. Moment of inertia of the rod

We know that moment of inertia of the rod,

$$I = m (k_G)^2 = 55 \times 0.1183 = 6.51 \text{ kg-m}^2 \text{ Ans.}$$

3. Dynamically equivalent system for the rod

Since one of the masses (m_1) is situated at the centre of small end bearing, therefore its distance from the centre of gravity, G , is

$$l_1 = h_1 - 0.075 / 2 = 0.65 - 0.0375 = 0.6125 \text{ m}$$

Let

$$m_2 = \text{Magnitude of the second mass, and}$$

$$l_2 = \text{Distance of the second mass from the centre of gravity, } G, \text{ towards big end bearing.}$$

For a dynamically equivalent system,

$$l_1 l_2 = (k_G)^2 \text{ or } l_2 = \frac{(k_G)^2}{l_1} = \frac{0.1183}{0.6125} = 0.193 \text{ m}$$

$$\text{We know that } m_1 = \frac{l_2 m}{l_1 + l_2} = \frac{0.193 \times 55}{0.6125 + 0.193} = 13.18 \text{ kg Ans.}$$

and

$$m_2 = \frac{l_1 m}{l_1 + l_2} = \frac{0.6125 \times 55}{0.6125 + 0.193} = 41.82 \text{ kg Ans.}$$

15.13. Correction Couple to be Applied to Make Two Mass System Dynamically Equivalent

In Art. 15.11, we have discussed the conditions for equivalent dynamical system of two bodies. A little consideration will show that when two masses are placed arbitrarily*, then the condi-

* When considering the inertia forces on the connecting rod in a mechanism, we replace the rod by two masses arbitrarily. This is discussed in Art. 15.14.

tions (i) and (ii) as given in Art. 15.11 will only be satisfied. But the condition (iii) is not possible to satisfy. This means that the mass moment of inertia of these two masses placed arbitrarily, will differ than that of mass moment of inertia of the rigid body.

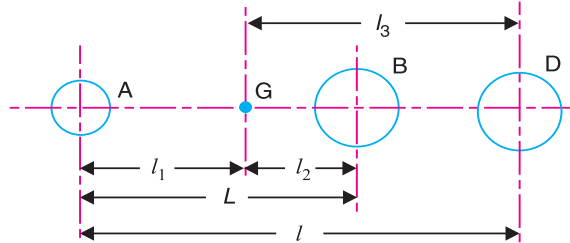

Fig. 15.21. Correction couple to be applied to make the two-mass system dynamically equivalent.

Consider two masses, one at A and the other at D be placed arbitrarily, as shown in Fig. 15.21.

- Let
- l_3 = Distance of mass placed at D from G ,
 - I_1 = New mass moment of inertia of the two masses;
 - k_1 = New radius of gyration;
 - α = Angular acceleration of the body;
 - I = Mass moment of inertia of a dynamically equivalent system;
 - k_G = Radius of gyration of a dynamically equivalent system.

We know that the torque required to accelerate the body,

$$T = I.\alpha = m (k_G)^2 \alpha \quad \dots(i)$$

Similarly, the torque required to accelerate the two-mass system placed arbitrarily,

$$T_1 = I_1.\alpha = m (k_1)^2 \alpha \quad \dots(ii)$$

\therefore Difference between the torques required to accelerate the two-mass system and the torque required to accelerate the rigid body,

$$T' = T_1 - T = m (k_1)^2 \alpha - m (k_G)^2 \alpha = m [(k_1)^2 - (k_G)^2] \alpha \quad \dots(iv)$$

The difference of the torques T' is known as **correction couple**. This couple must be applied, when the masses are placed arbitrarily to make the system dynamical equivalent. This, of course, will satisfy the condition (iii) of Art. 15.11.

Note: We know that $(k_G)^2 = l_1.l_2$, and $(k_1)^2 = l_1.l_3$

$$\therefore \text{Correction couple, } T' = m (l_1.l_3 - l_1.l_2) \alpha = m.l_1 (l_3 - l_2) \alpha$$

But $l_3 - l_2 = l - L$

$$\therefore T' = m.l_1 (l - L) \alpha$$

where

l = Distance between the two arbitrarily masses, and

L = Distance between the two masses for a true dynamically equivalent system. It is the equivalent length of a simple pendulum when a body is suspended from an axis which passes through the position of mass m , and perpendicular to the plane of rotation of the two mass system.

$$= \frac{(k_G)^2 + (l_1)^2}{l_1}$$

550 • Theory of Machines

Example 15.18. A connecting rod of an I.C. engine has a mass of 2 kg and the distance between the centre of gudgeon pin and centre of crank pin is 250 mm. The C.G. falls at a point 100 mm from the gudgeon pin along the line of centres. The radius of gyration about an axis through the C.G. perpendicular to the plane of rotation is 110 mm. Find the equivalent dynamical system if only one of the masses is located at gudgeon pin.

If the connecting rod is replaced by two masses, one at the gudgeon pin and the other at the crank pin and the angular acceleration of the rod is 23 000 rad/s² clockwise, determine the correction couple applied to the system to reduce it to a dynamically equivalent system.

Solution. Given : $m = 2 \text{ kg}$; $l = 250 \text{ mm} = 0.25 \text{ m}$; $l_1 = 100 \text{ mm} = 0.1 \text{ m}$; $k_G = 110 \text{ mm} = 0.11 \text{ m}$; $\alpha = 23\,000 \text{ rad/s}^2$

Equivalent dynamical system

It is given that one of the masses is located at the gudgeon pin. Let the other mass be located at a distance l_2 from the centre of gravity. We know that for an equivalent dynamical system,

$$l_1 \cdot l_2 = (k_G)^2 \quad \text{or} \quad l_2 = \frac{(k_G)^2}{l_1} = \frac{(0.11)^2}{0.1} = 0.121 \text{ m}$$

Let $m_1 =$ Mass placed at the gudgeon pin, and
 $m_2 =$ Mass placed at a distance l_2 from C.G.

We know that $m_1 = \frac{l_2 \cdot m}{l_1 + l_2} = \frac{0.121 \times 2}{0.1 + 0.121} = 1.1 \text{ kg}$ **Ans.**

and $m_2 = \frac{l_1 \cdot m}{l_1 + l_2} = \frac{0.1 \times 2}{0.1 + 0.121} = 0.9 \text{ kg}$ **Ans.**

Correction couple

Since the connecting rod is replaced by two masses located at the two centres (*i.e.* one at the gudgeon pin and the other at the crank pin), therefore,

$$l = 0.1 \text{ m, and } l_3 = l - l_1 = 0.25 - 0.1 = 0.15 \text{ m}$$

Let $k_1 =$ New radius of gyration.

We know that $(k_1)^2 = l_1 \cdot l_3 = 0.1 \times 0.15 = 0.015 \text{ m}^2$

∴ Correction couple,

$$T' = m(k_1^2 - k_G^2) \alpha = 2[0.015 - (0.11)^2] 23\,000 = 133.4 \text{ N-m}$$
 Ans.

Note : Since T' is positive, therefore, the direction of correction couple is same as that of angular acceleration *i.e.* clockwise.

15.14. Inertia Forces in a Reciprocating Engine, Considering the Weight of Connecting Rod

In a reciprocating engine, let OC be the crank and PC , the connecting rod whose centre of gravity lies at G . The inertia forces in a reciprocating engine may be obtained graphically as discussed below:

1. First of all, draw the acceleration diagram $OCQN$ by Klien's construction. We know that the acceleration of the piston P with respect to O ,

$$a_{pO} = a_p = \omega^2 \times NO,$$

acting in the direction from N to O . Therefore, the inertia force F_I of the reciprocating parts will act in the opposite direction as shown in Fig. 15.22.

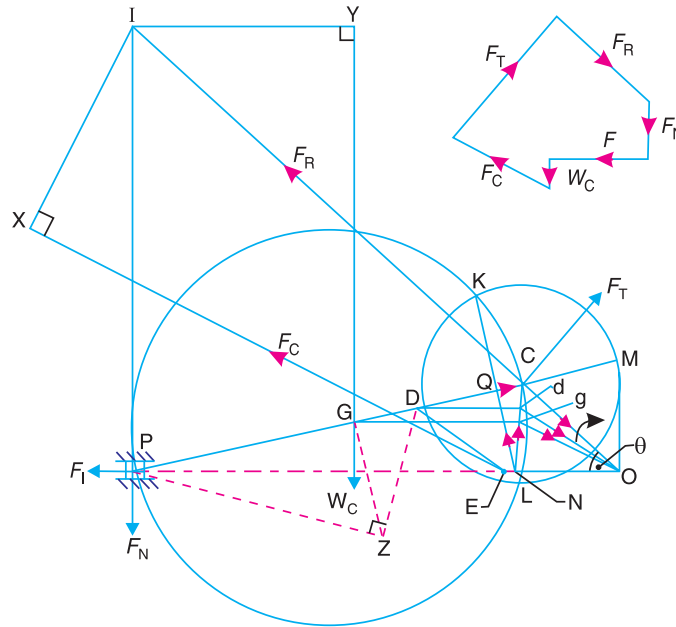

Fig. 15.22. Inertia forces in reciprocating engine, considering the weight of connecting rod.

2. Replace the connecting rod by dynamically equivalent system of two masses as discussed in Art. 15.12. Let one of the masses be arbitrarily placed at P . To obtain the position of the other mass, draw GZ perpendicular to CP such that $GZ = k$, the radius of gyration of the connecting rod. Join PZ and from Z draw perpendicular to DZ which intersects CP at D . Now, D is the position of the second mass.

Note: The position of the second mass may also be obtained from the equation,

$$GP \times GD = k^2$$

3. Locate the points G and D on NC which is the acceleration image of the connecting rod. This is done by drawing parallel lines from G and D to the line of stroke PO . Let these parallel lines intersect NC at g and d respectively. Join gO and dO . Therefore, acceleration of G with respect to O , in the direction from g to O ,

$$a_{GO} = a_G = \omega^2 \times gO$$

and acceleration of D with respect to O , in the direction from d to O ,

$$a_{DO} = a_D = \omega^2 \times dO$$

4. From D , draw DE parallel to dO which intersects the line of stroke PO at E . Since the accelerating forces on the masses at P and D intersect at E , therefore their resultant must also pass through E . But their resultant is equal to the accelerating force on the rod, so that the line of action of the accelerating force on the rod, is given by a line drawn through E and parallel to gO , in the direction from g to O . The inertia force of the connecting rod F_C therefore acts through E and in the opposite direction as shown in Fig. 15.22. The inertia force of the connecting rod is given by

$$F_C = m_C \times \omega^2 \times gO \quad \dots(i)$$

where

$$m_C = \text{Mass of the connecting rod.}$$

A little consideration will show that the forces acting on the connecting rod are :

- (a) Inertia force of the reciprocating parts (F_I) acting along the line of stroke PO ,

552 • Theory of Machines

- (b) The side thrust between the crosshead and the guide bars (F_N) acting at P and right angles to line of stroke PO ,
- (c) The weight of the connecting rod ($W_C = m_C \cdot g$),
- (d) Inertia force of the connecting rod (F_C),
- (e) The radial force (F_R) acting through O and parallel to the crank OC ,
- (f) The force (F_T) acting perpendicular to the crank OC .



Radial engines of a motor cycle.

Now, produce the lines of action of F_R and F_N to intersect at a point I , known as instantaneous centre. From I draw $I X$ and $I Y$, perpendicular to the lines of action of F_C and W_C . Taking moments about I , we have

$$F_T \times IC = F_I \times IP + F_C \times IX + W_C \times IY \quad \dots(ii)$$

The value of F_T may be obtained from this equation and from the force polygon as shown in Fig. 15.22, the forces F_N and F_R may be calculated. We know that, torque exerted on the crankshaft to overcome the inertia of the moving parts = $F_T \times OC$

Note : When the mass of the reciprocating parts is neglected, then F_I is zero.

15.15. Analytical Method for Inertia Torque

The effect of the inertia of the connecting rod on the crankshaft torque may be obtained as discussed in the following steps:

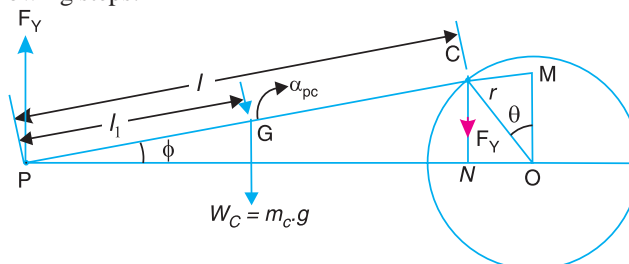

Fig. 15.23. Analytical method for inertia torque.

1. The mass of the connecting rod (m_C) is divided into two masses. One of the mass is placed at the crosshead pin P and the other at the crankpin C as shown in Fig. 15.23, so that the centre of gravity of these two masses coincides with the centre of gravity of the rod G .

2. Since the inertia force due to the mass at C acts radially outwards along the crank OC , therefore the mass at C has no effect on the crankshaft torque.

3. The inertia force of the mass at P may be obtained as follows:

- Let
- m_C = Mass of the connecting rod,
 - l = Length of the connecting rod,
 - l_1 = Length of the centre of gravity of the connecting rod from P .

∴ Mass of the connecting rod at P ,

$$= \frac{l - l_1}{l} \times m_C$$

The mass of the reciprocating parts (m_R) is also acting at P . Therefore,

Total equivalent mass of the reciprocating parts acting at P

$$= m_R + \frac{l - l_1}{l} \times m_C$$

∴ Total inertia force of the equivalent mass acting at P ,

$$F_1 = \left(m_R + \frac{l - l_1}{l} \times m_C \right) a_R \quad \dots(i)$$

where

a_R = Acceleration of the reciprocating parts

$$= \omega^2 \cdot r \left(\cos \theta + \frac{\cos 2\theta}{n} \right)$$

$$\therefore F_1 = \left[m_R + \frac{l - l_1}{l} \times m_C \right] \omega^2 \cdot r \left(\cos \theta + \frac{\cos 2\theta}{n} \right)$$

and corresponding torque exerted on the crank shaft,

$$T_1 = F_1 \times OM = F_1 \cdot r \left(\sin \theta + \frac{\sin 2\theta}{2\sqrt{n^2 - \sin^2 \theta}} \right) \quad \dots(ii)$$

Note : Usually the value of OM is measured by drawing the perpendicular from O on PO which intersects PC produced at M .

4. In deriving the equation (ii) of the torque exerted on the crankshaft, it is assumed that one of the two masses is placed at C and the other at P . This assumption does not satisfy the condition for kinetically equivalent system of a rigid bar. Hence to compensate for it, a correcting torque is necessary whose value is given by

$$T' = m_C \left[(k_1)^2 - (k_G)^2 \right] \alpha_{PC} = m_C \cdot l_1 (l - L) \alpha_{PC}$$

where

L = Equivalent length of a simple pendulum when swung about an axis through P

$$= \frac{(k_G)^2 + (l_1)^2}{l_1}$$

α_{PC} = Angular acceleration of the connecting rod PC .

$$= \frac{-\omega^2 \sin \theta}{n} \quad \dots(\text{From Art. 15.9})$$

The correcting torque T' may be applied to the system by two equal and opposite forces F_Y acting through P and C . Therefore,

$$F_Y \times PN = T' \quad \text{or} \quad F_Y = T'/PN$$

and corresponding torque on the crankshaft,

$$T_C = F_Y \times NO = \frac{T'}{PN} \times NO \quad \dots(iii)$$

We know that,

$$NO = OC \cos \theta = r \cos \theta$$

and

$$PN = PC \cos \phi = l \cos \phi$$

554 • Theory of Machines

$$\begin{aligned} \therefore \frac{NO}{PN} &= \frac{r \cos \theta}{l \cos \phi} = \frac{\cos \theta}{n \cos \phi} && \dots \left(\because n = \frac{l}{r} \right) \\ &= \frac{\cos \theta}{n \sqrt{1 - \frac{\sin^2 \theta}{n^2}}} = \frac{\cos \theta}{\sqrt{n^2 - \sin^2 \theta}} && \dots \left(\because \cos \phi = \sqrt{1 - \frac{\sin^2 \theta}{n^2}} \right) \end{aligned}$$

Since $\sin^2 \theta$ is very small as compared to n^2 , therefore neglecting $\sin^2 \theta$, we have

$$\frac{NO}{PN} = \frac{\cos \theta}{n}$$

Substituting this value in equation (iii), we have

$$\begin{aligned} T_C &= T' \times \frac{\cos \theta}{n} = m_C \times l_1 (l - L) \alpha_{PC} \times \frac{\cos \theta}{n} \\ &= -m_C \times l_1 (l - L) \frac{\omega^2 \sin \theta}{n} \times \frac{\cos \theta}{n} && \dots \left(\because \alpha_{PC} = \frac{-\omega^2 \sin \theta}{n} \right) \\ &= -m_C \times l_1 (l - L) \frac{\omega^2 \sin 2\theta}{2 n^2} && \dots (\because 2 \sin \theta \cos \theta = \sin 2\theta) \end{aligned}$$

5. The equivalent mass of the rod acting at C,

$$m_2 = m_C \times \frac{l_1}{l}$$

\therefore Torque exerted on the crank shaft due to mass m_2 ,

$$\begin{aligned} T_W &= -m_2 \times g \times NO = -m_C \times g \times \frac{l_1}{l} \times NO = -m_C \times g \times \frac{l_1}{l} \times r \cos \theta \\ &&& \dots (\because NO = r \cos \theta) \\ &= -m_C \times g \times \frac{l_1}{n} \times \cos \theta && \dots (\because l/r = n) \end{aligned}$$

6. The total torque exerted on the crankshaft due to the inertia of the moving parts is the algebraic sum of T_I , T_C and T_W .

Example 15.19. The crank and connecting rod lengths of an engine are 125 mm and 500 mm respectively. The mass of the connecting rod is 60 kg and its centre of gravity is 275 mm from the crosshead pin centre, the radius of gyration about centre of gravity being 150 mm.

If the engine speed is 600 r.p.m. for a crank position of 45° from the inner dead centre, determine, using Klien's or any other construction 1. the acceleration of the piston; 2. the magnitude, position and direction of inertia force due to the mass of the connecting rod.

Solution. Given : $r = OC = 125$ mm ; $l = PC = 500$ mm ; $m_C = 60$ kg ; $PG = 275$ mm ; $m_C = 60$ kg ; $PG = 275$ mm ; $k_G = 150$ mm ; $N = 600$ r.p.m. or $\omega = 2\pi \times 600/60 = 62.84$ rad/s ; $\theta = 45^\circ$

1. Acceleration of the piston

Let a_p = Acceleration of the piston.

First of all, draw the configuration diagram OCP , as shown in Fig. 15.24, to some suitable scale, such that

$$OC = r = 125 \text{ mm} ; PC = l = 500 \text{ mm} ; \text{ and } \theta = 45^\circ.$$

Now, draw the Klien's acceleration diagram $OCQN$, as shown in Fig. 15.24, in the same manner as already discussed. By measurement,

$$NO = 90 \text{ mm} = 0.09 \text{ m}$$

∴ Acceleration of the piston,

$$a_p = \omega^2 \times NO = (62.84)^2 \times 0.09 = 355.4 \text{ m/s}^2 \text{ Ans.}$$

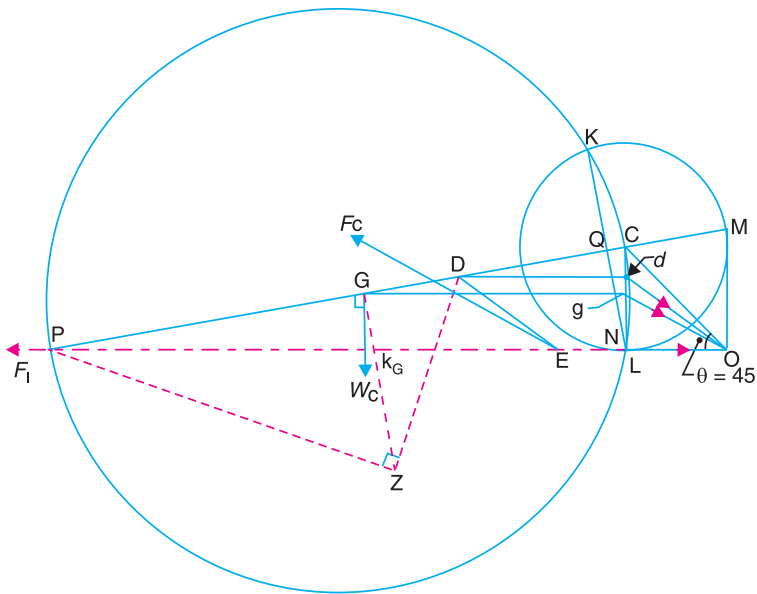

Fig. 15.24

2. The magnitude, position and direction of inertia force due to the mass of the connecting rod

The magnitude, position and direction of the inertia force may be obtained as follows:

(i) Replace the connecting rod by dynamical equivalent system of two masses, assuming that one of the masses is placed at P and the other mass at D . The position of the point D is obtained as discussed in Art. 15.12.

(ii) Locate the points G and D on NC which is the acceleration image of the connecting rod. Let these points are g and d on NC . Join gO and dO . By measurement,

$$gO = 103 \text{ mm} = 0.103 \text{ m}$$

∴ Acceleration of G , $a_G = \omega^2 \times gO$, acting in the direction from g to O .

(iii) From point D , draw DE parallel to dO . Now E is the point through which the inertia force of the connecting rod passes. The magnitude of the inertia force of the connecting rod is given by

$$F_C = m_C \times \omega^2 \times gO = 60 \times (62.84)^2 \times 0.103 = 24\,400 \text{ N} = 24.4 \text{ kN} \text{ Ans.}$$

(iv) From point E , draw a line parallel to gO , which shows the position of the inertia force of the connecting rod and acts in the opposite direction of gO .

Example 15.20. The following data refer to a steam engine:

Diameter of piston = 240 mm; stroke = 600 mm; length of connecting rod = 1.5 m; mass of reciprocating parts = 300 kg; mass of connecting rod = 250 kg; speed = 125 r.p.m; centre of gravity of connecting rod from crank pin = 500 mm; radius of gyration of the connecting rod about an axis through the centre of gravity = 650 mm.

556 • Theory of Machines

Determine the magnitude and direction of the torque exerted on the crankshaft when the crank has turned through 30° from inner dead centre.

Solution. Given : $D = 240 \text{ mm} = 0.24 \text{ m}$; $L = 600 \text{ mm}$ or $r = L/2 = 300 \text{ mm} = 0.3 \text{ m}$;
 $l = 1.5 \text{ m}$; $m_R = 300 \text{ kg}$; $m_C = 250 \text{ kg}$; $N = 125 \text{ r.p.m.}$ or $\omega = 2\pi \times 125/60 = 13.1 \text{ rad/s}$;
 $GC = 500 \text{ mm} = 0.5 \text{ m}$; $k_G = 650 \text{ mm} = 0.65 \text{ m}$; $\theta = 30^\circ$

The inertia torque on the crankshaft may be determined by graphical method or analytical method as discussed below:

1. Graphical method

First of all, draw the configuration diagram OCP , as shown in Fig. 15.25, to some suitable scale, such that

$$OC = r = 300 \text{ mm} ; PC = l = 1.5 \text{ m} ; \text{ and angle } POC = \theta = 30^\circ .$$

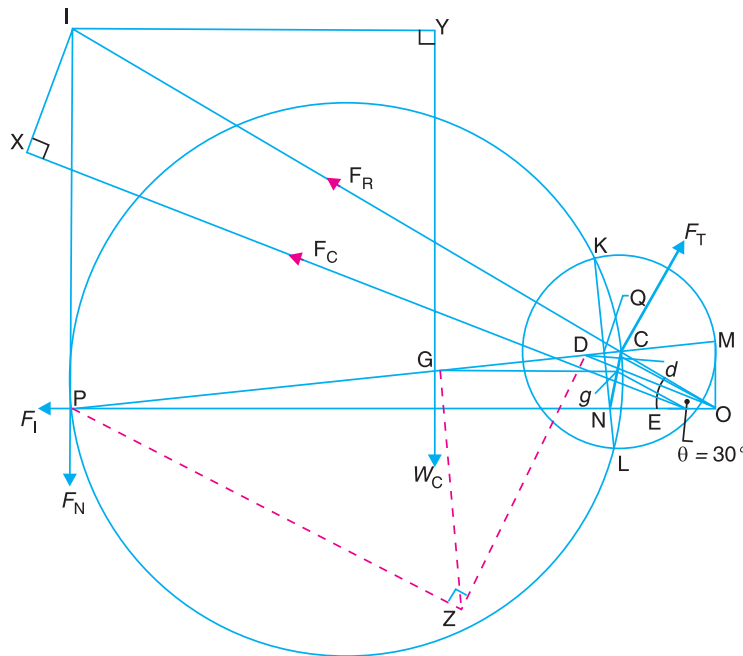

Fig. 15.25

Now draw the Klien's acceleration diagram $OCQN$, as shown in Fig. 15.25, and complete the figure in the similar manner as discussed in Art. 15.14.

By measurement; $NO = 0.28 \text{ m}$; $gO = 0.28 \text{ m}$; $IP = 1.03 \text{ m}$; $IX = 0.38 \text{ m}$; $IY = 0.98 \text{ m}$, and $IC = 1.7 \text{ m}$.

We know that inertia force of reciprocating parts,

$$F_I = m_R \times \omega^2 \times NO = 300 \times (13.1)^2 \times 0.28 = 14\,415 \text{ N}$$

and inertia force of connecting rod,

$$F_C = m_C \times \omega^2 \times gO = 250 \times (13.1)^2 \times 0.28 = 12\,013 \text{ N}$$

Let

$$F_T = \text{Force acting perpendicular to the crank } OC.$$

Taking moments about point I ,

$$F_T \times IC = F_I \times IP + W_C \times IY + F_C \times IX$$

$$F_T \times 1.7 = 14\,415 \times 1.03 + 250 \times 9.81 \times 0.98 + 12013 \times 0.38 = 21816$$

$$\therefore F_T = 2.816/1.7 = 12\,833 \text{ N} \quad \dots(\because W_C = m_C \cdot g)$$

We know that torque exerted on the crankshaft

$$= F_T \times r = 12\,833 \times 0.3 = 3850 \text{ N-m Ans.}$$

2. Analytical method

We know that the distance of centre of gravity (G) of the connecting rod from P , i.e.,

$$l_1 = l - GC = 1.5 - 0.5 = 1 \text{ m}$$

\therefore Inertia force due to total mass of the reciprocating parts at P ,

$$\begin{aligned} F_I &= \left(m_R + \frac{l - l_1}{l} \times m_C \right) \omega^2 \cdot r \left(\cos \theta + \frac{\cos 2\theta}{5} \right) \\ &= \left(300 + \frac{1.5 - 1}{1.5} \times 250 \right) \times (13.1)^2 \times 0.3 \left(\cos 30^\circ + \frac{\cos 60^\circ}{5} \right) = 19\,064 \text{ N} \\ &\quad \dots \left[\because n = \frac{l}{r} = \frac{1.5}{0.3} = 5 \right] \end{aligned}$$

\therefore Corresponding torque due to F_I ,

$$\begin{aligned} T_I &= F_I \times OM = F_I \cdot r \left(\sin \theta + \frac{\sin 2\theta}{2\sqrt{n^2 - \sin^2 \theta}} \right) \\ &= 19\,064 \times 0.3 \left(\sin 30^\circ + \frac{\sin 60^\circ}{2\sqrt{5^2 - \sin^2 30^\circ}} \right) \\ &= 5719.2 \times 0.587 = 3357 \text{ N-m (anticlockwise)} \end{aligned}$$

Equivalent length of a simple pendulum when swung about an axis through P ,

$$L = \frac{(k_G)^2 + (l_1)^2}{l_1} = \frac{(0.65)^2 + 1^2}{1} = 1.42 \text{ m}$$

\therefore Correcting torque,

$$\begin{aligned} T_C &= m_C \cdot l_1 (l - L) \left[\frac{\omega^2 \sin 2\theta}{2n^2} \right] \\ &= 250 \times 1 (1.5 - 1.42) \left[\frac{(13.1)^2 \sin 60^\circ}{2 \times 5^2} \right] = 59.5 \text{ N-m (anticlockwise)} \end{aligned}$$

Torque due to the weight of the connecting rod at C ,

$$\begin{aligned} T_W &= W_C \times \frac{l_1}{n} \times \cos \theta = m_C \times g \times \frac{l_1}{n} \times \cos \theta \\ &= 250 \times 9.81 \times \frac{1}{5} \times \cos 30^\circ = 424.8 \text{ N-m (anticlockwise)} \end{aligned}$$

\therefore Total torque exerted on the crankshaft,

$$\begin{aligned} &= T_I + T_C + T_W \\ &= 3357 + 59.5 + 424.8 = 3841.3 \text{ N-m (anticlockwise) Ans.} \end{aligned}$$

Note: The slight difference in results arrived at by the above two methods is mainly due to error in measurement in graphical method.

Example 15.21. A vertical engine running at 1200 r.p.m. with a stroke of 110 mm, has a connecting rod 250 mm between centres and mass 1.25 kg. The mass centre of the connecting rod is 75 mm from the big end centre and when suspended as a pendulum from the gudgeon pin axis makes 21 complete oscillations in 20 seconds.

1. Calculate the radius of gyration of the connecting rod about an axis through its mass centre.

2. When the crank is at 40° from the top dead centre and the piston is moving downwards, find analytically, the acceleration of the piston and the angular acceleration of the connecting rod. Hence find the inertia torque exerted on the crankshaft. To make the two-mass system to be dynamically equivalent to the connecting rod, necessary correction torque has to be applied and since the engine is vertical, gravity effects are to be considered.

Solution. Given : $N = 1200$ r.p.m. or $\omega = 2\pi \times 1200/60 = 125.7$ rad/s ;
 $L = 110$ mm or $r = L/2 = 55$ mm = 0.055 m ; $l = PC = 250$ mm = 0.25 m ;
 $m_C = 1.25$ kg ; $CG = 75$ mm = 0.075 m ; $\theta = 40^\circ$

The configuration diagram of the engine is shown in Fig. 15.26.

1. Radius of gyration of the connecting rod about an axis through its mass centre

Let k_G = Radius of gyration of the connecting rod about an axis through its mass centre,
 l_1 = Distance of the centre of gravity from the point of suspension = PG
 $= 250 - 75 = 175$ mm = 0.175 m

Since the connecting rod makes 21 complete oscillations in 20 seconds, therefore frequency of oscillation,

$$n = \frac{21}{20} = 1.05 \text{ Hz}$$

We know that for a compound pendulum, frequency of oscillation,

$$n = \frac{1}{2\pi} \sqrt{\frac{g l_1}{(k_G)^2 + (l_1)^2}} \quad \text{or} \quad n^2 = \frac{1}{4\pi^2} \times \frac{g l_1}{(k_G)^2 + (l_1)^2}$$

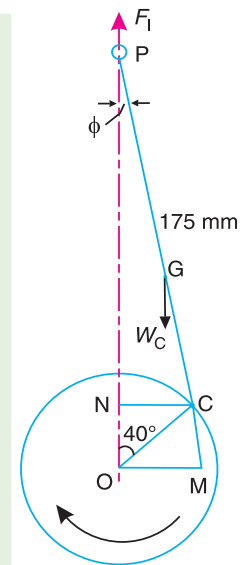

Fig. 15.26

...(Squaring both sides)

and $(k_G)^2 = \frac{g l_1}{4\pi^2 n^2} - (l_1)^2 = \frac{9.81 \times 0.175}{4\pi^2 \times (1.05)^2} - (0.175)^2 = 0.0088 \text{ m}^2$

$\therefore k_G = 0.094 \text{ m} = 94 \text{ mm}$ **Ans.**

2. Acceleration of the piston

We know that acceleration of the piston,

$$a_p = \omega^2 \cdot r \left(\cos \theta + \frac{\cos 2\theta}{n} \right) = (125.7)^2 \cdot 0.055 \left(\cos 40^\circ + \frac{\cos 80^\circ}{0.25/0.055} \right)$$

$$= 698.7 \text{ m/s}^2 \text{ Ans.} \quad \dots(\because n = l/r)$$

Angular acceleration of the connecting rod

We know that mass of the connecting rod at P,

$$\alpha_{PC} = \frac{-\omega^2 \sin \theta}{n} = \frac{-(125.7)^2 \sin 40^\circ}{0.25/0.055} = -2234.4 \text{ rad/s}^2 \text{ Ans.}$$

Inertia torque exerted on the crankshaft

We know that mass of the connecting rod at P ,

$$m_1 = \frac{l - l_1}{l} \times m_C = \frac{0.25 - 0.175}{0.25} \times 1.25 = 0.375 \text{ kg}$$

∴ Vertical inertia force,

$$F_1 = m_1 \cdot a_P = 0.375 \times 698.7 = 262 \text{ N}$$

and corresponding torque due to F_1 ,

$$\begin{aligned} T_1 &= -F_1 \times OM = -262 \times 0.0425 = -11.135 \text{ N-m} \\ &= 11.135 \text{ N-m (anticlockwise)} \quad \dots(\text{By measurement, } OM = 0.0425 \text{ m}) \end{aligned}$$

We know that the equivalent length of a simple pendulum when swung about an axis passing through P ,

$$L = \frac{(k_G)^2 + (l_1)^2}{l_1} = \frac{(0.094)^2 + (0.175)^2}{0.175} = 0.225 \text{ m}$$

∴ Correction couple,

$$T' = -m_C \cdot l_1 (l - L) \alpha_{PC} = -1.25 \times 0.175 (0.25 - 0.225) 2234.4 = -12.22 \text{ N-m}$$

Corresponding torque on the crankshaft,

$$T_C = \frac{T' \cos \theta}{n} = \frac{-12.22 \times \cos 40^\circ}{0.25/0.055} = -2.06 \text{ N-m} = 2.06 \text{ N-m (anticlockwise)}$$

Torque due to the mass at P ,

$$T_P = m_1 \times g \times OM = 0.375 \times 9.81 \times 0.0425 = 0.156 \text{ N-m (clockwise)}$$

Equivalent mass of the connecting rod at C ,

$$m_2 = m_C \times \frac{l_1}{l} = 1.25 \times \frac{0.175}{0.25} = 0.875 \text{ kg}$$

Torque due to mass at C ,

$$\begin{aligned} T_W &= m_2 \times g \times NC = 0.875 \times 9.81 \times 0.035 = 0.3 \text{ N-m (clockwise)} \\ &\dots(\text{By measurement, } NC = 0.035 \text{ m}) \end{aligned}$$

∴ Inertia torque exerted on the crankshaft

$$\begin{aligned} &= T_1 + T_C - T_P - T_W \\ &= 11.135 + 2.06 - 0.156 - 0.3 = 12.739 \text{ N-m (anticlockwise) Ans.} \end{aligned}$$

Example 15.22. The connecting rod of an internal combustion engine is 225 mm long and has a mass 1.6 kg. The mass of the piston and gudgeon pin is 2.4 kg and the stroke is 150 mm. The cylinder bore is 112.5 mm. The centre of gravity of the connection rod is 150 mm from the small end. Its radius of gyration about the centre of gravity for oscillations in the plane of swing of the connecting rod is 87.5 mm. Determine the magnitude and direction of the resultant force on the crank pin when the crank is at 40° and the piston is moving away from inner dead centre under an effective gas pressure of 1.8 MN/m^2 . The engine speed is 1200 r.p.m.

Solution. Given : $l = PC = 225 \text{ mm} = 0.225 \text{ m}$; $m_C = 1.6 \text{ kg}$; $m_R = 2.4 \text{ kg}$; $L = 150 \text{ mm}$ or $r = L/2 = 75 \text{ mm} = 0.075 \text{ m}$; $D = 112.5 \text{ mm} = 0.1125 \text{ m}$; $PG = 150 \text{ mm}$; $k_G = 87.5 \text{ mm} = 0.0875 \text{ m}$; $\theta = 40^\circ$; $p = 1.8 \text{ MN/m}^2 = 1.8 \times 10^6 \text{ N/m}^2$; $N = 1200 \text{ r.p.m.}$ or $\omega = 2\pi \times 1200/60 = 125.7 \text{ rad/s}$

560 • Theory of Machines

First of all, draw the configuration diagram OCP , as shown in Fig. 15.27 to some suitable scale, such that $OC = r = 75 \text{ mm}$; $PC = l = 225 \text{ mm}$; and $\theta = 40^\circ$.

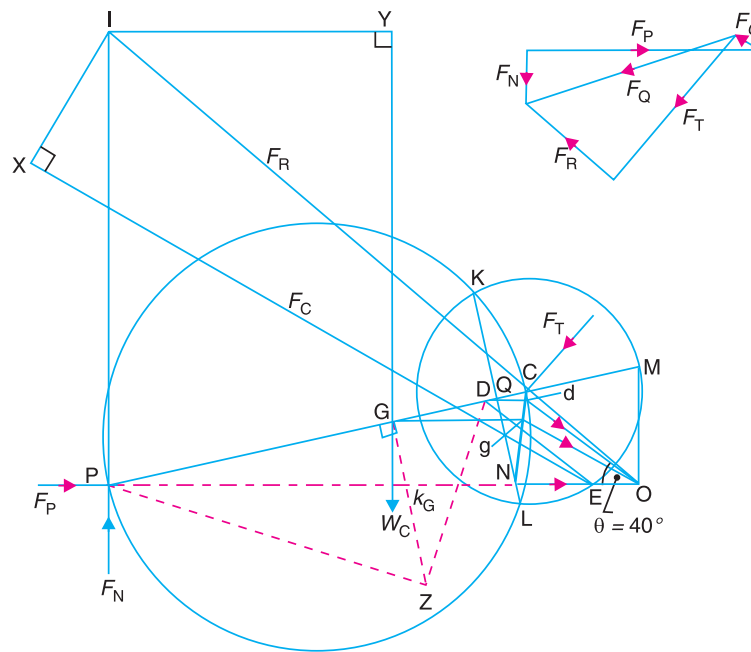

Fig. 15.27

Now, draw the Klien's acceleration diagram $OCQN$. Complete the diagram in the same manner as discussed earlier. By measurement,

$NO = 0.0625 \text{ m}$; $gO = 0.0685 \text{ m}$; $IC = 0.29 \text{ m}$; $IP = 0.24 \text{ m}$; $IY = 0.148 \text{ m}$; and $IX = 0.08 \text{ m}$

We know that force due to gas pressure,

$$F_L = \frac{\pi}{4} \times D^2 \times p = \frac{\pi}{4} \times (0.1125)^2 \times 1.8 \times 10^6 = 17\,895 \text{ N}$$

Inertia force due to mass of the reciprocating parts,

$$F_I = m_R \times \omega^2 \times NO = 2.4 (125.7)^2 \times 0.0625 = 2370 \text{ N}$$

\therefore Net force on the piston,

$$F_P = F_L - F_I = 17\,895 - 2370 = 15\,525 \text{ N}$$

Inertia force due to mass of the connecting rod,

$$F_C = m_C \times \omega^2 \times gO = 1.6 \times (125.7)^2 \times 0.0685 = 1732 \text{ N}$$

Let $F_T =$ Force acting perpendicular to the crank OC .

Now, taking moments about point I ,

$$F_P \times IP = W_C \times IY + F_C \times IX + F_T \times IC$$

$$15\,525 \times 0.24 = 1.6 \times 9.81 \times 0.148 + 1732 \times 0.08 + F_T \times 0.29$$

$$\therefore F_T = 12\,362 \text{ N} \quad \dots (\because W_C = m_C \cdot g)$$

Let us now find the values of F_N and F_R in magnitude and direction. Draw the force polygon as shown in Fig. 15.25.

By measurement, $F_N = 3550$ N; and $F_R = 7550$ N

The magnitude and direction of the resultant force on the crank pin is given by F_Q , which is the resultant of F_R and F_T .

By measurement, $F_Q = 13\,750$ N **Ans.**

EXERCISES

1. The crank and connecting rod of a reciprocating engine are 150 mm and 600 mm respectively. The crank makes an angle of 60° with the inner dead centre and revolves at a uniform speed of 300 r.p.m. Find, by Klein's or Ritterhaus's construction, 1. Velocity and acceleration of the piston, 2. Velocity and acceleration of the mid-point D of the connecting rod, and 3. Angular velocity and angular acceleration of the connecting rod. **[Ans. 4.6 m/s, 61.7 m/s² ; 4.6 m/s, 93.8 m/s² ; 4.17 rad/s, 214 rad/s²]**
2. In a slider crank mechanism, the length of the crank and connecting rod are 100 mm and 400 mm respectively. The crank rotates uniformly at 600 r.p.m. clockwise. When the crank has turned through 45° from the inner dead centre, find, by analytical method : 1. Velocity and acceleration of the slider, 2. Angular velocity and angular acceleration of the connecting rod. Check your result by Klein's or Bennett's construction. **[Ans. 5.2 m/s; 279 m/s²; 11 rad/s; 698 rad/s²]**
3. A petrol engine has a stroke of 120 mm and connecting rod is 3 times the crank length. The crank rotates at 1500 r.p.m. in clockwise direction. Determine: 1. Velocity and acceleration of the piston, and 2. Angular velocity and angular acceleration of the connecting rod, when the piston had travelled one-fourth of its stroke from I.D.C. **[Ans. 8.24 m/s, 1047 m/s²; 37 rad/s, 5816 rad/s²]**
4. The stroke of a steam engine is 600 mm and the length of connecting rod is 1.5 m. The crank rotates at 180 r.p.m. Determine: 1. velocity and acceleration of the piston when crank has travelled through an angle of 40° from inner dead centre, and 2. the position of the crank for zero acceleration of the piston. **[Ans. 4.2 m/s, 85.4 m/s²; 79.3° from I.D.C]**
5. The following data refer to a steam engine :
Diameter of piston = 240 mm; stroke = 600 mm; length of connecting rod = 1.5 m; mass of reciprocating parts = 300 kg; speed = 125 r.p.m.
Determine the magnitude and direction of the inertia force on the crankshaft when the crank has turned through 30° from inner dead centre. **[Ans. 14.92 kN]**
6. A vertical petrol engine 150 mm diameter and 200 mm stroke has a connecting rod 350 mm long. The mass of the piston is 1.6 kg and the engine speed is 1800 r.p.m. On the expansion stroke with crank angle 30° from top dead centre, the gas pressure is 750 kN/m². Determine the net thrust on the piston. **[Ans. 7535 N]**
7. A horizontal steam engine running at 240 r.p.m. has a bore of 300 mm and stroke 600 mm. The connecting rod is 1.05 m long and the mass of reciprocating parts is 60 kg. When the crank is 60° past its inner dead centre, the steam pressure on the cover side of the piston is 1.125 N/mm² while that on the crank side is 0.125 N/mm². Neglecting the area of the piston rod, determine : 1. the force in the piston rod ; and 2. the turning moment on the crankshaft. **[Ans. 66.6 kN ; 19.86 kN-m]**
8. A steam engine 200 mm bore and 300 mm stroke has a connecting rod 625 mm long. The mass of the reciprocating parts is 15 kg and the speed is 250 r.p.m. When the crank is at 30° to the inner dead centre and moving outwards, the difference in steam pressures is 840 kN/m². If the crank pin radius is 30 mm, determine: 1. the force on the crankshaft bearing; and 2. the torque acting on the frame. **[Ans. 20.04 kN ; 2253 N-m]**
9. A vertical single cylinder engine has a cylinder diameter of 250 mm and a stroke of 450 mm. The reciprocating parts have a mass of 180 kg. The connecting rod is 4 times the crank radius and the speed is 360 r.p.m. When the crank has turned through an angle of 45° from top dead centre, the net pressure on the piston is 1.05 MN/m². Calculate the effective turning moment on the crankshaft for this position. **[Ans. 2368 N-m]**

562 • Theory of Machines

10. A horizontal, double acting steam engine has a stroke of 300 mm and runs at 240 r.p.m. The cylinder diameter is 200 mm, connecting rod is 750 mm long and the mass of the reciprocating parts is 70 kg. The steam is admitted at 600 kN/m^2 for one-third of the stroke, after which expansion takes place according to the hyperbolic law $p.V = \text{constant}$. The exhaust pressure is 20 kN/m^2 . Neglecting the effect of clearance and the diameter of the piston rod, find : 1. Thrust in the connecting rod, and 2. Effective turning moment on the crankshaft when the crank has turned through 120° from inner dead centre. **[Ans. 11.506 kN; 1322 N-m]**
11. A horizontal steam engine running at 150 r.p.m. has a bore of 200 mm and a stroke of 400 mm. The connecting rod is 1 m long and the reciprocating parts has a mass of 60 kg. When the crank has turned through an angle of 30° from inner dead centre, steam pressure on the cover side is 0.6 N/mm^2 while on the crankside is 0.1 N/mm^2 . Neglecting the area of the piston rod, determine: 1. turning moment on the crankshaft, 2. acceleration of the flywheel, if the mean resistance torque is 600 N-m and the moment of inertia is 2.8 kg-m^2 . **[Ans. 1508 N-m; 324.3 rad/s²]**
12. The ratio of the connecting rod length to crank length for a vertical petrol engine is 4:1. The bore / stroke is 80/100 mm and mass of the reciprocating parts is 1 kg. The gas pressure on the piston is 0.7 N/mm^2 when it has moved 10 mm from T.D.C. on its power stroke. Determine the net load on the gudgeon pin. The engine runs at 1800 r.p.m. At what engine speed will this load be zero? **[Ans. 1862.8 N; 2616 r.p.m.]**
13. A petrol engine 90 mm in diameter and 120 mm stroke has a connecting rod of 240 mm length. The piston has a mass of 1 kg and the speed is 1800 r.p.m. On the explosion stroke with the crank at 30° from top dead centre, the gas pressure is 0.5 N/mm^2 . Find :
1. the resultant load on the gudgeon pin, 2. the thrust on the cylinder walls, and 3. the speed, above which other things remaining same, the gudgeon pin load would be reserved in direction.
Also calculate the crank effort at the given position of the crank. **[Ans. 1078 N; 136 N ; 2212 r.p.m.; 39.4 N-m]**
14. A single cylinder vertical engine has a bore of 300 mm, stroke 360 mm and a connecting rod of length 720 mm. The mass of the reciprocating parts is 130 kg. When the piston is at quarter stroke from top dead centre and is moving downwards, the net pressure on it is 0.6 MPa. If the speed of the engine is 250 r.p.m., calculate the turning moment on the crankshaft at the instant corresponding to the position stated above. **[Ans. 6295 N-m]**
15. A horizontal, single cylinder, single acting, otto cycle gas engine has a bore of 300 mm and a stroke of 500 mm. The engine runs at 180 r.p.m. The ratio of compression is 5.5. The maximum explosion pressure is 3.2 N/mm^2 gauge and expansion follows the law $p.V^{1.3} = \text{constant}$. If the mass of the piston is 150 kg and the connecting rod is 1.25 m long. Calculate the turning moment on the crankshaft when the crank has turned through 60° from the inner dead centre. The atmospheric pressure is 0.1 N/mm^2 . **[Ans. 15.6 kN-m]**
16. A vertical single cylinder, diesel engine running at 300 r.p.m. has a cylinder diameter 250 mm and stroke 400 mm. The mass of the reciprocating parts is 200 kg. The length of the connecting rod is 0.8 m. The ratio of compression is 14 and the pressure remains constant during injection of oil for 1/10th of stroke. If the index of the law of expansion and compression is 1.35, find the torque on the crankshaft when it makes an angle of 60° with the top dead centre during the expansion stroke. The suction pressure may be taken as 0.1 N/mm^2 . **[Ans. 7034 N-m]**
17. A gas engine is coupled to a compressor, the two cylinders being horizontally opposed with the pistons connected to a common crank pin. The stroke of each piston is 500 mm and the ratio of the length of the connecting rod to the length of crank is 5. The cylinder diameters are 200 mm and 250 mm and the masses of reciprocating parts are 130 kg and 150 kg respectively. When the crank has moved through 60° from inner dead centre on the firing stroke, the pressure of gas on the engine cylinder is 1 N/mm^2 gauge and the pressure in the compressor cylinder is 0.1 N/mm^2 gauge. If the crank moves with 200 r.p.m. and the flywheel of radius of gyration 1 m has a mass of 1350 kg, determine the angular acceleration of the flywheel. **[Ans. 2.4 rad/s²]**
18. The length of a connecting rod of an engine is 500 mm measured between the centres and its mass is 18 kg. The centre of gravity is 125 mm from the crank pin centre and the crank radius is 100 mm.

Determine the dynamically equivalent system keeping one mass at the small end. The frequency of oscillation of the rod, when suspended from the centre of the small end is 43 vibrations per minute.

[Ans. 4.14 kg; 13.86 kg]

19. A small connecting rod 220 mm long between centres has a mass of 2 kg and a moment of inertia of 0.02 kg-m^2 about its centre of gravity. The centre of gravity is located at a distance of 150 mm from the small end centre. Determine the dynamically equivalent two mass system when one mass is located at the small end centre.

If the connecting rod is replaced by two masses located at the two centres, find the correction couple that must be applied for complete dynamical equivalence of the system when the angular acceleration of the connecting rod is $20\,000 \text{ rad/s}^2$ anticlockwise.

[Ans. 0.617 kg; 1.383 kg; 20 N-m (anticlockwise)]

20. The connecting rod of a horizontal reciprocating engine is 400 mm and length of the stroke is 200 mm. The mass of the reciprocating parts is 125 kg and that of the connecting rod is 100 kg. The radius of gyration of the connecting rod about an axis through the centre of gravity is 120 mm and the distance of centre of gravity of the connecting rod from big end centre is 160 mm. The engine runs at 750 r.p.m. Determine the torque exerted on the crankshaft when the crank has turned 30° from the inner dead centre.

[Ans. 7078 N-m]

21. If the crank has turned through 135° from the inner dead centre in the above question, find the torque on the crankshaft.

[Ans. 5235 N-m]

DO YOU KNOW ?

1. Define 'inertia force' and 'inertia torque'.
2. Draw and explain Klien's construction for determining the velocity and acceleration of the piston in a slider crank mechanism.
3. Explain Ritterhaus's and Bennett's constructions for determining the acceleration of the piston of a reciprocating engine.
4. How are velocity and acceleration of the slider of a single slider crank chain determined analytically?
5. Derive an expression for the inertia force due to reciprocating mass in reciprocating engine, neglecting the mass of the connecting rod.
6. What is the difference between piston effort, crank effort and crank-pin effort?
7. Discuss the method of finding the crank effort in a reciprocating single acting, single cylinder petrol engine.
8. The inertia of the connecting rod can be replaced by two masses concentrated at two points and connected rigidly together. How to determine the two masses so that it is dynamically equivalent to the connecting rod? Show this.
9. Given acceleration image of a link. Explain how dynamical equivalent system can be used to determine the direction of inertia force on it.
10. Describe the graphical and analytical method of finding the inertia torque on the crankshaft of a horizontal reciprocating engine.
11. Derive an expression for the correction torque to be applied to a crankshaft if the connecting rod of a reciprocating engine is replaced by two lumped masses at the piston pin and the crank pin respectively.

OBJECTIVE TYPE QUESTIONS

1. When the crank is at the inner dead centre, in a horizontal reciprocating steam engine, then the velocity of the piston will be
- (a) zero (b) minimum (c) maximum

564 • Theory of Machines

2. The acceleration of the piston in a reciprocating steam engine is given by

$$(a) \quad \omega r \left(\sin \theta + \frac{\sin 2\theta}{n} \right) \qquad (b) \quad \omega r \left(\cos \theta + \frac{\cos 2\theta}{n} \right)$$
$$(c) \quad \omega^2 r \left(\sin \theta + \frac{\sin 2\theta}{n} \right) \qquad (d) \quad \omega^2 r \left(\cos \theta + \frac{\cos 2\theta}{n} \right)$$

where ω = Angular velocity of the crank,
 r = Radius of the crank,
 θ = Angle turned by the crank from inner dead centre, and
 n = Ratio of length of connecting rod to crank radius.

3. A rigid body, under the action of external forces, can be replaced by two masses placed at a fixed distance apart. The two masses form an equivalent dynamical system, if

- (a) the sum of two masses is equal to the total mass of the body
(b) the centre of gravity of the two masses coincides with that of the body
(c) the sum of mass moment of inertia of the masses about their centre of gravity is equal to the mass moment of inertia of the body
(d) all of the above

4. The essential condition of placing the two masses, so that the system becomes dynamically equivalent is

$$(a) \quad l_1 \cdot l_2 = k_G^2 \qquad (b) \quad l_1 \cdot l_2 = k_G \qquad (c) \quad l_1 = k_G \qquad (d) \quad l_2 = k_G$$

where l_1 and l_2 = Distance of two masses from the centre of gravity of the body, and
 k_G = Radius of gyration of the body.

5. In an engine, the work done by inertia forces in a cycle is

- (a) positive (b) zero (c) negative (d) none of these

ANSWERS

1. (a) 2. (d) 3. (d) 4. (a) 5. (a)