

# 12 Bending stresses and direct stresses combined

## 12.1 Introduction

Many instances arise in practice where a member undergoes bending combined with a thrust or pull. If a member carries a thrust, direct longitudinal stresses are set up; if a bending moment is now superimposed on the member at some section, additional longitudinal stresses are induced.

In this chapter we shall be concerned with the combined bending and thrust of short stocky members; in such cases the presence of a thrust does not lead to overall instability of the member. Buckling of beams under end thrust is discussed later in Chapter 18.

## 12.2 Combined bending and thrust of a stocky strut

Consider a short column of rectangular cross-section, Figure 12.1(i). The column carries an axial compressive load  $P$ , together with bending moment  $M$ , at some section, applied about the centroidal axis  $Cx$ .

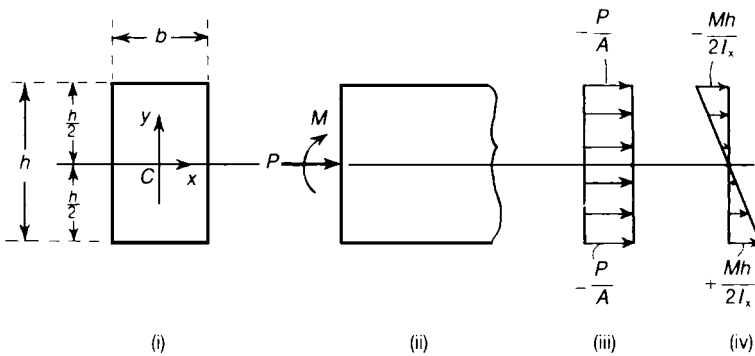

Figure 12.1 Combined bending and thrust of a rectangular cross-section beam.

The area of the column is  $A$ , and  $I_x$  is the second moment of the area about  $Cx$ . If  $P$  acts alone, the average longitudinal stress over the section is

$$-\frac{P}{A}$$

the stress being compressive. If the couple  $M$  acts alone, and if the material remains elastic, the

longitudinal stress in any fibre a distance  $y$  from  $Cx$  is

$$-\frac{My}{I_x}$$

for positive values of  $y$ . We assume now that the combined effect of the thrust and the bending moment is the sum of the separate effects of  $P$  and  $M$ . The stresses due to  $P$  and  $M$  acting separately are shown in Figure 12.1(iii) and (iv). On combining the two stress systems, the resultant stress in any fibre is

$$\sigma = -\frac{P}{A} - \frac{My}{I_x} \tag{12.1}$$

Clearly the greatest compressive stress occurs in the upper extreme fibres, and has the value

$$\sigma_{\max} = -\frac{P}{A} - \frac{Mh}{2I_x} \tag{12.2}$$

In the lower fibres of the beam  $y$  is negative; in the extreme lower fibres

$$\sigma = -\frac{P}{A} + \frac{Mh}{2I_x} \tag{12.3}$$

which is compressive or tensile depending upon whether  $(Mh/2I_x)$  is less than or greater than  $(P/A)$ . The two possible types of stress distribution are shown in Figure 12.2(i) and (ii). When  $(Mh/2I_x) < (P/A)$ , the stresses are compressive for all parts of the cross-section, Figure 12.2(i). When  $(Mh/2I_x) > (P/A)$ , the stress is zero at a distance  $(PI_x/AM)$  below the centre line of the beam, Figure 12.2(ii); this defines the position of the neutral axis of the column, or the axis of zero strain. In Figure 12.2(i) the imaginary neutral axis is also a distance  $(PI_x/AM)$  from the centre line, but it lies outside the cross-section.

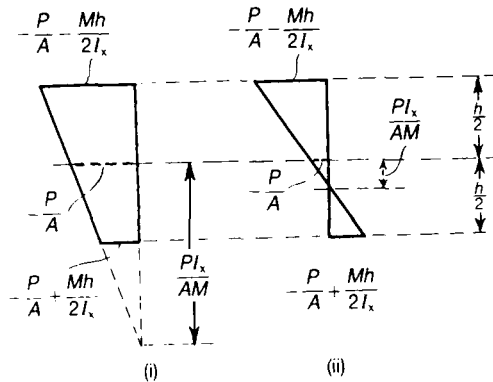
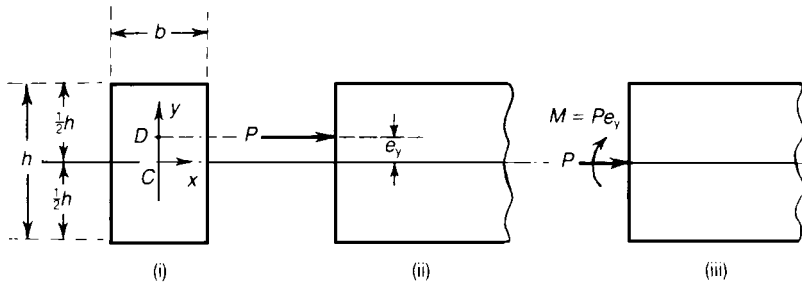

Figure 12.2 Position of the neutral axis for combined bending and thrust.

## 12.3 Eccentric thrust

We can use the analysis of Section 12.2 to find the stresses due to the eccentric thrust. The column of rectangular cross-section shown in Figure 12.3(i) carries a thrust  $P$ , which can be regarded as concentrated at the point  $D$ , which lies on the centroidal axis  $Cy$ , at a distance  $e_y$  from  $C$ , Figure 12.3(ii). The eccentric load  $P$  is statically equivalent to an axial thrust  $P$  and a bending moment  $Pe_y$  applied about  $Cx$ , Figure 12.3(iii). Then, from equation (12.1), the longitudinal stress any fibre is

$$\sigma = -\frac{P}{A} - \frac{Pe_y y}{I_x} = -\frac{P}{A} \left( 1 + \frac{Ae_y y}{I_x} \right) \quad (12.4)$$



**Figure 12.3** Column of rectangular cross-section carrying an eccentric thrust.

We are interested frequently in the condition that no tensile stresses occur in the column; clearly, tensile stresses are most likely to occur in the lowest extreme fibres, where

$$\sigma = -\frac{P}{A} \left( 1 - \frac{Ae_y h}{2I_x} \right) \quad (12.5)$$

This stress is tensile if

$$\frac{Ae_y h}{2I_x} > 1 \quad (12.6)$$

that is, if

$$\frac{6e_y}{h} > 1$$

or

$$e_y = \frac{1}{6}h \quad (12.7)$$

Now suppose the thrust  $P$  is applied eccentrically about both centroidal axes, at a distance  $e_x$  from the axis  $Cy$  and a distance  $e_y$  from the axis  $Cx$ , Figure 12.4. We replace the eccentric thrust  $P$  by an axial thrust  $P$  at  $C$ , together with couples  $Pe_y$  and  $Pe_x$  about  $Cx$  and  $Cy$ , respectively.

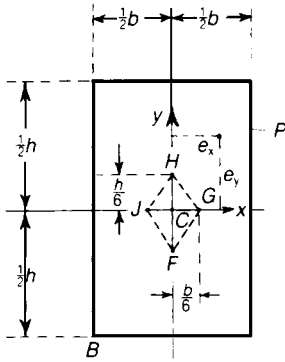

Figure 12.4 Core of a rectangular cross-section.

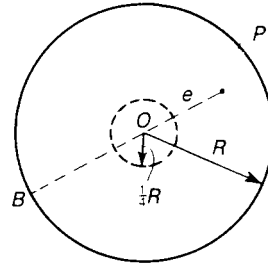

Figure 12.5 Core of a circular cross-section.

The resultant compressive stress at any fibre defined by co-ordinate  $(x, y)$  is

$$\begin{aligned} \sigma &= -\frac{P}{A} - \frac{Pe_x x}{I_y} - \frac{Pe_y y}{I_x} \\ &= -\frac{P}{A} \left[ 1 + \frac{Ae_x x}{I_y} + \frac{Ae_y y}{I_x} \right] \end{aligned} \tag{12.8}$$

Suppose  $e_x$  and  $e_y$  are both positive; then a tensile stress is more likely to occur at the corner  $B$  of the rectangle. The stress at  $B$  is tensile when

$$1 - \frac{Ae_x b}{2I_y} - \frac{Ae_y h}{2I_x} < 0 \tag{12.9}$$

On substituting for  $A$ ,  $I_x$  and  $I_y$ , this becomes

$$1 - \frac{6e_x}{h} - \frac{6e_y}{h} < 0 \tag{12.10}$$

If  $P$  is applied at a point on the side of the line  $HG$  remote from  $C$ , this inequality is satisfied, and the stress at  $B$  becomes tensile, regardless of the value of  $P$ . Similarly, the lines  $HJ$ ,  $JF$  and  $FG$  define limits on the point of application of  $P$  for the development of tensile stresses at the other

three corners of the column. Clearly, if no tensile stresses are to be induced at all, the load  $P$  must not be applied outside the parallelogram  $FGHJ$  in Figure 12.4; the region  $FGHJ$  is known as the *core of the section*. For the rectangular section of Figure 12.4 the core is a parallelogram with diagonals of lengths  $\frac{1}{3}h$  and  $\frac{1}{3}b$ .

For a column with a circular cross-section of radius  $R$ , Figure 12.5, the tensile stress is most likely to develop at a point  $B$  on the perimeter diametrically opposed to the point of application of  $P$ . The stress at  $B$  is

$$\sigma = -\frac{P}{A} + \frac{PeR}{I} = -\frac{P}{A} \left( 1 - \frac{AeR}{I} \right) \quad (12.11)$$

where  $I$  is the second moment of area about a diameter. Tensile stresses are developed if

$$\frac{AeR}{I} > 1 \quad (12.12)$$

On substituting for  $A$  and  $I$ , this becomes

$$\frac{4e}{R} > 1$$

or

$$e > \frac{R}{4} \quad (12.13)$$

The core of the section is then a circle of radius  $\frac{1}{4}R$ .

**Problem 12.1** Find the maximum stress on the section  $AB$  of the clamp when a pressure of 2500 N is exerted by the screw. The section is rectangular 2.5 cm by 1 cm. (Cambridge)

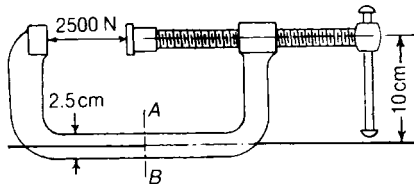

### Solution

The section  $AB$  is subjected to a tension of 2500 N, and a bending moment  $(2500)(0.10) = 250$  Nm. The area of the section  $= 0.25 \times 10^{-3} \text{ m}^2$ . The direct tensile stress  $= (2500)/(0.25 \times 10^{-3}) = 10 \text{ MN/m}^2$ . The second moment of area  $= 1/12 (0.01)(0.025)^3 = 13.02 \times 10^{-9} \text{ m}^4$ .

Therefore, the maximum bending stresses due to the couple of 250 Nm are equal to

$$\frac{(250)(0.0125)}{(13.02 \times 10^{-9})} = 240 \text{ MN/m}^2$$

Hence the maximum tensile stress on the section is

$$(240 + 10) = 250 \text{ MN/m}^2$$

The maximum compressive stress is

$$(240 - 10) = 230 \text{ MN/m}^2$$

**Problem 12.2** A masonry pier has a cross-section 3 m by 2 m, and is subjected to a load of 1000 kN, the line of the resultant being 1.80 m from one of the shorter sides, and 0.85 m from one of the longer sides. Find the maximum tensile and compressive stresses produced. (Cambridge)

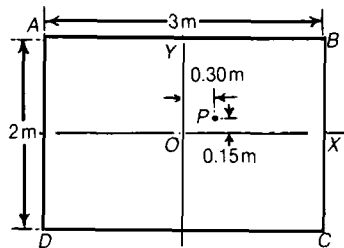

Solution

$P$  represents the line of action of the thrust. The bending moments are

$$(0.15)(1000 \times 10^3) = 150 \text{ kNm about } OX$$

$$(0.30)(1000 \times 10^3) = 300 \text{ kNm about } OY$$

Now,

$$I_x = \frac{1}{12} (3)(2)^3 = 2 \text{ m}^4$$

$$I_y = \frac{1}{12} (2)(3)^3 = 4.5 \text{ m}^4$$

The cross-sectional area is

$$A = (3)(2) = 6 \text{ m}^2$$

For a point whose co-ordinates are  $(x, y)$  the compressive stress is

$$\sigma = -\frac{P}{A} \left( 1 + \frac{Ae_x x}{I_y} + \frac{Ae_y y}{I_x} \right)$$

which gives

$$\sigma = -\frac{1000 \times 10^3}{6} \left( 1 + \frac{x}{2.5} + \frac{9y}{20} \right)$$

The compressive stress is a maximum at  $B$ , where  $x = 1.5$  m and  $y = 1$  m. Then

$$\sigma_B = -\frac{10^6}{6} \left( 1 + \frac{3}{5} + \frac{9}{20} \right) = -0.342 \text{ MN/m}^2$$

The stress at  $D$ , where  $x = -1.5$  m and  $y = -1$  m, is

$$\sigma_D = -\frac{10^6}{6} \left( 1 - \frac{3}{5} - \frac{9}{20} \right) = +0.008 \text{ MN/m}^2$$

which is the maximum tensile stress.

## 12.4 Pre-stressed concrete beams

The simple analysis of Section 12.2 is useful for problems of pre-stressed concrete beams. A concrete beam, unreinforced with steel, can withstand negligible bending loads because concrete is so weak in tension. But if the beam be pre-compressed in some way, the tensile stresses induced by bending actions are countered by the compressive stresses already present. In Figure 12.6, for example, a line of blocks carries an axial thrust; if this is sufficiently large, the line of blocks can be used in the same way as a solid beam.

Figure 12.6 Bending strength of a pre-compressed line of blocks.

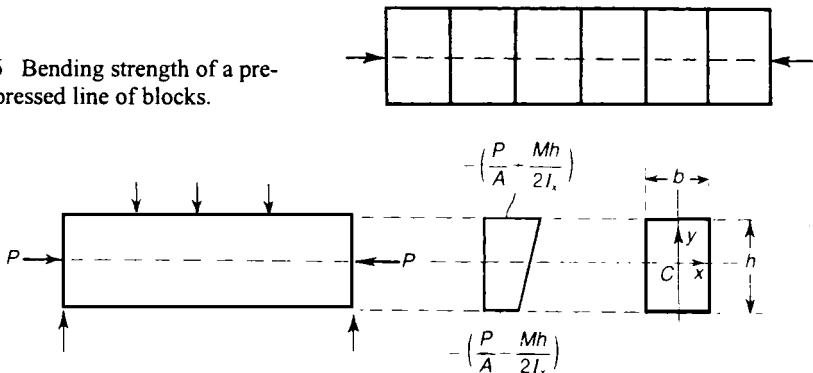

Figure 12.7 Concrete beam with axial pre-compression.

Suppose a concrete beam of rectangular cross-section, Figure 12.7, carries some system of lateral loads and is supported at its ends. An axial pre-compression  $P$  is applied at the ends. If  $M$  is the sagging moment at any cross-section, the greatest compressive stress occurs in the extreme top fibres, and has the value

$$\sigma = -\left(\frac{P}{A} + \frac{Mh}{2I_x}\right) \quad (12.14)$$

The stress in the extreme bottom fibres is

$$\sigma = -\left(\frac{P}{A} - \frac{Mh}{2I_x}\right) \quad (12.15)$$

Now suppose the maximum compressive stress in the concrete is limited to  $\sigma_1$ , and the maximum tensile stress to  $\sigma_2$ . Then we must have

$$\frac{P}{A} + \frac{Mh}{2I_x} \leq \sigma_1 \quad (12.16)$$

and

$$-\frac{P}{A} + \frac{Mh}{2I_x} \leq \sigma_2 \quad (12.17)$$

Then the design conditions are

$$\frac{Mh}{2I_x} \leq \sigma_1 - \frac{P}{A} \quad (12.18)$$

$$\frac{Mh}{2I_x} \leq \sigma_2 + \frac{P}{A} \quad (12.19)$$

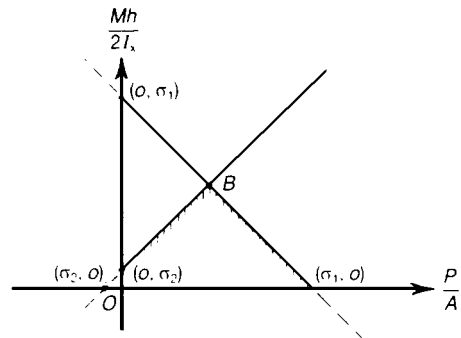

**Figure 12.8** Optimum conditions for a beam with axial pre-compression.



These two inequalities are shown graphically in Figure 12.8, in which  $(P/A)$  is plotted against  $(Mh/2I_x)$ . Usually  $\sigma_2$  is of the order of one-tenth of  $\sigma_1$ . The optimum conditions satisfying both inequalities occur at the point B; the maximum bending moment which can be given by

$$\frac{Mh}{I_x} = (\sigma_1 + \sigma_2) \tag{12.20}$$

that is,

$$M_{\max} = \frac{I_x}{h} (\sigma_1 + \sigma_2) \tag{12.21}$$

The required axial thrust for this load is

$$P = \frac{1}{2}A (\sigma_1 - \sigma_2) \tag{12.22}$$

Some advantage is gained by pre-compressing the beam eccentrically; in Figure 12.9(i) a beam of rectangular cross-section carries a thrust  $P$  at a depth  $(1/6)h$  below the centre line. As we saw in Section 12.3, this lies on the edge of the core of cross-section, and no tensile stresses are induced. In the upper extreme fibres the longitudinal stress is zero, and in the lower extreme fibres the compressive stress is  $2P/A$ , Figure 12.9(i).

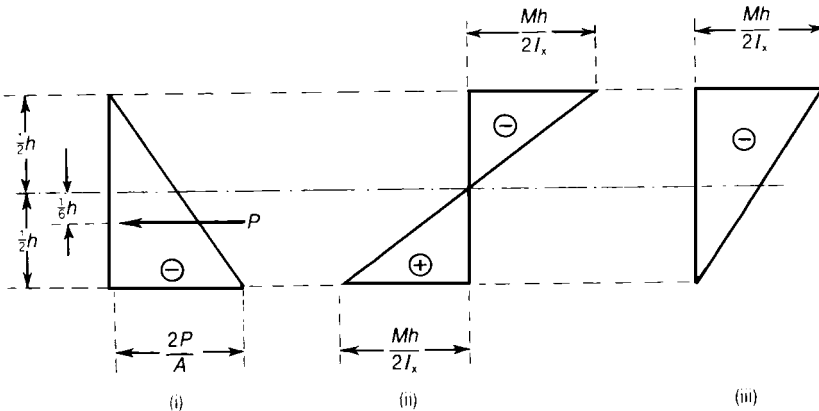

Figure 12.9 Concrete beam with eccentric pre-compression.

Now suppose a sagging bending moment  $M$  is superimposed on the beam; the extreme fibre stresses due to  $M$  are  $(Mh/2I_x)$  tensile on the lower and compressive on the upper fibres, Figure 12.9(ii). If

$$\frac{2P}{A} = \frac{Mh}{2I_x} \tag{12.23}$$

then the resultant stresses, Figure 12.9(iii), are zero in the extreme lower fibres and a compressive stress of  $(Mh/2I_x)$  in the extreme upper fibres. If this latter compressive stress does not exceed  $\sigma_1$ , the allowable stress in concrete, the design is safe. The maximum allowable value of  $M$  is

$$M = \frac{2I_x}{h} \sigma_1 \quad (12.24)$$

As  $\sigma_2$  in equation (12.21) is considerably less than  $\sigma_1$ , the bending moment given by equation (12.21) is approximately half that given by equation (12.24). Thus pre-compression by an eccentric load gives a considerably higher bending strength.

In practice the thrust is applied to the beam either externally through rigid supports, or by means of a stretched high-tensile steel wire passing through the beam and anchored at each end.

### Further problems (answers on page 693)

- 12.3** The single rope of a cantilever crane supports a load of 200 kN and passes over two pulleys and then vertically down the axis of the crane to the hoisting apparatus. The section  $AB$  of the crane is a hollow rectangle. The outside dimensions are 37.5 cm and 75 cm and the material is 2.5 cm thick all round, and the longer dimension is in the direction  $AB$ . Calculate the maximum tensile and compressive stresses set up in the section, and locate the position of the neutral axis. (Cambridge)

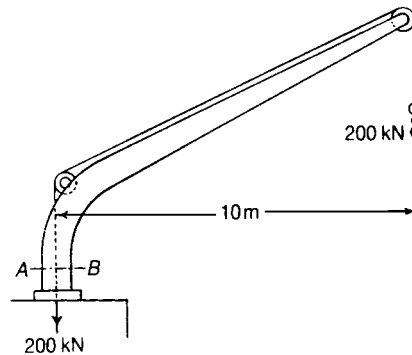

- 12.4** The horizontal cross-section of the cast-iron standard of a vertical drilling machine has the form shown. The line of thrust of the drill passes through  $P$ . Find the greatest value the thrust may have without the tensile stress exceeding  $15 \text{ MN/m}^2$ . What will be the stress along the face  $AB$ ? (Cambridge)

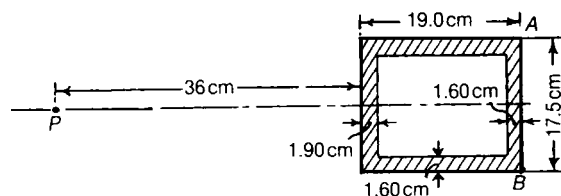

- 12.5** A vertical masonry chimney has an internal diameter  $d_i$  and an external diameter  $d_o$ . The base of the chimney is given a horizontal acceleration  $a \text{ m/s}^2$ , and the whole chimney moves horizontally with this acceleration. Show that at a section at depth  $h$  below the top of the chimney, the resultant normal force acts at a distance  $ah/2g$  from the centre of the section. If the chimney behaves as an elastic solid, show that at a depth  $g(d_o^2 + d_i^2)/4ad_o$  below the top, tensile stress will be developed in the material. (Cambridge)
- 12.6** A link of a valve gear has to be curved in one plane, for the sake of clearance. Estimate the maximum tensile and compressive stress in the link if the thrust is 2500 N. (Cambridge)

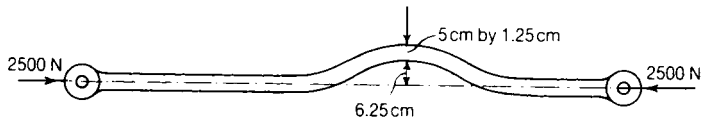

- 12.7** A cast-iron crank has a section on the line  $AB$  of the form shown. Show how to determine the greatest compressive and tensile stresses at  $AB$ , normal to the section, due to the thrust  $P$  of the connecting rod at the angle  $\phi$  shown.

If the stresses at the section must not exceed  $75 \text{ MN/m}^2$ , either in tension or compression, find the maximum value of the thrust  $P$ . (Cambridge)

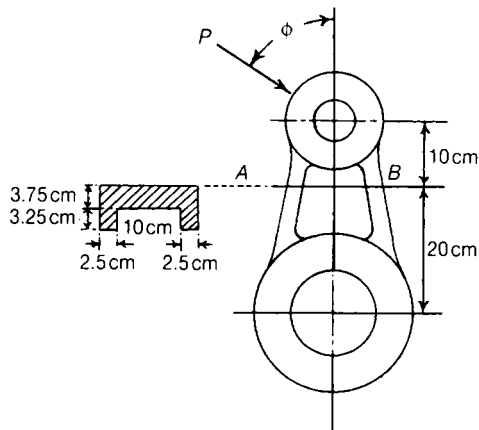

- 12.8** The load on the bearing of a cast-iron bracket is 5 kN. The form of the section  $AB$  is given. Calculate the greatest tensile stress across the section  $AB$  and the distance of the neutral axis of the section from the centre of gravity of the section. (*Cambridge*)

