

Introduction to

STATICS
and
DYNAMICS

Problem Book

Rudra Pratap and Andy Ruina

Spring 2001

© Rudra Pratap and Andy Ruina, 1994-2001. All rights reserved. No part of this book may be reproduced, stored in a retrieval system, or transmitted, in any form or by any means, electronic, mechanical, photocopying, or otherwise, without prior written permission of the authors.

This book is a pre-release version of a book in progress for Oxford University Press.

The following are amongst those who have helped with this book as editors, artists, advisors, or critics: Alexa Barnes, Joseph Burns, Jason Cortell, Ivan Dobrianov, Gabor Domokos, Thu Dong, Gail Fish, John Gibson, Saptarsi Haldar, Dave Heimstra, Theresa Howley, Herbert Hui, Michael Marder, Elaina McCartney, Arthur Ogawa, Kalpana Pratap, Richard Rand, Dane Quinn, Phoebus Rosakis, Les Schaeffer, David Shipman, Jill Startzell, Saskya van Nouhuys, Bill Zobrist. Mike Coleman worked extensively on the text, wrote many of the examples and homework problems and created many of the figures. David Ho has brought almost all of the artwork to its present state. Some of the homework problems are modifications from the Cornell's Theoretical and Applied Mechanics archives and thus are due to T&AM faculty or their libraries in ways that we do not know how to give proper attribution. Many unlisted friends, colleagues, relatives, students, and anonymous reviewers have also made helpful suggestions.

Software used to prepare this book includes TeXtures, *BLUESKY's* implementation of *LaTeX*, *Adobe Illustrator* and *MATLAB*.

Most recent text modifications on January 21, 2001.

Contents

Problems for Chapter 1	0
Problems for Chapter 2	2
Problems for Chapter 3	10
Problems for Chapter 4	15
Problems for Chapter 5	18
Problems for Chapter 6	31
Problems for Chapter 7	41
Problems for Chapter 8	60
Problems for Chapter 9	74
Problems for Chapter 10	83
Problems for Chapter 11	88
Problems for Chapter 12	100
Answers to *'d questions	

Problems for Chapter 1

Introduction to mechanics Because no mathematical skills have been taught so far, the questions below just demonstrate the ideas and vocabulary you should have gained from the reading.

1.1 What is mechanics?

1.2 Briefly define each of the words below (using rough English, not precise mathematical language):

- a) Statics,
- b) Dynamics,
- c) Kinematics,
- d) Strength of materials,
- e) Force,
- f) Motion,
- g) Linear momentum,
- h) Angular momentum,
- i) A rigid body.

1.3 This chapter says there are three “pillars” of mechanics of which the third is ‘Newton’s’ laws, what are the other two?

1.4 This book organizes the laws of mechanics into 4 basic laws numbered 0-III, not the standard ‘Newton’s three laws’. What are these four laws (in English, no equations needed)?

1.5 Describe, as precisely as possible, a problem that is not mentioned in the book but which is a mechanics problem. State which quantities are given and what is to be determined by the mechanics solution.

1.6 Describe an engineering problem which is *not* a mechanics problem.

1.7 About how old are Newton’s laws?

1.8 Relativity and quantum mechanics have overthrown Newton’s laws. Why are engineers still using them?

1.9 Computation is part of modern engineering.

- a) What are the three primary computer skills you will need for doing problems in this book?
- b) Give examples of each (different than the examples given).
- c) (optional) Do an example of each on a computer.

Problems for Chapter 2

Vector skills for mechanics

2.1 Vector notation and vector addition

2.1 Represent the vector $\vec{r} = 5\text{ m}\hat{i} - 2\text{ m}\hat{j}$ in three different ways.

2.2 Which one of the following representations of the same vector \vec{F} is wrong and why?

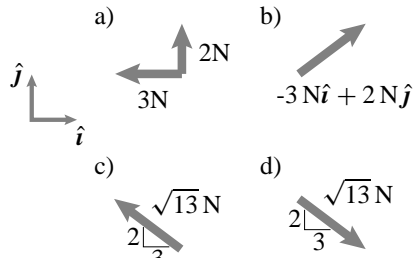

problem 2.2:

(Filename:pfigure2.vec1.2)

2.3 There are exactly two representations that describe the same vector in the following pictures. Match the correct pictures into pairs.

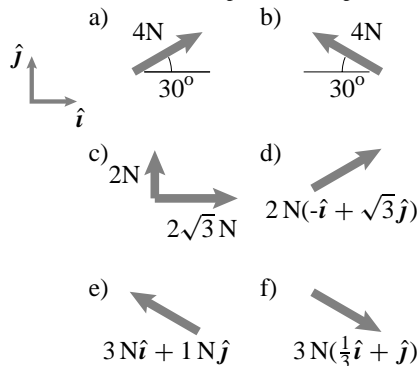

problem 2.3:

(Filename:pfigure2.vec1.3)

2.4 Find the sum of forces $\vec{F}_1 = 20\text{ N}\hat{i} - 2\text{ N}\hat{j}$, $\vec{F}_2 = 30\text{ N}(\frac{1}{\sqrt{2}}\hat{i} + \frac{1}{\sqrt{2}}\hat{j})$, and $\vec{F}_3 = -20\text{ N}(-\hat{i} + \sqrt{3}\hat{j})$.

2.5 In the figure shown below, the position vectors are $\vec{r}_{AB} = 3\text{ ft}\hat{k}$, $\vec{r}_{BC} = 2\text{ ft}\hat{j}$, and $\vec{r}_{CD} = 2\text{ ft}(\hat{j} + \hat{k})$. Find the position vector \vec{r}_{AD} .

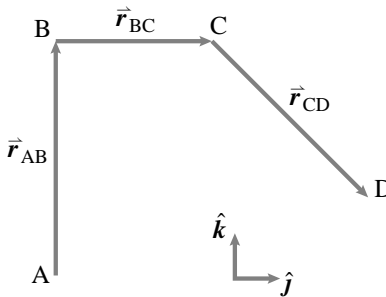

problem 2.5:

(Filename:pfigure2.vec1.5)

2.6 The forces acting on a block of mass $m = 5\text{ kg}$ are shown in the figure, where $F_1 = 20\text{ N}$, $F_2 = 50\text{ N}$, and $W = mg$. Find the sum $\vec{F} (= \vec{F}_1 + \vec{F}_2 + \vec{W})$?

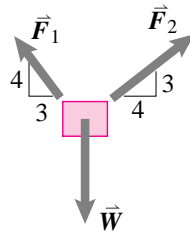

problem 2.6:

(Filename:pfigure2.vec1.6)

2.7 Three position vectors are shown in the figure below. Given that $\vec{r}_{B/A} = 3\text{ m}(\frac{1}{2}\hat{i} + \frac{\sqrt{3}}{2}\hat{j})$ and $\vec{r}_{C/B} = 1\text{ m}\hat{i} - 2\text{ m}\hat{j}$, find $\vec{r}_{A/C}$.

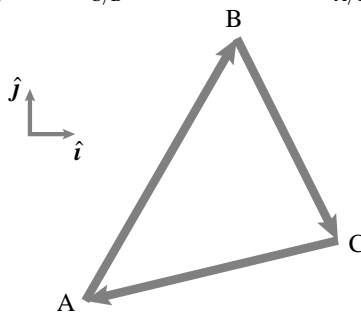

problem 2.7:

(Filename:pfigure2.vec1.7)

2.8 Given that the sum of four vectors \vec{F}_i , $i = 1$ to 4, is zero, where $\vec{F}_1 = 20\text{ N}\hat{i}$, $\vec{F}_2 = -50\text{ N}\hat{j}$, $\vec{F}_3 = 10\text{ N}(-\hat{i} + \hat{j})$, find \vec{F}_4 .

2.9 Three forces $\vec{F} = 2\text{ N}\hat{i} - 5\text{ N}\hat{j}$, $\vec{R} = 10\text{ N}(\cos\theta\hat{i} + \sin\theta\hat{j})$ and $\vec{W} = -20\text{ N}\hat{j}$, sum up to zero. Determine the angle θ and draw the force vector \vec{R} clearly showing its direction.

2.10 Given that $\vec{R}_1 = 1\text{ N}\hat{i} + 1.5\text{ N}\hat{j}$ and $\vec{R}_2 = 3.2\text{ N}\hat{i} - 0.4\text{ N}\hat{j}$, find $2\vec{R}_1 + 5\vec{R}_2$.

2.11 For the unit vectors $\hat{\lambda}_1$ and $\hat{\lambda}_2$ shown below, find the scalars α and β such that $\alpha\hat{\lambda}_2 - 3\hat{\lambda}_1 = \beta\hat{j}$.

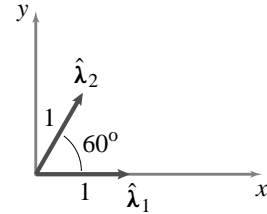

problem 2.11:

(Filename:pfigure2.vec1.11)

2.12 In the figure shown, $T_1 = 20\sqrt{2}\text{ N}$, $T_2 = 40\text{ N}$, and W is such that the sum of the three forces equals zero. If W is doubled, find α and β such that $\alpha\vec{T}_1$, $\beta\vec{T}_2$, and $2\vec{W}$ still sum up to zero.

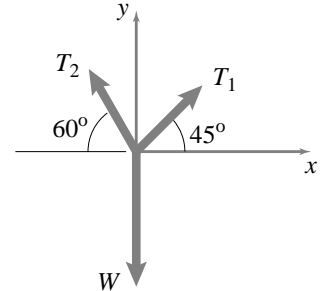

problem 2.12:

(Filename:pfigure2.vec1.12)

2.13 In the figure shown, rods AB and BC are each 4 cm long and lie along y and x axes, respectively. Rod CD is in the xz plane and makes an angle $\theta = 30^\circ$ with the x-axis.

(a) Find \vec{r}_{AD} in terms of the variable length ℓ .

(b) Find ℓ and α such that

$$\vec{r}_{AD} = \vec{r}_{AB} - \vec{r}_{BC} + \alpha\hat{k}.$$

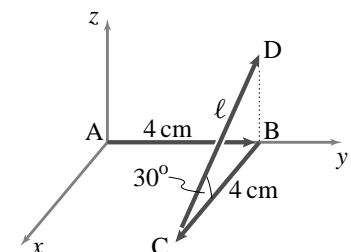

problem 2.13:

(Filename:pfigure2.vec1.13)

2.14 Find the magnitudes of the forces $\vec{F}_1 = 30\text{ N}\hat{i} - 40\text{ N}\hat{j}$ and $\vec{F}_2 = 30\text{ N}\hat{i} + 40\text{ N}\hat{j}$. Draw the two forces, representing them with their magnitudes.

2.15 Two forces $\vec{R} = 2\text{N}(0.16\hat{i} + 0.80\hat{j})$ and $\vec{W} = -36\text{N}\hat{j}$ act on a particle. Find the magnitude of the net force. What is the direction of this force?

2.16 In Problem 2.13, find ℓ such that the length of the position vector \vec{r}_{AD} is 6 cm.

2.17 In the figure shown, $F_1 = 100\text{N}$ and $F_2 = 300\text{N}$. Find the magnitude and direction of $\vec{F}_2 - \vec{F}_1$.

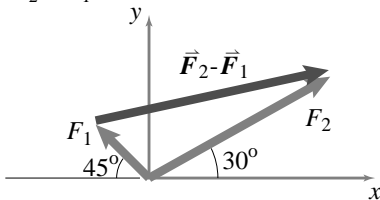

problem 2.17:

(Filename: pfigure2.vec.1.17)

2.18 Let two forces \vec{P} and \vec{Q} act in the direction shown in the figure. You are allowed to change the direction of the forces by changing the angles α and θ while keeping the magnitudes fixed. What should be the values of α and θ if the magnitude of $\vec{P} + \vec{Q}$ has to be the maximum?

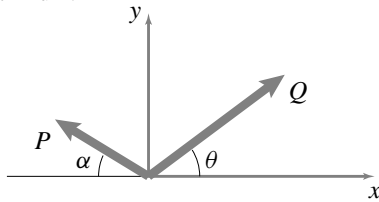

problem 2.18:

(Filename: pfigure2.vec.1.18)

2.19 Two points A and B are located in the xy plane. The coordinates of A and B are (4 mm, 8 mm) and (90 mm, 6 mm), respectively.

- Draw position vectors \vec{r}_A and \vec{r}_B .
- Find the magnitude of \vec{r}_A and \vec{r}_B .
- How far is A from B?

2.20 In the figure shown, a ball is suspended with a 0.8 m long cord from a 2 m long hoist OA.

- Find the position vector \vec{r}_B of the ball.
- Find the distance of the ball from the origin.

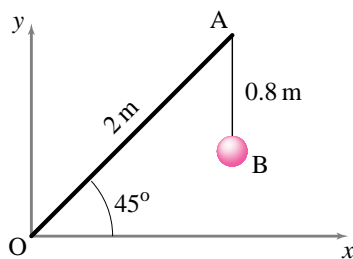

problem 2.20:

(Filename: pfigure2.vec.1.20)

2.21 A 1 m \times 1 m square board is supported by two strings AE and BF. The tension in the string BF is 20 N. Express this tension as a vector.

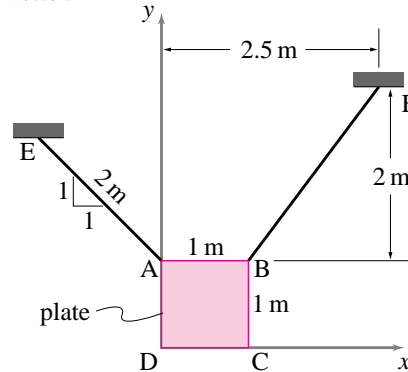

problem 2.21:

(Filename: pfigure2.vec.1.21)

2.22 The top of an L-shaped bar, shown in the figure, is to be tied by strings AD and BD to the points A and B in the yz plane. Find the length of the strings AD and BD using vectors \vec{r}_{AD} and \vec{r}_{BD} .

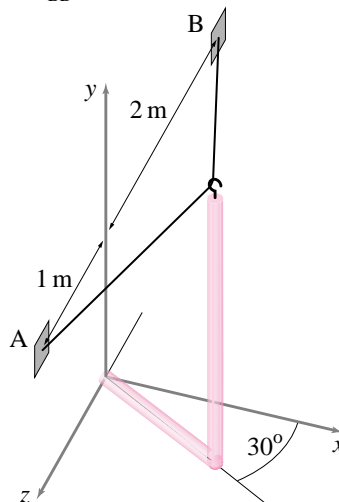

problem 2.22:

(Filename: pfigure2.vec.1.22)

2.23 A cube of side 6 in is shown in the figure.

- Find the position vector of point F, \vec{r}_F , from the vector sum $\vec{r}_F = \vec{r}_D + \vec{r}_{C/D} + \vec{r}_{F/C}$.
- Calculate $|\vec{r}_F|$.
- Find \vec{r}_G using \vec{r}_F .

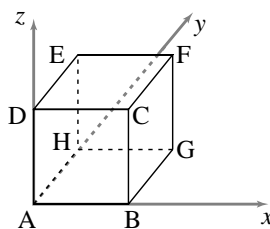

problem 2.23:

(Filename: pfigure2.vec.1.23)

2.24 A circular disk of radius 6 in is mounted on axle $x-x$ at the end of an L-shaped bar as shown in the figure. The disk is tipped 45 degrees with the horizontal bar AC. Two points, P and Q, are marked on the rim of the plate; P directly parallel to the center C into the page, and Q at the highest point above the center C. Taking the base vectors \hat{i} , \hat{j} , and \hat{k} as shown in the figure, find

- the relative position vector $\vec{r}_{Q/P}$,
- the magnitude $|\vec{r}_{Q/P}|$.

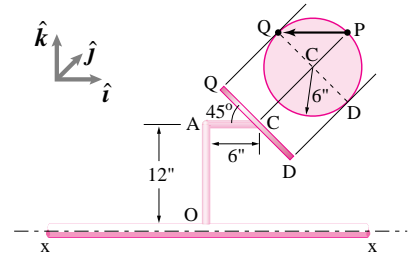

problem 2.24:

(Filename: pfigure2.vec.1.24)

2.25 Find the unit vector $\hat{\lambda}_{AB}$, directed from point A to point B shown in the figure.

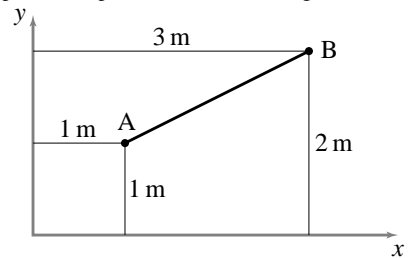

problem 2.25:

(Filename: pfigure2.vec.1.25)

2.26 Find a unit vector along string BA and express the position vector of A with respect to B, $\vec{r}_{A/B}$, in terms of the unit vector.

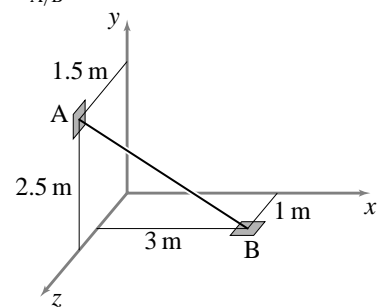

problem 2.26:

(Filename: pfigure2.vec.1.26)

2.27 In the structure shown in the figure, $\ell = 2\text{ft}$, $h = 1.5\text{ft}$. The force in the spring is $\vec{F} = k\vec{r}_{AB}$, where $k = 100\text{ lbf/ft}$. Find a unit vector $\hat{\lambda}_{AB}$ along AB and calculate the spring force $\vec{F} = F\hat{\lambda}_{AB}$.

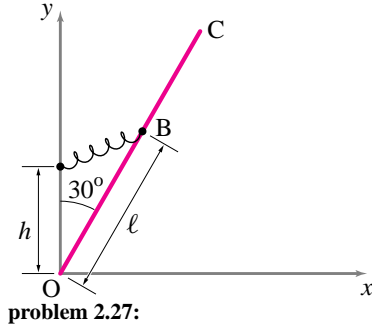

problem 2.27:

(Filename: pfigure2.vec.1.27)

2.28 Express the vector $\vec{r}_A = 2\text{ m}\hat{i} - 3\text{ m}\hat{j} + 5\text{ m}\hat{k}$ in terms of its magnitude and a unit vector indicating its direction.

2.29 Let $\vec{F} = 10\text{ lbf}\hat{i} + 30\text{ lbf}\hat{j}$ and $\vec{W} = -20\text{ lbf}\hat{j}$. Find a unit vector in the direction of the net force $\vec{F} + \vec{W}$, and express the net force in terms of the unit vector.

2.30 Let $\hat{\lambda}_1 = 0.80\hat{i} + 0.60\hat{j}$ and $\hat{\lambda}_2 = 0.5\hat{i} + 0.866\hat{j}$.

- Show that $\hat{\lambda}_1$ and $\hat{\lambda}_2$ are unit vectors.
- Is the sum of these two unit vectors also a unit vector? If not, then find a unit vector along the sum of $\hat{\lambda}_1$ and $\hat{\lambda}_2$.

2.31 If a mass slides from point A towards point B along a straight path and the coordinates of points A and B are (0 in, 5 in, 0 in) and (10 in, 0 in, 10 in), respectively, find the unit vector $\hat{\lambda}_{AB}$ directed from A to B along the path.

2.32 Write the vectors $\vec{F}_1 = 30\text{ N}\hat{i} + 40\text{ N}\hat{j} - 10\text{ N}\hat{k}$, $\vec{F}_2 = -20\text{ N}\hat{j} + 2\text{ N}\hat{k}$, and $\vec{F}_3 = -10\text{ N}\hat{i} - 100\text{ N}\hat{k}$ as a list of numbers (rows or columns). Find the sum of the forces using a computer.

2.2 The dot product of two vectors

2.33 Express the unit vectors \hat{n} and $\hat{\lambda}$ in terms of \hat{i} and \hat{j} shown in the figure. What are the x and y components of $\vec{r} = 3.0\text{ ft}\hat{n} - 1.5\text{ ft}\hat{\lambda}$? *

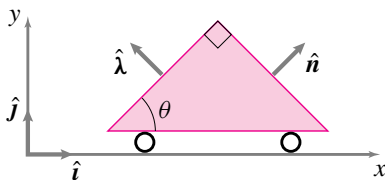

problem 2.33:

(Filename: efig1.2.27)

2.34 Find the dot product of two vectors $\vec{F} = 10\text{ lbf}\hat{i} - 20\text{ lbf}\hat{j}$ and $\hat{\lambda} = 0.8\hat{i} + 0.6\hat{j}$. Sketch \vec{F} and $\hat{\lambda}$ and show what their dot product represents.

2.35 The position vector of a point A is $\vec{r}_A = 30\text{ cm}\hat{i}$. Find the dot product of \vec{r}_A with $\hat{\lambda} = \frac{\sqrt{3}}{2}\hat{i} + \frac{1}{2}\hat{j}$.

2.36 From the figure below, find the component of force \vec{F} in the direction of $\hat{\lambda}$.

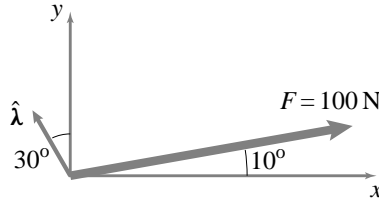

problem 2.36:

(Filename: pfigure2.vec.1.33)

2.37 Find the angle between $\vec{F}_1 = 2\text{ N}\hat{i} + 5\text{ N}\hat{j}$ and $\vec{F}_2 = -2\text{ N}\hat{i} + 6\text{ N}\hat{j}$.

2.38 A force \vec{F} is directed from point A(3,2,0) to point B(0,2,4). If the x-component of the force is 120 N, find the y- and z-components of \vec{F} .

2.39 A force acting on a bead of mass m is given as $\vec{F} = -20\text{ lbf}\hat{i} + 22\text{ lbf}\hat{j} + 12\text{ lbf}\hat{k}$. What is the angle between the force and the z-axis?

2.40 Given $\vec{\omega} = 2\text{ rad/s}\hat{i} + 3\text{ rad/s}\hat{j}$, $\vec{H}_1 = (20\hat{i} + 30\hat{j})\text{ kg m}^2/\text{s}$ and $\vec{H}_2 = (10\hat{i} + 15\hat{j} + 6\hat{k})\text{ kg m}^2/\text{s}$, find (a) the angle between $\vec{\omega}$ and \vec{H}_1 and (b) the angle between $\vec{\omega}$ and \vec{H}_2 .

2.41 The unit normal to a surface is given as $\hat{n} = 0.74\hat{i} + 0.67\hat{j}$. If the weight of a block on this surface acts in the $-\hat{j}$ direction, find the angle that a 1000 N normal force makes with the direction of weight of the block.

2.42 **Vector algebra.** For each equation below state whether:

- The equation is nonsense. If so, why?
- Is always true. Why? Give an example.
- Is never true. Why? Give an example.
- Is sometimes true. Give examples both ways.

You may use trivial examples.

- $\vec{A} + \vec{B} = \vec{B} + \vec{A}$
- $\vec{A} + b = b + \vec{A}$
- $\vec{A} \cdot \vec{B} = \vec{B} \cdot \vec{A}$
- $\vec{B}/\vec{C} = B/C$
- $b/\vec{A} = b/A$
- $\vec{A} = (\vec{A} \cdot \vec{B})\vec{B} + (\vec{A} \cdot \vec{C})\vec{C} + (\vec{A} \cdot \vec{D})\vec{D}$

2.43 Use the dot product to show ‘the law of cosines’; i. e.,

$$c^2 = a^2 + b^2 + 2ab \cos \theta.$$

(Hint: $\vec{c} = \vec{a} + \vec{b}$; also, $\vec{c} \cdot \vec{c} = c \cdot c$)

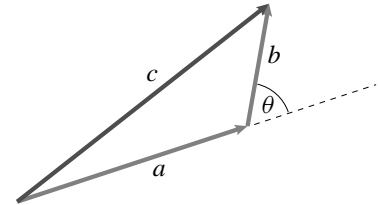

problem 2.43:

(Filename: pfigure.blue.2.1)

2.44 (a) Draw the vector $\vec{r} = 3.5\text{ in}\hat{i} + 3.5\text{ in}\hat{j} - 4.95\text{ in}\hat{k}$. (b) Find the angle this vector makes with the z-axis. (c) Find the angle this vector makes with the x-y plane.

2.45 In the figure shown, $\hat{\lambda}$ and \hat{n} are unit vectors parallel and perpendicular to the surface AB, respectively. A force $\vec{W} = -50\text{ N}\hat{j}$ acts on the block. Find the components of \vec{W} along $\hat{\lambda}$ and \hat{n} .

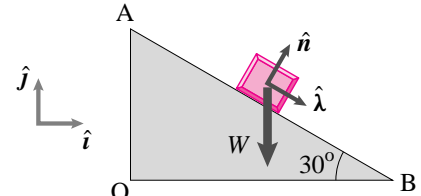

problem 2.45:

(Filename: pfigure2.vec.1.41)

2.46 From the figure shown, find the components of vector \vec{r}_{AB} (you have to first find this position vector) along

- the y-axis, and
- along $\hat{\lambda}$.

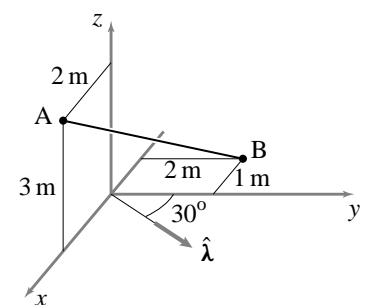

problem 2.46:

(Filename: pfigure2.vec.1.42)

2.47 The net force acting on a particle is $\vec{F} = 2\text{ N}\hat{i} + 10\text{ N}\hat{j}$. Find the components of this force in another coordinate system with basis vectors $\hat{i}' = -\cos \theta \hat{i} + \sin \theta \hat{j}$ and $\hat{j}' = -\sin \theta \hat{i} - \cos \theta \hat{j}$. For $\theta = 30^\circ$, sketch the vector \vec{F} and show its components in the two coordinate systems.

2.48 Find the unit vectors \hat{e}_R and \hat{e}_θ in terms of \hat{i} and \hat{j} with the geometry shown in figure.

What are the components of \vec{W} along \hat{e}_R and \hat{e}_θ ?

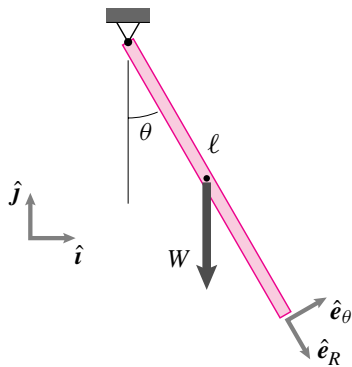

problem 2.48:

(Filename: pfigure2.vec1.44)

2.49 Write the position vector of point P in terms of $\hat{\lambda}_1$ and $\hat{\lambda}_2$ and

- find the y-component of \vec{r}_P ,
- find the component of \vec{r}_P along $\hat{\lambda}_1$.

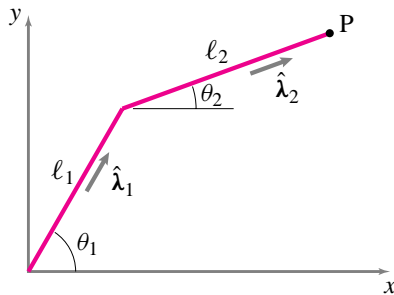

problem 2.49:

(Filename: pfigure2.vec1.45)

2.50 What is the distance between the point A and the diagonal BC of the parallelepiped shown? (Use vector methods.)

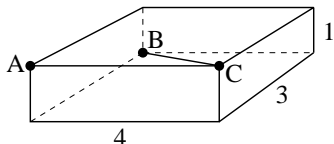

problem 2.50:

(Filename: pfigure.blue.2.3)

2.51 Let $\vec{F}_1 = 30\text{N}\hat{i} + 40\text{N}\hat{j} - 10\text{N}\hat{k}$, $\vec{F}_2 = -20\text{N}\hat{j} + 2\text{N}\hat{k}$, and $\vec{F}_3 = F_{3x}\hat{i} + F_{3y}\hat{j} - F_{3z}\hat{k}$. If the sum of all these forces must equal zero, find the required scalar equations to solve for the components of \vec{F}_3 .

2.52 A vector equation for the sum of forces results into the following equation:

$$\frac{F}{2}(\hat{i} - \sqrt{3}\hat{j}) + \frac{R}{5}(3\hat{i} + 6\hat{j}) = 25\text{N}\hat{\lambda}$$

where $\hat{\lambda} = 0.30\hat{i} - 0.954\hat{j}$. Find the scalar equations parallel and perpendicular to $\hat{\lambda}$.

2.53 Let $\alpha\vec{F}_1 + \beta\vec{F}_2 + \gamma\vec{F}_3 = \vec{0}$, where \vec{F}_1 , \vec{F}_2 , and \vec{F}_3 are as given in Problem 2.32. Solve for α , β , and γ using a computer.

2.54 Write a computer program (or use a canned program) to find the dot product of two 3-D vectors. Test the program by computing the dot products $\hat{i} \cdot \hat{i}$, $\hat{i} \cdot \hat{j}$, and $\hat{j} \cdot \hat{k}$. Now use the program to find the components of $\vec{F} = (2\hat{i} + 2\hat{j} - 3\hat{k})\text{N}$ along the line $\vec{r}_{AB} = (0.5\hat{i} - 0.2\hat{j} + 0.1\hat{k})\text{m}$.

2.55 Let $\vec{r}_n = 1\text{m}(\cos\theta_n\hat{i} + \sin\theta_n\hat{j})$, where $\theta_n = \theta_0 - n\Delta\theta$. Using a computer generate the required vectors and find the sum

$$\sum_{n=0}^{44} \vec{r}_n \quad \text{with } \Delta\theta = 1^\circ \text{ and } \theta_0 = 45^\circ.$$

2.3 Cross product, moment, and moment about an axis

2.56 Find the cross product of the two vectors shown in the figures below from the information given in the figures.

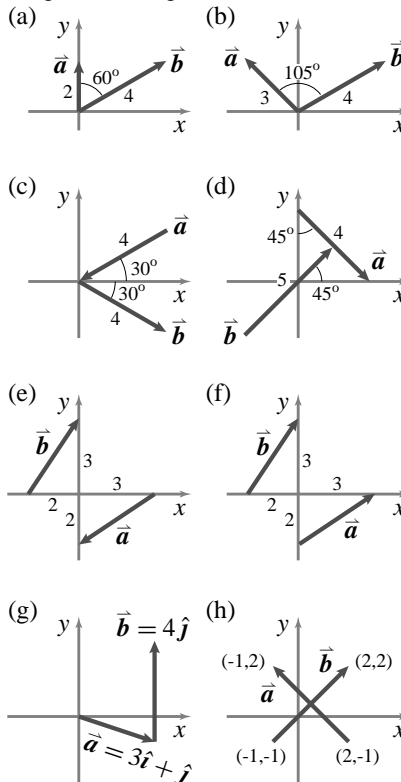

problem 2.56:

(Filename: pfigure2.vec2.1)

2.57 **Vector algebra.** For each equation below state whether:

- The equation is nonsense. If so, why?
- Is always true. Why? Give an example.
- Is never true. Why? Give an example.
- Is sometimes true. Give examples both ways.

You may use trivial examples.

- $\vec{B} \times \vec{C} = \vec{C} \times \vec{B}$
- $\vec{B} \times \vec{C} = \vec{C} \cdot \vec{B}$
- $\vec{C} \cdot (\vec{A} \times \vec{B}) = \vec{B} \cdot (\vec{C} \times \vec{A})$
- $\vec{A} \times (\vec{B} \times \vec{C}) = (\vec{A} \cdot \vec{C})\vec{B} - (\vec{A} \cdot \vec{B})\vec{C}$

2.58 What is the moment \vec{M} produced by a 20 N force F acting in the x direction with a lever arm of $\vec{r} = (16\text{mm})\hat{j}$?

2.59 Find the moment of the force shown on the rod about point O.

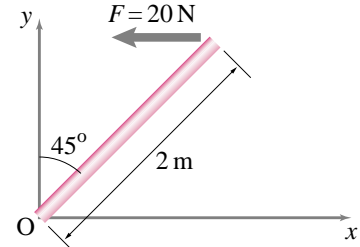

problem 2.59:

(Filename: pfigure2.vec2.2)

2.60 Find the sum of moments of forces \vec{W} and \vec{T} about the origin, given that $W = 100\text{N}$, $T = 120\text{N}$, $l = 4\text{m}$, and $\theta = 30^\circ$.

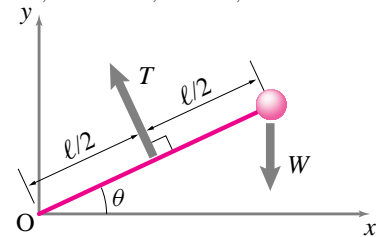

problem 2.60:

(Filename: pfigure2.vec2.3)

2.61 Find the moment of the force

- about point A
- about point O.

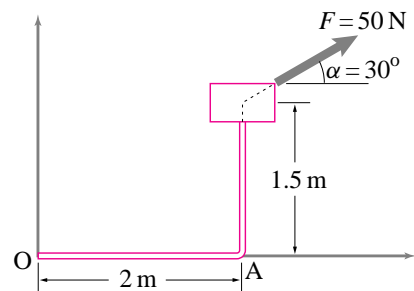

problem 2.61:

(Filename: pfigure2.vec2.4)

2.62 In the figure shown, $OA = AB = 2\text{m}$. The force $F = 40\text{N}$ acts perpendicular to the arm AB. Find the moment of \vec{F} about O, given that $\theta = 45^\circ$. If \vec{F} always acts normal to the arm AB, would increasing θ increase the magnitude of the moment? In particular, what value of θ will give the largest moment?

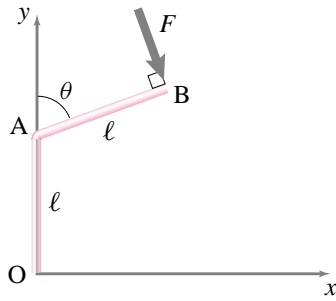

problem 2.62: (Filename:pfigure2.vec2.5)

2.63 Calculate the moment of the 2 kN payload on the robot arm about (i) joint A, and (ii) joint B, if $\ell_1 = 0.8$ m, $\ell_2 = 0.4$ m, and $\ell_3 = 0.1$ m.

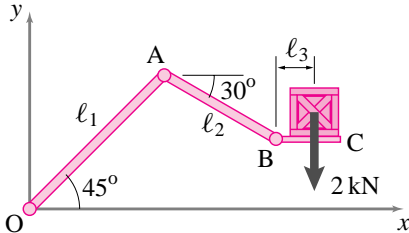

problem 2.63: (Filename:pfigure2.vec2.6)

2.64 During a slam-dunk, a basketball player pulls on the hoop with a 250 lbf at point C of the ring as shown in the figure. Find the moment of the force about

- the point of the ring attachment to the board (point B), and
- the root of the pole, point O.

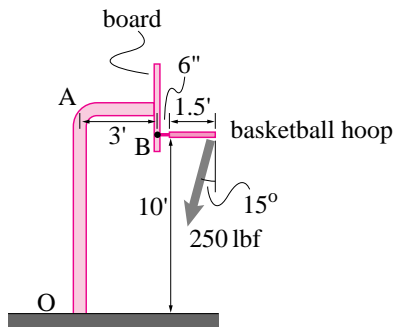

problem 2.64: (Filename:pfigure2.vec2.7)

2.65 During weight training, an athlete pulls a weight of 500 N with his arms pulling on a handlebar connected to a universal machine by a cable. Find the moment of the force about the shoulder joint O in the configuration shown.

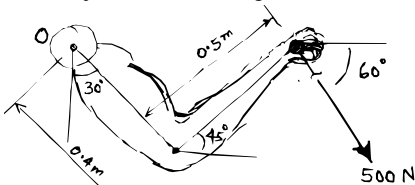

problem 2.65: (Filename:pfigure2.vec2.8)

2.66 Find the sum of moments due to the two weights of the teeter-totter when the teeter-totter is tipped at an angle θ from its vertical position. Give your answer in terms of the variables shown in the figure.

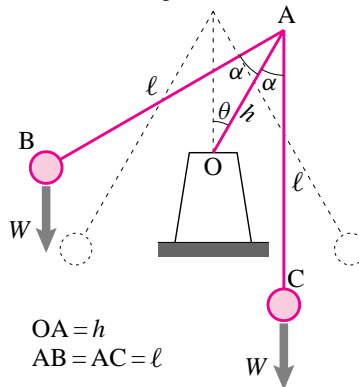

$OA = h$
 $AB = AC = \ell$

problem 2.66: (Filename:pfigure2.vec2.9)

2.67 Find the percentage error in computing the moment of \vec{W} about the pivot point O as a function of θ , if the weight is assumed to act normal to the arm OA (a good approximation when θ is very small).

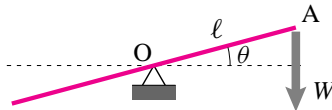

problem 2.67: (Filename:pfigure2.vec2.10)

2.68 What do you get when you cross a vector and a scalar? *

2.69 Why did the chicken cross the road? *

2.70 Carry out the following cross products in different ways and determine which method takes the least amount of time for you.

- $\vec{r} = 2.0\text{ft}\hat{i} + 3.0\text{ft}\hat{j} - 1.5\text{ft}\hat{k}$; $\vec{F} = -0.3\text{lb}\hat{i} - 1.0\text{lb}\hat{k}$; $\vec{r} \times \vec{F} = ?$
- $\vec{r} = (-\hat{i} + 2.0\hat{j} + 0.4\hat{k})\text{m}$; $\vec{L} = (3.5\hat{j} - 2.0\hat{k})\text{kg m/s}$; $\vec{r} \times \vec{L} = ?$
- $\vec{\omega} = (\hat{i} - 1.5\hat{j})\text{rad/s}$; $\vec{r} = (10\hat{i} - 2\hat{j} + 3\hat{k})\text{in}$; $\vec{\omega} \times \vec{r} = ?$

2.71 A force $\vec{F} = 20\text{N}\hat{j} - 5\text{N}\hat{k}$ acts through a point A with coordinates (200 mm, 300 mm, -100 mm). What is the moment $\vec{M} (= \vec{r} \times \vec{F})$ of the force about the origin?

2.72 Cross Product program Write a program that will calculate cross products. The input to the function should be the components of the two vectors and the output should be the components of the cross product. As a model, here is a function file that calculates dot products in pseudo code.

```
%program definition
z(1)=a(1)*b(1);
z(2)=a(2)*b(2);
z(3)=a(3)*b(3);
w=z(1)+z(2)+z(3);
```

2.73 Find a unit vector normal to the surface ABCD shown in the figure.

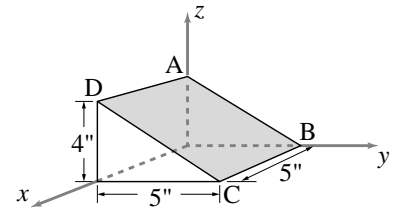

problem 2.73: (Filename:efig1.2.11)

2.74 If the magnitude of a force \vec{N} normal to the surface ABCD in the figure is 1000 N, write \vec{N} as a vector. *

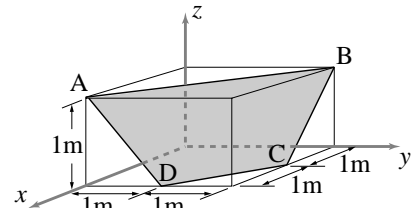

problem 2.74: (Filename:efig1.2.12)

2.75 The equation of a surface is given as $z = 2x - y$. Find a unit vector \hat{n} normal to the surface.

2.76 In the figure, a triangular plate ACB, attached to rod AB, rotates about the z-axis. At the instant shown, the plate makes an angle of 60° with the x-axis. Find and draw a vector normal to the surface ACB.

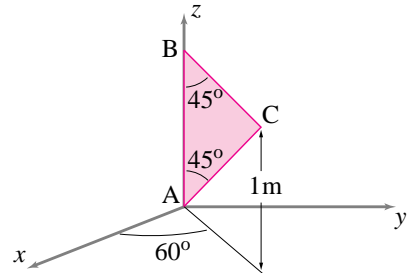

problem 2.76: (Filename:efig1.2.14)

2.77 What is the distance d between the origin and the line AB shown? (You may write your solution in terms of \vec{A} and \vec{B} before doing any arithmetic). *

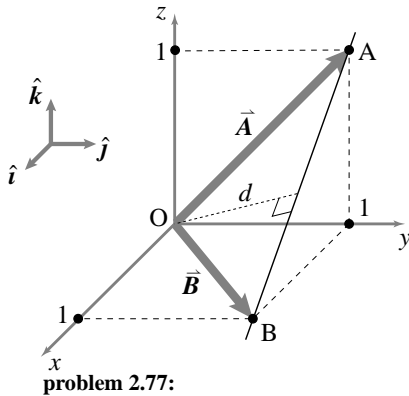

problem 2.77:

(Filename: pfigure.blue.1.3)

2.78 What is the perpendicular distance between the point A and the line BC shown? (There are at least 3 ways to do this using various vector products, how many ways can you find?)

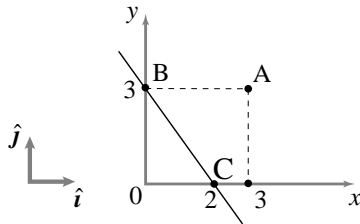

problem 2.78:

(Filename: pfigure.blue.2.2)

2.79 Given a force, $\vec{F}_1 = (-3\hat{i} + 2\hat{j} + 5\hat{k})$ N acting at a point P whose position is given by $\vec{r}_{P/O} = (4\hat{i} - 2\hat{j} + 7\hat{k})$ m, what is the moment about an axis through the origin O with direction $\hat{\lambda} = \frac{2}{\sqrt{5}}\hat{j} + \frac{1}{\sqrt{5}}\hat{j}$?

2.80 Drawing vectors and computing with vectors. The point O is the origin. Point A has xyz coordinates (0, 5, 12)m. Point B has xyz coordinates (4, 5, 12)m.

- Make a neat sketch of the vectors OA, OB, and AB.
- Find a unit vector in the direction of OA, call it $\hat{\lambda}_{OA}$.
- Find the force \vec{F} which is 5N in size and is in the direction of OA.
- What is the angle between OA and OB?
- What is $\vec{r}_{BO} \times \vec{F}$?
- What is the moment of \vec{F} about a line parallel to the z axis that goes through the point B?

2.81 Vector Calculations and Geometry. The 5N force \vec{F}_1 is along the line OA. The 7N force \vec{F}_2 is along the line OB.

- Find a unit vector in the direction OB. *
- Find a unit vector in the direction OA. *

- Write both \vec{F}_1 and \vec{F}_2 as the product of their magnitudes and unit vectors in their directions. *
- What is the angle AOB? *
- What is the component of \vec{F}_1 in the x-direction? *
- What is $\vec{r}_{DO} \times \vec{F}_1$? ($\vec{r}_{DO} \equiv \vec{r}_{O/D}$ is the position of O relative to D.) *
- What is the moment of \vec{F}_2 about the axis DC? (The moment of a force about an axis parallel to the unit vector $\hat{\lambda}$ is defined as $M_\lambda = \hat{\lambda} \cdot (\vec{r} \times \vec{F})$ where \vec{r} is the position of the point of application of the force relative to some point on the axis. The result does not depend on which point on the axis is used or which point on the line of action of \vec{F} is used.) *

h) Repeat the last problem using either a different reference point on the axis DC or the line of action OB. Does the solution agree? [Hint: it should.] *

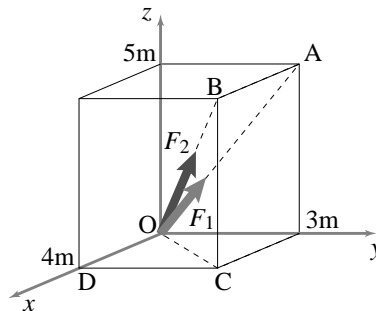

problem 2.81:

(Filename: p1sp92)

2.82 A, B, and C are located by position vectors $\vec{r}_A = (1, 2, 3)$, $\vec{r}_B = (4, 5, 6)$, and $\vec{r}_C = (7, 8, 9)$.

- Use the vector dot product to find the angle BAC (A is at the vertex of this angle).
- Use the vector cross product to find the angle BCA (C is at the vertex of this angle).
- Find a unit vector perpendicular to the plane ABC.
- How far is the infinite line defined by AB from the origin? (That is, how close is the closest point on this line to the origin?)
- Is the origin co-planar with the points A, B, and C?

2.83 Points A, B, and C in the figure define a plane.

- Find a unit normal vector to the plane. *
- Find the distance from this infinite plane to the point D. *

c) What are the coordinates of the point on the plane closest to point D? *

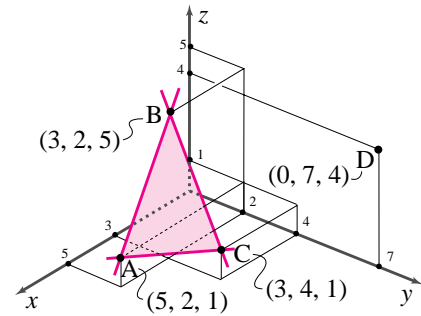

problem 2.83:

(Filename: pfigure.s95q2)

2.4 Equivalent force systems and couples

2.84 Find the net force on the particle shown in the figure.

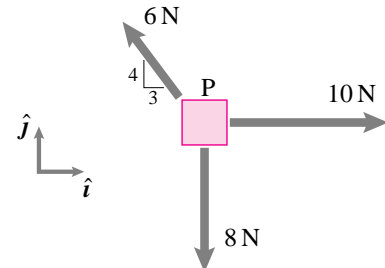

problem 2.84:

(Filename: pfigure.2.3.rp1)

2.85 Replace the forces acting on the particle of mass m shown in the figure by a single equivalent force.

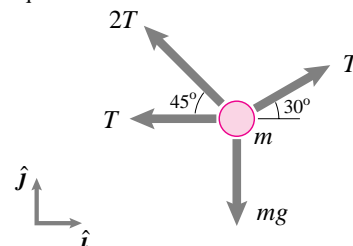

problem 2.85:

(Filename: pfigure.2.3.rp2)

2.86 Find the net force on the pulley due to the belt tensions shown in the figure.

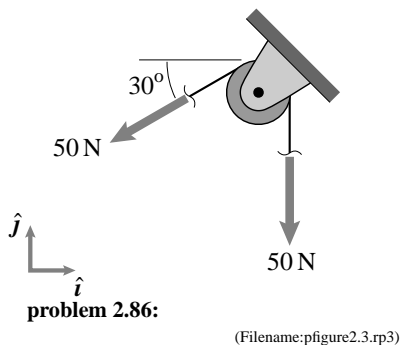

2.87 Replace the forces shown on the rectangular plate by a single equivalent force. Where should this equivalent force act on the plate and why?

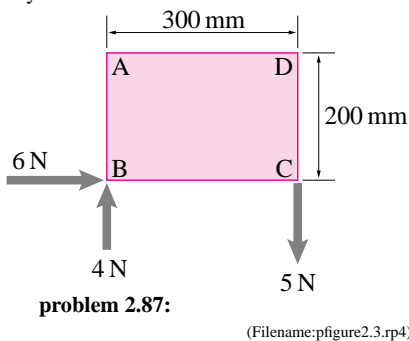

2.88 Three forces act on a Z-section ABCDE as shown in the figure. Point C lies in the middle of the vertical section BD. Find an equivalent force-couple system acting on the structure and make a sketch to show where it acts.

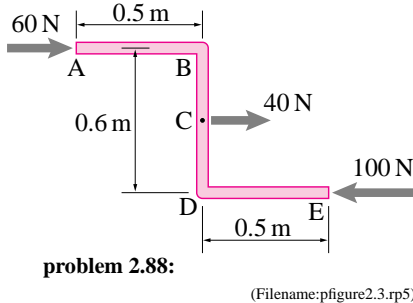

2.89 The three forces acting on the circular plate shown in the figure are equidistant from the center C. Find an equivalent force-couple system acting at point C.

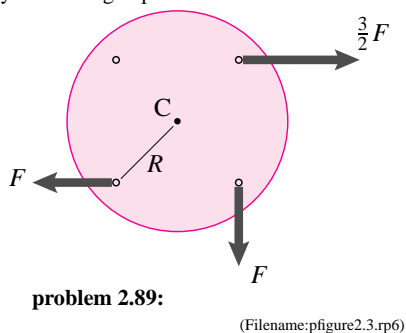

2.90 The forces and the moment acting on point C of the frame ABC shown in the figure are $C_x = 48 \text{ N}$, $C_y = 40 \text{ N}$, and $M_c = 20 \text{ N}\cdot\text{m}$. Find an equivalent force couple system at point B.

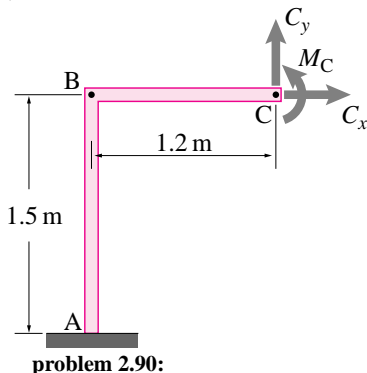

2.91 Find an equivalent force-couple system for the forces acting on the beam in Fig. ??, if the equivalent system is to act at

- a) point B,
- b) point D.

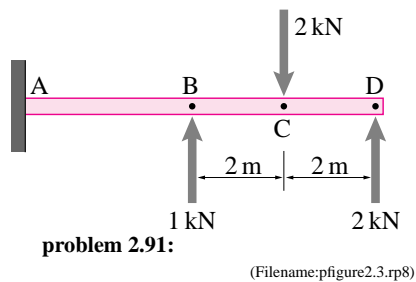

2.92 In Fig. ??, three different force-couple systems are shown acting on a square plate. Identify which force-couple systems are equivalent.

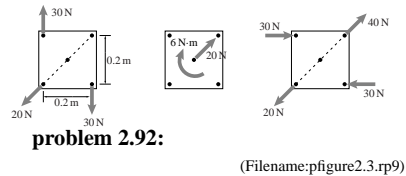

2.93 The force and moment acting at point C of a machine part are shown in the figure where M_c is not known. It is found that if the given force-couple system is replaced by a single horizontal force of magnitude 10 N acting at point A then the net effect on the machine part is the same. What is the magnitude of the moment M_c ?

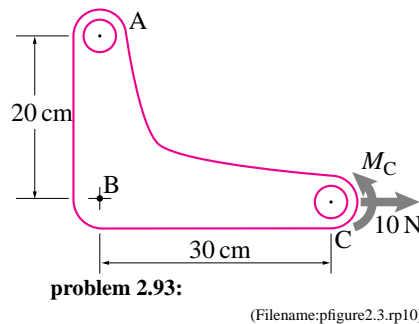

2.5 Center of mass and center of gravity

2.94 An otherwise massless structure is made of four point masses, m , $2m$, $3m$ and $4m$, located at coordinates $(0, 1 \text{ m})$, $(1 \text{ m}, 1 \text{ m})$, $(1 \text{ m}, -1 \text{ m})$, and $(0, -1 \text{ m})$, respectively. Locate the center of mass of the structure. *

2.95 3-D: The following data is given for a structural system modeled with five point masses in 3-D-space:

mass	coordinates (in m)
0.4 kg	(1,0,0)
0.4 kg	(1,1,0)
0.4 kg	(2,1,0)
0.4 kg	(2,0,0)
1.0 kg	(1.5,1.5,3)

Locate the center of mass of the system.

2.96 Write a computer program to find the center of mass of a point-mass-system. The input to the program should be a table (or matrix) containing individual masses and their coordinates. (It is possible to write a single program for both 2-D and 3-D cases, write separate programs for the two cases if that is easier for you.) Check your program on Problems 2.94 and 2.95.

2.97 Find the center of mass of the following composite bars. Each composite shape is made of two or more uniform bars of length 0.2 m and mass 0.5 kg.

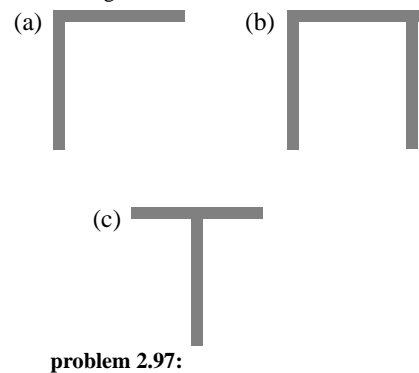

2.98 Find the center of mass of the following two objects [Hint: set up and evaluate the needed integrals.]

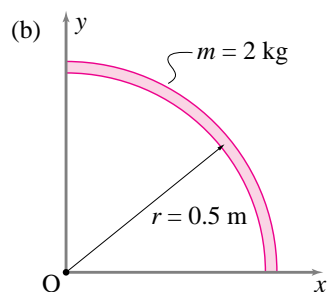
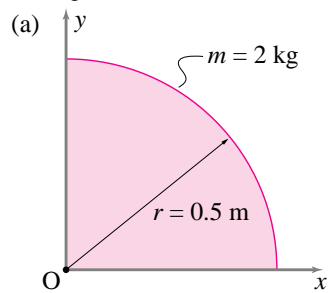

problem 2.98:

(Filename:pfigure3.cm.rp8)

2.99 Find the center of mass of the following plates obtained from cutting out a small section from a uniform circular plate of mass 1 kg (prior to removing the cutout) and radius $1/4$ m.

(a) 200 mm x 200 mm

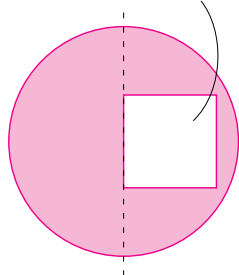

(b) $r = 100$ mm

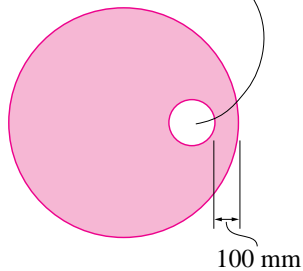

problem 2.99:

(Filename:pfigure3.cm.rp9)

Problems for Chapter 3

Free body diagrams

3.1 Free body diagrams

3.1 How does one know what forces and moments to use in

- a) the statics force balance and moment balance equations?
- b) the dynamics linear momentum balance and angular momentum balance equations?

3.2 A point mass m is attached to a piston by two inextensible cables. There is gravity. Draw a free body diagram of the mass with a little bit of the cables.

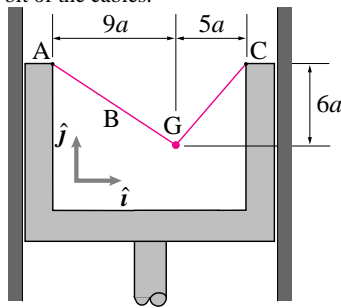

problem 3.2: (Filename: pfigure2.1.suspended.mass)

3.3 Simple pendulum. For the simple pendulum shown the “body”—the system of interest—is the mass and a little bit of the string. Draw a free body diagram of the system.

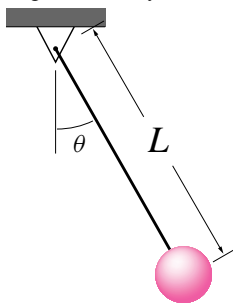

problem 3.3: (Filename: pfigure.s94h2p1)

3.4 Draw a free body diagram of mass m at the instant shown in the figure. Evaluate the left hand side of the linear momentum balance equation ($\sum \vec{F} = m\vec{a}$) as explicitly as possible. Identify the unknowns in the expression.

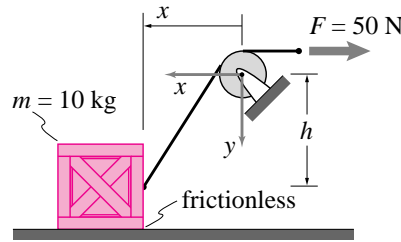

problem 3.4: (Filename: pfig2.2.rp1)

3.5 A 1000 kg satellite is in orbit. Its speed is v and its distance from the center of the earth is R . Draw a free body diagram of the satellite. Draw another that takes account of the slight drag force of the earth’s atmosphere on the satellite.

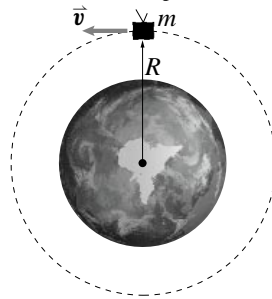

problem 3.5: (Filename: pfigure.s94h2p5)

3.6 The uniform rigid rod shown in the figure hangs in the vertical plane with the support of the spring shown. Draw a free body diagram of the rod.



problem 3.6: (Filename: pfig2.1.rp1)

3.7 FBD of rigid body pendulum. The rigid body pendulum in the figure is a uniform rod of mass m . Draw a free body diagram of the rod.

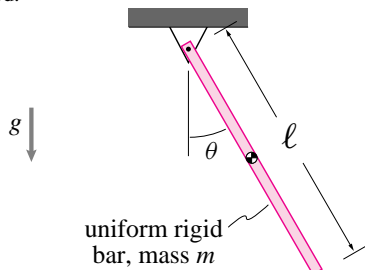

problem 3.7: (Filename: pfigure2.rod.pend.fbd)

3.8 A thin rod of mass m rests against a frictionless wall and on a frictionless floor. There is gravity. Draw a free body diagram of the rod.

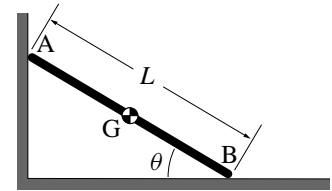

problem 3.8: (Filename: ch2.6)

3.9 A uniform rod of mass m rests in the back of a flatbed truck as shown in the figure. Draw a free body diagram of the rod, set up a suitable coordinate system, and evaluate $\sum \vec{F}$ for the rod.

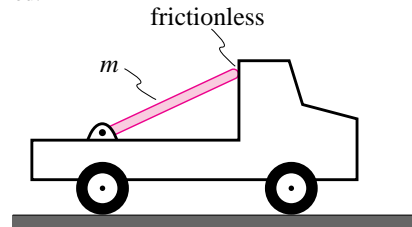

problem 3.9: (Filename: pfig2.2.rp5)

3.10 A disc of mass m sits in a wedge shaped groove. There is gravity and negligible friction. The groove that the disk sits in is part of an assembly that is still. Draw a free body diagram of the disk. (See also problems 4.15 and 6.47.)

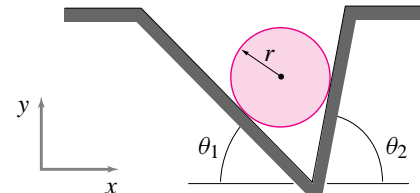

problem 3.10: (Filename: ch2.5)

3.11 A pendulum, made up of a mass m attached at the end of a rigid massless rod of length ℓ , hangs in the vertical plane from a hinge. The pendulum is attached to a spring and a dashpot on each side at a point $\ell/4$ from the hinge point. Draw a free body diagram of the pendulum (mass and rod system) when the pendulum is slightly away from the vertical equilibrium position.

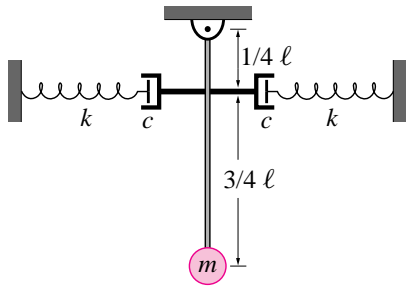

problem 3.11: (Filename:pfig2.1.rp5)

3.12 The left hand side of the angular momentum balance (Torque balance in statics) equation requires the evaluation of the sum of moments about some point. Draw a free body diagram of the rod shown in the figure and compute $\sum \vec{M}_O$ as explicitly as possible. Now compute $\sum \vec{M}_C$. How many unknown forces does each equation contain?

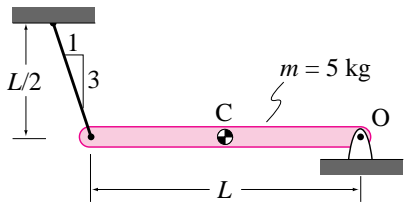

problem 3.12: (Filename:pfig2.2.rp3)

3.13 A block of mass m is sitting on a frictionless surface at points A and B and acted upon at point E by the force P . There is gravity. Draw a free body diagram of the block.

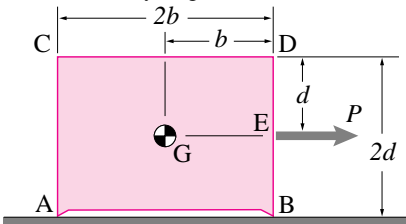

problem 3.13: (Filename:ch2.1)

3.14 A mass-spring system sits on a conveyer belt. The spring is fixed to the wall on one end. The belt moves to the right at a constant speed v_0 . The coefficient of friction between the mass and the belt is μ . Draw a free body diagram of the mass assuming it is moving to the left at the time of interest.

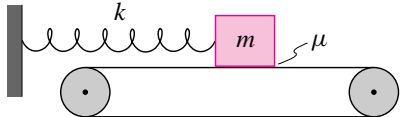

problem 3.14: (Filename:pfig2.1.rp6)

3.15 A small block of mass m slides down an incline with coefficient of friction μ . At an instant in time t during the motion, the block has speed v . Draw a free body diagram of the block.

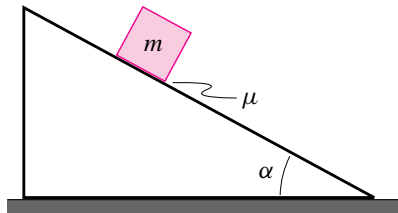

problem 3.15: (Filename:pfig2.3.rp5)

3.16 Assume that the wheel shown in the figure rolls without slipping. Draw a free body diagram of the wheel and evaluate $\sum \vec{F}$ and $\sum \vec{M}_C$. What would be different in the expressions obtained if the wheel were slipping?

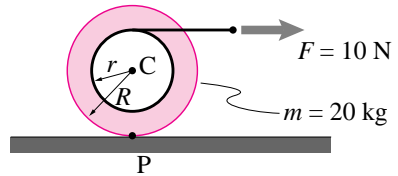

problem 3.16: (Filename:pfig2.2.rp4)

3.17 A compound wheel with inner radius r and outer radius R is pulled to the right by a 10 N force applied through a string wound around the inner wheel. Assume that the wheel rolls to the right without slipping. Draw a free body diagram of the wheel.

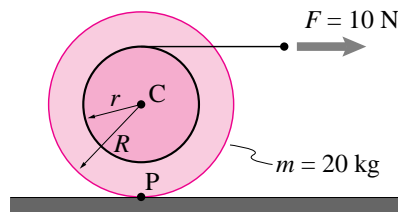

problem 3.17: (Filename:pfig2.1.rp8)

3.18 A block of mass m is sitting on a frictional surface and acted upon at point E by the horizontal force P through the center of mass. The block is resting on sharp edge at point B and is supported by a small ideal wheel at point A . There is gravity. Draw a free body diagram of the block including the wheel, assuming the block is sliding to the right with coefficient of friction μ at point B .

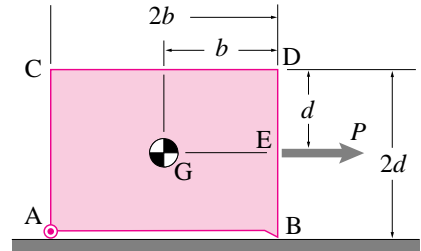

problem 3.18: (Filename:ch2.2)

3.19 A spring-mass model of a mechanical system consists of a mass connected to three springs and a dashpot as shown in the figure. The wheels against the wall are in tracks (not shown) that do not let the wheels lift off the wall so the mass is constrained to move only in the vertical direction. Draw a free body diagram of the system.

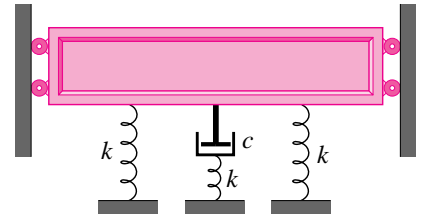

problem 3.19: (Filename:pfig2.1.rp2)

3.20 A point mass of mass m moves on a frictionless surface and is connected to a spring with constant k and unstretched length ℓ . There is gravity. At the instant of interest, the mass has just been released at a distance x to the right from its position where the spring is unstretched.

- Draw a free body diagram of the mass and spring together at the instant of interest.
- Draw free body diagrams of the mass and spring separately at the instant of interest.

(See also problem 5.32.)

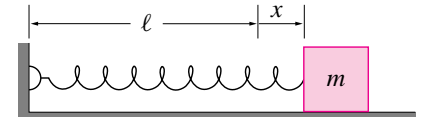

problem 3.20: (Filename:ch2.10)

3.21 FBD of a block. The block of mass 10 kg is pulled by an inextensible cable over the pulley.

- Assuming the block remains on the floor, draw a free diagram of the block.
- Draw a free body diagram of the pulley and a little bit of the cable that rides over it.

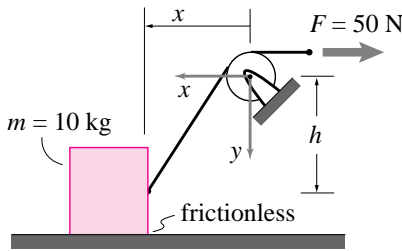

problem 3.21:
(Filename:pfigure2.1.block.pulley)

3.22 A pair of falling masses. Two masses A & B are spinning around each other and falling towards the ground. A string, which you can assume to be taught, connects the two masses. A snapshot of the system is shown in the figure. Draw free body diagrams of

- mass A with a little bit of string,
- mass B with a little bit of string, and
- the whole system.

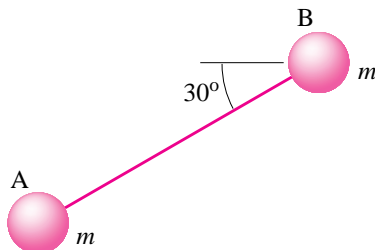

problem 3.22:
(Filename:pfigure.s94h2p4)

3.23 A two-degree of freedom spring-mass system is shown in the figure. Draw free body diagrams of each mass separately and then the two masses together.

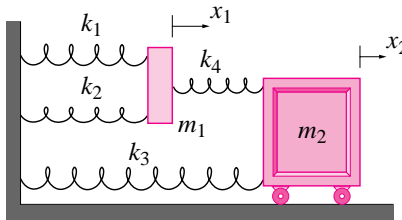

problem 3.23:
(Filename:pfig2.1.rp4)

3.24 The figure shows a spring-mass model of a structure. Assume that the three masses are displaced to the right by x_1 , x_2 and x_3 from the static equilibrium configuration such that $x_1 < x_2 < x_3$. Draw free body diagrams of each mass and evaluate $\sum \vec{F}$ in each case. Ignore gravity.

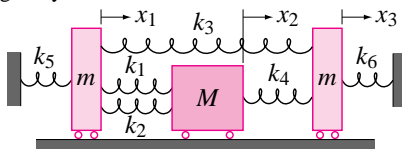

problem 3.24:
(Filename:pfig2.2.rp10)

3.25 In the system shown, assume that the two masses A and B move together (i.e., no relative slip). Draw a free body diagram of mass A and evaluate the left hand side of the linear momentum balance equation. Repeat the procedure for the system consisting of both masses.

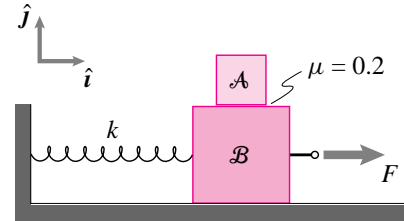

problem 3.25:
(Filename:pfig2.2.rp2)

3.26 Two identical rigid rods are connected together by a pin. The vertical stiffness of the system is modeled by three springs as shown in the figure. Draw free body diagrams of each rod separately. [This problem is a little tricky and there is more than one reasonable answer.]

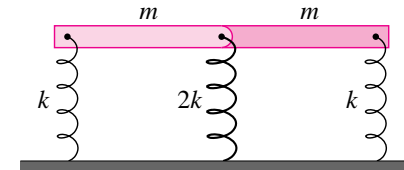

problem 3.26:
(Filename:pfig2.1.rp3)

3.27 A uniform rod rests on a cart which is being pulled to the right. The rod is hinged at one end (with a frictionless hinge) and has no friction at the contact with the cart. The cart rolls on massless wheels that have no bearing friction (ideal massless wheels). Draw FBD's of

- the rod,
- the cart, and
- the whole system.

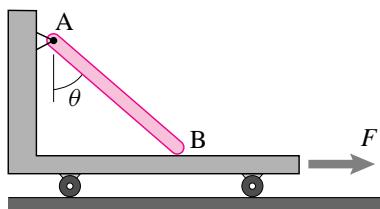

problem 3.27:
(Filename:pfigure.s94h2p6)

3.28 FBD's of simple pendulum and its parts. The simple pendulum in the figure is composed of a rod of negligible mass and a pendulum bob of mass m .

- Draw a free body diagram of the pendulum bob.
- Draw a free body diagram of the rod.
- Draw a free body diagram of the rod and pendulum bob together.

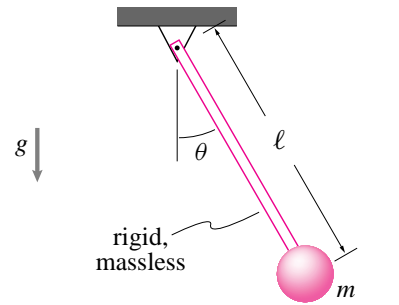

problem 3.28:
(Filename:pfigure2.simp.pend.fbd)

3.29 For the double pendulum shown in the figure, evaluate $\sum \vec{F}$ and $\sum \vec{M}_O$ at the instant shown in terms of the given quantities and unknown forces (if any) on the bar.

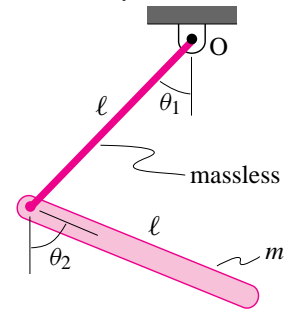

problem 3.29:
(Filename:pfig2.2.rp6)

3.30 See also problem 11.4. Two frictionless blocks sit stacked on a frictionless surface. A force F is applied to the top block. There is gravity.

- Draw a free body diagram of the two blocks together and a free body diagram of each block separately.

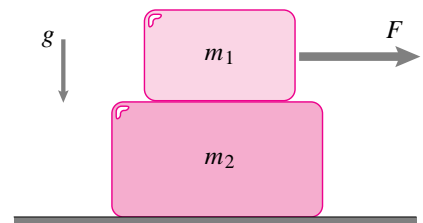

problem 3.30:
(Filename:ch2.3)

3.31 For the system shown in the figure draw free body diagrams of each mass separately assuming that there is no relative slip between the two masses.

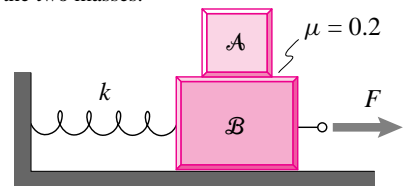

problem 3.31:
(Filename:pfig2.1.rp7)

3.32 Two frictionless prisms of similar right triangular sections are placed on a frictionless horizontal plane. The top prism weighs W and the lower one, nW . Draw free body diagrams of

- the system of prisms and
- each prism separately.

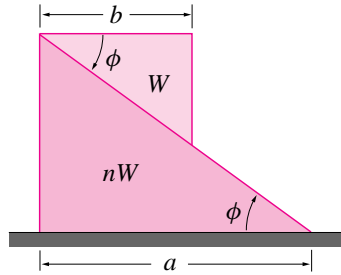

problem 3.32:

(Filename:pfigure.blue.28.2)

3.33 In the slider crank mechanism shown, draw a free body diagram of the crank and evaluate $\sum \vec{F}$ and $\sum \vec{M}_O$ as explicitly as possible.

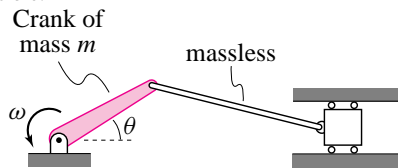

problem 3.33:

(Filename:pfig2.2.rp9)

3.34 FBD of an arm throwing a ball. An arm throws a ball up. A crude model of an arm is that it is made of four rigid bodies (shoulder, upper arm, forearm and a hand) that are connected with hinges. At each hinge there are muscles that apply torques between the links. Draw a FBD of

- the ball, the shoulder (fixed to the wall),
- the upper arm,
- the fore-arm,
- the hand, and
- the whole arm (all four parts) including the ball.

Write the equation of angular momentum balance about the shoulder joint A, evaluating the left-hand-side as explicitly as possible.

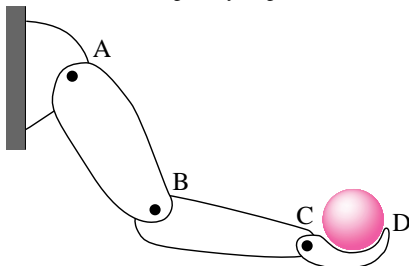

problem 3.34:

(Filename:efig2.1.23)

3.35 An imagined testing machine consists of a box fastened to a wheel as shown. The box always moves so that its floor is parallel to the ground (like an empty car on a Ferris Wheel). Two identical masses, A and B are connected together by cords 1 and 2 as shown. The floor of the box is frictionless. The machine and blocks are set in motion when $\theta = 0^\circ$, with constant $\dot{\theta} = 3 \text{ rad/s}$. Draw free body diagrams of:

- the system consisting of the box, blocks, and wheel,
- the system of box and blocks,
- the system of blocks and cords,
- the system of box, block B, cord 2, and a portion of cord 1 and,
- the box and blocks separately.

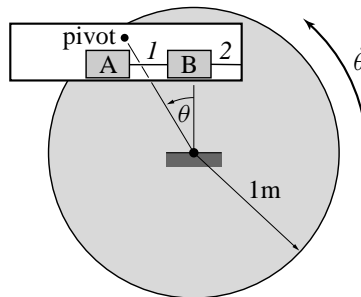

problem 3.35:

(Filename:pfigure.blue.52.1)

3.36 Free body diagrams of a double 'physical' pendulum. A double pendulum is a system where one pendulum hangs from another. Draw free body diagrams of various subsystems in a typical configuration.

- Draw a free body diagram of the lower stick, the upper stick, and both sticks in arbitrary configurations.
- Repeat part (a) but use the simplifying assumption that the upper bar has negligible mass.

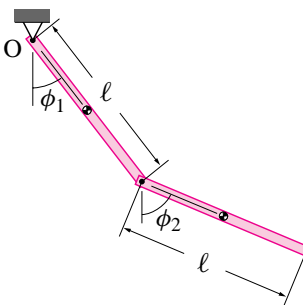

problem 3.36:

(Filename:pfigure.s94h2p3)

3.37 The strings hold up the mass $m = 3 \text{ kg}$. There is gravity. Draw a free body diagram of the mass.

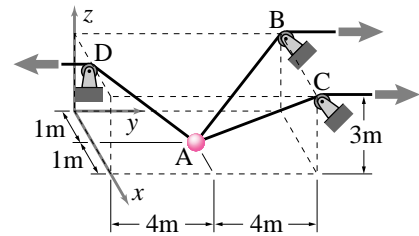

problem 3.37:

(Filename:pfigure2.1.3D.pulley.fbd)

3.38 Mass on inclined plane. A block of mass m rests on a frictionless inclined plane. It is supported by two stretched springs. The mass is pulled down the plane by an amount δ and released. Draw a FBD of the mass just after it is released.

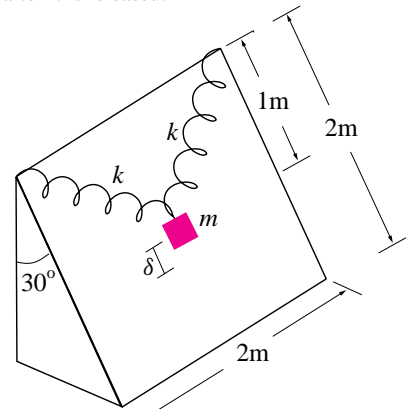

problem 3.38:

(Filename:efig2.1.24)

3.39 Hanging a shelf. A shelf with negligible mass supports a 0.5 kg mass at its center. The shelf is supported at one corner with a ball and socket joint and the other three corners with strings. At the moment of interest the shelf is in a rocket in outer space and accelerating at 10 m/s^2 in the \hat{k} direction. The shelf is in the xy plane. Draw a FBD of the shelf.

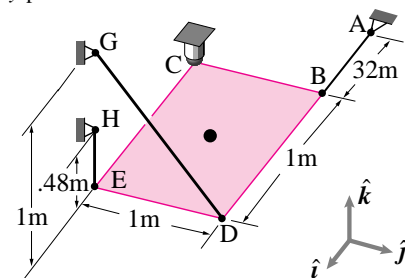

problem 3.39:

(Filename:ch3.14)

3.40 A massless triangular plate rests against a frictionless wall at point D and is rigidly attached to a massless rod supported by two ideal bearings. A ball of mass m is fixed to the centroid of the plate. There is gravity. Draw a free body diagram of the plate, ball, and rod as a system.

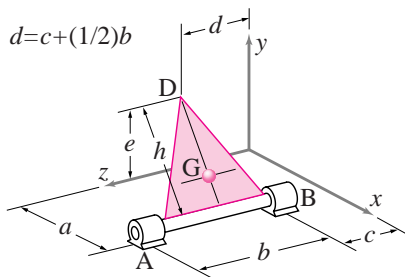

problem 3.40:

(Filename:ch2.9)

3.41 An undriven massless disc rests on its edge on a frictional surface and is attached rigidly by a weld at point C to the end of a rod that pivots at its other end about a ball-and-socket joint at point O. There is gravity.

- a) Draw a free body diagram of the disc and rod together.
- b) Draw free body diagrams of the disc and rod separately.
- c) What would be different in the free body diagram of the rod if the ball-and-socket was rusty (not ideal)?

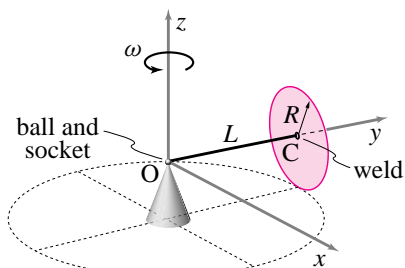

problem 3.41:

(Filename:ch2.7)

Problems for Chapter 4

Statics

4.1 Static equilibrium of one body

4.1 To evaluate the equation $\sum \vec{F} = m\vec{a}$ for some problem, a student writes $\sum \vec{F} = F_x \hat{i} - (F_y - 30\text{N})\hat{j} + 50\text{N}\hat{k}$ in the xyz coordinate system, but $\vec{a} = 2.5\text{m/s}^2 \hat{i}' + 1.8\text{m/s}^2 \hat{j}' - a_z \hat{k}'$ in a rotated $x'y'z'$ coordinate system. If $\hat{i}' = \cos 60^\circ \hat{i} + \sin 60^\circ \hat{j}$, $\hat{j}' = -\sin 60^\circ \hat{i} + \cos 60^\circ \hat{j}$ and $\hat{k}' = \hat{k}$, find the scalar equations for the x' , y' , and z' directions.

4.2 N small blocks each of mass m hang vertically as shown, connected by N inextensible strings. Find the tension T_n in string n . *

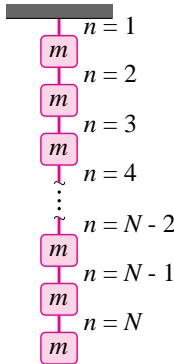

problem 4.2:

(Filename:pfigure2.hanging.masses)

4.3 See also problem 7.98. A zero length spring (relaxed length $\ell_0 = 0$) with stiffness $k = 5\text{N/m}$ supports the pendulum shown. Assume $g = 10\text{N/m}$. Find θ for static equilibrium. *

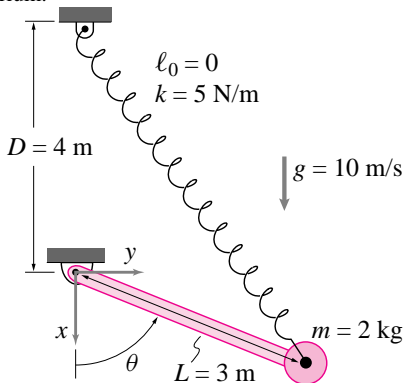

problem 4.3:

(Filename:pfigure2.blue.80.2.a)

4.4 What force should be applied to the end of the string over the pulley at C so that the mass at A is at rest?

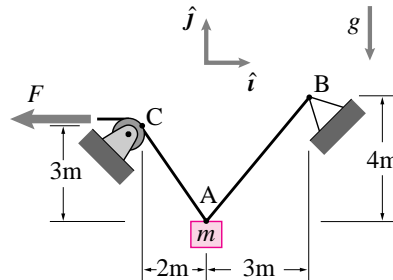

problem 4.4:

(Filename:f92h1p1.a)

4.2 Elementary truss analysis

The first set of problems concerns math skills that can be used to help solve truss problems. If computer solution is not going to be used, the following problems can be skipped.

4.5 Write the following equations in matrix form to solve for x , y , and z :

$$\begin{aligned} 2x - 3y + 5 &= 0, \\ y + 2\pi z &= 21, \\ \frac{1}{3}x - 2y + \pi z - 11 &= 0. \end{aligned}$$

4.6 Are the following equations linearly independent?

- $x_1 + 2x_2 + x_3 = 30$
- $3x_1 + 6x_2 + 9x_3 = 4.5$
- $2x_1 + 4x_2 + 15x_3 = 7.5$.

4.7 Write computer commands (or a program) to solve for x , y and z from the following equations with r as an input variable. Your program should display an error message if, for a particular r , the equations are not linearly independent.

- $5x + 2ry + z = 2$
- $3x + 6y + (2r - 1)z = 3$
- $2x + (r - 1)y + 3rz = 5$.

Find the solutions for $r = 3, 4.99$, and 5 .

4.8 An exam problem in statics has three unknown forces. A student writes the following three equations (he knows that he needs three equations for three unknowns!) — one for the force balance in the x -direction and the other two for the moment balance about two different points.

- $F_1 - \frac{1}{2}F_2 + \frac{1}{\sqrt{2}}F_3 = 0$
- $2F_1 + \frac{3}{2}F_2 = 0$
- $\frac{5}{2}F_2 + \sqrt{2}F_3 = 0$.

Can the student solve for F_1 , F_2 , and F_3 uniquely from these equations? *

4.9 What is the solution to the set of equations:

$$\begin{aligned} x + y + z + w &= 0 \\ x - y + z - w &= 0 \\ x + y - z - w &= 0 \\ x + y + z - w &= 2? \end{aligned}$$

4.3 Advanced truss analysis: determinacy, rigidity, and redundancy

4.4 Internal forces

4.5 Springs

4.10 What is the stiffness of two springs in parallel?

4.11 What is the stiffness of two springs in series?

4.12 What is the apparent stiffness of a pendulum when pushed sideways.

4.13 Optimize a triangular truss for stiffness and for strength and show that the resulting design is not the same.

4.6 Structures and machines

4.14 See also problems 6.18 and 6.19. Find the ratio of the masses m_1 and m_2 so that the system is at rest.

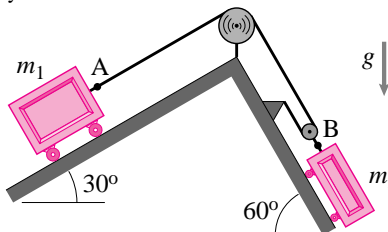

problem 4.14: (Filename:pulley4.c)

4.15 (See also problem 6.47.) What are the forces on the disk due to the groove? Define any variables you need.

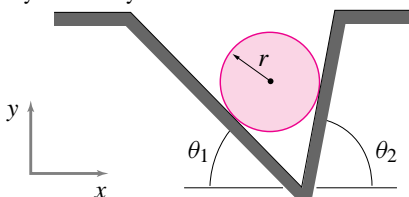

problem 4.15: (Filename:ch2.5.b)

4.16 Two gears at rest. See also problems 7.77 and ???. At the input to a gear box, a 100 lbf force is applied to gear A. At the output, the machinery (not shown) applies a force of F_B to the output gear. Assume the system of gears is at rest. What is F_B ?

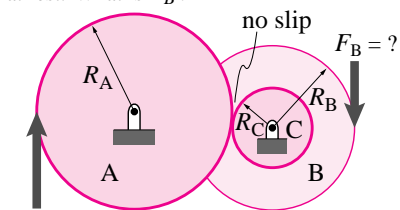

problem 4.16: Two gears. (Filename:pg131.3.a)

4.17 See also problem 4.18. A reel of mass M and outer radius R is connected by a horizontal string from point P across a pulley to a hanging object of mass m . The inner cylinder of the reel has radius $r = \frac{1}{2}R$. The slope has angle θ . There is no slip between the reel and the slope. There is gravity.

- Find the ratio of the masses so that the system is at rest. *
- Find the corresponding tension in the string, in terms of M , g , R , and θ . *
- Find the corresponding force on the reel at its point of contact with the slope, point C , in terms of M , g , R , and θ . *

d) Another look at equilibrium. [Harder] Draw a careful sketch and find a point where the lines of action of the gravity force and string tension intersect. For the reel to be in static equilibrium, the line of action of the reaction force at C must pass through this point. Using this information, what must the tangent of the angle ϕ of the reaction force at C be, measured with respect to the normal to the slope? Does this answer agree with that you would obtain from your answer in part(c)? *

e) What is the relationship between the angle ψ of the reaction at C , measured with respect to the normal to the ground, and the mass ratio required for static equilibrium of the reel? *

Check that for $\theta = 0$, your solution gives $\frac{m}{M} = 0$ and $\vec{F}_C = Mg\hat{j}$ and for $\theta = \frac{\pi}{2}$, it gives $\frac{m}{M} = 2$ and $\vec{F}_C = Mg(\hat{i} + 2\hat{j})$.

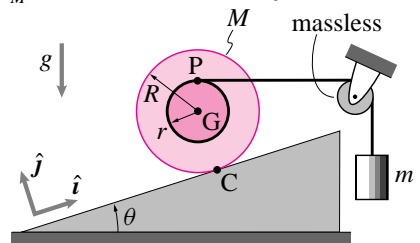

problem 4.17: (Filename:pfigure2.blue.47.3.a)

4.18 This problem is identical to problem 4.17 except for the location of the connection point of the string to the reel, point P . A reel of mass M and outer radius R is connected by an inextensible string from point P across a pulley to a hanging object of mass m . The inner cylinder of the reel has radius $r = \frac{1}{2}R$. The slope has angle θ . There is no slip between the reel and the slope. There is gravity. In terms of M , m , R , and θ , find:

- the ratio of the masses so that the system is at rest, *
- the corresponding tension in the string, and *
- the corresponding force on the reel at its point of contact with the slope, point C . *

Check that for $\theta = 0$, your solution gives $\frac{m}{M} = 0$ and $\vec{F}_C = Mg\hat{j}$ and for $\theta = \frac{\pi}{2}$, it gives $\frac{m}{M} = -2$ and $\vec{F}_C = Mg(\hat{i} - 2\hat{j})$. The negative mass ratio is impossible since mass cannot be negative and the negative normal force is impossible unless the wall or the reel or both can 'suck' or they can 'stick' to each other (that is, provide some sort of suction, adhesion, or magnetic attraction).

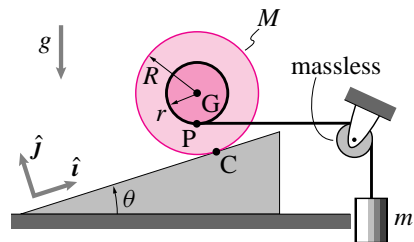

problem 4.18: (Filename:pfigure2.blue.47.3.b)

4.19 Two racks connected by three gears at rest. See also problem 7.86. A 100 lbf force is applied to one rack. At the output, the machinery (not shown) applies a force of F_B to the other rack. Assume the gear-train is at rest. What is F_B ?

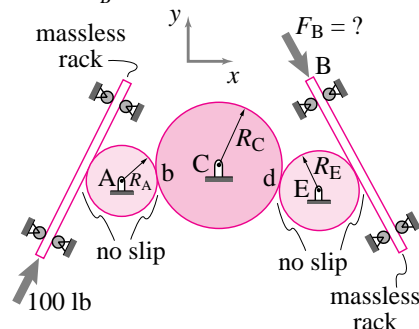

problem 4.19: Two racks connected by three gears. (Filename:ch4.5.a)

4.20 In the flyball governor shown, the mass of each ball is $m = 5$ kg, and the length of each link is $\ell = 0.25$ m. There are frictionless hinges at points A, B, C, D, E, F where the links are connected. The central collar has mass $m/4$. Assuming that the spring of constant $k = 500$ N/m is uncompressed when $\theta = \pi$ radians, what is the compression of the spring?

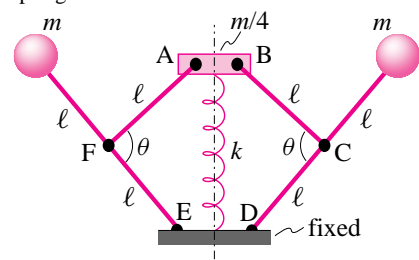

problem 4.20: (Filename:summer95p2.2.a)

4.21 Assume a massless pulley is round and has outer radius R_2 . It slides on a shaft that has radius R_1 . Assume there is friction between the shaft and the pulley with coefficient of friction μ , and friction angle ϕ defined by $\mu = \tan(\phi)$. Assume the two ends of the line that are wrapped around the pulley are parallel.

- What is the relation between the two tensions when the pulley is turning? You may assume that the bearing shaft touches the hole in the pulley at only one point. *

- b) Plug in some reasonable numbers for R_i , R_o and μ (or ϕ) to see one reason why wheels (say pulleys) are such a good idea even when the bearings are not all that well lubricated. *
- c) (optional) To further emphasize the point look at the relation between the two string tensions when the bearing is locked (frozen, welded) and the string slides on the pulley with same coefficient of friction μ (see, for example, Beer and Johnston Statics section 8.10). Look at the force ratios from parts (a) and (b) for a reasonable value of μ , say $\mu = 0.2$. *

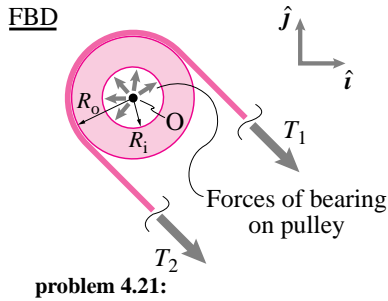

4.22 A massless triangular plate rests against a frictionless wall at point D and is rigidly attached to a massless rod supported by two ideal bearings fixed to the floor. A ball of mass m is fixed to the centroid of the plate. There is gravity and the system is at rest. What is the reaction at point D on the plate?

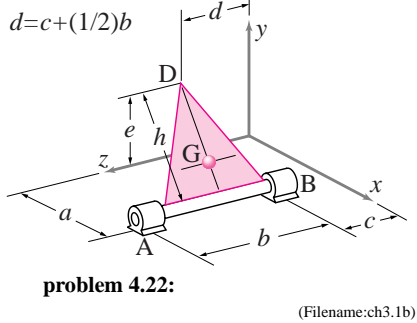

4.7 Hydrostatics

4.8 Advanced statics

4.23 See also problem 5.119. For the three cases (a), (b), and (c), below, find the tension in the string AB. In all cases the strings hold up the mass $m = 3$ kg. You may assume the local gravitational constant is $g = 10$ m/s². In all cases the winches are pulling in the string so that the velocity of the mass is a constant 4 m/s upwards (in the \hat{k} direction). [Note that in problems (b) and (c), in order to pull the mass up at constant rate the winches must pull in the strings at an unsteady speed.] *

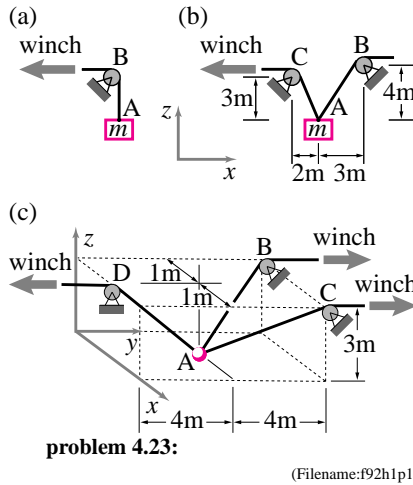

4.24 The strings hold up the mass $m = 3$ kg. You may assume the local gravitational constant is $g = 10$ m/s². Find the tensions in the strings if the mass is at rest.

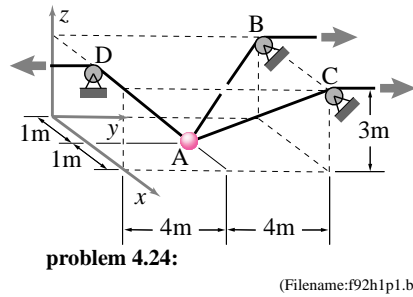

4.25 Hanging a shelf. A uniform 5 kg shelf is supported at one corner with a ball and socket joint and the other three corners with strings. At the moment of interest the shelf is at rest. Gravity acts in the $-\hat{k}$ direction. The shelf is in the xy plane.

- a) Draw a FBD of the shelf.
- b) Challenge: without doing any calculations on paper can you find one of the reaction force components or the tension in any of the cables? Give yourself a few minutes of staring to try to find this force. If you can't, then come back to this question after you have done all the calculations.
- c) Write down the equation of force equilibrium.
- d) Write down the moment balance equation using the center of mass as a reference point.
- e) By taking components, turn (b) and (c) into six scalar equations in six unknowns.
- f) Solve these equations by hand or on the computer.
- g) Instead of using a system of equations try to find a single equation which can be solved for T_{EH} . Solve it and compare to your result from before. *

h) Challenge: For how many of the reactions can you find one equation which will tell you that particular reaction without knowing any of the other reactions? [Hint, try moment balance about various axes as well as a force balance in an appropriate direction. It is possible to find five of the six unknown reaction components this way.] Must these solutions agree with (d)? Do they?

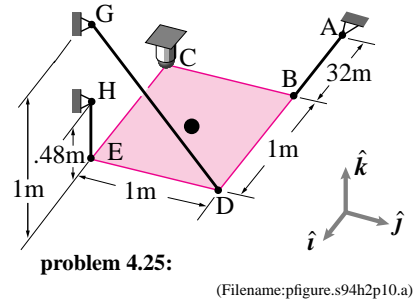

Problems for Chapter 5

Unconstrained motion of particles

5.1 Force and motion in 1D

5.1 In elementary physics, people say “ $F = ma$ ”. What is a more precise statement of an equation we use here that reduces to $F = ma$ for one-dimensional motion of a particle?

5.2 Does linear momentum depend on reference point? (Assume all candidate points are fixed in the same Newtonian reference frame.)

5.3 The distance between two points in a bicycle race is 10 km. How many minutes does a bicyclist take to cover this distance if he/she maintains a constant speed of 15 mph.

5.4 Given that $\dot{x} = k_1 + k_2t$, $k_1 = 1$ ft/s, $k_2 = 1$ ft/s², and $x(0) = 1$ ft, what is $x(10$ s)?

5.5 Find $x(3$ s) given that

$$\dot{x} = x/(1\text{ s}) \quad \text{and} \quad x(0) = 1\text{ m}$$

or, expressed slightly differently,

$$\dot{x} = cx \quad \text{and} \quad x(0) = x_0,$$

where $c = 1\text{ s}^{-1}$ and $x_0 = 1$ m. Make a sketch of x versus t . *

5.6 Given that $\dot{x} = A \sin[(3\text{ rad/s})t]$, $A = 0.5$ m/s, and $x(0) = 0$ m, what is $x(\pi/2$ s)?

5.7 Given that $\dot{x} = x/s$ and $x(0\text{ s}) = 1$ m, find $x(5$ s).

5.8 Let $a = \frac{dv}{dt} = -kv^2$ and $v(0) = v_0$. Find t such that $v(t) = \frac{1}{2}v_0$.

5.9 A sinusoidal force acts on a 1 kg mass as shown in the figure and graph below. The mass is initially still; i. e.,

$$x(0) = v(0) = 0.$$

- What is the velocity of the mass after 2π seconds?
- What is the position of the mass after 2π seconds?
- Plot position x versus time t for the motion.

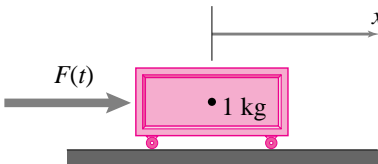
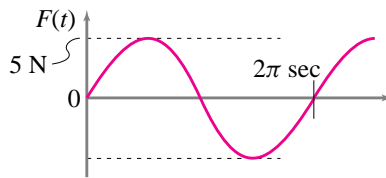

problem 5.9:

(Filename: pfigure.blue.6.1)

5.10 A motorcycle accelerates from 0 mph to 60 mph in 5 seconds. Find the average acceleration in m/s^2 . How does this acceleration compare with g , the acceleration of an object falling near the earth’s surface?

5.11 A particle moves along the x -axis with an initial velocity $v_x = 60$ m/s at the origin when $t = 0$. For the first 5 s it has no acceleration, and thereafter it is acted upon by a retarding force which gives it a constant acceleration $a_x = -10\text{ m/s}^2$. Calculate the velocity and the x -coordinate of the particle when $t = 8$ s and when $t = 12$ s, and find the maximum positive x coordinate reached by the particle.

5.12 The linear speed of a particle is given as $v = v_0 + at$, where v is in m/s, $v_0 = 20$ m/s, $a = 2\text{ m/s}^2$, and t is in seconds. Define appropriate dimensionless variables and write a dimensionless equation that describes the relation of v and t .

5.13 A ball of mass m has an acceleration $\vec{a} = cv^2\hat{i}$. Find the position of the ball as a function of velocity.

5.14 A ball of mass m is dropped from rest at a height h above the ground. Find the position and velocity as a function of time. Neglect air friction. When does the ball hit the ground? What is the velocity of the ball just before it hits?

5.15 A ball of mass m is dropped vertically from rest at a height h above the ground. Air resistance causes a drag force on the ball directly proportional to the speed v of the ball, $F_d = bv$. The drag force acts in a direction opposite to the direction of motion. Find the velocity and position of the ball as a function of time. Find the velocity as a function of position. Gravity is non-negligible, of course.

5.16 A grain of sugar falling through honey has a negative acceleration proportional to the difference between its velocity and its ‘terminal’

velocity (which is a known constant v_T). Write this sentence as a differential equation, defining any constants you need. Solve the equation assuming some given initial velocity v_0 . [hint: acceleration is the time-derivative of velocity]

5.17 The mass-dashpot system shown below is released from rest at $x = 0$. Determine an equation of motion for the particle of mass m that involves only \dot{x} and x (a first-order ordinary differential equation). The damping coefficient of the dashpot is c .

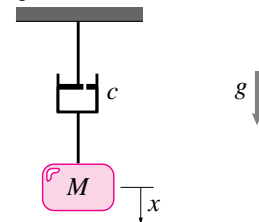

problem 5.17:

(Filename: pfigure.blue.151.2)

5.18 Due to gravity, a particle falls in air with a drag force proportional to the speed squared.

- Write $\sum \vec{F} = m\vec{a}$ in terms of variables you clearly define,
- find a constant speed motion that satisfies your differential equation,
- pick numerical values for your constants and for the initial height. Assume the initial speed is zero
 - set up the equation for numerical solution,
 - solve the equation on the computer,
 - make a plot with your computer solution and show how that plot supports your answer to (b).

5.19 A ball of mass m is dropped vertically from rest at a height h above the ground. Air resistance causes a drag force on the ball proportional to the speed of the ball squared, $F_d = cv^2$. The drag force acts in a direction opposite to the direction of motion. Find the velocity as a function of position.

5.20 A force pulls a particle of mass m towards the origin according to the law (assume same equation works for $x > 0$, $x < 0$)

$$F = Ax + Bx^2 + C\dot{x}$$

Assume $\dot{x}(0) = 0$.

Using numerical solution, find values of A , B , C , m , and x_0 so that

- the mass never crosses the origin,
- the mass crosses the origin once,
- the mass crosses the origin many times.

5.21 A car accelerates to the right with constant acceleration starting from a stop. There is wind resistance force proportional to the square of the speed of the car. Define all constants that you use.

- What is its position as a function of time?
- What is the total force (sum of all forces) on the car as a function of time?
- How much power P is required of the engine to accelerate the car in this manner (as a function of time)?

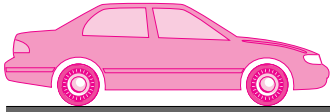

problem 5.21: Car.

(Filename:s97p1.2)

5.22 A ball of mass m is dropped vertically from a height h . The only force acting on the ball in its flight is gravity. The ball strikes the ground with speed v^- and after collision it rebounds vertically with reduced speed v^+ directly proportional to the incoming speed, $v^+ = ev^-$, where $0 < e < 1$. What is the maximum height the ball reaches after one bounce, in terms of h , e , and g . *

- Do this problem using linear momentum balance and setting up and solving the related differential equations and “jump” conditions at collision.
- Do this problem again using energy balance.

5.23 A ball is dropped from a height of $h_0 = 10$ m onto a hard surface. After the first bounce, it reaches a height of $h_1 = 6.4$ m. What is the vertical coefficient of restitution, assuming it is decoupled from tangential motion? What is the height of the second bounce, h_2 ?

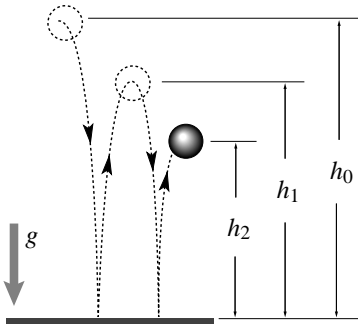

problem 5.23:

(Filename:Dane94s1q7)

5.24 In problem 5.23, show that the number of bounces goes to infinity in finite time, assuming that the vertical coefficient is fixed. Find the time in terms of the initial height h_0 , the coefficient of restitution, e , and the gravitational constant, g .

5.2 Energy methods in 1D

5.25 The power available to a very strong accelerating cyclist is about 1 horsepower. Assume a rider starts from rest and uses this constant power. Assume a mass (bike + rider) of 150 lbm, a realistic drag force of $.006 \text{ lbf}/(\text{ft}/\text{s})^2 v^2$. Neglect other drag forces.

- What is the peak speed of the cyclist?
- Using analytic or numerical methods make a plot of speed vs. time.
- What is the acceleration as $t \rightarrow \infty$ in this solution?
- What is the acceleration as $t \rightarrow 0$ in your solution?

5.26 Given $\dot{v} = -\frac{gR^2}{r^2}$, where g and R are constants and $v = \frac{dr}{dt}$. Solve for v as a function of r if $v(r = R) = v_0$. [Hint: Use the chain rule of differentiation to eliminate t , i.e., $\frac{dv}{dt} = \frac{dv}{dr} \cdot \frac{dr}{dt} = \frac{dv}{dr} \cdot v$. Or find a related dynamics problem and use conservation of energy.]

Also see several problems in the harmonic oscillator section.

5.3 The harmonic oscillator

The first set of problems are entirely about the harmonic oscillator governing differential equation, with no mechanics content or context.

5.27 Given that $\ddot{x} = -(1/\text{s}^2)x$, $x(0) = 1$ m, and $\dot{x}(0) = 0$ find:

- $x(\pi \text{ s}) = ?$
- $\dot{x}(\pi \text{ s}) = ?$

5.28 Given that $\ddot{x} + x = 0$, $x(0) = 1$, and $\dot{x}(0) = 0$, find the value of x at $t = \pi/2$ s.

5.29 Given that $\ddot{x} + \lambda^2 x = C_0$, $x(0) = x_0$, and $\dot{x}(0) = 0$, find the value of x at $t = \pi/\lambda$ s.

The next set of problems concern one mass connected to one or more springs and possibly with a constant force applied.

5.30 Consider a mass m on frictionless rollers. The mass is held in place by a spring with stiffness k and rest length ℓ . When the spring is relaxed the position of the mass is $x = 0$. At times $t = 0$ the mass is at $x = d$ and is let go with no velocity. The gravitational constant is g . In terms of the quantities above,

- What is the acceleration of the block at $t = 0^+$?
- What is the differential equation governing $x(t)$?
- What is the position of the mass at an arbitrary time t ?

d) What is the speed of the mass when it passes through $x = 0$?

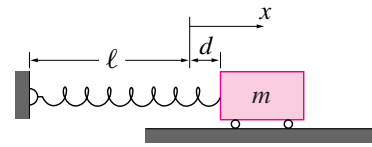

problem 5.30:

(Filename:pfigure.blue.25.1)

5.31 Spring and mass. A spring with rest length ℓ_0 is attached to a mass m which slides frictionlessly on a horizontal ground as shown. At time $t = 0$ the mass is released with no initial speed with the spring stretched a distance d . [Remember to define any coordinates or base vectors you use.]

- What is the acceleration of the mass just after release?
- Find a differential equation which describes the horizontal motion of the mass.
- What is the position of the mass at an arbitrary time t ?
- What is the speed of the mass when it passes through the position where the spring is relaxed?

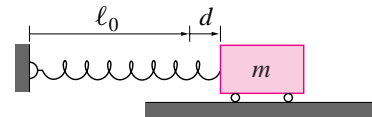

problem 5.31:

(Filename:s97f1)

5.32 Reconsider the spring-mass system in problem 3.20. Let $m = 2$ kg and $k = 5$ N/m. The mass is pulled to the right a distance $x = x_0 = 0.5$ m from the unstretched position and released from rest. At the instant of release, no external forces act on the mass other than the spring force and gravity.

- What is the initial potential and kinetic energy of the system?
- What is the potential and kinetic energy of the system as the mass passes through the static equilibrium (unstretched spring) position?

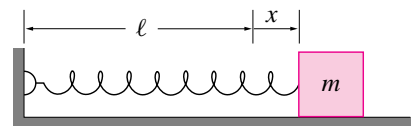

problem 5.32:

(Filename:ch2.10.a)

5.33 Reconsider the spring-mass system from problem 5.30.

- Find the potential and kinetic energy of the spring mass system as functions of time.

- b) Using the computer, make a plot of the potential and kinetic energy as a function of time for several periods of oscillation. Are the potential and kinetic energy ever equal at the same time? If so, at what position $x(t)$?
- c) Make a plot of kinetic energy versus potential energy. What is the phase relationship between the kinetic and potential energy?

5.34 For the three spring-mass systems shown in the figure, find the equation of motion of the mass in each case. All springs are massless and are shown in their relaxed states. Ignore gravity. (In problem (c) assume vertical motion.) *

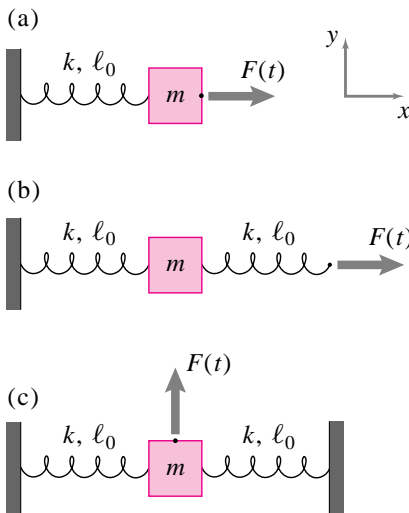

problem 5.34:

(Filename:summer95f.3)

5.35 A spring and mass system is shown in the figure.

- a) First, as a review, let $k_1, k_2,$ and k_3 equal zero and k_4 be nonzero. What is the natural frequency of this system?
- b) Now, let all the springs have non-zero stiffness. What is the stiffness of a single spring equivalent to the combination of k_1, k_2, k_3, k_4 ? What is the frequency of oscillation of mass M ?
- c) What is the equivalent stiffness, k_{eq} , of all of the springs together. That is, if you replace all of the springs with one spring, what would its stiffness have to be such that the system has the same natural frequency of vibration?

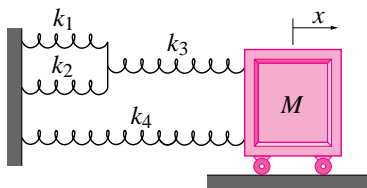

problem 5.35:

(Filename:pfigure.blue.159.3)

5.36 The mass shown in the figure oscillates in the vertical direction once set in motion by displacing it from its static equilibrium position. The position $y(t)$ of the mass is measured from the fixed support, taking downwards as positive. The static equilibrium position is y_s and the relaxed length of the spring is l_0 . At the instant shown, the position of the mass is y and its velocity \dot{y} , directed downwards. Draw a free body diagram of the mass at the instant of interest and evaluate the left hand side of the energy balance equation ($P = E_K$).

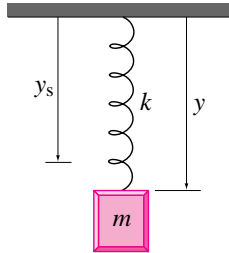

problem 5.36:

(Filename:pfig2.3.rp1)

5.37 Mass hanging from a spring. A mass m is hanging from a spring with constant k which has the length l_0 when it is relaxed (i. e., when no mass is attached). It only moves vertically.

- a) Draw a Free Body Diagram of the mass.
- b) Write the equation of linear momentum balance. *
- c) Reduce this equation to a standard differential equation in x , the position of the mass. *
- d) Verify that one solution is that $x(t)$ is constant at $x = l_0 + mg/k$.
- e) What is the meaning of that solution? (That is, describe in words what is going on.) *
- f) Define a new variable $\hat{x} = x - (l_0 + mg/k)$. Substitute $x = \hat{x} + (l_0 + mg/k)$ into your differential equation and note that the equation is simpler in terms of the variable \hat{x} . *
- g) Assume that the mass is released from an initial position of $x = D$. What is the motion of the mass? *
- h) What is the period of oscillation of this oscillating mass? *
- i) Why might this solution not make physical sense for a long, soft spring if $D > l_0 + 2mg/k$? *

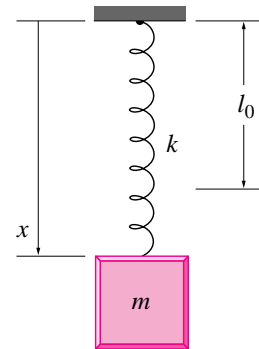

problem 5.37:

(Filename:pg141.1)

The following problem concerns simple harmonic motion for part of the motion. It involves pasting together solutions.

5.38 One of the winners in the egg-drop contest sponsored by a local chapter of ASME each spring, was a structure in which rubber bands held the egg at the center of it. In this problem, we will consider the simpler case of the egg to be a particle of mass m and the springs to be linear devices of spring constant k . We will also consider only a two-dimensional version of the winning design as shown in the figure. If the frame hits the ground on one of the straight sections, what will be the frequency of vibration of the egg after impact? [Assume small oscillations and that the springs are initially stretched.]

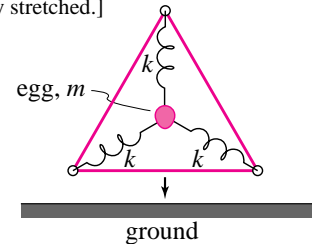

problem 5.38:

(Filename:pfigure.blue.149.1)

5.39 A person jumps on a trampoline. The trampoline is modeled as having an effective vertical undamped linear spring with stiffness $k = 200 \text{ lbf/ft}$. The person is modeled as a rigid mass $m = 150 \text{ lbm}$. $g = 32.2 \text{ ft/s}^2$.

- a) What is the period of motion if the person's motion is so small that her feet never leave the trampoline? *
- b) What is the maximum amplitude of motion for which her feet never leave the trampoline? *
- c) (harder) If she repeatedly jumps so that her feet clear the trampoline by a height $h = 5 \text{ ft}$, what is the period of this motion? *

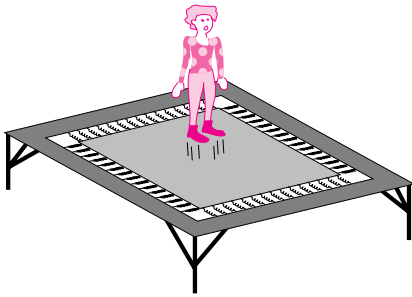

problem 5.39: A person jumps on a trampoline.

(Filename:pfigure3.trampoline)

5.4 More on vibrations: damping

5.40 If $\ddot{x} + c\dot{x} + kx = 0$, $x(0) = x_0$, and $\dot{x}(0) = 0$, find $x(t)$.

5.41 A mass moves on a frictionless surface. It is connected to a dashpot with damping coefficient b to its right and a spring with constant k and rest length ℓ to its left. At the instant of interest, the mass is moving to the right and the spring is stretched a distance x from its position where the spring is unstretched. There is gravity.

- a) Draw a free body diagram of the mass at the instant of interest.
- b) Evaluate the left hand side of the equation of linear momentum balance as explicitly as possible. *

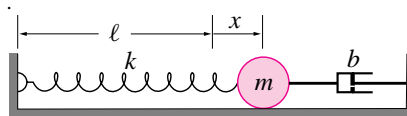

problem 5.41:

(Filename:ch2.11)

5.5 Forced oscillations and resonance

5.42 A 3 kg mass is suspended by a spring ($k = 10 \text{ N/m}$) and forced by a 5 N sinusoidally oscillating force with a period of 1 s. What is the amplitude of the steady-state oscillations (ignore the “homogeneous” solution)

5.43 Given that $\ddot{\theta} + k^2\theta = \beta \sin \omega t$, $\theta(0) = 0$, and $\dot{\theta}(0) = \dot{\theta}_0$, find $\theta(t)$.

5.44 A machine produces a steady-state vibration due to a forcing function described by $Q(t) = Q_0 \sin \omega t$, where $Q_0 = 5000 \text{ N}$. The machine rests on a circular concrete foundation. The foundation rests on an isotropic, elastic half-space. The equivalent spring constant of the half-space is $k = 2,000,000 \text{ N-m}$ and has a damping ratio $d = c/c_c = 0.125$. The machine operates at a frequency of $\omega = 4 \text{ Hz}$.

- (a) What is the natural frequency of the system?
- (b) If the system were undamped, what would the steady-state displacement be?
- (c) What is the steady-state displacement given that $d = 0.125$?
- (d) How much additional thickness of concrete should be added to the footing to reduce the damped steady-state amplitude by 50%? (The diameter must be held constant.)

5.6 Coupled motions in 1D

The primary emphasis of this section is setting up correct differential equations (without sign errors) and solving these equations on the computer. Experts note: normal modes are covered in the vibrations chapter. These first problems are just math problems, using some of the skills that are needed for the later problems.

5.45 Write the following set of coupled second order ODE’s as a system of first order ODE’s.

$$\begin{aligned} \ddot{x}_1 &= k_2(x_2 - x_1) - k_1x_1 \\ \ddot{x}_2 &= k_3x_2 - k_2(x_2 - x_1) \end{aligned}$$

5.46 See also problem 5.47. The solution of a set of a second order differential equations is:

$$\begin{aligned} \xi(t) &= A \sin \omega t + B \cos \omega t + \xi^* \\ \dot{\xi}(t) &= A\omega \cos \omega t - B\omega \sin \omega t, \end{aligned}$$

where A and B are constants to be determined from initial conditions. Assume A and B are the only unknowns and write the equations in matrix form to solve for A and B in terms of $\xi(0)$ and $\dot{\xi}(0)$.

5.47 Solve for the constants A and B in Problem 5.46 using the matrix form, if $\xi(0) = 0$, $\dot{\xi}(0) = 0.5$, $\omega = 0.5 \text{ rad/s}$ and $\xi^* = 0.2$.

5.48 A set of first order linear differential equations is given:

$$\begin{aligned} \dot{x}_1 &= x_2 \\ \dot{x}_2 + kx_1 + cx_2 &= 0 \end{aligned}$$

Write these equations in the form $\dot{\vec{x}} = [\mathbf{A}]\vec{x}$, where $\vec{x} = \begin{Bmatrix} x_1 \\ x_2 \end{Bmatrix}$.

5.49 Write the following pair of coupled ODE’s as a set of first order ODE’s.

$$\begin{aligned} \ddot{x}_1 + x_1 &= \dot{x}_2 \sin t \\ \ddot{x}_2 + x_2 &= \dot{x}_1 \cos t \end{aligned}$$

5.50 The following set of differential equations can not only be written in first order form but in matrix form $\dot{\vec{x}} = [\mathbf{A}]\vec{x} + \vec{c}$. In general things are not so simple, but this *linear* case is prevalent in the analytic study of dynamical systems.

$$\begin{aligned} \dot{x}_1 &= x_3 \\ \dot{x}_2 &= x_4 \\ \dot{x}_3 + 5\Omega^2x_1 - 4\Omega^2x_2 &= 2\Omega^2v_1^* \\ \dot{x}_4 - 4\Omega^2x_1 + 5\Omega^2x_2 &= -\Omega^2v_1^* \end{aligned}$$

5.51 Write each of the following equations as a system of first order ODE’s.

- a) $\ddot{\theta} + \lambda^2\theta = \cos t$,
- b) $\ddot{x} + 2p\dot{x} + kx = 0$,

c) $\ddot{x} + 2c\dot{x} + k \sin x = 0$.

5.52 A train is moving at constant absolute velocity $v\hat{i}$. A passenger, idealized as a point mass, is walking at an absolute velocity $u\hat{i}$, where $u > v$. What is the velocity of the passenger relative to the train?

• • •

5.53 Two equal masses, each denoted by the letter m , are on an air track. One mass is connected by a spring to the end of the track. The other mass is connected by a spring to the first mass. The two spring constants are equal and represented by the letter k . In the rest (springs are relaxed) configuration, the masses are a distance ℓ apart. Motion of the two masses x_1 and x_2 is measured relative to this configuration.

- Draw a free body diagram for each mass.
- Write the equation of linear momentum balance for each mass.
- Write the equations as a system of first order ODEs.
- Pick parameter values and initial conditions of your choice and simulate a motion of this system. Make a plot of the motion of, say, one of the masses vs time.
- Explain how your plot does or does not make sense in terms of your understanding of this system. Is the initial motion in the right direction? Are the solutions periodic? Bounded? etc.

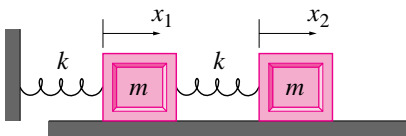

problem 5.53:

(Filename: pfigure.s94f1p4)

5.54 Two equal masses, each denoted by the letter m , are on an air track. One mass is connected by a spring to the end of the track. The other mass is connected by a spring to the first mass. The two spring constants are equal and represented by the letter k . In the rest configuration (springs are relaxed) the masses are a distance ℓ apart. Motion of the two masses x_1 and x_2 is measured relative to this configuration.

- Write the potential energy of the system for arbitrary displacements x_1 and x_2 at some time t .
- Write the kinetic energy of the system at the same time t in terms of \dot{x}_1, \dot{x}_2, m , and k .
- Write the total energy of the system.

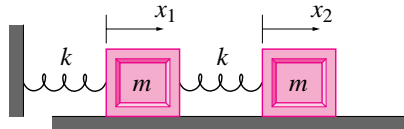

problem 5.54:

(Filename: pfigure.twomassenergy)

5.55 Normal Modes. Three equal springs (k) hold two equal masses (m) in place. There is no friction. x_1 and x_2 are the displacements of the masses from their equilibrium positions.

- How many independent normal modes of vibration are there for this system? *
- Assume the system is in a normal mode of vibration and it is observed that $x_1 = A \sin(ct) + B \cos(ct)$ where A, B , and c are constants. What is $x_2(t)$? (The answer is not unique. You may express your answer in terms of any of A, B, c, m and k .) *
- Find all of the frequencies of normal-mode-vibration for this system in terms of m and k . *

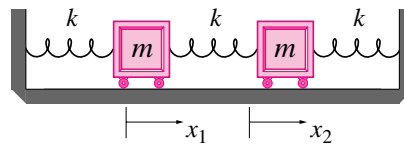

problem 5.55:

(Filename: pfigure.f93f2)

5.56 A two degree of freedom spring-mass system. A two degree of freedom mass-spring system, made up of two unequal masses m_1 and m_2 and three springs with unequal stiffnesses k_1, k_2 and k_3 , is shown in the figure. All three springs are relaxed in the configuration shown. Neglect friction.

- Derive the equations of motion for the two masses. *
- Does each mass undergo simple harmonic motion? *

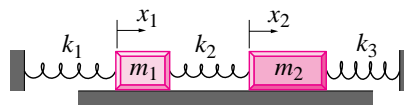

problem 5.56:

(Filename: pfigure.s94h5p1)

5.57 For the three-mass system shown, draw a free body diagram of each mass. Write the spring forces in terms of the displacements x_1, x_2 , and x_3 .

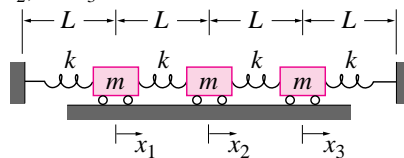

problem 5.57:

(Filename: s92f1p1)

5.58 The springs shown are relaxed when $x_A = x_B = x_D = 0$. In terms of some or all of $m_A, m_B, m_D, x_A, x_B, x_D, \dot{x}_A, \dot{x}_B, \dot{x}_C$, and k_1, k_2, k_3, k_4, c_1 , and F , find the acceleration of block B. *

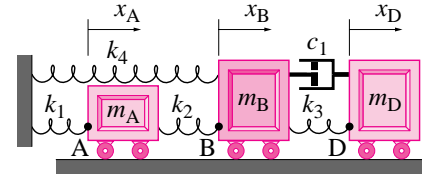

problem 5.58:

(Filename: pfigure.s95q3)

5.59 A system of three masses, four springs, and one damper are connected as shown. Assume that all the springs are relaxed when $x_A = x_B = x_D = 0$. Given $k_1, k_2, k_3, k_4, c_1, m_A, m_B, m_D, x_A, x_B, x_D, \dot{x}_A, \dot{x}_B$, and \dot{x}_D , find the acceleration of mass B, $\ddot{a}_B = \ddot{x}_B\hat{i}$. *

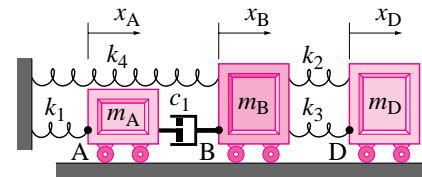

problem 5.59:

(Filename: pfigure.s95f1)

5.60 Equations of motion. Two masses are connected to fixed supports and each other with the three springs and dashpot shown. The force F acts on mass 2. The displacements x_1 and x_2 are defined so that $x_1 = x_2 = 0$ when the springs are unstretched. The ground is frictionless. The governing equations for the system shown can be written in first order form if we define $v_1 \equiv \dot{x}_1$ and $v_2 \equiv \dot{x}_2$.

- Write the governing equations in a neat first order form. Your equations should be in terms of any or all of the constants $m_1, m_2, k_1, k_2, k_3, C$, the constant force F , and t . Getting the signs right is important.
- Write computer commands to find and plot $v_1(t)$ for 10 units of time. Make up appropriate initial conditions.
- For constants and initial conditions of your choosing, plot x_1 vs t for enough time so that decaying erratic oscillations can be observed.

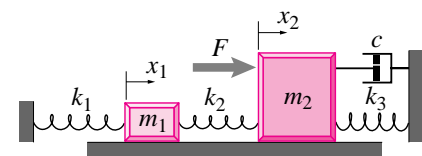

problem 5.60:

(Filename: p.f96.f.3)

5.61 $x_1(t)$ and $x_2(t)$ are measured positions on two points of a vibrating structure. $x_1(t)$ is shown. Some candidates for $x_2(t)$ are shown. Which of the $x_2(t)$ could possibly be associated with a normal mode vibration of the structure? Answer “could” or “could not” next to each

choice. (If a curve looks like it is meant to be a sine/cosine curve, it is.)

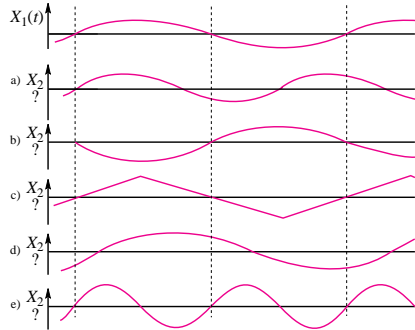

problem 5.61:

(Filename:pfigure.blue.144.1)

5.62 For the three-mass system shown, one of the normal modes is described with the eigenvector $(1, 0, -1)$. Assume $x_1 = x_2 = x_3 = 0$ when all the springs are fully relaxed.

- What is the angular frequency ω for this mode? Answer in terms of L, m, k , and g . (Hint: Note that in this mode of vibration the middle mass does not move.) *
- Make a neat plot of x_2 versus x_1 for one cycle of vibration with this mode.

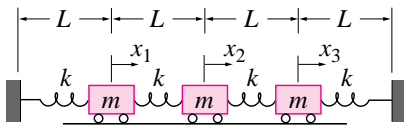

problem 5.62:

(Filename:pfigure.blue.160.2)

5.63 The three beads of masses $m, 2m$, and m connected by massless linear springs of constant k slide freely on a straight rod. Let x_i denote the displacement of the i^{th} bead from its equilibrium position at rest.

- Write expressions for the total kinetic and potential energies.
- Write an expression for the total linear momentum.
- Draw free body diagrams for the beads and use Newton's second law to derive the equations for motion for the system.
- Verify that total energy and linear momentum are both conserved.
- Show that the center of mass must either remain at rest or move at constant velocity.
- What can you say about vibratory (sinusoidal) motions of the system?

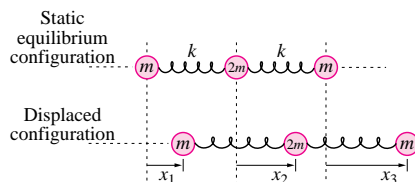

problem 5.63:

(Filename:pfigure.blue.161.1)

5.64 The system shown below comprises three identical beads of mass m that can slide frictionlessly on the rigid, immobile, circular hoop. The beads are connected by three identical linear springs of stiffness k , wound around the hoop as shown and equally spaced when the springs are unstretched (the strings are unstretched when $\theta_1 = \theta_2 = \theta_3 = 0$.)

- Determine the natural frequencies and associated mode shapes for the system. (Hint: you should be able to deduce a 'rigid-body' mode by inspection.)
- If your calculations in (a) are correct, then you should have also obtained the mode shape $(0, 1, -1)^T$. Write down the most general set of initial conditions so that the ensuing motion of the system is simple harmonic in that mode shape.
- Since $(0, 1, -1)^T$ is a mode shape, then by "symmetry", $(-1, 0, 1)^T$ and $(1, -1, 0)^T$ are also mode shapes (draw a picture). Explain how we can have three mode shapes associated with the same frequency.
- Without doing any calculations, compare the frequencies of the constrained system to those of the unconstrained system, obtained in (a).

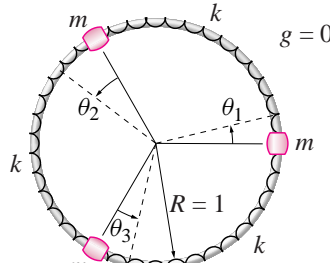

problem 5.64:

(Filename:pfigure.blue.158.1)

5.65 Equations of motion. Two masses are connected to fixed supports and each other with the two springs and dashpot shown. The displacements x_1 and x_2 are defined so that $x_1 = x_2 = 0$ when both springs are unstretched.

For the special case that $C = 0$ and $F_0 = 0$ clearly define two different set of initial conditions that lead to normal mode vibrations of this system.

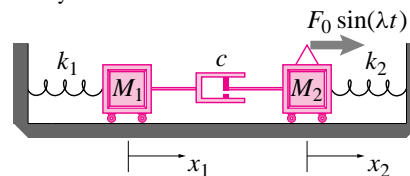

problem 5.65:

(Filename:p.s96.p3.1)

5.66 As in problem 5.59, a system of three masses, four springs, and one damper are connected as shown. Assume that all the springs are relaxed when $x_A = x_B = x_D = 0$.

- In the special case when $k_1 = k_2 = k_3 = k_4 = k$, $c_1 = 0$, and $m_A = m_B = m_D = m$, find a normal mode of vibration. Define it in any clear way and explain or show why it is a normal mode in any clear way. *
- In the same special case as in (a) above, find another normal mode of vibration. *

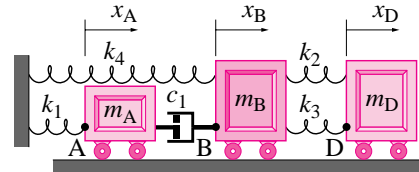

problem 5.66:

(Filename:pfigure.s95f1a)

5.67 As in problem 5.143, a system of three masses, four springs, and one damper are connected as shown. In the special case when $c_1 = 0$, find the normal modes of vibration.

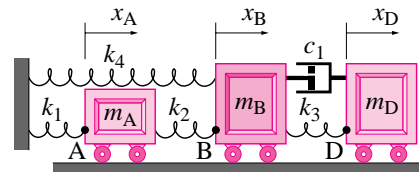

problem 5.67:

(Filename:pfigure.s95q3a)

5.68 Normal modes. All three masses have $m = 1$ kg and all 6 springs are $k = 1$ N/m. The system is at rest when $x_1 = x_2 = x_3 = 0$.

- Find as many different initial conditions as you can for which normal mode vibrations result. In each case, find the associated natural frequency. (we will call two initial conditions $[v]$ and $[w]$ different if there is no constant c so that $[v_1 v_2 v_3] = c[w_1 w_2 w_3]$. Assume the initial velocities are zero.)
- For the initial condition $[x_0] = [0.1 \text{ m } 0 \text{ } 0]$, $[\dot{x}_0] = [0 \text{ 2 m/s } 0]$ what is the initial (immediately after the start) acceleration of mass 2?

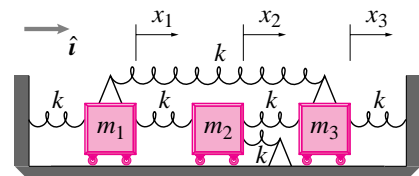

problem 5.68:

(Filename:pfigure3.f95p2p2)

5.7 Time derivative of a vector: position, velocity and acceleration

5.69 The position vector of a particle in the xy -plane is given as $\vec{r} = 3.0\text{ m}\hat{i} + 2.5\text{ m}\hat{j}$. Find (a) the distance of the particle from the origin and (b) a unit vector in the direction of \vec{r} .

5.70 Given $\vec{r}(t) = A \sin(\omega t)\hat{i} + Bt\hat{j} + C\hat{k}$, find

- $\vec{v}(t)$
- $\vec{a}(t)$
- $\vec{r}(t) \times \vec{a}(t)$.

5.71 A particle of mass $m = 3\text{ kg}$ travels in space with its position known as a function of time, $\vec{r} = (\sin \frac{t}{s})\text{ m}\hat{i} + (\cos \frac{t}{s})\text{ m}\hat{j} + te^{\frac{t}{s}}\text{ m/s}\hat{k}$. At $t = 3\text{ s}$, find the particle's

- velocity and
- acceleration.

5.72 A particle of mass $m = 2\text{ kg}$ travels in the xy -plane with its position known as a function of time, $\vec{r} = 3t^2\text{ m/s}^2\hat{i} + 4t^3\frac{\text{m}}{\text{s}^3}\hat{j}$. At $t = 5\text{ s}$, find the particle's

- velocity and *
- acceleration. *

5.73 If $\vec{r} = (u_0 \sin \Omega t)\hat{i} + v_0\hat{j}$ and $\vec{r}(0) = x_0\hat{i} + y_0\hat{j}$, with u_0 , v_0 , and Ω , find $\vec{r}(t) = x(t)\hat{i} + y(t)\hat{j}$. *

5.74 The velocity of a particle of mass m on a frictionless surface is given as $\vec{v} = (0.5\text{ m/s})\hat{i} - (1.5\text{ m/s})\hat{j}$. If the displacement is given by $\Delta\vec{r} = \vec{v}t$, find (a) the distance traveled by the mass in 2 seconds and (b) a unit vector along the displacement.

5.75 For $\vec{v} = v_x\hat{i} + v_y\hat{j} + v_z\hat{k}$ and $\vec{a} = 2\text{ m/s}^2\hat{i} - (3\text{ m/s}^2 - 1\text{ m/s}^3 t)\hat{j} - 5\text{ m/s}^4 t^2\hat{k}$, write the vector equation $\vec{v} = \int \vec{a} dt$ as three scalar equations.

5.76 Find $\vec{r}(5\text{ s})$ given that

$\vec{r} = v_1 \sin(ct)\hat{i} + v_2\hat{j}$ and $\vec{r}(0) = 2\text{ m}\hat{i} + 3\text{ m}\hat{j}$ and that v_1 is a constant 4 m/s , v_2 is a constant 5 m/s , and c is a constant 4 s^{-1} . Assume \hat{i} and \hat{j} are constant.

5.77 Let $\vec{r} = v_0 \cos \alpha \hat{i} + v_0 \sin \alpha \hat{j} + (v_0 \tan \theta - gt)\hat{k}$, where v_0 , α , θ , and g are constants. If $\vec{r}(0) = \vec{0}$, find $\vec{r}(t)$.

5.78 On a smooth circular helical path the velocity of a particle is $\vec{r} = -R \sin t \hat{i} + R \cos t \hat{j} + gt \hat{k}$. If $\vec{r}(0) = R\hat{i}$, find $\vec{r}(\pi/3\text{ s})$.

5.79 Draw unit vectors along $\vec{\omega} = (4.33\text{ rad/s})\hat{i} + (2.50\text{ rad/s})\hat{j}$ and $\vec{r} = (0.50\text{ ft})\hat{i} - (0.87\text{ ft})\hat{j}$ and find the angle between the two unit vectors.

5.80 What is the angle between the x -axis and the vector $\vec{v} = (0.3\hat{i} - 2.0\hat{j} + 2.2\hat{k})\text{ m/s}$?

5.81 The position of a particle is given by $\vec{r}(t) = (t^2\text{ m/s}^2)\hat{i} + e^{\frac{t}{s}}\text{ m}\hat{j}$. What are the velocity and acceleration of the particle? *

5.82 A particle travels on a path in the xy -plane given by $y(x) = \sin^2(\frac{x}{m})\text{ m}$, where $x(t) = t^3(\frac{\text{m}}{\text{s}^3})$. What are the velocity and acceleration of the particle in cartesian coordinates when $t = (\pi)^{\frac{1}{3}}\text{ s}$?

5.83 A particle travels on an elliptical path given by $y^2 = b^2(1 - \frac{x^2}{a^2})$ with constant speed v . Find the velocity of the particle when $x = a/2$ and $y > 0$ in terms of a , b , and v .

5.84 A particle travels on a path in the xy -plane given by $y(x) = (1 - e^{-\frac{x}{m}})\text{ m}$. Make a plot of the path. It is known that the x coordinate of the particle is given by $x(t) = t^2\text{ m/s}^2$. What is the rate of change of speed of the particle? What angle does the velocity vector make with the positive x axis when $t = 3\text{ s}$?

5.85 A particle starts at the origin in the xy -plane, ($x_0 = 0$, $y_0 = 0$) and travels only in the positive xy quadrant. Its speed and x coordinate are known to be $v(t) = \sqrt{1 + (\frac{4}{3})t^2}\text{ m/s}$ and $x(t) = t\text{ m/s}$, respectively. What is $\vec{r}(t)$ in cartesian coordinates? What are the velocity, acceleration, and rate of change of speed of the particle as functions of time? What kind of path is the particle on? What are the distance of the particle from the origin and its velocity and acceleration when $x = 3\text{ m}$?

5.8 Spatial dynamics of a particle

5.86 What symbols do we use for the following quantities? What are the definitions of these quantities? Which are vectors and which are scalars? What are the SI and US standard units for the following quantities?

- linear momentum
- rate of change of linear momentum
- angular momentum
- rate of change of angular momentum
- kinetic energy
- rate of change of kinetic energy
- moment
- work
- power

5.87 Does angular momentum depend on reference point? (Assume that all candidate points are fixed in the same Newtonian reference frame.)

5.88 Does kinetic energy depend on reference point? (Assume that all candidate points are fixed in the same Newtonian reference frame.)

5.89 What is the relation between the dynamics 'Linear Momentum Balance' equation and the statics 'Force Balance' equation?

5.90 What is the relation between the dynamics 'Angular Momentum Balance' equation and the statics 'Moment Balance' equation?

5.91 A ball of mass $m = 0.1\text{ kg}$ is thrown from a height of $h = 10\text{ m}$ above the ground with velocity $\vec{v} = 120\text{ km/h}\hat{i} - 120\text{ km/h}\hat{j}$. What is the kinetic energy of the ball at its release?

5.92 A ball of mass $m = 0.2\text{ kg}$ is thrown from a height of $h = 20\text{ m}$ above the ground with velocity $\vec{v} = 120\text{ km/h}\hat{i} - 120\text{ km/h}\hat{j} - 10\text{ km/h}\hat{k}$. What is the kinetic energy of the ball at its release?

5.93 How do you calculate P , the power of all external forces acting on a particle, from the forces \vec{F}_i and the velocity \vec{v} of the particle?

5.94 A particle A has velocity \vec{v}_A and mass m_A . A particle B has velocity $\vec{v}_B = 2\vec{v}_A$ and mass equal to the other $m_B = m_A$. What is the relationship between:

- \vec{L}_A and \vec{L}_B ,
- $\vec{H}_{A/C}$ and $\vec{H}_{B/C}$, and
- E_{KA} and E_{KB} ?

5.95 A bullet of mass 50 g travels with a velocity $\vec{v} = 0.8\text{ km/s}\hat{i} + 0.6\text{ km/s}\hat{j}$. (a) What is the linear momentum of the bullet? (Answer in consistent units.)

5.96 A particle has position $\vec{r} = 4\text{ m}\hat{i} + 7\text{ m}\hat{j}$, velocity $\vec{v} = 6\text{ m/s}\hat{i} - 3\text{ m/s}\hat{j}$, and acceleration $\vec{a} = -2\text{ m/s}^2\hat{i} + 9\text{ m/s}^2\hat{j}$. For each position of a point P defined below, find \vec{H}_P , the angular momentum of the particle with respect to the point P .

- $\vec{r}_P = 4\text{ m}\hat{i} + 7\text{ m}\hat{j}$,
- $\vec{r}_P = -2\text{ m}\hat{i} + 7\text{ m}\hat{j}$, and
- $\vec{r}_P = 0\text{ m}\hat{i} + 7\text{ m}\hat{j}$,
- $\vec{r}_P = \vec{0}$

5.97 The position vector of a particle of mass 1 kg at an instant t is $\vec{r} = 2\text{ m}\hat{i} - 0.5\text{ m}\hat{j}$. If the velocity of the particle at this instant is $\vec{v} = -4\text{ m/s}\hat{i} + 3\text{ m/s}\hat{j}$, compute (a) the linear momentum $\vec{L} = m\vec{v}$ and (b) the angular momentum ($\vec{H}_O = \vec{r}_O \times (m\vec{v})$).

5.98 The position of a particle of mass $m = 0.5\text{ kg}$ is $\vec{r}(t) = \ell \sin(\omega t)\hat{i} + h\hat{j}$; where $\omega = 2\text{ rad/s}$, $h = 2\text{ m}$, $\ell = 2\text{ m}$, and \vec{r} is measured from the origin.

- a) Find the kinetic energy of the particle at $t = 0$ s and $t = 5$ s.
- b) Find the rate of change of kinetic energy at $t = 0$ s and $t = 5$ s.

5.99 For a particle

$$E_K = \frac{1}{2} m v^2.$$

Why does it follow that $\dot{E}_K = m \vec{v} \cdot \vec{a}$? [hint: write v^2 as $\vec{v} \cdot \vec{v}$ and then use the product rule of differentiation.]

5.100 Consider a projectile of mass m at some instant in time t during its flight. Let \vec{v} be the velocity of the projectile at this instant (see the figure). In addition to the force of gravity, a drag force acts on the projectile. The drag force is proportional to the square of the speed (speed $\equiv |\vec{v}| = v$) and acts in the opposite direction. Find an expression for the net power of these forces ($P = \sum \vec{F} \cdot \vec{v}$) on the particle.

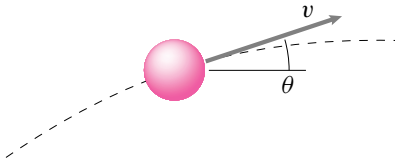

problem 5.100:

(Filename:pfig2.3.rp3)

5.101 A 10 gm wad of paper is tossed in the air (in a strong turbulent wind). The position, velocity, and acceleration of its center of mass are $\vec{r} = 3 m\hat{i} + 3 m\hat{j} + 6 m\hat{k}$, $\vec{v} = -9 m/s\hat{i} + 24 m/s\hat{j} + 30 m/s\hat{k}$, and $\vec{a} = -10 m/s^2\hat{i} + 24 m/s^2\hat{j} + 32 m/s^2\hat{k}$, respectively. Find the linear momentum \vec{L} and its rate of change $\dot{\vec{L}}$ of the potato's center of mass.

5.102 A 10 gm wad of paper is tossed into the air. At a particular instant of interest, the position, velocity, and acceleration of its center of mass are $\vec{r} = 3 m\hat{i} + 3 m\hat{j} + 6 m\hat{k}$, $\vec{v} = -9 m/s\hat{i} + 24 m/s\hat{j} + 30 m/s\hat{k}$, and $\vec{a} = -10 m/s^2\hat{i} + 24 m/s^2\hat{j} + 32 m/s^2\hat{k}$, respectively. What is the translational kinetic energy of the wad at the instant of interest?

5.103 A 2 kg particle moves so that its position \vec{r} is given by

$$\vec{r}(t) = [5 \sin(at)\hat{i} + bt^2\hat{j} + ct\hat{k}] \text{ m}$$

where $a = \pi/\text{sec}$, $b = .25/\text{sec}^2$, $c = 2/\text{sec}$.

- a) What is the linear momentum of the particle at $t = 1$ sec?
- b) What is the force acting on the particle at $t = 1$ sec?

5.104 A particle A has mass m_A and velocity \vec{v}_A . A particle B at the same location has mass $m_B = 2 m_A$ and velocity equal to the other $\vec{v}_B = \vec{v}_A$. Point C is a reference point. What is the relationship between:

- a) \vec{L}_A and \vec{L}_B ,
- b) $\vec{H}_{A/C}$ and $\vec{H}_{B/C}$, and
- c) E_{KA} and E_{KB} ?

5.105 A particle of mass $m = 3$ kg moves in space. Its position, velocity, and acceleration at a particular instant in time are $\vec{r} = 2 m\hat{i} + 3 m\hat{j} + 5 m\hat{k}$, $\vec{v} = -3 m/s\hat{i} + 8 m/s\hat{j} + 10 m/s\hat{k}$, and $\vec{a} = -5 m/s^2\hat{i} + 12 m/s^2\hat{j} + 16 m/s^2\hat{k}$, respectively. For this particle at the instant of interest, find its:

- a) linear momentum \vec{L} ,
- b) rate of change of linear momentum $\dot{\vec{L}}$,
- c) angular momentum about the origin \vec{H}_O ,
- d) rate of change of angular momentum about the origin $\dot{\vec{H}}_O$,
- e) kinetic energy E_K , and
- f) rate of change of kinetic energy \dot{E}_K .

5.106 A particle has position $\vec{r} = 3 m\hat{i} - 2 m\hat{j} + 4 m\hat{k}$, velocity $\vec{v} = 2 m/s\hat{i} - 3 m/s\hat{j} + 7 m/s\hat{k}$, and acceleration $\vec{a} = 1 m/s^2\hat{i} - 8 m/s^2\hat{j} + 3 m/s^2\hat{k}$. For each position of a point P defined below, find the rate of change of angular momentum of the particle with respect to the point P , $\dot{\vec{H}}_P$.

- a) $\vec{r}_P = 3 m\hat{i} - 2 m\hat{j} + 4 m\hat{k}$,
- b) $\vec{r}_P = 6 m\hat{i} - 4 m\hat{j} + 8 m\hat{k}$,
- c) $\vec{r}_P = -9 m\hat{i} + 6 m\hat{j} - 12 m\hat{k}$, and
- d) $\vec{r}_P = \vec{0}$

5.107 A particle of mass $m = 5$ kg has position, velocity, and acceleration $\vec{r} = 2 m\hat{j}$, $\vec{v} = 3 m/s\hat{i}$, and $\vec{a} = -7 m/s^2\hat{i}$, respectively, at a particular instant of interest. At the instant of interest find its:

- a) linear momentum \vec{L} ,
- b) rate of change of linear momentum $\dot{\vec{L}}$,
- c) angular momentum about the origin \vec{H}_O ,
- d) rate of change of angular momentum about the origin $\dot{\vec{H}}_O$,
- e) kinetic energy E_K , and
- f) rate of change of kinetic energy \dot{E}_K .
- g) the net force $\sum \vec{F}$ on the particle,
- h) the net moment on the particle about the origin $\sum \vec{M}_O$ due to the applied forces, and
- i) rate of change of work $\dot{W} = P$ done on the particle by the applied forces.

Particle FBD

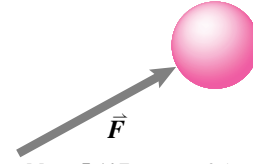

problem 5.107: FBD of the particle

(Filename:pfigure1.1.part.fbd)

5.108 A particle of mass $m = 6$ kg is moving in space. Its position, velocity, and acceleration at a particular instant in time are $\vec{r} = 1 m\hat{i} - 2 m\hat{j} + 4 m\hat{k}$, $\vec{v} = 3 m/s\hat{i} + 4 m/s\hat{j} - 7 m/s\hat{k}$, and $\vec{a} = 5 m/s^2\hat{i} + 11 m/s^2\hat{j} - 9 m/s^2\hat{k}$, respectively. For this particle at the instant of interest, find its:

- a) the net force $\sum \vec{F}$ on the particle,
- b) the net moment on the particle about the origin $\sum \vec{M}_O$ due to the applied forces, and
- c) the power P of the applied forces.

Particle FBD

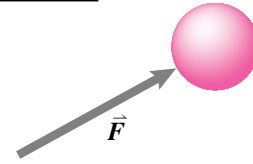

problem 5.108: FBD of the particle

(Filename:pfigure1.1.1.part.fbdb)

5.109 A particle of mass $m = 3$ kg is moving in the xz -plane. Its position, velocity, and acceleration at a particular instant of interest are $\vec{r} = 4 m\hat{i} + 2 m\hat{k}$, $\vec{v} = 3 m/s\hat{i} - 7 m/s\hat{k}$, and $\vec{a} = 3 m/s^2\hat{i} - 4 m/s^2\hat{k}$, respectively. For this particle at the instant of interest, find:

- a) the net force $\sum \vec{F}$ on the particle,
- b) the net moment on the particle about the origin $\sum \vec{M}_O$ due to the applied forces, and
- c) rate of change of work $\dot{W} = P$ done on the particle by the applied forces.

Particle FBD

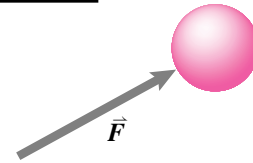

problem 5.109: FBD of the particle

(Filename:pfigure1.1.part.fbda)

5.110 A particle of mass $m = 3$ kg is moving in the xy -plane. Its position, velocity, and acceleration at a particular instant of interest are $\vec{r} = 2 m\hat{i} + 3 m\hat{j}$, $\vec{v} = -3 m/s\hat{i} + 8 m/s\hat{j}$, and $\vec{a} = -5 m/s^2\hat{i} + 12 m/s^2\hat{j}$, respectively. For this particle at the instant of interest, find its:

- a) linear momentum \vec{L} ,

- b) rate of change of linear momentum $\dot{\vec{L}}$,
 c) angular momentum about the origin \vec{H}_O ,
 d) rate of change of angular momentum about the origin $\dot{\vec{H}}_O$,
 e) kinetic energy E_K , and
 f) rate of change of kinetic energy \dot{E}_K .

5.111 At a particular instant of interest, a particle of mass $m_1 = 5$ kg has position, velocity, and acceleration $\vec{r}_1 = 3\text{ m}\hat{i}$, $\vec{v}_1 = -4\text{ m/s}\hat{j}$, and $\vec{a}_1 = 6\text{ m/s}^2\hat{j}$, respectively, and a particle of mass $m_2 = 5$ kg has position, velocity, and acceleration $\vec{r}_2 = -6\text{ m}\hat{i}$, $\vec{v}_2 = 5\text{ m/s}\hat{j}$, and $\vec{a}_2 = -4\text{ m/s}^2\hat{j}$, respectively. For the system of particles, find its

- a) linear momentum \vec{L} ,
 b) rate of change of linear momentum $\dot{\vec{L}}$
 c) angular momentum about the origin \vec{H}_O ,
 d) rate of change of angular momentum about the origin $\dot{\vec{H}}_O$,
 e) kinetic energy E_K , and
 f) rate of change of kinetic energy \dot{E}_K .

5.112 A particle of mass $m = 250$ gm is shot straight up (parallel to the y -axis) from the x -axis at a distance $d = 2$ m from the origin. The velocity of the particle is given by $\vec{v} = v\hat{j}$ where $v^2 = v_0^2 - 2ah$, $v_0 = 100\text{ m/s}$, $a = 10\text{ m/s}^2$ and h is the height of the particle from the x -axis.

- a) Find the linear momentum of the particle at the outset of motion ($h = 0$).
 b) Find the angular momentum of the particle about the origin at the outset of motion ($h = 0$).
 c) Find the linear momentum of the particle when the particle is 20 m above the x -axis.
 d) Find the angular momentum of the particle about the origin when the particle is 20 m above the x -axis.

5.113 For a particle, $\sum \vec{F} = m\vec{a}$. Two forces \vec{F}_1 and \vec{F}_2 act on a mass P as shown in the figure. P has mass 2 lbm. The acceleration of the mass is somehow measured to be $\vec{a} = -2\text{ ft/s}^2\hat{i} + 5\text{ ft/s}^2\hat{j}$.

- a) Write the equation

$$\sum \vec{F} = m\vec{a}$$

in vector form (evaluating each side as much as possible).

- b) Write the equation in scalar form (use any method you like to get two scalar equations in the two unknowns F_1 and F_2).
 c) Write the equation in matrix form.

d) Find $F_1 = |\vec{F}_1|$ and $F_2 = |\vec{F}_2|$ by the following methods:

- (a) from the scalar equations using hand algebra,
 (b) from the matrix equation using a computer, and
 (c) from the vector equation using a cross product.

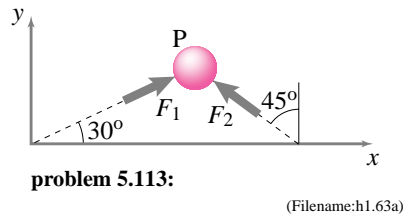

5.114 Three forces, $\vec{F}_1 = 20\text{ N}\hat{i} - 5\text{ N}\hat{j}$, $\vec{F}_2 = F_{2x}\hat{i} + F_{2z}\hat{k}$, and $\vec{F}_3 = F_3\hat{\lambda}$, where $\hat{\lambda} = \frac{1}{2}\hat{i} + \frac{\sqrt{3}}{2}\hat{j}$, act on a body with mass 2 kg. The acceleration of the body is $\vec{a} = -0.2\text{ m/s}^2\hat{i} + 2.2\text{ m/s}^2\hat{j} + 1.7\text{ m/s}^2\hat{k}$. Write the equation $\sum \vec{F} = m\vec{a}$ as scalar equations and solve them (most conveniently on a computer) for F_{2x} , F_{2z} , and F_3 .

5.115 The rate of change of linear momentum of a particle is known in two directions: $\dot{L}_x = 20\text{ kg m/s}^2$, $\dot{L}_y = -18\text{ kg m/s}^2$ and unknown in the z direction. The forces acting on the particle are $\vec{F}_1 = 25\text{ N}\hat{i} + 32\text{ N}\hat{j} + 75\text{ N}\hat{k}$, $\vec{F}_2 = F_{2x}\hat{i} + F_{2y}\hat{j}$ and $\vec{F}_3 = -F_3\hat{k}$.

Using $\sum \vec{F} = \dot{\vec{L}}$, separate the vector equation into scalar equations in the x , y , and z directions. Solve these equations (maybe with the help of a computer) to find F_{2x} , F_{2y} , and F_3 .

5.116 A block of mass 100 kg is pulled by two strings AC and BC. Given that the tensions $T_1 = 1200\text{ N}$ and $T_2 = 1500\text{ N}$, neglecting gravity, find the magnitude and direction of the acceleration of the block. [$\sum \vec{F} = m\vec{a}$]

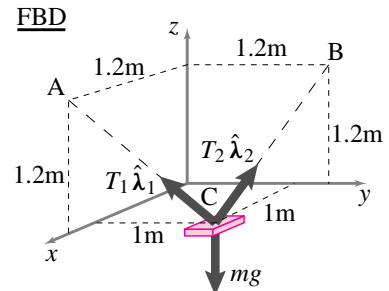
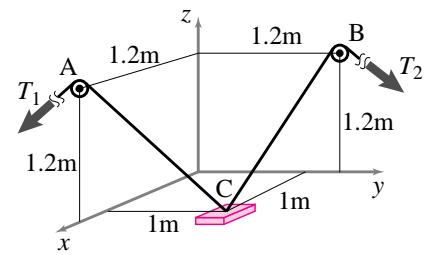

5.117 Neglecting gravity, the only force acting on the mass shown in the figure is from the string. Find the acceleration of the mass. Use the dimensions and quantities given. Recall that lbf is a pound force, lbm is a pound mass, and $\text{lbf}/\text{lbm} = g$. Use $g = 32\text{ ft/s}^2$. Note also that $3^2 + 4^2 + 12^2 = 13^2$.

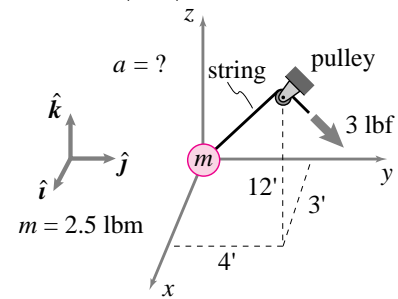

problem 5.117:

(Filename:pfigure.blue.4.1)

5.118 Three strings are tied to the mass shown with the directions indicated in the figure. They have unknown tensions T_1 , T_2 , and T_3 . There is no gravity. The acceleration of the mass is given as $\vec{a} = (-0.5\hat{i} + 2.5\hat{j} + \frac{1}{3}\hat{k})\text{ m/s}^2$.

- a) Given the free body diagram in the figure, write the equations of linear momentum balance for the mass.
 b) Find the tension T_3 . *

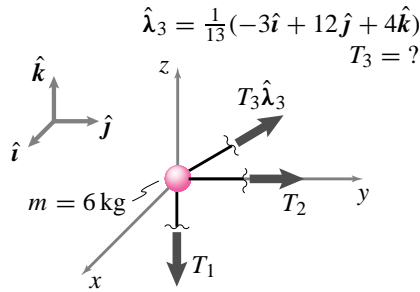

$$\vec{a} = (-.5\hat{i} + 2.5\hat{j} + \frac{1}{3}\hat{k}) \frac{m}{s^2}$$

problem 5.118:

(Filename:pfigure.blue.1.2)

5.119 For part(c) of problem 4.23, assume now that the mass at A has non-zero acceleration of $(1m/s^2)\hat{i} + (2m/s^2)\hat{j} + (3m/s^2)\hat{k}$. Find the tension in the three ropes at the instant shown.

5.120 A small object (mass = 2 kg) is being pulled by three strings as shown. The acceleration of the object at the position shown is $\vec{a} = (-0.6\hat{i} - 0.2\hat{j} + 2.0\hat{k}) m/s^2$.

- Draw a free body diagram of the mass.
- Write the equation of linear momentum balance for the mass. Use λ 's as unit vectors along the strings.
- Find the three tensions T_1 , T_2 , and T_3 at the instant shown. You may find these tensions by using hand algebra with the scalar equations, using a computer with the matrix equation, or by using a cross product on the vector equation.

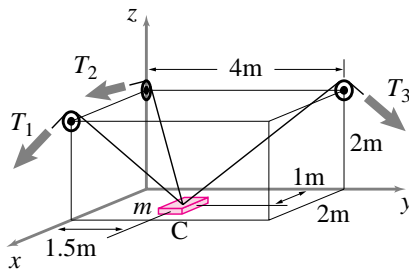

problem 5.120:

(Filename:pfigure.s94h2p9)

5.121 Use a computer to draw a square with corners at (1, 0), (0, -1), (-1, 0), (0, 1). This must be done with scientific software and not with a purely graphics program.

5.122 Draw a Circle on the Computer. We will be interested in keeping track of the motions of systems. A simple example is that of a particle going in circles at a constant rate. One can draw a circle quite well with a compass or with simple drawing programs. *But*, more complicated motions will be more difficult. Draw a circle on the computer and label the drawing (using computer generated lettering) with your name and the date.

a) You can program the circular shape any way that you think is fun (or any other way if you don't feel like having a good time). Your circle should be round. Measure its length and width with a ruler, they should be within 10% of each other (mark the dimensions by hand on your drawing).

b) A good solution will clearly document and explain the computer methodology.

5.123 What curve is defined by $x = \cos(t)^2$ and $y = \sin(t) * \cos(t)$ for $0 \leq t \leq \pi$? Try to figure it out without a computer. Make a computer plot.

5.124 Particle moves on a strange path. Given that a particle moves in the xy plane for 1.77 s obeying

$$\vec{r} = (5 \text{ m}) \cos^2(t^2/s^2)\hat{i} + (5 \text{ m}) \sin(t^2/s^2) \cos(t^2/s^2)\hat{j}$$

where x and y are the horizontal distance in meters and t is measured in seconds.

- Accurately plot the trajectory of the particle.
- Mark on your plot where the particle is going fast and where it is going slow. Explain how you know these points are the fast and slow places.

5.125 COMPUTER QUESTION: What's the plot? What's the mechanics question? Shown are shown some pseudo computer commands that are not commented adequately, unfortunately, and no computer is available at the moment.

- Draw as accurately as you can, assigning numbers etc, the plot that results from running these commands.
- See if you can guess a mechanical situation that is described by this program. Sketch the system and define the variables to make the script file agree with the problem stated.

$$\text{ODEs} = \{z1\dot{=} z2, z2\dot{=} 0\}$$

$$\text{ICs} = \{z1 = 1, z2 = 1\}$$

Solve ODEs with ICs from $t=0$ to $t=5$

plot $z2$ and $z1$ vs t on the same plot

problem 5.125:

(Filename:pfigure.s94f1p3)

Here begins a series of problems concerning the motion of particles over non-infinitesimal time.

5.126 A particle is blown out through the uniform spiral tube shown, which lies flat on a horizontal frictionless table. Draw the particle's path after it is expelled from the tube. Defend your answer.

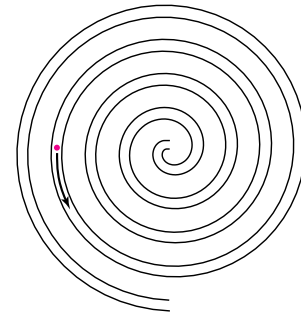

problem 5.126:

(Filename:pfigure.blue.29.1)

5.127 A ball going to the left with speed v_0 bounces against a frictionless rigid ramp which is sloped at an angle θ from the horizontal. The collision is completely elastic (the coefficient of restitution $e = 1$). Neglect gravity.

- Find the velocity of the ball after the collision. You may express your answer in terms of any combination of m , θ , v_0 , \hat{i} , \hat{j} , \hat{n} , and $\hat{\lambda}$.

$$\hat{n} = \sin\theta\hat{i} + \cos\theta\hat{j}$$

$$\hat{\lambda} = -\cos\theta\hat{i} + \sin\theta\hat{j}$$

$$\hat{i} = \sin\theta\hat{n} - \cos\theta\hat{\lambda}$$

$$\hat{j} = \cos\theta\hat{n} + \sin\theta\hat{\lambda}$$

- For what value of θ would the vertical component of the speed be maximized?

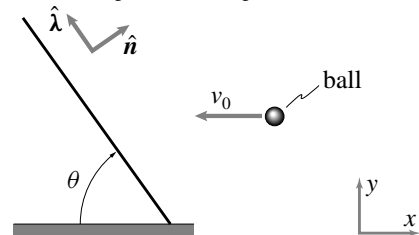

problem 5.127:

(Filename:ballramp)

5.128 Bungee Jumping. In a new safer bungee jumping system, people jump up from the ground while suspended from a rope that runs over a pulley at O and is connected to a stretched spring anchored at B. The pulley has negligible size, mass, and friction. For the situation shown the spring AB has rest length $\ell_0 = 2 \text{ m}$ and a stiffness of $k = 200 \text{ N/m}$. The inextensible massless rope from A to P has length $\ell_r = 8 \text{ m}$, the person has a mass of 100 kg. Take O to be the origin of an xy coordinate system aligned with the unit vectors \hat{i} and \hat{j}

- Assume you are given the position of the person $\vec{r} = x\hat{i} + y\hat{j}$ and the velocity of the person $\vec{v} = \dot{x}\hat{i} + \dot{y}\hat{j}$. Find her acceleration in terms of some or all of her position, her velocity, and the other parameters given. Use the numbers given, where supplied, in your final answer.

- b) Given that bungee jumper's initial position and velocity are $\mathbf{r}_0 = 1 \text{ m} \hat{i} - 5 \text{ m} \hat{j}$ and $\mathbf{v}_0 = \mathbf{0}$ write MATLAB commands to find her position at $t = \pi/\sqrt{2} \text{ s}$.
- c) Find the answer to part (b) with pencil and paper (a final numerical answer is desired).

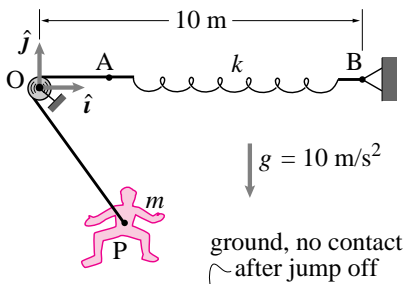

problem 5.128:

(Filename:s97p1.3)

5.129 A softball pitcher releases a ball of mass m upwards from her hand with speed v_0 and angle θ_0 from the horizontal. The only external force acting on the ball after its release is gravity.

- a) What is the equation of motion for the ball after its release?
- b) What are the position, velocity, and acceleration of the ball?
- c) What is its maximum height?
- d) At what distance does the ball return to the elevation of release?
- e) What kind of path does the ball follow and what is its equation y as a function of x ?

5.130 Find the trajectory of a not-vertically-fired cannon ball assuming the air drag is proportional to the speed. Assume the mass is 10 kg, $g = 10 \text{ m/s}$, the drag proportionality constant is $C = 5 \text{ N/(m/s)}$. The cannon ball is launched at 100 m/s at a 45 degree angle.

- Draw a free body diagram of the mass.
- Write linear momentum balance in vector form.
- Solve the equations on the computer and plot the trajectory.
- Solve the equations by hand and then use the computer to plot your solution.

5.131 See also problem 5.132. A baseball pitching machine releases a baseball of mass m from its barrel with speed v_0 and angle θ_0 from the horizontal. The only external forces acting on the ball after its release are gravity and air resistance. The speed of the ball is given by $v^2 = \dot{x}^2 + \dot{y}^2$. Taking into account air resistance on the ball proportional to its speed squared, $\mathbf{F}_d = -bv^2 \hat{e}_t$, find the equation of motion for the ball, after its release, in cartesian coordinates. *

5.132 The equations of motion from problem 5.131 are nonlinear and cannot be solved in closed form for the position of the baseball. Instead, solve the equations numerically. Make a computer simulation of the flight of the baseball, as follows.

- a) Convert the equation of motion into a system of first order differential equations. *
- b) Pick values for the gravitational constant g , the coefficient of resistance b , and initial speed v_0 , solve for the x and y coordinates of the ball and make a plots its trajectory for various initial angles θ_0 .
- c) Use Euler's, Runge-Kutta, or other suitable method to numerically integrate the system of equations.
- d) Use your simulation to find the initial angle that maximizes the distance of travel for ball, with and without air resistance.
- e) If the air resistance is very high, what is a qualitative description for the curve described by the path of the ball?

5.133 In the arcade game shown, the object of the game is to propel the small ball from the ejector device at O in such a way that it passes through the small aperture at A and strikes the contact point at B . The player controls the angle θ at which the ball is ejected and the initial velocity v_0 . The trajectory is confined to the frictionless xy -plane, which may or may not be vertical. Find the value of θ that gives success. The coordinates of A and B are $(2\ell, 2\ell)$ and $(3\ell, \ell)$, respectively, where ℓ is your favorite length unit.

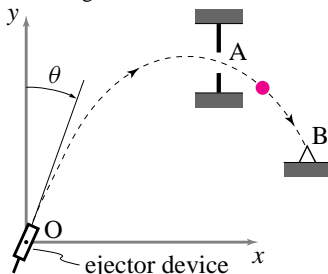

problem 5.133:

(Filename:pfigure.blue.32.1)

5.9 Central force motion and celestial mechanics

Experts note that none of these problems use polar or other fancy coordinates. Such descriptions come later in the text. At this point we want to lay out the basic equations and the qualitative features that can be found by numerical integration of the equations.

5.134 Under what circumstances is the angular momentum of a system, calculated relative to a point C which is fixed in a Newtonian frame, conserved?

5.135 A satellite is put into an elliptical orbit around the earth (that is, you can assume the orbit is closed) and has a velocity \vec{v}_P at position P . Find an expression for the velocity \vec{v}_A at position A . The radii to A and P are, respectively, r_A and r_P . [Hint: both total energy and angular momentum are conserved.]

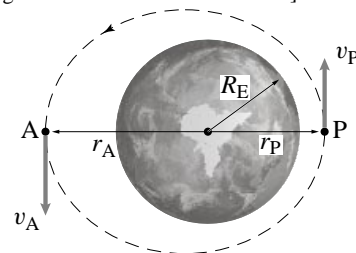

problem 5.135:

(Filename:pfigure.blue.64.2)

5.136 The mechanics of nuclear war. A missile, modelled as a point, is launched on a ballistic trajectory from the surface of the earth. The force on the missile from the earth's gravity is $F = mgR^2/r^2$ and is directed towards the center of the earth. When it is launched from the equator it has speed v_0 and in the direction shown, 45° from horizontal. For the purposes of this calculation ignore the earth's rotation. That is, you can think of this problem as two-dimensional in the plane shown. If you need numbers, use the following values:

- $m = 1000 \text{ kg}$ is the mass of the missile,
- $g = 10 \text{ m/s}^2$ is earth's gravitational constant at the earth's surface,
- $R = 6,400,000 \text{ m}$ is the radius of the earth, and
- $v_0 = 9000 \text{ m/s}$

$r(t)$ is the distance of the missile from the center of the earth.

- a) Draw a free body diagram of the missile. Write the linear momentum balance equation. Break this equation into x and y components. Rewrite these equations as a system of 4 first order ODE's suitable for computer solution. Write appropriate initial conditions for the ODE's.

- b) Using the computer (or any other means) plot the trajectory of the rocket after it is launched for a time of 6670 seconds. [Use a much shorter time when debugging your program.] On the same plot draw a (round) circle for the earth.

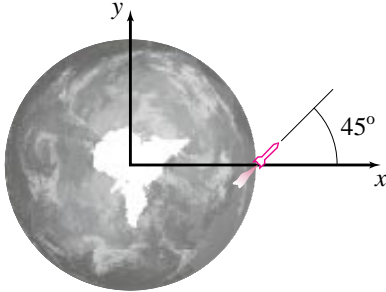

problem 5.136:

(Filename: pfigure.s94q12p1)

5.137 A particle of mass 2 kg moves in the horizontal xy -plane under the influence of a central force $\vec{F} = -k\vec{r}$ (attraction force proportional to distance from the origin), where $k = 200 \text{ N/m}$ and \vec{r} is the position of the particle relative to the force center. Neglect all other forces.

- Show that circular trajectories are possible, and determine the relation between speed v and circular radius r_0 which must hold on a circular trajectory. [hint: Write $\vec{F} = m\vec{a}$, break into x and y components, solve the separate scalar equations, pick fortuitous values for the free constants in your solutions.]
- It turns out that trajectories are in general elliptical, as depicted in the diagram.

For a particular elliptical trajectory with $a = 1 \text{ m}$ and $b = 0.8 \text{ m}$, the velocity of the particle at point 1 is observed to be perpendicular to the radial direction, with magnitude v_1 , as shown. When the particle reaches point 2, its velocity is again perpendicular to the radial direction.

Determine the speed increment Δv which would have to be added (instantaneously) to the particle's speed at point 2 to transfer it to the circular trajectory through point 2 (the dotted curve). Express your answer in terms of v_1 .

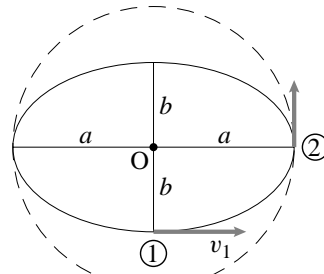

problem 5.137:

(Filename: pfigure.blue.72.1)

5.10 Coupled motions of particles in space

5.138 Linear momentum balance for general systems with multiple interacting parts moving more or less independently reduces to $\vec{F} = m\vec{a}$ if you interpret the terms correctly. What does this mean? What is \vec{F} ? What is m ? What is \vec{a} ?

5.139 A particle of mass $m_1 = 6 \text{ kg}$ and a particle of mass $m_2 = 10 \text{ kg}$ are moving in the xy -plane. At a particular instant of interest, particle 1 has position, velocity, and acceleration $\vec{r}_1 = 3 \text{ m}\hat{i} + 2 \text{ m}\hat{j}$, $\vec{v}_1 = -16 \text{ m/s}\hat{i} + 6 \text{ m/s}\hat{j}$, and $\vec{a}_1 = 10 \text{ m/s}^2\hat{i} - 24 \text{ m/s}^2\hat{j}$, respectively, and particle 2 has position, velocity, and acceleration $\vec{r}_2 = -6 \text{ m}\hat{i} - 4 \text{ m}\hat{j}$, $\vec{v}_2 = 8 \text{ m/s}\hat{i} + 4 \text{ m/s}\hat{j}$, and $\vec{a}_2 = 5 \text{ m/s}^2\hat{i} - 16 \text{ m/s}^2\hat{j}$, respectively.

- Find the linear momentum \vec{L} and its rate of change $\dot{\vec{L}}$ of each particle at the instant of interest.
- Find the linear momentum \vec{L} and its rate of change $\dot{\vec{L}}$ of the system of the two particles at the instant of interest.
- Find the center of mass of the system at the instant of interest.
- Find the velocity and acceleration of the center of mass.

5.140 A particle of mass $m_1 = 5 \text{ kg}$ and a particle of mass $m_2 = 10 \text{ kg}$ are moving in space. At a particular instant of interest, particle 1 has position, velocity, and acceleration

$$\begin{aligned} \vec{r}_1 &= 1 \text{ m}\hat{i} + 1 \text{ m}\hat{j} \\ \vec{v}_1 &= 2 \text{ m/s}\hat{j} \\ \vec{a}_1 &= 3 \text{ m/s}^2\hat{k} \end{aligned}$$

respectively, and particle 2 has position, velocity, and acceleration

$$\begin{aligned} \vec{r}_2 &= 2 \text{ m}\hat{i} \\ \vec{v}_2 &= 1 \text{ m/s}\hat{k} \\ \vec{a}_2 &= 1 \text{ m/s}^2\hat{j} \end{aligned}$$

respectively. For the system of particles at the instant of interest, find its

- linear momentum \vec{L} ,
- rate of change of linear momentum $\dot{\vec{L}}$,
- angular momentum about the origin \vec{H}_O ,
- rate of change of angular momentum about the origin $\dot{\vec{H}}_O$,
- kinetic energy E_K , and
- rate of change of kinetic energy.

5.141 Two particles each of mass m are connected by a massless elastic spring of spring constant k and unextended length $2R$. The system slides without friction on a horizontal table, so that no net external forces act.

- Is the total linear momentum conserved? Justify your answer.
- Can the center of mass accelerate? Justify your answer.
- Draw free body diagrams for each mass.
- Derive the equations of motion for each mass in terms of cartesian coordinates.
- What are the total kinetic and potential energies of the system?
- For constant values and initial conditions of your choosing plot the trajectories of the two particles and of the center of mass (on the same plot).

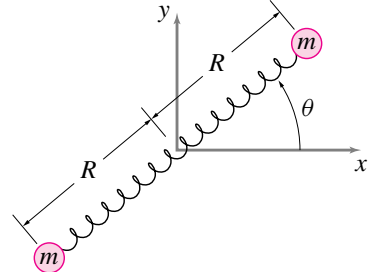

problem 5.141:

(Filename: pfigure.blue.65.2)

5.142 Two ice skaters whirl around one another. They are connected by a linear elastic cord whose center is stationary in space. We wish to consider the motion of one of the skaters by modeling her as a mass m held by a cord that exerts k Newtons for each meter it is extended from the central position.

- Draw a free body diagram showing the forces that act on the mass is at an arbitrary position.
- Write the differential equations that describe the motion.
- Describe in physical and mathematical terms the nature of the motion for the three cases
 - $\omega < \sqrt{k/m}$;
 - $\omega = \sqrt{k/m}$;
 - $\omega > \sqrt{k/m}$.

(You are not asked to solve the equation of motion.)

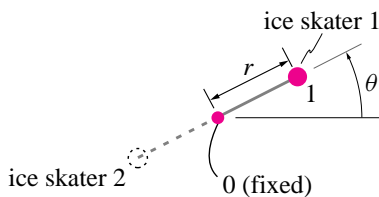

problem 5.142:

(Filename:pfigure.blue.154.1)

5.143 Theory question. If you are given the total mass, the position, the velocity, and the acceleration of the center of mass of a system of particles can you find the angular momentum \vec{H}_O of the system, where O is not at the center of mass? If so, how and why? If not, then give a reason and/or a counter example. *

5.144 The equation $(\vec{v}'_1 - \vec{v}'_2) \cdot \hat{n} = e(\vec{v}_2 - \vec{v}_1) \cdot \hat{n}$ relates relative velocities of two point masses before and after frictionless impact in the normal direction \hat{n} of the impact. If $\vec{v}'_1 = v_{1x}\hat{i} + v_{1y}\hat{j}$, $\vec{v}'_2 = -v_0\hat{i}$, $e = 0.5$, $\vec{v}_2 = \vec{0}$, $\vec{v}_1 = 2\text{ ft/s}\hat{i} - 5\text{ ft/s}\hat{j}$, and $\hat{n} = \frac{1}{\sqrt{2}}(\hat{i} + \hat{j})$, find the scalar equation relating the velocities in the normal direction.

5.145 See also problem 5.150. Assuming θ , v_0 , and e to be known quantities, write the following equations in matrix form set up to solve for v'_{Ax} and v'_{Ay} :

$$\begin{aligned} \sin\theta v'_{Ax} + \cos\theta v'_{Ay} &= ev_0 \cos\theta \\ \cos\theta v'_{Ax} - \sin\theta v'_{Ay} &= v_0 \sin\theta. \end{aligned}$$

5.146 Set up the following equations in matrix form and solve for v_A and v_B , if $v_0 = 2.6\text{ m/s}$, $e = 0.8$, $m_A = 2\text{ kg}$, and $m_B = 500\text{g}$:

$$\begin{aligned} m_A v_0 &= m_A v_A + m_B v_B \\ -e v_0 &= v_A - v_B. \end{aligned}$$

5.147 The following three equations are obtained by applying the principle of conservation of linear momentum on some system.

$$\begin{aligned} m_0 v_0 &= 24.0\text{ m/s } m_a - 0.67 m_B v_B - 0.58 m_C v_C \\ 0 &= 36.0\text{ m/s } m_A + 0.33 m_B v_B + 0.3 m_C v_C \\ 0 &= 23.3\text{ m/s } m_A - 0.67 m_B v_B - 0.58 m_C v_C. \end{aligned}$$

Assume v_0 , v_B , and v_C are the only unknowns. Write the equations in matrix form set up to solve for the unknowns.

5.148 See also problem 5.149. The following three equations are obtained to solve for v'_{Ax} , v'_{Ay} , and v'_{Bx} :

$$\begin{aligned} (v'_{Bx} - v'_{Ax}) \cos\theta &= v'_{Ay} \sin\theta - 10\text{ m/s} \\ v'_{Ax} \sin\theta &= v'_{Ay} \cos\theta - 36\text{ m/s} \\ m_B v'_{Bx} + m_A v'_{Ax} &= (-60\text{ m/s}) m_A. \end{aligned}$$

Set up these equations in matrix form.

5.149 Solve for the unknowns v'_{Ax} , v'_{Ay} , and v'_{Bx} in problem 5.148 taking $\theta = 50^\circ$, $m_A = 1.5 m_B$ and $m_B = 0.8\text{ kg}$. Use any computer program.

5.150 Using the matrix form of equations in Problem 5.145, solve for v'_{Ax} and v'_{Ay} if $\theta = 20^\circ$ and $v_0 = 5\text{ ft/s}$.

5.151 Two frictionless masses $m_A = 2\text{ kg}$ and mass $m_B = 5\text{ kg}$ travel on straight collinear paths with speeds $V_A = 5\text{ m/s}$ and $V_B = 1\text{ m/s}$, respectively. The masses collide since $V_A > V_B$. Find the amount of energy lost in the collision assuming normal motion is decoupled from tangential motion. The coefficient of restitution is $e = 0.5$.



problem 5.151:

(Filename:Danef94s3q7)

5.152 Two frictionless pucks sliding on a plane collide as shown in the figure. Puck A is initially at rest. Given that $(V_B)_i = 1.0\text{ m/s}$, $(V_A)_i = 0$, and $(V_A)_f = 0.5\text{ m/s}$, find the approach angle ϕ and rebound angle γ . The coefficient of restitution is $e = 0.9$.

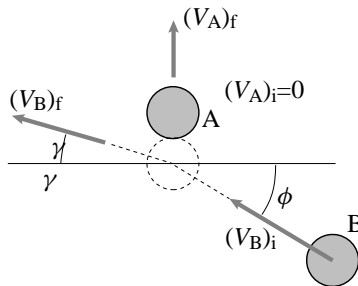

problem 5.152:

(Filename:Danef94s2q8)

5.153 Reconsider problem 5.152. Given instead that $\gamma = 30^\circ$, $(V_A)_i = 0$, and $(V_A)_f = 0.5\text{ m/s}$, find the initial velocity of puck B.

5.154 A bullet of mass m with initial speed v_0 is fired in the horizontal direction through block A of mass m_A and becomes embedded in block B of mass m_B . Each block is suspended by thin wires. The bullet causes A and B to start moving with speed of v_A and v_B respectively. Determine

- the initial speed v_0 of the bullet in terms of v_A and v_B , *
- the velocity of the bullet as it travels from block A to block B, and *
- the energy loss due to friction as the bullet (1) moves through block A and (2) penetrates block B. *

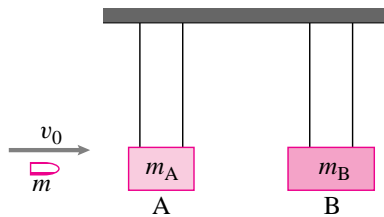

problem 5.154:

(Filename:pfigure.blue.23.1)

5.155 A massless spring with constant k is held compressed a distance δ from its relaxed length by a thread connecting blocks A and B which are still on a frictionless table. The blocks have mass m_A and m_B , respectively. The thread is suddenly but gently cut, the blocks fly apart and the spring falls to the ground. Find the speed of block A as it slides away. *

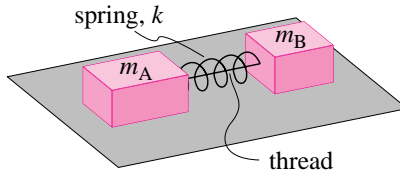

problem 5.155:

(Filename:pfigure.blue.32.2)

Problems for Chapter 6

Constrained straight line motion

6.1 1-D constrained motion and pulleys

6.1 Write the following equations in matrix form for a_B , a_C , and T :

$$\begin{aligned} 4a_B + a_C &= 0 \\ 2T &= -(25\text{ kg}) a_B \\ 64\text{ kg m/s}^2 &= T + (10\text{ kg}) a_C. \end{aligned}$$

6.2 The two blocks, $m_1 = m_2 = m$, are connected by an inextensible string AB . The string can only withstand a tension T_{cr} . Find the maximum value of the applied force P so that the string does not break. The sliding coefficient of friction between the blocks and the ground is μ .

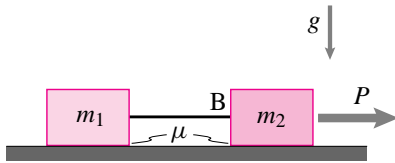

problem 6.2:

(Filename: Dane94s3q5)

6.3 A train engine of mass m pulls and accelerates on level ground N cars each of mass m . The power of the engine is P_t and its speed is v_t . Find the tension T_n between car n and car $n+1$. Assume there is no resistance to rolling for all of the cars. Assume the cars are connected with rigid links. *

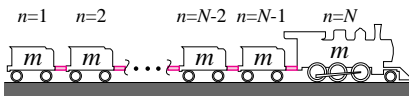

problem 6.3:

(Filename: pfigure.newtrain)

6.4 Two blocks, each of mass m , are connected together across their tops by a massless string of length S ; the blocks' dimensions are small compared to S . They slide down a slope of angle θ . Do not neglect gravity but do neglect friction.

- Draw separate free body diagrams of each block, the string, and the system of the two blocks and string.
- Write separate equations for linear momentum balance for each block, the string, and the system of blocks and string.
- What is the acceleration of the center of mass of the two blocks?

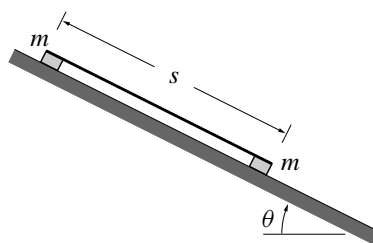

problem 6.5:

(Filename: pfigure.blue.27.1a)

- What is the force in the string?
- What is the speed of the center of mass for the two blocks after they have traveled a distance d down the slope, having started from rest. [Hint: You need to dot your momentum balance equations with a unit vector along the ramp in order to reduce this problem to a problem in one dimensional mechanics.]

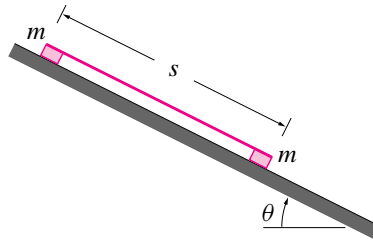

problem 6.4:

(Filename: pfigure.blue.27.1)

6.5 Two blocks, each of mass m , are connected together across their tops by a massless string of length S ; the blocks' dimensions are small compared to S . They slide down a slope of angle θ . The materials are such that the coefficient of dynamic friction on the top block is μ and on the bottom block is $\mu/2$.

- Draw separate free body diagrams of each block, the string, and the system of the two blocks and string.
- Write separate equations for linear momentum balance for each block, the string, and the system of blocks and string.
- What is the acceleration of the center of mass of the two blocks?
- What is the force in the string?
- What is the speed of the center of mass for the two blocks after they have traveled a distance d down the slope, having started from rest.
- How would your solutions to parts (a) and (c) differ in the following two variations: i.) If the two blocks were interchanged with the slippery one on top or ii.) if the string were replaced by a massless rod? Qualitative responses to this part are sufficient.

6.6 A cart of mass M , initially at rest, can move horizontally along a frictionless track. When $t = 0$, a force F is applied as shown to the cart. During the acceleration of M by the force F , a small box of mass m slides along the cart from the front to the rear. The coefficient of friction between the cart and box is μ , and it is assumed that the acceleration of the cart is sufficient to cause sliding.

- Draw free body diagrams of the cart, the box, and the cart and box together.
- Write the equation of linear momentum balance for the cart, the box, and the system of cart and box.
- Show that the equations of motion for the cart and box can be combined to give the equation of motion of the mass center of the system of two bodies.
- Find the displacement of the cart at the time when the box has moved a distance ℓ along the cart.

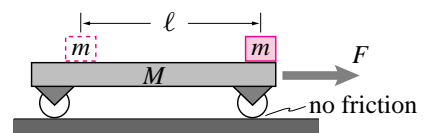

problem 6.6:

(Filename: pfigure.blue.28.1)

6.7 A motor at B allows the block of mass $m = 3\text{ kg}$ shown in the figure to accelerate downwards at 2 m/s^2 . There is gravity. What is the tension in the string AB ?

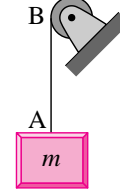

problem 6.7:

(Filename: pfigure.blue.12.2)

6.8 For the mass and pulley system shown in the figure, the point of application A of the force moves twice as fast as the mass. At some instant in time t , the speed of the mass is \dot{x} to the left. Find the input power to the system at time t .

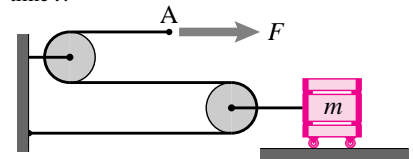

problem 6.8:

(Filename: pfig.2.3.rp8)

6.9 Pulley and masses. Two masses connected by an inextensible string hang from an ideal pulley.

- a) Find the downward acceleration of mass B . Answer in terms of any or all of m_A, m_B, g , and the present velocities of the blocks. As a check, your answer should give $a_B = g$ when $m_A = 0$ and $a_B = 0$ when $m_A = m_B$. *
- b) Find the tension in the string. As a check, your answer should give $T = m_B g = m_A g$ when $m_A = m_B$ and $T = 0$ when $m_A = 0$. *

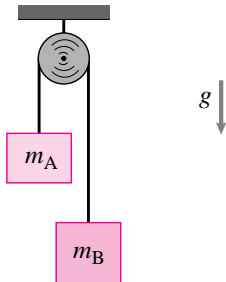

problem 6.9:

(Filename: pfigure3.f95p1p2)

6.10 The blocks shown are released from rest. Make reasonable assumptions about strings, pulleys, string lengths, and gravity.

- a) What is the acceleration of block A at $t = 0^+$ (just after release)?
- b) What is the speed of block B after it has fallen 2 meters?

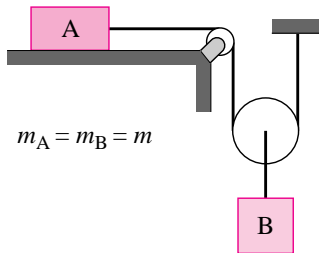

problem 6.10:

(Filename: pfigure.blue.29.2)

6.11 What is the acceleration of block A? Use $g = 10 \text{ m/s}^2$. Assume the string is massless and that the pulleys are massless, round, and have frictionless bearings.

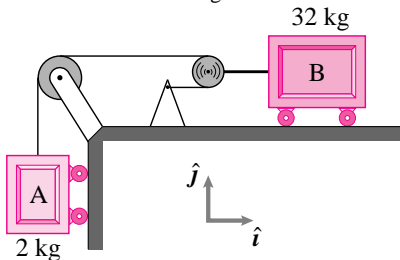

problem 6.11:

(Filename: pfigure.f93q4)

6.12 For the system shown in problem 6.9, find the acceleration of mass B using energy balance ($P = \dot{E}_K$).

6.13 For the various situations pictured, find the acceleration of the mass A and the point B shown using balance of linear momentum

($\sum \vec{F} = m\vec{a}$). Define any variables, coordinates or sign conventions that you need to do your calculations and to define your solution. *

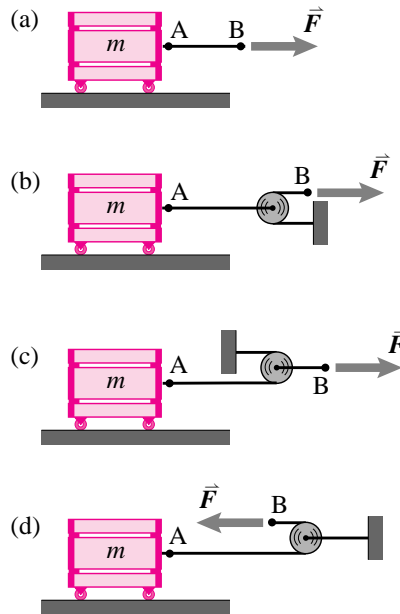

problem 6.13:

(Filename: pulley1)

6.14 For each of the various situations pictured in problem 6.13 find the acceleration of the mass using energy balance ($P = \dot{E}_K$). Define any variables, coordinates, or sign conventions that you need to do your calculations and to define your solution.

6.15 What is the ratio of the acceleration of point A to that of point B in each configuration? In both cases, the strings are inextensible, the pulleys massless, and the mass and force the same. *

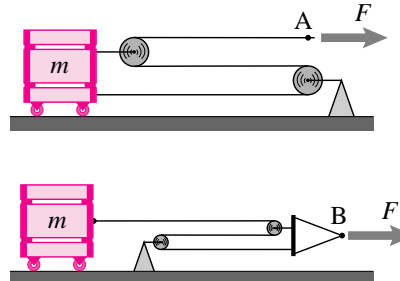

problem 6.15:

(Filename: sum95.p1.p3)

6.16 See also problem 6.17. Find the acceleration of points A and B in terms of F and m . Assume that the carts stay on the ground, have good (frictionless) bearings, and have wheels of negligible mass.

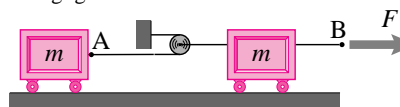

problem 6.16:

(Filename: pfigure.s94q5p1)

6.17 For the situation pictured in problem 6.16 find the accelerations of the two masses using energy balance ($P = \dot{E}_K$). Define any variables, coordinates, or sign conventions that you need to do your calculations and to define your solution.

6.18 See also problem 6.19. For the various situations pictured, find the acceleration of the mass A and the point B shown using balance of linear momentum ($\sum \vec{F} = m\vec{a}$). Define any variables, coordinates or sign conventions that you need to do your calculations and to define your solution.

- a) *
- b) *

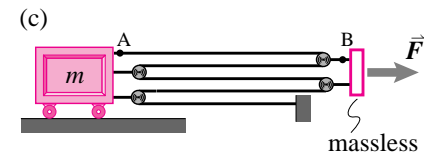
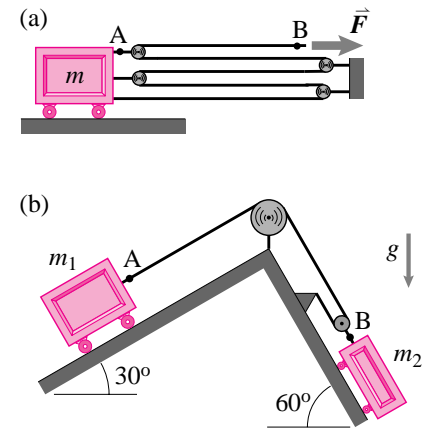

problem 6.18:

(Filename: pulley4)

6.19 For the various situations pictured in problem 6.18 find the acceleration of the mass using energy balance ($P = \dot{E}_K$). Define any variables, coordinates, or sign conventions that you need to do your calculations and to define your solution.

6.20 A person of mass m , modeled as a rigid body is sitting on a cart of mass $M > m$ and pulling the massless inextensible string towards herself. The coefficient of friction between her seat and the cart is μ . All wheels and pulleys are massless and frictionless. Point B is attached to the cart and point A is attached to the rope.

- a) If you are given that she is pulling rope in with acceleration a_0 relative to herself (that is, $\mathbf{a}_{A/B} \equiv \mathbf{a}_A - \mathbf{a}_B = -a_0 \hat{i}$) and that she is not slipping relative to the cart, find \mathbf{a}_A . (Answer in terms of some or all of m, M, g, μ, \hat{i} and a_0 .)

- b) Find the largest possible value of a_0 without the person slipping off the cart? (Answer in terms of some or all of m, M, g and μ . You may assume her legs get out of the way if she slips backwards.)
- c) If instead, $m < M$, what is the largest possible value of a_0 without the person slipping off the cart? (Answer in terms of some or all of m, M, g and μ . You may assume her legs get out of the way if she slips backwards.)

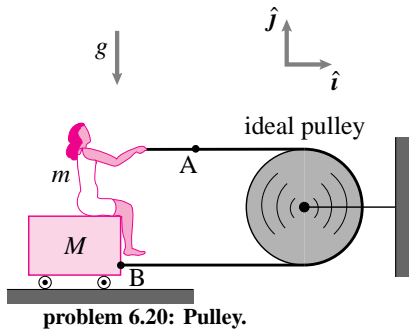

(Filename:s97p2.2)

6.21 Two blocks and a pulley. Two equal masses are stacked and tied together by the pulley as shown. All bearings are frictionless. All rotating parts have negligible mass. Find

- the acceleration of point A, and
- the tension in the line.

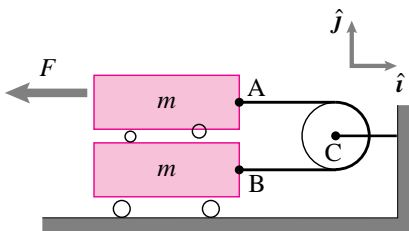

(Filename:p.s96.p1.1)

6.22 The pulleys are massless and frictionless. Neglect air friction. Include gravity. x measures the vertical position of the lower mass from equilibrium. y measures the vertical position of the upper mass from equilibrium. What is the natural frequency of vibration of this system? *

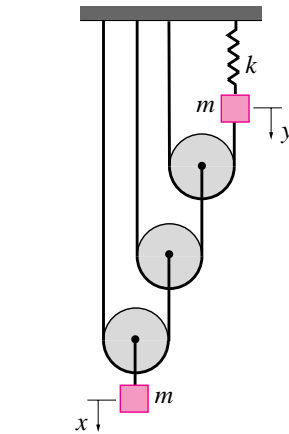

(Filename:pfigure.s95q4)

6.23 See also problem 6.24. For the situation pictured, find the acceleration of the mass A and the points B and C shown using balance of linear momentum ($\sum \vec{F} = m\vec{a}$). Define any variables, coordinates or sign conventions that you need to do your calculations and to define your solution. [Hint: the situation with point C is tricky and the answer is subtle.]

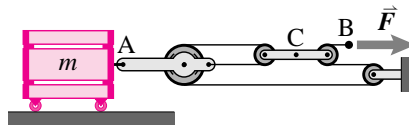

(Filename:pulley2)

6.24 For situation pictured in problem 6.23, find the acceleration of point A using energy balance ($P = \dot{E}_K$). Define any variables, coordinates, or sign conventions that you need to do your calculations and to define your solution.

6.25 Pulley and spring. For the mass hanging at the right, find the period of oscillation. Assume a massless pulley with good bearings. The massless string is inextensible. Only vertical motion is of interest. There is gravity. [Hint: Draw FBD, carefully keep track of string length to figure spring stretch, set up equations of motion and solve them.]

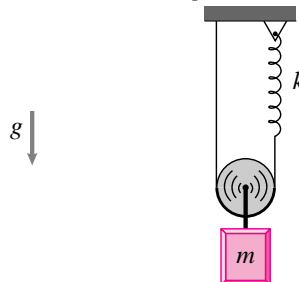

(Filename:pfigure.s94h4p4)

6.26 The spring-mass system shown ($m = 10$ slugs ($\equiv \text{lb} \cdot \text{sec}^2/\text{ft}$), $k = 10 \text{ lb}/\text{ft}$) is excited by moving the free end of the cable vertically according to $\delta(t) = 4 \sin(\omega t)$ in, as shown in the figure. Assuming that the cable is inextensible and massless and that the pulley is massless, do the following.

- Derive the equation of motion for the block in terms of the displacement x from the static equilibrium position, as shown in the figure.
- If $\omega = 0.9 \text{ rad/s}$, check to see if the pulley is always in contact with the cable (ignore the transient solution).

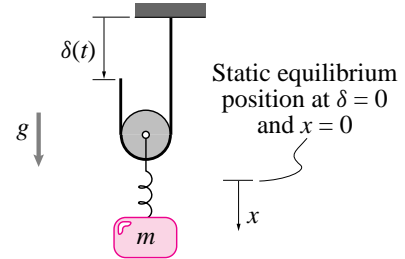

(Filename:pfigure.blue.151.1)

6.27 The block of mass m hanging on the spring with constant k and a string shown in the figure is forced (by an unseen agent) with the force $F = A \sin(\omega t)$. (Do not neglect gravity). The pulley is massless.

- What is the differential equation governing the motion of the block? You may assume that the only motion is vertical motion. *
- Given A, m and k , for what values of ω would the string go slack at some point in the cyclical motion? (You should neglect the homogeneous solution to the differential equation.) *

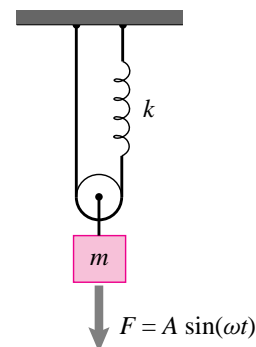

(Filename:pfigure.blue.155.1)

6.28 Block A, with mass m_A , is pulled to the right a distance d from the position it would have if the spring were relaxed. It is then released from rest. Assume ideal string, pulleys and wheels. The spring has constant k .

- What is the acceleration of block A just after it is released (in terms of k, m_A , and d)? *

b) What is the speed of the mass when the mass passes through the position where the spring is relaxed? *

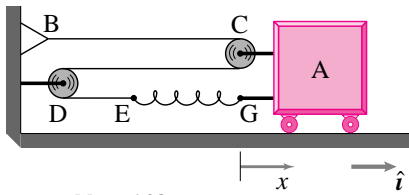

problem 6.28:

(Filename:pfigure.f93q5)

6.29 What is the static displacement of the mass from the position where the spring is just relaxed?

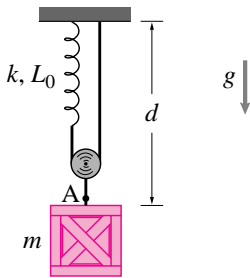

problem 6.29:

(Filename:pulley3.a)

6.30 For the two situations pictured, find the acceleration of point A shown using balance of linear momentum ($\sum \vec{F} = m\vec{a}$). Assuming both masses are deflected an equal distance from the position where the spring is just relaxed, how much smaller or bigger is the acceleration of block (b) than of block(a). Define any variables, coordinate system origins, coordinates or sign conventions that you need to do your calculations and to define your solution.

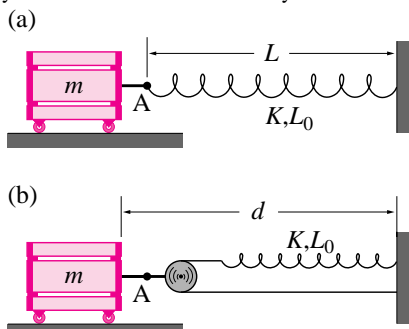

problem 6.30:

(Filename:pulley3)

6.31 For each of the various situations pictured in problem 6.30, find the acceleration of the mass using energy balance ($P = \dot{E}_K$). Define any variables, coordinates, or sign conventions that you need to do your calculations and to define your solution.

6.2 2D and 3D forces even though the motion is straight

6.32 Mass pulled by two strings. F_1 and F_2 are applied so that the system shown accelerates to the right at 5 m/s^2 (i.e., $\mathbf{a} = 5 \text{ m/s}^2 \hat{i} + 0 \hat{j}$) and has no rotation. The mass of D and forces F_1 and F_2 are unknown. What is the tension in string AB?

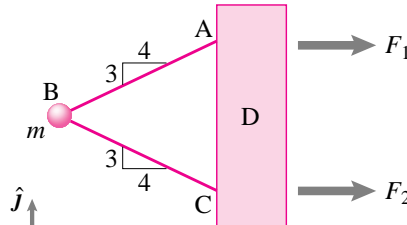

problem 6.32:

(Filename:pg9.1)

6.33 A point mass m is attached to a piston by two inextensible cables. The piston has upwards acceleration $a_y \hat{j}$. There is gravity. In terms of some or all of m , g , d , and a_y find the tension in cable AB. *

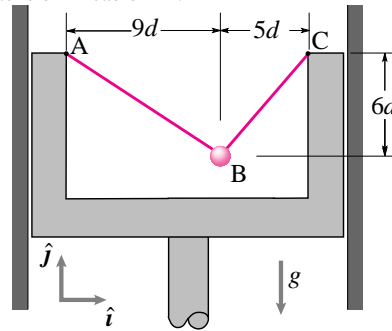

problem 6.33:

(Filename:ch3.13)

6.34 A point mass of mass m moves on a frictional surface with coefficient of friction μ and is connected to a spring with constant k and unstretched length ℓ . There is gravity. At the instant of interest, the mass is at a distance x to the right from its position where the spring is unstretched and is moving with $\dot{x} > 0$ to the right.

- Draw a free body diagram of the mass at the instant of interest.
- At the instant of interest, write the equation of linear momentum balance for the block evaluating the left hand side as explicitly as possible. Let the acceleration of the block be $\vec{a} = \ddot{x} \hat{i}$.

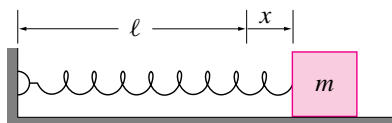

problem 6.34:

(Filename:ch2.10a)

6.35 Find the tension in two strings. Consider the mass at B (2 kg) supported by two strings in the back of a truck which has acceleration of 3 m/s^2 . Use your favorite value for the gravitational constant. What is the tension T_{AB} in the string AB in Newtons?

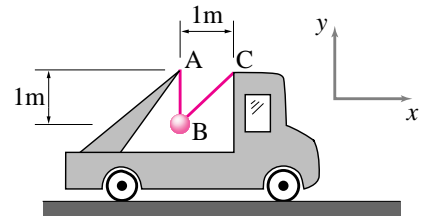

problem 6.35:

(Filename:pfigure.s94h2p8)

6.36 Guyed plate on a cart A uniform rectangular plate ABCD of mass m is supported by a rod DE and a hinge joint at point B. The dimensions are as shown. The cart has acceleration $a_x \hat{i}$ due to a force F . There is gravity. What must the acceleration of the cart be in order for the rod DE to be in tension? *

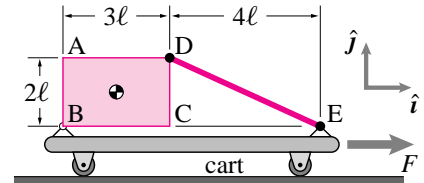

problem 6.36: Uniform plate supported by a hinge and a cable on an accelerating cart.

(Filename:tfigure3.2D.a.guyed)

6.37 A uniform rectangular plate of mass m is supported by two inextensible cables AB and CD and by a hinge at point E on the cart as shown. The cart has acceleration $a_x \hat{i}$ due to a force not shown. There is gravity.

- Draw a free body diagram of the plate.
- Write the equation of linear momentum balance for the plate and evaluate the left hand side as explicitly as possible.
- Write the equation for angular momentum balance about point E and evaluate the left hand side as explicitly as possible.

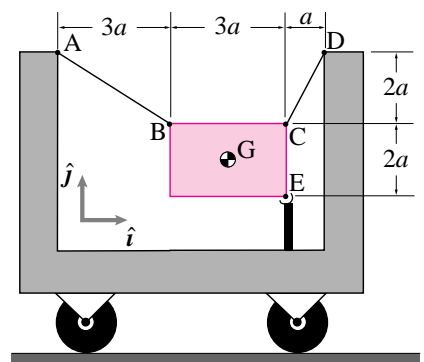

problem 6.37:

(Filename:ch2.12)

6.38 See also problem 6.67. A uniform rectangular plate of mass m is supported by an inextensible cable CD and a hinge joint at point E on the cart as shown. The hinge joint is attached to a rigid column welded to the floor of the cart. The cart is at rest. There is gravity. Find the tension in cable CD .

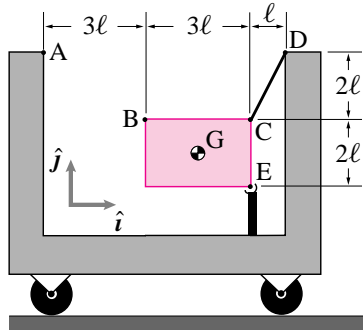

problem 6.38:

(Filename:ch3.11.b)

6.39 A uniform rectangular plate of mass m is supported by an inextensible cable AB and a hinge joint at point E on the cart as shown. The hinge joint is attached to a rigid column welded to the floor of the cart. The cart has acceleration $a_x \hat{i}$. There is gravity. Find the tension in cable AB . (What's 'wrong' with this problem? What if instead point B was at the bottom left hand corner of the plate?)*

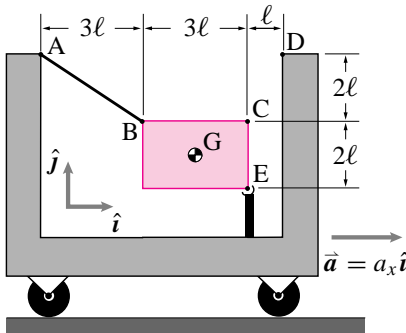

problem 6.39:

(Filename:ch3.11a)

6.40 See also 6.41. A block of mass m is sitting on a frictionless surface and acted upon at point E by the horizontal force P through the center of mass. Draw a free body diagram of the block. There is gravity. Find the acceleration of the block and reactions on the block at points A and B .

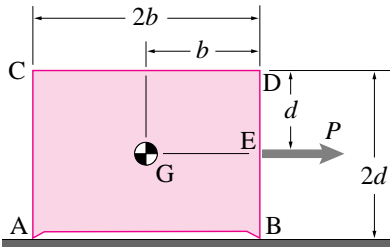

problem 6.40:

(Filename:ch3.9)

6.41 Reconsider the block in problem 6.40. This time, find the acceleration of the block and the reactions at A and B if the force P is applied instead at point D . Are the acceleration and the reactions on the block different from those found if P is applied at point E ?

6.42 A block of mass m is sitting on a frictional surface and acted upon at point D by the horizontal force P . The block is resting on a sharp edge at point B and is supported by an ideal wheel at point A . There is gravity. Assuming the block is sliding with coefficient of friction μ at point B , find the acceleration of the block and the reactions on the block at points A and B .

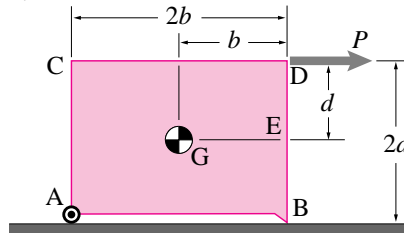

problem 6.42:

(Filename:ch3.12)

6.43 A force F_C is applied to the corner C of a box of weight W with dimensions and center of gravity at G as shown in the figure. The coefficient of sliding friction between the floor and the points of contact A and B is μ . Assuming that the box slides when F_C is applied, find the acceleration of the box and the reactions at A and B in terms of W , F_C , θ , b , and d .

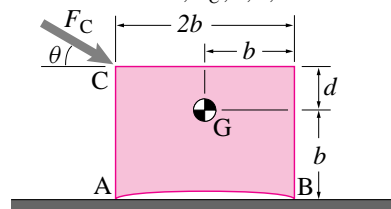

problem 6.43:

(Filename:Mikes92p3)

6.44 Forces of rod on a cart. A uniform rod with mass m_r rests on a cart (mass m_c) which is being pulled to the right. The rod is hinged at one end (with a frictionless hinge) and has no friction at the contact with the cart. The cart is rolling on wheels that are modeled as having no mass and no bearing friction (ideal massless wheels). Find:

- The force on the rod from the cart at point B . Answer in terms of g , m_r , m_c , θ and F .
- The force on the rod from the cart at point A .

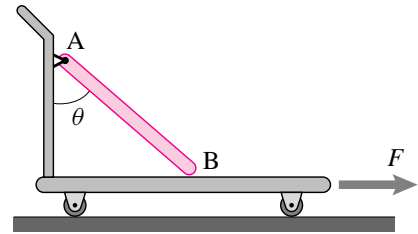

problem 6.44:

(Filename:pfigure.s94h3p3)

6.45 At the instant shown, the mass is moving to the right at speed $v = 3$ m/s. Find the rate of work done on the mass.

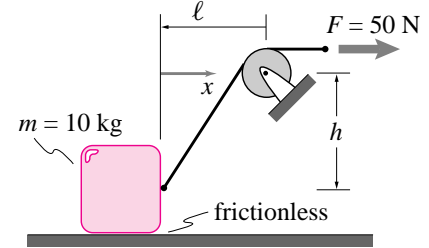

problem 6.45:

(Filename:pfig2.3.rp9)

6.46 The box shown in the figure is dragged in the x -direction with a constant acceleration $\vec{a} = 0.5$ m/s² \hat{i} . At the instant shown, the velocity of (every point on) the box is $\vec{v} = 0.8$ m/s \hat{i} .

- Find the linear momentum of the box.
- Find the rate of change of linear momentum of the box.
- Find the angular momentum of the box about the contact point O .
- Find the rate of change of angular momentum of the box about the contact point O .

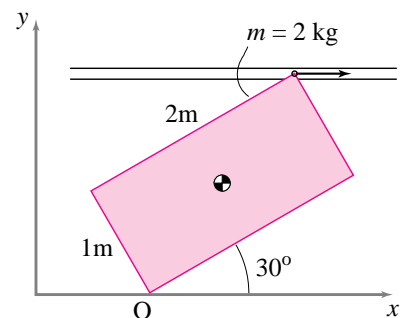

problem 6.46:

(Filename:pfigure3.mom.rp1)

6.47 (See also problem 4.15.) The groove and disk accelerate upwards, $\vec{a} = a \hat{j}$. Neglecting gravity, what are the forces on the disk due to the groove?

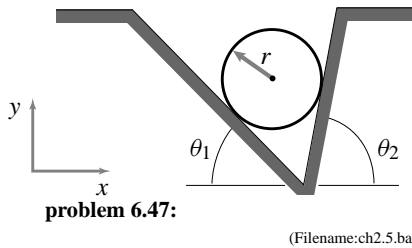

problem 6.47:

(Filename:ch2.5.ba)

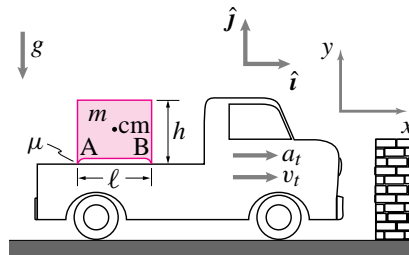

problem 6.48:

(Filename:pfigure.blue.22.1)

6.48 The following problems concern a box that is in the back of a pickup truck. The pickup truck is accelerating forward at an acceleration of a_t . The truck's speed is v_t . The box has sharp feet at the front and back ends so the only place it contacts the truck is at the feet. The center of mass of the box is at the geometric center of the box. The box has height h , length l and depth w (into the paper.) Its mass is m . There is gravity. The friction coefficient between the truck and the box edges is μ .

In the problems below you should express your solutions in terms of the variables given in the figure, l , h , μ , m , g , a_t , and v_t . If any variables do not enter the expressions comment on why they do not. In all cases you may assume that the box does not rotate (though it might be on the verge of doing so).

- Assuming the box does not slide, what is the total force that the truck exerts on the box (i.e. the sum of the reactions at A and B)?
- Assuming the box does not slide what are the reactions at A and B? [Note: You cannot find both of them without additional assumptions.]
- Assuming the box does slide, what is the total force that the truck exerts on the box?
- Assuming the box does slide, what are the reactions at A and B?
- Assuming the box does not slide, what is the maximum acceleration of the truck for which the box will not tip over (hint: just at that critical acceleration what is the vertical reaction at B)?
- What is the maximum acceleration of the truck for which the block will not slide?
- The truck hits a brick wall and stops instantly. Does the block tip over?

Assuming the block does not tip over, how far does it slide on the truck before stopping (assume the bed of the truck is sufficiently long)?

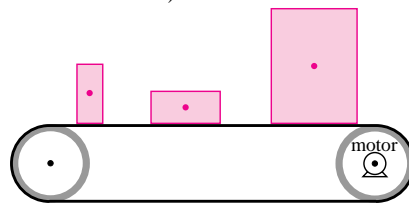

problem 6.49:

(Filename:pfigure.f93q3)

6.50 After failure of her normal brakes, a driver pulls the emergency brake of her old car. This action locks the rear wheels (friction coefficient $= \mu$) but leaves the well lubricated and light front wheels spinning freely. The car, braking inadequately as is the case for rear wheel braking, hits a stiff and slippery phone pole which compresses the car bumper. The car bumper is modeled here as a linear spring (constant $= k$, rest length $= l_0$, present length $= l_s$). The car is still traveling forward at the moment of interest. The bumper is at a height h_b above the ground. Assume that the car, excepting the bumper, is a non-rotating rigid body and that the wheels remain on the ground (that is, the bumper is compliant but the suspension is stiff).

- What is the acceleration of the car in terms of g , m , μ , l_f , l_r , k , h_b , h_{cm} , l_0 , and l_s (and any other parameters if needed)?

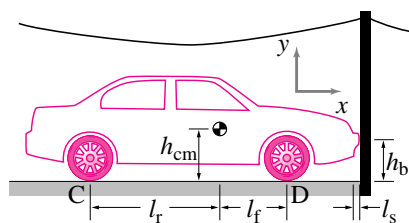

problem 6.50:

(Filename:pfigure.s94q4p1)

6.51 Car braking: front brakes versus rear brakes versus all four brakes. There are a few puzzles in dynamics concerning the differences between front and rear braking of a car. Here is one you can deal with now. What is the peak deceleration of a car when you apply: the front brakes till they skid, the rear brakes till they skid, and all four brakes till they skid? Assume that the coefficient of friction between rubber and road is $\mu = 1$ (about right, the coefficient of friction between rubber and road varies between about .7 and 1.3) and that $g = 10 \text{ m/s}^2$ (2% error). Pick the dimensions and mass of the car, but assume the center of mass height h is above the ground. The height h , should be less than half the wheel base w , the distance between the front and rear wheel. Further assume that the CM is halfway between the front and back wheels (i.e., $l_f = l_r = w/2$). Assume also that the car has a stiff suspension so the car does not move up or down or tip during braking; i. e., the car does not rotate in the xy -plane. Neglect the mass of the rotating wheels in the linear and angular momentum balance equations. Treat this problem as two-dimensional problem; i. e., the car is symmetric left to right, does not turn left or right, and that the left and right wheels carry the same loads. To organize your work, here are some steps to follow.

- Draw a FBD of the car assuming rear wheel is skidding. The FBD should show the dimensions, the gravity force, what you know *a priori* about the forces on the wheels from the ground (i.e., that the friction force $F_f = \mu N_r$, and that there is no friction at the front wheels), and the coordinate directions. Label points of interest that you will use in your momentum balance equations. (Hint: also draw a free body diagram of the rear wheel.)
- Write down the equation of linear momentum balance.
- Write down the equation of angular momentum balance relative to a point of your choosing. Some particularly useful points to use are: the point above the front wheel and at the height of the center of mass; the point at the height of the center of mass, behind the rear wheel that makes a 45 degree angle line down to the rear wheel ground contact point; and the point on the ground straight under the front wheel that is as deep as the wheel base is long.
- Solve the momentum balance equations for the wheel contact forces and the deceleration of the car. If you have used any or all of the recommendations from part (c) you will have the pleasure of only solving one equation in one unknown at a time. *
- Repeat steps (a) to (d) for front-wheel skidding. Note that the advantageous points to use for angular momentum balance are now different. Does a car

stop faster or slower or the same by skidding the front instead of the rear wheels? Would your solution to (e) be different if the center of mass of the car was at ground level ($h=0$)? *

- f) Repeat steps (a) to (d) for all-wheel skidding. There are some shortcuts here. You determine the car deceleration without ever knowing the wheel reactions (or using angular momentum balance) if you look at the linear momentum balance equations carefully. *
- g) Does the deceleration in (f) equal the sum of the deceleration in (d) and (e)? Why or why not? *
- h) What peculiarity occurs in the solution for front-wheel skidding if the wheel base is twice the height of the CM above ground and $\mu = 1$? *
- i) What impossibility does the solution predict if the wheel base is shorter than twice the CM height? What wrong assumption gives rise to this impossibility? What would really happen if one tried to skid a car this way? *

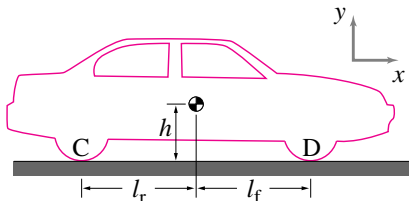

problem 6.51:

(Filename: pfigure.s94h3p6)

6.52 At time $t = 0$, the block of mass m is released at rest on the slope of angle ϕ . The coefficient of friction between the block and slope is μ .

- What is the acceleration of the block for $\mu > 0$? *
- What is the acceleration of the block for $\mu = 0$? *
- Find the position and velocity of the block as a function of time for $\mu > 0$. *
- Find the position and velocity of the block as a function of time for $\mu = 0$. *

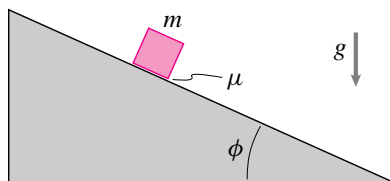

problem 6.52:

(Filename: Dane94s1q5)

6.53 A small block of mass m_1 is released from rest at altitude h on a frictionless slope of angle α . At the instant of release, another small block of mass m_2 is dropped vertically from rest at

the same altitude. The second block does not interact with the ramp. What is the velocity of the first block relative to the second block after t seconds have passed?

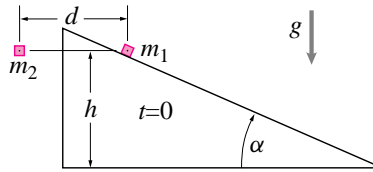

problem 6.53:

(Filename: ch8.7)

6.54 Block sliding on a ramp with friction. A square box is sliding down a ramp of angle θ with instantaneous velocity $v\hat{i}'$. It is assumed to not tip over.

- What is the force on the block from the ramp at point A? Answer in terms of any or all of $\theta, \ell, m, g, \mu, v, \hat{i}'$, and \hat{j}' . As a check, your answer should reduce to $\frac{mg}{2}\hat{j}'$ when $\theta = \mu = 0$. *
- In addition to solving the problem by hand, see if you can write a set of computer commands that, if θ, μ, ℓ, m, v and g were specified, would give the correct answer.
- Assuming $\theta = 80^\circ$ and $\mu = 0.9$, can the box slide this way or would it tip over? Why? *

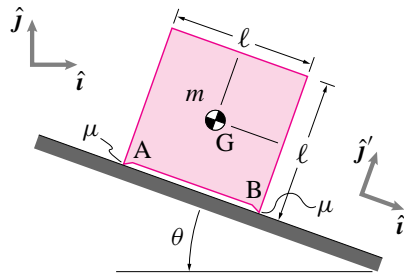

problem 6.54:

(Filename: pfigure3.f95p1p1)

6.55 A coin is given a sliding shove up a ramp with angle ϕ with the horizontal. It takes twice as long to slide down as it does to slide up. What is the coefficient of friction μ between the coin and the ramp. Answer in terms of some or all of m, g, ϕ and the initial sliding velocity v .

6.56 A skidding car. What is the braking acceleration of the front-wheel braked car as it slides down hill. Express your answer as a function of any or all of the following variables: the slope θ of the hill, the mass of the car m , the wheel base ℓ , and the gravitational constant g . Use $\mu = 1$. *

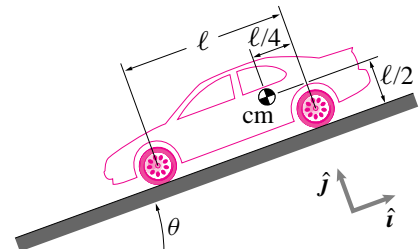

problem 6.56: A car skidding downhill on a slope of angle θ

(Filename: pfigure3.car)

6.57 Two blocks A and B are pushed up a frictionless inclined plane by an external force F as shown in the figure. The coefficient of friction between the two blocks is $\mu = 0.2$. The masses of the two blocks are $m_A = 5$ kg and $m_B = 2$ kg. Find the magnitude of the maximum allowable force such that no relative slip occurs between the two blocks.

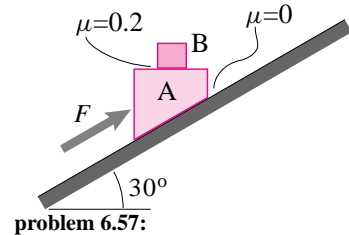

problem 6.57:

(Filename: summer95f.1)

6.58 A bead slides on a frictionless rod. The spring has constant k and rest length ℓ_0 . The bead has mass m .

- Given x and \dot{x} find the acceleration of the bead (in terms of some or all of $D, \ell_0, x, \dot{x}, m, k$ and any base vectors that you define).
- If the bead is allowed to move, as constrained by the slippery rod and the spring, find a differential equation that must be satisfied by the variable x . (Do not try to solve this somewhat ugly nonlinear equation.)
- In the special case that $\ell_0 = 0$ find how long it takes for the block to return to its starting position after release with no initial velocity at $x = x_0$.

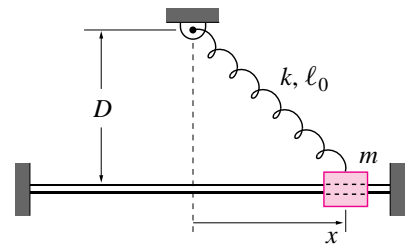

problem 6.58:

(Filename: p.s96.p1.2)

6.59 A bead oscillates on a straight frictionless wire. The spring obeys the equation $F = k(\ell - \ell_0)$, where ℓ = length of the spring and ℓ_0 is the 'rest' length. Assume

$$x(t=0) = x_0, \quad \dot{x}(t=0) = 0.$$

- a) Write a differential equation satisfied by $x(t)$.
- b) What is \dot{x} when $x = 0$? [hint: Don't try to solve the equation in (a)!]
- c) Note the simplification in (a) if $\ell_o = 0$ (spring is then a so-called "zero-length" spring).
- d) For this special case ($\ell_o = 0$) solve the equation in (a) and show the result agrees with (b) in this special case.

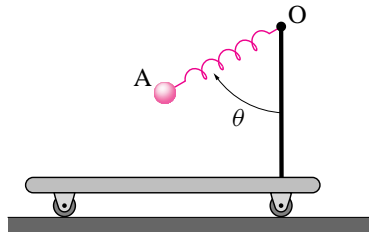

problem 6.61:

(Filename:DaneF94s3q6)

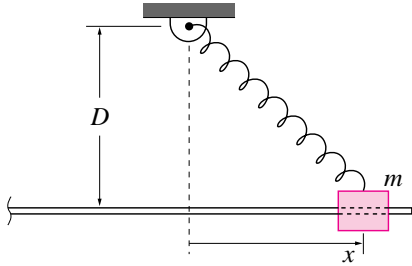

problem 6.59:

(Filename:pffigure.blue.60.1)

6.60 A cart on a springy leash. A cart B (mass m) rolls on a frictionless level floor. One end of an inextensible string is attached to the cart. The string wraps around a pulley at point A and the other end is attached to a spring with constant k . When the cart is at point O , it is in static equilibrium. The spring and room height are such that the spring would be relaxed if the end of the cart B was in the air at the ceiling pulley, point A . The ceiling height is h . The gravitational constant is g . The cart is pulled a horizontal distance d from the center of the room (at O) and released.

- a) Assuming that the cart never leaves the floor, what is the speed of the cart when it passes through the center of the room, in terms of m, h, g and d . *
- b) Does the cart undergo simple harmonic motion for small or large oscillations (specify which if either)? (Simple harmonic motion is when position is sine-wave and/or cosine-wave function of time.) *

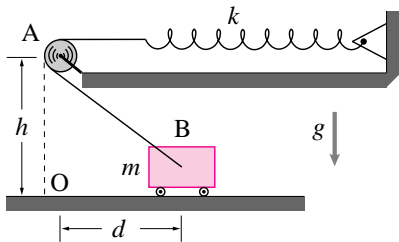

problem 6.60:

(Filename:cartosc)

6.61 The cart moves to the right with constant acceleration a . The ball has mass m . The spring has unstretched length ℓ_o and spring constant k . Assuming the ball is stationary with respect to the cart find the distance from O to A in terms of k, ℓ_o , and a . [Hint: find θ first.]

6.62 Consider a person, modeled as a rigid body, riding an accelerating motorcycle (2-D). The motorcycle is accelerating. The person is a rigid body. The person is sitting on the seat and cannot slide fore or aft, but is free to rock in the plane of the motorcycle (as if there is a hinge connecting the motorcycle to the rider at the seat). The person's feet are off the pegs and the legs are sticking down and not touching anything. The person's arms are like cables (they are massless and only carry tension). Assume all dimensions and masses are known (you have to define them carefully with a sketch and words). Assume the forward acceleration of the motorcycle is known. You may use numbers and/or variables to describe the quantities of interest.

- a) Draw a clear sketch of the problem showing needed dimension information and the coordinate system you will use.
- b) Draw a Free Body Diagram of the rider.
- c) Write the equations of linear and angular momentum balance for the rider.
- d) Find all forces on the rider from the motorcycle (i.e., at the hands and the seat).
- e) What are the forces on the motorcycle from the rider?

6.63 Acceleration of a bicycle on level ground. 2-D . A very compact bicyclist (modeled as a point mass M at the bicycle seat C with height h , and distance b behind the front wheel contact), rides a very light old-fashioned bicycle (all components have negligible mass) that is well maintained (all bearings have no frictional torque) and streamlined (neglect air resistance). The rider applies a force F_p to the pedal perpendicular to the pedal crank (with length L_c). No force is applied to the other pedal. The radius of the front wheel is R_f .

- a) Assuming no slip, what is the forward acceleration of the bicycle? [Hint: draw a FBD of the front wheel and crank, and another FBD of the whole bicycle-rider system.] *
- b) (Harder) Assuming the rider can push arbitrarily hard but that $\mu = 1$, what is the maximum possible forward acceleration of the bicycle. *

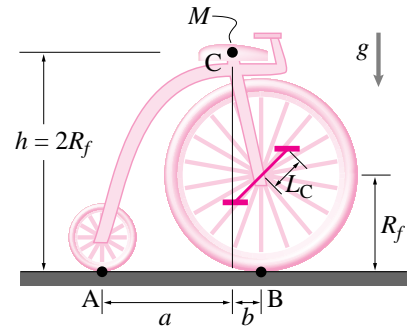

problem 6.63:

(Filename:f.3)

6.64 A 320 lbm mass is attached at the corner C of a light rigid piece of pipe bent as shown. The pipe is supported by ball-and-socket joints at A and D and by cable EF . The points A, D , and E are fastened to the floor and vertical sidewall of a pick-up truck which is accelerating in the z -direction. The acceleration of the truck is $\vec{a} = 5 \text{ ft/s}^2 \hat{k}$. There is gravity. Find the tension in cable EF . *

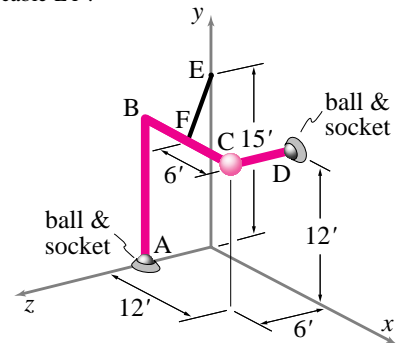

problem 6.64:

(Filename:mikef91p1)

6.65 A 5 ft by 8 ft rectangular plate of uniform density has mass $m = 10 \text{ lbm}$ and is supported by a ball-and-socket joint at point A and the light rods CE, BD , and GH . The entire system is attached to a truck which is moving with acceleration \vec{a}_T . The plate is moving without rotation or angular acceleration relative to the truck. Thus, the center of mass acceleration of the plate is the same as the truck's. Dimensions are as shown. Points A, C , and D are fixed to the truck but the truck is not touching the plate at any other points. Find the tension in rod BD .

- a) If the truck's acceleration is $\vec{a}_{cm} = (5 \text{ ft/s}^2) \hat{k}$, what is the tension or compression in rod BD ? *
- b) If the truck's acceleration is $\vec{a}_{cm} = (5 \text{ ft/s}^2) \hat{j} + (6 \text{ ft/s}^2) \hat{k}$, what is the tension or compression in rod GH ? *

c) A free body diagram of one wing is shown. The mass of one wing is m_w . What, in terms of m_{tot} , m_w , F_L , F_D , g , a, b, c , and ℓ are the reactions at the base of the wing (where it is attached to the plane), $\vec{F} = F_x\hat{i} + F_y\hat{j} + F_z\hat{k}$ and $\vec{M} = M_x\hat{i} + M_y\hat{j} + M_z\hat{k}$? *

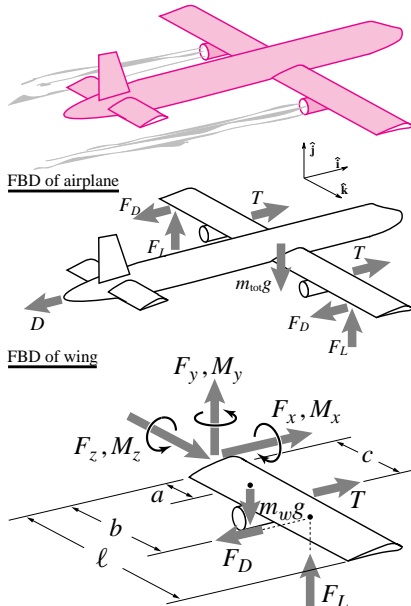

problem 6.71: An airplane in flight, a free body diagram of the plane, and a free body diagram of one wing

(Filename:pfigure3.airplane)

6.72 A rear-wheel drive car on level ground. The two left wheels are on perfectly slippery ice. The right wheels are on dry pavement. The negligible-mass front right wheel at B is steered straight ahead and rolls without slip. The right rear wheel at C also rolls without slip and drives the car forward with velocity $\vec{v} = v\hat{j}$ and acceleration $\vec{a} = a\hat{j}$. Dimensions are as shown and the car has mass m . What is the sideways force from the ground on the front wheel at B ? Answer in terms of any or all of m, g, a, b, ℓ, w , and \hat{i} . *

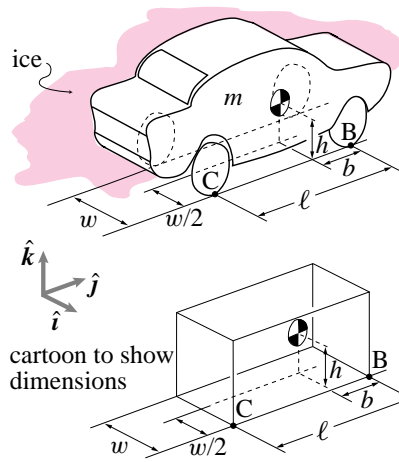

problem 6.72:

(Filename:pfigure3.f95p1p3)

6.73 A somewhat crippled car slams on the brakes. The suspension springs at A, B , and C are frozen and keep the car level and at constant height. The normal force at D is kept equal to N_D by the only working suspension spring which is on the left rear wheel at D . The only brake which is working is that of the right rear wheel at C which slides on the ground with friction coefficient μ . Wheels A, B , and D roll freely without slip. Dimensions are as shown.

- Find the acceleration of the car in terms of some or all of $m, w, \ell, b, h, g, \mu, \hat{j}$, and N_D .
- From the information given could you also find all of the reaction forces at all of the wheels? If so, why? If not, what can't you find and why? (No credit for correct answer. Credit depends on clear explanation.)

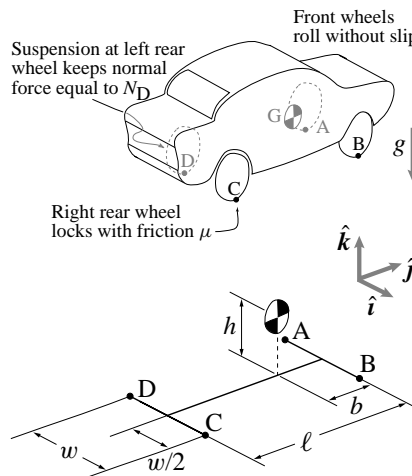

problem 6.73:

(Filename:s97p2.3)

6.74 Speeding tricycle gets a branch caught in the right rear wheel. A scared-stiff tricyclist riding on level ground gets a branch stuck in the right rear wheel so the wheel skids with friction coefficient μ . Assume that the center of mass of the tricycle-person system is directly

above the rear axle. Assume that the left rear wheel and the front wheel have negligible mass, good bearings, and have sufficient friction that they roll in the \hat{j} direction without slip, thus constraining the overall motion of the tricycle. Dimensions are shown in the lower sketch. Find the acceleration of the tricycle (in terms of some or all of $\ell, h, b, m, [I^m], \mu, g, \hat{i}, \hat{j}$, and \hat{k}). [Hint: check your answer against special cases for which you might guess the answer, such as when $\mu = 0$ or when $h = 0$.]

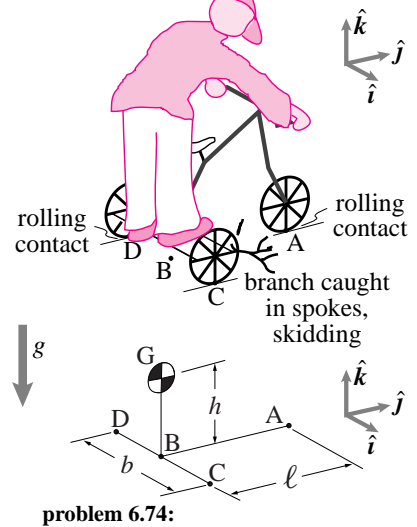

problem 6.74:

(Filename:p.f96.f.1)

Problems for Chapter 7

7.1 Kinematics of a particle in circular motion

skills

7.1 If a particle moves along a circle at constant rate (constant $\dot{\theta}$) following the equation

$$\vec{r}(t) = R \cos(\dot{\theta}t)\hat{i} + R \sin(\dot{\theta}t)\hat{j}$$

which of these things are true and why? If not true, explain why.

- (a) $\vec{v} = \vec{0}$
- (b) $\vec{v} = \text{constant}$
- (c) $|\vec{v}| = \text{constant}$
- (d) $\vec{a} = \vec{0}$
- (e) $\vec{a} = \text{constant}$
- (f) $|\vec{a}| = \text{constant}$
- (g) $\vec{v} \perp \vec{a}$

7.2 The motion of a particle is described by the following equations:

$$\begin{aligned} x(t) &= 1 \text{ m} \cdot \cos((5 \text{ rad/s}) \cdot t), \\ y(t) &= 1 \text{ m} \cdot \sin((5 \text{ rad/s}) \cdot t). \end{aligned}$$

- a) Show that the speed of the particle is constant.
- b) There are two points marked on the path of the particle: P with coordinates (0, 1 m) and Q with coordinates (1 m, 0). How much time does the particle take to go from P to Q?
- c) What is the acceleration of the particle at point Q?

7.3 Find a planar motion of a particle where the velocity and acceleration are always orthogonal. *

7.4 A bead goes around a circular track of radius 1 ft at a constant speed. It makes around the track in exactly 1 s.

- a) Find the speed of the bead.
- b) Find the magnitude of acceleration of the bead.

7.5 A 200 mm diameter gear rotates at a constant speed of 100 rpm.

- a) What is the speed of a peripheral point on the gear?
- b) If no point on the gear is to exceed the centripetal acceleration of 25 m/s^2 , find the maximum allowable angular speed (in rpm) of the gear.

7.6 A particle executes circular motion in the xy -plane at a constant angular speed $\dot{\theta} = 2 \text{ rad/s}$. The radius of the circular path is 0.5 m. The particle's motion is tracked from the instant when $\theta = 0$, i.e., at $t = 0$, $\theta = 0$. Find the velocity and acceleration of the particle at

- a) $t = 0.5 \text{ s}$ and
- b) $t = 15 \text{ s}$.

Draw the path and show the position of the particle at each instant.

7.7 A particle undergoes constant rate circular motion in the xy -plane. At some instant t_0 , its velocity is $v(t_0) = -3 \text{ m/s}\hat{i} + 4 \text{ m/s}\hat{j}$ and after 5 s the velocity is $v(t_0 + 5 \text{ s}) = 5/\sqrt{2} \text{ m/s}(\hat{i} + \hat{j})$. If the particle has not yet completed one revolution between the two instants, find

- a) the angular speed of the particle,
- b) the distance traveled by the particle in 5 s, and
- c) the acceleration of the particle at the two instants.

7.8 See also problem 7.9. A bead on a circular path of radius R in the xy -plane has rate of change of angular speed $\alpha = bt^2$. The bead starts from rest at $\theta = 0$.

- a) What is the bead's angular position θ (measured from the positive x -axis) and angular speed ω as a function of time?
- b) What is the angular speed as function of angular position?

7.9 Reconsider the bead from problem 7.8. This time, it has rate of change of angular speed proportional to angular position rather than time, $\alpha = c\theta^3/2$. The bead starts from rest at $\theta = 0$. What is the angular position and speed of the bead as a function of time? [Hint: this problem has 2 answers! (one of which you can find with a quick guess.)]

7.10 Repeat problem 7.51 but assume that the moment of interest is at position B with $\theta = 60^\circ$.

7.11 Solve $\dot{\omega} = \alpha$, given $\omega(0) = \omega_0$ and α is a constant.

7.12 Solve $\ddot{\theta} = \alpha$, given $\theta(0) = \theta_0$, $\dot{\theta}(0) = \dot{\theta}_0$, and α a constant.

7.13 Given $\dot{\omega} = \frac{d\dot{\theta}}{dt} = \alpha$ (a constant), find an expression for ω as a function of θ if $\omega(\theta = 0) = \omega_0$.

7.14 Given that $\ddot{\theta} - \lambda^2\theta = 0$, $\theta(0) = \pi/2$, and $\dot{\theta}(0) = 0$, find the value of θ at $t = 1 \text{ s}$.

7.15 Two runners run on a circular track side-by-side at the same constant angular rate ω about the center of the track. The inside runner is in a lane of radius r_i and the outside runner

is in a lane of radius r_o . What is the velocity of the outside runner relative to the inside runner in polar coordinates?

7.16 A particle oscillates on the arc of a circle with radius R according to the equation $\theta = \theta_0 \cos(\lambda t)$. What are the conditions on R , θ_0 , and λ so that the maximum acceleration in this motion occurs at $\theta = 0$. "Acceleration" here means the magnitude of the acceleration vector.

7.2 Dynamics of a particle in circular motion

skills

7.17 Force on a person standing on the equator. The total force acting on an object of mass m , moving with a constant angular speed ω on a circular path with radius r , is given by $F = m\omega^2 r$. Find the magnitude of the total force acting on a 150 lbf person standing on the equator. Neglect the motion of the earth around the sun and of the sun around the solar system, etc. The radius of the earth is 3963 mi. Give your solution in both pounds (lbf) and Newtons (N). *

7.18 The sum of forces acting on a mass $m = 10 \text{ lbf}$ is $\vec{F} = 100 \text{ lbf}\hat{i} - 120 \text{ lbf}\hat{j}$. The particle is going in circles at constant rate with $r = 18 \text{ in}$ and $\hat{e}_r = \cos 30^\circ\hat{i} + \sin 30^\circ\hat{j}$. Using $\sum \vec{F} = m\vec{a}$, find v .

7.19 The acceleration of a particle in planar circular motion is given by $\vec{a} = \alpha r \hat{e}_\theta - \omega^2 r \hat{e}_r$, where α is the angular acceleration, ω is the angular speed and r is the radius of the circular path. Using $\sum \vec{F} = m\vec{a}$, find the expressions for $\sum F_x$ and $\sum F_y$ in terms of α , ω , r , and θ , given that $\hat{e}_r = \cos \theta \hat{i} + \sin \theta \hat{j}$ and $\hat{e}_\theta = -\sin \theta \hat{i} + \cos \theta \hat{j}$.

7.20 Consider a particle with mass m in circular motion. Let $\ddot{\theta} = \alpha$, $\dot{\theta} = \omega$, and $\vec{r} = -r\hat{i}$. Let $\sum \vec{F} = \sum F_r \hat{e}_r + \sum F_\theta \hat{e}_\theta$, where $\hat{e}_r = -\hat{i}$ and $\hat{e}_\theta = \hat{k}$. Using $\sum \vec{F} = m\vec{a}$, express $\sum F_r$ and $\sum F_\theta$ in terms of α , ω , r , and m .

7.21 A bead of mass m on a circular path of radius R in the xy -plane has rate of change of angular speed $\alpha = ct^3$. The bead starts from rest at $\theta = 0$.

- a) What is the angular momentum of the bead about the origin at $t = t_1$?
- b) What is the kinetic energy of the bead at $t = t_1$.

7.22 A 200 gm particle goes in circles about a fixed center at a constant speed $v = 1.5$ m/s. It takes 7.5 s to go around the circle once.

- Find the angular speed of the particle.
- Find the magnitude of acceleration of the particle.
- Take center of the circle to be the origin of a xy -coordinate system. Find the net force on the particle when it is at $\theta = 30^\circ$ from the x -axis.

7.23 A race car cruises on a circular track at a constant speed of 120 mph. It goes around the track once in three minutes. Find the magnitude of the centripetal force on the car. What applies this force on the car? Does the driver have any control over this force?

7.24 A particle moves on a counter-clockwise, origin-centered circular path in the xy -plane at a constant rate. The radius of the circle is r , the mass of the particle is m , and the particle completes one revolution in time τ .

- Neatly draw the following things:
 - The path of the particle.
 - A dot on the path when the particle is at $\theta = 0^\circ, 90^\circ,$ and 210° , where θ is measured from the x -axis (positive counter-clockwise).
 - Arrows representing $\hat{e}_R, \hat{e}_\theta, \vec{v}$, and \vec{a} at each of these points.
- Calculate all of the quantities in part (3) above at the points defined in part (2), (represent vector quantities in terms of the cartesian base vectors \hat{i} and \hat{j}). *
- If this motion was imposed by the tension in a string, what would that tension be? *
- Is radial tension enough to maintain this motion or is another force needed to keep the motion going (assuming no friction)? *
- Again, if this motion was imposed by the tension in a string, what is F_x , the x component of the force in the string, when $\theta = 210^\circ$? Ignore gravity.

7.25 The velocity and acceleration of a 1 kg particle, undergoing constant rate circular motion, are known at some instant t :

$$\vec{v} = -10 \text{ m/s}(\hat{i} + \hat{j}), \quad \vec{a} = 2 \text{ m/s}^2(\hat{i} - \hat{j}).$$

- Write the position of the particle at time t using \hat{e}_R and \hat{e}_θ base vectors.
- Find the net force on the particle at time t .
- At some later time t^* , the net force on the particle is in the $-\hat{j}$ direction. Find the elapsed time $t - t^*$.
- After how much time does the force on the particle reverse its direction.

7.26 A particle of mass 3 kg moves in the xy -plane so that its position is given by

$$\mathbf{r}(t) = 4 \text{ m}[\cos(\frac{2\pi t}{s})\hat{i} + \sin(\frac{2\pi t}{s})\hat{j}].$$

- What is the path of the particle? Show how you know what the path is.
- What is the angular velocity of the particle? Is it constant? Show how you know if it is constant or not.
- What is the velocity of the particle in polar coordinates?
- What is the speed of the particle at $t = 3$ s?
- What net force does it exert on its surroundings at $t = 0$ s? Assume the x and y axis are attached to a Newtonian frame.
- What is the angular momentum of the particle at $t = 3$ s about point O located at the origin of the coordinate system that the particle is referenced to?

7.27 Going in circles — a comparison of constant and nonconstant rate motion. A 100 gm mass is going in circles of radius $R = 20$ cm at a constant rate $\dot{\theta} = 3$ rad/s. Another identical mass is going in circles of the same radius but at a non-constant rate. The second mass is accelerating at $\ddot{\theta} = 2$ rad/s² and at position A, it happens to have the same angular speed as the first mass.

- Find and draw the accelerations of the two masses (call them I and II) at position A.
- Find \vec{H}_O for both masses at position A. *
- Find \vec{H}_O for both masses at positions A and B. Do the changes in \vec{H}_O between the two positions reflect (qualitatively) the results obtained in (b)? *
- If the masses are pinned to the center O by massless rigid rods, is tension in the rods enough to keep the two motions going? Explain.

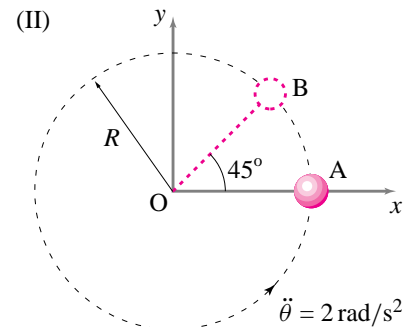
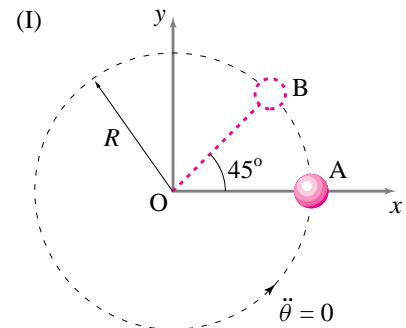

problem 7.27:

(Filename: pfigure.s94h8p2)

7.28 A small mass m is connected to one end of a spring. The other end of the spring is fixed to the center of a circular track. The radius of the track is R , the unstretched length of the spring is $l_0 (< R)$, and the spring constant is k .

- With what speed should the mass be launched in the track so that it keeps going at a constant speed?
- If the spring is replaced by another spring of same relaxed length but twice the stiffness, what will be the new required launch speed of the particle?

7.29 A bead of mass m is attached to a spring with constant k . The bead slides without friction in the tube shown. The tube is driven at a constant angular rate ω_0 about axis AA' by a motor (not pictured). There is no gravity. The unstretched spring length is r_0 . Find the radial position r of the bead if it is stationary with respect to the rotating tube. *

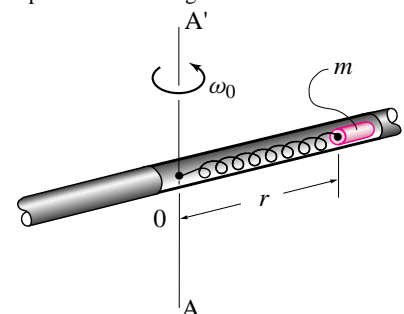

problem 7.29:

(Filename: Dane94s2q6)

7.30 A particle of mass m is restrained by a string to move with a constant angular speed ω around a circle of radius R on a horizontal frictionless table. If the radius of the circle is reduced to r , by pulling the string with a force F through a hole in the table, what will the particle's angular velocity be? Is kinetic energy is conserved? Why or why not?

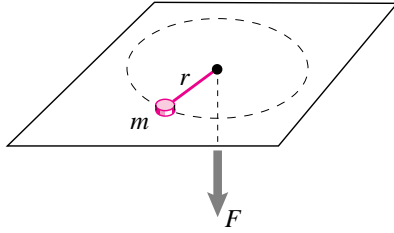

problem 7.30:

(Filename:pfimage.blue.44.1)

7.31 An 'L' shaped rigid, massless, and frictionless bar is made up of two uniform segments of length $\ell = 0.4$ m each. A collar of mass $m = 0.5$ kg, attached to a spring at one end, slides frictionlessly on one of the arms of the 'L'. The spring is fixed to the elbow of the 'L' and has a spring constant $k = 6$ N/m. The structure rotates clockwise at a constant rate $\omega = 2$ rad/s. If the collar is steady at a distance $\frac{3}{4}\ell = 0.3$ m away from the elbow of the 'L', find the relaxed length of the spring, ℓ_0 . *

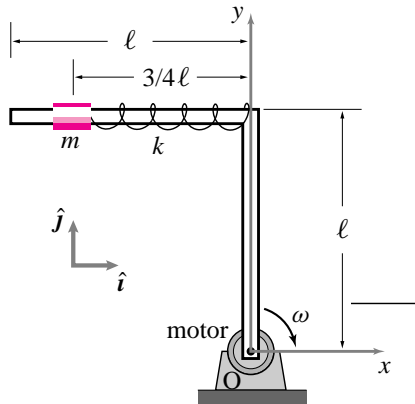

problem 7.31: Forces in constant rate circular motion.

(Filename:pfimage.Lbar)

7.32 A massless rigid rod with length ℓ attached to a ball of mass M spins at a constant angular rate ω which is maintained by a motor (not shown) at the hinge point. The rod can only withstand a tension of T_{cr} before breaking. Find the maximum angular speed of the ball so that the rod does not break assuming

- there is no gravity, and
- there is gravity (neglect bending stresses).

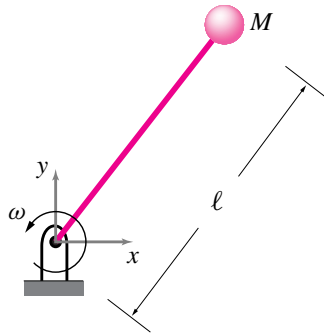

problem 7.32:

(Filename:Danf94s2q5)

7.33 A 1 m long massless string has a particle of 10 grams mass at one end and is tied to a stationary point O at the other end. The particle rotates counter-clockwise in circles on a frictionless horizontal plane. The rotation rate is 2π rev/sec. Assume an xy -coordinate system in the plane with its origin at O .

- Make a clear sketch of the system.
- What is the tension in the string (in Newtons)? *
- What is the angular momentum of the mass about O ? *
- When the string makes a 45° angle with the positive x and y axis on the plane, the string is quickly and cleanly cut. What is the position of the mass 1 sec later? Make a sketch. *

7.34 A ball of mass M fixed to an inextensible rod of length ℓ and negligible mass rotates about a frictionless hinge as shown in the figure. A motor (not shown) at the hinge point accelerates the mass-rod system from rest by applying a constant torque M_O . The rod is initially lined up with the positive x -axis. The rod can only withstand a tension of T_{cr} before breaking. At what time will the rod break and after how many revolutions? Include gravity if you like.

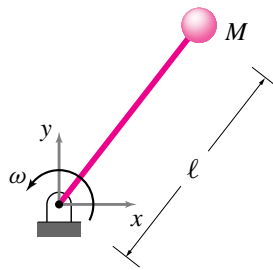

problem 7.34:

(Filename:pfimage5.mike.sum95)

7.35 A particle of mass m , tied to one end of a rod whose other end is fixed at point O to a motor, moves in a circular path in the vertical plane at a constant rate. Gravity acts in the $-\hat{j}$ direction.

- Find the difference between the maximum and minimum tension in the rod. *

b) Find the ratio $\frac{\Delta T}{T_{max}}$ where $\Delta T = T_{max} - T_{min}$. A criterion for ignoring gravity might be if the variation in tension is less than 2% of the maximum tension; i.e., when $\frac{\Delta T}{T_{max}} < 0.02$. For a given length r of the rod, find the rotation rate ω for which this condition is met. *

c) For $\omega = 300$ rpm, what would be the length of the rod for the condition in part (b) to be satisfied? *

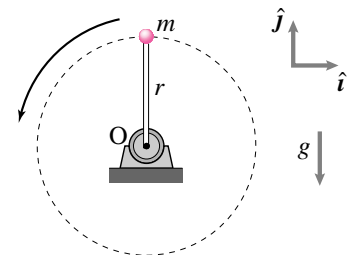

problem 7.35:

(Filename:pfimage4.rph)

7.36 A massless rigid bar of length L is hinged at the bottom. A force F is applied at point A at the end of the bar. A mass m is glued to the bar at point B, a distance d from the hinge. There is no gravity. What is the acceleration of point A at the instant shown? Assume the angular velocity is initially zero.

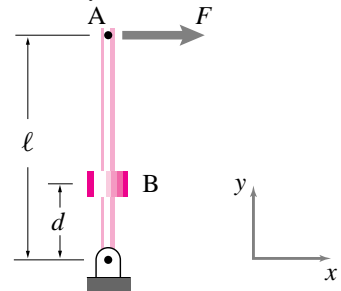

problem 7.36:

(Filename:pfimage.blue.10.1)

7.37 The mass m is attached rigidly to the rotating disk by the light rod AB of length ℓ . Neglect gravity. Find M_A (the moment on the rod AB from its support point at A) in terms of $\dot{\theta}$ and $\ddot{\theta}$. What is the sign of M_A if $\dot{\theta} = 0$ and $\ddot{\theta} > 0$? What is the sign if $\dot{\theta} = 0$ and $\ddot{\theta} < 0$?

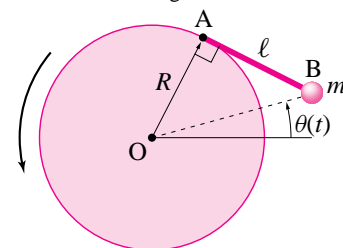

problem 7.37:

(Filename:pfimage.blue.84.2)

7.38 Pendula using energy methods. Find the equations of motion for the pendula in problem 7.94 using energy methods. *

7.39 Tension in a simple pendulum string. A simple pendulum of length 2 m with mass 3 kg is released from rest at an initial angle of 60° from the vertically down position.

- What is the tension in the string just after the pendulum is released?
- What is the tension in the string when the pendulum has reached 30° from the vertical?

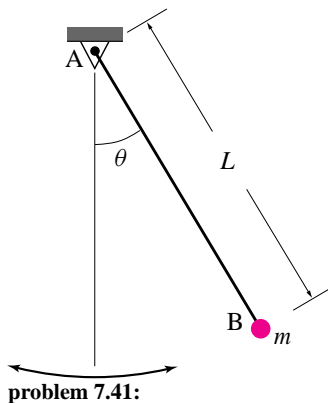

problem 7.41: (Filename: pfigure.s94h8p5)

7.40 Simply the simple pendulum. Find the nonlinear governing differential equation for a simple pendulum

$$\ddot{\theta} = -\frac{g}{l} \sin \theta$$

as many different ways as you can.

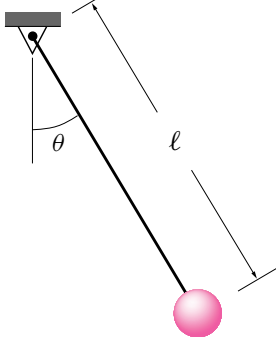

problem 7.40: A simple pendulum. (Filename: spend)

7.41 Tension in a rope-swing rope. Model a swinging person as a point mass. The swing starts from rest at an angle $\theta = 90^\circ$. When the rope passes through vertical the tension in the rope is higher (it is hard to hang on). A person wants to know ahead of time if she is strong enough to hold on. How hard does she have to hang on compared, say, to her own weight? You are to find the solution two ways. Use the same m , g , and L for both solutions.

- Find $\ddot{\theta}$ as a function of g , L , θ , and m . This equation is the governing differential equation. Write it as a system of first order equations. Solve them numerically. Once you know $\dot{\theta}$ at the time the rope is vertical you can use other mechanics relations to find the tension. If you like, you can plot the tension as a function of time as the mass falls.
- Use conservation of energy to find $\dot{\theta}$ at $\theta = 0$. Then use other mechanics relations to find the tension. *

7.42 Pendulum. A pendulum with a negligible-mass rod and point mass m is released from rest at the horizontal position $\theta = \pi/2$.

- Find the acceleration (a vector) of the mass just after it is released at $\theta = \pi/2$ in terms of l , m , g and any base vectors you define clearly.
- Find the acceleration (a vector) of the mass when the pendulum passes through the vertical at $\theta = 0$ in terms of l , m , g and any base vectors you define clearly
- Find the string tension when the pendulum passes through the vertical at $\theta = 0$ (in terms of l , m and g).

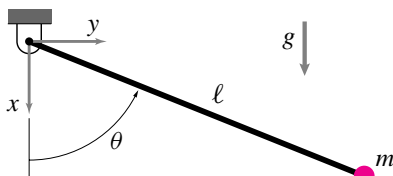

problem 7.42: (Filename: s97p2.1)

7.43 Simple pendulum, extended version. A point mass $M = 1$ kg hangs on a string of length $L = 1$ m. Gravity pulls down on the mass with force Mg , where $g = 10$ m/s². The pendulum lies in a vertical plane. At any time t , the angle between the pendulum and the straight-down position is $\theta(t)$. There is no air friction.

- Equation of motion.** Assuming that you know both θ and $\dot{\theta}$, find $\ddot{\theta}$. There are several ways to do this problem. Use any ways that please you. *
- Tension.** Assuming that you know θ and $\dot{\theta}$, find the tension T in the string.
- Reaction components.** Assuming you know θ and $\dot{\theta}$, find the x and y components of the force that the hinge support causes on the pendulum. Define your coordinate directions sensibly.

- Reduction to first order equations.** The equation that you found in (a) is a nonlinear second order ordinary differential equation. It can be changed to a pair of first order equations by defining a new variable $\alpha \equiv \dot{\theta}$. Write the equation from (a) as a pair of first order equations. Solving these equations is equivalent to solving the original second order equation. *
- Numerical solution.** Given the initial conditions $\theta(t = 0) = \pi/2$ and $\alpha(t = 0) = \dot{\theta}(t = 0) = 0$, one should be able to find what the position and speed of the pendulum is as a function of time. Using the results from (b) and (c) one can also find the reaction components. Using any computer and any method you like, find: $\theta(t)$, $\dot{\theta}(t)$ & $T(t)$. Make a single plot, or three vertically aligned plots, of these variables for one full oscillation of the pendulum.
- Maximum tension.** Using your numerical solutions, find the maximum value of the tension in the rod as the mass swings. *
- Period of oscillation.** How long does it take to make one oscillation?
- Other observations.** Make any observations that you think are interesting about this problem. Some questions: Does the solution to (f) depend on the length of the string? Is the solution to (f) exactly 30 or just a number near 30? How does the period found in (g) compare to the period found by solving the linear equation $\ddot{\theta} + (g/l)\theta = 0$, based on the (inappropriate-to-use in this case) small angle approximation $\sin \theta = \theta$?

7.44 Bead on a hoop with friction. A bead slides on a rigid, stationary, circular wire. The coefficient of friction between the bead and the wire is μ . The bead is loose on the wire (not a tight fit but not so loose that you have to worry about rattling). Assume gravity is negligible.

- Given v , m , R , & μ ; what is \dot{v} ? *
- If $v(\theta = 0) = v_0$, how does v depend on θ , μ , v_0 and m ? *

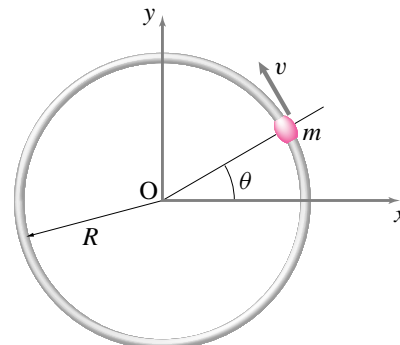

problem 7.44: (Filename: pfigure.s94h10p1)

7.45 Particle in a chute. One of a million non-interacting rice grains is sliding in a circular chute with radius R . Its mass is m and it slides with coefficient of friction μ (Actually it slides, rolls and tumbles — μ is just the effective coefficient of friction from all of these interactions.) Gravity g acts downwards.

- Find a differential equation that is satisfied by θ that governs the speed of the rice as it slides down the hoop. Parameters in this equation can be m , g , R and μ [Hint: Draw FBD, write eqs of mechanics, express as ODE.]
- Find the particle speed at the bottom of the chute if $R = .5m$, $m = .1$ grams, $g = 10 \text{ m/s}^2$, and $\mu = .2$ as well as the initial values of $\theta_0 = 0$ and its initial downward speed is $v_0 = 10 \text{ m/s}$. [Hint: you are probably best off seeking a numerical solution.]

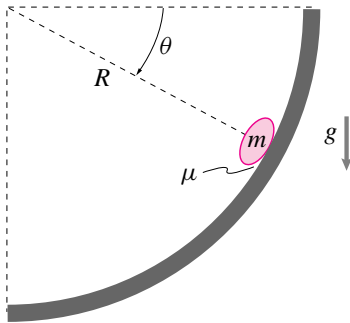

problem 7.45: (Filename:p.f96.p3.1)

7.46 Due to a push which happened in the past, the collar with mass m is sliding up at speed v_0 on the circular ring when it passes through the point A. The ring is frictionless. A spring of constant k and unstretched length R is also pulling on the collar.

- What is the acceleration of the collar at A. Solve in terms of R , v_0 , m , k , g and any base vectors you define.
- What is the force on the collar from the ring when it passes point A? Solve in terms of R , v_0 , m , k , g and any base vectors you define.

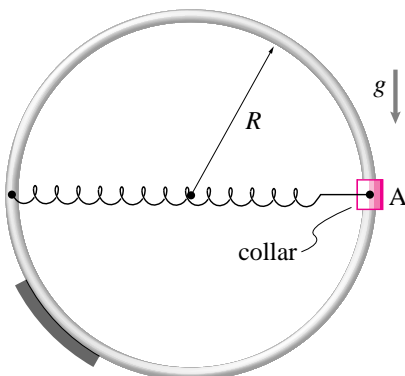

problem 7.46: (Filename:s93q4Ruina)

7.47 A toy used to shoot pellets is made out of a thin tube which has a spring of spring constant k on one end. The spring is placed in a straight section of length ℓ ; it is unstretched when its length is ℓ . The straight part is attached to a (quarter) circular tube of radius R , which points up in the air.

- A pellet of mass m is placed in the device and the spring is pulled to the left by an amount $\Delta \ell$. Ignoring friction along the travel path, what is the pellet's velocity \vec{v} as it leaves the tube? *
- What force acts on the pellet just prior to its departure from the tube? What about just after? *

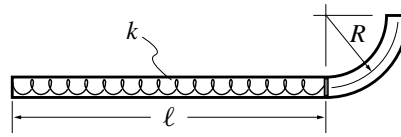

problem 7.47: (Filename:pfigure.blue.toygun)

7.48 A block with mass m is moving to the right at speed v_0 when it reaches a circular frictionless portion of the ramp.

- What is the speed of the block when it reaches point B? Solve in terms of R , v_0 , m and g .
- What is the force on the block from the ramp just after it gets onto the ramp at point A? Solve in terms of R , v_0 , m and g . Remember, force is a vector.

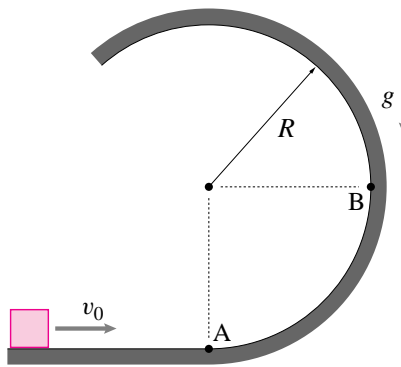

problem 7.48: (Filename:s93q4Sachse)

7.49 A car moves with speed v along the surface of the hill shown which can be approximated as a circle of radius R . The car starts at a point on the hill at point O. Compute the magnitude of the speed v such that the car just leaves the ground at the top of the hill.

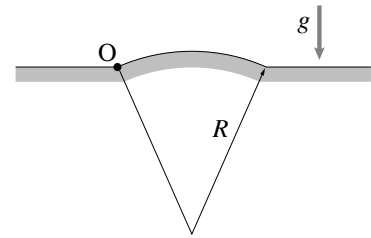

problem 7.49: (Filename:pfigure.blue.65.1)

7.3 Kinematics of a rigid body in planar circular motion

skills

7.50 Find $\vec{v} = \vec{\omega} \times \vec{r}$, if $\vec{\omega} = 1.5 \text{ rad/s} \hat{k}$ and $\vec{r} = 2 \text{ m} \hat{i} - 3 \text{ m} \hat{j}$.

7.51 A particle goes around a circle shown in the figure, at the moment of interest, with angular velocity $\vec{\omega} = 5 \text{ rad/s} \hat{k}$ and angular acceleration $\vec{\alpha} = 2 \text{ rad/s}^2 \hat{k}$. Find, draw, and label the tangential and normal acceleration

- of the particle at the location A. *
- of the particle at the location B.

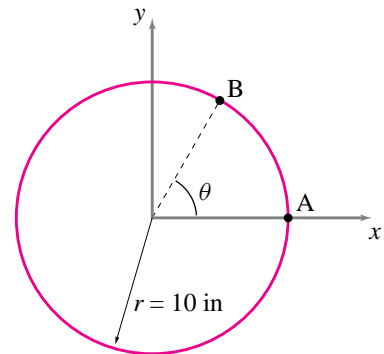

problem 7.51: (Filename:efig1.2.18)

7.52 A motor turns a uniform disc of radius R counter-clockwise about its mass center at a constant rate ω . The disc lies in the xy -plane and its angular displacement θ is measured (positive counter-clockwise) from the x -axis. What is the angular displacement $\theta(t)$ of the disc if it starts at $\theta(0) = \theta_0$ and $\dot{\theta}(0) = \omega$? What are the velocity and acceleration of a point P at position $\vec{r} = x \hat{i} + y \hat{j}$?

7.53 A disc is rotating at 15 rpm. How many seconds does it take to rotate by 180 degrees? What is the angular speed of the disc in rad/s?

7.54 Two discs \mathcal{A} and \mathcal{B} rotate at constant speeds about their centers. Disc \mathcal{A} rotates at 100 rpm and disc \mathcal{B} rotates at 10 rad/s. Which is rotating faster?

7.55 Find the angular velocities of the second, minute, and hour hands of a clock.

7.56 A motor turns a uniform disc of radius R counter-clockwise about its mass center at a constant rate ω . The disc lies in the xy -plane and its angular displacement θ is measured (positive counter-clockwise) from the x -axis. What are the velocity and acceleration of a point P at position $\vec{r}_P = c\hat{i} + d\hat{j}$ relative to the velocity and acceleration of a point Q at position $\vec{r}_Q = 0.5(-d\hat{i} + c\hat{j})$ on the disk? ($c^2 + d^2 < R^2$.)

7.57 A 0.4 m long rod AB has many holes along its length such that it can be pegged at any of the various locations. It rotates counter-clockwise at a constant angular speed about a peg whose location is not known. At some instant t , the velocity of end B is $\vec{v}_B = -3 \text{ m/s} \hat{j}$. After $\frac{\pi}{20}$ s, the velocity of end B is $\vec{v}_B = -3 \text{ m/s} \hat{i}$. If the rod has not completed one revolution during this period,

- find the angular velocity of the rod, and
- find the location of the peg along the length of the rod.

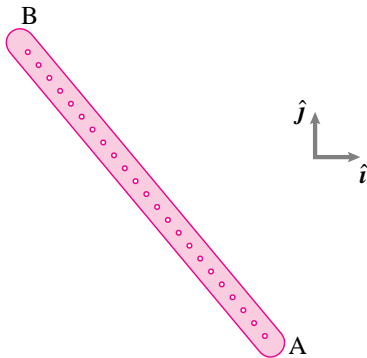

problem 7.57:

(Filename: pfigure4.3.rp9)

7.58 A circular disc of radius $r = 250$ mm rotates in the xy -plane about a point which is at a distance $d = 2r$ away from the center of the disk. At the instant of interest, the linear speed of the center C is 0.60 m/s and the magnitude of its centripetal acceleration is 0.72 m/s².

- Find the rotational speed of the disk.
- Is the given information enough to locate the center of rotation of the disk?
- If the acceleration of the center has no component in the \hat{j} direction at the moment of interest, can you locate the center of rotation? If yes, is the point you locate unique? If not, what other information is required to make the point unique?

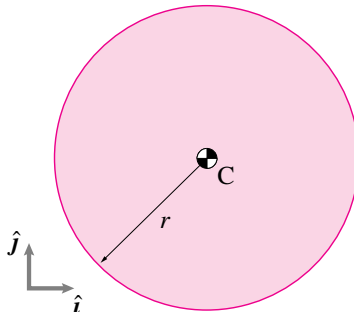

problem 7.58:

(Filename: pfigure4.3.rp8)

7.59 A disc \mathcal{C} spins at a constant rate of two revolutions per second counter-clockwise about its geometric center, G , which is fixed. A point P is marked on the disk at a radius of one meter. At the moment of interest, point P is on the x -axis of an xy -coordinate system centered at point G .

- Draw a neat diagram showing the disk, the particle, and the coordinate axes.
- What is the angular velocity of the disk, $\vec{\omega}_C$?
- What is the angular acceleration of the disk, $\vec{\alpha}_C$?
- What is the velocity \vec{v}_P of point P ?
- What is the acceleration \vec{a}_P of point P ?

7.60 A uniform disc of radius $r = 200$ mm is mounted eccentrically on a motor shaft at point O . The motor rotates the disc at a constant angular speed. At the instant shown, the velocity of the center of mass is $\vec{v}_G = -1.5 \text{ m/s} \hat{j}$.

- Find the angular velocity of the disc.
- Find the point with the highest linear speed on the disc. What is its velocity?

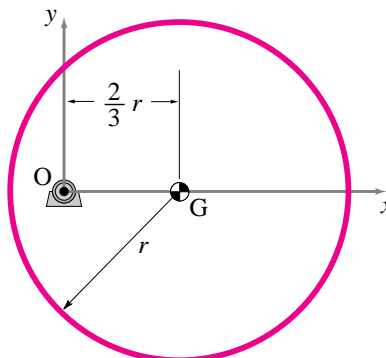

problem 7.60:

(Filename: pfigure4.3.rp4)

7.61 The circular disc of radius $R = 100$ mm rotates about its center O . At a given instant, point A on the disk has a velocity $v_A = 0.8$ m/s in the direction shown. At the same instant, the tangent of the angle θ made by the total acceleration vector of any point B with its radial line to O is 0.6 . Compute the angular acceleration α of the disc.

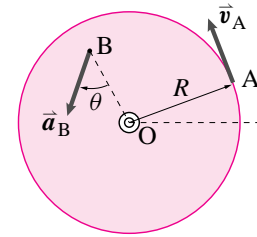

problem 7.61:

(Filename: pfigure.blue.43.2)

7.62 Show that, for non-constant rate circular motion, the acceleration of all points in a given radial line are parallel.

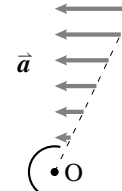

problem 7.62:

(Filename: pfigure.DH.5.1a)

7.63 A motor turns a uniform disc of radius R about its mass center at a variable angular rate ω with rate of change $\dot{\omega}$, counter-clockwise. The disc lies in the xy -plane and its angular displacement θ is measured from the x -axis, positive counter-clockwise. What are the velocity and acceleration of a point P at position $\vec{r}_P = c\hat{i} + d\hat{j}$ relative to the velocity and acceleration of a point Q at position $\vec{r}_Q = 0.5(-d\hat{i} + y\hat{j})$ on the disk? ($c^2 + d^2 < R^2$.)

7.64 Bit-stream kinematics of a CD. A Compact Disk (CD) has bits of data etched on concentric circular tracks. The data from a track is read by a beam of light from a head that is positioned under the track. The angular speed of the disk remains constant as long as the head is positioned over a particular track. As the head moves to the next track, the angular speed of the disk changes, so that the *linear speed* at any track is always the same. The data stream comes out at a constant rate 4.32×10^6 bits/second. When the head is positioned on the outermost track, for which $r = 56$ mm, the disk rotates at 200 rpm.

- What is the number of bits of data on the outermost track.
- find the angular speed of the disk when the head is on the innermost track ($r = 22$ mm), and
- find the numbers of bits on the innermost track.

7.65 A horizontal disk \mathcal{D} of diameter $d = 500$ mm is driven at a constant speed of 100 rpm. A small disk \mathcal{C} can be positioned anywhere between $r = 10$ mm and $r = 240$ mm on disk \mathcal{D} by sliding it along the overhead shaft and then fixing it at the desired position with a set screw (see the figure). Disk

C rolls without slip on disk D. The overhead shaft rotates with disk C and, therefore, its rotational speed can be varied by varying the position of disk C. This gear system is called *brush gearing*. Find the maximum and minimum rotational speeds of the overhead shaft. *

Side View

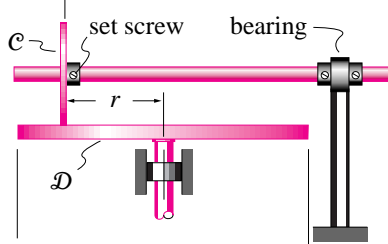

Top View

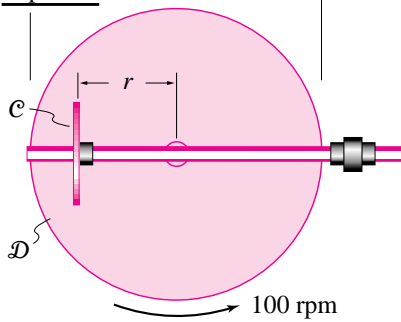

problem 7.65:

(Filename:pfigure4.rpc)

7.66 Two points A and B are on the same machine part that is hinged at an as yet unknown location C. Assume you are given that points at positions \vec{r}_A and \vec{r}_B are supposed to move in given directions, indicated by unit vectors as $\hat{\lambda}_A$ and $\hat{\lambda}_B$. For each of the parts below, illustrate your results with two numerical examples (in consistent units): i) $\vec{r}_A = 1\hat{i}$, $\vec{r}_B = 1\hat{j}$, $\hat{\lambda}_A = 1\hat{j}$, and $\hat{\lambda}_B = -1\hat{i}$ (thus $\vec{r}_C = \vec{0}$), and ii) a more complex example of your choosing.

- Describe in detail what equations must be satisfied by the point \vec{r}_C .
- Write a computer program that takes as input the 4 pairs of numbers $[\vec{r}_A]$, $[\vec{r}_B]$, $[\hat{\lambda}_A]$ and $[\hat{\lambda}_B]$ and gives as output the pair of numbers $[\hat{\lambda}_C]$.
- Find a formula of the form $\vec{r}_C = \dots$ that explicitly gives the position vector for point C in terms of the 4 given vectors.

7.4 Dynamics of a rigid body in planar circular motion

skills

7.67 The structure shown in the figure consists of two point masses connected by three rigid,

massless rods such that the whole structure behaves like a rigid body. The structure rotates counterclockwise at a constant rate of 60 rpm. At the instant shown, find the force in each rod.

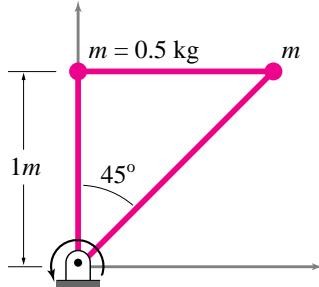

problem 7.67:

(Filename:pfig4.1.rp10)

7.68 The hinged disk of mass m (uniformly distributed) is acted upon by a force P shown in the figure. Determine the initial angular acceleration and the reaction forces at the pin O.

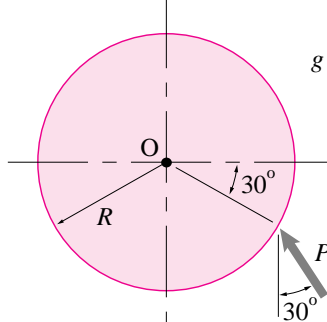

problem 7.68:

(Filename:pfigure.blue.41.3)

7.69 A thin uniform circular disc of mass M and radius R rotates in the xy plane about its center of mass point O. Driven by a motor, it has rate of change of angular speed proportional to angular position, $\alpha = d\theta^{5/2}$. The disc starts from rest at $\theta = 0$.

- What is the rate of change of angular momentum about the origin at $\theta = \frac{\pi}{3}$ rad?
- What is the torque of the motor at $\theta = \frac{\pi}{3}$ rad?
- What is the total kinetic energy of the disk at $\theta = \frac{\pi}{3}$ rad?

7.70 A uniform circular disc rotates at constant angular speed ω about the origin, which is also the center of the disc. Its radius is R. Its total mass is M.

- What is the total force and moment required to hold it in place (use the origin as the reference point of angular momentum and torque).
- What is the total kinetic energy of the disk?

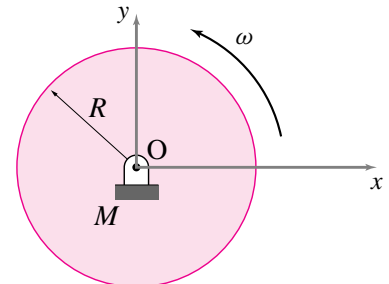

problem 7.70:

(Filename:pfigure.blue.87a.1)

7.71 Neglecting gravity, calculate $\alpha = \dot{\omega} = \ddot{\theta}$ at the instant shown for the system in the figure.

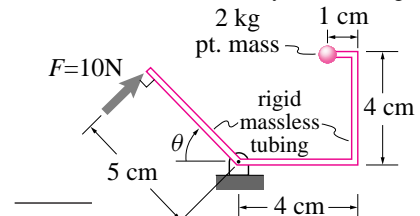

problem 7.71:

(Filename:pfigure.blue.20.1)

7.72 A disk of mass M and radius R is attached to an electric motor as shown. A coin of mass m rests on the disk, with the center of the coin a distance r from the center of the disk. Assume that $m \ll M$, and that the coefficient of friction between the coin and the disk is μ . The motor delivers a constant power P to the disk. The disk starts from rest when the motor is turned on at $t = 0$.

- What is the angular velocity of the disk as a function of time?
- What is its angular acceleration?
- At what time does the coin begin to slip off the disk? (It will suffice here to give the equation for t that must be solved.)

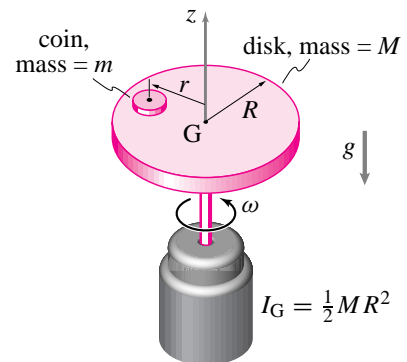

problem 7.72:

(Filename:pfigure.blue.45.1)

7.73 2-D constant rate gear train. The angular velocity of the input shaft (driven by a motor not shown) is a constant, $\omega_{input} = \omega_A$. What is the angular velocity $\omega_{output} = \omega_C$ of the output shaft and the speed of a point on the outer edge of disc C, in terms of R_A , R_B , R_C , and ω_A ?

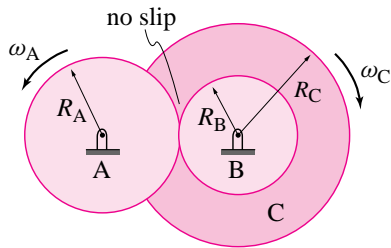

problem 7.73: A set of gears turning at constant rate.

(Filename:ch4.3)

7.74 2-D constant speed gear train. Gear A is connected to a motor(not shown) and gear B, which is welded to gear C, is connected to a taffy-pulling mechanism. Assume you know the torque $M_{input} = M_A$ and angular velocity $\omega_{input} = \omega_A$ of the input shaft. Assume the bearings and contacts are frictionless.

- What is the input power?
- What is the output power?
- What is the output torque $M_{output} = M_C$, the torque that gear C applies to its surroundings in the clockwise direction?

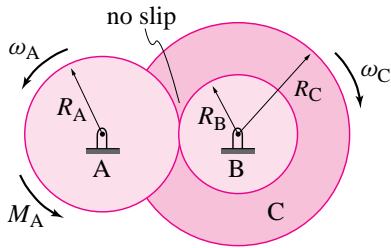

problem 7.74:

(Filename:pfigure.s94h6p5)

7.75 Accelerating rack and pinion. The two gears shown are welded together and spin on a frictionless bearing. The inner gear has radius 0.5 m and negligible mass. The outer disk has 1 m radius and a uniformly distributed mass of 0.2 kg. They are loaded as shown with the force $F = 20$ N on the massless frictionless rack. At the time of interest the angular velocity is $\omega = 2$ rad/s (though ω is not constant). The point P is on the disk a distance 1 m from the center. At the time of interest, point P is on the positive y axis.

- What is the speed of point P?
- What is the velocity of point P?
- What is the angular acceleration α of the gear?
- What is the acceleration of point P?
- What is the magnitude of the acceleration of point P?
- What is the rate of increase of the speed of point P?

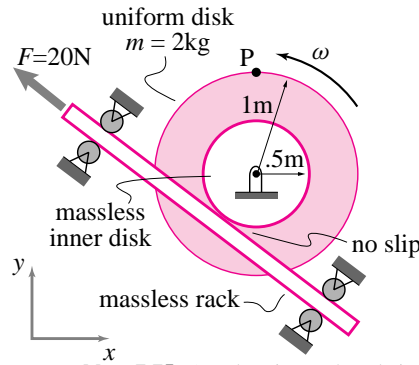

problem 7.75: Accelerating rack and pinion

(Filename:pg45.2)

7.76 A 2-D constant speed gear train. Shaft B is rigidly connected to gears G_4 and G_3 . G_3 meshes with gear G_6 . Gears G_6 and G_5 are both rigidly attached to shaft CD. Gear G_5 meshes with G_2 which is welded to shaft A. Shaft A and shaft B spin independently. The input torque $M_{input} = 500$ N·m and the spin rate $\omega_{input} = 150$ rev/min. Assume the bearings and contacts are frictionless.

- What is the input power? *
- What is the output power? *
- What is the angular velocity ω_{output} of the output shaft? *
- What is the output torque M_{output} ? *

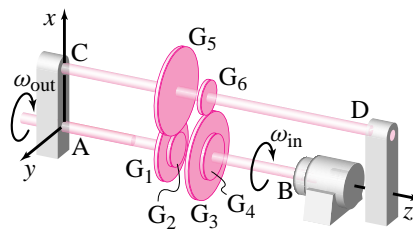

Front view

$$R_{G_5} = 3R_{G_2}$$

$$3R_{G_3} = 5R_{G_6}$$

problem 7.76:

(Filename:pfigure.s94h6p6)

7.77 Two gears rotating at constant rate. See also problems 4.16 and ???. At the input to a gear box a 100 lbf force is applied to gear A. At the output, the machinery (not shown) applies a force of F_B to the output gear. Gear A rotates at constant angular rate $\omega = 2$ rad/s, clockwise.

- What is the angular speed of the right gear?
- What is the velocity of point P?
- What is F_B ?
- If the gear bearings had friction, would F_B have to be larger or smaller in order to achieve the same constant velocity?

e) If instead of applying a 100 lbf to the left gear it is driven by a motor (not shown) at constant angular speed ω , what is the angular speed of the right gear?

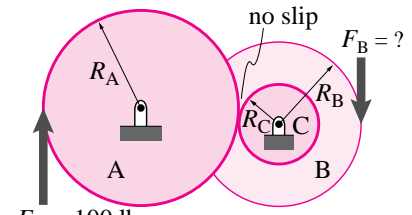

problem 7.77: Two gears.

(Filename:pg131.3)

7.78 Two racks connected by a gear. A 100 lbf force is applied to one rack. At the output the machinery (not shown) applies a force F_B to the other rack.

- Assume the gear is spinning at constant rate and is frictionless. What is F_B ?
- If the gear bearing had friction, would that increase or decrease F_B to achieve the same constant rate?

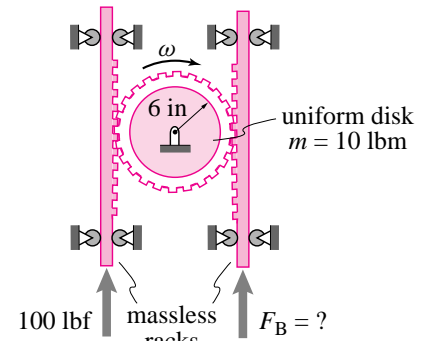

problem 7.78: Two racks connected by a gear.

(Filename:ch4.4)

7.79 Constant rate rack and pinion. The two gears shown are welded together and spin on a frictionless bearing. The inner gear has radius 0.5 m and negligible mass. The outer gear has 1 m radius and a uniformly distributed mass of 0.2 kg. A motor (not shown) rotates the disks at constant rate $\omega = 2$ rad/s. The gears drive the massless rack which is held in place by massless frictionless rollers as shown. The gears and the rack have teeth that are not shown in the figure. The point P is on the outer gear a distance 1.0 m from the center. At the time of interest, point P is on the positive y axis.

- What is the speed of point P? *
- What is the velocity of point P? *
- What is the acceleration of point P? *
- What is the velocity of the rack \vec{v} ? *
- What is the force on the rack due to its contact with the inner gear? *

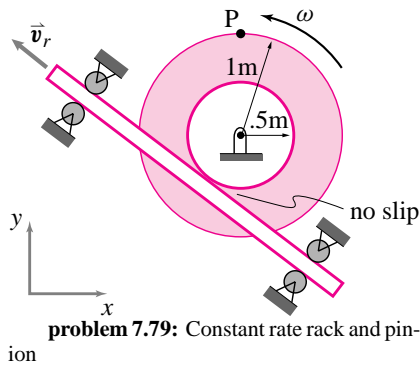

problem 7.79: Constant rate rack and pinion

(Filename:ch4.2)

7.80 Belt drives are used to transmit power between parallel shafts. Two parallel shafts, 3 m apart, are connected by a belt passing over the pulleys *A* and *B* fixed to the two shafts. The driver pulley *A* rotates at a constant 200 rpm. The speed ratio between the pulleys *A* and *B* is 1:2.5. The input torque is 350 N·m. Assume no loss of power between the two shafts.

- Find the input power. *
- Find the rotational speed of the driven pulley *B* * .
- Find the output torque at *B* * .

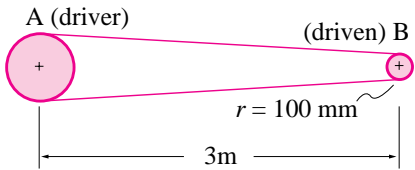

problem 7.80:

(Filename:pfigure4.rpd)

7.81 In the belt drive system shown, assume that the driver pulley rotates at a constant angular speed ω . If the motor applies a constant torque M_O on the driver pulley, show that the tensions in the two parts, *AB* and *CD*, of the belt must be different. Which part has a greater tension? Does your conclusion about unequal tension depend on whether the pulley is massless or not? Assume any dimensions you need.

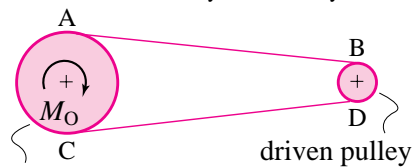

problem 7.81:

(Filename:pfigure4.rpe)

7.82 A belt drive is required to transmit 15 kW power from a 750 mm diameter pulley rotating at a constant 300 rpm to a 500 mm diameter pulley. The centers of the pulleys are located 2.5 m apart. The coefficient of friction between the belt and pulleys is $\mu = 0.2$.

- (See problem 7.102.) Draw a neat diagram of the pulleys and the belt-drive system and find the *angle of lap*, the contact angle θ , of the belt on the driver pulley.
- Find the rotational speed of the driven pulley.
- (See the figure in problem 7.102.) The power transmitted by the belt is given by *power = net tension × belt speed*, i.e., $P = (T_1 - T_2)v$, where v is the linear speed of the belt. Find the maximum tension in the belt. [Hint: $\frac{T_1}{T_2} = e^{\mu\theta}$ (see problem 7.102).]
- The belt in use has a 15 mm × 5 mm rectangular cross-section. Find the maximum tensile stress in the belt.

7.83 A bevel-type gear system, shown in the figure, is used to transmit power between two shafts that are perpendicular to each other. The driving gear has a mean radius of 50 mm and rotates at a constant speed $\omega = 150$ rpm. The mean radius of the driven gear is 80 mm and the driven shaft is expected to deliver a torque of $M_{out} = 25$ N·m. Assuming no power loss, find the input torque supplied by the driving shaft

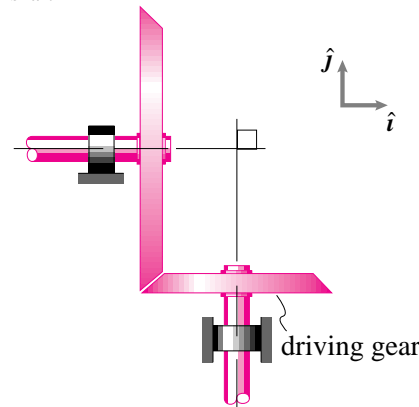

problem 7.83:

(Filename:pfigure4.rpa)

7.84 Disk pulleys. Two uniform disks *A* and *B* of *non-negligible* masses 10 kg and 5 kg respectively, are used as pulleys to hoist a block of mass 20 kg as shown in the figure. The block is pulled up by applying a force $F = 310$ N at one end of the string. Assume the string to be massless but ‘frictionful’ enough to not slide on the pulleys. Use $g = 10$ m/s².

- Find the angular acceleration of pulley *B* * .
- Find the acceleration of block *C* * .
- Find the tension in the part of the string between the block and the overhead pulley. *

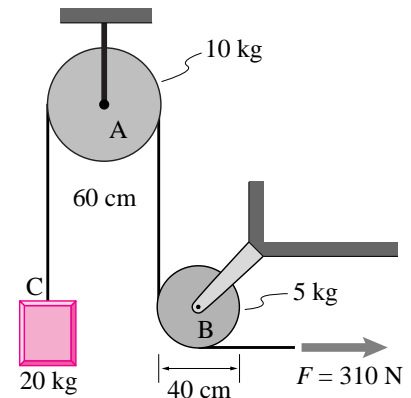

problem 7.84:

(Filename:pfigure.s94h8p4)

7.85 A spindle and pulley arrangement is used to hoist a 50 kg mass as shown in the figure. Assume that the pulley is to be of negligible mass. When the motor is running at a constant 100 rpm,

- Find the velocity of the mass at *B*.
- Find the tension in strings *AB* and *CD*.

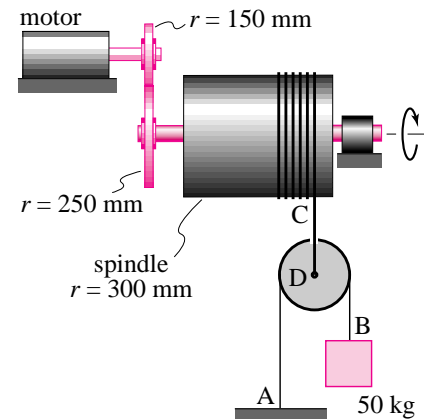

problem 7.85:

(Filename:pfigure4.rpg)

7.86 Two racks connected by three constant rate gears. See also problem 4.19. A 100 lbf force is applied to one rack. At the output, the machinery (not shown) applies a force F_B to the other rack.

- Assume the gear-train is spinning at constant rate and is frictionless. What is F_B ? *
- If the gear bearings had friction would that increase or decrease F_B to achieve the same constant rate?
- If instead of applying a 100 lbf to the left rack it is driven by a motor (not shown) at constant speed v , what is the speed of the right rack? *

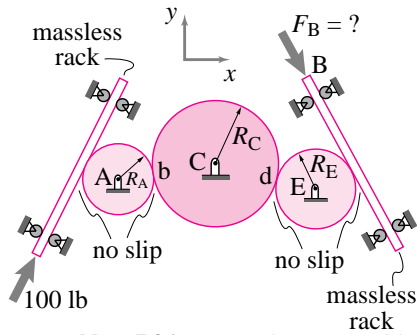

problem 7.86: Two racks connected by three gears.

(Filename:ch4.5)

7.87 Two racks connected by three accelerating gears. A 100 lbf force is applied to one rack. At the output, the machinery (not shown) applies a force of F_B to the other rack.

- Assume the gear-train is spinning at constant rate and is frictionless, what is F_B ?
- If the gear bearings had friction would that increase or decrease F_B to achieve the same constant rate?
- If the angular velocity of the gear is increasing at rate α does this increase or decrease F_B at the given ω .

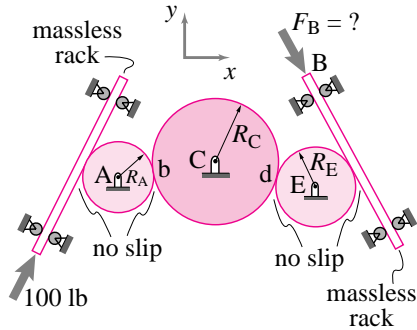

problem 7.87: Two racks connected by three gears.

(Filename:pg131.2)

7.88 3-D accelerating gear train. This is really a 2-D problem; each gear turns in a different parallel plane. Shaft B is rigidly connected to gears G_4 and G_5 . G_5 meshes with gear G_6 . Gears G_6 and G_5 are both rigidly attached to shaft AD. Gear G_5 meshes with G_2 which is welded to shaft A. Shaft A and shaft B spin independently. Assume you know the torque M_{input} , angular velocity ω_{input} and the angular acceleration α_{input} of the input shaft. Assume the bearings and contacts are frictionless.

- What is the input power?
- What is the output power?
- What is the angular velocity ω_{output} of the output shaft?
- What is the output torque M_{output} ?

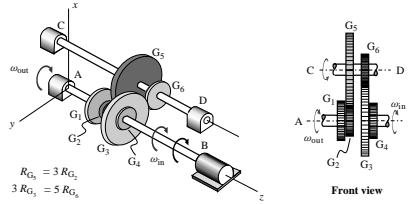

problem 7.88: A 3-D set of gears turning at constant rate.

(Filename:3dgeartrain)

7.89 A uniform disk of mass M and radius R rotates about a hinge O in the xy -plane. A point mass m is fixed to the disk at a distance $R/2$ from the hinge. A motor at the hinge drives the disk/point mass assembly with constant angular acceleration α . What torque at the hinge does the motor supply to the system?

7.90 The asymmetric dumbbell shown in the figure is pivoted in the center and also attached to a spring at one quarter of its length from the bigger mass. When the bar is horizontal, the compression in the spring is y_s . At the instant of interest, the bar is at an angle θ from the horizontal; θ is small enough so that $y \approx \frac{L}{2}\theta$. If, at this position, the velocity of mass ' m ' is $v\hat{j}$ and that of mass $3m$ is $-v\hat{j}$, evaluate the power term ($\sum \vec{F} \cdot \vec{v}$) in the energy balance equation.

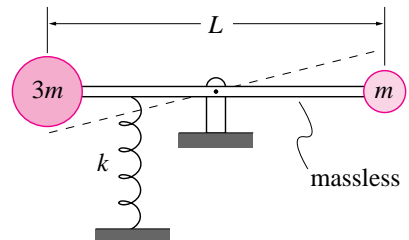

problem 7.90:

(Filename:pf1g2.3.rp4)

7.91 The dumbbell shown in the figure has a torsional spring with spring constant k (torsional stiffness units are $\frac{kN \cdot m}{rad}$). The dumbbell oscillates about the horizontal position with small amplitude θ . At an instant when the angular velocity of the bar is $\dot{\theta}\hat{k}$, the velocity of the left mass is $-L\dot{\theta}\hat{j}$ and that of the right mass is $L\dot{\theta}\hat{j}$. Find the expression for the power P of the spring on the dumbbell at the instant of interest.

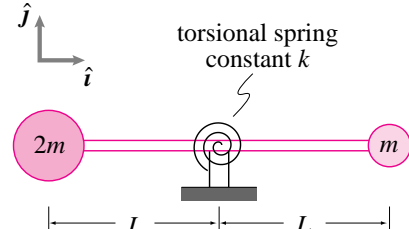

problem 7.91:

(Filename:pf1g2.3.rp10)

7.92 A physical pendulum. A swinging stick is sometimes called a 'physical' pendulum. Take the 'body', the system of interest, to be the whole stick.

- Draw a free body diagram of the system.
- Write the equation of angular momentum balance for this system about point O .
- Evaluate the left-hand-side as explicitly as possible in terms of the forces showing on your Free Body Diagram.
- Evaluate the right hand side as completely as possible. You may use the following facts:

$$\vec{v} = l\dot{\theta} \cos \theta \hat{j} - l\dot{\theta} \sin \theta \hat{i}$$

$$\vec{a} = -l\ddot{\theta}^2 [\cos \theta \hat{i} + \sin \theta \hat{j}] + l\ddot{\theta} [\cos \theta \hat{j} - \sin \theta \hat{i}]$$

where l is the distance along the pendulum from the top, θ is the angle by which the pendulum is displaced counter-clockwise from the vertically down position, \hat{i} is vertically down, and \hat{j} is to the right. You will have to set up and evaluate an integral.

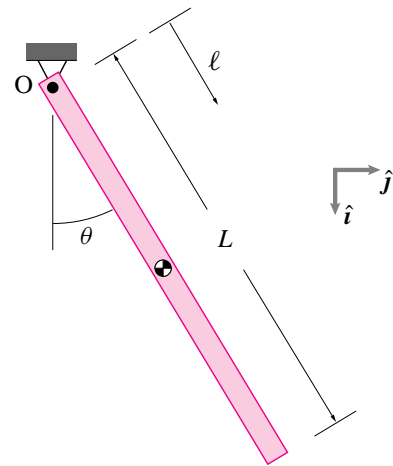

problem 7.92:

(Filename:ppend)

7.93 Which of (a), (b), and (c) are two force members?

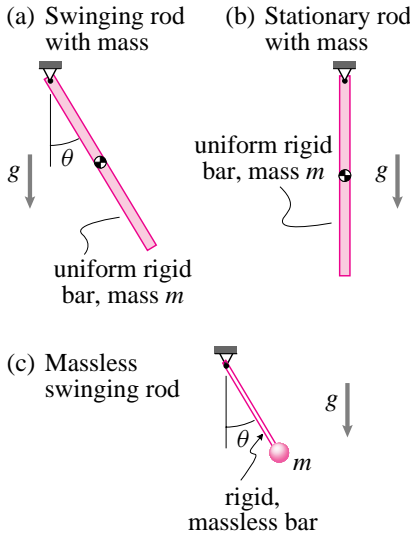

problem 7.93:

(Filename: pfigure2.two.force)

7.94 For the pendula in the figure :

- Without doing any calculations, try to figure out the relative durations of the periods of oscillation for the five pendula (i.e. the order, slowest to fastest) Assume small angles of oscillation.
- Calculate the period of small oscillations. [Hint: use balance of angular momentum about the point O]. *
- Rank the relative duration of oscillations and compare to your intuitive solution in part (a), and explain in words why things work the way they do.

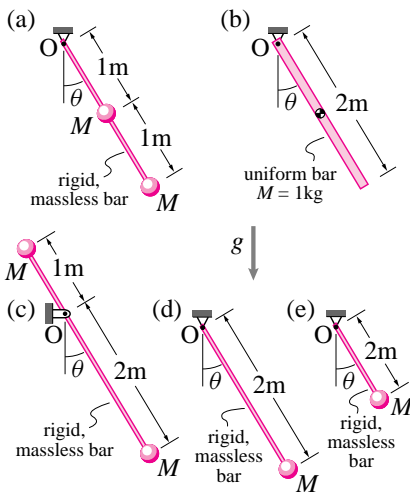

problem 7.94:

(Filename: pg144.1n)

7.95 A massless 10 meter long bar is supported by a frictionless hinge at one end and has a 3.759 kg point mass at the other end. It is released at $t = 0$ from a tip angle of $\phi = .02$ radians measured from vertically upright position (hinge at the bottom). Use $g = 10\text{m s}^{-2}$.

- Using a small angle approximation and the solution to the resulting linear differential equation, find the angle of tip at $t = 1\text{s}$ and $t = 7\text{s}$. Use a calculator, not a numerical integrator.
- Using numerical integration of the non-linear differential equation for an inverted pendulum find ϕ at $t = 1\text{s}$ and $t = 7\text{s}$.
- Make a plot of the angle versus time for your numerical solution. Include on the same plot the angle versus time from the approximate linear solution from part (a).
- Comment on the similarities and differences in your plots.

7.96 A spring-mass-damper system is depicted in the figure. The horizontal damping force applied at B is given by $F_D = -c\dot{y}_B$. The dimensions and parameters are as follows:

$$\begin{aligned} r_{B/O} &= 2ft \\ r_{A/O} &= \ell = 3ft \\ k &= 2\text{ lbf/ft} \\ c &= 0.3\text{ lbf} \cdot \text{s/ft} \end{aligned}$$

For small θ , assume that $\sin(\theta) \approx \theta$ and $\cos(\theta) \approx 1$.

- Determine the natural circular frequency of small oscillations about equilibrium for the pendulum shown. The static equilibrium position is $\theta = 0$ (pendulum hanging vertically), so the spring is at its rest point in this position. Idealize the pendulum as a point mass attached to a rigid massless rod of length ℓ , so $I^O = m\ell^2$. Also use the "small angle approximation" where appropriate.
- Sketch a graph of θ as a function of t ($t \geq 0$) if the pendulum is released from rest at position $\theta = 0.2$ rad when $t = 0$. Your graph should show the correct qualitative behavior, but calculations are not necessary.

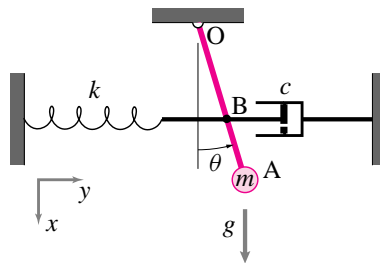

problem 7.96:

(Filename: pfigure.blue.157.2)

7.97 A rigid massless rod has two equal masses m_B and m_C ($m_B = m_C = m$) attached to it at distances $2L$ and 3ℓ , respectively, measured along the rod from a frictionless hinge located at a point A. The rod swings freely from the hinge. There is gravity. Let ϕ denote the angle of the rod measured from the vertical. Assume

that ϕ and $\dot{\phi}$ are known at the moment of interest.

- What is $\ddot{\phi}$? Solve in terms of m, ℓ, g, ϕ and $\dot{\phi}$.
- What is the force of the hinge on the rod? Solve in terms of $m, \ell, g, \phi, \dot{\phi}, \ddot{\phi}$ and any unit vectors you may need to define.
- Would you get the same answers if you put a mass $2m$ at 2.5ℓ ? Why or why not?

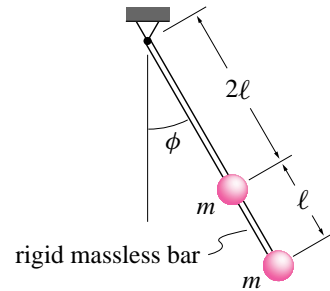

problem 7.97:

(Filename: pfigure.twomasspend)

7.98 See also problem 4.3. A zero length spring (relaxed length $\ell_0 = 0$) with stiffness $k = 5\text{ N/m}$ supports the pendulum shown.

- Find $\ddot{\theta}$ assuming $\dot{\theta} = 2\text{ rad/s}$, $\theta = \pi/2$. *
- Find $\ddot{\theta}$ as a function of $\dot{\theta}$ and θ (and k, ℓ, m , and g). *

[Hint: use vectors (otherwise it's hard)]

[Hint: For the special case, $kD = mg$, the solution simplifies greatly.]

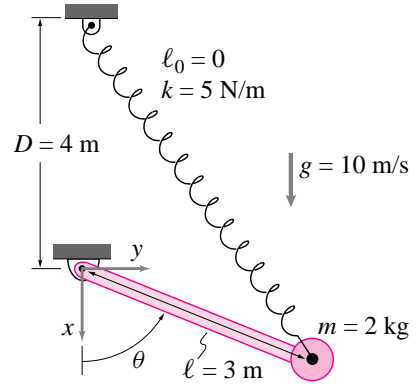

problem 7.98:

(Filename: pfigure.blue.80.2)

7.99 Robotics problem: Simplest balancing of an inverted pendulum. You are holding a stick upside down, one end is in your hand, the other end sticking up. To simplify things, think of the stick as massless but with a point mass at the upper end. Also, imagine that it is only a two-dimensional problem (either you can ignore one direction of falling for simplicity or imagine wire guides that keep the stick from moving in and out of the plane of the paper on which you draw the problem).

You note that if you model your holding the stick as just having a stationary hinge then you

get $\ddot{\phi} = \frac{g}{\ell} \sin \phi$. Assuming small angles, this hinge leads to exponentially growing solutions. Upside-down sticks fall over. How can you prevent this falling?

One way to do keep the stick from falling over is to firmly grab it with your hand, and if the stick tips, apply a torque in order to right it. This corrective torque is (roughly) how your ankles keep you balanced when you stand upright. Your task in this assignment is to design a robot that keeps an inverted pendulum balanced by applying appropriate torque.

Your model is: Inverted pendulum, length ℓ , point mass m , and a hinge at the bottom with a motor that can apply a torque T_m . The stick might be tipped an angle ϕ from the vertical. A horizontal disturbing force $F(t)$ is applied to the mass (representing wind, annoying friends, etc).

- Draw a picture and a FBD
- Write the equation for angular momentum balance about the hinge point. *
- Imagine that your robot can sense the angle of tip ϕ and its rate of change $\dot{\phi}$ and can apply a torque in response to that sensing. That is you can make T_m any function of ϕ and $\dot{\phi}$ that you want. Can you find a function that will make the pendulum stay upright? Make a guess (you will test it below).
- Test your guess the following way: plug it into the equation of motion from part (b), linearize the equation, assume the disturbing force is zero, and see if the solution of the differential equation has exponentially growing (i.e. unstable) solutions. Go back to (c) if it does and find a control strategy that works.
- Pick numbers and model your system on a computer using the full non-linear equations. Use initial conditions both close to and far from the upright position and plot ϕ versus time.
- If you are ambitious, pick a non-zero forcing function $F(t)$ (say a sine wave of some frequency and amplitude) and see how that affects the stability of the solution in your simulations.

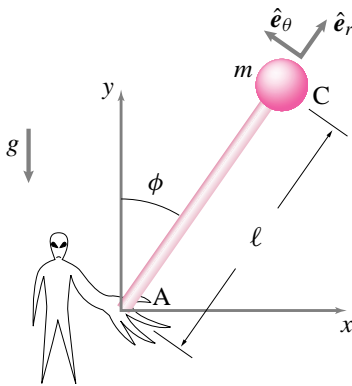

problem 7.99:

(Filename:pfigure.s94h9p1)

7.100 Balancing a system of rotating particles. A wire frame structure is made of four concentric loops of massless and rigid wires, connected to each other by four rigid wires presently coincident with the x and y axes. Three masses, $m_1 = 200$ grams, $m_2 = 150$ grams and $m_3 = 100$ grams, are glued to the structure as shown in the figure. The structure rotates counter-clockwise at a constant rate $\dot{\theta} = 5$ rad/s. There is no gravity.

- Find the net force exerted by the structure on the support at the instant shown. *
- You are to put a mass m at an appropriate location on the third loop so that the net force on the support is zero. Find the appropriate mass and the location on the loop.

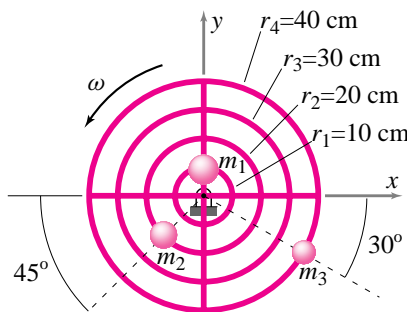

problem 7.100:

(Filename:pfigure.s94h6p2)

7.101 A rope of length ℓ and total mass m is held fixed at one end and whirled around in circular motion at a constant rate ω in the horizontal plane. Ignore gravity.

- Find the tension in the rope as a function of r , the radial distance from the center of rotation to any desired location on the rope. *
- Where does the maximum tension occur in the rope? *
- At what distance from the center of rotation does the tension drop to half its maximum value? *

7.102 Assume that the pulley shown in figure(a) rotates at a constant speed ω . Let the angle of contact between the belt and pulley surface be θ . Assume that the belt is massless and that the condition of impending slip exists between the pulley and the belt. The free body diagram of an infinitesimal section ab of the belt is shown in figure(b).

- Write the equations of linear momentum balance for section ab of the belt in the \hat{i} and \hat{j} directions.
- Eliminate the normal force N from the two equations in part (a) and get a differential equation for the tension T in terms of the coefficient of friction μ and The contact angle θ .

- Show that the solution to the equation in part (b) satisfies $\frac{T_1}{T_2} = e^{\mu\theta}$, where T_1 and T_2 are the tensions in the lower and the upper segments of the belt, respectively.

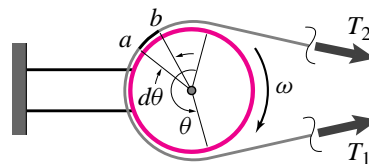

(a)

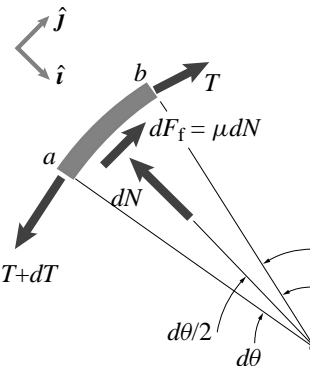

(b)

problem 7.102:

(Filename:pfigure4.rpf)

7.5 Polar moment of inertia:

I_{zz}^{cm} and I_{zz}^O

Skills

7.103 A point mass $m = 0.5$ kg is located at $x = 0.3$ m and $y = 0.4$ m in the xy -plane. Find the moment of inertia of the mass about the z -axis. *

7.104 A small ball of mass 0.2 kg is attached to a 1 m long inextensible string. The ball is to execute circular motion in the xy -plane with the string fully extended.

- What is value of I_{zz} of the ball about the center of rotation? *
- How much must you shorten the string to reduce the moment of inertia of the ball by half? *

7.105 Two identical point masses are attached to the two ends of a rigid massless bar of length ℓ (one mass at each end). Locate a point along the length of the bar about which the polar moment of inertia of the system is 20% more than that calculated about the mid point of the bar. *

7.106 A dumbbell consists of a rigid massless bar of length ℓ and two identical point masses m and m , one at each end of the bar.

- About which point on the dumbbell is its polar moment of inertia I_{zz} a minimum and what is this minimum value? *
- About which point on the dumbbell is its polar moment of inertia I_{zz} a maximum and what is this maximum value? *

7.107 Think first, calculate later. A light rigid rod AB of length 3ℓ has a point mass m at end A and a point mass $2m$ at end B . Point C is the center of mass of the system. First, answer the following questions without any calculations and then do calculations to verify your guesses.

- About which point A , B , or C , is the polar moment of inertia I_{zz} of the system a minimum? *
- About which point is I_{zz} a maximum? *
- What is the ratio of I_{zz}^A and I_{zz}^B ? *
- Is the radius of gyration of the system greater, smaller, or equal to the length of the rod? *

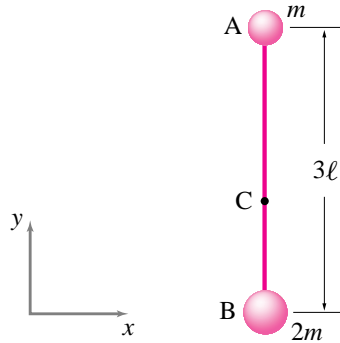

problem 7.107:

(Filename:pfigure4.4.rp1)

7.108 Do you understand the perpendicular axis theorem? Three identical particles of mass m are connected to three identical massless rods of length ℓ and welded together at point O as shown in the figure.

- Guess (no calculations) which of the three moment of inertia terms I_{xx}^O , I_{yy}^O , I_{zz}^O is the smallest and which is the biggest. *
- Calculate the three moments of inertia to check your guess. *
- If the orientation of the system is changed, so that one mass is along the x -axis, will your answer to part (a) change?
- Find the radius of gyration of the system for the polar moment of inertia. *

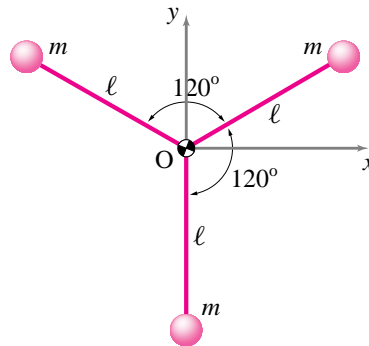

problem 7.108:

(Filename:pfigure4.4.rp3)

7.109 Show that the polar moment of inertia I_{zz}^O of the uniform bar of length ℓ and mass m , shown in the figure, is $\frac{1}{3}m\ell^2$, in two different ways:

- by using the basic definition of polar moment of inertia $I_{zz}^O = \int r^2 dm$, and
- by computing I_{zz}^{cm} first and then using the parallel axis theorem.

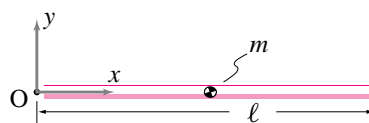

problem 7.109:

(Filename:pfigure4.4.rp5)

7.110 Locate the center of mass of the tapered rod shown in the figure and compute the polar moment of inertia I_{zz}^{cm} . [Hint: use the variable thickness of the rod to define a variable mass density per unit length.]

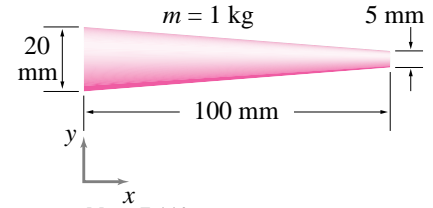

problem 7.110:

(Filename:pfigure4.4.rp6)

7.111 A short rod of mass m and length h hangs from an inextensible string of length ℓ .

- Find the moment of inertia I_{zz}^O of the rod.
- Find the moment of inertia of the rod I_{zz}^O by considering it as a point mass located at its center of mass.
- Find the percent error in I_{zz}^O in treating the bar as a point mass by comparing the expressions in parts (a) and (b). Plot the percent error versus h/ℓ . For what values of h/ℓ is the percentage error less than 5%?

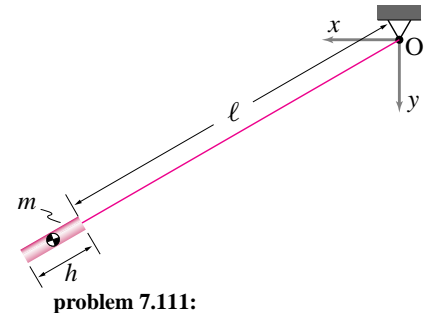

problem 7.111:

(Filename:pfigure4.4.rp11)

7.112 A small particle of mass m is attached to the end of a thin rod of mass M (uniformly distributed), which is pinned at hinge O , as depicted in the figure.

- Obtain the equation of motion governing the rotation θ of the rod.
- What is the natural frequency of the system for small oscillations θ ?

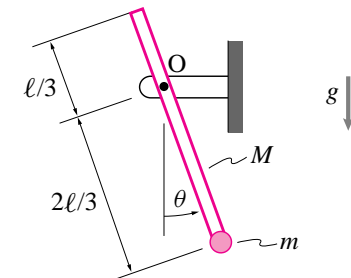

problem 7.112:

(Filename:pfigure.blue.151.3)

7.113 A thin rod of mass m and length ℓ is hinged with a torsional spring of stiffness K at A, and is connected to a thin disk of mass M and radius R at B. The spring is uncoiled when $\theta = 0$. Determine the natural frequency ω_n of the system for small oscillations θ , assuming that the disk is:

- welded to the rod, and *
- pinned frictionlessly to the rod. *

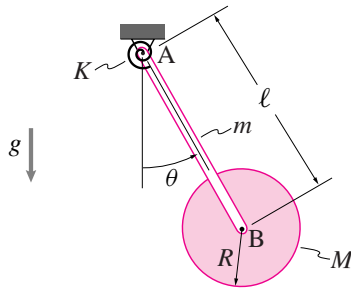

problem 7.113:

(Filename:pfigure.blue.151.4)

7.114 Do you understand the parallel axis theorem? A massless square plate $ABCD$ has four identical point masses located at its corners.

- Find the polar moment of inertia I_{zz}^{cm} . *
- Find a point P on the plate about which the system's moment of inertia I_{zz} is maximum? *
- Find the radius of gyration of the system. *

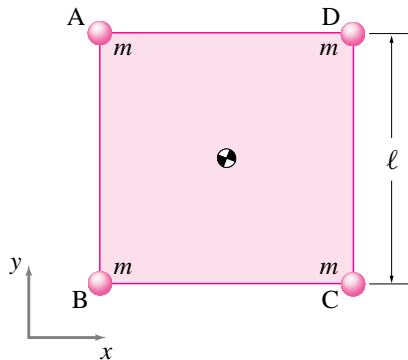

problem 7.114:

(Filename:pfigure4.4.rp2)

7.115 Perpendicular axis theorem and symmetry. For the massless square plate with four point masses on the corners, the polar moment of inertia $I_{zz}^{cm} = 0.6 \text{ kg} \cdot \text{m}^2$. Find I_{xx}^{cm} of the system. *

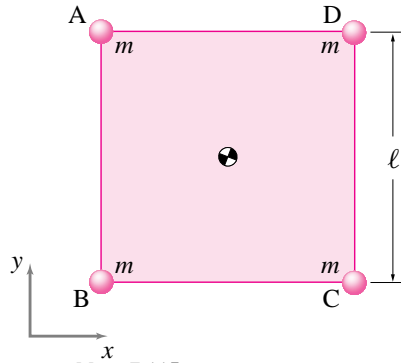

problem 7.115:

(Filename:pfigure4.4.rp4)

7.116 A uniform square plate (2 m on edge) has a corner cut out. The total mass of the remaining plate is 3 kg. It spins about the origin at a constant rate of one revolution every π s.

- What is the moment of inertia of the plate about point O?
- Where is the center of mass of the plate at the instant shown?
- What are the velocity and acceleration of the center of mass at the instant shown?
- What is the angular momentum of the plate about the point O at the instant shown?
- What are the total force and moment required to maintain this motion when the plate is in the configuration shown?
- What is the total kinetic energy of the plate?

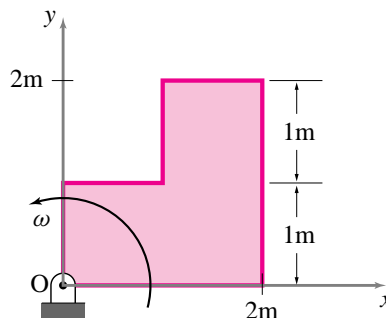

problem 7.116:

(Filename:pfigure.blue.87b.1)

7.117 A uniform thin triangular plate of mass m , height h , and base b lies in the xy -plane.

- Set up the integral to find the polar moment of inertia I_{zz}^O of the plate. *
- Show that $I_{zz}^O = \frac{m}{6}(h^2 + 3b^2)$ by evaluating the integral in part (a).
- Locate the center of mass of the plate and calculate I_{zz}^{cm} .

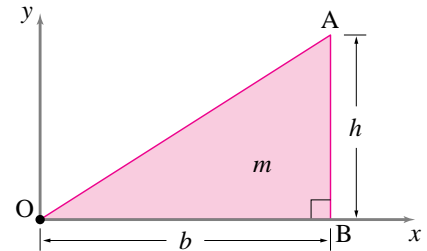

problem 7.117:

(Filename:pfigure4.4.rp9)

7.118 A uniform thin plate of mass m is cast in the shape of a semi-circular disk of radius R as shown in the figure.

- Find the location of the center of mass of the plate
- Find the polar moment of inertia of the plate, I_{zz}^{cm} . [Hint: It may be easier to set up and evaluate the integral for I_{zz}^O and then use the parallel axis theorem to calculate I_{zz}^{cm} .]

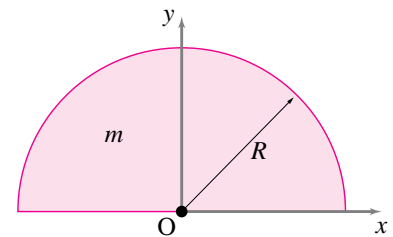

problem 7.118:

(Filename:pfigure4.4.rp10)

7.119 A uniform square plate of side $\ell = 250 \text{ mm}$ has a circular cut-out of radius $r = 50 \text{ mm}$. The mass of the plate is $m = \frac{1}{2} \text{ kg}$.

- Find the polar moment of inertia of the plate.
- Plot I_{zz}^{cm} versus r/ℓ .
- Find the limiting values of I_{zz}^{cm} for $r = 0$ and $r = \ell$.

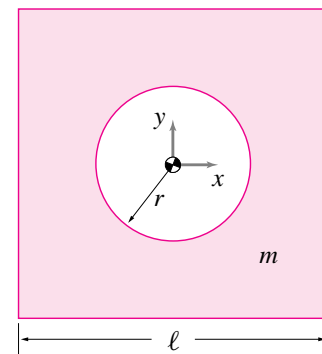

problem 7.119:

(Filename:pfigure4.4.rp7)

7.120 A uniform thin circular disk of radius $r = 100 \text{ mm}$ and mass $m = 2 \text{ kg}$ has a rectangular slot of width $w = 10 \text{ mm}$ cut into it as shown in the figure.

- Find the polar moment of inertia I_{zz}^O of the disk.

- b) Locate the center of mass of the disk and calculate I_{zz}^{cm} .

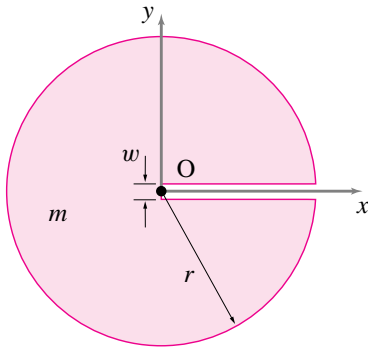

problem 7.120:

(Filename: pfigure.4.4.rp8)

- e) Assume that you don't know θ , $\dot{\theta}$ or $\ddot{\theta}$ but you do know that F_1 is applied to the rod, perpendicular to the rod at m_1 . What is $\dot{\theta}$? (Neglect gravity.)
 f) If F_1 were applied to m_2 instead of m_1 , would $\dot{\theta}$ be bigger or smaller?

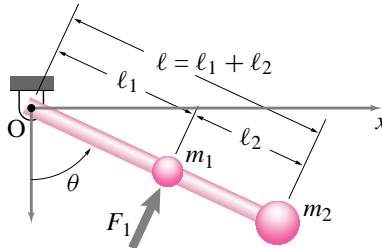

problem 7.122:

(Filename: pfigure.blue.82.1)

7.6 Using I_{zz}^{cm} and I_{zz}^O in mechanics equations

7.121 Motor turns a dumbbell. Two uniform bars of length ℓ and mass m are welded at right angles. At the ends of the horizontal bar are two more masses m . The bottom end of the vertical rod is attached to a hinge at O where a motor keeps the structure rotating at constant rate ω (counter-clockwise). What is the net force and moment that the motor and hinge cause on the structure at the instant shown?

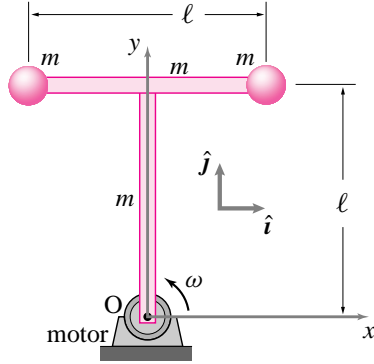

problem 7.121:

(Filename: pfigure.s94h5p5)

7.122 An object consists of a massless bar with two attached masses m_1 and m_2 . The object is hinged at O.

- What is the moment of inertia of the object about point O (I_{zz}^O)?
- Given θ , $\dot{\theta}$, and $\ddot{\theta}$, what is \vec{H}_O , the angular momentum about point O?
- Given θ , $\dot{\theta}$, and $\ddot{\theta}$, what is $\dot{\vec{H}}_O$, the rate of change of angular momentum about point O?
- Given θ , $\dot{\theta}$, and $\ddot{\theta}$, what is T , the total kinetic energy?

7.123 A uniform rigid rod rotates at constant speed in the xy -plane about a peg at point O. The center of mass of the rod may not exceed a specified acceleration $a_{max} = 0.5 \text{ m/s}^2$. Find the maximum angular velocity of the rod.

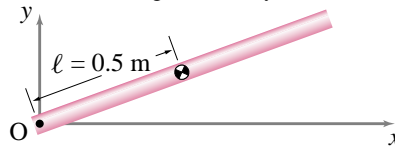

problem 7.123:

(Filename: pfigure.4.3.rp3)

7.124 A uniform one meter bar is hung from a hinge that is at the end. It is allowed to swing freely. $g = 10 \text{ m/s}^2$.

- What is the period of small oscillations for this pendulum?
- Suppose the rod is hung 0.4 m from one end. What is the period of small oscillations for this pendulum? Can you explain why it is longer or shorter than when it is hung by its end?

7.125 A motor turns a bar. A uniform bar of length ℓ and mass m is turned by a motor whose shaft is attached to the end of the bar at O. The angle that the bar makes (measured counter-clockwise) from the positive x axis is $\theta = 2\pi t^2/s^2$. Neglect gravity.

- Draw a free body diagram of the bar.
- Find the force acting on the bar from the motor and hinge at $t = 1 \text{ s}$.
- Find the torque applied to the bar from the motor at $t = 1 \text{ s}$.
- What is the power produced by the motor at $t = 1 \text{ s}$?

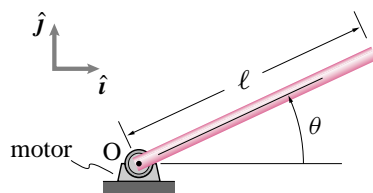

problem 7.125:

(Filename: pfigure.f93f1)

7.126 The rod shown is uniform with total mass m and length ℓ . The rod is pinned at point O. A linear spring with stiffness k is attached at the point A at height h above O and along the rod as shown. When $\theta = 0$, the spring is unstretched. Assume that θ is small for both parts of this problem.

- Find the natural frequency of vibration (in radians per second) in terms of m , g , h , ℓ and k .
- If you have done the calculation above correctly there is a value of h for which the natural frequency is zero. Call this value of h , h_{crit} . What is the behavior of the system when $h < h_{crit}$? (Desired is a phrase pointing out any qualitative change in the type of motion with some justification.)

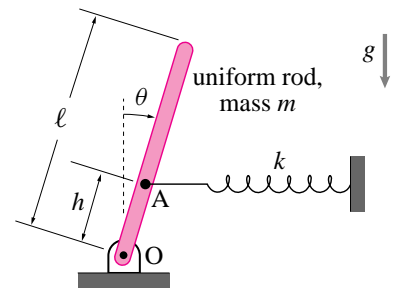

problem 7.126:

(Filename: pfigure.blue.153.2)

7.127 A uniform stick of length ℓ and mass m is a hair away from vertically up position when it is released with no angular velocity (a 'hair' is a technical word that means 'very small amount, zero for some purposes'). It falls to the right. What is the force on the stick at point O when the stick is horizontal. Solve in terms of ℓ , m , g , \hat{i} , and \hat{j} . Carefully define any coordinates, base vectors, or angles that you use.

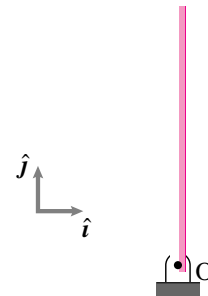

problem 7.127:

(Filename: pfigure.s94q8p1)

7.128 Acceleration of a trap door. A uniform bar AB of mass m and a ball of the same mass are released from rest from the same horizontal position. The bar is hinged at end A. There is gravity.

- Which point on the rod has the same acceleration as the ball, immediately after release. *
- What is the reaction force on the bar at end A just after release? *

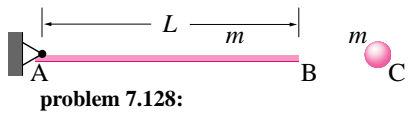

problem 7.128:

(Filename:pfigure.s94h8p3)

7.129 A pegged compound pendulum. See also problem 7.130. A uniform bar of mass m and length ℓ hangs from a peg at point C and swings in the vertical plane about an axis passing through the peg. The distance d from the center of mass of the rod to the peg can be changed by putting the peg at some other point along the length of the rod.

- Find the angular momentum of the rod as about point C.
- Find the rate of change of angular momentum of the rod about C.
- How does the period of the pendulum vary with d ? Show the variation by plotting the period against $\frac{d}{\ell}$. [Hint, you must first find the equations of motion, linearize for small θ , and then solve.] *
- Find the total energy of the rod (using the height of point C as a datum for potential energy).
- Find $\ddot{\theta}$ when $\theta = \pi/6$.
- Find the reaction force on the rod at C, as a function of m, d, ℓ, θ , and $\dot{\theta}$.
- For the given rod, what should be the value of d (in terms of ℓ) in order to have the fastest pendulum? *
- Test of Schuler's pendulum.** The pendulum with the value of d obtained in (g) is called the Schuler's pendulum. It is not only the fastest pendulum but also the "most accurate pendulum". The claim is that even if d changes slightly over time due to wear at the support point, the period of the pendulum does not change much. Verify this claim by calculating the percent error in the time period of a pendulum of length $\ell = 1$ m under the following three conditions: (i) initial $d = 0.15$ m and after some wear $d = 0.16$ m, (ii) initial $d = 0.29$ m and after some wear $d = 0.30$ m, and (iii) initial $d = 0.45$ m and after some wear $d = 0.46$ m. Which pendulum shows the least error in its time period? Do you see any connection between this result and the plot obtained in (c)?

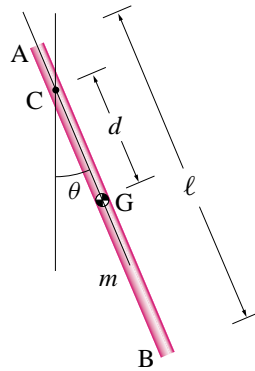

problem 7.129:

(Filename:pfigure.s94h8p6)

7.130 Given $\ddot{\theta}$, $\dot{\theta}$, and θ , what is the total kinetic energy of the pegged compound pendulum in problem 7.129?

7.131 A slender uniform bar AB of mass M is hinged at point O, so it can rotate around O without friction. Initially the bar is at rest in the vertical position as shown. A bullet of mass m and horizontal velocity V_o strikes the end A of the bar and sticks to it (an inelastic collision). Calculate the angular velocity of the system — the bar with its embedded bullet, immediately after the impact.

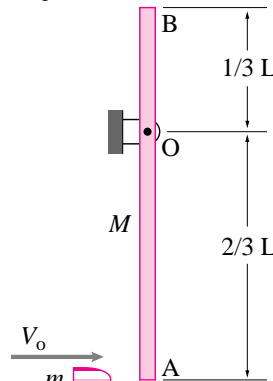

problem 7.131:

(Filename:pfigure.blue.78.1)

7.132 Motor turns a bent bar. Two uniform bars of length ℓ and uniform mass m are welded at right angles. One end is attached to a hinge at O where a motor keeps the structure rotating at a constant rate ω (counterclockwise). What is the net force and moment that the motor and hinge cause on the structure at the instant shown.

- neglecting gravity *
- including gravity. *

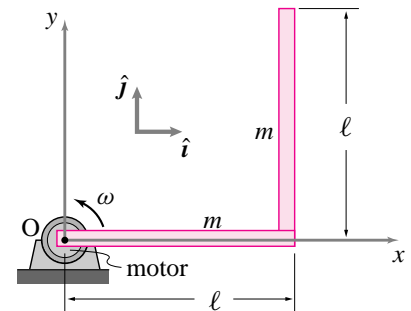

problem 7.132: A bent bar is rotated by a motor.

(Filename:pg85.3)

7.133 2-D problem, no gravity. A uniform stick with length ℓ and mass M_o is welded to a pulley hinged at the center O. The pulley has negligible mass and radius R_p . A string is wrapped many times around the pulley. At time $t = 0$, the pulley, stick, and string are at rest and a force F is suddenly applied to the string. How long does it take for the pulley to make one full revolution? *

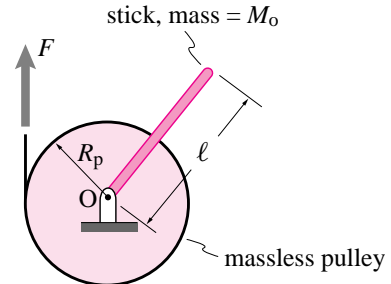

problem 7.133: String wraps around a pulley with a stick glued to it.

(Filename:p2.3)

7.134 A thin hoop of radius R and mass M is hung from a point on its edge and swings in its plane. Assuming it swings near to the position where its center of mass G is below the hinge:

- What is the period of its swinging oscillations?
- If, instead, the hoop was set to swinging in and out of the plane would the period of oscillations be greater or less?

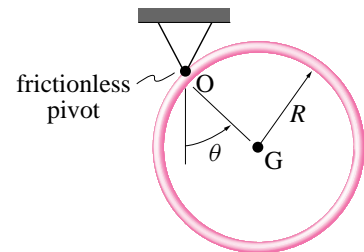

problem 7.134:

(Filename:pfigure.blue.145.1)

7.135 The uniform square shown is released from rest at $t = 0$. What is $\alpha = \dot{\omega} = \ddot{\theta}$ immediately after release?

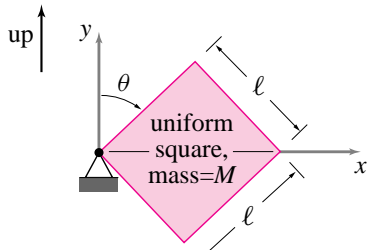

problem 7.135:

(Filename: pfigure.blue.42.2)

7.136 A square plate with side ℓ and mass m is hinged at one corner in a gravitational field g . Find the period of small oscillation.

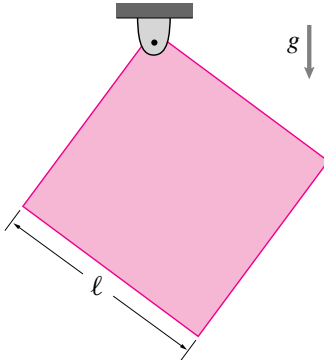

problem 7.136:

(Filename: p.f96.p3.2)

7.137 A wheel of radius R and moment of inertia I about the axis of rotation has a rope wound around it. The rope supports a weight W . Write the equation of conservation of energy for this system, and differentiate to find the equation of motion in terms of acceleration. Check the solution obtained by drawing separate free-body diagrams for the wheel and for the weight, writing the equations of motion for each body, and solving the equations simultaneously. Assume that the mass of the rope is negligible, and that there is no energy loss during the motion.

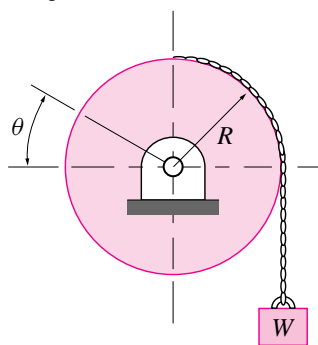

problem 7.137:

(Filename: pfigure.blue.136.1)

7.138 A disk with radius R has a string wrapped around it which is pulled with a force F . The disk is free to rotate about the axis through O normal to the page. The moment of inertia of the disk about O is I_O . A point A is

marked on the string. Given that $x_A(0) = 0$ and that $\dot{x}_A(0) = 0$, what is $x_A(t)$?

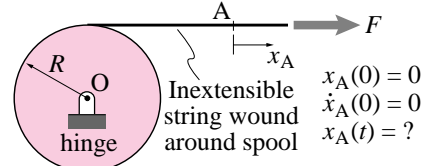

Spool has mass moment of inertia, I_O
problem 7.138:

(Filename: pfigure.blue.42.1)

7.139 Oscillating disk. A uniform disk with mass m and radius R pivots around a frictionless hinge at its center. It is attached to a massless spring which is horizontal and relaxed when the attachment point is directly above the center of the disk. Assume small rotations and the consequent geometrical simplifications. What is the period of oscillation of the disk if it is disturbed from its equilibrium configuration? [You may use the fact that, for the disk shown, $\vec{H}_O = \frac{1}{2}mR^2\dot{\theta}\hat{k}$, where θ is the angle of rotation of the disk.]*

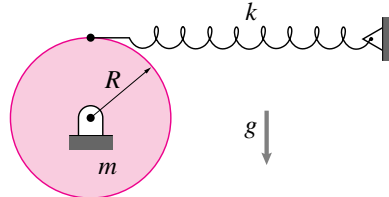

problem 7.139:

(Filename: pg147.2)

7.140 This problem concerns a narrow rigid hoop. For reference, here are dimensions and values you should use in this problem: mass of hoop $m_{\text{hoop}} = 1 \text{ kg}$ radius of hoop $R_{\text{hoop}} = 3 \text{ m}$, and gravitational acceleration $g = 10 \text{ m/s}^2$.

- The hoop is hung from a point on its edge and swings in its plane. Assuming it swings near to the position where its center of mass is below the hinge.
- What is the period of its swinging oscillations?
- If, instead, the hoop was set to swinging in and out of the plane would the period of oscillations be greater or less?

7.141 The compound pulley system shown in the figure consists of two pulleys rigidly connected to each other. The radii of the two pulleys are: $R_i = 0.2 \text{ m}$ and $R_o = 0.4 \text{ m}$. The combined moment of inertia of the two pulleys about the axis of rotation is $2.7 \text{ kg}\cdot\text{m}^2$. The two masses, $m_1 = 40 \text{ kg}$ and $m_2 = 100 \text{ kg}$, are released from rest in the configuration shown. Just after release,

- find the angular acceleration of the pulleys, and*
- find the tension in each string.*

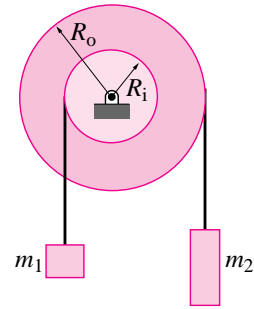

problem 7.141:

(Filename: summer95p2.1)

7.142 Consider a system of two blocks A and B and the reel C mounted at the fixed point O, as shown in the figure. Initially the system is at rest. Calculate the velocity for the block B after it has dropped a vertical distance h . Given: h , mass of block A, M_A , coefficient of friction μ , slope angle θ , mass of the reel, M_C , moment of inertia I about point O radius of gyration of the reel K_C , outer radius of the reel R_C , inner radius of the reel $\frac{1}{2}R_C$, mass of the block B M_B . The radius of gyration K is defined by $I_{zz}^{cm} = mK^2$. (Apply the work-energy principle.)*

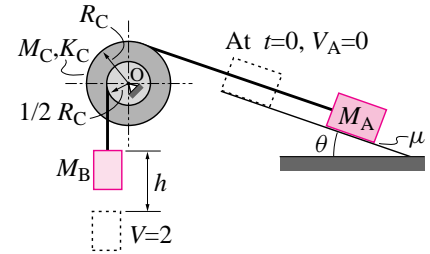

problem 7.142:

(Filename: pfigure.blue.135.1)

7.143 Gear A with radius $R_A = 400 \text{ mm}$ is rigidly connected to a drum B with radius $R_B = 200 \text{ mm}$. The combined moment of inertia of the gear and the drum about the axis of rotation is $I_{zz} = 0.5 \text{ kg}\cdot\text{m}^2$. Gear A is driven by gear C which has radius $R_C = 300 \text{ mm}$. As the drum rotates, a 5 kg mass m is pulled up by a string wrapped around the drum. At the instant of interest, The angular speed and angular acceleration of the driving gear are 60 rpm and 12 rpm/s , respectively. Find the acceleration of the mass m .*

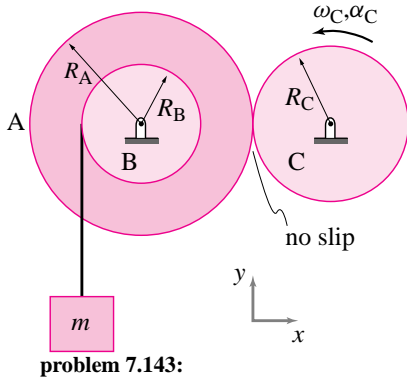

problem 7.143:

(Filename:summer95f.2)

7.144 Two gears accelerating. See also problems 7.77 and 4.16. At the input to a gear box a 100 lbf force is applied to gear A. At the output the machinery (not shown) applies a force of F_B to the output gear.

- Assume the gear is spinning at constant rate and is frictionless, what is F_B ?
- If the gear bearing had friction would that increase or decrease F_B ?
- If the angular velocity of the gear is increasing at rate α does this increase or decrease F_B at the given ω .

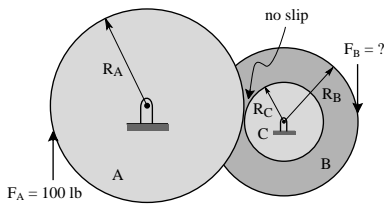

problem 7.144: Two gears.

(Filename:pg131.3.aa)

7.145 Frequently parents will build a tower of blocks for their children. Just as frequently, kids knock them down. In falling (even when they start to topple aligned), these towers invariably break in two (or more) pieces at some point along their length. Why does this breaking occur? What condition is satisfied at the point of the break? Will the stack bend towards or away from the floor after the break?

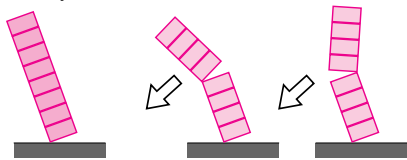

problem 7.145:

(Filename:pfigure.blue.129.1)

7.146 Massless pulley, dumbbell and a hanging mass. A mass M falls vertically but is withheld by a string which is wrapped around an ideal massless pulley with radius a . The pulley is welded to a dumbbell made of a massless rod welded to uniform solid spheres at A and B of radius R , each of whose center is a distance ℓ from O. At the instant in question,

the dumbbell makes an angle θ with the positive x axis and is spinning at the rate $\dot{\theta}$. Point C is a distance h down from O. In terms of some or all of $m, M, a, R, \ell, h, g, \theta, \dot{\theta}$, and \hat{j} , find the acceleration of the mass.

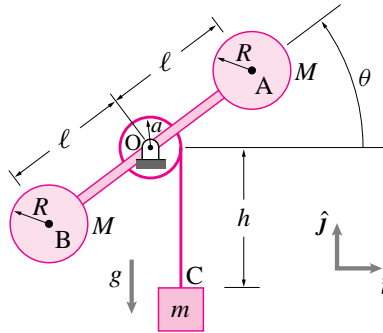

problem 7.146:

(Filename:s97p3.1)

7.147 Two racks connected by a gear. A 100 lbf force is applied to one rack. At the output the machinery (not shown) applies a force F_B to the other rack.

- Assume the gear is spinning at constant rate and is frictionless. What is F_B ?
- If the gear bearing had friction, would that increase or decrease F_B to achieve the same constant rate?
- If the angular velocity of the gear is increasing at rate α , does this increase or decrease F_B at the given ω .
- If the output load F_B is given then the motion of the machine can be found from the input load. Assume that the machine starts from rest with a given output load. So long as rack B moves in the opposite direction of the output force F_B the output power is positive.
 - For what values of F_B is the output power positive?
 - For what values of F_B is the output work maximum if the machine starts from rest and runs for a fixed amount of time?

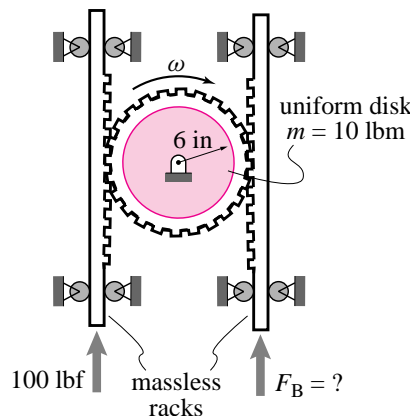

problem 7.147: Two racks connected by a gear.

(Filename:pg131.1)

7.148 2-D accelerating gear train. See also problem 7.74. Assume you know the torque $M_{input} = M_A$ and angular velocity $\omega_{input} = \omega_A$ of the input shaft. Assume the bearings and contacts are frictionless. Assume you also know the input angular acceleration $\dot{\omega}$ and the moments of inertia I_A, I_B and I_C of each of the disks about their centers.

- What is the input power?
- What is the output power?
- What is the angular velocity $\omega_{output} = \omega_C$ of the output shaft?
- What is the output torque $M_{output} = M_C$?

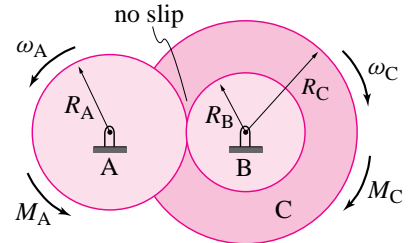

problem 7.148: A set of gears turning at variable rate.

(Filename:pg129.1)

7.149 A stick welded to massless gear that rolls against a massless rack which slides on frictionless bearings and is constrained by a linear spring. Neglect gravity. The spring is relaxed when the angle $\theta = 0$. Assume the system is released from rest at $\theta = \theta_0$. What is the acceleration of the point P at the end of the stick when $\theta = 0$? Answer in terms of any or all of $m, R, \ell, \theta_0, k, \hat{i}$, and \hat{j} . [Hint: There are several steps of reasoning required. You might want to draw FBD(s), use angular momentum balance, set up a differential equation, solve it, plug values into this solution, and use the result to find the quantities of interest.]

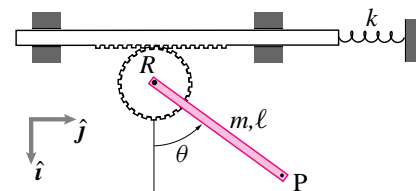

problem 7.149:

(Filename:p.f96.p2.2)

7.150 A tipped hanging sign is represented by a point mass m . The sign sits at the end of a massless, rigid rod which is hinged at its point of attachment to the ground. A taut massless elastic cord helps keep the rod vertical. The tension T in the very stretchy cord is idealized as constant during small displacements. (Note also that $\phi \equiv \theta$ during such motions). Consider all hinges to be frictionless and motions to take place in the plane of the paper.

- Write the angular momentum of the mass about O when the rod has an angular velocity $\dot{\theta}$.

- b) Find the differential equation that governs the mass's motion for small θ .
- c) Describe the motion for $T > \frac{mg}{2}$, $T = \frac{mg}{2}$, and $T < \frac{mg}{2}$. Interpret the differences of these cases in physical terms.

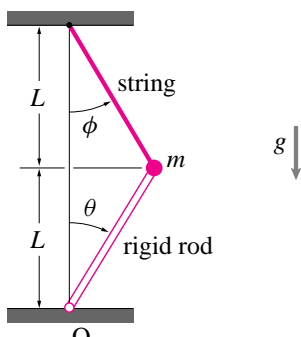

problem 7.150:

(Filename:pfigure.blue.153.1)

Problems for Chapter 8

Advanced topics in circular motion

8.1 3-D description of circular motion

8.1 If \vec{A} and \vec{B} are perpendicular, what is $|\vec{A} \times (\vec{A} \times \vec{B})|$ in terms of $|\vec{A}|$ and $|\vec{B}|$? (Hint: make a neat 3-D sketch.)

8.2 A circular disk of radius $r = 100$ mm rotates at constant speed ω about a fixed but unknown axis. At the instant when the disk is in the xy -plane, the angular velocity of each point on the diameter AB (which is parallel to the x -axis) is $\vec{v} = -2$ m/s \hat{k} . At the same instant, the magnitude of the acceleration of the center of mass C is 50 m/s².

- Find the angular velocity of the disk.
- Find the location of the axis of rotation.
- Find the acceleration of points A and B .

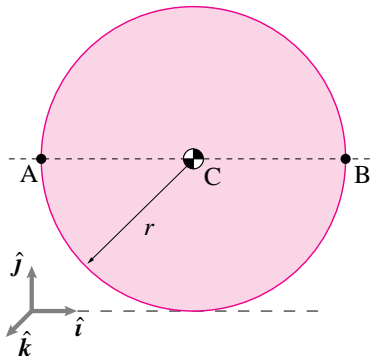

problem 8.2:

(Filename: pfigure4.3.rp10)

8.3 In the expression for normal acceleration $\vec{a}_n = \vec{\omega} \times (\vec{\omega} \times \vec{r})$, the parenthesis around $\vec{\omega} \times \vec{r}$ is important because vector product is nonassociative. Showing $\vec{\omega} \times (\vec{\omega} \times \vec{r}) \neq (\vec{\omega} \times \vec{\omega}) \times \vec{r}$ is almost trivial. (why?) Take $\vec{\omega}_1 = \omega_1 \hat{k}$, $\vec{\omega}_2 = \omega_2 \hat{i} + \omega_1 \hat{k}$ and $\vec{r} = a\hat{i} - b\hat{j}$ and show that $\vec{\omega}_1 \times (\vec{\omega}_2 \times \vec{r}) \neq (\vec{\omega}_1 \times \vec{\omega}_2) \times \vec{r}$.

8.4 In circular motion the velocity is $\vec{v} = \vec{\omega} \times \vec{r}$, where $\vec{\omega}$ is the angular velocity and \vec{r} is the position vector of the point of interest relative to a point on the axis of rotation. Compute \vec{v} in the three cases below, draw the circular orbit, and show the vectors $\vec{\omega}$, \vec{r} , and \vec{v} .

- $\vec{\omega} = 2$ rad/s \hat{k} , $\vec{r} = 3$ m $\hat{i} + 4$ m \hat{j} .
- $\vec{\omega} = 4.33$ rad/s $\hat{i} + 2.5$ rad/s \hat{j} , $\vec{r} = 0.5$ m $\hat{i} - 0.87$ m \hat{j} .

c) $\vec{\omega} = 2$ rad/s $\hat{i} + 2$ rad/s $\hat{j} + 2.83$ rad/s \hat{k} , $\vec{r} = 3.5$ m $\hat{i} + 3.5$ m $\hat{j} - 4.95$ m \hat{k} .

8.5 The following questions are about the velocity and acceleration formulae for the non-constant rate circular motion about a fixed axis:

$$\vec{v} = \vec{\omega} \times \vec{r}$$

$$\vec{a} = \vec{\omega} \times \vec{r} + \vec{\omega} \times (\vec{\omega} \times \vec{r})$$

- a) For planar circular motion about the z -axis, take

$$\vec{\omega} = \alpha \hat{k}, \quad \vec{\omega} = \omega \hat{k}, \quad \text{and} \quad \vec{r} = R \hat{e}_R$$

and show that the velocity and acceleration formulae reduce to the formulae from elementary physics: $\vec{v} = \omega R \hat{e}_\theta$ and $\vec{a} = -\omega^2 R \hat{e}_R + R \alpha \hat{e}_\theta$.

- b) Draw a schematic picture of a particle (or a point on a rigid body) going in circles about a fixed axis in 3-D. Take two distinct points on the axis and draw vectors \vec{r}_1 and \vec{r}_2 from these two points to the particle of interest. Show, using the formulae for \vec{v} and \vec{a} above, that the acceleration and velocity of the particle are the same irrespective of which \vec{r} is used and thus conclude that the vector \vec{r} can be taken from any point on the axis of rotation.

8.6 A rectangular plate with width $w = 1$ m and length $\ell = 2$ m is rigidly attached to a shaft along one of its edges. The shaft rotates about the x -axis. The center of mass of the plate goes around at a constant linear speed $v = 2.5$ m/s.

- Find the angular velocity of the plate.
- At the instant shown, find the velocity of point P .

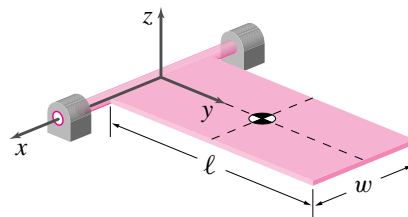

problem 8.6:

(Filename: pfigure4.3.rp1)

8.7 The solid cylinder shown has an angular velocity $\vec{\omega}$ of magnitude 40 rad/s. The vector $\vec{\omega}$ lies in the yz -plane. The origin O of the coordinate frame is at the center of the cylinder and is at rest. Find the following quantities:

- The vector $\vec{\omega}$.
- The velocity $\vec{v}_{A/B}$ of point A relative to point B .

- c) The acceleration \vec{a}_A of point A .

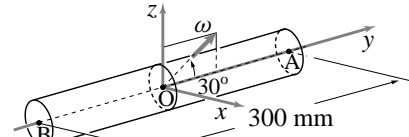

problem 8.7:

(Filename: pfigure.blue.37.1)

8.8 A rigid body rotates about a fixed axis and has an angular acceleration $\alpha = 3\pi^2(\hat{i} + 1.5\hat{j} + 1.5\hat{k})$ rad/s². At a certain instant, the velocity of a point A of the body has x -component and y -component equal to 3 and -4 m/s, respectively. Find the magnitude v_A of the velocity of point A .

8.9 Particle attached to a shaft, no gravity. See also problem 8.10. A shaft of negligible mass spins at a constant rate. The motor at A imposes this rate if needed. The bearing at A prevents translation of its end of the shaft in any direction but causes no torques other than that of the motor (which causes a torque in the \hat{k} direction). The frictionless bearing at C holds that end of the shaft from moving in the \hat{i} and \hat{j} directions but allows slip in the \hat{k} direction. A bar of negligible mass is welded at right angles to the shaft. A small sphere of mass 1 kg is attached to the free end of the bar. There is no gravity. The shaft is spinning counterclockwise (when viewed from the positive \hat{k} direction) at 3 rad/s. In the configuration of interest the rod BD is parallel to the \hat{i} direction.

- What is the position vector of the mass in the given coordinate system at the instant of interest?
- What is angular velocity vector of the shaft?
- What are the velocity and acceleration of the particle at the instant of interest?

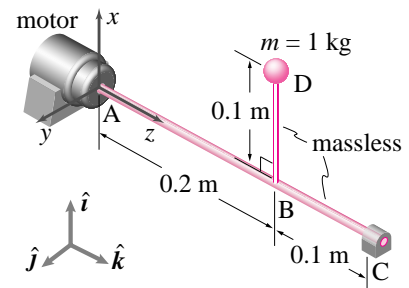

problem 8.9:

(Filename: ch4.9)

8.10 Reconsider the particle on a shaft in problem 8.9.

- What is the velocity of a point halfway down the rod BD relative to the velocity of the mass at D ?
- What is the acceleration of a point halfway down the rod BD relative to the acceleration of the mass at D ?

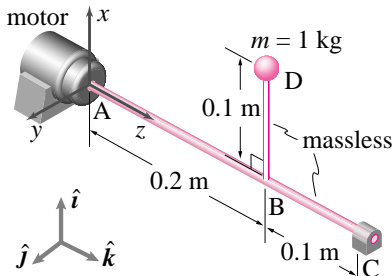

problem 8.10: Particle attached to a shaft, no gravity

(Filename: pfigure4.particleshaft1.a)

8.11 Particle attached to a shaft, no gravity.

See also problem 8.12. A shaft of negligible mass spins at variable rate. The motor at A imposes this rate if needed. The bearing at A prevents translation of its end of the shaft in any direction but causes no torques other than that of the motor (which causes a torque in the \hat{k} direction). The frictionless bearing at C holds that end of the shaft from moving in the \hat{i} and \hat{j} directions but allows slip in the \hat{k} direction. The shaft is welded orthogonally to a bar, also of negligible mass, which is attached to a small ball of (non-negligible) mass of 1 kg. There is no gravity. At the instant of interest, the shaft is spinning counterclockwise (when viewed from the positive \hat{k} direction) at $\omega = 3 \text{ rad/s}$ and $\dot{\omega} = 5 \text{ rad/s}^2$. In the configuration of interest the rod BD is parallel with the \hat{i} direction.

- In the coordinate system shown, what is the position vector of the particle at the instant of interest?
- In the coordinate system shown, what are angular velocity and angular acceleration vectors of the shaft?
- In the coordinate system shown, what is the velocity and acceleration of the particle at the instant of interest?

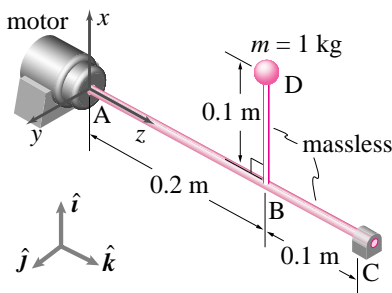

problem 8.11:

(Filename: ch5.3)

8.12 Reconsider the particle on a shaft in problem 8.11. What is the velocity and acceleration

of a point halfway down the rod BD relative to the velocity and acceleration of the particle?

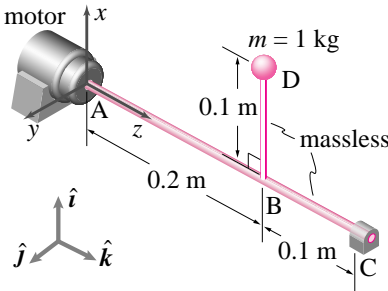

problem 8.12:

(Filename: ch5.3.copy)

8.13 Crooked rod. A one meter long uniform rod is welded at its center at an angle ϕ to a shaft as shown. The shaft is supported by bearings at its ends and spins at a constant rate ω . At the instant of interest, the crooked rod lies in the xy -plane.

- In the coordinate system shown, what is the position vector of the point P on the rod at the instant of interest? *
- In the coordinate system shown, what is the velocity and acceleration of point P at the instant of interest? *

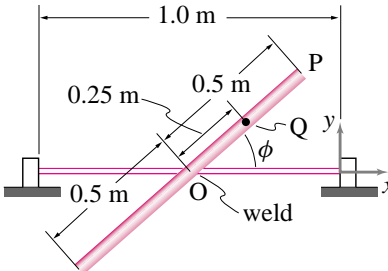

problem 8.13: A crooked rod spins on a shaft.

(Filename: ch4.7)

8.14 Crooked rod, again. Reconsider the crooked rod on a shaft in problem 8.13. What are the velocity and acceleration of point P relative to point Q ?

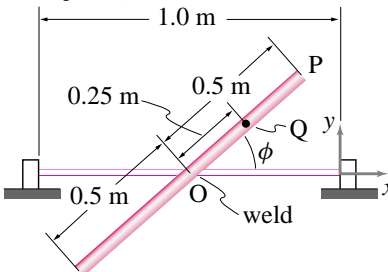

problem 8.14: A crooked rod spins on a shaft.

(Filename: pfigure4.crooked.a)

8.15 Crooked rod. A one meter long uniform rod is welded at its center at an angle ϕ to a shaft as shown. The shaft is supported by bearings at its ends and spins at a variable rate. At the instant of interest the shaft is spinning counterclockwise (when viewed from the positive

x direction) at angular speed ω with angular acceleration $\dot{\omega}$. At the instant of interest, the crooked rod lies in the xy -plane.

- In the coordinate system shown, what is the position vector of the point P on the rod?
- In the coordinate system shown, what are angular velocity and angular acceleration vectors of the rod and shaft?
- In the coordinate system shown, what is the velocity and acceleration of point P ?
- What is the velocity and acceleration of point P relative to point Q ?

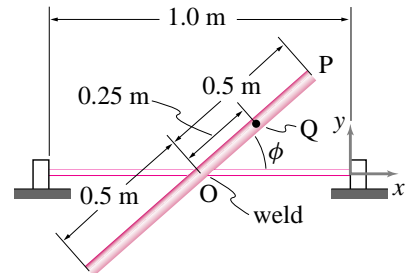

problem 8.15: A crooked rod spins on a shaft.

(Filename: ch5.4)

8.16 A rigid rod OP of length $L = 500 \text{ mm}$ is welded to a shaft AB at an angle $\theta = 30^\circ$. The shaft rotates about its longitudinal axis at a constant rate $\omega = 120 \text{ rpm}$. At the instant shown, the rod OP is in the xz -plane.

- Neatly draw the path of point P . At the instant shown, draw the basis vectors \hat{e}_r and \hat{e}_θ and express them in terms of the basis vectors $\hat{i}, \hat{j}, \hat{k}$.
- Find the radius of the circular path of point P and calculate the velocity and acceleration of the point using planar circular motion formulae $\vec{v} = \theta \hat{e}_\theta$ and $\vec{a} = -\dot{\theta}^2 R \hat{e}_r$.
- Find the position vector $\vec{r} \equiv \vec{r}_{P/O}$ of point P . Use this position vector to compute the velocity and acceleration of point P using the general formulae $\vec{v} = \vec{\omega} \times \vec{r}$ and $\vec{a} = \vec{\omega} \times \vec{\omega} \times \vec{r}$. Show that the answers obtained here are the same as those in (b).

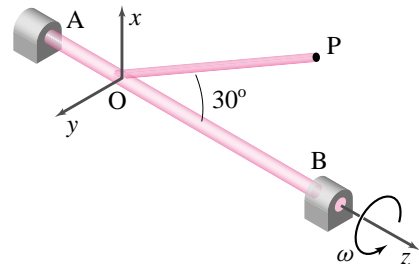

problem 8.16:

(Filename: pfigure4.2.rp1)

8.17 A uniform rectangular plate $ABCD$ of width ℓ and length 2ℓ rotates about its diagonal AC at a constant angular speed $\omega = 5$ rad/s. At the instant shown, the plate is in the xz -plane.

- Find the velocity and acceleration of point B at the instant shown.
- Find the velocity and acceleration of point B when the plate is in the yz -plane.

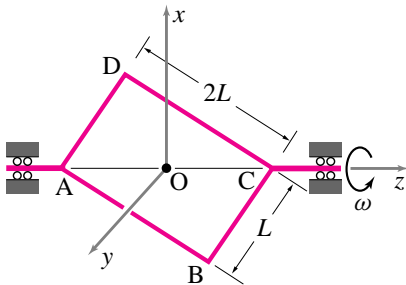

problem 8.17:

(Filename:pfimage4.2.rp2)

8.18 A rectangular plate of width $w = 100$ mm and length $\ell = 200$ mm rotates about one of its diagonals at a constant angular rate $\omega = 3$ rad/s. There is a fixed coordinate system xyz with the origin at the center of the plate and the x -axis aligned with the axis of rotation. Another set of axes $x'y'z'$, aligned with the principal axes of the plate, has the same origin but is attached to the plate and therefore, rotates with the plate. At the instant of interest, the plate is in the xy -plane and the two axes z and z' coincide. Find the velocity of the corner point P as follows:

- Write the angular velocity $\vec{\omega}$ of the plate in terms of its components in the two coordinate systems.
- Find the velocity of point P in both coordinate systems using the expressions for $\vec{\omega}$ found in part (a).
- Find the perpendicular distance d of point P from the axis of rotation, and show that the linear speed of point P calculated from velocities found in part (b) is ωd in each case.

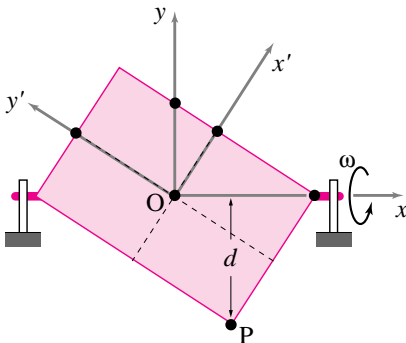

problem 8.18:

(Filename:pfimage4.3.rp11)

8.19 A cone of angle β sits on its side on a horizontal disk of radius $r = 100$ mm as shown in the figure. The cone is attached to shaft AB

that turns in the bearing. The disk rotates at a constant angular speed $\omega = 120$ rpm. Assume that the cone rolls without slip on the disk. Thus, the disk drives the cone-and-shaft assembly causing it to turn in the bearing. Find the angular velocity of the cone as a function of the cone angle β . In particular, find the angular velocity of the cone for

- $\beta = 30^\circ$, and
- $\beta = 90^\circ$ (or 90° minus a hair if that makes you more comfortable).

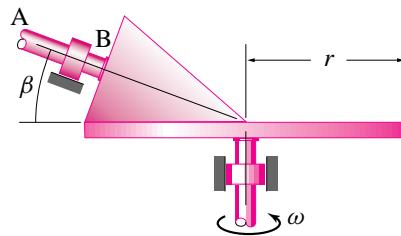

problem 8.19:

(Filename:pfimage4.rpb)

8.2 Dynamics of fixed axis rotation

8.20 Let $P(x, y, z)$ be a point mass on an abstract massless body that rotates at a constant rate ω about the z -axis. Let $C(0, 0, z)$ be the center of the circular path that P describes during its motion.

- Show that the rate of change of angular momentum of mass P about the origin O is given by

$$\dot{\vec{H}}_O = -m\omega^2 R z \hat{e}_\theta$$

where $R = \sqrt{x^2 + y^2}$ is the radius of the circular path of point P .

- Is there any point on the axis of rotation (z -axis) about which $\dot{\vec{H}}$ is zero. Is this point unique?

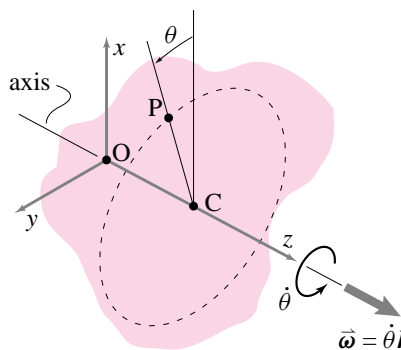

problem 8.20:

(Filename:pfimage4.2.rp5)

8.21 System of Particles going in a circle. Assume for the problems below that you have two mass points going in circles about a common axis at a fixed common angular rate.

- 2-D (particles in the plane, axis of rotation normal to the plane). Show, by calculating the sum in \vec{H}_C that the result is the same when using the two particles or when using a single particle at the center of mass (with mass equal to the sum of the two particles). You may do the general problem or you may pick particular appropriate locations for the masses, particular masses for the masses, a specific point C , a specific axis and a particular rotation rate.
- 3-D (particles *not* in a common plane normal to the axis of rotation). Using particular mass locations that you choose, show that 2 particles give a *different* value for \vec{H}_C than a single particle at the center of mass. [Moral: In general, $\dot{\vec{H}}_C \neq \vec{r}_{cm/C} \times m_{tot} \vec{\omega}_{cm}$.]

8.22 The rotating two-mass system shown in the figure has a constant angular velocity $\vec{\omega} = 12$ rad/s \hat{i} . Assume that at the instant shown, the masses are in the xy -plane. Take $m = 1$ kg and $L = 1$ m.

- Find the linear momentum \vec{L} and its rate of change $\dot{\vec{L}}$ for this system.
- Find the angular momentum \vec{H}_O about point O and its rate of change $\dot{\vec{H}}_O$ for this system.

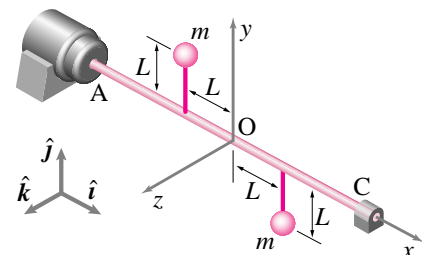

problem 8.22:

(Filename:pfimage4.2.rp4)

8.23 Particle attached to a shaft, no gravity. A shaft of negligible mass spins at constant rate. The motor at A imposes this rate if needed. The bearing at A prevents translation of its end of the shaft in any direction but causes no torques other than that of the motor (which causes a torque in the \hat{k} direction). The frictionless bearing at C holds that end of the shaft from moving in the \hat{i} and \hat{j} directions but allows slip in the \hat{k} direction. The shaft is welded orthogonally to a bar, also of negligible mass, which is attached to a small ball of (non-negligible) mass of 1 kg. There is no gravity. The shaft is spinning counterclockwise (when viewed from the positive \hat{k} direction) at 3 rad/s. In the configuration of interest the rod BD is parallel with the \hat{i} direction.

- What is the tension in the rod BD ? *
- What are all the reaction forces at A and C ? *

- c) What is the torque that the motor at A causes on the shaft? *
- d) There are two ways to do problems (b) and (c): one is by treating the shaft, bar and mass as one system and writing the momentum balance equations. The other is to use the result of (a) with action-reaction to do statics on the shaft BC. Repeat problems (b) and (c) doing it the way you did not do it the first time.

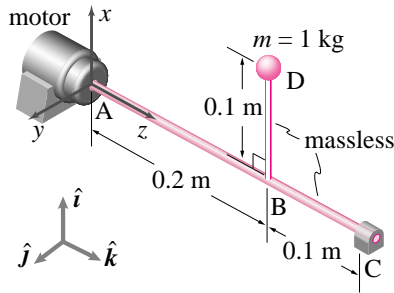

problem 8.23:

(Filename:pfigure.s94h7p1)

8.24 Particle attached to a shaft, with gravity. Consider the same situation as in problem 8.23 with the following changes: There is gravity (pointing in the $-\mathbf{i}$ direction). At the time of interest the rod BD is parallel to the $+\mathbf{j}$ direction.

- a) What is the force on D from the rod BD? (Note that the rod BD is *not* a 'two-force' member. Why not?)
- b) What are all the reaction forces at A and C?
- c) What is the torque that the motor at A causes on the shaft?
- d) Do problems (b) and (c) again a different way.

8.25 A turntable rotates at the constant rate of $\omega = 2 \text{ rad/s}$ about the z axis. At the edge of the 2 m radius turntable swings a pendulum which makes an angle ϕ with the negative z direction. The pendulum length is $\ell = 10 \text{ m}$. The pendulum consists of a massless rod with a point mass $m = 2 \text{ kg}$ at the end. The gravitational constant is $g = 10 \text{ m/s}^2$ pointing in the $-z$ direction. A perspective view and a side view are shown.

- a) What possible angle(s) could the pendulum make in a steady motion. In other words, find ϕ for steady circular motion of the system. It turns out that this quest leads to a transcendental equation. You are not asked to solve this equation but you should have the equation clearly defined. *
- b) How many solutions are there? [hint, sketch the functions involved in your final equation.] *
- c) Sketch very approximately any equilibrium solution(s) not already sketched on the side view in the picture provided.

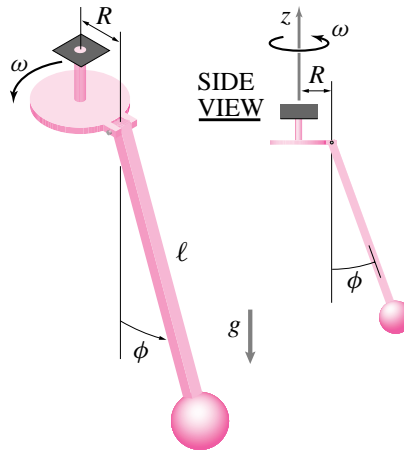

problem 8.25:

(Filename:pfigure.s95q6)

8.26 Mr. X swings his daughter Y about the vertical axis at a constant rate $\omega = 1 \text{ rad/s}$. Y is merely one year old and weighs 12 kg . Assuming Y to be a point mass located at the center of mass, estimate the force on each of her shoulder joints.

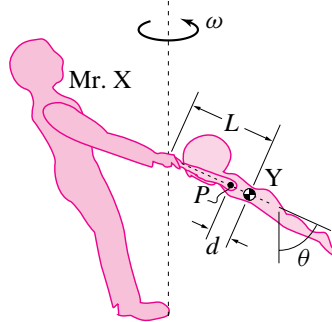

problem 8.26:

(Filename:pfigure4.2.rp12)

8.27 A block of mass $m = 2 \text{ kg}$ supported by a light inextensible string at point O sits on the surface of a rotating cone as shown in the figure. The cone rotates about its vertical axis of symmetry at constant rate ω . Find the value of ω in rpm at which the block loses contact with the cone.

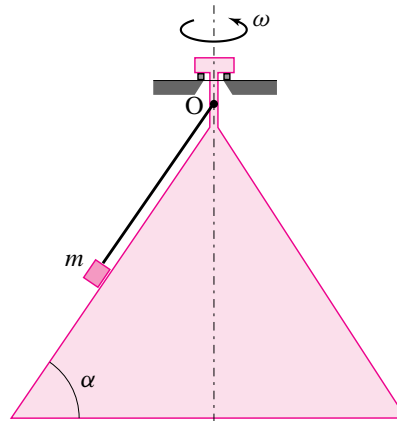

problem 8.27:

(Filename:pfigure4.2.rp11)

8.28 A small rock swings in circles at constant angular rate ω . It is hung by a string with length ℓ the other end of which is at the origin of a good coordinate system. The rock has mass m and the gravitational constant is g . The string makes an angle of ϕ with the negative z axis. The mass rotates so that if you follow it with the fingers of your right hand, your right thumb points up the z -axis. At the moment of interest the mass is passing through the yz -plane.

- a) Draw a free body diagram of the rock.
- b) How long does it take to make one revolution? How does this compare with the period of oscillation of a simple pendulum. *
- c) Find the following quantities in any order that pleases you. All solutions should be in terms of m, g, ℓ, ϕ, ω and the unit vectors \hat{i}, \hat{j} , and \hat{k} .
 - The tension in the string (T).
 - The velocity of the rock (\vec{v}).
 - The acceleration of the rock (\vec{a}).
 - The rate of change of the angular momentum about the $+x$ axis (dH_x/dt).

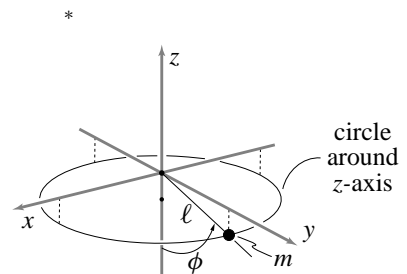

problem 8.28:

(Filename:pfigure.blue.14.2)

8.29 Consider the configuration in problem 8.28. What is the relation between the angle (measured from the vertical) at which it hangs and the speed at which it moves? Do an experiment with a string, weight and stop watch to check your calculation. *

8.30 A small block of mass $m = 5 \text{ kg}$ sits on an inclined plane which is supported by a bearing at point O as shown in the figure. At the instant of interest, the block is at a distance $L = 0.5 \text{ m}$ from where the surface of the incline intersects the axis of rotation. By experiments, the limiting rate of rotation of the turntable before the block starts sliding up the inclined plane is found to be $\omega = 125 \text{ rpm}$. Find the coefficient of friction between the block and the incline.

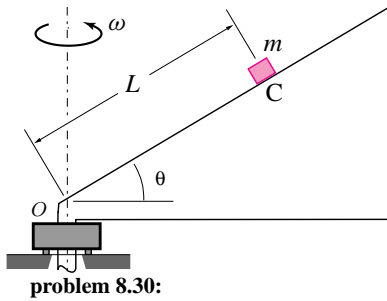

problem 8.30: (Filename:pfigure4.2.rp9)

8.31 Particle sliding in circles in a parabolic bowl. As if in a James Bond adventure in a big slippery radar bowl, a particle-like human with mass m is sliding around in circles at speed v . The equation describing the bowl is $z = CR^2 = C(x^2 + y^2)$.

- Find v in terms of any or all of R , g , and C .
- Now say you are given ω , C and g . Find v and R if you can. Explain any oddities.



problem 8.31: (Filename:p.f96.p2.1)

8.32 Mass on a rotating inclined platform. A block of mass $m = 5$ kg is held on an inclined platform by a rod BC as shown in the figure. The platform rotates at a constant angular rate ω . The coefficient of friction between the block and the platform is μ . $\theta = 30^\circ$, $L = 1$ m, and $g = 9.81$ m/s². (a) Assuming $\omega = 5$ rad/s and $\mu = 0$ find the tension in the rod. (b) If $\mu = .3$ what is the range of ω for which the block would stay on the ramp without slipping even if there were no rod? *

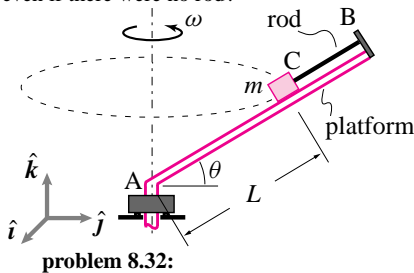

problem 8.32: (Filename:pfigure.s94h5p6)

8.33 A circular plate of radius $r = 10$ cm rotates in the horizontal plane about the vertical axis passing through its center O . Two identical point masses hang from two points on the plate diametrically opposite to each other as shown in the figure. At a constant angular speed ω , the two masses maintain a steady state angle θ from their vertical static equilibrium.

- Find the linear speed and the magnitude of the centripetal acceleration of either of the two masses.

- Find the steady state ω as a function of θ . Do the limiting values of θ , $\theta \rightarrow 0$ and $\theta \rightarrow \pi/2$ give sensible values of ω ?

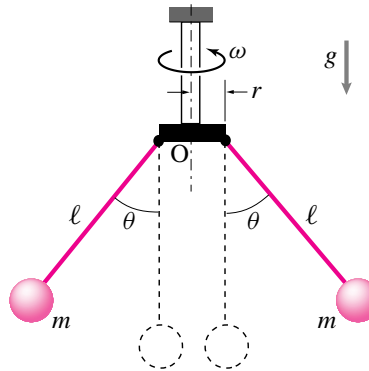

problem 8.33: (Filename:pfigure4.2.rp6)

8.34 For the rod and mass system shown in the figure, assume that $\theta = 60^\circ$, $\omega \equiv \dot{\theta} = 5$ rad/s, and $\ell = 1$ m. Find the acceleration of mass B at the instant shown by

- calculating $\vec{a} = \vec{\omega} \times \vec{\omega} \times \vec{r}$ where \vec{r} is the position vector of point B with respect to point O , i.e., $\vec{r} = \vec{r}_{B/O}$, and by
- calculating $\vec{a} = -R\dot{\theta}^2\hat{e}_R$ where R is the radius of the circular path of mass B .

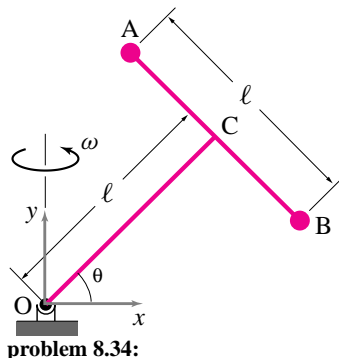

problem 8.34: (Filename:pfigure4.2.rp7)

8.35 A spring of relaxed length ℓ_0 (same as the diameter of the plate) is attached to the mid point of the rods supporting the two hanging masses.

- Find the steady angle θ as a function of the plate's rotation rate ω and the spring constant k . (Your answer may include other given constants.)
- Verify that, for $k = 0$, your answer for θ reduces to that in problem 8.33.
- Assume that the entire system sits inside a cylinder of radius 20 cm and the axis of rotation is aligned with the longitudinal axis of the cylinder. The maximum operating speed of the rotating shaft is 200 rpm (i.e., $\omega_{max} = 200$ rpm). If the two masses are not to touch the walls of the cylinder, find the required spring stiffness k .

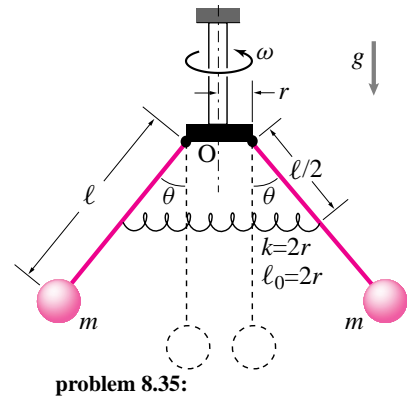

problem 8.35: (Filename:pfigure4.2.rp8)

8.36 Flyball governors are used to control the flow of working fluid in steam engines, diesel engines, steam turbines, etc. A spring-loaded flyball governor is shown schematically in the figure. As the governor rotates about the vertical axis, the two masses tend to move outwards. The rigid and massless links that connect the outer arms to the collar, in turn, try to lift the central collar (mass $m/4$) against the spring. The central collar can move along the vertical axis but the top of the governor remains fixed. The mass of each ball is $m = 5$ kg, and the length of each link is $\ell = 0.25$ m. There are frictionless hinges at points A, B, C, D, E, F where the links are connected. Find the amount the string is elongated, Δx , when the governor rotates at 100 rpm, given that the spring constant $k = 500$ N/m, and that in this steady state, $\theta = 90^\circ$. *

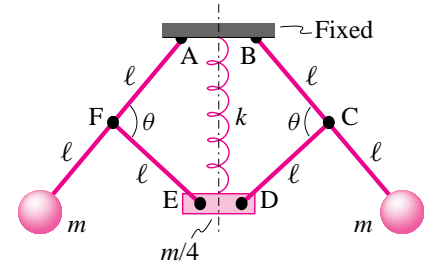

problem 8.36: (Filename:summer95p2.2)

8.37 Crooked rod. A 2ℓ long uniform rod of mass m is welded at its center to a shaft at an angle ϕ as shown. The shaft is supported by bearings at its ends and spins at a constant rate ω .

- What are \vec{H}_O and \vec{L} ?
- Calculate $\dot{\vec{H}}_O$ using the integral definition of angular momentum. *
- What are the six reaction components if there is no gravity? *
- Repeat the calculations, including gravity g . Which reactions change and by how much? *

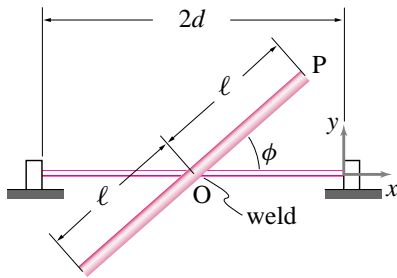

problem 8.37:

(Filename:h6.4)

8.38 For the configuration in problem 8.37, find two positions along the rod where concentrating one-half the mass at each of these positions gives the same \vec{H}_O .

8.39 Rod on a shaft. A uniform rod is welded to a shaft which is connected to frictionless bearings. The rod has mass m and length ℓ and is attached at an angle γ at its midpoint to the midpoint of the shaft. The length of the shaft is $2d$. A motor applies a torque M_{motor} along the axis of the shaft. At the instant shown in the figure, assume m, ℓ, d, ω and M_{motor} are known and the rod lies in the yz -plane.

- Find the angular acceleration of the shaft.
- The moment that the shaft applies to the rod.
- The reaction forces at the bearings.

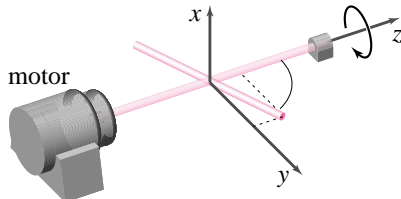

problem 8.39: Rod on a shaft.

(Filename:pg79.2)

8.40 Rod spins on a shaft. A uniform rod \mathcal{R} with length R and mass m spins at constant rate ω about the z axis. It is held by a hinge at A and a string at B. Neglect gravity. Find the tension in the string in terms of ω, R and m . *

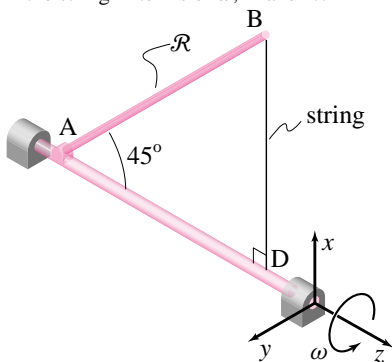

problem 8.40:

(Filename:pfigure.s95f4)

8.41 A uniform narrow shaft of length $2L$ and mass $2M$ is bent at an angle θ half way down its length. It is spun at constant rate ω .

- What is the magnitude of the force that must be applied at O to keep the shaft spinning?
- (harder) What is the magnitude of the moment that must be applied at O to keep the shaft spinning?

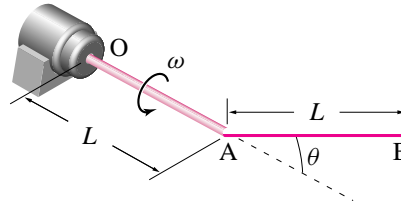

problem 8.41: Spinning rod. No gravity.

(Filename:f.4)

8.42 For the configuration in problem 8.41, find two positions along the bent portion of the shaft where concentrating one-half its mass at each of these positions gives the same \vec{H}_O and \vec{L} .

8.43 Rod attached to a shaft. A uniform $1 \text{ kg}, \sqrt{2} \text{ m}$ rod is attached to a shaft which spins at a constant rate of 1 rad/s . One end of the rod is connected to the shaft by a ball-and-socket joint. The other end is held by two strings (or pin jointed rods) that are connected to a rigid cross bar. The cross bar is welded to the main shaft. Ignore gravity.

- Draw a free body diagram of the rod AB, including a bit of the strings.
- Find the tension in the string DB. Two approaches:
 - Write the six equations of linear and angular momentum balance (about any point of your choosing) and solve them (perhaps using a computer) for the tension T_{DB} .
 - Write the equation of angular momentum balance about the axis AE. (That is, take the equation of angular momentum balance about point A and dot both sides with a vector in the direction of $\mathbf{r}_{E/A}$.) Use this calculation to find T_{DB} and compare to method ii.

- Find the reaction force (a vector) at A.

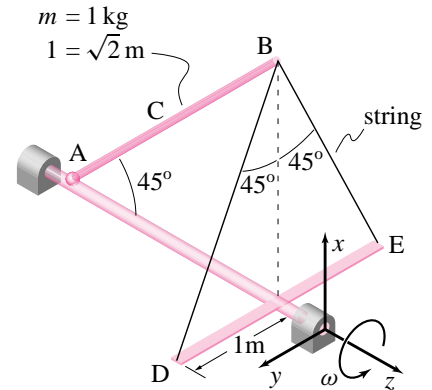

problem 8.43: Uniform rod attached to a shaft.

(Filename:pg89.1)

8.44 3D, crooked bar on shaft falls down. A massless, rigid shaft is connected to frictionless hinges at A and B. A bar with mass M_b and length ℓ is welded to the shaft at 45° . At time $t = 0$ the assembly is tipped a small angle θ_0 from the yz -plane but has no angular velocity. It then falls under the action of gravity. What is θ at $t = t_1$ (assuming t_1 is small enough so that θ_1 is much less than 1)?

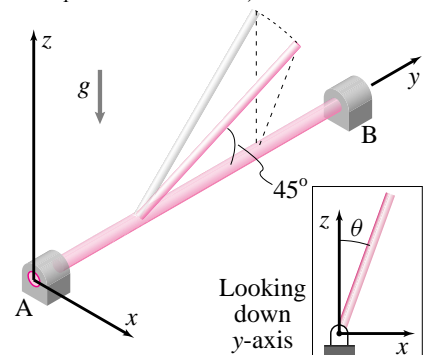

problem 8.44: A crooked rod welded to a shaft falls down.

(Filename:p2.4)

8.3 Moment of inertia matrices: $[I^{cm}]$ and $[I^O]$

8.45 Find the moment of inertia matrix $[I^O]$ of the system shown in the figure, given that $m = 0.25 \text{ kg}$ and $\ell = 0.5 \text{ m}$. Which components in the matrix $[I^O]$ will change if one mass is removed and the other one is doubled?

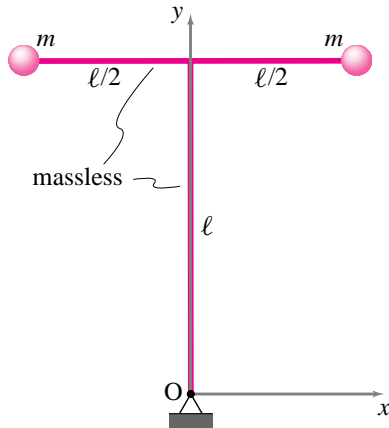

problem 8.45:

(Filename:pfigure4.4.rp12)

8.46 A dumbbell (two masses connected by a massless rod of length ℓ) lies in the xy plane. Compute the moments and products of inertia of this body about the x , y , and z axes. What are the principal axes of this body?

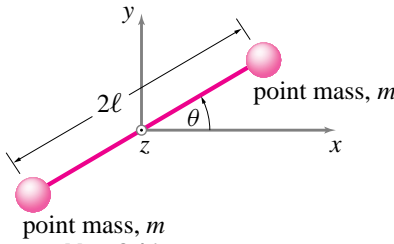

problem 8.46:

(Filename:pfigure.blue.38.2)

8.47 **Equivalent dumbbell.** It is a great fact that, for the purposes of dynamics, every rigid body can be replaced by a massless rigid structure holding six masses. The structure looks like a child's jack. It has three orthogonal bars with three pairs of point masses along the bars. The center of the jack is at the center of mass. The bars are in the directions of the eigenvectors of the moment of inertia matrix of the body (the principal directions). For flat objects one only needs four point masses. Where should one put four masses on a massless disk to make it equivalent to a uniform and 'massful' disk in problem 8.50(a). That is, what set of four masses has the same total mass, the same center of mass location, and the same moment of inertia matrix as a uniform disk?

8.48 Three identical solid spheres of mass m and radius r are situated at $(b, 0, 0)$, $(0, b, b)$, and $(-b, 0, 2b)$ relative to the origin O . Find all nine components of $[I^O]$ of the system of three spheres.

Hint: $[I^{cm}]$ for each sphere is

$$\begin{bmatrix} \frac{2}{5}mr^2 & 0 & 0 \\ 0 & \frac{2}{5}mr^2 & 0 \\ 0 & 0 & \frac{2}{5}mr^2 \end{bmatrix}.$$

Use the parallel axis theorem.

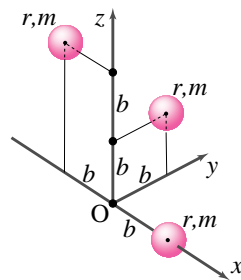

problem 8.48:

(Filename:pfigure.blue.49.2)

8.49 Find the moment of inertia matrix $[I^O]$ for the 'L'-shaped rod shown in the figure. The mass of the rod is $m = 1.5$ kg and each leg is $\ell = 0.4$ m long. You may ignore the width of the rod.

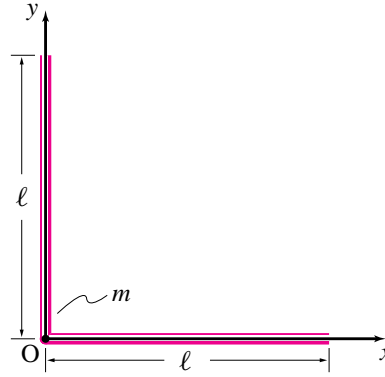

problem 8.49:

(Filename:pfigure4.4.rp13)

8.50 **Moment of Inertia Matrix.** This problem concerns a uniform flat disk of radius R_0 with mass $M_d = M_{disc}$. In the two parts of this problem, you are to calculate the moment of inertia matrix for the disk. In the first part, do it by direct integration and, in the second part, by using a change of basis.

a) Using a coordinate system that is lined up with the disk so that the z axis is normal to the disk and the origin of the coordinate system is at the center of mass (the center) of the disk, calculate the moment of inertia matrix for the disk. [Hint: use polar coordinates, and use $dm = (M/\pi R_0^2) dA$, and $dA = R dR d\theta$.]

b) Use a coordinate system $x'y'z'$ aligned as follows: the origin of the coordinate system is at the center of the disk, the z' axis makes an angle ϕ with the z axis which is normal to the plane of the (measured from the z axis towards the z' axis), the disk intersects the $x'y'$ plane along the y' axis. The y axis and the y' axis are coincident. Calculate the moment of inertia matrix for the disk. Alternate method: use the solution from (a) above with a change of basis.

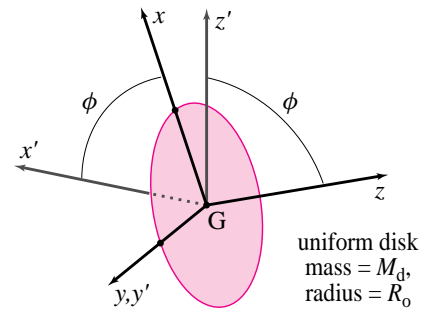

problem 8.50:

(Filename:f92h7p1)

8.51 For each of the shapes below, mark the approximate location of the center of mass and the principal axes about the center of mass

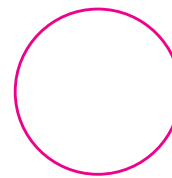

homogeneous sphere

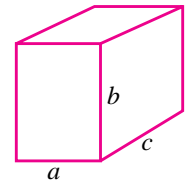

homogeneous rectangular parallelepiped

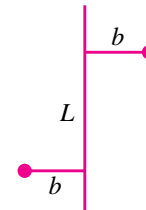

massless rod holding two equal masses

problem 8.51:

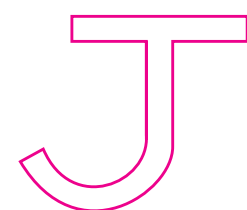

capital "J"

(Filename:pfigure.blue.52.2)

8.52 Find the moment of inertia matrix $[I^{cm}]$ for the uniform solid cylinder of length ℓ and radius r shown in the figure.

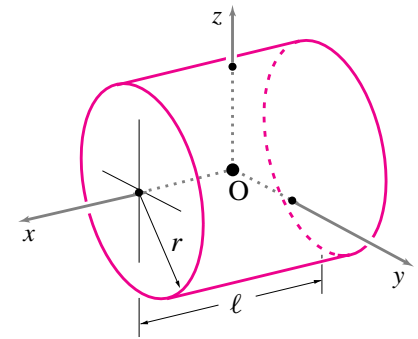

problem 8.52:

(Filename:pfigure4.4.rp16)

8.53 An 'L'-shaped structure consists of two thin uniform rectangular plates each of width $w = 200$ mm. The vertical plate has height

$h = 400$ mm and the horizontal plate has depth $d = 300$ mm. The plates are welded at right angles along the side measuring 200 mm. The total mass of the structure is $m = 0.7$ kg. Find the moment of inertia matrix $[I^O]$.

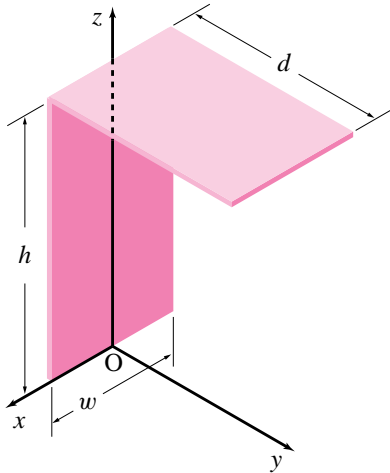

problem 8.53:

(Filename: pfigure4.4.rp14)

8.54 A solar panel consists of three rectangular plates each of mass $m = 1.2$ kg, length $\ell = 1$ and width $w = 0.5$ m. The two side panels are inclined at 30° with the plane of the middle panel. Evaluate all components of the moment of inertia matrix $[I^O]$ of the solar panel.

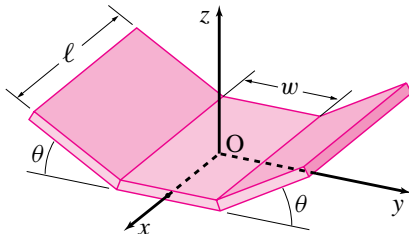

problem 8.54:

(Filename: pfigure4.4.rp15)

8.4 Mechanics using $[I^{cm}]$ and $[I^O]$

8.55 Find the angle between $\vec{\omega}$ and $\vec{H} = [I^G]\vec{\omega}$, if $\vec{\omega} = 3 \text{ rad/s} \hat{k}$ and

$$[I^G] = \begin{bmatrix} 20 & 0 & 0 \\ 0 & 20 & 0 \\ 0 & 0 & 40 \end{bmatrix} \text{ kg} \cdot \text{m}^2.$$

8.56 Find the projection of $\vec{H} = [I^G]\vec{\omega}$ in the direction of $\vec{\omega}$, if $\vec{\omega} = (2\hat{i} - 3\hat{j}) \text{ rad/s}$ and

$$[I^G] = \begin{bmatrix} 5.4 & 0 & 0 \\ 0 & 5.4 & 0 \\ 0 & 0 & 10.8 \end{bmatrix} \text{ lbm ft}^2.$$

8.57 Compute $\vec{\omega} \times ([I^G] \cdot \vec{\omega})$ for the following two cases. In each case $\vec{\omega} = 2.5 \text{ rad/s} \hat{j}$.

a) $[I^G] = \begin{bmatrix} 8 & 0 & 0 \\ 0 & 16 & 0 \\ 0 & 0 & 8 \end{bmatrix} \text{ kg m}^2$, and

*

b) $[I^G] = \begin{bmatrix} 8 & 0 & 0 \\ 0 & 16 & -4 \\ 0 & -4 & 8 \end{bmatrix} \text{ kg m}^2$. *

8.58 Find the z component of $\vec{H} = [I^G]\vec{\omega}$ for $\vec{\omega} = 2 \text{ rad/s} \hat{k}$ and

$$[I^G] = \begin{bmatrix} 10.20 & -2.56 & 0 \\ -2.56 & 10.20 & 0 \\ 0 & 0 & 14.00 \end{bmatrix} \text{ lbm ft}^2.$$

8.59 For $\vec{\omega} = 5 \text{ rad/s} \hat{\lambda}$, find $\hat{\lambda}$ such that the angle between $\vec{\omega}$ and $\vec{H} = [I^G] \cdot \vec{\omega}$ is zero if

$$[I^G] = \begin{bmatrix} 3 & 0 & 2 \\ 0 & 6 & 0 \\ 2 & 0 & 3 \end{bmatrix} \text{ kg m}^2.$$

8.60 Calculation of \vec{H}_O and $\dot{\vec{H}}_O$. You will consider a disc spinning about various axes through the center of the disc O . For the most part, you are concerned with calculating $\dot{\vec{H}}_O$. But, you should keep in mind that the purpose of the calculation might be to calculate reaction forces and moments. Every point on the disk moves in circles about the same axis at the same number of radians per second. These problems can be done at least three different ways: using the $[I]$'s from problem 8.50, direct integration of the definition of $\dot{\vec{H}}_O$, and using the equivalent dumbbell (with the definition of $\dot{\vec{H}}_O$). You should do them all three ways, first using the way you are most comfortable with.

- Assume that the configuration is as in problem 8.50(a) and that the disk is spinning about the z axis at the constant rate of $\omega \hat{k}$. What are \vec{H}_O and $\dot{\vec{H}}_O$?
- Assume that the configuration is as in problem 8.50(b) and that the disk is spinning about the z axis at the constant rate of $\omega \hat{k}$. What are \vec{H}_O and $\dot{\vec{H}}_O$? (In this problem there are two ways to use $[I]$: one is in the xyz coordinate system, the other is in a coordinate system aligned nicely with the disk.)

8.61 What is the angular momentum \vec{H} for:

- A uniform sphere rotating with angular velocity $\vec{\omega}$ (radius R , mass m)?
- A rod shown in the figure rotating about its center of mass with these angular velocities: $\vec{\omega} = \omega \hat{i}$, $\vec{\omega} = \omega \hat{j}$, and $\vec{\omega} = \omega(\hat{i} + \hat{j})/\sqrt{2}$?

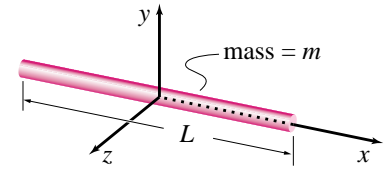

problem 8.61:

(Filename: pfigure.blue.99.1)

8.62 A hoop is welded to a long rigid massless shaft which lies on a diameter of the hoop. The shaft is parallel to the x -axis. At the moment of interest the hoop is in the xy -plane of a coordinate system which has its origin O at the center of the hoop. The hoop spins about the x -axis at 1 rad/s . There is no gravity.

- What is $[I_G]$ of the hoop?
- What is \vec{H}_O of the hoop?

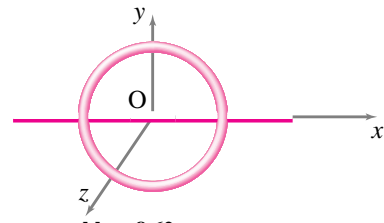

problem 8.62:

(Filename: pfigure.blue.47.2)

8.63 Two thin rods, each of mass m and length d , are welded perpendicularly to an axle of mass M and length ℓ , which is supported by a ball-and-socket joint at A and a journal bearing at B . A force $\vec{F} = -F\hat{i} + G\hat{k}$ acts at the point P as shown in the figure. Determine the initial angular acceleration α and initial reactions at point B .

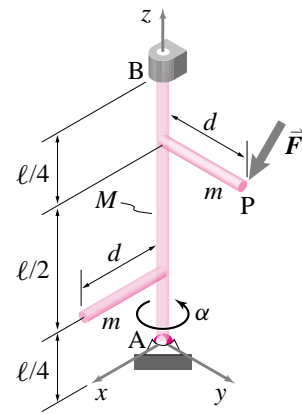

problem 8.63:

(Filename: pfigure.blue.89.1)

8.64 The thin square plate of mass M and side c is mounted vertically on a vertical shaft which rotates with angular speed ω_0 . In the fixed x, y, z coordinate system with origin at the center of mass (with which the plate is currently aligned) what are the vector components of $\vec{\omega}$? What are the components of \vec{H}_{cm} ?

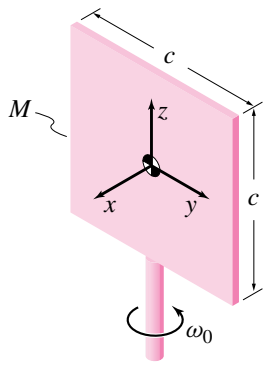

problem 8.64:

(Filename: pfigure.blue.35.2)

8.65 If you take any rigid body (with weight), skewer it with an axle, hold the axle with hinges that cause no moment about the axle, and hold it so that it cannot slide along the axle, it will swing like a pendulum. That is, it will obey the equations:

$$\ddot{\theta} = -C \sin \theta, \quad \text{or} \quad (a)$$

$$\ddot{\phi} = +C \sin \phi, \quad (b)$$

where

θ is the amount of rotation about the axis measuring zero when the center of mass is directly below the z' -axis; i. e., when the center of mass is in a plane containing the z' -axis and the gravity vector,

ϕ is the amount of rotation about the axis measuring zero when the center of mass is directly above the z' -axis,

$$C = M_{total} g d \sin \gamma / I_{z'z'}$$

M_{total} is the total mass of the body,

g is the gravitational constant,

d is the perpendicular distance from the axis to the center of mass of the object,

γ is the angle of tip of the axis from the vertical,

$I_{z'z'}$ is the moment of inertia of the object about the skewer axis.

- How many examples of such pendula can you think of and what would be the values of the constants? (e.g. a simple pendulum?, a broom upside down on your hand?, a door?, a box tipping on one edge?, a bicyclist stopped at a red light and stuck in her new toe clips?, a person who got *rigor mortis* and whose ankles went totally limp at the same time?....)
- A door with frictionless hinges is misaligned by half an inch (the top hinge is half an inch away from the vertical line above the other hinge). Estimate the period with which it will swing back and forth. Use reasonable magnitudes of any quantities you need.

c) Can you verify the formula (a simple pendulum and a swinging stick are special cases)?

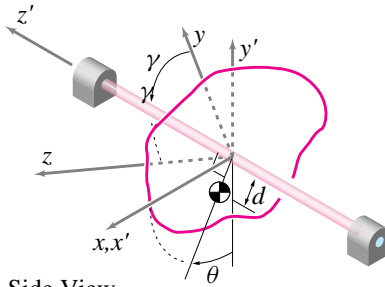

Side View

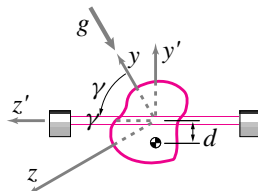

problem 8.65: 3-D pendulum on a hinge.

(Filename: pfigure4.3Dpend)

8.66 A hanging rod going in circles. A uniform rod with length ℓ and mass m hangs from a well greased ball and socket joint at O . It swings in circles at constant rate $\vec{\omega} = \omega \hat{k}$ while the rod makes an angle ϕ with the vertical (so it sweeps a cone).

- Calculate \vec{H}_O and $\dot{\vec{H}}_O$.
- Using \vec{H}_O and angular momentum balance, find the rotation rate ω in terms of ϕ , g , ℓ , and m . How long does it take to make one revolution? *
- If another stick rotates twice as fast while making the same angle ϕ , what must be its length compared to ℓ ?
- Is there a simple way to describe what two uniform sticks of different length and different cone angle ϕ both have in common if their rate of rotation ω is the same? (If you accurately draw two such sticks, you should see the relation.)
- Find the reaction force at the ball and socket joint. Is this force parallel to the stick?

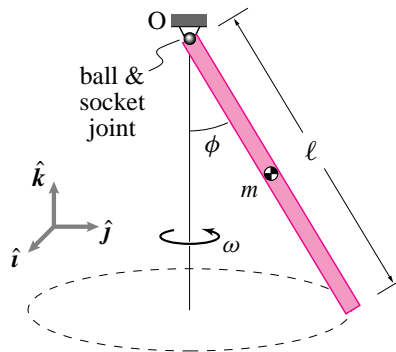

problem 8.66:

(Filename: pfigure.s94h6p3)

8.67 From discrete to continuous. n equal beads of mass m/n each are glued to a rigid massless rod at equal distances $l = L/n$ from each other. For $n = 4$, the system is shown in the figure, but you are to consider the general problem with n masses. The rod swings around the vertical axis maintaining angle ϕ .

- Find the rate of rotation of the system as a function of g , L , n , and ϕ for constant rate circular motion. [Hint: You may need these series sums: $1 + 2 + 3 + \dots + n = \frac{n(n+1)}{2}$ and $1^2 + 2^2 + 3^2 + \dots + n^2 = \frac{n(n+1)(2n+1)}{6}$.] *
- Set $n = 1$ in the expression derived in (a) and check the value with the rate of rotation of a conical pendulum of mass m and length ℓ .
- Now, put $n \rightarrow \infty$ in the expression obtained in part (a). Does this rate of rotation make sense to you? [Hint: How does it compare with the rate of rotation for the uniform stick of Problem 8.66?]

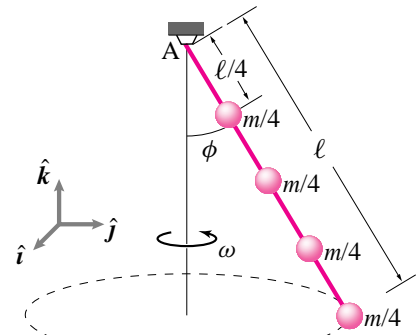

problem 8.67:

(Filename: pfigure.s94h6p4)

8.68 Spinning dumbbell. Two point masses are connected by a rigid rod of negligible mass and length $2\sqrt{2}L$. The rod is welded to a shaft that is along the y axis. The shaft is spinning at a constant rate ω driven by a motor at A (Not shown). At the time of interest the dumbbell is in the yz -plane. Neglect gravity.

- What is the moment of inertia matrix about point O for the dumbbell at the instant shown? *
- What is the angular momentum of the dumbbell at the instant shown about point O . *
- What is the rate of change of angular momentum of the dumbbell at the instant shown? Calculate the rate of change of angular momentum two different ways:
 - by adding up the contribution of both of the masses to the rate of change of angular momentum (i.e. $\dot{\vec{H}} = \sum \vec{r}_i \times (m_i \vec{a}_i)$) and
 - by calculating I_{xy} and I_{yz} , calculating \vec{H} , and then calculating $\dot{\vec{H}}$ from $\vec{\omega} \times \vec{H}$. *

d) What is the total force and moment (at the CM of the dumbbell) required to keep this motion going? Do the calculation in the following ways:

- (i) Using angular momentum balance (about any point of your choice) for the shaft-dumbbell system.
- (ii) By drawing free body diagrams of the masses alone and calculating the forces on the masses. Then use action and reaction and draw a free body diagram of the remaining (massless) part of the shaft-dumbbell system. Then use moment balance for this system. *

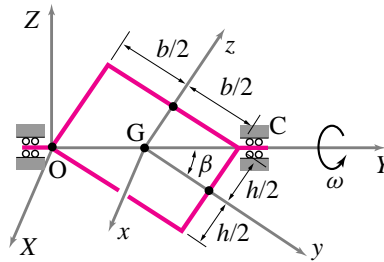

OXYZ - Fixed Frame
(base vectors, $\hat{i}, \hat{j}, \hat{k}$)

Gxyz - Moving "Body" Frame
(base vectors, $\hat{e}_x, \hat{e}_y, \hat{e}_z$)

problem 8.69:

(Filename: pfigure.blue.36.1)

8.70 A uniform rectangular plate spins about a fixed axis. The constant torque M_y is applied about the Y axis. The plate is held by bearings at the corners of the plate at A and B. At the instant shown the plate and the $y'z'$ axis attached to the plate are in the YZ plane. Neglect gravity. At $t = 0$ the plate is at rest.

- a) At $t = 0^+$ (i.e., just after the start), what is the acceleration of point D? Give your answer in terms of any or all of $c, d, m, M_y, \hat{i}, \hat{j}$, and \hat{k} (the base vectors aligned with the fixed XYZ axes), and I_{YY}^{cm} . [You may use I_{YY}^{cm} in your answer. Or you could use this result from the change of coordinates formulae in linear algebra: $I_{YY}^{cm} = (\cos^2 \beta) I_{y'y'}^{cm} + (\sin^2 \beta) I_{z'z'}^{cm}$ to get an answer in terms of c, d, m , and M_y .]
- b) At $t = 0^+$, what is the reaction at B? *

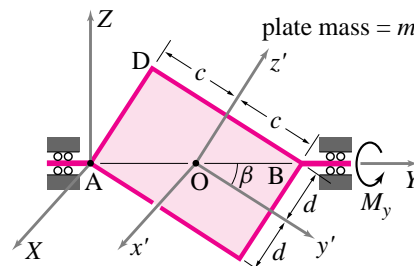

problem 8.70:

(Filename: pfigure.s95q8)

8.71 A uniform semi-circular disk of radius $r = 0.2$ m and mass $m = 1.5$ kg is attached to a shaft along its straight edge. The shaft is tipped slightly from a vertical upright position. Find the dynamic reactions on the bearings supporting the shaft when the disk is in the vertical plane (xz) and below the shaft.

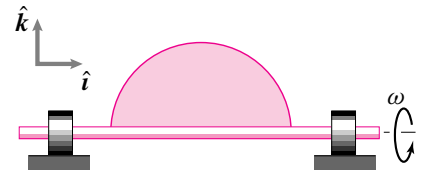

problem 8.71:

(Filename: pfigure4.rpi)

8.72 A thin triangular plate of base b , height h , and mass m is attached to a massless shaft which passes through the bearings L and R. The plate is initially vertical and then, provoked by a teensy disturbance, falls, pivoting around the shaft. The bearings are frictionless. Given,

$$\begin{aligned} \vec{r}_{cm} &= (0, \frac{2}{3}b, \frac{1}{3}h), \\ I_{xx}^O &= \frac{m}{2}(b^2 + h^2/3), \\ I_{yy}^O &= mh^2/6, \\ I_{zz}^O &= mb^2/2, \\ I_{yy}^{cm} &= mh^2/18, \\ I_{zy}^O &= -mbh/4, \end{aligned}$$

- a) what is the plate's angular velocity as it passes through the downward vertical position?
- b) Compute the bearing reactions when the plate swings through the downward vertical position.

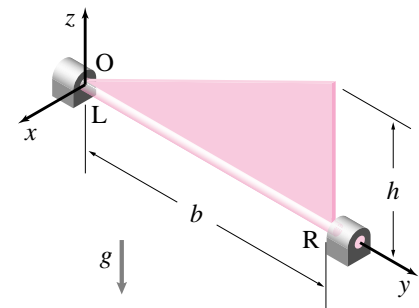

problem 8.72:

(Filename: pfigure.blue.86.1)

8.73 A welded structural tubing framework is proposed to support a heavy emergency searchlight. To select properly the tubing dimensions it is necessary to know the forces and moments at the critical section AA, when the framework is moving. The frame moves as shown.

- a) Determine the magnitude and direction of the dynamic moments (bending and twisting) and forces (axial and shear) at section AA of the frame if, at the instant shown, the frame has angular velocity ω_o and angular acceleration α_o . Assume that the mass per unit length of the pipe is ρ .

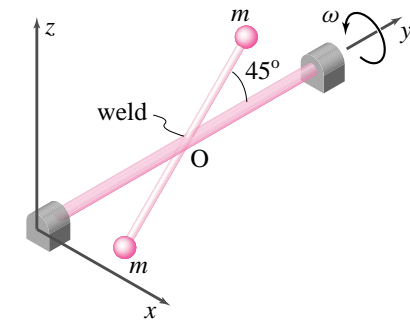

Looking down x-axis

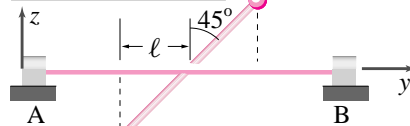

problem 8.68: Crooked spinning dumbbell.

(Filename: pg84.3)

8.69 A uniform rectangular plate of mass m , height h , and width b spins about its diagonal at a constant angular speed ω , as shown in the figure. The plate is supported by frictionless bearings at O and C. The plate lies in the YZ-plane at the instant shown.

(Note: $\frac{\cos(\beta)}{b/\sqrt{(h^2 + b^2)}, \sin(\beta) = h/\sqrt{(h^2 + b^2)}}$ =

- a) Compute the angular momentum of the plate about G (with respect to the body axis Gxyz shown).
- b) Ignoring gravity determine the net torque (moment) that the supports impose on the body at the instant shown. (Express your solution using base vectors and components associated with the inertial XYZ frame.)
- c) Calculate the reactions at O or C for the configuration shown. *
- d) In the case when $h = b = 1$ m what is the vertical reaction at C (still neglecting gravity).

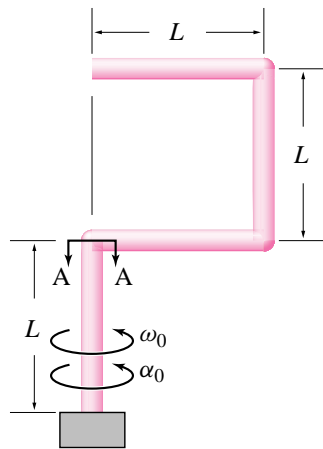

problem 8.73:

(Filename:pfigure.blue.88.1)

8.74 A uniform cube with side 0.25 m is glued to a pipe along the diagonal of one of its faces $ABCD$. The pipe rotates about the y -axis at a constant rate $\omega = 30$ rpm. At the instant of interest, the face $ABCD$ is in the xy -plane.

- Find the velocity and acceleration of point F on the cube.
- Find the position of the center of mass of the cube and compute its acceleration \vec{a}_{cm} .
- Suppose that the entire mass of the cube is concentrated at its center of mass. What is the angular momentum of the cube about point A ?

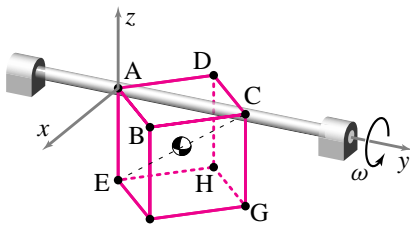

problem 8.74:

(Filename:pfigure4.2.rp3)

8.75 A uniform square plate of mass m and side length b is welded to a narrow shaft at one corner. The shaft is perpendicular to the plate and has length ℓ . The upper end of the shaft is connected to a ball and socket joint at O . The assembly is rotating about the z axis through O at the fixed rate $\vec{\omega} = \omega \hat{k}$ which happens to be just right to make the plate horizontal and the shaft vertical, as shown. The gravitational constant is g .

- What is ω in terms of m , ℓ , b , and g ?
- Is the reaction at O on the rod-plate assembly in the direction of the line from G to O ? (Why?)

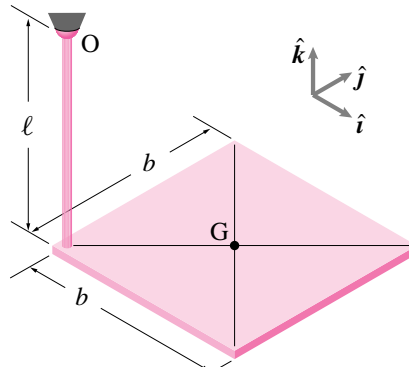

problem 8.75:

(Filename:pfigure.s94q6p1)

8.76 A spinning box. A solid box \mathcal{B} with dimensions a , a , and $2a$ (where $a = .1$ m) and mass = 1 kg. It is supported with ball and socket joints at opposite diagonal corners at A and B . It is spinning at constant rate of $(50/\pi)$ rev/sec and at the instant of interest is aligned with the fixed axis \hat{i} , \hat{j} , and \hat{k} . Neglect gravity.

- What is $\vec{\omega}_{\mathcal{B}}$?
- What is $\dot{\vec{\omega}}_{\mathcal{B}}$?
- What is $\vec{H}_{\mathcal{B}/cm}$?
- What is $\dot{\vec{H}}_{\mathcal{B}/cm}$?
- What is $\vec{r}_{B/A} \times \vec{F}_B$ (where \vec{F}_B is the reaction force on \mathcal{B} at B)? A dimensional vector is desired.
- If the hinges were suddenly cut off when \mathcal{B} was in the configuration shown, what would be $\dot{\vec{\omega}}_{\mathcal{B}}$ immediately afterwards?

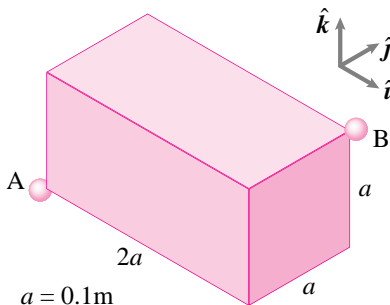

problem 8.76:

(Filename:pfigure.s94f1p2)

8.77 Uniform rod attached to a shaft. A uniform 1 kg, $\sqrt{2}$ m rod is attached to a shaft which spins at a constant rate of 1 rad/s. One end of the rod is connected to the shaft by a ball-and-socket joint. The other end is held by two strings (or pin jointed rods) that are connected to a rigid cross bar. The cross bar is welded to the main shaft. Ignore gravity. Find the reaction force at A .

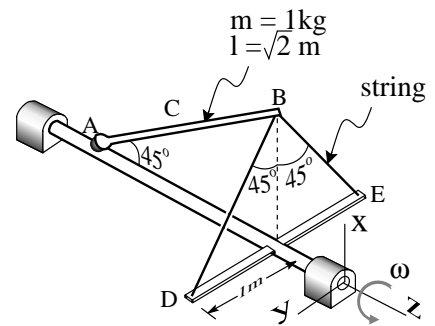

problem 8.77:

(Filename:s97f2)

8.78 A round disk spins crookedly on a shaft. A thin homogeneous disk of mass m and radius r is welded to the horizontal axle AB . The normal to the plane of the disk forms an angle β with the axle. The shaft rotates at the constant rate ω .

- What is the x component of the angular momentum of the disk about point G the center of mass of the disk?
- What is the x component of the rate of change of angular momentum of the disk about G ?
- At the given instant, what is the total force and moment (about G) required to keep the disk spinning at constant rate?

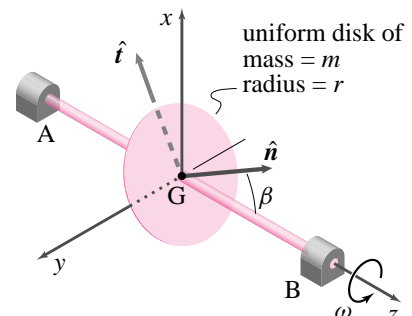

problem 8.78: A round disk spins crookedly on a shaft.

(Filename:pg92.2)

8.79 A uniform disk of mass $m = 2$ kg and radius $r = 0.2$ m is mounted rigidly on a massless axle. The normal to the disk makes an angle $\beta = 60^\circ$ with the axle. The axle rotates at a constant rate $\omega = 60$ rpm. At the instant shown in the figure,

- Find the angular momentum \vec{H}_O of the disk about point O . *
- Draw the angular momentum vector indicating its magnitude and direction. *
- As the disk rotates (with the axle), the angular momentum vector changes. Does it change in magnitude or direction, or both? *

- d) Find the direction of the net torque on the system at the instant shown. Note, only the *direction* is asked for. You can answer this question based on parts (b) and (c). *

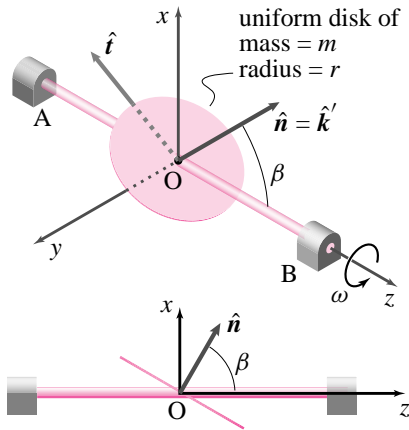

Front View (xz-plane)
problem 8.79:

(Filename:summer95p2.3)

8.80 A uniform disk spins at constant angular velocity. The uniform disk of mass m and radius r spins about the z axis at the constant rate ω . Its normal \hat{n} is inclined from the z axis by the angle β and is in the xz plane at the moment of interest. What is the total force and moment (relative to O) needed to keep this disk spinning at this rate? Answer in terms of m, r, ω, β and any base vectors you need.

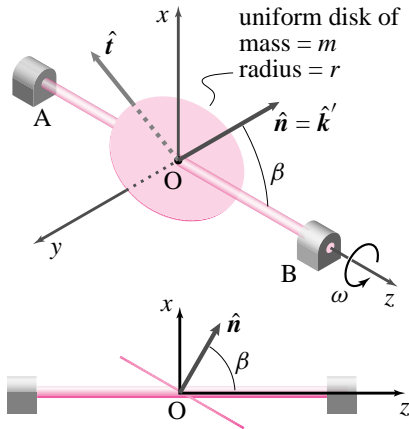

Front View (xz-plane)
problem 8.80:

(Filename:p.f96.p3.3)

8.81 Spinning crooked disk. A rigid uniform disk of mass m and radius R is mounted to a shaft with a hinge. An apparatus not shown keeps the shaft rotating around the z axis at a constant ω . At the instant shown the hinge axis is in the x direction. A massless wire, perpendicular to the shaft, from the shaft at A to the edge of the disk at B keeps the normal to the plate (the z' direction) at an angle ϕ with the shaft.

- a) What is the tension in the wire? Answer in terms of some or all of R, m, ϕ and ω .
b) What is the reaction force at the hinge at O ?

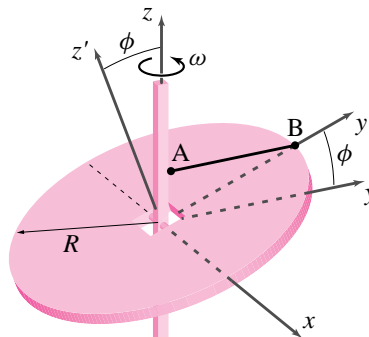

problem 8.81:

(Filename:s97p3.3)

8.82 A disoriented disk rotating with a shaft. A uniform thin circular disk with mass $m = 2$ kg and radius $R = 0.25$ m is mounted on a massless shaft as shown in the figure. The shaft spins at a constant speed $\omega = 3$ rad/s. At the instant shown, the disk is slanted at 30° with the xy -plane. Ignore gravity.

- a) Find the rate of change of angular momentum of the disk about its center of mass. *
b) Find the rate of change of angular momentum about point A . *
c) Find the total force and moment required at the supports to keep the motion going. *

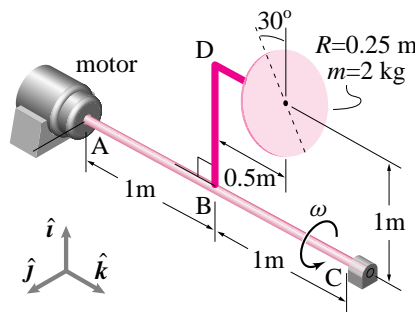

problem 8.82:

(Filename:pfigure.s94h8p1)

8.5 Dynamic balance

8.83 Is $\vec{\omega} = (2\hat{i} + 5\hat{k})$ rad/s an eigenvector of

$$[I^G] = \begin{bmatrix} 8 & 0 & 0 \\ 0 & 16 & -4 \\ 0 & -4 & 8 \end{bmatrix} \text{ kg m}^2?$$

8.84 Find the eigenvalues and eigenvectors of

$$[I^G] = \begin{bmatrix} 5 & 0 & 0 \\ 0 & 5 & -3 \\ 0 & -3 & 10 \end{bmatrix} \text{ kg m}^2.$$

8.85 Three equal length (1 m) massless bars are welded to the rigid shaft AB which spins at constant rate $\vec{\omega} = \omega\hat{i}$. Three equal masses (1 kg) are attached to the ends of the bars. At the moment of interest the masses are all in the xy plane as shown. Where should what masses be added to make the system shown dynamically balanced? [The solution is not unique.]

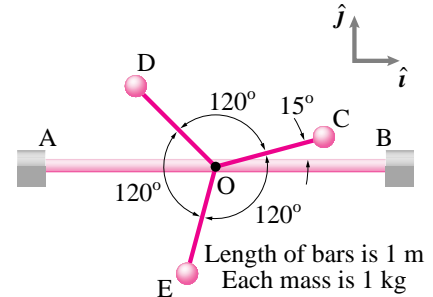

problem 8.85:

(Filename:pfigure.s94q7p1)

8.86 Dynamic balance of a system of particles. Three masses are mounted on a massless shaft AC with the help of massless rigid rods. Mass $m_1 = 1$ kg and mass $m_2 = 1.5$ kg. The shaft rotates with a constant angular velocity $\vec{\omega} = 5$ rad/s \hat{k} . At the instant shown, the three masses are in the xz -plane. Assume frictionless bearings and ignore gravity.

- a) Find the net reaction force (the total of all the forces) on the shaft. Is the system statically balanced?
b) Find the rate of change of angular momentum $\vec{H}_{/A}$, using $\dot{\vec{H}}_{/A} = \sum_i \vec{r}_{i/A} \times m_i \vec{a}_i$.
c) Find the angular momentum about point A , $\vec{H}_{/A}$. Use this intermediate result to find the rate of change of angular momentum $\dot{\vec{H}}_{/A}$, using $\dot{\vec{H}}_{/A} = \vec{\omega} \times \vec{H}_{/A}$ and verify the result obtained in (b).
d) What is the value of the resultant unbalanced torque on the shaft? Propose a design to balance the system by adding an appropriate mass in an appropriate location.

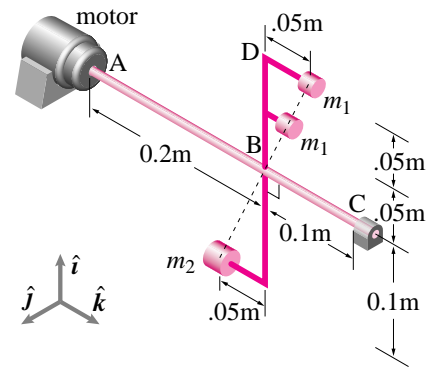

problem 8.86:

(Filename:pfigure.s94h7p2)

8.87 For what orientation of the rod ϕ is the system shown dynamically balanced?

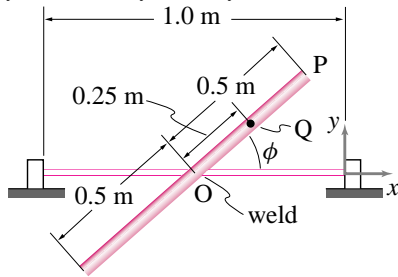

problem 8.87:

(Filename:ch4.7.c)

8.88 A uniform square plate with 1 m sides and 1 kg mass is mounted (as shown) with a shaft that is in the plane of the square but not parallel to the sides. What is the net force and moment required to maintain rotation at a constant rate?

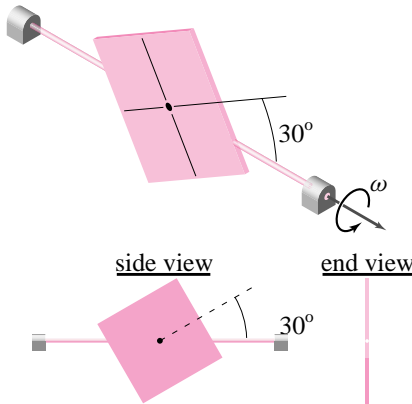

problem 8.88:

(Filename:pfigure.blue.87d.1)

8.89 An equilateral uniform triangular plate with sides of length ℓ plate spins at constant rate ω about an axis through its center of mass. The axis is coplanar with the triangle. The angle ϕ is arbitrary. When $\phi = 0^\circ$, the base of the triangle is parallel to the axis of rotation. Find the net force and moment required to maintain rotation of the plate at a constant rate for any ϕ . For what angle ϕ is the plate dynamically balanced?

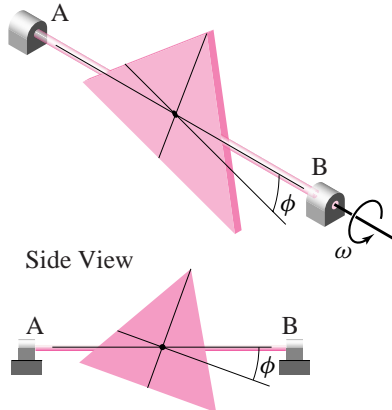

problem 8.89:

(Filename:Mikef91p3)

8.90 An abstract problem. This problem concerns a system rigidly attached to a massless rod spinning about a fixed axis at a fixed rate. That is, whether or not the system is a rigid body, it is moving as if it were a rigid body. Every point in the system is moving in circles about the same axis at the same number of radians per second. The position of a particle of the system relative to the axis is \vec{R} . The position relative to some point C is \vec{r}_C . In all cases, the body rotates about the axis shown. The total mass of all the objects is M_{tot} . Point O is at the center of mass of the system and is at a distance d from the rotation axis and is on the x -axis at the moment of interest. Assume there is no gravity. At the point A, the rod is free to slide in the z -direction. But, at point B, the rod is constrained from moving in the z -direction. The FBD of the system is shown in the figure. Referring to the free body diagram, there are six scalar unknown reactions in this 3 dimensional problem.

- The general case:** Imagine that you know $\vec{H}_O = \dot{H}_{0x}\hat{i} + \dot{H}_{0y}\hat{j} + \dot{H}_{0z}\hat{k}$ and also $\vec{L} = \dot{L}_x\hat{i} + \dot{L}_y\hat{j} + \dot{L}_z\hat{k}$. How would you find the six unknown reactions $A_x, A_y, M_{Az}, B_x, B_y, B_z$? [Reduce the problem to one of solving six equations in six unknowns.]
- The General Result:** Is M_{Az} necessarily equal to zero? Prove your result or find a counter-example. *
- Static Balance:** If $d = 0$ is it true that all reaction forces are equal to zero? Prove your result or find a counter example. *

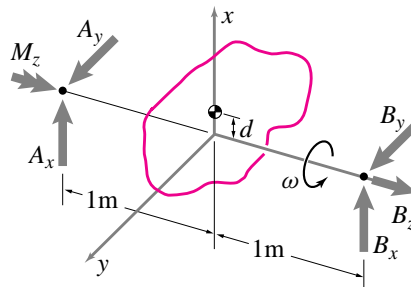

problem 8.90:

(Filename:pfigure.s94h7p3)

8.91 A uniform block spins at constant angular velocity. The magnitude of the angular velocity is ω . The center of mass G is on the axis of rotation. The \hat{i}, \hat{j} , and \hat{k} directions are parallel to the sides with lengths b, c and d , respectively.

Answer in terms of some or all of $\omega, m, b, c, d, \hat{i}, \hat{j}$, and \hat{k} .

- Find \vec{v}_H .
- Find \vec{a}_H .
- What is the sum of all the moments about point G of all the reaction forces at A and B?

- Are there any values of b, c , and d for which this block is dynamically balanced for rotation about an axis through a pair of corners? Why?

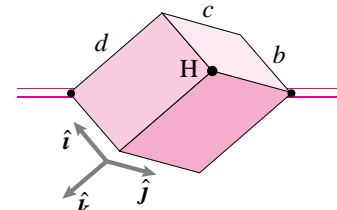

problem 8.91:

(Filename:p.f96.p2.3)

8.92 Dynamic Balance. Consider each of the objects shown in turn (so to speak), each spinning about the z axis which is horizontal. In each case the center of mass is half way between the bearings (not shown). Gravity is in the $-\hat{j}$ direction. State whether it is possible to spin the object at constant rate with constant bearing reactions of $mg\hat{j}/2$ and no other applied torques ('yes') or might not be ('no'). Give a brief explanation of your answer (enough to distinguish an informed answer from a guess).

- Axis along centerline of a uniform rectangular plate.
- Axis orthogonal to uniform rectangular plate and through its centroid.
- Axis orthogonal to uniform rectangular plate and *not* through its centroid.
- Axis orthogonal to uniform but totally irregular shaped plate and through its centroid.
- Axis along the diagonal of a uniform rhombus.
- Axis through the center of a uniform sphere.
- Axis through the diagonal of a uniform cube.
- Axis with two equal masses attached as shown.
- Axis with three equal masses attached as shown, all in a common plane with the axis, with ϕ not equal to 30° .
- An arbitrary rigid body which has center of mass on the axis and two of its moment-of-inertia eigenvectors perpendicular to the axis. (no picture)

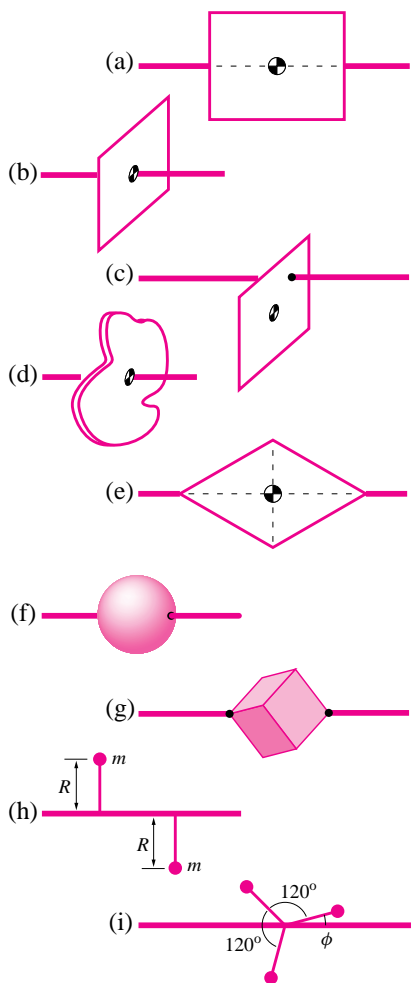

problem 8.92:

(Filename:s97p3.2)

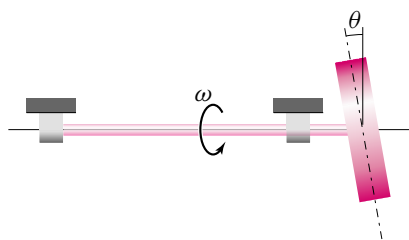

problem 8.93:

(Filename:pfigure.s94h7p5)

8.93 Dynamic tire balancing. Where should you place what weights in order to dynamically balance the tire?

Assume that a car tire can be modeled as a uniform disk of radius one foot and mass 20 lbm. Assume the tire has been mounted crooked by one degree (the plane of the disk makes an 89° angle with the car axle). This crooked wheel is *statically* balanced since its center of mass is on the axis of rotation. But it is dynamically unbalanced since it wobbles and will wobble the car. Car shops put little weights on unbalanced wheels to balance them. They figure out where to put the weights by using a little machine that measures the wheel wobble. But you don't need such a machine for this problem because you have been told where all the mass is located.

There are many approaches to solving this problem and there are also many correct solutions. You should find any correct solution. [one approach: guess a good location to put two masses and then figure out how big they have to be to make the tire dynamically balanced.]

Problems for Chapter 9

General planar motion of particles and rigid bodies

9.1 Kinematics of planar rigid-body motion

9.1 A particle moves along the two paths (1) and (2) as shown.

- In each case, determine the velocity of the particle in terms of b , θ , and $\dot{\theta}$. *
- Find the x and y coordinates of the path as functions of b and r or b and θ . *

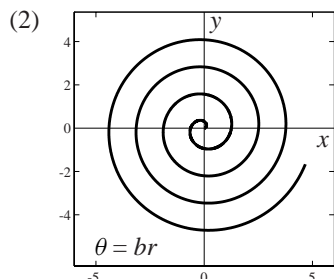
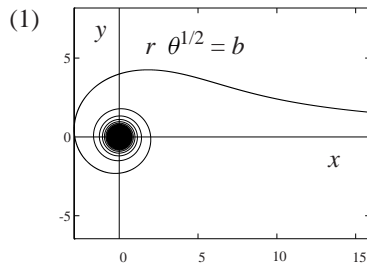

problem 9.1:

(Filename:polarplot0)

9.2 For the particle path (1) in problem 9.1, find the acceleration of the particle in terms of b , θ , and $\dot{\theta}$.

9.3 For the particle path (2) in in problem 9.1, find the acceleration of the particle in terms of b , θ , and $\dot{\theta}$.

9.4 A body moves with constant velocity V in a straight line parallel to and at a distance d from the x -axis.

- Calculate $\dot{\theta}$ in terms of V , d , and θ .
- Calculate the \hat{e}_θ component of acceleration.

Carefully define, using a sketch and/or words, any variables, coordinate systems, and reference frames you use. Express your answers using any convenient coordinate system (just make sure its orientation has been clearly defined).

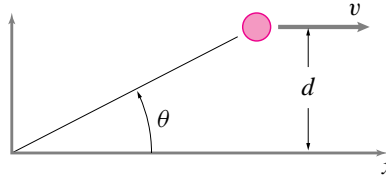

problem 9.4:

(Filename:pfigure.blue.62.1)

9.5 The slender rod AB rests against the step of height h , while end "A" is moved along the ground at a constant velocity v_o . Find $\dot{\phi}$ and $\ddot{\phi}$ in terms of x , h , and v_o . Is $\dot{\phi}$ positive or negative? Is $\ddot{\phi}$ positive or negative?

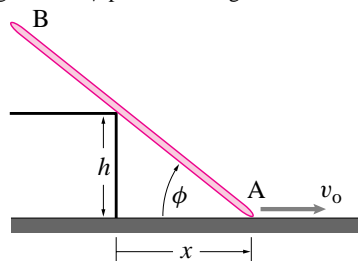

problem 9.5:

(Filename:pfigure.blue.98.1)

9.6 A ten foot ladder is leaning between a floor and a wall. The top of the ladder is sliding down the wall at one foot per second. (The foot is simultaneously sliding out on the floor). When the ladder makes a 45 degree angle with the vertical what is the speed of the midpoint of the ladder?

9.7 A stone in a wheel. A round wheel rolls to the right. At time $t = 0$ it picks up a stone the road. The stone is stuck in the edge of the wheel. You want to know the direction of the rock's motion just before and after it next hits the ground. Here are some candidate answers:

- When the stone approaches the ground its motion is tangent to the ground.
- The stone approaches the ground at angle x (you name it).
- When the stone approaches the ground its motion is perpendicular to the ground.
- The stone approaches the ground at various angles depending on the following conditions(...you list the conditions.)

Although you could address this question analytically, you are to try to get a clear answer by looking at computer generated plots. In particular, you are to plot the pebble's path for a small interval of time near when the stone next touches the ground. You should pick the parameters that make your case for an answer the strongest. You may make more than one plot.

Here are some steps to follow:

- Assuming the wheel has radius R_w and the pebble is a distance R_p from the center (not necessarily equal to R_w). The pebble is directly below the center of the wheel at time $t = 0$. The wheel spins at constant clockwise rate ω . The x -axis is on the ground and $x(t = 0) = 0$. The wheel rolls without slipping. Using a clear well labeled drawing (use a compass and ruler or a computer drawing program), show that

$$x(t) = \omega t R_w - R_p \sin(\omega t)$$

$$y(t) = R_w - R_p \cos(\omega t)$$

- Using this relation, write a program to make a plot of the path of the pebble as the wheel makes a little more than one revolution. Also show the outline of the wheel and the pebble itself at some intermediate time of interest. [Use any software and computer that pleases you.]

- Change whatever you need to change to make a good plot of the pebble's path for a small amount of time as the pebble approaches and leaves the road. Also show the wheel and the pebble at some time in this interval.

- In this configuration the pebble moves a *very* small distance in a small time so your axes need to be scaled. But make sure your x - and y - axes have the same scale so that the path of the pebble and the outline of the wheel will not be distorted.

- How does your computer output buttress your claim that the pebble approaches and leaves the ground at the angles you claim?

- Think of something about the pebble in the wheel that was not explicitly asked in this problem and explain it using the computer, and/or hand calculation and/or a drawing.

9.8 A uniform disk of radius r rolls at a constant rate without slip. A small ball of mass m is attached to the outside edge of the disk. What is the force required to hold the disk in place when the mass is above the center of the disk?

9.9 Rolling at constant rate. See also problem 9.39. A round disk rolls on the ground at constant rate. It rolls $1\frac{1}{4}$ revolutions over the time of interest.

- Particle paths.** Accurately plot the paths of three points: the center of the disk C , a point on the outer edge that is initially on the ground, and a point that is initially half way between the former two points. [Hint: Write a parametric equation for the position of the points. First find a relation between ω and v_C . Then note that the position of a point is the position of the center plus the position of the point relative to the center.] Draw the paths on the computer, make sure x and y scales are the same (In MATLAB, use the axis('equal') command for the same scaling).
- Velocity of points.** Find the velocity of the points at a few instants in the motion: after $\frac{1}{4}$, $\frac{1}{2}$, $\frac{3}{4}$, and 1 revolution. Draw the velocity vector (by hand) on your plot. Draw the direction accurately and draw the lengths of the vectors in proportion to their magnitude. You can find the velocity by differentiating the position vector or by using relative motion formulas appropriately. Draw the disk at its position after one quarter revolution. Note that the velocity of the points is perpendicular to the line connecting the points to the ground contact.
- Acceleration of points.** Do the same as above but for acceleration. Note that the acceleration of the points is parallel to the line connecting the points to the center of the disk.

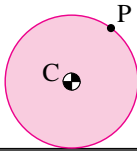

problem 9.9:

(Filename:pfimage.s94h11p2)

9.10 The concentric wheels are welded to each other and roll without slip on the rack and stationary support. The rack moves to the right at $v_r = 1$ m/s. What is the velocity of point A in the middle of the wheels shown?

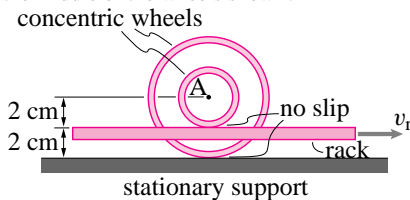

problem 9.10:

(Filename:pfimage.blue.118.1)

9.11 Questions (a) - (e) refer to the cylinders in the configuration shown figure. Question (f) is closely related. Answer the questions in terms

of the given quantities (and any other quantities you define if needed).

- What is the speed (magnitude of velocity) of point c ?
- What is the speed of point P ?
- What is the magnitude of the acceleration of point c ?
- What is the magnitude of the acceleration of point P ?
- What is the radius of curvature of the path of the particle P at the point of interest?
- In the special case of $A = 2b$ what is the curve which particle P traces (for all time)? Sketch the path.

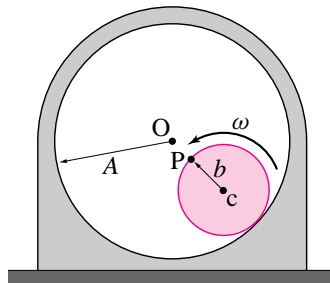

problem 9.11: A little cylinder (with outer radius b and center at point c) rolls without slipping inside a bigger fixed cylinder (with inner radius A and center at point O). The absolute angular velocity of the little cylinder ω is constant. P is attached to the outside edge of the little cylinder. At the instant of interest, P is on the line between O and c .

(Filename:pfimage.blue.50.1)

9.12 See also problems 10.31, 10.35, and 11.28. Arm OC rotates with constant rate ω_1 . Disc D of radius r rotates about point C at constant rate ω_2 measured with respect to the arm OC . What are the absolute velocity and acceleration of point P on the disc, \vec{v}_P and \vec{a}_P ? (To do this problem will require defining a moving frame of reference. More than one choice is possible.) *

- Pick a suitable moving frame and do the problem.
- Pick another suitable moving frame and redo the problem. Make sure the answers are the same.

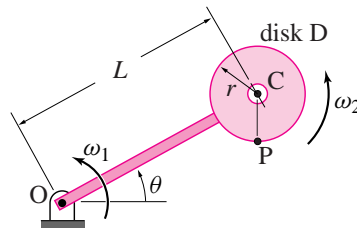

problem 9.12:

(Filename:Mikes93p1)

9.13 A uniform rigid rod AB of length $\ell = 1$ m rotates at a constant angular speed ω about an unknown fixed point. At the instant shown,

the velocities of the two ends of the rod are $\vec{v}_A = -1$ m/s \hat{i} and $\vec{v}_B = 1$ m/s \hat{j} .

- Find the angular velocity of the rod.
- Find the center of rotation of the rod.

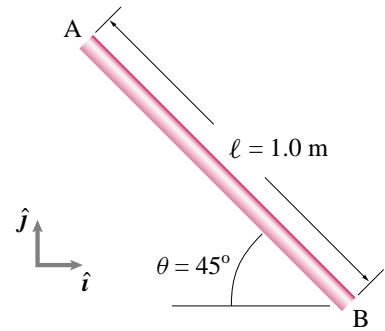

problem 9.13:

(Filename:pfimage4.3.rp6)

9.14 A square plate $ABCD$ rotates at a constant angular speed about an unknown point in its plane. At the instant shown, the velocities of the two corner points A and D are $\vec{v}_A = -2$ ft/s $(\hat{i} + \hat{j})$ and $\vec{v}_D = -(2$ ft/s) \hat{i} , respectively.

- Find the center of rotation of the plate.
- Find the acceleration of the center of mass of the plate.

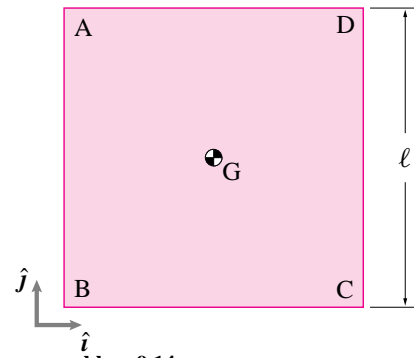

problem 9.14:

(Filename:pfimage4.3.rp7)

9.15 Consider the motion of a rigid ladder which can slide on a wall and on the floor as shown in the figure. The point A on the ladder moves parallel to the wall. The point B moves parallel to the floor. Yet, at a given instant, both have velocities that are consistent with the ladder rotating about some special point, the center of rotation (COR). Define appropriate dimensions for the problem.

- Find the COR for the ladder when it is at some given position (and moving, of course). Hint, if a point A is 'going in circles' about another point C , that other point C must be in the direction perpendicular to the motion of A .
- As the ladder moves, the COR changes with time. What is the set of points on the plane that are the COR's for the ladder as it falls from straight up to lying on the floor?

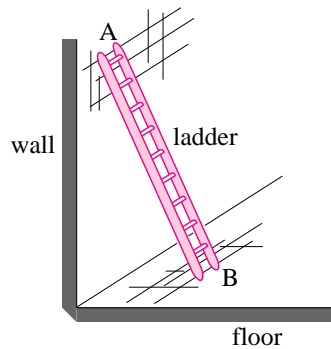

problem 9.15:

(Filename:pfigure.blue.96.1)

9.16 A car driver on a very boring highway is carefully monitoring her speed. Over a one hour period, the car travels on a curve with constant radius of curvature, $\rho = 25$ mi, and its speed increases uniformly from 50 mph to 60 mph. What is the acceleration of the of the car half-way through this one hour period, in path coordinates?

9.17 Find expressions for \hat{e}_t , a_t , a_n , \hat{e}_n , and the radius of curvature ρ , at any position (or time) on the given particle paths for

- problem 5.81, *
- problem 5.83,
- problem 10.5,
- problem 5.85,
- problem 5.84, and
- problem 5.82.

9.18 A particle travels at non-constant speed on an elliptical path given by $y^2 = b^2(1 - \frac{x^2}{a^2})$. Carefully sketch the ellipse for particular values of a and b . For various positions of the particle on the path, sketch the position vector $\vec{r}(t)$; the polar coordinate basis vectors \hat{e}_r and \hat{e}_θ ; and the path coordinate basis vectors \hat{e}_n and \hat{e}_t . At what points on the path are \hat{e}_r and \hat{e}_n parallel (or \hat{e}_θ and \hat{e}_t parallel)?

9.2 Unconstrained Dynamics of 2-D rigid-body planar motion

9.19 A uniform disc of mass m and radius r rotates with angular velocity $\omega \hat{k}$. Its center of mass translates with velocity $\vec{v} = \dot{x} \hat{i} + \dot{y} \hat{j}$ in the xy -plane. What is the total kinetic energy of the disk?

9.20 The uniform rectangle of width $a = 1$ m, length $b = 2$ m, and mass $m = 1$ kg in the figure is sliding on the $x - y$ plane with no friction. At the moment in question, point C is at $x_C = 3$ m and $y_C = 2$ m. The linear momentum is $\vec{L} = 4 \hat{i} + 3 \hat{j}$ (kg·m/s) and the angular momentum about the center of mass

is $\vec{H}_{cm} = 5 \hat{k}$ (kg·m/s²). Find the acceleration of any point on the body that you choose. (Mark it.) [Hint: You have been given some useless information.]

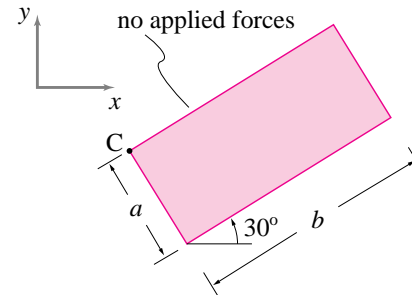

problem 9.20:

(Filename:pfigure.blue.101.1)

9.21 The vertical pole AB of mass m and length ℓ is initially, at rest on a frictionless surface. A tension T is suddenly applied at A. What is \ddot{x}_{cm} ? What is $\dot{\theta}_{AB}$? What is \ddot{x}_B ? Gravity may be ignored.

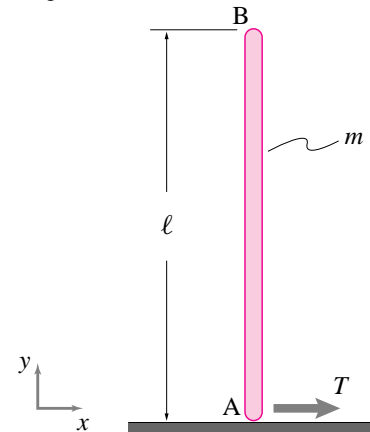

problem 9.21:

(Filename:pfigure.blue.95.1)

9.22 Force on a stick in space. 2-D . No gravity. A uniform thin stick with length ℓ and mass m is, at the instant of interest, parallel to the y axis and has no velocity and no angular velocity. The force $\vec{F} = F \hat{i}$ with $F > 0$ is suddenly applied at point A. The questions below concern the instant after the force \vec{F} is applied.

- What is the acceleration of point C, the center of mass? *
- What is the angular acceleration of the stick? *
- What is the acceleration of the point A? *
- (relatively harder) What additional force would have to be applied to point B to make point B's acceleration zero? *

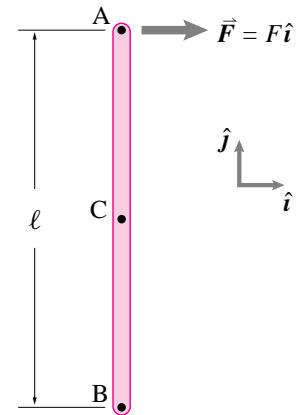

problem 9.22:

(Filename:pfigure.s94h10p2)

9.23 A uniform thin rod of length ℓ and mass m stands vertically, with one end resting on a frictionless surface and the other held by someone's hand. The rod is released from rest, displaced slightly from the vertical. No forces are applied during the release. There is gravity.

- Find the path of the center of mass.
- Find the force of the floor on the end of the rod just before the rod is horizontal.

9.24 A uniform disk, with mass center labeled as point G, is sitting motionless on the frictionless xy plane. A massless peg is attached to a point on its perimeter. This disk has radius of 1 m and mass of 10 kg. A constant force of $F = 1000 \text{ N} \hat{i}$ is applied to the peg for .0001 s (one ten-thousandth of a second).

- What is the velocity of the center of mass of the center of the disk after the force is applied?
- Assuming that the idealizations named in the problem statement are exact is your answer to (a) exact or approximate?
- What is the angular velocity of the disk after the force is applied?
- Assuming that the idealizations named in the problem statement are exact is your answer to (c) exact or approximate?

9.25 A uniform thin flat disc is floating in space. It has radius R and mass m . A force F is applied to it a distance d from the center in the y direction. Treat this problem as two-dimensional.

- What is the acceleration of the center of the disc? *
- What is the angular acceleration of the disc? *

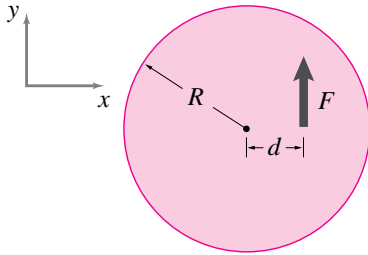

problem 9.25:
(Filename:pfigure.blue.102.1)

9.26 A uniform rectangular metal beam of mass m hangs symmetrically by two strings as shown in the figure.

- Draw a free body diagram of the beam and evaluate $\sum \vec{F}$.
- Repeat (a) immediately after the left string is cut.

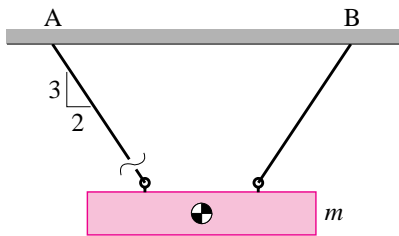

problem 9.26:
(Filename:pfig2.2.rp8)

9.27 A uniform slender bar AB of mass m is suspended from two springs (each of spring constant K) as shown. If spring 2 breaks, determine at that instant

- the angular acceleration of the bar,
- the acceleration of point A, and
- the acceleration of point B.

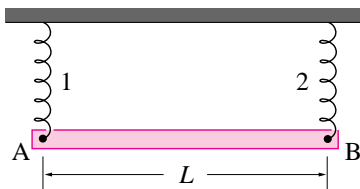

problem 9.27:
(Filename:pfigure.blue.50.2)

9.28 Two small spheres A and B are connected by a rigid rod of length $\ell = 1.0$ ft and negligible mass. The assembly is hung from a hook, as shown. Sphere A is struck, suddenly breaking its contact with the hook and giving it a horizontal velocity $v_0 = 3.0$ ft/s which sends the assembly into free fall. Determine the angular momentum of the assembly about its mass center at point G immediately after A is hit. After the center of mass has fallen two feet, determine:

- the angle θ through which the rod has rotated,
- the velocity of sphere A,
- the total kinetic energy of the assembly of spheres A and B and the rod, and

d) the acceleration of sphere A.

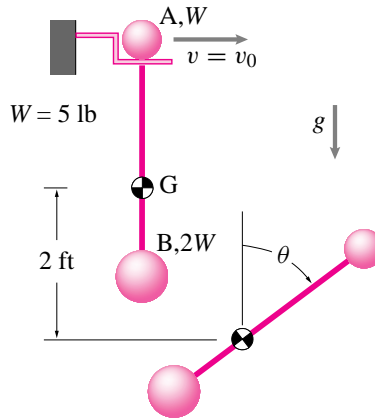

problem 9.28:
(Filename:pfigure.blue.105.1)

The next several problems concern Work, power and energy

9.29 Verify that the expressions for work done by a force F , $W = F\Delta S$, and by a moment M , $W = M\Delta\theta$, are dimensionally correct if ΔS and $\Delta\theta$ are linear and angular displacements respectively.

9.30 Calculate the energy stored in a spring using the expression $E_P = \frac{1}{2}k\delta^2$ if the spring is compressed by 100 mm and the spring constant is 100 N/m.

9.31 A point mass ' m ' is pulled straight up by two strings. The two strings pull the mass symmetrically about the vertical axis with constant and equal force t . At an instant in time t , the position and the velocity of the mass are $y(t)\hat{j}$ and $\dot{y}(t)\hat{j}$, respectively. Draw a free body diagram of the mass at the instant of interest and evaluate the left hand side of the energy balance equation ($P = \dot{E}_K$).

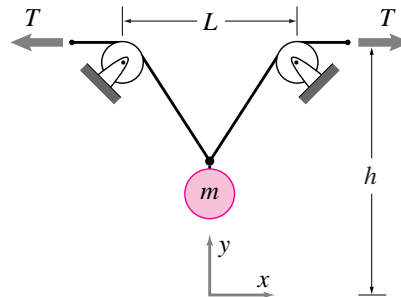

problem 9.31:
(Filename:pfig2.3.rp2)

9.32 In a rack and pinion system, the rack is acted upon by a constant force $F = 50$ N and has speed $v = 2$ m/s in the direction of the force. Find the input power to the system.

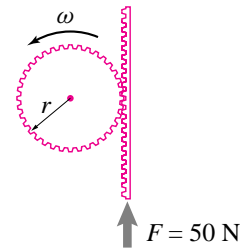

problem 9.32:
(Filename:pfig2.3.rp6)

9.33 The driving gear in a compound gear train rotates at constant speed ω_0 . The driving torque is M_{in} . If the driven gear rotates at a constant speed ω_{out} , find:

- the input power to the system, and
- the output torque of the system assuming there is no power loss in the system; i.e., power in = power out.

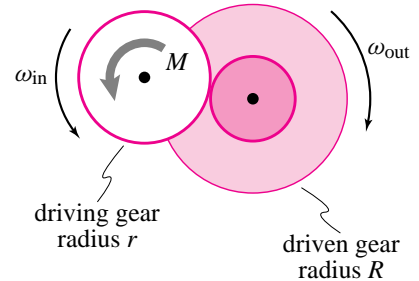

problem 9.33:
(Filename:pfig2.3.rp7)

9.34 An elaborate frictionless gear box has an input and output roller with $V_{in} = const$. Assuming that $V_{out} = 7V_{in}$ and the force between the left belt and roller is $F_{in} = 3$ lb:

- What is F_{out} (draw a picture defining the signs of F_{in} and F_{out})? *
- Is F_{out} greater or less than the F_{in} ? (Assume $F_{in} > 0$.) Why? *

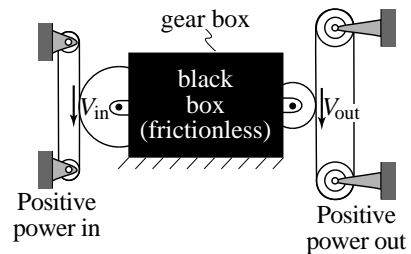

problem 9.34:
(Filename:pfigure.blue.138.1)

9.3 Special topics in planar kinematics

9.4 Mechanics of contacting bodies: rolling and sliding

9.35 A uniform disc of mass m and radius r rolls without slip at constant rate. What is the total kinetic energy of the disk?

9.36 A non-uniform disc of mass m and radius r rolls without slip at constant rate. The center of mass is located at a distance $\frac{r}{2}$ from the center of the disc. What is the total kinetic energy of the disc when the center of mass is directly above the center of the disc?

9.37 Falling hoop. A bicycle rim (no spokes, tube, tire, or hub) is idealized as a hoop with mass m and radius R . G is at the center of the hoop. An inextensible string is wrapped around the hoop and attached to the ceiling. The hoop is released from rest at the position shown at $t = 0$.

- Find y_G at a later time t in terms of any or all of m , R , g , and t .
- Does G move sideways as the hoop falls and unrolls?

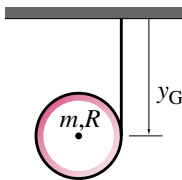

problem 9.37: (Filename:p.s96.p3.2)

9.38 A uniform disk with radius R and mass m has a string wrapped around it. The string is pulled with a force F . The disk rolls without slipping.

- What is the angular acceleration of the disk, $\vec{\alpha}_{Disk} = -\theta\hat{k}$? Make any reasonable assumptions you need that are consistent with the figure information and the laws of mechanics. State your assumptions. *
- Find the acceleration of the point A in the figure. *

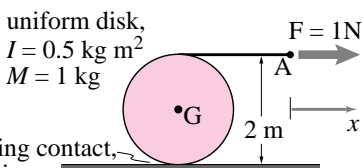

problem 9.38: (Filename:figure.blue.43.1)

9.39 If a pebble is stuck to the edge of the wheel in problem 9.9, what is the maximum speed of the pebble during the motion? When is the force on the pebble from the wheel maximum? Draw a good FBD including the force due to gravity.

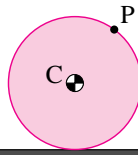

problem 9.39: (Filename:pfigure.s94h11p2.a)

9.40 Spool Rolling without Slip and Pulled by a Cord. See also problem 9.42. The light-weight spool is nearly empty but a lead ball with mass m has been placed at its center. A force F is applied in the horizontal direction to the cord wound around the wheel. Dimensions are as marked. Coordinate directions are as marked.

- What is the acceleration of the center of the spool? *
- What is the horizontal force of the ground on the spool? *

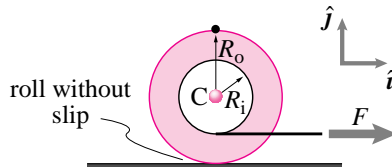

problem 9.40: (Filename:pfigure.s94h11p5)

9.41 A film spool is placed on a very slippery table. Assume that the film and reel (together) have mass distributed the same as a uniform disk of radius R_i . What, in terms of R_i , R_o , m , g , \hat{i} , \hat{j} , and F are the accelerations of points C and B at the instant shown (the start of motion)?

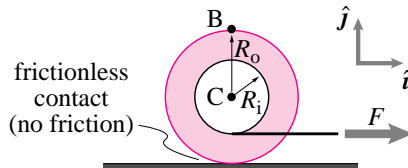

problem 9.41: (Filename:p.f96.f.4)

9.42 Again, Spool Rolling without Slip and Pulled by a Cord. Reconsider the spool from problem 9.40. This time, a force F is applied vertically to the cord wound around the wheel. In this case, what is the acceleration of the center of the spool? Is it possible to pull the cord at some angle between horizontal and vertical so that the angular acceleration of the spool or the acceleration of the center of mass is zero? If so, find the angle in terms of R_i , R_o , m , and F .

9.43 A napkin ring lies on a thick velvet tablecloth. The thin ring (of mass m , radius r) rolls without slip as a mischievous child pulls the tablecloth (mass M) out with acceleration A . The ring starts at the right end ($x = d$). You can make a reasonable physical model of this situation with an empty soda can and a piece of paper on a flat table.

- What is the ring's acceleration as the tablecloth is being withdrawn?
- How far has the tablecloth moved to the right from its starting point $x = 0$ when the ring rolls off its left-hand end?
- Clearly describe the subsequent motion of the ring. Which way does it end up rolling at what speed?
- Would your answer to the previous question be different if the ring slipped on the cloth as the cloth was being pulled out?

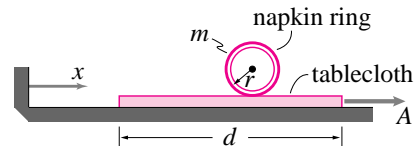

problem 9.43: (Filename:pfigure.blue.51.1)

9.44 A block of mass M is supported by two rollers (uniform cylinders) each of mass m and radius r . They roll without slip on the block and the ground. A force F is applied in the horizontal direction to the right, as shown in the figure. Given F , m , r , and M , find:

- the acceleration of the block,
- the acceleration of the center of mass of this block/roller system,
- the reaction at the wheel bases,
- the force of the right wheel on the block,
- the acceleration of the wheel centers, and
- the angular acceleration of the wheels.

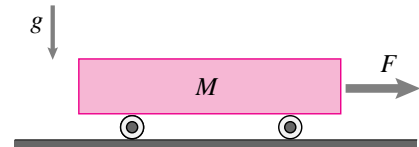

problem 9.44: (Filename:pfigure.blue.108.2)

9.45 Dropped spinning disk. 2-D. A uniform disk of radius R and mass m is gently dropped onto a surface and doesn't bounce. When it is released it is spinning clockwise at the rate θ_0 . The disk skids for a while and then is eventually rolling.

- What is the speed of the center of the disk when the disk is eventually rolling (answer in terms of g , μ , R , θ_0 , and m)? *
- In the transition from slipping to rolling, energy is lost to friction. How does the amount lost depend on the coefficient of friction (and other parameters)? How does this loss make or not make sense in the limit as $\mu \rightarrow 0$ and the dissipation rate \rightarrow zero? *

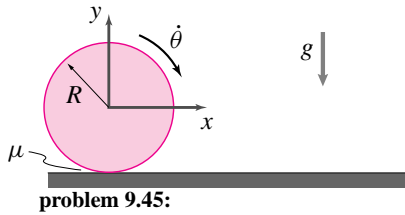

problem 9.45:

(Filename: pfigure.s95q10)

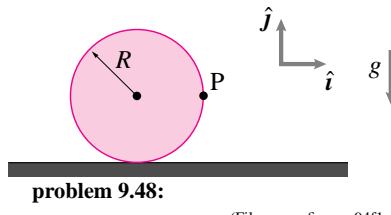

problem 9.48:

(Filename: pfigure.s94f1p1)

9.46 Disk on a conveyor belt. A uniform metal cylinder with mass of 200 kg is carried on a conveyor belt which moves at $V_0 = 3$ m/s. The disk is not rotating when on the belt. The disk is delivered to a flat hard platform where it slides for a while and ends up rolling. How fast is it moving (i.e. what is the speed of the center of mass) when it eventually rolls? *

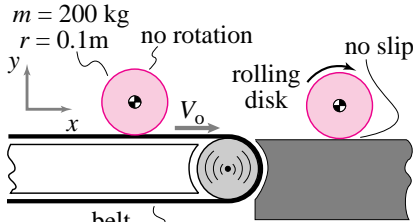

problem 9.46:

(Filename: pfigure.s94h1p3)

9.47 A rigid hoop with radius R and mass m is rolling without slip so that its center has translational speed v_o . It then hits a narrow bar with height $R/2$. When the hoop hits the bar suddenly it sticks and doesn't slide. It does hinge freely about the bar, however. The gravitational constant is g . How big is v_o if the hoop just barely rolls over the bar? *

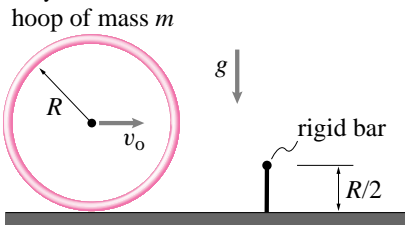

problem 9.47:

(Filename: pfigure.blue.87.5)

9.48 2-D rolling of an unbalanced wheel. A wheel, modeled as massless, has a point mass (mass = m) at its perimeter. The wheel is released from rest at the position shown. The wheel makes contact with coefficient of friction μ .

- What is the acceleration of the point P just after the wheel is released if $\mu = 0$?
- What is the acceleration of the point P just after the wheel is released if $\mu = 2$?
- Assuming the wheel rolls without slip (no-slip requires, by the way, that the friction be high: $\mu = \infty$) what is the velocity of the point P just before it touches the ground?

9.49 Spool and mass. A reel of mass M and moment of inertia $I_{zz}^{cm} = I$ rolls without slipping upwards on an incline with slope-angle α . It is pulled up by a string attached to mass m as shown. Find the acceleration of point G in terms of some or all of M, m, I, R, r, α, g and any base vectors you clearly define.

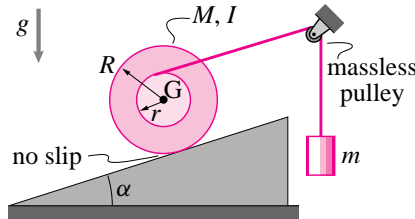

problem 9.49:

(Filename: s97f4)

9.50 Two objects are released on two identical ramps. One is a sliding block (no friction), the other a rolling hoop (no slip). Both have the same mass, m , are in the same gravity field and have the same distance to travel. It takes the sliding mass 1 s to reach the bottom of the ramp. How long does it take the hoop? [Useful formula: " $s = \frac{1}{2}at^2$ "]

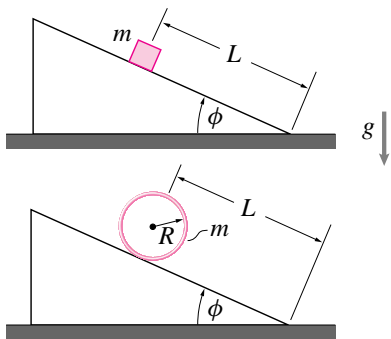

problem 9.50:

(Filename: pfigure.blue.51.2)

9.51 The hoop is rolled down an incline that is 30° from horizontal. It does not slip. It does not fall over sideways. It is let go from rest at $t = 0$.

- At $t = 0^+$ what is the acceleration of the hoop center of mass?
- At $t = 0^+$ what is the acceleration of the point on the hoop that is on the incline?
- At $t = 0^+$ what is the acceleration of the point on the hoop that is furthest from the incline?

d) After the hoop has descended 2 vertical meters (and traveled an appropriate distance down the incline) what is the acceleration of the point on the hoop that is (at that instant) furthest from the incline?

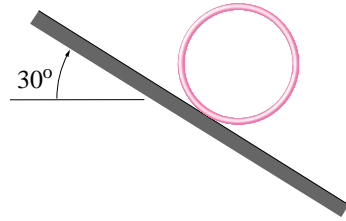

problem 9.51:

(Filename: pfigure.blue.47.1)

9.52 A uniform cylinder of mass m and radius r rolls down an incline without slip, as shown below. Determine: (a) the angular acceleration α of the disk; (b) the minimum value of the coefficient of (static) friction μ that will insure no slip.

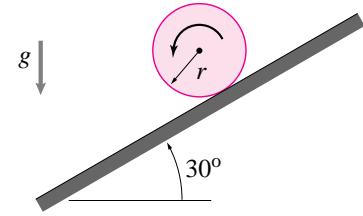

problem 9.52:

(Filename: pfigure.blue.49.3)

9.53 Race of rollers. A uniform disk with mass M_0 and radius R_0 is allowed to roll down the frictionless but quite slip-resistant ($\mu = 1$) 30° ramp shown. It is raced against four other objects (A, B, C and D), one at a time. Who wins the races, or are there ties? First try to construct any plausible reasoning. Good answers will be based, at least in part, on careful use of equations of mechanics. *

- Block A has the same mass and has center of mass a distance R_0 from the ramp. It rolls on massless wheels with frictionless bearings.
- Uniform disk B has the same mass ($M_B = M_0$) but twice the radius ($R_B = 2R_0$).
- Hollow pipe C has the same mass ($M_C = M_0$) and the same radius ($R_C = R_0$).
- Uniform disk D has the same radius ($R_D = R_0$) but twice the mass ($M_D = 2M_0$).

Can you find a round object which will roll as fast as the block slides? How about a massless cylinder with a point mass in its center? Can you find an object which will go slower than the slowest or faster than the fastest of these objects? What would they be and why? (This problem is harder.)

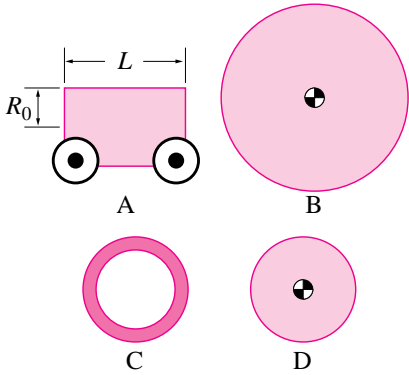
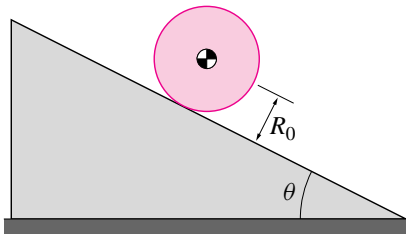

problem 9.53:

(Filename:pfigure.s94h11p4)

9.54 A roller of mass M and polar moment of inertia about the center of mass I_G is connected to a spring of stiffness K by a frictionless hinge as shown in the figure. Consider two kinds of friction between the roller and the surface it moves on:

1. Perfect slipping (no friction), and
 2. Perfect rolling (infinite friction).
- a) What is the period of oscillation in the first case?
 - b) What is the period of oscillation in the second case?

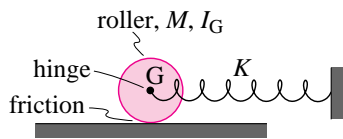

problem 9.54:

(Filename:pfigure.blue.141.2)

9.55 A uniform cylinder of mass m and radius R rolls back and forth without slipping through small amplitudes (i.e., the springs attached at point A on the rim act linearly and the vertical change in the height of point A is negligible). The springs, which act both in compression and tension, are unextended when A is directly over C.

- a) Determine the differential equation of motion for the cylinder's center.
- b) Calculate the natural frequency of the system for small oscillations.

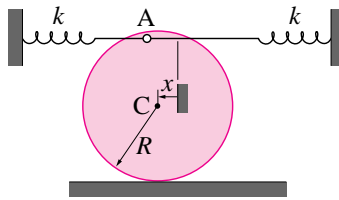

problem 9.55:

(Filename:pfigure.blue.152.1)

9.56 A disk rolls in a cylinder. For all of the problems below, the disk rolls without slip and s back and forth due to gravity.

- a) **Sketch.** Draw a neat sketch of the disk in the cylinder. The sketch should show all variables, coordinates and dimension used in the problem.
- b) **FBD.** Draw a free body diagram of the disk.
- c) **Momentum balance.** Write the equations of linear and angular momentum balance for the disk. Use the point on the cylinder which touches the disk for the angular momentum balance equation. Leave as unknown in these equations variables which you do not know.
- d) **Kinematics.** The disk rolling in the cylinder is a *one-degree-of-freedom* system. That is, the values of only *one* coordinate and its derivatives are enough to determine the positions, velocities and accelerations of all points. The angle that the line from the center of the cylinder to the center of the disk makes from the vertical can be used as such a variable. Find all of the velocities and accelerations needed in the momentum balance equation in terms of this variable and it's derivative. [Hint: you'll need to think about the rolling contact in order to do this part.]
- e) **Equation of motion.** Write the angular momentum balance equation as a single second order differential equation.
- f) **Simple pendulum?** Does this equation reduce to the equation for a pendulum with a point mass and length equal to the radius of the cylinder, when the disk radius gets arbitrarily small? Why, or why not?
- g) **How many?** How many parts can one simple question be divided into?

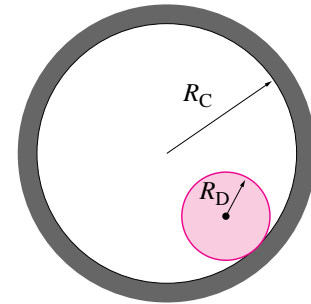

problem 9.56: A disk rolls without slip inside a bigger cylinder.

(Filename:h12.3)

9.57 A uniform hoop of radius R_1 and mass m rolls from rest down a semi-circular track of radius R_2 as shown. Assume that no slipping occurs. At what angle θ does the hoop leave the track and what is its angular velocity ω and the linear velocity \vec{v} of its center of mass at that instant? If the hoop slides down the track without friction, so that it does not rotate, will it leave at a smaller or larger angle θ than if it rolls without slip (as above)? Give a qualitative argument to justify your answer.

HINT: Here is a geometric relationship between angle ϕ hoop turns through and angle θ subtended by its center when no slipping occurs: $\phi = [(R_1 + R_2)/R_2]\theta$. (You may or may not need to use this hint.)

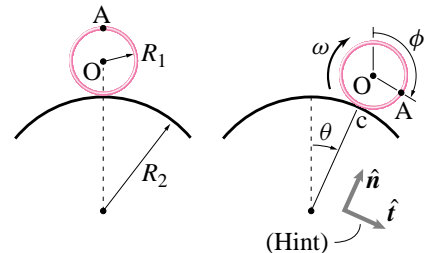

problem 9.57:

(Filename:pfigure.blue.46.1)

9.5 Collisions

9.58 The two blocks shown in the figure are identical except that one rests on two springs while the other one sits on two massless wheels. Draw free body diagrams of each mass as each is struck by a hammer. Here we are interested in the free body diagrams only during collision. Therefore, ignore all forces that are much smaller than the *impulsive* forces. State in words why the forces you choose to show should not be ignored during the collision.

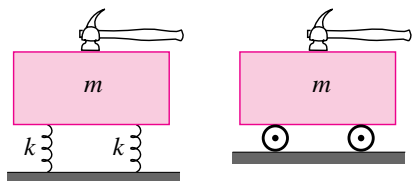

problem 9.58:

(Filename: pfig2.1.rp9)

9.59 These problems concerns two colliding masses. In the first case In (a) the smaller mass hits the hanging mass from above at an angle 45° with the vertical. In (b) second case the smaller mass hits the hanging mass from below at the same angle. Assuming perfectly elastic impact between the balls, find the velocity of the hanging mass just after the collision. [Note, these problems are *not* well posed and can only be solved if you make additional modeling assumptions.]

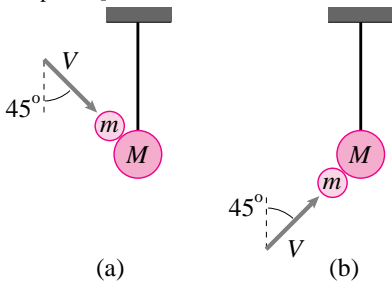

problem 9.59:

(Filename: pfig2.2.rp7)

9.60 A narrow pole is in the middle of a pond with a 10 m rope tied to it. A frictionless ice skater of mass 50 kg and speed 3 m/s grabs the rope. The rope slowly wraps around the pole. What is the speed of the skater when the rope is 5 m long? (A tricky question.)

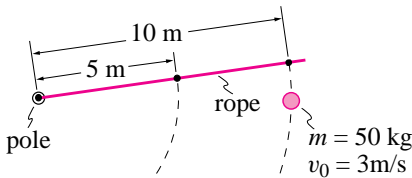

problem 9.60:

(Filename: pfigure.blue.49.1)

9.61 The masses m and $3m$ are joined by a light-weight bar of length 4ℓ . If point A in the center of the bar strikes fixed point B vertically with velocity V_0 , and is not permitted to rebound, find θ of the system immediately after impact.

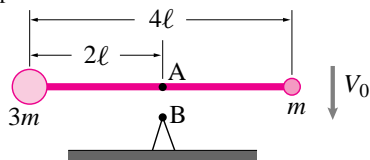

problem 9.61: Neglect gravity!

(Filename: pfigure.blue.81.1)

9.62 Two equal masses each of mass m are joined by a massless rigid rod of length ℓ . The assembly strikes the edge of a table as shown in the figure, when the center of mass is moving downward with a linear velocity v and the system is rotating with angular velocity $\dot{\phi}$ in the counter-clockwise sense. The impact is 'elastic'. Find the immediate subsequent motion of the system, assuming that no energy is lost during the impact and that there is no gravity. Show that there is an interchange of translational and rotational kinetic energy.

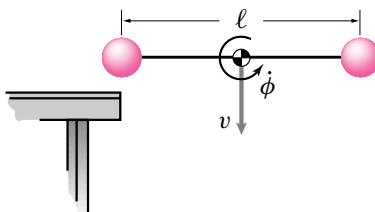

problem 9.62:

(Filename: pfigure.blue.137.2)

9.63 In the *absence of gravity*, a thin rod of mass m and length ℓ is initially tumbling with constant angular speed ω_0 , in the counter-clockwise direction, while its mass center has constant speed v_0 , directed as shown below. The end A then makes a perfectly plastic collision with a rigid peg O (via a hook). The velocity of the mass center happens to be perpendicular to the rod just before impact.

- What is the angular speed ω_f immediately after impact?
- What is the angular speed 10 seconds after impact? Why?
- What is the loss in energy in the plastic collision?

Before impact

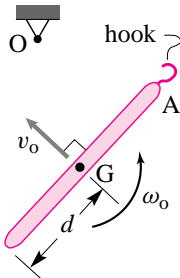

After impact

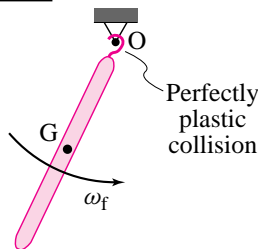

problem 9.63:

(Filename: pfigure.blue.78.2)

9.64 A gymnast of mass m and extended height L is performing on the uneven parallel bars. About the x, y, z axes which pass through her center of mass, her radii of gyration are k_x, k_y , and k_z , respectively. Just before she grasps the top bar, her fully extended body is horizontal and rotating with angular rate ω ; her center of mass is then stationary. Neglect any friction between the bar and her hands and assume that she remains rigid throughout the entire stunt.

- What is the gymnast's rotation rate just *after* she grasps the bar? State clearly any approximations/assumptions that you make.
- Calculate the linear speed with which her hips (CM) strike the lower bar. State all assumptions/approximations.
- Describe (in words, no equations please) her motion immediately after her hips strike the lower bar if she releases her hands just prior to this impact.

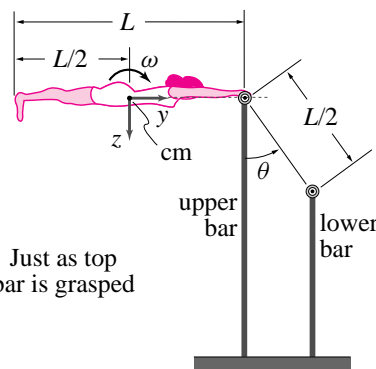

Just as top bar is grasped

problem 9.64:

(Filename: pfigure.blue.130.2)

9.65 An acrobat modelled as a rigid body.

An acrobat is modeled as a uniform rigid mass m of length l . The acrobat falls without rotation in the position shown from height h where she was stationary. She then grabs a bar with a firm but slippery grip. What is h so that after the subsequent motion the acrobat ends up in a stationary handstand? [Hints: Note what quantities are preserved in what parts of the motion.] *

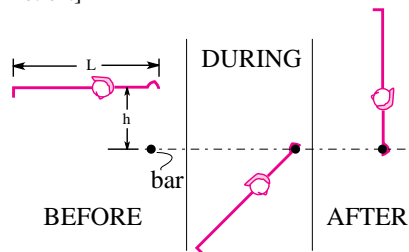

problem 9.65:

(Filename: pfigure.s94h10p4)

9.66 A crude see-saw is built with two supports separated by distance d about which a rigid plank (mass m , length L) can pivot smoothly. The plank is placed symmetrically, so that its

center of mass is midway between the supports when the plank is at rest.

- While the left end is resting on the left support, the right end of the plank is lifted to an angle θ and released. At what angular velocity ω_1 will the plank strike the right hand support?
- Following the impact, the left end of the plank can pivot purely about the right end if d/L is properly chosen and the right end does not bounce. Find ω_2 under these circumstances.

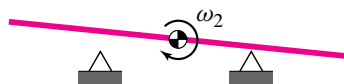
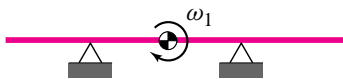
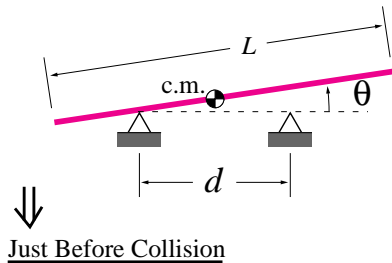

problem 9.66:

(Filename:figure.blue.81.2)

9.67 Baseball bat. In order to convey the ideas without making the calculation too complicated, some of the simplifying assumptions here are highly approximate. Assume that a bat is a uniform rigid stick with length L and mass m_s . The motion of the bat is pivoting about one end held firmly in place with hands that rotate but do not move. The swinging of the bat occurs by the application of a constant torque M_s at the hands over an angle of $\theta = \pi/2$ until the point of impact with the ball. The ball has mass m_b and arrives perpendicular to the bat at an absolute speed v_b at a point a distance ℓ from the hands. The collision between the bat and the ball is completely elastic.

- To maximize the speed v_{hit} of the hit ball *How heavy should a baseball bat be? Where should the ball hit the bat?* Here are some hints for one way to approach the problem.
 - Find the angular velocity of the bat just before collision by drawing a FBD of the bat etc.
 - Find the total energy of the ball and bat system just before the collision.
 - Draw a FBD of the ball and of the bat during the collision (with this model there is an impulse at

the hands on the bat). Call the magnitude of the impulse of the ball on the bat (and visa versa) $\int F dt$.

- Use various momentum equations to find the angular velocity of the bat and velocity of the ball just after the collision in terms of $\int F dt$ and other quantities above. Use these to find the energy of the system just after collision.
- Solve for the value of $\int F dt$ that conserves energy. As a check you should see if this also predicts that the relative separation speed of the ball and bat (at the impact point) is the same as the relative approach speed (it should be).
- You now know can calculate v_{hit} in terms of $m_b, m_s, M_s, L, \ell,$ and v_b .
- Find the maximum of the above expression by varying m_s and ℓ . Pick numbers for the fixed quantities if you like.

- Can you explain in words what is wrong with a bat that is too light or too heavy?
- Which aspects of the model above do you think lead to the biggest errors in predicting what a real ball player should pick for a bat and place on the bat to hit the ball?
- Describe as clearly as possible a different model of a baseball swing that you think would give a more accurate prediction. (You need not do the calculation).

Problems for Chapter 10

Kinematics using time-varying base vectors Problems for all three sections of this chapter are combined.

10.1 Polar coordinates and path coordinates

10.2 Rotating reference frames

10.3 General expressions for velocity and acceleration

10.1 Express the basis vectors (\hat{i}', \hat{j}') associated with axes x' and y' in terms of the standard basis (\hat{i}, \hat{j}) for $\theta = 30^\circ$.

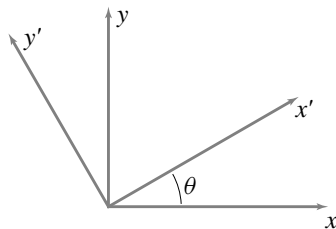

problem 10.1:

(Filename:efig1.2.23)

10.2 Body frames are frames of reference attached to a body in motion. The orientation of a coordinate system attached to a body frame \mathcal{B} is shown in the figure at some moment of interest. For $\theta = 60^\circ$, express the basis vectors (\hat{b}_1, \hat{b}_2) in terms of the standard basis (\hat{i}, \hat{j}) .

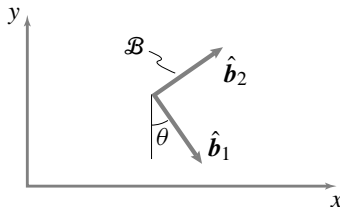

problem 10.2:

(Filename:efig1.2.24)

10.3 Find the components of (a) $\vec{v} = 3 \text{ m/s}\hat{i} + 2 \text{ m/s}\hat{j} + 4 \text{ m/s}\hat{k}$ in the rotated basis $(\hat{i}', \hat{j}', \hat{k}')$ and (b) $\vec{a} = -0.5 \text{ m/s}^2\hat{j}' + 3.0 \text{ m/s}^2\hat{k}'$ in the standard basis $(\hat{i}, \hat{j}, \hat{k})$. (y and y' are in the same direction and x' and z' are in the xz plane.)

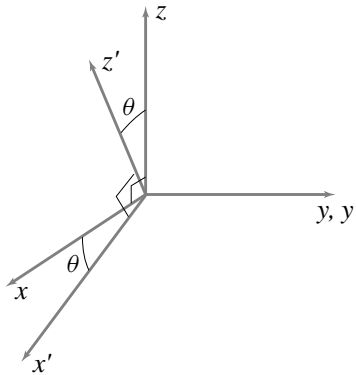

problem 10.3:

(Filename:efig1.2.25)

10.4 For \mathbf{Q} given in problem 12.22 and $\vec{M} = 25 \text{ N}\cdot\text{m}\hat{E}_1 - 32 \text{ N}\cdot\text{m}\hat{E}_2$, find the \hat{e}_2 component of \vec{M} without calculating $[\mathbf{Q}]\{\vec{M}\}$.

10.5 A particle travels in a straight line in the xy -plane parallel to the x -axis at a distance $y = \ell$ in the positive x direction. The position of the particle is denoted by $\vec{r}(t)$. The angle of \vec{r} measured positive counter-clockwise from the x axis is decreasing at a constant rate with magnitude ω . If the particle starts on the y axis at $\theta = \pi/2$, what is $\vec{r}(t)$ in cartesian coordinates?

10.6 Given that $\vec{r}(t) = ct^2\hat{i}'$ and that $\theta(t) = d \sin(\lambda t)$ find $\vec{v}(t)$

- (a) in terms of \hat{i} and \hat{j} ,
- (b) in terms of \hat{i}' and \hat{j}' .

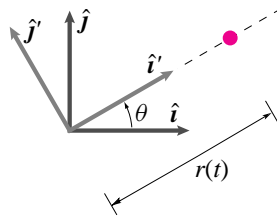

problem 10.6:

(Filename:pfig3.1.DH1)

10.7 A bug walks on a straight line engraved on a rotating turntable (the bug's path in the room is not a straight line). The line passes through the center of the turntable. The bug's speed on this line is 1 in/s (the bug's absolute speed is *not* 1 in/s). The turntable rotates at a constant rate of 2 revolutions every π s in a positive sense about the z -axis. It's surface is always in the

xy -plane. At time $t = 0$, the engraved line is aligned with the x -axis, the bug is at the origin and headed towards the positive x direction.

- a) What is the x component of the bug's velocity at $t = \pi$ s?
- b) What is the y component of the bug's velocity at $t = \pi$ seconds?
- c) What is the y component of the bug's acceleration at $t = \pi$?
- d) What is the radius of curvature of the bug's path at $t = 0$?

10.8 A bug walks on a turntable. In polar coordinates, the position of the bug is given by $\vec{R} = R\hat{e}_r$, where the origin of this coordinate system is at the center of the turntable. The $(\hat{e}_r, \hat{e}_\theta)$ coordinate system is attached to the turntable and, hence, rotates with the turntable. The kinematical quantities describing the bug's motion are $\dot{R} = -\dot{R}_0$, $\ddot{R} = 0$, $\dot{\theta} = \omega_0$, and $\ddot{\theta} = 0$. A fixed coordinate system Oxy has origin O at the center of the turntable. As the bug walks through the center of the turntable:

- a) What is its speed?
- b) What is its acceleration?
- c) What is the radius of the osculating circle (i.e., what is the radius of curvature of the bug's path?)

10.9 Actual path of bug trying to walk a straight line. A straight line is inscribed on a horizontal turntable. The line goes through the center. Let ϕ be angle of rotation of the turntable which spins at constant rate $\dot{\phi}_0$. A bug starts on the outside edge of the turntable of radius R and walks towards the center, passes through it, and continues to the opposite edge of the turntable. The bug walks at a constant speed v_A , as measured by how far her feet move per step, on the line inscribed on the table. Ignore gravity.

- a) **Picture.** Make an accurate drawing of the bug's path as seen in the room (which is not rotating with the turntable). In order to make this plot, you will need to assume values of v_A and $\dot{\phi}_0$ and initial values of R and ϕ . You will need to write a parametric equation for the path in terms of variables that you can plot (probably x and y coordinates). You will also need to pick a range of times. Your plot should include the instant at which the bug walks through the origin. Make sure your x - and y -axes are drawn to the same scale. A computer plot would be nice.
- b) Calculate the radius of curvature of the bug's path as it goes through the origin.

- c) Accurately draw (say, on the computer) the osculating circle when the bug is at the origin on the picture you drew for (a) above.
- d) **Force.** What is the force on the bugs feet from the turntable when she starts her trip? Draw this force as an arrow on your picture of the bug's path.
- e) **Force.** What is the force on the bugs feet when she is in the middle of the turntable? Draw this force as an arrow on your picture of the bug's path.

10.10 A small bug is crawling on a straight line scratched on an old record. The scratch, at its closest, is a distance $\ell = 6$ cm from the center of the turntable. The turntable is turning clockwise at a constant angular rate $\omega = 2$ rad/s. The bug is walking, relative to the turntable, at a constant rate $v_{B/T} = 12$ cm/s, straight along the scratch in the y -direction. At the instant of interest, everything is aligned as shown in figure. The bug has a mass $m_B = 1$ gram.

- a) What is the bug's velocity?
- b) What is the bug's acceleration?
- c) What is the sum of all forces acting on the bug?
- d) Sketch the path of the bug in the neighborhood of its location at the time of interest (indicate the direction the bug is moving on this path).

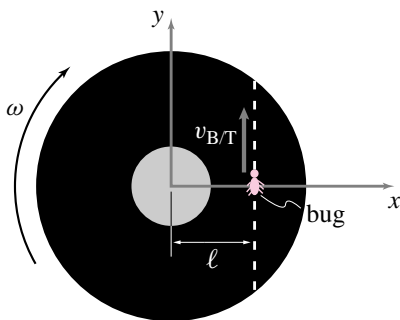

problem 10.10:

(Filename:pfigure.blue.55.2)

10.11 A bug of mass $m = 1$ kg walks on a straight line marked through the center of a turntable on the back of a pick-up truck, exactly as in problem 10.17. Evaluate the absolute velocity and acceleration of the bug in the following situations (in cartesian coordinates):

*

10.12 A turntable oscillates with displacement $\vec{x}_C(t) = A \sin(st)\hat{i}$. The disc of the turntable rotates with angular speed and acceleration ω_D and $\dot{\omega}_D$. A small bug walks along line DE with velocity v_b relative to the turntable. At the instant shown, the turntable is at its maximum amplitude $x = A$, the line DE is currently aligned with the z -axis, and the bug is passing through point B on line DE . Point B is a distance a from the center of the turntable, point C . Find the absolute acceleration of the bug, \vec{a}_b . *

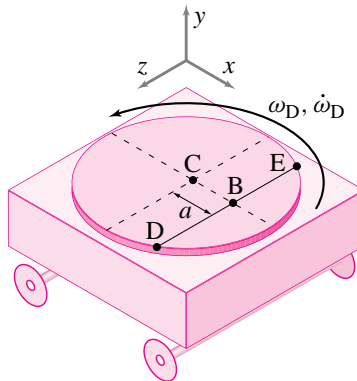

problem 10.12:

(Filename:Mikes93p2)

- e) What is the total force acting on the train?
- f) Sketch the path of the train for one revolution of the turntable (surprise)?

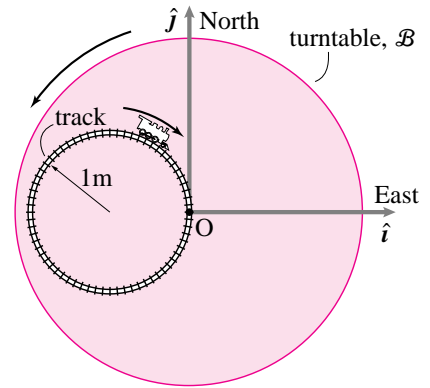

problem 10.13:

(Filename:pfigure.f93f4)

10.13 See also problem 10.15. A small .1 kg toy train engine is going clockwise at a constant rate (relative to the track) of 2 m/s on a circular track of radius 1 m. The track itself is on a turntable \mathcal{B} that is rotating counter-clockwise at a constant rate of 1 rad/s. The dimensions are as shown. At the instant of interest the train is pointing due south ($-\hat{j}$) and is at the center

Kinematical Quantities of the turntable.						
	x_T	\dot{x}_T	\ddot{x}_T	r_b	\dot{r}_b	\ddot{r}_b
(a)	4 m	3 m/s	0 m/s ²	1 m	0 m/s	0 m/s ²
(b)	"	"	2 m/s ²	"	"	"
(c)	"	"	0 m/s ²	"	"	"
(d)	"	"	"	"	"	1 m/s ²
(e)	"	"	"	0 m	1 m/s	0 m/s ²
(f)	"	"	"	1 m	0 m/s	"
(g)	"	"	2 m/s ²	"	5 m/s	-2 m/s ²
(h)	"	"	"	"	0 m/s	0 m/s ²
(i)	"	"	4 m/s ²	"	"	"

10.14 A giant bug walks on a horizontal disk. An $x - y - z$ frame is attached to the disk. The disk is rotating about the z axis (out of the paper) and simultaneously translating with respect to an inertial frame $X - Y - Z$ plane. In each of the cases shown in the figure, determine the total force acting on the bug. In each case, the dotted line is scratched on the disk and is the path the bug follows walking in the direction of the arrow. The location of the bug is marked with a dot. At the instants shown, the $x - y - z$ coordinate system shown is aligned with the inertial $X - Y - Z$ frame (which is not shown in the pictures). In this problem:

\vec{r} = the position of the center of the disk,
 \vec{v} = the velocity of the center of the disk,
 \vec{a} = the acceleration of the center of the disk,
 $\vec{\Omega}$ = the angular velocity of the disk (i.e., $\vec{\Omega} = \Omega \hat{k}$),
 $\dot{\Omega}$ = the angular acceleration of the disk,
 u = the speed of the bug traversing the dotted line (arc length on the disk per unit time),
 $\dot{u} = du/dt$, and
 $m = 1$ kg = mass of the bug.

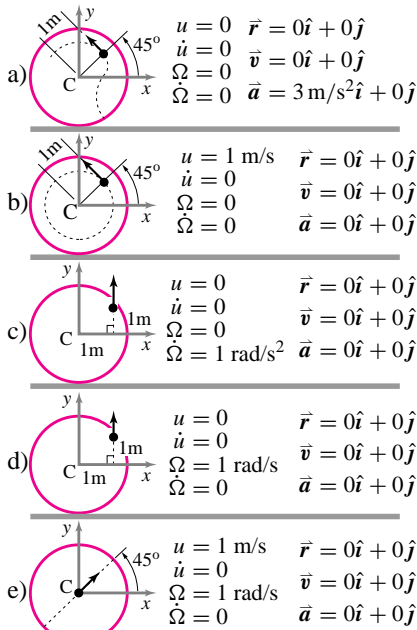

problem 10.14:

(Filename: pfigure.blue.117.1)

10.15 Repeat questions (a)-(f) for the toy train in problem 10.13 going counter-clockwise at constant rate (relative to the track) of 2 m/s on the circular track.

10.16 A honeybee, sensing that it can get a cheap thrill, alights on a phonograph turntable that is being carried by a carnival goer who is riding on a carousel. The situation is sketched below. The carousel has angular velocity of 5 rpm, which is increasing (accelerating) at 10 rev/min²; the phonograph rotates at a constant 33 1/3 rpm. The honeybee is at the outer edge of the phonograph record in the position shown in the figure; the radius of the record is 7 inches. Calculate the magnitude of the acceleration of the honeybee.

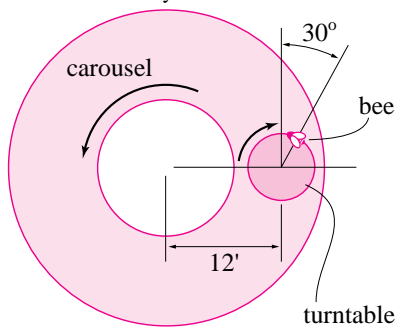

problem 10.16:

(Filename: pfigure.blue.67.2)

10.17 See also problem 10.11. Consider a turntable on the back of a pick-up truck. A bug walks on a line on the turntable. The line may or may not be drawn through the center of the turntable. The truck may or may not be going at constant rate. The turntable may or may not be spinning, and, if it spins, it may or may not go at a constant rate. The bug may be anywhere

on the line and may or may not be walking at a constant rate.

- Draw a picture of the situation.** Clearly define all variables you are going to use. What is the moving frame, and what is the reference point on that frame?
- One term at a time.** For each term in the five term acceleration formula, find a situation where all but one term is zero. Use the turntable as the moving frame, the bug as the particle of interest. *
- Two terms at a time.** (harder) How many situations can you find where a pair of terms is not zero but all other terms are zero? (Don't try to do all 10 cases unless you really think this infamous formula is fun. Try at least one or two.) *

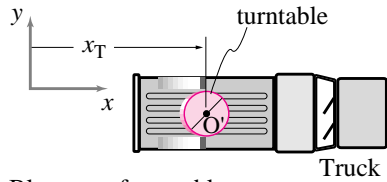

Blow-up of turntable:

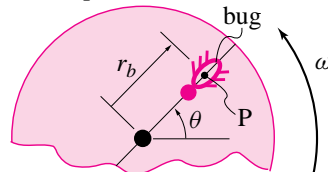

problem 10.17: Picking apart the five term acceleration formula.

(Filename: pfigure.blue.75.1)

10.18 Slider crank kinematics (No FBD required!). 2-D. Assume $R, \ell, \theta, \dot{\theta}, \ddot{\theta}$ are given. The crank mechanism parts move on the xy plane with the x direction being along the piston. Vectors should be expressed in terms of \hat{i}, \hat{j} , and \hat{k} components.

- What is the angular velocity of the crank OA? *
- What is the angular acceleration of the crank OA? *
- What is the velocity of point A? *
- What is the acceleration of point A? *
- What is the angular velocity of the connecting rod AB? [Geometry fact: $\vec{r}_{AB} = \sqrt{\ell^2 - R^2 \sin^2 \theta} \hat{i} - R \sin \theta \hat{j}$]
- For what values of θ is the angular velocity of the connecting rod AB equal to zero (assume $\dot{\theta} \neq 0$)? (you need not answer part (e) correctly to answer this question correctly.) *

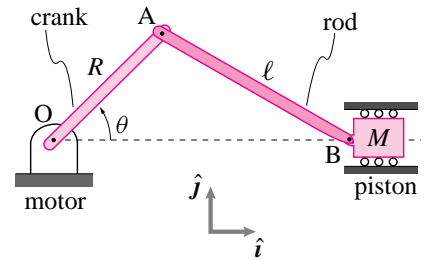

problem 10.18:

(Filename: pfigure.s95q12)

10.19 Slider-Crank. See also problem 11.34. Consider a slider-crank mechanism. Given $\theta, \dot{\theta}, \ddot{\theta}, L$, and R , can you find the velocity and acceleration of B? There are many ways to do this problem.

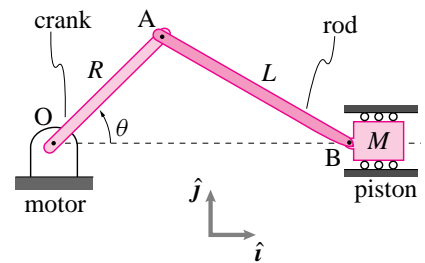

problem 10.19:

(Filename: f.5)

10.20 The crank AB with length $L_{AB} = 1$ inch in the crank mechanism shown rotates at a constant rate $\dot{\theta}_{AB} = \omega_{AB} = 2\pi$ rad/s counter-clockwise. The initial angle of rotation is $\theta = 0$ at $t = 0$. The connecting rod BC has a length of $L_{BC} = 2$ in.

- What is the velocity of point B at the end of the crank when $\theta = \pi/2$ rad?
- What is the velocity of point C at the end of the connecting rod when $\theta = \pi/2$ rad?
- What is the angular velocity of the connecting rod BC when $\theta = \pi/2$ rad?
- What is the angular velocity of the connecting rod BC as a function of time?

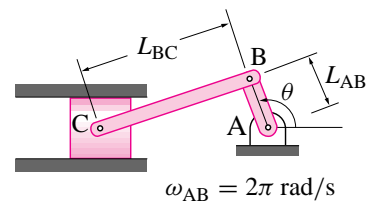

problem 10.20:

(Filename: pfigure.blue.116.1)

10.21 See also problem 10.22. The two rods AB and DE, connected together through a collar C, rotate in the vertical plane. The collar C is pinned to the rod AB but is free to slide on the frictionless rod DE. At the instant shown, rod AB is rotating clockwise with angular speed $\omega = 3$ rad/s and angular acceleration $\alpha = 2$ rad/s². Find the angular velocity of rod DE. *

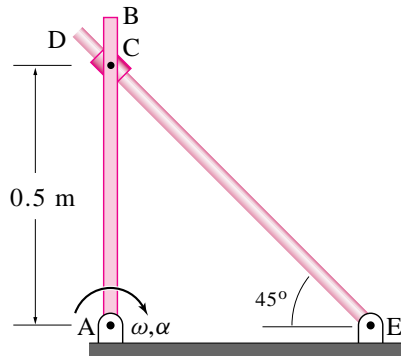

problem 10.21:

(Filename:summer95f.4)

10.22 Reconsider problem 10.21. The two rods AB and DE, connected together through a collar C, rotate in the vertical plane. The collar C is pinned to the rod AB but is free to slide on the frictionless rod DE. At the instant shown, rod AB is rotating clockwise with angular speed $\omega = 3 \text{ rad/s}$ and angular acceleration $\alpha = 2 \text{ rad/s}^2$. Find the angular acceleration of rod DE. *

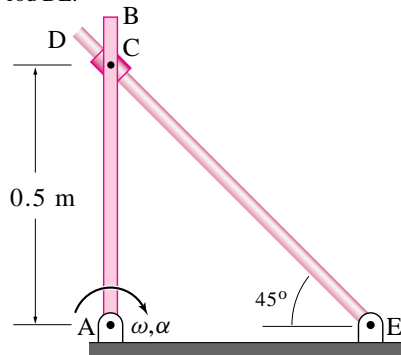

problem 10.22:

(Filename:summer95f.4.a)

10.23 Collar A is constrained to slide on a horizontal rod to the right at constant speed v_A . It is connected by a pin joint to one end of a rigid bar AB with length ℓ which makes an angle θ with the horizontal at the instant of interest. A second collar B connected by a pin joint to the other end of the rigid bar AB slides on a vertical rod.

- Find the velocity of point B. Answer in terms of v_A , θ , ℓ , \hat{i} and \hat{j} .
- Find the angular speed $\dot{\theta}$ of the rod? Answer in terms of v_A , θ , ℓ , \hat{i} and \hat{j} .

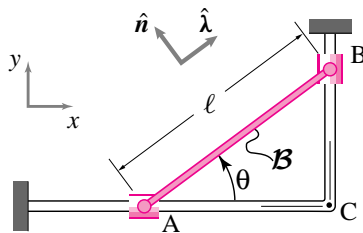

problem 10.23:

(Filename:s93q5)

10.24 A bar of length $\ell = 5 \text{ ft}$, body \mathcal{D} , connects sliders A and B on an L-shaped frame, body \mathcal{L} , which itself is rotating at constant speed about an axle perpendicular to the plane of the figure through the point O and relative to a fixed frame \mathcal{F} , $\dot{\omega}_{\mathcal{L}/\mathcal{F}} = 0.5 \text{ rad/s}$. At the instant shown, body \mathcal{L} is aligned with the $x-y$ axes, slider A is $x_A = 4 \text{ ft}$ from point O, slider B is $y_B = 3 \text{ ft}$ from O. The speed and acceleration of slider B relative to the frame \mathcal{L} are $\vec{v}_{B/\mathcal{L}} = -2 \text{ ft/s} \hat{j}$ and $\vec{a}_{B/\mathcal{L}} = -2 \text{ ft/s}^2 \hat{j}$, respectively.

Determine:

- The absolute velocity of the slider A, $\vec{v}_{A/\mathcal{F}}$, and
- The absolute angular velocity of bar AB, body \mathcal{D} , $\dot{\omega}_{\mathcal{D}/\mathcal{F}}$.

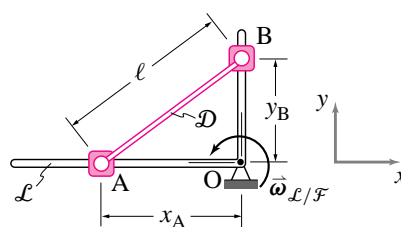

problem 10.24:

(Filename:pfigure.blue.115.1)

10.25 See also problem 11.35. The link AB is supported by a wheel at D and its end A is constrained so that it only has horizontal velocity. No slipping occurs between the wheel and the link. The wheel has an angular velocity ω and radius r . The distance $OA = \ell$.

Given: ω , r , and ℓ . ($\beta = \sin^{-1} \frac{r}{\ell}$). Determine the angular velocity of the link AB and velocity of the point A.

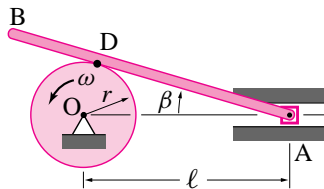

problem 10.25:

(Filename:pfigure.blue.121.1)

10.26 See also problem 11.36. A solid cylinder of radius R and mass M rolls without slip along the ground. A thin rod of mass m and length L is attached by a frictionless pin P to the cylinder's rim and its right end is dragged at a constant speed \vec{v}_A along the (frictionless) horizontal ground.

- For the position shown (where P is directly above the contact point), find P's velocity \vec{v}_P and the rod's angular velocity ω .
- Find P's acceleration \vec{a}_P and the angular acceleration $\dot{\omega}$ of the rod.

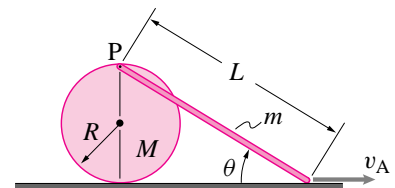

problem 10.26:

(Filename:pfigure.blue.116.2)

10.27 The slotted link CB is driven in an oscillatory motion by the link ED which rotates about D with constant angular velocity $\dot{\theta} = \omega_D$. The pin P is attached to ED at fixed radius d and engages the slot on CB as shown. Find the angular velocity and acceleration $\dot{\theta}$ and $\ddot{\theta}$ of CB when $\theta = \pi/2$.

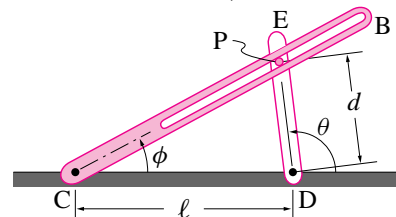

problem 10.27:

(Filename:pfigure.blue.65.3)

10.28 The rod of radius $r = 50 \text{ mm}$ shown has a constant angular velocity of $\omega = 30 \text{ rad/s}$ counterclockwise. Knowing that rod AD is 250 mm long and distance $d = 150 \text{ mm}$, determine the acceleration of collar D when $\theta = 90^\circ$.

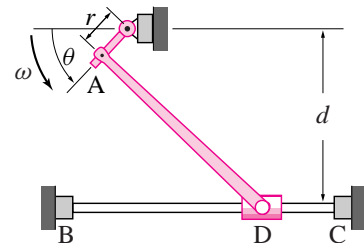

problem 10.28:

(Filename:pfigure.blue.120.1)

10.29 Picking apart the polar coordinate formula for velocity. See also problems 10.30 and 11.52. This problem concerns a small mass m that sits in a slot in a turntable. Alternatively you can think of a small bead that slides on a rod. The mass always stays in the slot (or on the rod). Assume the mass is a little bug that can walk as it pleases on the rod (or in the slot) and you control how the turntable/rod rotates. Name two situations in which one of the terms is zero but the other is not in the two term polar coordinate formula for velocity, $R\hat{e}_R + R\dot{\theta}\hat{e}_\theta$. You should thus gain some insight into the meaning of each of the two terms in that formula. *

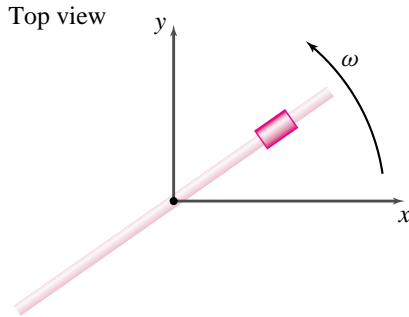
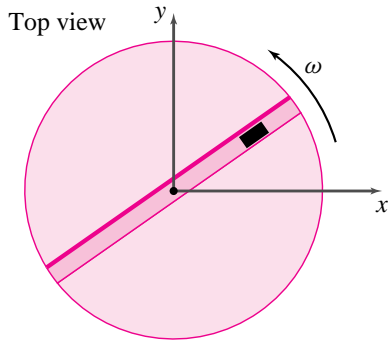

problem 10.29:

(Filename:pfigure.s94h9p4b)

10.30 Picking apart the polar coordinate formula for acceleration. Reconsider the configurations in problem 10.29. This time, name four situations in which all of the terms, but one, in the four term polar coordinate formula for acceleration, $\vec{a} = (\ddot{R} - R\dot{\theta}^2)\hat{e}_R + (2\dot{R}\dot{\theta} + R\ddot{\theta})\hat{e}_\theta$, are zero. Each situation should pick out a different term. You should thus gain some insight into the meaning of each of the four terms in that formula. *

10.31 For the configuration in problem 9.12 what is the absolute angular velocity of the disk, D ? *

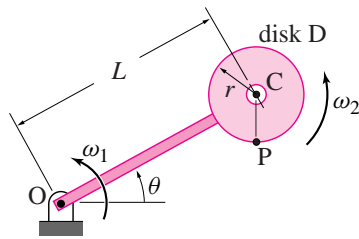

problem 10.31:

(Filename:doublersot1)

10.32 A car driver on a very boring highway is carefully monitoring her speed. Over a one hour period, the car travels on a curve with constant radius of curvature, $\rho = 25$ mi, and its speed increases uniformly from 50 mph to 60 mph. What is the acceleration of the car half-way through this one hour period, in path coordinates?

10.33 Find expressions for \hat{e}_t , a_t , a_n , \hat{e}_n , and the radius of curvature ρ , at any position (or time) on the given particle paths for

- a) problem 5.81, *

- b) problem 5.83,
- c) problem 10.5,
- d) problem 5.85,
- e) problem 5.84, and
- f) problem 5.82.

10.34 A particle travels at non-constant speed on an elliptical path given by $y^2 = b^2(1 - \frac{x^2}{a^2})$. Carefully sketch the ellipse for particular values of a and b . For various positions of the particle on the path, sketch the position vector $\vec{r}(t)$; the polar coordinate basis vectors \hat{e}_r and \hat{e}_θ ; and the path coordinate basis vectors \hat{e}_n and \hat{e}_t . At what points on the path are \hat{e}_r and \hat{e}_n parallel (or \hat{e}_θ and \hat{e}_t parallel)?

10.35 For the configuration in problem 9.12, taking ω_2 to be the angular velocity of disk D relative to the rod, what is the absolute angular acceleration of the disk, D ? What is the absolute angular acceleration of the disk if ω_1 and ω_2 are not constant?

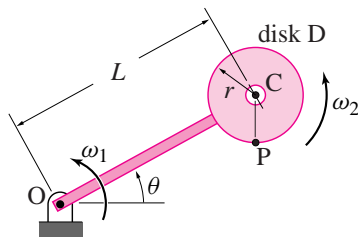

problem 10.35:

(Filename:doublersot.ang.accel)

10.36 Double pendulum. See also problem 10.37. The double pendulum shown is made up of two uniform bars, each of length ℓ and mass m . At the instant shown, ϕ_1 , $\dot{\phi}_1$, ϕ_2 , and $\dot{\phi}_2$ are known. For the instant shown, answer the following questions in terms of ℓ , ϕ_1 , $\dot{\phi}_1$, ϕ_2 , and $\dot{\phi}_2$.

- a) What is the absolute velocity of point A ?
- b) What is the velocity of point B relative to point A ?
- c) What is the absolute velocity of point B ?

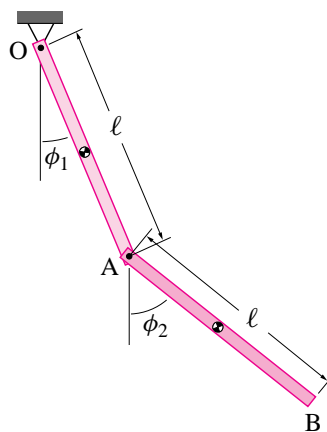

problem 10.36:

(Filename:ch7.8)

10.37 Double pendulum, Again. For the double pendulum in problem 10.36, $\ddot{\phi}_1$ and $\ddot{\phi}_2$ are also known at the instant shown. For the instant shown, answer the following questions in terms of ℓ , ϕ_1 , $\dot{\phi}_1$, $\ddot{\phi}_1$, ϕ_2 , $\dot{\phi}_2$, and $\ddot{\phi}_2$.

- a) What is the absolute acceleration of point A ?
- b) What is the acceleration of point B relative to point A ?
- c) What is the absolute acceleration of point B ?

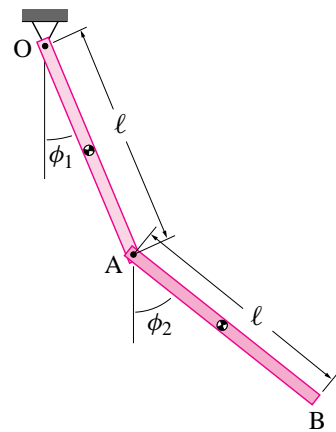

problem 10.37:

(Filename:ch7.8.a)

Problems for Chapter 11

Mechanics of planar mechanisms

11.1 Dynamics of particles in the context of 2D mechanisms

11.1 Several of the problems below concern a narrow rigid hoop and/or a small bead. For reference here are dimensions and values you should use in working the problems: mass of bead $m_{\text{bead}} = 2$ grams, mass of hoop $m_{\text{hoop}} = 1$ kg, radius of hoop $R_{\text{hoop}} = 3$ m, gravitational acceleration $g = 10 \text{ m/s}^2$ (or zero). A bead slides on a frictionless circular hoop. The center of the circular hoop is the origin O of a fixed (Newtonian) coordinate system $Oxyz$. The hoop is on the xy plane. Gravity is in the negative z direction. The hoop is kept from moving by little angels who arrange to let the bead slide by unimpeded. At $t = 0$, the speed of the bead is 4 m/s , it is traveling counterclockwise (looking down the z -axis), and it is on the x -axis. There are no external forces applied.

- At $t = 0$ what is the bead's kinetic energy?
- At $t = 0$ what is the bead's linear momentum?
- At $t = 0$ what is the bead's angular momentum about the origin?
- At $t = 0$ what is the bead's acceleration?
- At $t = 0$ what is the radius of the osculating circle of the bead's path ρ ?
- At $t = 0$ what is the force of the hoop on the bead?
- At $t = 0$ what is the net force of the angel's hands on the hoop?
- At $t = 27s$ what is the x -component of the bead's linear momentum?

Just when the bead above has traveled around the wire exactly 12 times the angels suddenly (but gently) let go of the hoop which is now free to slide on the frictionless xy plane. Call this time $t = 0$. At $t = 0^+$ we can assume the angels have fully let go.

- At $t = 0^+$ what is the linear momentum of the bead and hoop system?
- At $t = 0^+$ what is the rate of change of the linear momentum of the bead and hoop system?

- At $t = 0^+$ What is the value of the acceleration of the bead? (Hint: $\mathbf{a}_{\text{bead}} = \mathbf{a}_{\text{hoop center}} + \mathbf{a}_{\text{bead/hoop center}}$)

11.2 A warehouse operator wants to move a crate of weight $W = 100 \text{ lb}$ from a 6 ft high platform to ground level by means of a roller conveyer as shown. The rollers on the inclined plane are well lubricated and thus assumed frictionless; the rollers on the horizontal conveyer are frictional, thus providing an effective friction coefficient μ . Assume the rollers are massless.

- What are the kinetic and potential energies (pick a suitable datum) of the crate at the elevated platform, point A?
- What are the kinetic and potential energies of the cart at the end of the inclined plane just before it moves onto the horizontal conveyer, point B.
- Using conservation of energy, calculate the maximum speed attained by the crate at point B, assuming it starts moving from rest at point A.
- If the crate slides a distance x , say, on the horizontal conveyer, what is the energy lost to sliding in terms of μ , W , and x ?
- Calculate the value of the coefficient of friction, μ , such that the crate comes to rest at point C.

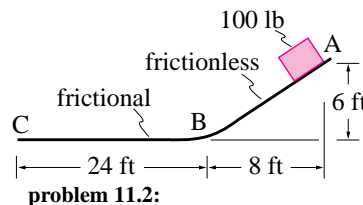

(Filename: pfigure.blue.30.1)

11.3 On a wintry evening, a student of mass m starts down the steepest street in town, *Steep Street*, which is of height h and slope θ . At the top of the slope she starts to slide (coefficient of dynamic friction μ).

- What is her initial kinetic and potential energy?
- What is the energy lost to friction as she slides down the hill?
- What is her velocity on reaching the bottom of the hill? Ignore air resistance and all cross streets (i.e. assume the hill is of constant slope).
- If, upon reaching the bottom of the street, she collides with another student of mass M and they embrace, what is their instantaneous mutual velocity just after the embrace?

- Assuming that friction still acts on the level flats on the bottom, how much time will it take before they come to rest?

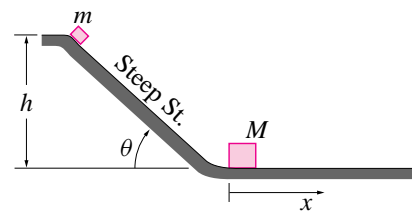

problem 11.3:

(Filename: pfigure.blue.25.2)

11.4 Reconsider the system of blocks in problem 3.30, this time with equal mass, $m_1 = m_2 = m$. Also, now, both blocks are frictional and sitting on a frictional surface. Assume that both blocks are sliding to the right with the top block moving faster. The coefficient of friction between the two blocks is μ_1 . The coefficient of friction between the lower block and the floor is μ_2 . It is known that $\mu_1 > 2\mu_2$.

- Draw free body diagrams of the blocks together and separately.
- Write the equations of linear momentum balance for each block.
- Find the acceleration of each block for the case of frictionless blocks. For the frictional blocks, find the acceleration of each block. What happens if $\mu_1 >> \mu_2$?

11.5 An initially motionless roller-coaster car of mass 20 kg is given a horizontal impulse $\int \mathbf{F} dt = P\mathbf{i}$ at position A, causing it to move along the track, as shown below.

- Assuming that the track is perfectly frictionless from point A to C and that the car never leaves the track, determine the magnitude of the impulse I so that the car "just makes it" over the hill at B.
- In the ensuing motion, assume that the horizontal track C - D is frictional and determine the coefficient of friction required to bring the car to a stop at D.

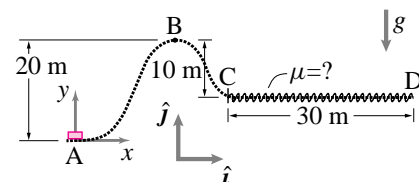

problem 11.5:

(Filename: pfigure.blue.21.2)

11.6 Masses $m_1 = 1$ kg and m_2 kg move on the frictionless varied terrain shown. Initially, m_1 has speed $v_1 = 12$ m/s and m_2 is at rest. The two masses collide on the flat section. The coefficient of restitution in the collision is $e = 0.5$. Find the speed of m_2 at the top of the first hill of elevation $h_1 = 1$ m. Does m_2 make it over the second hill of elevation $h_2 = 4$ m?

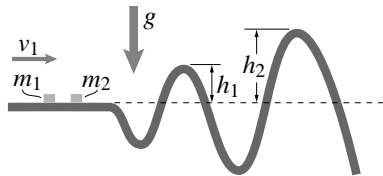

problem 11.6:

(Filename:DaneF94s2q7)

11.7 The two differential equations:

$$\begin{aligned} \ddot{R} - R\dot{\theta}^2 &= 0 \\ 2\dot{R}\dot{\theta} + R\ddot{\theta} &= 0 \end{aligned}$$

have the general solution

$$\begin{aligned} R &= \sqrt{d^2 + (v(t - t_0))^2} \\ \theta &= \theta_0 + \tan^{-1}(v(t - t_0)/d) \end{aligned}$$

where θ_0 , d , t_0 , and v are arbitrary constants. This solution could be checked by plugging back into the differential equations — you need not do this (tedious!) substitution. The solution describes a curve in the plane. That is, if for a range of values of t , the values of R and θ were calculated and then plotted using polar coordinates, a curve would be drawn. *What can you say about the shape of this curve?*

[Hints:

- Actually make a plot using some random values of the constants and see what the plot looks like.
- Write the equation $\mathbf{F} = m\mathbf{a}$ for a particle in polar coordinates and think of a force that would be relevant to this problem.
- The answer is something simple.]

11.8 A scotch yoke, a device for converting rotary motion into linear motion, is used to make a horizontal platform go up and down. The motion of the platform is $y = A \sin(\omega t)$ with constant ω . A dead bug with mass m is standing on the platform. Her feet have no glue on them. There is gravity.

- Draw a free body diagram of the bug.
- What is the acceleration of the platform and, hence, the bug?
- Write the equation of linear momentum balance for the bug.
- What condition must be met so that the bug does not bounce the platform?
- What is the maximum spin rate ω that can be used if the bug is not to bounce off the platform?

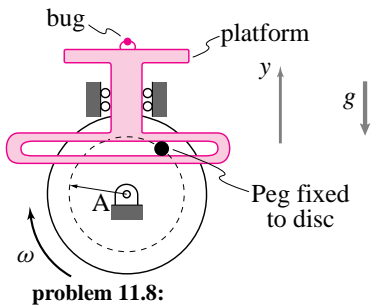

problem 11.8:

(Filename:pfigure.blue.34.1)

11.9 A new kind of gun. See also problems 11.10 and 11.11. Assume $\omega = \omega_0$ is a constant for the rod in the figure. Assume the mass is free to slide. At $t = 0$, the rod is aligned with the x -axis and the bead is one foot from the origin and has no radial velocity ($dR/dt = 0$).

- Find a differential equation for $R(t)$. *
- Turn this equation into a differential equation for $R(\theta)$. *
- How far will the bead have moved after one revolution of the rod? How far after two? *
- What is the speed of the bead after one revolution of the rod (use $\omega_0 = 2\pi$ rad/s = 1 rev/sec)? *
- How much kinetic energy does the bead have after one revolution and where did it come from? *

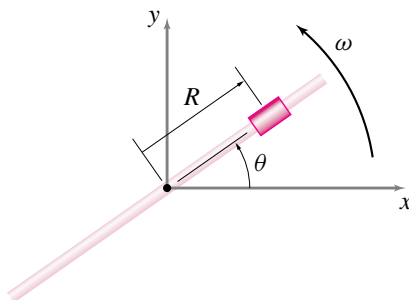

problem 11.9:

(Filename:pfigure.s94h9p5)

11.10 The new gun gets old and rusty. (See also problem 11.11.) Reconsider the bead on a rod in problem 11.9. This time, friction cannot be neglected. The friction coefficient is μ . At the instant of interest the bead with mass m has radius R_0 with rate of change \dot{R}_0 . The angle θ is zero and ω is a constant. Neglect gravity.

- What is \ddot{R} at this instant? Give your answer in terms of any or all of R_0 , \dot{R}_0 , ω , m , μ , \mathbf{e}_θ , \mathbf{e}_R , $\hat{\mathbf{i}}$, and $\hat{\mathbf{j}}$. *
- After a very long time it is observed that the angle ϕ between the path of the bead and the rod/trough is nearly constant. What, in terms of μ , is this ϕ ? *

11.11 (See also problem 11.10.) A newer kind of gun. As an attempt to make an improvement on the 'new gun' demonstrated in problem 11.9, a person adds a length ℓ_0 to the shaft on which the bead slides. Assume there is no friction between the bead (mass m) and the wire. Assume the bead starts at $l = 0$ with $\dot{l} = v_0$. The rigid rod, on which the bead slides, rotates at a constant rate $\omega = \omega_0$. Find $l(t)$ in terms of ℓ_0 , m , v_0 , and ω_0 .

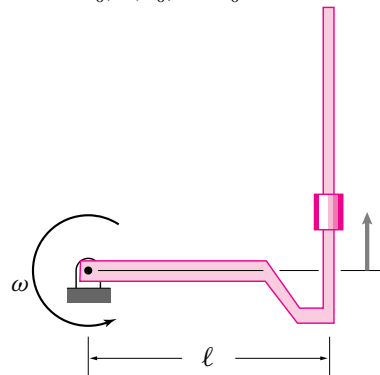

problem 11.11:

(Filename:pfigure.s94f1p5)

11.12 A bug of mass m walks straight-forwards with speed v_A and rate of change of speed \dot{v}_A on a straight light (assumed to be massless) stick. The stick is hinged at the origin so that it is always horizontal but is free to rotate about the z axis. Assume that the distance the bug is from the origin, ℓ , the angle the stick makes with the x axis, ϕ , and its rate of change, $\dot{\phi}$, are known at the instant of interest. Ignore gravity. Answer the following questions in terms of ϕ , $\dot{\phi}$, ℓ , m , v_A , and \dot{v}_A .

- What is $\ddot{\phi}$?
- What is the force exerted by the rod on the support?
- What is the acceleration of the bug?

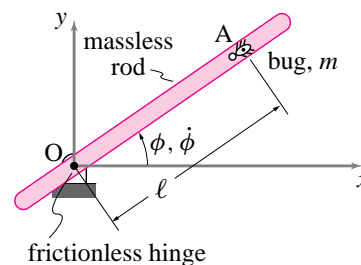

problem 11.12:

(Filename:pfigure.blue.55.1)

11.13 Slippery bead on straight rotating stick. A long stick with mass m_s rotates at a constant rate and a bead, modeled as a point mass, slides on the stick. The stick rotates at constant rate $\vec{\omega} = \omega \hat{\mathbf{k}}$. There is no gravity. The bead has mass m_b . Initially the mass is at a distance R_0 from the hinge point on the stick and has no radial velocity ($\dot{R} = 0$). The initial angle of the stick is θ_0 , measured counterclockwise from the positive x axis.

- a) What is the torque, as a function of the net angle the stick has rotated, $\theta - \theta_0$, required in order to keep the stick rotating at a constant rate?
- b) What is the path of the bead in the xy -plane? (Draw an accurate picture showing about one half of one revolution.)
- c) How long should the stick be if the bead is to fly in the negative x -direction when it gets to the end of the stick?
- d) **Add friction.** How does the speed of the bead over one revolution depend on μ , the coefficient of friction between the bead and the wire? Make a plot of $|\vec{v}_{\text{one revolution}}|$ versus μ . [Note, you have been working with $\mu = 0$ in the problems above.]
- e) **A finite rigid body.** What would change if instead of a point mass you modeled the bead as a finite rigid body (2-D), with center of mass on the stick, but contact at various places on the stick? (Do the frictionless case only.)

11.14 Mass on a lightly greased slotted turntable or spinning uniform rod. Assume that the rod/turntable in the figure is massless and also free to rotate. Assume that at $t = 0$, the angular velocity of the rod/turntable is 1 rad/s, that the radius of the bead is one meter, and that the radial velocity of the bead, dR/dt , is zero. The bead is free to slide on the rod. Where is the bead at $t = 5$ sec?

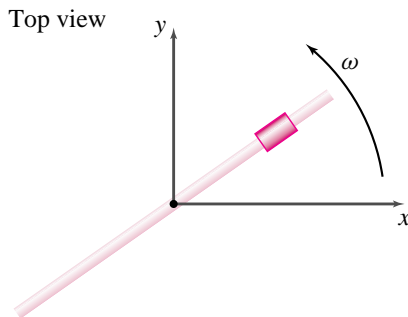
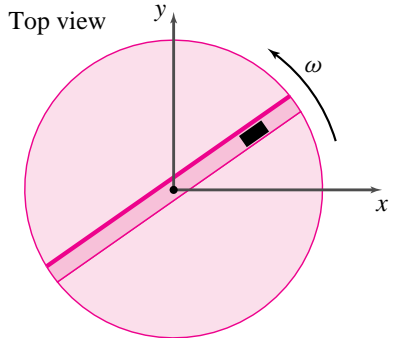

problem 11.14:

(Filename: pfigure.s94h9p4a)

11.15 A bead slides in a frictionless slot in a turntable. The turntable spins a constant rate ω . The slot is straight and goes through the center of the turntable. If the bead is at radius R_0 with

$\dot{R} = 0$ at $t = 0$, what are the components of the acceleration vector in the directions normal and tangential to the path of the bead after one revolution? Neglect gravity.

11.16 A bead of mass $m = 1$ gm bead is constrained to slide in a straight frictionless slot in a disk which is spinning counterclockwise at constant rate $\omega = 3$ rad/s per second. At time $t = 0$, the slot is parallel to the x -axis and the bead is in the center of the disk moving out (in the plus x direction) at a rate $\dot{R}_0 = .5$ m/s. After a net rotation θ of one and one eighth (1.125) revolutions, what is the force \vec{F} of the disk on the bead? Express this answer in terms of \hat{i} and \hat{j} . Make the unreasonable assumption that the slot is long enough to contain the bead for this motion.

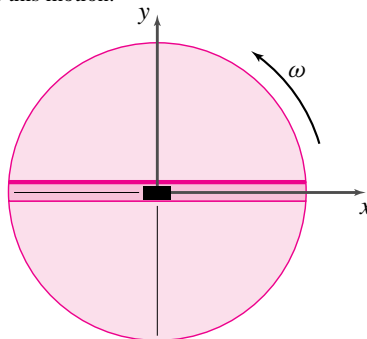

problem 11.16:

(Filename: pfigure.f93q11)

11.17 Bead on springy leash in a slot on a turntable. The bead in the figure is held by a spring that is relaxed when the bead is at the origin. The constant of the spring is k . The turntable speed is controlled by a strong stiff motor.

- a) Assume $\omega = 0$ for all time. What are possible motions of the bead?
- b) Assume $\omega = \omega_0$ is a constant. What are possible motions of the bead? Notice there are two cases depending on the value of ω_0 . What is going on here?

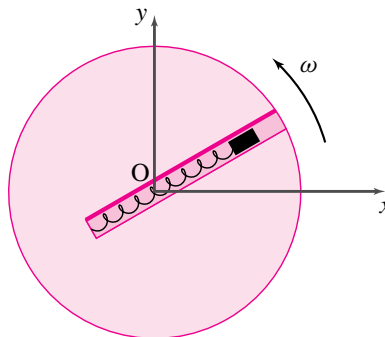

problem 11.17: Mass in a slot.

(Filename: pg57.1a)

11.18 A small bead with mass m slides without friction on a rigid rod which rotates about the z axis with constant ω (maintained by a stiff motor not shown in the figure). The bead is also attached to a spring with constant K , the

other end of which is attached to the rod. The spring is relaxed when the bead is at the center position. Assume the bead is released pulled to a distance d from the center of the rod and then released with an initial $\dot{R} = 0$. If needed, you may assume that $K > m\omega^2$.

- a) Derive the equation of motion for the position of the bead $R(t)$.
- b) How is the motion affected by large versus small values of K ?
- c) What is the magnitude of the force of the rod on the bead as the bead passes through the center position? Neglect gravity. Answer in terms of m, ω, d, K .
- d) Write an expression for the Coriolis acceleration. Give an example of a situation in which this acceleration is important and explain why it arises.

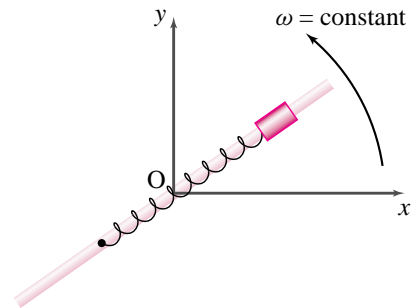

problem 11.18:

(Filename: pfigure.s94q9p1)

11.19 A small ball of mass $m_b = 500$ grams may slide in a slender tube of length $l = 1.2$ m. and of mass $m_t = 1.5$ kg. The tube rotates freely about a vertical axis passing through its center C . (Hint: Treat the tube as a slender rod.)

- a) If the angular velocity of the tube is $\omega = 8$ rad/s as the ball passes through C with speed relative to the tube, v_0 , calculate the angular velocity of the tube just before the ball leaves the tube. *
- b) Calculate the angular velocity of the tube just after the ball leaves the tube. *
- c) If the speed of the ball as it passes C is $v = 1.8$ m/s, determine the transverse and radial components of velocity of the ball as it leaves the tube. *
- d) After the ball leaves the tube, what constant torque must be applied to the tube (about its axis of rotation) to bring it to rest in 10 s? *

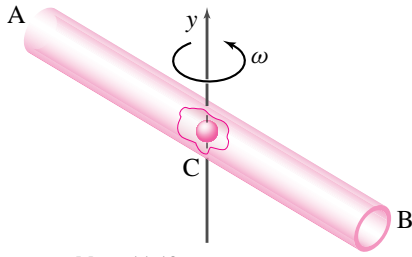

problem 11.19:

(Filename:pfigure.blue.91.1)

11.20 Toy train car on a turn-around. The 0.1 kg toy train's speedometer reads a constant 1 m/s when, heading west, it passes due north of point O . The train is on a level straight track which is mounted on a spinning turntable whose center is 'pinned' to the ground. The turntable spins at the constant rate of 2 rad/s . What is the force of the turntable on the train? (Don't worry about the z -component of the force.) *

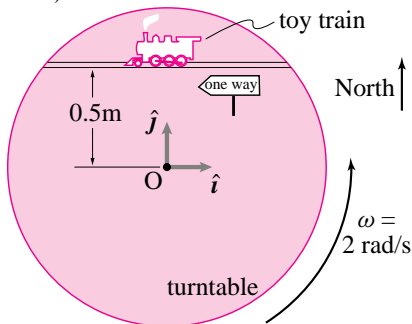

problem 11.20:

(Filename:pfigure.s94h12p1)

11.21 A shell moves down a barrel. At the instant of interest the barrel is being raised at a constant angular speed ω_1 . Simultaneously the gun turret (the structure which holds the barrel) rotates about the vertical axis at a constant rate ω_2 . At the instant of interest, the barrel is tipped up an angle θ and the mass m is moving at speed v along the frictionless barrel. Neglecting gravity, find the force of the barrel on the shell.

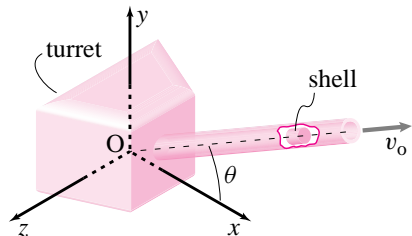

problem 11.21: A shell moves along a canon barrel.

(Filename:pg122.2)

11.22 Due to forces not shown, the cart moves to the right with constant acceleration a_x . The ball B has mass m_B . At time $t = 0$, the string AB is cut. Find

- the tension in string BC before cutting, *

- the absolute acceleration of the mass at the instant of cutting, *
- the tension in string BC at the instant of cutting. *

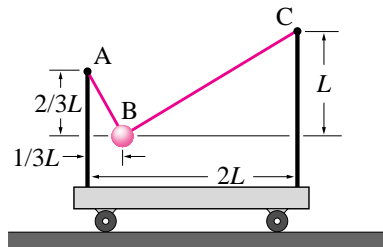

problem 11.22:

(Filename:Dane94s1q6)

11.23 The forked arm mechanism pushes the bead of mass 1 kg along a frictionless hyperbolic spiral track given by $r = 0.5\theta$ (m/rad). The arm rotates about its pivot point at O with constant angular acceleration $\ddot{\theta} = 1\text{ rad/s}^2$ driven by a motor (not shown). The arm starts from rest at $\theta = 0^\circ$.

- Determine the radial and transverse components of the acceleration of the bead after 2 s have elapsed from the start of its motion.
- Determine the magnitude of the net force on the mass at the same instant in time.

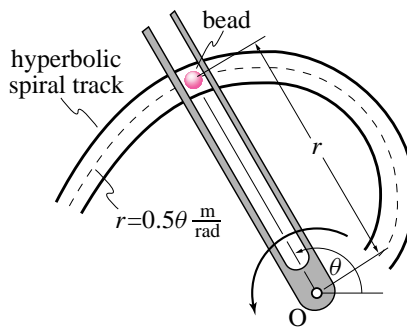

problem 11.23:

(Filename:pfigure.blue.53.1)

11.24 A rod is on the palm of your hand at point A . Its length is ℓ . Its mass m is assumed to be concentrated at its end at C . Assume that you know θ and $\dot{\theta}$ at the instant of interest. Also assume that your hand is accelerating both vertically and horizontally with $\vec{a}_{\text{hand}} = a_{hx}\hat{i} + a_{hy}\hat{j}$. Coordinates and directions are as marked in the figure.

- Draw a Free Body Diagram of the rod.
- Assume that the hand is stationary. Solve for $\ddot{\theta}$ in terms of g, ℓ, m, θ , and $\dot{\theta}$.
- If the hand is not stationary but $\ddot{\theta}$ has been determined somehow, find the vertical force of the hand on the rod in terms of $\dot{\theta}, \theta, g, \ell, m, a_{hx}$, and a_{hy} .

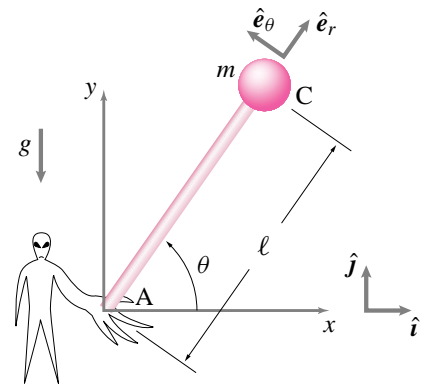

problem 11.24: Rod on a Moving Support(2-D).

(Filename:p3.1)

11.25 Balancing a broom. Assume the hand is accelerating to the right with acceleration $\mathbf{a} = a\hat{i}$. What is the force of the hand on the broom in terms of $m, \ell, \theta, \dot{\theta}, a, \hat{i}, \hat{j}$, and g ? (You may not have any \hat{e}_R or \hat{e}_θ in your answer.)

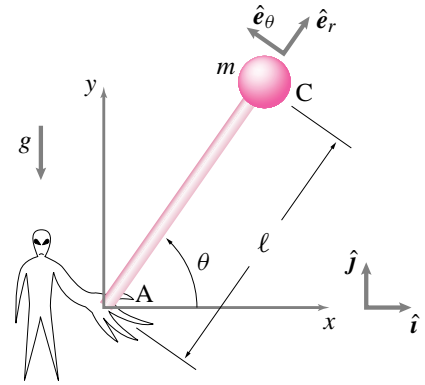

problem 11.25:

(Filename:p.f96.f.2)

11.2 Dynamics of rigid bodies in one-degree-of-freedom mechanisms

11.26 A conservative vibratory system has the following equation of conservation of energy.

$$m(L\dot{\theta})^2 - mgL(1 - \cos \theta) + K(a\theta)^2 = \text{Constant}$$

- Obtain the differential equation of motion of this system by differentiating this energy equation with respect to t .
- Determine the circular frequency of small oscillations of the system in part (a). HINT: (Let $\sin \theta \cong \theta$ and $\cos \theta \cong 1 - \theta^2/2$).

11.27 A motor at O turns at rate ω_o whose rate of change is $\dot{\omega}_o$. At the end of a stick connected to this motor is a frictionless hinge attached to a second massless stick. Both sticks have length L . At the end of the second stick is a mass

m . For the configuration shown, what is $\ddot{\theta}$? Answer in terms of ω_o , $\dot{\omega}_o$, L , m , θ , and $\dot{\theta}$. Ignore gravity.

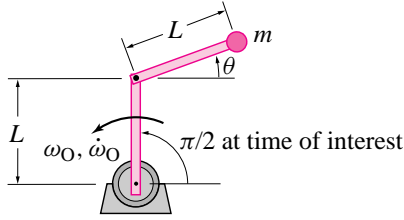

problem 11.27: (Filename:pfimage.blue.119.1)

11.28 (See also problems 10.31 and 10.35.) In problem 9.12, find

- the angular momentum about point O , *
- the rate of change of angular momentum of the disk about point O , *
- the angular momentum about point C , *
- the rate of change of angular momentum of the disk about point C . *

Assume the rod is massless and the disk has mass m .

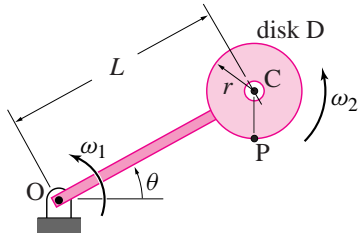

problem 11.28: (Filename:doublerot.ang.mom)

11.29 Robot arm, 2-D . The robot arm AB is rotating about point A with $\omega_{AB} = 5 \text{ rad/s}$ and $\dot{\omega}_{AB} = 2 \text{ rad/s}^2$. Meanwhile the forearm BC is rotating at a constant angular speed with respect to AB of $\omega_{BC/AB} = 3 \text{ rad/s}$. Gravity cannot be neglected. At the instant shown, find the net force acting on the object P which has mass $m = 1 \text{ kg}$. *

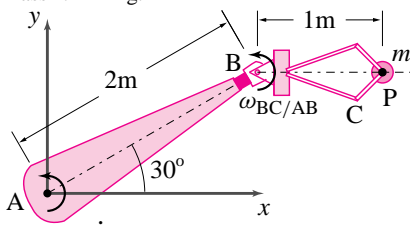

problem 11.29: (Filename:pfimage.s94h12p5)

11.30 A crude model for a column, shown in the figure, consists of two identical rods of mass m and length ℓ with hinge connections, a linear torsional spring of stiffness K attached to the center hinge (the spring is relaxed when $\theta = 0$), and a load P applied at the top end.

- Obtain the exact nonlinear equation of motion.

- Obtain the squared natural frequency for small motions θ .
- Check the stability of the straight equilibrium state $\theta = 0$ for all $P \geq 0$ via minimum potential energy. How do these results compare with those from part(b)?

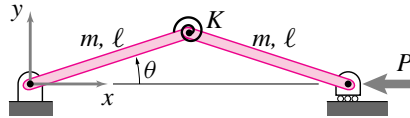

problem 11.30: (Filename:pfimage.blue.159.2)

11.31 A thin uniform rod of mass m rests against a frictionless wall and on a frictionless floor. There is gravity.

- Draw a free body diagram of the rod.
- The rod is released from rest at $\theta = \theta_0 \neq 0$. Write the equation of motion of the rod. *
- Using the equation of motion, find the initial angular acceleration, $\dot{\omega}_{AB}$, and the acceleration of the center of mass, \vec{a}_G , of the rod. *
- Find the reactions on the rod at points A and B . *
- Find the acceleration of point B . *
- When $\theta = \frac{\theta_0}{2}$, find $\vec{\omega}_{AB}$ and the acceleration of point A . *

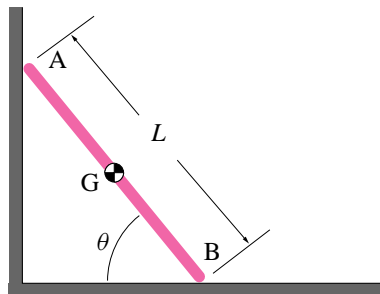

problem 11.31: (Filename:ch7.1)

11.32 Bar leans on a crooked wall. A uniform 3 lbf bar leans on a wall and floor and is let go from rest. Gravity pulls it down.

- Draw a Free Body Diagram of the bar.
- Kinematics: find the velocity and acceleration of point B in terms of the velocity and acceleration of point A
- Using equations of motion, find the acceleration of point A .
- Do the reaction forces at A and B add up to the weight of the bar? Why or why not? (You do not need to solve for the reaction forces in order to answer this part.)

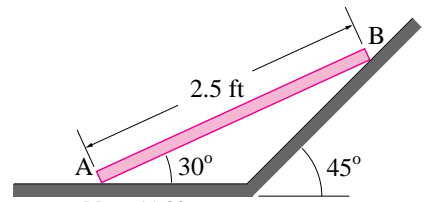

problem 11.32: (Filename:pfimage.s94h10p3)

11.33 Two blocks, each with mass m , slide without friction on the wall and floor shown. They are attached with a rigid massless rod of length ℓ that is pinned at both ends. The system is released from rest when the rod makes an angle of 45° . What is the acceleration of the block B immediately after the system is released?

$$m_A = m_B = m$$

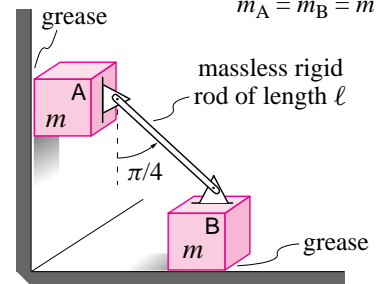

problem 11.33: (Filename:pfimage.blue.98.2)

11.34 Slider Crank. 2-D . No gravity. Refer to the figure in problem 10.19. What is the tension in the massless rod AB (with length L) when the slider crank is in the position with $\theta = 0$ (piston is at maximum extent)? Assume the crankshaft has constant angular velocity ω , that the connecting rod AB is massless, that the cylinder walls are frictionless, that there is no gas pressure in the cylinder, that the piston has mass M and the crank has radius R .

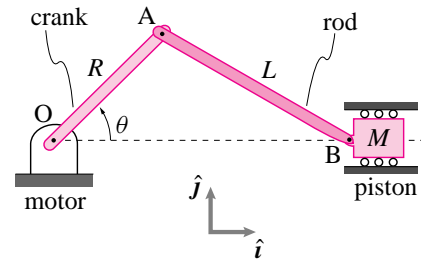

problem 11.34: (Filename:slidercrank.tension)

11.35 In problem 10.25, find the force on the wheel at point D due to the rod.

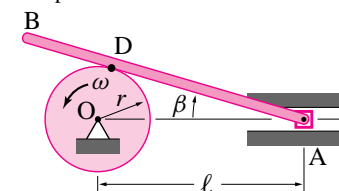

problem 11.35: (Filename:roddisc.force)

11.36 In problem 10.26, find the force on the rod at point P.

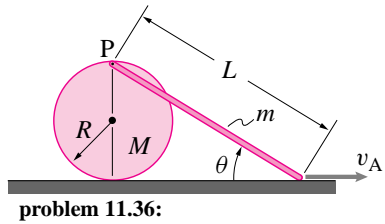

problem 11.36:

(Filename:rodcyl.force)

11.37 Slider-Crank mechanism. The slider crank mechanism shown is used to push a 2 lbf block P. Arm AB and BC are each 0.5 ft long. Given that arm AB rotates counterclockwise at a constant 2 revolutions per second, what is the force on P at the instant shown? *

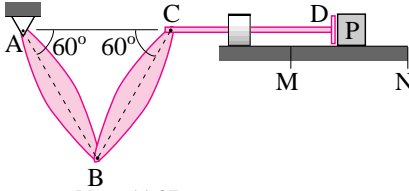

problem 11.37:

(Filename:pfigure.s94h11p1)

11.38 Consider the 4-bar linkage AB, BC, CD and the ground DA. The bars are connected by well lubricated hinges at A, B, and C. At D, bar CD is driven by the motor which spins at constant rate. Do not ignore gravity.

- Draw a Free Body Diagram of the linkage ABCD (with 'cuts' at A and D but not at B and C.)
- Draw Free Body Diagrams of each of the bars AB, BC and CD. Use the law of action and reaction in these diagrams. If you can, do this problem a few times, each with a different vector notation.
- Repeat problem (b) but this time assume that the mass of bar BC is negligible. [Hint, this implies that the laws of statics apply to bar BC, which has connections at the two points B and C.]

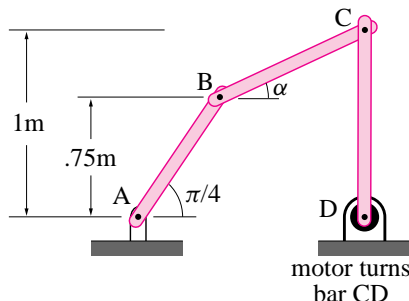

problem 11.38: Free Body Diagram Exercise

(Filename:pfigure.s94h2p7)

11.39 The large masses m at C and A were supported by the light triangular plate ABC, whose corners follow the guide. B enters the curved guide with velocity V . Neglecting gravity, find the vertical reactions (in the y direction) at A

and B. (Hint: for the rigid planar body ABC, find \ddot{y}_A and \ddot{y}_B in terms of a_y^{cm} and $\ddot{\theta}$, assuming $\dot{\theta} = 0$ initially.)

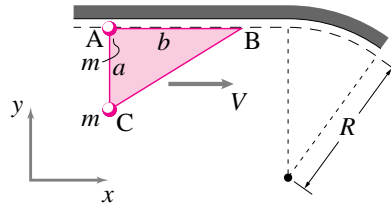

problem 11.39:

(Filename:pfigure.blue.85.2)

11.40 An idealized model for a car comprises a rigid chassis of mass M_c and four identical rigid disks (wheels) of mass M_w and radius R , as shown in the figure. Initially in motion with speed v_0 , the car is momentarily brought to rest by compressing an initially uncompressed spring of stiffness k . Assume no frictional losses.

- Assuming no wheel slip, determine the compression Δ of the spring required to stop the car. *
- While the car is in contact with the spring but still moving forward, in which direction is the *tangential* force on any one of the wheels (due to contact with the ground) pointing? Why? (Illustrate with a sketch). *
- Repeat part (a) assuming now that the ground is perfectly frictionless from points A to B shown in the figure. *

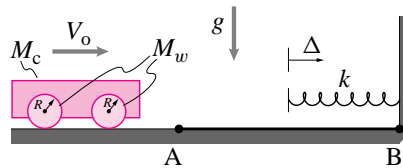

problem 11.40:

(Filename:pfigure.blue.135.2)

11.41 While walking down a flat stretch of road you see a dejected Greg Lemond riding by. His riding "tuck" is so good that you realize that you can totally neglect air resistance when you think about him and his bike. Further, you can regard his and the bike's combined mass (all 70 kg) as concentrated at a point in his stomach somewhere. Greg's left foot has just fallen off the pedal so he is only pedaling with his right foot, which at the moment in question is at its lowest point in the motion. You note that, relative to the ground the right foot is only going 3/4 as fast as the bike (since it is going backwards relative to the bike), though you can't make out all the radii of his frictionless gears and rigid round wheels. Greg, ever in touch with his body, tells you he is pushing back on the pedal with a force of 70 N. You would like to know Greg's acceleration.

- In your first misconceived experiment you set up a 70 kg bicycle in your laboratory and balance it with strings that cause no fore or aft forces. You tie a string to the vertically down right pedal and pull back with a force of 70 N. What acceleration do you measure?
- What is Greg's actual acceleration? [Hint: Greg's massless leg is pushing forward on his body with a force of 70 N]

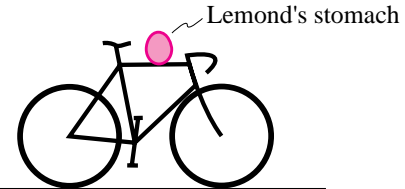

problem 11.41:

(Filename:pfigure.blue.34.2)

11.42 Which way does the bike accelerate?

A bicycle with all frictionless bearings is standing still on level ground. A horizontal force F is applied on one of the pedals as shown. There is no slip between the wheels and the ground. The bicycle is gently balanced on falling over sideways. It is heavy enough so that both wheels stay on the ground. Does the bicycle accelerate forward, backward, or not at all? Make any reasonable assumptions about the dimensions and mass. Justify your answer as clearly as you can, clearly enough to convince a person similar to yourself but who has not seen the experiment performed.

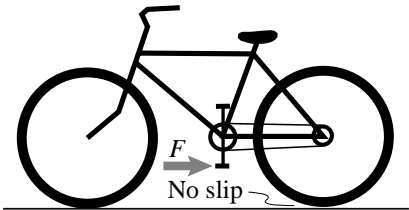

problem 11.42:

(Filename:pfigure.s94h14p2)

11.3 Dynamics of multi-degree-of-freedom mechanisms

11.43 Particle on a springy leash. A particle with mass m slides on a rigid horizontal frictionless plane. It is held by a string which is in turn connected to a linear elastic spring with constant k . The string length is such that the spring is relaxed when the mass is on top of the hole in the plane. The position of the particle is $\mathbf{r} = x\hat{i} + y\hat{j}$. For each of the statements below, state the circumstances in which the statement is true (assuming the particle stays on the plane). Justify your answer with convincing explanation and/or calculation.

- a) The force of the plane on the particle is $mg\hat{k}$.
- b) $\ddot{x} + \frac{k}{m}x = 0$
- c) $\ddot{y} + \frac{k}{m}y = 0$
- d) $\ddot{r} + \frac{k}{m}r = 0$, where $r = |\vec{r}|$
- e) $r = \text{constant}$
- f) $\dot{\theta} = \text{constant}$
- g) $r^2\dot{\theta} = \text{constant}$.
- h) $m(\dot{x}^2 + \dot{y}^2) + kr^2 = \text{constant}$
- i) The trajectory is a straight line segment.
- j) The trajectory is a circle.
- k) The trajectory is not a closed curve.

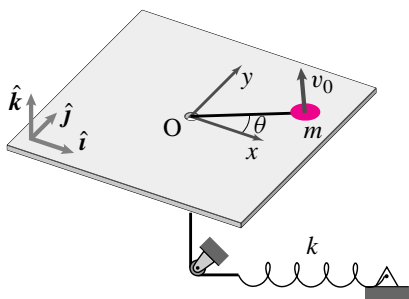

problem 11.43: Particle on a springy leash.

(Filename:pg69.1)

11.44 “Yo-yo” mechanism of satellite de-spinning. A satellite, modeled as a uniform disk, is “de-spun” by the following mechanism. Before launch two equal length long strings are attached to the satellite at diametrically opposite points and then wound around the satellite with the same sense of rotation. At the end of the strings are placed 2 equal masses. At the start of de-spinning the two masses are released from their position wrapped against the satellite. Find the motion of the satellite as a function of time for the two cases: (a) the strings are wrapped in the same direction as the initial spin, and (b) the strings are wrapped in the opposite direction as the initial spin.

11.45 A particle with mass m is held by two long springs each with stiffness k so that the springs are relaxed when the mass is at the origin. Assume the motion is planar. Assume that the particle displacement is much smaller than the lengths of the springs.

- a) Write the equations of motion in cartesian components. *
- b) Write the equations of motion in polar coordinates. *
- c) Express the conservation of angular momentum in cartesian coordinates. *
- d) Express the conservation of angular momentum in polar coordinates. *
- e) Show that (a) implies (c) and (b) implies (d) even if you didn’t note them *a-priori*. *

- f) Express the conservation of energy in cartesian coordinates. *
- g) Express the conservation of energy in polar coordinates. *
- h) Show that (a) implies (f) and (b) implies (g) even if you didn’t note them *a-priori*. *
- i) Find the general motion by solving the equations in (a). Describe all possible paths of the mass. *
- j) Can the mass move back and forth on a line which is not the x or y axis? *

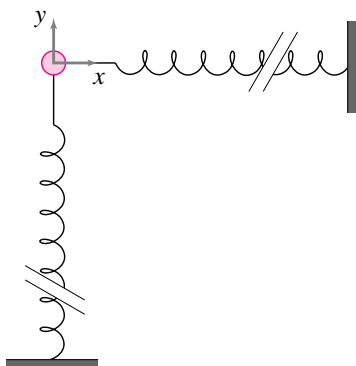

problem 11.45:

(Filename:pfigure.blue.73.1)

11.46 Cart and pendulum A mass $m_B = 6$ kg hangs by two strings from a cart with mass $m_C = 12$ kg. Before string BC is cut string AB is horizontal. The length of string AB is $r = 1$ m. At time $t = 0$ all masses are stationary and the string BC is cleanly and quietly cut. After some unknown time t_{vert} the string AB is vertical.

- a) What is the net displacement of the cart x_C at $t = t_{\text{vert}}$? *
- b) What is the velocity of the cart v_C at $t = t_{\text{vert}}$? *
- c) What is the tension in the string at $t = t_{\text{vert}}$? *
- d) (Optional) What is $t = t_{\text{vert}}$? [You will either have to leave your answer in the form of an integral you cannot evaluate analytically or you will have to get part of your solution from a computer.]

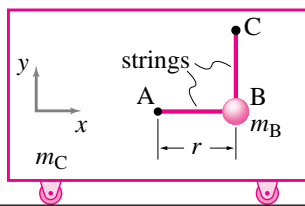

problem 11.46:

(Filename:pfigure.s94h12p3)

11.47 A dumbbell slides on a floor. Two point masses m at A and B are connected by a massless rigid rod with length ℓ . Mass B slides on a frictionless floor so that it only moves horizontally. Assume this dumbbell is released from

rest in the configuration shown. [Hint: What is the acceleration of A relative to B?]

- a) Find the acceleration of point B just after the dumbbell is released.
- b) Find the velocity of point A just before it hits the floor

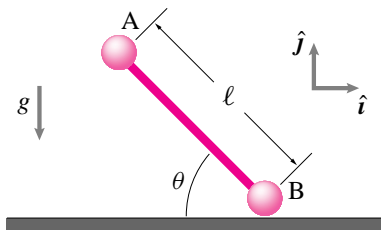

problem 11.47:

(Filename:s97f5)

11.48 After a winning goal one second before the clock ran out a psychologically stunned hockey player (modeled as a uniform rod) stands nearly vertical, stationary and rigid. The players perfectly slippery skates start to pop out from under her as she falls. Her height is ℓ , her mass m , her tip from the vertical θ , and the gravitational constant is g .

- a) What is the path of her center of mass as she falls? (Show clearly with equations, sketches or words.)
- b) What is her angular velocity just before she hits the ice, a millisecond before she sticks our her hands and brakes her fall (first assume her skates remain in contact the whole time and then check the assumption)?
- c) Find a differential equation that only involves θ , its time derivatives, m , g , and ℓ . (This equation could be solved to find θ as a function of time. It is a non-linear equation and you are not being asked to solve it numerically or otherwise.)

11.49 Falling hoop. A bicycle rim (no spokes, tube, tire, or hub) is idealized as a hoop with mass m and radius R . G is at the center of the hoop. An inextensible string is wrapped around the hoop and attached to the ceiling. The hoop is released from rest at the position shown at $t = 0$.

- a) Find y_G at a later time t in terms of any or all of m , R , g , and t .
- b) Does G move sideways as the hoop falls and unrolls?

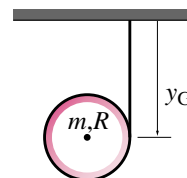

problem 11.49:

(Filename:p.s96.p3.2)

11.50 A model for a yo-yo comprises a thin disk of mass M and radius R and a light drum of radius r , rigidly attached to the disk, around which a light inextensible cable is wound. Assuming that the cable unravels without slipping on the drum, determine the acceleration a_G of the center of mass.

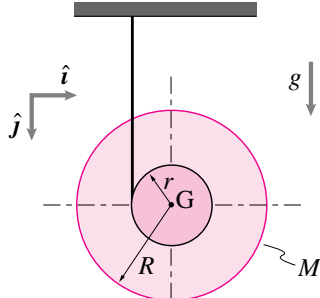

problem 11.50:

(Filename:pfigure.blue.41.2)

11.51 A uniform rod with mass m_R pivots without friction about point A in the xy -plane. A collar with mass m_C slides without friction on the rod after the string connecting it to point A is cut. There is no gravity. Before the string is cut, the rod has angular velocity ω_1 .

- What is the speed of the collar after it flies off the end of the rod? Use the following values for the constants and initial conditions: $m_R = 1$ kg, $m_C = 3$ kg, $a = 1$ m, $\ell = 3$ m, and $\omega_1 = 1$ rad/s
- Consider the special case $m_R = 0$. Sketch (approximately) the path of the motion of the collar from the time the string is cut until some time after it leaves the end of the rod.

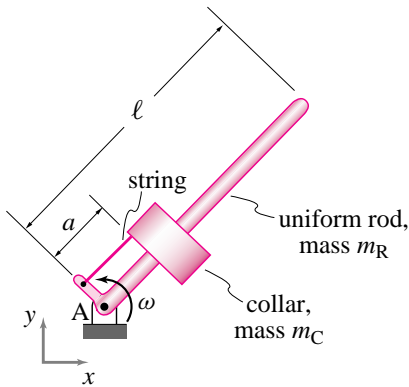

problem 11.51:

(Filename:pfigure.blue.54.1)

11.52 (See also problem 11.53.) Assume the rod in the figure for problem 10.29 has polar moment of inertia I_{ozz} . Assume it is free to rotate. The bead is free to slide on the rod. Assume that at $t = 0$ the angular velocity of the rod is 1 rad/s, that the radius of the bead is one meter and that the radial velocity of the bead, dR/dt , is zero.

- Draw separate free body diagrams of the bead and rod.
- Write equations of motion for the system. *
- Use the equations of motion to show that angular momentum is conserved. *
- Find one equation of motion for the system using: (1) the equations of motion for the bead and rod and (2) conservation of angular momentum. *
- Write an expression for conservation of energy. Let the initial total energy of the system be, say, E_0 . *
- As t goes to infinity does the bead's distance go to infinity? Its speed? The angular velocity of the turntable? The net angle of twist of the turntable? *

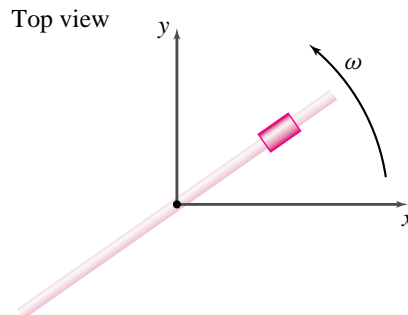
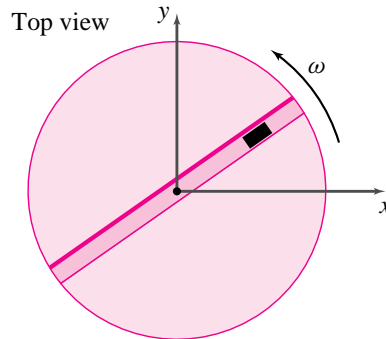

problem 11.52: Coupled motion of bead and rod and turntable.

(Filename:pfigure.s94h9p4b.a)

11.53 Numerically simulate the coupled system in problem 11.52. Use the simulation to show that the net angle of the turntable or rod is finite.

- Write the equations of motion for the system from part (b) in problem 11.52 as a set of first order differential equations. *
- Numerically integrate the equations of motion. (Below, we show a solution using MATLAB.)

```
%newgunscript.m quiz 13 soln - A Ruina 4/27/95
z0 = [0,3,1,0]; % [Theta, omega, R, v]
tfinal = 10000 ;
tol = 1e-7 ;

[t,z] = ode45('newgunfun', 0, tfinal, z0, tol);
thetamax=max(z(:,1));

plot(log10(t),z(:,1));
title('andys plot'); xlabel('log10 (time)');
ylabel('theta');
axis([-5, log10(tfinal), 0 3])

text(-4.5,2.5,['theta max= ',num2str(thetamax,9)])
text(-4.5,2.25,['tol = ',num2str(tol,9)])
text(-4.5,2,['tfinal = ',num2str(tfinal,9)])
```

```
function zdot=newgunfun(t,z)
m=.25; I=2;

theta = z(1);
omega = z(2);
R = z(3);
v = z(4);

zdot = [ omega,
        -2*m*omega*R*v/(I + m*R^2),
        v,
        omega^2*R
        ];
```

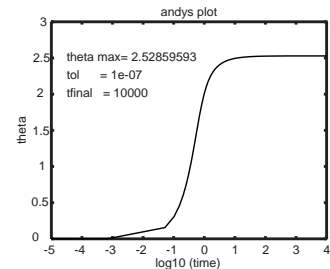

problem 11.53:

(Filename:q13soln)

11.54 A primitive gun rides on a cart (mass M) and carries a cannon ball (of mass m) on a platform at a height H above the ground. The cannon ball is dropped through a frictionless tube shaped like a quarter circle of radius R .

- If the system starts from rest, compute the horizontal speed (relative to the ground) that the cannon ball has as it leaves the bottom of the tube. Also find the cart's speed at the same instant.
- Compute the velocity of the cannon ball relative to the cart.
- If two balls are dropped simultaneously through the tube, what speed does the cart have when the balls reach the bottom? Is the same final speed also achieved if one ball is allowed to depart the system entirely before the second ball is released? Why/why not?

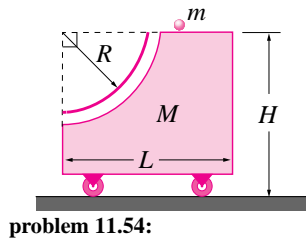

problem 11.54:

(Filename:pfigure.blue.18.1)

11.55 Two frictionless prisms of similar right triangular sections are placed on a frictionless horizontal plane. The top prism weighs W and the lower one nW . The prisms are held in the initial position shown and then released, so that the upper prism slides down along the lower one until it just touches the horizontal plane. The center of mass of a triangle is located at one-third of its height from the base. Compute the **velocities** of the two prisms at the moment just before the upper one reaches the bottom. *

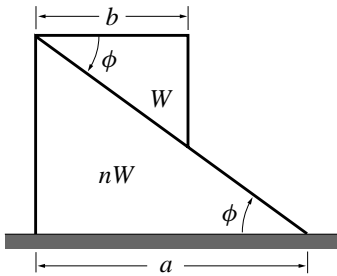

problem 11.55:

(Filename:pfigure.blue.28.2a)

11.56 Mass slides on an accelerating cart.
2D. A cart is driven by a powerful motor to move along the 30° sloped ramp according to the formula: $d = d_0 + v_0 t + a_0 t^2/2$ where d_0 , v_0 , and a_0 are given constants. The cart is held from tipping over. The cart itself has a 30° sloped upper surface on which rests a mass (given mass m). The surface on which the mass rests is frictionless. Initially the mass is at rest with regard to the cart.

- What is the force of the cart on the mass? [in terms of g , d_0 , v_0 , t , a_0 , m , g , \hat{i} , and \hat{j} .] *
- For what values of d_0 , v_0 , t and a_0 is the acceleration of the mass exactly vertical (i.e., in the \hat{j} direction)? *

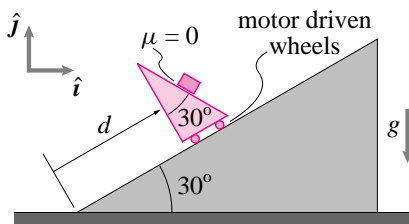

problem 11.56:

(Filename:pfigure.s95q11)

11.57 A thin rod AB of mass $W_{AB} = 10$ lbm and length $L_{AB} = 2$ ft is pinned to a cart C of mass $W_C = 10$ lbm, the latter of which is free to move along a frictionless horizontal surface, as shown in the figure. The system is released from rest with the rod in the horizontal position.

- Determine the angular speed of the rod as it passes through the vertical position (at some later time). *
- Determine the displacement x of the cart at the same instant. *
- After the rod passes through vertical, it is momentarily horizontal but on the left side of the cart. How far has the cart moved when this configuration is reached?

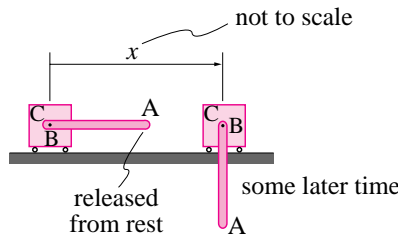

problem 11.57:

(Filename:pfigure.blue.115.3)

11.58 As shown in the figure, a block of mass m rolls without friction on a rigid surface and is at position x (measured from a fixed point). Attached to the block is a uniform rod of length ℓ which pivots about one end which is at the center of mass of the block. The rod and block have equal mass. The rod makes an angle θ with the vertical. Use the numbers below for the values of the constants and variables at the time of interest:

$$\begin{aligned} \ell &= 1 \text{ m} \\ m &= 2 \text{ kg} \\ \theta &= \pi/2 \\ d\theta/dt &= 1 \text{ rad/s} \\ d^2\theta/dt^2 &= 2 \text{ rad/s}^2 \\ x &= 1 \text{ m} \\ dx/dt &= 2 \text{ m/s} \\ d^2x/dt^2 &= 3 \text{ m/s}^2 \end{aligned}$$

- What is the kinetic energy of the system?
- What is the linear momentum of the system (momentum is a vector)?

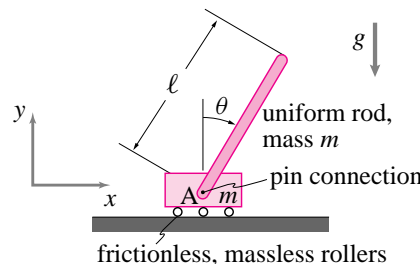

problem 11.58:

(Filename:pfigure.blue.14.1)

11.59 A pendulum of length ℓ hangs from a cart. The pendulum is massless except for a point mass of mass m_p at the end. The cart rolls without friction and has mass m_c . The cart is initially stationary and the pendulum is released from rest at an angle θ . What is the acceleration of the cart just after the mass is released? [Hints: $\mathbf{a}_P = \mathbf{a}_C + \mathbf{a}_{P/C}$. The answer is $\mathbf{a}_C = (g/3)\hat{i}$ in the special case when $m_p = m_c$ and $\theta = \pi/4$.]

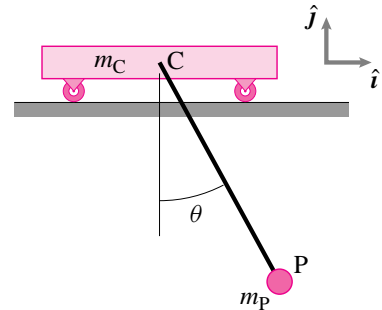

problem 11.59:

(Filename:pfigure.f93q12)

11.60 Due to the application of some unknown force F , the base of the pendulum A is accelerating with $\mathbf{a}_A = a_A \hat{i}$. There is a frictionless hinge at A. The angle of the pendulum θ with the x axis and its rate of change $\dot{\theta}$ are assumed to be known. The length of the massless pendulum rod is ℓ . The mass of the pendulum bob M . There is no gravity. What is $\ddot{\theta}$? (Answer in terms of a_A , ℓ , M , θ and $\dot{\theta}$.)

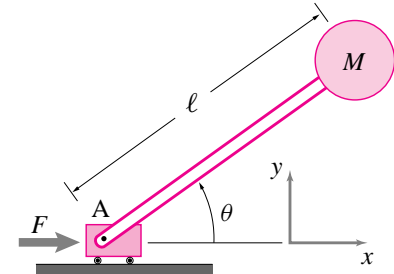

problem 11.60:

(Filename:pfigure.blue.115.2)

11.61 Pumping a Swing Can a swing be pumped by moving the support point up and down?

For simplicity, neglect gravity and consider the problem of swinging a rock in circles on a string. Let the rock be mass m attached to a string of fixed length ℓ . Can you speed it up by moving your hand up and down? How? Can you make a quantitative prediction? Let x_S be a function of time that you can specify to try to make the mass swing progressively faster.

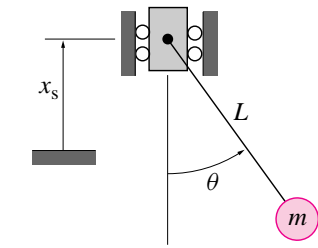

problem 11.61: (Filename: pfigure.blue.59.1)

11.62 Using free body diagrams and appropriate momentum balance equations, find differential equations that govern the angle θ and the vertical deflection y of the system shown. Be clear about your datum for y . Your equations should be in terms of θ , y and their time-derivatives, as well as M , m , ℓ , and g .

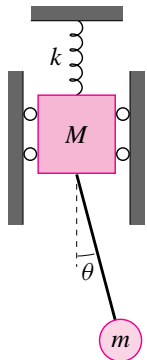

problem 11.62: (Filename: pfig2.1.rp11)

11.63 The two blocks shown are released from rest at $t = 0$. There is no friction and the cable is initially taut. (a) What is the tension in the cable immediately after release? (Use any reasonable value for the gravitational constant). (b) What is the tension after 5 s?

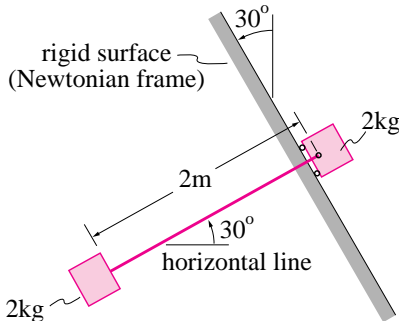

problem 11.63: (Filename: pfigure.blue.18.2)

11.64 Carts A and B are free to move along a frictionless horizontal surface, and bob C is connected to cart B by a massless, inextensible cord of length ℓ , as shown in the figure. Cart A moves to the left at a constant speed $v_0 = 1 \text{ m/s}$ and makes a perfectly plastic collision ($e = 0$) with cart B which, together with bob C, is stationary prior to impact. Find the maximum vertical position of bob C, h_{max} , after impact. The masses of the carts and pendulum bob are $m_A = m_B = m_C = 10 \text{ kg}$.

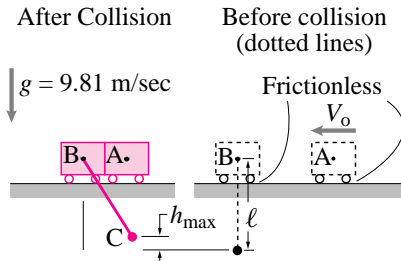

problem 11.64: (Filename: pfigure.blue.137.3)

11.65 See also problem 3.29. A double pendulum is made of two uniform rigid rods, each of length ℓ . The first rod is massless. Find equations of motion for the second rod. Define any variables you use in your solution.

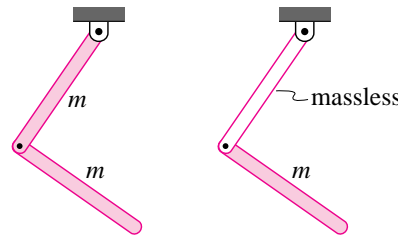

problem 11.65: (Filename: pfig2.1.rp10)

11.66 A model of walking involves two straight legs. During the part of the motion when one foot is on the ground, the system looks like the picture in the figure, confined to motion in the $x - y$ plane. Write two equations from which one could find $\dot{\theta}_1$, and $\dot{\theta}_2$ given $\theta_1, \theta_2, \dot{\theta}_1, \dot{\theta}_2$ and all mass and length quantities.

Hint:

$$\begin{bmatrix} \sum \vec{M}_{/A} = \dot{\vec{H}}_{/A} & \text{whole system} \\ \sum \vec{M}_{/B} = \dot{\vec{H}}_{/B} & \text{for bar BC} \end{bmatrix}$$

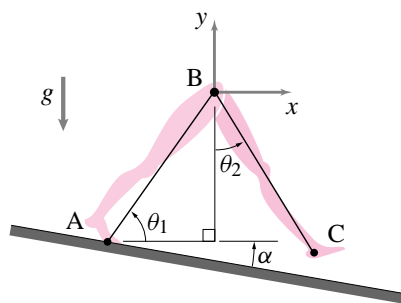

problem 11.66: (Filename: pfigure.blue.100.1)

11.4 Advanced problems in 2D motion

11.67 A pendulum is hanging from a moving support in the xy -plane. The support moves in a known way given by $\vec{r}(t) = r(t)\hat{l}$. For the following cases, find a differential equation whose solution would determine $\theta(t)$, measured clockwise from vertical; then find an expression for $d^2\theta/dt^2$ in terms of θ and $r(t)$:

- with no gravity and assuming the pendulum rod is massless with a point mass of mass m at the end,
- as above but with gravity,
- assuming the pendulum is a uniform rod of mass m and length ℓ .

11.68 Robotics problem: balancing a broom stick by sideways motion. See also problem 7.99 and problem 8. Try to balance a broom stick by moving your hand horizontally. Model your hand contact with the broom as a hinge. You can model the broom as a uniform stick or as a point mass at the end of a stick — your choice.

- Equation of motion.** Given the acceleration of your hand (horizontal only), the current tip, and the rate of tip of the broom, find the angular acceleration of the broom. *
- Control?** Can you find a hand acceleration in terms of the tip and the tip rate that will make the broom balance upright? *

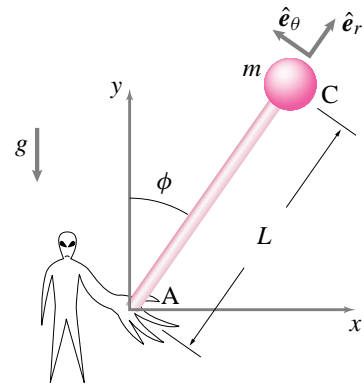

problem 11.68: (Filename: pfigure.s94h10p5)

11.69 Balancing the broom again: vertical shaking works too. You can balance a broom by holding it at the bottom and applying appropriate torques, as in problem 7.99 or by moving your hand back and forth in an appropriate manner, as in problem 11.68. In this problem, you will try to balance the broom differently. The lesson to be learned here is more subtle, and you should probably just wonder at it rather than try to understand it in detail.

In the previous balancing schemes, you used knowledge of the state of the broom (θ and $\dot{\theta}$) to determine what corrective action to apply. Now balance the broom by moving it in a way that ignores what the broom is doing. In the language of robotics, what you have been doing before is ‘closed-loop feedback’ control. The new strategy, which is simultaneously more simple minded and more subtle, is an ‘open loop’ control. Imagine that your hand connection to the broom is a hinge.

- a) **Picture and model.** Assume your hand oscillates sinusoidally up and down with some frequency and some amplitude. The broom is instantaneously at some angle from vertical. Draw a picture which defines all the variables you will use. Use any mass distribution that you like.
- b) **FBD.** Draw a FBD of the broom.
- c) **Momentum balance.** Write the equation of angular momentum balance about the point instantaneously coinciding with the hinge.
- d) **Kinematics.** Use any geometry and kinematics that you need to evaluate the terms in the angular momentum balance equation in terms of the tip angle and its time derivatives and other known quantities (take the vertical motion of your hand as 'given'). [Hint: There are many approaches to this problem.]
- e) **Equation of motion.** Using the angular momentum balance equation, write a governing differential equation for the tip angle. *
- f) **Simulation.** Taking the hand motion as given, simulate on the computer the system you have found.
- g) **Stability?** Can you find an amplitude and frequency of shaking so that the broom stays upright if started from a near upright position? You probably *cannot* find linear equations to solve that will give you a control strategy. So, this problem might best be solved by guessing on the computer. Successful strategies require the hand acceleration to be quite a bit bigger than g , the gravitational constant. The stability obtained is like the stability of an undamped uninverted pendulum — oscillations persist. You improve the stability a little by including a little friction in the hinge.

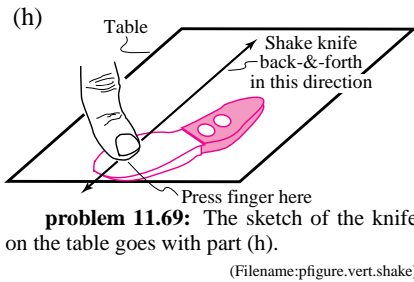
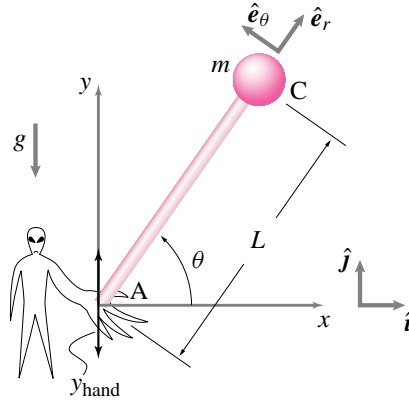

- a) Given the tip angle ϕ , the tip rate $\dot{\phi}$ and the values of the various parameters (m, R, L, g) find $\ddot{\phi}$. [You may assume ϕ and $\dot{\phi}$ are small.] *
- b) Using the result of (a) or any other clear reasoning find the conditions on the parameters (m, R, L, g) that make vertical passive dynamic standing stable. [Stable means that if the person is slightly perturbed from vertically up that their resulting motion will be such that they remain nearly vertically up for all future time.] answer below is questionable, says someone *

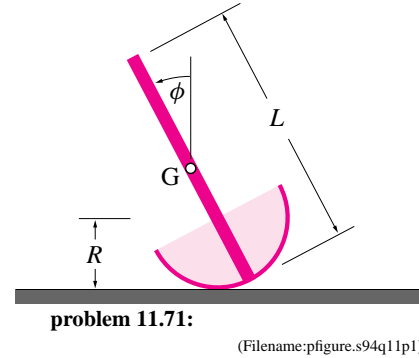

- h) **Dinner table experiment for nerdy eaters.** If you put a table knife on a table and put your finger down on the tip of the blade, you can see that this experiment might work. Rapidly shake your hand back and forth, keeping the knife from sliding out from your finger but with the knife sliding rapidly on the table. Note that the knife aligns with the direction of shaking (use scratch-resistant surface). The knife is different from the broom in some important ways: there is no gravity trying to 'unalign' it and there is friction between the knife and table that is much more significant than the broom interaction with the air. Nonetheless, the experiment should convince you of the plausibility of the balancing mechanism. Because of the large accelerations required, you *cannot* do this experiment with a broom.

11.5 Dynamics of rigid bodies in multi-degree-of-freedom 2D mechanisms

11.70 Double pendulum. The double pendulum shown is made up of two uniform bars, each of length ℓ and mass m . The pendulum is released from rest at $\phi_1 = 0$ and $\phi_2 = \pi/2$. Just after release what are the values of $\ddot{\phi}_1$ and $\ddot{\phi}_2$? Answer in terms of other quantities. *

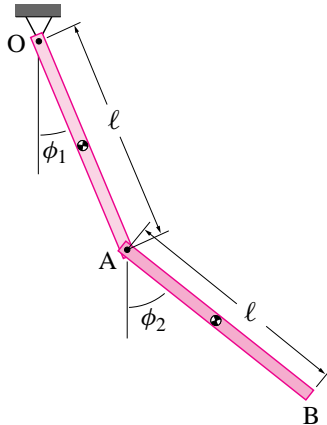

11.71 A rocker. A standing dummy is modeled as having massless rigid circular feet of radius R rigidly attached to their uniform rigid body of length L and mass m . The feet do not slip on the floor.

11.6 Advanced dynamics of planar motion

11.72 Consider a rigid spoked wheel with no rim. Assume that when it rolls a spoke hits the ground and doesn't bounce. The body just swings around the contact point until the next spoke hits the ground. The uniform spokes have length R . Assume that the mass of the wheel is m , and that the polar moment of inertia about its center is I (use $I = mR^2/2$ if you want to get a better sense of the solution). Assume that just before collision number n , the angular velocity of the wheel is ω_{n-} , the kinetic energy is T_{n-} , the potential energy (you must clearly define your datum) is U_{n-} . Just after collision n the angular velocity of the wheel is ω_{n+} . The Kinetic Energy is T_{n+} , the potential energy (you must clearly define your datum) is U_{n+} . The wheel has k spokes (pick $k = 4$ if you have trouble with abstraction). This problem is not easy. It can be answered at a variety of levels. The deeper you get into it the more you will learn.

- a) What is the relation between ω_{n-} and T_{n-} ?
- b) What is the relation between ω_{n-} and ω_{n+} ?
- c) Assume 'rolling' on level ground. What is the relation between ω_{n+} and ω_{n+1} ?
- d) Assume rolling down hill at slope θ . What is the relation between ω_{n+} and ω_{n+1} ?

- e) Can it be true that $\omega_{n+} = \omega_{(n+1)+}$?
About how fast is the wheel going in this situation?
- f) As the number of spokes m goes to infinity, in what senses does this wheel become like an ordinary wheel?

k evenly spaced spokes

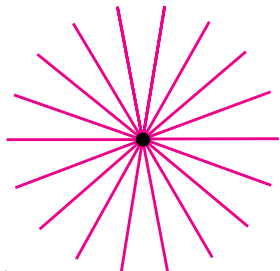

problem 11.72:

(Filename:pfigure.blue.109.1)

Problems for Chapter 12

General motion in 3-D

12.1 Orientation in 3-D

12.1 Find a rotation from a picture.

12.2 Velocity and acceleration of points on a rigid body: $\vec{\omega}$ and $\vec{\alpha}$

12.2 A particle moves on a helix. Say you know that a particle moves according to the equation

$$\mathbf{r} = R \cos \theta \hat{i} + R \sin \theta \hat{j} + z \hat{k}$$

where R is a constant, $\theta = c_1 t$, and $z = c_2 t$.

- Find \vec{v} at general time t .
- Find \vec{a} at general time t .
- Find \hat{e}_t at general time t .
- Find \hat{e}_n at general time t .
- Write \vec{a} in terms of \hat{e}_t and \hat{e}_n .
- What is the radius of the osculating circle? Check your answer to see if it makes sense in the special case when $c_2 = 0$.

12.3 A curious chef tosses a potato in the air. Being a part-time dynamicist, she has just the right instruments in her kitchen and measures the absolute angular velocity of the potato to be $\vec{\omega} = 1\hat{i} + 2\hat{j} + 3\hat{k}$ (rad/s) and the absolute center of mass velocity to be $\vec{v}_G = 3\hat{i} + 4\hat{j} + 5\hat{k}$ (in/s), at a particular instant in time. At the same instant in time, she notes the position of an eye on the potato relative to its center of mass, point G , is $\vec{r}_{E/G} = 1\text{ in}\hat{i}$. (The high quality potato came from the market with the center of mass already marked inside it.) \hat{i}, \hat{j} , and \hat{k} are basis vectors in the kitchen frame.

- What is the velocity of the potato eye relative to G , $\vec{v}_{E/G}$?
- What is the absolute velocity of the potato eye, \vec{v}_E ?

12.3 Instantaneous dynamics and “inverse dynamics” in 3-D

12.4 Under what circumstances is the linear momentum of a system conserved (that is, does not change with time)?

12.5 For a continuous system, where at a given instant in time velocity depends on position, $\vec{v} = \vec{v}(\vec{x})$, (a) how is linear momentum defined? (b) How is rate of change of linear momentum defined?

12.6 For what points C , with positions \vec{r}_C , are the balance of angular momentum equations $\sum \vec{M}_C = \dot{\vec{H}}_C$, correct:

- the origin,
- the center of mass, and
- any point anywhere?

12.7 Bead on a stationary 3-D wire. A bead with mass m slides on a frictionless wire that is fixed in space. The wire is twisted and curved in complicated ways. There is no gravity. The only force on the bead comes from the wire. The initial speed of the bead is v_0 . Justify your answers to the following questions with text and/or equations. Add any extra assumptions if you feel they are required.

- Is it true that $\vec{F} = m\vec{a}$ (where \vec{F} is the total force on the bead and \vec{a} its acceleration)?
- Is the momentum of the bead, $m\vec{v}$, constant?
- Is the kinetic energy of the bead, $\frac{1}{2}mv^2$, constant?
- What is the speed of the bead at $t = 3$ s?
- Is the acceleration always such that $\vec{a} \cdot \hat{e}_t = 0$ (where \hat{e}_t is the unit tangent to the wire)?
- Is the acceleration always such that $\vec{a} \cdot \hat{e}_n = 0$ (where \hat{e}_n is the unit normal to the wire)?
- Using any notation you like to describe the wire shape, write an expression for the force \vec{F} on the bead from the wire.
- For a circular wire, what is the direction of the force from the bead on the wire?
- For a helical wire, (say, $\vec{r} = r_0 \cos \theta \hat{i} + r_0 \sin \theta \hat{j} + C\theta \hat{k}$), what is the direction of the force from the bead on the wire? *

12.8 A 500 kg roller coaster car travels along a track defined by the conical spiral $r = z$, $\theta = -2z$. If $\dot{\theta} = 2$ rad/s is constant, determine the force exerted on the car by the track when $z = 5$ m. Assume that the gravitational force acts in the negative z direction. Remember to express the force in vector form.

12.9 When do you use which term in $\dot{\vec{H}}_O$ formula for a rigid body? To do the angular momentum balance about an arbitrary point O we write $\sum \vec{M}_O = \dot{\vec{H}}_O$ where the most general formula for $\dot{\vec{H}}_O$ for one rigid body is

$$\dot{\vec{H}}_O = \vec{r}_{cm/O} \times m\vec{a}_{cm} + [\mathbf{I}^{cm}] \cdot \dot{\vec{\omega}} + \vec{\omega} \times ([\mathbf{I}^{cm}] \cdot \vec{\omega}).$$

Give examples of motions of a rigid body (you may also use a point mass) in which

- only one term at a time in the above formula for $\dot{\vec{H}}_O$ survives (three examples) and
- only two terms at a time in the formula survive (three examples).

12.10 (See also problems 12.33, 12.35, and 12.38.) Find the reaction supplied by the environment to the system of bodies $\mathcal{A}\mathcal{B}\mathcal{D}$ so that each body spins at a constant rate in problem 12.27. *

12.11 Disk suspended at corner by a ball and socket joint. See also problem 12.13. A disk with negligible mass has two point masses glued to it. It is stationary and horizontal when it is allowed to fall, but it is held back by a ball-and-socket joint at one point on its perimeter. Just after the disk is released, what is the acceleration of the point P? Is it up or down? *

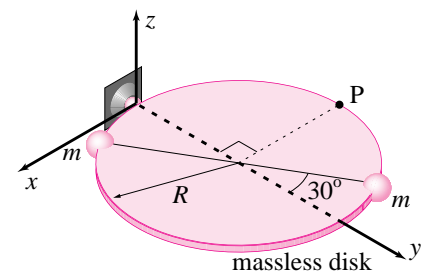

problem 12.11:

(Filename: pfigure.s94h13p2)

12.12 A car driving in circles counter-clockwise at constant speed so that its left rear tire has speed v_0 (the middle of the tire, that is, or the location of the ground contact point.) The radius of the circle that the tire travels on is R_0 . The radius of the tire is r_0 . Right next to the tire is the car fender (i.e., the fender overlaps the outer face of the tire. In fact the fender is rubbing on the tire just a little, but not quite enough to disturb any insects that might be in the neighborhood).

- a) What is the angular velocity of the car? *
- b) What is the angular velocity of the tire relative to the car? *
- c) What is the angular velocity of the tire? *
- d) What is the total torque applied to the car (not including the tires as part of the car, the rotating engine is also massless) relative to the car center of mass? *
- e) What is the total torque on the car relative to the center of the circle around which it is traveling? *
- f) What is the angular momentum of the tire relative to its center of mass (use any sensible model of the tire, say a rigid disk.)? *
- g) What is the rate of change of angular momentum of the tire (relative to its center of mass)? *
- h) What is the total torque of all the forces applied to the tire from the road and the car as calculated at the center of the tire? *
- i) A bug is climbing straight up on the car fender named at speed v_g . At the instant of interest she is right next to the center of the wheel. What is her velocity and acceleration? What is the total force acting on her? *
- j) Another bug is climbing on a straight line marked on the tire at constant speed v_b . He is in the middle of the tire at the instant of interest. What is his absolute velocity and acceleration? What is the total force acting on him? (Both bugs are at the same place at the instant of interest and walking on lines that are, at the moment, parallel.)
- k) Redo the problem, questions (a)-(j), but this time the car speed is increasing with acceleration a_o . Questions (a) - (j) of this problem are a special case of question (k). You should check that your answers from (k) reduce to the answers in questions (a) - (j). Or, if you are really cocky, you should skip the first questions and only do (k). Then, display your answers for the special case $a_o = 0$.

12.13 The moment of inertia matrix. Reconsider the system of problem 12.11 — a disk with negligible mass that has two point masses glued to it.

- a) Find the moment of inertia matrix $[I^O]$ of the system.
- b) Find the angular acceleration of the system when released from rest in the configuration shown. You may use your answer from problem 12.11.

12.14 A square plate in space. A uniform square plate with mass m and sides with length $2L$ is floating stationary in space. A force of magnitude F is suddenly applied to it at point A. Using the coordinates shown the moment of inertia matrix for this plate is:

$$[I_{/cm}] = \frac{mL^2}{3} \begin{bmatrix} 1 & 0 & 0 \\ 0 & 1 & 0 \\ 0 & 0 & 2 \end{bmatrix}$$

- a) What is the acceleration of the center of the plate \vec{a}_G ? *
- b) What is the angular acceleration of the plate $\vec{\omega}$? *
- c) What is the acceleration of point B \vec{a}_B ? *

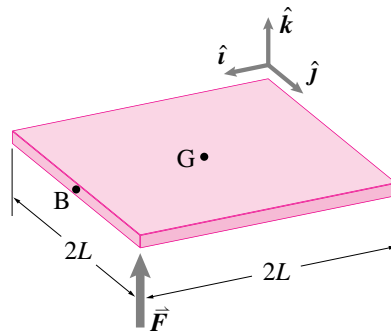

problem 12.14:

(Filename:pfigure.t93f5)

12.15 Force on a rectangular plate in space. A uniform rectangular plate of mass $m = 10 \text{ lbf}$ is floating in space. A force $F = 5 \text{ lbf}$ is suddenly applied at a corner that is perpendicular to the plate.

- a) Find the acceleration of the center of mass of the plate. * $\vec{a} = -16 \text{ ft/s}^2 \hat{k}$
- b) Find the angular acceleration of the plate. *
- c) Some of the plate accelerates in the direction of the force and some accelerates back towards the tail of the force vector. What part of the plate accelerates in the opposite direction of the applied force?

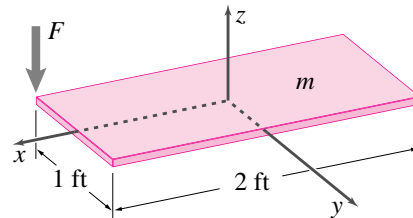

problem 12.15:

(Filename:pfigure.s94h13p3)

12.16 Force on a square plate. A constant force with magnitude F is applied, in the direction shown in the yz plane, to the corner B of a uniform square plate with side length d and mass m . Before the force is applied the plate is at rest in space with no other forces applied to it. Consider the time immediately after the time of the force application.

- a) What, in terms of $m, F, d, \hat{i}, \hat{j}, \hat{k}$, and ϕ is the acceleration of point B ?
- b) For what angle ϕ is the acceleration of point B in the direction of the force?
- c) Find another direction for F so that the force at B and the acceleration at B are parallel (not necessarily in the $\hat{j}-\hat{k}$ plane). [Physical reasoning will probably work more easily than mathematical reasoning.]
- d) Find yet another direction for F so that the force at B and the acceleration at B are parallel (not necessarily in the $\hat{j}-\hat{k}$ plane).

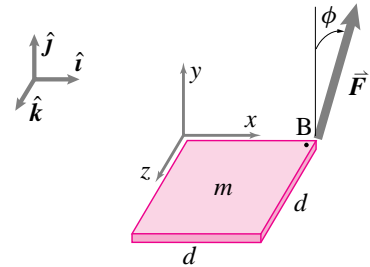

problem 12.16:

(Filename:p.s96.p3.3)

12.17 (See also problems 12.32, 12.34, and 12.37.) Find the reaction supplied by the environment to the system of bodies $\mathcal{A}\mathcal{B}\mathcal{D}$ so that each body spins at a constant rate in problem 12.31.

12.4 Time evolving dynamics of an unconstrained rigid body in 3-dimensions

12.18 A rigid body flies through the air and tumbles. Find the equations of motion and solve them for your choice of parameters and initial conditions.

12.5 Kinematics of motion relative to a moving and rotating reference frame in 3-D

12.19 Find the rotation matrix $[\mathbf{R}]$ for $\theta = 30^\circ$ such that $\{\hat{e}'\} = [\mathbf{R}]\{\hat{e}\}$, where $\hat{e} = \{\hat{i}, \hat{j}, \hat{k}\}$. Using the rotation matrix, find the components of $\vec{v} = 2 \text{ m/s} \hat{i} - 3 \text{ m/s} \hat{j} + 1 \text{ m/s} \hat{k}$ in the rotated coordinate system.

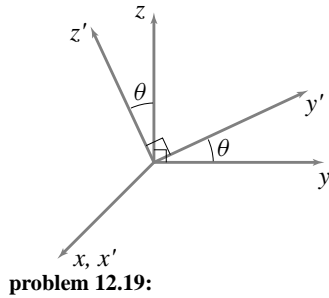

(Filename:efig1.2.28)

12.19 A circular plate rotates at a constant angular velocity $\vec{\omega} = 5 \text{ rad/s} \hat{k}$. A set of coordinate axes $x'y'z'$ is glued to the plate at its center and thus rotates with $\vec{\omega}$. Find the rate of change basis vectors \hat{i}' , \hat{j}' , and \hat{k}' using the $\dot{\mathbf{Q}}$ formula.

12.21 A rigid body \mathcal{B} rotates in space with angular velocity $\vec{\omega} = (2\hat{i} + 3\hat{j} - \hat{k}) \text{ rad/s}$. A set of local coordinate axes $x'y'z'$ is fixed to the body at its center of mass. The position vector \vec{r}_P of a point P is given in local coordinates: $\vec{r}_P = (5\hat{i}' + \hat{j}') \text{ m}$. Find the velocity (\vec{v}_P) of point P using the $\dot{\mathbf{Q}}$ formula.

12.22 The rotation matrix between two coordinate systems with basis vectors $(\hat{e}_1, \hat{e}_2, \hat{e}_3)$ and $(\hat{E}_1, \hat{E}_2, \hat{E}_3)$ is \mathbf{Q} such that $\{\hat{e}\} = [\mathbf{Q}]\{\hat{E}\}$. Find the components of $\vec{a} = (-2\hat{e}_1 + 3\hat{e}_3) \text{ m/s}^2$ in the $(\hat{E}_1, \hat{E}_2, \hat{E}_3)$ basis if $\vec{Q} = \begin{bmatrix} 1 & 0 & 0 \\ 0 & \frac{1}{2} & -\frac{\sqrt{3}}{2} \\ 0 & \frac{\sqrt{3}}{2} & \frac{1}{2} \end{bmatrix}$.

12.23 Let \mathcal{B} and \mathcal{F} be two moving rigid bodies. Show that $\vec{\omega}_{\mathcal{B}/\mathcal{F}} = \vec{\omega}_{\mathcal{B}} + \vec{\omega}_{\mathcal{F}}$.

12.24 George is driving his car on the highway on a rainy day. His windshield wipers are on. He notices that a drop of water on the wiper blade is moving along the blade at approximately 3 in/s. Although the wipers rotate at variable angular speed, he approximates that when the wiper is parallel to his nose, its angular speed is $\pi/2 \text{ rad/s}$. In George's coordinate system (attached to his frame of reference and moving with him), the wiper is rotating in the positive \hat{j} direction and the water-drop is moving in the positive \hat{k} direction at the moment of interest. Find the velocity of the water-drop in George's frame of reference.

12.25 A person sits on a bar stool which spins at angular speed Ω . Simultaneously, (s)he hoists a beer glass of mass m up at angular speed ω relative to the bar stool with a straight, rigid arm of length L . θ measures the angle of her/his arm with respect to the XY plane. XYZ is an inertial coordinate system; YZ lies in the plane of the paper. If you use moving axes to do this problem, specify clearly his/her orientation and motion.

- What is the angular velocity of the person's arm?
- What is the angular acceleration of the person's arm?
- What is the linear velocity of the beer glass relative to inertial space?
- What is the linear acceleration of the beer glass relative to inertial space?
- Describe how you would point an absolutely full glass such that the beer will not spill out.

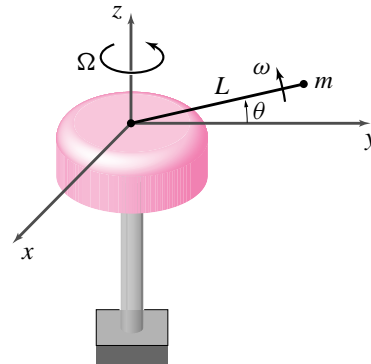

problem 12.25: (Filename:pfimage.blue.118.2)

12.26 Kinematics of a disk spinning on a spinning rod. The rigid rod \mathcal{R} rotates at constant rate Ω about the z axis. Attached to this rod, a distance R from the origin, is the center C of a disk \mathcal{C} with diameter D . The disk is rotating at constant rate ω about an axis y' that is attached to, and rotates with, the rod. A point B is on the outer edge of the disk. At the moment of interest, the system is in the configuration shown with $\vec{r}_{CB} = (D/2)\hat{k}$.

- What is the absolute angular velocity of the disk, $\vec{\omega}_{\mathcal{D}}?$ *
- What is the absolute angular acceleration of the disk $\vec{\alpha}_{\mathcal{D}}?$ *
- What is the absolute velocity of point B, $\vec{v}_B?$ *
- What is the absolute acceleration of point B, $\vec{a}_B?$ *

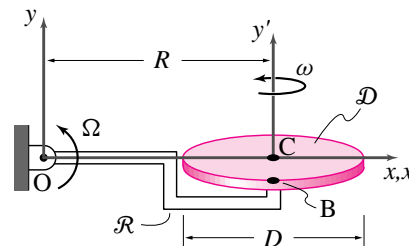

problem 12.26: (Filename:pfimage.s95f3a)

12.27 See also problems 12.33, 12.35, and 12.38. Body \mathcal{A} rotates with respect to a Newtonian frame \mathcal{F} at a constant angular rate ω_0 about axis OO' . Body \mathcal{B} , a 'fork', rotates with respect to body \mathcal{A} at a constant angular rate ω_1 about axis PP' . Bodies \mathcal{A} and \mathcal{B} are

of negligible mass. Body \mathcal{D} , a uniform disc of mass m , rotates with respect to body \mathcal{B} , at a constant angular rate ω_2 about axis CC' . Each of the bodies is turned at constant rate by motors(not shown.) At the instant shown, find the absolute angular velocity of body \mathcal{D} , $\vec{\omega}_{\mathcal{D}/\mathcal{F}}$. *

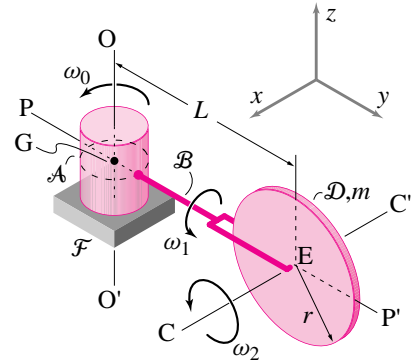

problem 12.27: (Filename:Dane94s1q2)

12.28 A particle P of mass m is attached to the edge of the disk of radius R , as shown in the figure. The disk spins about its center line with constant angular speed $\omega \text{ rad/s}$ relative to the shaft OB . The shaft OB rotates with angular speed $\Omega \text{ rad/s}$. For the instant when the disk lies in the YZ plane, and the particle is on the Y axis, as shown:

- Find the particle's velocity relative to XYZ .
- Calculate the particle's acceleration relative to XYZ .
- Calculate the force \vec{F} acting on the particle.

If you choose to use another coordinate system, define it explicitly.

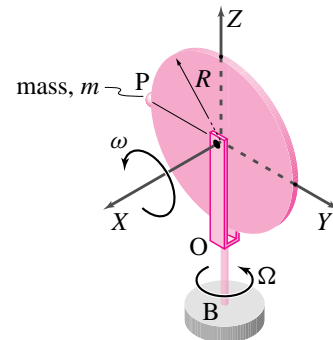

xyz : fixed frame
problem 12.28: (Filename:pfimage.blue.123.1)

12.29 See also problem 12.53. Two identical thin disks, bodies \mathcal{C} and \mathcal{D} , of radius r are connected (perpendicularly) to opposite ends of a thin axle, as depicted below. The axle rotates about the fixed Z axis at a constant angular speed Ω , and the disks roll without slipping. Determine:

- The total angular velocity of each disk, $\vec{\omega}_{\mathcal{C}}$ and $\vec{\omega}_{\mathcal{D}}$, and

(b) The total angular acceleration of each disk, α_C and α_D .

(Express your answers relative to the rotating basis $\{\hat{i}, \hat{j}, \hat{k}\}$.)

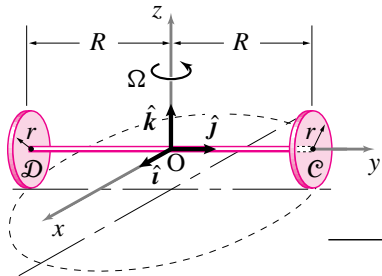

problem 12.29:

(Filename:pfigure.blue.119.2)

12.30 Kinematics of a rolling cone. See also problem 8.19. A solid cone with circular-base radius r and height h moves as follows. Point O is fixed in space. The cone surface always contacts the plane but may roll and/or slide. The axis of the cone OB rotates about the vertical axis with constant angular velocity $-\omega_1 \hat{i}$. The cone spins about this moving axis \hat{j}' with constant angular rate ω_2 .

- At the instant shown what is the velocity of point B ? (in terms of some or all of $\omega_1, \omega_2, r, h, \hat{i}, \hat{j}$, and \hat{k})*
- At the instant shown what is the angular acceleration of the cone? (in terms of some or all of $\omega_1, \omega_2, r, h, \hat{i}, \hat{j}$, and \hat{k})*
- If the disk rolls with no slip, find ω_1 in terms of ω_2, r and h .*
- If the disk rolls with no slip and point B has constant speed v find the magnitude of the angular acceleration of the cone in terms of v, r and h .*

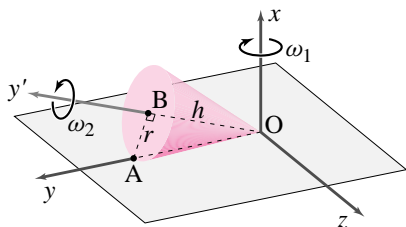

problem 12.30: Cone rolling on a plane

(Filename:pfigure.s95q14)

12.31 See also problems 12.32, 12.34, 12.37, and 12.17. Body \mathcal{A} rotates with respect to a Newtonian frame \mathcal{F} at a constant angular rate ω_0 about axis OO' . Body \mathcal{B} , a 'fork', rotates with respect to body \mathcal{A} at a constant angular rate ω_1 about axis PP' . Bodies \mathcal{A} and \mathcal{B} are of negligible mass. Body \mathcal{D} , a uniform disc of mass m , rotates with respect to body \mathcal{B} , at a constant angular rate ω_2 about axis CC' . Each of the bodies is turned at constant rate by motors(not shown.) At the instant shown, find the absolute velocity and acceleration of point Q on the disk.

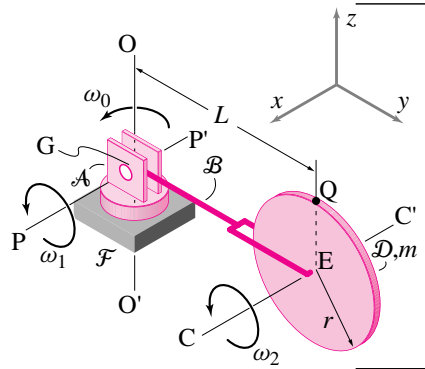

problem 12.31:

(Filename:Danf94s3q2)

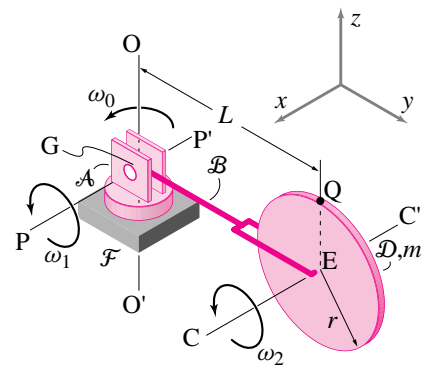

problem 12.34:

(Filename:bikefork1.alt)

12.32 (See also problems 12.34, 12.37, and 12.17.) For the system in problem 12.31, find the absolute angular acceleration of frame \mathcal{D} , $\alpha_{\mathcal{D}}$, at the instant shown.

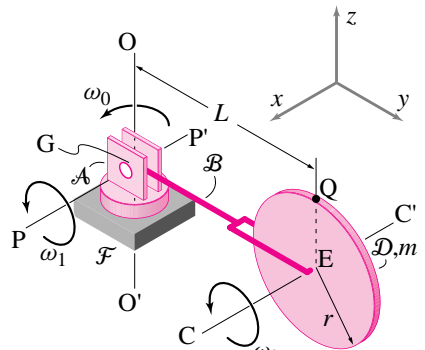

problem 12.32:

(Filename:bikefork1.ang.accel)

12.35 (See also problems 12.33, 12.38, and 12.10.) For the configuration in problem 12.27, find the velocity and acceleration of the point on the edge of the disk directly above its center point E using the alternative method.

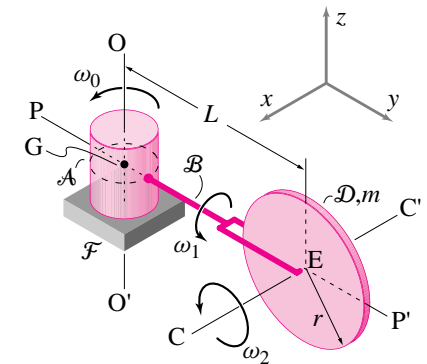

problem 12.35:

(Filename:bikefork.alt)

12.33 (See also problems 12.35, 12.38, and 12.10.) For the system in problem 12.27, find the absolute angular acceleration of frame \mathcal{D} , $\alpha_{\mathcal{D}}$, at the instant shown.*

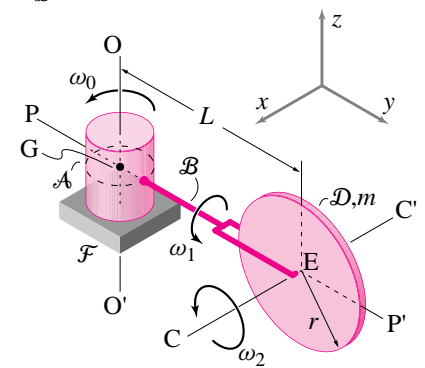

problem 12.33:

(Filename:bikefork.ang.accel)

12.34 (See also problems 12.32, 12.37, and 12.17.) For the configuration in problem 12.31, find the velocity and acceleration of point Q on the disk using the alternative method.

12.36 To simulate the flight conditions of a space vehicle, engineers have developed the centrifuge, shown diagrammatically in the figure. A main truss arm of length $\ell = 15$ m, rotates about the AA axis. The pilot sits in the capsule which may rotate about axis CC. The seat for the pilot may rotate inside the capsule about an axis perpendicular to the page and going through the point B. These rotations are controlled by a computer that is set to simulate certain maneuvers corresponding to the entry and exit from the earth's atmosphere, malfunctions of the control system, etc. When a pilot sits in the capsule, his head, particularly his ears, has the position shown in the enlarged figure, a distance $r = 1$ m from point B.

The main arm is rotating at $\Omega = 10$ rpm and accelerating at $\dot{\Omega} = 5$ rev/min², the capsule is rotating at a constant speed about CC at $\omega_c = 10$ rpm, and the seat rotates at a speed of $\omega_s = 5$ rpm inside the capsule.

- Determine the acceleration, in terms of how many g 's, that the pilot's head is subjected to by choosing a moving coordinates system xyz centered at B and fixed to the capsule.
- Repeat the calculations of (A) by letting xyz be fixed to the seat.*

- c) Choose another moving coordinates system to solve the same problem.
- d) A pilot has different tolerances for acceleration components. They are roughly:
 - (a) In a vertical direction, i.e., toe to head $-5\text{ g}'\text{s}$. (Here the pilot experiences blackout or may pass out completely.)
 - (b) Front to rear $-1.5\text{ g}'\text{s}$. (Here vision becomes greatly distorted.)

Arrange a test program on the centrifuge so that each acceleration is reached separately while the other accelerations are kept below one-half their tolerance levels.

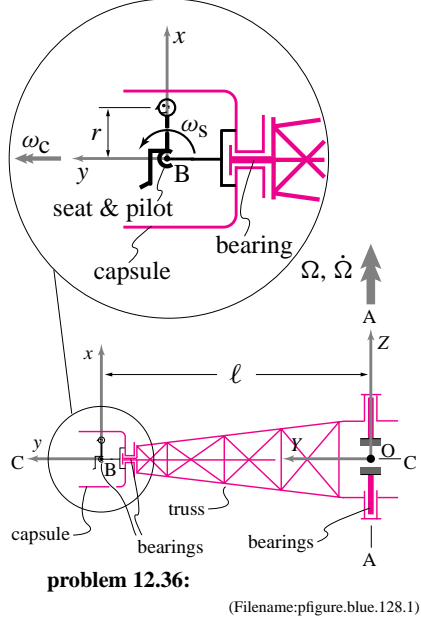

12.6 Mechanisms in 3-D

12.37 (See also problems 12.32, 12.34, and 12.17.) Reconsider the system in problem 12.31. Bodies \mathcal{A} and \mathcal{B} are of negligible mass and body \mathcal{D} is a uniform disc of mass m . Find the angular momentum and rate of change of angular momentum of the system of bodies $\mathcal{A}\mathcal{B}\mathcal{D}$ about:

- a) point G
- b) point E .

Make reasonable assumptions about moments of inertia.

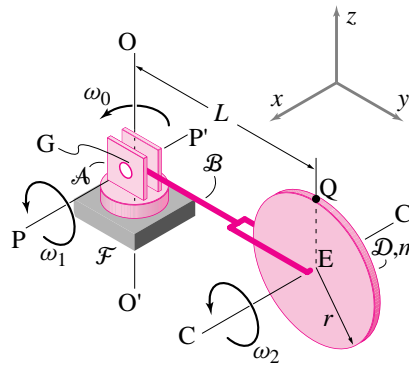

12.38 (See also problems 12.33, 12.35, and 12.10.) Reconsider the system in problem 12.27. Bodies \mathcal{A} and \mathcal{B} are of negligible mass and body \mathcal{D} is a uniform disc of mass m . Find the angular momentum and rate of change of angular momentum of the system of bodies $\mathcal{A}\mathcal{B}\mathcal{D}$ about:

- a) point G *
- b) point E .*

Make reasonable assumptions about moments of inertia.

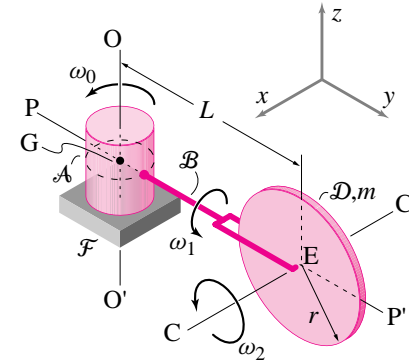

12.39 Reconsider problem 12.48. A thin uniform disk \mathcal{D} of mass $m = 2\text{ kg}$ and radius $r = 0.2\text{ m}$ is mounted on a massless shaft AB as shown in the figure. Rod CO is welded to the shaft and has negligible mass. The shaft rotates at a constant angular speed $\Omega = 120\text{ rpm}$ about the positive x -axis. The disk spins about its own axis at a constant rate $\omega = 60\text{ rpm}$ with respect to the shaft (or bar CO). Find the dynamic reactions on the bearings at A and B at the instant shown. *

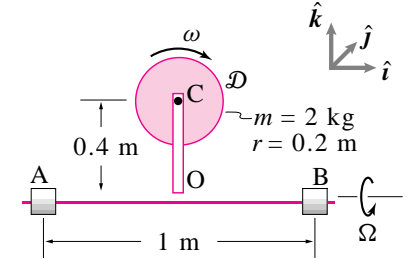

12.40 A bead P rides on a frictionless thin circular hoop of radius R . The hoop rotates about its diameter at a constant angular speed ω in the vertical plane. Find, in terms of θ , $\dot{\theta}$ and ω and base vectors you define (a) the velocity of the bead (a vector) and (b) the acceleration of the bead (a vector).

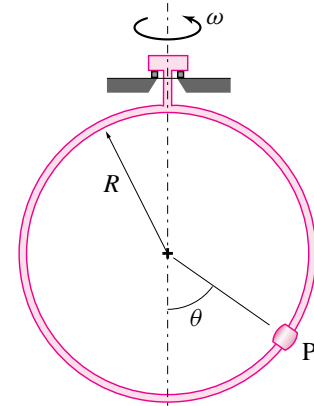

12.41 A thin rod of mass m and length L moves while making contact with the frictionless surface (the $\hat{e}_1 - \hat{e}_2$ plane) at its tip A , as shown in the figure. θ is assumed to be constant and the rod always remains in the \hat{e}_3, \hat{e}_r plane.

- a) What is the kinematical relation between the velocity of the center of mass, \vec{v}_G , and the angular velocity of the rod, $\vec{\omega}$?
- b) Obtain the equations of motion of the rod in terms of the speed of point A and the angle ϕ .

The unit vectors \hat{e}_1^* and \hat{e}_3^* lie in the $(\hat{e}_3 - \hat{e}_r)$ plane and \hat{e}_2^* is normal to the $(\hat{e}_3 - \hat{e}_r)$ plane. The starred basis vectors are written in terms of the the standard basis as follows:

$$\begin{aligned} \hat{e}_r &= \cos\theta\hat{e}_1 + \sin\theta\hat{e}_2, \\ \hat{e}_1^* &= \sin\phi\hat{e}_3 + \cos\phi\hat{e}_r, \\ \hat{e}_3^* &= \cos\phi\hat{e}_3 + \sin\phi\hat{e}_r, \quad \text{and} \\ \hat{e}_2^* &= -\sin\theta\hat{e}_1 + \cos\theta\hat{e}_1. \end{aligned}$$

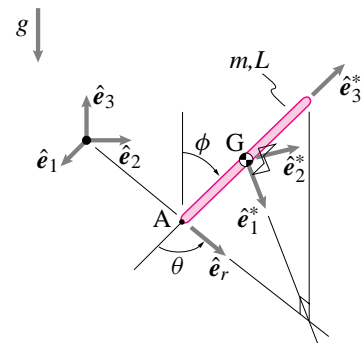

12.42 A cosmonaut who is otherwise free to move in 3-dimensional space finds himself stuck to the surface of a giant stationary cylinder with slippery magnets. There is no friction and (net) gravity is negligible. θ and z are cylindrical coordinates that are aligned with the cylinder and mark the position of the cosmonaut relative to the cylinder. The cylinder has radius a . A nearby astronaut notes that at time $t = 0$: $\theta = \theta_0$, $\dot{\theta} = \dot{\theta}_0$, $z = z_0$, and $\dot{z} = \dot{z}_0$. What does she predict for the location of the cosmonaut (the values of θ and z) at an arbitrary later time t ? You can assume that both the cylinder and the astronaut were stationary in the same Newtonian (inertial) frame.

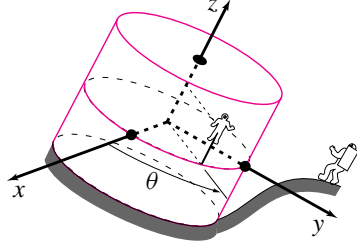

problem 12.42:

(Filename:pfigure.blue.68.1)

12.43 You are an astronaut in free space and your jet pack is no longer operating. You wish to reorient your body in order to face the central government buildings so as to salute your national leaders before reentering the atmosphere. Discuss whether this maneuver can be done in terms of momentum, energy, or other dynamical concepts. (You are free to move your arms and legs, but you are not allowed to throw anything.) [For aliens and those less patriotic, the same problem arises in the case of a trampoline jumper who decides to change direction in mid-air. Is it possible?]

12.44 A collar slides on the rigid rod ABC that has a 30° bend at B as shown in the figure. The collar is currently at point D on the rod. The rod ABC is held by fixed hinges that are aligned with the z -axis, and rotates at the constant rate $\omega_1 = 2 \text{ rad/s}$. The collar has mass $m_D = 1 \text{ kg}$.

- Assume a mechanism not shown constrains the collar to slide out along the rod at the constant rate $u = 1 \text{ m/s}$ (u is the distance along the rod traveled per unit time). What is the net force that acts on the collar when it is 1 m from B ?
- Assume that the contact between the collar and the rod is frictionless and that no forces act on the collar besides those due to the rod (e.g. neglect gravity). At the instant shown in the picture, assume that $u = 1 \text{ m/s}$ (because of some initial conditions not discussed here) but is not necessarily constant in time. What is the acceleration of the collar?

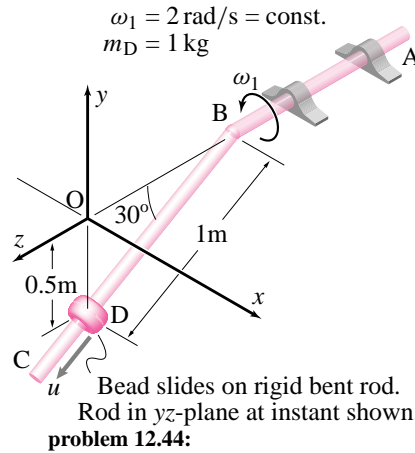

problem 12.44:

(Filename:pfigure.blue.58.1)

12.45 A bifilar pendulum is formed of a rod of length a and mass m , supported by two filaments of length ℓ and separation $2b$. What is the frequency of small "torsional" oscillations about a vertical axis through the rod's mid-point O ?

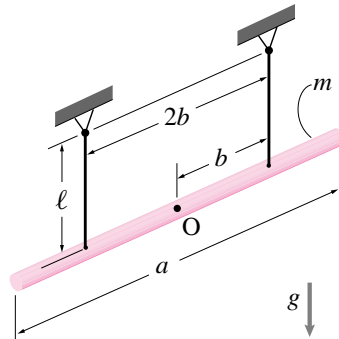

problem 12.45:

(Filename:pfigure.blue.157.1)

12.46 A trifilar pendulum is formed of a thin horizontal disk of radius a and mass m , hung by three wires a distance ℓ below the ceiling. The wire attachments are equally spaced on the perimeter of the disk. The attachment points on the ceiling form an equilateral triangle.

- If the support wires are vertical what is the period of oscillation?
- How big should the triangle on the ceiling be to minimize the period of oscillation?
- To maximize the period of oscillation?

12.7 Circles on circles and other special 3-D motions

12.47 Sometimes thrown footballs (and frisbees too!) wobble and sometimes they spin smoothly. Describe as best you can why these motions differ.

12.48 See also problem 12.39. A thin uniform disk \mathcal{D} of mass $m = 2 \text{ kg}$ and radius $r = 0.2 \text{ m}$

is mounted on a massless shaft AB as shown in the figure. Rod CO is welded to the shaft and has negligible mass. The shaft rotates at a constant angular speed $\Omega = 120 \text{ rpm}$ about the positive x -axis. The disk spins about its own axis at a constant rate $\omega = 60 \text{ rpm}$ with respect to the shaft (or bar CO). Find the absolute angular velocity and acceleration of the disk. *

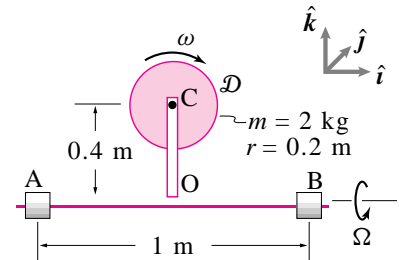

problem 12.48:

(Filename:summer95f.5)

12.49 A thin circular disk of mass m and radius R is mounted on a thin light axle, coincident with its axis of symmetry. The axle is supported by bearings A and B attached to a turntable, as shown in the figure. The turntable spins at a constant speed Ω about \hat{e}_3 , while the disk spins about its axle at a constant speed μ relative to the turntable (via motors not shown). The radial unit vector $\hat{e}_r = \cos(\Omega t)\hat{e}_1 + \sin(\Omega t)\hat{e}_2$ is fixed to the turntable and aligned with \hat{e}_1 at time $t = 0$. Compute the vertical components of the reaction forces at A and B . Will the reaction forces change with time?

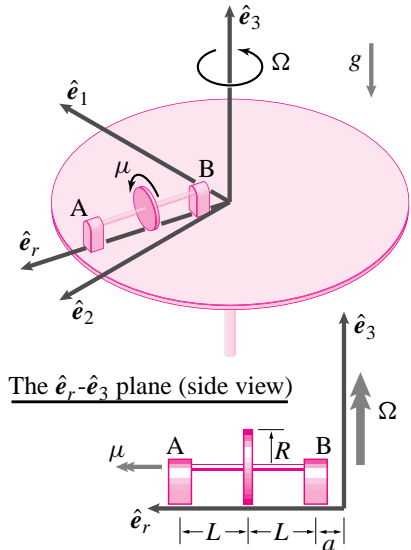

problem 12.49:

(Filename:pfigure.blue.127.2)

12.50 Steady precession of a spinning disk. A uniform disk of mass $m = 2 \text{ kg}$ and radius $R = 0.25 \text{ m}$ is rigidly mounted on a massless axle AB which is supported by frictionless bearings at A and B . The axle, in turn, is mounted on a massless semi-circular gimbal as shown in the figure. The gimbal rotates about the vertical x -axis, which passes through the center of the disk D , at a constant rate $\Omega = 2 \text{ rad/s}$. The

axle AB is spinning at a constant rate $\omega = 120$ rpm with respect to the gimbal. At the instant shown, the axle is aligned with the z -axis and the disk D is in the xy -plane. Ignore gravity. At the instant of interest:

- What is the angular velocity $\vec{\omega}_D$ of the disk? *
- What is the angular acceleration of the disk? *
- What is the net torque required to keep the motion going? *
- What are the reaction forces at the bearings A and B? *

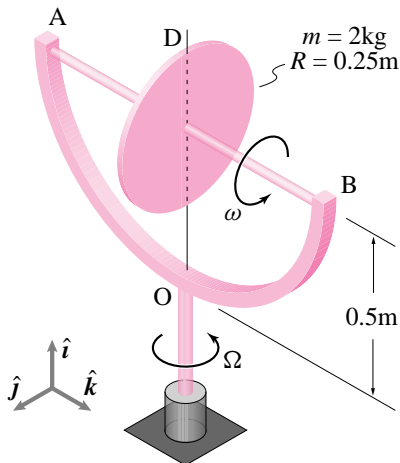

problem 12.50:

(Filename:pfigure.s94h13p4)

12.51 A cyclist rides a flat, circular track of radius $r = 150$ ft at a constant tangential speed of $v = 22$ ft/s on 27 in diameter wheels. Assuming that the bicycle is vertical, determine the total angular velocity and angular acceleration of the wheel of the bike in the sketch (the rest of the bicycle is not shown). Use the coordinates given in the sketch.

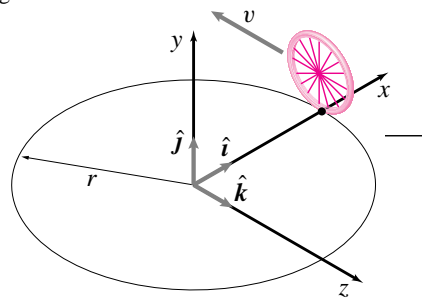

problem 12.51:

(Filename:pfigure.blue.90.2)

12.52 Rolling disk presses down. A rigid disk (idealized as flat) with radius R and mass m is rigidly attached (welded) to a rigid massless stick with length L which is connected by a ball-and-socket joint to the support at point O . The wheel rolls on a horizontal surface. Point O is at the height of the center of the wheel. The stick revolves around O at a rate of ω . Say gravity is negligible and, even though the wheel is rolling, you may assume there are no frictional

forces acting between the wheel and the horizontal surface. What is the vertical reaction on the bottom of the wheel? *

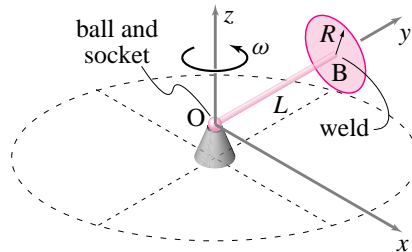

problem 12.52:

(Filename:s92f1p7)

12.53 In problem 12.29, find the angular momentum and rate of change of angular momentum of the two disks about point O . Assume that the mass of each disk is m .

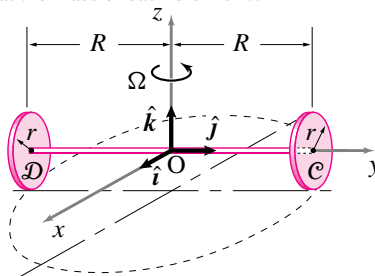

problem 12.53:

(Filename:twodisks.ang.mom)

12.54 A vehicle of mass m , width b , and height h rolls without slip along a road which runs into the page (along the z -axis.) The inertial properties about the vehicle center of mass are $I_{xx}^{cm}, I_{yy}^{cm}, I_{zz}^{cm}$, and $I_{xy}^{cm} = I_{xz}^{cm} = I_{yz}^{cm} = 0$. Make additional assumptions as needed to get an answer to the problem. Compute the contact forces acting on each wheel normal to the road in the following cases:

- The vehicle moves at constant speed v along a straight road.
- The vehicle moves at constant speed v along a circular road (radius ρ) curving to the left. Does the right or left wheel experience the larger force?

Rear end view

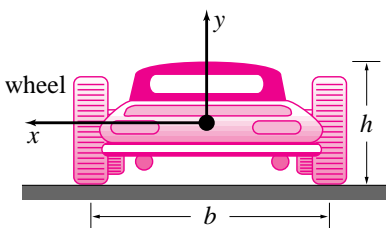

problem 12.54:

(Filename:pfigure.blue.90.1)

12.55 A car drives counter-clockwise in circles at constant speed V . The radius of the circle that the left rear wheel travels on is R . The radius of the wheel is r . Just when the wheel is rolling due north a pebble of mass m , which is stuck in the tread, is passing directly above the

wheel axle. (You should assume that the wheel axle is horizontal, that the wheel rolls without slip and that the wheel deformation and gravity are negligible.) At this instant, what is the force that the tread causes on the pebble? Resolve this force into east, north and upwards components. [Hint: several intermediate calculations are probably required.]

12.56 A child constructs a spinning top from a solid sphere with radius a and mass m attached to a massless rod of length $2d$. The sphere pivots freely about O . It is set spinning with a constant rate $\dot{\phi}$ and precessing with a constant rate $\dot{\psi}$. The top of the rod is held by a horizontal cord.

Note: The moments of inertia of a solid sphere of mass m and radius a about any axis through the center is $(2/5)ma^2$. (All products of inertia are zero, due to symmetry.)

- Using an axis system attached as shown (z lies along the shaft, x is out of the page and y is chosen to produce a right-handed system), write the body's angular velocity $\vec{\omega}$ as well as the angular velocity $\vec{\Omega}$ of the moving coordinate system relative to inertial space.
- What is the sphere's inertia tensor about O ?
- What is the top's angular momentum about O ?
- Compute the tension in the cord.

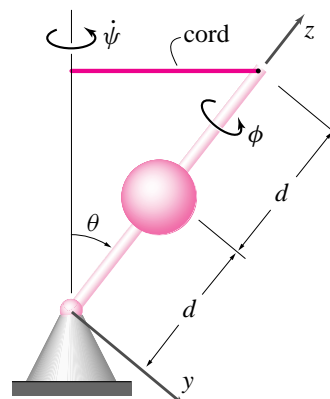

problem 12.56:

(Filename:pfigure.blue.110.1)

12.57 A thin disk of mass m and radius R is connected by a massless shaft of length L to a free swivel joint at O . The disk spins about the shaft at rate ω and proceeds in a steady slow precession (rate Ω) about the vertical.

- Write the disk's inertia tensor about O . Specify the axes that you have chosen.
- Write the disk's angular momentum about O , \vec{H}_O , in the same coordinate system.
- Calculate the rate of change of angular momentum about O , $\dot{\vec{H}}_O$.
- Compute the precession rate Ω for the slow precession case ($\omega \gg \Omega$).

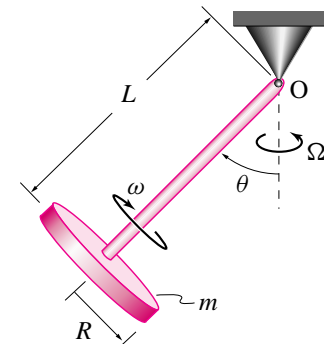

problem 12.57:

(Filename:pfigure.blue.107.1)

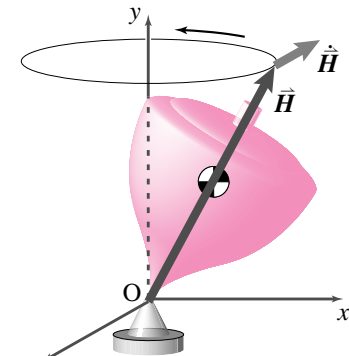

problem 12.58:

(Filename:pfigure.s94h14p4)

12.58 Spinning and precessing top. (hard question) The picture schematically shows what is going on when a spinning top is in steady precession. The top is, approximately, spinning at constant rate about its symmetry axis. This axis is in turn (so to speak) rotating about the y axis at a constant rate. This rotation about the y axis is called precession. The angular momentum vector thus changes in time as the top precesses and the angular momentum vector also precesses. The picture is a reasonable approximation if the top is rotating much faster than it is precessing. The picture is not accurate if the precession rate is not much smaller than the rotation rate. Here are some questions to help you see why.

- If the top is precessing as well as spinning what is the direction of the angular velocity vector?
- What is the direction of the angular momentum vector of the top? Is it parallel to the top's axis? Is it parallel to the angular velocity vector?
- How does the angular momentum vector differ from that shown in the figure?
- Does this difference affect any predictions about the precession rate of a spinning top?
- Assume the top is on a pedestal and is horizontal as it precesses. In this case the correct precession rate $\dot{\theta}$ is predicted by the naive/approximate theory that the angular momentum is just that due to spin and that this vector precesses with the top axis. Why does this simplification happen to work?

12.59 An amusement park ride consists of two cylinder-shaped cars of length $\ell = 8$ ft and radius $r = 3$ ft mounted at opposite ends of a long arm of length $2h = 20$ ft which is pivoted at its center as shown in the figure. The arm is constrained to rotate about the horizontal axle $O - O$. Each car can also rotate about its own axis. Car A, presently at the top of its flight, is spinning (much to the discomfort of its occupants) on its own axis as shown at a constant rate of $\omega_2 = 5$ rad/s relative to the vertical arm. The vertical arm is rotating about axis $O - O$ at the rate $\omega_1 = 0.5$ rad/s in the direction shown, as seen by a ground observer. The point P , located at $x = a = 2$ ft and $z = b = 1$ ft and representing a point in the inner ear of a passenger, is undergoing absolute velocity and acceleration \vec{v}_P and \vec{a}_P , respectively. Find the vectors \vec{v}_P and \vec{a}_P . (If you are using a moving coordinate system to determine \vec{v}_P and \vec{a}_P , state clearly how it moves).

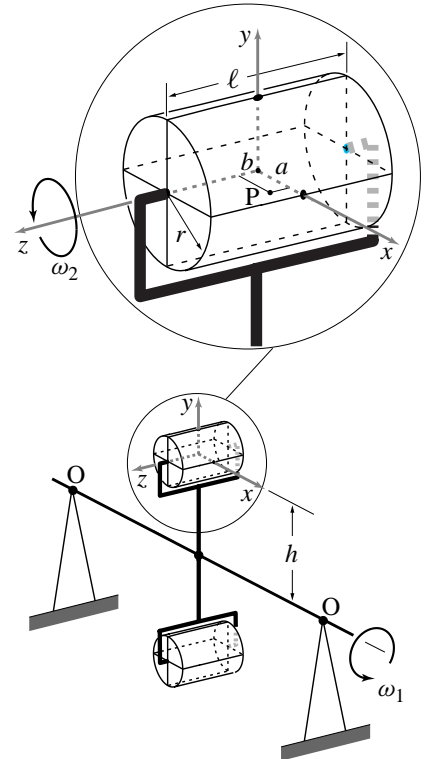

problem 12.59:

(Filename:pfigure.blue.122.1)

12.60 buzzing coin If you drop a round coin it will often go round and round progressively faster before buzzing to a stop. In terms of parameters you define, what is the frequency of this buzzing as a function of the tip angle? This problem is more subtle than a straightforward calculation as there are many solutions for a coin rolling at a given tip angle in circles. What feature picks out the solutions that are observed with real coins?

12.8 Motion relative to the earth

12.61 Estimate the sideways force (Pounds or Newtons) required for a person to walk a straight marked path over the North pole. Radius of earth ≈ 4000 miles $\approx 2 \times 10^7$ feet $\approx 6 \times 10^6$ meters. Make other simplifying approximations so that you can do the arithmetic without a calculator.

12.62 Foucault pendulum

12.63 Estimating the error of using the earth as a Newtonian frame

12.64 The path of an air mass sliding on a frictionless earth

Answers to *'d problems

- 2.33) $r_x = \vec{r} \cdot \hat{i} = (3 \cos \theta + 1.5 \sin \theta)$ ft, $r_y = \vec{r} \cdot \hat{j} = (3 \sin \theta - 1.5 \cos \theta)$ ft.
- 2.68) No partial credit.
- 2.69) To get chicken road sin theta.
- 2.74) $\vec{N} = \frac{1000\text{N}}{\sqrt{3}}(\hat{i} + \hat{j} + \hat{k})$.
- 2.77) $d = \sqrt{\frac{3}{2}}$.
- 2.81a) $\hat{\lambda}_{OB} = \frac{1}{\sqrt{50}}(4\hat{i} + 3\hat{j} + 5\hat{k})$.
- b) $\hat{\lambda}_{OA} = \frac{1}{\sqrt{34}}(3\hat{j} + 5\hat{k})$.
- c) $\vec{F}_1 = \frac{5\text{N}}{\sqrt{34}}(3\hat{j} + 5\hat{k})$, $\vec{F}_2 = \frac{7\text{N}}{\sqrt{50}}(4\hat{i} + 3\hat{j} + 5\hat{k})$.
- d) $\angle AOB = 34.45$ deg.
- e) $F_{1x} = 0$
- f) $\vec{r}_{DO} \times \vec{F}_1 = \left(\frac{100}{\sqrt{34}}\hat{j} - \frac{60}{\sqrt{34}}\hat{k}\right)$ N·m.
- g) $M_\lambda = \frac{140}{\sqrt{50}}$ N·m.
- h) $M_\lambda = \frac{140}{\sqrt{50}}$ N·m.(same as (7))
- 2.83a) $\hat{n} = \frac{1}{3}(2\hat{i} + 2\hat{j} + \hat{k})$.
- b) $d = 1$.
- c) $\frac{1}{3}(-2, 19, 11)$.
- 2.94) (0.5 m, -0.4 m)
- 4.2) $T_1 = Nmg$, $T_2 = (N - 1)mg$, $T_N = (1)mg$, and in general $T_n = (N + 1 - n)mg$
- 4.3) Surprise! This pendulum is in equilibrium for all values of θ .
- 4.8) Yes.
- 4.17a) $\frac{m}{M} = \frac{R \sin \theta}{R \cos \theta + r} = \frac{2 \sin \theta}{1 + 2 \cos \theta}$.
- b) $T = mg = 2Mg \frac{\sin \theta}{1 + 2 \cos \theta}$.
- c) $\vec{F}_C = Mg \left[-\frac{2 \sin \theta}{2 \cos \theta + 1} \hat{i}' + \hat{j}' \right]$ (where \hat{i}' and \hat{j}' are aligned with the horizontal and vertical directions)
- d) $\tan \phi = \frac{\sin \theta}{2 + \cos \theta}$. Needs somewhat involved trigonometry, geometry, and algebra.
- e) $\tan \psi = \frac{m}{M} = \frac{2 \sin \theta}{1 + 2 \cos \theta}$.
- 4.18a) $\frac{m}{M} = \frac{R \sin \theta}{R \cos \theta - r} = \frac{2 \sin \theta}{2 \cos \theta - 1}$.
- b) $T = mg = 2Mg \frac{\sin \theta}{2 \cos \theta - 1}$.
- c) $\vec{F}_C = \frac{Mg}{1 - 2 \cos \theta} [\sin \theta \hat{i} + (\cos \theta - 2) \hat{j}]$.
- 4.21a) $\frac{F_1}{F_2} = \frac{R_o + R_i \sin \phi}{R_o - R_i \sin \phi}$
- b) For $R_o = 3R_i$ and $\mu = 0.2$, $\frac{F_1}{F_2} \approx 1.14$.
- c) $\frac{F_1}{F_2} = e^{\mu \theta} = e^{0.2\pi} \approx 1.87$.
- 4.23) (a) $T_{AB} = 30$ N, (b) $T_{AB} = \frac{300}{17}$ N, (c) $T_{AB} = \frac{5\sqrt{26}}{2}$ N
- 4.25g) $T_{EH} = 0$ as you can find a number of ways.
- 5.5) $x(3\text{ s}) = 20$ m
- 5.22) $h_{max} = e^2 h$.
- 5.34) (a) $m\ddot{x} + kx = F(t)$, (b) $m\ddot{x} + kx = F(t)$, and (c) $m\ddot{y} + 2ky - 2k\ell_0 \frac{y}{\sqrt{\ell_0^2 + y^2}} = F(t)$
- 5.37b) $mg - k(x - \ell_0) = m\ddot{x}$
- c) $\ddot{x} + \frac{k}{m}x = g + \frac{k\ell_0}{m}$
- e) This solution is the static equilibrium position; i.e., when the mass is hanging at rest, its weight is exactly balanced by the upwards force of the spring at this constant position x .
- f) $\ddot{x} + \frac{k}{m}x = 0$
- g) $x(t) = \left[D - \left(\ell_0 + \frac{mg}{k} \right) \right] \cos \sqrt{\frac{k}{m}} t + \left(\ell_0 + \frac{mg}{k} \right)$
- h) period = $2\pi \sqrt{\frac{m}{k}}$.
- i) If the initial position D is more than $\ell_0 + 2mg/k$, then the spring is in compression for part of the motion. A floppy spring would buckle.
- 5.39a) period = $\frac{2\pi}{\sqrt{\frac{k}{m}}} = 0.96$ s
- b) maximum amplitude = 0.75 ft
- c) period = $2\sqrt{\frac{2h}{g}} + \sqrt{\frac{m}{k}} \left[\pi + 2 \tan^{-1} \sqrt{\frac{mg}{2kh}} \right] \approx 1.64$ s.
- 5.41) LHS of Linear Momentum Balance: $\sum \vec{F} = -(kx + b\dot{x})\hat{i} + (N - mg)\hat{j}$.
- 5.55a) Two normal modes.
- b) $x_2 = \text{const} * x_1 = \text{const} * (A \sin(ct) + B \cos(ct))$, where $\text{const} = \pm 1$.
- c) $\omega_1 = \sqrt{\frac{3k}{m}}$, $\omega_2 = \sqrt{\frac{k}{m}}$.
- 5.56a) $\begin{bmatrix} m_1 & 0 \\ 0 & m_2 \end{bmatrix} \begin{Bmatrix} \ddot{x}_1 \\ \ddot{x}_2 \end{Bmatrix} + \begin{bmatrix} k_1 + k_2 & -k_2 \\ -k_2 & k_2 + k_3 \end{bmatrix} \begin{Bmatrix} x_1 \\ x_2 \end{Bmatrix} = \begin{Bmatrix} 0 \\ 0 \end{Bmatrix}$
- b) If we start off by assuming that each mass undergoes simple harmonic motion at the same frequency but different amplitudes, we will find that this two-degree-of-freedom system has two natural frequencies. Associated with each natural frequency is a fixed ratio between the amplitudes of each mass. Each mass will undergo simple harmonic motion at one of the two natural frequencies only if the initial displacements of the masses are in the fixed ratio associated with that frequency.
- 5.58) $\vec{a}_B = \ddot{x}_B \hat{i} = \frac{1}{m_B} [-k_4 x_B - k_2(x_B - x_A) + c_1(\dot{x}_D - \dot{x}_B) + k_3(x_D - x_B)] \hat{i}$.

$$5.59) \vec{a}_B = \ddot{x}_B \hat{i} = \frac{1}{m_B} [-k_4 x_B - c_1(\dot{x}_B - \dot{x}_A) + (k_2 + k_3)(x_D - x_B)].$$

$$5.62a) \omega = \sqrt{\frac{2k}{m}}.$$

5.66a) One normal mode: [1, 0, 0].

b) The other two normal modes: [0, 1, $\frac{1 \pm \sqrt{17}}{4}$].

$$5.72a) \vec{v}(5\text{ s}) = (30\hat{i} + 300\hat{j}) \text{ m/s}.$$

$$b) \vec{a}(5\text{ s}) = (6\hat{i} + 120\hat{j}) \text{ m/s}^2.$$

$$5.73) \vec{r}(t) = (x_0 + \frac{u_0}{\Omega} - \frac{u_0}{\Omega} \cos(\Omega t)) \hat{i} + (y_0 + v_0 t) \hat{j}.$$

$$5.81) \vec{v} = 2t \text{ m/s}^2 \hat{i} + e^{\frac{t}{5}} \text{ m/s} \hat{j}, \vec{a} = 2 \text{ m/s}^2 \hat{i} + e^{\frac{t}{5}} \text{ m/s}^2 \hat{j}.$$

$$5.118) T_3 = 13 \text{ N}$$

5.131) Equation of motion:

$$-mg\hat{j} - b(\dot{x}^2 + \dot{y}^2) \left(\frac{\dot{x}\hat{i} + \dot{y}\hat{j}}{\sqrt{\dot{x}^2 + \dot{y}^2}} \right) = m(\ddot{x}\hat{i} + \ddot{y}\hat{j}).$$

5.132a) System of equations:

$$\dot{x} = v_x$$

$$\dot{y} = v_y$$

$$\dot{v}_x = -\frac{b}{m} v_x \sqrt{v_x^2 + v_y^2}$$

$$\dot{v}_y = -g - \frac{b}{m} v_y \sqrt{v_x^2 + v_y^2}$$

5.143) No. You need to know the angular momenta of the particles relative to the center of mass to complete the calculation, information which is not given.

$$5.154a) v_0 = \frac{1}{m}(m v_B + m_B v_B + m_A v_A).$$

$$b) v_1 = \frac{(m+m_B)}{m} v_B.$$

$$c) (1) E_{loss} = \frac{1}{2} m [v_0^2 - (\frac{m+m_B}{m} v_B)^2] - \frac{1}{2} m_A v_A^2.$$

$$E_{loss} = \frac{1}{2} m \left[\frac{(m+m_B)^2}{m} v_B^2 - (m+m_B) v_B^2 \right].$$

$$5.155) v_A = \sqrt{\frac{m_B k \delta^2}{m_A^2 + m_B m_A}}.$$

$$6.3) T_n = \frac{P_L}{v_t} \frac{n}{N}.$$

$$6.9a) a_B = \left(\frac{m_B - m_A}{m_A + m_B} \right) g$$

$$b) T = 2 \frac{m_A m_B}{m_A + m_B} g.$$

6.13) (a) $\vec{a}_A = \vec{a}_B = \frac{F}{m} \hat{i}$, where \hat{i} is parallel to the ground and pointing to the right., (b) $\vec{a}_A = \frac{2F}{m} \hat{i}$, $\vec{a}_B = \frac{4F}{m} \hat{i}$,

$$(c) \vec{a}_A = \frac{F}{2m} \hat{i}, \vec{a}_B = \frac{F}{4m} \hat{i}, (d) \vec{a}_A = \frac{F}{m} \hat{i}, \vec{a}_B = -\frac{F}{m} \hat{i}.$$

6.15) ratio of the acceleration of A to that of point B, $\frac{a_A}{a_B} = 81$.

6.18a) $\vec{a}_A = \frac{5F}{m} \hat{i}$, $\vec{a}_B = \frac{25F}{m} \hat{i}$, where \hat{i} is parallel to the ground and points to the right.

b) $\vec{a}_A = \frac{g}{(4m_1 + m_2)} (2m_2 - \sqrt{3}m_2) \hat{\lambda}_1$, $\vec{a}_B = -\frac{g}{2(4m_1 + m_2)} (2m_2 - \sqrt{3}m_2) \hat{\lambda}_2$, where $\hat{\lambda}_1$ is parallel to the slope that mass m_1 travels along, pointing down and to the left, and $\hat{\lambda}_2$ is parallel to the slope that mass m_2 travels along, pointing down and to the right.

6.22) angular frequency of vibration $\equiv \lambda = \sqrt{\frac{64k}{65m}}$.

6.27a) $m\ddot{x} + 4kx = A \sin \omega t + mg$, where x is the distance measured from the unstretched position of the center of the pulley.

b) The string will go slack if $\omega > \sqrt{\frac{4k}{m} \left(1 - \frac{A}{mg} \right)}$.

$$6.28a) \vec{a}_A = -\frac{9kd}{m_A} \hat{i}.$$

$$b) v = 3d \sqrt{\frac{k}{m_A}}$$

$$6.33) T_{AB} = \frac{5\sqrt{39}}{28} m (a_y + g)$$

$$6.36) a_x > \frac{3}{2} g$$

6.39) Can't solve for T_{AB} .

6.51d) Normal reaction at rear wheel: $N_r = \frac{mgw}{2(h\mu+w)}$, normal reaction at front wheel: $N_f = mg - \frac{mgw}{2(h\mu+w)}$, deceleration of car: $a_{car} = -\frac{\mu gw}{2(h\mu+w)}$.

e) Normal reaction at rear wheel: $N_r = mg - \frac{mgw}{2(w-\mu h)}$, normal reaction at front wheel: $N_f = \frac{mgw}{2(w-\mu h)}$, deceleration of car: $a_{car} = -\frac{\mu gw}{2(w-\mu h)}$. Car stops more quickly for front wheel skidding. Car stops at same rate for front or rear wheel skidding if $h = 0$.

f) Normal reaction at rear wheel: $N_r = \frac{mg(w/2-\mu h)}{w}$, normal reaction at front wheel: $N_f = \frac{mg(w/2+\mu h)}{w}$, deceleration of car: $a_{car} = -\mu g$.

g) No. Simple superposition just doesn't work.

h) No reaction at rear wheel.

i) Reaction at rear wheel is negative. Not allowing for rotation of the car in the xy -plane gives rise to this impossibility. In actuality, the rear of the car would flip over the front.

6.52a) $\vec{a} = g(\sin \phi - \mu \cos \phi) \hat{i}$, where \hat{i} is parallel to the slope and pointing downwards

$$b) \vec{a} = g \sin \phi$$

$$c) \vec{v} = g(\sin \phi - \mu \cos \phi) t \hat{i}, \vec{r} = g(\sin \phi - \mu \cos \phi) \frac{t^2}{2} \hat{i}$$

$$d) \vec{v} = g \sin \phi t \hat{i}, \vec{r} = g \sin \phi \frac{t^2}{2} \hat{i}$$

$$6.54a) \vec{R}_A = \frac{(1-\mu)mg \cos \theta}{2} (\hat{j} - \mu \hat{i}').$$

c) No tipping if $N_A = \frac{(1-\mu)mg \cos \theta}{2} > 0$; i.e., no tipping if $\mu < 1$ since $\cos \theta > 0$ for $0 < \theta < \frac{\pi}{2}$. (Here $\mu = 0.9$)

6.56) braking acceleration = $g(\frac{1}{2} \cos \theta - \sin \theta)$.

$$6.60a) v = d \sqrt{\frac{k}{m}}.$$

b) The cart undergoes simple harmonic motion for any size oscillation.

$$6.63a) \vec{a}_{bike} = \frac{F_p L_c}{MR_f}.$$

$$b) \max(\vec{a}_{bike}) = \frac{ga}{a+b+2R_f}.$$

$$6.64) T_{EF} = 640\sqrt{2} \text{ lbf}.$$

$$6.65a) T_{BD} = 92.6 \text{ lbm} \cdot \text{ft/s}^2.$$

$$b) T_{GH} = 5\sqrt{61} \text{ lbm} \cdot \text{ft/s}^2.$$

$$6.66b) T_{EH} = 0$$

$$c) (R_{C_x} - T_{AB}) \hat{i} + (R_{C_y} - \frac{T_{GD}}{\sqrt{2}}) \hat{j} + (T_{HE} + R_{C_z} + \frac{T_{GD}}{\sqrt{2}}) \hat{k} = m \vec{a} = 10 N \hat{k}.$$

d) $\sum \vec{M}_{cm} = (\frac{T_{GD}}{\sqrt{2}} - T_{HE} - R_{C_z})\hat{i} + (R_{C_z} - \frac{T_{GD}}{\sqrt{2}} - T_{HE})\hat{j} + (T_{AB} + R_{C_x} - R_{C_y} - \frac{T_{GD}}{\sqrt{2}})\hat{k} = \vec{0}$

e)

$$\begin{aligned} R_{C_x} - T_{AB} &= 0 \\ R_{C_y} - \frac{T_{GD}}{\sqrt{2}} &= 0 \\ R_{C_z} + \frac{T_{GD}}{\sqrt{2}} + T_{EH} &= 5N \\ -T_{EH} + \frac{T_{GD}}{\sqrt{2}} - R_{C_z} &= 0 \\ -T_{EH} - \frac{T_{GD}}{\sqrt{2}} + R_{C_z} &= 0 \\ T_{AB} - \frac{T_{GD}}{\sqrt{2}} + R_{C_x} - R_{C_y} &= 0 \end{aligned}$$

f) $R_{C_x} = 5N, R_{C_y} = 5N, R_{C_z} = 5N, T_{GD} = \frac{10}{\sqrt{2}}N, T_{EH} = 0N, T_{AB} = 5N.$

g) Find moment about CD axis; e.g., $(\sum \vec{M}_C = \vec{r}_{cm/C} \times m\vec{a}_{cm}) \cdot \hat{\lambda}_{CD}$, where $\hat{\lambda}_{CD}$ is a unit vector in the direction of axis CD.

6.71a) $F_L = \frac{1}{2}m_{tot}g.$

b) $\vec{a}_P = \frac{1}{m_{tot}} [2(T - F_D) - D]\hat{i}.$

c) $\vec{F} = \left[\frac{m_w}{m_{tot}}(2T - D - 2F_D) - T + F_D \right]\hat{i} + (m_w g - F_L)\hat{j}$ and $\vec{M} = (bF_L - am_w g)\hat{i} + [(bF_D - cT) + a\frac{m_w}{m_{tot}}(2T - D - 2F_D)]\hat{j}.$

6.72) sideways force = $F_B\hat{i} = \frac{um_a}{2\ell}\hat{i}.$

7.3)

- one solution is $\vec{r} = R(\cos(\omega t)\hat{i} + \sin(\omega t)\hat{j})$ with R and ω constants,
- another solution is $\vec{r} = [At\hat{i} + Bt^2\hat{j}]/\sqrt{1 + 4B^2t^2/A^2},$
- general solution is any motion where speed = $v = |\vec{v}|$ is a constant.

7.17) $F = 0.52 \text{ lbf} = 2.3 N$

7.24b) For $\theta = 0^\circ,$

$$\begin{aligned} \hat{e}_r &= \hat{i} \\ \hat{e}_t &= \hat{j} \\ \vec{v} &= \frac{2\pi r}{\tau} \hat{j} \\ \vec{a} &= -\frac{4\pi^2 r}{\tau^2} \hat{i}, \end{aligned}$$

for $\theta = 90^\circ,$

$$\begin{aligned} \hat{e}_r &= \hat{j} \\ \hat{e}_t &= -\hat{i} \\ \vec{v} &= -\frac{2\pi r}{\tau} \hat{i} \\ \vec{a} &= -\frac{4\pi^2 r}{\tau^2} \hat{j}, \end{aligned}$$

and for $\theta = 210^\circ,$

$$\begin{aligned} \hat{e}_r &= -\frac{\sqrt{3}}{2}\hat{i} - \frac{1}{2}\hat{j} \\ \hat{e}_t &= \frac{1}{2}\hat{i} - \frac{\sqrt{3}}{2}\hat{j} \\ \vec{v} &= -\frac{\sqrt{3}\pi r}{\tau} \hat{j} + \frac{\pi r}{\tau} \hat{i} \\ \vec{a} &= \frac{2\sqrt{3}\pi^2 r}{\tau^2} \hat{i} + \frac{2\pi^2 r}{\tau^2} \hat{j}. \end{aligned}$$

c) $T = \frac{4m\pi^2 r}{\tau^2}.$

d) Tension is enough.

7.27b) $(\vec{H}_O)_I = \vec{0}, (\vec{H}_O)_{II} = 0.0080 N \cdot m \hat{k}.$

c) Position-A: $(\vec{H}_O)_I = 0.012 N \cdot m \cdot s\hat{k}, (\vec{H}_O)_{II} = 0.012 N \cdot m \cdot s\hat{k},$ Position-B: $(\vec{H}_O)_I = 0.012 N \cdot m \cdot s\hat{k}, (\vec{H}_O)_{II} = 0.014 N \cdot m \cdot s\hat{k}.$

7.29) $r = \frac{kr_o}{k - m\omega_o^2}.$

7.31) $\ell_0 = 0.2 \text{ m}$

7.33b) $T = 0.16\pi^4 N.$

c) $\vec{H}_O = 0.04\pi^2 \text{ kg} \cdot \text{m}/s\hat{k}$

d) $\vec{r} = [\frac{\sqrt{2}}{2} - v \cos(\frac{\pi t}{4})]\hat{i} + [\frac{\sqrt{2}}{2} + v \sin(\frac{\pi t}{4})]\hat{j}.$

7.35a) $2mg.$

b) $\omega = \sqrt{99g/r}$

c) $r \approx 1 \text{ m} (r > 0.98 \text{ m})$

7.38) (b) $\ddot{\theta} + \frac{3g}{2L} \sin \theta = 0$

7.41b) The solution is a simple multiple of the person's weight.

7.43a) $\ddot{\theta} = -(g/L) \sin \theta$

d) $\dot{\alpha} = -(g/L) \sin \theta, \quad \dot{\theta} = \alpha$

f) $T_{max} = 30N$

7.44a) $\dot{v} = -\mu \frac{v^2}{R}.$

b) $v = v_0 e^{-\mu\theta}.$

7.47a) The velocity

of departure is $\vec{v}_{dep} = \sqrt{\frac{k(\Delta\ell)^2}{m} - 2GR}\hat{j},$ where \hat{j} is perpendicular to the curved end of the tube.

b) Just before leaving the tube the net force on the pellet is due to the wall and gravity, $\vec{F}_{net} = -mg\hat{j} - m\frac{|\vec{v}_{dep}|^2}{R}\hat{i};$ Just after leaving the tube, the net force on the pellet is only due to gravity, $\vec{F}_{net} = -mg\hat{j}.$

7.51) $\vec{a}_t = 20 \text{ in}/s^2 \hat{j}, \quad \vec{a}_n = -250 \text{ in}/s^2 \hat{i}.$

7.65) $\omega_{min} = 10 \text{ rpm}$ and $\omega_{max} = 240 \text{ rpm}$

7.76a) 7.85 kW

b) 7.85 kW

c) 750 rev/min

d) 100 N·m.

7.79a) $v_P = 2 \text{ m}/s.$

b) $\vec{v}_P = -2 \text{ m}/s\hat{i}.$

c) $\vec{a}_P = -4 \text{ m}/s^2 \hat{j}.$

d) $\vec{v}_r = 1 \text{ m}/s\hat{\lambda}_r,$ where $\hat{\lambda}_r$ is a unit vector pointing in the direction of the rack, down and to the right.

e) No force needed to move at constant velocity.

7.80a) $P_{in} = 7.33$ kilo-watts

b) 500 rpm

c) $M_{out} = 140$ N·m

7.84a) $\alpha_B = 20$ rad/s² (CW)

b) $a = 4$ m/s² (up)

c) $T = 280$ N.

7.86a) $F_B = 100$ lbf.

c) $v_{right} = v$.

7.94b)

(b) $T = 2.29$ s

(e) $T = 1.99$ s

(b) has a longer period than (e) does since in (b) the moment of inertia about the center of mass (located at the same position as the mass in (e)) is non-zero.

7.98a) $\ddot{\theta} = 0$ rad/s².

b) $\ddot{\theta} = \frac{\sin\theta}{m\ell}(Dk - mg)$.

7.99b) $-F(t)\ell \cos\phi - mg\ell \sin\phi + T_m = -m\ell^2\ddot{\phi}$.

7.100a) (a) $\vec{F} = 0.33$ N $\hat{i} - 0.54$ N \hat{j} .

7.101a) $T(r) = \frac{m\omega^2}{2L}(L^2 - r^2)$

b) at $r = 0$; i.e., at the center of rotation

c) $r = L/\sqrt{2}$

7.103) $I_{zz} = 0.125$ kg · m².

7.104a) 0.2 kg · m².

b) 0.29 m.

7.105) At 0.72ℓ from either end

7.106a) $(I_{zz})_{min} = m\ell^2/2$, about the midpoint.

b) $(I_{zz})_{max} = m\ell^2$, about either end

7.107a) C

b) A

c) $I_{zz}^A/I_{zz}^B = 2$

d) smaller, $r_{gyr} = \sqrt{I_{zz}^C/(3m)} = \sqrt{2}\ell$

7.108a) Biggest: I_{zz}^O ; smallest: $I_{yy}^O = I_{xx}^O$.

b) $I_{xx}^O = \frac{3}{2}m\ell^2 = I_{yy}^O$. $I_{zz}^O = 3m\ell^2$.

d) $r_{gyr} = \ell$.

7.113a) $\omega_n = \sqrt{\frac{gL(M+\frac{m}{2})+K}{(M+\frac{m}{3})L^2+M\frac{R^2}{2}}}$.

b) $\omega_n = \sqrt{\frac{gL(M+\frac{m}{2})+K}{(M+\frac{m}{3})L^2}}$. Frequency higher than in (a)

7.114a) $I_{zz}^{cm} = 2m\ell^2$

b) $P \equiv A, B, C$, or D

c) $r_{gyr} = \ell/\sqrt{2}$

7.115) $I_{xx}^O = I_{yy}^O = 0.3$ kg · m².

7.117a) $I_{zz}^O = \frac{2m}{bh} \int_0^b \int_0^b (x^2 + y^2) dy dx$.

7.128a) Point at $2L/3$ from A

b) $mg/4$ directed upwards.

7.129c) $T = \frac{2\pi}{\sqrt{g/\ell}} \sqrt{\frac{1}{12(d/\ell)} + \frac{d}{\ell}}$

g) $d = 0.29\ell$

7.132a) Net force: $\vec{F}_{net} = -(3\frac{m\omega^2 L}{2})\hat{i} - (\frac{m\omega^2 L}{2})\hat{j}$, Net moment: $\vec{M}_{net} = \vec{0}$.

b) Net force: $\vec{F}_{net} = -(3\frac{m\omega^2 L}{2})\hat{i} + (2mg - \frac{m\omega^2 L}{2})\hat{j}$,

Net moment: $\vec{M}_{net} = \frac{3mgL}{2}\hat{k}$.

7.133) $T_{rev} = \sqrt{\frac{2M_0\ell^2\pi}{3FR_p}}$.

7.139) period = $\pi\sqrt{\frac{2m}{k}}$.

7.141a) $\vec{\alpha} = \ddot{\theta}\hat{k} = ?$ rad/s² \hat{k} (oops).

b) $T = 538$ N.

7.142) $\vec{v}_B = \sqrt{\frac{2gh[m_B - 2m_A(\sin\theta + \mu\cos\theta)]}{[4m_A + m_B + 4m_C(\frac{K_C}{R_C})^2]}}$.

7.143) $\vec{a}_m = 0.188$ m/s²

8.13a) $\vec{r}_{P/O} = 0.5$ m $[(\cos\phi)\hat{i} + \sin\phi\hat{j}]$.

b) $\vec{v}_P = (0.5\omega \sin\phi\hat{k})$ m/s,

$\vec{a}_P = (-0.5\omega^2 \sin\phi\hat{j})$ m/s².

8.23a) $T_{DB} = 0.9$ N.

b) $\vec{F}_A = -0.3$ N \hat{i} , $\vec{F}_C = -0.6$ N \hat{i}

c) Torque_{motor} = 0.

8.25a) Angles ϕ for steady circular motion are solutions to $10 \tan\phi = 8 + 40 \sin\phi$.

b) $\phi = [1.3627 \text{ rad}, -0.2735 \text{ rad}, -1.2484 \text{ rad}, -2, 9813 \text{ rad}]$, four solutions, found numerically. Graphically, the solutions are the interns of the curves $f_1(\phi) = 10 \tan\phi$ and $f_2(\phi) = 8 + 40 \sin\phi$ between $-\pi$ and π .

8.28b) Period of revolution = $\frac{2\pi}{\omega}$, Period of simple pendulum (for small oscillations) = $2\pi\sqrt{\frac{\ell}{g}}$, where ℓ is the length of the pendulum.

c) $T = m\omega^2 L$ (strange that ϕ drops out!), $\vec{v}_{rock} = -\omega L \sin\phi\hat{i}$, $\vec{a}_{rock} = -\omega^2 L \sin\phi\hat{j}$, $\frac{dH_x}{dt} = -m\omega L^2 \sin\phi \cos\phi$.

8.29) $\phi = \cos^{-1}(\frac{g}{\omega^2 L})$.

8.32) (a) $T = -69.2$ N, (b) 1.64 rad/s $< \omega < 3.47$ rad/s

8.36) $\Delta x = -0.554$ m

8.37b) $\vec{H}_O = -\frac{1}{12}m\omega^2\ell^2 \sin\phi \cos\phi\hat{k}$.

c) $\vec{F}_A = (\frac{1}{12}m\omega^2\ell^2/d \sin\phi \cos\phi)\hat{j}$, $\vec{F}_B = -\vec{F}_A$.

d) $\vec{F}_A = (\frac{1}{12}m\omega^2\ell^2/d \sin\phi \cos\phi + \frac{1}{2}mg)\hat{j}$, $\vec{F}_B \neq -\vec{F}_A$.

8.40) $T = \frac{\sqrt{2}m\omega^2 R}{6}$.

8.57a) $\vec{\omega} \times ([I^G] \cdot \vec{\omega}) = \vec{0}$ kg·m²/s².

b) $\vec{\omega} \times ([I^G] \cdot \vec{\omega}) = -25\hat{i}$ kg·m²/s².

8.66b) $\omega^2 = \frac{3g}{2L \cos\phi}$, $T_{rev} = \frac{2\pi}{\omega}$.

8.67a) $\omega^2 = \frac{3gn}{L(2n+1) \cos\phi}$.

8.68a)

$$[I^O] = mL^2 \begin{bmatrix} 4 & 0 & 0 \\ 0 & 2 & -2 \\ 0 & -2 & 2 \end{bmatrix},$$

in terms of the coordinate system shown.

b) $\vec{H}_O = 2mL^2\omega(-\hat{j} + \hat{k})$.

c) $\vec{H}_O = -2mL^2\omega^2\hat{i}$.

d) $\vec{F} = \vec{0}$, $\vec{M}_O = -2mL^2\omega^2\hat{i}$.

$$8.69c) \vec{R}_O = -\frac{m\omega^2 bh(b^2-h^2)}{12(b^2+h^2)^{\frac{3}{2}}} \hat{k} = -\vec{R}_C.$$

$$8.70a) \vec{a}_D = \frac{M_y}{I_{YY}^{cm}} \frac{2dc}{\sqrt{c^2+d^2}} \hat{i}.$$

$$b) \vec{B} = -\frac{M_y I_{YZ}^{cm}}{2I_{YY}^{cm} \sqrt{c^2+d^2}} \hat{i}.$$

$$8.79a) \vec{H}_O = (-0.108\hat{i}' + 0.126\hat{k}') \text{ kg}\cdot\text{m}^2/\text{s}$$

b) \vec{H}_O is in the $x'z'$ plane at the moment of interest and at an angle $\alpha \approx 41^\circ$, clockwise from the z' -axis.

c) \vec{H}_O does not change in magnitude (m , R , ω , β are constants). \vec{H}_O rotates with the disk; i.e., it changes direction.

d) $\dot{\vec{H}}_O$ = the rate of change of \vec{H}_O . The tip of \vec{H}_O goes in a circle. At the instant of interest, the change will be in the \hat{j}' or \hat{j} direction. Thus, $\sum \vec{M}_O = \dot{\vec{H}}_O$ will be in the \hat{j} direction.

$$8.82a) \vec{H}_{cm} = \frac{9\sqrt{3}}{128} \text{ N}\cdot\text{m}\hat{j} = 0.122 \text{ N}\cdot\text{m}\hat{j}$$

$$b) \vec{H}_A = -26.89 \text{ N}\cdot\text{m}\hat{j}$$

$$c) \vec{R}_A = -4.56 \text{ N}\hat{i}, \vec{R}_C = -13.439 \text{ N}\hat{i}, M_z = 0.$$

8.90b) M_{Az} is always zero.

c) No. See problems 8.68 and 8.37 for counter-examples.

$$9.1) \text{ plot}(2): \theta(t) = br(t) \text{ and } \vec{v} = \frac{\theta}{b} \hat{e}_r + \frac{\theta\dot{\theta}}{b} \hat{e}_t.$$

$$9.1) \text{ plot}(2): x = r \cos(br) \text{ and } y = r \sin br \text{ or } x = \frac{\theta}{b} \cos(\theta) \text{ and } y = \frac{\theta}{b} \sin \theta$$

$$9.12) \vec{v}_P = \omega_1 L(\cos \theta \hat{j} - \sin \theta \hat{i}) + (\omega_1 + \omega_2)r\hat{i}, \vec{a}_P = -\omega_1^2 L(\cos \theta \hat{i} + \sin \theta \hat{j}) + (\omega_1 + \omega_2)^2 \hat{j}.$$

9.17a)

$$\hat{e}_t = \frac{\frac{2t}{s} \hat{i} + e^{\frac{t}{s}} \hat{j}}{\sqrt{4\frac{t^2}{s^2} + e^{\frac{2t}{s}}}}$$

$$a_t = \frac{4t \frac{m}{s^3} + e^{\frac{2t}{s}} m/s^2}{\sqrt{4\frac{t^2}{s^2} + e^{\frac{2t}{s}}}}$$

$$\vec{a}_n = \frac{(2 - 2\frac{t}{s})e^{\frac{2t}{s}} m/s^2 \hat{i} + (4\frac{t^2}{s^2} - 4\frac{t}{s})e^{\frac{t}{s}} m/s^2 \hat{j}}{4\frac{t^2}{s^2} + e^{\frac{2t}{s}}}$$

$$\hat{e}_n = \frac{e^{\frac{t}{s}} \hat{i} - 2\frac{t}{s} \hat{j}}{\sqrt{4\frac{t^2}{s^2} + e^{\frac{2t}{s}}}}$$

$$\rho = \frac{(4\frac{t^2}{s^2} + e^{\frac{2t}{s}})}{(2 - 2\frac{t}{s})e^{\frac{t}{s}}} \text{ m}$$

$$9.22a) \vec{a}_{cm} = \frac{F}{m} \hat{i}.$$

$$b) \vec{\alpha} = -\frac{6F}{m\ell} \hat{k}.$$

$$c) \vec{a}_A = \frac{4F}{m} \hat{i}.$$

$$d) \vec{F}_B = \frac{F}{2} \hat{i}$$

$$9.25a) \vec{a} = \frac{F}{m} \hat{j}.$$

$$b) \vec{\alpha} = \frac{Fd}{m\frac{R^2}{2}} \hat{k}.$$

$$9.34a) F_{out} = \frac{7}{3} \text{ lb.}$$

b) F_{out} is always less than the F_{in} .

$$9.38a) \vec{\alpha}_{Disk} = -\frac{4}{3} \text{ rad/s}^2 \hat{k}.$$

$$b) \vec{a}_A = \frac{8}{3} \text{ m/s}^2 \hat{i}.$$

$$9.40a) a_C = (F/m)(1 - R_i/R_O)\hat{i}.$$

$$b) (-R_i/R_O)F\hat{i}.$$

$$9.45a) \text{ speed } v = \frac{R\dot{\theta}}{3}.$$

b) The energy lost to friction is $E_{fric} = \frac{mR^2\dot{\theta}_0^2}{6}$. The energy lost to friction is independent of μ for $\mu > 0$. Thus, the energy lost to friction is constant for given m , R , and $\dot{\theta}_0$. As $\mu \rightarrow 0$, the transition time to rolling $\rightarrow \infty$. It is not true, however, that the energy lost to friction $\rightarrow 0$ as $\mu \rightarrow 0$. Since the energy lost is constant for any $\mu > 0$, the disk will slip for longer and longer times so that the distance of slip goes to infinity. The dissipation rate $\rightarrow 0$ since the constant energy is divided by increasing transition time. The energy lost is zero only for $\mu = 0$.

$$9.46) V = 2 \text{ m/s.}$$

$$9.47) v_o = 2\sqrt{\frac{2gR}{3}}.$$

9.53) Accelerations of the center of mass, where \hat{i} is parallel to the slope and pointing down: (a) $\vec{a}_{cm} = g \sin \theta \hat{i}$, (b) $\vec{a}_{cm} = \frac{2}{3}g \sin \theta \hat{i}$, (c) $\vec{a}_{cm} = \frac{1}{2}g \sin \theta \hat{i}$, (d) $\vec{a}_{cm} = \frac{2}{3}g \sin \theta \hat{i}$. So, the block is fastest, all uniform disks are second, and the hollow pipe is third.

$$9.65) h = 2L/3]$$

$$10.11) (g) \vec{v}_P = 8 \text{ m/s}\hat{i}, \vec{a}_P = \vec{0}; (h) \vec{v}_P = 3 \text{ m/s}\hat{i}, \vec{a}_P = \vec{0}.$$

$$10.12) \vec{a}_b = -(s^2A + a\omega_D^2 + 2\omega_D v_b)\hat{i} - a\dot{\omega}_D \hat{k}.$$

10.17b) One case: $\vec{a}_P = \vec{a}_{O'}$, where P refers to the bug; the bug stands still on the turntable, the truck accelerates, and the turntable does not rotate.

c) One case: $\vec{a}_P = \vec{a}_{O'} + \vec{a}_{P/\mathcal{D}}$, where \mathcal{D} is the turntable; the bug accelerates along a straight line on the turntable, the truck accelerates, and the turntable does not rotate.

$$10.18a) \vec{\omega}_{OA} = \dot{\theta} \hat{k}.$$

$$b) \vec{\alpha}_{OA} = \ddot{\theta} \hat{k}.$$

$$c) \vec{v}_A = -R\dot{\theta} \sin \theta \hat{i} + R\dot{\theta} \cos \theta \hat{j}.$$

$$d) \vec{a}_A = -(R\dot{\theta}^2 \cos \theta + R\ddot{\theta} \sin \theta)\hat{i} + (R\ddot{\theta} \cos \theta - R\dot{\theta}^2 \sin \theta)\hat{j}.$$

$$e) \vec{\omega}_{AB} = \frac{-R\dot{\theta} \cos \theta}{\sqrt{\ell^2 - R^2 \sin^2 \theta}}.$$

$$f) \theta = (2n + 1)\frac{\pi}{2}, n = 0, \pm 1, \pm 2, \dots$$

$$10.21) \vec{\omega}_{DE} = -\frac{\omega}{2} \hat{k} = -1.5 \text{ rad/s}\hat{k}$$

$$10.22) \vec{\alpha}_{DE} = 3.5 \text{ rad/s}^2 \hat{k}$$

10.29) One situation: $\vec{v} = R\dot{\theta} \hat{e}_\theta$; the case of a particle constrained to move in a circle.

10.30) One situation: $\vec{a} = \vec{R}\ddot{\theta}_R$; the case of no rotation ($\dot{\theta} = \ddot{\theta} = 0$).

$$10.31) \vec{\omega}_D = (\omega_1 + \omega_2)\hat{k}.$$

10.33a)

$$\hat{e}_t = \frac{\frac{2t}{s} \hat{i} + e^{\frac{t}{s}} \hat{j}}{\sqrt{4\frac{t^2}{s^2} + e^{\frac{2t}{s}}}}$$

$$a_t = \frac{4t \frac{m}{s^3} + e^{\frac{2t}{s}} m/s^2}{\sqrt{4\frac{t^2}{s^2} + e^{\frac{2t}{s}}}}$$

$$\vec{a}_n = \frac{(2 - 2\frac{t}{s})e^{\frac{2t}{s}} m/s^2 \hat{i} + (4\frac{t^2}{s^2} - 4\frac{t}{s})e^{\frac{t}{s}} m/s^2 \hat{j}}{4\frac{t^2}{s^2} + e^{\frac{2t}{s}}}$$

$$\hat{e}_n = \frac{e^{\frac{t}{s}} \hat{i} - 2\frac{t}{s} \hat{j}}{\sqrt{4\frac{t^2}{s^2} + e^{\frac{2t}{s}}}}$$

$$\rho = \frac{(4\frac{t^2}{s^2} + e^{\frac{2t}{s}})}{(2 - 2\frac{t}{s})e^{\frac{t}{s}}} m$$

11.9a) $\ddot{R}(t) - \omega_o^2 R(t) = 0.$

b) $\frac{d^2 R(\theta)}{d\theta^2} - R(\theta) = 0.$

c) $R(\theta = 2\pi) = 267.7 \text{ ft}, R(\theta = 4\pi) = 1.43 \times 10^5 \text{ ft}.$

d) $v = 2378.7 \text{ ft/s}$

e) $E_K = (2.83 \times 10^6) \times (mass)(\text{ft/s})^2.$

11.10a) $\ddot{R} = R_o \omega^2 - 2\mu \dot{R}_o \omega.$

b) $\phi = \sin^{-1} \left[\frac{1}{\sqrt{(\sqrt{1+\mu^2}-\mu)^2+1}} \right].$

11.19a) $\omega^- = 4 \text{ rad/s}$, where the minus sign ‘-’ means ‘just before leaving’.

b) $\omega^+ = 4 \text{ rad/s}$, where the plus sign ‘+’ means ‘just after leaving’.

c) $v_r = 3.841 \text{ m/s}, v_t = 2.4 \text{ m/s}.$

d) torque = 0.072 N·m

11.20) $\vec{F} = -0.6 \text{ N} \hat{j}.$

11.22a) $T_{BC} = m \sqrt{\frac{34}{13}} (2a_x + g).$

b) $\vec{a} = \frac{1}{34} [(25a_x + 15g)\hat{i} + (15a_x - 25g)\hat{j}]$

c) $T_{BC} = m \frac{1}{\sqrt{34}} (5a_x + 3g).$

11.28a) $\vec{H}_O = [mL^2 \omega_1 + \frac{1}{2}mr^2(\omega_1 + \omega_2)] \hat{k}.$

b) $\vec{H}_O = \vec{0}.$

c) $\vec{H}_C = \frac{1}{2}mr^2(\omega_1 + \omega_2) \hat{k}.$

d) $\vec{H}_C = \vec{0}.$

11.29) $\vec{F} = m\vec{a} = -109.3 \text{ N} \hat{i} - 19.54 \text{ N} \hat{j}.$

11.31b) $\ddot{\theta} = -\frac{3g}{2L} \cos \theta.$

c) From the diagram, we see $\dot{\omega}_{AB} = -\ddot{\theta}(t=0) \hat{k} = \frac{3g}{2L} \cos \theta_0$, $\vec{a}_G = \frac{3}{4}g \cos \theta_0 [\sin \theta_0 \hat{i} - \cos \theta_0 \hat{j}].$

d) $\vec{R}_A = \frac{3}{4}mg \sin \theta_0 \cos \theta_0 \hat{i}$, $\vec{R}_B = mg[1 - \frac{3}{4}g \cos^2 \theta_0] \hat{j}.$

e) $\vec{a}_B = \frac{3}{2}g \sin \theta_0 \cos \theta_0 \hat{i}.$

f) At $\theta = \frac{\theta_0}{2}$, $\vec{\omega}_{AB} = \sqrt{\frac{3g}{L}} (\sin \theta_0 - \sin \frac{\theta_0}{2}) \hat{k}$, $\vec{a}_A = -3g \left[\frac{1}{2} \cos^2 \frac{\theta_0}{2} + \sin \frac{\theta_0}{2} (\sin \theta_0 - \sin \frac{\theta_0}{2}) \right] \hat{j}.$

11.37) There are many solution methods. $-8\pi^2$ poundals to the left. (Note: 1 poundal = 1 ft · lbm · s⁻².)

11.40a) $\Delta = \sqrt{\frac{(M_c + 6M_w)v_0^2}{k}}.$

b) Tangential forces point toward the wall!

c) $\Delta = \sqrt{\frac{(M_c + 4M_w)v_0^2}{k}}.$

11.45a) $-k(x\hat{i} + y\hat{j}) = m(\ddot{x}\hat{i} + \ddot{y}\hat{j}).$

b) $-kr\hat{e}_r = m(\ddot{r} - r\dot{\theta}^2)\hat{e}_r + m(r\ddot{\theta} + 2\dot{r}\dot{\theta})\hat{e}_t.$

c) $\frac{d}{dt}(x\dot{y} - y\dot{x}) = 0.$

d) $\frac{d}{dt}(r^2\dot{\theta}) = 0.$

e) dot equation in (a) with $(x\hat{j} - y\hat{i})$ to get $(x\ddot{y} - y\ddot{x}) = 0$ which can be rewritten as (c); dot equation in (b) with \hat{e}_t to get $(r\ddot{\theta} + 2\dot{r}\dot{\theta}) = 0$ which can be rewritten as (d).

f) $\frac{1}{2}m(\dot{x}^2 + \dot{y}^2) + \frac{1}{2}k(x^2 + y^2) = \text{const}.$

g) $\frac{1}{2}m(\dot{r}^2 + (r\dot{\theta})^2) + \frac{1}{2}kr^2 = \text{const}.$

h) dot equation in (a) with $\vec{v} = \dot{x}\hat{i} + \dot{y}\hat{j}$ to get $m(\ddot{x}x + \ddot{y}y) + k(\dot{x}x + \dot{y}y) = 0$ which can be rewritten as (f).

i) $x = A_1 \sin(\omega t + B_1)$, $y = A_2 \sin(\omega t + B_2)$, where $\omega = \sqrt{\frac{k}{m}}$. The general motion is an ellipse.

j) Yes. Consider $B_1 = B_2 = 0$, $A_1 = 1$, and $A_2 = 2$.

11.46a) 0.33 m

b) $\vec{v}_C = 1.82 \text{ m/s} \hat{i}.$

c) $T \approx 240 \text{ N}.$

11.52b)

$$\begin{aligned} \ddot{R} - R\dot{\theta}^2 &= 0 \\ (I_{zz} + mR^2)\ddot{\theta} + 2mR\dot{R}\dot{\theta} &= 0 \end{aligned}$$

c) The second equation in part (b) can be rewritten in the form $\frac{d}{dt} [I_{zz} + mR^2]\dot{\theta} = 0$. The quantity inside the derivative is angular momentum; thus, it is conserved and equal to a constant, say, $(H/o)_0$, which can be found in terms of the initial conditions.

d) $\ddot{R} - R \left[\frac{(H/o)_0^2}{(I_{zz} + mR^2)^2} \right] = 0.$

e) $E_0 = \frac{1}{2}m\dot{R}^2 + \frac{1}{2}\omega(H/o)_0.$

f) The bead’s distance goes to infinity and its speed approaches a constant. The turntable’s angular velocity goes to zero and its net angle of twist goes to a constant.

11.53a)

$$\dot{\theta} = \omega$$

$$\dot{\omega} = -\frac{2mRv\omega}{I_{zz} + mR^2}$$

$$\dot{R} = v$$

$$\dot{v} = \omega^2 R$$

11.55) $v_{2x} = \sqrt{\frac{2g(a-b)\tan \phi}{(1+\frac{1}{n}+(\frac{n+1}{n})^2 \tan^2 \phi)}}$, $v_{2y} = v_{2x} \frac{n+1}{n} \tan \phi$,

$v_{1x} = -\frac{v_{2x}}{n}$, $v_{1y} = 0$, where 2 refers to the top wedge and 1 refers to the lower wedge.

11.56a) $\vec{F} = m(g + a_0) \left[\frac{\sqrt{3}}{4} \hat{i} + \frac{3}{4} \hat{j} \right].$

b) For $a_0 = -g$, the acceleration of the mass is exactly vertical; d_0 , v_0 , and t could be anything.

11.57a) angular speed = 8.8 rad/s.

b) displacement = 0.5 ft.

11.68a) For point mass: $\ddot{\phi} = (g/L) \sin \phi - (a_{hand}/L) \cos \phi.$

b) There are many correct solutions. Test your solution with a computer simulation. Show your result with appropriate plots.

11.69e) $\ddot{\phi} - \left[\frac{\ddot{y}+g}{L} \right] \sin \phi = 0$, where $y(t)$ is the vertical displacement of your hand and $\phi(t)$ is the angle of the broom from the vertical.

11.70) $\ddot{\phi}_1 = 0$, $\ddot{\phi}_2 = -3g/2\ell$.

11.71a) $\ddot{\phi} + \left[3(R - \frac{L}{2}) \frac{g}{L^2} \right] \phi = 0$.

b) This first-order approximation show that stable standing requires $R > \frac{L}{2}$. $R = \frac{L}{2}$ is neutrally stable (like a wheel).

12.7i) $-(\cos \theta \hat{i} + \sin \theta \hat{j})$.

12.10) Net force: $\vec{F} = m(-\omega a_0^2 L) \hat{j}$, Net moment:

$$\vec{M}_{/G} = \frac{1}{2}mr^2(-\omega_0\omega_1\hat{i} + \omega_0\omega_2\hat{j} - \omega_1\omega_2\hat{k}).$$

12.11) $\vec{a}_P = 0.732g\hat{k}$.

12.12a) $\vec{\omega}_{car} = \frac{v_o}{R}\hat{k}$.

b) $\vec{\omega}_{tire/car} = -\frac{v_o}{r}\hat{e}_r$, where \hat{e}_r is parallel to the axle of the wheel and moves with the car and k is perpendicular to the ground.

c) $\vec{\omega}_{tire} = \frac{v_o}{R}\hat{k} - \frac{v_o}{r}\hat{e}_r$.

d) total torque, $\vec{M} = \vec{0}$.

e) $\vec{M} = \vec{0}$.

f) $\vec{H}_{cm} = \frac{mv_or^2}{4} \left[-\frac{2}{r}\hat{e}_r + \frac{1}{R}\hat{k} \right]$.

g) $\dot{\vec{H}}_{cm} = \dot{\vec{H}}_{cm} = -\frac{mv_o^2r}{2R}\hat{e}_t$.

h) $\sum \vec{M}_{cm} = -\frac{mv_o^2r}{2R}\hat{e}_t$.

i) $\vec{a}_{bug} = -\frac{v_o^2}{R}\hat{e}_r + \frac{v_ov_g}{r}\hat{e}_t$, $\vec{F}_{bug} = m_{bug}\vec{a}_{bug}$.

12.14a) $\vec{a}_G = \frac{F}{m}\hat{k}$.

b) $\dot{\vec{\omega}} = \frac{3F}{mL}(\hat{i} - \hat{j})$.

c) $\vec{a}_B = \frac{4F}{m}\hat{k}$.

12.15a) $\vec{a}_B = \frac{4F}{m}\hat{k}$.

b) $\dot{\vec{\omega}} = (96\hat{i} + 48\hat{j}) \text{ rad/s}^2$

12.26a) $\vec{\omega}_{D/\mathcal{F}} = \Omega\hat{k} + \omega\hat{j}$.

b) $\vec{\alpha}_{D/\mathcal{F}} = -\Omega\omega\hat{i}$.

c) $\vec{v}_B = \Omega R\hat{j} + \frac{1}{2}\omega D\hat{i}$.

d) $\vec{a}_B = -\Omega^2 R\hat{i} + \Omega\omega D\hat{j} - \frac{1}{2}\omega^2 D\hat{k}$.

12.27) $\vec{\omega}_{D/\mathcal{F}} = \omega_2\hat{i} + \omega_1\hat{j} + \omega_0\hat{k}$.

12.30a) $\vec{v}_B = -\frac{\omega_1 h^2}{\sqrt{h^2+r^2}}\hat{k}$.

b) $\vec{\alpha}_{C/\mathcal{F}} = -\frac{\omega_1\omega_2}{\sqrt{1+(\frac{r}{h})^2}}\hat{k}$.

c) $\omega_1 = \frac{\omega_2}{\sqrt{h^2+r^2}}$.

d) $|\vec{\alpha}_{C/\mathcal{F}}| = \frac{v^2}{hr} \left(1 + \left(\frac{r}{h} \right)^2 \right)$.

12.33) $\dot{\vec{\omega}}_{D} = -\omega_0\omega_1\hat{i} + \omega_0\omega_2\hat{j} - \omega_1\omega_2\hat{k}$.

12.36b) $\vec{a}_P = -(\ell\dot{\Omega} + 2r\Omega\omega_s)\hat{i} + (2r\Omega\omega_c - \ell\Omega^2)\hat{j} - r(\omega_c^2 + \omega_s^2)\hat{k}$.

12.38a) $\vec{H}_{/G} = \frac{1}{2}mr^2\omega_2\hat{i} + \frac{1}{4}mr^2\omega_1\hat{j} + m\omega_0(L^2 + \frac{1}{4}r^2)\hat{k}$,
 $\dot{\vec{H}}_{/G} = \frac{1}{2}mr^2(-\omega_0\omega_1\hat{i} + \omega_0\omega_2\hat{j} - \omega_1\omega_2\hat{k})$.

b) $\vec{H}_{/E} = \frac{1}{2}mr^2\omega_2\hat{i} + \frac{1}{4}mr^2\omega_1\hat{j} + \frac{1}{4}mr^2\omega_0\hat{k}$, $\dot{\vec{H}}_{/E} = \dot{\vec{H}}_{/G} = \frac{1}{2}mr^2(-\omega_0\omega_1\hat{i} + \omega_0\omega_2\hat{j} - \omega_1\omega_2\hat{k})$.

12.39) $A_y = -3.16 \text{ N}$, $B_y = 3.16 \text{ N}$, $A_z = B_z = -63.16 \text{ N}$

12.48) $\vec{\omega}_{D} = 2\pi(2\hat{i} + \hat{j}) \text{ rad/s}$ and $\vec{\alpha}_{D} = 8\pi^2\hat{k} \text{ rad/s}^2$

12.50a) $\vec{\omega}_{D} = (2\hat{i} + 4\pi\hat{k}) \text{ rad/s}$

b) $\vec{\alpha}_{D} = -8\pi \text{ rad/s}^2 \hat{j}$

c) $\vec{M} = -\frac{\pi}{2} \text{ N}\cdot\text{m} \hat{j}$

d) $\vec{R}_A = \frac{\pi}{2} \text{ N}\hat{i}$, $\vec{R}_B = -\vec{R}_A$

12.52) $\vec{N} = \frac{\omega^2 m R}{2} \hat{k}$