

Fixed and Floating Fastener Variation

Chris Cuba
Raytheon Systems Company
McKinney, Texas

Chris Cuba began his career at Texas Instruments in 1984 and has been a key contributor on several defense programs as a systems producibility engineer. During this time, he has developed expertise in mechanical assembly producibility, mechanical tolerancing, and product design-to-cost. He was software development manager and applications engineer for the mechanical tolerancing tool CE/TOL. Mr. Cuba currently works as a member of the Mechanical Tolerancing and Performance Sigma Team at Raytheon Systems Company. As a Six Sigma Black Belt, his responsibilities include dimensional management consulting, Six Sigma mechanical tolerance analysis and allocation, and mechanical tolerancing training. He graduated from Oklahoma State University with a bachelor's degree in mechanical design.

23.1 Introduction

This chapter describes an approach to understanding the inherent assembly shift and manufacturing variation contributors within a fastened interface. In most cases, the fastened interface must meet two requirements: The parts must fit together and provide minimal assembly variation, and the variation allowed from the fastened interface should relate to a product performance requirement.

In this chapter, each variable of the fastened interface is broken down to understand its contribution to the total assembly variation.

- First, the chapter shows a worst case tolerance study on features of size that are located using a position feature control frame to understand the virtual and resultant condition boundaries.
- Next, features of size are used in an assembly to understand variation within a fixed and floating fastener.

23.2 Hole Variation

Fig. 23-1 shows an example dimensioned using a position feature control frame to locate the hole. The feature control frame locates the hole using the maximum material condition (MMC) modifier. When using the MMC modifier, tolerance may be added to the location tolerance as the actual feature size departs from MMC. Thus, the feature’s size tolerance and location tolerance are dependent. This dependency must be taken into account in the tolerance study.

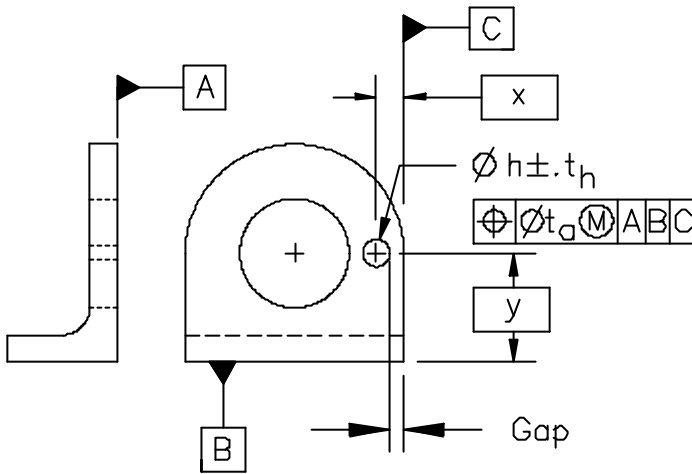

Figure 23-1 Feature located using positional tolerance at MMC

To analyze the tolerance, first calculate the worst case boundaries generated by the size and location tolerances of the hole. These boundaries define the virtual and resultant conditions of the hole.

The virtual condition is “a constant boundary generated by the collective effects of a size feature’s specified MMC or LMC material condition and the geometric tolerance for that material condition” (Reference 2).

$$\text{Virtual Condition Hole} = \text{Feature MMC Size} - \text{Position Tolerance at MMC}$$

For the example in Fig. 23-1, the virtual condition of the hole (*VCH*) is:

$$VCH = h - t_h - t_a$$

where

$$\text{hole feature MMC size} = h - t_h$$

$$\text{position tolerance at MMC} = t_a$$

The resultant condition is “the variable boundary generated by the collective effects of a size feature’s specified MMC or LMC material condition, the geometric tolerance for that material condition, the size tolerance, and the additional geometric tolerance derived from the feature’s departure from its specified material condition” (Reference 2).

$$\text{Resultant Condition Hole} = \text{Feature LMC Size} + \text{Position Tolerance at LMC}$$

For the example in Fig. 23-1, the resultant condition of the hole (*RCH*) is:

$$RCH = h + t_h + 2t_h + t_a$$

$$RCH = h + 3t_h + t_a$$

where

hole feature LMC size = $h + t_h$
 position tolerance at LMC = $2t_h + t_a$

To calculate the gap, the inner and outer boundaries (virtual and resultant condition) of the feature are converted to a radial value, with an equal bilateral tolerance ($r +/- t$). See Chapter 9.

$$r = (VCH + RCH)/4$$

$$r = [(h - t_h - t_a) + (h + 3t_h + t_a)]/4$$

$$r = (h + t_h)/2$$

where

r = mean radial conversion of virtual and resultant condition boundaries

and

$$t = (RCH - VCH)/4$$

$$t = [(h + 3t_h + t_a) - (h - t_h - t_a)]/4$$

$$t = t_h + .5t_a$$

where

t = equal bilateral tolerance of r

The radial value used in the dimension loop diagram is:

$$r +/- t$$

Substituting into these equations, we get:

$$r = .5(h + t_h) +/- (t_h + .5t_a)$$

which equals:

LMC/2 +/- (size tolerance + 1/2 feature control frame tolerance)

Fig. 23-2 shows the dimension loop diagram for the gap in Fig. 23-1.

The gap equation equals: $Gap = [x - .5(h + t_h)] +/- (t_h + .5t_a)$

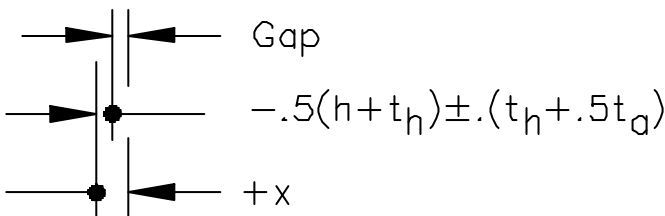

Figure 23-2 Dimension loop diagram for Fig. 23-1

23.3 Assembly Variation

The previous discussion developed an understanding for an individual feature's boundaries. These boundaries define the amount of assembly shift within a fastened interface. Assembly shift results from the amount of allowance defined between the fastener and clearance hole. Many engineers design the allowance amount using the fixed or floating fastener rules within ASME Y 14.5 (Reference 2). Zero assembly shift occurs when a virtual condition pin assembles into a virtual condition hole. Maximum assembly shift occurs when the pin and hole have perfect form and orientation at LMC size.

In most cases, the fastened interface must meet two requirements: The parts must fit together and provide minimal assembly variation. The assembly variation within the pin/hole interface can be analyzed several ways.

- The mating parts can be shifted until touching provides a maximum and minimum assembly variation. (See Figs. 23-3 and 23-4.)
- The assembly variation can be represented by a process capability. This could be in the form of a uniform, normal, or other known distribution.
- Tooling, fixtures, or gravity can be used to minimize or eliminate assembly variation.

This chapter looks at shifting the mating parts to understand the maximum and minimum assembly variation.

23.4 Fixed and Floating Fasteners

There are two types of fastening systems used to assemble parts: fixed fasteners and floating fasteners. Fig. 23-3 illustrates a fixed fastener. This is defined as a fastener where one of the parts has restrained fasteners such as screws in tapped holes or studs (Reference 2). A floating fastener is defined as a fastener where two or more parts are assembled with fasteners such as bolts and nuts, and all parts have clearance holes for the bolts (Reference 2). See Chapter 22 for more discussion on fixed and floating fasteners.

The assembly variation within a fixed fastener occurs when one part shifts as shown in Fig. 23-3. The floating fastener assembly variation has two parts shifting that contribute to the variation as shown in Fig. 23-4.

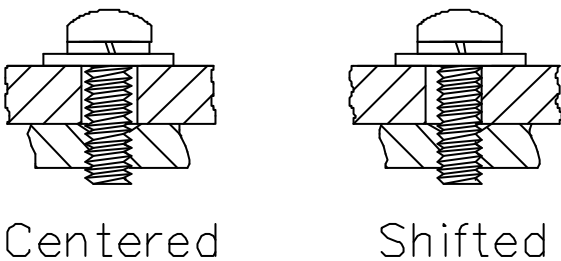

Figure 23-3 Fixed fastener centered and shifted

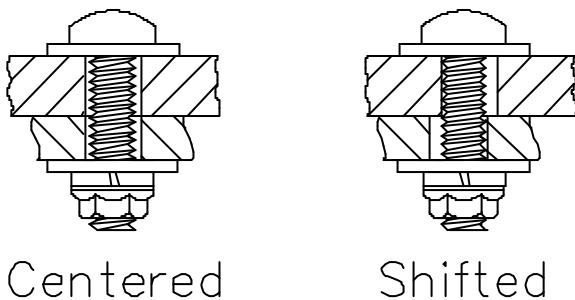

Figure 23-4 Floating fastener centered and shifted

23.4.1 Fixed Fastener Assembly Shift

Fig. 23-5 shows a fixed fastener within an assembly and uses the following notation to develop equations for assembly shift, minimum gap, and maximum gap. The minimum and maximum gaps between datum surfaces E and B occur when the locating features are at least material condition and using their maximum location tolerances. The following summarizes these conditions.

<u>Feature</u>	<u>LMC Size</u>	<u>Location Tolerance at LMC</u>
Hole	$h + t_h$	$t_a + 2t_h$
Pin	$p - t_p$	$t_b + 2t_p$

where

- p = Pin mean size
- t_p = Equal bilateral pin size tolerance
- t_a = Cylindrical tolerance zone diameter (hole)
- h = Hole mean size
- t_h = Equal bilateral hole size tolerance
- t_b = Cylindrical tolerance zone diameter (pin)

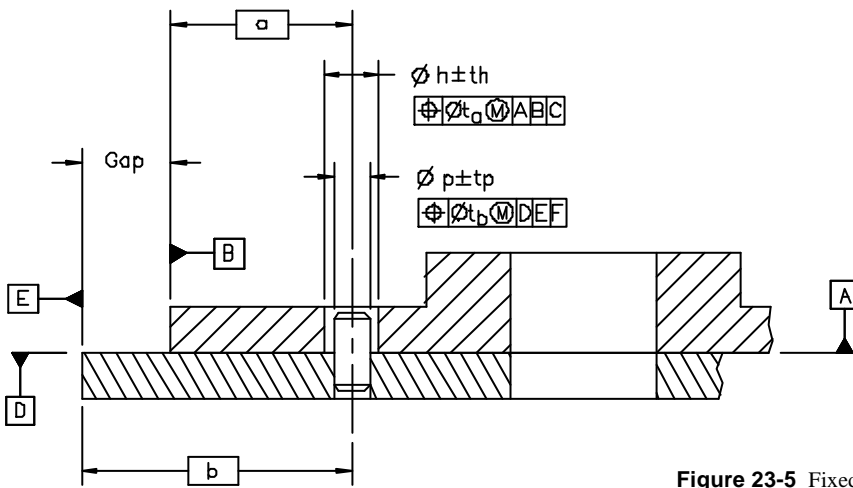

Figure 23-5 Fixed fastener assembly

Shifting the parts to a maximum and minimum shows the worst case gap for each condition. Conventionally, we draw a dimension loop diagram for each condition. Fig. 23-6 shows the two parts shifted for a minimum assembly gap and the resultant dimension loop diagram.

Minimum Gap = Nominal Gap - Tolerance

$$\text{Minimum Gap} = [b + .5(p - t_p) - .5(h + t_h) - a] - [(.5t_a + t_h) + (.5t_b + t_p)]$$

which simplifies to:

$$\text{Minimum Gap} = (b - a) - .5(h - p) - .5(t_a + t_b) - 1.5(t_h + t_p) \tag{23.1}$$

Note that Eq. (23.1) gives the minimum gap if the parts touch as shown in Fig. 23-6. Since the minimum gap occurs when the pin and hole are both at LMC, the parts may be manually shifted to increase this gap. The amount the parts can shift is $(h + t_h) - (p - t_p)$.

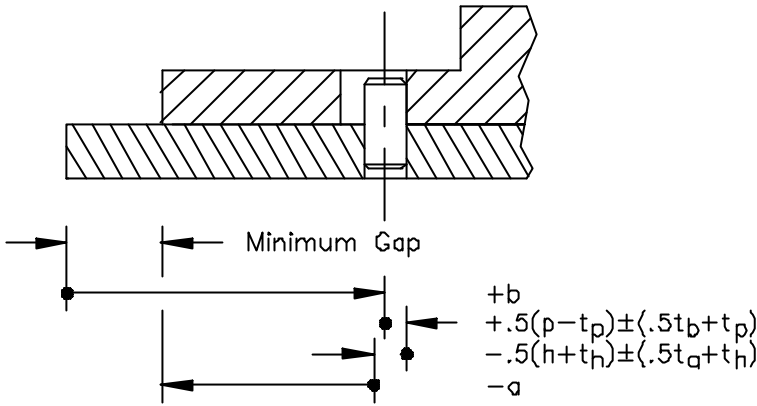

Figure 23-6 Fixed fastener minimum assembly gap

Fig. 23-7 shows the two parts shifted to a maximum assembly gap and the resultant dimension loop diagram.

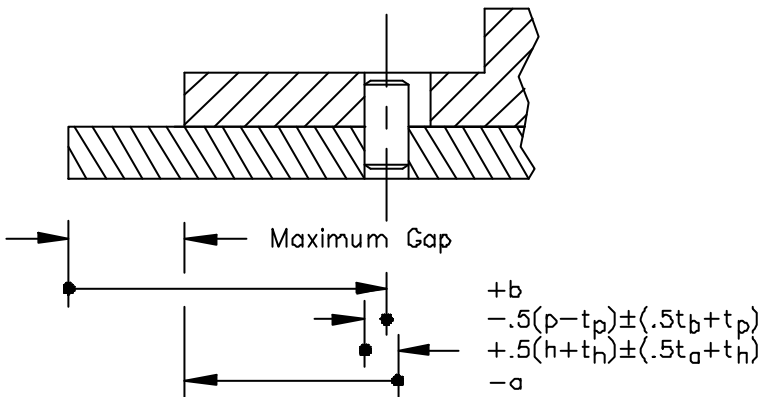

Figure 23-7 Fixed fastener maximum assembly gap

Maximum Gap = Nominal Gap + Tolerance

$$\text{Maximum Gap} = [b - .5(p - t_p) + .5(h + t_h) - a] + [(.5t_a + t_h) + (.5t_b + t_p)]$$

which simplifies to:

$$\text{Maximum Gap} = (b - a) + .5(h - p) + 1.5(t_h + t_p) + .5(t_a + t_b) \tag{23.2}$$

Note that Eq. (23.2) gives the maximum gap if the parts touch as shown in Fig. 23-7. Since the maximum gap occurs when the pin and hole are both at LMC, the parts may be manually shifted to decrease this gap. The amount the parts can shift is $(h + t_h) - (p - t_p)$.

23.4.2 Fixed Fastener Assembly Shift Using One Equation and Dimension Loop

The following discussion describes an alternative method of defining two dimension loop diagrams and equations for the assembly variation at the gap. This method defines one equation for the total variation at the gap.

A radial plus and minus value can express the assembly shift in the fixed fastener example. This value is the maximum diametrical amount of clearance between the fixed pin or fastener, and the clearance hole divided by two. As the mating features depart from their respective virtual conditions, the assembly shift increases. The maximum assembly shift occurs when the pin and hole have perfect form and orientation at Least Material Condition (LMC).

From Fig. 23-5, the fixed fastener LMC assembly shift (AS_{fix}) is:

$$AS_{fix} = .5[h + t_h - (p - t_p)] \quad (23.3)$$

where

$h + t_h$ = Clearance hole LMC size

$p - t_p$ = Pin (fastener) LMC size

23.4.3 Fixed Fastener Equation

As previously stated, the most variation within a fastened interface occurs when the mating features are at LMC. This allows additional (bonus) tolerance to accumulate. From the fixed fastener example in Fig. 23-5 the additional (bonus) tolerance contributors are:

$2(t_h)$ = Clearance hole size tolerance

$2(t_p)$ = Total pin (fastener) size tolerance

Other contributors in the tolerance study are location tolerances for each feature. From Fig. 23-5, the location tolerance contributors are:

t_a = Cylindrical tolerance zone for the clearance hole

t_b = Cylindrical tolerance zone for the pin

The total tolerance variation (tv) at the gap is:

$$tv = 2t_h + 2t_p + t_a + t_b$$

The +/- or radial tolerance variation (rtv) at the gap is:

$$rtv = tv/2$$

$$rtv = t_h + t_p + .5t_a + .5t_b \quad (23.4)$$

Combining Eqs. (23.3) and (23.4) gives the gap variation (gv) with assembly shift included.

$$gv = AS_{fix} + rtv$$

$$gv = .5[h + t_h - (p - t_p)] + t_h + t_p + .5t_a + .5t_b$$

This reduces to:

$$gv = .5(h - p) + .5(t_a + t_b) + 1.5(t_h + t_p) \quad (23.5)$$

23.4.4 Fixed Fastener Gap Analysis Steps

Using Eq. (23.5), only one dimension loop diagram is needed to understand the minimum and maximum assembly gap. The diagram identifies the mean assembly dimension and Eq. (23.5) gives the variation from the mean.

First, construct the dimension loop diagram. The dimension loop diagram rules do not change when a fastener becomes part of the stackup. The diagram is drawn the same, except a vector is drawn to and from the centerline of the fastened interface, continuing until the right hand side of the gap is reached. The diagram *does not* trace the pin and hole as if one part was shifted relative to the other.

The dimension loop diagram for Fig. 23-5 is shown in Fig. 23-8.

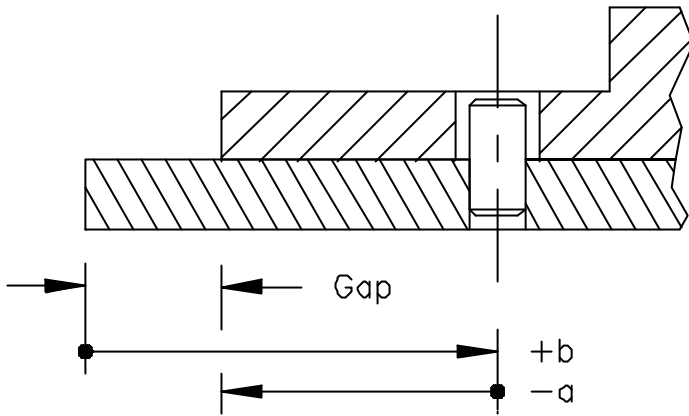

Figure 23-8 Centered fixed fastener dimension loop diagram

The Gap equation is: $Gap = (b - a) \pm gv$

This equals: $Gap = (b - a) \pm .5(t_a + t_b) + .5(h - p) + 1.5(t_h + t_p)$

This gives the same minimum and maximum gap in Eqs. (23.1) and (23.2).

23.4.5 Floating Fastener Gap Analysis Steps

We can construct the floating fastener dimension loop diagram in the same manner as the fixed fastener example. In the floating fastener application (Fig. 23-9), the assembly shift calculation uses the two clearance holes and fastener. In this case, the fastener shifts within both clearance holes.

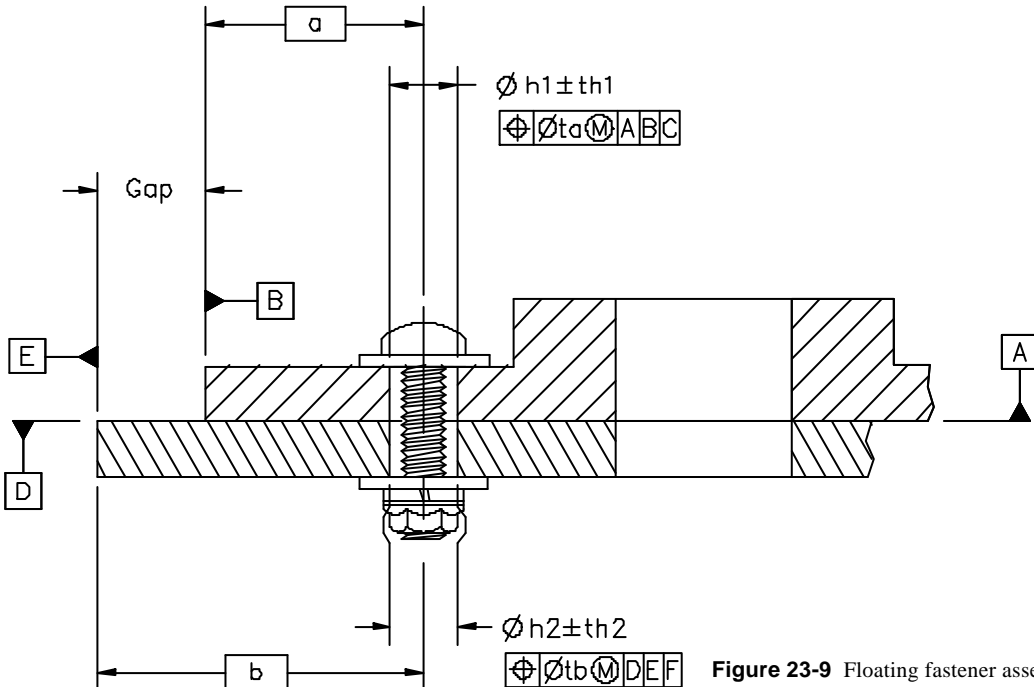

Figure 23-9 Floating fastener assembly

As previously stated, the most variation within a fastened interface occurs when the mating features are at LMC. This allows additional (bonus) tolerance to accumulate. From Fig. 23-9 the equation for assembly shift at LMC is:

$$AS_{float} = .5(h_1 + t_{h1} + h_2 + t_{h2}) - (p - t_p) \quad (23.6)$$

where

- h_1 = Mean clearance hole 1 size
- t_{h1} = Equal bilateral clearance hole 1 size tolerance
- h_2 = Mean clearance hole 2 size
- t_{h2} = Equal bilateral clearance hole 2 size tolerance
- p = Mean pin (fastener) size
- t_p = Equal bilateral pin (fastener) size tolerance

From Fig. 23-9, the additional (bonus) tolerance contributors are:

- $2(t_{h1})$ = Clearance hole 1 size tolerance
- $2(t_{h2})$ = Clearance hole 2 size tolerance

Other contributors in the tolerance study are location tolerances for each feature. The location tolerance contributors are:

- t_a = Cylindrical tolerance zone for clearance hole 1
- t_b = Cylindrical tolerance zone for clearance hole 2

The total tolerance variation (tv) at the gap is:

$$tv = 2t_{h1} + 2t_{h2} + t_a + t_b$$

The +/- or radial tolerance variation (tvr) at the gap is:

$$\begin{aligned} tvr &= tv/2 \\ tvr &= t_{h1} + t_{h2} + .5t_a + .5t_b \end{aligned} \quad (23.7)$$

Combining Eqs. (23.6) and (23.7) gives the gap variation (gv) with assembly shift included.

$$\begin{aligned} gv_{float} &= AS_{float} + tv \\ gv_{float} &= (h_1 + t_{h1} + h_2 + t_{h2})/2 - (p - t_p) + t_{h1} + t_{h2} + .5t_a + .5t_b \end{aligned}$$

This reduces to:

$$gv_{float} = .5(t_a + t_b) + 1.5(t_{h1} + t_{h2}) + .5(h_1 + h_2) - (p - t_p)$$

The gap equation is:

$$\begin{aligned} Gap &= (b - a) +/- gv_{float} \\ Gap &= (b - a) +/- .5(t_a + t_b) + 1.5(t_{h1} + t_{h2}) + .5(h_1 + h_2) - (p - t_p) \end{aligned}$$

23.5 Summary

This chapter demonstrates a process to perform worst case tolerance analysis on fixed and floating fasteners. The methodology described extends the conventional tolerance analysis methodology by introducing the concepts of virtual and resultant condition. This methodology can be used on any feature having dependent size and location tolerance. The concepts are further used to develop one equation to find minimum and maximum assembly conditions by understanding assembly shift within a fastened interface. Maximum assembly shift occurs when both features of the fastened interface are at least material condition. Although the fixed and floating fastener rules ensure a worst case fit, they also allow a part

23-10 Chapter Twenty-three

position to float when worst case conditions are not present. Many designs minimize or eliminate assembly shift by using tooling or assembly instruction to “shift out” the variation.

23.6 References

1. Cuba, Chris and Paul Drake. 1992. Mechanical Tolerance Analysis of Fixed and Floating Fasteners. *Texas Instruments Technical Journal*. Nov-Dec: 58-65.
2. The American Society of Mechanical Engineers. 1995. *ASME Y14.5M-1994, Dimensioning and Tolerancing*. New York, New York: The American Society of Mechanical Engineers.