

**P • A • R • T • 5**

# **GAGING**

## Paper Gage Techniques

**Martin P. Wright**  
**Behr Climate Systems, Inc.**  
**Fort Worth, Texas**

*Martin P. Wright is supervisor of Configuration Management for Behr Climate Systems, Inc. in Fort Worth, Texas, where he directs activities related to dimensional management consulting and company training programs. He has more than 20 years of experience utilizing the American National Standard on Dimensioning and Tolerancing and serves as a full-time, on-site consultant assisting employees with geometric tolerancing applications and related issues. Mr. Wright has developed several multilevel geometric tolerancing training programs for several major companies, authoring workbooks, study guides, and related class materials. He has instructed more than 4,500 individuals in geometric tolerancing since 1988.*

*Mr. Wright is currently an active member and Working Group leader for ASME Y14.5, which develops the content for the American National Standard on dimensioning and tolerancing. He also serves as a member of the US Technical Advisory Group (TAG) to ISO TC213 devoted to dimensioning, tolerancing, and mathematization practices for international standards (ISO). In addition to these standards development activities, Mr. Wright serves as a member and/or officer on six other technical standard subcommittees sponsored by the American Society of Mechanical Engineers (ASME).*

### **18.1 What Is Paper Gaging?**

Geometric Dimensioning and Tolerancing (GD&T) as defined by ASME Y14.5M-1994 provides many unique and beneficial concepts in defining part tolerances. The GD&T System allows the designer to specify round, three-dimensional (3-D) tolerance zones for locating round, 3-D features (such as with a pattern of holes). The system also offers expanded concepts, such as the maximum material condition (MMC) principle, that allows additional location tolerance based on the produced size of the feature.

(See Chapter 5.) These concepts work well in assuring that part features will function as required by the needs of the design, while maximizing all available production tolerances for the individual workpiece. Although these tolerancing concepts are beneficial for both design and manufacturing, their use can pose some unique problems for the inspector who must verify the requirements.

It is widely recognized that, in terms of inspection, the optimum means for verifying part conformance to geometric tolerancing requirements is through the use of a fixed-limit gage. (See Chapter 19.) This gage is essentially the physical embodiment of a 3-D, worst case condition of the mating part. If the part fits into the functional gage, the inspector may also be assured that it will assemble and interchange with its mating part. Since the gaging elements are fixed in size, the additional location tolerance allowed for a larger produced hole (or the dynamic “shift” of a datum feature subject to size variation) is readily captured by the functional gage. Additionally, functional gages are easily used by personnel with minimal inspection skills and they can significantly reduce overall inspection time. However, there are drawbacks to using functional gages. They are expensive to design, build, and maintain, and they require that a portion of the product tolerance be sacrificed (usually about 10%) to provide tolerance for producing the gage itself. For these reasons, use of functional gages is generally limited to cases where a large quantity of parts are to be verified and the reduced inspection time will offset the cost of producing the gage.

Verification of geometric tolerances for the vast majority of produced parts is accomplished through the use of data collected either manually in a layout inspection, or electronically using a Coordinate Measuring Machine (CMM). Either method requires the inspector to lock the workpiece into a frame of reference as prescribed by the engineering drawing and take actual measurements of the produced features. The inspector must then determine “X” and “Y” coordinate deviations for the produced features by comparing the actual measured values to the basic values as indicated on the drawing. Typically, these coordinate deviations are used in determining positional tolerance error for the produced feature through one of two methods: mathematical conversion of the coordinate deviations or by use of a paper gage.

Paper gaging is one of several common inspection verification techniques that may be used to ensure produced feature conformance to an engineering drawing requirement. This technique, also referred to as Soft Gaging, Layout Gaging, or Graphical Inspection Analysis, provides geometric verification through a graphical representation and manipulation of the collected inspection data. Cartesian coordinate deviations derived from the measurement process are plotted on to a coordinate grid, providing a graphical “picture” of the produced feature locations in relation to their theoretically “true” location.

Modern tolerancing methods as defined throughout ASME Y14.5M-1994 prescribe that round features, such as holes, be located within round tolerance zones. However, most dimensional inspection techniques measure parts in relation to a square, Cartesian coordinate system. Paper gaging provides a convenient and accurate method for converting these measured values into the round, polar coordinate values required in a positional tolerance verification. This is accomplished graphically by superimposing a series of rings over the coordinate grid that represents the positional tolerance zones.

## **18.2 Advantages and Disadvantages to Paper Gaging**

Since the optimum means for a geometric tolerancing requirement is through the use of a fixed-limit gage, the primary advantage provided by paper gaging lies in its ability to verify tolerance limits similar to those of a hard gage. Paper gaging techniques graphically represent the functional acceptance boundaries for the feature, without the high costs of design, manufacture, maintenance, and storage required for a fixed-limit gage. Additionally, paper gaging does not require that any portion of the product tolerance be sacrificed for gage tolerance or wear allowance.

Paper gaging is also extremely useful in capturing dynamic tolerances found in datum features subject to size variation or feature-to-feature relationships within a pattern of holes. Neither of these can be

effectively captured in a typical layout inspection. The ability to manipulate the polar coordinate overlay used in the paper gage technique gives the inspector a way to duplicate these unique tolerance effects.

Since it provides a visual record of the actual produced features, paper gaging can be an extremely effective tool for evaluating process trends and identifying problems. Unlike a hard gage, which simply verifies GO/NO-GO attributes of the workpiece, the paper gage can provide the operator with a clear illustration of production problems and the precise adjustment necessary to bring the process back into control. Factors such as tooling wear and misalignment can readily be detected during production through periodic paper gaging of verified parts. Additionally, paper gages can be easily stored using minimal, low-cost space.

The primary drawback to paper gage method of verification is that it is much more labor-intensive than use of a fixed-limit gage. Paper gaging requires a skilled inspector to extract actual measurements from the workpiece, then translate this data to the paper gage. For this reason, paper gaging is usually considered only when the quantity of parts to be verified is small, or when parts are to be verified only as a random sampling.

### 18.3 Discrimination Provided By a Paper Gage

With paper gaging, the coordinate grid and polar overlay are developed proportionately relative to one another and do not necessarily represent a specific measured value. Because they are generic in nature, the technique may be used with virtually any measurement discrimination. The spacing between the lines of the coordinate grid may represent .1 inch for verification of one part, and .0001 inch for another.

A typical inspection shop may only need to develop and maintain three or four paper gage masters. Each master set would represent a maximum tolerance range capability for that particular paper gage. The difference between them would be the number of grid lines per inch used for the coordinate grid. More grid lines per inch on the coordinate grid allow a wider range of tolerance to be effectively verified by the paper gage. However, an increase in the range of the paper gage lowers the overall accuracy of the plotted data. The inspector should always select an appropriate grid spacing that best represents the range of tolerance being verified.

### 18.4 Paper Gage Accuracy

A certain amount of error is inherent in any measurement method, and paper gages are no exception. The overall accuracy of a paper gage may be affected by factors such as error in the layout of the lines that make up the graphs, coefficient of expansion of the material used for the graphs or overlays, and the reliability of the inspection data. Most papers tend to expand with an increase in the humidity levels and, therefore, make a poor selection for grid layouts where fine precision is required. Where improved accuracy is required, Mylar is usually the material of choice since it remains relatively stable under normal changes in temperature and humidity.

By amplifying (enlarging) the grid scale, we can reduce the effects of layout error in the paper gage. Most grid layout methods will provide approximately a .010 inch error in the positioning of grid lines. From this, the apparent error provided by the grid as a result of the line positioning error of the layout may be calculated as follows:

$$\frac{\text{Line Position Error}}{\text{Scale Factor}} = \text{Apparent Layout Error}$$

For example, if a 10×10 to-the-inch grid is selected, with each line of the grid representing .001, a scale factor of 100-to-1 is provided, resulting in an apparent layout error for the grid of .0001 inch. However, if a

5 × 5 to-the-inch grid is selected, with each line of the grid representing .001, a scale factor of 200-to-1 is provided, resulting in an apparent layout error for the grid of only .00005 inch.

### 18.5 Plotting Paper Gage Data Points

It is extremely important for all users to plot data points on the coordinate grid of a paper gage in the same manner. This is a mandatory requirement in order to maintain consistency and to provide an accurate representation of the produced part. Inadvertently switching the X and Y values, or plotting the points in the wrong direction (plus or minus) will result in an inaccurate picture of the produced part features. This renders the paper gage useless as an effective process analysis tool.

On the engineering drawing, each hole or feature has a basic or “true” location specified. If the hole or feature were located perfectly, the measured value and the basic value would be the same. It could therefore be stated that the theoretical address of the hole or feature at true position is X=0, Y=0. Since geometric location tolerances are only concerned with the deviation from true position, the center of the coordinate grid may be used to represent the theoretical address for each feature being verified.

The data points represent deviations from true position and should always be plotted on the coordinate grid based on the relationship to its theoretical address and in a manner consistent with the view in which the holes are specified. For example, when plotting the X deviation for a hole, the data point is considered to have a plus X value where the feature falls to the right of its theoretical address, and a minus X value where it falls to the left of its theoretical address. When plotting the Y deviation, the data point is considered to have a plus Y value where the feature falls above its theoretical address, and a minus Y value where it falls below the theoretical address. See Fig. 18-1. Consistently following this methodology for plotting the data points will assure the reliability of the paper gage for both tolerance evaluation and process analysis.

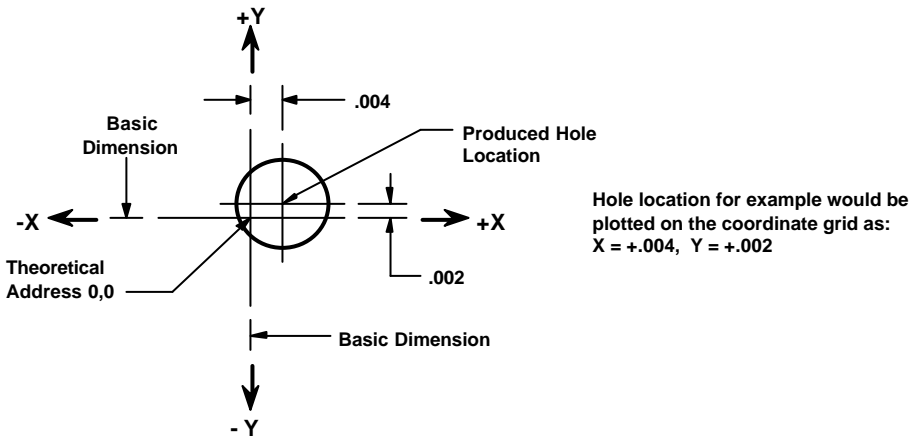

Figure 18-1 Directional indicators for data point plotting

### 18.6 Paper Gage Applications

The following examples illustrate some of the common applications for paper gages in evaluating part tolerances and analyzing process capabilities. Although these examples illustrate just a few of the many uses for a paper gage, they provide the reader with an excellent overview as to the effectiveness and versatility of this valuable manufacturing and inspection tool.

### 18.6.1 Locational Verification

Development of a functional gage to verify feature locations may not be practical or cost effective for many parts. For example, parts that will be produced in relatively small quantities, or parts that will fall under some type of process control where part verification will only be done on a random, periodic basis may not require production of a functional gage. For these parts, it may be more cost effective to verify the tolerances manually using data collected from a layout inspection. This data may then be transferred to a paper gage to verify the locational attributes of the features (similar to a fixed-limit gage) for only a fraction of the cost.

#### 18.6.1.1 Simple Hole Pattern Verification

The following example illustrates how the paper gage may be used to verify the locational requirement of the hole pattern for the part shown in Fig. 18-2. The drawing states that the axis of each hole must lie within a  $\text{Ø}0.010$  tolerance zone when produced at their maximum material condition size limit of  $\text{Ø}0.309$ . Since an MMC modifier has been specified, additional locational tolerance is allowed for the holes as they depart their MMC size limit (get larger) by an amount equal to the departure.

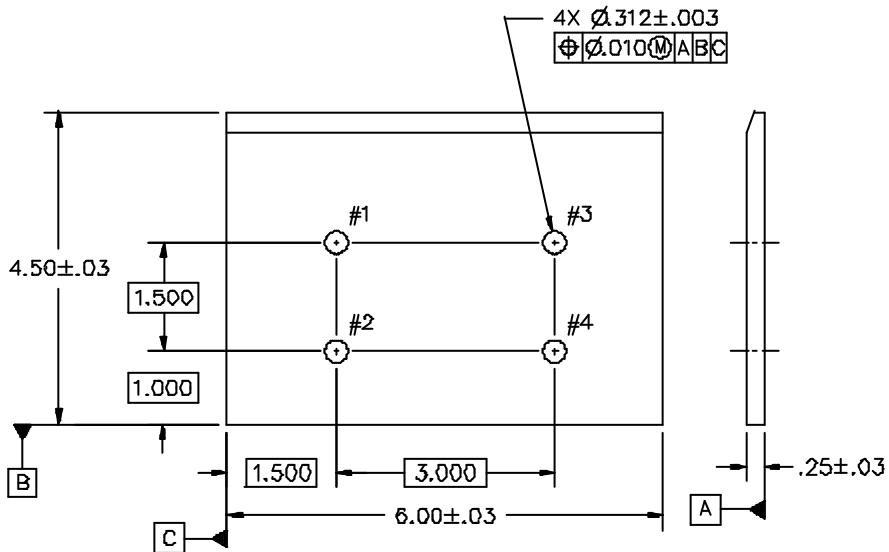

Figure 18-2 Example four-hole part

A layout inspection requires that the inspector collect actual measurements from the produced part and compare these with the tolerances indicated by the engineering drawing. The actual measurement data may be obtained electronically using a CMM or manually using a surface table and angle plate setup. The data collected from a layout inspection provides actual “X” and “Y” values for the location of features in relation to the measurement origin. That is, the measurement provided is always in relation to a Cartesian Coordinate frame of reference.

In evaluating the locational requirements for the hole pattern, the inspector must first verify that all holes fall within their acceptable limits of size. The inspector must also know the produced size of each hole in order to determine the amount of positional tolerance allowed for each hole. To determine the produced hole size, the inspector inserts the largest gage pin possible into each of the holes. This effectively defines the actual mating size of the hole, allowing the inspector to calculate the amount of

additional positional tolerance (bonus tolerance) allowed for location. The difference between the actual mating size and the specified MMC size is the allowed bonus tolerance. This tolerance may be added to the tolerance value specified in the feature control frame.

Once it has been determined that the hole sizes are within acceptable limits, the inspector must set up the part to measure the hole locations. He accomplishes this by relating the datum features specified by the feature control frame to the measurement planes of the inspector's equipment (i.e., surface table, angle plate). The inspector **MUST** use the datum features in the same sequence as indicated by the feature control frame. The final setup for the sample part shown above may resemble the part illustrated in Fig. 18-3.

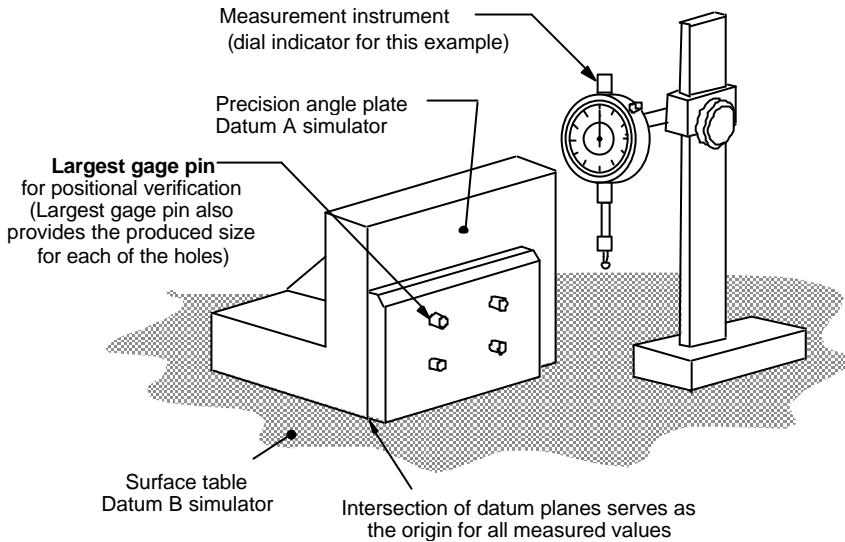

**Figure 18-3** Layout inspection of four-hole part

The pins placed in the holes aid the inspector when measuring the hole location. Actual “X” and “Y” measurements are made to the surface of the pin and as near to the part face as practicable. With the size of each pin known, adding 1/2 of the pin’s diameter to the measured value will provide the total actual measurement to the center of each hole.

Once the part is locked into the datum reference frame, measurements are made in an “X” and a “Y” direction and the data is recorded on the Inspection Report for final evaluation. This evaluation involves taking the coordinate data from the actual measurements and converting it into a round positional tolerance. Table 18-1 illustrates a sample Inspection Report that provides the data for paper gage evaluation of the hole pattern.

**Table 18-1** Layout Inspection Report of four-hole part

| LAYOUT INSPECTION REPORT |           |              |        |      |            |            |        |       |            |        |       |        |        |
|--------------------------|-----------|--------------|--------|------|------------|------------|--------|-------|------------|--------|-------|--------|--------|
| NO.                      | FEATURE   | FEATURE SIZE |        |      | ALLOW TOL. | X LOCATION |        |       | Y LOCATION |        |       | ACCEPT | REJECT |
|                          |           | MMC          | ACTUAL | DEV. |            | BASIC      | ACTUAL | DEV   | BASIC      | ACTUAL | DEV   |        |        |
| 1                        | .312±.003 | .309         | .311   | .002 | ∅.012      | 1.500      | 1.503  | +.003 | 2.500      | 2.501  | +.001 | X      |        |
| 2                        | .312±.003 | .309         | .313   | .004 | ∅.014      | 1.500      | 1.505  | +.005 | 1.000      | .998   | -.002 | X      |        |
| 3                        | .312±.003 | .309         | .312   | .003 | ∅.013      | 4.500      | .496   | -.004 | 2.500      | 2.497  | -.003 | X      |        |
| 4                        | .312±.003 | .309         | .310   | .001 | ∅.011      | 4.500      | .494   | -.006 | 1.000      | 1.002  | +.002 |        | X      |

Using the data from the Inspection Report, the information is then transferred to the paper gage by plotting each of the holes on a coordinate grid as shown in Fig. 18-4. The center of the grid represents the basic or true position (theoretical address 0,0) for each of the holes. Their actual location in relation to their theoretical address is plotted on the grid using the X and Y deviations from the Inspection Report.

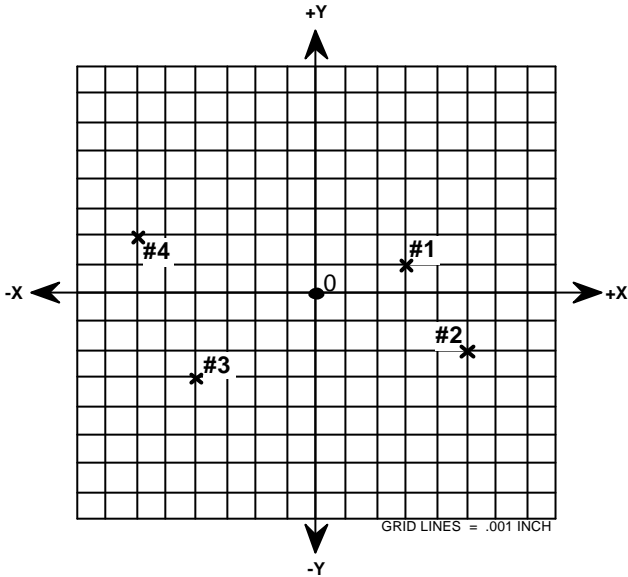

**Figure 18-4** Plotting the holes on the coordinate grid

Once the holes have been plotted onto the coordinate grid, a polar coordinate system (representing the round positional tolerance zones) is laid over the coordinate grid. See Fig. 18-5. The rings of the polar coordinate system represent the range of positional tolerance zones as allowed by the drawing specifica-

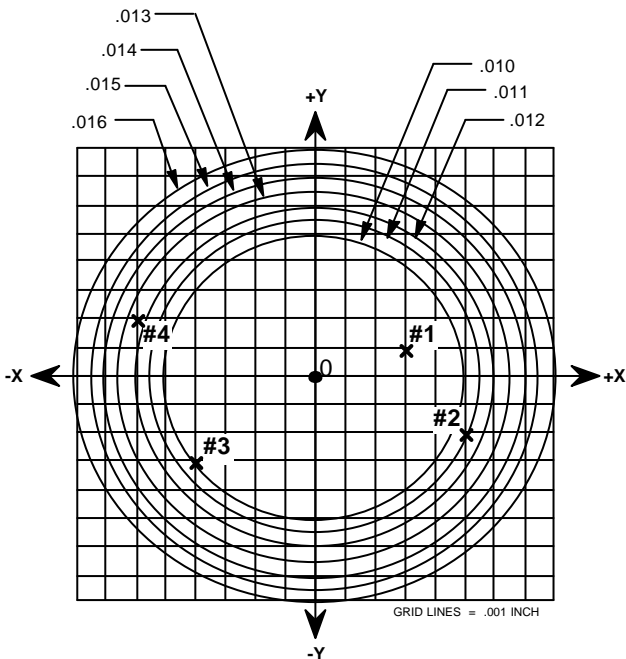

**Figure 18-5** Overlaying the polar coordinate system



tion;  $\varnothing.010$  positional tolerance allowed for a  $\varnothing.309$  hole, up to  $\varnothing.016$  allowed for a  $\varnothing.315$  hole. With the center of the polar coordinate system aligned with the center of the coordinate grid, the inspector then visually verifies that each plotted hole falls inside its allowable position tolerance. If all the holes fall inside their zones, the part is good and the inspector is done.

For the example, all of the holes fall inside their respective tolerance zones, with the exception of hole #4 which is required to be inside a  $\varnothing.011$  tolerance zone. However, the paper gage shows that the hole *does* fall inside a  $\varnothing.013$  ring. With the MMC concept, the hole may be enlarged by  $\varnothing.002$  to a size of  $\varnothing.312$ , which in turn increases the allowable positional tolerance to  $\varnothing.013$ . This brings the hole into compliance with the drawing specification.

### 18.6.1.2 Three-Dimensional Hole Pattern Verification

In the previous example, the holes were verified using a two-dimensional (2-D) analysis of the hole pattern using only measurements taken along the X and Y axes. This is a common practice used in reducing overall inspection time. By using only a 2-D analysis of the hole pattern, the inspector takes a calculated risk that the holes will remain relatively perpendicular based on known capabilities of the processes. Longer holes (usually 1/2-inch in length or longer) should be verified through a 3-D analysis of the hole pattern.

Fig. 18-6 illustrates the part used in the previous example except that the part thickness is greatly increased, making the length of the holes approximately 1-1/2 inches long. The part must be verified three-dimensionally to ensure that the entire length of the hole resides within the specified positional tolerance.

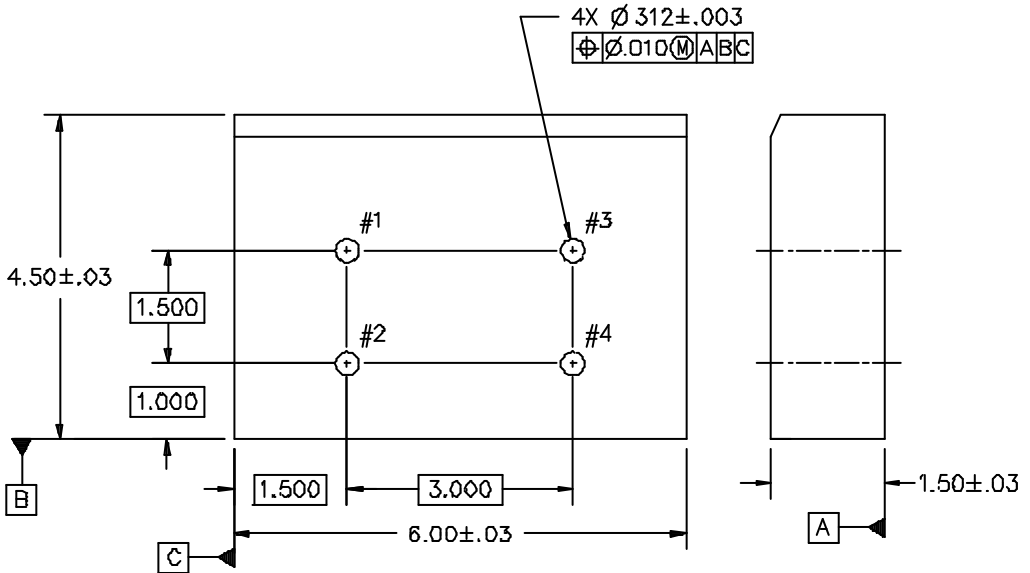

Figure 18-6 Example four-hole part with long holes

Setup and measurement of the workpiece is done in a manner similar to that used for the 2-D analysis except that the inspector must now collect two sets of measurements— one set for each end of the hole. Collecting data from each end of the hole allows the inspector to plot both ends of the hole axis on the coordinate grid of the paper gage: providing a 3-D rendering of the hole axis. Table 18-2 illustrates a sample Inspection Report used for a 3-D analysis of the hole pattern.

**Table 18-2** Inspection Report for part with long holes

| LAYOUT INSPECTION REPORT |               |              |        |      |            |            |        |        |            |        |        |        |        |
|--------------------------|---------------|--------------|--------|------|------------|------------|--------|--------|------------|--------|--------|--------|--------|
| NO.                      | FEATURE       | FEATURE SIZE |        |      | ALLOW TOL. | X LOCATION |        |        | Y LOCATION |        |        | ACCEPT | REJECT |
|                          |               | MMC          | ACTUAL | DEV. |            | BASIC      | ACTUAL | DEV    | BASIC      | ACTUAL | DEV    |        |        |
| 1                        | .312<br>±.003 | .309         | .312   | .003 | Ø.013      | 1.500      | 1.503  | + .003 | 2.500      | 2.501  | + .001 | X      |        |
|                          |               |              |        |      |            | 1.500      | 1.505  | + .005 | 2.500      | 2.498  | - .002 | X      |        |
| 2                        | .312<br>±.003 | .309         | .311   | .002 | Ø.012      | 1.500      | 1.496  | - .004 | 1.000      | .997   | - .003 | X      |        |
|                          |               |              |        |      |            | 1.500      | 1.494  | - .006 | 1.000      | 1.002  | + .002 |        | X      |
| 3                        | .312<br>±.003 | .309         | .313   | .004 | Ø.014      | 4.500      | 4.501  | + .001 | 2.500      | 2.502  | + .002 | X      |        |
|                          |               |              |        |      |            | 4.500      | 4.499  | - .001 | 2.500      | 2.506  | + .006 | X      |        |
| 4                        | .312<br>±.003 | .309         | .312   | .003 | Ø.013      | 4.500      | 4.504  | + .004 | 1.000      | 1.001  | + .001 | X      |        |
|                          |               |              |        |      |            | 4.500      | 4.507  | + .007 | 1.000      | 1.002  | + .002 |        | X      |

The Inspection Report reflects two sets of X and Y deviations for each hole, with each set representing the measured location of the hole axis. Both points are plotted on the coordinate grid and joined by a line to indicate that they represent the axis of a single hole. Fig. 18-7 illustrates the hole axes as they would appear after plotting on the coordinate grid.

As with the previous example, a polar coordinate system (representing the round positional tolerance zones) is laid over the coordinate grid as illustrated in Fig. 18-7 (right). With the center of the polar coordinate system aligned with the center of the coordinate grid, the inspector visually verifies that both ends of the hole axes reside inside its allowable position tolerance. This procedure creates the effect of a 3-D gage for the holes. For the example, both holes 2 and 4 would be rejected since one end of their axes lies outside the allowable tolerance zone.

When required, this technique also allows the individual perpendicularity for each hole to be easily measured. By circumscribing the smallest circle about the two points representing each hole axis, the actual perpendicularity for each individual hole can be derived. The actual perpendicularity must be less than, or equal to, the specified perpendicularity defined by the engineering drawing.

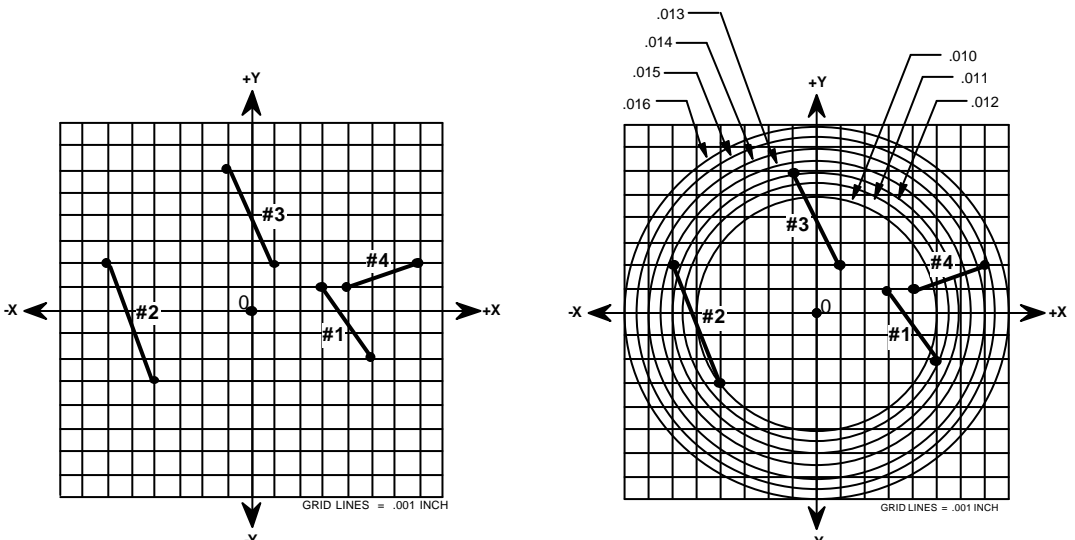

**Figure 18-7** Plotting 3-dimensional hole data on the coordinate grid



Verification of the upper segment is accomplished as in previous examples. A polar coordinate system (representing the round positional tolerance zones) is laid over the coordinate grid with the centers of both aligned as shown in Fig. 18-9. The inspector then visually verifies that each plotted hole falls inside its allowable position tolerance. If all the holes fall inside their zones, the part has passed the first requirement.

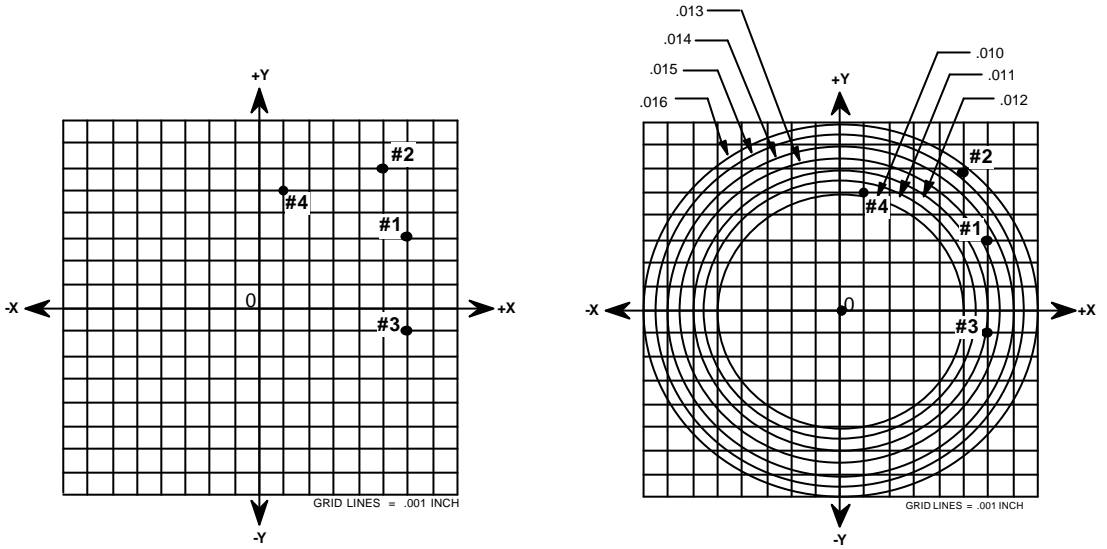

**Figure 18-9** Paper gage verification of hole pattern location

Verification of the lower segment requires that a second set of smaller rings be laid over the same coordinate grid verifying the feature-to-feature relationship. Since the holes are not being measured back to the datums, the center of these smaller rings need not be aligned with the center of the coordinate grid. The overlay may be adjusted to an optimum position where all the holes fall inside their respective allowable tolerance zones, verifying that the holes are properly located one to the other. Fig. 18-10 illustrates the feature-to-feature verification for the example part.

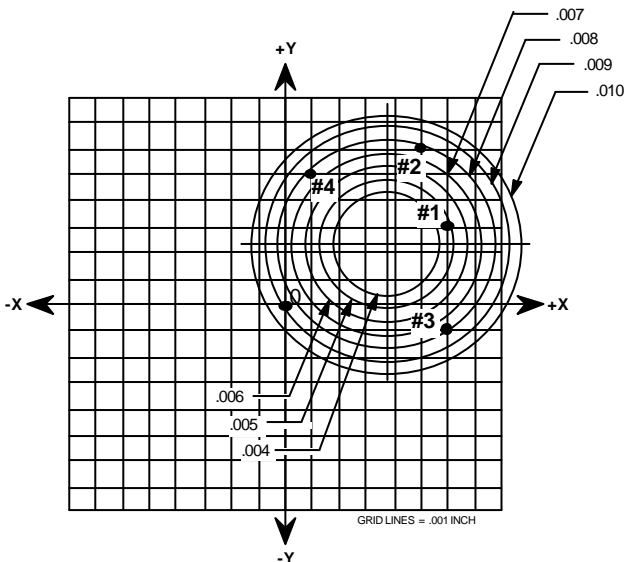

**Figure 18-10** Paper gage verification of feature-to-feature location

## 18.6.2 Capturing Tolerance from Datum Features Subject to Size Variation

In one common assembly application, a pilot hole or diameter is used as a datum feature in locating a pattern of holes. Paper gaging is extremely useful in capturing dynamic tolerances that cannot be effectively captured in a typical layout inspection.

### 18.6.2.1 Datum Feature Applied on an RFS Basis

Verification in relation to a datum feature of size applied on a regardless of feature size (RFS) basis is done in a similar manner to datum features without size discussed earlier. For the part shown in Fig. 18-11, locational verification of the hole pattern requires that the inspector establish a datum reference frame from the high points of datum feature A (primary) and center on the pilot diameter B (secondary) regardless of its produced size. Establishing the secondary datum axis requires use of an actual mating envelope (smallest circumscribed cylinder perpendicular to datum plane A) as the true geometric counterpart for secondary datum B.

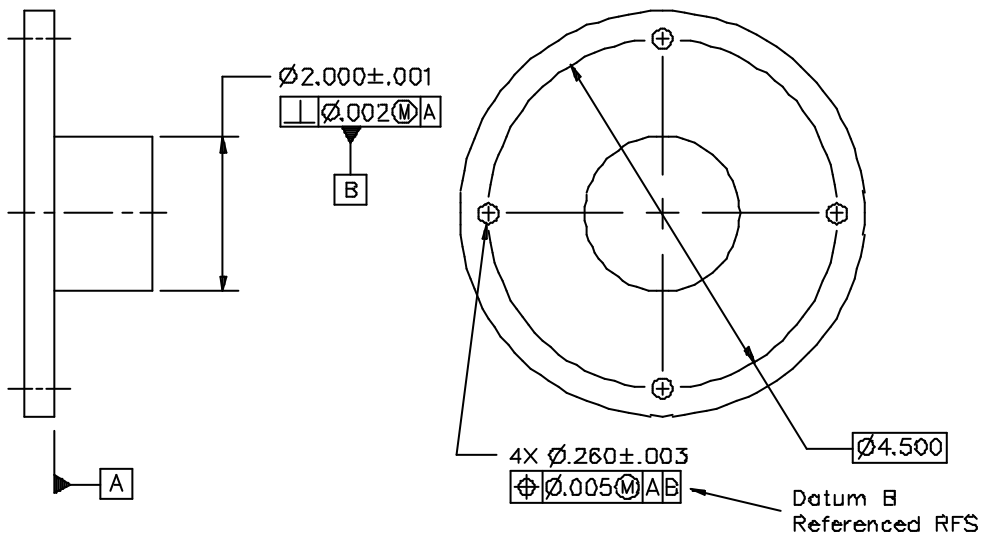

**Figure 18-11** Datum feature subject to size variation—RFS applied

With the part locked into the datum reference frame, measurements are made in an “X” and “Y” direction and the data is recorded on the Inspection Report. The data is then transferred to the coordinate paper gage grid and converted into a round positional tolerance using the polar overlay. Since the datum feature has been referenced on an RFS basis, the polar overlay must remain centered on the coordinate grid to reflect the hole pattern centered on the datum feature, regardless of its produced size.

### 18.6.2.2 Datum Feature Applied on an MMC Basis

A fixed-limit boundary is used to represent the datum feature, where a datum feature of size is referenced on an MMC basis. For a primary datum feature of size, the boundary is the MMC size of the datum feature. For a secondary or tertiary datum feature of size, the boundary is the virtual condition of the datum feature. These boundaries are easily represented in a functional gage, allowing the datum feature to “rattle” around inside the boundary if the actual produced feature has departed its MMC or virtual condition size.

This rattle is commonly referred to as “datum shift” and is allowed to occur every time a datum feature of size is referenced on an MMC basis. However, unlike “bonus” tolerance, this shift allowance is not additive to the location tolerance indicated by the feature control frame for the holes. Rather, datum shift allows the pattern tolerance zone framework to shift off the datum axis (all the holes as a group) to get the controlled features in the tolerance zones.

This concept of allowing the actual datum feature to shift off the center of the datum simulator cannot be readily captured when verifying parts in a dimensional layout inspection. This is because conventional dimensional metrology equipment usually requires that the inspector “center-up” on features in order to take measurements. For a layout inspection, paper gaging may be the only way the inspector can capture these dynamic datum shift allowances.

Fig. 18-12 illustrates an example where a datum shift tolerance has been allowed for a geometric tolerance. The three holes and the outside shape are located in relation to the face (primary datum A) and the large diameter hole in the center (secondary datum B at MMC). Let’s see how the datum shift tolerance might be captured by the inspector in this setup.

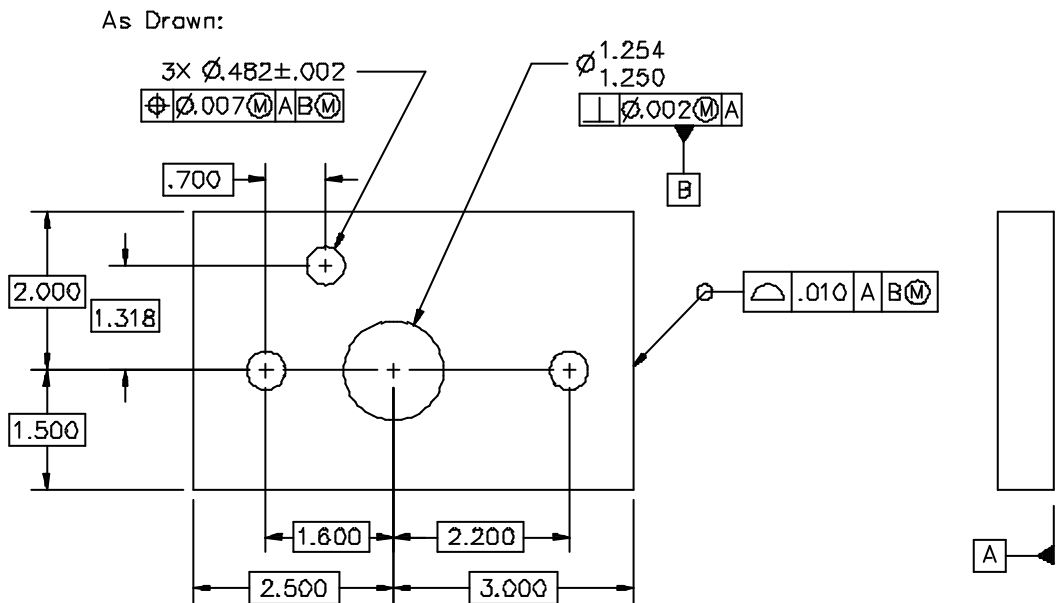

**Figure 18-12** Paper gage verification for datum applied at MMC

A layout inspection of this part would begin with the inspector inserting the largest pins that could be placed inside the holes as a means of verifying their size. The part must then be locked into the datum reference frame by setting up to the face first (primary datum plane A) and centering on the large hole (secondary datum axis B). To provide direction for the measurements, one of the three smaller holes is arbitrarily selected to antirotate the part. The final measurement layout might resemble the setup illustrated in Fig. 18-13.

The inspector extracts actual measurements in an “X” and “Y” direction from the established frame of reference, as well as produced sizes and calculations for the allowable positional tolerances on each hole.

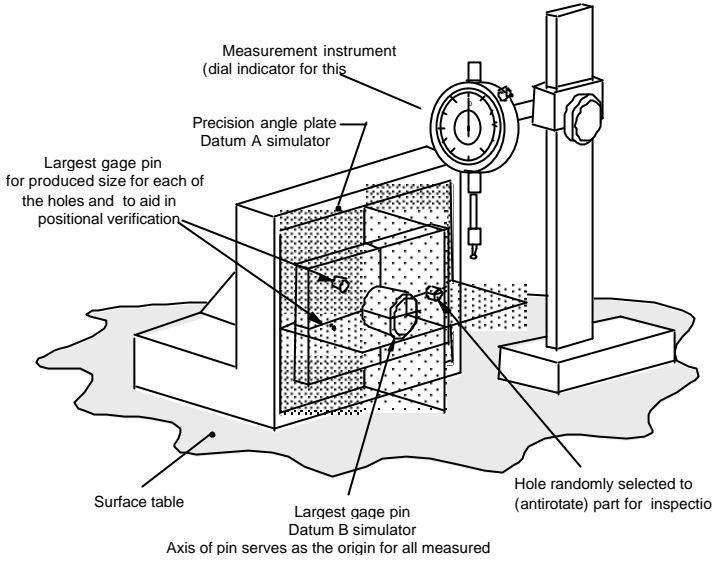

**Figure 18-13** Layout inspection setup of workpiece

The amounts each hole deviated from the basic dimensions as defined by the engineering drawing are entered in the Inspection Report as “X” and “Y” deviations as shown in Fig. 18-14.

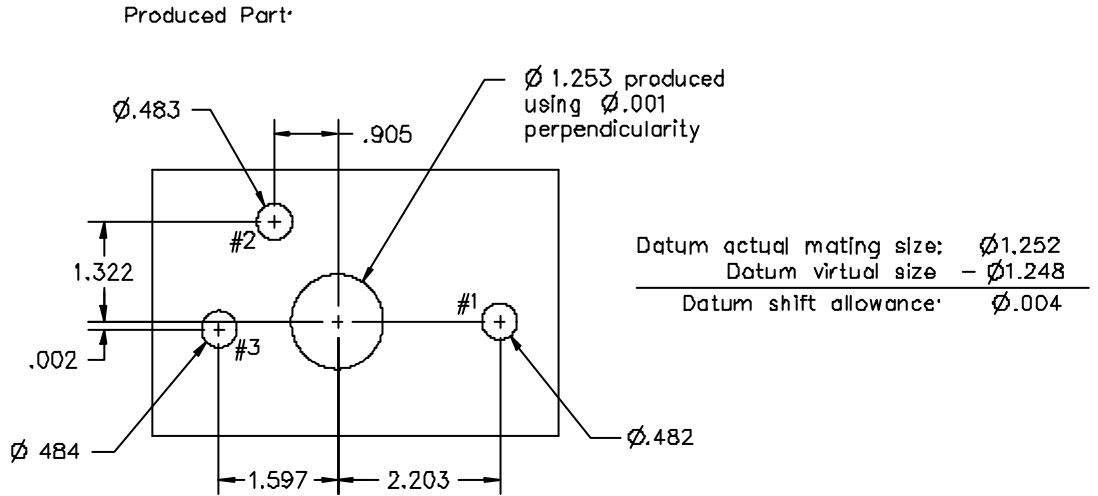

| LAYOUT INSPECTION REPORT |           |              |        |      |            |            |        |       |            |        |       |        |        |
|--------------------------|-----------|--------------|--------|------|------------|------------|--------|-------|------------|--------|-------|--------|--------|
| NO.                      | FEATURE   | FEATURE SIZE |        |      | ALLOW TOL. | X LOCATION |        |       | Y LOCATION |        |       | ACCEPT | REJECT |
|                          |           | MMC          | ACTUAL | DEV. |            | BASIC      | ACTUAL | DEV.  | BASIC      | ACTUAL | DEV.  |        |        |
| 1                        | .482±.002 | .480         | .482   | .002 | Ø.009      | 2.200      | 2.203  | +.003 | 0          | 0      | 0     | X      |        |
| 2                        | .482±.002 | .480         | .483   | .003 | Ø.010      | -.900      | -.905  | -.005 | 1.318      | 1.322  | +.004 | X      |        |
| 3                        | .482±.002 | .480         | .484   | .004 | Ø.011      | -1.600     | -1.597 | +.003 | 0          | -.002  | -.002 | X      |        |

**Figure 18-14** Inspection Report — part allowing datum shift

Using the data from the Inspection Report, the information is transferred to the paper gage by plotting each of the holes on a coordinate grid (which represents the inspector's measurements) as shown in Fig. 18-15. The center of this grid represents the basic or true position for each of the holes, as well as the center of the datum reference frame. The actual hole locations relative to their true position is plotted on the grid using the X and Y deviations from the inspector's measurements.

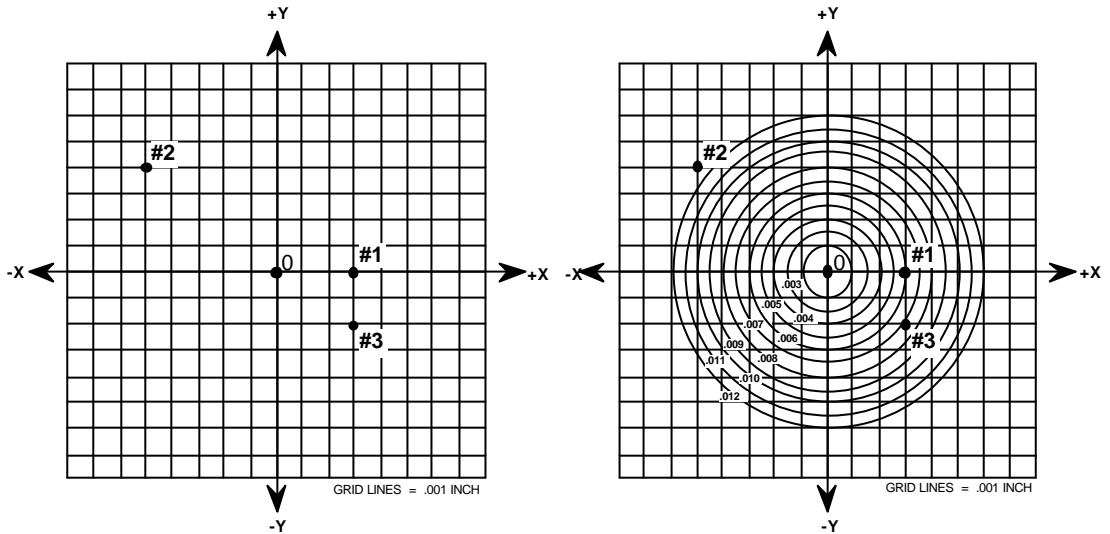

**Figure 18-15** Verifying hole pattern prior to datum shift

Once the holes have been plotted onto the coordinate grid, a polar grid (representing the round positional tolerance zones) is laid over the coordinate grid as shown in Fig. 18-15 (right), with the centers of the two grids aligned. The inspector then looks to see that each plotted hole falls inside its total allowable position tolerance. If all the holes fall inside their zones, the part is good and the inspector is done.

But, for the example shown, hole #2 falls well outside the  $\varnothing.010$  positional tolerance allowed for a  $\varnothing.483$  hole when the polar grid is centered on the coordinate grid. Even enlarging the hole to its largest size of  $\varnothing.484$  would not add enough bonus tolerance to make the part good. But, is the part really bad?

Remember that when the holes were inside their tolerance “rings,” the two grids were aligned, with one on the center of the other (RFS). But the drawing references datum B on an MMC basis requiring that a fixed-limit, virtual condition cylinder represent the datum. Comparing the actual mating size of datum feature B to its calculated virtual condition size shows that there is a  $\varnothing.004$  difference between the two. This difference reflects the shift tolerance allowed for the datum feature. This allowable shift may be translated to the hole verification by moving the polar grid such that the center of the coordinate grid remains inside a  $\varnothing.004$  zone when measuring the holes as shown in Fig. 18-16.

This movement between the two grids represents the allowable shift derived from the datum feature's departure from virtual condition. When shifting the polar grid in this manner, care must be taken to assure that all of the holes fall within their respective tolerance zones. If the polar grid can be moved to an optimum position that accepts all of the holes in their tolerance zones without violating the datum shift tolerance zone, then the hole pattern is accepted as being within tolerance.



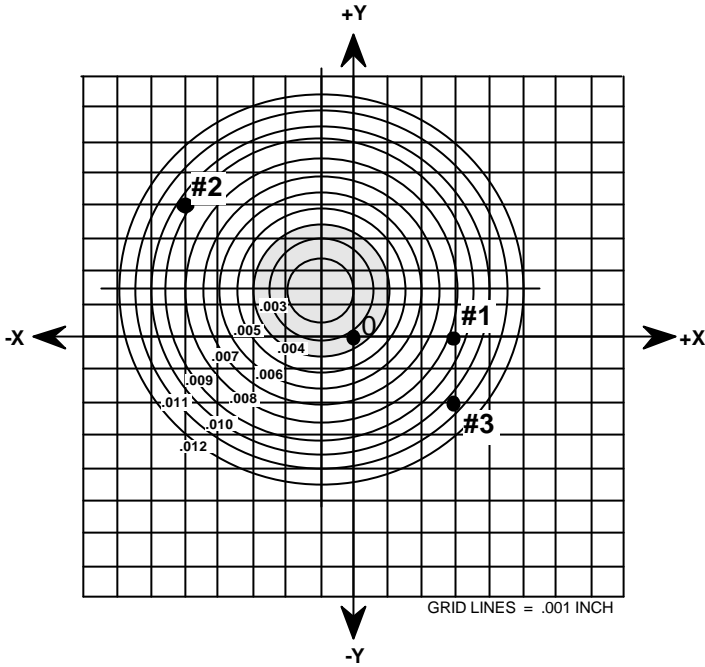

Figure 18-16 Verifying the hole pattern after datum shift

### 18.6.2.3 Capturing Rotational Shift Tolerance from a Datum Feature Applied on an MMC Basis

For the cylindrical part in Fig. 18-17, the hole pattern must be oriented in relation to the tertiary datum slot, referenced on an MMC basis. If the slot were to be simulated in a functional gage, a virtual condition width would be used as the true geometric counterpart for datum feature C. As the produced slot departed virtual condition (it is produced at a larger size and/or uses less of its allowed positional tolerance) the

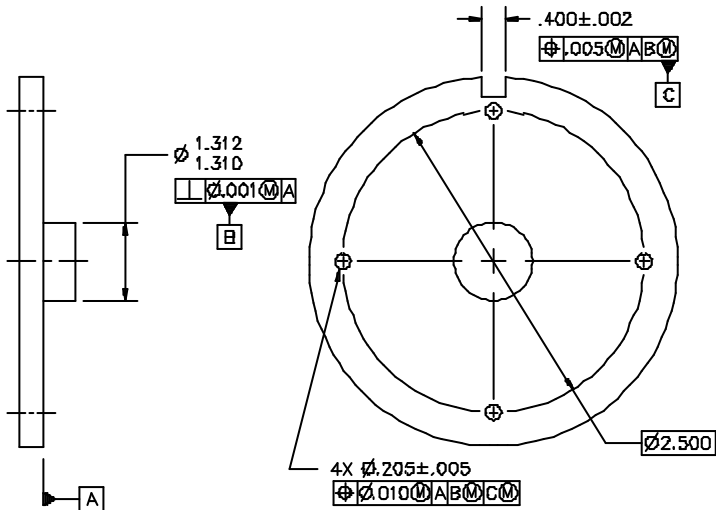
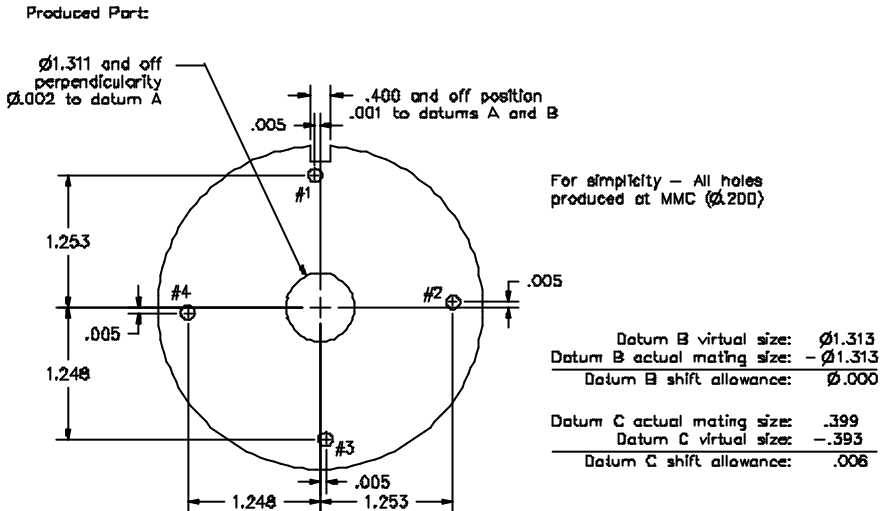

Figure 18-17 Part allowing rotational datum shift

entire hole pattern, as a group, would be allowed to rotate in relation to the true geometric counterpart of datum feature C when verifying the position for the hole pattern.

As with previous examples, the inspector would lock the part into the datum reference frame as prescribed by the drawing and collect the measurement data for the hole locations. The extracted measurements would then be delineated on the Inspection Report as shown in Fig. 18-18.



| LAYOUT INSPECTION REPORT |                 |              |        |      |                    |            |        |       |            |        |       |        |        |
|--------------------------|-----------------|--------------|--------|------|--------------------|------------|--------|-------|------------|--------|-------|--------|--------|
| NO.                      | FEATURE         | FEATURE SIZE |        |      | ALLOW TOL.         | X LOCATION |        |       | Y LOCATION |        |       | ACCEPT | REJECT |
|                          |                 | MMC          | ACTUAL | DEV. |                    | BASIC      | ACTUAL | DEV.  | BASIC      | ACTUAL | DEV.  |        |        |
| 1                        | $.205 \pm .005$ | .200         | .200   | 0    | $\varnothing .010$ | 0          | -.005  | -.005 | 1.250      | 1.253  | +.003 | X      |        |
| 2                        | $.205 \pm .005$ | .200         | .200   | 0    | $\varnothing .010$ | 1.250      | 1.253  | +.003 | 0          | +.005  | +.005 | X      |        |
| 3                        | $.205 \pm .005$ | .200         | .200   | 0    | $\varnothing .010$ | 0          | +.005  | +.005 | -1.250     | -1.248 | +.002 | X      |        |
| 4                        | $.205 \pm .005$ | .200         | .200   | 0    | $\varnothing .010$ | -1.250     | -1.248 | +.002 | 0          | -.005  | -.005 | X      |        |

Figure 18-18 Inspection Report—part allowing rotational datum shift

To focus on the datum shift derived from the slot, assume that all the holes are produced at MMC of  $\varnothing.200$  and that the secondary datum pilot B is produced at its virtual condition, providing no datum shift itself. When the holes are plotted onto the grid as shown in Fig. 18-19, they all fall outside the  $\varnothing.010$  positional tolerance allowed for a  $\varnothing.200$  hole.

Since datum feature B was produced at its virtual condition (thereby allowing no datum shift), the polar grid must remain on the center of the coordinate grid. However, datum feature C (the slot) did depart from its virtual condition, allowing datum shift for the hole pattern in the form of rotation of the pattern.

Calculations show that the slot departed its virtual condition by .006 total. However, since the holes are closer to the center of rotation than is the slot, we may only realize a portion of the available .006 shift provided by the slot at the holes themselves. Since the holes lie roughly 80% of the distance from the rotational center to the center of the slot, it can be assumed that only about 80% of the .006 rotational shift tolerance will occur at the axis of the holes, or an estimated .005. This means that the hole pattern may be rotated by  $\pm .0025$  from its current position in an attempt to get all the holes inside the  $\varnothing.010$  positional tolerance zone.

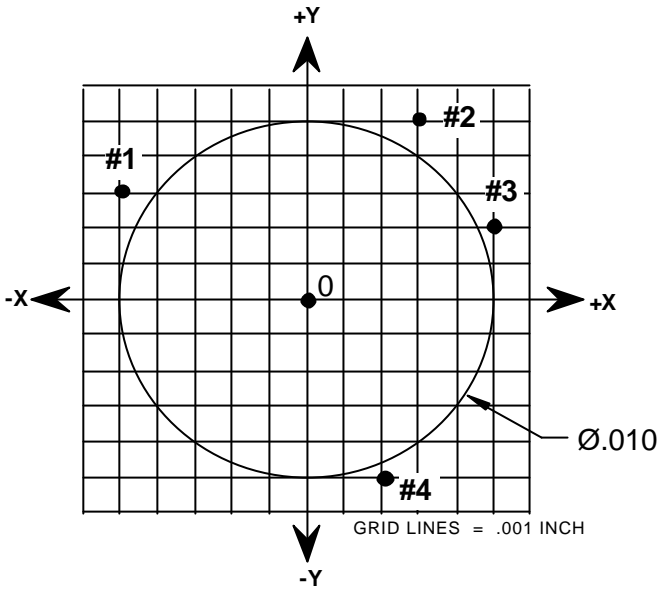

**Figure 18-19** Verifying hole pattern prior to rotational shift

When the part is rotated, the holes will move (as a group) to a new location on the coordinate grid. If the part is rotated clockwise by .0025, hole #1 will shift to the right, hole #2 will shift down, hole #3 will shift to the left, and hole #4 will shift up. Fig. 18-20 illustrates how, after rotation, the pattern moves closer to the center, resulting in all of the hole axes falling well inside the allowable  $\varnothing.010$  positional tolerance zone.

Use of the paper gage illustrated provides an approximate evaluation for the hole pattern. To prove the results, the inspector could reset the part for a second inspection using the new alignment for datum feature C.

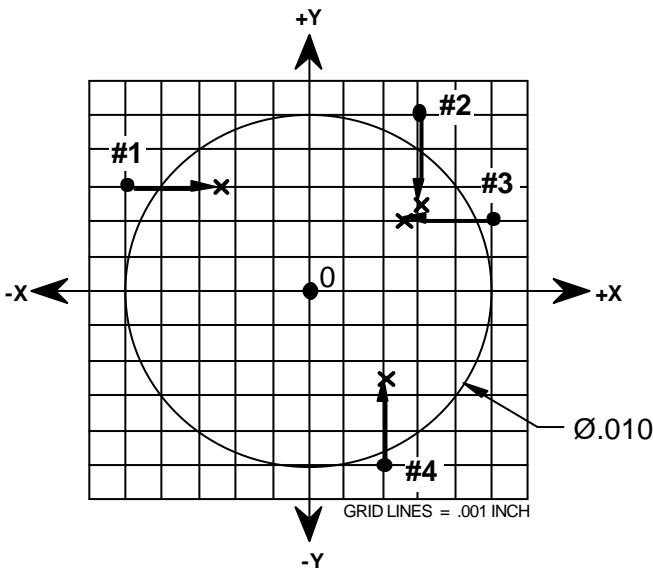

**Figure 18-20** Verifying hole pattern after rotational datum shift

### 18.6.2.4 Determining the Datum from a Pattern of Features

Where a pattern of features, such as a hole pattern, are used as a datum feature at MMC, the true geometric counterpart of all holes in the pattern are used in establishing the datum. For the example shown in Fig. 18-21, the true geometric counterpart for the pattern of three round holes consists of three true cylinders representing the virtual condition of each hole in the pattern. (Using virtual condition cylinders compensates for any locational error between the holes.) When referenced on an MMC basis, the axis of the pattern may shift and/or rotate within the bounds of these cylinders as the holes in the pattern depart from virtual condition (i.e., they grow larger in size and/or use less positional tolerance).

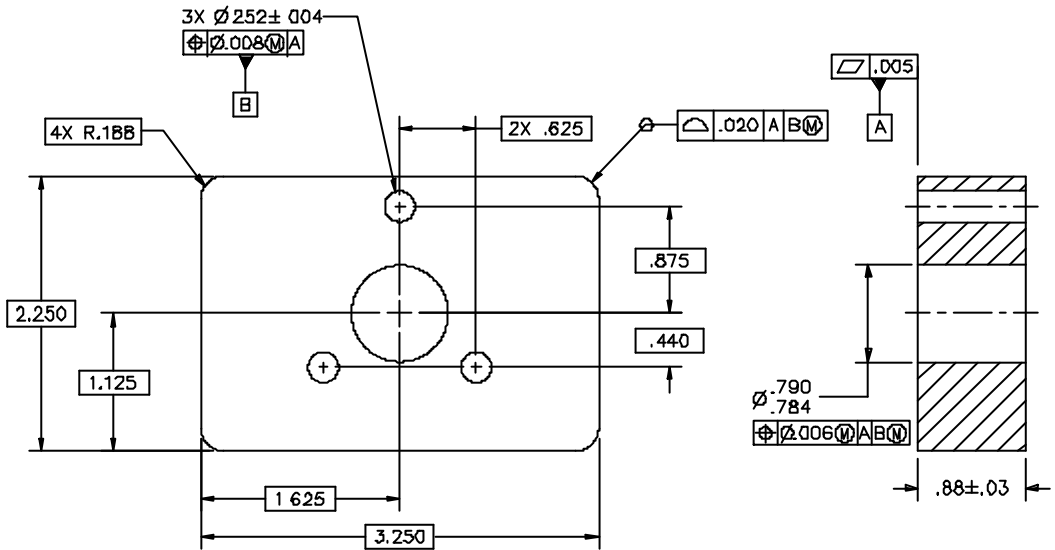
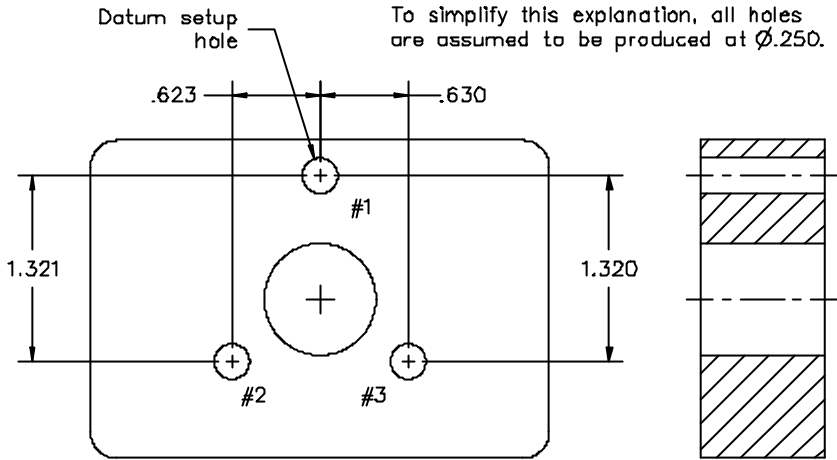

**Figure 18-21** Example of datum established from a hole pattern

These virtual condition “cylinders” may be represented by pins in a functional gage. By simply dropping the part over the gage pins, the produced hole pattern will average over the pins, relating the part to datum axis B. But, development of a hard gage is not required to simulate the averaging of the feature pattern to establish the datum. The drawing in Fig. 18-21 shows a part where the three-hole pattern will serve as secondary datum feature B at MMC. Since this part will be made in a very small quantity, it would not be practical or cost effective to build a gage to simulate the datum. Verification of the geometric tolerances will be done using a conventional layout inspection and paper gaging.

To establish the datum reference frame from a pattern of holes in an open setup or CMM, the hole pattern must be “averaged” to find a “best fit” center for the pattern. This might be accomplished by randomly selecting any hole of the pattern from which to start measuring. The remaining holes may be checked to this “frame of reference” as well as other geometric tolerances related to the datum hole pattern. Fig. 18-22 illustrates the measurements extracted for the three-hole datum pattern where the inspector used the top hole as the starting point.

If all tolerances check within their respective zones, then the part is accepted. If the part checks to be bad, then the inspector may need to paper gage the actual measurements taken for the holes to find the pattern center. This would be done by plotting the holes on the grid and then graphically “squaring up” the pattern by rotating the holes about the datum setup hole until they are equally dispersed in relation to



| LAYOUT INSPECTION REPORT |           |              |        |      |            |            |        |       |            |        |       |        |        |
|--------------------------|-----------|--------------|--------|------|------------|------------|--------|-------|------------|--------|-------|--------|--------|
| NO.                      | FEATURE   | FEATURE SIZE |        |      | ALLOW TOL. | X LOCATION |        |       | Y LOCATION |        |       | ACCEPT | REJECT |
|                          |           | MMC          | ACTUAL | DEV. |            | BASIC      | ACTUAL | DEV.  | BASIC      | ACTUAL | DEV.  |        |        |
| 1                        | .252±.004 | .248         | .250   | .002 | Ø.010      | 0          | 0      | 0     | 0          | 0      | 0     | X      |        |
| 2                        | .252±.004 | .248         | .250   | .002 | Ø.010      | -.625      | -.623  | +.002 | -1.315     | -1.321 | -.006 | X      |        |
| 3                        | .252±.004 | .248         | .250   | .002 | Ø.010      | .625       | .630   | +.005 | -1.315     | -1.320 | -.005 | X      |        |

Figure 18-22 Inspection Report—hole pattern as a datum

the coordinate grid centerlines as illustrated in Fig. 18-23 (left). To square up the pattern for this example, the part is rotated clockwise by .0035”.

By circumscribing the smallest diameter about the plotted holes, the “axis of the feature pattern” (best-fit center) for the pattern of holes may be approximated. For the example in Fig. 18-23 (right), the inspector would need to reset the origin for measurement by -.00075 in the “X” direction and -.003 in the “Y” direction to get the actual measurements from the pattern center.

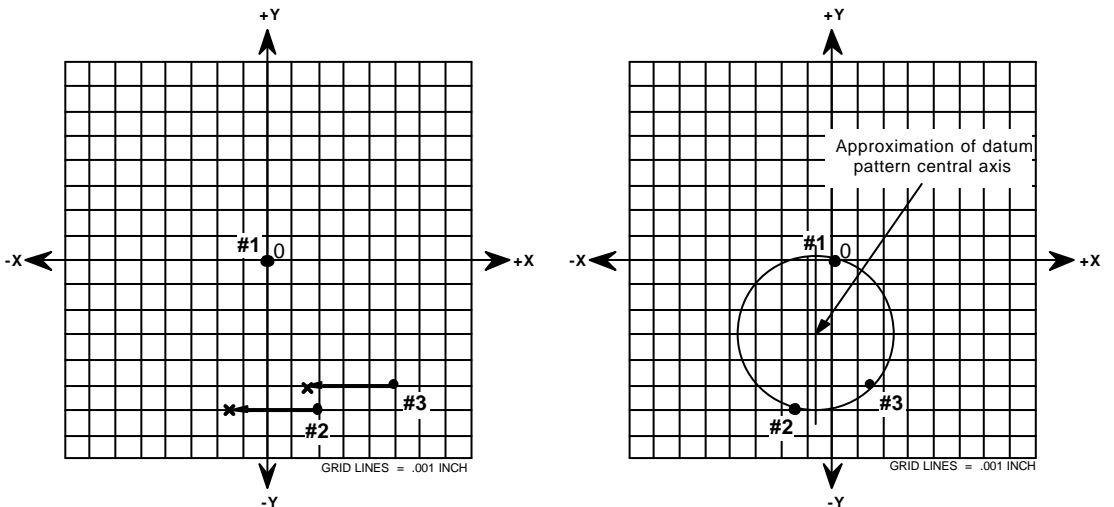
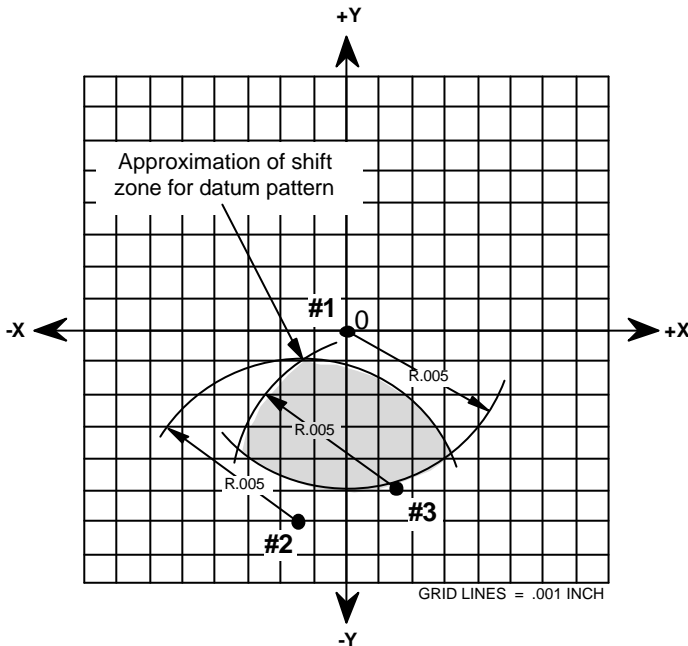

Figure 18-23 Determining the central datum axis from a hole pattern

Since the hole pattern is referenced on an MMC basis, the part would be allowed to shift and/or rotate in relation to the datum reference frame as the holes of the datum feature pattern depart from virtual condition. The amount of shift for the hole pattern may be determined on the paper gage by striking an arc representing the allowed positional tolerance for each of the plotted holes as shown in Fig. 18-24. The resulting area where the tolerance zones overlap approximates the pattern's departure from virtual condition (available datum shift tolerance).

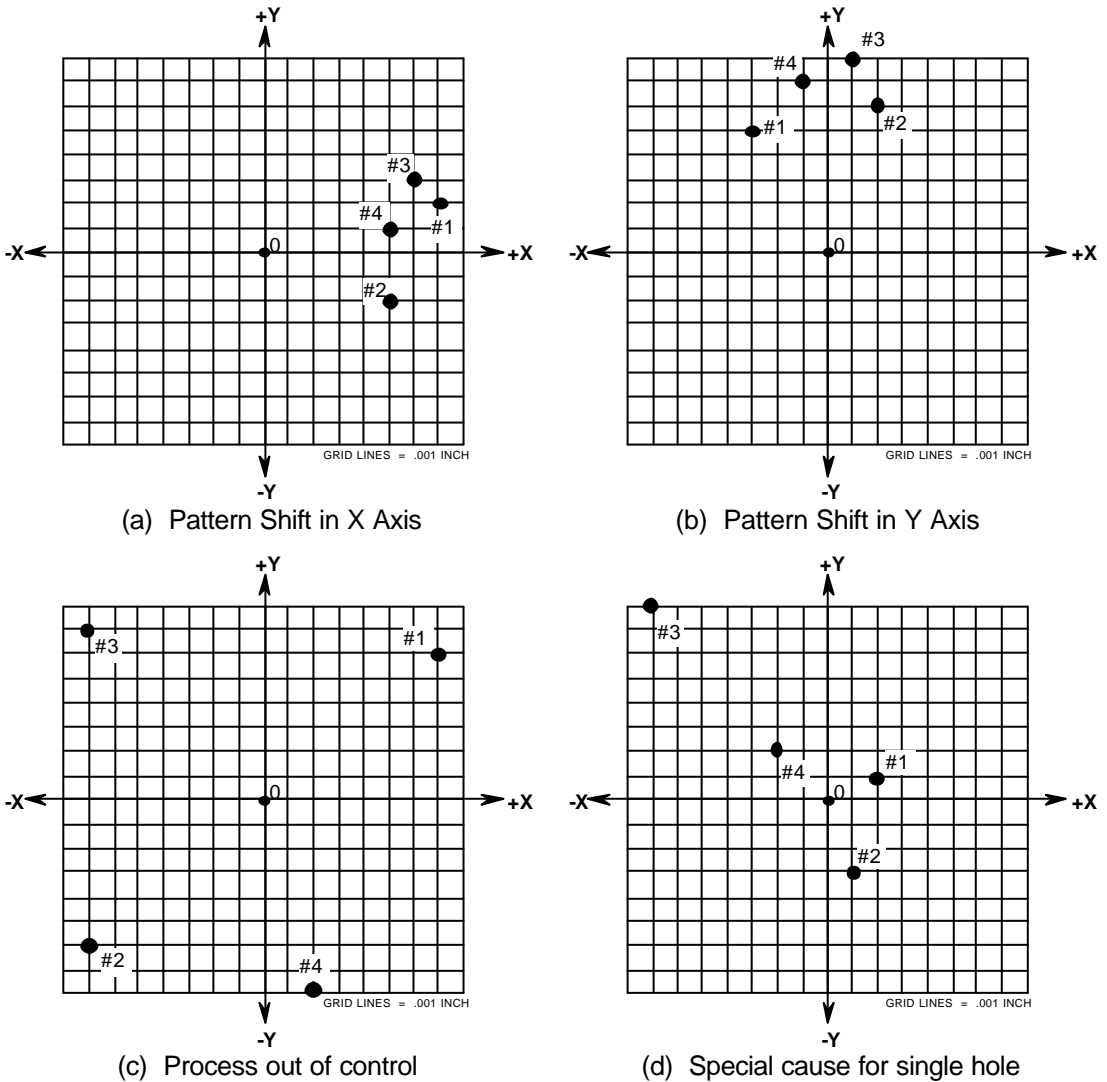

**Figure 18-24** Approximating datum shift from a hole pattern

### 18.6.3 Paper Gage Used as a Process Analysis Tool

As stated earlier in the text, paper gaging techniques are excellent tools used in identifying problems during the manufacturing process. When the holes are plotted on the coordinate grid, they provide a graphical “picture” of the process that can help identify production problems and isolate their root cause. Periodic paper gage evaluations, combined with accepted statistical methods, can assist the operator in keeping the process in control *before* bad parts are produced. This can significantly reduce production costs by raising the usable output, lowering scrap rates, and eliminating wasted man-hours attempting to salvage defective parts. Fig. 18-25 illustrates several production problems that may be identified using paper gage techniques.

In Fig. 18-25 (a and b), it appears that the process is quite capable of producing the parts since the holes on both grids fall together in a relatively close grouping. The problem for these parts seems to be that the pattern has drifted off center; one pattern along the X axis (Fig. 18-25a) and the other along the Y axis (Fig. 18-25b). This may have resulted from movement of the stops used to locate the part in the machinery. It may have resulted from something preventing the part from coming down fully to the stops, such as excessive chips on the machine bed. The amount of correction required can be determined by circumscribing the smallest possible circle about the hole grouping. This roughly approximates the center of the pattern. By simply counting the grid lines between the center of this circle and the center of the coordinate grid, the operator may determine the amount of adjustment required to get the pattern back on center.



**Figure 18-25** Process evaluation using a paper gage

The coordinate grid shown in Fig. 18-25(c) illustrates a hole pattern that is widely scattered over the coordinate grid and falls toward the extremes of the tolerance limits. The accuracy of the hole pattern is poor, and the reliability is questionable since a minor change in the process could result in one or more of the holes dropping outside their allowable tolerance. This could indicate an unstable or out-of-control process.

Fig. 18-25(d) illustrates a hole pattern where one of the holes (hole #3) has deviated to an extreme from the others. The remaining three holes fall as a group relatively close to the grid center, indicating a generally accurate and reliable process for the majority of the holes. This is a clear indicator that hole #3 deviated due to some special cause. Paper gaging additional parts would help to determine if this were a single occurrence or an ongoing problem requiring additional corrective action.

## 18.7 Summary

Paper gaging is an extremely valuable dimensional analysis tool used in verifying a wide range of geometric tolerance applications. As illustrated in this chapter, the technique allows for the easy translation of 2-D coordinate measurements extracted from traditional layout inspections into round 3-D tolerance zones for verifying part conformance. The technique also provides an effective means for capturing dynamic tolerances, such as datum shift allowance, which cannot be realized in a traditional layout inspection.

Simplicity of preparation and use, combined with the pictorial form of data presentation, makes a paper gage extremely easy for the average person to read and understand. When used appropriately, a paper gage can also save time and money in part inspection through its ability to represent part functional boundaries without the high cost of designing, building, and maintaining a traditional hard gage.

This chapter has also demonstrated how a paper gage may be used as a manufacturing problem-solving tool to quickly identify and correct problems during production. Periodic paper gage evaluations, combined with accepted statistical methods, can greatly aid the operator in keeping the process in control before bad parts are produced. This can help to lower production costs by raising usable part yield, lowering scrap rates, and eliminating wasted man-hours attempting to salvage defective product.

## 18.8 References

1. Foster, Lowell W. 1986. *Geometrics II, The Application of Geometric Tolerancing Techniques*. Minneapolis, MN: Addison-Wesley Publishing Company, Inc.
2. Neuman, Alvin G. 1995. *Geometric Dimensioning and Tolerancing Workbook*. Longboat Key, FL: Technical Consultants, Inc.
3. Pruitt, George O. 1983. *Graphical Inspection Analysis*. Doc No. NWC TM 5154. China Lake, CA: U.S. Naval Weapons Center.
4. The American Society of Mechanical Engineers. 1995. *ASME Y14.5M-1994, Dimensioning and Tolerancing*. New York, New York: The American Society of Mechanical Engineers.