

P • A • R • T • 2

STANDARDS

Drawing Interpretation

Patrick J. McCuiston, Ph.D
Ohio University
Athens, Ohio

Patrick J. McCuiston, Ph.D., Senior GDTP, is an associate professor of Industrial Technology at Ohio University. Dr. McCuiston taught for three years at Texas A&M University and previously worked in various engineering design, drafting, and checking positions at several manufacturing industries. He has provided instruction in geometric dimensioning and tolerancing and dimensional analysis to many industry, military, and educational institutions. He also has published one book, several articles, and given several academic presentations on those topics and dimensional management. Dr. McCuiston is an active member of several ASME/ANSI codes and standards subcommittees, including Y14 Main Committee, Y14.3 Multiview and Sectional View Drawings, Y14.5 Dimensioning and Tolerancing, Y14.11 Molded Part Drawings, Y14.35 Drawing Revisions, Y14.36 Surface Texture, and B89.3.6 Functional Gages.

4.1 Introduction

The engineering drawing is one of the most important communication tools that a company can possess. Drawings are not only art, but also legal documents. Engineering drawings are regularly used to prove the negligence of one party or another in a court of law. Their creation and maintenance are expensive and time consuming. For these reasons, the effort made in fully understanding them cannot be taken for granted.

Engineering drawings require extensive thought and time to produce. Many companies are using three-dimensional (3-D) computer aided design databases to produce parts and are bypassing the traditional two-dimensional (2-D) drawings. In many ways, creating an engineering drawing is the same as a part production activity. The main *difference* between drawing production and part production is that the drawing serves many different functions in a company. Pricing uses it to calculate product costs. Purchasing uses it to order raw materials. Routing uses it to determine the sequence of machine tools used to produce the part. Tooling uses it to make production, inspection, and assembly fixtures. Production uses

the drawing information to make the parts. Inspection uses it to verify the parts have met the specifications. Assembly uses it to make sure the parts fit as specified.

This chapter provides a short drawing history and then covers the main components of mechanical engineering drawings.

4.2 Drawing History

The earliest known technical drawing was created about 4000 BC. It is an etching of the plan view of a fortress. The first written evidence of technical drawings dates to 30 BC. It is an architectural treatise stating the need for architects to be skillful as they create drawings.

The practice of drawing views of an object on projection planes (orthographic projection) was developed in the early part of the fifteenth century. Although none of Leonardo da Vinci's surviving drawings show orthographic views, it is likely that he used the technique. His treatise on painting used the perspective projection theory.

As a result of the industrial revolution, the number of people working for companies increased. This also increased the need for multiple copies of drawings. In 1876, the blueprinting machine was displayed at the bicentennial exposition in Philadelphia, PA. Although it was a messy process at first, it made multiple copies of large drawings possible. As drawings changed from an art form to a communication system, their creation also changed to a production activity.

From about 1750, when Gaspard Monge developed descriptive geometry practices, to about 1900, most drawings were created using first-angle projection. Starting in the late nineteenth century, most companies in the United States switched to third-angle projection. Third-angle projection is considered a more logical or natural positioning of views.

While it is common practice for many companies to create parts using a 3-D definition of the part, 2-D drawings are still the most widely used communication tool for part production. The main reason for this is, if a product breaks down in a remote location, a replacement part could be made on location from a 2-D drawing. The same probably would not be true from a 3-D computer definition.

4.3 Standards

If a machinist in a machine shop in a remote location is required to make a part for a US-built commercial aircraft, he or she must understand the drawings. This requires worldwide, standardized drafting practices. Many countries support a national standards development effort in addition to international participation. In the United States, the two groups of standards that are most influential are developed by the standards development bodies administered by the American National Standards Institute (ANSI) and the International Organization for Standardization (ISO). See Chapter 6 for a comparison of US and ISO standards.

4.3.1 ANSI

The ANSI administers the guidelines for standards creation in the United States. The American Society of Mechanical Engineers sponsors the development of the Y14 series of standards. The 26 standards in the series cover most facets of engineering drawings and related documents. Many of the concepts about how to read an engineering drawing presented in this chapter come from these standards. In addition to the Y14 series of standards, the complete library should also possess the B89 Dimensional Measurement standards series and the B46 Surface Texture standard.

4.3.2 ISO

The ISO, created in 1946, helped provide a structure to rebuild the world economy (primarily Europe) after World War II. Even though the United States has only one vote in international standards development, the US continues to propose many of the concepts presented in the ISO drafting standards.

4.4 Drawing Types

Of the many different types of drawings a manufacturing company might require, the three most common are note, detail, and assembly.

4.4.1 Note

Commonly used parts such as washers, nuts and bolts, fittings, bearings, tubing, and many others, may be identified on a note drawing. As the name implies, note drawings do not contain graphics. They are usually small drawings (A or A4 size) that contain a written description of the part. See Fig. 4-1.

4.4.2 Detail

The detail drawing should show all the specifications for one unique part. Examples of different types of detail drawings follow.

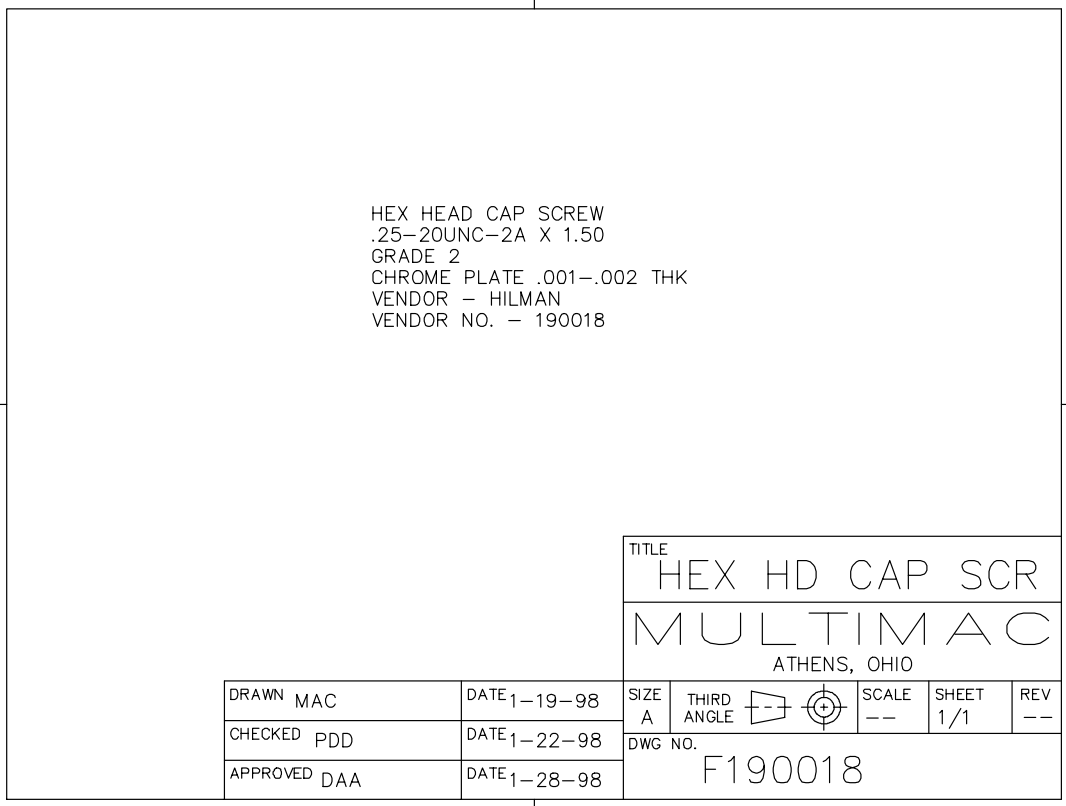

Figure 4-1 Note drawing

4.4.2.1 Cast or Forged Part

Along with normal dimensions, the detail drawing of a cast or forged part should show parting lines, draft angles, and any other unique features of the part prior to processing. See Fig. 4-2.

This drawing does not show any finished dimensions. Many companies combine cast or forged drawings with machined part drawings. Phantom lines are commonly used to show the cast or forged outline.

4.4.2.2 Machined Part

Finished dimensions are the main features of a machined part drawing. A machined part drawing usually does not specify how to achieve the dimensions. Fig. 4-3 shows a machined part made from a casting. Fig. 4-4 shows a machined part made from round bar stock.

4.4.2.3 Sheet Stock Part

Because there are different methods of forming sheet stock, drawings of these types of parts may look quite different. Fig. 4-5 shows a drawing of a structural component for an automobile frame. The part is illustrated primarily in 3-D with one 2-D view used to show detail. In these cases, the part geometry is stored in a computer database and is used throughout the company to produce the part. Fig. 4-6 shows a very different type of drawing. It is a flat pattern layout of a transition.

4.4.3 Assembly

Assembly drawings are categorized as subassembly or final assembly. Both show the relative positions of parts. They differ only in where they fit in the assembly sequence.

Assembly drawings are usually drawn in one of two forms: exploded pictorial view (see Fig. 4-7) or 2-D sectioned view (see Fig. 4-8). Two common elements of assembly drawings are identification balloons and parts lists. The item numbers in the balloons (circles with leaders pointing to individual parts) relate to the numbers in the parts list.

4.5 Border

The border is drawn around the perimeter of the drawing. It is a thick line with zone identification marks and centering marks. See Fig. 4-9.

4.5.1 Zones and Center Marks

The short marks around the rectangular border help to identify the location of points of interest on the drawing (similar to a road map). When discussing the details of a drawing over the telephone, the zone of the detail (A, 1 would be the location of the title block) is provided so the listener can find the same detail. This is particularly important for very detailed large drawings. The center marks, often denoted by arrows, are used to align the drawing on a photographic staging table when making microfilm negatives.

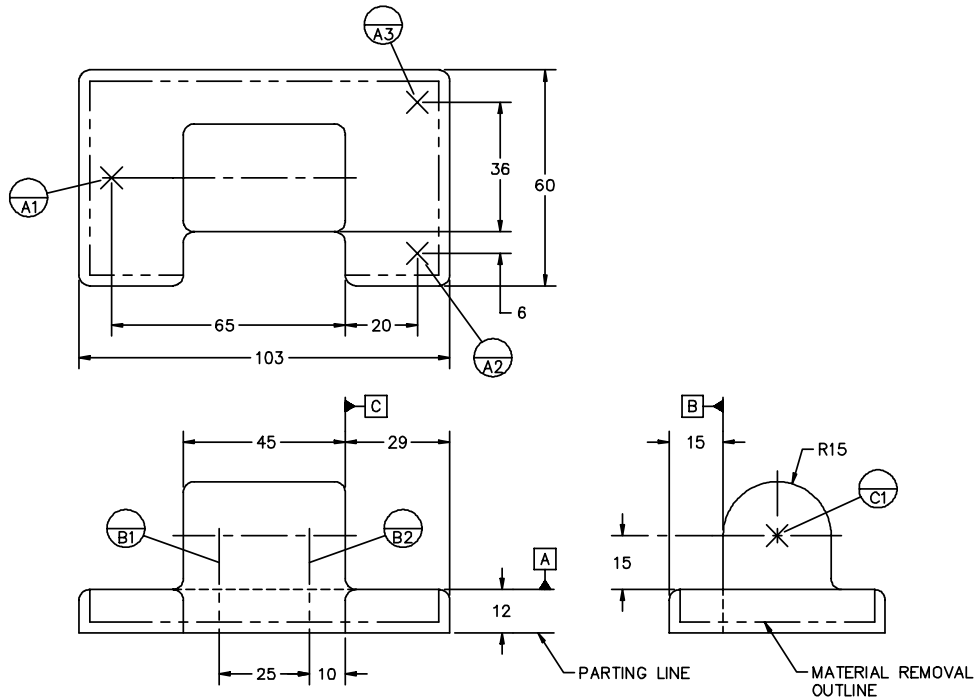

NOTES:

- 1 - ALL RADII 3
- 2 - ALL DIMENSIONS ARE BASIC
- 3 - $\square 0.5 \square A B C$
APPLIES TO ALL SURFACES
- 4 - 3 DEGREES DRAFT MAX

NOTICE TO PERSONS RECEIVING THIS DOCUMENT. BEAVER FALLS DESIGN CLAIMS PROPRIETARY RIGHTS IN THE INFORMATION DISCLOSED HEREON. THIS DOCUMENT IS ISSUED IN CONFIDENCE AND IS NOT TO BE REPRODUCED OR USED TO MANUFACTURE ANYTHING SHOWN HEREON WITHOUT THE WRITTEN PERMISSION OF BEAVER FALLS DESIGN.		UNLESS OTHERWISE SPECIFIED		TITLE BASE	
		ANSI Y14.5M-1994 APPLIES DO NOT SCALE DRAWING	SURFACE FINISH 12.5 ✓	BEAVER FALLS DESIGN BEAVER FALLS, WI	
HEAT TREAT NONE	MATERIAL CAST IRON	ANGULAR TOL - $\pm 5'$	LINEAR TOL	$X = \pm 1$ $X.X = \pm .1$ $X.XX = \pm .01$	SCALE 1:1
		DRAWN MURPHY	DATE 1-24-98	SIZE A3	THIRD ANGLE
		CHECKED HAMMOND	DATE 1-25-98	DWG NO.	SHEET 1/1
		APPROVED ROGERS	DATE 1-28-98	402505023	

Figure 4-2 Casting drawing

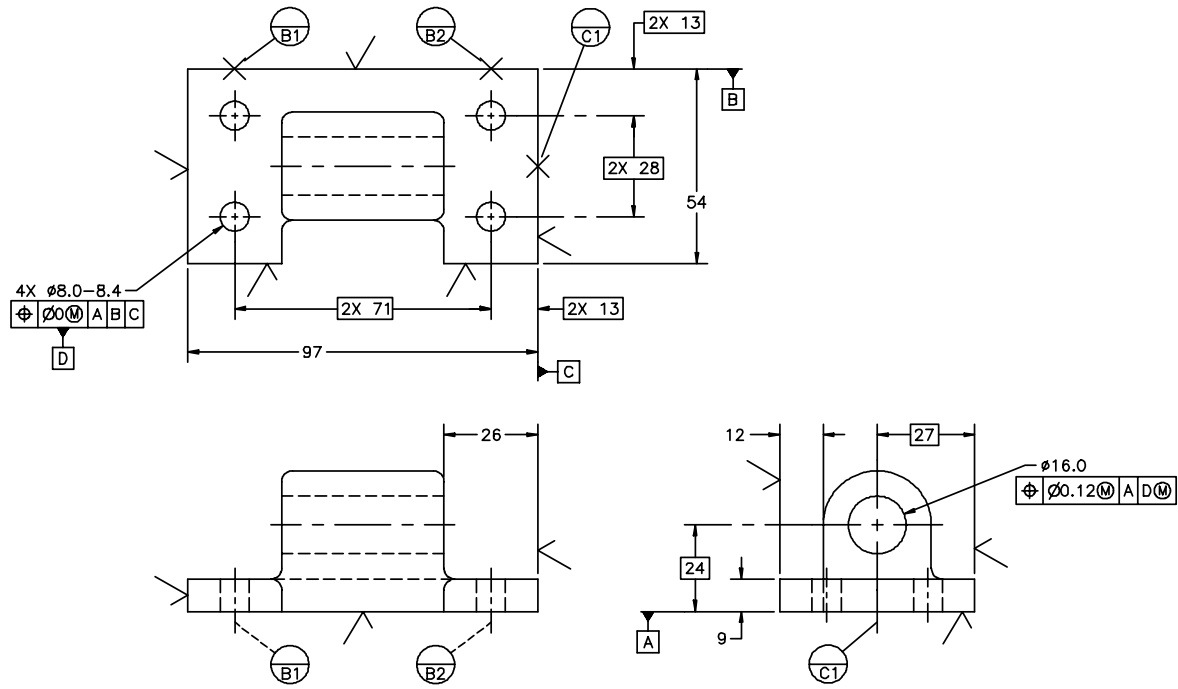

NOTICE TO PERSONS RECEIVING THIS DOCUMENT. BEAVER FALLS DESIGN CLAIMS PROPRIETARY RIGHTS IN THE INFORMATION DISCLOSED HEREON. THIS DOCUMENT IS ISSUED IN CONFIDENCE AND IS NOT TO BE REPRODUCED OR USED TO MANUFACTURE ANYTHING SHOWN HEREON WITHOUT THE WRITTEN PERMISSION OF BEAVER FALLS DESIGN.		UNLESS OTHERWISE SPECIFIED ANSI Y14.5M-1994 APPLIES DO NOT SCALE DRAWING		SURFACE FINISH 3.2 ✓ X = ±1 X.X = ±1 X.XX = ±0.1		TITLE BASE			
		ANGULAR TOL - ±5° CHAMFER TOL - ±5°	LINEAR TOL X = ±1 X.X = ±1 X.XX = ±0.1	BEAVER FALLS DESIGN BEAVER FALLS, WI			SIZE A3	THIRD ANGLE	SCALE 1:1
HEAT TREAT NONE	MATERIAL 402505023	DRAWN MURPHY	DATE 1-24-98	CHECKED HAMMOND	DATE 1-25-98	DWG NO. 402505024			
		APPROVED ROGERS	DATE 1-28-98						

Figure 4-3 Machined part made from casting

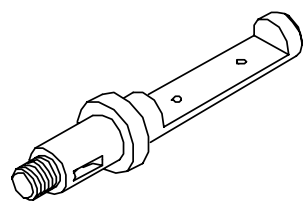
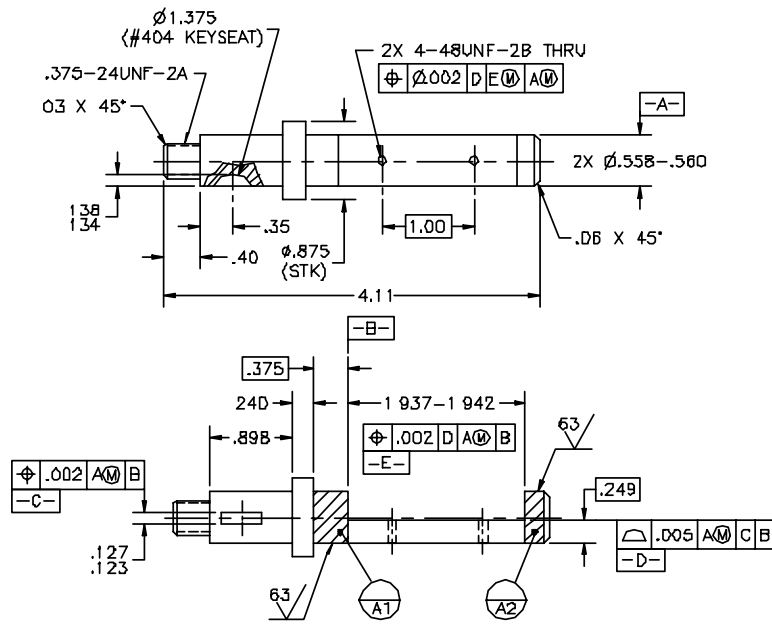

NOTICE TO PERSONS RECEIVING THIS DOCUMENT. DRAKE ENGINEERING CLAIMS PROPRIETARY RIGHTS IN THE INFORMATION DISCLOSED HEREON. THIS DOCUMENT IS ISSUED IN CONFIDENCE AND IS NOT TO BE REPRODUCED OR USED TO MANUFACTURE ANYTHING SHOWN HEREON WITHOUT THE WRITTEN PERMISSION OF DRAKE ENGINEERING.		UNLESS OTHERWISE SPECIFIED ANSI Y14.5M-1982 APPLIES SURFACE FINISH 125 ✓ DO NOT SCALE DRAWING		TITLE SHAFT	
HEAT TREAT NONE		MATERIAL 1018 CRS		DRAKE ENGINEERING RICHARDSON, TX	
CHECKED JANE		DATE 2-3-98		SIZE B	THIRD ANGLE
APPROVED ZIMMERMANN		DATE 2-8-98		SCALE 1:1	SHEET 1/1
				REV --	
				DWG NO. 204509432	

Figure 4-4 Machined part made from bar stock

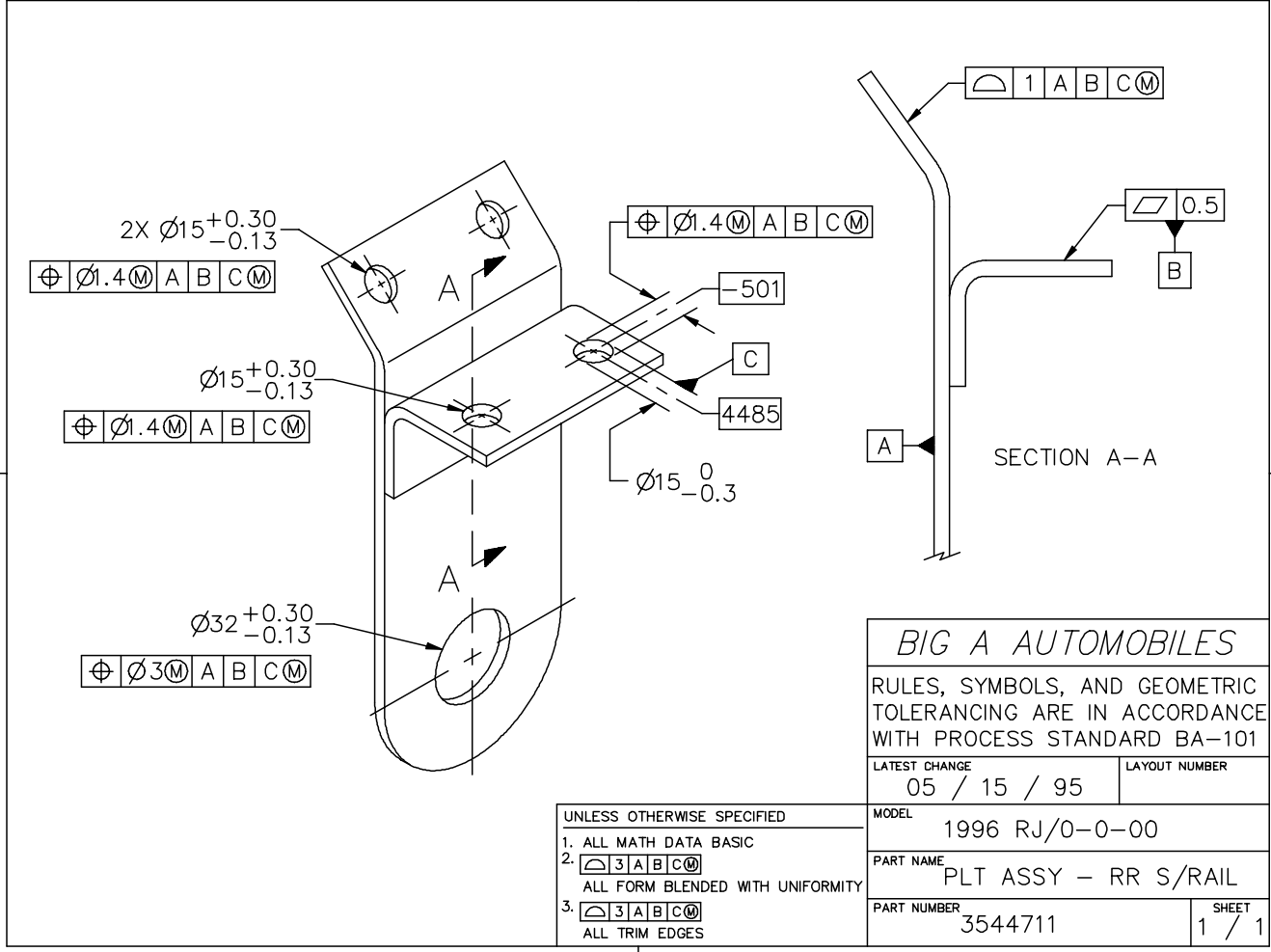

Figure 4-5 Stamped sheet metal part drawing

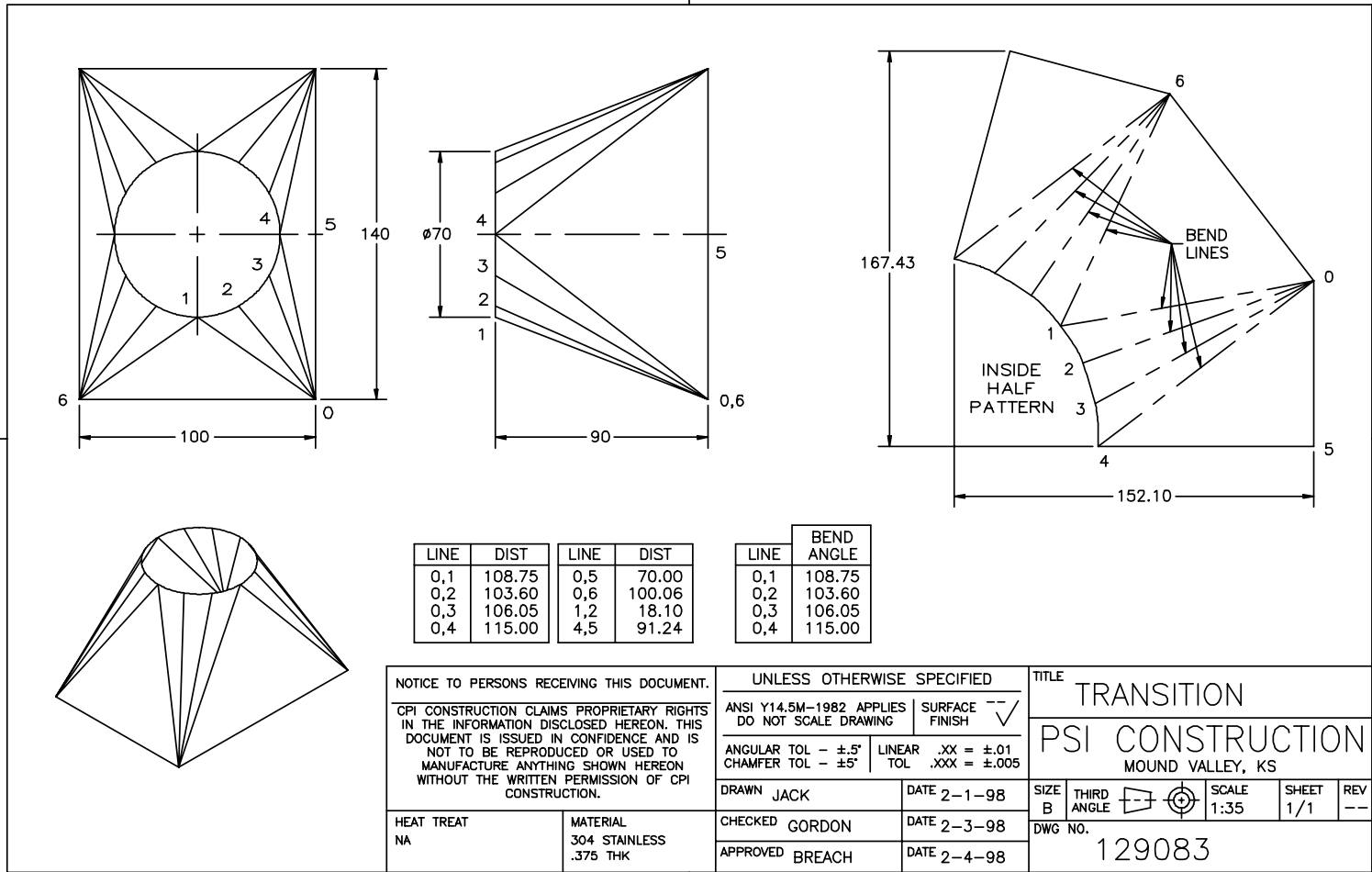

Figure 4-6 Flat pattern layout drawing

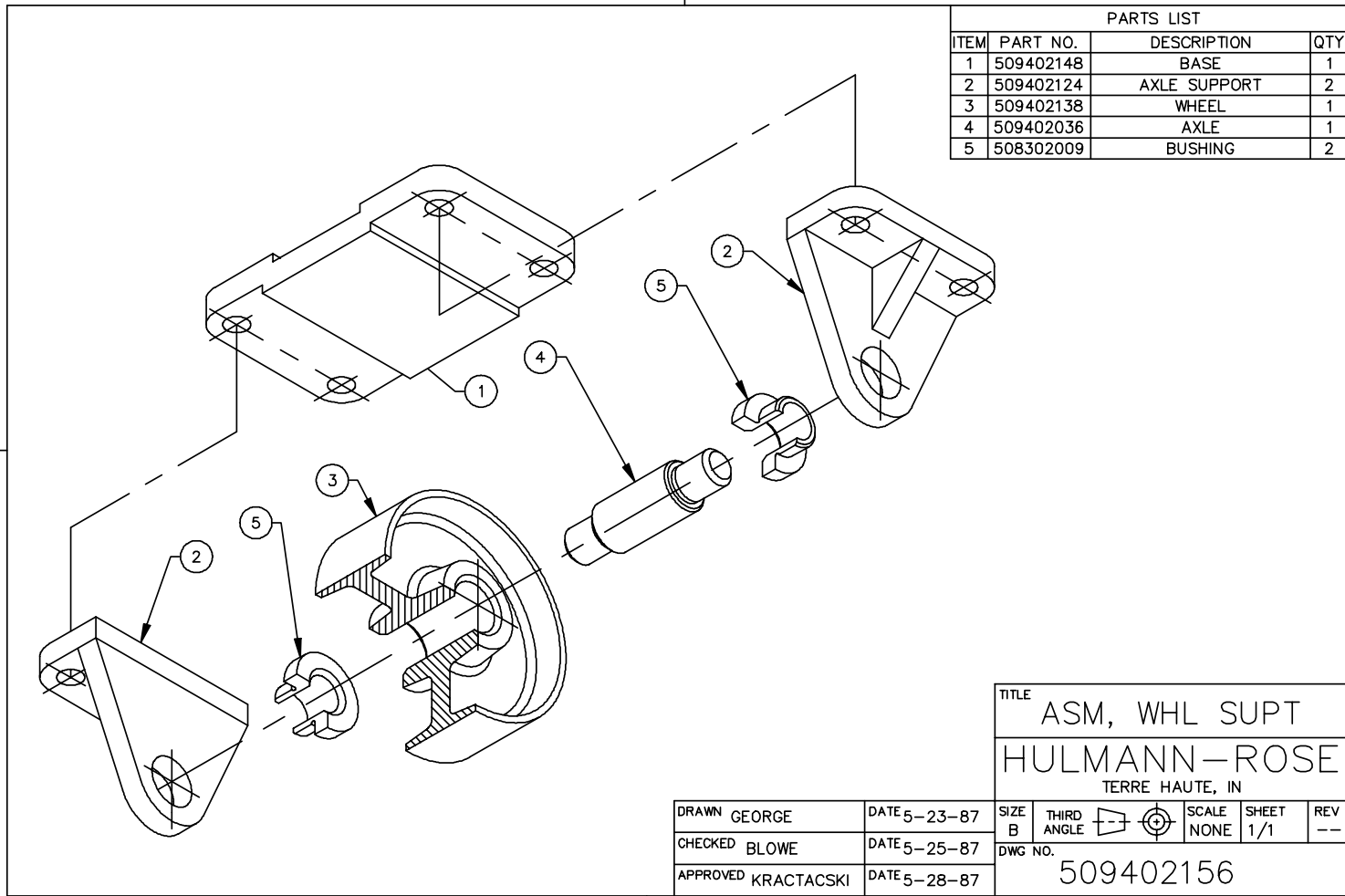
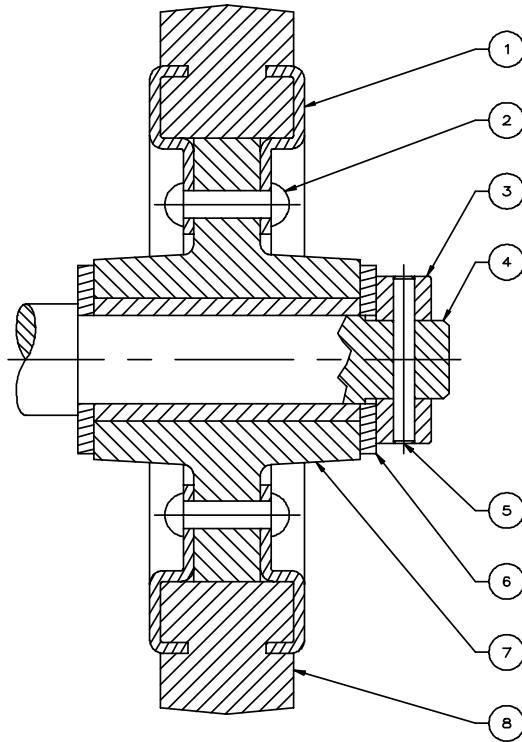

Figure 4-7 Exploded pictorial assembly drawing



PARTS LIST			
ITEM	PART NO.	DESCRIPTION	QTY
1	2048697	BRACKET	2
2	2048663	RIVET	6
3	2048641	RETAINER	1
4	2048621	SHAFT	1
5	2048642	PIN SPRING	1
6	2048643	SPACER	2
7	2048692	HUB WHEEL	1
8	2048682	WHEEL	1

NOTICE TO PERSONS RECEIVING THIS DOCUMENT.

BEAVER FALLS DESIGN CLAIMS PROPRIETARY RIGHTS IN THE INFORMATION DISCLOSED HEREON. THIS DOCUMENT IS ISSUED IN CONFIDENCE AND IS NOT TO BE REPRODUCED OR USED TO MANUFACTURE ANYTHING SHOWN HEREON WITHOUT THE WRITTEN PERMISSION OF BEAVER FALLS DESIGN.

DRAWN	WALLY COX	DATE	7-6-98
CHECKED	BOB WILD	DATE	7-7-98
APPROVED	ALI BENDROB	DATE	7-7-98

TITLE
 ASM WHEEL
 BEAVER FALLS DESIGN
 ATHENS, OHIO

SIZE	THIRD	SCALE	SHEET	REV
B	ANGLE	NONE	1/1	--

DWG NO. 2048698

INCH

Figure 4-8 2-D sectioned assembly drawing

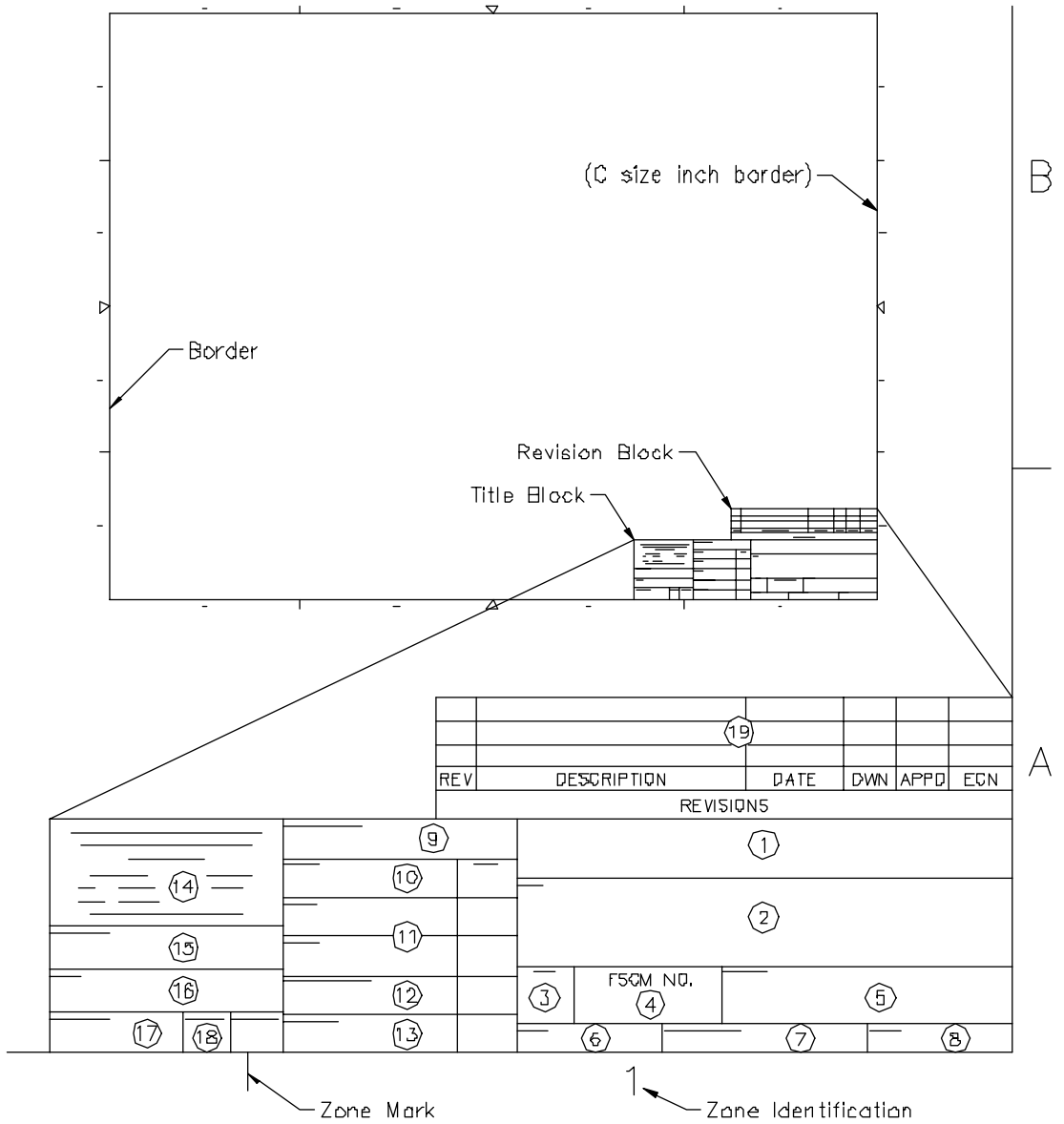

Figure 4-9 Border, title block, and revision block

4.5.2 Size Conventions

Most drawings conform to one of the sheet sizes listed below. If the drawing is larger than these sizes, it is generally referred to as a “roll size” drawing.

INCH		METRIC	
Code	Size	Code	Size
A	8.5 X 11	A4	210 X 297
B	11 X 17	A3	297 X 420
C	17 X 22	A2	420 X 594
D	22 X 34	A1	594 X 841
E	34 X 44	A0	841 X 1189

4.6 Title Blocks

The part of a drawing that has the highest concentration of information is usually the title block (see Fig. 4-9). It is the door to understanding the drawing and the company. Although there are many different arrangements possible, a good title block has the following characteristics.

- It is appropriate for the drawing type.
- It is intelligently constructed.
- It is filled in completely.
- All the signatures can be signed off within a short time frame.

Some drawing types will not use all of the following title block elements. For example: an assembly drawing may not require dimensional tolerances, surface finish, or next assembly. Although title block sizes and configurations have been standardized in ASME Y14.2, most companies will maintain the standard information but modify the configuration to suit their needs.

Reference Fig. 4-9 for the following standard title block items:

4.6.1 Company Name and Address

Many companies include their logo in addition to their name and address.

4.6.2 Drawing Title

When the drawing title is more than one word, it is often presented as the noun first and the adjective second. For example, SPRING PIN is written PIN, SPRING. This makes it easier to search all the titles when the first word is the key word in the title. There is no standard length for a title although many companies use about 15 character spaces. Abbreviations should not be used except for the words “assembly,” “subassembly,” and “installation,” and trademarked names.

4.6.3 Size

The code letter for the sheet size is noted here. See Section 4.5.2 for common sheet sizes.

4.6.4 FSCM/CAGE

If your business deals with the federal government, you have a Federal Supply Code for Manufacturer’s number. This number is the design activity code identification number.

4.6.5 Drawing Number

The drawing number is used for part identification and to ease storage and retrieval of the drawing and the produced parts. While there is no set way to assign part numbers, common systems are nonsignificant, significant, or some combination of the two previous systems.

Nonsignificant numbering systems are most preferred because no prior knowledge of significance is required.

Significant numbering systems could be used for commonly purchased items like fasteners. For example, the part number for a washer could include the inside diameter, outside diameters, thickness, material, and plating.

A combination of nonsignificant and significant numbering systems may use sections of the numbers in a hierarchical manner. For example, the last three digits could be the number assigned to the part (001, 002, 003, etc.). This would be nonsignificant. The remaining numbers could be significant: two numbers could be the model variation, the next two numbers could be the model number, and the next two could be the series number while the last two could be the project number. Many other possibilities exist.

4.6.6 Scale

There is no standard method of specifying the scale of a drawing. Scale examples for an object drawn at half its normal size are 1:2, 1=2, ½ or, HALF. They all mean the same thing. The first two examples are the easiest to use. If the one (1) is always on the left, the number on the right is the multiplication factor. For example, measure a distance on the drawing with a 1=1 scale and multiply that number by the number on the right (in this example, 2).

4.6.7 Release Date

This is the date the drawing was officially released for production.

4.6.8 Sheet Number

The sheet number shows how many individual sheets are required to completely describe a part. For many small parts, only one sheet is required. When parts are large, complicated, or both, multiple sheets are required. The number 4/12 would indicate the fourth (4) sheet of a twelve (12)-sheet drawing.

4.6.9 Contract Number

If this drawing was created as a part of a specific contract, the contract number is placed here. Other examples of drawing codes may be used to track the time spent on a project.

4.6.10 Drawn and Date

Some companies require the drafter to sign their name or initials. Other companies have the drafter type this information on the drawing. The date the drawing was started must be included.

4.6.11 Check, Design, and Dates

A drawing may be reviewed by more than one checker. For example, the drawing may go to a drafting checker first, then to a design checker, and maybe others. The checkers use the same method of identification as the drafters.

4.6.12 Design Activity and Date

As with checking, there may be multiple levels of approval before a document is released. The design activity is a representative of the area responsible for the design. All those approving the drawing use the same method of identification as the drafters.

4.6.13 Customer and Date

If the customer is required to approve the drawing, that name and date is placed here.

4.6.14 Tolerances

The items in this section apply unless it is stated differently on the field of the drawing. In addition to the general tolerance block that is shown in Fig. 4-9, other tolerance blocks might be used for sand casting, die casting, forging, and injection-molded parts.

Linear – Linear tolerances are presented in an equal format (\pm). It is also common to show multiple examples to indicate default numbers of decimal places.

Angular – Angular tolerances are also presented in an equal bilateral format (\pm). It is common to give one tolerance for general angles and a different tolerance for chamfers.

4.6.15 Treatment

Treatment might include manufacturing specifications, heat-treat notes, or plating specifications. Longer messages about processing are placed in a note. See Section 4.16.

4.6.16 Finish

The finish reveals the condition of part surfaces. It consists of roughness, waviness, and lay. The general surface roughness average is given in this space. See Section 4.15.

4.6.17 Similar To

Some companies prefer to have numbers of similar parts on the drawing in case the drawn part may be made from a like part.

4.6.18 Act Wt and Calc Wt

Providing the part weight on the drawing may help the personnel in the Routing area move the parts more efficiently.

4.6.19 Other Title Block Items

The part material must be stated on the drawing. The material is specified using codes provided by the Society of Automotive Engineers (SAE) or the American Society for Testing and Materials (ASTM).

The drawing number of the next assembly is often placed in the title block. Many standard parts have many different next assemblies. Each time a part is added to another assembly the drawing must be revised to add the next assembly number. The money spent maintaining these numbers causes some to question their value.

4.7 Revision Blocks

It is common for drawings to be revised several times for parts that are used for many years. During the life of a product, it may be revised to improve performance or reduce cost. After a drawing change request is made and accepted, the drawing is modified. Engineering change notices (ECN) are created to document the actual changes. The revision letter, description, date, drafter and approver identification, and ECN number are recorded in the revision block. See Fig. 4-9.

4.8 Parts Lists

A parts list names all the parts in an assembly. It lists the item number, description, part number, and quantity for each part in the assembly. The item number is placed in a circle (balloon) close to the part in the assembly view. A leader is drawn from the balloon pointing to the part. See Figs. 4-7 and 4-8.

4.9 View Projection

With the advent of orthographic (right-angle drawing) projection in the eighteenth century, battle fortifications could be visually described accurately and faster than mathematical methods. This contributed so much to Napoleon's success that it was kept secret during his time in power. Orthographic projection is a technique that uses parallel lines of sight intersecting mutually perpendicular planes of projection to create accurate 2-D views. The two variations most commonly used are first-angle and third-angle. As illustrated below, the names *first* and *third* relate into which 3-D quadrant the object is placed.

4.9.1 First-Angle Projection

The first-angle projection system is used primarily in Europe and other countries that only use ISO standards. When viewing a 2-D multiview drawing, the top view is placed below the front view and the right side view is placed on the left side of the front view. See Fig. 4-10.

4.9.2 Third-Angle Projection

The third-angle projection system is used primarily in the Americas. When viewing a 2-D multiview drawing, the top view is placed above the front view and the right side view is placed on the right side of the front view. See Fig. 4-11.

4.9.3 Auxiliary Views

Auxiliary views are those views drawn on projection planes other than the principal projection planes (see Figs. 4-12 and 4-19). Primary auxiliary views are drawn on projection planes constructed perpendicular to one of the principal projection planes. Successive auxiliary views are drawn on projection planes constructed perpendicular to any auxiliary projection plane.

4.10 Section Views

Section views show internal features of parts. Thin lines depict where solid material was cut. One of the opposing views will often have a cutting plane line showing the path of the cut. If the cutting plane in an assembly drawing passes through items that do not have internal voids, they should not be sectioned. Some of the items not usually sectioned are shafts, fasteners, rivets, keys, ribs, webs, and spokes. The following are standard types of sections.

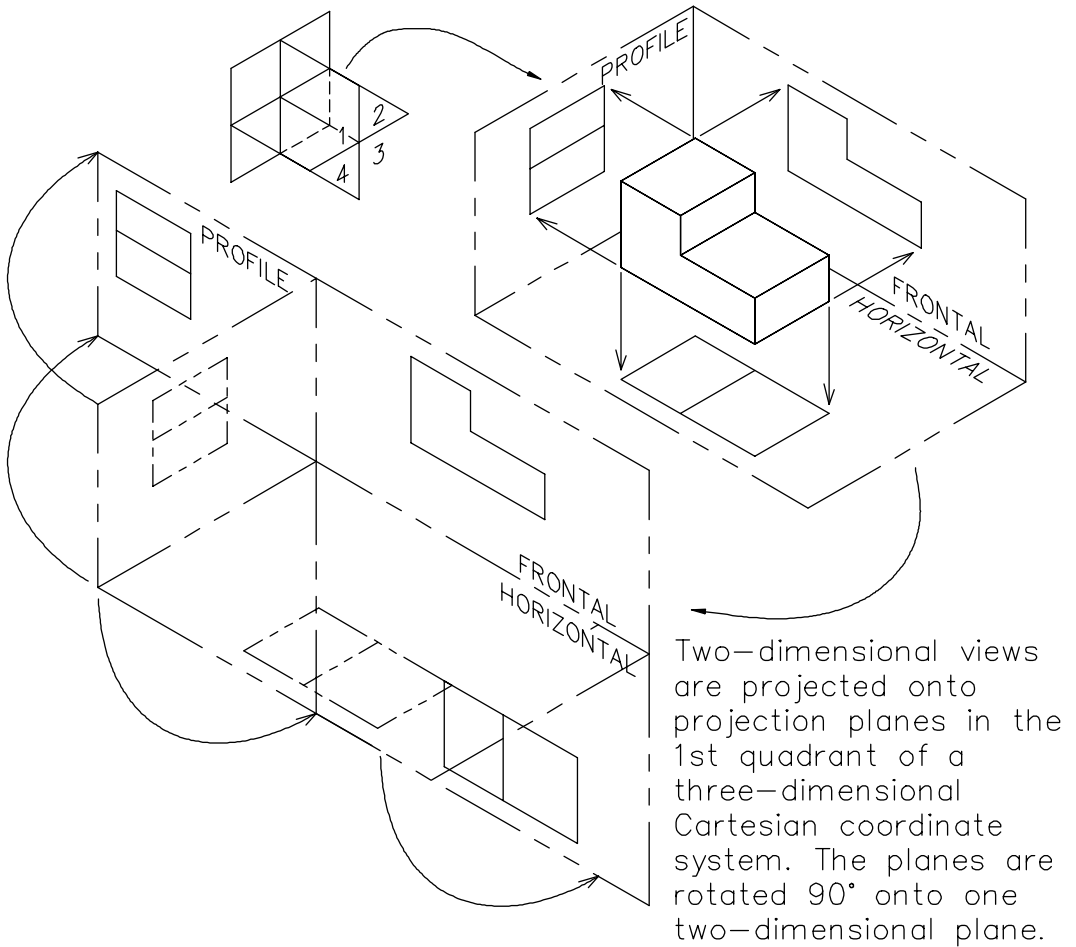

Orthographic Views

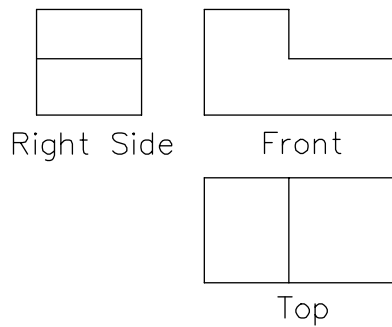
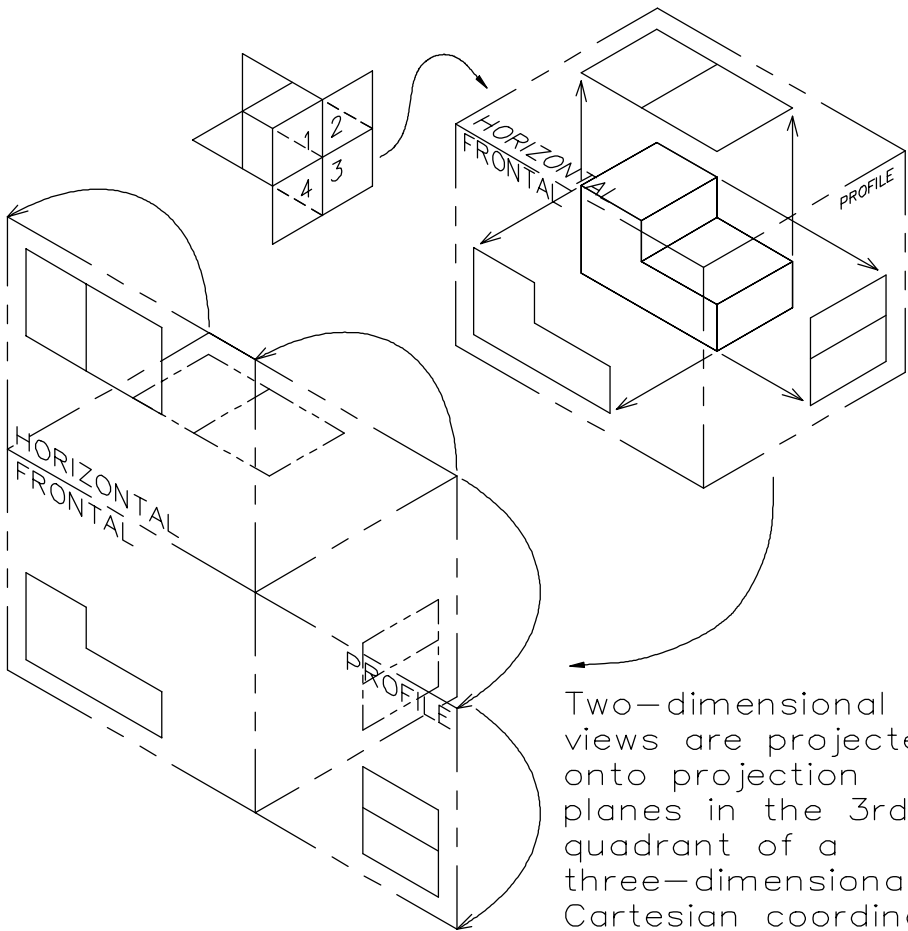
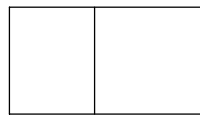

Figure 4-10 First-angle projection



Two-dimensional views are projected onto projection planes in the 3rd quadrant of a three-dimensional Cartesian coordinate system. The planes are rotated 90° onto one two-dimensional plane.

Orthographic Views



Top

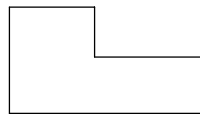

Front

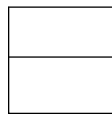

Right Side

Figure 4-11 Third-angle projection

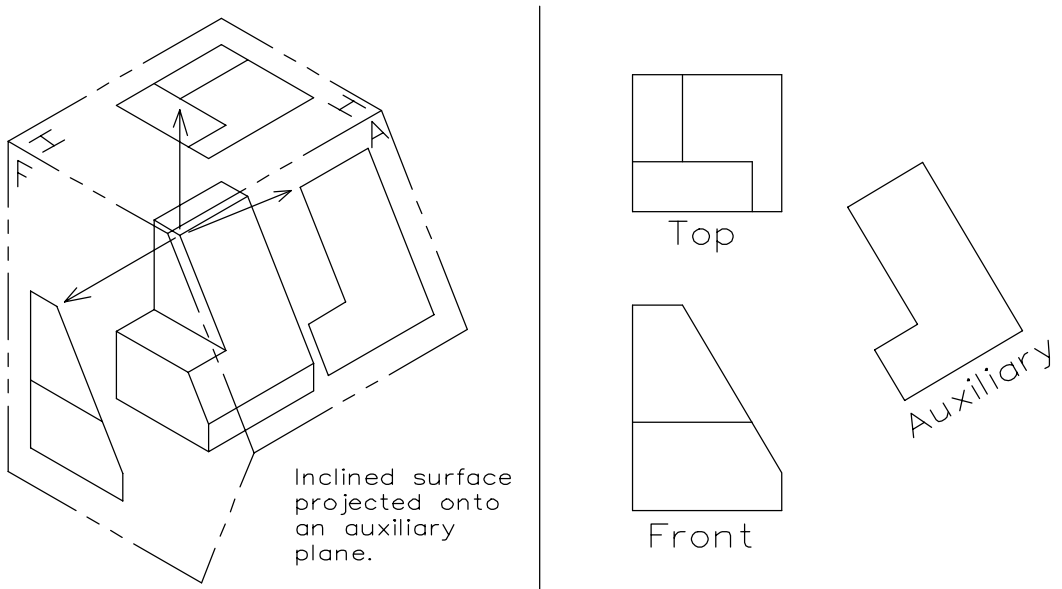

Figure 4-12 Auxiliary view development and arrangement

4.10.1 Full Sections

The view in full section appears to be cut fully from side to side. See Fig. 4-13. The cutting plane is one continuous plane with no offsets. If the location of the plane is obvious, it is not shown in an opposing view.

4.10.2 Half Sections

Half sections appear cut from one side to the middle of the part. See Fig. 4-14. In a half section, the side not in section does not show hidden lines. If the location of the plane is obvious, it is not shown in an opposing view.

4.10.3 Offset Sections

This type of sectioned view appears to be a full section, but when looking at the view where the section was taken, a cutting plane line will always show the direction of the cut through the part. See Fig. 4-15. The cutting plane changes direction to cut through the features of interest.

4.10.4 Broken-Out Section

The broken-out section of a view has the appearance of having been hit with a hammer to break a small part from the object. Rather than create a section through the entire part, only a localized portion of the object is sectioned. See Fig. 4-16.

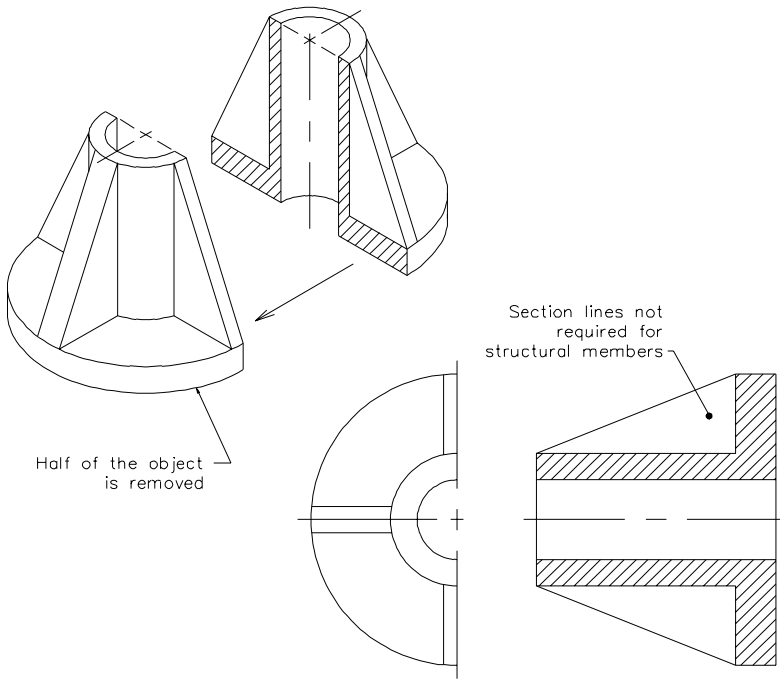

Figure 4-13 Full section

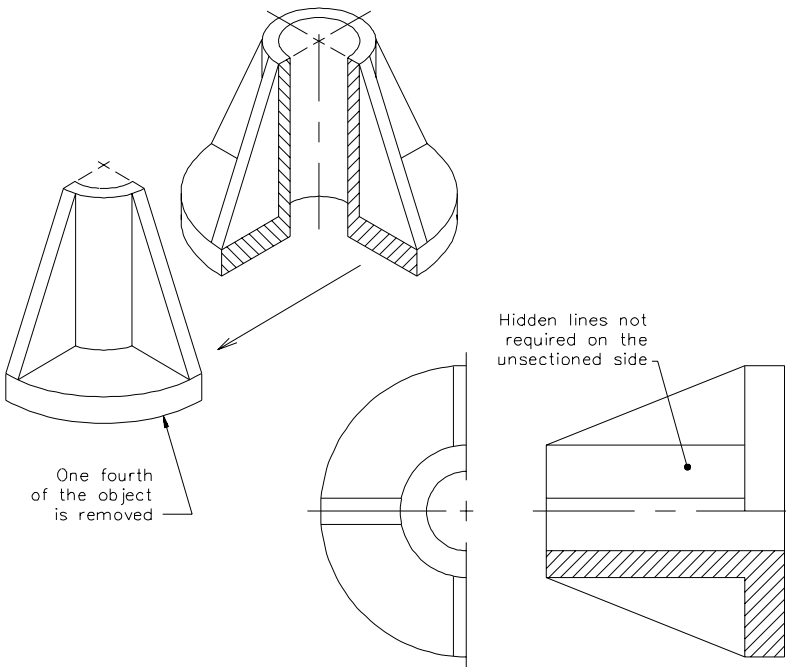

Figure 4-14 Half section

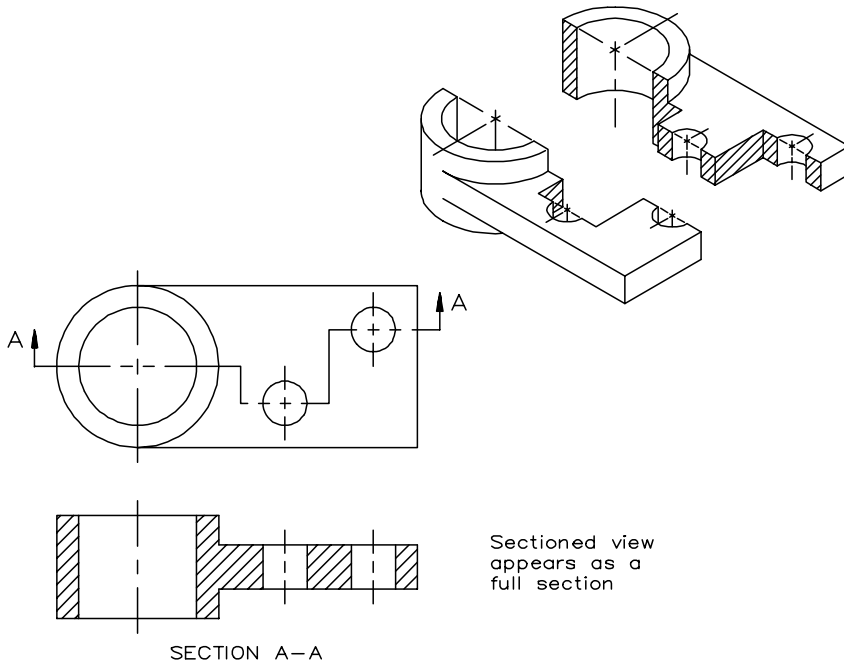

Figure 4-15 Offset section

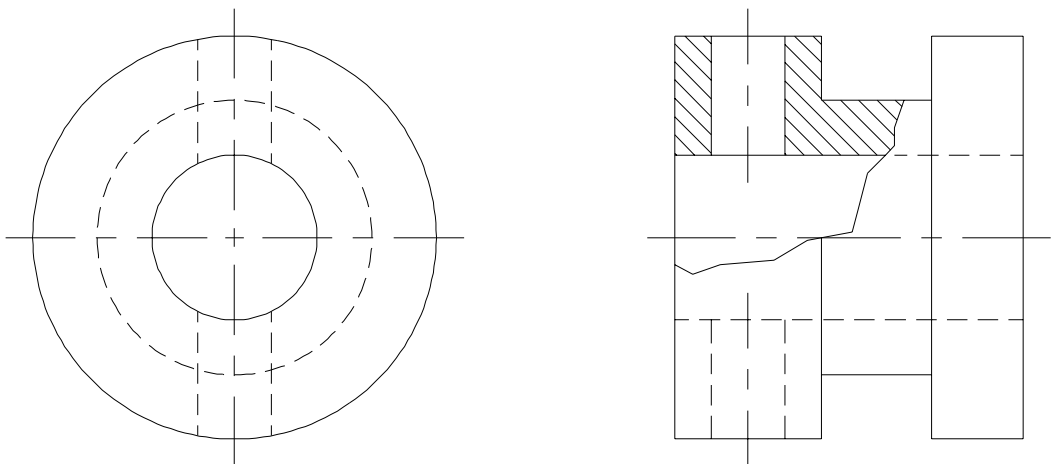

Figure 4-16 Broken-out section

4.10.5 Revolved and Removed Sections

The revolved and removed sections are developed in the same way. See Fig. 4-17. The concept is that a thin slice of an object is cut and rotated 90°. The section appears in the same view from where it was taken. The difference is the location of the sectioned view. The revolved view is placed at the point of revolution while the removed view is relocated to another more convenient location.

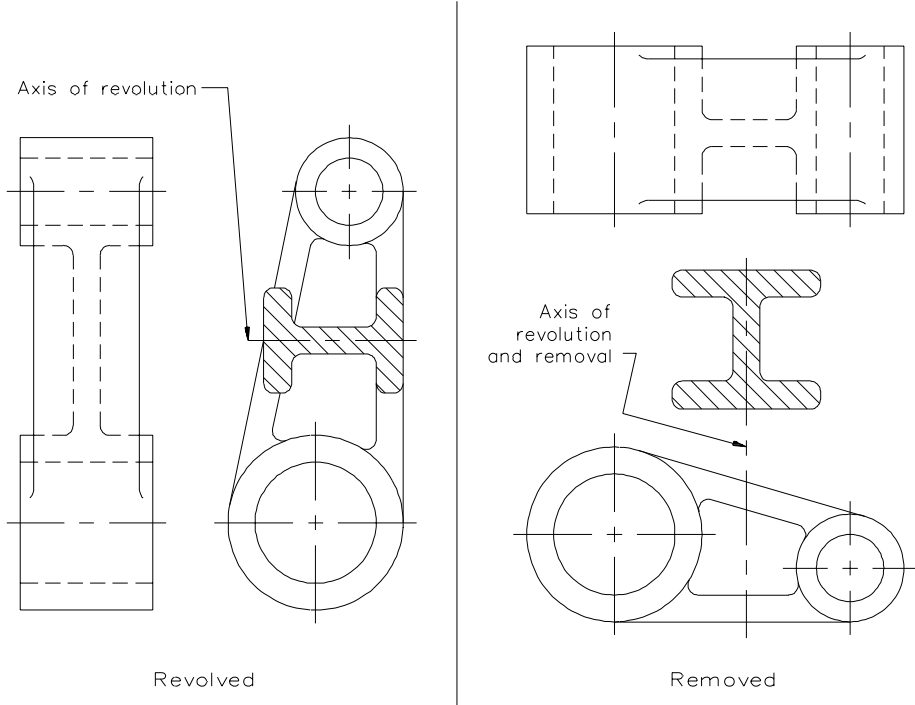

Figure 4-17 Revolved and removed section

4.10.6 Conventional Breaks

A conventional break is used to shorten a long consistent section length of material. See Fig. 4-18. There are conventional breaks for rods, bars, tubing, and woods.

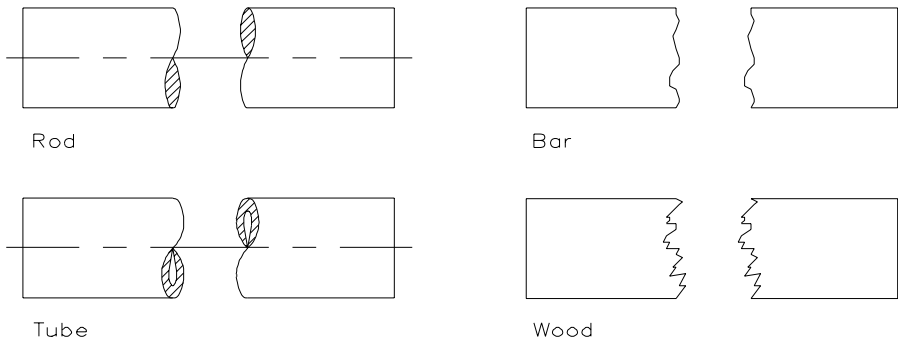

Figure 4-18 Conventional breaks

4.11 Partial Views

Partial views are regular views of an object with some lines missing. When it is confusing to show all the possible lines in any one view, some of the lines may be removed for clarity. See Fig. 4-19.

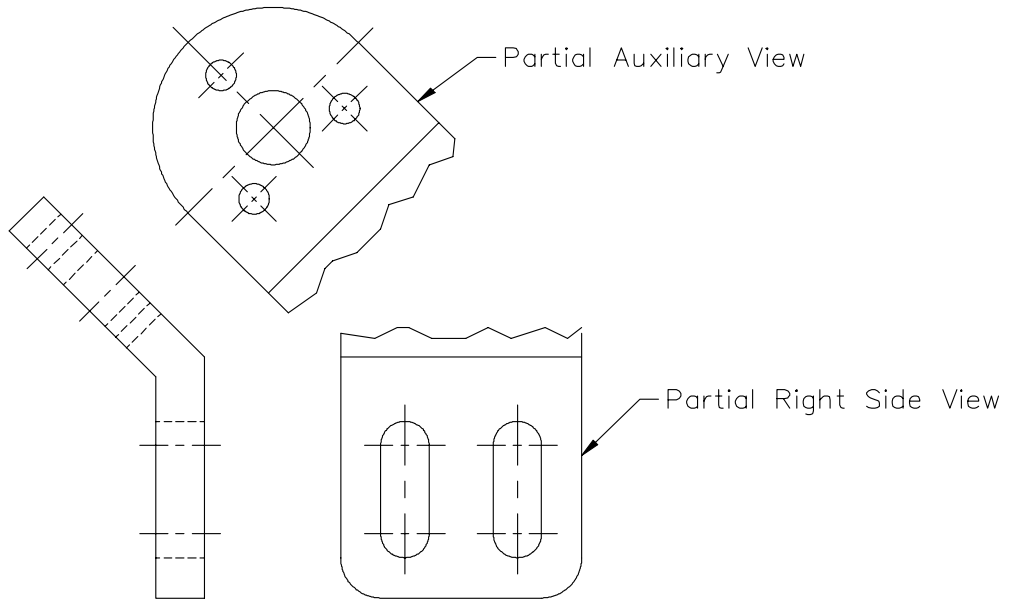

Figure 4-19 Partial views

4.12 Conventional Practices

It is not always practical to illustrate an object in its most correct projection. There are many occasions when altering the rules of orthographic projection is accepted. The following types of views represent common conventional practices.

4.12.1 Feature Rotation

Feature rotation is the practice of conceptually revolving features into positions that allow them to be viewed easily in an opposing view. For internal viewing, features may be rotated into a cutting plane. See Fig. 4-20. For external viewing, features may be rotated into a principal projection plane. This is often done to show the feature full size.

4.12.2 Line Precedence

When lines of different types occupy the same 2-D space, the lines are shown in the following order: object line, hidden line, cutting plane line, centerline, and phantom line.

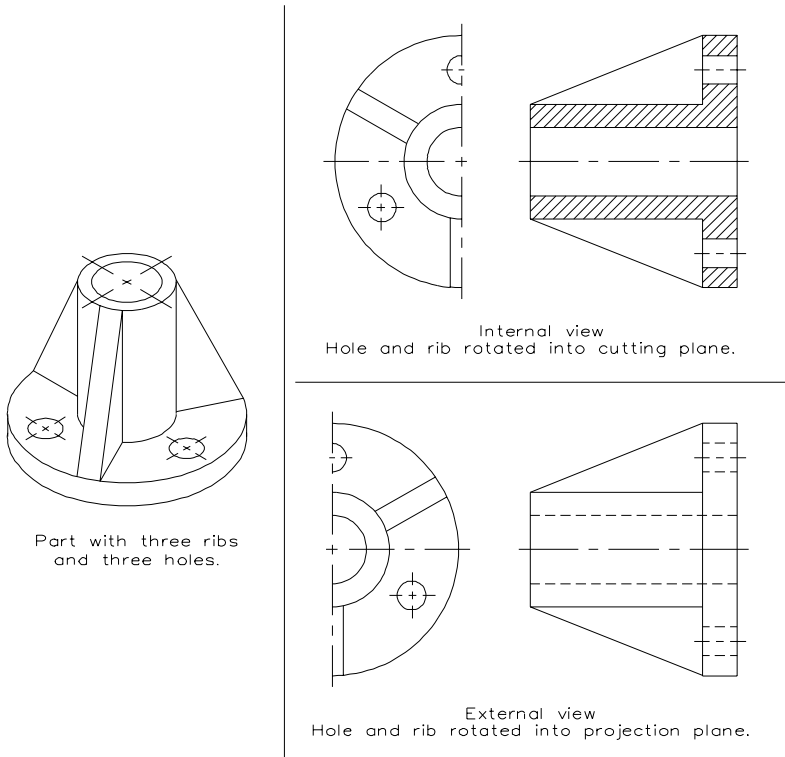

Figure 4-20 Internal and external feature rotation

4.13 Isometric Views

While many different methods may be used to show a pictorial view of a part, the isometric projection method is most common. To create an isometric projection, an object is rotated 45° in the top view then rotated $35^\circ 16'$ in the right side view. The resulting view appears 3-D. See Fig. 4-21. Fold line between the principal projection planes will measure 120° apart—hence, the name isometric or equal measures.

Companies that use 3-D computer programs to create part geometry may provide a 3-D view of the object along with conventional 2-D views. See Fig. 4-4. Some companies use 3-D views as their primary

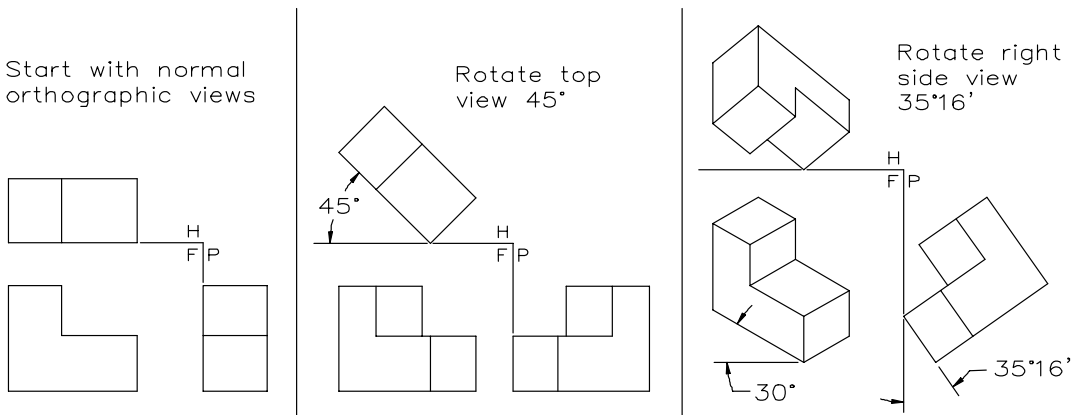

Figure 4-21 Isometric projection

view and 2-D views for sections. The object in Fig. 4-5 only shows critical size and geometric dimensioning. All other dimensions must be obtained from the computer database.

4.14 Dimensions

The role of the dimension on an engineering drawing has changed drastically for some companies. When dealing with traditional, manually created, 2-D drawings, the dimensions are the most important part of the drawing. The views are only a foundation for the dimensions. They could be quite inaccurate because the part is made from the dimensions and not the views.

When working with drawings created as a 3-D computer database, the geometry is most important. It must be created accurately because the computer database can be translated by another computer program into a language a machine tool can understand. In this scenario, the dimensions serve as a dimensional analysis tool and a reference document for inspection. See Chapter 16.

Dimensions may be of three different types: general dimensions, geometric dimensions, and surface texture. This section provides a brief introduction to general dimensioning and surface texture. Due to the extensive nature of geometric dimensioning, it is covered in Chapter 5. Prior to any discussion of dimensioning, the following underlying concepts must be understood.

4.14.1 Feature Types

Dimensions relate to features of parts. Features may be plane features, size features, or irregular features. A plane feature is considered nominally flat with a 2-D area. Size features are composed of two opposing surfaces like tabs and slots and surfaces with a constant radius like cylinders and spheres. Irregular features are free-form surfaces with defined undulations like the wing of an airplane or the outside surface of the hood of an automobile. Due to the nature of irregular surfaces, they are not usually defined only with general dimensions.

4.14.2 Taylor Principle / Envelope Principle

In 1905, an Englishman, William Taylor, was awarded the first patent for a full-form gage (GO-NOGO Gage) to inspect parts. His concept was that there is a space between the smallest size a feature can be and the largest size a feature can be and that all the surface elements must lie in that space. See Fig. 4-22.

A GO-NOGO gage is used to check the maximum and least material conditions of part features. The maximum material condition of a feature will make the part weigh more. The least material condition of a feature will make the part weigh less. Taylor's idea was to make a device that would reject a part whose form would exceed the maximum size of an external size feature or the minimum size of an internal size feature. For external size features, the device would be of two parallel plates separated by the maximum dimension for a tab or a largest sized hole for a shaft. For internal size features, the device would be two parallel plates at minimum separation for a slot or the smallest sized pin for a hole. See Chapter 19 for more information on gaging.

This idea was generally adopted by companies in the United States and was commonly known as the Taylor Principle. Product design uses a similar concept called the Envelope Principle. The Envelope Principle was adopted in the US because it unites the form of a feature with its 2-D size. It allows the allowance and maximum clearance to be calculated. Separate statements controlling the form of size features are not required.

The default condition adopted by the ISO is the Principle of Independency. This concept does not unite the form with the 2-D size of a feature—they are independent. If a form control is required, it must be stated. See Chapter 6 for the differences between the US and ISO standards.

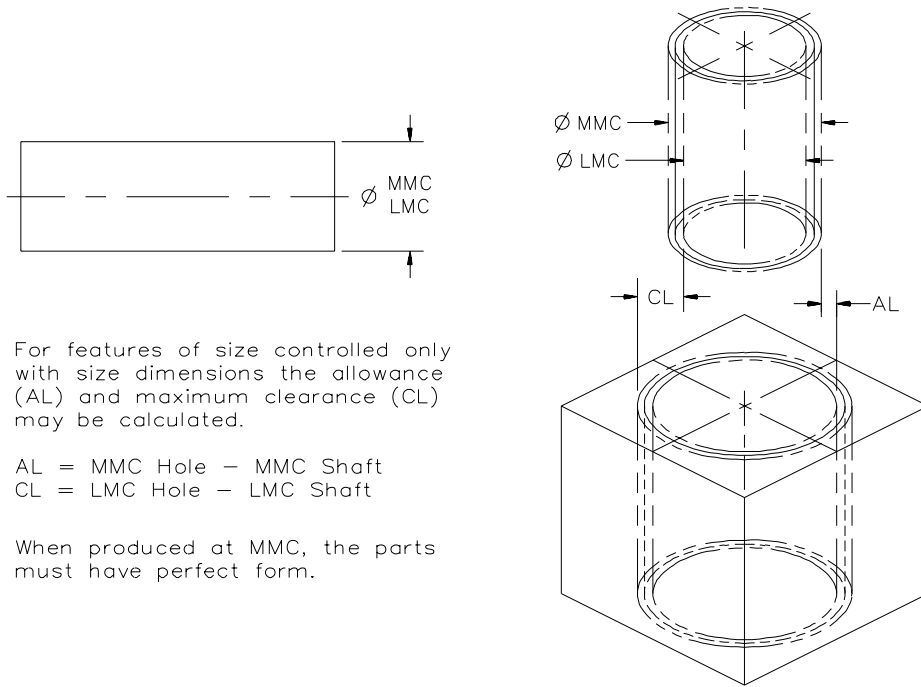

Figure 4-22 Envelope principle

4.14.3 General Dimensions

General dimensions provide size and location information. They can be classified with the names shown in Fig. 4-23.

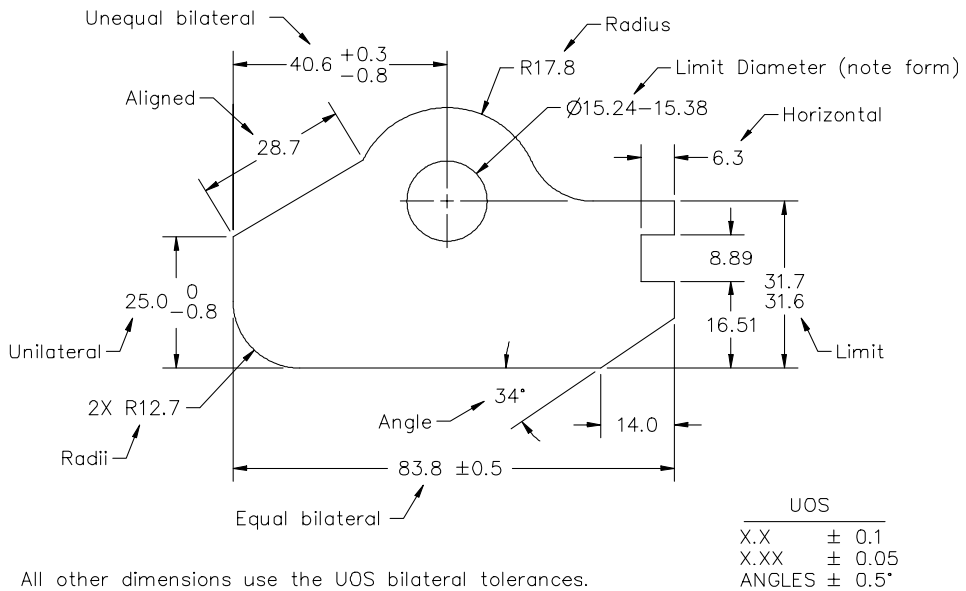

Figure 4-23 General dimension types

General dimensions have tolerances and, in the case of size features (in the US), conform to the Envelope Principle. They are most often placed on the drawing with dimension lines, dimension values, arrows, and leaders as shown on the left side of Fig. 4-24. Dimensions may be stated in a note, or the features can be coded with letters and the dimensions placed in a table in situations where there is not enough space to use extension lines and dimension lines.

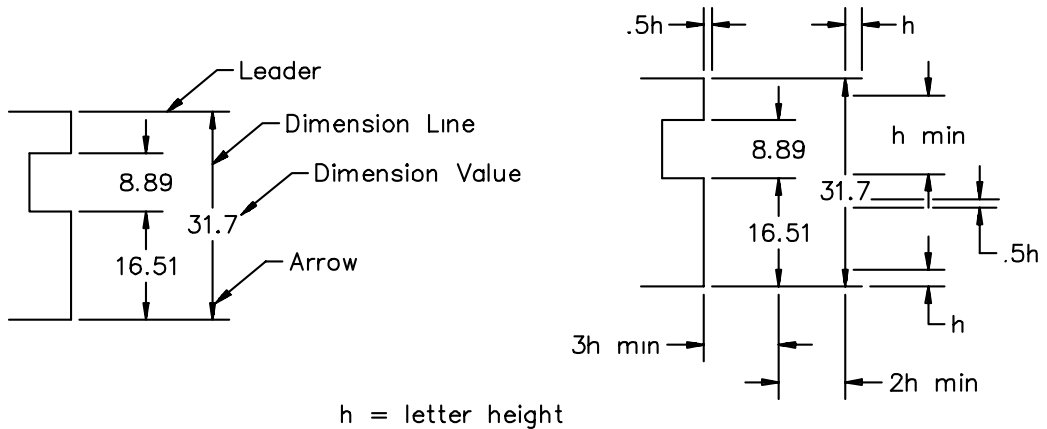

Figure 4-24 Dimension elements and measurements

4.14.4 Technique

Dimensioning techniques refer to the rudimentary details of arrow size, gap from the extension line to the object outline, length of the extension line past the dimension line, gap from the dimension line to the dimension value, and dimensioning symbols. The sizes shown on the right side of Fig. 4-24 are commonly used. Most computer aided drafting software will allow some or all of these elements to be adjusted to the letter height, as shown, or some other constant. Additional dimensioning symbols are shown in Chapter 5.

4.14.5 Placement

Whereas dimensioning techniques are fairly common from drawing to drawing and company to company, dimension placement can vary. It may be based on view arrangement, part contour, function, size, or simple convenience. Some common dimension placement examples are shown in Figs. 4-2, 4-3, 4-4, 4-23, and dimensioned in Fig. 4-24.

The most important element to good placement is consistent spacing. This translates to easy readability and fewer mistakes. Some other placement techniques are:

- Provide a minimum of 10 mm from the object outline to the first dimension line
- Provide a minimum of 6 mm between dimension lines
- Place shorter dimensions inside longer dimensions
- Avoid crossing dimension lines with extension lines or other dimension lines
- Dimension where the true size contour of the object is shown
- Place dimensions that apply to two views between the views
- Dimension the size and location of size features in the same view

4.14.6 Choice

There are usually several different ways to dimension an assembly and its detail parts. Making the best dimensional choices involves understanding many different areas. Knowledge of the requirements of the design should be the most important. Other knowledge areas should include the type and use of tooling fixtures, manufacturing procedures and capabilities, inspection techniques, assembly methods, and dimensional management policies and procedures. Many other areas like pricing control or part routing may also influence the dimensioning activity. Due to the vast body of knowledge required and legal implications of incorrect dimensioning practices, the dimensioning activity should be carefully considered, thoroughly executed, and cautiously checked. Depending on the complexity of the product, it may be prudent to assign a team of dimensional control engineers to perform this activity.

4.14.7 Tolerance Representation

All dimensions must have a tolerance associated with them. Six different methods of expressing toleranced dimension are presented in Fig. 4-23.

1. The 31.6-31.7 dimension is an example of the limit type—it shows the extreme size possibilities (the large number is always on top).
2. The 15.24-15.38 dimension is the same as the limit dimension but is presented in note form (the small number is written first and the numbers are separated by a dash).
3. The 83.8 dimension is an example of the equal bilateral form—the dimension is allowed to vary from nominal by an equal amount.
4. The 40.6 dimension is an example of the unequal bilateral form—the dimension is allowed to vary more in one direction than another.
5. The 25.0 dimension is an example of the unilateral form—the dimension is only allowed to vary in one direction from nominal.
6. The dimensions with only one number are actually equal bilateral dimensions that show the nominal dimension while the tolerance appears in the Unless Otherwise Specified (UOS) part of the title block.

4.15 Surface Texture

Surface texture symbols specify the limits on surface roughness, surface waviness, lay, and flaws. A machined surface may be compared to the ocean surface in that the ocean surface is composed of small ripples on larger waves. See Fig. 4-25. Basic surface texture symbols are used on the drawing shown in Fig. 4-3.

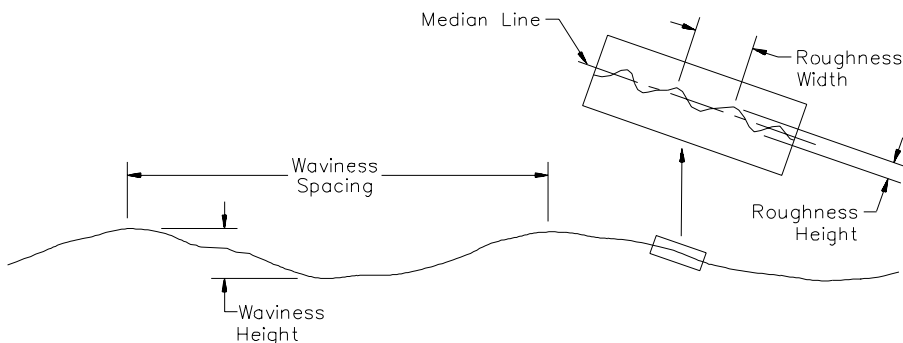

Figure 4-25 Surface characteristics

4.15.1 Roughness

The variability allowed for the small ripples on a surface is specified in micrometers or microinches. If only one number is given for the roughness average as shown in Fig. 4-26 (a) and (b), the measured values must be in a range between the stated number and 0. If two numbers are written one above the other as shown in example (c), the measured values must be within that range. Other roughness measures may be specified as shown in example (d).

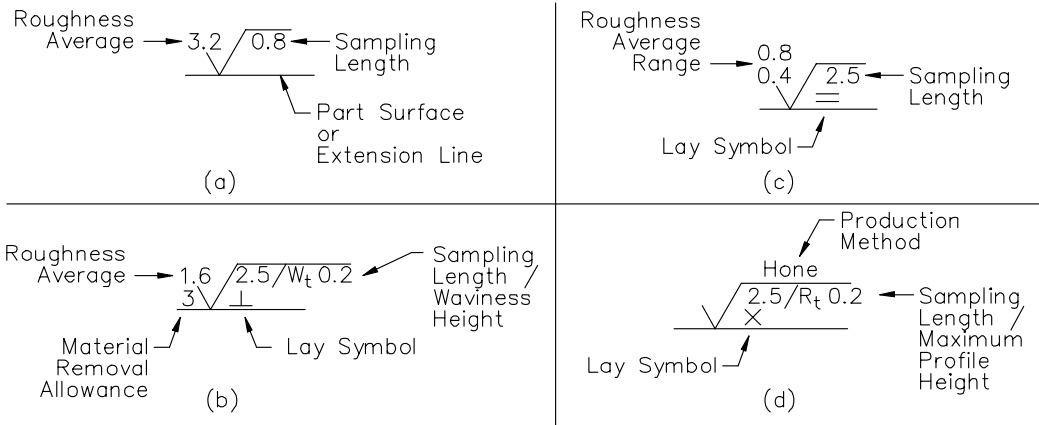

Figure 4-26 Surface texture examples and attributes

4.15.2 Waviness

The large waves are controlled by specifying the height (W_t) in millimeters. The placement of this parameter is shown in Fig. 4-26 (b).

4.15.3 Lay

The lay indicates the direction of the tool marks. See Fig. 4-26. Symbols or single letters are used to indicate perpendicular (b), parallel (c), crossed (d), multidirectional, circular, radial, particulate, nondirectional, or protuberant.

4.15.4 Flaws

Flaws are air pockets in the material that were exposed during production, scratches left by production or handling methods, or other nonintended surface irregularities. Flaw specifications are placed in the note section of the drawing.

4.16 Notes

Some information can be better stated in note form rather than in a dimension. See Fig. 4-2. Other information can *only* be stated in note form. Common notes specify default chamfer and radius values, information for plating or heat-treating, specific manufacturing operations, and many other pieces of information. Most companies group notes in one common location such as the upper left corner or to the left of the title block.

4.17 Drawing Status

The drawing life cycle may have several different stages. It may start as a sketch, progress to an experimental drawing, reach active status, and then be marked obsolete. Whatever their status, drawings require an accounting system to follow their changes in status. An engineering function, the data processing area, or a separate group may control this accounting system.

4.17.1 Sketch

A drawing often starts with a sketch of an assembly. From that sketch additional sketches may show interior parts and details of those parts. If the ideas seem worth the additional effort, the sketches may be transferred to formal detail and assembly drawings. Even though sketches may seem trivial at the time they are created, they should all be dated, signed, and stored for reference.

4.17.2 Configuration Layout

There may be different names for this type of drawing, but its main function is for analysis of geometric and dimensional details of an assembly. This activity has changed with the advent of computer simulations. Assemblies are built using 3-D digital models.

4.17.3 Experimental

Many ideas make the transition from sketches to experimental drawings. Parts made from these drawings may be tested and revised several times prior to being formally released as active production drawings.

4.17.4 Active

As the name implies, an active part drawing has gone through a formal release process. It will be released as any other drawing and, with good reason, should be accessible by any employee.

4.17.5 Obsolete

When a part is no longer sold, the drawing has reached the end of its life cycle. This does not mean a part could not be produced, but only that its status has changed to "Obsolete." Drawings are never destroyed. Drawings may be classified obsolete for production but retained for service, or obsolete for service but retained for production. If necessary, the drawing may be reactivated for production, service, or both.

4.18 Conclusion

With all the benefits realized by using a common drawing communication system, it is imperative that all personnel who deal with engineering drawings understand them completely. All the methods detailed in this chapter can be found in the appropriate standards. However, the standards covering this communication system are only guidelines. A company may choose to communicate their product specifications in different ways or to specify requirements not covered in the national standards. If this is the case, company-specific standards must be created and maintained.

4.19 References

1. The American Society of Mechanical Engineers. 1980. *ASME Y14.1-1980, Drawing Sheet Size and Format*. New York, New York: The American Society of Mechanical Engineers.
2. The American Society of Mechanical Engineers. 1995. *ASME B46.1-1995, Surface Texture (Surface Roughness, Waviness, and Lay)*. New York, New York: The American Society of Mechanical Engineers.
3. The American Society of Mechanical Engineers. 1992. *ASME Y14.2M-1992, Line Conventions and Lettering*. New York, New York: The American Society of Mechanical Engineers.
4. The American Society of Mechanical Engineers. 1994. *ASME Y14.3-1994, Multiview and Sectional View Drawings*. New York, New York: The American Society of Mechanical Engineers.
5. The American Society of Mechanical Engineers. 1995. *ASME Y14.5M-1994, Dimensioning and Tolerancing*. New York, New York: The American Society of Mechanical Engineers.
6. The American Society of Mechanical Engineers. 1996. *ASME Y14.8M-1996, Castings and Forgings*. New York, New York: The American Society of Mechanical Engineers.
7. The American Society of Mechanical Engineers. 1996. *ASME Y14.36M-1996, Surface Texture and Symbols*. New York, New York: The American Society of Mechanical Engineers.