

CHAPTER 10

STRESS ANALYSIS

Franklin E. Fisher
Mechanical Engineering Department
Loyola Marymount University
Los Angeles, California
and
Senior Staff Engineer
Hughes Aircraft Company (Retired)

10.1 STRESSES, STRAINS, STRESS INTENSITY	191	10.8 COLUMNS	229
10.1.1 Fundamental Definitions	191	10.8.1 Definitions	229
10.1.2 Work and Resilience	197	10.8.2 Theory	230
10.2 DISCONTINUITIES, STRESS CONCENTRATION	199	10.8.3 Wooden Columns	232
10.3 COMBINED STRESSES	199	10.8.4 Steel Columns	232
10.4 CREEP	203	10.9 CYLINDERS, SPHERES, AND PLATES	235
10.5 FATIGUE	205	10.9.1 Thin Cylinders and Spheres under Internal Pressure	235
10.5.1 Modes of Failure	206	10.9.2 Thick Cylinders and Spheres	235
10.6 BEAMS	207	10.9.3 Plates	237
10.6.1 Theory of Flexure	207	10.9.4 Trunnion	237
10.6.2 Design of Beams	212	10.9.5 Socket Action	237
10.6.3 Continuous Beams	217	10.10 CONTACT STRESSES	242
10.6.4 Curved Beams	220	10.11 ROTATING ELEMENTS	244
10.6.5 Impact Stresses in Bars and Beams	220	10.11.1 Shafts	244
10.6.6 Steady and Impulsive Vibratory Stresses	224	10.11.2 Disks	244
10.7 SHAFTS, BENDING, AND TORSION	224	10.11.3 Blades	244
10.7.1 Definitions	224	10.12 DESIGN SOLUTION SOURCES AND GUIDELINES	244
10.7.2 Determination of Torsional Stresses in Shafts	225	10.12.1 Computers	244
10.7.3 Bending and Torsional Stresses	229	10.12.2 Testing	245

10.1 STRESSES, STRAINS, STRESS INTENSITY

10.1.1 Fundamental Definitions

Static Stresses

TOTAL STRESS on a section mn through a loaded body is the resultant force S exerted by one part of the body on the other part in order to maintain in equilibrium the external loads acting on the

Revised from Chapter 8, *Kent's Mechanical Engineer's Handbook*, 12th ed., by John M. Lessells and G. S. Cherniak.

Mechanical Engineers' Handbook, 2nd ed., Edited by Myer Kutz.
ISBN 0-471-13007-9 © 1998 John Wiley & Sons, Inc.

part. Thus, in Figs. 10.1, 10.2, and 10.3 the total stress on section mn due to the external load P is S . The units in which it is expressed are those of load, that is, pounds, tons, etc.

UNIT STRESS more commonly called stress σ , is the total stress per unit of area at section mn . In general it varies from point to point over the section. Its value at any point of a section is the total stress on an elementary part of the area, including the point divided by the elementary total stress on an elementary part of the area, including the point divided by the elementary area. If in Figs 10.1, 10.2, and 10.3 the loaded bodies are one unit thick and four units wide, then when the total stress S is uniformly distributed over the area, $\sigma = P/A = P/4$. Unit stresses are expressed in pounds per square inch, tons per square foot, etc.

TENSILE STRESS OR TENSION is the internal total stress S exerted by the material fibers to resist the action of an external force P (Fig. 10.1), tending to separate the material into two parts along the line mn . For equilibrium conditions to exist, the tensile stress at any cross section will be equal and opposite in direction to the external force P . If the internal total stress S is distributed uniformly over the area, the stress can be considered as unit tensile stress $\sigma = S/A$.

COMPRESSIVE STRESS OR COMPRESSION is the internal total stress S exerted by the fibers to resist the action of an external force P (Fig. 10.2) tending to decrease the length of the material. For equilibrium conditions to exist, the compressive stress at any cross section will be equal and opposite in direction to the external force P . If the internal total stress S is distributed uniformly over the area, the unit compressive stress $\sigma = S/A$.

SHEAR STRESS is the internal total stress S exerted by the material fibers along the plane mn (Fig. 10.3) to resist the action of the external forces, tending to slide the adjacent parts in opposite directions. For equilibrium conditions to exist, the shear stress at any cross section will be equal and opposite in direction to the external force P . If the internal total stress S is uniformly distributed over the area, the unit shear stress $\tau = S/A$.

NORMAL STRESS is the component of the resultant stress that acts normal to the area considered (Fig. 10.4).

AXIAL STRESS is a special case of normal stress and may be either tensile or compressive. It is the stress existing in a straight homogeneous bar when the resultant of the applied loads coincides with the axis of the bar.

SIMPLE STRESS exists when either tension, compression, or shear is considered to operate singly on a body.

TOTAL STRAIN on a loaded body is the total elongation produced by the influence of an external load. Thus, in Fig. 10.4, the total strain is equal to δ . It is expressed in units of length, that is, inches, feet, etc.

UNIT STRAIN or deformation per unit length is the total amount of deformation divided by the original length of the body before the load causing the strain was applied. Thus, if the total elongation is δ in an original gage length l , the unit strain $e = \delta/l$. Unit strains are expressed in inches per inch and feet per foot.

TENSILE STRAIN is the strain produced in a specimen by tensile stresses, which in turn are caused by external forces.

COMPRESSIVE STRAIN is the strain produced in a bar by compressive stresses, which in turn are caused by external forces.

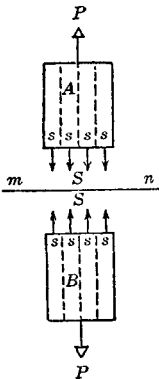

Fig. 10.1 Tensile stress.

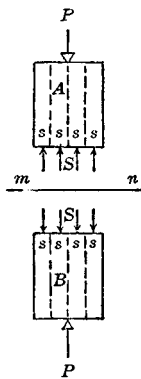

Fig. 10.2 Compressive stress.

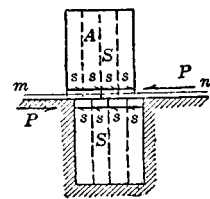

Fig. 10.3 Shear stress.

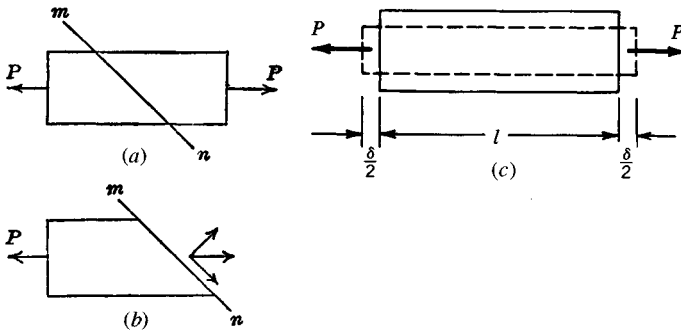

Fig. 10.4 Normal and shear stress components of resultant stress on section *mn* and strain due to tension.

SHEAR STRAIN is a strain produced in a bar by the external shearing forces.

POISSON'S RATIO is the ratio of lateral unit strain to longitudinal unit strain under the conditions of uniform and uniaxial longitudinal stress within the proportional limit. It serves as a measure of lateral stiffness. Average values of Poisson's ratio for the usual materials of construction are:

Material	Steel	Wrought Iron	Cast Iron	Brass	Concrete
Poisson's ratio	0.300	0.280	0.270	0.340	0.100

ELASTICITY is that property of a material that enables it to deform or undergo strain and return to its original shape upon the removal of the load.

HOOKE'S LAW states that within certain limits (not to exceed the proportional limit) the elongation of a bar produced by an external force is proportional to the tensile stress developed. Hooke's law gives the simplest relation between stress and strain.

PLASTICITY is that state of matter where permanent deformations or strains may occur without fracture. A material is plastic if the smallest load increment produces a permanent deformation. A perfectly plastic material is nonelastic and has no ultimate strength in the ordinary meaning of that term. Lead is a plastic material. A prism tested in compression will deform permanently under a small load and will continue to deform as the load is increased, until it flattens to a thin sheet. Wrought iron and steel are plastic when stressed beyond the elastic limit in compression. When stressed beyond the elastic limit in tension, they are partly elastic and partly plastic, the degree of plasticity increasing as the ultimate strength is approached.

STRESS-STRAIN RELATIONSHIP gives the relation between unit stress and unit strain when plotted on a stress-strain diagram in which the ordinate represents unit stress and the abscissa represents unit strain. Figure 10.5 shows a typical tension stress-strain curve for medium steel. The form of the curve obtained will vary according to the material, and the curve for compression will be different from the one for tension. For some materials like cast iron, concrete, and timber, no part of the curve is a straight line.

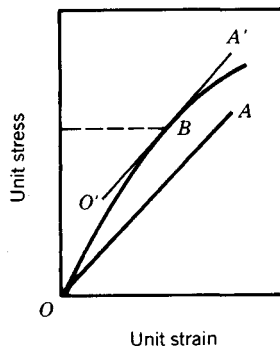

Fig. 10.5 Stress-strain relationship showing determination of apparent elastic limit.

PROPORTIONAL LIMIT is that unit stress at which unit strain begins to increase at a faster rate than unit stress. It can also be thought of as the greatest stress that a material can stand without deviating from Hooke's law. It is determined by noting on a stress-strain diagram the unit stress at which the curve departs from a straight line.

ELASTIC LIMIT is the least stress that will cause permanent strain, that is, the maximum unit stress to which a material may be subjected and still be able to return to its original form upon removal of the stress.

JOHNSON'S APPARENT ELASTIC LIMIT. In view of the difficulty of determining precisely for some materials the proportional limit, J. B. Johnson proposed as the "apparent elastic limit" the point on the stress-strain diagram at which the rate of strain is 50% greater than at the original. It is determined by drawing OA (Fig. 10.5) with a slope with respect to the vertical axis 50% greater than the straight-line part of the curve; the unit stress at which the line $O'A'$ which is parallel to OA is tangent to the curve (point B , Fig. 10.5) is the apparent elastic limit.

YIELD POINT is the lowest stress at which strain increases without increase in stress. Only a few materials exhibit a true yield point. For other materials the term is sometimes used as synonymous with yield strength.

YIELD STRENGTH is the unit stress at which a material exhibits a specified permanent deformation or state. It is a measure of the useful limit of materials, particularly of those whose stress-strain curve in the region of yield is smooth and gradually curved.

ULTIMATE STRENGTH is the highest unit stress a material can sustain in tension, compression, or shear before rupturing.

RUPTURE STRENGTH OR BREAKING STRENGTH is the unit stress at which a material breaks or ruptures. It is observed in tests on steel to be slightly less than the ultimate strength because of a large reduction in area before rupture.

MODULUS OF ELASTICITY (Young's modulus) in tension and compression is the rate of change of unit stress with respect to unit strain for the condition of uniaxial stress within the proportional limit. For most materials the modulus of elasticity is the same for tension and compression.

MODULUS OF RIGIDITY (modulus of elasticity in shear) is the rate of change of unit shear stress with respect to unit shear strain for the condition of pure shear within the proportional limit. For metals it is equal to approximately 0.4 of the modulus of elasticity.

TRUE STRESS is defined as a ratio of applied axial load to the corresponding cross-sectional area. The units of true stress may be expressed in pounds per square inch, pounds per square foot, etc.,

$$\sigma = \frac{P}{A}$$

where σ is the true stress, pounds per square inch, P is the axial load, pounds, and A is the smallest value of cross-sectional area existing under the applied load P , square inches.

TRUE STRAIN is defined as a function of the original diameter to the instantaneous diameter of the test specimen:

$$q = 2 \log_e \frac{d_0}{d} \text{ in./in.}$$

where q = true strain, inches per inch, d_0 = original diameter of test specimen, inches, and d = instantaneous diameter of test specimen, inches.

TRUE STRESS-STRAIN RELATIONSHIP is obtained when the values of true stress and the corresponding true strain are plotted against each other in the resulting curve (Fig. 10.6). The slope of the nearly straight line leading up to fracture is known as the coefficient of strain hardening. It as well as the true tensile strength appear to be related to the other mechanical properties.

DUCTILITY is the ability of a material to sustain large permanent deformations in tension, such as drawing into a wire.

MALLEABILITY is the ability of a material to sustain large permanent deformations in compression, such as beating or rolling into thin sheets.

BRITTLINESS is that property of a material that permits it to be only slightly deformed without rupture. Brittleness is relative, no material being perfectly brittle, that is, capable of no deformation before rupture. Many materials are brittle to a greater or less degree, glass being one of the most brittle of materials. Brittle materials have relatively short stress-strain curves. Of the common structural materials, cast iron, brick, and stone are brittle in comparison with steel.

TOUGHNESS is the ability of the material to withstand high unit stress together with great unit strain, without complete fracture. The area $OAGH$, or OJK , under the curve of the stress-strain diagram

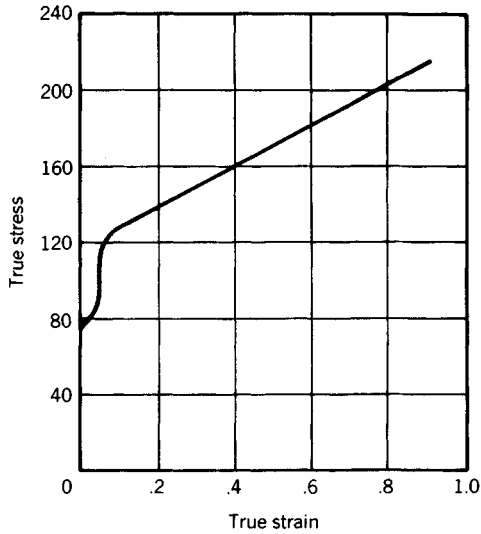

Fig. 10.6 True stress-strain relationship.

(Fig. 10.7), is a measure of the toughness of the material. The distinction between ductility and toughness is that ductility deals only with the ability to deform, whereas toughness considers both the ability to deform and the stress developed during deformation.

STIFFNESS is the ability to resist deformation under stress. The modulus of elasticity is the criterion of the stiffness of a material.

HARDNESS is the ability to resist very small indentations, abrasion, and plastic deformation. There is no single measure of hardness, as it is not a single property but a combination of several properties.

CREEP or flow of metals is a phase of plastic or inelastic action. Some solids, as asphalt or paraffin, flow appreciably at room temperatures under extremely small stresses; zinc, plastics, fiber-reinforced plastics, lead, and tin show signs of creep at room temperature under moderate stresses. At sufficiently high temperatures, practically all metals creep under stresses that vary with temperature, the higher the temperature the lower being the stress at which creep takes place. The deformation due to creep continues to increase indefinitely and becomes of extreme importance in members subjected to high temperatures, as parts in turbines, boilers, super-heaters, etc.

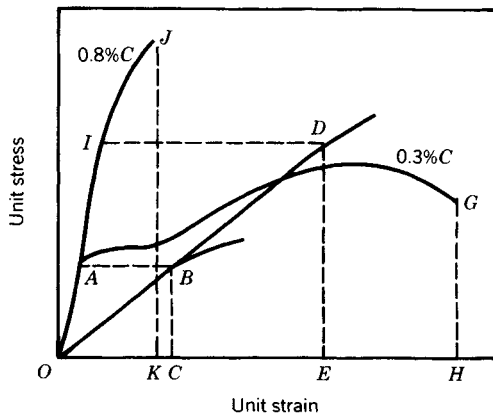

Fig. 10.7 Toughness comparison.

Creep limit is the maximum unit stress under which unit distortion will not exceed a specified value during a given period of time at a specified temperature. A value much used in tests, and suggested as a standard for comparing materials; is the maximum unit stress at which creep does not exceed 1% in 100,000 hours.

TYPES OF FRACTURE. A bar of brittle material, such as cast iron, will rupture in a tension test in a clean sharp fracture with very little reduction of cross-sectional area and very little elongation (Fig. 10.8a). In a ductile material, as structural steel, the reduction of area and elongation are greater (Fig. 10.8b). In compression, a prism of brittle material will break by shearing along oblique planes; the greater the brittleness of the material, the more nearly will these planes parallel the direction of the applied force. Figures 10.8c, 10.8d, and 10.8e, arranged in order of brittleness, illustrate the type of fracture in prisms of brick, concrete, and timber. Figure 10.8f represents the deformation of a prism of plastic material, as lead, which flattens out under load without failure.

RELATIONS OF ELASTIC CONSTANTS

Modulus of elasticity, E :

$$E = \frac{Pl}{Ae}$$

where P = load, pounds, l = length of bar, inches, A = cross-sectional area acted on by the axial load, P , and e = total strain produced by axial load P .

Modulus of rigidity, G :

$$G = \frac{E}{2(1 + \nu)}$$

where E = modulus of elasticity and ν = Poisson's ratio.

Bulk modulus, K , is the ratio of normal stress to the change in volume.

Relationships. The following relationships exist between the modulus of elasticity E , the modulus of rigidity G , the bulk modulus of elasticity K , and Poisson's ratio ν :

$$E = 2G(1 + \nu); \quad G = \frac{E}{2(1 + \nu)}; \quad \nu = \frac{E - 2G}{2G}$$

$$K = \frac{E}{3(1 - 2\nu)}; \quad \nu = \frac{3K - E}{6K}$$

ALLOWABLE UNIT STRESS, also called allowable working unit stress, allowable stress, or working stress, is the maximum unit stress to which it is considered safe to subject a member in service. The term allowable stress is preferable to working stress, since the latter often is used to indicate the actual stress in a material when in service. Allowable unit stresses for different materials for various conditions of service are specified by different authorities on the basis of test or experience. In general, for ductile materials, allowable stress is considerably less than the yield point.

FACTOR OF SAFETY is the ratio of ultimate strength of the material to allowable stress. The term was originated for determining allowable stress. The ultimate strength of a given material divided by an arbitrary factor of safety, dependent on material and the use to which it is to be put, gives

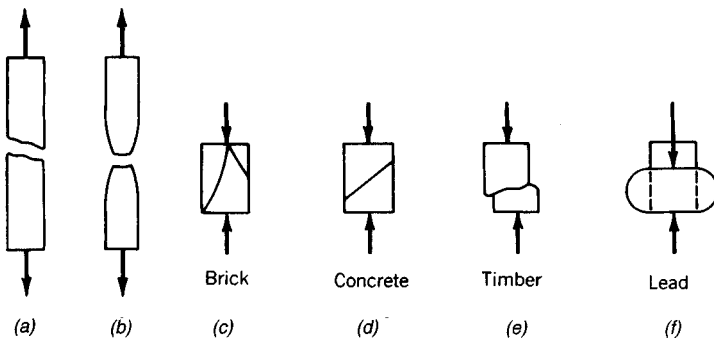

Fig. 10.8 (a) Brittle and (b) ductile fractures in tension and compression fractures.

the allowable stress. In present design practice, it is customary to use allowable stress as specified by recognized authorities or building codes rather than an arbitrary factor of safety. One reason for this is that the factor of safety is misleading, in that it implies a greater degree of safety than actually exists. For example, a factor of safety of 4 does not mean that a member can carry a load four times as great as that for which it was designed. It also should be clearly understood that, even though each part of a machine is designed with the same factor of safety, the machine as a whole does not have that factor of safety. When one part is stressed beyond the proportional limit, or particularly the yield point, the load or stress distribution may be completely changed throughout the entire machine or structure, and its ability to function thus may be changed, even though no part has ruptured.

Although no definite rules can be given, if a factor of safety is to be used, the following circumstances should be taken into account in its selection:

1. When the ultimate strength of the material is known within narrow limits, as for structural steel for which tests of samples have been made, when the load is entirely a steady one of a known amount and there is no reason to fear the deterioration of the metal by corrosion, the lowest factor that should be adopted is 3.
2. When the circumstances of (1) are modified by a portion of the load being variable, as in floors of warehouses, the factor should not be less than 4.
3. When the whole load, or nearly the whole, is likely to be alternately put on and taken off, as in suspension rods of floors of bridges, the factor should be 5 or 6.
4. When the stresses are reversed in direction from tension to compression, as in some bridge diagonals and parts of machines, the factor should be not less than 6.
5. When the piece is subjected to repeated shocks, the factor should be not less than 10.
6. When the piece is subjected to deterioration from corrosion, the section should be sufficiently increased to allow for a definite amount of corrosion before the piece is so far weakened by it as to require removal.
7. When the strength of the material or the amount of the load or both are uncertain, the factor should be increased by an allowance sufficient to cover the amount of the uncertainty.
8. When the strains are complex and of uncertain amount, such as those in the crankshaft of a reversing engine, a very high factor is necessary, possibly even as high as 40.
9. If the property loss caused by failure of the part may be large or if loss of life may result, as in a derrick hoisting materials over a crowded street, the factor should be large.

Dynamic Stresses

DYNAMIC STRESSES occur where the dimension of time is necessary in defining the loads. They include creep, fatigue, and impact stresses.

CREEP STRESSES occur when either the load or deformation progressively vary with time. They are usually associated with noncyclic phenomena.

FATIGUE STRESSES occur when type cyclic variation of either load or strain is coincident with respect to time.

IMPACT STRESSES occur from loads which are transient with time. The duration of the load application is of the same order of magnitude as the natural period of vibration of the specimen.

10.1.2 Work and Resilience

EXTERNAL WORK. Let P = axial load, pounds, on a bar, producing an internal stress not exceeding the elastic limit; σ = unit stress produced by P , pounds per square inch; A = cross-sectional area, square inches; l = length of bar, inches; e = deformation, inches; E = modulus of elasticity; W = external work performed on bar, inch-pounds = $\frac{1}{2}Pe$. Then

$$W = \frac{1}{2} A \sigma \left(\frac{\sigma l}{E} \right) = \frac{1}{2} \left(\frac{\sigma^2}{E} \right) Al \quad (10.1)$$

The factor $\frac{1}{2}(\sigma^2/E)$ is the work required per unit volume, the volume being Al . It is represented on the stress-strain diagram by the area ODE or area OBC (Fig. 10.9), which DE and BC are ordinates representing the unit stresses considered.

RESILIENCE is the strain energy that may be recovered from a deformed body when the load causing the stress is removed. Within the proportional limit, the resilience is equal to the external work performed in deforming the bar, and may be determined by Eq. (10.1). When σ is equal to the proportional limit, the factor $\frac{1}{2}(\sigma^2/E)$ is the *modulus of resilience*, that is, the measure of capacity of a unit volume of material to store strain energy up to the proportional limit. Average values of

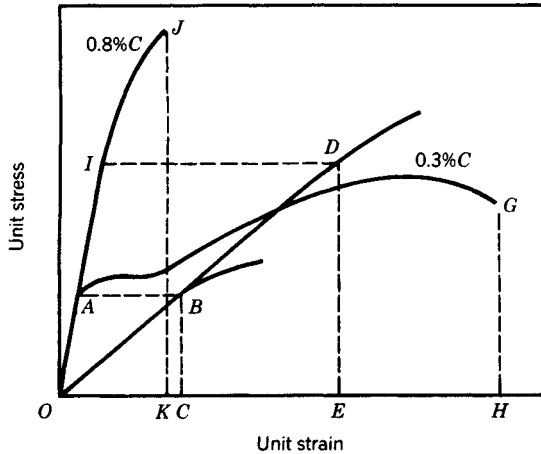

Fig. 10.9 Work areas on stress-strain diagram.

the modulus of resilience under tensile stress are given in Table 10.1.

The total resilience of a bar is the product of its volume and the modulus of resilience. These formulas for work performed on a bar, and its resilience, do not apply if the unit stress is greater than the proportional limit.

WORK REQUIRED FOR RUPTURE. Since beyond the proportional limit the strains are not proportional to the stresses, $\frac{1}{2}P$ does not express the mean value of the force acting. Equation (10.1), therefore, does not express the work required for strain after the proportional limit of the material has been passed, and cannot express the work required for rupture. The work required per unit volume to produce strains beyond the proportional limit or to cause rupture may be determined from the stress-strain diagram as it is measured by the area under the stress-strain curve up to the strain in question, as $OAGH$ or OJK (Fig. 10.9). This area, however, does not represent the resilience, since part of the work done on the bar is present in the form of hysteresis losses and cannot be recovered.

DAMPING CAPACITY (HYSTERESIS). Observations show that when a tensile load is applied to a bar, it does not produce the complete elongation immediately, but there is a definite time lapse which

Table 10.1 Modulus of Resilience and Relative Toughness under Tensile Stress (Avg. Values)

Material	Modulus of Resilience (in.-lb/in. ³)	Relative Toughness (Area under Curve of Stress-Deformation Diagram)
Gray cast iron	1.2	70
Malleable cast iron	17.4	-3,800
Wrought iron	11.6	11,000
Low-carbon steel	15.0	15,700
Medium-carbon steel	34.0	16,300
High-carbon steel	94.0	5,000
Ni-Cr steel, hot-rolled	94.0	44,000
Vanadium steel, 0.98% C, 0.2% V, heat-treated	260.0	22,000
Duralumin, 17 ST	45.0	10,000
Rolled bronze	57.0	15,500
Rolled brass	40.0	10,000
Oak	2.3 ^a	13 ^a

^aBending.

depends on the nature of the material and the magnitude of the stresses involved. In parallel with this it is also noted that, upon unloading, complete recovery of energy does not occur. This phenomenon is variously termed *elastic hysteresis* or, for vibratory stresses, damping. Figure 10.10 shows a typical hysteresis loop obtained for one cycle of loading. The area of this hysteresis loop, representing the energy dissipated per cycle, is a measure of the damping properties of the material. While the exact mechanism of damping has not been fully investigated, it has been found that under vibratory conditions the energy dissipated in this manner varies approximately as the cube of the stress.

10.2 DISCONTINUITIES, STRESS CONCENTRATION

The direct design procedure assumes no abrupt changes in cross-section, discontinuities in the surface, or holes, through the member. In most structural parts this is not the case. The stresses produced at these discontinuities are different in magnitude from those calculated by various design methods. The effect of the localized increase in stress, such as that caused by a notch, fillet, hole, or similar *stress raiser*, depends mainly on the type of loading, the geometry of the part, and the material. As a result, it is necessary to consider a stress-concentration factor K_t , which is defined by the relationship

$$K_t = \frac{\sigma_{\max}}{\sigma_{\text{nominal}}} \quad (10.2)$$

In general σ_{\max} will have to be determined by the methods of experimental stress analysis or the theory of elasticity, and σ_{nominal} by a simple theory such as $\sigma = P/A$, $\sigma = Mc/I$, $\tau = Tc/J$ without taking into account the variations in stress conditions caused by geometrical discontinuities such as holes, grooves, and fillets. For ductile materials it is not customary to apply stress-concentration factors to members under static loading. For brittle materials, however, stress concentration is serious and should be considered.

Stress-Concentration Factors for Fillets, Keyways, Holes, and Shafts

In Table 10.2 selected stress-concentration factors have been given from a complete table in Refs. 1, 2, and 4.

10.3 COMBINED STRESSES

Under certain circumstances of loading a body is subjected to a combination of tensile, compressive, and/or shear stresses. For example, a shaft that is simultaneously bent and twisted is subjected to combined stresses, namely, longitudinal tension and compression and torsional shear. For the purposes of analysis it is convenient to reduce such systems of combined stresses to a basic system of stress coordinates known as principal stresses. These stresses act on axes that differ in general from the axes along which the applied stresses are acting and represent the maximum and minimum values of the normal stresses for the particular point considered.

Determination of Principal Stresses

The expressions for the principal stresses in terms of the stresses along the x and y axes are

$$\sigma_1 = \frac{\sigma_x + \sigma_y}{2} + \sqrt{\left(\frac{\sigma_x - \sigma_y}{2}\right)^2 + \tau_{xy}^2} \quad (10.3)$$

$$\sigma_2 = \frac{\sigma_x + \sigma_y}{2} - \sqrt{\left(\frac{\sigma_x - \sigma_y}{2}\right)^2 + \tau_{xy}^2} \quad (10.4)$$

$$\tau_1 = \pm \sqrt{\left(\frac{\sigma_x - \sigma_y}{2}\right)^2 + \tau_{xy}^2} \quad (10.5)$$

where σ_1 , σ_2 , and τ_1 are the principal stress components and σ_x , σ_y , and τ_{xy} are the calculated stress components, all of which are determined at any particular point (Fig. 10.11).

Graphical Method of Principal Stress Determination—Mohr's Circle

Let the axes x and y be chosen to represent the directions of the applied normal and shearing stresses, respectively (Fig. 10.12). Lay off to suitable scale distances $OA = \sigma_x$, $OB = \sigma_y$, and $BC = AD = \tau_{xy}$. With point E as a center construct the circle DFC . Then OF and OG are the principal stresses σ_1 and σ_2 , respectively, and EC is the maximum shear stress τ_1 . The inverse also holds—that is, given the principal stresses, σ_x and σ_y , can be determined on any plane passing through the point.

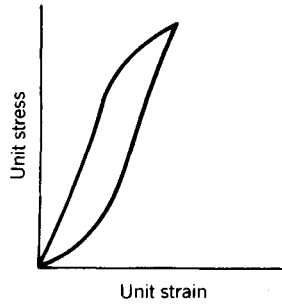

Fig. 10.10 Hysteresis loop for loading and unloading.

Stress–Strain Relations

The linear relation between components of stress and strain is known as *Hooke’s law*. This relation for the two-dimensional case can be expressed as

$$e_x = \frac{1}{E} (\sigma_x - \nu\sigma_y) \tag{10.6}$$

$$e_y = \frac{1}{E} (\sigma_y - \nu\sigma_x) \tag{10.7}$$

$$\gamma_{xy} = \frac{1}{G} \tau_{xy} \tag{10.8}$$

where σ_x , σ_y , and τ_{xy} are the stress components of a particular point, ν is Poisson’s ratio, E is modulus of elasticity, G is modulus of rigidity, and e_x , e_y , and γ_{xy} are strain components.

The determination of the magnitudes and directions of the principal stresses and strains and of the maximum shearing stresses is carried out for the purpose of establishing criteria of failure within the material under the anticipated loading conditions. To this end several theories have been advanced to elucidate these criteria. The more noteworthy ones are listed below. The theories are based on the assumption that the principal stresses do not change with time, an assumption that is justified since the applied loads in most cases are synchronous.

Maximum-Stress Theory (Rankine’s Theory)

This theory is based on the assumption that failure will occur when the maximum value of the greatest principal stress reaches the value of the maximum stress σ_{max} at failure in the case of simple axial loading. Failure is then defined as

Table 10.2 Stress-Concentration Factors^a

Type	K_t Factors						
Circular hole in plate or rectangular bar	$\frac{h}{a} = 0.67$	0.77	0.91	1.07	1.29	1.56	
	$k = 4.37$	3.92	3.61	3.40	3.25	3.16	
Square shoulder with fillet for rectangular and circular cross sections in bending	$\frac{h}{r} / \frac{r}{d}$	0.05	0.10	0.20	0.27	0.50	1.0
	0.5	1.61	1.49	1.39	1.34	1.22	1.07
	1.0	1.91	1.70	1.48	1.38	1.22	1.08
	1.5	2.00	1.73	1.50	1.39	1.23	1.08
	2.0		1.74	1.52	1.39	1.23	1.09
	3.5		1.76	1.54	1.40	1.23	1.10

^aAdapted by permission from R. J. Roark and W. C. Young, *Formulas for Stress and Strain*, 6th ed., McGraw-Hill, New York, 1989.

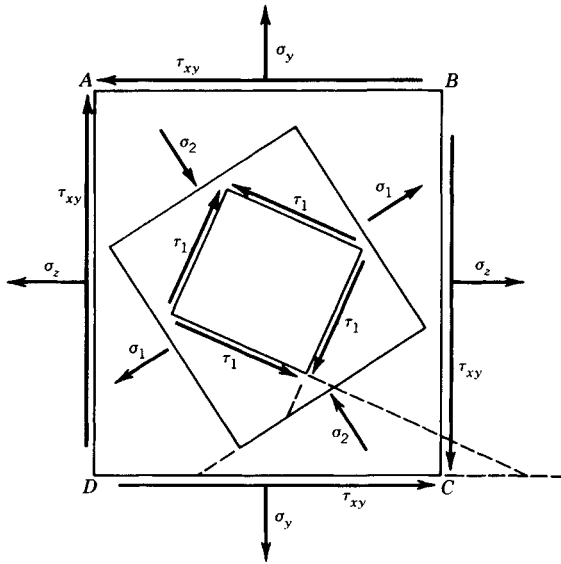

Fig. 10.11 Diagram showing relative orientation of stresses. (Reproduced by permission from J. Marin, *Mechanical Properties of Materials and Design*, McGraw-Hill, New York, 1942.)

$$\sigma_1 \text{ or } \sigma_2 = \sigma_{\max} \tag{10.9}$$

Maximum-Strain Theory (Saint Venant)

This theory is based on the assumption that failure will occur when the maximum value of the greatest principal strain reaches the value of the maximum strain e_{\max} at failure in the case of simple axial loading. Failure is then defined as

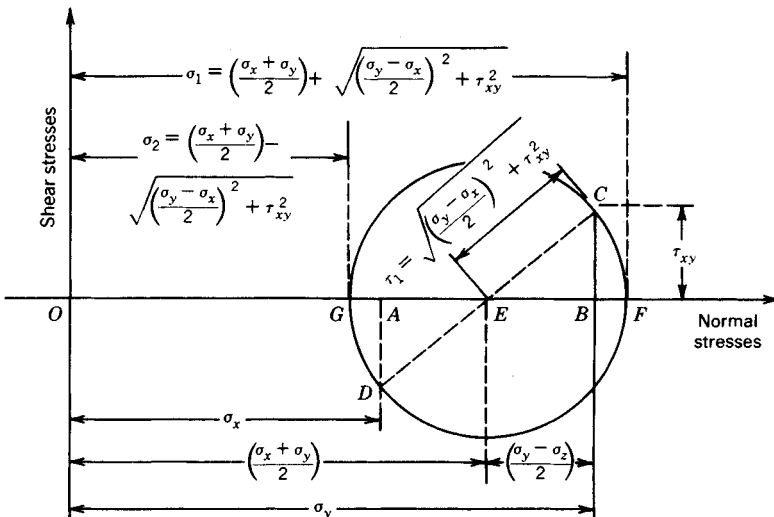

Fig. 10.12 Mohr's circle used for the determination of the principal stresses. (Reproduced by permission from J. Marin, *Mechanical Properties of Materials and Design*, McGraw-Hill, New York, 1942.)

$$e_1 \text{ or } e_2 = e_{\max} \tag{10.10}$$

If e_{\max} does not exceed the linear range of the material, Eq. (10.10) may be written as

$$\sigma_1 - \nu\sigma_2 = \sigma_{\max} \tag{10.11}$$

Maximum-Shear Theory (Guest)

This theory is based on the assumption that failure will occur when the maximum shear stress reaches the value of the maximum shear stress at failure in simple tension. Failure is then defined as

$$\tau_1 = \tau_{\max} \tag{10.12}$$

Distortion-Energy Theory (Hencky-Von Mises) (Shear Energy)

This theory is based on the assumption that failure will occur when the distortion energy corresponding to the maximum values of the stress components equals the distortion energy at failure for the maximum axial stress. Failure is then defined as

$$\sigma_1^2 - \sigma_1\sigma_2 + \sigma_2^2 = \sigma_{\max}^2 \tag{10.13}$$

Strain-Energy Theory

This theory is based on the assumption that failure will occur when the total strain energy of deformation per unit volume in the case of combined stress is equal to the strain energy per unit volume at failure in simple tension. Failure is then defined as

$$\sigma_1^2 - 2\nu\sigma_1\sigma_2 + \sigma_2^2 = \sigma_{\max}^2 \tag{10.14}$$

Comparison of Theories

Figure 10.13 compares the five foregoing theories. In general the distortion-energy theory is the most satisfactory for ductile materials and the maximum-stress theory is the most satisfactory for brittle materials. The maximum-shear theory gives conservative results for both ductile and brittle materials. The conditions for yielding, according to the various theories, are given in Table 10.3, taking $\nu = 0.300$ as for steel.

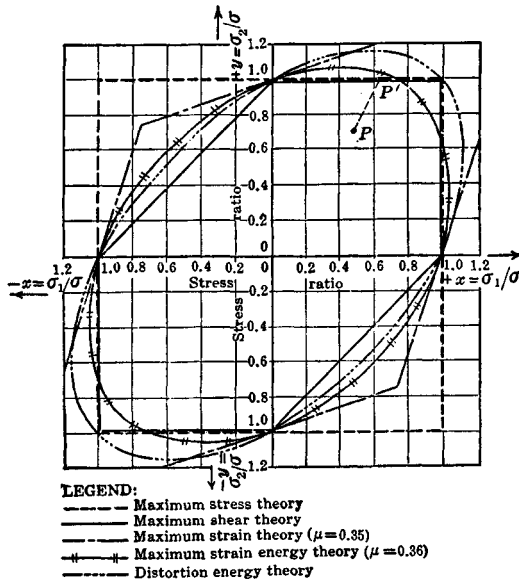

Fig. 10.13 Comparison of five theories of failure. (Reproduced by permission from J. Marin, *Mechanical Properties of Materials and Design*, McGraw-Hill, New York, 1942.)

Table 10.3 Comparison of Stress Theories

$\tau = \sigma_{yp}$	(from the maximum-stress theory)
$\tau = 0.77\sigma_{yp}$	(from the maximum-strain theory)
$\tau = 0.50\sigma_{yp}$	(from the maximum-shear theory)
$\tau = 0.62\sigma_{yp}$	(from the maximum-strain-energy theory)

Static Working Stresses

Ductile Materials. For ductile materials the criteria for working stresses are

$$\sigma_w = \frac{\sigma_{yp}}{n} \quad (\text{tension and compression}) \quad (10.15)$$

$$\tau_w = \frac{1}{2} \frac{\sigma_{yp}}{n} \quad (10.16)$$

Brittle Materials. For brittle materials the criteria for working stresses are

$$\sigma_w = \frac{\sigma_{ultimate}}{K_t \times n} \quad (\text{tension}) \quad (10.17)$$

$$\sigma_w = \frac{\sigma_{compressive}}{K_t \times n} \quad (\text{compression}) \quad (10.18)$$

where K_t is the stress-concentration factor, n is the factor of safety, σ_w and τ_w are working stresses, and σ_{yp} is stress at the yield point.

Working-Stress Equations for the Various Theories.

Stress Theory

$$\sigma_w = \frac{\sigma_x + \sigma_y}{2} \pm \sqrt{\left(\frac{\sigma_x - \sigma_y}{2}\right)^2 + \tau_{xy}^2} \quad (10.19)$$

Shear Theory

$$\sigma_w = 2 \sqrt{\left(\frac{\sigma_x - \sigma_y}{2}\right)^2 + \tau_{xy}^2} \quad (10.20)$$

Strain Theory

$$\sigma_w = (1 - \nu) \left(\frac{\sigma_x + \sigma_y}{2}\right) + (1 + \nu) \sqrt{\left(\frac{\sigma_x - \sigma_y}{2}\right)^2 + \tau_{xy}^2} \quad (10.21)$$

Distortion-Energy Theory

$$\sigma_w = \sqrt{\sigma_x^2 - \sigma_x\sigma_y + \sigma_y^2 + 3\tau_{xy}^2} \quad (10.22)$$

Strain-Energy Theory

$$\sigma_w = \sqrt{\sigma_x^2 - 2\nu\sigma_x\sigma_y + \sigma_y^2 + 2(1 + \nu)\tau_{xy}^2} \quad (10.23)$$

where σ_x , σ_y , τ_{xy} are the stress components of a particular point, ν is Poisson's ratio, and σ_w is working stress.

10.4 CREEP**Introduction**

Materials subjected to a constant stress at elevated temperatures deform continuously with time, and the behavior under these conditions is different from the behavior at normal temperatures. This continuous deformation with time is called creep. In some applications the permissible creep defor-

mations are critical, in others of no significance. But the existence of creep necessitates information on the creep deformations that may occur during the expected life of the machine. Plastic, zinc, tin, and fiber-reinforced plastics creep at room temperature. Aluminum and magnesium alloys start to creep at around 300°F. Steels above 650°F must be checked for creep.

Mechanism of Creep Failure

There are generally four distinct phases distinguishable during the course of creep failure. The elapsed time per stage depends on the material, temperature, and stress condition. They are: (1) Initial phase—where the total deformation is partially elastic and partially plastic. (2) Second phase—where the creep rate decreases with time, indicating the effect of strain hardening. (3) Third phase—where the effect of strain hardening is counteracted by the annealing influence of the high temperature which produces a constant or minimum creep rate. (4) Final phase—where the creep rate increases until fracture occurs owing to the decrease in cross-sectional area of the specimen.

Creep Equations

In conducting a conventional creep test, curves of strain as a function of time are obtained for groups of specimens; each specimen in one group is subjected to a different constant stress, while all of the specimens in the group are tested at one temperature.

In this manner families of curves like those shown in Fig. 10.14 are obtained. Several methods have been proposed for the interpretation of such data. (See Refs. 1 and 3.) Two frequently used expressions of the creep properties of a material can be derived from the data in the following form:

$$C = B\sigma^m \quad (10.24)$$

$$\epsilon = \epsilon_0 + Ct$$

where C = creep rate, B , m = experimental constants, σ = stress, ϵ = creep strain at any time t , ϵ_0 = zero-time strain intercept, and t = time. See Fig. 10.15.

Stress Relaxation

Various types of bolted joints and shrink or press fit assemblies and springs are applications of creep taking place with diminishing stress. This deformation tends to loosen the joint and produce a stress reduction or stress relaxation. The performance of a material to be used under diminishing creep-stress condition is determined by a tensile stress-relaxation test.

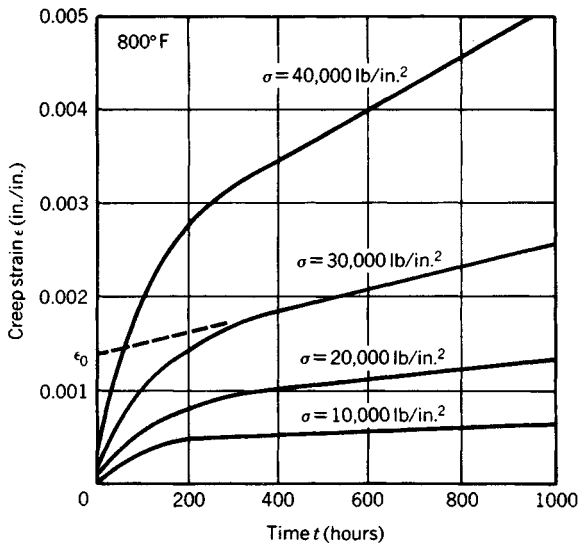

Fig. 10.14 Curves of creep strain for various stress levels.

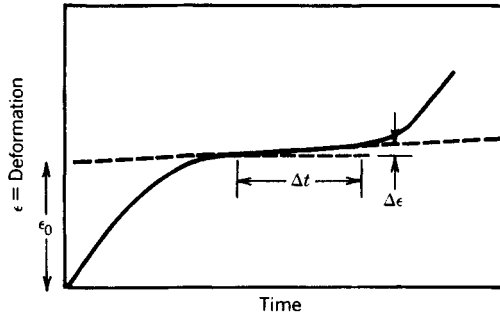

Fig. 10.15 Method of determining creep rate.

10.5 FATIGUE

Definitions

STRESS CYCLE. A stress cycle is the smallest section of the stress-time function that is repeated identically and periodically, as shown in Fig. 10.16.

MAXIMUM STRESS. σ_{\max} is the largest algebraic value of the stress in the stress cycle, being positive for a tensile stress and negative for a compressive stress.

MINIMUM STRESS. σ_{\min} is the smallest algebraic value of the stress in the stress cycle, being positive for a tensile stress and negative for a compressive stress.

RANGE OF STRESS. σ_r is the algebraic difference between the maximum and minimum stress in one cycle:

$$\sigma_r = \sigma_{\max} - \sigma_{\min} \quad (10.25)$$

For most cases of fatigue testing the stress varies about zero stress, but other types of variation may be experienced.

ALTERNATING-STRESS AMPLITUDE (VARIABLE STRESS COMPONENT), σ_a is one-half the range of stress, $\sigma_a = \sigma_r/2$.

MEAN STRESS (STEADY STRESS COMPONENT), σ_m is the algebraic mean of the maximum and minimum stress in one cycle:

$$\sigma_m = \frac{\sigma_{\max} + \sigma_{\min}}{2} \quad (10.26)$$

STRESS RATIO. R is the algebraic ratio of the minimum stress and the maximum stress in one cycle.

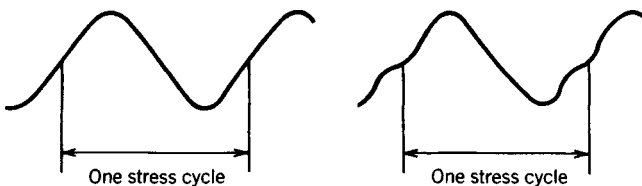

Fig. 10.16 Definition of one stress cycle.

10.5.1 Modes of Failure

The three most common modes of failure are*

$$\text{Soderberg's Law} \quad \frac{\sigma_m}{\sigma_y} + \frac{\sigma_a}{\sigma_e} = \frac{1}{N} \quad (10.27)$$

$$\text{Goodman's Law} \quad \frac{\sigma_m}{\sigma_u} + \frac{\sigma_a}{\sigma_e} = \frac{1}{N} \quad (10.28)$$

$$\text{Gerber's Law} \quad \left(\frac{\sigma_m}{\sigma_u}\right)^2 + \frac{\sigma_a}{\sigma_e} = \frac{1}{N} \quad (10.29)$$

From distortion energy for plane stress

$$\sigma_m = \sqrt{\sigma_{sm}^2 - \sigma_{sm}\sigma_{ym} + \sigma_{ym}^2 + 3\tau_{sym}^2} \quad (10.30)$$

$$\sigma_a = \sqrt{\sigma_{sa}^2 - \sigma_{sa}\sigma_{ya} + \sigma_{ya}^2 + 3\tau_{sya}^2} \quad (10.31)$$

The stress concentration factor,⁴ K , or K_f , is applied to the individual stress for both σ_a and σ_m for brittle materials and only to σ_a for ductile materials. N is a reasonable factor of safety. σ_u is the ultimate tensile strength, and σ_y is the yield strength. σ_e is developed from the endurance limit σ'_e and reduced or increased depending on conditions and manufacturing procedures and to keep σ_e less than the yield strength:

$$\sigma_e = k_a k_b \cdots k_n \sigma'_e$$

where σ'_e (Ref. 1) for various materials is:

Steel	$0.5\sigma_u$ and never greater than 100 kpsi at 10^6 cycles
Magnesium	$0.35\sigma_u$ at 10^8 cycles
Nonferrous alloys	$0.35\sigma_u$ at 10^8 cycles
Aluminum alloys	$(0.16-0.3)\sigma_u$ at 5×10^8 cycles (see Military Handbook 5D)

and where the other k factors are affected as follows:

Surface Condition. For surfaces that are from machined to ground, the k_a varies from 0.7 to 1.0.

When surface finish is known, k_a can be found¹ more accurately.

Size and Shape. If the size of the part is 0.30 in. or larger, the reduction is 0.85 or less, depending on the size.

Reliability. The endurance limit and material properties are averages and both should be corrected.

A reliability of 90% reduces values 0.897, while one of 99% reduces 0.814.

Temperature. The endurance limit at -190°C increases 1.54–2.57 for steels, 1.14 for aluminums, and 1.4 for titaniums. The endurance limit is reduced approximately 0.68 for some steels at 1382°F , 0.24 for aluminum around 662°F , and 0.4 for magnesium alloys at 572°F .

Residual Stresses. For steel, shot peening increases the endurance limit 1.04–1.22 for polished surfaces, 1.25 for machined surfaces, 1.25–1.5 for rolled surfaces, and 2–3 for forged surfaces. The shot-peening effect disappears above 500°F for steels and above 250°F for aluminum. Surface rolling affects the steel endurance limit approximately the same as shot peening, while the endurance limit is increased 1.2–1.3 in aluminum, 1.5 in magnesium, and 1.2–2.93 in cast iron.

Corrosion. A corrosive environment decreases the endurance limit of anodized aluminum and magnesium 0.76–1.00, while nitrated steel and most materials are reduced 0.6–0.8.

Surface Treatments. Nickel plating reduces the endurance limit of 1008 steel 0.01 and of 1063 steel 0.77, but, if the surface is shot peened after it is plated, the endurance limit can be increased over that of the base metal. The endurance limit of anodized aluminum is in general not affected. Flame and induction hardening as well as carburizing increases the endurance limit 1.62–1.85, while nitriding increases it 1.30–2.00.

Fretting. In surface pairs that move relative to each other, the endurance limit is reduced 0.70–0.90 for each material.

*This section is condensed from Ref. 1, Chap. 12.

Radiation. Radiation tends to increase tensile strength but to decrease ductility.

In discussions on fatigue it should be emphasized that most designs must pass vibration testing. When sizing parts so that they can be modeled on a computer, the designer needs a starting point until feedback is received from the modeling. A helpful starting point is to estimate the static load to be carried, to find the level of vibration testing in G levels, to assume that the part vibrates with a magnification of 10, and to multiply these together to get an equivalent static load. The stress level should be $\sigma_u/4$, which should be less than the yield strength. When the design is modeled, changes can be made to bring the design within the required limits.

10.6 BEAMS

10.6.1 Theory of Flexure

Types of Beams

A beam is a bar or structural member subjected to transverse loads that tend to bend it. Any structural members acts as a beam if bending is induced by external transverse forces.

A **simple beam** (Fig. 10.17a) is a horizontal member that rests on two supports at the ends of the beam. All parts between the supports have free movement in a vertical plane under the influence of vertical loads.

A **fixed beam, constrained beam, or restrained beam** (Fig. 10.17b) is rigidly fixed at both ends or rigidly fixed at one end and simply supported at the other.

A **continuous beam** (Fig. 10.17c) is a member resting on more than two supports.

A **cantilever beam** (Fig. 10.17d) is a member with one end projecting beyond the point of support, free to move in a vertical plane under the influence of vertical loads placed between the free end and the support.

Phenomena of Flexure

When a simple beam bends under its own weight, the fibers on the upper or concave side are shortened, and the stress acting on them is compression; the fibers on the under or convex side are lengthened, and the stress acting on them is tension. In addition, shear exists along each cross section, the intensity of which is greatest along the sections at the two supports and zero at the middle section.

When a cantilever beam bends under its own weight, the fibers on the upper or convex side are lengthened under tensile stresses; the fibers on the under or concave side are shortened under compressive stresses, the shear is greatest along the section at the support, and zero at the free end.

The **neutral surface** is that horizontal section between the concave and convex surfaces of a loaded beam, where there is no change in the length of the fibers and no tensile or compressive stresses acting upon them.

The **neutral axis** is the trace of the neutral surface on any cross section of a beam. (See Fig. 10.18).

The **elastic curve** of a beam is the curve formed by the intersection of the neutral surface with the side of the beam, it being assumed that the longitudinal stresses on the fibers are within the elastic limit.

Reactions at Supports

The reactions, or upward pressures at the points of support, are computed by applying the following conditions necessary for equilibrium of a system of vertical forces in the same plane: (1) The algebraic sum of all vertical forces must equal zero; that is, the sum of the reactions equals the sum of the downward loads. (2) The algebraic sum of the moments of all the vertical forces must equal zero.

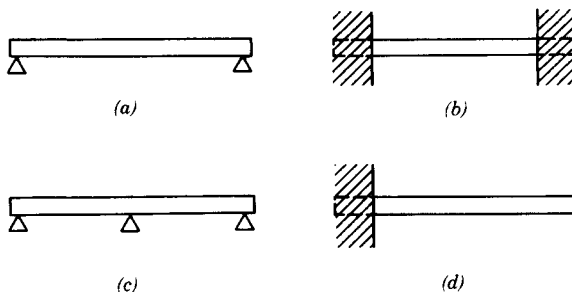

Fig. 10.17 (a) Simple, (b) constrained, (c) continuous, and (d) cantilever beams.

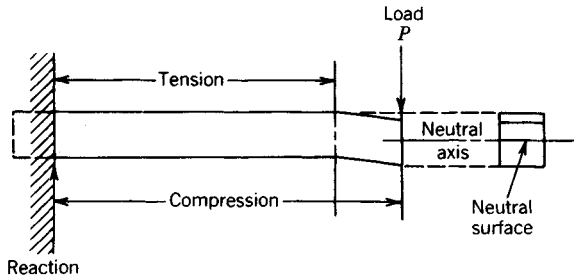

Fig. 10.18 Loads and stress conditions in a cantilever beam.

Condition (1) applies to cantilever beams and to simple beams uniformly loaded, or with equal concentrated loads placed at equal distances from the center of the beam. In the cantilever beam, the reaction is the sum of all the vertical forces acting downward, comprising the weight of the beam and the superposed loads. In the simple beam each reaction is equal to one-half the total load, consisting of the weight of the beam and the superposed loads. Condition (2) applies to a simple beam not uniformly loaded. The reactions are computed separately, by determining the moment of the several loads about each support. The sum of the moments of the load around one support is equal to the moment of the reaction of the other support around the first support.

Conditions of Equilibrium

The fundamental laws for the stresses at any cross section of a beam in equilibrium are: (1) Sum of horizontal tensile stresses = sum of horizontal compressive stresses. (2) Resisting shear = vertical shear. (3) Resisting moment = bending moment.

Vertical Shear. At any cross section of a beam the resultant of the external vertical forces acting on one side of the section is equal and opposite to the resultant of the external vertical forces acting on the other side of the section. These forces tend to cause the beam to shear vertically along the section. The value of either resultant is known as the vertical shear at the section considered. It is computed by finding the algebraic sum of the vertical forces to the left of the section; that is, it is equal to the left reaction minus the sum of the vertical downward forces acting between the left support and the section.

A **shear diagram** is a graphic representation of the vertical shear at all cross sections of the beam. Thus in the uniformly loaded simple beam (Table 10.5) the ordinates to the line represent to scale the intensity of the vertical shear at the corresponding sections of the beam. The vertical shear is greatest at the supports, where it is equal to the reactions, and it is zero at the center of the span. In the cantilever beam (Table 10.5) the vertical shear is greatest at the point of support, where it is equal to the reaction, and it is zero at the free end. Table 10.5 shows graphically the vertical shear on all sections of a simple beam carrying two concentrated loads at equal distances from the supports, the weight of the beam being neglected.

Resisting Shear. The tendency of a beam to shear vertically along any cross section, due to the vertical shear, is opposed by an internal shearing stress at that cross section known as the resisting shear; it is equal to the algebraic sum of the vertical components of all the internal stresses acting on the cross section.

If V = vertical shear, pounds; V_r = resisting shear, pounds; τ = average unit shearing stress, pounds per square inch; and A = area of the section, square inches, then at any cross section

$$V_r = V = \tau A; \quad \tau = \frac{V}{A} \quad (10.32)$$

The resisting shear is not uniformly distributed over the cross section, but the intensity varies from zero at the extreme fiber to its maximum value at the neutral axis.

At any point in any cross section the vertical unit shearing stress is

$$\tau = \frac{VA'c'}{I_t} \quad (10.33)$$

where V = total vertical shear in pounds for section considered; A' = area in square inches of cross section between a horizontal plane through the point where shear is being found and the extreme

fiber on the same side of the neutral axis; c' = distance in inches from neutral axis to center of gravity of area A' ; I = moment of inertia of the section, inches⁴; t = width of section at plane of shear, inches. Maximum value of the unit shearing stress, where A = total area, square inches, of cross section of the beam, is

$$\text{For a solid rectangular beam: } \tau = \frac{3V}{2A} \quad (10.34)$$

$$\text{For a solid circular beam: } \tau = \frac{4V}{3A} \quad (10.35)$$

Horizontal Shear. In a beam, at any cross section where there is a vertical shearing force, there must be resultant unit shearing stresses acting on the vertical faces of particles that lie at that section. On a horizontal surface of such a particle, there is a unit shearing stress equal to the unit shearing stress on a vertical surface of the particle. Equation (10.33) therefore, also gives the horizontal unit shearing stress at any point on the cross section of a beam.

Bending moment, at any cross section of a beam, is the algebraic sum of the moments of the external forces acting on either side of the section. It is positive when it causes the beam to bend convex downward, hence causing compression in upper fibers and tension in lower fibers of the beam. When the bending moment is determined from the forces that lie to the left of the section, it is positive if they act in a clockwise direction; if determined from forces on the right side, it is positive if they act in a counterclockwise direction. If the moments of upward forces are given positive signs, and the moments of downward forces are given negative signs, the bending moment will always have the correct sign, whether determined from the right or left side. The bending moment should be determined for the side for which the calculation will be simplest.

In Table 10.5 let M be the bending moment, pound-inches, at a section of a simple beam at a distance x , inches, from the left support; w = weight of beam per 1 in. of length; l = length of the beam, inches. Then the reactions are $\frac{1}{2}wl$, and $M = \frac{1}{2}wlx - \frac{1}{2}xwx$. For the sections at the supports, $x = 0$ or l and $M = 0$. For the section at the center of the span $x = \frac{1}{2}l$ and $M = \frac{1}{8}wl^2 = \frac{1}{8}Wl$, where W = total weight.

A moment diagram Table 10.5 shows the bending moment at all cross sections of a beam. Ordinates to the curve represent to scale the moments at the corresponding cross sections. The curve for a simple beam uniformly loaded is a parabola, showing $M = 0$ at the supports and $M = \frac{1}{8}wl^2 = \frac{1}{8}Wl$ at the center, M being in pound-inches.

The dangerous section is the cross section of a beam where the bending moment is greatest. In a cantilever beam it is at the point of support, regardless of the disposition of the loads. In a simple beam it is that section where the vertical shear changes from positive to negative, and it may be located graphically by constructing a shear diagram or numerically by taking the left reaction and subtracting the loads in order from the left until a point is reached where the sum of the loads subtracted equals the reaction. For a simple beam, uniformly loaded, the dangerous section is at the center of the span.

The tendency to rotate about a point in any cross section of a beam is due to the bending moment at that section. This tendency is resisted by the **resisting moment**, which is the algebraic sum of the moments of all the horizontal stresses with reference to the same point.

Formula for Flexure

Let M = bending moment; M_r = resisting moment of the horizontal fiber stresses; σ = unit stress (tensile or compressive) on any fiber, usually that one most remote from the neutral surface; c = distance of that fiber from the neutral surface. Then

$$M = M_r = \frac{\sigma I}{c} \quad (10.36)$$

$$\sigma = \frac{Mc}{I} \quad (10.37)$$

where I = moment of inertia of the cross section with respect to its neutral axis. If σ is in pounds per square inch, M must be in pound-inches, I in inches⁴ and c in inches.

Equation (10.37) is the basis of the design and investigation of beams. It is true only when the maximum horizontal fiber stress σ does not exceed the proportional limit of the material.

Moment of inertia is the sum of the products of each elementary area of the cross section multiplied by the square of the distance of that area from the assumed axis of rotation, or

$$I = \Sigma r^2 \Delta A = \int r^2 dA \quad (10.38)$$

where Σ is the sign of summation, ΔA is an elementary area of the section, and r is the distance of ΔA from the axis. The moment of inertia is greatest in those sections (such as I-beams) having much of the area concentrated at a distance from the axis. Unless otherwise stated, the neutral axis is the axis of rotation considered. I usually is expressed in inches⁴. See Table 10.4 for values of moments of inertia of various sections.

Modulus of rupture is the term applied to the value of σ as found by Eq. (10.37), when a beam is loaded to the point of rupture. Since Eq. (10.37) is true only for stresses within the proportional limit, the value σ of the rupture strength so found is incorrect. However, the equation is used, as a measure of the ultimate load-carrying capacity of a beam. The modulus of rupture does not show

Table 10.4 Elements of Sections







<p>A = area of section I = moment of inertia about axis $I-I$ c = distance from axis $I-I$ to remotest point of section</p>		<p>I/c = section modulus r = radius of gyration</p>	
	<p>RECTANGLE Axis through center</p> <p>$A = bh$ $c = h/2$ $I = bh^3/12$ $I/c = bh^2/6$ $r = h/\sqrt{12} = 0.289h$</p>		<p>RECTANGLE Axis any line through center of gravity</p> <p>$A = bh$ $c = (b \sin \alpha + h \cos \alpha)/2$ $I = bh(b^2 \sin^2 \alpha + h^2 \cos^2 \alpha)/12$ $I/c = \frac{bh(b^2 \sin^2 \alpha + h^2 \cos^2 \alpha)}{6(b \sin \alpha + h \cos \alpha)}$ $r = \frac{\sqrt{(b^2 \sin^2 \alpha + h^2 \cos^2 \alpha)/12}}$</p>
	<p>RECTANGLE Axis on base</p> <p>$A = bh$ $c = h$ $I = bh^3/3$ $I/c = bh^2/3$ $r = h/\sqrt{3} = 0.577h$</p>		<p>TRIANGLE Axis through center of gravity</p> <p>$A = bh/2$ $c = 2/3 h$ $I = bh^3/36$ $I/c = bh^2/24$ $r = h/\sqrt{18} = 0.236h$</p>
	<p>HOLLOW RECTANGLE Axis through center</p> <p>$A = bh - b_1h_1$ $c = h/2$ $I = (bh^3 - b_1h_1^3)/12$ $I/c = (bh^3 - b_1h_1^3)/6h$ $r = \sqrt{\frac{bh^3 - b_1h_1^3}{12(bh - b_1h_1)}}$</p>		<p>TRIANGLE Axis through base</p> <p>$A = bh/2$ $c = h$ $I = bh^3/12$ $I/c = bh^2/12$ $r = h/\sqrt{6} = 0.408h$</p>
	<p>RECTANGLE Axis on diagonal</p> <p>$A = bh$ $c = bh/\sqrt{b^2 + h^2}$ $I = b^3h^3/6(b^2 + h^2)$ $I/c = b^2h^2/6\sqrt{(b^2 + h^2)}$ $r = bh/\sqrt{6(b^2 + h^2)}$</p>		<p>TRIANGLE Axis through apex</p> <p>$A = bh/2$ $c = h$ $I = bh^3/4$ $I/c = bh^2/4$ $r = h/\sqrt{2} = 0.707h$</p>

Table 10.4 (Continued)

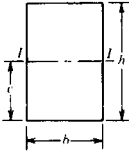
	<p>EQUILATERAL POLYGON Axis through center, parallel to one side. n = number of sides</p> $A = nR_1^2 \tan \phi$ $c = a/2 \tan \phi = R_1$ $I = \{A(12R_1^2 + a^2)\}/48$ $I/c = \{A(12R_1^2 + a^2)\}/48R_1$ $r = \sqrt{(12R_1^2 + a^2)/48}$		<p>EQUILATERAL POLYGON Axis through center, normal to side. n = number of sides</p> $A = nR_1^2 \tan \phi$ $c = a/(2 \sin \phi) = R$ $I = \{A(6R^2 - a^2)\}/24$ $I/c = \{A(6R^2 - a^2)\}/24R$ $r = \sqrt{(6R^2 - a^2)/24}$
	<p>CIRCLE Axis through center</p> $A = \pi d^2/4 = 0.7854d^2$ $c = d/2$ $I = \pi d^4/64 = 0.0491d^4$ $I/c = \pi d^3/32 = 0.0982d^3$ $r = d/4$		<p>HALF CIRCLE Axis through center of gravity</p> $A = \pi d^2/8 = 0.3927d^2$ $c = \{d(3\pi - 4)\}/6\pi = 0.2878d$ $I = \{d^4(9\pi^2 - 64)\}/1152\pi = 0.0068d^4$ $I/c = \frac{\{d^3(9\pi^2 - 64)\}}{\{192(3\pi - 4)\}} = 0.0238d^3$ $r = \{d\sqrt{(9\pi^2 - 64)}\}/12\pi = 0.1322d$
	<p>HOLLOW CIRCLE Axis through center</p> $A = \pi(d^2 - d_1^2)/4 = 0.7854(d^2 - d_1^2)$ $c = d/2$ $I = \pi(d^4 - d_1^4)/64 = 0.0491(d^4 - d_1^4)$ $I/c = \pi(d^4 - d_1^4)/32d = 0.0982(d^4 - d_1^4)/d$ $r = \sqrt{(d^2 + d_1^2)}/4$		<p>ELLIPSE Axis through center</p> $A = \pi ab/4 = 0.7854ab$ $c = a/2$ $I = \pi a^3b/64 = 0.0491a^3b$ $I/c = \pi a^2b/32 = 0.0982a^2b$ $r = a/4$
	<p>CROSSED RECTANGLES Axis through center</p> $A = th + t_1(b - t)$ $c = h/2$ $I = \{th^3 + t_1^3(b - t)\}/12$ $I/c = \{th^3 + t_1^3(b - t)\}/6h$ $r = \sqrt{\frac{th^3 + t_1^3(b - t)}{12\{th + t_1(b - t)\}}}$		<p>TRAPEZOID Axis through center of gravity</p> $A = \{(b + b_1)h\}/2$ $c = \frac{\{(b_1 + 2b)h\}}{\{3(b + b_1)\}}$ $I = \frac{h^3(b^2 + 4bb_1 + b_1^2)}{36(b + b_1)}$ $I/c = \frac{h^2(b^2 + 4bb_1 + b_1^2)}{12(b_1 + 2b)}$ $r = \frac{h}{6(b + b_1)} \sqrt{2(b^2 + 4bb_1 + b_1^2)}$

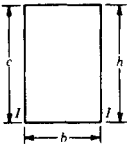
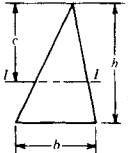
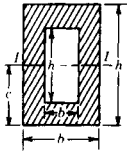
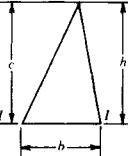
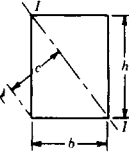
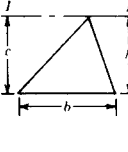
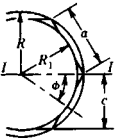
the actual stress in the extreme fiber of a beam; it is useful only as a basis of comparison. If the strength of a beam in tension differs from its strength in compression, the modulus of rupture is intermediate between the two.

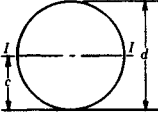
Section modulus, the factor I/c in flexure [Eq. (10.36)], is expressed in inches³. It is the measure of a capacity of a section to resist a bending moment. For values of I/c for simple shapes, see Table 10.4. See Refs. 6 and 17 for properties of standard steel and aluminum structural shapes.

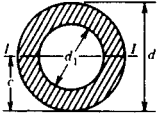
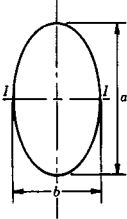
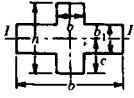
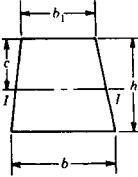
Elastic Deflection of Beams

When a beam bends under load, all points of the elastic curve except those over the supports are deflected from their original positions. The radius of curvature ρ of the elastic curve at any section is expressed as

$$\rho = \frac{EI}{M} \quad (10.39)$$

where E = modulus of elasticity of the material, pounds per square inch; I = moment of inertia, inches⁴, of the cross section with reference to its neutral axis; M = bending moment, pound-inches, at the section considered. Where there is no bending moment, ρ is infinity and the curve is a straight line; where M is greatest, ρ is smallest and the curvature, therefore, is greatest.

If the elastic curve is referred to a system of coordinate axes in which x represents horizontal distances, y vertical distances, and l distances along the curve, the value of ρ is found, by the aid of the calculus, to be $d^3l/dx \cdot d^2y$. Differential equation (10.40) of the elastic curve which applies to all beams when the elastic limit of the material is not exceeded is obtained by substituting this value in the expression $\rho = EI/M$ and assuming that dx and dl are practically equal:

$$EI \frac{d^2y}{dx^2} = M \quad (10.40)$$

Equation (10.40) is used to determine the deflection of any point of the elastic curve, by regarding the point of support as the origin of the coordinate axis, taking y as the vertical deflection at any point on the curve and x as the horizontal distance from the support to the point considered. The values of E , I , and M are substituted and the expression is integrated twice, giving proper values to the constants of integration, and the deflection y is determined for any point. See Table 10.5.

For example, a cantilever beam in Table 10.5 has a length = l , inches, and carries a load, P , pounds, at the free end. It is required to find the deflection of the elastic curve at a point distant x , inches, from the support, the weight of the beam being neglected.

The moment $M = -P(l - x)$. By substitution in Eq. (10.40), the equation for the elastic curve becomes $EI(d^2y/dx^2) = -Pl + Px$. By integrating and determining the constant of integration by the condition that $dy/dx = 0$ when $x = 0$, $EI(dy/dx) = -Plx + \frac{1}{2}Px^2$ results. By integrating a second time and determining the constant by the condition that $x = 0$ when $y = 0$, $EIy = -\frac{1}{2}Plx^2 + \frac{1}{6}Px^3$, which is the equation of the elastic curve, results. When $x = l$, the value of y , or the deflection in inches at the free end, is found to be $-Pl^3/3EI$.

Deflection due to Shear

The deflection of a beam as computed by the ordinary formulas is that due to flexural stresses only. The deflection in honeycomb, plastic and short beams due to vertical shear can be considerable, and should always be checked. Because of the nonuniform distribution of the shear over the cross section of the beam, computing the deflection due to shear by exact methods is difficult. It may be approximated by $y_s = M/AE_s$, where y_s = deflection, inches, due to shear; M = bending moment, pound-inches, at the section where the deflection is calculated; E_s = modulus of elasticity in shear, pounds per square inch; A = area of cross section of beam, square inches.⁷ For a rectangular section, the ratio of deflection due to shear to the deflection due to bending, will be less than 5% if the depth of the beam is less than one-eighth of the length.

10.6.2 Design of Beams

Design Procedure

In designing a beam the procedure is: (1) Compute reactions. (2) Determine position of the dangerous section and the bending moment at that section. (3) Divide the maximum bending moment (expressed in pound-inches) by the allowable unit stress (expressed in pounds per square inch) to obtain the minimum value of the section modulus. (4) Select a beam section with a section modulus equal to or slightly greater than the section modulus required.

Table 10.5 Bending Moment, Vertical Shear, and Deflection of Beams of Uniform Cross Section under Various Conditions of Loading

P = concentrated loads, lb
 R_1, R_2 = reactions, lb
 w = uniform load per unit of length, lb per in.
 W = total uniform load on beam, lb
 l = length of beam, in
 x = distance from support to any section, in
 E = modulus of elasticity, psi

I = moment of inertia, in.⁴
 V_x = vertical shear at any section, lb
 V = maximum vertical shear, lb
 M_x = bending moment at any section, lb-in.
 M = maximum bending moment, lb-in.
 y = maximum deflection, in.

SIMPLE BEAM—UNIFORM LOAD

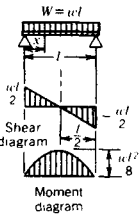

$R_1 = R_2 = \frac{wl}{2}$

$V_x = \frac{wl}{2} - wx$

$V = \pm \frac{wl}{2}$ (when $\begin{cases} x = 0 \\ x = l \end{cases}$)

$M_x = \frac{wlx}{2} - \frac{wx^2}{2}$

$M = \frac{wl^2}{8}$ (when $x = \frac{l}{2}$)

$y = \frac{5Wl^3}{384EI}$ (at center of span)

SIMPLE BEAM—CONCENTRATED LOAD AT ANY POINT

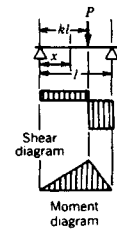

$R_1 = P(1 - k)$
 $R_2 = Pk$
 $V_x = R_1$ (when $x < kl$)
 $= R_2$ (when $x > kl$)
 $V = P(1 - k)$ (when $k < 0.5$)
 $= -Pk$ (when $k > 0.5$)
 $M_x = Pz(1 - k)$ (when $x < kl$)
 $= Pk(l - x)$ (when $x > kl$)
 $M = Pkl(1 - k)$ (at point of load)

$y = \frac{Pl^3}{3EI} (1 - k) \times (2/3k - 1/3k^2)^{3/2}$
 (at $x = l\sqrt{2/3k - 1/3k^2}$)

SIMPLE BEAM—CONCENTRATED LOAD AT CENTER

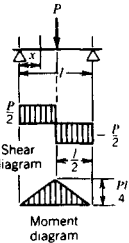

$R_1 = R_2 = \frac{P}{2}$

$V_x = V = \pm \frac{P}{2}$

$M_x = \frac{Px}{2}$

$M = \frac{Pl}{4}$ (when $x = \frac{l}{2}$)

$y = \frac{Pl^3}{48EI}$ (at center of span)

SIMPLE BEAM—TWO EQUAL CONCENTRATED LOADS AT EQUAL DISTANCES FROM SUPPORTS

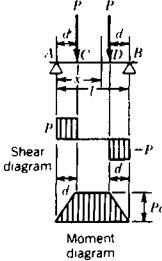

$R_1 = R_2 = P$

$V_x = P$ for AC
 $= 0$ for CD
 $= -P$ for DB

$V = \pm P$

$M_x = Px$ for AC
 $= Pd$ for CD
 $= P(l - x)$ for DB

$M = Pd$

$y = \frac{Pd}{24EI} (3l^2 - 4d^2)$
 (at center of span)

SIMPLE BEAM—LOAD INCREASING UNIFORMLY FROM SUPPORTS TO CENTER OF SPAN

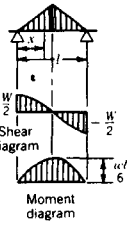

$R_1 = R_2 = \frac{W}{2}$

$V_x = W \left(\frac{l}{2} - \frac{2x^2}{l^2} \right)$
 (when $x < \frac{l}{2}$)

$V = \pm \frac{W}{2}$ (at supports)

$M_x = Wx \left(\frac{l}{2} - \frac{2x^2}{3l^2} \right)$

$M = \frac{Wl}{6}$ (at center of span)

$y = \frac{Wl^3}{60EI}$ (at center of span)

CANTILEVER BEAM—LOAD CONCENTRATED AT FREE END

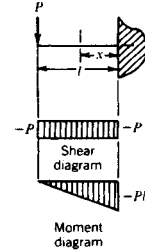

$R = P$

$V_x = V = -P$

$M_x = -P(l - x)$

$M = -Pl$ (when $x = 0$)

$y = \frac{Pl^3}{3EI}$

Table 10.5 (Continued)

<p>SIMPLE BEAM—LOAD INCREASING UNIFORMLY FROM CENTER TO SUPPORTS</p>  <p> $R_1 = R_2 = \frac{W}{2}$ $V_x = -W \left(\frac{2x}{l} - \frac{2x^2}{l^2} - \frac{1}{2} \right)$ (when $x < \frac{l}{2}$) $V = \pm \frac{W}{2}$ $M_x = Wx \left(\frac{1}{2} - \frac{x}{l} + \frac{2x^2}{3l^2} \right)$ (when $x < \frac{l}{2}$) $M = \frac{Wl}{12}$ (at center of span) $y = \frac{3}{320} \frac{Wl^3}{EI}$ (at center of span) </p>	<p>CANTILEVER BEAM—UNIFORM LOAD</p>  <p> $R = W = wl$ $V_x = -w(l - x)$ $V = -wl$ (when $x = 0$) $M_x = -w(l - x) \left(\frac{l - x}{2} \right)$ $M = -\frac{wl^2}{2}$ (when $x = 0$) $y = \frac{Wl^3}{8EI}$ </p>
<p>SIMPLE BEAM—LOAD INCREASING UNIFORMLY FROM ONE SUPPORT TO THE OTHER</p>  <p> $R_1 = \frac{W}{3}; R_2 = \frac{2}{3}W$ $V_x = W \left(\frac{1}{3} - \frac{x^2}{l^2} \right)$ $V = -\frac{2}{3}W$ (when $x = l$) $M_x = \frac{Wx}{3} \left(1 - \frac{x^2}{l^2} \right)$ $M = \frac{2}{9\sqrt{3}} Wl$ (when $x = \frac{l}{\sqrt{3}}$) $y = \frac{0.01304}{EI} Wl^3$ </p>	<p>CANTILEVER BEAM—LOAD INCREASING UNIFORMLY FROM FREE END TO SUPPORT</p>  <p> $R = W$ $V_x = -W \frac{(l - x)^2}{l^2}$ $V = -W$ (when $x = 0$) $M_x = -\frac{W}{3} \frac{(l - x)^3}{l^2}$ $M = -\frac{Wl}{3}$ (when $x = 0$) $y = \frac{Wl^3}{15EI}$ </p>
<p>FIXED BEAM—CONCENTRATED LOAD AT CENTER OF SPAN</p>  <p> $R_1 = R_2 = \frac{P}{2}$ $V_x = V = \pm \frac{P}{2}$ $M_x = P \left(\frac{x}{2} - \frac{l}{8} \right)$ $M_x = -\frac{Pl}{8}$ (when $\begin{cases} x = 0 \\ x = l \end{cases}$) $M = +\frac{Pl}{8}$ (at center of span) $y = \frac{WP^3}{192EI}$ </p>	<p>FIXED BEAM—UNIFORM LOAD</p>  <p> $R_1 = R_2 = \frac{wl}{2} = \frac{W}{2}$ $V_x = \frac{wl}{2} - wx$ $V = \pm \frac{wl}{2}$ (at ends) $M_x = -\frac{wl^2}{2} \left(\frac{1}{6} - \frac{x}{l} + \frac{x^2}{l^2} \right)$ $M = -\frac{1}{12} wl^2$ (when $\begin{cases} x = 0 \\ x = l \end{cases}$) $M = \frac{wl^2}{24}$ (when $x = \frac{l}{2}$) $y = \frac{Wl^3}{384EI}$ </p>

Table 10.5 (Continued)

<p>SIMPLE BEAM—DISTRIBUTED LOAD OVER PART OF BEAM</p>  $R_1 = \frac{wb(2c + b)}{2l}$ $R_2 = \frac{wb(2a + b)}{2l}$ $V_x = \frac{wb(2c + b)}{2l} - w(x - a)$ $V = R_1 \text{ (when } a < c)$ $= R_2 \text{ (when } a > c)$ $M_x = \frac{wbx(2c + b)}{2l} \text{ (when } x < a)$ $= R_1x - \frac{w(x - a)^2}{2}$ <p style="text-align: center;">(when $a < x < a + b$)</p> <p style="text-align: center;">(when $l - x < c$)</p> $M = \frac{wb(2c + b)[4al + b(2c + b)]}{8l^2}$	<p>BEAM SUPPORTED AT ONE END, FIXED AT OTHER—CONCENTRATED LOAD AT ANY POINT</p>  $R_1 = \frac{Pb^2(2l + a)}{2l^3}$ $R_2 = P - R_1$ $V_x = R_1 \text{ (when } x < a)$ $= R_2 \text{ (when } x > a)$ $M_x = \frac{Pb^2x(2l + a)}{2l^3}$ <p style="text-align: center;">(when $x < a$)</p> $= R_1x - P(x - a)$ <p style="text-align: center;">(when $x > a$)</p> $M_{\text{positive}} = \frac{Pab^2(2l + a)}{2l^3}$ <p style="text-align: center;">(when $x = a$)</p> $M_{\text{negative}} = -\frac{Pab(l + a)}{2l^2}$ <p style="text-align: center;">(when $x = l$)</p>
<p>FIXED BEAM—CONCENTRATED LOAD AT ANY POINT</p> <p style="text-align: center;">$a > b$</p>  $R_1 = Pb^2(l + 2a)/l^3$ $R_2 = Pa^2(l + 2b)/l^3$ $V_x = R_1 \text{ (when } x < a)$ $= R_2 \text{ (when } x > a)$ $V = R_2$ $M_x = R_1x - \frac{Pab^2}{l^2}$ <p style="text-align: center;">(when $x < a$)</p> $= R_2(l - x) - \frac{Pa^2b}{l^2}$ <p style="text-align: center;">(when $x > a$)</p> $M_{\text{positive}} = \frac{2Pa^2b^2}{l^3}$ $M_{\text{negative}} = -\frac{Pa^2b}{l^2}$ $y = -\frac{2Pa^3b^2}{3EI(3a + b)^2}$	<p>BEAM SUPPORTED AT ONE END, FIXED AT OTHER—DISTRIBUTED LOAD</p>  $R_1 = \frac{3wl}{8}$ $R_2 = \frac{5wl}{8}$ $V_x = \frac{3wl}{8} - wx$ $V = \frac{3wl}{8} \text{ (at left support)}$ $= \frac{5wl}{8} \text{ (at right support)}$ $M_x = wx \left(\frac{3l}{8} - \frac{x}{2} \right)$ $M_{\text{positive}} = \frac{9wl^2}{128}$ $M_{\text{negative}} = -\frac{wl^2}{8}$ $y = -\frac{0.0054wl^4}{EI} \text{ (at } 0.4215l \text{ from } R_1)$

Web Shear

A beam designed in the foregoing manner is safe against rupture of the extreme fibers due to bending in a vertical plane, and usually the cross section will have sufficient area to sustain the shearing stresses with safety. For short beams carrying heavy loads, however, the vertical shear at the supports is large, and it may be necessary to increase the area of the section to keep the unit shearing stress within the limit allowed. For steel beams, the average unit shearing stress is computed by $\tau = V/A$, where V = total vertical shear, pounds; A = area of web, square inches.

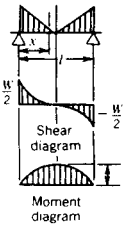
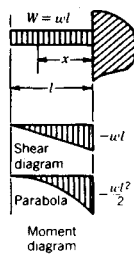
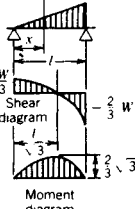
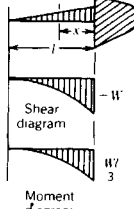
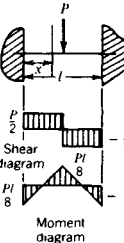
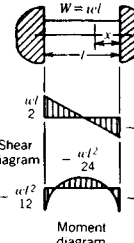
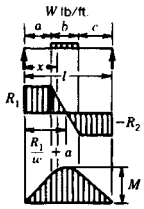
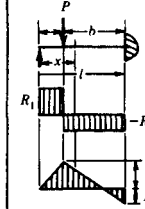
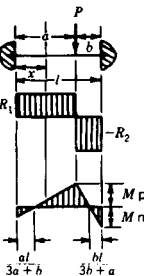
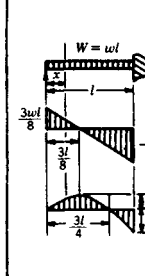
Shear Center

Closed or solid cross sections with two axes of symmetry will have a shear center at the origin. If the loads are applied here, then the bending moment can be used to calculate the deflections and bending stress, which means there are no torsional stresses. The open section or unsymmetrical section generally has a shear center that is offset on one axis of symmetry and must be calculated.^{2,8,9} The load applied at this location will develop bending stresses and deflections. If any sizable torsion is developed, then torsional stresses and rotations must be accounted for.

Miscellaneous Considerations

Other considerations which will influence the choice of section under certain conditions of loading are: (1) Maximum vertical deflection that may be permitted in beams coming in contact with plaster.

(2) Danger of failure by sidewise bending in long beams, unbraced against lateral deflection. (3) Danger of failure by the buckling of the web of steel beams of short span carrying heavy loads. (4) Danger of failure by horizontal shear, particularly in wooden beams.

Vertical Deflection

If a beam is to support or come in contact with materials like plaster, which may be broken by excessive deflection, it is usual to select such a beam that the maximum deflection will not exceed ($\frac{1}{360} \times \text{span}$). It may be shown that for a simple beam, supported at the ends, with a total uniformly distributed load W , pounds, the deflection, inches, is

$$y = \frac{30\sigma L^2}{Ed} \quad (10.41)$$

where σ = allowable unit fiber stress, pounds per square inch; L = span of beam, feet; E = modulus of elasticity, pounds per square inch; d = depth of beam, inches.

If the deflection of a steel beam is to be less than $\frac{1}{360}$ th of the span, it may be shown from Eq. (10.41) that, for a maximum allowable fiber stress of 18,000 psi, the limit of span in feet is approximately $1.8d$, where d = depth of the beam inches.

For the deflection due to the impact of a moving load falling on a beam, see Section 10.6.6.

Horizontal Shear in Timber Beams

In beams of a homogeneous material which can withstand equally well shearing stresses in any direction, vertical and horizontal shearing stresses are equally important. In timber, however, shearing strength along the grain is much less than that perpendicular to the grain. Hence, the beams may fail owing to horizontal shear. Short wooden beams should be checked for horizontal shear in order that allowable unit shearing stress along the grain shall not be exceeded. (See the example below.)

Restrained Beams

A beam is considered to be restrained if one or both ends are not free to rotate. This condition exists if a beam is built into a masonry wall at one or both ends, if it is riveted or otherwise fastened to a column, or if the ends projecting beyond the supports carry loads that tend to prevent tilting of the ends which would naturally occur as the beam deflects. The shears and moments give in Table 10.5 for fixed end conditions are seldom, if ever, attained, since the restraining elements themselves deform and reduce the magnitude of the restraint. This reduction of restraint decreases the negative moment at the support and increases the positive moment in the central portion of the span. The amount of restraint that exists is a matter which must be judged for each case in the light of the construction used, the rigidity of the connections, and the relative sizes of the connecting members.

Safe Loads on Simple Beams

Equation (10.42) gives the safe loads on simple beams. This formula is obtained by substituting in the flexure equation (10.36), the value of M for a simple beam, uniformly loaded, as given in Table 10.5. Let W = total load, pounds; σ = extreme fiber unit stress, pounds per square inch; S = section modulus, inches³; L = length of span, feet. Then

$$W = \frac{2}{3} \sigma \frac{S}{L} \quad (10.42)$$

If σ is taken as a maximum allowable unit fiber stress, this equation gives the maximum allowable load on the beam. Most building codes permit a value of $\sigma = 18,000$ psi for quiescent loads on steel. For this value of σ , Eq. (10.42) becomes

$$W = \frac{12,000 S}{L} \quad (10.43)$$

If the load is concentrated at the center of the span, the safe load is one-half the value given by Eq. (10.43). If the load is neither uniformly distributed nor concentrated at the center of the span, the maximum bending moment must be used. The foregoing equations are for beams laterally supported and are for flexure only. The other factors which influence the strength of the beam, as shearing, buckling, etc., must also be considered.

Use of Tables in Design

The following is an example in the use of tables for the design of a wooden beam.

Example 10.1

Design a southern pine girder, of common structural grade, to carry a load of 9600 lb distributed uniformly over a 16-ft span in the interior of a building, the beam being a simple beam, freely supported at each end.

Solution. From Table 10.5, the bending moment of a simple beam uniformly loaded is $M = wl^2/8$. Since $W = wl$ and $l = 12L$,

$$M = 9600 \times 16 \times \frac{1}{8} = 230,400 \text{ lb-in.}$$

If the allowable unit stress on yellow pine is 1200 psi,

$$\frac{I}{c} = \frac{230,400}{1200} = 192 \text{ in.}^3$$

From Table 10.4, the section modulus of a rectangular section is $bd^2/6$. Assume $b = 8$ in. Then $8d^2/6 = 192$, and $d = \sqrt{144} = 12.0$ in. A beam 8 by 12 in. is selected tentatively, and checked for shear.

Maximum shearing stress (horizontal and vertical) is at the neutral surface over the supports. Equation (10.34) for horizontal shear in a solid rectangular beam is $\tau = 3V/2A$; $V = 9600/2 = 4800$, and $A = 8 \times 12 = 96$, whence $\tau = (3 \times 4800)/(2 \times 96) = 75$ psi.

If the safe horizontal unit shearing stress for common-grade southern yellow pine is 88 psi, and since the actual horizontal unit shearing stress is less than 88 lb, the 8 by 12 in. beam will be satisfactory.

A **beam of uniform strength** is one in which the dimensions are such that the maximum fiber stress σ is the same throughout the length of the beam. The form of the beam is determined by finding the areas of various cross sections from the flexure formula $M = \sigma I/c$, keeping σ constant and making I/c vary with M . For a rectangular section of width b and depth d , the section modulus $I/c = \frac{1}{6}bd^2$, and, therefore, $M = \frac{1}{6}\sigma bd^2$. By making bd^2 vary with M , the dimensions of the various sections are obtained. Table 10.6 gives the dimensions b and d , at any section, the maximum unit fiber stress σ and the maximum deflection y , of some rectangular beams of uniform strength. In this table, the bending moment has been assumed to be the controlling factor. On account of the vertical shear near the ends of the beams, the area of the sections must be increased over that given by an amount necessary to keep the unit shearing stress within the allowable unit shearing stress. The discussion of beams of uniform strength, although of considerable theoretical interest, is of little practical value since the cost of fabrication will offset any economy in the use of the material. A plate girder in a bridge or a building is an approximation in practice to a steel beam of uniform strength.

10.6.3 Continuous Beams

As in simple beams, the expressions $M = \sigma I/c$ and $\tau = V/A$ govern the design and investigation of beams resting on more than two supports. In the case of continuous beams, however, the reactions cannot be obtained in the manner described for simple beams. Instead, the bending moments at the various sections must be determined, and from these values the vertical shears at the sections and the reactions at the supports may be derived.

Consider the second span of length l_2 , inches, of the continuous beam (Fig. 10.19). Vertical shear V_x at any section distant x , inches, from the left support of the span is equal to the algebraic sum of all the vertical forces on one side of the section. Thus, if $V_2 =$ vertical shear at a section to the right of, but infinitely close to, the left support, $w_2x =$ uniform load, and $\Sigma P_2 =$ sum of the concentrated loads along the distance x , applied at a distance kl_2 from the left support, k being a fraction less than unity, then

$$V_x = V_2 - w_2x - \Sigma P_2 \quad (10.44)$$

At any section, distant x from the left support, the bending moment is equal to the algebraic sum of the moments of all forces on one side of the section. If M_2 is the moment, pound-inches, at the support to the left,

$$M_x = M_2 + V_2x - \frac{w_2x^2}{2} - \Sigma P_2(x - kl_2) \quad (10.45)$$

Assume that $x = l_2$. Then M_x becomes the moment M_3 at the next support to the right, and the expression may be written

Table 10.6 Rectangular Beams of Uniform Strength*

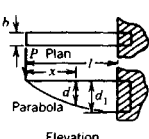
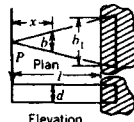
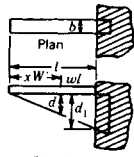
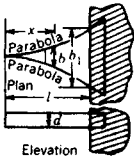
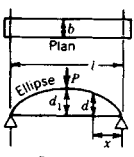
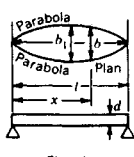
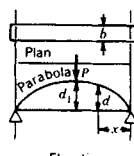
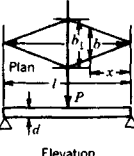
<p>I. CANTILEVER BEAM LOADED AT FREE END</p> <p>Width is constant. Depth varies.</p> $d = d_1 \sqrt{x/l}$ $\sigma = 6Pl/bd_1^2$ $y = 8Pl^3/Ed_1^3$ <p>Elevation is formed by a straight line and a parabola with its vertex at the loaded end.</p> 	<p>II. CANTILEVER BEAM LOADED AT FREE END</p> <p>Depth constant. Width varies.</p> $b = b_1x/l$ $\sigma = 6Pl/b_1d^2$ $y = 6Pl^3/Eb_1d^3$ 
<p>III. CANTILEVER BEAM UNIFORMLY LOADED</p> <p>Width is constant. Depth varies.</p> $d = (x/l)d_1$ $\sigma = 3wl^2/bd_1^2$ $y = 6wl^4/bEd_1^3$ 	<p>IV. CANTILEVER BEAM UNIFORMLY LOADED</p> <p>Depth is constant. Width varies.</p> $b = b_1x^2/l^2$ $\sigma = 3wl^2/b_1d^2$ $y = 3wl^4/b_1Ed^3$ 
<p>V. SIMPLE BEAM UNIFORMLY LOADED</p> <p>Width is constant. Depth varies.</p> $d = \sqrt{\frac{4d_1^2(lx - x^2)}{l^2}}$ $\sigma = \frac{3wl^2}{4bd_1^2}$ <p>Elevation is formed by a straight line and an ellipse.</p> 	<p>VI. SIMPLE BEAM UNIFORMLY LOADED</p> <p>Depth is constant. Width varies.</p> $b = \frac{4b_1}{l^2}(lx - x^2)$ $\sigma = \frac{3wl^2}{4b_1d^2}$ <p>Plan is two parabolas, with vertices at center of span.</p> 
<p>VII. SIMPLE BEAM LOADED AT CENTER OF SPAN</p> <p>Width is constant. Depth varies.</p> $d = d_1 \sqrt{2x/l}$ $\sigma = \frac{3Pl}{2bd_1^2}$ $y = \frac{1Pl^3}{2Ed_1^3}$ <p>Elevation is a parabola with vertices at points of support.</p> 	<p>VIII. SIMPLE BEAM LOADED AT CENTER OF SPAN</p> <p>Depth is constant. Width varies.</p> $b = 2b_1x/l$ $\sigma = \frac{3Pl}{2b_1d^2}$ $y = \frac{3Pl^3}{8Eb_1d^3}$ <p>Plan is two triangles with vertices at points of support.</p> 

* The sections of the beams near the ends must be increased over the amounts shown to resist the vertical shear expressed by the formula $\tau = 3/2 V/A$.

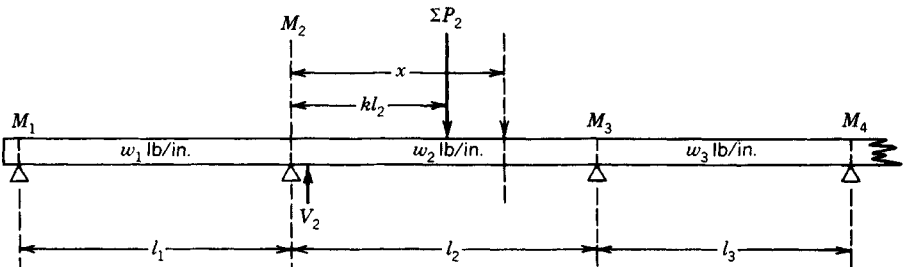

Fig. 10.19 Continuous beam.

$$V_2 l_2 = M_3 - M_2 + \frac{w_2 l_2^2}{2} + \Sigma P_2 (l_2 - k l_2) \tag{10.46}$$

From Eqs. (10.44), (10.45), and (10.46) it is evident that the bending moment M_x and the shear V_x at any section between two consecutive supports may be determined if the bending moments M_2 and M_3 at those supports are known.

To determine bending moments at the supports an expression known as the *theorem of three moments* is used. This gives the relation between the moments at any three consecutive supports of a beam. For beams with the supports on the same level, and uniformly loaded over each span, the formula is

$$M_1 l_1 + 2M_2 (l_1 + l_2) + M_3 l_2 = -\frac{1}{4} w_1 l_1^3 - \frac{1}{4} w_2 l_2^3 \tag{10.47}$$

where $M_1, M_2,$ and $M_3 =$ moments of three consecutive supports; $l_1 =$ length between first and second support; $l_2 =$ length between second and third support; $w_1 =$ uniform load per lineal unit over the first span; $w_2 =$ uniform load per lineal unit over the second span. When both spans are of equal length and when the load on each span is the same, $l_1 = l_2, w_1 = w_2,$ and Eq. (10.47) reduces to

$$M_1 + 4M_2 + M_3 = -\frac{1}{2} w l^2 \tag{10.48}$$

which applies to most cases in practice.

Equations (10.47) and (10.48) are used as follows: For any continuous beam of n spans there are $(n + 1)$ supports. Assuming the ends of the beam to be simply supported without any overhang, the moments at the end supports are zero, and there are, therefore, to be determined $(n - 1)$ moments at the other supports. This may be done by writing $(n - 1)$ equations of the form of Eqs. (10.47) and (10.48) for each support. These equations will contain $(n - 1)$ unknown moments, and their solution will give values of $M_1, M_2, M_3,$ etc., expressed as coefficients of $w l^2$. The shear V_1 at any support may be determined by substituting values of M_1 and M_2 in Eq. (10.46), and the bending moment at any point in any span may be obtained by Eq. (10.45). The shear at any point in any span may be determined from Eq. (10.44).

Figure 10.20 gives values and diagrams for the reactions, shears, and moments at all sections of continuous beams uniformly loaded up to five spans. Note that the reaction at any support is equal to the sum of the shears to the right and to the left of that support.

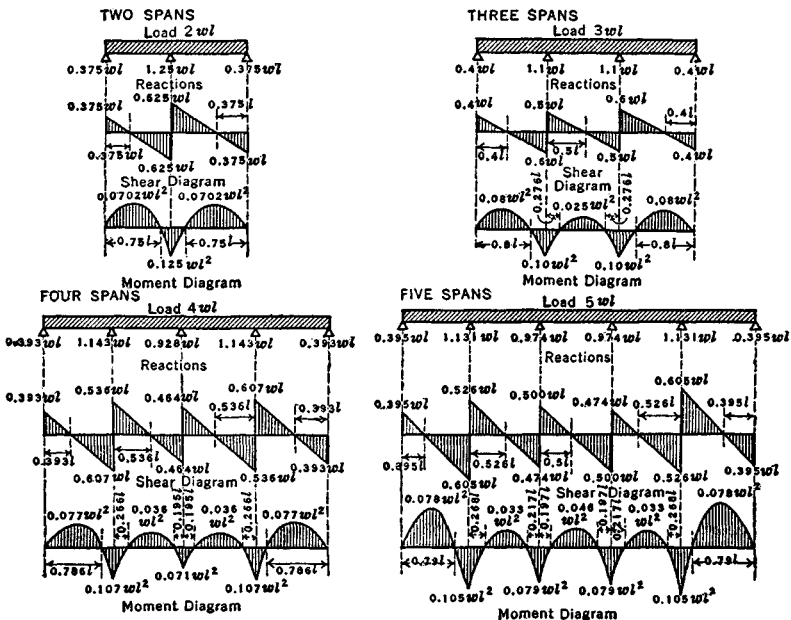

Fig. 10.20 Shear and moment diagrams of continuous beams.

10.6.4 Curved Beams

The derivation of the flexure formula, $\sigma = Mc/I$, assumes that the beam is initially straight; therefore, any deviation from this condition introduces an error in the value of the stress. If the curvature is slight, the error involved is not large, but in beams with a large amount of curvature, as hooks, chain links, and frames of punch presses, the error involved in the use of the ordinary flexure formula is considerable. The effect of the curvature is to increase the stress in the inside and to decrease it on the outside fibers of the beam and to shift the position of the neutral axis from the centroidal axis toward the concave or inner side.

The correct value for the unit fiber stress may be found by introducing a correction factor in the flexure formula, $\sigma = K(P/A \pm Mc/I)$; the factor K depends on the shape of the beam and on the ratio R/c , where R = distance, inches, from the centroidal axis of the section to the center of curvature of the central axis of the unstressed beam; and c = distance, inches, of centroidal axis from the extreme fiber on the inner or concave side. Reference 8 has an analysis of curved beams, as does Table 10.7, which gives values of K for a number of shapes and ratios of R/c . For slightly different shapes or proportions K may be found by interpolation.

Deflection of Curved and Slender Curved Beams

The deflection of curved beams,^{8,9} Fig. 10.21, in the curved portion can be found by

$$U = \int \frac{1}{2} \frac{P^2}{EA} ds + \int \frac{\phi V^2}{GA} ds + \int \frac{1}{2} \frac{M^2}{EAy_0R} ds + \int \frac{MP}{EAR} ds \quad (10.49)$$

$$\frac{\partial U}{\partial Q} = \delta_Q \quad (10.50)$$

where Q is a fictitious load of a couple where the deflection or rotation is desired or can be thought of as a 1 lb load or 1 in.-lb couple. y_0 is from Table 10.7, ϕ is a shape factor² often taken as 1, and ds is $R d\theta$. When $R/c > 4$, the last two terms condense to the integral of $(M^2/2EI) ds$. When the length of the curved portion to the depth of the beam is greater than 10, the second term of Eq. (10.49) can be dropped. When in doubt, include all terms.

When beams are not curved (Fig. 10.22), such as some clamps, the following equations (used by permission of McGraw-Hill from the 4th ed. of Ref. 2) are useful:

$$M = M_0 + HR [\sin(\theta - x) - x] - VR [\cos(\theta - x) - c] + pR^2(1 - u) \quad (10.51)$$

Vertical deflection =

$$\begin{aligned} & \frac{1}{EI} [M_0R^2(s - \theta c) + VR^3(\frac{1}{2}\theta + c^2\theta - \frac{3}{2}sc) \\ & + HR^3(\frac{1}{2} - c + sc\theta + \frac{1}{2}c^2 - s^2) + pR^4(s + sc - \frac{3}{2}\theta c - \frac{1}{2}s^3 - \frac{1}{2}c^2s)] \end{aligned} \quad (10.52)$$

Horizontal deflection =

$$\begin{aligned} & \frac{1}{EI} [M_0R^2(1 - \theta s - c) + VR^3(\frac{1}{2} - c + \theta sc + \frac{1}{2}c^2 - s^2) + \\ & HR^3(-2s + \theta s^2 + \frac{1}{2}\theta + \frac{3}{2}sc) + pR^4(1 - \frac{3}{2}\theta s + s^2 - c)] \end{aligned} \quad (10.53)$$

Rotation =

$$\frac{1}{EI} [M_0R\theta + VR^2(s - \theta c) + HR^2(1 - \theta s - c) + pR^3(\theta - s)] \quad (10.54)$$

where $u = \cos x$, $s = \sin \theta$, and $c = \cos \theta$.

10.6.5 Impact Stresses in Bars and Beams

Effect of Sudden Loads

If a sudden load P is applied to a bar, it will cause a deformation e , and the work done by the load will be Pe . Since the external work equals the internal work, Pe = $\sigma^2 A l / 2E$, and since $e = \sigma / E$, $P = \sigma A / 2$, or $\sigma = 2P / A$. The unit stress and also the unit strain are double those obtained by an equal load applied gradually. However, the bar does not maintain equilibrium at the point of maximum stress and strain. After a series of oscillations, however, in which the surplus energy is dissipated in damping, the bar finally comes to rest with the same strain and stress as that due to the equal static load.

Table 10.7 Values of Constant K for Curved Beams

Section	$\frac{R}{c}$	Values of K		$\frac{Y_0}{R}$ *	Section	$\frac{R}{c}$	Values of K		$\frac{Y_0}{R}$ *
		Inside Fiber	Outside Fiber				Inside Fiber	Outside Fiber	
	1.2	3.41	.54	.224		1.2	2.89	.57	.305
	1.4	2.40	.60	.151		1.4	2.13	.63	.204
	1.6	1.96	.65	.108		1.6	1.79	.67	.149
	1.8	1.75	.68	.084		1.8	1.63	.70	.112
	2.0	1.62	.71	.069		2.0	1.52	.73	.090
	3.0	1.33	.79	.030		3.0	1.30	.81	.041
	4.0	1.23	.84	.016		4.0	1.20	.85	.021
	6.0	1.14	.89	.0070		6.0	1.12	.90	.0093
	8.0	1.10	.91	.0039		8.0	1.09	.92	.0052
	10.0	1.08	.93	.0025		10.0	1.07	.94	.0033
	1.2	3.01	.54	.336		1.2	3.09	.56	.336
	1.4	2.18	.60	.229		1.4	2.25	.62	.229
	1.6	1.87	.65	.168		1.6	1.91	.66	.168
	1.8	1.69	.68	.128		1.8	1.73	.70	.128
	2.0	1.58	.71	.102		2.0	1.61	.73	.102
	3.0	1.33	.80	.046		3.0	1.37	.81	.046
	4.0	1.23	.84	.024		4.0	1.26	.86	.024
	6.0	1.13	.88	.011		6.0	1.17	.91	.011
	8.0	1.10	.91	.0060		8.0	1.13	.94	.0060
	10.0	1.08	.93	.0039		10.0	1.11	.95	.0039
	1.2	3.14	.52	.352		1.2	3.26	.44	.361
	1.4	2.29	.54	.243		1.4	2.39	.50	.251
	1.6	1.93	.62	.179		1.6	1.99	.54	.186
	1.8	1.74	.65	.138		1.8	1.78	.57	.144
	2.0	1.61	.68	.110		2.0	1.66	.60	.116
	3.0	1.34	.76	.050		3.0	1.37	.70	.052
	4.0	1.24	.82	.028		4.0	1.27	.75	.029
	6.0	1.15	.87	.012		6.0	1.16	.82	.013
	8.0	1.12	.91	.0060		8.0	1.12	.86	.0060
	10.0	1.11	.93	.0039		10.0	1.09	.88	.0039
	1.2	3.63	.58	.418		1.2	3.55	.67	.409
	1.4	2.54	.63	.299		1.4	2.48	.72	.292
	1.6	2.14	.67	.229		1.6	2.07	.76	.224
	1.8	1.89	.70	.183		1.8	1.83	.78	.178
	2.0	1.73	.72	.149		2.0	1.69	.80	.144
	3.0	1.41	.79	.069		3.0	1.38	.86	.067
	4.0	1.29	.83	.040		4.0	1.26	.89	.038
	6.0	1.18	.88	.018		6.0	1.15	.92	.018
	8.0	1.13	.91	.010		8.0	1.10	.94	.010
	10.0	1.10	.92	.0065		10.0	1.08	.95	.0065
	1.2	2.52	.67	.408		1.2	2.37	.73	.453
	1.4	1.90	.71	.285		1.4	1.79	.77	.319
	1.6	1.63	.75	.208		1.6	1.56	.79	.236
	1.8	1.50	.77	.160		1.8	1.44	.81	.183
	2.0	1.41	.79	.127		2.0	1.36	.83	.147
	3.0	1.23	.86	.058		3.0	1.19	.88	.067
	4.0	1.16	.89	.030		4.0	1.13	.91	.036
	6.0	1.10	.92	.013		6.0	1.08	.94	.016
	8.0	1.07	.94	.0076		8.0	1.06	.95	.0089
	10.0	1.05	.95	.0048		10.0	1.05	.96	.0057
	1.2	3.28	.58	.269		1.2	2.63	.68	.399
	1.4	2.31	.64	.182		1.4	1.97	.73	.280
	1.6	1.89	.68	.134		1.6	1.66	.76	.205
	1.8	1.70	.71	.104		1.8	1.51	.78	.159
	2.0	1.57	.73	.083		2.0	1.43	.80	.127
	3.0	1.31	.81	.038		3.0	1.23	.86	.058
	4.0	1.21	.85	.020		4.0	1.15	.89	.031
	6.0	1.13	.90	.0087		6.0	1.09	.92	.014
	8.0	1.10	.92	.0049		8.0	1.07	.94	.0076
	10.0	1.07	.93	.0031		10.0	1.06	.95	.0048

* Y_0 is distance from centroidal axis to neutral axis, where beam is subjected to pure bending.

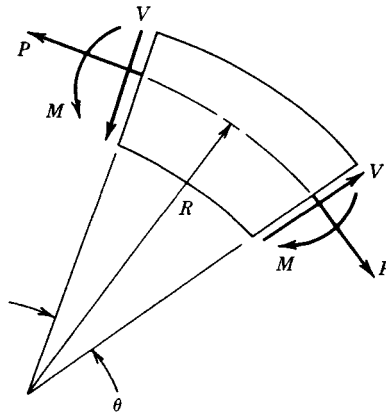

Fig. 10.21 Positive sign convention for curved beams.

Stress Due to Live Loads

In structural design two loads are considered, the dead load or weight of the structure and the live load or superimposed loads to be carried. The stresses due to the dead load and to the live load are computed separately, each being regarded as a static load. It is obvious that the stress due to the live load may be greatly increased, depending on the suddenness with which the load is applied. It has been shown above that the stress due to a suddenly applied load is double the stress caused by a static load. The term *coefficient of impact* is used extensively in structural engineering to denote the number by which the computed static stress is multiplied to obtain the value of the increased stress assumed to be caused by the suddenness of the application of the live load. If σ = static unit stress computed from the live load, and i = coefficient of impact, then the increase of unit stress due to sudden loading is $i\sigma$, and the total unit stress due to live load is $\sigma + i\sigma$. The value of i has been determined by empirical methods and varies according to different conditions.

In the building codes of most cities, specified floor loadings for buildings include the impact allowance, and no increase is needed for live loads except for special cases of vibration or other unusual conditions. For railroad bridges, the value of i depends upon the proportion of the length of the bridge which is loaded. No increase in the static stress is needed when the mass of the structure, as in monolithic concrete, is great. For machinery and for unusual conditions, such as elevator machinery and its supports, each structure should be considered by itself and the coefficient assumed accordingly. It should be noted that the meaning of the word impact used above differs somewhat from its strict theoretical meaning and as it is used in the next paragraph. The use of the terms impact and coefficient of impact in connection with live load stresses is, however, very general.

Axial Impact on Bars

A load P dropped from a height h onto the end of a vertical bar of cross-sectional area A , rigidly secured at the bottom end, produces in the bar a unit stress which increases from 0 up to σ' , with a corresponding total strain increasing from 0 up to e_1 . The work done on the bar is $P(h + e_1)$, which, provided no energy is expended in hysteresis losses or in giving velocity to the bar, is equal to the energy $\frac{1}{2}\sigma'Ae_1$ stored in the bar; that is,

$$P(h + e_1) = \frac{1}{2}\sigma'Ae_1 \tag{10.55}$$

If e = strain produced by a static load P , within the proportional limit

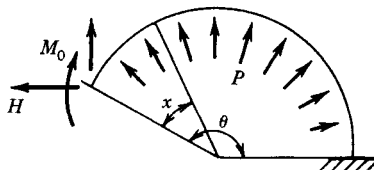

Fig. 10.22 Circular cantilever with end loading and uniform radial pressure p lb/linear in.

$$\frac{e}{e_1} = \frac{P/A}{\sigma'} \quad (10.56)$$

Combining this with Eq. (10.55) gives

$$\sigma' = \sigma + \sigma \sqrt{1 + 2 \frac{h}{e}} \quad (10.57)$$

$$e_1 = e + e \sqrt{1 + 2 \frac{h}{e}} \quad (10.58)$$

A wrought-iron bar 1 in. square and 5 ft long under a static load of 5000 lb will be shortened about 0.012 in., assuming no lateral flexure to occur; but, if a weight of 5000 lb drops on its end from a height of 0.048 in., a stress of 20,000 lb will be produced.

Equations (10.57) and (10.58) give values of stress and strain that are somewhat high because part of the energy of the applied force is not effective in producing stress, but is expended in overcoming the inertia of the bar and in producing local stresses. For light bars they give approximately correct results.

If the bar is horizontal and is struck at one end by a weight P , moving with a velocity V , the strain produced is e_1 . Then, as before, $\frac{1}{2}\sigma' A e_1 = Ph$. In this case $h = V^2/2g =$ height from which P would have to fall to acquire velocity V ($g =$ acceleration due to gravity $= 32.16 \text{ ft/sec}^2$). Combining with Eq. (10.56),

$$\sigma' = \sigma \sqrt{2 \frac{h}{e}} \quad (10.59)$$

$$e_1 = e \sqrt{2 \frac{h}{e}} \quad (10.60)$$

Impact on Beams

If a weight P falls on a horizontal beam from a height h , producing a maximum deflection y and a maximum unit stress σ' in the extreme fiber, the values of σ' and y are given by

$$\sigma' = \sigma + \sigma \sqrt{1 + 2 \frac{h}{y}} \quad (10.61)$$

$$y_1 = y + y \sqrt{1 + 2 \frac{h}{y}} \quad (10.62)$$

where $\sigma =$ extreme fiber unit stress and $y =$ deflection due to P , considered as a static load. The value of σ may be obtained from the flexure formula [Eq. (10.37)]; that of y from the proper formula for deflection under static load.

If a weight P moving horizontally with a velocity V strikes a beam (the ends of which are secured against horizontal movement), the maximum fiber unit stress and the maximum lateral deflection are given by

$$\sigma' = \sigma \sqrt{2 \frac{h}{y}} \quad (10.63)$$

$$y_1 = y \sqrt{2 \frac{h}{y}} \quad (10.64)$$

where σ and y are as before and h is height through which P would have to fall to acquire the velocity V . These formulas, like those for axial impact on bars, give results higher than those observed in tests, particularly if the weight of the beam is great. For further discussion, see Ref. 7.

Rupture from Impact

Rupture may be caused by impact provided the load has the requisite velocity. The above formulas, however, do not apply since they are valid only for stresses within the proportional limit. It has been found that the dynamic properties of a material are dependent on volume, velocity of the applied load, and material condition. If the velocity of the applied load is kept within certain limiting values,

the total energy values for static and dynamic conditions are identical. If the velocity is increased, the impact values are considerably reduced. For further information, see Ref. 10.

10.6.6 Steady and Impulsive Vibratory Stresses

For steady vibratory stresses of a weight, W , supported by a beam or rod, the deflection of the bar, or beam, will be increased by the dynamic magnification factor. The relation is given by

$$\delta_{\text{dynamic}} = \delta_{\text{static}} \times \text{dynamic magnification factor}$$

An example of the calculating procedure for the case of no damping losses is

$$\delta_{\text{dynamic}} = \delta_{\text{static}} \times \frac{1}{1 - (\omega/\omega_n)^2} \quad (10.65)$$

where ω is the frequency of oscillation of the load and ω_n is the natural frequency of oscillation of a weight on the bar.

For the same beam excited by a single sine pulse of magnitude A in./sec² and a sec duration, then for $t < a$ a good approximation is

$$\sigma_{\text{dynamic}} = \frac{\delta_{\text{static}}(A/g)}{1 - \left(\frac{\omega}{4\pi\omega_n}\right)^2} \left[\sin \omega t - \frac{1}{4\pi^2} \left(\frac{\omega}{\omega_n}\right) \sin \omega_n t \right] \quad (10.66)$$

where A/g is the number of g 's and ω is π/a .

10.7 SHAFTS, BENDING, AND TORSION

10.7.1 Definitions

TORSIONAL STRESS. A bar is under torsional stress when it is held fast at one end, and a force acts at the other end to twist the bar. In a round bar (Fig. 10.23) with a constant force acting, the straight line ab becomes the helix ad , and a radial line in the cross section, ob , moves to the position od . The angle bad remains constant while the angle bod increases with the length of the bar. Each cross section of the bar tends to shear off the one adjacent to it, and in any cross section the shearing stress at any point is normal to a radial line drawn through the point. Within the shearing proportional limit, a radial line of the cross section remains straight after the twisting force has been applied, and the unit shearing stress at any point is proportional to its distance from the axis.

TWISTING MOMENT, T , is equal to the product of the resultant, P , of the twisting forces, multiplied by its distance from the axis, p .

RESISTING MOMENT, T_r , in torsion, is equal to the sum of the moments of the unit shearing stresses acting along a cross section with respect to the axis of the bar. If dA is an elementary area of the section at a distance of z units from the axis of a circular shaft (Fig. 10.23b), and c is the distance from the axis to the outside of the cross section where the unit shearing stress is τ , then the unit shearing stress acting on dA is $(\tau z/c) dA$, its moment with respect to the axis is $(\tau z^2/c) dA$, and the sum of all the moments of the unit shearing stresses on the cross section is $\int (\tau z^2/c) dA$. In

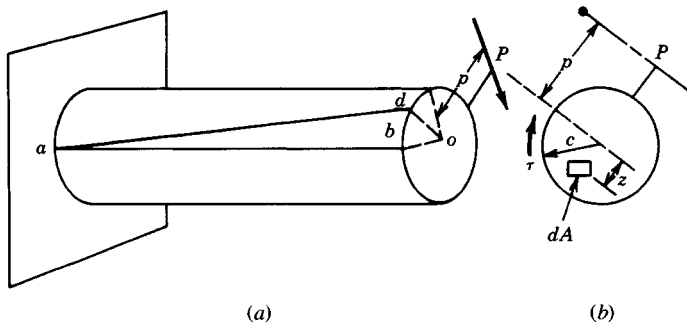

Fig. 10.23 Round bar subject to torsional stress.