

I N S T R U C T O R ' S M A N U A L

DISCRETE
MATHEMATICS



Richard Johnsonbaugh

Editor-in-Chief: Sally Yagan
Acquisitions Editor: George Lobell
Supplements Editor: Jennifer Urban
Vice President of Production & Manufacturing: David W. Riccardi
Executive Managing Editor: Kathleen Schiaparelli
Managing Editor: Nicole Jackson
Production Editor: Allyson Kloss
Manufacturing Manager: Trudy Piscioti
Asst. Manufacturing Manager: Michael Bell
Manufacturing Buyer: Ilene Kahn
Supplement Cover Designer: Elizabeth Wright



Copyright © 2005 by Pearson Education, Inc.,
Upper Saddle River, New Jersey, 07458.
Pearson Prentice Hall.

All rights reserved. No part of this book may be reproduced in any form or by any means, without permission in writing from the publisher.

Pearson Prentice Hall® is a trademark of Pearson Education, Inc.

The author and publisher of this book have used their best efforts in preparing this book. These efforts include the development, research, and testing of the theories and programs to determine their effectiveness. The author and publisher make no warranty of any kind, expressed or implied, with regard to these programs or the documentation contained in this book. The author and publisher shall not be liable in any event for incidental or consequential damages in connection with, or arising out of, the furnishing, performance, or use of these programs.

This work is protected by United States copyright laws and is provided solely for the use of instructors in teaching their courses and assessing student learning. Dissemination or sale of any part of this work (including on the World Wide Web) will destroy the integrity of the work and is not permitted. The work and materials from it should never be made available to students except by instructors using the accompanying text in their classes. All recipients of this work are expected to abide by these restrictions and to honor the intended pedagogical purposes and the needs of other instructors who rely on these materials.

Printed in the United States of America

10 9 8 7 6 5 4 3 2 1

ISBN 0-13-117687-0

Pearson Education Ltd., *London*
Pearson Education Australia Pty. Ltd., *Sydney*
Pearson Education Singapore, Pte. Ltd.
Pearson Education North Asia Ltd., *Hong Kong*
Pearson Education Canada, Inc., *Toronto*
Pearson Educación de México, S.A. de C.V.
Pearson Education—Japan, *Tokyo*
Pearson Education Malaysia, Pte. Ltd.

Table of Contents

Chapter 1	1
Chapter 2	29
Chapter 3	41
Chapter 4	49
Chapter 5	73
Chapter 6	83
Chapter 7	109
Chapter 8	129
Chapter 9	151
Chapter 10	175
Chapter 11	181
Chapter 12	193
Chapter 13	209
Appendix	215

Chapter 1

Solutions to Selected Exercises

Section 1.1

2. Not a proposition
3. Is a proposition. Negation: For every positive integer n , $19340 \neq n \cdot 17$.
5. Not a proposition
6. Is a proposition. Negation: The line "Play it again, Sam" does not occur in the movie *Casablanca*.
8. Not a proposition 10. No heads were obtained.
11. No heads or no tails were obtained.
14. True 15. True 17. False 18. False

20.

p	q	$(\neg p \vee \neg q) \vee p$
T	T	T
T	F	T
F	T	T
F	F	T

21.

p	q	$(p \vee q) \wedge \neg p$
T	T	F
T	F	F
F	T	T
F	F	F

23.

p	q	$(p \wedge q) \vee (\neg p \vee q)$
T	T	T
T	F	F
F	T	T
F	F	T

24.

p	q	r	$\neg(p \wedge q) \vee (r \wedge \neg p)$
T	T	T	F
T	T	F	F
T	F	T	T
T	F	F	T
F	T	T	T
F	T	F	T
F	F	T	T
F	F	F	T

26.

p	q	r	$\neg(p \wedge q) \vee (\neg q \vee r)$
T	T	T	T
T	T	F	F
T	F	T	T
T	F	F	T
F	T	T	T
F	T	F	T
F	F	T	T
F	F	F	T

28. $\neg(p \wedge q)$. True.29. $p \vee \neg(q \wedge r)$. True.

31. Lee takes computer science and mathematics.

32. Lee takes computer science or mathematics.

34. Lee takes computer science but not mathematics.

35. Lee takes neither computer science nor mathematics.

37. It is not Monday and either it is raining or it is hot.

38. It is not the case that (today is Monday or it is raining) and it is hot.

40. Today is Monday and either it is raining or it is hot, and it is hot or either it is raining or today is Monday.

42. $p \wedge q$ 43. $p \wedge \neg q$ 45. $p \vee q$ 46. $(p \vee q) \wedge \neg p$ 48. $p \wedge \neg r$ 49. $p \wedge q \wedge r$ 51. $\neg p \wedge \neg q \wedge r$ 52. $\neg(p \vee q \vee \neg r)$

53.

p	q	$p \text{ xor } q$
T	T	F
T	F	T
F	T	T
F	F	F

56. lung AND disease AND NOT cancer

57. minor AND league AND team AND illinois AND NOT midwest

Section 1.2

2. If Rosa has 160 quarter-hours of credits, then she may graduate.

3. If Fernando buys a computer, then he obtains \$2000.

5. If a better car is built, then Buick will build it.

6. If the chairperson gives the lecture, then the audience will go to sleep.

9. Contrapositive of Exercise 2: If Rosa does not graduate, then she does not have 160 quarter-hours of credits.

11. False 12. False 14. False 15. True 17. True

19. Unknown 20. Unknown 22. True 23. Unknown 25. Unknown

26. Unknown 29. $(p \wedge r) \rightarrow q$ 30. $\neg((r \wedge \neg q) \rightarrow r)$

33. If it is not raining, then it is hot and today is Monday.

34. If today is not Monday, then either it is raining or it is hot.

36. If today is Monday and either it is raining or it is hot, then either it is hot, it is raining, or today is Monday.

37. If today is Monday or (it is not Monday and it is not the case that (it is raining or it is hot)), then either today is Monday or it is not the case that (it is hot or it is raining).

39. Let p : $4 > 6$ and q : $9 > 12$. Given statement: $p \rightarrow q$; true. Converse: $q \rightarrow p$; if $9 > 12$, then $4 > 6$; true. Contrapositive: $\neg q \rightarrow \neg p$; if $9 \leq 12$, then $4 \leq 6$; true.

40. Let p : $|1| < 3$ and q : $-3 < 1 < 3$. Given statement: $q \rightarrow p$; true. Converse: $p \rightarrow q$; if $|1| < 3$, then $-3 < 1 < 3$; true. Contrapositive: $\neg p \rightarrow \neg q$; if $|1| \geq 3$, then either $-3 \geq 1$ or $1 \geq 3$; true.

43. $P \not\equiv Q$ 44. $P \equiv Q$ 46. $P \not\equiv Q$ 47. $P \equiv Q$ 49. $P \not\equiv Q$

50. $P \not\equiv Q$

53. (a) If p and q are both false, $(p \text{ imp2 } q) \wedge (q \text{ imp2 } p)$ is false, but $p \leftrightarrow q$ is true.

(b) Making the suggested change does not alter the last line of the *imp2* table.

54.

p	q	$\neg(p \wedge q)$	$\neg p \vee \neg q$
T	T	F	F
T	F	T	T
F	T	T	T
F	F	T	T

Section 1.3

2. The statement is a command, not a propositional function.
3. The statement is a command, not a propositional function.
5. The statement is not a propositional function since it has no variables.
6. The statement is a propositional function. The domain of discourse is the set of real numbers.
8. 1 divides 77. True. 9. 3 divides 77. False. 11. For some n , n divides 77. True.
13. Some student is taking a math course.
14. Every student is not taking a math course.
16. It is not the case that every student is taking a math course.
17. It is not the case that some student is taking a math course.
20. There is some person such that if the person is a professional athlete, then the person plays soccer. True.
21. Every soccer player is a professional athlete. False.
23. Every person is either a professional athlete or a soccer player. False.
24. Someone is either a professional athlete or a soccer player. True.
26. Someone is a professional athlete and a soccer player. True.
29. $\exists x(P(x) \wedge Q(x))$
30. $\forall x(Q(x) \rightarrow P(x))$
34. True 35. True 37. False 38. True
40. No. The suggested replacement returns false if $\neg P(d_1)$ is true, and true if $\neg P(d_1)$ is false.
42. Literal meaning: Every old thing does not covet a twenty-something. Intended meaning: Some old thing does not covet a twenty-something. Let $P(x)$ denote the statement " x is an old thing" and $Q(x)$ denote the statement " x covets a twenty-something." The intended statement is $\exists x(P(x) \wedge \neg Q(x))$.
43. Literal meaning: Every hospital did not report every month. (Domain of discourse: the 74 hospitals.) Intended meaning (most likely): Some hospital did not report every month. Let $P(x)$ denote the statement " x is a hospital" and $Q(x)$ denote the statement " x reports every month." The intended statement is $\exists x(P(x) \wedge \neg Q(x))$.
45. Literal meaning: Everyone does not have a degree. (Domain of discourse: People in Door County.) Intended meaning: Someone does not have a degree. Let $P(x)$ denote the statement " x has a degree." The intended statement is $\exists x\neg P(x)$.

40. for $i = 1$ to n
 if (*forall_dj*(i)
 return true
 return false

forall_dj(i) {
 for $j = 1$ to n
 if ($\neg P(d_i, d_j)$)
 return false
 return true
 }

41. for $i = 1$ to n
 for $j = 1$ to n
 if ($P(d_i, d_j)$)
 return true
 return false

43. Since the first two quantifiers are universal and the last quantifier is existential, Farley chooses x and y , after which, you choose z . If Farley chooses values that make $x \geq y$, say $x = y = 0$, whatever value you choose for z ,

$$(z > x) \wedge (z < y)$$

is false. Since Farley can always win the game, the quantified propositional function is false.

44. Since the first two quantifiers are universal and the last quantifier is existential, Farley chooses x and y , after which, you choose z . Whatever values Farley chooses, you can choose z to be one less than the minimum of x and y ; thus making

$$(z < x) \wedge (z < y)$$

true. Since you can always win the game, the quantified propositional function is true.

46. Since the first two quantifiers are universal and the last quantifier is existential, Farley chooses x and y , after which, you choose z . If Farley chooses values such that $x \geq y$, the proposition

$$(x < y) \rightarrow ((z > x) \wedge (z < y))$$

is true by default (i.e., it is true regardless of what value you choose for z). If Farley chooses values such that $x < y$, you can choose $z = (x + y)/2$ and again the proposition

$$(x < y) \rightarrow ((z > x) \wedge (z < y))$$

is true. Since you can always win the game, the quantified propositional function is true.

48. The proposition must be true. $P(x, y)$ is true for all x and y ; therefore, no matter which value for x we choose, the proposition $\forall y P(x, y)$ is true.

49. The proposition must be true. Since $P(x, y)$ is true for all x and y , we may choose *any* values for x and y to make $P(x, y)$ true.

51. The proposition can be false. Let $P(x, y)$ be the statement $x \geq y$ and let the domain of discourse be the set of positive integers. Then $\forall x \exists y P(x, y)$ is true, but $\exists x \forall y P(x, y)$ is false.
52. The proposition must be true. Since $\forall x \exists y P(x, y)$ is true, if we choose any value for x whatsoever, there exists a value for y for which $P(x, y)$ is true. Therefore $\exists x \exists y P(x, y)$ is true.
54. The proposition can be false. Let the domain of discourse consist of the persons James James, Terry James, and Lee James, and let $P(x, y)$ be the statement “ x ’s first name is the same as y ’s last name.” Then $\exists x \forall y P(x, y)$ is true, but $\forall x \exists y P(x, y)$ is false.
55. The proposition must be true. Since $\exists x \forall y P(x, y)$ is true, there is some value for x for which $\forall y P(x, y)$ is true. Choosing any value for y whatsoever makes $P(x, y)$ true. Therefore $\exists x \exists y P(x, y)$ is true.
57. The proposition can be false. Let $P(x, y)$ be the statement $x > y$ and let the domain of discourse be the set of positive integers. Then $\exists x \exists y P(x, y)$ is true, but $\forall x \exists y P(x, y)$ is false.
58. The proposition can be false. Let $P(x, y)$ be the statement $x > y$ and let the domain of discourse be the set of positive integers. Then $\exists x \exists y P(x, y)$ is true, but $\exists x \forall y P(x, y)$ is false.
60. Not equivalent. Let $P(x, y)$ be the statement $x > y$ and let the domain of discourse be the set of positive integers. Then $\neg(\forall x \exists y P(x, y))$ is true, but $\forall x \neg(\exists y P(x, y))$ is false.
61. Equivalent by De Morgan’s law

Section 1.5

2. For all x , for all y , $x + y = y + x$.
3. An *isosceles trapezoid* is a trapezoid with equal legs.
5. The medians of any triangle intersect at a single point.
6. If $0 < x < 1$ and $\varepsilon > 0$, there exists a positive integer n satisfying $x^n < \varepsilon$.
8. Let m and n be odd integers. Then there exist k_1 and k_2 such that $m = 2k_1 + 1$ and $n = 2k_2 + 1$.

Now

$$m + n = (2k_1 + 1) + (2k_2 + 1) = 2(k_1 + k_2 + 1).$$

Therefore, $m + n$ is even.

9. Let m and n be even integers. Then there exist k_1 and k_2 such that $m = 2k_1$ and $n = 2k_2$.

Now

$$mn = (2k_1)(2k_2) = 2(2k_1k_2).$$

Therefore, mn is even.

11. Let m be an odd integer and n be an even integer. Then there exist k_1 and k_2 such that $m = 2k_1 + 1$ and $n = 2k_2$. Now

$$mn = (2k_1 + 1)(2k_2) = 2(2k_1k_2 + k_2).$$

Therefore, mn is even.

12. From the definition of max, it follows that $d \geq d_1$ and $d \geq d_2$. From $x \geq d$ and $d \geq d_1$, we may derive $x \geq d_1$ from a previous theorem (the second theorem of Example 1.5.5). From $x \geq d$ and $d \geq d_2$, we may derive $x \geq d_2$ from the same previous theorem. Therefore, $x \geq d_1$ and $x \geq d_2$.

14.

<i>Step</i>	<i>Justification</i>
1. $xy = 0, x \neq 0, y \neq 0$	Hypothesis
2. $x \cdot 0 = 0$	Exercise 7
3. $xy = x \cdot 0$	Two things equal to the same thing are equal to each other.
4. $y = 0$	Steps 1 and 3 and the property given in the statement of Exercise 8.

15. Suppose that every box contains less than 12 balls. Then each box contains at most 11 balls and the maximum number of balls contained by the nine boxes is $9 \cdot 11 = 99$. Contradiction.

17. Suppose that there does not exist i such that $s_i \geq A$. Then, for all i , $s_i < A$. Now

$$A = \frac{s_1 + s_2 + \cdots + s_n}{n} < \frac{A + A + \cdots + A}{n} = \frac{nA}{n} = A,$$

which is a contradiction.

18. The statement is false. A counterexample is $s_i = A$ for all i .

20. First assume that $x \geq 0$ and $y \geq 0$. Then $xy \geq 0$ and $|xy| = xy = |x||y|$. Next assume that $x < 0$ and $y \geq 0$. Then $xy \leq 0$ and $|xy| = -xy = (-x)(y) = |x||y|$. Next assume that $x \geq 0$ and $y < 0$. Then $xy \leq 0$ and $|xy| = -xy = (x)(-y) = |x||y|$. Finally assume that $x < 0$ and $y < 0$. Then $xy > 0$ and $|xy| = xy = (-x)(-y) = |x||y|$.

21. First, note that from Exercise 20, for all x ,

$$|-x| = |(-1)x| = |-1||x| = |x|.$$

Example 1.5.14 states that for all x , $x \leq |x|$. Using these results, we consider two cases: $x + y \geq 0$ and $x + y < 0$. If $x + y \geq 0$, we have

$$|x + y| = x + y \leq |x| + |y|.$$

If $x + y < 0$, we have

$$|x + y| = -(x + y) = -x - y \leq |-x| + |-y| = |x| + |y|.$$

23. Suppose that $xy > 0$. Then either $x > 0$ and $y > 0$ or $x < 0$ and $y < 0$. If $x > 0$ and $y > 0$,

$$\operatorname{sgn}(xy) = 1 = 1 \cdot 1 = \operatorname{sgn}(x)\operatorname{sgn}(y).$$

If $x < 0$ and $y < 0$,

$$\operatorname{sgn}(xy) = 1 = -1 \cdot -1 = \operatorname{sgn}(x)\operatorname{sgn}(y).$$

Next, suppose that $xy = 0$. Then either $x = 0$ or $y = 0$. Thus either $\operatorname{sgn}(x) = 0$ or $\operatorname{sgn}(y) = 0$. In either case, $\operatorname{sgn}(x)\operatorname{sgn}(y) = 0$. Therefore

$$\operatorname{sgn}(xy) = 0 = \operatorname{sgn}(x)\operatorname{sgn}(y).$$

Finally, suppose that $xy < 0$. Then either $x > 0$ and $y < 0$ or $x < 0$ and $y > 0$. If $x > 0$ and $y < 0$,

$$\operatorname{sgn}(xy) = -1 = 1 \cdot -1 = \operatorname{sgn}(x)\operatorname{sgn}(y).$$

If $x < 0$ and $y > 0$,

$$\operatorname{sgn}(xy) = -1 = -1 \cdot 1 = \operatorname{sgn}(x)\operatorname{sgn}(y).$$

$$24. |xy| = \operatorname{sgn}(xy)xy = \operatorname{sgn}(x)\operatorname{sgn}(y)xy = [\operatorname{sgn}(x)x][\operatorname{sgn}(y)y] = |x||y|$$

26. Suppose that $x \geq y$. Then

$$\max\{x, y\} = x \quad \text{and} \quad |x - y| = x - y.$$

Thus

$$\max\{x, y\} = x = \frac{2x}{2} = \frac{x + y + x - y}{2} = \frac{x + y + |x - y|}{2}.$$

The other case is $x < y$. Then

$$\max\{x, y\} = y \quad \text{and} \quad |x - y| = y - x.$$

Thus

$$\max\{x, y\} = y = \frac{2y}{2} = \frac{x + y + y - x}{2} = \frac{x + y + |x - y|}{2}.$$

27. Suppose that $x \geq y$. Then

$$\min\{x, y\} = y \quad \text{and} \quad |x - y| = x - y.$$

Thus

$$\min\{x, y\} = y = \frac{2y}{2} = \frac{x + y - (x - y)}{2} = \frac{x + y - |x - y|}{2}.$$

The other case is $x < y$. Then

$$\min\{x, y\} = x \quad \text{and} \quad |x - y| = y - x.$$

Thus

$$\min\{x, y\} = x = \frac{2x}{2} = \frac{x + y - (y - x)}{2} = \frac{x + y - |x - y|}{2}.$$

29. Let i be the greatest integer for which s_i is positive. Since s_1 is positive and the set of indexes $1, 2, \dots, n$ is finite, such an i exists. Since s_n is negative, $i < n$. Now s_{i+1} is equal to either $s_i + 1$ or $s_i - 1$. If $s_{i+1} = s_i + 1$, then s_{i+1} is a positive integer (since s_i is a positive integer). This contradicts the fact that i is the *greatest* integer for which s_i is positive. Therefore, $s_{i+1} = s_i - 1$. Again, if $s_i - 1$ is a positive integer, we have a contradiction. Therefore, $s_{i+1} = s_i - 1 = 0$.

30. A counterexample is $n = 3$.

32. Invalid

$$\frac{p \rightarrow q \quad \neg r \rightarrow \neg q}{\therefore r}$$

33. Valid

$$\frac{p \leftrightarrow r \quad r}{\therefore p}$$

35. Valid

$$\frac{p \rightarrow (q \vee r) \quad \neg q \wedge \neg r}{\therefore \neg p}$$

37. If 4 megabytes of memory is better than no memory at all, then either we will buy a new computer or we will buy more memory. If we will buy a new computer, then we will not buy more memory. Therefore if 4 megabytes of memory is better than no memory at all, then we will buy a new computer. Invalid.

38. If 4 megabytes of memory is better than no memory at all, then we will buy a new computer. If we will buy a new computer, then we will buy more memory. Therefore, we will buy more memory. Invalid.

40. If 4 megabytes of memory is better than no memory at all, then we will buy a new computer. If we will buy a new computer, then we will buy more memory. 4 megabytes of memory is better than no memory at all. Therefore we will buy more memory. Valid.

42. Valid 43. Valid 45. Valid

46. Suppose that p_1, p_2, \dots, p_n are all true. Since the argument $p_1, p_2 / \therefore p$ is valid, p is true. Since p, p_3, \dots, p_n are all true and the argument

$$p, p_3, \dots, p_n / \therefore c$$

is valid, c is true. Therefore the argument

$$p_1, p_2, \dots, p_n / \therefore c$$

is valid.

48. Let

$p(x)$: x is good.

$q(x)$: x is too long.

$r(x)$: x is short enough.

The domain of discourse is the set of movies. The assertions are

$$\begin{array}{l}
 \forall x(p(x) \rightarrow \neg q(x)) \\
 \neg \forall x(\neg p(x) \rightarrow \neg r(x)) \\
 p(\text{"Love Actually"}) \\
 q(\text{"Love Actually"}).
 \end{array}$$

By universal instantiation,

$$p(\text{"Love Actually"}) \rightarrow \neg q(\text{"Love Actually"}).$$

Since $p(\text{"Love Actually"})$ is true, then $\neg q(\text{"Love Actually"})$ is also true. But this contradicts, $q(\text{"Love Actually"})$.

50. Modus ponens 51. Disjunctive syllogism 52. Universal instantiation

54. Let p denote the proposition "there is gas in the car," let q denote the proposition "I go to the store," let r denote the proposition "I get a soda," and let s denote the proposition "the car transmission is defective." Then the hypotheses are:

$$p \rightarrow q, \quad q \rightarrow r, \quad \neg r.$$

From $p \rightarrow q$ and $q \rightarrow r$, we may use the hypothetical syllogism to conclude $p \rightarrow r$. From $p \rightarrow r$ and $\neg r$, we may use modus tollens to conclude $\neg p$. From $\neg p$, we may use addition to conclude $\neg p \vee s$. Since $\neg p \vee s$ represents the proposition "there is not gas in the car or the car transmission is defective," we conclude that the conclusion does follow from the hypotheses.

55. Let p denote the proposition "Jill can sing," let q denote the proposition "Dweezle can play," let r denote the proposition "I'll buy the compact disk," and let s denote the proposition "I'll buy the compact disk player." Then the hypotheses are:

$$(p \vee q) \rightarrow r, \quad p, \quad s.$$

From p , we may use addition to conclude $p \vee q$. From $p \vee q$ and $(p \vee q) \rightarrow r$, we may use modus ponens to conclude r . From r and s , we may use conjunction to conclude $r \wedge s$. Since $r \wedge s$ represents the proposition "I'll buy the compact disk and the compact disk player," we conclude that the conclusion does follow from the hypotheses.

57. Let $P(x)$ denote the propositional function " x is a member of the Titans," let $Q(x)$ denote the propositional function " x can hit the ball a long way," and let $R(x)$ denote the propositional function " x can make a lot of money." The hypotheses are

$$P(\text{Ken}), \quad Q(\text{Ken}), \quad \forall x Q(x) \rightarrow R(x).$$

By universal instantiation, we have $Q(\text{Ken}) \rightarrow R(\text{Ken})$. From $Q(\text{Ken})$ and $Q(\text{Ken}) \rightarrow R(\text{Ken})$, we may use modus ponens to conclude $R(\text{Ken})$. From $P(\text{Ken})$ and $R(\text{Ken})$, we may use conjunction to conclude $P(\text{Ken}) \wedge R(\text{Ken})$. By existential generalization, we have $\exists x P(x) \wedge R(x)$ or, in words, someone is a member of the Titans and can make a lot of money. We conclude that the conclusion does follow from the hypotheses.

58. Let $P(x)$ denote the propositional function “ x is in the discrete mathematics class,” let $Q(x)$ denote the propositional function “ x loves proofs,” and let $R(x)$ denote the propositional function “ x has taken calculus.” The hypotheses are

$$\forall x P(x) \rightarrow Q(x), \quad \exists x P(x) \wedge \neg R(x).$$

By existential instantiation, we have $P(d) \wedge \neg R(d)$ for some d in the domain of discourse. From $P(d) \wedge \neg R(d)$, we may use simplification to conclude $P(d)$ and $\neg R(d)$. By universal instantiation, we have $P(d) \rightarrow Q(d)$. From $P(d) \rightarrow Q(d)$ and $P(d)$, we may use modus ponens to conclude $Q(d)$. From $Q(d)$ and $\neg R(d)$, we may use conjunction to conclude $Q(d) \wedge \neg R(d)$. By existential generalization, we have $\exists Q(x) \wedge \neg R(x)$ or, in words, someone who loves proofs has never taken calculus. We conclude that the conclusion does follow from the hypotheses.

60. The truth table

p	q	$p \vee q$
T	T	T
T	F	T
F	T	T
F	F	F

shows that whenever p is true, $p \vee q$ is also true. Therefore addition is a valid argument.

61. The truth table

p	q	$p \wedge q$
T	T	T
T	F	F
F	T	F
F	F	F

shows that whenever $p \wedge q$ is true, p is also true. Therefore simplification is a valid argument.

63. The truth table

p	q	r	$p \rightarrow q$	$q \rightarrow r$	$p \rightarrow r$
T	T	T	T	T	T
T	T	F	T	F	F
T	F	T	F	T	T
T	F	F	F	T	F
F	T	T	T	T	T
F	T	F	T	F	T
F	F	T	T	T	T
F	F	F	T	T	T

shows that whenever $p \rightarrow q$ and $q \rightarrow r$ are true, $p \rightarrow r$ is also true. Therefore hypothetical syllogism is a valid argument.

64. The truth table

p	q	$p \vee q$	$\neg p$
T	T	T	F
T	F	T	F
F	T	T	T
F	F	F	T

shows that whenever $p \vee q$ and $\neg p$ are true, q is also true. Therefore disjunctive syllogism is a valid argument.

66. By definition, the proposition $\exists x \in D P(x)$ is true when $P(x)$ is true for some x in the domain of discourse. Taking x equal to a $d \in D$ for which $P(d)$ is true, we find that $P(d)$ is true for some $d \in D$.

67. By definition, the proposition $\exists x \in D P(x)$ is true when $P(x)$ is true for some x in the domain of discourse. Since $P(d)$ is true for some $d \in D$, $\exists x \in D P(x)$ is true.

Section 1.6

3.
 1. $\neg p \vee r$
 2. $\neg r \vee q$
 3. p
 4. $\neg p \vee q$ from 1,2
 5. q from 3,4

4.
 1. $\neg p \vee t$
 2. $\neg q \vee s$
 3. $\neg r \vee s$
 4. $\neg r \vee t$
 5. $p \vee q \vee r \vee u$
 6. $t \vee q \vee r \vee u$ from 1,5
 7. $s \vee t \vee r \vee u$ from 2,6
 8. $s \vee t \vee u$ from 3,7

6. $(p \leftrightarrow r) \equiv (p \rightarrow r)(r \rightarrow p) \equiv (\neg p \vee r)(\neg r \vee p)$
 1. $\neg p \vee r$
 2. $\neg r \vee p$
 3. r
 4. p from 2,3

8.
 1. $a \vee \neg b$
 2. $a \vee c$
 3. $\neg a$
 4. $\neg d$
 5. b negated conclusion
 6. $\neg b$ from 1,3

Now 5 and 6 combine to give a contradiction.

Section 1.7

In some of these solutions, the Basis Steps are omitted.

$$\begin{aligned} 2. \quad & 1 \cdot 2 + 2 \cdot 3 + \cdots + n(n+1) + (n+1)(n+2) \\ &= \frac{n(n+1)(n+2)}{3} + (n+1)(n+2) = \frac{(n+1)(n+2)(n+3)}{3} \end{aligned}$$

$$\begin{aligned} 3. \quad & 1(1!) + 2(2!) + \cdots + n(n!) + (n+1)(n+1)! \\ &= (n+1)! - 1 + (n+1)(n+1)! = (n+2)! - 1 \end{aligned}$$

$$\begin{aligned} 5. \quad & 1^2 - 2^2 + \cdots + (-1)^{n+1}n^2 + (-1)^{n+2}(n+1)^2 \\ &= \frac{(-1)^{n+1}n(n+1)}{2} + (-1)^{n+2}(n+1)^2 = \frac{(-1)^{n+2}(n+1)(n+2)}{2} \end{aligned}$$

$$\begin{aligned} 6. \quad & 1^3 + 2^3 + \cdots + n^3 + (n+1)^3 \\ &= \left[\frac{n(n+1)}{2} \right]^2 + (n+1)^3 = \left[\frac{(n+1)(n+2)}{2} \right]^2 \end{aligned}$$

$$\begin{aligned} 8. \quad & \frac{1}{2 \cdot 4} + \frac{1 \cdot 3}{2 \cdot 4 \cdot 6} + \cdots + \frac{1 \cdot 3 \cdots (2n-1)}{2 \cdot 4 \cdots (2n+2)} + \frac{1 \cdot 3 \cdots (2n-1)(2n+1)}{2 \cdot 4 \cdots (2n+2)(2n+4)} \\ &= \frac{1}{2} - \frac{1 \cdot 3 \cdots (2n+1)}{2 \cdot 4 \cdots (2n+2)} + \frac{1 \cdot 3 \cdots (2n-1)(2n+1)}{2 \cdot 4 \cdots (2n+2)(2n+4)} \\ &= \frac{1}{2} - \frac{1 \cdot 3 \cdots (2n+3)}{2 \cdot 4 \cdots (2n+4)} \end{aligned}$$

$$\begin{aligned} 9. \quad & \frac{1}{2^2-1} + \frac{1}{3^2-1} + \cdots + \frac{1}{(n+1)^2-1} + \frac{1}{(n+2)^2-1} \\ &= \frac{3}{4} - \frac{1}{2(n+1)} - \frac{1}{2(n+2)} + \frac{1}{(n+2)^2-1} \\ &= \frac{3}{4} - \frac{1}{2(n+2)} - \frac{1}{2(n+3)} \end{aligned}$$

11. The solution is similar to that for Exercise 10, which is given in the book.

13. First note that

$$\frac{1 \cdot 3 \cdots (2n-1)(2n+1)}{2 \cdot 4 \cdots (2n)(2n+2)} \leq \frac{1}{\sqrt{n+1}} \frac{2n+1}{2n+2}.$$

The proof will be complete if we can show that

$$\frac{2n+1}{(2n+2)\sqrt{n+1}} \leq \frac{1}{\sqrt{n+2}}.$$

This last inequality is successively equivalent to

$$\left(\frac{n+2}{n+1} \right)^{1/2} \leq \frac{2n+2}{2n+1}$$

$$\begin{aligned}\frac{n+2}{n+1} &\leq \frac{4(n+1)^2}{(2n+1)^2} \\ (n+2)(2n+1)^2 &\leq 4(n+1)^3 \\ 4n^3 + 12n^2 + 9n + 2 &\leq 4n^3 + 12n^2 + 12n + 4 \\ -2 &\leq 3n.\end{aligned}$$

This last inequality is true for all $n \geq 1$.

14. $2(n+1) + 1 = (2n+1) + 2 \leq 2^n + 2 \leq 2^n + 2^n = 2^{n+1}$

16. By the inductive assumption,

$$(a_1 \cdots a_{2^n})^{1/2^n} \leq \frac{a_1 + \cdots + a_{2^n}}{2^n} \quad (1.1)$$

$$(a_{2^{n+1}} \cdots a_{2^{n+1}})^{1/2^n} \leq \frac{a_{2^{n+1}} + \cdots + a_{2^{n+1}}}{2^n}. \quad (1.2)$$

Let

$$\begin{aligned}A &= \frac{a_1 + \cdots + a_{2^n}}{2^n} \\ B &= \frac{a_{2^{n+1}} + \cdots + a_{2^{n+1}}}{2^n}.\end{aligned}$$

Multiplying inequalities (1.1) and (1.2), we have

$$(a_1 \cdots a_{2^{n+1}})^{1/2^n} \leq AB. \quad (1.3)$$

Applying the Basis Step to the numbers A and B , we have

$$(AB)^{1/2} \leq \frac{A+B}{2}$$

or, equivalently,

$$AB \leq \left[\frac{a_1 + \cdots + a_{2^{n+1}}}{2^{n+1}} \right]^2. \quad (1.4)$$

Combining inequalities (1.3) and (1.4), we have

$$(a_1 \cdots a_{2^{n+1}})^{1/2^n} \leq \left[\frac{a_1 + \cdots + a_{2^{n+1}}}{2^{n+1}} \right]^2.$$

Taking the square root of both sides of the last inequality gives the desired result.

17. $(1+x)^{n+1} = (1+x)^n(1+x)$
 $\geq (1+nx)(1+x)$
 $= 1+nx+x+nx^2$
 $\geq 1+(n+1)x$

19. If we sum the terms in the diagonal direction, we obtain one r , two r^2 's, three r^3 's, and so on; that is, we obtain the sum

$$1 \cdot r^1 + 2 \cdot r^2 + \cdots + nr^n.$$

Multiplying the inequality of Exercise 18 by r yields

$$r^1 + r^2 + \cdots + r^{n+1} < \frac{r}{1-r} \quad \text{for all } n \geq 0. \quad (1.5)$$

Thus, the sum of the entries in the first column is less than $r/(1-r)$. Similarly, the sum of the entries in the second column is less than $r^2/(1-r)$, and so on. It follows from the preceding discussion that

$$1 \cdot r^1 + 2 \cdot r^2 + \cdots + nr^n < \frac{1}{1-r}(r^1 + r^2 + \cdots + r^n).$$

Using inequality (1.5), we obtain the desired result

$$1 \cdot r^1 + 2 \cdot r^2 + \cdots + nr^n < \frac{1}{1-r}(r^1 + r^2 + \cdots + r^n) < \left(\frac{1}{1-r}\right) \left(\frac{r}{1-r}\right) = \frac{r}{(1-r)^2}.$$

20. Take $r = 1/2$ in Exercise 19.
 22. Assume that $11^n - 6$ is divisible by 5.

$$11^{n+1} - 6 = 11^n \cdot 11 - 6 = 11^n(10 + 1) - 6 = 10 \cdot 11^n + 11^n - 6,$$

which is divisible by 5.

23. Suppose that 4 divides $6 \cdot 7^n - 2 \cdot 3^n$. Now

$$\begin{aligned} 6 \cdot 7^{n+1} - 2 \cdot 3^{n+1} &= 7 \cdot 6 \cdot 7^n - 3 \cdot 2 \cdot 3^n \\ &= 6 \cdot 7^n - 2 \cdot 3^n + 6 \cdot 6 \cdot 7^n - 2 \cdot 2 \cdot 3^n \\ &= 6 \cdot 7^n - 2 \cdot 3^n + 36 \cdot 7^n - 4 \cdot 3^n. \end{aligned}$$

Since 4 divides $6 \cdot 7^n - 2 \cdot 3^n$, $36 \cdot 7^n$, and $-4 \cdot 3^n$, it divides their sum, which is $6 \cdot 7^{n+1} - 2 \cdot 3^{n+1}$.

25. $\frac{n}{n+1}$
 27. We use induction on n , the number of lines, to prove the result. If there is one line, the result is certainly true. Suppose that there are $n > 1$ lines. Remove one line. By the inductive hypothesis, the regions that result may be colored red and green so that no two regions that share an edge are the same color. Now restore the removed line. The regions above (or, if the line is vertical, to the left of) the restored line are colored red and green so that no two regions that share an edge are the same color, and the regions below (or, if the line is vertical, to the right of) the restored line are also colored red and green so that no two regions that share an edge are the same color. Now reverse the color of every region below (or, if the line is vertical, to the right of) the restored line. The regions below (or, if the line is vertical, to the right of) the restored line are still colored red and green so that no two regions that share an edge are the same color. Since the colors below the restored line have been reversed, regions that share an edge that is part of the restored line do not have the same color. Therefore the regions may be colored red and green so that no two regions that share an edge are the same color, and the inductive proof is complete.

28. We assume that we proceed around the circle in clockwise order. The proof is by induction on the number n of zeros with the Basis Step, as usual, omitted.

Suppose that the result is true for n zeros, and we are given $n+1$ zeros and $n+1$ ones distributed around a circle. Find a zero followed, in clockwise order, by a one. Temporarily remove these two numbers. By the inductive assumption, it is possible to start at some number and proceed around the circle to the original starting position in such a way that, at any point during the cycle, one has seen at least as many zeros as ones. Notice that this last statement remains true if we restore the removed zero and one.

30. A tromino can cover the square to the left of the missing square as shown

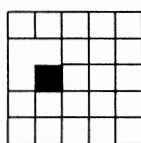

or in a symmetric fashion by reversing “up” and “down.” In the first case, it is impossible to cover the two squares in the top row at the extreme left. In the second case, it is impossible to cover the two squares in the bottom row at the extreme left. Therefore, it is impossible to tile the board with trominoes.

31. Such a board can be tiled with ij 2×3 rectangles of the form



33. By symmetry, we may assume that the missing square is located in the 7×7 subboard shown in the following figure. Exercise 32 shows how to tile this subboard. Exercise 31 shows that the two 6×4 subboards can be tiled. Exercise 29 shows that the 5×5 subboard with a corner square can be tiled. Thus the deficient 11×11 board can be tiled with trominoes.

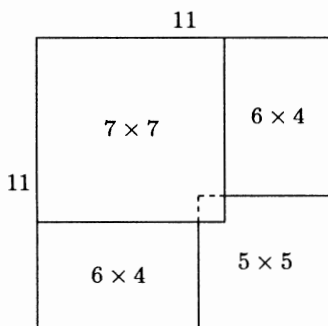

34. Basis Step ($n = 0$). In this case, the $2^n \times 2^n$ L-shape is a tromino and, so, it is tiled.

Inductive Step. Assume that we can tile a $2^{n-1} \times 2^{n-1}$ L-shape with trominoes. Given a $2^n \times 2^n$ L-shape, divide it into four $2^{n-1} \times 2^{n-1}$ L-shapes:

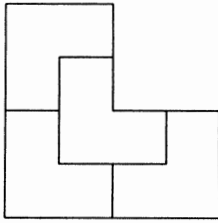

By the inductive assumption, we can tile each of the four $2^{n-1} \times 2^{n-1}$ L-shapes with trominoes. The inductive step is complete.

37. Arguing as in the solution to Exercise 36, the numberings

1	2	3	1	2
3	1	2	3	1
2	3	1	2	3
1	2	3	1	2
3	1	2	3	1

show that the only possibility for the missing square is the center square. This board can be tiled:

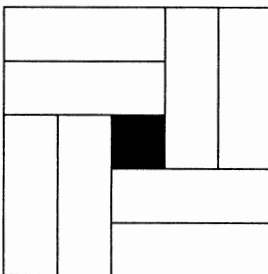

38. An argument like those in the solutions to Exercises 36 and 37 shows that the only board that can be tiled with straight trominoes is the one with the missing square in row 3, column 3 (and the three boards symmetric to it).

40. We show only the inductive step. There are two cases: $a[k] < val$ and $a[k] \geq val$. If $a[k] \geq val$, the value of h does not change. Thus, we still have $a[p] < val$, for all p , $i < p \leq h$. After k is incremented, for all p , $h < p < k$, $a[p] \geq val$.

If $a[k] < val$, then h is incremented and $a[h]$ and $a[k]$ are swapped. Let h_{old} denote the original value of h , and h_{new} denote the new (incremented) value of h . The value at h_{new} is the original $a[k]$. Since this value is less than val , the value of $a[h_{new}]$ is less than val . Thus, for all p , $i < p \leq h_{new}$, $a[p] < val$. After the swap, the value at k becomes h_{new} . By the inductive assumption, this value is greater than or equal to val . Thus after k is incremented, for all p , $h_{new} < p < k$, $a[p] \geq val$.

41. The argument is essentially identical to that of Example 1.7.6 that shows that any $2^n \times 2^n$ deficient board can be tiled with trominoes.

42. Notice that

$$k^3 - 1 = (k - 1)[(k - 2)(k - 4) + 7(k - 1)].$$

Since 7 divides $k^3 - 1$, 7 divides $k - 1$ or $(k - 2)(k - 4) + 7(k - 1)$. If 7 divides the latter expression, 7 also divides $(k - 2)(k - 4)$. If 7 divides $(k - 2)(k - 4)$, 7 divides either $k - 2$ or $k - 4$.

44. The Inductive Step fails if either a or b is 1. In this case, the inductive hypothesis is erroneously applied to the pair $a - 1, b - 1$, which includes a nonpositive integer.
45. To argue by contradiction, one must assume that the proposition fails *for some* $n \geq 2$. The alleged proof assumes that the proposition fails *for all* $n \geq 2$.
46. For $n = 2$, the inequality becomes $\frac{1}{2} + \frac{2}{3} < \frac{4}{3}$, which is true. Thus the Basis Step is true.

Assume that the given statement holds for n . Now

$$\frac{1}{2} + \frac{2}{3} + \cdots + \frac{n}{n+1} + \frac{n+1}{n+2} < \frac{n^2}{n+1} + \frac{n+1}{n+2}.$$

The Inductive Step will be proved provided

$$\frac{n^2}{n+1} + \frac{n+1}{n+2} < \frac{(n+1)^2}{n+2}.$$

If we multiply the last inequality by $(n+1)(n+2)$, we obtain

$$n^2(n+2) + (n+1)^2 < (n+1)^3,$$

which is readily verified as true.

48. In the following figure

• • • •

• •
 a b

a and b are both survivors.

49. Suppose that there are three persons. The two persons closest together throw at each other, and the third person throws at one of the two closest. Therefore the third person survives. This complete the Basis Step.

Suppose that the assertion is true for n , and consider $n + 2$ persons. Again, the closest pair throws at each other. There are now two cases to consider. If the remaining n persons all throw at one another, by the inductive assumption, there is a survivor. If at least one of the remaining n persons throws at one of the closest pair, among the remaining n persons, at most $n - 1$ pies are thrown at one another. In this case, someone survives because there are not enough pies to go around. The Inductive Step is complete.

51. The statement is false. In the following figure

• • • •
 a •

a throws a pie the greatest distance, but is not a survivor.

53. Let x_1 be a common point of X_2, X_3, X_4 ; let x_2 be a common point of X_1, X_3, X_4 ; let x_3 be a common point of X_1, X_2, X_4 ; and let x_4 be a common point of X_1, X_2, X_3 . Since $x_1, x_2, x_3 \in X_4$, the triangle $x_1x_2x_3$ (perimeter and interior) is in X_4 . Similarly, the triangle $x_1x_2x_4$ is in X_3 ; the triangle $x_1x_3x_4$ is in X_2 ; and the triangle $x_2x_3x_4$ is in X_1 . We consider two cases:

CASE 1: One of the points x_1, x_2, x_3, x_4 is in the triangle whose vertices are the other three points. For example, suppose that x_1 is in triangle $x_2x_3x_4$. Since triangle $x_2x_3x_4$ is in X_1 , $x_1 \in X_1$. By definition, $x_1 \in X_2 \cap X_3 \cap X_4$. Therefore, $x_1 \in X_1 \cap X_2 \cap X_3 \cap X_4$.

CASE 2: None of the points x_1, x_2, x_3, x_4 is in the triangle whose vertices are the other three points. In this case, x_1, x_2, x_3, x_4 are the vertices of a convex quadrilateral:

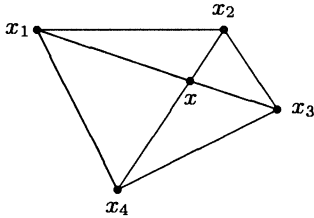

Now the intersection, x , of the diagonals of this quadrilateral belongs to each of the triangles and, thus, to each of X_1, X_2, X_3, X_4 .

54. The proof is by induction on n . The Basis Step is $n = 4$, which is Exercise 53.

We turn to the Inductive Step. Assume that if X_1, \dots, X_n are convex sets, each three of which have a common point, then all n sets have a common point.

Let X_1, \dots, X_n, X_{n+1} be convex sets, each three of which have a common point. We must show that all $n + 1$ sets have a common point. By Exercise 52,

$$X_1, \dots, X_{n-1}, X_n \cap X_{n+1} \tag{1.6}$$

are convex sets. We claim that any three of the sets in (1.6) have a common point. The claim is true by hypothesis if the three sets are any of X_1, \dots, X_{n-1} . Consider $X_i, X_j, X_n \cap X_{n+1}$, $i < j \leq n-1$. By hypothesis, any three of X_i, X_j, X_n, X_{n+1} have a common point. By Exercise 53, X_i, X_j, X_n, X_{n+1} have a common point. Therefore, $X_i, X_j, X_n \cap X_{n+1}$ have a common point. Thus, any three of the sets in (1.6) have a common point. By the inductive assumption, the sets in (1.6) have a common point. The Inductive Step is complete.

56. We first prove the result for $n = 3$. Let A_1, A_2, A_3 be open intervals such that each pair has a nonempty intersection. Choose $x_1 \in A_1 \cap A_2$, $x_2 \in A_1 \cap A_3$, $x_3 \in A_2 \cap A_3$. Note that if any pair $(x_1, x_2$ or x_1, x_3 or $x_3, x_3)$ is equal, it is in $A_1 \cap A_2 \cap A_3$. We may assume $x_1 < x_2$. We consider three cases. First suppose that $x_3 < x_1$. Since $x_2, x_3 \in A_3$, $[x_3, x_2] \subseteq A_3$. ($[a, b]$ is the set of all x satisfying $a \leq x \leq b$.) Thus $x_1 \in A_3$. Therefore $x_1 \in A_1 \cap A_2 \cap A_3$.

Next suppose that $x_1 < x_3 < x_2$. Since $x_1, x_2 \in A_1$, $[x_1, x_2] \subseteq A_1$. Thus $x_3 \in A_1$. Therefore $x_3 \in A_1 \cap A_2 \cap A_3$.

Finally suppose that $x_1 < x_2 < x_3$. Since $x_1, x_3 \in A_2$, $[x_1, x_3] \subseteq A_2$. Thus $x_2 \in A_2$. Therefore $x_2 \in A_1 \cap A_2 \cap A_3$. We have shown that if A_1, A_2, A_3 are open intervals such that each pair has a nonempty intersection, then $A_1 \cap A_2 \cap A_3$ is nonempty.

We now prove that given statement using induction on n . The Basis Step ($n = 2$) is trivial.

Assume that if I_1, \dots, I_n is a set of open intervals such that each pair has a nonempty intersection, then $I_1 \cap \dots \cap I_n$ is nonempty. Let I_1, \dots, I_{n+1} be a set of open intervals such that each pair has a nonempty intersection. Since $I_n \cap I_{n+1}$ is nonempty, it is an open interval. We claim that

$$I_1, \dots, I_{n-1}, I_n \cap I_{n+1}$$

is a set of open intervals such that each pair has a nonempty intersection. This is certainly true for pairs of the form I_i, I_j , $1 \leq i < j \leq n-1$. Consider a pair of the form $I_i, i \leq n-1$, and $I_n \cap I_{n+1}$. Since each pair among I_i, I_n, I_{n+1} has nonempty intersection, by the case $n=3$ proved previously, $I_i \cap I_n \cap I_{n+1}$ is nonempty. Therefore,

$$I_1, \dots, I_{n-1}, I_n \cap I_{n+1}$$

is a set of open intervals such that each pair has a nonempty intersection. By the inductive assumption

$$I_i \cap \dots \cap I_{n-1} \cap (I_n \cap I_{n+1})$$

is nonempty. The inductive step is complete.

58. 5

59. 5

61. After j rounds, $2, 4, \dots, 2j$ have been eliminated. At this point, there are 2^i persons. This is exactly the Josephus problem when the number of persons is a power of 2, except that the round begins with person $2j+1$, rather than with person 1. By Exercise 60, person $2j+1$ is the survivor.

62. 977

65. $\Delta a_n = a_{n+1} - a_n = (n+1)^2 - n^2 = 2n+1$. Let $b_n = \Delta a_n$. Then

$$\begin{aligned} b_1 + b_2 + \dots + b_n &= (2 \cdot 1 + 1) + (2 \cdot 2 + 1) + \dots + (2n + 1) \\ &= 2(1 + 2 + \dots + n) + (1 + 1 + \dots + 1) \\ &= 2(1 + 2 + \dots + n) + n. \end{aligned}$$

By Exercise 64,

$$b_1 + b_2 + \dots + b_n = a_{n+1} - a_1 = (n+1)^2 - 1^2 = n^2 + 2n.$$

Combining the previous equations, we obtain

$$n^2 + 2n = 2(1 + 2 + \dots + n) + n.$$

Solving for $1 + 2 + \dots + n$, we obtain

$$1 + 2 + \dots + n = \frac{n^2 + 2n - n}{2} = \frac{n^2 + n}{2} = \frac{n(n+1)}{2}.$$

66. Let $a_n = n!$. Then

$$\Delta a_n = a_{n+1} - a_n = (n+1)! - n! = n![(n+1) - 1] = n(n!).$$

Let $b_n = \Delta a_n$. Then

$$b_1 + b_2 + \cdots + b_n = 1(1!) + 2(2!) + \cdots + n(n!).$$

By Exercise 64,

$$b_1 + b_2 + \cdots + b_n = a_{n+1} - a_1 = (n+1)! - 1!.$$

Combining the previous equations, we obtain

$$1(1!) + 2(2!) + \cdots + n(n!) = (n+1)! - 1.$$

68. Since p is divisible by k , there exists t_1 such that $p = t_1k$. Since q is divisible by k , there exists t_2 such that $q = t_2k$. Now

$$p + q = t_1k + t_2k = (t_1 + t_2)k.$$

Therefore, $p + q$ is divisible by k .

Problem-Solving Corner: Mathematical Induction

1. The Basis Step ($n = 0$) is $H_1 \leq 1 + 0$. Since $H_1 = 1$, the Basis Step is true.

Now assume that $H_{2^n} \leq 1 + n$. Then

$$\begin{aligned} H_{2^{n+1}} &= H_{2^n} + \frac{1}{2^n + 1} + \cdots + \frac{1}{2^{n+1}} \\ &\leq 1 + n + \frac{1}{2^n + 1} + \cdots + \frac{1}{2^n + 1} \\ &= 1 + n + \frac{2^n}{2^n + 1} \leq 1 + (n + 1). \end{aligned}$$

The Inductive Step is complete.

2. The Basis Step ($n = 1$) is $H_1 = 2H_1 - 1$. Since $H_1 = 1$, the Basis Step is true.

Now assume that

$$H_1 + H_2 + \cdots + H_n = (n + 1)H_n - n.$$

Then

$$\begin{aligned} H_1 + H_2 + \cdots + H_n + H_{n+1} &= (n + 1)H_n - n + H_{n+1} \\ &= (n + 1) \left(H_{n+1} - \frac{1}{n + 1} \right) && \text{by Exercise 3} \\ &\quad - n + H_{n+1} \\ &= (n + 2)H_{n+1} - (n + 1). \end{aligned}$$

The Inductive Step is complete.

$$3. H_{n+1} - \frac{1}{n+1} = \left(\frac{1}{1} + \frac{1}{2} + \cdots + \frac{1}{n} + \frac{1}{n+1} \right) - \frac{1}{n+1} = \frac{1}{1} + \frac{1}{2} + \cdots + \frac{1}{n} = H_n$$

4. We prove the assertion by induction. The Basis Step is $n = 1$:

$$1 \cdot H_1 = 1 = \frac{3}{2} - \frac{1}{2} = \frac{1 \cdot 2}{2} H_2 - \frac{1 \cdot 2}{4}.$$

For the Inductive Step, assume the assertion if true for n . Now

$$\begin{aligned} 1 \cdot H_1 + \cdots + nH_n + (n+1)H_{n+1} &= \frac{n(n+1)}{2} H_{n+1} - \frac{n(n+1)}{4} + (n+1)H_{n+1} \\ &= (n+1)H_{n+1} \left[\frac{n}{2} + 1 \right] - \frac{n(n+1)}{4} \\ &= H_{n+1} \left[\frac{(n+1)(n+2)}{2} \right] - \frac{n(n+1)}{4} \\ &= \left[H_{n+2} - \frac{1}{n+2} \right] \left[\frac{(n+1)(n+2)}{2} \right] \quad \text{by Exercise 3} \\ &\quad - \frac{n(n+1)}{4} \\ &= H_{n+2} \left[\frac{(n+1)(n+2)}{2} \right] - \frac{n+1}{2} - \frac{n(n+1)}{4} \\ &= H_{n+2} \left[\frac{(n+1)(n+2)}{2} \right] - \frac{(n+1)(n+2)}{4}. \end{aligned}$$

Section 1.8

2. Verify directly the cases $n = 24, \dots, 28$. Assume that the statement is true for postage i satisfying $24 \leq i < n$. We must show that we can make n cents postage using only 5-cent and 7-cent stamps. We may assume that $n > 28$. Then $n > n - 5 > 23$. By the inductive assumption, we can make $n - 5$ cents postage using 5-cent and 7-cent stamps. Add a 5-cent stamp to obtain n cents postage.
4. The Basis Step ($n = 6$) is proved by using three 2-cent stamps. Now assume that we can make postage for n cents. If there is at least one 7-cent stamp, replace it by four 2-cent stamps to make $n + 1$ cents postage. If there are no 7-cent stamps, there are at least three 2-cent stamps (because $n \geq 6$). Replace three 2-cent stamps by one 7-cent stamp to make $n + 1$ cents postage. The Inductive Step is complete.
5. The Basis Step ($n = 24$) is proved by using two 5-cent stamps and two 7-cent stamps. Now assume that we can make postage for n cents. If there are at least two 7-cent stamps, replace two 7-cent stamps with three 5-cent stamps to make $n + 1$ cents postage. If there is exactly one 7-cent stamp, then there are at least four 5-cent stamps (because $n \geq 24$). Replace one 7-cent stamp and four 5-cent stamps with four 7-cent stamps to make $n + 1$ cents postage. If there are no 7-cent stamps, then there are at least five 5-cent stamps (again because $n \geq 24$). Replace five 5-cent stamps with three 7-cent stamps and one 5-cent to make $n + 1$ cents postage. The Inductive Step is complete.

7. We omit the Basis Step. For the Inductive Step, we have

$$c_n = c_{\lfloor n/2 \rfloor} + n^2 < 4 \left\lfloor \frac{n}{2} \right\rfloor^2 + n^2 \leq 4 \left(\frac{n}{2} \right)^2 + n^2 = 2n^2 < 4n^2.$$

9. We omit the Basis Step. For the Inductive Step, we have

$$\begin{aligned} c_n = 4c_{\lfloor n/2 \rfloor} + n &\leq 4[4(\lfloor n/2 \rfloor - 1)^2] + n \\ &\leq 4[4(n/2 - 1)^2] + n \\ &= 4n^2 - 16n + 16 \\ &\leq 4(n - 1)^2. \end{aligned}$$

The last inequality reduces to $12 \leq 7n$, which is true since $n > 1$.

10. We omit the Basis Steps ($n = 2, 3$). We turn to the Inductive Step. Assume that $n \geq 4$. Then $n/2 \geq 2$, so $\lfloor n/2 \rfloor \geq 2$. Then

$$\begin{aligned} c_n = 4c_{\lfloor n/2 \rfloor} + n &> 4(\lfloor n/2 \rfloor + 1)^2/8 + n \\ &\geq 4[(n - 1)/2 + 1]^2/8 + n \\ &= (n + 1)^2/8 + n \\ &> (n + 1)^2/8. \end{aligned}$$

We used the fact that $\lfloor n/2 \rfloor \geq (n - 1)/2$ for all n .

13. $q = -6, r = 7$

14. $q = 0, r = 7$

16. $q = 0, r = 0$

17. $q = 1, r = 0$

19. If

$$\frac{p}{q} = \frac{1}{n_1} + \frac{1}{n_2} + \cdots + \frac{1}{n_k}$$

where $n_1 < n_2 < \cdots < n_k$, another representation is

$$\frac{p}{q} = \frac{1}{n_1} + \frac{1}{n_2} + \cdots + \frac{1}{n_{k-1}} + \frac{1}{n_k + 1} + \frac{1}{n_k(n_k + 1)}$$

20. (b) Since $p/q < 1$, $n > 1$. Since n is the smallest positive integer satisfying $1/n \leq p/q$ and $n - 1$ is a positive integer less than n , $p/q < 1/(n - 1)$.

(d) We have

$$\frac{p_1}{q_1} = \frac{np - q}{nq} = \frac{p}{q} - \frac{1}{n}. \quad (1.7)$$

Since $1/n < p/q$, equation (1.7) shows that

$$0 < \frac{p_1}{q_1}.$$

Since

$$\frac{p}{q} < \frac{1}{n-1},$$

we have

$$np - p < q$$

or

$$p_1 = np - q < p.$$

The third inequality is established.

Now

$$\frac{p_1}{q_1} < \frac{p}{q_1} = \frac{p}{nq} = \frac{1}{n} \frac{p}{q} < \frac{1}{n} \cdot 1 = \frac{1}{n}. \tag{1.8}$$

In particular,

$$\frac{p_1}{q_1} < 1.$$

We have established the second inequality.

By the inductive assumption, p_1/q_1 can be expressed in Egyptian form. The last equation follows.

(e) See (1.8).

(f) The equation is true because of (d). For any $i = 1, \dots, k$,

$$\frac{1}{n_i} \leq \frac{1}{n_1} + \dots + \frac{1}{n_k} = \frac{p_1}{q_1} < \frac{1}{n}.$$

It follows that n, n_1, \dots, n_k are distinct.

21. $\frac{3}{8} = \frac{1}{3} + \frac{1}{24}, \frac{5}{7} = \frac{1}{2} + \frac{1}{5} + \frac{1}{70}, \frac{13}{19} = \frac{1}{2} + \frac{1}{6} + \frac{1}{57}$

24. Enclose the missing square in a corner $(n-3) \times (n-3)$ subboard as shown in the following figure. Since 3 divides $n^2 - 1$, 3 also divides $(n-3)^2 - 1$. Now $n-3$ is odd, $n-3 > 5$, and 3 divides $(n-3)^2 - 1$, so by Exercise 23, we may tile this subboard. Tile the two $3 \times (n-4)$ subboards using the result of Exercise 31, Section 1.7. Tile the deficient 4×4 subboard using Example 1.7.6. The $n \times n$ board is tiled.

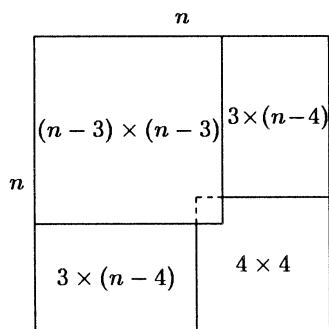

25. If $n = 0$, $d \cdot 1 = d > 0$, and 1 is in X . If $n > 0$, $d(2n) = n(2d) > n$; thus $2n$ is in X . In either case X is nonempty. Since $d > 0$ and $n \geq 0$, X contains only positive integers. By the Well-Ordering Property, X contains a least element $q' > 0$. Then $dq' > n$. Let $q = q' - 1$. We cannot have $dq > n$ (for then q' would not be the *least* element in X); therefore, $dq \leq n$. Let $r = n - dq$. Then $r \geq 0$. Also

$$r = n - dq = n - d(q' - 1) < dq' - d(q' - 1) = d.$$

Therefore, we have found q and r satisfying

$$n = dq + r \quad 0 \leq r < d.$$

26. We first prove Theorem 1.8.5 for $n > 0$. The Basis Step is $n = 1$. If $d = 1$, we have $n = dq + r$, where $q = n$ and $r = 0$, $0 \leq r < d$. If $d > 1$, we have $n = dq + r$, where $q = 0$ and $r = 1$, $0 \leq r < d$. Thus Theorem 1.8.5 is true for $n = 1$.

Assume that Theorem 1.8.5 holds for n . Then there exists q' and r' such that

$$n = dq' + r' \quad 0 \leq r' < d.$$

Now

$$n + 1 = dq' + (r' + 1).$$

If $r' < d - 1$, then $r' + 1 < d$. In this case, if we take $q = q'$ and $r = r' + 1$, we have

$$n + 1 = dq + r \quad 0 \leq r < d.$$

If $r' = d - 1$, we have

$$n + 1 = d(q' + 1).$$

In this case, if we take $q = q' + 1$ and $r = 0$, we have

$$n + 1 = dq + r \quad 0 \leq r < d.$$

The Inductive Step is complete. Therefore, Theorem 1.8.5 is true for all $n > 0$.

If $n = 0$, we may write

$$n = dq + r,$$

where $q = r = 0$. Therefore, Theorem 1.8.5 is true for $n = 0$.

Finally, suppose that $n < 0$. Then $-n > 0$, so by the first part of the proof, there exist q' and r' such that

$$-n = dq' + r' \quad 0 \leq r' < d.$$

If $r' = 0$, we may take $q = -q'$ and $r = 0$ to obtain

$$n = dq + 0.$$

If $r' > 0$, we take $q = -q' - 1$ and $r = d - r'$. Then $0 < r < d$ and

$$n = d(-q') - r' = d(q + 1) + (r - d) = dq + r.$$

Therefore, Theorem 1.8.5 is true for $n < 0$.

28. Suppose that we have a propositional function $S(n)$ whose domain of discourse is the set of integers greater than or equal to n_0 . Suppose that $S(n_0)$ is true and, for all $n > n_0$, if $S(k)$ is true for all k , $n_0 \leq k < n$, then $S(n)$ is true. We must prove that $S(n)$ is true for every integer $n \geq n_0$. We first assume that $n_0 \geq 0$.

We argue by contradiction. So assume that $S(n)$ is false for some integer $n_1 \geq n_0$. Let X be the set of nonnegative integers for which $S(n)$ is false. Then X is nonempty. By the Well-Ordering Property, X has a least element n_2 . Since $S(n_0)$ is true, $n_2 > n_0$. Furthermore, for any k , $n_0 \leq k < n_2$, $S(k)$ is true [otherwise n_2 would not be the least integer n for which $S(n)$ is false]. Since $S(k)$ is true for all k , $n_0 \leq k < n_2$, by hypothesis, $S(n_2)$ is true. Contradiction.

If $n_0 < 0$, apply the previous argument to the propositional function

$$S'(n): S(n + n_0)$$

with domain of discourse the set of nonnegative integers.

29. The strong form of induction clearly implies the form of induction where the Inductive Step is: "If $S(n)$ is true, then $S(n + 1)$ is true." For the converse, use Exercises 27 and 28.

Chapter 2

Solutions to Selected Exercises

Section 2.1

2. $\{2, 4\}$ 3. $\{7, 10\}$ 5. $\{2, 3, 5, 6, 8, 9\}$ 6. $\{1, 3, 5, 7, 9, 10\}$

8. A 9. \emptyset 11. B 12. $\{1, 4\}$ 14. $\{1\}$

15. $\{2, 3, 4, 5, 6, 7, 8, 9, 10\}$

18.

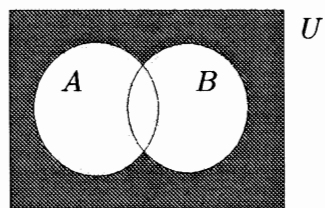

19.

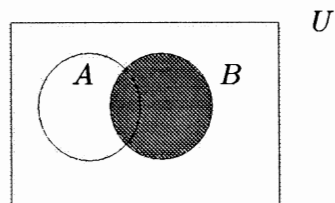

21.

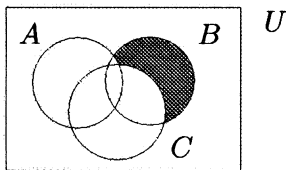

22.

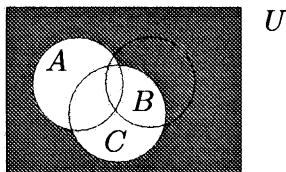

24.

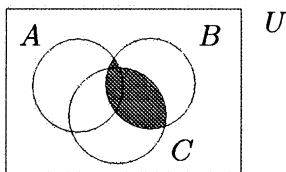

26. 32

27. 105

29. 51

31. Suppose that n students are taking both a mathematics course and a computer science course. Then $4n$ students are taking a mathematics course, but not a computer science course, and $7n$ students are taking a computer science course, but not a mathematics course. The following Venn diagram depicts the situation:

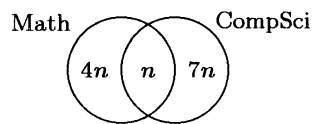

Thus, the total number of students is

$$4n + n + 7n = 12n.$$

The proportion taking a mathematics course is

$$\frac{5n}{12n} = \frac{5}{12},$$

which is greater than one-third.

33. $\{(a, 1), (a, 2), (b, 1), (b, 2), (c, 1), (c, 2)\}$ 34. $\{(1, 1), (1, 2), (2, 1), (2, 2)\}$ 37. $\{(1, a, a), (2, a, a)\}$

38. $\{(1, 1, 1), (1, 2, 1), (2, 1, 1), (2, 2, 1), (1, 1, 2), (1, 2, 2), (2, 1, 2), (2, 2, 2)\}$

41. $\{1, 2\}$
 $\{1\}, \{2\}$

42. $\{a, b, c\}$
 $\{a, b\}, \{c\}$
 $\{a, c\}, \{b\}$
 $\{b, c\}, \{a\}$
 $\{a\}, \{b\}, \{c\}$

45. False 46. True 49. Equal 50. Equal 52. Not equal

54. $\emptyset, \{a\}, \{b\}, \{c\}, \{d\}, \{a, b\}, \{a, c\}, \{a, d\}, \{b, c\}, \{b, d\}, \{c, d\}, \{a, b, c\}, \{a, b, d\},$
 $\{a, c, d\}, \{b, c, d\}, \{a, b, c, d\}$

55. $2^{10} = 1024; 2^{10} - 1 = 1023$ 57. $X = Y$ 59. True 60. True

62. False. Take $X = \{1, 2\}, Y = \{2, 3\}, U = \{1, 2, 3\}$.

63. False. Take $U = \{1, 2, 3, 4, 5\}, X = \{2, 3\}, Y = \{3, 4\}$. 65. True

66. False. Take $U = \{1, 2\}, X = \{1\}, Y = \{2\}$.

68. False. Take $X = \{1, 2\}, Y = \{1\}, Z = \{2\}$.

69. False. Take $X = \{1, 2\}, Y = \{1, 3\}, Z = \{1, 4\}$.

72. $B \subseteq A$ 73. $A = U$

76. The symmetric difference of two sets consists of the elements in one or the other but not both.

77. $A \Delta A = \emptyset, A \Delta \bar{A} = U, U \Delta A = \bar{A}, \emptyset \Delta A = A$

78. The statement is true. We first prove that $A \subseteq B$. Let $x \in A$.

We divide the proof into two cases. First, we consider the case that $x \in C$. Then $x \notin A \Delta C$. Therefore $x \notin B \Delta C$. Therefore $x \in B$ (since if $x \notin B$, then $x \in B \Delta C$).

Next, we consider the case that $x \notin C$. Then $x \in A \Delta C$. Therefore $x \in B \Delta C$. Therefore $x \in B \cup C$. Therefore $x \in B$.

In either case, $x \in B$, and so $A \subseteq B$. Similarly, $B \subseteq A$, and so $A = B$.

80. $|A \cup B \cup C| = |A| + |B| + |C| - |A \cap B| - |A \cap C| - |B \cap C| + |A \cap B \cap C|$

81. The center of C

83–93. Argue as in the proof given in the book of the first distributive law [Theorem 2.1.12, part (c)].

94. We prove part (a) only. The Basis Step is immediate.

Assume that

$$X \cap (X_1 \cup X_2 \cup \cdots \cup X_n) = (X \cap X_1) \cup (X \cap X_2) \cup \cdots \cup (X \cap X_n).$$

We must prove that

$$X \cap (X_1 \cup X_2 \cup \cdots \cup X_n \cup X_{n+1}) = (X \cap X_1) \cup (X \cap X_2) \cup \cdots \cup (X \cap X_n) \cup (X \cap X_{n+1}).$$

Let $Y = X_n \cup X_{n+1}$. By the inductive assumption,

$$X \cap (X_1 \cup X_2 \cup \cdots \cup X_{n-1} \cup Y) = (X \cap X_1) \cup (X \cap X_2) \cup \cdots \cup (X \cap X_{n-1}) \cup (X \cap Y).$$

By the associative law,

$$X \cap (X_1 \cup X_2 \cup \cdots \cup X_{n-1} \cup Y) = X \cap (X_1 \cup X_2 \cup \cdots \cup X_n \cup X_{n+1}).$$

By the distributive law,

$$X \cap Y = X \cap (X_n \cup X_{n+1}) = (X \cap X_n) \cup (X \cap X_{n+1}).$$

Therefore

$$(X \cap X_1) \cup (X \cap X_2) \cup \cdots \cup (X \cap X_{n-1}) \cup (X \cap Y) = (X \cap X_1) \cup (X \cap X_2) \cup \cdots \cup (X \cap X_n) \cup (X \cap X_{n+1}),$$

and the Inductive Step is complete.

Section 2.2

2. Not a function

3. It is a function from X to Y ; domain = X , range = Y ; it is both one-to-one and onto. Its arrow diagram is

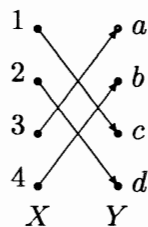

The inverse function is

$$\{(c, 1), (d, 2), (a, 3), (b, 4)\}.$$

For the inverse function, domain = Y , range = X . Its arrow diagram is

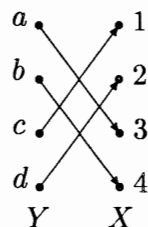

5. It is a function from X to Y ; domain = X , range = $\{b\}$. Its arrow diagram is

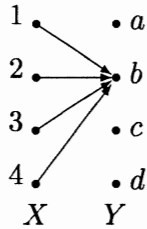

It is neither one-to-one nor onto.

7.

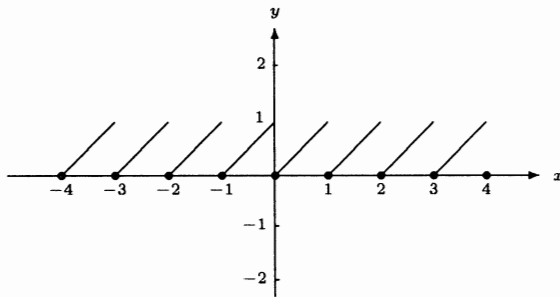

8.

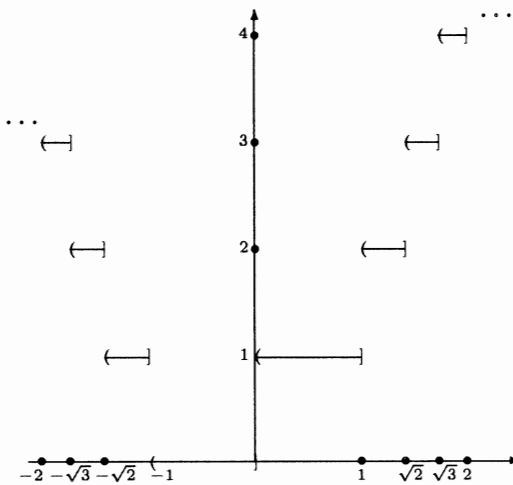

11. Not one-to-one. $f(4/3) = f(-2/3)$. Not onto. $f(x) \neq 0$ for any real x .

12. Not one-to-one. $\sin 0 = \sin 2\pi$. Not onto. $\sin x \neq 2$ for any real x .

14. One-to-one. Not onto. $f(x) \neq -2$ for any real x .

15. Not one-to-one. Notice that $f(x) = f(1/x)$. Thus any value of x , $x \neq 0$, $x \neq 1$, shows that f is not one-to-one. Not onto. $f(x) \neq 1$ for any real x . (In fact, $-1/2 \leq f(x) \leq 1/2$ for all real x .)

17. Let f be the function from $X = \{a, b\}$ to $Y = \{y\}$ given by $f = \{(a, y), (b, y)\}$.

18. The function $\{(1, 1), (2, 1)\}$ from $\{1, 2\}$ to $\{1, 2\}$.

20. $f^{-1}(y) = \log_3 y$ 21. $f^{-1}(y) = 2^{y/3}$ 23. $f^{-1}(y) = \left(\frac{y+5}{4}\right)^{1/3}$
24. $f^{-1}(y) = [\log_2(y-6) + 1]/7$
26. $(f \circ f)(x) = 2(2n+1) + 1$, $(g \circ g)(x) = 3(3n-1) - 1$, $(f \circ g)(x) = 2(3n-1) + 1$, $(g \circ f)(x) = 3(2n+1) - 1$
27. $(f \circ f)(x) = n^4$, $(g \circ g)(x) = 2^{2^n}$, $(f \circ g)(x) = 2^{2^n}$, $(g \circ f)(x) = 2^{n^2}$
30. $g(x) = 1/x$, $h(x) = 2x$, $w(x) = x^2$, $(g \circ h \circ w)(x) = f(x)$
31. $g(x) = 2x$, $h(x) = \sin x$, $f(x) = (h \circ g)(x)$
33. $g(x) = x^4$, $h(x) = 3 + x$, $w(x) = \sin x$, $(g \circ h \circ w)(x) = f(x)$
34. $g(x) = 1/x^3$, $h(x) = 6x$, $t(x) = \cos x$, $f(x) = (g \circ t \circ h)(x)$
36. 4; one-to-one functions: $\{(1, a), (2, b)\}$ and $\{(1, b), (2, a)\}$. In this case, the onto and one-to-one functions are the same.
37. (a) $f \circ f = \{(a, a), (b, b), (c, a)\}$, $f \circ f \circ f = \{(a, b), (b, a), (c, b)\}$
 (b) $f^9 = f$, $f^{623} = f$
39. $f = \{(0, 0), (1, 4), (2, 2), (3, 0), (4, 4), (5, 2)\}$. f is neither one-to-one nor onto. The arrow diagram of f is

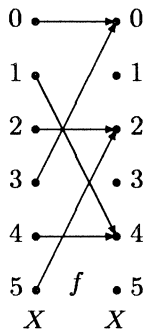

43. $714 : 0, 631 : 2, 26 : 9, 373 : 16, 775 : 10, 906 : 5, 509 : 1, 2032 : 11, 42 : 8, 4 : 4, 136 : 3, 1028 : 12$
44. $53 : 4, 13 : 5, 281 : 3, 743 : 6, 377 : 9, 20 : 7, 10 : 1, 796 : 8$
46. During a search if we stop the search at an empty cell, we may not find the item even if it is present. The cell may be empty because an item was deleted. One solution is to mark deleted cells and consider them nonempty during a search.
47. No. If the data item is present, it will be found before an empty cell is encountered.
50. False. Let $X = \{1\}$, $Y = \{a, b\}$, $Z = \{\alpha, \beta\}$. A counterexample is $f = \{(a, \alpha), (b, \beta)\}$, $g = \{(1, a)\}$.
51. False. Let $X = \{1, 2\}$, $Y = \{a, b\}$, $Z = \{\alpha, \beta\}$. A counterexample is $f = \{(a, \alpha), (b, \alpha)\}$, $g = \{(1, a), (2, b)\}$.

53. True
54. False. Let $X = \{1\}$, $Y = \{a, b\}$, $Z = \{\alpha\}$. A counterexample is $f = \{(a, \alpha), (b, \alpha)\}$, $g = \{(1, a)\}$.
56. True. Let $z \in Z$. Since $f \circ g$ is onto, there exists $x \in X$ such that $f(g(x)) = z$. Let $y = g(x)$. Then $f(y) = z$. Therefore f is onto Z .
58. Suppose that f is not one-to-one. Then, for some x and y , $f(x) = f(y)$, but $x \neq y$. Let $A = \{x\}$, $B = \{y\}$.
- Suppose that f is one-to-one. Let $y \in f(A \cap B)$. Then $y = f(x)$ for some $x \in A \cap B$. Thus $y \in f(A) \cap f(B)$. Let $y \in f(A) \cap f(B)$. Then $y = f(a) = f(b)$, for some $a \in A$, $b \in B$. Since f is one-to-one, $a = b$. Therefore, $y \in f(A \cap B)$.
59. [The case: If g is one-to-one, then $f \circ g$ is one-to-one implies that f is one-to-one.]
- Suppose that f is not one-to-one. Then there exist distinct $x_1, x_2 \in X$ with $f(x_1) = f(x_2)$. Let $A = \{1, 2\}$, and let $g = \{(1, x_1), (2, x_2)\}$. Now g is one-to-one, but $f \circ g$ is not one-to-one, which is a contradiction.
60. Suppose that f is onto Y . Let g be a function from Y onto Z . We must show that $g \circ f$ is onto Z . Let $z \in Z$. Since g is onto Z , there exists $y \in Y$, with $g(y) = z$. Since f is onto Y , there exists $x \in X$, with $f(x) = y$. Now $g \circ f(x) = z$. Therefore, $g \circ f$ is onto.
- Suppose that whenever g is a function from Y onto Z , $g \circ f$ is onto Z . Suppose that f is not onto Y . Then there exists $y_0 \in Y$ such that for no $x \in X$ do we have $f(x) = y_0$. Let $Z = \{0, 1\}$. Define g from Y to Z by $g(y_0) = 1$, and $g(y) = 0$ if $y \neq y_0$. Then g is onto Z , but $g \circ f$ is not onto Z .
61. If $x \in X$, then $x \in f^{-1}(f(\{x\}))$. Thus $\cup\{S \mid S \in \mathcal{S}\} = X$.

Suppose that

$$a \in f^{-1}(\{y\}) \cap f^{-1}(\{z\})$$

for some $y, z \in Y$. Then $f(a) = y$ and $f(a) = z$. Thus $y = z$. Therefore, \mathcal{S} is a partition of X .

63. If $x \in X - Y$, then

$$C_{X \cup Y}(x) = 1 = 1 + 0 - 1 \cdot 0 = C_X(x) + C_Y(x) - C_X(x)C_Y(x).$$

Similarly, if $x \in Y - X$, the equation holds. If $x \in X \cap Y$, then

$$C_{X \cup Y}(x) = 1 = 1 + 1 - 1 \cdot 1 = C_X(x) + C_Y(x) - C_X(x)C_Y(x).$$

If $x \notin X \cup Y$, then

$$C_{X \cup Y}(x) = 0 = 0 + 0 - 0 \cdot 0 = C_X(x) + C_Y(x) - C_X(x)C_Y(x).$$

Thus the equation holds for all $x \in U$.

64. If $x \in X$, then $x \notin \overline{X}$; thus,

$$C_{\overline{X}}(x) = 0 = 1 - 1 = 1 - C_X(x).$$

If $x \notin X$, then $x \in \overline{X}$; thus,

$$C_{\overline{X}}(x) = 1 = 1 - 0 = 1 - C_X(x).$$

66. If $C_X(x) = 0$, the inequality obviously holds. If $C_X(x) = 1$, then $x \in X$. Since $X \subseteq Y$, $x \in Y$. Thus $C_Y(x) = 1$ also. Again, the inequality holds.

67. $C_{X \Delta Y}(x) = C_X(x) + C_Y(x) - 2C_X(x)C_Y(x)$

69. Suppose that there is a one-to-one function f from X to Y . Let R be the range of f and choose $a \in X$. If $y \in R$, let $g(y) = f^{-1}(y)$. If $y \in Y - R$, let $g(y) = a$. Then g is a function from Y onto X .

Suppose that there is a function g from Y onto X . For each $x \in X$, choose one $y \in Y$ with $g(y) = x$. Define $f(x) = y$. Then f is a one-to-one function from X to Y .

71. f is not a binary operator since the range of f is not contained in X .

72. f is a commutative, binary operator.

74. f is a commutative, binary operator. To see this, note that if $x, y \in X$, then $1 \leq xy$. Now

$$0 \leq (x - y)^2 = x^2 - 2xy + y^2;$$

hence,

$$1 \leq xy \leq x^2 - xy + y^2 = f(x, y).$$

76. $f(X) = X \cup \{1\}$

77. Let R denote the set

$$\{(y, x) \mid (x, y) \in f\}.$$

The set of y such that $(y, x) \in R$ is Y since f is onto. If $(y, x), (y, x') \in R$, then $x = x'$ since f is one-to-one. Thus R is a function from Y to X .

For each $x \in X$, there is exactly one $y \in Y$ with $R(y) = x$ since f is a function. Therefore R is one-to-one and onto.

79. False. A counterexample is $x = y = 1.5$.

80. False. A counterexample is $x = 2, y = 2.6$.

82. Since n is an odd integer, $n = 2k + 1$ for some integer k . Now

$$\left\lceil \frac{n^2}{4} \right\rceil = \left\lceil \frac{4k^2 + 4k + 1}{4} \right\rceil = \left\lceil k^2 + k + \frac{1}{4} \right\rceil = k^2 + k + 1,$$

and

$$\frac{n^2 + 3}{4} = \frac{(4k^2 + 4k + 1) + 3}{4} = k^2 + k + 1.$$

83. $x = 1.5$

87. August

Section 2.3

4. 5 5. 13 6. 199 7. 4153 8. 9 9. 45 10. 15
11. 3465 12. $s_n = 2(n+1) - 1$ 13. Yes 14. No 15. No
16. Yes 17. 8 18. 26 19. 41 20. 8 21. Yes 22. No
23. No 24. Yes 31. No 32. No 33. Yes 34. Yes
35. Yes 36. Yes 37. Yes 38. Yes 51. 2 52. 5
53. $c_n = n/2$, if n is even; $c_n = (n-1)/2 - n$, if n is odd.
54. $d_n = (-1)^{n/2}n!$, if n is even; $d_n = (-1)^{(n+1)/2}n!$, if n is odd.
55. No 56. No 57. No 58. No 59. 9 60. 30
61. $3n$ 62. 3^n 63. No 64. No 65. Yes 66. Yes
74. $3/4$ 75. $10/11$ 76. $1 - 1/(n+1)$ 77. $1/[(n+1)(n!)^2]$ 78. No
79. Yes 80. Yes 81. No 82. $3^n n!$ 87. $2^1, 2^2, 2^3, 2^4, 2^5, 2^6, 2^7$
88. $2^1, 2^2, 2^4, 2^7, 2^{11}, 2^{16}, 2^{22}$ 89. $n_k = \frac{k(k-1)+2}{2}$ 90. $t_{n_k} = 2^{n_k} = 2^{[k(k-1)+2]/2}$
95. -1 96. -14 97. -88 98. -476 99. $3 \cdot 2^p - 4 \cdot 5^p$
100. $3 \cdot 2^{n-1} - 4 \cdot 5^{n-1}$ 101. $3 \cdot 2^{n-2} - 4 \cdot 5^{n-2}$
102. $7r_{n-1} - 10r_{n-2}$
 $= 7(3 \cdot 2^{n-1} - 4 \cdot 5^{n-1}) - 10(3 \cdot 2^{n-2} - 4 \cdot 5^{n-2})$
 $= 3(7 \cdot 2^{n-1} - 10 \cdot 2^{n-2}) - 4(7 \cdot 5^{n-1} - 10 \cdot 5^{n-2})$
 $= 3\left(\frac{7}{2}2^n - \frac{10}{4}2^n\right) - 4\left(\frac{7}{5}5^n - \frac{10}{25}5^n\right)$
 $= 3 \cdot 2^n - 4 \cdot 5^n = r_n$
103. 2 104. 9 105. 36 106. 135 107. $(2+i)3^i$ 108. $(1+n)3^{n-1}$
109. $n3^{n-2}$
110. $6z_{n-1} - 9z_{n-2} = 6(1+n)3^{n-1} - 9(n3^{n-2}) = 2(1+n)3^n - n3^n$
 $= 3^n[2(1+n) - n] = (2+n)3^n = z_n$
112. $\sum_{k=0}^{n-1} (k+1)^2 r^{n-k-1}$ 113. $\sum_{i=0}^{n-1} C_i C_{n-i-1}$
115. The first sum is the sum by rows of the matrix

$$\begin{pmatrix} a_{11} & a_{12} & a_{13} & \cdots & a_{1n} \\ & a_{22} & a_{23} & \cdots & a_{2n} \\ & & & \ddots & \\ & & & & a_{nn} \end{pmatrix},$$

and the second sum is the sum by columns of the same array. Thus the two sums are equal.

116. (a) *baabcaaba* (b) *caababaab* (c) *baabbaab* (d) *caabacaaba*
 (e) 9 (f) 9 (g) 8 (h) 10 (i) *baab* (j) *caaba*
 (k) *baabcaababbab* (l) *caabacaababbabbaab*

118. $\lambda, 0, 1, 00, 01, 10, 11$ 119. $000, 001, 010, 011, 100, 101, 110, 111$

121. $\lambda, b, a, c, ba, ab, bc, bab, abc, babc$

122. $\lambda, a, b, aa, ab, ba, bb, aab, aba, baa, abb, aaba, abaa, baab, aabb, aabaa, abaab, baabb, aabaab, abaabb, aabaabb$

123. Basis Step ($n = 1$). In this case, $\{1\}$ is the only nonempty subset of $\{1\}$, so the sum is

$$\frac{1}{1} = 1 = n.$$

Inductive Step. Assume that the statement is true for n . We divide the subsets of

$$\{1, \dots, n, n+1\}$$

into two classes:

$$\begin{aligned} C_1 &= \text{class of nonempty subsets that do not contain } n+1 \\ C_2 &= \text{class of subsets that contain } n+1. \end{aligned}$$

By the inductive assumption,

$$\sum_{C_1} \frac{1}{n_1 \cdots n_k} = n.$$

Since a set in C_2 consists of $n+1$ together with a subset (empty or nonempty) of $\{1, \dots, n\}$,

$$\sum_{C_2} \frac{1}{(n+1)n_1 \cdots n_k} = \frac{1}{n+1} + \frac{1}{n+1} \sum_{C_1} \frac{1}{n_1 \cdots n_k}.$$

[The term $1/(n+1)$ results from the subset $\{n+1\}$.] By the inductive assumption,

$$\frac{1}{n+1} + \frac{1}{n+1} \sum_{C_1} \frac{1}{n_1 \cdots n_k} = \frac{1}{n+1} + \frac{1}{n+1} \cdot n = 1.$$

Therefore,

$$\sum_{C_2} \frac{1}{(n+1)n_1 \cdots n_k} = 1.$$

Finally,

$$\sum_{C_1 \cup C_2} \frac{1}{n_1 \cdots n_k} = \sum_{C_1} \frac{1}{n_1 \cdots n_k} + \sum_{C_2} \frac{1}{(n+1)n_1 \cdots n_k} = n + 1.$$

125. Taking $\alpha = \lambda$, the first rule tells us that $a\alpha b = ab \in L$ and $b\alpha a = ba \in L$. Taking $\alpha = ba$ and $\beta = ab$, the second rule tells us that $\alpha\beta = baab \in L$. Finally, taking $\alpha = baab$ and $\beta = ab$, the second rule tells us that $\alpha\beta = baabab \in L$.
126. Exercise 127 shows that if $\alpha \in L$, α has equal numbers of a 's and b 's. Since aab has more a 's than b 's, aab is not in L .
128. We use strong induction on the length n of α to show that if α has equal numbers of a 's and b 's, then $\alpha \in L$. The Basis Step is $n = 0$. In this case, α is the null string, and the null string is in L by the definition of L .

Suppose that α has length $n > 0$, and α has equal numbers of a 's and b 's. Notice that, because of the first rule, the length of α is at least two. First suppose that α starts with a and ends with b , that is, $\alpha = a\beta b$. Then β has length less than n , and β has equal numbers of a 's and b 's. By the inductive assumption, $\beta \in L$. By the first rule, $\alpha = a\beta b \in L$. Similarly, if α starts with b and ends with a , then $\alpha \in L$.

Now suppose that α has equal numbers of a 's and b 's and α starts with a and ends with a , that is, $\alpha = a\beta a$. We claim that some proper substring of α starting at the beginning contains equal numbers of a 's and b 's; that is, we claim that $\alpha = \gamma\delta$, where γ and δ have equal numbers of a 's and b 's, and neither γ nor δ is the null string. Assuming that this claim is true, by the inductive assumption γ and δ are in L , and it follows from the second rule that $\alpha \in L$. The Inductive Step is complete.

To prove the claim, for each substring ε of α starting at the beginning, consider

$$\text{val}(\varepsilon) = \text{number of } a\text{'s} - \text{number of } b\text{'s}.$$

Consider $\text{val}(\varepsilon)$ for substrings ε of increasing length. For the first substring, a , $\text{val}(a) = 1$. For the next-to-last substring (α with the trailing a omitted), we have $\text{val}(\varepsilon) = -1$. When the length of the substring increases by one, $\text{val}(\varepsilon)$ increases or decreases by one. Since val 's first value is 1 and its last value is -1 , for some substring β , $\text{val}(\beta) = 0$. Thus β has equal numbers of a 's and b 's, and the claim is proved.

Chapter 3

Solutions to Selected Exercises

Section 3.1

2. $\{(a, 3), (b, 1), (b, 4), (c, 1)\}$

3. $\{(Sally, Math), (Ruth, Physics), (Sam, Econ)\}$

6.

Roger	Music
Pat	History
Ben	Math
Pat	PolySci

7.

1	1
2	1
3	1
4	1
2	2
3	2
4	2
2	3
3	3
4	3
2	4
3	4
4	4

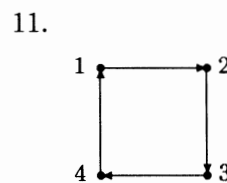
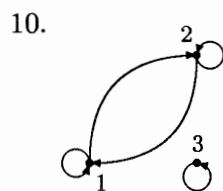

14. $\{(1, 1), (2, 2), (3, 3), (3, 5), (4, 3), (4, 4), (5, 5), (5, 4)\}$

15. \emptyset

18. (Exercise 1) $\{(Hammer, 8840), (Pliers, 9921), (Paint, 452), (Carpet, 2207)\}$

20. $\{(1, 1), (4, 1), (2, 2), (5, 2), (3, 3), (1, 4), (4, 4), (2, 5), (5, 5)\}$

21. $\{1, 2, 3, 4, 5\}$ 23. $\{1, 2, 3, 4, 5\}$ 24. $\{1, 2, 3, 4, 5\}$
26. $R = \{(1, 2), (2, 3), (3, 4), (4, 5)\}$
 $R^{-1} = \{(2, 1), (3, 2), (4, 3), (5, 4)\}$
domain of $R = \{1, 2, 3, 4\}$
range of $R = \{2, 3, 4, 5\}$
domain of $R^{-1} = \{2, 3, 4, 5\}$
range of $R^{-1} = \{1, 2, 3, 4\}$
27. Symmetric 30. Antisymmetric, transitive
31. Reflexive, antisymmetric, transitive, partial order
33. Reflexive, symmetric, transitive 34. Reflexive, symmetric, transitive
36. Reflexive, symmetric
37. Reflexive: Suppose that (x_1, x_2) is in $X_1 \times X_2$. Since R_i is reflexive, $x_1 R_1 x_1$ and $x_2 R_2 x_2$. Thus $(x_1, x_2) R(x_1, x_2)$.
Antisymmetric: Suppose that $(x_1, x_2) R(x'_1, x'_2)$ and $(x_1, x_2) \neq (x'_1, x'_2)$. Then $x_1 R_1 x'_1$ and $x_2 R_2 x'_2$ and either $x_1 \neq x'_1$ or $x_2 \neq x'_2$. We may suppose that $x_1 \neq x'_1$. Since R_1 is antisymmetric, (x'_1, x_1) is not in R . Thus $(x'_1, x'_2) R(x_1, x_2)$. Therefore, R is antisymmetric.
Transitivity is proved similarly.
40. $\{(1, 1), (2, 2), (3, 3), (4, 4), (1, 2), (2, 3)\}$
41. $\{(1, 1), (2, 2), (3, 3), (4, 4), (1, 2), (2, 3)\}$
43. $\{(1, 2), (2, 3), (1, 3)\}$ 45. True
46. False. Let $R = \{(2, 3), (4, 5)\}$, $S = \{(1, 2), (3, 4)\}$.
48. True 49. True 51. True 52. True
54. False. Let $R = \{(2, 3), (3, 2)\}$, $S = \{(1, 2), (2, 1)\}$.
55. True 57. True
58. False. Let $R = \{(2, 3), (1, 1)\}$, $S = \{(1, 2), (3, 1)\}$.
61. R is reflexive, not symmetric, not antisymmetric, transitive, and not a partial order. To see that R is not symmetric, consider $A = \{1\}$ and $B = \{1, 2\}$. To see that R is not antisymmetric, consider $A =$ all real numbers and $B =$ all rational numbers.
62. R is reflexive, symmetric, not antisymmetric, transitive, and not a partial order. To see that R is not antisymmetric, consider $A =$ all real numbers and $B =$ all rational numbers.
63. It may be the case that for $x \in X$, there is no $y \in X$ such that $(x, y) \in R$. Consider, for example, $X = \{1, 2, 3\}$, $R = \{(1, 1), (2, 2), (1, 2), (2, 1)\}$, and $x = 3$.

Section 3.2

2. Not an equivalence relation (not transitive)
 3. Not an equivalence relation (not reflexive)
 5. Equivalence relation. $[1] = [2] = [3] = [4] = [5] = \{1, 2, 3, 4, 5\}$.
 6. Equivalence relation. $[1] = [5] = \{1, 5\}$, $[2] = \{2\}$, $[3] = \{3\}$, $[4] = \{4\}$.
 8. Not an equivalence relation (not reflexive, not symmetric, not transitive)
 10. Not an equivalence relation (not transitive) 11. Equivalence relation
 13. Equivalence relation 14. Equivalence relation

16. $\{(1, 1), (2, 2), (3, 3), (4, 4), (3, 4), (4, 3)\}$, $[1] = \{1\}$, $[2] = \{2\}$, $[3] = [4] = \{3, 4\}$

17. $\{(1, 1), (2, 2), (3, 3), (4, 4)\}$, $[i] = \{i\}$ for $i = 1, \dots, 4$

19. $\{(i, j) \mid i, j \in \{1, 2, 3, 4\}\}$, $[1] = [2] = [3] = [4] = \{1, 2, 3, 4\}$

20. $\{(1, 1), (2, 2), (2, 4), (4, 2), (4, 4), (3, 3)\}$, $[1] = \{1\}$, $[2] = [4] = \{2, 4\}$, $[3] = \{3\}$

21. Reflexive: ARA since $A \cup Y = A \cup Y$.

Symmetric: If ARB , then $A \cup Y = B \cup Y$. Now $B \cup Y = A \cup Y$, so BRA .

Transitive: Suppose that ARB and BRC . Then $A \cup Y = B \cup Y$ and $B \cup Y = C \cup Y$. Therefore $A \cup Y = C \cup Y$. Thus ARC .

23. Eight. An equivalence class is determined by the presence or absence of 1, 2, and 5.

25. Since R is an equivalence relation, R is reflexive. Therefore $(x, x) \in R$ for all $x \in X$. Therefore

$$\text{domain } R = \text{range } R = X.$$

26. If R is a relation on X having the given property,

$$R = \{(x, y) \mid x \text{ and } y \text{ are in } X\}.$$

28. $\{(1, 1), (2, 2), (3, 3), (4, 4), (5, 5), (6, 6), (1, 2), (2, 1), (3, 4), (4, 3)\}$

29. Five, corresponding to the partitions $\{\{1\}, \{2\}, \{3\}\}$, $\{\{1\}, \{2, 3\}\}$, $\{\{1, 2\}, \{3\}\}$, $\{\{1, 3\}, \{2\}\}$, $\{\{1, 2, 3\}\}$

31. (a) Reflexive: $(a, b)R(a, b)$ for all $a, b \in X$ since $ab = ba$ for all $a, b \in X$.

Symmetric: Suppose that $(a, b)R(c, d)$. Then $ad = bc$. Since $cb = da$, $(c, d)R(a, b)$.

Transitive: Suppose that $(a, b)R(c, d)$ and $(c, d)R(e, f)$. Then $ad = bc$ and $cf = de$. Now $af = adf/d = bcf/d = bde/d = be$. Therefore $(a, b)R(e, f)$.

- (b) $(1, 1), (1, 2), (1, 3), (1, 4), (1, 5), (1, 6), (1, 7), (1, 8), (1, 9), (1, 10), (2, 1), (2, 3), (2, 5), (2, 7), (2, 9), (3, 1), (3, 2), (3, 4), (3, 5), (3, 7), (3, 8), (3, 10), (4, 1), (4, 3), (4, 5), (4, 7), (4, 9), (5, 1), (5, 2), (5, 3), (5, 4), (5, 6), (5, 7), (5, 8), (5, 9), (6, 1), (6, 5), (6, 7), (7, 1), (7, 2), (7, 3), (7, 4), (7, 5), (7, 6), (7, 8), (7, 9), (7, 10), (8, 1), (8, 3), (8, 5), (8, 7), (8, 9), (9, 1), (9, 2), (9, 4), (9, 5), (9, 7), (9, 8), (9, 10), (10, 1), (10, 3), (10, 7), (10, 9)$
- (c) $(a, b)R(c, d)$ if and only if $\frac{a}{b} = \frac{c}{d}$.

32. We show symmetry only. Let $(a, b) \in R \cap R^{-1}$. Then $(a, b) \in R$, so $(b, a) \in R^{-1}$. Since $(a, b) \in R^{-1}$, $(b, a) \in R$. Thus $(b, a) \in R \cap R^{-1}$ and $R \cap R^{-1}$ is symmetric.
34. R is reflexive since for every x , $x \in S$ for some $S \in \mathcal{S}$. R is also symmetric, for suppose that xRy . Then $x, y \in S$ for some $S \in \mathcal{S}$. Thus $y, x \in S$ and yRx . R need not be transitive. Let $X = \{1, 2, 3\}$, $S_1 = \{1, 2\}$, $S_2 = \{2, 3\}$. Then $X = S_1 \cup S_2$. Now $1R2$ and $2R3$, but $1 \not R 3$.
35. (b) Cylinder
37. Reflexive: For every $x \in X$, by the definition of a function $f(x)$ is defined. Since $f(x) = f(x)$, xRx for every $x \in X$.
- Symmetry: Suppose that xRy . Then $f(x) = f(y)$. Since $f(y) = f(x)$, yRx .
- Transitivity: Suppose that xRy and yRz . Then $f(x) = f(y)$ and $f(y) = f(z)$. Therefore $f(x) = f(z)$ and xRz .
38. Suppose that $f = C_Y$. The equivalence classes are Y and \bar{Y} .
40. When x and y are in the same equivalence class
41. Suppose that $[x] = [y]$. Then xRy . Therefore, $g(x) = g(y)$.
44. Since $(y, y) \in \{(x, x) \mid x \in X\}$ for all $y \in X$, $(y, y) \in \rho(R)$ for all $y \in X$. Thus $\rho(R)$ is reflexive.
45. Let (x, y) be in $R \cup R^{-1}$. If (x, y) is in R , (y, x) is in R^{-1} , so (y, x) is in $R \cup R^{-1}$. If (x, y) is in R^{-1} , then (y, x) is in R , so (y, x) is in $R \cup R^{-1}$. In any case, if (x, y) is in $R \cup R^{-1}$, (y, x) is in $R \cup R^{-1}$, so $R \cup R^{-1}$ is symmetric.
47. Since

$$R \subseteq \rho(R), \quad R \subseteq \sigma(R), \quad R \subseteq \tau(R), \quad (3.1)$$

it follows that $R \subseteq \tau(\sigma(\rho(R)))$.

By (3.1), $\rho(R) \subseteq \tau(\sigma(\rho(R)))$ and by Exercise 44, $\rho(R)$ is reflexive. Therefore, $\tau(\sigma(\rho(R)))$ is reflexive.

By Exercise 45, $\sigma(\rho(R))$ is symmetric. We show that if R' is any symmetric relation, $\tau(R')$ is symmetric. We can then conclude that $\tau(\sigma(\rho(R)))$ is symmetric.

Let R' be a symmetric relation. Let $(x, y) \in \tau(R')$. Then there exist $x = x_0, \dots, x_n = y \in X$ such that $(x_{i-1}, x_i) \in R'$ for $i = 1, \dots, n$. Since R' is symmetric, $(x_i, x_{i-1}) \in R'$ for $i = 1, \dots, n$. Thus $(y, x) \in \tau(R')$ and $\tau(R')$ is symmetric.

By Exercise 46, $\tau(\sigma(\rho(R)))$ is transitive; hence $\tau(\sigma(\rho(R)))$ is an equivalence relation containing R .

48. By Exercise 47, $\tau(\sigma(\rho(R)))$ is an equivalence relation containing R .

We first observe that if $R_1 \subseteq R_2 \subseteq X \times X$, then

$$\rho(R_1) \subseteq \rho(R_2), \quad \sigma(R_1) \subseteq \sigma(R_2), \quad \tau(R_1) \subseteq \tau(R_2).$$

It follows that if R' is a relation on X and $R' \supseteq R$,

$$\tau(\sigma(\rho(R'))) \supseteq \tau(\sigma(\rho(R))).$$

The conclusion will follow if we show that if R' is an equivalence relation on X , $R' = \tau(\sigma(\rho(R')))$.

Suppose that R' is an equivalence relation. Since R' is reflexive, $\rho(R') = R'$. Since R' is symmetric, $\sigma(R') = R'$. Thus $\sigma(\rho(R')) = R'$. We show that $\tau(R') = R'$. Clearly, $R' \subseteq \tau(R')$. Let $(x, y) \in \tau(R')$. Then $(x, y) \in R'^n$ for some positive integer n . Thus there exist $x_0, \dots, x_n \in X$ with $x = x_0$, $y = x_n$, and $(x_{i-1}, x_i) \in R'$ for $i = 1, \dots, n$. Since R' is transitive, $(x, y) = (x_0, x_n) \in R'$. Thus $R' \supseteq \tau(R')$. Therefore, $R' = \tau(R')$. Now

$$R' = \tau(R') = \tau(\sigma(\rho(R'))).$$

51. False. Let $R_1 = \{(1, 1), (1, 2)\}$, $R_2 = \{(2, 2), (2, 1)\}$.

52. False. Let $X = \{1, 2, 3\}$, $R_1 = \{(1, 2)\}$, $R_2 = \{(2, 3)\}$.

54. False. Let $R_1 = \{(1, 2), (2, 3)\}$. 55. True

58. X and Y have the same number of elements.

59. The function $f(n) = 2n$ is a one-to-one, onto function from $\{1, 2, \dots\}$ to $\{2, 4, \dots\}$.

Section 3.3

$$2. \begin{pmatrix} 1 & 1 & 0 & 0 \\ 1 & 0 & 1 & 0 \\ 0 & 0 & 0 & 1 \end{pmatrix} \quad 3. \begin{pmatrix} 1 & 0 & 1 & 0 \\ 1 & 1 & 0 & 0 \\ 0 & 0 & 0 & 1 \end{pmatrix} \quad 5. \begin{pmatrix} 0 & 0 & 0 & 0 & 0 \\ 0 & 0 & 0 & 0 & 1 \\ 0 & 0 & 0 & 1 & 0 \\ 0 & 1 & 0 & 0 & 0 \\ 1 & 0 & 0 & 0 & 0 \end{pmatrix}$$

$$6. \begin{pmatrix} 0 & 1 & 1 & 1 \\ 0 & 0 & 1 & 1 \\ 0 & 0 & 0 & 1 \\ 0 & 0 & 0 & 0 \end{pmatrix} \quad 7. \text{ [For Exercise 13]} \begin{pmatrix} 0 & 1 & 1 & 0 \\ 1 & 0 & 0 & 1 \\ 0 & 0 & 1 & 1 \\ 0 & 0 & 0 & 0 \end{pmatrix}$$

$$9. \{(1, 1), (1, 3), (2, 2), (2, 3), (2, 4)\} \quad 10. \{(w, w), (w, y), (y, w), (y, y), (z, z)\}$$

12. Symmetric and transitive 13. Take the transpose of the given matrix.

15. [For Exercise 4] The matrix of R is

$$\begin{pmatrix} 0 & 1 & 0 & 0 & 0 \\ 0 & 0 & 1 & 0 & 0 \\ 0 & 0 & 0 & 1 & 0 \\ 0 & 0 & 0 & 0 & 1 \\ 0 & 0 & 0 & 0 & 0 \end{pmatrix},$$

and its square is

$$\begin{pmatrix} 0 & 0 & 1 & 0 & 0 \\ 0 & 0 & 0 & 1 & 0 \\ 0 & 0 & 0 & 0 & 1 \\ 0 & 0 & 0 & 0 & 0 \\ 0 & 0 & 0 & 0 & 0 \end{pmatrix}.$$

The entry in row 1, column 3 of the square is nonzero, but the entry in row 1, column 3 of the original matrix is zero. Therefore the relation is not transitive.

17. (a) $\begin{pmatrix} 1 & 0 & 1 & 0 \\ 0 & 1 & 0 & 0 \\ 0 & 0 & 1 & 0 \\ 0 & 0 & 0 & 1 \end{pmatrix}$ (b) $\begin{pmatrix} 1 & 0 & 0 & 0 \\ 1 & 1 & 0 & 0 \\ 1 & 1 & 1 & 0 \\ 1 & 1 & 1 & 1 \end{pmatrix}$ (c) $\begin{pmatrix} 2 & 1 & 1 & 0 \\ 1 & 1 & 0 & 0 \\ 1 & 1 & 1 & 0 \\ 1 & 1 & 1 & 1 \end{pmatrix}$

(d) $\begin{pmatrix} 1 & 1 & 1 & 0 \\ 1 & 1 & 0 & 0 \\ 1 & 1 & 1 & 0 \\ 1 & 1 & 1 & 1 \end{pmatrix}$

(e) $\{(2, 1), (2, 2), (2, 3), (3, 1), (3, 2), (4, 1), (4, 2), (4, 3), (5, 1), (5, 2), (5, 3), (5, 4)\}$

18. (a) $\begin{pmatrix} 1 & 1 & 1 & 1 & 1 \\ 1 & 1 & 1 & 1 & 0 \\ 1 & 1 & 1 & 0 & 0 \\ 1 & 1 & 0 & 0 & 0 \\ 1 & 0 & 0 & 0 & 0 \end{pmatrix}$ (b) $\begin{pmatrix} 0 & 0 & 0 & 0 & 0 \\ 1 & 0 & 0 & 0 & 0 \\ 0 & 1 & 0 & 0 & 0 \\ 0 & 0 & 1 & 0 & 0 \\ 0 & 0 & 0 & 1 & 0 \end{pmatrix}$ (c) $\begin{pmatrix} 1 & 1 & 1 & 1 & 0 \\ 1 & 1 & 1 & 0 & 0 \\ 1 & 1 & 0 & 0 & 0 \\ 1 & 0 & 0 & 0 & 0 \\ 0 & 0 & 0 & 0 & 0 \end{pmatrix}$

(d) The matrix of part (c) is the matrix of the relation $R_2 \circ R_1$.

(e) $\{(1, 1), (1, 2), (1, 3), (1, 4), (2, 1), (2, 2), (2, 3), (3, 1), (3, 2), (4, 1)\}$

20. Let a_{ij} denote the ij th entry of A_1 and b_{ij} denote the ij th entry of A_2 . Let n be the number of elements in Y . The ik th entry of A_1A_2 is found by taking the product of the i th row of A_1 and the k th column of A_2 . Thus if c_{ik} is the ik th entry of the product, we have

$$c_{ik} = \sum_{j=1}^n a_{ij}b_{jk}.$$

Now a term in this sum is nonzero only when both factors in the term are nonzero. This will be the case for all j such that $a_{ij} = b_{jk} = 1$. This happens only when $(i, j) \in R_1$ and $(j, k) \in R_2$. c_{ik} is then precisely the number of these j 's.

22. Suppose that the ij th entry of A is 1. Then the ij th entries of both A_1 and A_2 are 1. Thus $(i, j) \in R_1$ and $(i, j) \in R_2$. Therefore $(i, j) \in R_1 \cap R_2$. Now suppose that $(i, j) \in R_1 \cap R_2$. Then the ij th entries of both A_1 and A_2 are 1. Therefore the ij th entry of A is 1. It follows that A is the matrix of $R_1 \cap R_2$.

23. The matrix A of Exercise 21 is

$$\begin{pmatrix} 1 & 1 & 0 \\ 0 & 1 & 1 \\ 1 & 0 & 1 \end{pmatrix},$$

whose relation is

$$R_1 \cup R_2 = \{(1, 1), (1, 2), (2, 2), (2, 3), (3, 1), (3, 3)\}.$$

24. The matrix A of Exercise 22 is

$$\begin{pmatrix} 0 & 0 & 0 \\ 0 & 1 & 0 \\ 1 & 0 & 1 \end{pmatrix},$$

whose relation is

$$R_1 \cap R_2 = \{(2, 2), (3, 1), (3, 3)\}.$$

26. Every column must contain at least one 1.

27. Every column must contain at most one 1.

Section 3.4

2. $\{(23, \text{Jones}), (04, \text{Yu}), (96, \text{Zamora}), (66, \text{Washington})\}$
3. $\{(04, 335B2, 220), (23, 2A, 14), (04, 8C200, 302), (66, 42C, 3), (04, 900, 7720), (96, 20A8, 200), (96, 1199C, 296), (23, 772, 39)\}$
4. $\{(\text{United Supplies}, 2A), (\text{ABC Unlimited}, 8C200), (\text{United Supplies}, 1199C), (\text{JCN Electronics}, 2A), (\text{United Supplies}, 335B2), (\text{ABC Unlimited}, 772), (\text{Danny's}, 900), (\text{United Supplies}, 772), (\text{Underhanded Sales}, 20A8), (\text{Danny's}, 20A8), (\text{DePaul University}, 42C), (\text{ABC Unlimited}, 20A8)\}$
6. DEPARTMENT[Manager]
Jones, Yu, Zamora, Washington
7. SUPPLIER[Part No]
335B2, 2A, 8C200, 42C, 900, 20A8, 1199C, 772
9. TEMP1 := EMPLOYEE[Manager = Jones]
TEMP2 := TEMP1[Name]
Kaminski, Schmidt, Manacotti
10. TEMP := SUPPLIER[Dept = 96]
TEMP[Part No]
20A8, 1199C
12. TEMP1 := DEPARTMENT[Dept = 04]
TEMP2 := TEMP1[TEMP1.Manager = EMPLOYEE.Manager] EMPLOYEE
TEMP3 := TEMP2[Name]
Jones, Beaulieu
13. TEMP := SUPPLIER[Amount \geq 100]
TEMP[Part No]
335B2, 8C200, 900, 20A8, 1199C

15. TEMP1 := BUYER[Name = United Supplies]
 TEMP2 := TEMP1[TEMP1.Part No = SUPPLIER.Part No] SUPPLIER
 TEMP3 := TEMP2[Part No, Amount]

Part No	Amount
335B2	220
2A	14
1199C	296
772	39

16. TEMP1 := BUYER[Name = ABC Unlimited]
 TEMP2 := TEMP1 [Part No = Part No] SUPPLIER
 TEMP3 := TEMP2 [Dept = Dept] DEPARTMENT
 TEMP3[Manager]
 Yu, Jones, Zamora
18. TEMP1 := DEPARTMENT[Manager = Jones]
 TEMP2 := TEMP1[TEMP1.Dept = SUPPLIER.Dept] SUPPLIER
 TEMP3 := TEMP2[TEMP2.Part No = BUYER.Part No] BUYER
 TEMP4 := TEMP3[Name]

United Supplies, JCN Electronics ABC Unlimited

19. TEMP1 := EMPLOYEE[Name = Suzuki]
 TEMP2 := TEMP1 [Manager = Manager] DEPARTMENT
 TEMP3 := TEMP2 [Dept = Dept] SUPPLIER
 TEMP4 := TEMP3 [Part No = Part No] BUYER
 TEMP4[Name]

Underhanded Sales, Danny's, ABC Unlimited, United Supplies

23. The intersection operator will operate on two relations with the same set of attributes (arranged in the same order). The relation resulting from the intersection will have the same set of attributes. A tuple in the new relation will be a tuple in both of the two relations operated on. We will express the intersection operation using the set intersection symbol.

TEMP1 := BUYER[Part No = 2A]
 TEMP2 := TEMP1[Name]
 TEMP3 := BUYER[Part No = 1199C]
 TEMP4 := TEMP3[Name]
 TEMP5 := TEMP2 \cap TEMP4

24. Let R_1 and R_2 be two n -ary relations. The *difference* of R_1 and R_2 is the n -ary relation $R_1 - R_2$.

TEMP1 := EMPLOYEE [Manager = Manager] DEPARTMENT
 TEMP2 := TEMP1[Dept = 04]
 TEMP3 := TEMP1 - TEMP2
 TEMP3[Name]

Suzuki, Kaminski, Ryan, Schmidt, Manacotti

Chapter 4

Solutions to Selected Exercises

Section 4.1

3.

```
min(a, b, c) {
    small = a
    if (b < small)
        small = b
    if (c < small)
        small = c
    return small
}
```

4.

```
second_smallest(a, b, c) {
    x = a
    y = b
    z = c
    if (x > y){
        temp = x
        x = y
        y = temp
    }
    if (y > z) {
        temp = y
        y = z
        z = temp
    }
    if (x > y) {
        temp = x
        x = y
        y = temp
    }
    return y
}
```

```

6. find_large_2nd_large(s, n, large, second_largest) {
    if ( $s_1 < s_2$ ) {
        large =  $s_2$ 
        second_largest =  $s_1$ 
    }
    else {
        large =  $s_1$ 
        second_largest =  $s_2$ 
    }
    for i = 3 to n
        if ( $s_i > \textit{second\_largest}$ )
            if ( $s_i > \textit{large}$ ) {
                second_largest = large
                large =  $s_i$ 
            }
            else
                second_largest =  $s_i$ 
    }
}

7. find_small_2nd_small(s, n, small, second_smallest) {
    if ( $s_1 < s_2$ ) {
        small =  $s_1$ 
        second_smallest =  $s_2$ 
    }
    else {
        small =  $s_2$ 
        second_smallest =  $s_1$ 
    }
    for i = 3 to n
        if ( $s_i < \textit{second\_smallest}$ )
            if ( $s_i < \textit{small}$ ) {
                second_smallest = small
                small =  $s_i$ 
            }
            else
                second_smallest =  $s_i$ 
    }
}

9. find_largest_element(s, n) {
    large =  $s_1$ 
    index_large = 1
    for i = 2 to n
        if ( $s_i > \textit{large}$ ) {
            large =  $s_i$ 
            index_large = i
        }
}

```

- ```

 return index_large
 }

```
10. *find\_last\_largest\_element*(*s*, *n*) {
- ```

  large = s1
  index_large = 1
  for i = 2 to n
    if (si ≥ large) {
      large = si
      index_large = i
    }
  return index_large
}

```
12. *find_out_of_order1*(*s*, *n*) {
- ```

 for i = 2 to n
 if (si < si-1)
 return i
 return 0
}

```
13. *find\_out\_of\_order2*(*s*, *n*) {
- ```

  for i = 2 to n
    if (si > si-1)
      return i
  return 0
}

```
15. Assume that s_n, s_{n-1}, \dots, s_1 and t_n, t_{n-1}, \dots, t_1 are the decimal representations of the two numbers to be added. The output is u_{n+1}, u_n, \dots, u_1 .
- ```

add(s, t, u, n) {
 c = 0
 for i = 1 to n {
 Let xy be the decimal representation of the sum $c + s_i + t_i$.
 ui = y
 c = x
 }
 un+1 = c
}

```
16. *transpose*(*A*, *n*) {
- ```

  for i = 1 to n - 1
    for j = i + 1 to n
      swap(Aij, Aji)
}

```
18. The input is the $n \times n$ matrix *A* of the relation, and *n*.

```

is_symmetric(A, n) {
  for i = 1 to n - 1
    for j = i + 1 to n
      if (Aij ≠ Aji)
        return false
    return true
}

```

19. The input is the $n \times n$ matrix A of the relation, and n .

```

is_transitive(A, n) {
  // first compute B = A2
  for i = 1 to n
    for j = 1 to n {
      Bij = 0
      for k = 1 to n
        Bij = Bij + Aik * Akj
    }
  // if an entry in A2 is nonzero, but the corresponding entry
  // in A is zero, the relation is not transitive
  for i = 1 to n
    for j = 1 to n {
      if (Bij ≠ 0 ∧ Aij == 0)
        return false
    }
  return true
}

```

21. The input is A , the $m \times n$ matrix of the relation, and m and n .

```

is_function(A, m, n) {
  for i = 1 to m {
    sum = 0
    for j = 1 to n
      sum = sum + Aij
    if (sum ≠ 1)
      return false
  }
  return true
}

```

22. The input is the $n \times n$ matrix A of the relation, and n .

```

inverse(A, n) {
  for i = 1 to n - 1
    for j = i + 1 to n
      swap(Aij, Aji)
}

```



```

24. pair_sum(s, n, x) {
    for i = 1 to n - 1
        for j = i + 1 to n
            if (x == si + sj)
                return true
    return false
}

```

Section 4.2

2. First i and j are set to 1. The while loop then compares $t_1t_2t_3 = \text{"bal"}$ with $p = \text{"lai"}$. Since "b" and "l" are not equal, i increments to 2 and j remains 1.

The while loop then compares $t_2t_3t_4 = \text{"ala"}$ with $p = \text{"lai"}$. Since "a" and "l" are not equal, i increments to 3 and j remains 1.

The while loop then compares $t_3t_4t_5 = \text{"lal"}$ with $p = \text{"lai"}$. Since "l" and "l" are equal, j increments. Since "a" and "a" are equal, j increments again. Since "l" and "i" are not equal, i increments to 4 and j is reset to 1.

The while loop then compares $t_4t_5t_6 = \text{"ala"}$ with $p = \text{"lai"}$. Since "a" and "l" are not equal, i increments to 5 and j remains 1.

The while loop then compares $t_5t_6t_7 = \text{"lai"}$ with $p = \text{"lai"}$. Since the comparison succeeds, the algorithm returns $i = 5$ to indicate that p was found in t starting at index 5 in t .

3. First i and j are set to 1. The while loop then compares $t_1t_2t_3 = \text{"000"}$ with $p = \text{"001"}$. Since "0" and "0" are equal, j increments. Since "0" and "0" are equal, j increments again. Since "0" and "1" are not equal, i increments to 2 and j is reset to 1.

The while loop then compares $t_2t_3t_4 = \text{"000"}$ with $p = \text{"001"}$. Since "0" and "0" are equal, j increments. Since "0" and "0" are equal, j increments again. Since "0" and "1" are not equal, i increments to 3 and j is reset to 1.

This pattern repeats until the first for loop terminates. The algorithm then returns 0 to indicate the p was not found in t .

5. First 20 is inserted in

34

Since $20 < 34$, 34 must move one position to the right

	34
--	----

Now 20 is inserted

20	34
----	----

Since $19 < 34$, 34 must move one position to the right

20		34
----	--	----

Since $19 < 20$, 20 must move one position to the right

	20	34
--	----	----

Now 19 is inserted

19	20	34
----	----	----

Since $5 < 34$, 34 must move one position to the right

19	20		34
----	----	--	----

Since $5 < 20$, 20 must move one position to the right

19		20	34
----	--	----	----

Since $5 < 19$, 19 must move one position to the right

	19	20	34
--	----	----	----

Now 5 is inserted

5	19	20	34
---	----	----	----

The sequence is now sorted.

6. Since $55 > 34$, it is immediately inserted to 34's right

34	55
----	----

Since $144 > 55$, it is immediately inserted to 55's right

34	55	144
----	----	-----

Since $259 > 144$, it is immediately inserted to 144's right

34	55	144	259
----	----	-----	-----

The sequence is now sorted.

9. We first swap a_i and a_j , where $i = 1$ and $j = \text{rand}(1, 5) = 2$. After the swap we have

57	34	72	101	135
↑	↑			
i	j			

We next swap a_i and a_j , where $i = 2$ and $j = \text{rand}(2, 5) = 5$. After the swap we have

57	135	72	101	34
	↑			↑
	i			j

We next swap a_i and a_j , where $i = 3$ and $j = \text{rand}(3, 5) = 3$. The sequence is unchanged.

We next swap a_i and a_j , where $i = 4$ and $j = \text{rand}(4, 5) = 4$. The sequence is again unchanged.

10. We first swap a_i and a_j , where $i = 1$ and $j = \text{rand}(1, 5) = 5$. After the swap we have

135	57	72	101	34
↑				↑
i				j

We next swap a_i and a_j , where $i = 2$ and $j = \text{rand}(2, 5) = 5$. After the swap we have

135	34	72	101	57
	↑			↑
	i			j

We next swap a_i and a_j , where $i = 3$ and $j = \text{rand}(3, 5) = 4$. After the swap we have

135	34	101	72	57
		↑	↑	
		i	j	

We next swap a_i and a_j , where $i = 4$ and $j = \text{rand}(4, 5) = 4$. The sequence is unchanged.

12. Use the invariant: s_1, \dots, s_i is sorted.

13. *find_first_key*(s, n, key) {
 for $i = 1$ to n
 if ($\text{key} == s_i$)
 return i
 return 0
 }

```

15. insert(s, n, x) {
    i = 1
    while (i ≤ n ∧ x > si)
        i = i + 1
    // move si, ..., sn down to make room for x
    j = n
    while (j ≥ i) {
        sj+1 = sj
        j = j - 1
    }
    // insert x
    si = x
}

```

16. Replace the line

```
while (ti+j-1 == pj) {
```

by

```
while (j ≤ m ∧ ti+j-1 == pj) {
```

Replace the line

```
return i
```

by

```
println(i)
```

and remove the line

```
return 0
```

18. The worst case occurs when the for loop and the while loop run as long as possible. This situation is achieved when *t* consists of *n* 0's and *p* consists of *m* - 1 0's followed by one 1.

```

19. insertion_sort_nonincreasing(s, n) {
    for i = 2 to n {
        val = si // save si so it can be inserted into the correct place
        j = i - 1
        // if val > sj, move sj right to make room for si
        while (j ≥ 1 ∧ val > sj) {
            sj+1 = sj
            j = j - 1
        }
        sj+1 = val // insert val
    }
}

```

21. [For Exercise 4] Selection sort first finds the smallest item, s_2 , and places it first by swapping s_1 and s_2 . The result is

20	34	144	55
↑	↑		
1	2		

Selection sort next finds the smallest item, s_2 , in s_2, s_3, s_4 , and places it second by swapping s_2 and s_2 . The sequence is unchanged.

Selection sort next finds the smallest item, s_4 , in s_3, s_4 , and places it third by swapping s_3 and s_4 . The result is

20	34	55	144
		↑	↑
		3	4

The sequence is now sorted.

22. In the pseudocode

```

selection_sort(s, n) {
  for i = 1 to n - 1 {
    // find smallest in si, ..., sn
    small_index = i
    for j = i + 1 to n
      if (sj < ssmall_index)
        small_index = j
    swap(si, ssmall_index)
  }
}

```

the for loops always run to completion regardless of the input.

Section 4.3

- | | | | | |
|--------------------------|-------------------------|----------------------|-------------------|-----------------------|
| 2. $\Theta(n^2)$ | 3. $\Theta(n^3)$ | 5. $\Theta(n \lg n)$ | 6. $\Theta(n^6)$ | 8. $\Theta(n^2)$ |
| 9. $\Theta(n \lg n)$ | 11. $\Theta(n)$ | 12. $\Theta(2^n)$ | 14. $\Theta(n^3)$ | 15. $\Theta(n^{5/2})$ |
| 17. $\Theta(n)$ | 18. $\Theta(n^2)$ | 20. $\Theta(n^2)$ | 21. $\Theta(n^3)$ | 23. $\Theta(n^3)$ |
| 24. $\Theta(n)$ | 26. $\Theta(\lg \lg n)$ | 27. $\Theta(n)$ | | |
| 30. (a) Even: $3n/2 - 2$ | Odd: $(3n - 1)/2 - 1$ | (b) $\Theta(n)$ | | |
| 32. Use Example 4.3.6. | | | | |

$$34. 2^n = \underbrace{2 \cdot 2 \cdots 2}_n = 2 \cdot \underbrace{2 \cdot 2 \cdots 2}_{n-1} \leq 2(2 \cdot 3 \cdots n) = 2n!$$

35. First note that

$$\sum_{i=1}^n i \lg i \leq n(n \lg n) = n^2 \lg n.$$

Therefore

$$\sum_{i=1}^n i \lg i = O(n^2 \lg n).$$

Now

$$\sum_{i=1}^n i \lg i \geq \sum_{i=\lceil n/2 \rceil}^n i \lg i \geq \sum_{i=\lceil n/2 \rceil}^n \left\lfloor \frac{n}{2} \right\rfloor \lg \left\lfloor \frac{n}{2} \right\rfloor = \left\lfloor \frac{n+1}{2} \right\rfloor \left\lfloor \frac{n}{2} \right\rfloor \lg \left\lfloor \frac{n}{2} \right\rfloor \geq \left(\frac{n}{2}\right)^2 \lg \left(\frac{n}{2}\right).$$

As in Example 4.3.9, if $n \geq 4$,

$$\left(\frac{n}{2}\right) \lg \left(\frac{n}{2}\right) \geq \frac{n \lg n}{4}.$$

Therefore if $n \geq 4$,

$$\sum_{i=1}^n i \lg i \geq \left(\frac{n}{2}\right)^2 \lg \left(\frac{n}{2}\right) \geq \left(\frac{n}{2}\right) \frac{n \lg n}{4} = \frac{n^2 \lg n}{8}.$$

It follows that

$$\sum_{i=1}^n i \lg i = \Omega(n^2 \lg n).$$

Therefore

$$\sum_{i=1}^n i \lg i = \Theta(n^2 \lg n).$$

37. For sufficiently large n , $n^k \geq \max\{2, c\}$. Therefore, for sufficiently large n ,

$$\lg(n^k + c) \leq \lg(n^k + n^k) = \lg 2n^k \leq \lg n^k n^k = \lg n^{2k} = 2k \lg n.$$

Also, $\lg(n^k + c) \geq \lg n^k = k \lg n$ for all n . Therefore, $\lg(n^k + c) = \Theta(\lg n)$.

$$\begin{aligned} 38. \sum_{i=0}^k \lg(n/2^i) &= (k+1) \lg n - (1 + 2 + \cdots + k) \\ &= (k+1)k - \frac{k(k+1)}{2} \\ &= \frac{(k+1)k}{2} \\ &= \frac{(1 + \lg n) \lg n}{2} = \Theta(\lg^2 n) \end{aligned}$$

40. We show that if $f(n) = \Omega(g(n))$, and $f(n) > 0$ and $g(n) \geq 0$ for all $n \geq 1$, then, for some constant C , $f(n) \geq Cg(n)$ for all $n \geq 1$.

Proof. Since $f(n) = \Omega(g(n))$, $g(n) = O(f(n))$. By Exercise 39, for some constant C' , $g(n) \leq C'f(n)$ for all $n \geq 1$. Taking $C = 1/(1 + C')$, we have $Cg(n) \leq f(n)$ for all $n \geq 1$.

41. Exercises 39 and 40 show that if $f(n) = \Theta(g(n))$, and $f(n) > 0$ and $g(n) > 0$ for all $n \geq 1$, then, for some constants C_1 and C_2 , $C_1g(n) \leq f(n) \leq C_2g(n)$ for all $n \geq 1$.
43. True: $|2 + \sin n| \leq 3 \leq 3|2 + \cos n|$.
45. True
47. False. A counterexample is $f(n) = 1$ for all n , and $g(n) = 1 + 1/n$.
48. False. A counterexample is $f(n) = n$, $g(n) = n^2$. 50. True 51. True
54. If $f(n) \neq O(g(n))$, then for every $C > 0$, $|f(n)| > C|g(n)|$ for infinitely many n . If $g(n) \neq O(f(n))$, then for every $C > 0$, $|g(n)| > C|f(n)|$ for infinitely many n . However, there is no guarantee that even one n for which $|f(n)| > C|g(n)|$ is true also makes $|g(n)| > C|f(n)|$ true.
55. $f(n) = \begin{cases} 1 & \text{if } n \text{ is even} \\ 0 & \text{if } n \text{ is odd,} \end{cases} \quad g(n) = 1 - f(n)$
57. We prove the result by using induction on k .

Basis Step ($k = 1$). By Exercise 17, Section 1.7, $1 + nx \leq (1 + x)^n$, for $x \geq -1$ and $n \geq 1$. Thus, for $x > 0$ and $n \geq 1$, $nx < (1 + x)^n$ or

$$n < \frac{1}{x}(1 + x)^n.$$

Taking $C = 1/x$ and $c = 1 + x$ gives the desired result.

Inductive Step. Assume that if $c > 1$, there exists a constant C such that $n^k \leq Cc^n$ for all but finitely many n . Let $c > 1$. By the inductive assumption, there exists a constant C_1 such that

$$n^k \leq C_1(\sqrt{c})^n$$

for all but finitely many n . By the Basis Step, there exists a constant C_2 such that

$$n \leq C_2(\sqrt{c})^n$$

for all but finitely many n . Multiplying these inequalities, we obtain

$$n^{k+1} = n^k n \leq C_1 C_2 (\sqrt{c})^n (\sqrt{c})^n = C_1 C_2 c^n$$

for all but finitely many n . The Inductive Step is complete. Therefore $n^k = O(c^n)$ for all $k \geq 1$ and $c > 1$.

58. $f(n) = h(n) = t(n) = n$, $g(n) = 2n$
59. The Θ -notation ignores constants that are present in the formula for the *actual* time.
61. Yes
63. By referring to a graph like that of Exercise 62, with $y = 1/x$ replaced by $y = x^m$, we find that

$$1^m + 2^m + \cdots + n^m < \int_1^{n+1} x^m dx = \frac{(n+1)^{m+1} - 1}{m+1} < \frac{(n+1)^{m+1}}{m+1}.$$

The other inequality is proved in a similar manner.

65. We rewrite the inequality of Exercise 64 as

$$b^n[b - (n+1)(b-a)] < a^{n+1}.$$

If we set $a = 1 + 1/(n+1)$ and $b = 1 + 1/n$, the term in brackets reduces to 1 and we have

$$\left(1 + \frac{1}{n}\right)^n < \left(1 + \frac{1}{n+1}\right)^{n+1}.$$

Therefore, the sequence $\{(1 + 1/n)^n\}$ is increasing.

66. We rewrite the inequality of Exercise 64 as

$$b^n[b - (n+1)(b-a)] < a^{n+1}.$$

If we set $a = 1$ and $b = 1 + 1/(2n)$, the term in brackets reduces to $\frac{1}{2}$, and we have

$$\left(1 + \frac{1}{2n}\right)^n < 2.$$

Squaring both sides gives

$$\left(1 + \frac{1}{2n}\right)^{2n} < 4.$$

By Exercise 65, $\{(1 + 1/n)^n\}$ is increasing; thus,

$$\left(1 + \frac{1}{n}\right)^n < \left(1 + \frac{1}{2n}\right)^{2n} < 4.$$

68. Using Exercise 67, we have

$$\sum_{i=1}^n \frac{1}{i} \leq \sum_{i=1}^n [\lg(i+1) - \lg i] = \lg(n+1) \leq \lg 2n = 1 + \lg n \leq 2 \lg n,$$

if $n \geq 2$. Thus,

$$\sum_{i=1}^n \frac{1}{i} = O(\lg n).$$

Again, using Exercise 67, we have

$$\sum_{i=1}^n \frac{1}{i} > \frac{1}{2} \sum_{i=1}^n [\lg(i+1) - \lg i] = \frac{1}{2} \lg(n+1) \geq \frac{1}{2} \lg n.$$

Thus,

$$\sum_{i=1}^n \frac{1}{i} = \Omega(\lg n).$$

Therefore,

$$\sum_{i=1}^n \frac{1}{i} = \Theta(\lg n).$$

69. In the argument given, the constant is dependent on n .

71. False. A counterexample is $f(n) = n$ and $g(n) = n^2$.

72. True. In fact, we can conclude that $f(n) = \Theta(g(n))$ (see the hint to Exercise 73).

74. False. A counterexample is $f(n) = 1$ for all n , and

$$g(n) = \begin{cases} 1, & \text{if } n \text{ is even} \\ 2, & \text{if } n \text{ is odd.} \end{cases}$$

75. False. For a counterexample, see the solution to Exercise 74.

76. **Inductive Step.** Assume that the inequality holds for n . Now

$$\begin{aligned} \lg(n+1)! &= \lg(n+1) + \lg n! \\ &\geq \lg(n+1) + \frac{n}{2} \lg \frac{n}{2}. \end{aligned}$$

If we can show that

$$\lg(n+1) + \frac{n}{2} \lg \frac{n}{2} \geq \frac{n+1}{2} \lg \frac{n+1}{2},$$

the inductive step will be complete.

This last inequality is equivalent, in turn, to

$$\begin{aligned} \lg(n+1) + \frac{n}{2} \lg n - \frac{n}{2} &\geq \frac{n+1}{2} \lg(n+1) - \frac{n+1}{2} \\ \frac{n}{2} \lg n &\geq \frac{n-1}{2} \lg(n+1) - \frac{1}{2} \\ n \lg n &\geq (n-1) \lg(n+1) - 1 \\ n \lg n &\geq n \lg(n+1) - \lg(n+1) - 1 \\ 1 + \lg(n+1) &\geq n[\lg(n+1) - \lg n] \\ 1 + \lg(n+1) &\geq n \left(\lg \frac{n+1}{n} \right) \\ \lg(2(n+1)) &\geq \lg \left(\frac{n+1}{n} \right)^n \\ 2(n+1) &\geq \left(\frac{n+1}{n} \right)^n = \left(1 + \frac{1}{n} \right)^n \end{aligned} \tag{4.1}$$

By Exercise 66,

$$\left(1 + \frac{1}{n} \right)^n < 4,$$

for all n . Thus inequality (4.1) holds for all n .

77. In the following figure,

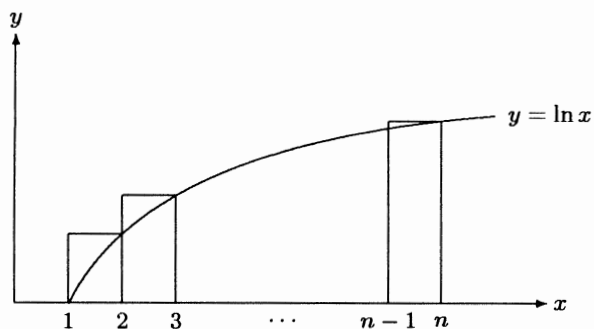

the area of the rectangles exceeds the area under the curve from 1 to n , so

$$\int_1^n \ln x \, dx \leq \sum_{k=1}^n \ln k.$$

Now

$$n \ln n - n < n \ln n - n + 1 = \int_1^n \ln x \, dx.$$

79. The inequality may be rewritten

$$\frac{n}{2}[(\lg n) - 1] \leq \lg n!.$$

Assuming the result of Exercise 78, it suffices to show that

$$\frac{n}{2}[(\lg n) - 1] \leq n \lg n - n \lg e,$$

or, equivalently

$$\frac{1}{2}[(\lg n) - 1] \leq \lg n - \lg e,$$

or, equivalently

$$(\lg e) - \frac{1}{2} \leq \frac{\lg n}{2}. \quad (4.2)$$

Since

$$(\lg e) - \frac{1}{2} = 1.44\dots - 0.5 = 0.9\dots,$$

inequality (4.2) is obviously true for $n \geq 4$. (The given inequality is clearly true for $n = 1, 2, 3$.)

Problem-Solving Corner: Design and Analysis of an Algorithm

- Input: s_1, \dots, s_n
 Output: *max*, maximum sum of consecutive values
begin_ind, starting index of values that give the maximum sum, or 0 if every sum is negative
end_ind, ending index of values that give the maximum sum, or 0 if every sum is negative

```

max_sum4(s, n) {
  max = 0
  sum = 0
  begin_ind = 0
  end_ind = 0
  local_begin_ind = 1
  for i = 1 to n {
    if (sum + si > 0) {
      local_end_ind = i
      sum = sum + si
    }
    else {
      local_begin_ind = i + 1
      sum = 0
    }
    if (sum > max) {
      begin_ind = local_begin_ind
      end_ind = local_end_ind
      max = sum
    }
  }
}

```

Section 4.4

2. Since $n \neq 2$, we proceed to line 6 where we divide the board into four 2×2 boards:

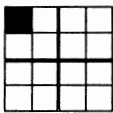

At line 8 we place one right tromino in the center:

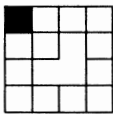

At lines 9 through 12, we recursively tile the 2×2 boards:

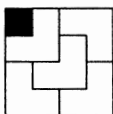

3. Since $n \neq 2$, we proceed to line 6 where we divide the board into four 4×4 boards:

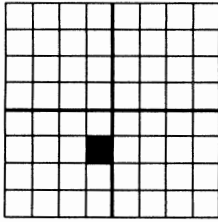

At line 8 we place one right tromino in the center (we do not show the board rotated):

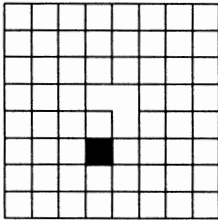

At lines 9 through 12, we recursively tile the 4×4 boards:

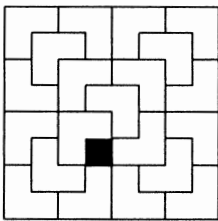

5. Since $n \neq 1$ and $n \neq 2$, we execute the line

$$\text{return } robot_walk(n - 1) + robot_walk(n - 2)$$

with $n = 4$. When we compute $robot_walk(3)$, since $n \neq 1$ and $n \neq 2$, we execute the line

$$\text{return } robot_walk(n - 1) + robot_walk(n - 2)$$

with $n = 3$. The algorithm returns the value 2 for $robot_walk(2)$ and the value 1 for $robot_walk(1)$. Therefore for $n = 3$, the algorithm returns the value

$$robot_walk(2) + robot_walk(1) = 2 + 1 = 3.$$

Therefore for $n = 4$, the algorithm returns the value

$$robot_walk(3) + robot_walk(2) = 3 + 2 = 5.$$

6. Since $n \neq 1$ and $n \neq 2$, we execute the line

$$\text{return } robot_walk(n - 1) + robot_walk(n - 2)$$

with $n = 5$. Exercise 5 shows that the algorithm returns the value 5 for $robot_walk(4)$ and the value 3 for $robot_walk(3)$. Therefore for $n = 5$, the algorithm returns the value

$$robot_walk(4) + robot_walk(3) = 5 + 3 = 8.$$

8. We use induction on n . The Basis Steps, which are readily verified, are $n = 1, 2$. For the Inductive Step, assume that

$$\text{walk}(k) = f_{k+1}$$

for all $k < n$. From the formula in this section, we have

$$\text{walk}(n) = \text{walk}(n-1) + \text{walk}(n-2).$$

By the inductive assumption,

$$\text{walk}(n-1) = f_n \quad \text{and} \quad \text{walk}(n-2) = f_{n-1}.$$

Now

$$\text{walk}(n) = \text{walk}(n-1) + \text{walk}(n-2) = f_n + f_{n-1} = f_{n+1}.$$

9. (a) Input: n
Output: $1 + 2 + \cdots + n$

```
sum(n) {
  if (n == 1)
    return 1
  return n + sum(n-1)
}
```

- (b) **Basis Step** ($n = 1$). If n is equal to 1, we correctly output 1 and stop.

Inductive Step. Assume that the algorithm correctly computes the sum when the input is $n - 1$. Now suppose that the input to this algorithm is $n > 1$. Since $n \neq 1$, we invoke this procedure with input $n - 1$. By the inductive assumption, the value v returned is equal to

$$1 + \cdots + (n-1).$$

We then return

$$v + n = 1 + \cdots + (n-1) + n,$$

which is the correct value.

11. (a) Input: n
Output: The number of ways the robot can walk n meters

```
walk3(n) {
  if (n == 1)
    return 1
  if (n == 2)
    return 2
  if (n == 3)
    return 4
  return walk3(n-1) + walk3(n-2) + walk3(n-3)
}
```

- (b) **Basis Steps** ($n = 1, 2, 3$). If n is equal to 1, 2, or 3, we correctly output the number of ways the robot can walk 1, 2, or 3 meters.

Inductive Step. Assume that the algorithm correctly computes the sum when the input is less than n . The robot's first step is either 1, 2, or 3 meters. If the first step is 1 meter, the robot must finish its walk by walking $n - 1$ meters. By the inductive assumption the robot can complete the walk in $walk3(n - 1)$ ways. Similarly, if the first step is 2 meters, the robot can complete the walk in $walk3(n - 2)$ ways, and if the first step is 3 meters, the robot can complete the walk in $walk3(n - 3)$ ways. Thus the total number of ways the robot can walk n meters is

$$walk3(n - 1) + walk3(n - 2) + walk3(n - 3).$$

Since this is the value computed by the procedure, the algorithm is correct.

12. Input: The sequence s_1, s_2, \dots, s_n and the length n of the sequence
Output: The minimum value in the sequence

```

find_min( $s, n$ ) {
  if ( $n == 1$ )
    return  $s_1$ 
   $x = \text{find\_min}(s, n - 1)$ 
  if ( $x < s_n$ )
    return  $x$ 
  else
    return  $s_n$ 
}

```

We prove that the algorithm is correct using induction on n . The Basis Step is $n = 1$. If $n = 1$, the only item in the sequence is s_1 and the algorithm correctly returns it.

Assume that the algorithm computes the minimum for input of size n , and suppose that the algorithm receives input of size $n + 1$. By assumption, the recursive call

$$x := \text{find_min}(s, n)$$

correctly computes x as the minimum value in the sequence s_1, \dots, s_n . If x is less than s_{n+1} , the minimum value in the sequence s_1, \dots, s_{n+1} is x —the value returned by the algorithm. If x is not less than s_{n+1} , the minimum value in the sequence s_1, \dots, s_{n+1} is s_{n+1} —again, the value returned by the algorithm. In either case, the algorithm correctly computes the minimum value in the sequence. The Inductive Step is complete, and we have proved that the algorithm is correct.

14. Input: The sequence s_i, \dots, s_j , i , and j
Output: The sequence in reverse order

```

reverse( $s, i, j$ ) {
  if ( $i \geq j$ )
    return

```

```

    swap(si, sj)
    reverse(s, i + 1, j - 1)
}

```

15. Input: n
Output: $n!$

```

factorial(n) {
    fact = 1
    for i = 2 to n
        fact = i * fact
    return fact
}

```

17. To list all of the ways that a robot can walk n meters, set s to the null string and invoke this algorithm.

Input: n, s (a string)

Output: All the ways the robot can walk n meters. Each method of walking n meters includes the extra string s in the list.

```

list_walk2(n, s) {
    if (n == 1) {
        println(s + " take one step of length 1")
        return
    }
    if (n == 2) {
        println(s + " take two steps of length 1")
        println(s + " take one step of length 2")
        return
    }
    if (n == 3) {
        println(s + " take three steps of length 1")
        println(s + " take one step of length 1 and one step of length 2")
        println(s + " take one step of length 2 and one step of length 1")
        println(s + " take one step of length 3")
        return
    }
    s' = s + " take one step of length 3" // + is concatenation
    list_walk2(n - 3, s')
    s' = s + " take one step of length 2"
    list_walk2(n - 2, s')
    s' = s + " take one step of length 1"
    list_walk2(n - 1, s')
}

```

19. 233

20. We use strong induction on n . The Basis Steps are $n = 1, 2$. If $n = 1$, there is $1 = f_2$ way to tile a 2×1 board with 1×2 rectangular pieces:



If $n = 2$, there are $2 = f_3$ ways to tile a 2×2 board with 1×2 rectangular pieces:



Now suppose that $n > 2$ and if $k < n$, the number of ways to tile a $2 \times k$ board with 1×2 rectangular pieces is f_{k+1} . Now the first two vertical 1×1 squares can be covered in two ways: using one 1×2 rectangular piece

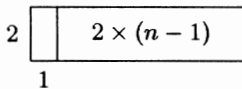

or by using two 1×2 rectangular pieces

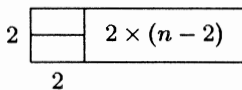

By the inductive assumption, in the first case the remaining $2 \times (n-1)$ board can be tiled in f_n ways, and in the second case, the remaining $2 \times (n-2)$ board can be tiled in f_{n-1} ways. Thus the total number of ways to tile a $2 \times n$ board with 1×2 rectangular pieces is

$$f_n + f_{n-1} = f_{n+1}.$$

The inductive step is complete.

22. $f_{n+2}^2 - f_{n+1}^2 = (f_{n+2} + f_{n+1})(f_{n+2} - f_{n+1}) = f_{n+3}f_n$

23. Using Exercises 21 and 22 and the recurrence relation for the Fibonacci sequence, we have

$$f_{n-2}f_{n+2} = f_{n-2}(f_n + f_{n+1}) = f_n f_{n-2} + f_{n-2}f_{n+1} = f_{n-1}^2 + (-1)^{n+1} + f_n^2 - f_{n-1}^2.$$

The conclusion now follows immediately.

25. **Basis Step** ($n = 2$). $f_4 = 3 = 4 - 1 = f_3^2 - f_1^2$. $f_5 = 5 = 1 + 4 = f_2^2 + f_3^2$.

Inductive Step. Assume true for n . Now

$$\begin{aligned} f_{2n+2} &= f_{2n+1} + f_{2n} \\ &= f_n^2 + f_{n+1}^2 + f_{n+1}^2 - f_{n-1}^2 \\ &= 2f_{n+1}^2 + f_n^2 - f_{n-1}^2 \\ &= 2f_{n+1}^2 + f_n^2 - (f_{n+1} - f_n)^2 \\ &= 2f_{n+1}^2 + f_n^2 - f_{n+1}^2 + 2f_n f_{n+1} - f_n^2 \\ &= f_{n+1}^2 + 2f_n f_{n+1} \\ &= (f_{n+1} + f_n)^2 - f_n^2 \\ &= f_{n+2}^2 - f_n^2. \end{aligned}$$

We now use the just proved formula for f_{2n+2} to prove the formula for f_{2n+3} :

$$f_{2n+3} = f_{2n+2} + f_{2n+1} = f_{n+2}^2 - f_n^2 + f_n^2 + f_{n+1}^2 = f_{n+1}^2 + f_{n+2}^2.$$

The inductive step is complete.

26. **Basis Steps** ($n = 1, 2$). f_1 and f_2 are both odd ($f_1 = f_2 = 1$) and neither 1 nor 2 is divisible by 3. Therefore, the statement is true for $n = 1, 2$.

Inductive Step. Assume that the statement is true for all $k < n$. We must prove that the statement is true for n . We can assume that $n > 2$. We consider two cases: n is divisible by 3 and n is not divisible by 3.

If n is divisible by 3, then neither $n - 1$ nor $n - 2$ is divisible by 3. By the inductive assumption, both f_{n-1} and f_{n-2} are odd. Since $f_n = f_{n-1} + f_{n-2}$, f_n is even. Therefore, if n is divisible by 3, f_n is even.

If n is not divisible by 3, then exactly one of $n - 1$ or $n - 2$ is divisible by 3. By the inductive assumption, one of f_{n-1} and f_{n-2} is odd and the other is even. Since $f_n = f_{n-1} + f_{n-2}$, f_n is odd. Therefore, if n is not divisible by 3, f_n is odd.

We have shown that f_n is even if and only if n is divisible by 3, so the Inductive Step is complete.

28. **Basis Steps** ($n = 1, 2$). $f_1 = 1 \leq 1 = 2^0$; $f_2 = 1 \leq 2 = 2^1$

Inductive Step. Assume that the equation is true for $n - 2$ and $n - 1$. Now

$$f_n = f_{n-1} + f_{n-2} \leq 2^{n-2} + 2^{n-3} < 2^{n-2} + 2^{n-2} = 2^{n-1}.$$

29. **Basis Steps** ($n = 1, 2$). For $n = 1$, we have $f_2 = 1 = 2 - 1 = f_3 - 1$, and $f_1 = 1 = f_2$.

For $n = 2$, we have $f_2 + f_4 = 1 + 3 = 5 - 1 = f_5 - 1$, and $f_1 + f_3 = 1 + 2 = 3 = f_4$.

Inductive Step.

$$\begin{aligned} \sum_{k=1}^{n+1} f_{2k} &= \sum_{k=1}^n f_{2k} + f_{2n+2} \\ &= f_{2n+1} - 1 + f_{2n+2} = f_{2n+3} - 1 \end{aligned}$$

$$\begin{aligned} \sum_{k=1}^{n+1} f_{2k-1} &= \sum_{k=1}^n f_{2k-1} + f_{2n+1} \\ &= f_{2n} + f_{2n+1} = f_{2n+2} \end{aligned}$$

31. We show that the representation

$$n = \sum_{i=1}^m f_{k_i} \tag{4.3}$$

given in the hint for Exercise 30 is unique.

By Exercise 29, the partial sum of Fibonacci numbers with even indexes is

$$\sum_{k=1}^n f_{2k} = f_{2n+1} - 1.$$

If we do not allow f_1 as a summand, the partial sum of Fibonacci numbers with odd indexes becomes

$$\sum_{k=2}^n f_{2k-1} = \sum_{k=1}^n f_{2k-1} - f_1 = f_{2n} - 1,$$

where we have again used Exercise 29.

Suppose by way of contradiction that some integer has a representation as the sum of distinct Fibonacci numbers no two of which are consecutive different from (4.3). Let n denote the smallest such integer. Let

$$n = \sum_{i=1}^j f_{t_i},$$

where $t_1 > t_2 > \dots$, be another representation of n as the sum of distinct Fibonacci numbers no two of which are consecutive.

Since $f_{t_1} \leq n$ and f_{k_1} is the largest Fibonacci number less than or equal to n , $f_{t_1} \leq f_{k_1}$. If $f_{t_1} = f_{k_1}$, $n - f_{k_1}$ has at least two representations as the sum of distinct Fibonacci numbers no two of which are consecutive, which contradicts the minimality of n . Therefore $f_{t_1} < f_{k_1}$. Thus

$$f_{t_1} \leq f_{k_1-1}.$$

In the representation, no two Fibonacci numbers are consecutive, thus

$$f_{t_2} \leq f_{k_1-3}, f_{t_3} \leq f_{k_1-5}, \dots$$

Therefore

$$\begin{aligned} n &= f_{t_1} + f_{t_2} + \dots + f_{t_j} \\ &\leq f_{k_1-1} + f_{k_1-3} + \dots + f_{k_1-(2j-1)} \\ &\leq f_{k_1-1} + f_{k_1-3} + \dots + f_p \quad \text{where } p = 2 \text{ or } 3 \\ &= f_{k_1} - 1 \quad \text{by the preceding comments} \\ &< n, \end{aligned}$$

which is a contradiction. Therefore the representation of an integer as the sum of distinct Fibonacci numbers no two of which are consecutive is unique if we do not allow f_1 as a summand.

32. Exercise 21 shows that

$$f_n^2 = f_{n-1}f_{n+1} + (-1)^{n+1}, \quad n \geq 2,$$

so

$$f_n^2 = f_{n-1}(f_n + f_{n-1}) + (-1)^{n+1}, \quad n \geq 2$$

or

$$f_n^2 - f_{n-1}f_n - f_{n-1}^2 - (-1)^{n+1} = 0, \quad n \geq 2.$$

The quadratic formula gives

$$\begin{aligned} f_n &= \frac{f_{n-1} \pm \sqrt{f_{n-1}^2 - 4[-f_{n-1}^2 - (-1)^{n+1}]}}{2} \\ &= \frac{f_{n-1} \pm \sqrt{5f_{n-1}^2 + 4(-1)^{n+1}}}{2}, \quad n \geq 2. \end{aligned}$$

The negative sign gives an extraneous root since if chosen, we would have, for $n \geq 3$,

$$f_n < \frac{f_{n-1}}{2}$$

or

$$2(f_{n-1} + f_{n-2}) < f_{n-1}$$

or

$$f_{n-1} + 2f_{n-2} < 0$$

which is impossible. The formula for $n = 2$ is correct by inspection.

34. The formula reduces the problem of integrating $\log^n |x|$ to the problem of integrating $\log^{n-1} |x|$, a simpler instance of the original problem. Eventually the problem is reduced to integrating $\log |x|$, which is straightforward.

Another example of a recursive integration formula is

$$\int \sin^{2n} x \, dx = -\frac{\sin^{2n-1} x \cos x}{2n} + \frac{2n-1}{2n} \int \sin^{2n-2} x \, dx.$$

Chapter 5

Solutions to Selected Exercises

Section 5.1

2. Since $\lfloor \sqrt{47} \rfloor = 6$, the for loop in Algorithm 5.1.8 runs from $d = 2$ to 6. For each of these values, $n \bmod d \neq 0$. Therefore the algorithm returns 0 to signal that 47 is prime.
3. Since $\lfloor \sqrt{209} \rfloor = 14$, the for loop in Algorithm 5.1.8 runs from $d = 2$ to 14. For $d = 2$ to 10, $n \bmod d \neq 0$. When $d = 11$, $n \bmod d = 0$. Therefore the algorithm returns 11 to signal that 209 is composite and 11 is a divisor of 209.
5. Since $\lfloor \sqrt{1007} \rfloor = 31$, the for loop in Algorithm 5.1.8 runs from $d = 2$ to 31. For $d = 2$ to 18, $n \bmod d \neq 0$. When $d = 19$, $n \bmod d = 0$. Therefore the algorithm returns 19 to signal that 1007 is composite and 19 is a divisor of 1007.
6. Since $\lfloor \sqrt{4141} \rfloor = 64$, the for loop in Algorithm 5.1.8 runs from $d = 2$ to 64. For $d = 2$ to 40, $n \bmod d \neq 0$. When $d = 41$, $n \bmod d = 0$. Therefore the algorithm returns 41 to signal that 4141 is composite and 41 is a divisor of 4141.
8. Since $\lfloor \sqrt{1050703} \rfloor = 1025$, the for loop in Algorithm 5.1.8 runs from $d = 2$ to 1025. For $d = 2$ to 100, $n \bmod d \neq 0$. When $d = 101$, $n \bmod d = 0$. Therefore the algorithm returns 101 to signal that 1050703 is composite and 101 is a divisor of 1050703.

10. (For Exercise 1) $9 = 3 \cdot 3$

11. $11! = 11 \cdot 10 \cdot 9 \cdot 8 \cdot 7 \cdot 6 \cdot 5 \cdot 4 \cdot 3 \cdot 2$
 $= 11 \cdot (5 \cdot 2) \cdot (3 \cdot 3) \cdot (2 \cdot 2 \cdot 2) \cdot 7 \cdot (3 \cdot 2) \cdot 5 \cdot (2 \cdot 2) \cdot 3 \cdot 2$
 $= 2^8 3^4 5^2 7^1 11^1$

13. 5

14. 30

16. 20

17. 15

19. 331

20. 1

22. 15

23. 7

26. (For Exercise 13) We have $\gcd(5, 25) = 5$ and $\text{lcm}(5, 25) = 25$. Thus

$$\gcd(5, 25) \cdot \text{lcm}(5, 25) = 5 \cdot 25.$$

27. Since $d \mid m$, $m = dq_1$ for some integer q_1 . Since $d \mid n$, $n = dq_2$ for some integer q_2 . Now

$$m - n = dq_1 - dq_2 = d(q_1 - q_2).$$

Therefore, $d \mid (m - n)$.

29. Since $d_1 \mid m$, $m = d_1q_1$ for some integer q_1 . Since $d_2 \mid n$, $n = d_2q_2$ for some integer q_2 . Now

$$mn = (d_1q_1)(d_2q_2) = (d_1d_2)(q_1q_2).$$

Therefore, $d_1d_2 \mid mn$.

30. Since $dc \mid nc$, $nc = dcq$ for some integer q . Since dc is a divisor of nc , $c \neq 0$. Therefore, we may cancel c in $nc = dcq$ to obtain $n = dq$. Therefore, $d \mid n$.

32. After checking whether 2 is a divisor of n , we need not check whether 4, 6, 8, ... divide n . Implementing this change cuts the time by about one-half:

```

is_prime(n) {
    if (n mod 2 == 0)
        return 2
    d = 3
    while (d ≤ ⌊√n⌋) {
        if (n mod d == 0)
            return d
        d = d + 2
    }
    return 0
}

```

Continuing this idea, if we store the primes less than or equal to $\lfloor \sqrt{n} \rfloor$, we need only check whether any of these primes divides n .

33. $2 \cdot 3 \cdot 5 \cdot 7 \cdot 11 \cdot 13 + 1 = 30031 = 509 \cdot 59$

Section 5.2

- | | | | | | |
|--|------------------------------|-------------|----------------|----------------|---------|
| 2. 6 | 3. 7 | 5. 8 | 6. 1001 | 9. 27 | 10. 219 |
| 12. 255 | 13. 3547 | 15. 111101 | 16. 11011111 | 18. 1000000000 | |
| 19. 11000000110100 | 21. 101000 | 22. 1100011 | 24. 1000100010 | | |
| 25. 100010100 | 27. 489 | 28. 15996 | 30. 8349 | 31. 307322 | |
| 33. (For Exercise 14) 22 | 34. (For Exercise 26) 111010 | | | | |
| 36. 903 | 37. 565D | 39. 130FF7 | | | |
| 41. 1101010 represents a number in binary, decimal, and hexadecimal. | | | | | |

43. 4003 44. 4041 46. 519 47. 179889
 49. (For Exercise 14) 42 50. (For Exercise 26) 72 52. Yes
 53. 30470 does not represent a number in binary, but it does represent a number in octal, decimal, and hexadecimal.
 55. Suppose that the base b representation of m is

$$m = \sum_{i=0}^k c_i b^i,$$

$c_k \neq 0$. Then

$$b^k \leq c_k b^k \leq m,$$

and

$$m \leq \sum_{i=0}^k (b-1)b^i = (b-1) \sum_{i=0}^k b^i = (b-1) \frac{b^{k+1} - 1}{b-1} = b^{k+1} - 1 < b^{k+1}.$$

Since $b^k \leq m$, taking logs to the base b , we obtain

$$k \leq \log_b m.$$

Since $m < b^{k+1}$, again taking logs, we obtain

$$\log_b m < k + 1.$$

Combining these inequalities, we have

$$k + 1 \leq 1 + \log_b m < k + 2.$$

Therefore, the number of digits required to represent m is

$$k + 1 = \lceil 1 + \log_b m \rceil.$$

57. The algorithm begins by setting *result* to 1 and x to a . Since $n = 15 > 0$, the body of the while loop executes. Since $n \bmod 2$ is equal to 1, *result* becomes *result* * $x = 1 * a = a$. x becomes a^2 , and n becomes 7.

Since $n = 7 > 0$, the body of the while loop executes. Since $n \bmod 2$ is equal to 1, *result* becomes *result* * $x = a * a^2 = a^3$. x becomes a^4 , and n becomes 3.

Since $n = 3 > 0$, the body of the while loop executes. Since $n \bmod 2$ is equal to 1, *result* becomes *result* * $x = a^3 * a^4 = a^7$. x becomes a^8 , and n becomes 1.

Since $n = 1 > 0$, the body of the while loop executes. Since $n \bmod 2$ is equal to 1, *result* becomes *result* * $x = a^7 * a^8 = a^{15}$. x becomes a^{16} , and n becomes 0.

Since $n = 0$ is not greater than 0, the while loop terminates. The algorithm returns *result*, which is equal to a^{15} .

58. The algorithm begins by setting *result* to 1 and *x* to *a*. Since $n = 80 > 0$, the body of the while loop executes. Since $n \bmod 2$ is not equal to 1, *result* is not modified. *x* becomes a^2 , and *n* becomes 40.

Since $n = 40 > 0$, the body of the while loop executes. Since $n \bmod 2$ is not equal to 1, *result* is not modified. *x* becomes a^4 , and *n* becomes 20.

Since $n = 20 > 0$, the body of the while loop executes. Since $n \bmod 2$ is not equal to 1, *result* is not modified. *x* becomes a^8 , and *n* becomes 10.

Since $n = 10 > 0$, the body of the while loop executes. Since $n \bmod 2$ is not equal to 1, *result* is not modified. *x* becomes a^{16} , and *n* becomes 5.

Since $n = 5 > 0$, the body of the while loop executes. Since $n \bmod 2$ is equal to 1, *result* becomes $result * x = 1 * a^{16} = a^{16}$. *x* becomes a^{32} , and *n* becomes 2.

Since $n = 2 > 0$, the body of the while loop executes. Since $n \bmod 2$ is not equal to 1, *result* is not modified. *x* becomes a^{64} , and *n* becomes 1.

Since $n = 1 > 0$, the body of the while loop executes. Since $n \bmod 2$ is equal to 1, *result* becomes $result * x = a^{16} * a^{64} = a^{80}$. *x* becomes a^{128} , and *n* becomes 0.

Since $n = 0$ is not greater than 0, the while loop terminates. The algorithm returns *result*, which is equal to a^{80} .

60. The algorithm begins by setting *result* to 1 and *x* to $a \bmod z = 143 \bmod 230 = 143$. Since $n = 10 > 0$, the body of the while loop executes. Since $n \bmod 2$ is not equal to 1, *result* is not modified. *x* is set to $(x * x) \bmod z = (143 * 143) \bmod 230 = 20449 \bmod 230 = 209$, and *n* is set to 5.

Since $n = 5 > 0$, the body of the while loop executes. Since $n \bmod 2$ is equal to 1, *result* is set to $(result * x) \bmod z = 209 \bmod 230 = 209$. *x* is set to $(x * x) \bmod z = (209 * 209) \bmod 230 = 43681 \bmod 230 = 211$, and *n* is set to 2.

Since $n = 2 > 0$, the body of the while loop executes. Since $n \bmod 2$ is not equal to 1, *result* is not modified. *x* is set to $(x * x) \bmod z = (211 * 211) \bmod 230 = 44521 \bmod 230 = 131$, and *n* is set to 1.

Since $n = 1 > 0$, the body of the while loop executes. Since $n \bmod 2$ is equal to 1, *result* is set to $(result * x) \bmod z = (209 * 131) \bmod 230 = 27379 \bmod 230 = 9$. *x* is set to $(x * x) \bmod z = (131 * 131) \bmod 230 = 17161 \bmod 230 = 141$, and *n* is set to 0.

Since $n = 0$ is not greater than 0, the while loop terminates. The algorithm returns *result*, which is equal to $a^n \bmod z = 143^{10} \bmod 230 = 9$.

61. The algorithm begins by setting *result* to 1 and *x* to $a \bmod z = 143 \bmod 230 = 143$. Since $n = 100 > 0$, the body of the while loop executes. Since $n \bmod 2$ is not equal to 1, *result* is not modified. *x* is set to $(x * x) \bmod z = (143 * 143) \bmod 230 = 20449 \bmod 230 = 209$, and *n* is set to 50.

Since $n = 50 > 0$, the body of the while loop executes. Since $n \bmod 2$ is not equal to 1, *result* is not modified. *x* is set to $(x * x) \bmod z = (209 * 209) \bmod 230 = 43681 \bmod 230 = 211$, and *n* is set to 25.

Since $n = 25 > 0$, the body of the while loop executes. Since $n \bmod 2$ is equal to 1, *result* is set to $(\text{result} * x) \bmod z = 211 \bmod 230 = 211$. x is set to $(x * x) \bmod z = (211 * 211) \bmod 230 = 44521 \bmod 230 = 131$, and n is set to 12.

Since $n = 12 > 0$, the body of the while loop executes. Since $n \bmod 2$ is not equal to 1, *result* is not modified. x is set to $(x * x) \bmod z = (131 * 131) \bmod 230 = 17161 \bmod 230 = 141$, and n is set to 6.

Since $n = 6 > 0$, the body of the while loop executes. Since $n \bmod 2$ is not equal to 1, *result* is not modified. x is set to $(x * x) \bmod z = (141 * 141) \bmod 230 = 19881 \bmod 230 = 101$, and n is set to 3.

Since $n = 3 > 0$, the body of the while loop executes. Since $n \bmod 2$ is equal to 1, *result* is set to $(\text{result} * x) \bmod z = (211 * 101) \bmod 230 = 21311 \bmod 230 = 151$. x is set to $(x * x) \bmod z = (101 * 101) \bmod 230 = 10201 \bmod 230 = 81$, and n is set to 1.

Since $n = 1 > 0$, the body of the while loop executes. Since $n \bmod 2$ is equal to 1, *result* is set to $(\text{result} * x) \bmod z = (151 * 81) \bmod 230 = 12231 \bmod 230 = 41$. x is set to $(x * x) \bmod z = (81 * 81) \bmod 230 = 6561 \bmod 230 = 121$, and n is set to 0.

Since $n = 0$ is not greater than 0, the while loop terminates. The algorithm returns *result*, which is equal to $a^n \bmod z = 143^{100} \bmod 230 = 41$.

63. **Basis Step** ($n = 1$). Since $T_{n!} = 0$ and $S_n = 1$, the result holds for $n = 1$.

Inductive Step. Assume true for n . Now

$$T_{(n+1)!} = T_{(n+1)n!} = T_{n+1} + T_{n!} = T_{n+1} + n - S_n,$$

where we have used the result of Exercise 62 and the inductive assumption. Thus the inductive step will be complete if we can show that $T_{n+1} = 1 + S_n - S_{n+1}$.

Suppose that n is even. Then $n+1$ is odd, so $T_{n+1} = 0$. Now $n = \dots 0$ in binary, so $n+1 = \dots 1$. Therefore $S_{n+1} = 1 + S_n$. Thus $T_{n+1} = 1 + S_n - S_{n+1}$, if n is even.

Suppose that n is odd, say,

$$n = \dots 0 \underbrace{11 \dots 11}_{k \text{ 1's}}.$$

Then

$$n + 1 = \dots 1 \underbrace{00 \dots 00}_{k \text{ 0's}}.$$

Thus $S_n - S_{n+1} = k - 1$ and $T_{n+1} = k$. Therefore $T_{n+1} = 1 + S_n - S_{n+1}$, if n is odd.

64. Input: b, m, b', n

Output: *prod*, the binary product of b and b'

$\text{add}(p + q, i, r)$ computes the sum of the binary numbers p and q , except that q is shifted i places left (effectively appending i zeros on the right), with the result in r .

```

binary_product(b, m, b', n) {
  prod = 0
  for i = 1 to n
    if (b'_i == 1)
      add(prod + b, i, prod)
  return prod
}

```

65. The for loop runs in time $O(n)$. Adding $prod$ and b takes time m (the appended zeros are *not* added). Thus the time is $O(mn)$. Since m and n are the number of bits to represent the numbers that are multiplied, the result follows.

Section 5.3

2. 1 3. 20 5. 20 6. 331 8. 495 9. 23 12. 89, 55

13. Suppose that lines 3 and 4 in Algorithm 5.3.3 are deleted. If $a \geq b$, clearly the result is the same as in the original form. If $a < b$, then $b \neq 0$ and the first iteration of the while loop swaps a and b . Thereafter, the algorithm proceeds as in the original form, and again the result is the same.

15. Let m be a common divisor of a and b . By Theorem 5.1.3(a), m divides $a + b$. Thus m is a common divisor of a and $a + b$.

Let m be a common divisor of a and $a + b$. By Theorem 5.1.3(b), m divides $(a + b) - a = b$. Thus m is a common divisor of a and b .

Since the set of common divisors of a and $a + b$ is equal to the set of common divisors of a and b , $\gcd(a, b) = \gcd(a, a + b)$.

16. Let m be a common divisor of a and b . By Theorem 5.1.3(b), m divides $a - b$. Thus m is a common divisor of b and $a - b$.

Let m be a common divisor of b and $a - b$. By Theorem 5.1.3(a), m divides $(a - b) + b = a$. Thus m is a common divisor of a and b .

Since the set of common divisors of b and $a - b$ is equal to the set of common divisors of a and b , $\gcd(a, b) = \gcd(a - b, b)$.

18. The algorithm given in the hint in the book to Exercise 17 does m subtractions in the worst case, which occurs when $a = m$ and $b = 1$.

19.

a	b	0	1	2	3	4	5	6	7	8	9	10	11	12	13	14	15	16	17	18	19	20	21
0	–	0	0	0	0	0	0	0	0	0	0	0	0	0	0	0	0	0	0	0	0	0	0
1	0	1	1	1	1	1	1	1	1	1	1	1	1	1	1	1	1	1	1	1	1	1	1
2	0	1	1	2	1	2	1	2	1	2	1	2	1	2	1	2	1	2	1	2	1	2	1
3	0	1	2	1	2	3	1	2	3	1	2	3	1	2	3	1	2	3	1	2	3	1	2
4	0	1	1	2	1	2	2	3	1	2	2	3	1	2	2	3	1	2	2	3	1	2	2
5	0	1	2	3	2	1	2	3	4	3	1	2	3	4	3	1	2	3	4	3	1	2	3
6	0	1	1	1	2	2	1	2	2	2	3	3	1	2	2	2	3	3	1	2	2	2	2
7	0	1	2	2	3	3	2	1	2	3	3	4	4	3	1	2	3	3	4	4	3	1	2
8	0	1	1	3	1	4	2	2	1	2	2	4	2	5	3	3	1	2	2	4	2	5	5
9	0	1	2	1	2	3	2	3	2	1	2	3	2	3	4	3	4	3	1	2	3	2	2
10	0	1	1	2	2	1	3	3	2	2	1	2	2	3	3	2	4	4	3	3	1	2	2
11	0	1	2	3	3	2	3	4	4	3	2	1	2	3	4	4	3	4	5	5	4	3	3
12	0	1	1	1	1	3	1	4	2	2	2	2	1	2	2	2	2	4	2	5	3	3	3
13	0	1	2	2	2	4	2	3	5	3	3	3	2	1	2	3	3	3	5	3	4	6	6
14	0	1	1	3	2	3	2	1	3	4	3	4	2	2	1	2	2	4	3	4	3	2	2
15	0	1	2	1	3	1	2	2	3	3	2	4	2	3	2	1	2	3	2	4	2	3	3
16	0	1	1	2	1	2	3	3	1	4	4	3	2	3	2	2	1	2	2	3	2	3	3
17	0	1	2	3	2	3	3	3	2	3	4	4	4	3	4	3	2	1	2	3	4	3	3
18	0	1	1	1	2	4	1	4	2	1	3	5	2	5	3	2	2	2	1	2	2	2	2
19	0	1	2	2	3	3	2	4	4	2	3	5	5	3	4	4	3	3	2	1	2	3	3
20	0	1	1	3	1	1	2	3	2	3	1	4	3	4	3	2	2	4	2	2	1	2	2
21	0	1	2	1	2	2	2	1	5	2	2	3	3	6	2	3	3	3	2	3	2	1	1

a	b	n (= number of modulus operations)
1	0	0
2	1	1
3	2	2
5	3	3
8	5	4
13	8	5
21	13	6

21. Using induction on n , we prove that when the pair f_{n+2}, f_{n+1} is input to the Euclidean algorithm, exactly n modulus operations are required.

Basis Step ($n = 1$). Table 5.3.2 shows that when the pair f_3, f_2 is input to the Euclidean algorithm, one modulus operation is required.

Inductive Step. Assume that when the pair f_{n+2}, f_{n+1} is input to the Euclidean algorithm, n modulus operations are required. We must show that when the pair f_{n+3}, f_{n+2} is input to the Euclidean algorithm, $n + 1$ modulus operations are required.

At line 6, since

$$f_{n+3} = f_{n+2} + f_{n+1},$$

$r = f_{n+1}$. The algorithm then repeats using the values of f_{n+2} and f_{n+1} . By the inductive assumption, exactly n additional modulus operations are required. Thus a total of $n + 1$ modulus operations are required.

22. We prove this result by induction on $\max(a, b)$. We omit the Basis Step.

Without loss of generality, we assume that $a \geq b$. If $b = 0$, zero modulus operations are required to compute $\gcd(a, b)$ and $\gcd(ka, kb)$. Suppose that $b > 0$. Suppose that when we divide a by b , we obtain

$$a = bq + r, \quad 0 \leq r < b.$$

Multiplying these last inequalities by k , we obtain

$$ka = (kb)q + kr, \quad 0 \leq kr < kb.$$

Thus when we divide ka by kb , we obtain the remainder kr . In computing $\gcd(a, b)$, we continue by computing $\gcd(b, r)$. In computing $\gcd(ka, kb)$, we continue by computing $\gcd(kb, kr)$. By the inductive assumption, these computations require the same number of modulus operations. Thus the number of modulus operations required to compute $\gcd(a, b)$ is the same as the number of modulus operations required to compute $\gcd(ka, kb)$. The Inductive Step is complete.

24. If p divides a , we are done; so suppose that p does not divide a . We must show that p divides b . Since p is prime, $\gcd(p, a) = 1$. By Theorem 5.3.7, there are integers s and t such that

$$1 = sp + ta.$$

Multiplying both sides of this equation by b , we obtain

$$b = spb + tab.$$

By Theorem 5.1.3(c), p divides spb and p divides tab . By Theorem 5.1.3(a), p divides $spb + tab = b$.

25. $p = 4, a = 6, b = 10$

28. X has a least element by the Well-Ordering Property.

29. Let $g = sa + tb$. If $c \mid a$ and $c \mid b$, then $c \mid sa + tb = g$.

31. Exercise 30 shows that g is a common divisor. Exercise 29 shows that g is the greatest common divisor.

33. $s = 1$ 34. $s = 3$ 36. $s = 134$ 37. $s = 67$

40. The subsection *Computing an Inverse Modulo an Integer* shows that if $\gcd(n, \phi) = 1$, then n has an inverse modulo ϕ .

Now suppose that n has an inverse s modulo ϕ . Then

$$ns \bmod \phi = 1.$$

Since 1 is the remainder, there exists q such that

$$ns = \phi q + 1.$$

Now suppose that c is a positive common divisor of n and ϕ . Then c divides ns and ϕq and also

$$ns - \phi q = 1.$$

Therefore $c = 1$ and $\gcd(n, \phi) = 1$.

Problem-Solving Corner: Making Postage

1. Let $k = \gcd(p, q)$. Suppose that we can make m cents postage using a p -cent and b q -cent stamps. Then $ap + bq = m$. Then $k \mid m$. Since $k > 1$, $k \nmid m + 1$. Therefore we cannot make $m + 1$ cents postage. The conclusion follows.

Section 5.4

2. DRINK YOUR OVALTINE

3. WEISERKYEIEFTKK_□

5. $c = a^n \bmod z = 333^{29} \bmod 713 = 306$

6. $a = c^s \bmod z = 411^{569} \bmod 713 = 500$

8. $\phi = (p - 1)(q - 1) = 16 \cdot 22 = 352$

9. $s = 159$

11. $a = c^s \bmod z = 250^{159} \bmod 391 = 10$

13. $\phi = (p - 1)(q - 1) = 58 \cdot 100 = 5800$

14. $s = 3961$

16. $a = c^s \bmod z = 250^{3961} \bmod 5959 = 5648$

Chapter 6

Solutions to Selected Exercises

Section 6.1

2. $2 \cdot 3 \cdot 5$ 3. $3 \cdot 3 \cdot 5$ 5. $5 \cdot 6 \cdot 2 \cdot 3 \cdot 3$ 6. $2^6 - 1$

7. Since there are three kinds of cabs, two kinds of cargo beds, and five kinds of engines, the correct number of ways to personalize the big pickups is $3 \cdot 2 \cdot 5 = 30$ —not 32.

9. 3 10. 6 12. 6 13. 10 15. $5 \cdot 5$ 16. $2 \cdot 3^2$ 18. 50^2

19. $50 \cdot 49$ 21. 2^4 22. 2^6 24. 8 25. $(8 \cdot 7)/2$ 27. 2^4

29. $4 \cdot 3 \cdot 2$ 30. $3 \cdot 2 \cdot 4$ 32. $5 \cdot 4 + 5 \cdot 4 \cdot 3$ 33. $2 \cdot 5 \cdot 4$ 35. $5 \cdot 4 \cdot 3$

36. 5^2 38. 4^3 39. $4 \cdot 3 \cdot 2$ 41. $3 \cdot 4 \cdot 3$ 43. $(200 - 4)/2$

44. $(200 - 4)/2$ 46. $200 - 72$ 47. $5 + 9 \cdot 9 + 9 \cdot 8$ 49. $196 - (9 + 2 + 18)$

50. $1 + 1 \cdot 9 \cdot 9 - 2$ 52. $2 + 3 + \dots + 9 = 44$

53. (a) $12 \cdot 11 \cdot 10 \cdot 9 \cdot 8$ (b) 12^5 (c) $12^5 - 12 \cdot 11 \cdot 10 \cdot 9 \cdot 8$

55. $(5!)(2!)(3!)$ 56. $(5!)(5!)$ 58. $8! \cdot 9 \cdot 8$

59. $26 + 26 \cdot 36 + 26 \cdot 36^2 + 26 \cdot 36^3 + 26 \cdot 36^4 + 26 \cdot 36^5$ 60. m^n 62. $2 \cdot 3 \cdot 3 \cdot 2$

63. A subset X has n elements or less if and only if \bar{X} has more than n elements. Thus exactly half of the subsets have n elements or less. Therefore, the number of subsets is $\frac{1}{2}2^{2n+1} = 2^{2n}$.

67. $2^8 - 2^6$

68. Let

X = selections in which Ben is chairperson
 Y = selections in which Alice is secretary

By Exercise 65,

$$|X \cup Y| = |X| + |Y| - |X \cap Y|.$$

By previous methods, we find that

$$|X| = |Y| = 5 \cdot 4, \quad |X \cap Y| = 4.$$

Therefore

$$|X \cup Y| = 20 + 20 - 4 = 36.$$

70. $6 + 18 - 3 = 21$

71. n^{n^2}

72. $n^{n(n-1)/2}$

Section 6.2

2. $abcd, abdc, acbd, acdb, adbc, adcb,$
 $bacd, badc, bcad, bcda, bdac, bdca,$
 $cabd, cadb, cbad, cbda, cdab, cdba,$
 $dabc, dacb, dbac, dbca, dcab, dcba$

3. $P(4, 3) = 4(3)(2) = 24$

5. $11!$

6. $P(11, 5) = 11 \cdot 10 \cdot 9 \cdot 8 \cdot 7$

8. $P(12, 4) = 12 \cdot 11 \cdot 10 \cdot 9$

9. $P(12, 3) = 12 \cdot 11 \cdot 10$

11. $3! \cdot 3!$

12. Tokens labeled AE , C , and DB can be permuted in $3!$ ways.

14. $\frac{1}{2}5!$ since half have A before D and half have A after D .

15. We first count the number of strings containing either AB or CD . To this end, let

X = strings that contain AB

Y = strings that contain CD

By Exercise 65, Section 6.1,

$$|X \cup Y| = |X| + |Y| - |X \cap Y|.$$

By previous methods, we find that

$$|X| = |Y| = 4!, \quad |X \cap Y| = 3!.$$

Therefore there are $4! + 4! - 3!$ strings that contain either AB or CD . Since there are $5!$ total strings, the number that contain neither AB nor CD is $5! - (4! + 4! - 3!)$.

17. $C(5, 3) \cdot 2!$. Pick three slots for A , C , and E . Then place the two remaining letters.

18. Let

X = strings that contain DB

Y = strings that contain BE

By Exercise 65, Section 6.1,

$$|X \cup Y| = |X| + |Y| - |X \cap Y|.$$

By previous methods, we find that

$$|X| = |Y| = 4!, \quad |X \cap Y| = 3!.$$

Therefore

$$|X \cup Y| = 4! + 4! - 3!.$$

20. First, line up the Vesuvians and the Jovians. This can be done in $18!$ ways. For each of these arrangements, we can place the Martians in 5 of the 19 in-between and end positions, which can be done in $P(19, 5)$ ways. Thus there are $18! \cdot P(19, 5)$ arrangements.

22. $9!$

23. Seat the Martians ($4!$ ways). Seat the Jovians in the in-between spots ($5 \cdot 4 \cdot 3 \cdot 2 \cdot 1$ ways). The answer is $4! \cdot 5!$.

26. $\{a, b, c\}, \{a, b, d\}, \{a, c, d\}, \{b, c, d\}$

27.

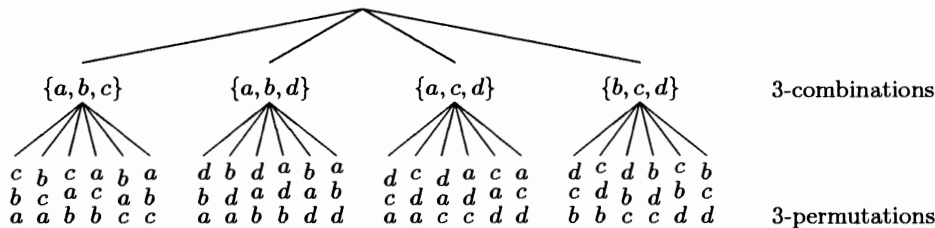

29. $C(12, 4)$

30. $C(44, 6), C(48, 6)$

32. $C(13, 7)$

33. $C(13, 4) - C(6, 4)$ [The number of possible committees is $C(13, 4)$. The number that have no women is $C(6, 4)$.]

35. $C(13, 4) - [C(6, 4) + C(7, 4)]$ (The total number of minus the number with all men or all women.)

36. $C(13, 4) - C(11, 2)$ [The number of possible committees is $C(13, 4)$. The number in which Mabel and Ralph serve together is $C(11, 2)$.]

38. $C(8, 3)$

39. Six: 00011111, 10001111, 11000111, 11100011, 11110001, 11111000

42. $13 \cdot C(48, 1)$ (Choose the denomination and then the odd card.)

43. $C(13, 5)$

45. $4 \cdot C(13, 2) \cdot 13^3$ (You must pick two of one suit and one of each of the three remaining suits. First choose the suit to have two cards. Then choose two cards. Then choose one of each of the remaining suits.)

46. 4

48. $9 \cdot 4^5$ (Pick the lowest card's denomination. Then pick the suit of each of the denominations.)

49. $C(13, 2)C(11, 1)C(4, 2)C(4, 2)C(4, 1)$ (Pick the two denominations that receive two cards; pick the denomination to receive one card; pick two cards from each of the chosen denominations; pick one card from the other denomination.)
51. 4
52. $C(4, 2)[C(26, 13) - 2]$ [Pick the two suits. The number of hands containing cards from the chosen suits is $C(26, 13)$. Subtract the two hands that contain only cards of one of the chosen suits.]
54. $C(13, 5)C(13, 4)C(13, 3)C(13, 1)$
55. $4!C(13, 5)C(13, 4)C(13, 3)C(13, 1)$ [Pick the suits (the order determines which gets 5, 4, 3, 1). Then pick the desired number of cards from the selected suits.]
57. $C(32, 13)$ (Select 13 cards from among the 32 non-face cards.)
59. $C(10, 3)$ 60. $C(10, 3) + C(10, 2) + C(10, 1) + C(10, 0)$
62. $C(10, 5)$ 64. $C(46, 4)$
65. $C(46, 2)C(4, 2)$ (Select 2 good and 2 defective.)
67. Represent each of the two 10's by a star ("*"). The remaining $n - 4$ bits can be placed in the three in-between and end positions with respect to the two stars. For each of these three groups of bits, if a 1 occurs, the bits to its right in that group must also be 1's. We place a vertical bar "|" in between the 0's and 1's in each of these groups. Each string can be represented by $0^a|1^b*0^c|1^d*0^e|1^f$, where $0 \leq a, b, c, d, e, f \leq n - 4$ and $a + b + c + d + e + f = n - 4$. Note that the length of the string is $n + 1$. A particular string is determined by the choice of five slots from $n + 1$ slots for the pattern $|*|*|$. Hence there are $C(n + 1, 5)$ such strings.
68. Fix $n - k$ 1's. The k 0's must be assigned to the $n - k + 1$ positions between the 1's or at either end. This can be done in $C(n - k + 1, k)$ ways.
69. Look at the formula for $C(n, k)$.
72. Argue as in Example 6.2.23.
73. Note that the minimum number of votes for Wright is $\lceil n/2 \rceil$. Thus, By Exercise 72, the number of ways the votes could be counted is

$$1 + \sum_{r=\lceil n/2 \rceil}^{n-1} [C(n, r) - C(n, r + 1)] = C(n, \lceil n/2 \rceil).$$

(The first term, 1, is the number of ways Wright receives n votes and Upshaw receives 0 votes.)

75. By Exercise 73, k vertical steps can occur in $C(k, \lceil k/2 \rceil)$ ways, since, at any point, the number of up steps is greater than or equal to the number of down steps. Then, $n - k$ horizontal steps can be inserted among the k vertical steps in $C(n, k)$ ways. These $n - k$ horizontal steps can occur in $C(n - k, \lceil (n - k)/2 \rceil)$ ways, since, at any point, the number of right steps is greater

than or equal to the number of left steps. Thus, the number of paths that stay in the first quadrant containing exactly k vertical steps is

$$C(k, \lceil k/2 \rceil)C(n, k)C(n - k, \lceil (n - k)/2 \rceil).$$

Summing over all k , we find that the total number of paths is

$$\sum_{k=0}^n C(k, \lceil k/2 \rceil)C(n, k)C(n - k, \lceil (n - k)/2 \rceil).$$

76. Fix a starting position, and move around the table. When a handshake begins, write R ; when a handshake ends, write a U . The result is a sequence of n R 's and n U 's in which the number of R 's is always greater than or equal to the number of U 's. Furthermore, the correspondence between such sequences and handshakes is one-to-one and onto. Since the number of sequences of n R 's and n U 's in which the number of R 's is always greater than or equal to the number of U 's is C_n (see Example 6.2.23), the number of ways that $2n$ persons seated around a circular table can shake hands in pairs without any arms crossing is also C_n .

77. We show a one-to-one, onto correspondence between the output i_1, i_2, \dots, i_n reversed and sequences of n R 's and n U 's in which the number of R 's is always greater than or equal to the number of U 's. Since the number of such sequences is C_n , the result then follows.

For each sequence of n R 's and n U 's in which the number of R 's is always greater than or equal to the number of U 's, under each R write the number of D 's that precede it. For example, for $n = 3$ we would have

R	R	D	R	D	D
0	0		1		

Then add one to each value of the resulting sequence. In our case, we obtain the sequence 112. For $n = 3$, the complete correspondence is

<i>RD Sequence</i>	<i>Numeric Sequence</i>	<i>Numeric Sequence Reversed (Output)</i>
<i>RRRDDD</i>	111	111
<i>RRDRDD</i>	112	211
<i>RRDDRD</i>	113	311
<i>RDRRDD</i>	122	221
<i>RDRDRD</i>	123	321

78. There are $P(n, r)$ ways to place the r distinct objects. There is one way to place the identical objects in the remaining slots. Thus the total number of orderings is $P(n, r)$.

There are $C(n, n - r) = C(n, r)$ ways to choose positions for the $n - r$ identical objects. After placing the identical objects in these positions, there are $r!$ ways to place the distinct objects. Thus the number of total orderings is $r!C(n, r)$. Therefore

$$P(n, r) = r!C(n, r).$$

79. The Addition Principle must be applied to a family of pairwise disjoint sets. Here the sets involved are *not* pairwise disjoint. For example, if X is the set of hands containing clubs, diamonds, and spades and Y is the set of hands containing clubs, diamonds, and hearts, $X \cap Y$ contains hands that contain clubs and diamonds.
81. (a) If there are more tables than people, it is impossible to seat at least one person at each table.
- (b) If there are equal numbers of tables and people and there is at least one person at each table, there will be exactly one person at each table.
- (c) See Example 6.2.7.
- (d) In this case, there are two people at one table and one person at each other table. The two people to sit at one table can be chosen in $C(n, 2)$ ways.
- (e) We prove this equation by induction on n . The Basis Step, $n = 2$, is part (b). Assume that the equation is true for n and that we have $n + 1$ people. Choose one person. Either this person sits alone or with others. If the person sits alone, the other persons can be seated at the other table in $(n - 1)!$ ways. If this person is not alone, by the inductive hypothesis the remaining n persons can be seated in

$$(n - 1)! \sum_{i=1}^{n-1} \frac{1}{i}$$

ways. The $(n + 1)$ st person can be added to this seating arrangement in n ways (to the right of any of the other n persons). Thus there are

$$n \cdot (n - 1)! \sum_{i=1}^{n-1} \frac{1}{i} = n! \sum_{i=1}^{n-1} \frac{1}{i}$$

ways to seat $n + 1$ people if the $(n + 1)$ st person does not sit alone. Therefore the total number of seatings is

$$(n - 1)! + n! \sum_{i=1}^{n-1} \frac{1}{i} = n! \sum_{i=1}^n \frac{1}{i}.$$

The Inductive Step is complete.

- (f) Fix n . Each seating of n persons at k round tables, with at least one person at each table, determines a unique permutation of $1, \dots, n$. If $p(i, 1), \dots, p(i, e_i)$ are seated clockwise at table i , $i = 1, \dots, k$, in this order, we interpret this as the permutation defined by the mapping

$$\begin{aligned} p(1, 1) &\rightarrow p(1, 2) \\ p(1, 2) &\rightarrow p(1, 3) \\ &\vdots \\ p(1, e_1 - 1) &\rightarrow p(1, e_1) \\ p(1, e_1) &\rightarrow p(1, 1) \\ &\vdots \end{aligned}$$

$$\begin{aligned}
 p(k, 1) &\rightarrow p(k, 2) \\
 p(k, 2) &\rightarrow p(k, 3) \\
 &\vdots \\
 p(k, e_k - 1) &\rightarrow p(k, e_k) \\
 p(k, e_k) &\rightarrow p(k, 1)
 \end{aligned}$$

(This representation is called the *decomposition of a permutation into its cycles*.) Since all permutations are accounted for, the equation follows.

(g) We show that $s_{3,1} = 2$ and

$$s_{n,n-2} = 2C(n, n-3) + 3C(n, n-4)$$

for $n \geq 4$.

$s_{3,1} = 2$ by part (c).

If $n \geq 4$, there are two basic seating arrangements:

1. $n - 3$ tables of one person each and one table of three persons. There are $2C(n, n - 3)$ such seatings since we may select the $n - 3$ solitary persons in $C(n, n - 3)$ ways, and then seat the remaining three persons at one table in $2!$ ways (using the formula from part (c)).
 2. $n - 4$ tables of one person each and two tables of two persons each. Select the $n - 4$ solitary persons in $C(n, n - 4)$ ways, and then seat the remaining four persons in three ways. In this case, there are $3C(n, n - 4)$ seatings.
82. (a) If $k > n$, an n -element set cannot be partitioned into k nonempty subsets.
- (b) There is one way to partition an n -element set into n nonempty subsets: Each subset must consist of one element.
- (c) There is one way to partition an n -element set into one nonempty subset: The subset is the n -element set itself.
- (d)–(f) See (g) and (h).
- (g) Let X be an n -element set and let $x \in X$. For each nonempty subset Y of $X - \{x\}$, $\{Y, X - Y\}$ is a partition of X . Since these are also all the partitions, $S_{n,2} = 2^{n-1} - 1$.
- (h) A partition of an n -element set into $n - 1$ subsets consists of a subset containing two elements and $n - 2$ subsets each containing one element. The 2-element subset can be chosen in $C(n, 2)$ ways. Therefore $S_{n,n-1} = C(n, 2)$.
- (i) $S_{n,n-2} = C(n, 3) + 3C(n, 4)$.

If we partition an n -element set into $n - 2$ subsets, either there is a subset consisting of three elements with all other subsets consisting of one element [there are $C(n, 3)$ of these], or there are two subsets each consisting of two elements with all other subsets consisting of one element [there are $C(n, 4)$ ways to choose the elements to be the doubletons and three ways to organize the four elements into doubletons].

Problem-Solving Corner: Combinations

1. From the following figure, we derive the formula

$$\sum_{k=0}^m C(k+p, p)C(m-k+n-p, n-p) = C(m+n, m)$$

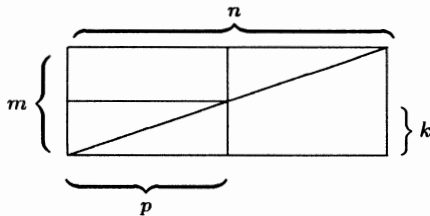

2. $\sum_{k=0}^{\min\{m,n\}} C(m, k)C(n, k) = C(m+n, m)$

Section 6.3

2. 12456 3. 23456 5. 631245 6. 13245678
8. (For Exercise 5) After the while loop in lines 7–9 finishes, m is 2. After the while loop in lines 11–13 finishes, k is 5. At line 14, we swap s_2 and s_5 . Now the sequence is 635421. The while loop of lines 17–22 reverses s_3, \dots, s_6 . The result is 631245.
10. 12, 13, 14, 15, 16, 23, 24, 25, 26, 34, 35, 36, 45, 46, 56
11. 12345, 12346, 12347, 12356, 12357, 12367, 12456, 12457, 12467, 12567, 13456, 13457, 13467, 13567, 14567, 23456, 23457, 23467, 23567, 24567, 34567
13. 123, 132, 213, 231, 312, 321
15. Change line 5 to
- ```

while (true) {
 Add the following lines after line 13 to the body of the while loop at lines 11–13
 if ($k == 0$)
 return
 (Also, since there will now be multiple lines in the body of the while loop, enclose them in braces.)
}

```
16. Input:  $r, n$   
Output: A list of all  $r$ -permutations of  $\{1, 2, \dots, n\}$

```

list_r_perms(r, n) {
 for $i = 1$ to r
 $s_i = i$
 r_comb(r)
}

```

```

for $i = 2$ to $C(n, r)$ {
 find the rightmost s_m not at its maximum value
 $s_m = s_m + 1$
 for $j = m + 1$ to r
 $s_j = s_j + 1$
 $r_comb(r)$
}
}

```

```

 $r_comb(r)$ {
 for $i = 1$ to r
 $t_i = s_i$
 $println(t)$
 for $i = 2$ to $r!$ {
 find the largest index m satisfying $t_m < t_{m+1}$
 find the largest index k satisfying $t_k > t_m$
 $swap(t_m, t_k)$
 reverse the order of the elements t_{m+1}, \dots, t_r
 $println(t)$
 }
}

```

18. Input:  $s_1, \dots, s_n$  (a permutation of  $\{1, \dots, n\}$ ) and  $n$   
 Output:  $s_1, \dots, s_n$ , the next permutation. (The first permutation follows the last permutation.)

```

 $next_perm(s, n)$ {
 $s_0 = 0$ // dummy value
 $m = n - 1$
 while ($s_m > s_{m+1}$)
 $m = m - 1$
 $k = n$
 while ($s_m > s_k$)
 $k = k - 1$
 if ($m > 0$)
 $swap(s_m, s_k)$
 $p = m + 1$
 $q = n$
 while ($p < q$) {
 $swap(s_p, s_q)$
 $p = p + 1$
 $q = q - 1$
 }
}

```

20. Input:  $s_1, \dots, s_n$  (a permutation of  $\{1, \dots, n\}$ ) and  $n$   
 Output:  $s_1, \dots, s_n$ , the previous permutation. (The last permutation precedes the first permutation.)

```

prev_perm(s, n) {
 s0 = n + 1 // dummy value
 // working from right, find first index where si > si+1
 i = n - 1
 while (si < si+1)
 i = i - 1
 // reverse si+1, ..., sn
 j = i + 1
 k = n
 while (j < k) {
 swap(sj, sk)
 j = j + 1
 k = k - 1
 }
 // if i > 0, swap si with the first s value after si that is less than si
 if (i > 0) {
 j = i + 1
 while (sj > si)
 j = j + 1
 swap(si, sj)
 }
}

```

22. Input:  $s_1, \dots, s_n, n$ , and a string  $\alpha$   
 Output: All permutations of  $s_1, \dots, s_n$ , each prefixed by  $\alpha$ . (To list all permutations of  $s_1, \dots, s_n$ , invoke this procedure with  $\alpha$  equal to the null string.)

```

perm_rekurs(s, n, α) {
 if (n == 1) {
 println(α + s1)
 return
 }
 for i = 1 to n {
 α' = α + si
 perm_rekurs({s1, ..., si-1, si+1, ..., sn}, n - 1, α')
 }
}

```

## Section 6.4

2. (H,2), (H,4), (H,6)                      3. (H,1), (H,3), (H,5), (T,1), (T,3), (T,5)



6. (1,1), (2,2), (3,3), (4,4), (5,5), (6,6)
7. (1,4), (2,4), (3,4), (4,4), (5,4), (6,4), (4,1), (4,2), (4,3), (4,5), (4,6)
9. Suppose that the experiment is: Roll three dice. An event is: The sum of the dice is 8.
10. Suppose that the experiment is: Roll three dice. The sample space is the set of all possible outcomes. (There are 216 possible outcomes.)
12.  $\frac{3}{6}$       13.  $\frac{5}{6}$       15.  $\frac{4}{52}$       16.  $\frac{13}{52}$
18. Since an odd sum can be obtained in 18 ways,

$$(1,2), (1,4), (1,6), (2,1), (2,3), (2,5), (3,2), (3,4), (3,6), \\ (4,1), (4,3), (4,5), (5,2), (5,4), (5,6), (6,1), (6,3), (6,5),$$

the probability of obtaining an odd sum is  $\frac{18}{36}$ .

19. Since doubles can be obtained in six ways, (1,1), (2,2), (3,3), (4,4), (5,5), (6,6), the probability of obtaining doubles is  $\frac{6}{36}$ .
21. Exactly one defective microprocessor can be obtained in  $10 \cdot C(90, 3)$  ways. (Choose one defective microprocessor and choose three good microprocessors.) Since four microprocessors can be chosen in  $C(100, 4)$  ways, the probability of obtaining exactly one defective microprocessor is

$$\frac{10 \cdot C(90, 3)}{C(100, 4)}.$$

22. At most one defective microprocessor can be obtained in  $C(90, 4) + 10 \cdot C(90, 3)$  ways. (Choose four good microprocessors, or choose one defective microprocessor and three good microprocessors.) Since four microprocessors can be chosen in  $C(100, 4)$  ways, the probability of obtaining at most one defective microprocessor is

$$\frac{C(90, 4) + 10 \cdot C(90, 3)}{C(100, 4)}.$$

24.  $\frac{3!}{10^3}$       25.  $\frac{1}{C(49, 6)}$       27.  $\frac{1}{C(31, 7)}$       29.  $\frac{C(26, 13)}{C(52, 13)}$       31.  $\frac{1}{2^{10}}$
32.  $\frac{10}{2^{10}}$       35.  $1 - \frac{1}{3^{10}}$       36.  $\frac{1}{3^{10}}$

39. An equivalent problem is to count strings of three  $C$ 's and nine  $N$ 's in which no two  $C$ 's are consecutive since we can regard the positions of the  $C$ 's as representing the chosen lockers. For example, the string  $NNCNNCNNNNC$  represents the choice of lockers 3, 7, and 12, no two of which are consecutive. We can obtain such strings by placing the three  $C$ 's in the 10 in-between positions of the nine  $N$ 's:

$$\_ N \_ N \_ N \_ N \_ N \_ N \_ N \_ N \_ N \_$$

The number of ways of choosing the positions for the  $C$ 's is, thus,  $C(10, 3)$ . Therefore the probability that no two lockers are consecutive is

$$\frac{C(10, 3)}{C(12, 3)}.$$

40.  $1 - \frac{C(10, 3)}{C(12, 3)}$

42.  $\left(\frac{18}{38}\right)^2$

43.  $\frac{1}{38}$

46. If you make a random decision, you are choosing randomly between two doors—one with a goat and one with the car; therefore, the probability of winning the car is  $\frac{1}{2}$ .
47. Suppose that behind the first two doors are goats, and behind the third door is the car. Consider your three initial choices. If you initially choose door one, your switch will move you to the door with the car, and you win. Similarly, if you initially choose door two, your switch will move you to the door with the car, and you win. However, if you initially choose door three, your switch will move you to a door with a goat, and you lose. Therefore the probability of winning the car is  $\frac{2}{3}$ .
49. If you make a random decision, you are choosing randomly between three doors—two with goats and one with the car; therefore, the probability of winning the car is  $\frac{1}{3}$ .
50. Suppose that behind the first three doors are goats, and behind the fourth door is the car. There are eight equally probable outcomes. If you initially choose door one, you switch to either a door with a goat or a door with a car. Similarly, if you initially choose door two or three, you switch to either a door with a goat or a door with a car. If you initially choose door four, you switch to one of two doors, each of which hides a goat. Of the eight possibilities, three win a car. Therefore the probability of winning the car is  $\frac{3}{8}$ .

52. The reasoning is not correct. As a small example, suppose that the sample space consist of eight eggs:

$$g_1, g_2, g_3, g_4, g_5, g_6, b_1, b_2,$$

where  $g_i$  denotes a good egg and  $b_i$  denotes a bad egg. Then the probability of a bad egg is  $1/4$ . However, the set  $\{g_1, g_2, g_3, g_4\}$  of four eggs contains no bad eggs.

53. The probability that the player who chooses HT wins is  $3/4$ . There are four ways that the sequence of tosses can start: TT, HT, TH, HH. If the sequence starts TT, the player who chooses TT wins. If the sequence starts HT, the player who chooses HT wins. However, the player who chooses HT wins in the other two cases as well. To show this we argue by contradiction. Suppose that the player who chooses TT wins. Consider the first appearance of TT. Because the sequence begins TH or HH, the first T (in TT) must be preceded by H. Therefore HT wins. Contradiction.

## Section 6.5

2. Since

$$P(2) = P(4) = P(6) = \frac{1}{8},$$

the probability of getting an even number is

$$P(2) + P(4) + P(6) = \frac{3}{8}.$$

3. Since the probability of getting a 5 is  $\frac{1}{8}$ , the probability of not getting a 5 is  $1 - \frac{1}{8} = \frac{7}{8}$ .

5.  $\frac{1}{4}$           6.  $\frac{1}{4}$

9. The sum of 7 is obtained in six ways: (1,6), (2,5), (3,4), (4,3), (5,2), (6,1). Now

$$P(1, 6) = P(1)P(6) = \frac{1}{4} \cdot \frac{1}{12} = \frac{1}{48}.$$

Similarly,

$$P(2, 5) = P(3, 4) = P(4, 3) = P(5, 2) = P(6, 1) = \frac{1}{48}.$$

Therefore the probability of the sum of 7 is

$$6 \left( \frac{1}{48} \right) = \frac{1}{8}.$$

10. Doubles or a sum of 6 is obtained in 10 ways: (1,5), (2,4), (3,3), (4,2), (5,1), (1,1), (2,2), (4,4), (5,5), (6,6). Now

$$P(1, 5) = P(1)P(5) = \left( \frac{1}{4} \right)^2 = \frac{1}{16}.$$

Similarly,

$$P(3, 3) = P(5, 1) = P(1, 1) = P(5, 5) = \frac{1}{16},$$

$$P(2, 4) = P(4, 2) = P(2, 2) = P(4, 4) = P(6, 6) = \frac{1}{144}.$$

Therefore the probability of getting doubles or the sum of 6 is

$$5 \left( \frac{1}{16} + \frac{1}{144} \right).$$

12. Let  $E_1$  be the event “sum of 6,” let  $E_2$  be the event “doubles,” and let  $E_3$  be the event “at least one 2.” We want

$$P(E_1 \cup E_2 | E_3) = \frac{P((E_1 \cup E_2) \cap E_3)}{P(E_3)}.$$

The event  $(E_1 \cup E_2) \cap E_3$  comprises (2,4), (4,2), (2,2); therefore,

$$P((E_1 \cup E_2) \cap E_3) = 3 \left( \frac{1}{12} \right)^2.$$

The solution to Exercise 11 shows that

$$P(E_3) = \frac{23}{144}.$$

Therefore

$$P(E_1 \cup E_2 | E_3) = \frac{P((E_1 \cup E_2) \cap E_3)}{P(E_3)} = \frac{\frac{3}{144}}{\frac{23}{144}} = \frac{3}{23}.$$

13. Let  $E_1$  be the event “sum of 6,” let  $E_2$  be the event “sum of 8,” and let  $E_3$  be the event “at least one 2.” We want

$$P(E_1 \cup E_2 | E_3) = \frac{P((E_1 \cup E_2) \cap E_3)}{P(E_3)}.$$

The event  $(E_1 \cup E_2) \cap E_3$  comprises (2,4), (4,2), (2,6), (6,2); therefore,

$$P((E_1 \cup E_2) \cap E_3) = 4 \left( \frac{1}{12} \right)^2.$$

The solution to Exercise 11 shows that

$$P(E_3) = \frac{23}{144}.$$

Therefore

$$P(E_1 \cup E_2 | E_3) = \frac{P((E_1 \cup E_2) \cap E_3)}{P(E_3)} = \frac{\frac{4}{144}}{\frac{23}{144}} = \frac{4}{23}.$$

15. (H,3)      16. No      18. No      20.  $1 - \frac{C(90,10)}{C(100,10)}$
21.  $\frac{C(10,3)C(90,3) + C(10,4)C(90,2) + C(10,5)C(90,1) + C(10,6)}{C(100,10)}$

23.  $\frac{C(4,2)}{2^4}$

24. The probability of all boys or all girls is  $\frac{2}{2^4}$ , so the probability of at least one boy and at least one girl is

$$1 - \frac{2}{2^4}.$$

26. Let  $E$  be the event “exactly two girls,” and let  $F$  be the event “at least one girl.” We want to compute

$$P(E | F) = \frac{P(E \cap F)}{P(F)}.$$

Now

$$P(E \cap F) = P(E) = \frac{C(4,2)}{2^4},$$

and

$$P(F) = 1 - P(\text{no girls}) = 1 - \frac{1}{2^4}.$$

Therefore

$$P(E | F) = \frac{P(E \cap F)}{P(F)} = \frac{\frac{C(4,2)}{2^4}}{1 - \frac{1}{2^4}}.$$

27. Let  $E$  be the event “at least one boy,” and let  $F$  be the event “at least one girl.” We want to compute

$$P(E \cap F | F) = \frac{P((E \cap F) \cap F)}{P(F)} = \frac{P(E \cap F)}{P(F)}.$$

Now

$$P(E \cap F) = 1 - \frac{2}{2^4},$$

and

$$P(F) = 1 - \frac{1}{2^4}.$$

Therefore

$$P(E \cap F | F) = \frac{P(E \cap F)}{P(F)} = \frac{1 - \frac{2}{2^4}}{1 - \frac{1}{2^4}}.$$

29. Let  $E$  be the event “at most one boy,” and let  $F$  be the event “at most one girl.” Then  $P(E) = P(F) = 1 - \frac{5}{2^4}$ , and  $P(E \cap F) = 0$ . Since

$$P(E \cap F) = 0 \neq \left(1 - \frac{5}{2^4}\right)^2 = P(E)P(F),$$

$E$  and  $F$  are not independent.

30. Let  $E$  be the event “children of both sexes,” and let  $F$  be the event “at most one girl.” Then

$$P(E) = 1 - \frac{2}{2^n}, \quad P(F) = \frac{n+1}{2^n}, \quad P(E \cap F) = P(\text{exactly one girl}) = \frac{n}{2^n}.$$

Now  $E$  and  $F$  are independent if and only if

$$P(E \cap F) = P(E)P(F),$$

or

$$\frac{n}{2^n} = \left(1 - \frac{1}{2^{n-1}}\right) \left(\frac{n+1}{2^n}\right).$$

This equation simplifies to  $2^{n-1} = n + 1$ , whose only solution is  $n = 3$ . (By inspection,  $2^{n-1} \neq n + 1$  if  $n = 1, 2$ . For  $n > 3$ ,  $2^{n-1} > n + 1$ .) Therefore  $E$  and  $F$  are independent if and only if  $n = 3$ .

$$32. \frac{C(10, 5)}{2^{10}} \quad 33. \frac{C(10, 4) + C(10, 5) + C(10, 6)}{2^{10}}$$

$$35. \frac{C(10, 0) + C(10, 1) + C(10, 2) + C(10, 3) + C(10, 4) + C(10, 5)}{2^{10}}$$

36. Let  $E$  be the event “exactly five heads,” and let  $F$  be the event “at least one head.” We want to compute

$$P(E | F) = \frac{P(E \cap F)}{P(F)}.$$

Now

$$P(E \cap F) = P(E) = \frac{C(10, 5)}{2^{10}},$$

and

$$P(F) = 1 - P(\text{no heads}) = 1 - \frac{1}{2^{10}}.$$

Therefore

$$P(E | F) = \frac{P(E \cap F)}{P(F)} = \frac{\frac{C(10, 5)}{2^{10}}}{1 - \frac{1}{2^{10}}}.$$

38. Let  $E$  be the event “at least one head,” and let  $F$  be the event “at least one tail.” We want to compute

$$P(E|F) = \frac{P(E \cap F)}{P(F)}.$$

Now

$$P(E \cap F) = 1 - P(\text{all heads or all tails}) = 1 - \frac{2}{2^{10}},$$

and

$$P(F) = 1 - P(\text{no tails}) = 1 - \frac{1}{2^{10}}.$$

Therefore

$$P(E|F) = \frac{P(E \cap F)}{P(F)} = \frac{1 - \frac{2}{2^{10}}}{1 - \frac{1}{2^{10}}}.$$

39. Let  $E$  be the event “at most five heads,” and let  $F$  be the event “at least one head.” We want to compute

$$P(E|F) = \frac{P(E \cap F)}{P(F)}.$$

Now

$$\begin{aligned} P(E \cap F) &= P(1 \text{ or } 2 \text{ or } 3 \text{ or } 4 \text{ or } 5 \text{ heads}) \\ &= \frac{C(10,1) + C(10,2) + C(10,3) + C(10,4) + C(10,5)}{2^{10}}, \end{aligned}$$

and

$$P(F) = 1 - P(\text{no heads}) = 1 - \frac{1}{2^{10}}.$$

Therefore

$$P(E|F) = \frac{P(E \cap F)}{P(F)} = \frac{\frac{C(10,1)+C(10,2)+C(10,3)+C(10,4)+C(10,5)}{2^{10}}}{1 - \frac{1}{2^{10}}}.$$

41. Let  $H$  be the event “has headache,” and let  $F$  be the event “has fever.” We are given

$$P(H) = 0.01, \quad P(F|H) = 0.4, \quad P(F) = 0.02.$$

Using Bayes' Theorem, we have

$$P(H|F) = \frac{P(F|H)P(H)}{P(F)} = \frac{(0.4)(0.01)}{0.02} = 0.2.$$

43.  $P(B|A) = 0.01$ ,  $P(B|D) = 0.03$ ,  $P(B|N) = 0.03$

44.

$$\begin{aligned} P(A|B) &= \frac{P(B|A)P(A)}{P(B|A)P(A) + P(B|D)P(D) + P(B|N)P(N)} \\ &= \frac{(0.01)(0.55)}{(0.01)(0.55) + (0.03)(0.1) + (0.03)(0.35)} = 0.289473684. \end{aligned}$$

Similarly,

$$P(D|B) = 0.157894736, \quad P(N|B) = 0.552631578.$$

47. By Theorem 6.5.9,

$$P(E_1 \cap E_2) = P(E_1) + P(E_2) - P(E_1 \cup E_2).$$

Since

$$P(E_1 \cup E_2) \leq 1,$$

the result follows.

48. The Basis Step is  $P(E_1) \leq P(E_1)$ , which is clearly true.

Assume the statement is true for  $n$ . By Theorem 6.5.9,

$$\begin{aligned} P(E_1 \cup E_2 \cup \cdots \cup E_n \cup E_{n+1}) &= P(E_1 \cup E_2 \cup \cdots \cup E_n) + P(E_{n+1}) \\ &\quad - P((E_1 \cup E_2 \cup \cdots \cup E_n) \cap E_{n+1}). \end{aligned}$$

Since

$$P((E_1 \cup E_2 \cup \cdots \cup E_n) \cap E_{n+1}) \geq 0,$$

we have

$$P(E_1 \cup E_2 \cup \cdots \cup E_n \cup E_{n+1}) \leq P(E_1 \cup E_2 \cup \cdots \cup E_n) + P(E_{n+1}).$$

Using the inductive assumption, we have

$$\begin{aligned} P(E_1 \cup E_2 \cup \cdots \cup E_n \cup E_{n+1}) &\leq P(E_1 \cup E_2 \cup \cdots \cup E_n) + P(E_{n+1}) \\ &\leq \sum_{i=1}^n P(E_i) + P(E_{n+1}) = \sum_{i=1}^{n+1} P(E_i). \end{aligned}$$

50. Yes. Since  $E$  and  $F$  are independent,  $P(E \cap F) = P(E)P(F)$ . Since  $E \cap F$  and  $E \cap \bar{F}$  are mutually exclusive and  $E = (E \cap F) \cup (E \cap \bar{F})$ ,

$$P(E) = P(E \cap F) + P(E \cap \bar{F}).$$

Now

$$P(E \cap \bar{F}) = P(E) - P(E \cap F) = P(E) - P(E)P(F) = P(E)[1 - P(F)] = P(E)P(\bar{F}).$$

Therefore  $E$  and  $\bar{F}$  are independent.

51. No. If the person carries a bomb on the plane the probability of a bomb on the plane is 1. The probability of two bombs on the plane is then  $1 \cdot 0.000001 = 0.000001$ .

## Section 6.6

2.  $6!/2!$       3.  $12!/(4!2!)$

5. We form strings in which no two  $S$ 's are consecutive by first placing the letters *ALEPERON*, which can be done in

$$\frac{8!}{2!}$$

ways. We then place the four  $S$ 's in the nine in-between positions

— A — L — E — P — E — R — O — N —,

which can be done in  $C(9, 4)$  ways. Thus

$$\frac{C(9, 4)8!}{2!}$$

strings can be formed by ordering the letters *SALESPERSONS* if no two *S*'s are consecutive.

6. We count the number of strings of length zero, the number of strings of length one, and so on, and then sum these numbers. The number of strings of length zero is one, and the number of strings of length one is five.

There is one string of length two that uses the two *O*'s, and there are  $5 \cdot 4$  strings of length two that do not use two *O*'s (formed by selecting a 2-permutation of *SCHOL*). Thus there are 21 strings of length two.

There are four ways to choose three letters including two *O*'s. There are  $\frac{3!}{2!} = 3$  ways to permute these letters. Thus there are  $4 \cdot 3$  strings of length three that use the two *O*'s, and there are  $5 \cdot 4 \cdot 3$  strings of length three that do not use two *O*'s (formed by selecting a 3-permutation of *SCHOL*). Thus there are 72 strings of length three.

There are  $C(4, 2) = 6$  ways to choose four letters including two *O*'s. There are  $\frac{4!}{2!} = 6$  ways to permute these letters. Thus there are  $6 \cdot 6 = 36$  strings of length four that use the two *O*'s, and there are  $5 \cdot 4 \cdot 3 \cdot 2$  strings of length four that do not use two *O*'s (formed by selecting a 4-permutation of *SCHOL*). Thus there are 156 strings of length four.

There are  $C(4, 3) = 4$  ways to choose five letters including two *O*'s. There are  $\frac{5!}{2!} = 60$  ways to permute these letters. Thus there are  $4 \cdot 60 = 240$  strings of length five that use the two *O*'s, and there are  $5 \cdot 4 \cdot 3 \cdot 2 \cdot 1$  strings of length four that do not use two *O*'s (formed by selecting a 5-permutation of *SCHOL*). Thus there are 360 strings of length five.

There are  $\frac{6!}{2!} = 360$  strings of length six. Thus there are

$$1 + 5 + 21 + 72 + 156 + 360 + 360 = 975$$

strings that can be formed by ordering the letters *SCHOOL* using some or all of the letters.

8.  $C(10 + 6 - 1, 6 - 1)$       9.  $C(4 + 6 - 1, 6 - 1)$
11. Assign each problem five points, and let  $x_i$  denote the number of additional points that can be assigned to problem  $i$ . Now the question is: How many solutions are there of

$$\sum_{i=1}^{12} x_i = 40?$$

Arguing as in Example 6.6.8, the answer is  $C(40 + 12 - 1, 12 - 1)$ .

12.  $4^{100}$       13.  $C(100 + 4 - 1, 4 - 1)$       16.  $C(9 + 3 - 1, 9)$       17.  $C(4 + 3 - 1, 4)$
19.  $C(8 + 2 - 1, 8)$       20.  $C(10 + 2 - 1, 10) + C(9 + 2 - 1, 9)$       23.  $C(12 + 3 - 1, 12)$
24.  $C(14 + 2 - 1, 14)$       26.  $C(15 + 3 - 1, 15) - C(8 + 3 - 1, 8)$



27. There are  $C(14 + 3 - 1, 14)$  solutions satisfying  $0 \leq x_1, 1 \leq x_2, 0 \leq x_3$ . Of these,  $C(8 + 3 - 1, 8)$  have  $x_1 \geq 6$ ;  $C(6 + 3 - 1, 6)$  have  $x_2 \geq 9$ ; and there is one with  $x_1 \geq 6$  and  $x_2 \geq 9$ . Thus there are

$$C(8 + 3 - 1, 8) + C(6 + 3 - 1, 6) - 1$$

solutions with  $x_1 \geq 6$  or  $x_2 \geq 9$ . Therefore there are

$$C(14 + 3 - 1, 14) - [C(8 + 3 - 1, 8) + C(6 + 3 - 1, 6) - 1]$$

of the desired type.

29. The problem is equivalent to solving

$$x_1 + x_2 + \cdots + x_n + x_{n+1} = M$$

since

$$0 \leq x_{n+1} = M - x_1 + x_2 + \cdots + x_n.$$

Thus the number of solutions is

$$C(M + (n + 1) - 1, (n + 1) - 1) = C(M + n, n).$$

30. We must count the number of solutions of

$$x_1 + x_2 + x_3 + x_4 + x_5 + x_6 = 15$$

satisfying  $0 \leq x_i \leq 9, i = 1, \dots, 6$ . There are  $C(15 + 6 - 1, 15)$  solutions with  $x_i \geq 0, i = 1, \dots, 6$ . There are  $C(5 + 6 - 1, 5)$  with  $x_1 \geq 10$ . There are  $6C(5 + 6 - 1, 5)$  with some  $x_i \geq 10$ . (Note that there is no double counting, since we cannot have  $x_i \geq 10$  and  $x_j \geq 10, i \neq j$ .) Thus the solution is  $C(15 + 6 - 1, 15) - 6C(5 + 6 - 1, 5)$ .

31.  $C(20 + 6 - 1, 20) - [6C(10 + 6 - 1, 10) - C(6, 2)]$   
 33.  $8!/(4! \cdot 2! \cdot 2!)$       23.  $C(7 + 2 - 1, 2)$       36.  $C(5 + 3 - 1, 5)$       37.  $C(6, 2)C(6, 3)C(8, 2)$   
 39.  $C(20, 5)C(15, 5)$   
 40.  $[C(20, 5) - C(14, 5)][C(14, 5) + 6C(14, 4)]$       42.  $C(15 + 5 - 1, 15)C(10 + 5 - 1, 10)$   
 43.  $C(12, 10)$   
 45. Consider the number of orderings of  $kn$  objects where there are  $n$  identical objects of each of  $k$  types.  
 46. The number of times the print statement is executed is

$$1 + 2 + \dots + n.$$

Example 6.6.9 shows that this is the same as  $C(2 + n - 1, 2) = (n + 1)n/2$ .

48. `list_sols(n)` {  
     for  $x_1 = 0$  to  $n$   
         for  $x_2 = 0$  to  $n - x_1$   
             `println(x1, x2, n - x1 - x2)`  
     }

49. Many partitions are not counted. For example, the partition

$$\{\{x_1, x_3\}, \{x_2\}, \{x_4\}, \{x_5\}, \{x_6\}, \{x_7\}, \{x_8\}, \{x_9, x_{10}\}\}$$

is not counted.

51. The 10 disks can be given to Mary, Ivan, and Juan in  $C(10+3-1, 3-1)$  ways. If Ivan receives exactly three disks, the remaining seven disks can be given to Mary and Juan in  $C(7+2-1, 2-1)$  ways. Thus the probability that Ivan receives exactly three disks is

$$\frac{C(7+2-1, 2-1)}{C(10+3-1, 3-1)}.$$

## Section 6.7

2.  $32c^5 - 240c^4d + 720c^3d^2 - 1080c^2d^3 + 810cd^4 - 243d^5$

4.  $59136s^6t^6$       5.  $C(10, 2)C(8, 3) = 10!/(2!3!5!)$       7.  $C(5, 2)$       8.  $C(5, 2)$

11.  $C(12+4-1, 12)$       12.  $C(12+3-1, 12) + C(11+3-1, 11) + C(10+3-1, 10)$

14. (a)  $C(n, k) < C(n, k+1)$  if and only if

$$\frac{n!}{k!(n-k)!} < \frac{n!}{(k+1)!(n-k-1)!}$$

if and only if  $k+1 < n-k$  if and only if  $k < (n-1)/2$ .

15. Set  $a = 1$  and  $b = -1$  in the Binomial Theorem.

$$\begin{aligned} 17. \quad C(n, k-1) + C(n, k) &= \frac{n!}{(k-1)!(n-k+1)!} + \frac{n!}{k!(n-k)!} \\ &= \frac{(n!)k}{k!(n-k+1)!} + \frac{(n!)(n-k+1)}{k!(n-k+1)!} \\ &= \frac{(n!)(n+1)}{k!(n-k+1)!} = C(n+1, k). \end{aligned}$$

18. Choosing a  $k$ -element set  $X$  also selects an  $(n-k)$ -element set  $X$ .

20.  $(n+1)n(n-1)/3$

21. Use the fact that  $k^2 = 2C(k, 2) + C(k, 1)$ .

23. Use Exercise 15 and equation (6.7.3).

24. Imitate the combinatorial proof of the Binomial Theorem.
26. Take  $a = b = c = 1$  in Exercise 24.
27. Think of  $C(n, k)^2$  as  $C(n, k)C(n, n - k)$ . Let  $X$  and  $Y$  be disjoint sets each having  $n$  elements. Now,  $C(2n, n)$  is the number of ways of picking  $n$ -element subsets of  $X \cup Y$ . Picking an  $n$ -element subset of  $X \cup Y$  is the same as picking a  $k$ -element subset of  $X$  and an  $(n - k)$ -element subset of  $Y$ .
29. Set  $x = 1$  in Exercise 28.
30. **Inductive Step.**

$$\begin{aligned}
 \sum_{k=1}^{n+1} kC(n+1, k) &= \sum_{k=1}^n k[C(n, k-1) + C(n, k)] + (n+1)C(n+1, n+1) \\
 &= \sum_{k=1}^{n+1} kC(n, k-1) + \sum_{k=1}^n kC(n, k) \\
 &= \sum_{k=1}^{n+1} (k-1)C(n, k-1) + \sum_{k=1}^{n+1} C(n, k-1) + \sum_{k=1}^n kC(n, k) \\
 &= n2^{n-1} + 2^n + n2^{n-1} = (n+1)2^n
 \end{aligned}$$

32. We count the number of ways to choose sets  $A$  and  $B$  with  $A \subseteq B \subseteq X$ . Fix an integer  $k$  with  $0 \leq k \leq n$ . There are  $C(n, k)$  ways to choose a subset  $A$  of  $X$  with  $k$  elements. After choosing such a set  $A$ , there are  $n - k$  elements not in  $A$ , and there are  $2^{n-k}$  ways to choose a subset of them to union with  $A$  to produce a set  $B$  that contains  $A$ . Thus there are  $C(n, k)2^{n-k}$  ways to choose subsets  $A$  and  $B$  satisfying  $A \subseteq B \subseteq X$  in which  $A$  has  $k$  elements. Summing over all  $k$  we obtain the number of ordered pairs  $(A, B)$  satisfying  $A \subseteq B \subseteq X$ :

$$\sum_{k=0}^n C(n, k)2^{n-k}.$$

Taking  $a = 2$  and  $b = 1$  in the Binomial Theorem, we find that this sum is equal to

$$(a + b)^n = (2 + 1)^n = 3^n.$$

33. We use induction. The Basis Step is  $n = m$ :

$$C(m, m)H_m = H_m = C(m + 1, m + 1) \left( H_{m+1} - \frac{1}{m + 1} \right).$$

Assume true for  $n$ . Then

$$\begin{aligned}
 \sum_{k=m}^{n+1} C(k, m)H_k &= \sum_{k=m}^n C(k, m)H_k + C(n + 1, m)H_{n+1} \\
 &= C(n + 1, m + 1) \left( H_{n+1} - \frac{1}{m + 1} \right) + C(n + 1, m)H_{n+1}
 \end{aligned}$$

$$\begin{aligned}
&= C(n+1, m+1) \left( H_{n+2} - \frac{1}{n+2} - \frac{1}{m+1} \right) \\
&\quad + C(n+1, m) \left( H_{n+2} - \frac{1}{n+2} \right) \\
&= [C(n+1, m+1) + C(n+1, m)] H_{n+2} \\
&\quad - \frac{C(n+1, m+1) + C(n+1, m)}{n+2} - \frac{C(n+1, m+1)}{m+1} \\
&= C(n+2, m+1) H_{n+2} - \frac{C(n+2, m+1)}{n+2} - \frac{C(n+1, m+1)}{m+1} \\
&= C(n+2, m+1) H_{n+2} - \frac{C(n+1, m)}{m+1} - \frac{C(n+1, m+1)}{m+1} \quad (6.1) \\
&= C(n+2, m+1) H_{n+2} - \frac{C(n+2, m+1)}{m+1}
\end{aligned}$$

Equality (6.1) follows from the formula

$$C(n+2, m+1) = \frac{n+2}{m+1} C(n+1, m).$$

## Section 6.8

- There are six possible combinations of first and last names. Each of the 18 persons is to be assigned a first and last name. By the Pigeonhole Principle, at least  $\lceil 18/6 \rceil = 3$  of them will be assigned the same first and last names.
- Professor Euclid is paid 26 times per year. Since there are 12 months, by the Pigeonhole Principle, at least  $\lceil 26/12 \rceil = 3$  pay periods will occur in the same month.
- Let  $A = \{x_1, \dots, x_{60}\}$  be the set of positions for the available items. Each  $x_i$  assumes a distinct value in  $\{1, \dots, 115\}$ . Let  $B = \{x_1 + 4, \dots, x_{60} + 4\}$ . The set

$$X = \{x_1, \dots, x_{60}, x_1 + 4, \dots, x_{60} + 4\}$$

of 120 numbers can take on values from 1 to 119. By the Pigeonhole Principle at least two of these 120 elements are identical. Since the elements in  $A$  are distinct, so are the elements in  $B$ . There is an element  $x_i$  in  $A$  and an element in  $x_j + 4$  in  $B$  which are identical.

- Let  $a_i$  denote the position of the  $i$ th available item. The 110 numbers

$$a_1, \dots, a_{55}; \quad a_1 + 9, \dots, a_{55} + 9$$

have values between 1 and 109. By the second form of the Pigeonhole Principle, two must coincide. The conclusion follows.

- If any pair  $(P_i, P_j)$ ,  $(P_i, P_k)$ ,  $(P_k, P_j)$  is dissimilar, then the two dissimilar pictures together with  $P_1$  are three mutually dissimilar pictures. If none of these pairs are dissimilar, then  $P_i$ ,  $P_j$ , and  $P_k$  are three mutually similar pictures.
- No. Consider five pictures  $P_1, \dots, P_5$  in which  $P_1$  is similar to  $P_2$ ;  $P_2$  is similar to  $P_3$ ;  $P_3$  is similar to  $P_4$ ;  $P_4$  is similar to  $P_5$ ;  $P_5$  is similar to  $P_1$ .

10. Yes, since any subset of six pictures has the given property.
15. Let  $n = 2$ , and consider the subset  $\{3, 4, 5\}$  of  $\{1, 2, 3, 4, 5\}$ .
16. Let  $x_i$  denote the longest increasing subsequence and  $y_i$  denote the longest decreasing subsequence starting at  $a_i$ . Consider  $(b_i, c_i)$  and  $(b_j, c_j)$ . We may assume that  $i < j$ . If  $a_i < a_j$ ,  $\{a_i, x_j\}$  is an increasing subsequence starting at  $a_i$  which is longer than  $x_j$ . Hence  $b_i \geq \text{length of } \{a_i, x_j\} > b_j$ . If  $a_i > a_j$ ,  $\{a_i, y_j\}$  is a decreasing subsequence starting at  $a_i$  which is longer than  $y_j$ . Hence  $c_i \geq \text{length of } \{a_i, y_j\} > c_j$ . Since the  $a_k$ 's are distinct, the preceding cases are the only cases. For each, we have shown that  $(b_i, c_i)$  and  $(b_j, c_j)$  are distinct.
17. The number of ordered pairs  $(b_i, c_i)$  is  $m = n^2 + 1$ , one for each  $i = 1, \dots, m$ .
18. By assumption, every increasing or decreasing subsequence has length less than or equal to  $n$ . Thus  $1 \leq b_i \leq n$  and  $1 \leq c_i \leq n$ .
19. By Exercise 17, we have  $n^2 + 1$  pairs  $(b_i, c_i)$ . By Exercise 18, these pairs can take on only  $n^2$  values. By the Pigeonhole Principle, at least two of these pairs must be identical. This contradicts the result of Exercise 16.
20. If  $r_i \leq 8$ , since  $r_i \geq 0$  and  $s_i = r_i$ , we have  $0 \leq s_i \leq 8$ .  
If  $r_i > 8$ , since  $r_i \leq 15$ , we have  $1 \leq 16 - r_i < 8$ . Thus  $1 \leq s_i < 8$ .
21. The set  $\{s_1, \dots, s_{10}\}$  is a subset of the 9-element set  $\{0, \dots, 8\}$ . By the second form of the Pigeonhole Principle,  $s_j = s_k$  for  $j \neq k$ .
22. Suppose that  $s_j = r_j$  and  $s_k = r_k$ . Then  $r_j = r_k$ , so  $a_j \bmod 16 = a_k \bmod 16$ . Therefore 16 divides  $a_j - a_k$ .  
If  $s_j = 16 - r_j$  and  $s_k = 16 - r_k$ , we again find that  $r_j = r_k$  and the conclusion follows.
23. We may suppose that  $s_j = r_j$  and  $s_k = 16 - r_k$ . Thus  $r_j = 16 - r_k$  so  $r_j + r_k = 16$ . By definition,

$$a_j \bmod 16 = r_j \quad \text{and} \quad a_k \bmod 16 = r_k$$

so there are integers  $q_j$  and  $q_k$  satisfying

$$a_j = 16q_j + r_j \quad \text{and} \quad a_k = 16q_k + r_k.$$

Now

$$\begin{aligned} a_j + a_k &= 16(q_j + q_k) + r_j + r_k \\ &= 16(q_j + q_k) + 16 \\ &= 16(q_j + q_k + 1). \end{aligned}$$

Therefore 16 divides  $a_j + a_k$ .

25. Suppose that the numbers around the circle are  $x_1, \dots, x_{12}$ . We argue by contradiction. Suppose that

$$\begin{aligned} x_1 + x_2 + x_3 &\leq 19 \\ x_2 + x_3 + x_4 &\leq 19 \\ &\vdots \\ x_{10} + x_{11} + x_{12} &\leq 19 \\ x_{11} + x_{12} + x_1 &\leq 19 \\ x_{12} + x_1 + x_2 &\leq 19. \end{aligned}$$

Summing, we obtain the contradiction

$$234 = 3 \left( \frac{12 \cdot 13}{2} \right) = 3(x_1 + \dots + x_{12}) \leq 12 \cdot 19 = 228.$$

26. The sum of some four consecutive players' numbers must be at least 26. Suppose that

$$\begin{aligned} x_1 + x_2 + x_3 + x_4 &\leq 25 \\ x_2 + x_3 + x_4 + x_5 &\leq 25 \\ &\vdots \\ x_{12} + x_1 + x_2 + x_3 &\leq 25 \end{aligned}$$

Summing, we obtain the contradiction

$$312 = 4 \left( \frac{12 \cdot 13}{2} \right) = 4(x_1 + \dots + x_{12}) \leq 12 \cdot 25 = 300.$$

27. Each of the  $n! + 1$  functions

$$f, f^2, f^3, \dots, f^{n!+1}$$

is a permutation of  $\{1, \dots, n\}$ . Since there are  $n!$  permutations of  $\{1, \dots, n\}$ , by the Pigeonhole Principle,

$$f^i = f^j \tag{6.2}$$

for some distinct positive integers  $i$  and  $j$ .

Notice that if we compose each side of (6.2) with  $f^{-1}$ , we obtain

$$f^{i-1} = f^{j-1}.$$

We may assume that  $i > j$ . If we compose each side of (6.2) with  $f^{-1}$   $j$  times, we obtain

$$f^{i-j} = I,$$

where  $I(x) = x$  for  $x = 1, \dots, n$ . We may take  $k = i - j$  to obtain the desired conclusion.

29. Suppose that the numbers around the circle are  $x_1, \dots, x_{p+q}$ . We argue by contradiction. Suppose that each consecutive group of  $k$  numbers contains a zero. Then each consecutive group of  $k$  numbers sums to  $k - 1$  or less. Thus

$$\begin{aligned} x_1 + \cdots + x_k &\leq k - 1 \\ x_2 + \cdots + x_{k+1} &\leq k - 1 \\ &\vdots \\ x_{p+q} + x_1 + \cdots + x_{k-1} &\leq k - 1 \end{aligned}$$

Summing, we obtain

$$kp = k(x_1 + \cdots + x_{p+q}) \leq (p+q)(k-1)$$

or

$$p \leq (k-1)q.$$

Since  $p \geq kq > (k-1)q$ , this is a contradiction.

30. See Section 6.11.1, pages 167–169, of U. Manber, *Introduction to Algorithms*, Addison-Wesley, Reading, Mass., 1989.
31. Suppose that it is possible to mark  $k$  squares in the upper-left,  $k \times k$  subgrid and  $k$  squares in the lower-right,  $k \times k$  subgrid so that no two marked squares are in the same row, column, or diagonal of the  $2k \times 2k$  grid. Then the  $2k$  marked squares are contained in  $2k - 1$  diagonals. One diagonal begins at the top left square and runs to the bottom right square;  $k - 1$  diagonals begin at the  $k - 1$  squares immediately to the right of the top left square and run parallel to the first diagonal described; and  $k - 1$  diagonals begin at the  $k - 1$  squares immediately under the top left square and run parallel to the others described. By the Pigeonhole Principle, some diagonal contains two marked squares. This contradiction shows that it is impossible to mark  $k$  squares in the upper-left,  $k \times k$  subgrid and  $k$  squares in the lower-right,  $k \times k$  subgrid so that no two marked squares are in the same row, column, or diagonal of the  $2k \times 2k$  grid.





## Chapter 7

# Solutions to Selected Exercises

### Section 7.1

2.  $a_n = a_{n-1} + a_{n-2}; a_1 = 3, a_2 = 6$

3.  $a_n = 2a_{n-1}a_{n-2}; a_1 = a_2 = 1$

9.  $A_n = 1.10A_{n-1} + 2000$

10.  $A_0 = 2000$

11.  $A_1 = 4200, A_2 = 6620, A_3 = 9282$

12. 
$$\begin{aligned} A_n &= 1.10A_{n-1} + 2000 \\ &= 1.10(1.10A_{n-2} + 2000) + 2000 \\ &= 1.10^2A_{n-2} + (1.10)2000 + 2000 \\ &= 1.10^2(1.10A_{n-3} + 2000) + (1.10)2000 + 2000 \\ &= 1.10^3A_{n-3} + (1.10^2)2000 + (1.10)2000 + 2000 \\ &\vdots \\ &= 1.10^nA_0 + (1.10^{n-1})2000 + (1.10^{n-2})2000 + \cdots + (1.10)2000 + 2000 \\ &= (1.10^n)2000 + (1.10^{n-1})2000 + (1.10^{n-2})2000 + \cdots + (1.10)2000 + 2000 \\ &= \frac{(1.10^{n+1})2000 - 2000}{1.10 - 1} \\ &= 20000(1.10^{n+1} - 1) \end{aligned}$$

13.  $A_n = (1.03)^4A_{n-1}$

14.  $A_0 = 3000$

15.  $A_1 = 3376.53, A_2 = 3800.31, A_3 = 4277.28$

16.  $A_n = (1.03)^{4n}3000$

17. 5.86

20. An  $n$ -bit string that does not contain the pattern 00 either begins 1 and is followed by an  $(n-1)$ -bit string that does not contain 00, or it begins 01 and is followed by an  $(n-2)$ -bit string that does not contain 00. Thus we obtain the recurrence relation

$$S_n = S_{n-1} + S_{n-2},$$

which is the same recurrence relation that the Fibonacci sequence  $f$  satisfies. The initial conditions for the sequence  $S$  are

$$S_1 = 2, S_2 = 3.$$

Since  $f_3 = 2$  and  $f_4 = 3$ , the result follows.

21. We count the number of  $n$ -bit strings with exactly  $i$  0's that do not contain the pattern 00. Such a string has  $n-i$  1's:

— 1 — 1 — . . . — 1 — .

To avoid the pattern 00, the 0's must be placed in the  $n - i + 1$  spaces. This can be done in  $C(n - i + 1, i)$  ways. Thus there are

$$\sum_{i=0}^{\lfloor (n+1)/2 \rfloor} C(n+1-i, i) \quad (7.1)$$

$n$ -bit strings that do not contain the pattern 00. By Exercise 20, (7.1) is equal to  $f_{n+2}$ .

23. We count the number of strings not containing 010 having  $i$  leading 0's. For  $i = 0$ , there are  $S_{n-1}$  such strings. For  $i = 1$ , the string begins 011, so there are  $S_{n-3}$  such strings. Similarly, for  $i = 2$ , there are  $S_{n-4}$  such strings; . . . for  $i = n - 3$ , there are  $S_1$  such strings. For  $i = n - 2$ ,  $n - 1$ , or  $n$ , there is one such string. The equation now follows.
24. The formula for  $n - 1$  is

$$S_{n-1} = S_{n-2} + S_{n-4} + S_{n-5} + \cdots + S_1 + 3.$$

Subtracting  $S_{n-1}$  from  $S_n$ , we obtain

$$S_n - S_{n-1} = S_{n-1} + S_{n-3} - S_{n-2}.$$

Solving for  $S_n$ , we obtain the desired recurrence relation.

26. We use the explicit formula for the  $n$ th Catalan number derived in Example 6.2.22 to obtain

$$\begin{aligned} (n+2)C_{n+1} &= \frac{(n+2)C(2n+2, n+1)}{n+2} \\ &= \frac{(2n+2)!}{(n+1)!(n+1)!} \\ &= \frac{2(2n+1)(2n)!(2n+2)}{(n+1)n!(2n+2)} \\ &= \frac{(4n+2)(2n)!}{(n+1)n!n!} \\ &= \frac{(4n+2)C(2n, n)}{n+1} = (4n+2)C_n. \end{aligned}$$

27. The proof is by induction on  $n$  with the Basis Step omitted.

Assume that the inequality holds for  $n$ . We use the formula from Exercise 26 to derive

$$C_{n+1} = \frac{4n+2}{n+2} C_n \geq \frac{4n+2}{n+2} \frac{4^{n-1}}{n^2} \geq \frac{4^n}{(n+1)^2}.$$

The last inequality is successively equivalent to

$$\begin{aligned} \frac{4n+2}{(n+2)n^2} &\geq \frac{4}{(n+1)^2} \\ (2n+1)(n+1)^2 &\geq 2(n+2)n^2 \\ 2n^3 + 5n^2 + 4n + 1 &\geq 2n^3 + 4n^2 \\ n^2 + 4n + 1 &\geq 0, \end{aligned}$$

which is clearly true for all  $n \geq 1$ .

28. Let  $b_n$  denote the number of ways to parenthesize the product

$$a_1 * \cdots * a_{n+1}.$$

Then  $b_0 = b_1 = 1$ .

Suppose that  $n > 1$ ,  $1 \leq i \leq n$ , and that the multiplication is carried out by multiplying

$$a_1 * \cdots * a_i, \tag{7.2}$$

parenthesized in some way, by

$$a_{i+1} * \cdots * a_{n+1}, \tag{7.3}$$

parenthesized in some way. There are  $b_{i-1}$  ways to parenthesize (7.2) and  $b_{n-i}$  ways to parenthesize (7.3). Therefore there are  $b_{i-1}b_{n-i}$  ways to parenthesize the product

$$a_1 * \cdots * a_{n+1}.$$

if the multiplication is carried out by multiplying (7.2), parenthesized in some way, by (7.3), parenthesized in some way. Summing over all  $i$  we obtain

$$b_n = \sum_{i=1}^n b_{i-1}b_{n-i}.$$

Since the sequence  $\{b_n\}$  satisfies the same initial condition and recurrence relation as the Catalan sequence  $\{C_n\}$ , it follows that  $b_n = C_n$  for all  $n$ .

30. We assume that the paths start at  $(0, 0)$  and end at  $(n, n)$ . Suppose that a route first meets the diagonal at  $(k+1, k+1)$ . It is either always below the diagonal [from  $(1, 0)$  to  $(k+1, k)$ ] or always above the diagonal [from  $(0, 1)$  to  $(k, k+1)$ ]. Thus there are  $2C_k$  such paths from  $(0, 0)$  to  $(k+1, k+1)$ . There are  $C(2(n+1-(k+1)), n+1-(k+1)) = C(2(n-k), n-k)$  paths from  $(k+1, k+1)$  to  $(n+1, n+1)$  (with no restrictions). Thus the number of paths that first meet the diagonal at  $(k+1, k+1)$  is  $C_k C(2(n-k), n-k)$ .

Since there are  $C(2(n+1), n+1)$  paths from  $(0, 0)$  to  $(n+1, n+1)$  (with no restrictions),

$$C(2(n+1), n+1) = \sum_{k=0}^n 2C_k C(2(n-k), n-k).$$

Thus

$$C(2(n+1), n+1) = 2C_n + \sum_{k=0}^{n-1} 2C_k C(2(n-k), n-k).$$

Dividing by 2 and moving the last summation to the left side of the equation gives the desired result.

32. We assume that the paths start at  $(0, 0)$  and end at  $(n, n)$ . Let  $D_i$  denote the number of paths that first touch the diagonal at  $(i, i)$  after leaving  $(0, 0)$ . Then

$$S_n = D_1 + D_2 + \cdots + D_n.$$

Since  $D_1$  is the product of the number of paths from  $(0, 0)$  to  $(1, 1)$  and the number of paths from  $(1, 1)$  to  $(n, n)$ ,

$$D_1 = 2S_{n-1}.$$

If  $i \geq 2$ ,  $D_i$  is the product of the number of paths from  $(1, 0)$  to  $(i, i-1)$  and the number of paths from  $(i, i)$  to  $(n, n)$ , so

$$D_i = S_{i-1}S_{n-i}.$$

Thus

$$S_n = 2S_{n-1} + \sum_{i=2}^n S_{i-1}S_{n-i}.$$

34. price =  $ak/(k+b)$ , quantity =  $a/(k+b)$

36. We have

$$|p_{n+1} - p_n| = \left| a - \frac{b}{k}p_n - a + \frac{b}{k}p_{n-1} \right| = \left| \frac{b}{k}(p_{n-1} - p_n) \right| = \frac{b}{k}|p_n - p_{n-1}|.$$

Now  $b > k$ , so  $b/k > 1$ . Thus  $|p_{n+1} - p_n| > |p_n - p_{n-1}|$ .

38. **Basis Step.**  $A(1, 0) = A(0, 1) = 2$

**Inductive Step.**  $A(1, n+1) = A(0, A(1, n)) = A(0, n+2) = n+3$

39. **Basis Step.**  $A(2, 0) = A(1, 1) = 3$  by Exercise 38.

**Inductive Step.** Assume that the statement is true for  $n$ . Then

$$\begin{aligned} A(2, n+1) &= A(1, A(2, n)) \\ &= A(1, 3+2n) && \text{by the inductive assumption} \\ &= 3+2n+2 && \text{by Exercise 38} \\ &= 2n+5. \end{aligned}$$

41. **Basis Step.** ( $m=0$ ).  $A(0, n) = n+1 > n$  for all  $n \geq 0$ .

**Inductive Step.** Assume that  $A(m, n) > n$  for all  $n \geq 0$ . We use induction on  $n$  to prove that

$$A(m+1, n) > n \quad \text{for all } n \geq 0.$$

**Basis Step** ( $n=0$ ).

$$\begin{aligned} A(m+1, n) &= A(m+1, 0) \\ &= A(m, 1) \\ &> 1 && \text{by the original inductive assumption} \\ &> 0 = n. \end{aligned}$$

**Inductive Step.**

$$\begin{aligned} A(m+1, n+1) &= A(m, A(m+1, n)) \\ &> A(m+1, n) && \text{by the original inductive assumption} \\ &> n && \text{by the present inductive assumption.} \end{aligned}$$

Now

$$A(m+1, n+1) > A(m+1, n) \geq n+1,$$

which completes the current inductive step. Therefore

$$A(m+1, n) > n$$

for all  $n \geq 0$ . Thus the original induction is complete.

42. If  $n = 0$ ,  $A(m, 0) = A(m-1, 1) > 1$  by Exercise 41.

If  $n > 0$ ,  $A(m, n) > n \geq 1$  by Exercise 41.

45. **Basis Step** ( $x = 2$ ).  $AO(2, 2, 1) = 2 \cdot 1 = 2$ .

**Inductive Step.** Assume that the statement is true for  $x$ . Now

$$AO(x+1, 2, 1) = AO(x, 2, AO(x+1, 2, 0)) = AO(x, 2, 1) = 2.$$

46. **Inductive Step.**

$$\begin{aligned} AO(x+1, 2, 2) &= AO(x, 2, AO(x+1, 2, 1)) \\ &= AO(x, 2, 2) && \text{by Exercise 45} \\ &= 4 \end{aligned}$$

48. (a)  $a_2 = 1$  because two nodes must establish one link to share files.

Suppose that we have three nodes  $A$ ,  $B$ , and  $C$ . If the following successive links are established,

$$A \leftrightarrow B, \quad A \leftrightarrow C, \quad A \leftrightarrow B,$$

then all nodes know all files. Since three links suffice,  $a_3 \leq 3$ .

Suppose that we have four nodes  $A$ ,  $B$ ,  $C$ , and  $D$ . If the following successive links are established,

$$A \leftrightarrow B, \quad C \leftrightarrow D, \quad A \leftrightarrow C, \quad B \leftrightarrow D,$$

then all nodes know all files. Since four links suffice,  $a_4 \leq 4$ .

(b) Suppose that we have  $n \geq 3$  nodes. Let  $A$  and  $B$  be nodes. First  $A$  and  $B$  share files. Next, all nodes except  $A$  share files (requiring  $a_{n-1}$  links). Finally,  $A$  and  $B$  again share files. At this point all nodes know all files. Thus  $a_n \leq a_{n-1} + 2$ .

49.  $P_1 = 1$ ,  $P_n = nP_{n-1}$

51. Suppose that we have  $n$  dollars. If we buy tape the first day, there are  $R_{n-1}$  ways to spend the remaining money. If we buy paper the first day, there are  $R_{n-1}$  ways to spend the remaining money. If we buy pens the first day, there are  $R_{n-2}$  ways to spend the remaining money. If we buy pencils the first day, there are  $R_{n-2}$  ways to spend the remaining money. If we buy binders the first day, there are  $R_{n-3}$  ways to spend the remaining money. Thus

$$R_n = 2R_{n-1} + 2R_{n-2} + R_{n-3}.$$

52. Because of the assumptions, when the  $(n + 1)$ st line  $L$  is added, it will intersect the other  $n$  lines. If we imagine traveling along  $L$ , each time we pass through one of the original regions, we divide it into two regions. Since we pass through  $n + 1$  regions,  $R_{n+1} = R_n + n + 1$ .
54.  $S_n = \frac{2}{3} \left[ 1 - \left(-\frac{1}{2}\right)^{n-1} \right]$
56. A string  $\alpha$  of length  $n$  with  $C(\alpha) \leq 2$  either begins with 1 (there are  $S_{n-1}$  of these), 01 (there are  $S_{n-2}$  of these), or 001 (there are  $S_{n-3}$  of these). Thus  $S_n = S_{n-1} + S_{n-2} + S_{n-3}$ .
57. **Basis Steps** ( $n = 1, 2$ ).

$$2f_2 - 1 = 2 - 1 = 1 = g_1, \quad 2f_3 - 1 = 4 - 1 = 3 = g_2$$

**Inductive Step.**

$$g_n = g_{n-1} + g_{n-2} + 1 = (2f_n - 1) + (2f_{n-1} - 1) + 1 = 2(f_n + f_{n-1}) - 1 = 2f_{n+1} - 1$$

59. The problem is that the Inductive Step assumes *two* previous cases, but the Basis Step proves only *one*.
60.  $C(n + 1, k) = C(n, k - 1) + C(n, k)$
62. There are  $k^n$  functions from  $X = \{1, \dots, n\}$  onto  $Y = \{1, \dots, k\}$ . We will count the number  $N$  of functions from  $X$  into, but not onto,  $Y$ . Then, the number of functions from  $X$  onto  $Y$  will be  $k^n - N$ .

Let  $Z$  be a proper, nonempty subset of  $Y$  with  $i$  elements. There are  $S(n, i)$  functions from  $X$  onto  $Z$ . The number of subsets of  $Y$  having  $i$  elements is  $C(k, i)$ . Then, there are  $C(k, i)S(n, i)$  functions from  $X$  onto some  $i$ -element subset of  $Y$ . If a function from  $X$  to  $Y$  is not onto  $Y$ , it is onto some proper nonempty subset of  $Y$ . The result follows.

63. (a)  $L_3 = 4, L_4 = 7, L_5 = 11$   
 (b) **Basis Step** ( $n = 1, 2$ ).

$$\begin{aligned} L_3 &= 4 = 1 + 3 = f_2 + f_4 \\ L_4 &= 7 = 2 + 5 = f_3 + f_5 \end{aligned}$$

**Inductive Step.** Assume that  $L_{n+1} = f_n + f_{n+2}$  and  $L_{n+2} = f_{n+1} + f_{n+3}$ . Now

$$\begin{aligned} L_{n+3} &= L_{n+2} + L_{n+1} = f_{n+1} + f_{n+3} + f_n + f_{n+2} \\ &= (f_n + f_{n+1}) + (f_{n+2} + f_{n+3}) \\ &= f_{n+2} + f_{n+4}. \end{aligned}$$

65. Let  $X$  be an  $(n + 1)$ -element set and choose an element  $x \in X$ . We count the number of partitions of  $X$  containing  $k$  subsets in which  $x$  appears as a singleton and the number of partitions of  $X$  containing  $k$  subsets in which  $x$  appears in a subset with at least two elements. A partition of  $X$  containing  $k$  subsets in which  $x$  appears as a singleton consists of  $\{x\}$  together with a partition of  $X - \{x\}$  containing  $k - 1$  subsets. There are  $S_{n, k-1}$  such partitions.

A partition of  $X$  containing  $k$  subsets in which  $x$  appears in a subset with at least two elements can be constructed in the following way. Select a partition of  $X - \{x\}$  containing  $k$  subsets. This can be done in  $S_{n,k}$  ways. Next add  $x$  to one of the subsets. This can be done in  $k$  ways. Thus there are  $kS_{n,k}$  partitions of  $X$  containing  $k$  subsets in which  $x$  appears in a subset with at least two elements. The recurrence relation now follows.

66. We prove the formula by induction on  $n$  leaving the Basis Step ( $n = 1$ ) to the reader.

Assume that the formula is true for  $n$ . We must prove the formula is true for  $n + 1$ . If  $k = 0$ , the formula is clearly true, so assume that  $k > 0$ . By Exercise 62,

$$\begin{aligned}
 S_{n+1,k} &= S_{n,k-1} + kS_{n,k} \\
 &= \frac{1}{(k-1)!} \sum_{i=0}^{k-1} (-1)^i (k-1-i)^n C(k-1, i) + \frac{k}{k!} \sum_{i=0}^k (-1)^i (k-i)^n C(k, i) \\
 &= \frac{1}{(k-1)!} \left[ \sum_{i=0}^{k-1} (-1)^i (k-1-i)^n C(k-1, i) + \sum_{i=0}^k (-1)^i (k-i)^n C(k, i) \right] \\
 &= \frac{1}{(k-1)!} \left[ k^n C(k, 0) + \sum_{i=1}^k \{(-1)^{i-1} (k-i)^n C(k-1, i-1) + (-1)^i (k-i)^n C(k, i)\} \right] \\
 &= \frac{1}{(k-1)!} \left[ k^n C(k, 0) + \sum_{i=1}^k (-1)^i (k-i)^n [-C(k-1, i-1) + C(k, i)] \right] \\
 &= \frac{1}{(k-1)!} \left[ k^n C(k, 0) + \sum_{i=1}^k (-1)^i (k-i)^n C(k-1, i) \right] \\
 &= \frac{1}{(k-1)!} \left[ \frac{k^{n+1} C(k, 0)}{k} + \sum_{i=1}^k (-1)^i (k-i)^n \frac{C(k, i)(k-i)}{k} \right] \\
 &= \frac{1}{k!} \sum_{i=0}^k (-1)^i (k-i)^{n+1} C(k, i).
 \end{aligned}$$

68.  $a_n = n(a_{n-1} + 1)$

70. 1,5,2,4,3; 1,5,3,4,2; 2,5,1,4,3; 2,5,3,4,1; 3,5,1,4,2; 3,5,2,4,1; 4,5,1,3,2; 4,5,2,3,1; 1,3,2,5,4; 2,3,1,5,4; 1,4,2,5,3; 2,4,1,5,3; 1,4,3,5,2; 3,4,1,5,2; 2,4,3,5,1; 3,4,2,5,1;  $E_5 = 16$

71. An item in the first, third, ... position has a larger neighbor; therefore,  $n$  cannot be in any of these positions.

73. The solution is similar to that of Exercise 72, which is given in the book, except that the portion following 1 must be a "fall/rise" permutation. However, the number of "fall/rise" permutations of  $1, \dots, n$  is equal to the number of "rise/fall" permutations of  $1, \dots, n$ , so the argument proceeds as in the solution to Exercise 72.

74. Add the recurrence relations of Exercises 72 and 73.

## Section 7.2

2. No      3. No      5. Yes; order 3      6. No      8. Yes; order 2

9. Yes; order 2      12.  $a_n = 2^n n!$

$$\begin{aligned} 13. \quad a_n &= a_{n-1} + n = a_{n-2} + (n-1) + n = \cdots \\ &= a_0 + 1 + 2 + \cdots + n = 1 + 2 + \cdots + n = \frac{n(n+1)}{2} \end{aligned}$$

$$\begin{aligned} 14. \quad a_n &= 2^n a_{n-1} = 2^n 2^{n-1} a_{n-2} = 2^n 2^{n-1} 2^{n-2} a_{n-3} = \cdots = 2^n 2^{n-1} 2^{n-2} \cdots 2^1 a_0 \\ &= 2^{n+(n-1)+\cdots+1} = 2^{n(n+1)/2} \end{aligned}$$

16. Solving  $t^2 - 7t + 10 = (t-2)(t-5)$ , we obtain two roots  $t = 2$  and  $t = 5$ . Thus there exist constants  $b$  and  $d$  such that  $a_n = b2^n + d5^n$ . The initial conditions require that  $5 = b + d$  and  $16 = 2b + 5d$ . Solving these two equations simultaneously for  $b$  and  $d$ , we obtain  $b = 3$  and  $d = 2$ . Thus

$$a_n = 3 \cdot 2^n + 2 \cdot 5^n.$$

17. The roots of

$$t^2 - 2t - 8 = 0$$

are 4 and  $-2$ . Thus the solution is  $a_n = b4^n + d(-2)^n$ . To satisfy the initial conditions, we must have

$$\begin{aligned} 4 &= b + d \\ 10 &= 4b - 2d. \end{aligned}$$

Solving, we find  $b = 3$  and  $d = 1$ . Thus the solution is

$$a_n = 3 \cdot 4^n + (-2)^n.$$

$$\begin{aligned} 19. \quad a_n &= a_{n-1} + 1 + 2^{n-1} \\ &= (a_{n-2} + 1 + 2^{n-2}) + 1 + 2^{n-1} \\ &= a_{n-2} + 2 + 2^{n-1} + 2^{n-2} = \cdots \\ &= a_0 + n + 2^{n-1} + 2^{n-2} + \cdots + 1 = n + 2^n - 1 \end{aligned}$$

$$20. \quad a_n = 3^n - 2n3^{n-1} \qquad 22. \quad a_n = 6\left(\frac{1}{3}\right)^n + 9n\left(\frac{1}{3}\right)^n$$

$$23. \quad \text{Similar to Example 7.2.13} \qquad 25. \quad s_n = \frac{n(n+1)}{2} + 1$$

$$26. \quad S_n = \frac{2}{3} \left[ 1 - \left(-\frac{1}{2}\right)^{n-1} \right]$$

27. Let  $p$  be the population of Utopia in 1970. Arguing as in Example 7.1.3, we find that  $n$  years after 1970, the population of Utopia is  $(1.05)^n p$ . Therefore  $10000 = (1.05)^{30} p$ . Solving for  $p$ , we find that the population of Utopia in 1970 was  $p = 2314$ .

$$30. \quad 0 \qquad 31. \quad 1 \qquad 33. \quad \frac{T}{S+T}$$



34. The recurrence relation becomes  $b_n = b_{n-1} + 2b_{n-2}$ . Solving gives  $a_n = b_n^2 = \frac{1}{9} [2^{n+1} + (-1)^n]^2$ .
35. Taking the logarithm to the base 2 of both sides of the equation, we obtain

$$\lg a_n = \frac{1}{2}(\lg a_{n-2} - \lg a_{n-1}).$$

If we let  $b_n = \lg a_n$ , we obtain

$$b_n = \frac{-b_{n-1} + b_{n-2}}{2}.$$

The quadratic equation

$$t^2 + \frac{t}{2} - \frac{1}{2} = 0$$

has two roots,  $\frac{1}{2}$  and  $-1$ . Thus there exist constants  $p$  and  $q$  such that

$$b_n = p \left(\frac{1}{2}\right)^n + q(-1)^n.$$

Now

$$b_0 = \lg a_0 = \lg 8 = 3$$

and a similar calculation shows that  $b_1 = -\frac{3}{2}$ . Therefore

$$\begin{aligned} 3 &= p + q \\ -\frac{3}{2} &= \frac{p}{2} - q. \end{aligned}$$

Solving for  $p$  and  $q$ , we obtain  $p = 1$  and  $q = 2$ . Thus

$$b_n = \left(\frac{1}{2}\right)^n + 2(-1)^n$$

and

$$a_n = 2^{b_n} = 2^{[(1/2)^n + 2(-1)^n]}.$$

37. Subtracting the given recurrence relation from the recurrence relation for  $n + 1$

$$c_{n+1} = 2 + \sum_{i=1}^n c_i.$$

gives

$$c_{n+1} - c_n = c_n$$

so

$$c_{n+1} = 2c_n, \quad n \geq 2.$$

This last recurrence relation can be solved by iteration to yield

$$c_{n+1} = 2c_n = 2^2 c_{n-1} = \cdots = 2^{n-1} c_2 = 3 \cdot 2^{n-1}.$$

for  $n \geq 2$ . By inspection, the formula also holds for  $n = 1$ . Thus we obtain the formula

$$c_n = 3 \cdot 2^{n-2},$$

for  $n \geq 2$ .

38. Let  $S(n, m) = A(n, m) - C(n, m) + 1$ . [ $C(n, m)$  is the number of  $m$ -element subsets of an  $n$ -element set.] Then  $S(n, n) = 1 = S(n, 0)$ . Also

$$\begin{aligned} S(n-1, m-1) + S(n-1, m) &= A(n-1, m-1) - C(n-1, m-1) + 1 \\ &\quad + A(n-1, m) - C(n-1, m) + 1 \\ &= A(n, m) - C(n, m) + 1 = S(n, m). \end{aligned}$$

Since  $\{S(n, m)\}$  and  $\{C(n, m)\}$  satisfy the same recurrence relation and have the same initial conditions, they are equal. Therefore

$$A(n, m) = S(n, m) + C(n, m) - 1 = 2C(n, m) - 1.$$

40. Show that  $U_n - g(n)$  satisfies

$$a_n = c_1 a_{n-1} + c_2 a_{n-2}.$$

42. Assume that

$$g(n) = C_1 n + C_0$$

is a solution. We must have

$$C_1 n + C_0 = 7[C_1(n-1) + C_0] - 10[C_1(n-2) + C_0] + 16n.$$

The coefficient of  $n$  on the left must equal the coefficient of  $n$  on the right:

$$C_1 = 7C_1 - 10C_1 + 16.$$

Thus  $C_1 = 4$ .

The constant on the left must equal the constant on the right:

$$C_0 = -7C_1 + 7C_0 + 20C_1 - 10C_0.$$

Thus  $C_0 = 13$ . Therefore

$$g(n) = 4n + 13.$$

The general solution of

$$a_n = 7a_{n-1} - 10a_{n-2}$$

is

$$b2^n + d5^n.$$

Thus the general solution of the original recurrence relation is

$$a_n = b2^n + d5^n + 4n + 13.$$

43. Assume that

$$g(n) = C_2 n^2 + C_1 n + C_0$$

is a solution. We must have

$$C_2 n^2 + C_1 n + C_0 = 2[C_2(n-1)^2 + C_1(n-1) + C_0] + 8[C_2(n-2)^2 + C_1(n-2) + C_0] + 81n^2.$$

The coefficient of  $n^2$  on the left must equal the coefficient of  $n^2$  on the right:

$$C_2 = 2C_2 + 8C_2 + 81.$$

Thus  $C_2 = -9$ .

The coefficient of  $n$  on the left must equal the coefficient of  $n$  on the right:

$$C_1 = -4C_2 + 2C_1 - 32C_2 + 8C_1.$$

Thus  $C_1 = -36$ .

The constant on the left must equal the constant on the right:

$$C_0 = 2C_2 - 2C_1 + 2C_0 + 32C_2 - 16C_1 + 8C_0.$$

Thus  $C_0 = -38$ . Therefore

$$g(n) = -9n^2 - 36n - 38.$$

The general solution of

$$a_n = 2a_{n-1} + 8a_{n-2}$$

is

$$a_n = b4^n + d(-2)^n.$$

Thus the general solution of the original recurrence relation is

$$a_n = b4^n + d(-2)^n - 9n^2 - 36n - 38.$$

45.  $a_n = b4^n + dn4^n + \frac{3}{25}n + \frac{24}{125}$

46.  $a_n = b(1/3)^n + dn(1/3)^n + (5/4)n^2 - (5/2)n + 25/8$

48. We must have

$$\begin{aligned} C_0 &= a_0 = b \\ C_1 &= a_1 = b + d. \end{aligned}$$

Set  $b = C_0$  and  $d = C_1 - C_0$ .

49. By Exercise 48, Section 7.1, we have

$$a_n \leq a_{n-1} + 2, \quad n \geq 4; \quad a_4 \leq 4.$$

Now

$$\begin{aligned} a_n &\leq a_{n-1} + 2 \leq a_{n-2} + 2 + 2 < \cdots \\ &\leq a_{n-i} + 2i \leq \cdots \\ &\leq a_4 + 2(n-4) \leq 4 + 2(n-4) = 2n - 4. \end{aligned}$$

51.

| $n$ | $T(n)$ | <i>Opt Moves for 3-Peg Problem</i> |
|-----|--------|------------------------------------|
| 1   | 1      | 1                                  |
| 2   | 3      | 3                                  |
| 3   | 5      | 7                                  |
| 4   | 9      | 15                                 |
| 5   | 13     | 31                                 |
| 6   | 17     | 63                                 |
| 7   | 25     | 127                                |
| 8   | 33     | 255                                |
| 9   | 41     | 511                                |
| 10  | 49     | 1023                               |

52. We show only the inductive step. Using the recurrence relation of Exercise 50 and the inductive assumption, we have

$$T(n) = 2T(n - k_n) + 2^{k_n} - 1 = 2[(k_{n-k_n} + r_{n-k_n} - 1)2^{k_n-k_n} + 1] + 2^{k_n} - 1.$$

First suppose that

$$n - k_n < \sum_{i=1}^{k_n} i.$$

Since

$$\sum_{i=1}^{k_n} i \leq n,$$

it follows that

$$\sum_{i=1}^{k_n-1} i \leq n - k_n.$$

Therefore,

$$k_{n-k_n} = k_n - 1.$$

Also,

$$r_n = n - \sum_{i=1}^{k_n} i = n - k_n - \sum_{i=1}^{k_n-1} i = r_{n-k_n}.$$

Now

$$\begin{aligned} T(n) &= 2[(k_{n-k_n} + r_{n-k_n} - 1)2^{k_n-k_n} + 1] + 2^{k_n} - 1 \\ &= 2[(k_n - 1 + r_n - 1)2^{k_n-1} + 1] + 2^{k_n} - 1 \\ &= (k_n - 1 + r_n - 1)2^{k_n} + 2 + 2^{k_n} - 1 \\ &= (k_n + r_n - 1)2^{k_n} + 1. \end{aligned}$$

The case

$$n - k_n = \sum_{i=1}^{k_n} i$$

is treated similarly. (In this case,  $k_{n-k_n} = k_n$  and  $r_{n-k_n} = 0$ .)

53. Since  $k_n$  is the largest integer satisfying

$$\sum_{i=1}^{k_n} i = \frac{k_n(k_n + 1)}{2} \leq n,$$

if we solve the equation

$$\frac{x(x + 1)}{2} = n$$

for  $x$  and take the floor of the positive root, we obtain

$$k_n = \left\lfloor \frac{\sqrt{1 + 8n} - 1}{2} \right\rfloor.$$

From this formula, it is easy to see that  $k_n \leq \sqrt{2n}$ . Since  $r_n \leq k_n$ ,

$$T(n) = (k_n + r_n - 1)2^{k_n} + 1 < 2k_n 2^{k_n} + 1 \leq 2(\sqrt{2n})2^{\sqrt{2n}} + 1 = O(4^{\sqrt{n}}).$$

54. We call a stacking in which the disks are arranged from top to bottom in order from smallest to largest a *proper stacking*. We call a stacking in which the disks in arbitrary order except that the largest disk is on the bottom an *arbitrary stacking*.

Now consider the given problem at the point when the bottom disk first moves. There must be an empty peg for it to move to; thus, the remaining  $n - 1$  disks must be optimally moved to a third peg in an arbitrary stacking. We first determine the minimum number of moves required to move disks from a proper stacking to another peg in an arbitrary stacking.

Our new problem is, given  $n$  disks in a proper stacking, find the minimum number of moves, which we denote  $s_n$ , to move these  $n$  disks to another peg in an arbitrary stacking. Except for the original position, arbitrary stackings are allowed.

Clearly,  $s_1 = 1$ . Suppose  $n > 1$ . Consider the point at which the bottom disk is moved. One peg must be empty (to receive the largest disk), and the  $n - 1$  smaller disks must be moved to a third peg. By definition, this move requires  $s_{n-1}$  moves. Now the largest disk moves (which requires one additional move). Now the  $n - 1$  smaller disks must be placed on top of the largest disk. We can simply peel them off one-by-one and place them on top of the largest disk. This requires  $n - 1$  moves, which is surely optimal. Therefore,

$$s_n = s_{n-1} + 1 + n - 1.$$

Solving, we obtain

$$s_n = 1 + 2 + \cdots + n = \frac{n(n + 1)}{2}.$$

Now we can answer the original question. Consider the point at which the bottom disk first moves. There must be an empty peg for it to move to; thus, the remaining disks must be moved to a third peg, which requires  $n(n + 1)/2$  moves. Now the largest disk moves (which requires one additional move). Finally, the smallest  $n - 1$  disks must be optimally moved and properly stacked on top of the largest disk. This can be done by *reversing* the first  $n(n + 1)/2$  moves. [If there were some way to move the smallest  $n - 1$  disks and properly stack them on top of the

largest disk in fewer than  $n(n+1)/2$ , we could reverse this technique and obtain a method of moving from a proper stacking to an arbitrary stacking in fewer than  $n(n+1)/2$  moves.] Thus optimum number of moves is

$$\frac{n(n+1)}{2} + 1 + \frac{n(n+1)}{2} = n(n+1) + 1.$$

### Section 7.3

2. At line 2, since  $i > j$  ( $1 > 5$ ) is false, we proceed to line 4 where we set  $k$  to 3. At line 5, since  $key$  ( $'P'$ ) is not equal to  $s_3$  ( $'J'$ ), we proceed to line 7. At line 7,  $key < s_k$  ( $'P' < 'J'$ ) is false, so at line 10, we set  $i$  to 4. We then invoke this algorithm with  $i = 4, j = 5$  to search for  $key$  in

$$s_4 = 'M', s_5 = 'X'.$$

At line 2, since  $i > j$  ( $4 > 5$ ) is false, we proceed to line 4 where we set  $k$  to 4. At line 5, since  $key$  ( $'P'$ ) is not equal to  $s_4$  ( $'M'$ ), we proceed to line 7. At line 7,  $key < s_k$  ( $'P' < 'M'$ ) is false, so at line 10, we set  $i$  to 5. We then invoke this algorithm with  $i = j = 5$  to search for  $key$  in

$$s_5 = 'X'.$$

At line 2, since  $i > j$  ( $5 > 5$ ) is false, we proceed to line 4 where we set  $k$  to 5. At line 5, since  $key$  ( $'P'$ ) is not equal to  $s_5$  ( $'X'$ ), we proceed to line 7. At line 7,  $key < s_k$  ( $'P' < 'X'$ ) is true, so at line 8, we set  $j$  to 4. We then invoke this algorithm with  $i = 5, j = 4$  to search for  $key$  in an empty list.

At line 2, since  $i > j$  ( $5 > 4$ ) is true, we return 0 to signal an unsuccessful search.

3. At line 2, since  $i > j$  ( $1 > 5$ ) is false, we proceed to line 4 where we set  $k$  to 3. At line 5, since  $key$  ( $'C'$ ) is not equal to  $s_3$  ( $'J'$ ), we proceed to line 7. At line 7,  $key < s_k$  ( $'C' < 'J'$ ) is true, so at line 8, we set  $j$  to 2. We then invoke this algorithm with  $i = 1, j = 2$  to search for  $key$  in

$$s_1 = 'C', s_2 = 'G'.$$

At line 2, since  $i > j$  ( $1 > 2$ ) is false, we proceed to line 4 where we set  $k$  to 1. At line 5, since  $key$  ( $'C'$ ) is equal to  $s_1$  ( $'C'$ ), we return 1, the index of  $key$  in the sequence  $s$ .

5. We give a proof using induction. We omit the Basis Step.

Assume that  $a_i \leq a_{i+1}$  for all  $i < n$ . We must prove the inequality for  $n$ .

Using (7.3.2) and the inductive assumption, we have

$$a_n = 1 + a_{\lfloor n/2 \rfloor} \leq 1 + a_{\lfloor (n+1)/2 \rfloor} = a_{n+1}.$$

6. We use induction on  $n$ . The Basis Step ( $n = 1$ ) is omitted.

**Inductive Step.** Suppose that  $n > 1$  and  $a_k = \lfloor \lg k \rfloor + 2$  for all  $k < n$ .

If  $n$  is odd,

$$\begin{aligned}
a_n &= 1 + a_{\lfloor n/2 \rfloor} = 1 + a_{(n-1)/2} \\
&= 1 + \lfloor \lg(n-1) \rfloor + 2 && \text{by the inductive assumption} \\
&= 3 + \lfloor \lg(n-1) - 1 \rfloor \\
&= 3 + \lfloor \lg(n-1) \rfloor - 1 && \lfloor x-1 \rfloor = \lfloor x \rfloor - 1 \\
&= 2 + \lfloor \lg(n-1) \rfloor \\
&= 2 + \lfloor \lg n \rfloor && \text{if } j \text{ is odd, } \lfloor \lg j \rfloor = \lfloor \lg(j-1) \rfloor.
\end{aligned}$$

The case when  $n$  is even is treated similarly.

7. (a) We use induction on the size  $n$  of the sequence to prove that *binary\_search2* is correct when the input is a sequence of size  $n$ .

The Basis Step is  $n = 0$ . In this case, the sequence is empty,  $i > j$ , and the algorithm correctly returns 0 to indicate that *key* is not found.

Now assume that if a sequence of length less than  $n$  is input to *binary\_search2*, the algorithm returns the correct value. Suppose that a sequence of length  $n > 0$  is input to *binary\_search2*. Since  $i \leq j$ , the algorithm proceeds to the line where it computes  $k$ . If *key* is at index  $k$ , the algorithm correctly returns  $k$ . If *key* is not at index  $k$ , since the sequence is sorted, *key*, if present, is either in  $s_i, \dots, s_{k-1}$  or  $s_{k+1}, \dots, s_j$ , but not both. The algorithm then executes

$$k1 = \text{binary\_search2}(s, i, k-1, \text{key})$$

If *key* is present in  $s_i, \dots, s_{k-1}$ , by the inductive assumption, *binary\_search2* returns the index where it is located. If *key* is not present in  $s_i, \dots, s_{k-1}$ , by the inductive assumption, *binary\_search2* returns 0. The value returned is stored in  $k1$ . The algorithm then executes

$$k2 = \text{binary\_search2}(s, k+1, j, \text{key})$$

If *key* is present in  $s_{k+1}, \dots, s_j$ , by the inductive assumption, *binary\_search2* returns the index where it is located. If *key* is not present in  $s_{k+1}, \dots, s_j$ , by the inductive assumption, *binary\_search2* returns 0. The value returned is stored in  $k2$ . It follows that if *key* is present in  $s_i, \dots, s_{k-1}$  or  $s_{k+1}, \dots, s_j$ , it is at index  $k1 + k2$ . If *key* is not present in  $s_i, \dots, s_j$ ,  $k1 + k2 = 0$ . Since the algorithm returns  $k1 + k2$ , it follows that the algorithm is correct.

- (b) We define the worst-case time required by the algorithm to be the number of times the algorithm is invoked in the worst case for a sequence containing  $n$  items. Let let  $a_n$  denote the worst-case time.

Suppose that  $n$  is 0, that is,  $i > j$ . In this case, there is one invocation; so  $a_0 = 1$ .

Now suppose that  $n > 1$ . In the worst case, the item will not be found at the line

$$\text{if } (\text{key} == s_k)$$

so the algorithm will be invoked twice more:

$$k1 = \text{binary\_search2}(s, i, k-1, \text{key})$$

$$k2 = \text{binary\_search2}(s, k+1, j, \text{key})$$

By definition, the first invocation will require a total of  $a_{\lfloor (n-1)/2 \rfloor}$  invocations, and the second invocation will require a total of  $a_{\lfloor n/2 \rfloor}$  invocations. Thus we obtain the recurrence relation

$$a_n = 1 + a_{\lfloor (n-1)/2 \rfloor} + a_{\lfloor n/2 \rfloor}.$$

We use strong induction to show that

$$a_n \leq 3n + 1$$

for all  $n \geq 0$ , thus proving that  $a_n = O(n)$ . The Base Case,  $n = 0$ , is readily verified. Now assume that  $n > 0$ . By the inductive assumption,

$$a_{\lfloor (n-1)/2 \rfloor} \leq 3\lfloor (n-1)/2 \rfloor + 1 \quad \text{and} \quad a_{\lfloor n/2 \rfloor} \leq 3\lfloor n/2 \rfloor + 1.$$

Now

$$\begin{aligned} a_n &= 1 + a_{\lfloor (n-1)/2 \rfloor} + a_{\lfloor n/2 \rfloor} \\ &\leq 1 + 3\lfloor (n-1)/2 \rfloor + 1 + 3\lfloor n/2 \rfloor + 1 \\ &= 3 + 3(\lfloor (n-1)/2 \rfloor + \lfloor n/2 \rfloor) \\ &= 3 + 3(n-1) = 3n < 3n + 1. \end{aligned}$$

We conclude by using strong induction to show that

$$a_n \geq n$$

for all  $n \geq 0$ , thus proving that  $a_n = \Omega(n)$  and, therefore,  $a_n = \Theta(n)$ . The Base Case,  $n = 0$ , is readily verified. Now assume that  $n > 0$ . By the inductive assumption,

$$a_{\lfloor (n-1)/2 \rfloor} \geq \lfloor (n-1)/2 \rfloor \quad \text{and} \quad a_{\lfloor n/2 \rfloor} \geq \lfloor n/2 \rfloor.$$

Now

$$\begin{aligned} a_n &= 1 + a_{\lfloor (n-1)/2 \rfloor} + a_{\lfloor n/2 \rfloor} \\ &\geq 1 + \lfloor (n-1)/2 \rfloor + \lfloor n/2 \rfloor \\ &= 1 + (n-1) = n. \end{aligned}$$

9.

|                                |                                |   |
|--------------------------------|--------------------------------|---|
| 1                              | 1                              | 1 |
| 9                              | 9                              | 3 |
| 7                              | 3                              | 7 |
| 3                              | 7                              | 9 |
| Merge<br>one-element<br>arrays | Merge<br>two-element<br>arrays |   |



12. We give a recursive description. We assume that the input consists of the integers from 1 to  $n$ . Let  $m = \lfloor (n+1)/2 \rfloor$ .

Set

$$s_1 = 1, s_2 = 3, s_3 = 5, \dots, s_m = 2m - 1$$

and

$$s_{m+1} = 2, s_{m+2} = 4, \dots, s_n = 2\lfloor n/2 \rfloor.$$

Now arrange  $s_1, \dots, s_m$  to produce worst-case behavior for *merge\_sort* and arrange  $s_{m+1}, \dots, s_n$  to produce worst-case behavior for *merge\_sort*.

13. Seven, which occurs for an already sorted array.
15. **Basis Step.**  $a_1 = 0 < 2 = 2a_1 + 2 = a_2$ .

**Inductive Step.** Assume that the inequality holds for  $k < n$ . Now

$$\begin{aligned} a_{n+1} &= a_{\lfloor (n+1)/2 \rfloor} + a_{\lfloor (n+2)/2 \rfloor} + n \\ &\geq a_{\lfloor n/2 \rfloor} + a_{\lfloor (n+1)/2 \rfloor} + n - 1 = a_n. \end{aligned}$$

16. The last inequality in the proof of Theorem 7.3.10 gives  $a_n \leq 2n \lg n + 2n + 1$  for all  $n$ . If  $3 \leq \lg n$  (or, equivalently, if  $8 \leq n$ ),  $2n + 1 \leq 3n \leq n \lg n$ . Therefore if  $8 \leq n$ ,

$$a_n \leq 2n \lg n + 2n + 1 \leq 3n \lg n.$$

The cases  $1 \leq n < 7$  can be checked directly.

17. Sequences of length  $m$  and  $n$ , where  $m \leq n$ , require, at the minimum,  $m - 1$  comparisons for merging. Thus if  $b_n$  denotes the least number of comparisons used by mergesort,  $b_n$  satisfies

$$b_n = b_{\lfloor n/2 \rfloor} + b_{\lfloor (n+1)/2 \rfloor} + \left\lfloor \frac{n}{2} \right\rfloor - 1.$$

This recurrence relation can be estimated in the same way as the one for the worst-case time; therefore, the best-case time is  $\Theta(n \lg n)$ .

23. If  $n = 1$ ,  $a^n = a$ ; thus,  $a$  is returned. For  $n > 1$ , if  $n$  is even,  $m = \lfloor n/2 \rfloor = n/2$  and  $a^n = a^m a^m$ . If  $n$  is odd,  $m = (n-1)/2$  and  $a^n = a^m a^m a$ .
24. If  $n$  is odd,  $m = (n-1)/2$ . If  $n > 1$ , after  $a^m$  is computed in line 5, line 6 is executed to compute  $a^m a^m$  and line 10 is then executed to compute  $a^m a^m a$ . Thus  $b_n = b_{(n-1)/2} + 2$ . If  $n$  is even,  $m = n/2$  and line 6 is executed to compute  $a^m a^m$ . In this case, line 10 is not executed, so  $b_n = b_{n/2} + 1$ .
25.  $b_1 = 0$ ,  $b_2 = 1$ ,  $b_3 = 2$ ,  $b_4 = 2$
26. Assume that  $n = 2^k$ . Now

$$b_n = b_{2^{k-1}} + 1 = b_{2^{k-2}} + 2 = \dots = b_1 + k = 0 + k = \lg n.$$

27.  $b_7 = 4$ ,  $b_8 = 3$

28. We use induction on  $n$  to prove that

$$\lg n \leq b_n \leq 2 \lg n,$$

from which we deduce  $b_n = \Theta(\lg n)$ . The Basis Step ( $n = 1$ ) is omitted.

Assume that  $n > 1$ . If  $n$  is even, we have

$$b_n = b_{n/2} + 1 \leq 1 + 2 \lg \frac{n}{2} = 1 + 2[(\lg n) - 1] \leq 2 \lg n$$

and

$$b_n = b_{n/2} + 1 \geq 1 + \lg \frac{n}{2} = 1 + (\lg n) - 1 = \lg n.$$

If  $n$  is odd, we have

$$b_n = b_{(n-1)/2} + 2 \leq 2 + 2 \lg \frac{n-1}{2} = 2 + [2 \lg(n-1)] - 2 \leq 2 \lg n$$

and

$$b_n = b_{(n-1)/2} + 2 \geq 2 + \lg \frac{n-1}{2} = 2 + [\lg(n-1)] - 1 = 1 + \lg(n-1) \geq \lg n.$$

The last inequality is equivalent to

$$1 \geq \lg \frac{n}{n-1}$$

or

$$2 \geq \frac{n}{n-1}$$

which is easily seen to be true for  $n > 1$ .

29. If  $i = j$ , there is only one element in the array, which is both largest and smallest. In this case, the algorithm simply returns these values.

If  $i < j$ , the algorithm divides the array into two nearly equal parts at line 7. At lines 8 and 9, the algorithm recursively finds that largest and smallest elements in each of the parts. The overall largest element is the larger of the largest in each of the parts (computed at line 11 or 13), and the overall smallest element is the smaller of the smallest in each of the parts (computed at line 15 or 17).

30. For input of size 1,  $i = j$ ; no comparisons are made since the algorithm returns at line 5. Thus  $b_1 = 0$ .

For input of size 2, no comparisons are made during the recursive calls at lines 8 and 9 (since each involves input of size 1). There is one comparison at line 10 and one at line 14. Thus  $b_2 = 2$ .

31. 4

32. At lines 8 and 9,  $a_{\lfloor n/2 \rfloor} + a_{\lfloor (n+1)/2 \rfloor}$  comparisons are made. At lines 10 and 14, two comparisons are made.

33. If  $n = 2^k$ , the recurrence relation becomes  $b_{2^k} = 2b_{2^{k-1}} + 2$ . Now

$$\begin{aligned} b_n &= b_{2^k} = 2b_{2^{k-1}} + 2 = 2[2b_{2^{k-2}} + 2] + 2 \\ &= 2^2b_{2^{k-2}} + 2^2 + 2 = \dots \\ &= 2^k b_{2^0} + 2^k + 2^{k-1} + \dots + 2 \\ &= 2^k + 2^{k-1} + \dots + 2 = 2^{k+1} - 2 = 2 \cdot 2^k - 2 = 2n - 2 \end{aligned}$$

34. We give only the Inductive Step.

Assume that  $b_k = 2k - 2$ , for  $k < n$ . The inductive assumption gives

$$\begin{aligned} b_{\lfloor n/2 \rfloor} &= 2\lfloor n/2 \rfloor - 2 \\ b_{\lfloor (n+1)/2 \rfloor} &= 2\lfloor (n+1)/2 \rfloor - 2. \end{aligned}$$

If  $n$  is even,  $\lfloor n/2 \rfloor = n/2 = \lfloor (n+1)/2 \rfloor$ , so

$$b_n = 2[2(n/2) - 2] + 2 = 2n - 2.$$

If  $n$  is odd,  $\lfloor n/2 \rfloor = (n-1)/2$  and  $\lfloor (n+1)/2 \rfloor = (n+1)/2$ , so

$$b_n = [2(n-1)/2 - 2] + [2(n+1)/2 - 2] + 2 = 2n - 2.$$

40. If  $n = 1$ , there is nothing to sort so the algorithm simply returns. If  $n > 1$ , the elements  $s_1, \dots, s_{n-1}$  are sorted as a result of the recursive call. To sort the entire array, the  $n$ th element  $s_n$ , stored in the variable *temp*, is compared to each of the preceding elements which are moved up one position successively as long as they are greater than *temp*. The index  $i$  runs down the list. As soon as an element less than or equal to *temp* is found (pointed to by  $i$ ), the loop is exited and *temp* is stored at position  $i + 1$ . If there is no element less than or equal to *temp*,  $i$  is 0 and *temp* is stored at position 1.

41. The worst-case behavior occurs when the items are in reverse order.

$$42. b_1 = 0, b_2 = 1, b_3 = 3 \qquad 43. b_n = b_{n-1} + n - 1 \qquad 44. b_n = \frac{n(n-1)}{2}$$

$$45. b_n = 1 + \lfloor \lg n \rfloor + b_{\lfloor n/2 \rfloor}, b_1 = 1, b_2 = 3, b_3 = 3 \qquad 46. b_n = (1 + \lg n)(2 + \lg n)/2$$

47. An arbitrary value of  $n$  falls between two powers of 2, say

$$2^{k-1} < n \leq 2^k.$$

This inequality implies that  $k - 1 < \lg n \leq k$ . Since the sequence  $b$  is nondecreasing,

$$b_{2^{k-1}} \leq b_n \leq b_{2^k}.$$

Now

$$b_n \leq b_{2^k} = \frac{(1+k)(2+k)}{2} \leq \frac{(2+\lg n)(3+\lg n)}{2} = O((\lg n)^2).$$

Similarly,  $b_n = \Omega((\lg n)^2)$ . Therefore  $b_n = \Theta((\lg n)^2)$ .

50.  $b_1 = 1, b_2 = 2, b_3 = 3,$       51.  $b_n = b_{n-1} + 1$       52.  $b_n = n$       53.  $\Theta(n)$

55. Similar to the proof for Exercise 47      57.  $b_n = b_{\lfloor (1+n)/2 \rfloor} + b_{\lfloor n/2 \rfloor} + n$

58. Let  $c_k = b_{2^k}$ . Then  $c_k = 2c_{k-1} + 3$ . If  $n = 2^k$ ,

$$\begin{aligned} b_n &= c_k = 2c_{k-1} + 3 = 2(2c_{k-2} + 3) + 3 = \cdots \\ &= 2^k c_0 + 3(2^{k-1} + 2^{k-2} + \cdots + 1) = 2^k \cdot 0 + 3(2^k - 1) \\ &= 3(n - 1). \end{aligned}$$

60. Use the method of Exercise 58.      61.  $b_n = n(1 + \lg n)$

63. Use Exercise 60 to show that if  $n$  is a power of 2,  $b_n = n \lg n$ . Now let  $n$  be arbitrary. Choose  $k$  so that  $2^k < n \leq 2^{k+1}$ . By Exercise 62,  $b_n \leq b_{2^{k+1}}$ . Now

$$b_{2^{k+1}} = 2^{k+1}(k+1) \leq 2^{k+1}(k+k) = 4(2^k k) \leq 4n \lg n.$$

65.  $a_n \leq a_{\lfloor n/2 \rfloor} + a_{\lfloor (n+1)/2 \rfloor} + 2 + \lg(\lfloor n/2 \rfloor \lfloor (n+1)/2 \rfloor)$ . If  $n$  is even,  $\lfloor n/2 \rfloor \lfloor (n+1)/2 \rfloor = n^2/4$ . If  $n$  is odd,  $\lfloor n/2 \rfloor \lfloor (n+1)/2 \rfloor = \lfloor (n-1)/2 \rfloor \lfloor (n+1)/2 \rfloor = (n^2 - 1)/4 \leq n^2/4$ . Thus we can write

$$a_n \leq a_{\lfloor n/2 \rfloor} + a_{\lfloor (n+1)/2 \rfloor} + 2 + \lg \frac{n^2}{4} = a_{\lfloor n/2 \rfloor} + a_{\lfloor (n+1)/2 \rfloor} + 2 \lg n.$$

66. Let  $n = 2^k$  and use induction on  $k$ .

**Basis Step.** If  $k = 0$ ,  $b_1 = 0 = 4 \cdot 1 - 2 \lg 1 - 4$

**Inductive Step.**

$$\begin{aligned} b_{2^{k+1}} &= 2b_{2^k} + 2(k+1) = 2[4 \cdot 2^k - 2k - 4] + 2(k+1) \\ &= 4 \cdot 2^{k+1} - 2(k+1) - 4 \end{aligned}$$

68. **Inductive Step.**

$$b_n = b_{\lfloor n/2 \rfloor} + b_{\lfloor (n+1)/2 \rfloor} + 2 \lg n \leq b_{\lfloor (n+1)/2 \rfloor} + b_{\lfloor (n+2)/2 \rfloor} + 2 \lg(n+1) = b_{n+1}$$

69. Choose  $k$  with  $2^k < n \leq 2^{k+1}$ . Then

$$a_n \leq b_n \leq b_{2^{k+1}} = 4 \cdot 2^{k+1} - 2(k+1) - 4 \leq 8 \cdot 2^k \leq 8n.$$

# Chapter 8

## Solutions to Selected Exercises

### Section 8.1

2. The following undirected graph models the tournament:

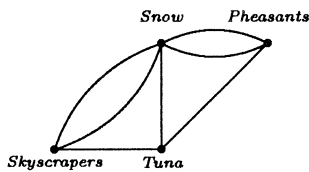

3. The following simple, directed graph models the tournament:

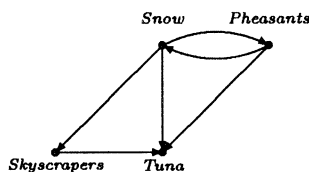

6. There are vertices of odd degree  $\{b, d\}$ .
7. There are vertices of odd degree  $\{b, d\}$ .
9.  $(a, c, f, e, c, b, e, d, b, a)$
10.  $(a, b, c, e, b, d, e, f, c, g, h, i, f, h, e, g, d, a)$
12.  $V = \{v_1, v_2, v_3, v_4, v_5\}$ .  $E = \{e_1, e_2, e_3, e_4, e_5, e_6, e_7, e_8\}$ . There are no parallel edges, no loops, and no isolated vertices.  $G$  is simple.  $e_1$  is incident on  $v_2$  and  $v_4$ .
13.  $V = \{v_1, v_2, v_3\}$ .  $E$  is empty. There are no parallel edges and no loops.  $G$  is simple.  $e_1$  does not exist. All vertices are isolated.
15.  $n(n - 1)/2$

16.  $V_1 = \{v_1, v_2, v_3, v_4\}$ ,  $V_2 = \{v_5, v_6, v_7\}$ .

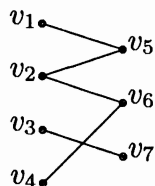

18. The graph is bipartite.  $V_1 = \{v_1, v_3, v_4, v_6, v_8, v_9, v_{10}\}$ ,  $V_2 = \{v_2, v_5, v_7\}$ .
19. The graph is bipartite.  $V_1 = \{Gre, Buf, Sho, Dou, Mud\}$ ,  $V_2 = \{She, Wor, Cas, Gil, Lan\}$ .
21. Not bipartite                      22. Not bipartite                      25.  $mn$
26. Example 8.1.12 is bipartite, but Examples 8.1.13 and 8.1.14 are not bipartite.  $K_1$  is not bipartite because there is no way to partition the vertices into two *nonempty* subsets.
28.  $(c, a, b, e, d)$                       29.  $(a, c, d, e, b)$
30. The vertices are mathematicians, and an edge connects two mathematicians if they co-authored a paper. The Erdős number of mathematician  $m$  is the length of a shortest path from  $m$  to Erdős.
31. Yes
33. One class.

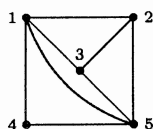

34. No. If similarity is defined solely by the dissimilarity function, in the graph of Figure 8.1.8,  $v_1$  is similar to  $v_3$  and  $v_3$  is similar to  $v_5$ , but  $v_1$  is not similar to  $v_5$ .

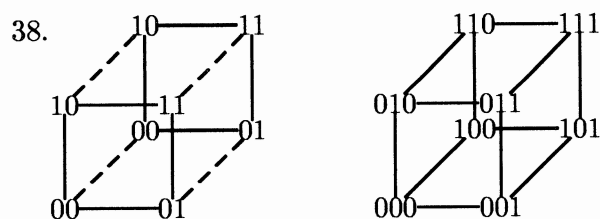

41.  $n2^{n-1}$  (There are  $2^n$  vertices and each is incident on  $n$  edges. Since  $n2^n$  counts each edge twice, the formula follows.)
42.  $n!2^n$  (The result can be proved by induction on  $n$ .)

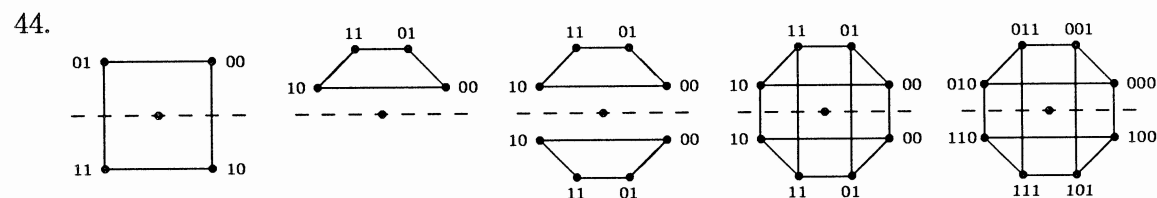

47. 5

48.

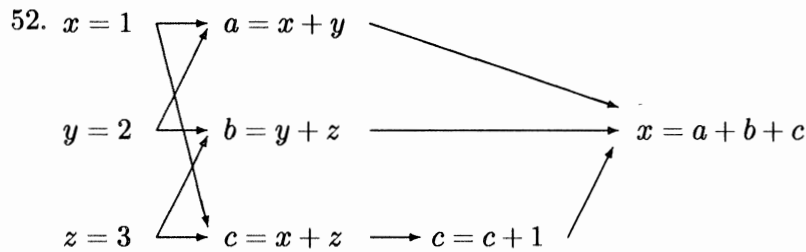
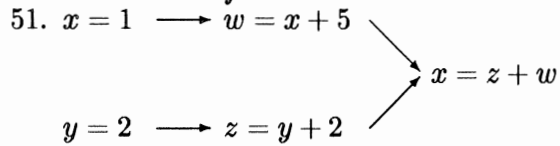
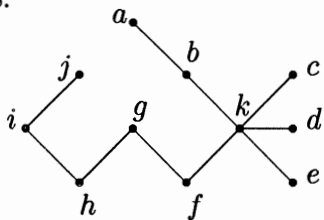

**Section 8.2**

- 2. Simple path—yes; cycle—no; simple cycle—no
- 3. Simple path—no; cycle—no; simple cycle—no
- 5. Simple path—no; cycle—no; simple cycle—no
- 6. Simple path—no; cycle—yes; simple cycle—no
- 8. Simple path—yes; cycle—no; simple cycle—no
- 9. Simple path—yes; cycle—no; simple cycle—no

11. There is no such graph since there are always an even number of vertices of odd degree.

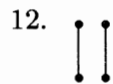

14. No such graph exists. One-half the sum of the degrees (= number of edges) is 5, not 4.

15.

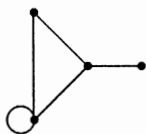

17.

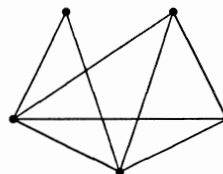

18. No such graph exists. Suppose, by way of contradiction, that there is such a graph with vertices  $a$  and  $b$  of degree 2 and  $c, d,$  and  $e$  of degree 4. Since  $c$  is of degree 4, it is incident on  $a, b, d,$  and  $e$ . Similarly,  $d$  is incident on  $a, b, c,$  and  $e$ , and  $e$  is incident on  $a, b, c,$  and  $d$ . But now  $a$  has degree at least 3. Contradiction.
20.  $(a, b, c, d, e), (a, b, c, d, f, e), (a, b, c, g, f, e), (a, b, c, g, f, d, e), (a, b, g, f, e), (a, b, g, c, d, e), (a, b, g, f, d, e), (a, b, g, c, d, f, e)$

21.

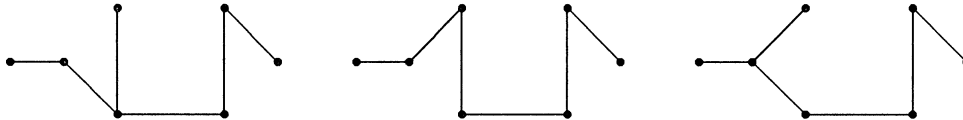

The second is a simple path. Neither is a cycle or a simple cycle.

23.  $\delta(v_1) = 2, \delta(v_2) = 2, \delta(v_3) = 3, \delta(v_4) = 6, \delta(v_5) = 2, \delta(v_6) = 3, \delta(v_7) = 4, \delta(v_8) = 4, \delta(v_9) = 4, \delta(v_{10}) = 2$
25. There are six subgraphs, the following five subgraphs and the original graph itself.



26. The following are the subgraphs with no edges:  $G_1 = (\{v_1\}, \emptyset), G_2 = (\{v_2\}, \emptyset), G_3 = (\{v_3\}, \emptyset), G_4 = (\{v_1, v_2\}, \emptyset), G_5 = (\{v_1, v_3\}, \emptyset), G_6 = (\{v_2, v_3\}, \emptyset), G_7 = (\{v_1, v_2, v_3\}, \emptyset)$ . The other subgraphs are

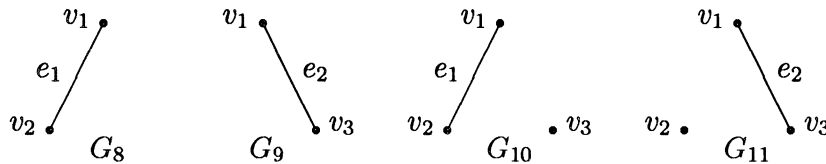

and  $G$  itself.

29.  $(v_1, v_5, v_2, v_4, v_5, v_3, v_2, v_1, v_4, v_3, v_1)$
30. There is no Euler cycle since there are vertices of odd degree.
32.  $(a, b, d, c, b, f, g, j, f, e, j, h, c, i, d, e, i, h, a)$
33.  $(a, b, c, b, d, e, h, f, i, j, k, i, h, g, f, e, g, d, c, a)$
35. When  $n$  is odd
36. Both  $m$  and  $n$  must be even.
38. When  $n$  is even
40. There are zero vertices of even degree, and zero is even.
41.  $(d, a, b, d, e, b, c, e, h, g, d, f, g, j, h, i, e)$



43.  $(b, c, d, g, b, a, f, g, i, f); (c, h, e)$

44. Let  $G$  be a connected graph with  $n$  vertices  $v_1, \dots, v_n$  of odd degree. There are paths with no repeated edges from  $v_1$  to  $v_2$ ,  $v_3$  to  $v_4$ , and so on, such that every edge in  $G$  is in exactly one of the paths.

46. False. Consider the cycle  $(a, b, c, a)$  for the graph

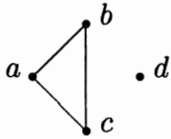

48. The graph of Exercise 26

49. No. Let the vertices of a graph be the squares of the chessboard. Insert an edge between two vertices if a knight can make a move between the corresponding squares. The degrees of the vertices that correspond to the border squares next to the corner squares have degree 3. Since there are eight of these, there is no Euler cycle.

51. Let  $H$  be one of the connected subgraphs in the partition. Let  $v$  be a vertex in  $H$ . Let  $C$  be the component to which  $v$  belongs. We show that  $H = C$ .

Let  $w$  be a vertex in  $H$ . Since  $H$  is connected, there is a path from  $v$  to  $w$  in  $H$ . Therefore  $w$  is in  $C$ .

Let  $w$  be a vertex in  $C$ . Then there is a path from  $v$  to  $w$

$$(v_0, v_1, \dots, v_n),$$

with  $v_0 = v$ ,  $v_n = w$ , in  $C$ . The edge  $(v_0, v_1)$  must belong to  $H$  since vertex  $v_0$  is in  $H$ . Thus vertex  $v_1$  is in  $H$ . Continuing in this way, we see that  $w$  is in  $H$ . Therefore the vertex sets of  $H$  and  $C$  are equal.

Similarly, the edges sets of  $H$  and  $C$  are equal. Therefore the subgraphs of the partition are components.

52. There is a path  $P$  from  $v$  to  $w$ . Change the orientation of each edge in  $P$ .

54. Let  $G$  be a simple, bipartite graph having the maximum number of edges with disjoint vertex sets having  $k$  and  $n - k$  vertices. Then  $G$  has  $k(n - k)$  edges. The maximum of the integer-valued function  $f(k) = k(n - k)$  occurs when  $k = n/2$ , if  $n$  is even, and when  $k = (n - 1)/2$  or  $k = (n + 1)/2$ , if  $n$  is odd. Thus the maximum number of edges is  $\lfloor n^2/4 \rfloor = n^2/4$ , if  $n$  is even, and  $\lfloor n^2/4 \rfloor = [(n - 1)/2][(n + 1)/2]$ , if  $n$  is odd.

56.  $K_6$

60. If

$$(b_1^{(1)}b_2^{(1)} \dots b_{n-1}^{(1)}, b_1^{(2)}b_2^{(2)} \dots b_{n-1}^{(2)}, \dots)$$

is a directed Euler cycle in  $G$ ,

$$b_1^{(1)}b_2^{(1)} \dots b_{n-1}^{(1)}b_{n-1}^{(2)}b_{n-1}^{(3)} \dots$$

is a de Bruijn sequence.

62. We first show that if  $G$  is a connected bipartite graph, then every closed path in  $G$  has even length.

Suppose that the disjoint vertex sets are  $V_1$  and  $V_2$ . Let

$$P = (v_0, v_1, \dots, v_n)$$

be a closed path from  $v_0$  to  $v_n$ . Suppose that  $v_0 \in V_1$ . Then  $v_1 \in V_2$ ,  $v_2 \in V_1, \dots$ . Notice that if  $i$  is odd,  $v_i \in V_2$ , and if  $i$  is even,  $v_i \in V_1$ . Since  $v_n \in V_1$ , it follows that  $n$  is even. Thus  $P$  has even length.

We conclude by showing that if every closed path in a connected graph  $G$  has even length, then  $G$  is bipartite.

Choose a vertex  $v$  in  $G$ . Let  $V_1$  denote the set of vertices  $w$  in  $G$  that are reachable from  $v$  on a path of even length. Let  $V_2$  denote the set of vertices  $w$  in  $G$  that are reachable from  $v$  on a path of odd length. Notice that since  $G$  is connected, every vertex in  $G$  is either in  $V_1$  or  $V_2$ . We claim that  $V_1$  and  $V_2$  are disjoint. To show this, we argue by contradiction. Suppose that some vertex  $w$  belongs to both  $V_1$  and  $V_2$ . Then there is a path  $P'_o$  of odd length and a path  $P_e$  of even length from  $v$  to  $w$ . Let  $P_o$  be the path from  $w$  to  $v$  obtained by reversing the order of the vertices. Then  $P_e$  followed by  $P_o$  is a closed path of odd length from  $v$  to  $v$ . This contradiction shows that  $V_1$  and  $V_2$  are disjoint. Now let  $e$  be an edge incident on vertices  $x$  and  $y$ . Suppose that  $x$  belongs to  $V_1$ . Then there is a path  $P$  of even length from  $v$  to  $x$ . Now  $P$  followed by  $y$  is a path of odd length from  $v$  to  $y$ . Thus  $y$  is in  $V_2$ . Therefore  $G$  is bipartite.

63.  $n(n-1)^k$  [Choose  $(v_0, v_1, \dots, v_k)$  with  $v_{i-1} \neq v_i$ .]
65. (a)  $p_m = (n-1)^{m-1} - p_{m-1}$ . The first term counts the number of paths of length  $m-1$  that start with  $v$ , and the last term counts the number of paths of length  $m-1$  that start with  $v$  and end with  $w$ . A path of length  $m-1$  that starts with  $v$  and does not end with  $w$  can be extended to a path of length  $m$  that starts with  $v$  and ends with  $w$ .
- (b)

$$\begin{aligned} p_m &= (n-1)^{m-1} - [(n-1)^{m-2} - p_{m-2}] \\ &= (n-1)^{m-1} - (n-1)^{m-2} + p_{m-2} \\ &\quad \vdots \\ &= (n-1)^{m-1} - (n-1)^{m-2} + \dots + (-1)^m(n-1) + (-1)^{m+1}p_1 \\ &= (n-1)^{m-1} - (n-1)^{m-2} + \dots + (-1)^m(n-1) + (-1)^{m+1} \\ &= \frac{-(n-1)^m - (-1)^{m+1}}{-(n-1) - 1} \\ &= \frac{(n-1)^m + (-1)^{m+1}}{n} \end{aligned}$$

66. There is one path of length 1,  $(v, w)$ , from  $v$  to  $w$ .

There are  $n-2$  paths of length 2,  $(v, x_1, w)$ , from  $v$  to  $w$  since vertex  $x_1$  can be chosen in  $n-2$  ways. (Vertex  $x_1$  must be different from  $v$  and  $w$ .)

There are  $(n-2)(n-3)$  paths of length 3,  $(v, x_1, x_2, w)$ , from  $v$  to  $w$  since vertex  $x_1$  can be chosen in  $n-2$  ways, and vertex  $x_2$  can be chosen in  $n-3$  ways. (Vertex  $x_1$  must be different from  $v$  and  $w$ , and vertex  $x_2$  must be different from  $v$ ,  $w$ , and  $x_1$ .)

In general, there are  $(n-2)(n-3)\cdots(n-k)$  paths of length  $k$ ,  $(v, x_1, \dots, x_{k-1}, w)$ , from  $v$  to  $w$  since vertex  $x_1$  can be chosen in  $n-2$  ways, vertex  $x_2$  can be chosen in  $n-3$  ways, and so on. The result now follows.

67. The number of simple paths of length 0 is  $n$ ; the number of simple paths of length 1 is  $n(n-1)$ ; the number of simple paths of length 2 is  $n(n-1)(n-2)$ ; and so on. Thus the number of simple paths is

$$n + n(n-1) + n(n-1)(n-2) + \cdots + n(n-1)\cdots 1 = n! \sum_{k=0}^{n-1} \frac{1}{k!}.$$

Now

$$\begin{aligned} n! \sum_{k=0}^{n-1} \frac{1}{k!} &= n! \left( e - \sum_{k=n}^{\infty} \frac{1}{k!} \right) \\ &= n!e - 1 - n! \sum_{k=n+1}^{\infty} \frac{1}{k!}. \end{aligned}$$

Since, for  $n \geq 2$ ,

$$\begin{aligned} n! \sum_{k=n+1}^{\infty} \frac{1}{k!} &= \frac{1}{n+1} + \frac{1}{(n+1)(n+2)} + \cdots \\ &< \frac{1}{n} + \frac{1}{n^2} + \cdots = \frac{\frac{1}{n}}{1 - \frac{1}{n}} = \frac{1}{n-1} \leq 1, \end{aligned}$$

the result follows. The result is true by inspection for  $n = 1$ .

69. A connected graph with one vertex, consists of the vertex, say  $v$ , and none or more loops incident on  $v$ . An Euler cycle consists of a cycle that traverses each loop once.

A connected graph with two vertices, say  $v$  and  $w$ , each of which has even degree, consists of  $2k$  edges incident on  $v$  and  $w$ ,  $k \geq 1$ , none or more loops incident on  $v$ , and none or more loops incident on  $w$ . An Euler cycle consists of a path that begins at  $v$ , traverses all of the loops incident on  $v$ , traverses one edge from  $v$  to  $w$ , traverses all of the loops incident on  $w$ , traverses one edge from  $w$  to  $v$ , and traverses all remaining edges incident on  $v$  and  $w$ . This path will end at  $v$  since there are an even number of edges incident on  $v$  and  $w$ .

71. diameter =  $n$ . The diameter is the maximum time for two processors to communicate.

72. 1, since  $\text{dist}(v, w) = 1$  for every pair of distinct vertices in  $K_n$

74. First we show that, if  $n \bmod 4 = 1$ ,

$$k \geq \frac{n-1}{2}.$$

Suppose that  $n \bmod 4 = 1$ . In particular,  $n$  is odd. Since every vertex has degree  $k$ ,  $k$  must be even. (If  $k$  is odd, we obtain a contradiction to the theorem that states that there are an even number of vertices of odd degree). We show that  $(n-3)/2$  is an odd integer and, consequently,

$$k \geq \frac{n-3}{2} + 1 = \frac{n-1}{2}.$$

Since  $n \bmod 4 = 1$ , we may write  $n = 4q + 1$ . Thus  $n - 3 = 4q - 2$  and  $(n - 3)/2 = 2q - 1$ , which is an odd integer. Therefore

$$k \geq \frac{n-1}{2},$$

regardless of the value of  $n \bmod 4$ .

Now suppose that  $G$  is not connected. Let  $C_1$  and  $C_2$  be components. Since every vertex has degree  $k$ ,  $C_1$  and  $C_2$  each have at least  $k + 1$  vertices. Thus  $G$  has at least  $2(k + 1) \geq n + 1$  vertices, which is a contradiction.

76. We prove the result by induction on  $n$ . We omit the Basis Step ( $n = 1$ ).

Assume that the result is true for  $n$ . Let  $G$  be an  $(n+1)$ -vertex dag with the maximum number of edges. By Exercise 74,  $G$  has a vertex  $v$  with no out edges. In fact, there must be edges of the form  $(w, v)$  for all  $w \neq v$ ; otherwise,  $G$  would not have the maximum number of edges. This accounts for  $n$  edges.

Let  $G'$  be the graph obtained from  $G$  by eliminating  $v$  and the  $n$  edges incident on  $v$ .  $G'$  is an  $n$ -vertex dag and since  $G$  has the maximum number of vertices,  $G'$  must also have the maximum number of vertices. By the inductive assumption,  $G'$  has  $n(n-1)/2$  vertices. Thus  $G$  has

$$\frac{n(n-1)}{2} + n = \frac{(n+1)n}{2}$$

vertices.

77. Let  $I(P_n)$  denote the number of independent sets in  $P_n$ . Note that  $I(P_1) = 2$  and  $I(P_2) = 3$ . Now suppose that  $n > 2$ . Let  $v$  be a vertex of degree 1 in  $P_n$ . An independent set  $P_n$  that contains  $v$  consists of  $v$  and an independent set of  $P_{n-2}$ , and there are  $I(P_{n-2})$  such independent sets. An independent set of  $P_n$  that does not contain  $v$  is an independent set of  $P_{n-1}$ , and there are  $I(P_{n-1})$  such independent sets. Therefore

$$I(P_n) = I(P_{n-1}) + I(P_{n-2}).$$

Since  $\{I(P_n)\}$  satisfies the same initial conditions and recurrence relation as  $\{f_{n+2}\}$ ,  $I(P_n) = f_{n+2}$  for all  $n$ .

78. (a) Let  $v$  and  $w$  be nonadjacent vertices in  $G$ . Let

$$\{x_1, \dots, x_k\}$$

denote the vertices adjacent to  $v$ . Then the mapping  $N(x_i) = y_i$ , where  $y_i$  is adjacent to  $x_i$  and  $w$ , is a bijection to the set of vertices adjacent to  $w$ . Therefore  $\delta(v) = \delta(w)$ .

- (b) Let  $V_1$  denote the set of vertices of degree  $k$ . Suppose that  $\overline{V_1}$  is nonempty. By part (a), every vertex in  $V_1$  is adjacent to every vertex in  $\overline{V_1}$ . Since no vertex is adjacent to all other vertices,  $|V_1| \leq 2$  and  $|\overline{V_1}| \leq 2$ . Let  $v_1$  and  $w_1$  be distinct vertices in  $V_1$ , and let  $v_2$  and  $w_2$  be distinct vertices in  $\overline{V_1}$ . Now  $v_1$  adjacent to  $v_2$  and  $w_2$  and  $w_1$  adjacent to  $v_2$  and  $w_2$ , which is a contradiction since there are two vertices ( $v_2$  and  $w_2$ ) adjacent to both  $v_1$  and  $w_1$ .

### Section 8.3

2.  $(a, b, c, d, e, f, n, p, m, l, k, j, o, i, h, g, a)$
4. We would have to eliminate one edge at  $f$ , three edges at  $c$ , one edge at  $b$ , one edge at  $i$ , three edges at  $j$ , and three edges at  $m$ , leaving 15 edges. Since there are 16 vertices, a Hamiltonian cycle would have 16 edges.
5. Suppose that the graph has a Hamiltonian cycle. Since each vertex in a cycle has degree 2, we would have to include the edges  $(a, b)$ ,  $(a, f)$ ,  $(f, g)$ ,  $(b, c)$ ,  $(c, d)$ ,  $(d, e)$ ,  $(e, h)$ , and  $(g, h)$ . Since these edges already form a cycle, there is no Hamiltonian cycle.
7.  $(a, b, c, g, l, m, r, q, p, k, j, f, e, i, n, o, t, s, h, d, a)$
8. There is no Hamiltonian cycle. We would have to eliminate two edges at  $c$ , three edges at  $e$ , and one edge at  $f$ , leaving six edges. Since there are seven vertices, a Hamiltonian cycle would have seven edges.

10.  $K_3$

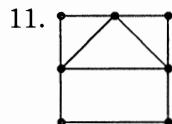

13. We begin the Hamiltonian cycle at row 1, column 1 and proceed along the first row to column  $m - 1$ . Then we go down to row 2 and move back along row 2 to column 1. Then we go down to row 3 and along row 3 to column  $m - 1$ . Then we go down to row 4 and back to column 1 along row 4. We continue this serpentine path until we arrive at the last row. If  $n$  is odd, we finish in column 1. We then take the edge from row  $n$ , column 1 to row  $n$ , column  $m$  and proceed up column  $m$  to row 1. We then follow the edge from row 1, column  $m$  to row 1, column 1 finishing the cycle. If  $n$  is even, we ended our path at row  $n$ , column  $m - 1$ . We then move along row  $n$  to column  $m$ , up column  $m$  to row 1, and along the edge from row 1, column  $m$  to row 1, column 1 to finish the cycle.
14. Choose any vertex  $v$  to start. After arriving at a vertex, move to a not-yet-visited vertex (except when returning to  $v$  for the  $n$ th and last move). Since the degree of every vertex is  $n - 1$  and there are  $n$  moves, such moves are always possible.
16. The five edges of smallest weight have weights 3, 4, 4, 5, 5. Thus the shortest Hamiltonian cycle has a weight of at least 21. However, three of these edges (those with weights 3, 4, 4) are incident on vertex  $c$ . Thus the edges of weight 3, 4, 4 cannot all be in a Hamiltonian cycle. If

we replace an edge of weight 4 with an edge of minimum replacement weight 6, we can conclude that the shortest Hamiltonian cycle has weight at least

$$3 + 6 + 4 + 5 + 5 = 23.$$

Since the given Hamiltonian cycle has weight 23, we conclude that it is minimal.

17.  $(e, d, a, b, c, e)$

19.

|           |                                                                                    |
|-----------|------------------------------------------------------------------------------------|
| $G_1$ :   | 0 1                                                                                |
| $G_1^R$ : | 1 0                                                                                |
| $G_1'$ :  | 00 01                                                                              |
| $G_1''$ : | 11 10                                                                              |
| $G_2$ :   | 00 01 11 10                                                                        |
| $G_2^R$ : | 10 11 01 00                                                                        |
| $G_2'$ :  | 000 001 011 010                                                                    |
| $G_2''$ : | 110 111 101 100                                                                    |
| $G_3$ :   | 000 001 011 010 110 111 101 100                                                    |
| $G_3^R$ : | 100 101 111 110 010 011 001 000                                                    |
| $G_3'$ :  | 0000 0001 0011 0010 0110 0111 0101 0100                                            |
| $G_3''$ : | 1100 1101 1111 1110 1010 1011 1001 1000                                            |
| $G_4$ :   | 0000 0001 0011 0010 0110 0111 0101 0100 1100 1101 1111<br>1110 1010 1011 1001 1000 |

20. Let  $C$  be a Hamiltonian cycle in  $G$ . Consider a traversal of  $C$ . When we traverse an edge from a vertex  $v_1$  in  $V_1$  to a vertex  $v_2$  in  $V_2$ , this uniquely associates one vertex  $v_2$  with  $v_1$ . Since  $C$  traverses all vertices  $|V_1| = |V_2|$ .

22. Let each vertex of a graph represent a permutation. Put an edge between two vertices  $p$  and  $q$  if and only if  $p_i \neq q_i$  for all  $i = 1, 2, \dots, n$ .

23.  $(n = 1)$  1

$(n = 2)$  12 21

$(n = 3)$  Consider a graph with six vertices representing the permutations and with an edge between two vertices if the permutations differ in each coordinate. A solution to the problem is a Hamiltonian path in the graph. There is no solution for  $n = 3$  because the graph is not connected.

$(n = 4)$  1234 3412 4321 1432 2341 4132 3241 4123 3214 1423 2314 1243 2134 3421 4312 2431  
1342 4231 3142 4213 3124 2413 1324 2143

26. No. Consider Figure 8.3.5.

27. Yes,  $(v_1, v_2, v_5, v_4, v_3)$ .

29. No. Suppose the graph has a Hamiltonian path. First note that the path must either start or end at either  $a$  or  $c$ . If not, we must use edges  $(a, b)$ ,  $(a, d)$ ,  $(b, c)$ , and  $(c, d)$ , which make a cycle. Similarly, the path must start or end at either  $j$  or  $l$ . Suppose that the path starts at  $a$ . The path begins with either  $(a, b)$  or  $(a, d)$ . By symmetry, we may assume that the path begins with  $(a, d)$ .

First suppose that the path ends at  $l$ . Since the path does not end at  $c$ , it must include edges  $(b, c)$  and  $(c, d)$ . Also, since the path does not end at  $j$ , it must include edges  $(i, j)$  and  $(j, k)$ . The path must include either  $(b, e)$  or  $(b, f)$ . If  $(b, e)$  is in the path, then  $(f, e)$  and  $(f, i)$  must be in the path. Since the path ends at  $l$ , it must contain  $(l, k)$ . If  $(b, f)$  is in the path, then  $(f, e)$  and  $(e, i)$  must be in the path. Again, since the path ends at  $l$ , it must contain  $(l, k)$ . In either case,  $h$  must have degree one, which is a contradiction. Therefore the path cannot end at  $l$ .

Now suppose that the path ends at  $j$ . Since the path does not end at  $c$ , it must include edges  $(b, c)$  and  $(c, d)$ . Also, since the path does not end at  $l$ , it must include edges  $(i, l)$  and  $(k, l)$ . Arguing as in the previous case, we find that either  $e$  or  $f$  connects to  $i$ . Since the path ends at  $j$ , it must include  $(j, k)$ . Again,  $h$  must have degree one, which is a contradiction. Therefore the path cannot end at  $j$ .

Now suppose that the path begins at  $c$ . By symmetry, we may assume that the path begins with  $(c, d)$ . Since the path does not end at  $a$ , it must include edges  $(d, a)$  and  $(a, b)$ . Now the argument is exactly as in the preceding paragraphs; again a contradiction is reached. The proof is complete.

30. No. We would have to eliminate at least one edge at  $f$ , at least three edges at  $c$ , at least one edge at  $b$ , at least one edge at  $i$ , at least three edges at  $j$ , at least three edges at  $m$ , and at least one edge at  $p$  leaving 14 edges. Since there are 16 vertices, a Hamiltonian path would have 15 edges.
32. Yes,  $(a, b, c, j, i, m, k, d, e, f, l, g, h)$
33. Yes,  $(a, b, c, g, l, m, r, q, p, k, j, f, e, i, n, o, t, s, h, d)$
35. The graph contains a Hamiltonian path for all  $m$  and  $n$ . Start in the upper-left corner. Continue right until reaching the end of this row. Drop down to the next row. Continue left until reaching the end of this row. Drop down to the next row. Now repeat, continue right until reaching the end of this row ... Continue until all vertices have been visited.
36. For all  $n$

## Section 8.4

2. 11;  $(a, b, c, g)$       3. 10;  $(a, b, c, d, z)$       5. 10;  $(h, f, c, d)$
7. Change line 8 of Algorithm 8.4.1 to
- while  $(T \neq \emptyset)$  {
8.    Input:    A connected, weighted graph with  $n$  vertices in which  
                  all weights are positive (if there is no edge between  $i$  and  $j$ ,  
                  set  $w(i, j) = \infty$ )
- Output:  $\text{dist}(i, j)$ , the length of a shortest path from  $i$  to  $j$  for all  $i$   
                  and  $j$

```

all_paths(w, n) {
 for j = 1 to n
 for k = 1 to n
 dist(j, k) = w(j, k)
 for i = 1 to n
 for j = 1 to n
 for k = 1 to n
 if (dist(j, i) + dist(i, k) < dist(j, k))
 dist(j, k) = dist(j, i) + dist(i, k)
}

```

10. False

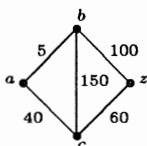

11. False

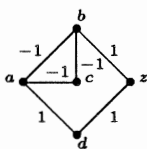

## Section 8.5

2. Relative to the ordering  $a, b, c, d, e, f, g$ , the adjacency matrix is

$$\begin{pmatrix} 0 & 2 & 0 & 0 & 0 & 0 & 0 \\ 2 & 0 & 1 & 0 & 1 & 0 & 0 \\ 0 & 1 & 2 & 0 & 1 & 0 & 0 \\ 0 & 0 & 0 & 2 & 1 & 0 & 1 \\ 0 & 1 & 1 & 1 & 0 & 1 & 0 \\ 0 & 0 & 0 & 0 & 1 & 0 & 1 \\ 0 & 0 & 0 & 1 & 0 & 1 & 0 \end{pmatrix}$$

3. Relative to the ordering  $a, b, c, d, e$ , the adjacency matrix is

$$\begin{pmatrix} 0 & 1 & 0 & 0 & 0 \\ 1 & 0 & 0 & 0 & 0 \\ 0 & 0 & 0 & 1 & 1 \\ 0 & 0 & 1 & 0 & 1 \\ 0 & 0 & 1 & 1 & 0 \end{pmatrix}$$

5. Every entry is one except along the main diagonal, which consists of zeros.



6. If  $V_1 = \{a, b\}$  and  $V_2 = \{c, d, e\}$  are the vertex sets and the ordering is  $a, b, c, d, e$ , the adjacency matrix is

$$\begin{pmatrix} 0 & 0 & 1 & 1 & 1 \\ 0 & 0 & 1 & 1 & 1 \\ 1 & 1 & 0 & 0 & 0 \\ 1 & 1 & 0 & 0 & 0 \\ 1 & 1 & 0 & 0 & 0 \end{pmatrix}$$

8. Relative to the orderings  $x_1, x_2, x_3, x_4, x_5, x_6, x_7, x_8, x_9, x_{10}, x_{11}$  and  $a, b, c, d, e, f, g$ , the adjacency matrix is

$$\begin{pmatrix} 1 & 0 & 0 & 0 & 0 & 0 & 0 & 0 & 0 & 0 & 0 \\ 1 & 1 & 0 & 1 & 0 & 0 & 0 & 0 & 0 & 0 & 0 \\ 0 & 1 & 1 & 0 & 0 & 0 & 0 & 1 & 0 & 0 & 0 \\ 0 & 0 & 0 & 0 & 1 & 1 & 1 & 0 & 0 & 0 & 0 \\ 0 & 0 & 0 & 1 & 0 & 0 & 1 & 1 & 0 & 1 & 1 \\ 0 & 0 & 0 & 0 & 0 & 0 & 0 & 0 & 1 & 1 & 1 \\ 0 & 0 & 0 & 0 & 0 & 1 & 0 & 0 & 1 & 0 & 0 \end{pmatrix}$$

9. Relative to the orderings  $x_1, x_2, x_3, x_4$  and  $a, b, c, d, e$  the adjacency matrix is

$$\begin{pmatrix} 1 & 0 & 0 & 0 \\ 1 & 0 & 0 & 0 \\ 0 & 1 & 1 & 0 \\ 0 & 0 & 1 & 1 \\ 0 & 1 & 0 & 1 \end{pmatrix}$$

11. 
$$\begin{pmatrix} 1 & 1 & 1 & 1 & 0 & 0 & 0 & 0 & 0 & 0 \\ 1 & 0 & 0 & 0 & 1 & 1 & 1 & 0 & 0 & 0 \\ 0 & 1 & 0 & 0 & 1 & 0 & 0 & 1 & 1 & 0 \\ 0 & 0 & 1 & 0 & 0 & 1 & 0 & 1 & 0 & 1 \\ 0 & 0 & 0 & 1 & 0 & 0 & 1 & 0 & 1 & 1 \end{pmatrix}$$

12. 
$$\begin{pmatrix} 1 & 1 & 1 & 0 & 0 & 0 \\ 0 & 0 & 0 & 1 & 1 & 1 \\ 1 & 0 & 0 & 1 & 0 & 0 \\ 0 & 1 & 0 & 0 & 1 & 0 \\ 0 & 0 & 1 & 0 & 0 & 1 \end{pmatrix}$$

14.

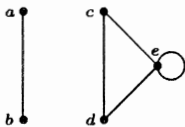

15.

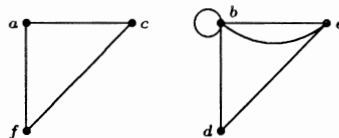

17.

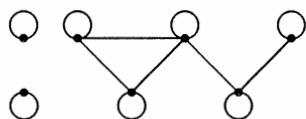

18. (For Exercise 15) The first matrix is relative to the ordering  $a, c, f$  and the second is relative to the ordering  $b, d, e$ .

$$\begin{pmatrix} 0 & 1 & 1 \\ 1 & 0 & 1 \\ 1 & 1 & 0 \end{pmatrix} \quad \begin{pmatrix} 2 & 1 & 2 \\ 1 & 0 & 1 \\ 2 & 1 & 0 \end{pmatrix}$$

20. 93      21. The graph is not connected.

25.

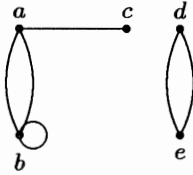

26. The vertex corresponding to the row of zeros is an isolated vertex.

29. Use the fact that

$$\begin{pmatrix} d_{n+1} & a_{n+1} & \cdots & a_{n+1} \\ \cdot & & & \cdot \\ \cdot & & & \cdot \\ \cdot & & & \cdot \\ a_{n+1} & a_{n+1} & \cdots & d_{n+1} \end{pmatrix} = A^{n+1} = \begin{pmatrix} d_n & a_n & \cdots & a_n \\ a_n & d_n & \cdots & a_n \\ \cdot & & & \cdot \\ \cdot & & & \cdot \\ a_n & a_n & \cdots & d_n \end{pmatrix} \begin{pmatrix} 0 & 1 & 1 & 1 & 1 \\ 1 & 0 & 1 & 1 & 1 \\ 1 & 1 & 0 & 1 & 1 \\ 1 & 1 & 1 & 0 & 1 \\ 1 & 1 & 1 & 1 & 0 \end{pmatrix}.$$

30. We solve the second-order linear homogeneous recurrence relation (see Exercise 29)

$$a_n = 3a_{n-1} + 4a_{n-2}$$

by the method of Section 7.2.

Solving the equation

$$t^2 - 3t - 4 = 0$$

for  $t$ , we obtain  $t = 4$  and  $t = -1$ . Thus the solution is of the form

$$a_n = b4^n + d(-1)^n.$$

The initial conditions give the equations

$$\begin{aligned} 1 &= a_1 = 4b - d \\ 3 &= a_2 = 16b + d. \end{aligned}$$

Solving for  $b$  and  $d$ , we obtain  $b = 1/5$  and  $d = -1/5$ . Therefore

$$a_n = \frac{4^n}{5} - \frac{(-1)^n}{5} = \frac{1}{5}[4^n + (-1)^{n+1}].$$

## Section 8.6

2. The graphs are isomorphic:  $f(a) = 1, f(b) = 3, f(c) = 5, f(d) = 7, f(e) = 2, f(f) = 4, f(g) = 6. g((x, y)) = (f(x), f(y)).$
3. The graphs are not isomorphic since  $G_1$  has a simple cycle of length 3 and  $G_2$  does not.
5. The graphs are isomorphic:  $f(a) = 3, f(b) = 4, f(c) = 1, f(d) = 5, f(e) = 2. g((x, y)) = (f(x), f(y)).$
6. The graphs are isomorphic:  $f(a) = 1, f(b) = 5, f(c) = 6, f(d) = 2, f(e) = 3, f(f) = 7, f(g) = 8, f(h) = 4, f(i) = 9, f(j) = 10, f(k) = 11, f(l) = 12. g((x, y)) = (f(x), f(y)).$
8. The graphs are not isomorphic. The edge  $(1, 4)$  in  $G_2$  has  $\delta(1) = 3$  and  $\delta(4) = 3$  but there is no such edge in  $G_1$  (see also Exercise 15).
9. The graphs are not isomorphic.  $G_1$  has two simple cycles of length 3, but  $G_2$  has only one simple cycle of length 3 (see also Exercise 14).
11. Extend the definition in Example 8.6.3 as follows:  $f(v) = v_1v_2 \dots v_k$ , where  $v_i$  is the  $i$ th coordinate determined as the members of a  $t_i$  Gray code. Note that if  $(v, w)$  is an edge in  $M$ , the strings  $v_1v_2 \dots v_k$  and  $w_1w_2 \dots w_k$  will differ in exactly one bit. So,  $(v, w)$  is an edge of the  $(t_1 + t_2 + \dots + t_k)$ -cube. Define  $g$  on the edges of  $M$  by

$$g((v, w)) = (v_1v_2 \dots v_k w_1w_2 \dots w_k).$$

$f$  and  $g$  define an isomorphism from  $M$  onto the subgraph  $(V, E)$  of the  $(t_1 + t_2 + \dots + t_k)$ -cube where

$$\begin{aligned} V &= \{f(v) \mid v \text{ is a vertex in } M\}, \\ E &= \{f(e) \mid e \text{ is an edge in } M\}. \end{aligned}$$

13. Suppose that  $G_1$  and  $G_2$  are isomorphic. We use the notation of Definition 8.6.1. Suppose that  $G_1$  has  $n$  vertices  $v_1, \dots, v_n$  of degree  $k$  and that  $G_2$  has  $m$  vertices of degree  $k$ . By Example 8.6.8,  $f(v_1), \dots, f(v_n)$  each have degree  $k$  in  $G_2$ . Therefore  $m \geq n$ . By symmetry,  $m \leq n$ . Thus  $m = n$ .
14. We use the notation of Definition 8.6.1. Suppose that  $G_1$  is connected. We must show that  $G_2$  is connected. Let  $v'$  and  $w'$  be distinct vertices in  $G_2$ . Then there exist vertices  $v$  and  $w$  in  $G_1$  with  $f(v) = v'$  and  $f(w) = w'$ . Since  $G_1$  is connected, there exists a path  $(v_0, v_1, \dots, v_n)$  in  $G_1$  with  $v_0 = v$  and  $v_n = w$ . Now  $(f(v_0), f(v_1), \dots, f(v_n))$  is a path in  $G_2$  from  $v'$  to  $w'$ . Therefore  $G_2$  is connected.
16. Let  $(v, w)$  be an edge in  $G_1$  with  $\delta(v) = i$  and  $\delta(w) = j$ . Example 8.6.8 shows that  $\delta(f(v)) = i$  and  $\delta(f(w)) = j$ . Now the edge  $(f(v), f(w))$  has the desired property in  $G_2$ .
19. Not an invariant

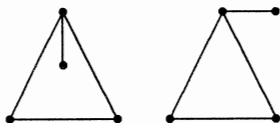

20. Invariant

22.



23.

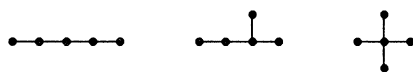

27.

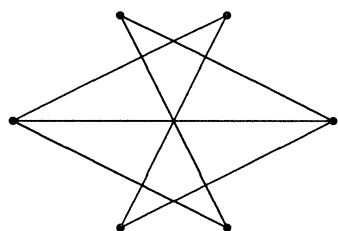

28. Suppose that  $G$  is not connected. Let  $C$  be a component of  $G$  and let  $V_1$  be the set of vertices in  $G$  that belong to  $C$ . Let  $V_2$  be the set of vertices in  $G$  not in  $V_1$ . In  $\overline{G}$ , for every  $v_1 \in V_1$  and  $v_2 \in V_2$ , there is an edge  $e$  incident on  $v_1$  and  $v_2$ . Thus, in  $\overline{G}$  there is a path from  $v$  to  $w$  if  $v \in V_1$  and  $w \in V_2$ . Suppose that  $v$  and  $w$  are in  $V_1$ . Choose  $x \in V_2$ . Then  $(v, x, w)$  is a path from  $v$  to  $w$ . Similarly if  $v$  and  $w$  are in  $V_2$ , there is a path from  $v$  to  $w$ . Thus  $\overline{G}$  is connected.

30. Suppose that  $G_1$  and  $G_2$  are isomorphic. We use the notation of Definition 8.6.1. We construct an isomorphism for  $\overline{G_1}$  and  $\overline{G_2}$ . The function  $f$  is unchanged. Let  $(v, w)$  be an edge in  $\overline{G_1}$ . Set  $g((v, w)) = (f(v), f(w))$ .

It can be verified that the functions  $f$  and  $g$  provide an isomorphism of  $\overline{G_1}$  and  $\overline{G_2}$ .

If  $\overline{G_1}$  and  $\overline{G_2}$  are isomorphic, by the preceding result,  $\overline{\overline{G_1}} = G_1$  and  $\overline{\overline{G_2}} = G_2$  are isomorphic.

31. Yes

34.  $f(1) = w, f(2) = x, f(3) = y, f(4) = z, f(5) = y, f(6) = x$

35.  $f(1) = a, f(2) = b, f(3) = c, f(4) = d, f(5) = c, f(6) = b$

37.  $f(a) = 1, f(b) = 2, f(c) = 3, f(d) = 4, f(e) = 5, f(f) = 3, f(g) = 2$

38. See [Hell].

Section 8.7

2.

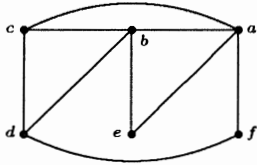

3.

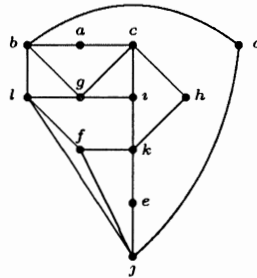

5. Remove  $(g, e)$  and  $(a, c)$  to obtain a graph homeomorphic to

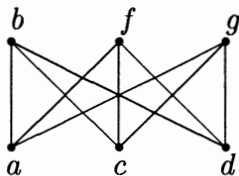

7. Planar

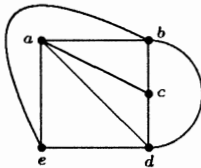

8. Not planar. The following graph is homeomorphic to  $K_{3,3}$ .

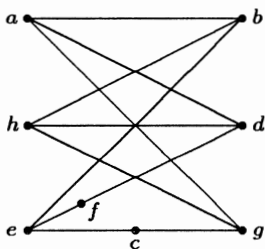

11. Let  $G$  be a graph having four or fewer vertices. By Exercise 10, the planarity of  $G$  is not affected by deleting loops or parallel edges; so we can assume that  $G$  has neither loops nor parallel edges. Now  $G$  is a subgraph of  $K_4$  and, since  $K_4$  is planar, so is  $G$ .

13. Since every cycle has at least three edges, each face is bounded by at least three edges. Thus the number of edges that bound faces is at least  $3f$ . In a planar graph, each edge belongs to at most two bounding cycles. Therefore  $2e \geq 3f = 3(e - v + 2)$ . Thus  $3v - 6 \geq e$ .

14.  $K_{3,3}$

16. Suppose that  $G$  and  $\overline{G}$  are both planar. Let  $v$  denote the number of vertices in  $G$ . Let  $e$  (respectively,  $\bar{e}$ ) denote the number of edges in  $G$  (respectively,  $\overline{G}$ ). If either  $G$  or  $\overline{G}$  is not

connected, add just enough edges, preserving planarity, to connect it. Let the connected graphs so obtained be denoted  $G^*$  (with  $e^*$  edges) and  $\overline{G^*}$  with  $\overline{e^*}$  edges). Using Exercise 13, we obtain

$$\frac{v(v-1)}{2} = e + \overline{e} \leq e^* + \overline{e^*} \leq 2(3v-6).$$

Thus

$$v^2 - 13v + 24 \leq 0.$$

The roots of the equation obtained by replacing  $\leq$  by  $=$  are

$$x = \frac{13 \pm \sqrt{73}}{2},$$

so

$$v \leq \frac{13 + \sqrt{73}}{2} < 11.$$

17. See *Amer. Math. Mo.*, April 1983, pages 287–288.
19. Pick a city in each country. Draw a line through the common border between two cities in countries sharing a common border. This can be done with no lines crossing.
20. Color  $D$ , say, red. Now  $B$  and  $C$  must be different colors and different from red.
21.  $A$ –red,  $B$ –green,  $C$ –blue,  $D$ –red,  $E$ –green,  $F$ –blue,  $G$ –green
23. Color  $L$  red. Now  $G$  needs a different color—say blue. Now  $K$  needs a color different from  $L$  and  $G$ —say yellow. Now  $J$  needs a fourth color.
24.  $A$ –blue,  $B$ –green,  $C$ –red,  $D$ –yellow,  $E$ –green,  $F$ –red,  $G$ –yellow,  $H$ –green,  $I$ –yellow,  $J$ –green,  $K$ –blue,  $L$ –red
26. Suppose that  $G'$  can be colored with  $n$  colors. If we eliminate edges from  $G'$  to obtain  $G$ ,  $G$  is colored with  $n$  colors.
27. Each face is bounded by three edges and each edge is in a boundary for two faces.
29. Suppose that  $G$  has a vertex of degree 3. Then, we find the configuration

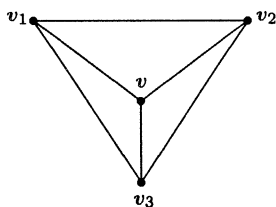

Consider the map  $G'$  obtained from  $G$  by removing vertex  $v$  and the three edges incident on  $v$ . By assumption,  $G'$  can be colored with four colors. Now  $v_1$ ,  $v_2$ , and  $v_3$  require at most three colors. Color  $v$  with the fourth color. Now  $G$  is colored with four colors—a contradiction.

30. If  $G$  has a vertex  $v$  of degree 4, we find the configuration

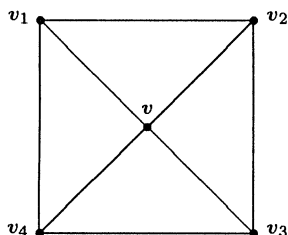

Consider the graph  $G'$  obtained from  $G$  by removing vertex  $v$  and the four edges incident on  $v$ . By assumption,  $G'$  can be colored with four colors. Show that if  $v_1, v_2, v_3,$  and  $v_4$  use three or fewer colors, we get an immediate contradiction.

Suppose that  $v_1, v_2, v_3,$  and  $v_4$  require four colors and that  $v_i$  is colored  $C_i$ . Consider the subgraph  $G'_1$  of  $G'$  consisting of all simple paths starting at  $v_1$  whose vertices are alternately colored  $C_1$  and  $C_3$ . If  $G'_1$  does not include  $v_3$ , we may change each  $C_1$  to  $C_3$  and each  $C_3$  to  $C_1$  in  $G'_1$  and produce a coloring of  $G'$  with four colors. If this is done, we can then color  $G$  with four colors.

Suppose that  $G'_1$  includes  $v_3$ . Consider the subgraph  $G'_2$  of  $G'$  consisting of all simple paths starting at  $v_2$  whose vertices are alternately colored  $C_2$  and  $C_4$ . Show that  $G'_2$  cannot include  $v_4$ . We may change each  $C_2$  to  $C_4$  and each  $C_4$  to  $C_2$  in  $G'_2$  and produce a coloring of  $G'$  with four colors. If this is done, we can then color  $G$  with four colors.

Deduce that  $G$  cannot have a vertex of degree 4.

32. Use the methods of Exercise 29–31.

### Section 8.8

2.

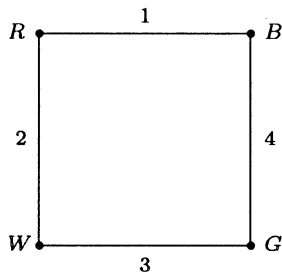
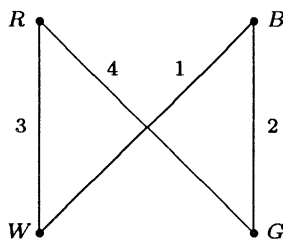

3.

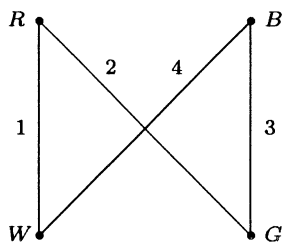
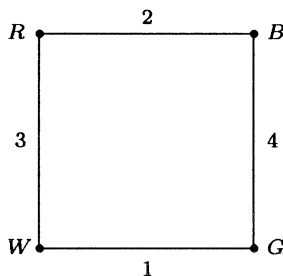

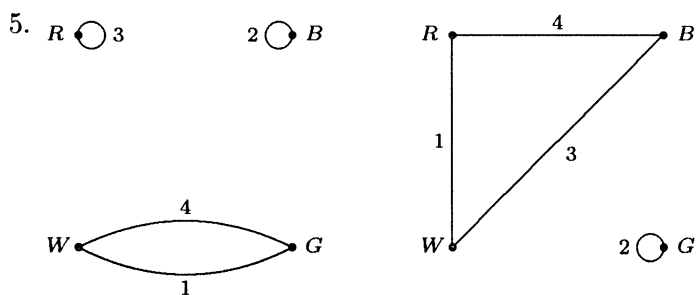

6. There is no solution.

8. (a)

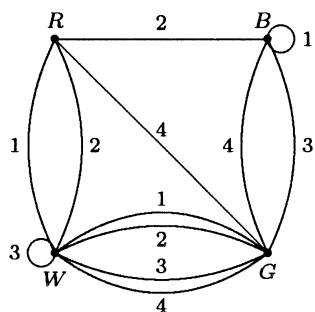

(b)

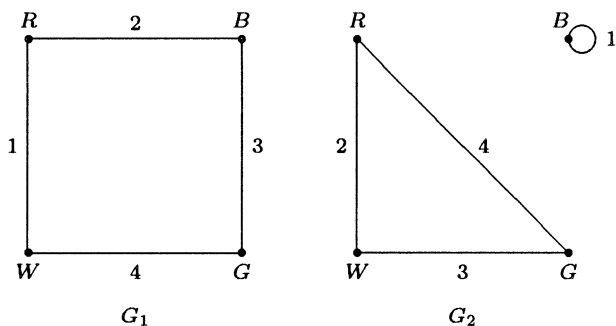

(c)

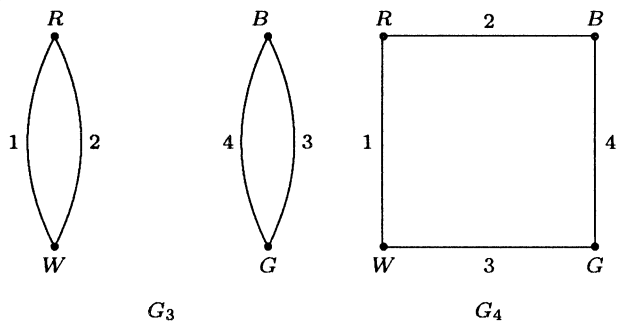

(d) Note that  $G_i$  and  $G_j$  have edges in common for  $i = 1, j = 3; i = 1, j = 4; i = 3, j = 4; i = 2, j = 3; \text{ and } i = 2, j = 4$ . Thus the only solution is  $G_1, G_2$ .

9. We cannot select the edge incident on  $R$  and  $B$  for, if we do, there is no way to make the degree of  $R = 2$ . Similarly, we cannot select the edge incident on  $B$  and  $G$  for, if we do, there is no way to make the degree of  $B = 2$ . Since we must have an edge labeled 4, we must select the



loop incident on  $W$ . This means we cannot select any of the edges incident on  $W$  and  $G$ . Now,  $G$  cannot have degree 2. Thus, no subgraph satisfies (8.8.1) and (8.8.2).

11. There are six choices for the top and, having chosen the top, there are four choices for the front for a total of  $6 \cdot 4 = 24$  choices.
12. By Exercise 11, there are 24 orientations of one cube. Thus there are  $24^4 = 331,776$  stackings.
14. Let

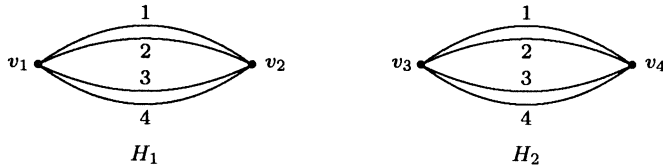

be subgraphs of the graph representing the four cubes in the puzzle such that the intersection of the edge sets and the intersection of the vertex sets are empty.

We can use  $H_1$  to construct front and back sides of the stack with the front having color  $v_1$  and back having color  $v_2$ . This is possible since the edges incident on  $v_1$  and  $v_2$  contain all the labels 1, 2, 3, and 4. Similarly,  $H_2$  can be used to construct the left and right sides of the stack with the left color  $v_3$  and the right color  $v_4$ .

Any solution is of this form, for if a solution exists, let  $v_1, v_2, v_3,$  and  $v_4$  be the colors of the front, back, left, and right faces of the solution stack. Then  $v_1$  and  $v_2$  appear on opposite faces of all four cubes, and  $v_3$  and  $v_4$  appear on the other opposite faces of all four cubes. Thus  $H_1$  and  $H_2$  exist in the graph, as shown previously, representing the solution stack.

- 16.

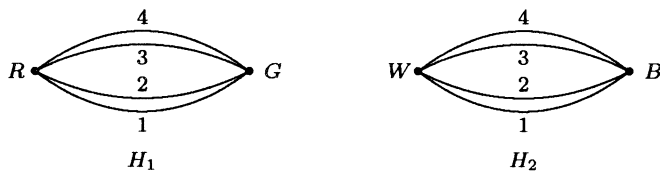

- 17.

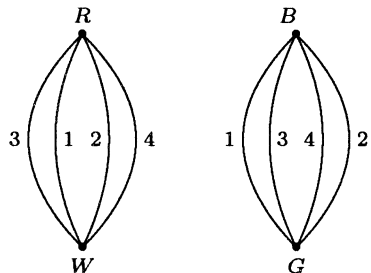

18. There is no solution.
20. Let  $H_1$  and  $H_2$  be a solution to the modified version as in, for example, the solution to Exercise 16. We construct subgraphs  $G_1$  and  $G_2$  as follows. We let the vertex set of  $G_1$  be  $\{R, B, G, W\}$ .

We let the edge set of  $G_1$  be the set of edges labeled 1, 2 from  $H_1$  and the edges labeled 3, 4 from  $H_2$ . We let the vertex set of  $G_2$  be  $\{R, B, G, W\}$ . We let the edge set of  $G_2$  be the set of edges labeled 3, 4 from  $H_1$  and the edges labeled 1, 2 from  $H_2$ .

21. Yes. See the graph of Exercise 9.

# Chapter 9

## Solutions to Selected Exercises

### Section 9.1

- 2. This graph is not a tree because, if  $v$  is the upper-left vertex and  $w$  is the bottom, middle vertex, there are two simple paths from  $v$  to  $w$ .
- 3. This graph is not a tree because, if  $v$  is the left, middle vertex and  $w$  is the left, bottom vertex, there is no simple path from  $v$  to  $w$ .
- 5. If either  $m$  or  $n$ , or both, equals 1
- 6.  $n = 1, 2$

9. 4      10. 5

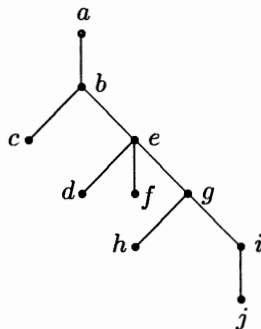

12.

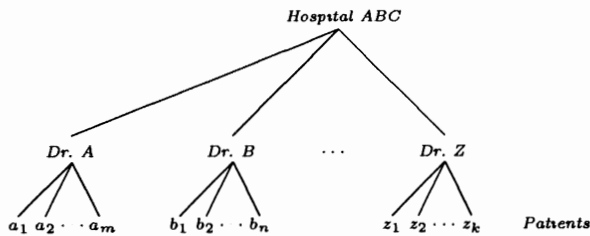

15. *LAP*      16. *DEAL*      19. 010000001111      20. 0111000100111100010

- 22. Overhead in decoding, memory addressing capability, compatibility with other systems, amount of memory available
- 23. See G. Williams and R. Meyer, "The Panasonic and Quasar hand-held computers: beginning a new generation of consumer computers," *BYTE*, 6 (January 1981), 34–45.

25.

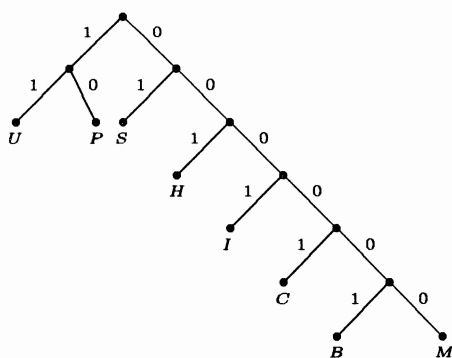

28.

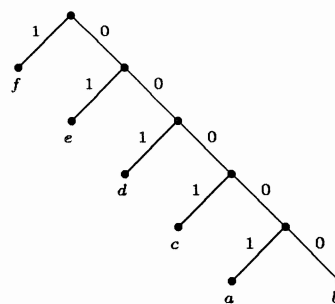

29. The proposed code is ambiguous. For example, 01 could represent  $EA$  or  $C$ .
30. A terminal vertex has degree 1.
31. Since  $K_{3,3}$  and  $K_5$  contain cycles, a tree cannot contain a subgraph homeomorphic to either; thus, a tree is planar.
33. Consider the tree to be rooted. Color the vertices on even levels one color and those on odd levels another color.
34.  $a-5, b-4, c-5, d-4, e-3, f-4, g-3, h-4, i-4, j-5$

36. In this solution, we call a simple path in a tree from the root to a terminal vertex a *drop*. Also, we let  $\text{ecc}(v)$  denote the eccentricity of the vertex  $v$ .

Let  $c$  be a center of a tree  $T$ . Root  $T$  at  $c$ . Notice that if  $\text{ecc}(c) = L$ , the height of  $T$  is  $L$ .

We first show that no vertex on level 2 or greater can be a center. For suppose that there is a center  $c'$  on level two or greater. Then  $\text{ecc}(c') = L$ . A simple path starting at  $c'$  of length  $L$  must pass through  $c$ . But now any simple path starting at the parent of  $c'$  has length at most  $L - 1$ . This contradicts the definition of "center."

Notice that no vertex different from  $c$  on a drop whose length is less than  $L$  can be a center. Thus the only possible centers besides  $c$  are the children of  $c$  which lie on drops of length  $L$ . It is easy to see that if  $c$  has at least two children each lying on a drop of length  $L$ , then  $c$  is the unique center. If  $c$  has a unique child  $c'$  lying on a drop of length  $L$ ,  $c$  and  $c'$  are the only centers.

37. In the solution to Exercise 36, we showed that all centers are on level 0 or level 1. Therefore the centers are adjacent.
39. In the following tree,  $(a, b)$  and  $(a, b, a, b)$  are distinct paths from  $a$  to  $b$ .



## Section 9.2

2. Aphrodite, Uranus
3. Aphrodite, Kronos, Atlas, Prometheus

5. Zeus, Poseidon, Hades

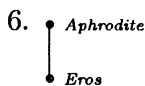

8. Ancestors of  $c$ :  $b, a$ . Ancestors of  $j$ :  $e, c, b, a$ .

9. Children of  $d$ :  $h, i$ . Child of  $e$ :  $j$ .

11. Siblings of  $f$ :  $e, g$ . Sibling of  $h$ :  $i$ .

12. Terminal vertices:  $j, f, g, h, i$

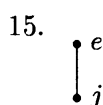

18. They are siblings.

19. It is the root.

20. One is the ancestor of the other.

21. It is a terminal vertex.

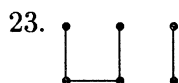

24. No such graph exists. A terminal vertex has degree 1.

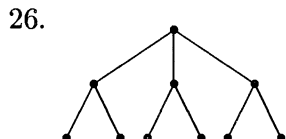

28. In this case, if the edge is  $(v, w)$ , we would have the cycle  $(v, w, v)$ .

29. The graph is not a tree since, according to Definition 9.1.1, a tree is a *simple* graph satisfying: If  $v$  and  $w$  are vertices, there is a unique simple path from  $v$  to  $w$ .

31.  $n - m$

32. No. Consider the paths  $(a, c, d, b)$  and  $(a, e, d, c, f, b)$  in the graph

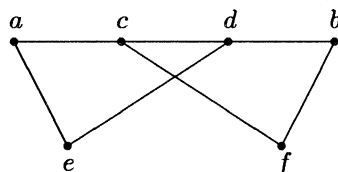

34. First, suppose that  $T$  is a tree. By Theorem 9.2.3b,  $T$  is connected. Suppose that for some vertex pair  $v, w$ , when edge  $(v, w)$  is added, at least two cycles are created. Then there must be at least two distinct simple paths from  $v$  to  $w$  to account for the distinct cycles. But this contradicts the definition of a tree.

Now suppose that  $T$  is connected and when an edge is added between any two vertices, exactly one cycle is created. It follows that if  $v$  and  $w$  are vertices in  $T$ , there is a unique simple path from  $v$  to  $w$ . For if there were no simple path from  $v$  to  $w$ , inserting an edge between  $v$  and  $w$

would not create a cycle. If there were two or more simple paths between  $v$  and  $w$ , inserting an edge between  $v$  and  $w$  would create two or more cycles. Thus  $T$  is a tree by the definition of tree.

35. Let  $v$  be a vertex of degree at least 2 in a tree  $G$  and let  $P = (v_0, \dots, v_n)$  be a simple path of maximum length passing through  $v$ . Since  $G$  is a tree,  $P$  is not a cycle and, since  $v$  has degree at least 2,  $v \neq v_0$  and  $v \neq v_n$ . If removing  $v$  and all edges incident on  $v$  leaves a connected graph, then there is a simple path, distinct from  $P$ , from  $v_0$  to  $v_n$ . Since  $G$  is a tree, this is impossible. Therefore  $v$  is an articulation point.

### Section 9.3

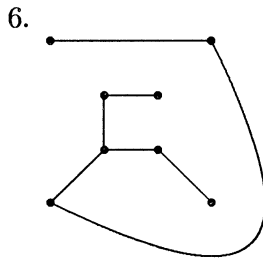
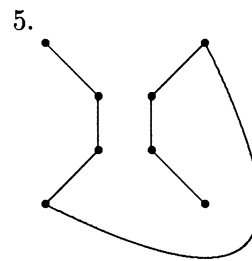
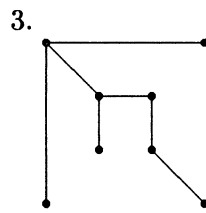
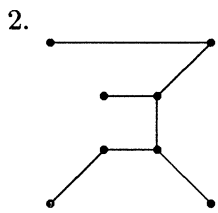

8. The cycle  $(a, b, c, d, e, f, g, h, i, j, k, l)$

9.

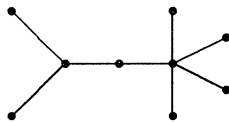

11.

|   |   |   |   |   |
|---|---|---|---|---|
|   |   | x |   |   |
| x |   |   |   |   |
|   |   |   | x |   |
|   | x |   |   |   |
|   |   |   |   | x |

|   |   |   |   |   |   |
|---|---|---|---|---|---|
|   |   |   | x |   |   |
| x |   |   |   |   |   |
|   |   |   |   | x |   |
|   | x |   |   |   |   |
|   |   |   |   |   | x |
|   |   | x |   |   |   |

12. False. Consider  $K_4$ . A breadth-first search spanning tree will produce a tree whose root has degree 3. Thus it cannot produce the tree  $(a, b, c, d)$ .
14. If  $T$  is a tree, every vertex ordering with the same initial vertex produces the same spanning tree, namely  $T$  itself.

15. If  $T$  is a tree, every vertex ordering with the same initial vertex produces the same spanning tree, namely  $T$  itself.
17. First show that the graph  $T$  constructed is a tree. Now use induction on the number of iterations of the loop to show that  $T$  contains all of the vertices of  $G$ .
18. If the edge is not contained in a cycle of  $G$
20. Input: A connected graph  $G$  with vertices ordered  $v_1, \dots, v_n$ ; and  $d$   
Output:  $d(v_i)$  = length of a shortest path from  $v_1$  to  $v_i$

```

short_paths(V, E, d) {
 $S = (v_1)$
 $V' =$ set consisting of v_1
 $E' = \emptyset$
 $d(v_1) = 0$
 while (true) {
 for each $x \in S$, in order
 for each $y \in V - V'$, in order
 if ((x, y) is an edge) {
 add edge (x, y) to E' and y to V'
 $d(y) = d(x) + 1$
 }
 }
 if (no edges were added)
 return T
 $S =$ children of S ordered consistently with the original vertex ordering
 }
}

```

21. Both algorithms find simple paths from  $v$  in increasing order of length.
24. The fundamental cycle matrix relative to the orderings  $(a, b, a)$ ,  $(b, d, c, b)$ ,  $(b, c, f, b)$ ,  $(d, e, c, d)$ ,  $(c, f, e, c)$ ,  $(c, e, g, d, c)$ ,  $(c, f, g, d, c)$  and  $e_2, e_3, e_5, e_{12}, e_{13}, e_{10}, e_{11}, e_1, e_4, e_6, e_7, e_8, e_9$  is

$$\begin{pmatrix} 1 & 0 & 0 & 0 & 0 & 0 & 0 & 1 & 0 & 0 & 0 & 0 & 0 \\ 0 & 1 & 0 & 0 & 0 & 0 & 0 & 0 & 1 & 1 & 0 & 0 & 0 \\ 0 & 0 & 1 & 0 & 0 & 0 & 0 & 0 & 1 & 0 & 0 & 1 & 0 \\ 0 & 0 & 0 & 1 & 0 & 0 & 0 & 0 & 0 & 1 & 1 & 0 & 0 \\ 0 & 0 & 0 & 0 & 1 & 0 & 0 & 0 & 0 & 0 & 1 & 1 & 0 \\ 0 & 0 & 0 & 0 & 0 & 1 & 0 & 0 & 0 & 1 & 1 & 0 & 1 \\ 0 & 0 & 0 & 0 & 0 & 0 & 1 & 0 & 0 & 1 & 0 & 1 & 1 \end{pmatrix}$$

25. The fundamental cycle matrix relative to the orderings  $(a, b, d, e, a)$ ,  $(a, b, d, e, a)'$ ,  $(b, c, d, b)$ ,  $(d, e, f, d)$ , and  $e_3, e_4, e_2, e_9, e_1, e_5, e_6, e_7, e_8$  is

$$\begin{pmatrix} 1 & 0 & 0 & 0 & 1 & 1 & 0 & 1 & 0 \\ 0 & 1 & 0 & 0 & 1 & 1 & 0 & 1 & 0 \\ 0 & 0 & 1 & 0 & 0 & 1 & 1 & 0 & 0 \\ 0 & 0 & 0 & 1 & 0 & 0 & 0 & 1 & 1 \end{pmatrix}$$

27. Modify Algorithm 9.3.7 as follows. Change the line return  $T$  to

```

if ($|V'| == n$)
 return true
else
 return false

```

If the graph is connected, the value true is returned; otherwise, the value false is returned.

28. Modify Algorithm 9.3.10 as follows. Change the line return true to

```
print solution
```

Delete the line return false.

## Section 9.4

2.

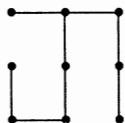

3.

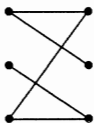

5.

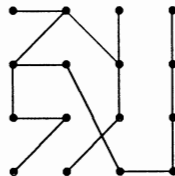

6. Suppose that the start vertex is 1, and that the vertices are added in the order  $1, 2, \dots, n$ . When  $i$  is 1 and  $j$  is 1, the innermost line (line 11) of the nested for loops is executed  $n$  times. When  $i$  is 2, the innermost line of the nested for loops is executed  $n$  times for each of the values  $j = 1, 2$ . When  $i$  is 3, the innermost line of the nested for loops is executed  $n$  times for each of the values  $j = 1, 2, 3$ ; and so on. Thus line 11 is executed

$$n + 2n + 3n + \dots + (n-1)n = n[1 + 2 + 3 + \dots + (n-1)] = \frac{n(n-1)n}{2} = \Theta(n^3)$$

times. No input requires more than  $\Theta(n^3)$  time since the nested for loops take at most  $O(n^3)$  time to execute. Therefore the worst-case time is  $\Theta(n^3)$ .

8. The body of the last for loop executes  $n-1$  times the first time,  $n-2$  times the second time, and so on. This time dominates, so the worst-case time is

$$(n-1) + (n-2) + \dots + 1 = \frac{(n-1)n}{2} = \Theta(n^2).$$

9. The argument is similar to the proof of Theorem 9.4.5.

11. Yes



12. Suppose that the weight of each edge in  $K_n$  is equal to 2. Suppose that some algorithm does not examine edge  $e$ . Let  $T$  denote the minimal spanning tree output by the algorithm. If  $e$  is in  $T$ , alter the input by changing the weight of  $e$  to 3. If  $e$  is not in  $T$ , alter the input by changing the weight of  $e$  to 1. Rerun the algorithm. Notice that since the algorithm does not examine  $e$ , it will still output  $T$ . However, for the modified input,  $T$  is not a minimal spanning tree. This is a contradiction. Therefore every minimal spanning tree algorithm examines every edge in  $K_n$ .
15. True
17. The proof is similar to the proof of Theorem 9.4.5. Let  $G_i$  be the graph produced at the  $i$ th iteration. Use induction to show that  $G_i$  contains a minimal spanning tree.
18. Change  $\infty$  in line 6 to  $-\infty$ . Change  $<$  to  $>$  in line 10.
21. (For Exercise 1) If we break ties by picking the smallest vertices, Kruskal's Algorithm picks, successively,  $(2, 3)$ ,  $(3, 5)$ ,  $(3, 4)$ ,  $(1, 2)$ .
22. Argue as in the proof of Theorem 9.4.5.
24. The algorithm picks one 10-cent stamp and six 1-cent stamps to make 16 cents postage, but two 8-cent stamps is optimal.
25. We use induction on  $n$  to show that the greedy solution and any optimal solution to the  $n$ -cent problem are identical. The statement is clearly true for  $n = 1, 2, 3, 4, 5, 25$ .  
 Suppose that  $5 < n < 25$ . Let  $S$  be an optimal solution to the  $n$ -cent problem. We must use a 5-cent stamp; for otherwise, we could replace five 1-cent stamps with one 5-cent stamp. Now  $S$  with a 5-cent stamp removed is an optimal solution to the  $(n - 5)$ -cent problem; for otherwise, an optimal solution to the  $(n - 5)$ -cent problem together with a 5-cent stamp would be smaller than  $S$ . By the inductive assumption,  $S$ , with a 5-cent stamp removed, is the greedy solution. Therefore  $S$  is the greedy solution.  
 Suppose that  $n > 25$ . Let  $S$  be an optimal solution to the  $n$ -cent problem. We must use a 25-cent stamp since we can make at most 24 cents postage optimally using only 5-cent and 1-cent stamps. Now  $S$  with a 25-cent stamp removed is an optimal solution to the  $(n - 25)$ -cent problem. By the inductive assumption, it is the greedy solution. Therefore  $S$  is the greedy solution.
26.  $a_1 = 11$ ,  $a_2 = 5$ . For  $n = 15$ , the greedy method gives 11, 1, 1, 1, 1, but 5, 5, 5 is better.
28. The set  $\{1, 5, 11\}$  shows that the condition is not sufficient. For  $n = 15$ , the greedy algorithm gives one 11-cent stamp and four 1-cent stamps, but three 5-cent stamps is optimal.  
 The set  $\{1, 5, 10, 20, 25, 40\}$  shows that the condition is not necessary. (The example is due to Stephen B. Maurer, *Amer. Math. Mo.*, 101 (5), 419.) The greedy algorithm is optimal for these denominations; however, the condition fails for  $i = 5$ :  $25 \geq 2 \cdot 20 - 10$  is false.  
 We can use induction to prove that the greedy algorithm is optimal for the set  $\{1, 5, 10, 20, 25, 40\}$ . We verify directly the cases  $1 \leq n \leq 214$ . Now suppose that  $n > 214$ . Let  $S$  be an optimal solution for  $n$ . We claim that  $S$  contains a 40-cent stamp. If not,  $S$  contains at most four 1-cent stamps (since five 1-cent stamps could be replaced by one 5-cent stamp). For the same reason,

$S$  contains at most one 5-cent stamp, at most one 10-cent stamp, at most one 20-cent stamp, and at most seven 25-cent stamps. But now  $S$  can make at most

$$4 \cdot 1 + 1 \cdot 5 + 1 \cdot 10 + 1 \cdot 20 + 7 \cdot 25 = 214$$

cents postage. This contradiction shows that  $S$  contains a 40-cent stamp.

Now let  $G_n$  be the greedy solution for  $n$ -cents postage, and let  $S'$  be  $S$  with one 40-cent stamp removed. Then  $S'$  is optimal for  $(n - 40)$ -cents postage. By the inductive assumption,  $|G_{n-40}| = |S'|$ . Therefore

$$|G_n| = 1 + |G_{n-40}| = 1 + |S'| = |S|,$$

and the greedy solution is optimal for  $n$ -cents postage.

30. Let  $a_1 = 1$ ,  $a_2 = 5$ , and  $a_3 = 6$ . The greedy algorithm is optimal for  $n = 1, \dots, 9$ , but not optimal for  $n = 10$ .

## Section 9.5

2. Input:  $root$ , the root of an  $n$ -vertex binary search tree;  $key$ , a value to find; and  $n$   
 Output: The vertex containing  $key$ , or null if  $key$  is not in the tree

```

bst_search(root, n, key) {
 ptr = root
 while (ptr \neq null)
 if (ptr contains key)
 return ptr
 else if (ptr contains a value greater than key)
 ptr = left child of ptr
 else
 ptr = right child of ptr
 return null
}

```

3. Input:  $s_1, \dots, s_n; n$   
 Output: A binary search tree  $T$  of minimum height that stores the input

```

optimal_bst(s, n) {
 sort s_1, \dots, s_n
 return o_bst(s, 1, n)
}

```

```

o_bst(s, i, j) {
 if (i > j)
 return null
 m = [(i + j)/2]
 T' = optimal_bst(s, i, m - 1)
 T'' = optimal_bst(s, m + 1, j)
 let T be the tree whose root contains sm
 let the left subtree of T be T'
 let the right subtree of T be T''
 return T
}

```

6. There is no such graph. The existence of such a graph would contradict Theorem 9.5.6.

7.

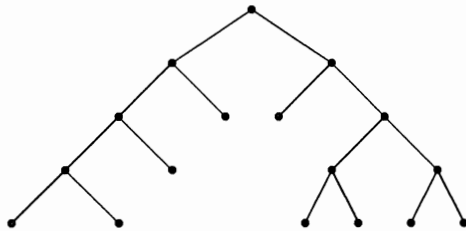

9. Input: An integer  $n > 1$   
 Output: A full binary tree  $T$  with  $n$  terminal vertices

```

full_binary_tree(n) {
 T = a rooted tree with one vertex
 for i = 1 to n - 1 {
 let v be a terminal vertex
 give v two children
 }
 return T
}

```

10. Input: A word  $w$  to insert in a binary search tree  $T$   
 Output: The updated binary search tree  $T$

```

bst_rekurs(w, T)
 if (T == null) {
 let T be the tree with one vertex, root
 store w in root
 return T
 }
 s = word in T's root
 if (w < s)
 if (T has no left child)
 give T a left child and store w in it

```

```

 else {
 left = left child of T
 bst_rekurs(w , left)
 }
else
 if (T has no right child)
 give T a right child and store w in it
 else {
 right = right child of T
 bst_rekurs(w , right)
 }
return T
}

```

12. Input: The root  $root$  of a nonempty binary tree in which data are stored
- Output: true, if the binary tree is a binary search tree; false, if the binary tree is not a binary search tree. If the binary tree is a binary search tree, the algorithm sets  $small$  to the smallest value in the tree and  $large$  to the largest value in the tree.

```

is_bst($root$, $small$, $large$) {
 if ($root$ has no children) {
 $small$ = value of $root$
 $large$ = value of $root$
 return true
 }
 $lchild$ = left child of $root$
 $rchild$ = right child of $root$
 if ($is_bst(lchild, small_left, large_left) \wedge is_bst(rchild, small_right, large_right)$) {
 val = value of $root$
 if ($large_left > val \vee small_right < val$)
 return false
 $small$ = $small_left$
 $large$ = $large_right$
 return true
 }
 else
 return false
}

```

13. We prove the result using induction on  $n$ .

**Basis Step** ( $n = 1$ ). In this case, the tree consists of three vertices—the root and its two children. Thus  $I = 0$ ,  $E = 2$ , and  $E = 2 = 0 + 2 \cdot 1 = I + 2n$ .

**Inductive Step.** Assume that the equation is true for  $n$ . Let  $T$  be a tree with  $n + 1$  internal vertices. Let  $T'$  be the tree obtained from  $T$  by deleting two sibling terminal vertices and the edges incident on them. Let  $p$  denote the (former) parent of the deleted siblings. The resulting tree  $T'$  has  $n$  internal vertices. Let  $I'$  and  $E'$  denote the internal and external path lengths for  $T'$ . By the inductive assumption,  $E' = I' + 2n$ .

If  $len$  denotes the length of the simple path from the root to  $p$  in  $T$ , the external path length in  $T$  is obtained from the external path length in  $T'$  by adding  $2(len + 1)$ , to account for the two new paths to the children of  $p$ , and by subtracting  $len$ , to account for the loss of the path to the former terminal  $p$ ; thus,

$$E = E' + 2(len + 1) - len = I' + 2n + len + 2.$$

The internal path length in  $T'$  is obtained from the internal path length in  $T$  by subtracting  $len$  to account for the loss of the path to  $p$ ; thus,

$$E = I' + 2n + len + 2 = I - len + 2n + len + 2 = I + 2(n + 1).$$

15. Balanced

16. Not balanced

19. If the balanced trees of heights  $h - 1$  and  $h - 2$  with the minimum number of vertices are found, the required tree of height  $h$  can be formed by attaching these two trees as right and left subtrees of a new root. Thus  $N_h = N_{h-1} + N_{h-2} + 1$ .

20. Let  $s_h = N_h + 1$ . Then

$$s_h = N_h + 1 = 1 + N_{h-1} + N_{h-2} + 1 = s_{h-1} + s_{h-2},$$

by Exercise 19. Now  $s_0 = N_0 + 1 = 2$ ,  $s_1 = N_1 + 1 = 3$  (Exercise 18). Thus  $\{s_h\}$  satisfies the same recurrence relation as the Fibonacci sequence. Since  $s_0 = f_3$  and  $s_1 = f_4$ , it follows that  $s_h = f_{h+3}$ ,  $h \geq 0$ . Therefore  $N_h = s_h - 1 = f_{h+3} - 1$ .

22. We prove that  $n < 2^{h+1}$  using induction on  $n$ . Taking  $\lg$  of both sides gives the desired result. We omit the Basis Step ( $n = 1$ ).

Assume that the result is true for binary trees with less than  $n$  vertices. Let  $T$  be an  $n$ -vertex binary tree. Let  $n_L$  be the number of vertices in  $T$ 's left subtree, and let  $n_R$  be the number of vertices in  $T$ 's right subtree. Let  $h_L$  be the height of  $T$ 's left subtree, and let  $h_R$  be the height of  $T$ 's right subtree. Note that  $1 + h_L \leq h$  and  $1 + h_R \leq h$ . By the inductive assumption,  $n_L < 2^{h_L+1}$  and  $n_R < 2^{h_R+1}$ . Now

$$n = 1 + n_L + n_R < 1 + 2^{h_L+1} + 2^{h_R+1} \leq 1 + 2^h + 2^h = 1 + 2 \cdot 2^h = 1 + 2^{h+1}.$$

## Section 9.6

2. Preorder:  $ABCDEF$   
 Inorder:  $CBEFDA$   
 Postorder:  $CFEDBA$

3. Preorder: *ABHIKLMJCDEFG*  
 Inorder: *ILKMHJBADFEGC*  
 Postorder: *LMKIJHBFGECDCA*
5. Preorder: *ABCDEFGH*  
 Inorder: *DCBAEFGH*  
 Postorder: *DCBGFEA*
7. Prefix: */\*-ACD+A-BD*  
 Postfix: *AC-D\*ABD-+ /*

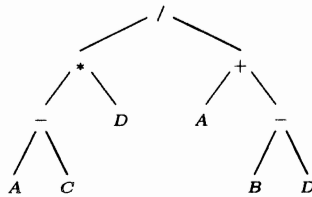

8. Prefix: *-+\*AB\*CD-/AB+DE*  
 Postfix: *AB\*CD\*+AB/DE+--*

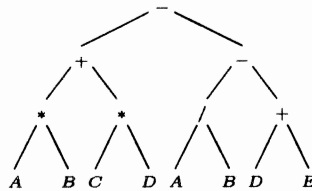

10. Prefix: *++-\*AB/CDE/- - -ABC\*DD++ABC*  
 Postfix: *AB\*CD/-E+AB-C-DD\*-AB+C+ / +*

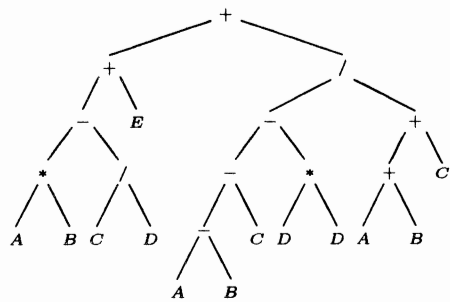

12. Prefix: *-A+BC*  
 Usual Infix: *A-(B+C)*  
 Parened Infix: *(A-(B+C))*

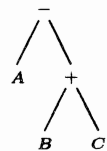

13. Prefix: *-/A\*B+CDE*  
 Usual Infix: *A/(B\*(C+D))-E*  
 Parened Infix: *((A/(B\*(C+D)))-E)*

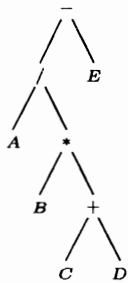

15. Prefix:  $*-+AB-*CD/EFA$   
 Usual Infix:  $(A+B-(C*D-E/F))*A$   
 Parened Infix:  $((A+B)-((C*D)-(E/F)))*A$

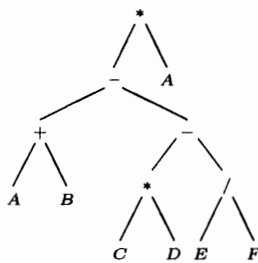

17. 0      18. -16      20. 16      21. -6

23. The tree is



Because of the preorder listing,  $A$  is the root. If  $A$  had a left child, the inorder listing would not begin with  $A$ . Since  $A$  has no left child, the preorder listing tells us that the right child of  $A$  is  $B$ . The argument that the tree is correct continues in this way.

24. Input:  $pr$ , the preorder list, and  $in$ , the inorder list  
 Output:  $root$ , the root of the binary tree with the given preorder and inorder lists

```
make_tree(pr, in) {
 if (|pr| == 0)
 return null
 ch = first character in pr
 create a vertex v
 store ch in v
 root = v
```

```

choose strings $st1$ and $st2$ such that $in = st1 + ch + st2 // +$ is concatenation
let pr' be the substring of pr obtained by omitting ch
choose strings $st1'$ and $st2'$ such that $pr' = st1 + st2'$, where $st1'$ (respectively, $st2'$) is a
 permutation of $st1$ (respectively, $st2$)
left subtree of $root = make_tree(st1', st1)$
right subtree of $root = make_tree(st2', st2)$
return $root$
}

```

26. Not necessarily. Consider  $P_1 = ABCDEF$  and  $P_2 = DBCAEF$ .

27. Input:  $pt$ , the root of a binary tree  
Output: contents of the terminal vertices from left to right

```

print_terminals(pt) {
 if ($pt == null$)
 return
 if (pt is a terminal) {
 print contents of pt
 return
 }
 $left =$ left child of pt
 print_terminals($left$)
 $right =$ right child of pt
 print_terminals($right$)
}

```

29. Input:  $pt$ , the root of a binary tree  
Output: initialize each vertex to the number of its descendants

```

descendants(pt) {
 if ($pt == null$)
 return
 $numb_desc = 0$
 $left =$ left child of pt
 if ($left \neq null$) {
 descendants($left$)
 $numb_desc = 1 + contents(left)$
 }
 $right =$ right child of pt
 if ($right \neq null$) {
 descendants($right$)
 $numb_desc = numb_desc + 1 + contents(right)$
 }
 contents(pt) = $numb_desc$
}

```



31. Input:  $pt$ , the root of a binary tree that represents an expression  
 Output: the fully parenthesized infix form of the expression

```

print_expression(pt)
 if (pt == null)
 return
 if (pt is a terminal) {
 print(contents(pt))
 return
 }
 print("(")
 left = left child of pt
 print_expression(left)
 print(contents(pt))
 right = right child of pt
 print_expression(right)
 print(")")
}

```

32. Input:  $pt$ , the root of a Huffman coding tree, and a string  $\alpha$   
 Output: The characters and their codes. Each code is prefixed by  $\alpha$ .  
 To print just the codes, invoke this procedure with  $\alpha$  set to the null string.

```

huffman(pt, α)
 if (pt is a terminal) {
 print(character stored in pt)
 print(α)
 return
 }
 left = left child of pt
 huffman(left, $\alpha + 1$) // + is concatenation
 right = right child of pt
 huffman(right, $\alpha + 0$)
}

```

34. First, note that any subset of  $n - 1$  vertices is a vertex cover. Second, note that any subset  $V'$  of  $n - 2$  edges is *not* a vertex cover. [If  $v$  and  $w$  are distinct vertices not in  $V'$ , then edge  $(v, w)$  violates the condition that either  $v$  or  $w$  is in  $V'$ .]
35. No. Exercise 34 shows that even if *all* edges are present,  $n - 1$  vertices suffice for a cover.
37. Let  $E'$  be an edge disjoint set for  $G$ , and let  $V'$  be a vertex cover of  $G$ . We define a function  $f$  from  $E'$  to  $V'$  in the following way: Let  $e = (v, w) \in E'$ . Then either  $v$  or  $w$  is in  $V'$ . Choose one of  $v$  or  $w$  that is in  $V'$ , but not both, and let  $f(e)$  denote the chosen vertex. The function  $f$  is one-to-one because the set  $E'$  is an edge disjoint set. Therefore  $|E'| \leq |V'|$ .

38. The graph

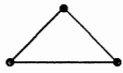

has the desired property since it is impossible to put more than one edge in an edge disjoint set and a single vertex is *not* a vertex cover.

### Section 9.7

2. A tree of height one has at most three terminal nodes. Since four outcomes are possible, the decision tree must have height at least two. Thus at least two weighings are required to solve the problem of Exercise 1.
3. In the following figure, if the coins in the left pan weigh less than the coins in the right pan, we go to the left child. If the coins in the left pan weigh more than the coins in the right pan, we go to the right child. If the coins in the left pan weigh the same as the coins in the right pan, we go to the middle child.

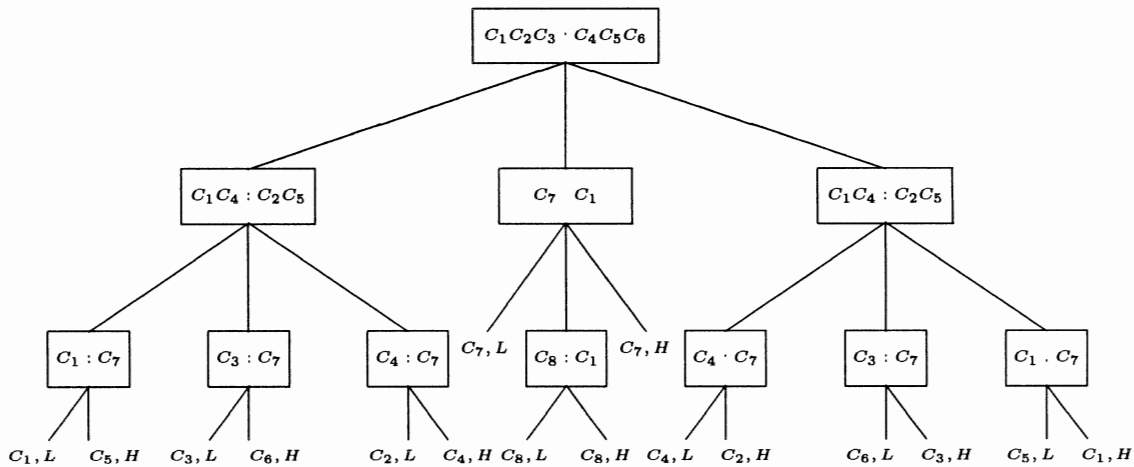

5. If we weigh four coins against four coins and they balance, the problem does *not* reduce to the problem of finding the bad coin from among four coins, but rather to the problem of finding the bad coin from among four coins and *eight good coins*. This latter problem can be solved in at most two weighings.
6. Four weighings are required in the worst case. We prove this result by considering several cases. Suppose that we begin by weighing four coins against four coins. If they balance, in two additional weighings, we can account for at most nine outcomes. Since ten outcomes are possible with five coins, we cannot identify the bad coin in at most three weighings in this case. Similarly, if we begin by weighing three coins against three coins, two coins against two coins, or one coin against one coin, at least four weighings are required in the worst case. Suppose that we begin by weighing five coins against five coins. Consider one of the instances in which they do not balance:

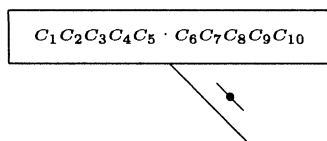

In two more weighings, we can account for at most nine outcomes, but there are ten

$$C_1, L, C_2, L, C_3, L, C_4, L, C_5, L, C_6, H, C_7, H, C_8, H, C_9, H, C_{10}, H.$$

Therefore, if we begin by weighing five coins against five coins, at least four weighings are required in the worst case.

Similarly, if we begin by weighing six coins against six coins, at least four weighings are required in the worst case.

We conclude that the 13-coins puzzle requires at least four weighings in the worst case. In fact, the puzzle can be solved in at most four weighings: Begin by weighing four coins against four coins. If they do not balance, proceed as in the solution to the 12-coins puzzle (see Exercise 4). If they balance, five coins remain. We can identify a bad coin among five in at most three weighings (see Example 9.7.1).

8. If there is an algorithm that solves the puzzle in  $k < n$  weighings, the algorithm can be described by a decision tree of height  $k$ . Every internal vertex of this tree has at most three children; thus, there can be at most  $3^k$  terminal vertices. But there are  $2((3^n - 3)/2) = 3^n - 3$  possible outcomes and  $3^n - 3 > 3^k$  for  $n \geq 2$ ,  $k < n$ , which is a contradiction.
9. Input:  $a_1, a_2, a_3, a_4$   
Output:  $a_1, a_2, a_3, a_4$  (in increasing order)

```

sort_4(a_1, a_2, a_3, a_4)
 // sort a_1 and a_2
 if ($a_1 > a_2$)
 swap(a_1, a_2)
 // sort a_3 and a_4
 if ($a_3 > a_4$)
 swap(a_3, a_4)
 // find largest
 if ($a_2 > a_4$)
 swap(a_2, a_4)
 // find smallest
 if ($a_1 > a_3$)
 swap(a_1, a_3)
 // sort a_2 and a_3
 if ($a_2 > a_3$)
 swap(a_2, a_3)
}

```

11. There are  $6! = 720$  possible outcomes to the problem of sorting six items. To accommodate 720 vertices, we must have a tree of height at least 10 since  $2^9 < 720 < 2^{10}$ . Thus we need 10 comparisons in the worst case.

To sort six items using at most 10 comparisons, we first sort five items using an optimal sort (see Exercise 10). This requires at most seven comparisons. We then find the correct position for the sixth item using binary search. This last step requires at most three comparisons.

13.

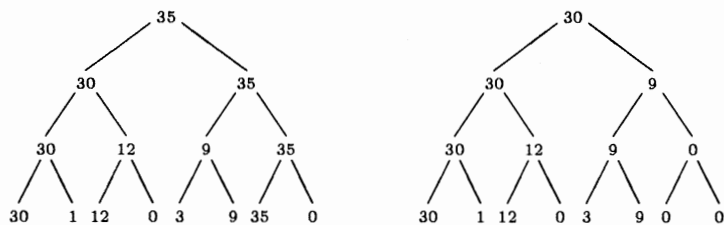

14.  $2^k - 1$

16.  $k$

### Section 9.8

2. Not isomorphic. Tree  $T_2$  has a vertex of degree 4 ( $w_4$ ), but  $T_1$  has no vertex of degree 4.
3. Isomorphic.  $f(v_1) = w_3, f(v_2) = w_5, f(v_3) = w_6, f(v_4) = w_2, f(v_5) = w_1, f(v_6) = w_4$ .
5. Not isomorphic. Vertex  $v_{10}$  in  $T_1$  must be mapped to vertex  $w_4$  in  $T_2$  since these are the only vertices of degree 4. The vertices adjacent to  $v_{10}$  have degree 1, 1, 2, 3, while the vertices adjacent to  $w_4$  have degree 1, 2, 3, 2.
6. Isomorphic.  $f(v_1) = w_7, f(v_2) = w_4, f(v_3) = w_6, f(v_4) = w_{10}, f(v_5) = w_3, f(v_6) = w_2, f(v_7) = w_9, f(v_8) = w_{11}, f(v_9) = w_1, f(v_{10}) = w_8, f(v_{11}) = w_5, f(v_{12}) = w_{12}$ .
8. Not isomorphic as rooted trees. The root of  $T_1$  has degree 3, but the root of  $T_1$  has degree 1. They are isomorphic as free trees (see the solution to Exercise 3).
9. Isomorphic.  $f(v_i) = w_i, i = 1, \dots, 5$ . Also, they are isomorphic as free trees.
11. Isomorphic.  $f(v_i) = w_i, i = 1, \dots, 6$ . Also, they are isomorphic as rooted trees and as free trees.
12. Not isomorphic. The root of  $T_1$  has no right child, but the root of  $T_2$  has a right child. They are not isomorphic as rooted trees, but they are isomorphic as free trees.

14.

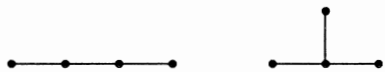

15.

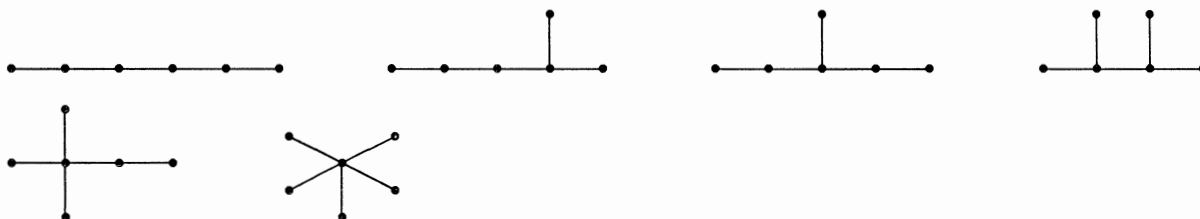

17.

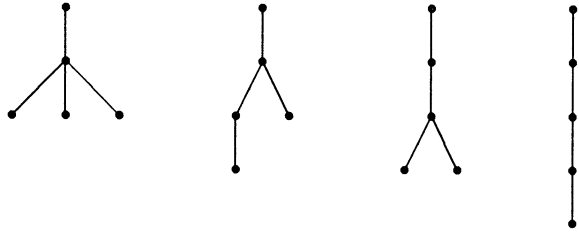
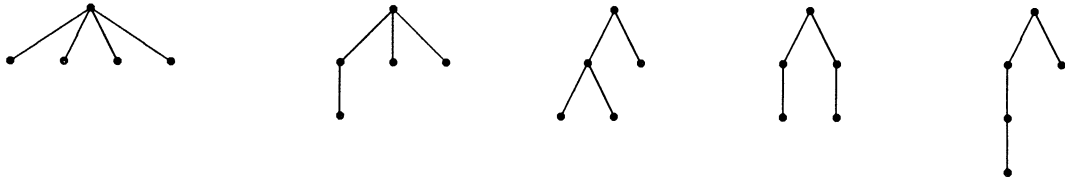

18.

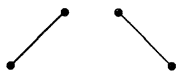

20.

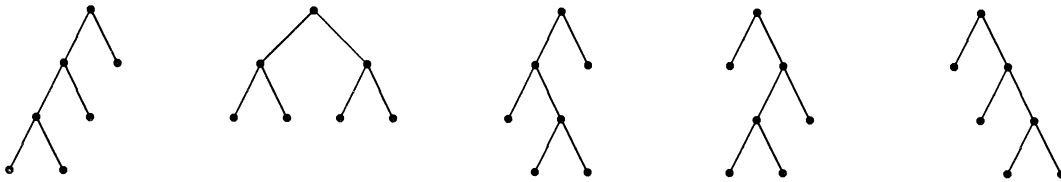

21.

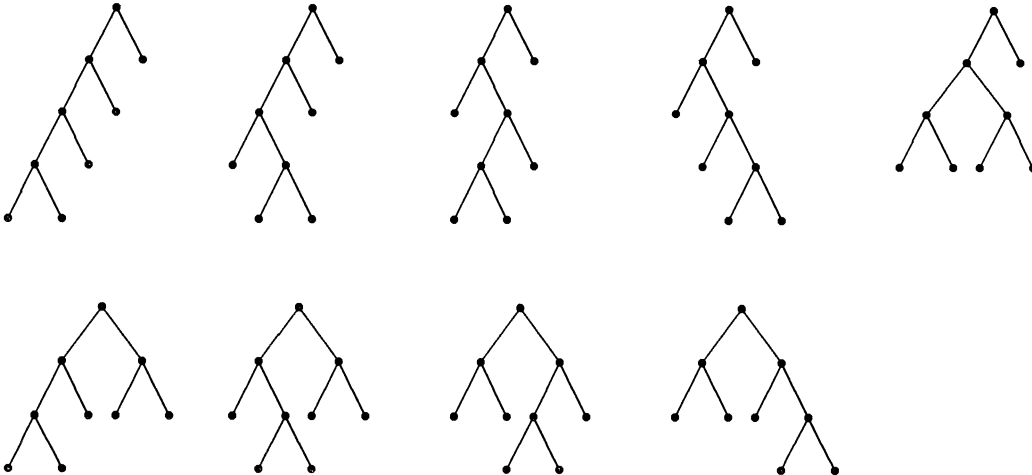

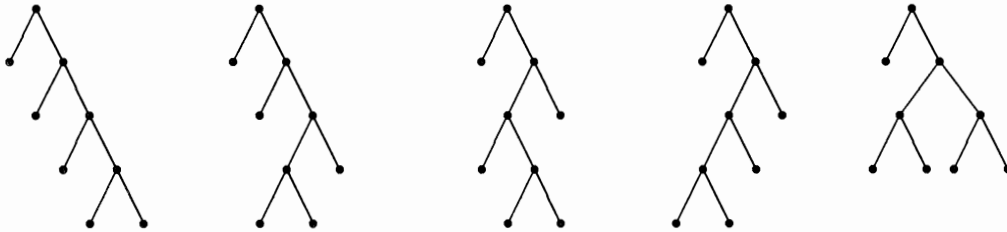

23. For Exercise 9, there are 10 spanning trees obtained by replacing the left triangle by

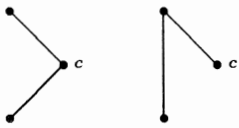

and by replacing the leftmost figure by



24. Let  $b_k$  denote the number of comparisons when two  $k$ -vertex isomorphic binary trees are input to Algorithm 9.8.13. We use induction on  $k$  to show that

$$b_k = 6k + 2. \tag{9.1}$$

If  $k = 0$ , the trees are empty. In this case, there are two comparisons at line 1 after which the procedure returns. Thus (9.1) is correct for  $k = 0$ .

Assume that

$$b_i = 6i + 2$$

for  $i < k$ . There are four comparisons at lines 1 and 3. Let  $L$  denote the number of vertices in the left subtree (of either tree) and  $R$  denote the number of vertices in the right subtree (of either tree). By the inductive assumption, line 9 requires

$$b_L + b_R = (6L + 2) + (6R + 2)$$

comparisons. Thus the total number of comparisons is

$$4 + 6L + 2 + 6R + 2 = 6(1 + L + R) + 2 = 6k + 2.$$

The inductive step is complete.

26. Input:  $n$   
 Output: an  $n$ -vertex random binary tree

```

rand_bin_tree(n) {
 if (n == 0)
 return null
 let k be a random integer between 0 and n - 1 inclusive
 T1 = rand_bin_tree(k)
 T2 = rand_bin_tree(n - 1 - k)
 let T be the binary tree with left subtree T1 and right subtree T2
 return T
}

```

27. The hint provides a one-to-one correspondence between  $n$ -edge ordered trees and strings of  $n$  zeros and  $n$  ones in which, reading from the left, the number of ones is always greater than or equal to the number of zeros. The number of such strings is  $C_n$ , since these strings also encode paths in an  $n \times n$  grid from the lower-left corner to the upper-right corner that never go above the diagonal from the lower-left corner to the upper-right corner (see Example 7.1.7). The encoding is obtained by interpreting a one as a move right and a zero as a move up.

### Section 9.9

2. The second player always wins. If the first player leaves  $\{1, 3\}$  or  $\{0, 3\}$ , leave one. If the first player leaves  $\{2, 3\}$ , leave  $\{2, 2\}$ . After the first player moves, the second player can leave one. Part of the tree is

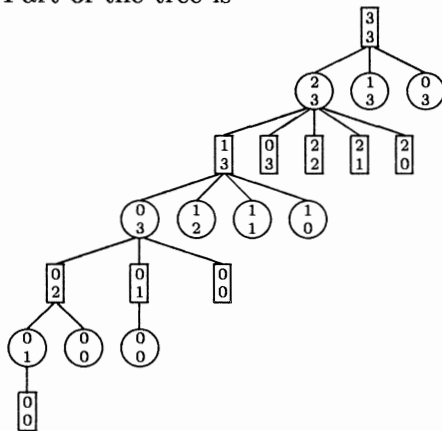

3. The tree is the same as Figure 9.9.1. The terminal vertices are assigned values as in Figure 9.9.2 with 0 and 1 interchanged. After applying the minimax procedure, the root receives the value 1; thus the first player will always win. The optimal strategy is to first leave  $\{2, 2\}$ . If the second player leaves only one pile, take it; otherwise, leave  $\{1, 1\}$ .
5. The tree is the same as in Exercise 1. The terminal vertices are assigned values as in the hint for Exercise 1 with 0 and 1 interchanged. After applying the minimax procedure, the root receives the value 1; thus the first player will always win. The optimal strategy is take 2. No matter how many player 2 chooses, player 1 can take the rest.
6. Figure 9.9.2

8. The strategy for winning play is: Play nim' exactly like nim unless the move would leave an odd number of singleton piles and no other pile. In this case, leave an even number of piles.

10.

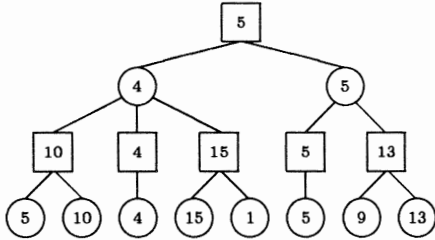

11. The value of the root is 10.

13. The value of the root is 9.

16.  $4 - 2 = 2$             17.  $1 - 1 = 0$

20. No. Assign a larger value to a winning position.

21.    Input:    the root  $pt$  of a game tree, the level  $pt\_level$  of  $pt$ , the maximum level  $n$  to which the search is to be conducted, and an evaluation function  $E$   
          Output: the game tree with the values of the vertices stored in the vertices

```

minimax(pt, pt_level, n, E) {
 if ($pt_level == n$) {
 $contents(pt) = E(pt)$
 return
 }
 let c_1, \dots, c_k be the children of pt
 for $i = 1$ to k {
 $minimax(c_i, pt_level + 1, n, E)$
 $e_i = contents(c_i)$
 }
 if (pt is a box vertex)
 $contents(pt) = \max\{e_1, \dots, e_k\}$
 else
 $contents(pt) = \min\{e_1, \dots, e_k\}$
}

```

24. We first obtain the values 9, 6, 7 for the children of the root. Thus we order the children of the root 9, 7, 6 and use alpha-beta pruning to obtain



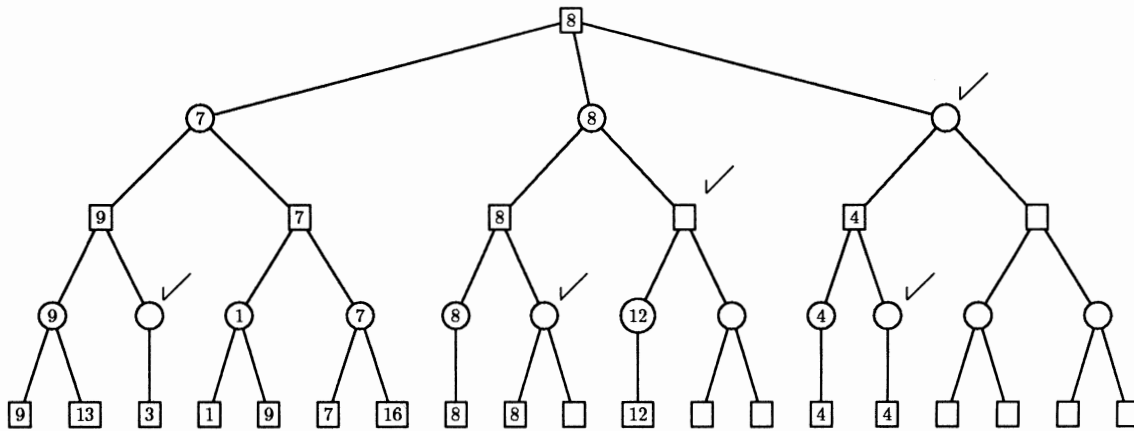

29–30. It is possible to always force a draw in Mu Torere, see P. D. Straffin, Jr., “Position graphs for Pong Hau K’i and Mu Torere,” *Math. Mag.*, 68 (1995), 382–386, and “Corrected figure for position graphs for Pong Hau K’i and Mu Torere,” *Math. Mag.*, 69 (1996), 65.



# Chapter 10

## Solutions to Selected Exercises

### Section 10.1

2.  $(a, d)$ -1,  $(b, d)$ -2,  $(e, c)$ -2,  $(e, z)$ -1. The value of the flow is 5.

3.  $(a, b)$ -3,  $(a, d)$ -1,  $(d, c)$ -0,  $(d, f)$ -1,  $(c, e)$ -1,  $(g, z)$ -2,  $(c, z)$ -2. The value of the flow is 6.

5.

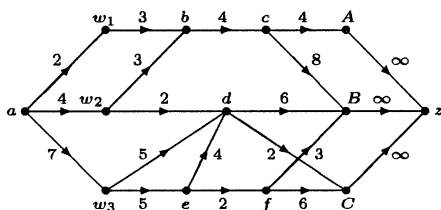

6. Make the capacities of  $(A, z)$ ,  $(B, z)$ , and  $(C, z)$ , 4, 3, and 4, respectively.

8.

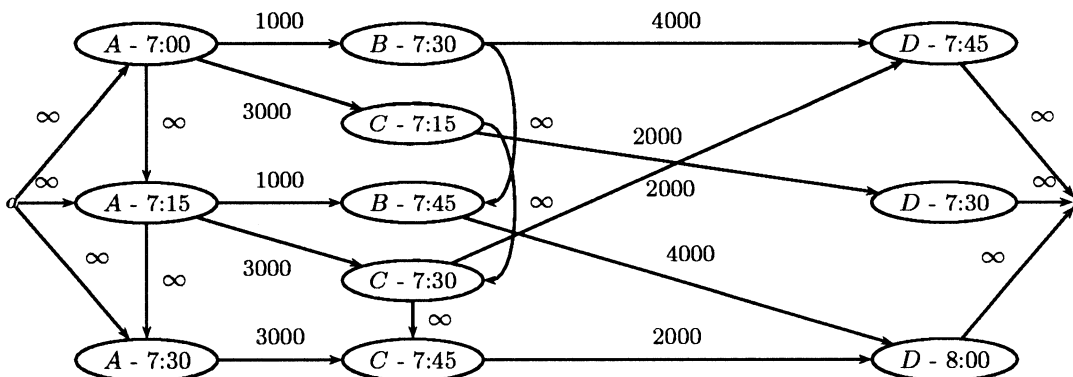

9. Replace each undirected edge by two directed edges



each having weight equal to the weight of the undirected edge.

11.  $n^2 - 3n + 3$ . To prove this, we sum the in and out degrees of the vertices and then divide by 2. The source has  $n - 1$  out edges. The sink has  $n - 1$  in edges. All other vertices have  $n - 2$

out edges (since an edge cannot go to itself or the source) and  $n - 2$  in edges (since an edge cannot come from itself or the sink). Since there are  $n - 2$  vertices besides the sink and source, the sum of the in and out degrees is

$$(n - 1) + (n - 1) + (n - 2)[(n - 2) + (n - 2)] = 2n^2 - 6n + 6.$$

We obtain  $n^2 - 3n + 3$  by dividing by 2.

### Section 10.2

2. 2      3. 1

5.

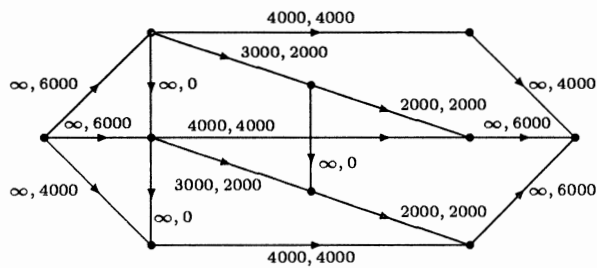

6.

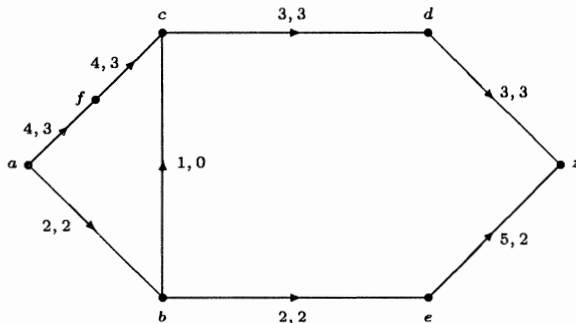

8.

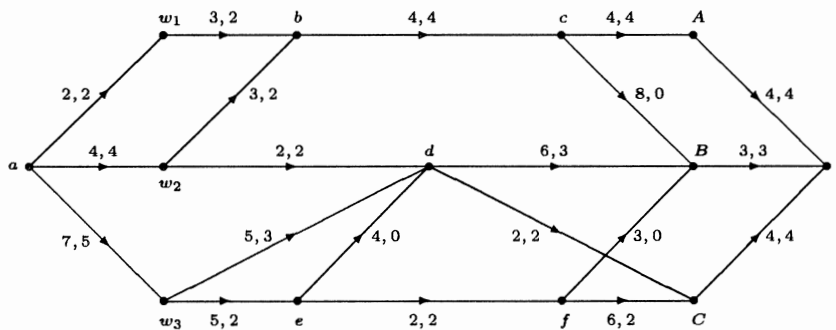

9.

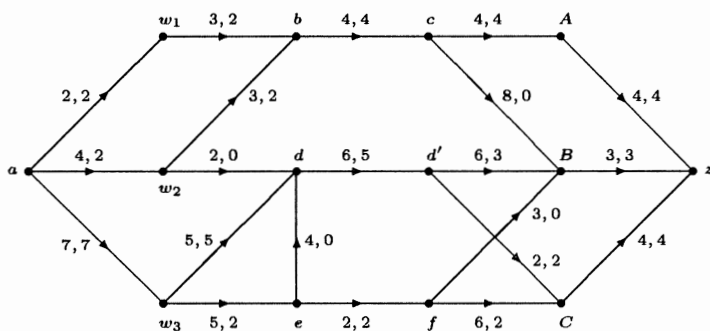

11.

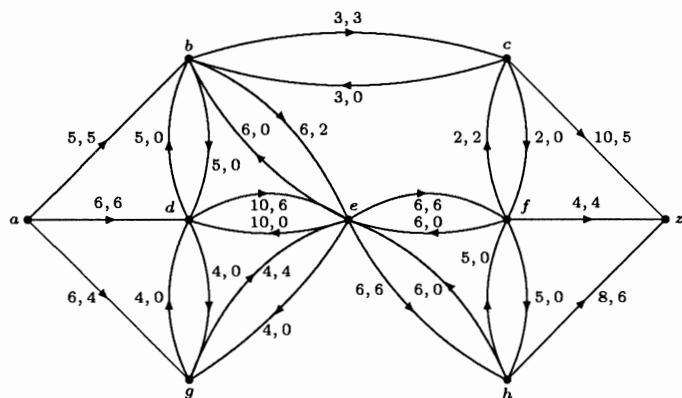

12.  $(a, b)$ -10,  $(a, f)$ -11,  $(a, j)$ -1,  $(b, c)$ -6,  $(b, g)$ -9,  $(f, b)$ -5,  $(f, g)$ -6,  $(j, g)$ -1,  $(c, d)$ -8,  $(c, h)$ -2,  $(g, c)$ -4,  $(g, h)$ -12,  $(d, e)$ -8,  $(h, i)$ -6,  $(h, n)$ -6,  $(h, m)$ -2,  $(m, n)$ -2,  $(e, z)$ -8,  $(i, z)$ -6,  $(n, z)$ -8. All other edges have flow equal to 0.

14. 8

15.

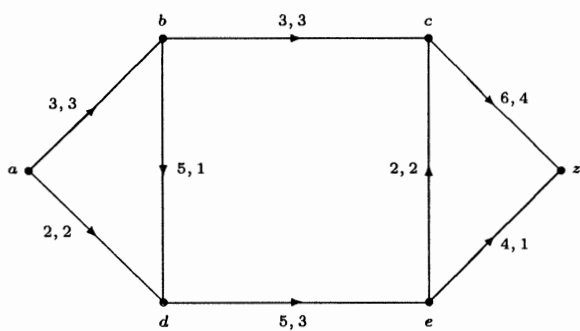

17.

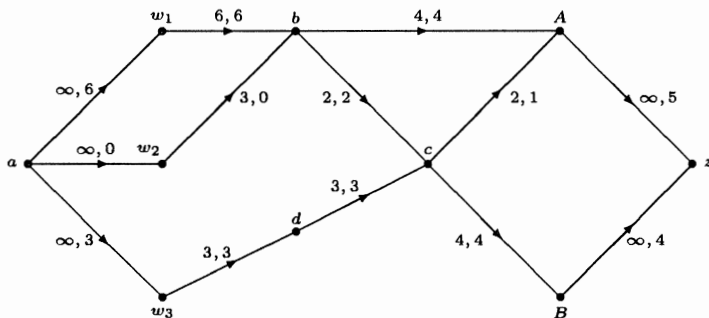

18.  $(a, w_1)$ -3,  $(a, w_2)$ -3,  $(a, w_3)$ -3,  $(w_1, b)$ -3,  $(w_2, b)$ -3,  $(w_3, d)$ -3,  $(b, A)$ -4,  $(b, c)$ -2,  $(d, c)$ -3,  $(c, A)$ -2,  $(c, B)$ -3,  $(A, z)$ -6,  $(B, z)$ -3

### Section 10.3

2. 9; not minimal

3. 15; not minimal

5.  $P = \{a, w_1, w_2, w_3, b, d\}$ 6.  $P = \{a, A-6:00, B-6:15, A-6:15, B-6:30, A-6:30\}$ 8.  $P = \{a\}$ 9.  $P = \{a, b\}$ 11.  $P = \{a\}$ 12.  $P = \{a, w_1, w_2, w_3, b, c, d, e, f, A, B, C\}$ 14.  $P = \{a, A-7:00, C-7:15, A-7:15, C-7:30, A-7:30, C-7:45\}$ 15.  $P = \{a, b, d, e, g\}$ 

19. Use Exercise 18 and imitate the proofs of Theorems 10.3.7 and 10.3.9.

21. The argument is similar to that of Exercise 19.

22. Modify Algorithm 10.2.4.

Section 10.4

2. A minimal cut is  $P = \{a\}$ .

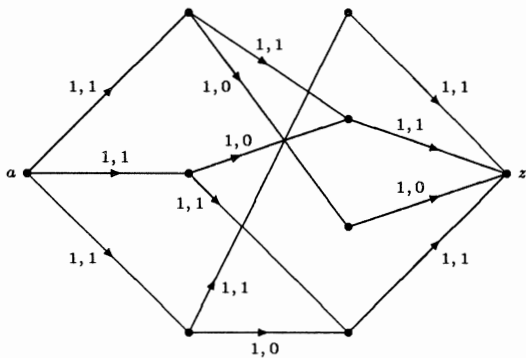

4. Filling the maximum number of jobs

5.  $J_1 - C, J_2 - A, J_5 - D$

7. There is not a complete matching because there are fewer persons than jobs.

8.

(a)(b)

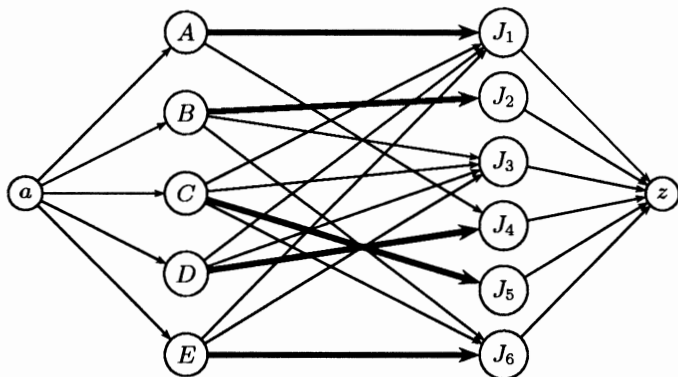

(c) Yes

11.

(a)(d)

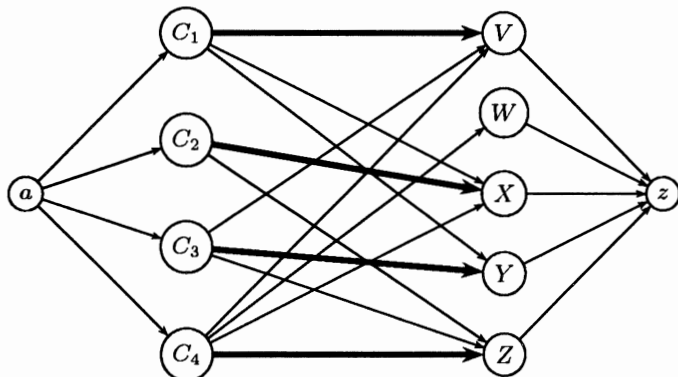

- (b) The maximum number of committees that can be represented
- (c) All committees are represented.
- (e) Yes

12. Let  $V = \{v_1, \dots, v_m\}$  and  $W = \{w_1, \dots, w_n\}$  be the disjoint vertex sets. Order the vertices

$$v_1, \dots, v_m, w_1, \dots, w_n.$$

- 14. Each row has exactly one label and each column has at most one label.
- 15. Among all labelings in which every column has at most one label, the maximum number of rows are labeled.
- 16. See A. Tucker, *Applied Combinatorics*, Wiley, New York, 1980, page 348.
- 18. See C. L. Liu, *Introduction to Combinatorial Mathematics*, McGraw-Hill, New York, 1968.
- 19. False. Consider

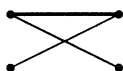

### Problem-Solving Corner: Matching

1.

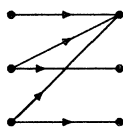



## Chapter 11

# Solutions to Selected Exercises

### Section 11.1

2.

| $x_1$ | $x_2$ | $\overline{\overline{x_1 \vee x_2}}$ |
|-------|-------|--------------------------------------|
| 1     | 1     | 0                                    |
| 1     | 0     | 1                                    |
| 0     | 1     | 0                                    |
| 0     | 0     | 0                                    |

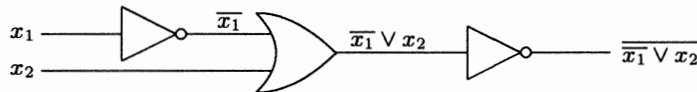

3.

| $x_1$ | $x_2$ | $x_3$ | $(x_1 \wedge x_2) \vee \overline{x_3}$ |
|-------|-------|-------|----------------------------------------|
| 1     | 1     | 1     | 1                                      |
| 1     | 1     | 0     | 1                                      |
| 1     | 0     | 1     | 0                                      |
| 1     | 0     | 0     | 1                                      |
| 0     | 1     | 1     | 0                                      |
| 0     | 1     | 0     | 1                                      |
| 0     | 0     | 1     | 0                                      |
| 0     | 0     | 0     | 1                                      |

5.

| $x_1$ | $x_2$ | $x_3$ | $x_4$ | $((\overline{x_1} \vee x_2) \wedge (\overline{x_3} \vee x_4)) \wedge (\overline{x_2} \vee x_4)$ |
|-------|-------|-------|-------|-------------------------------------------------------------------------------------------------|
| 1     | 1     | 1     | 1     | 1                                                                                               |
| 1     | 1     | 1     | 0     | 0                                                                                               |
| 1     | 1     | 0     | 1     | 1                                                                                               |
| 1     | 1     | 0     | 0     | 0                                                                                               |
| 1     | 0     | 1     | 1     | 0                                                                                               |
| 1     | 0     | 1     | 0     | 0                                                                                               |
| 1     | 0     | 0     | 1     | 0                                                                                               |
| 1     | 0     | 0     | 0     | 0                                                                                               |
| 0     | 1     | 1     | 1     | 1                                                                                               |
| 0     | 1     | 1     | 0     | 0                                                                                               |
| 0     | 1     | 0     | 1     | 1                                                                                               |
| 0     | 1     | 0     | 0     | 0                                                                                               |
| 0     | 0     | 1     | 1     | 1                                                                                               |
| 0     | 0     | 1     | 0     | 0                                                                                               |
| 0     | 0     | 0     | 1     | 1                                                                                               |
| 0     | 0     | 0     | 0     | 1                                                                                               |

6.

| $x_1$ | $x_2$ | $x_3$ | $x_4$ | $\overline{((x_1 \wedge x_2) \wedge (\overline{x_3} \vee x_4)) \vee (x_1 \wedge x_2)}$ |
|-------|-------|-------|-------|----------------------------------------------------------------------------------------|
| 1     | 1     | 1     | 1     | 1                                                                                      |
| 1     | 1     | 1     | 0     | 1                                                                                      |
| 1     | 1     | 0     | 1     | 1                                                                                      |
| 1     | 1     | 0     | 0     | 1                                                                                      |
| 1     | 0     | 1     | 1     | 0                                                                                      |
| 1     | 0     | 1     | 0     | 0                                                                                      |
| 1     | 0     | 0     | 1     | 0                                                                                      |
| 1     | 0     | 0     | 0     | 0                                                                                      |
| 0     | 1     | 1     | 1     | 0                                                                                      |
| 0     | 1     | 1     | 0     | 0                                                                                      |
| 0     | 1     | 0     | 1     | 0                                                                                      |
| 0     | 1     | 0     | 0     | 0                                                                                      |
| 0     | 0     | 1     | 1     | 0                                                                                      |
| 0     | 0     | 1     | 0     | 0                                                                                      |
| 0     | 0     | 0     | 1     | 0                                                                                      |
| 0     | 0     | 0     | 0     | 0                                                                                      |

8. If  $x = 0$ , the output of the AND gate is 0 regardless of the value of the other input. Thus the output of the NOT gate is 1. Therefore,  $y = 1$ .
9. Suppose that  $x = 1$  and  $y = 0$ . Then the input to the AND gate is 1, 0. Thus the output of the AND gate is 0. Since this is then NOTed,  $y = 1$ . Contradiction. Similarly, if  $x = 1$  and  $y = 1$ , we obtain a contradiction.

11. 1

12. 1

14. 1

15. (For Exercise 10)  $x_1$  and  $x_2$  are Boolean expressions by (11.1.2);  $x_1 \wedge x_2$  is a Boolean expression by (11.1.3d);  $\overline{x_1 \wedge x_2}$  is a Boolean expression by (11.1.3b).

17. Is a Boolean expression

18. Is a Boolean expression

20. Is a Boolean expression

21. The circuit for Exercise 10 is Exercise 1. The solution to Exercise 1 gives the logic table.

23.

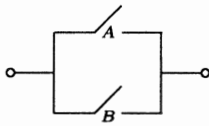

26.  $A \wedge (B \vee (C \wedge \overline{B}))$

27.  $(A \wedge (B \vee C)) \vee \overline{D}$

29.  $A \wedge ((B \vee \overline{D}) \vee (C \wedge (A \vee D \vee \overline{C}))) \wedge B$

31.

| A | B | C | $A \vee (\overline{B} \wedge C)$ |
|---|---|---|----------------------------------|
| 1 | 1 | 1 | 1                                |
| 1 | 1 | 0 | 1                                |
| 1 | 0 | 1 | 1                                |
| 1 | 0 | 0 | 1                                |
| 0 | 1 | 1 | 0                                |
| 0 | 1 | 0 | 0                                |
| 0 | 0 | 1 | 1                                |
| 0 | 0 | 0 | 0                                |

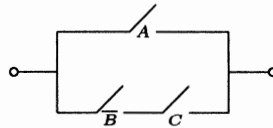

32.

| A | B | C | $(\overline{A} \wedge B) \vee (C \wedge A)$ |
|---|---|---|---------------------------------------------|
| 1 | 1 | 1 | 1                                           |
| 1 | 1 | 0 | 0                                           |
| 1 | 0 | 1 | 1                                           |
| 1 | 0 | 0 | 0                                           |
| 0 | 1 | 1 | 1                                           |
| 0 | 1 | 0 | 1                                           |
| 0 | 0 | 1 | 0                                           |
| 0 | 0 | 0 | 0                                           |

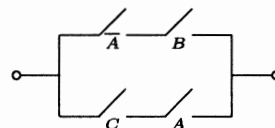

34.

| $A$ | $B$ | $C$ | $D$ | $A \wedge ((B \wedge C \wedge \bar{D}) \vee ((\bar{B} \wedge C) \vee D) \vee (\bar{B} \wedge \bar{C} \wedge D)) \wedge (B \vee \bar{D})$ |
|-----|-----|-----|-----|------------------------------------------------------------------------------------------------------------------------------------------|
| 1   | 1   | 1   | 1   | 1                                                                                                                                        |
| 1   | 1   | 1   | 0   | 1                                                                                                                                        |
| 1   | 1   | 0   | 1   | 1                                                                                                                                        |
| 1   | 1   | 0   | 0   | 0                                                                                                                                        |
| 1   | 0   | 1   | 1   | 0                                                                                                                                        |
| 1   | 0   | 1   | 0   | 1                                                                                                                                        |
| 1   | 0   | 0   | 1   | 0                                                                                                                                        |
| 1   | 0   | 0   | 0   | 0                                                                                                                                        |
| 0   | 1   | 1   | 1   | 0                                                                                                                                        |
| 0   | 1   | 1   | 0   | 0                                                                                                                                        |
| 0   | 1   | 0   | 1   | 0                                                                                                                                        |
| 0   | 1   | 0   | 0   | 0                                                                                                                                        |
| 0   | 0   | 1   | 1   | 0                                                                                                                                        |
| 0   | 0   | 1   | 0   | 0                                                                                                                                        |
| 0   | 0   | 0   | 1   | 0                                                                                                                                        |
| 0   | 0   | 0   | 0   | 0                                                                                                                                        |

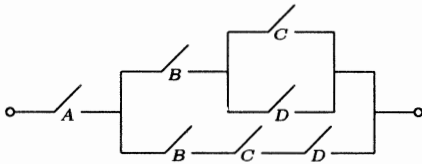

## Section 11.2

2.

| $x_1$ | $x_2$ | $(x_1 \wedge x_2) \vee x_1$ | $(x_1 \vee x_2) \wedge x_1$ |
|-------|-------|-----------------------------|-----------------------------|
| 1     | 1     | 1                           | 1                           |
| 1     | 0     | 1                           | 1                           |
| 0     | 1     | 0                           | 0                           |
| 0     | 0     | 0                           | 0                           |

3.

| $x_1$ | $x_2$ | $x_3$ | $\overline{(x_1 \vee \bar{x}_2)} \vee (\bar{x}_1 \wedge x_3)$ | $\bar{x}_1 \wedge (x_2 \vee x_3)$ |
|-------|-------|-------|---------------------------------------------------------------|-----------------------------------|
| 1     | 1     | 1     | 0                                                             | 0                                 |
| 1     | 1     | 0     | 0                                                             | 0                                 |
| 1     | 0     | 1     | 0                                                             | 0                                 |
| 1     | 0     | 0     | 0                                                             | 0                                 |
| 0     | 1     | 1     | 1                                                             | 1                                 |
| 0     | 1     | 0     | 1                                                             | 1                                 |
| 0     | 0     | 1     | 1                                                             | 1                                 |
| 0     | 0     | 0     | 0                                                             | 0                                 |

5. The Boolean expression for the second circuit can be transformed to the Boolean expression

for the first circuit

$$\begin{aligned} (x_1 \vee x_3) \wedge (x_2 \vee x_3) \wedge (x_2 \vee x_4) \wedge (x_1 \vee x_4) &= (x_3 \vee (x_1 \wedge x_2)) \wedge (x_4 \vee (x_2 \wedge x_1)) \\ &= (x_1 \wedge x_2) \vee (x_3 \wedge x_4) \end{aligned}$$

7.

| $x_1$ | $x_2$ | $x_1 \vee (x_1 \wedge x_2)$ |
|-------|-------|-----------------------------|
| 1     | 1     | 1                           |
| 1     | 0     | 1                           |
| 0     | 1     | 0                           |
| 0     | 0     | 0                           |

8.

| $x_1$ | $x_2$ | $x_1 \wedge \bar{x}_2$ | $\overline{(x_1 \vee x_2)}$ |
|-------|-------|------------------------|-----------------------------|
| 1     | 1     | 0                      | 0                           |
| 1     | 0     | 1                      | 1                           |
| 0     | 1     | 0                      | 0                           |
| 0     | 0     | 0                      | 0                           |

10. The left expression can be transformed into the right expression by successive applications of the distributive and commutative laws:

$$\begin{aligned} (x_1 \vee x_2) \wedge (x_3 \vee x_4) &= ((x_1 \vee x_2) \wedge x_3) \vee ((x_1 \vee x_2) \wedge x_4) \\ &= (x_1 \wedge x_3) \vee (x_2 \wedge x_3) \vee (x_1 \wedge x_4) \vee (x_2 \wedge x_4) \\ &= (x_3 \wedge x_1) \vee (x_3 \wedge x_2) \vee (x_4 \wedge x_1) \vee (x_4 \wedge x_2) \end{aligned}$$

12. False. Take  $x_1 = 1, x_2 = 0$ .  
 13. False. Take  $x_1 = x_2 = x_3 = 1$ .  
 15. False. Take  $x_1 = x_3 = 1$  and  $x_2 = x_4 = 0$ .  
 19. (For Exercise 28, Section 11.1)

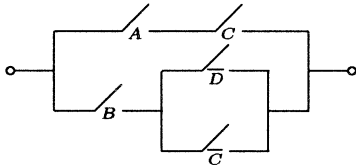

22.

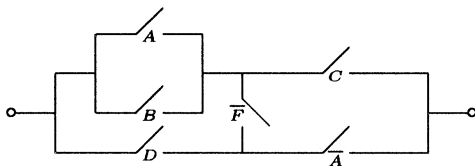

23.

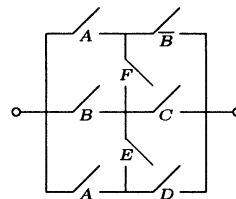

### Section 11.3

3. If  $(S, +, \cdot, ', 1, 8)$  is a Boolean algebra, then  $x + x' = 1$ . In this case, we must have

$$\text{lcm}(x, 8/x) = 8, \text{ for } x = 1, 2, 4, 8.$$

However, for  $x = 4$ ,  $\text{lcm}(4, 8/4) = \text{lcm}(4, 2) = 4$ . Therefore, this system is not a Boolean algebra.

5. In this solution, we denote the 0 (respectively, 1) of a Boolean algebra by  $m$  (respectively,  $M$ ). Every Boolean algebra has at least two elements since  $m$  and  $M$  are distinct. Thus  $n \geq 2$ .

Suppose that  $n > 2$  and that  $S_n$  is a Boolean algebra. Then  $n = n \cdot M = \min\{n, M\}$ . Thus  $M = n$ . For any  $x \in S_n$ , we have  $M = x + x' = \max\{x, x'\}$ . It follows that if  $x \neq M$ , then  $x' = M$ . Therefore, if  $x \neq M$ ,  $x = (x')' = M'$ . This says that  $M'$  is not unique. Contradiction.

If  $n = 2$ , we may take  $m = 1$ ,  $M = 2$ ,  $1' = 2$ , and  $2' = 1$ , and show that  $S_n$  is a Boolean algebra.

6. (a)  $X \cup X = X$ ,  $X \cap X = X$   
 (b)  $X \cup U = U$ ,  $X \cap \emptyset = \emptyset$   
 (c)  $X \cup (X \cap Y) = X$ ,  $X \cap (X \cup Y) = X$   
 (d)  $\overline{\overline{X}} = X$   
 (e)  $\overline{\emptyset} = U$ ,  $\overline{U} = \emptyset$   
 (f)  $\overline{X \cup Y} = \overline{X} \cap \overline{Y}$ ,  $\overline{X \cap Y} = \overline{X} \cup \overline{Y}$
9.  $(x'y) = x + y$
10. If  $xy = xz$  and  $x'y = x'z$ , then  $y = z$ .
12. If  $xy = 1$ , then  $x = 1 = y$ .
13.  $x = 1$  if and only if  $y = (x + y')(x' + y)$  for all  $y$ .
16. (For the dual of Exercise 8)

$$\begin{aligned} xy + x0 &= xy + 0 && \text{by 11.3.6b} \\ &= xy && \text{by 11.3.1d} \end{aligned}$$

$$\begin{aligned} x(x + y)y &= (xx + xy)y && \text{by 11.3.1c} \\ &= (x + xy)y && \text{by 11.3.6a} \\ &= y(x + yx) && \text{by 11.3.1b} \\ &= yx + y(yx) && \text{by 11.3.1c} \\ &= yx + (yy)x && \text{by 11.3.1a} \\ &= yx + yx && \text{by 11.3.6a} \\ &= yx && \text{by 11.3.6a} \\ &= xy && \text{by 11.3.1b} \end{aligned}$$

17. If  $xy = 0$  and  $x + y = 1$ , then  $y = x'$ . The dual of Theorem 11.3.4 is Theorem 11.3.4.
19. (For part c)  $x(x + y) = (x + 0)(x + y) = x + 0y = x + y0 = x + 0 = x$
20. (For part d) We have

$$\begin{aligned} x' + x &= x + x' && \text{by 11.3.1b} \\ &= 1 && \text{by 11.3.1e.} \end{aligned}$$

Dually,  $x'x = 0$ . By Theorem 11.3.4,  $(x')' = x$ .

22. Since 11.3.1a–e hold for all sets, they hold for  $S$ . We need only note that  $\emptyset$  and  $U$  are present and that  $S$  is closed under taking unions, intersections, and complements.
24. First notice that the proof of the absorption laws [Theorem 11.3.6(c)] does *not* use the associative laws. Therefore, the absorption laws follow from the definition of Boolean algebra (Definition 11.3.1) without the associative laws.

We show that

$$a + (b + c) = (a + b) + c$$

by showing that each side of the preceding equation is equal to

$$((a + b) + c)(a + (b + c)).$$

Throughout the proof we make implicit use of the commutative laws, and we use the equations

$$\begin{aligned} a(a + (b + c)) &= a, & b(a + (b + c)) &= b, & c(a + (b + c)) &= c, \\ a((a + b) + c) &= a, & b((a + b) + c) &= b, & c((a + b) + c) &= c. \end{aligned}$$

The first equation follows immediately from the absorption laws. To prove the second equation, we first use the distributive law and then the absorption laws to obtain

$$b(a + (b + c)) = ba + b(b + c) = ba + b = b.$$

The proof of the third equation is similar to the proof of the second equation, and the proofs of the last three equations are similar to the proofs of the first three equations.

We have

$$\begin{aligned} ((a + b) + c)(a + (b + c)) &= ((a + b) + c)a + ((a + b) + c)(b + c) && \text{distributive law} \\ &= a + ((a + b) + c)(b + c) && \text{4th equation} \\ &= a + (((a + b) + c)b + ((a + b) + c)c) && \text{distributive law} \\ &= a + (b + c) && \text{5th and 6th} \\ &&& \text{equations.} \end{aligned}$$

Also

$$\begin{aligned} ((a + b) + c)(a + (b + c)) &= (a + b)(a + (b + c)) + c(a + (b + c)) && \text{distributive law} \\ &= (a + b)(a + (b + c)) + c && \text{3rd equation} \\ &= (a(a + (b + c)) + b(a + (b + c))) + c && \text{distributive law} \\ &= (a + b) + c && \text{1st and 2nd} \\ &&& \text{equations.} \end{aligned}$$

Therefore, the associative law holds for  $+$ . By duality, the associative law holds for  $\cdot$ .

## Section 11.4

In these hints,  $a \wedge b$  is written  $ab$ .

2.  $x\bar{y} \vee \bar{x}y$

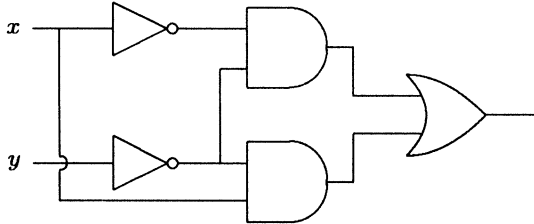

3.  $xyz \vee xy\bar{z} \vee x\bar{y}z \vee \bar{x}\bar{y}z \vee \bar{x}y\bar{z}$

5.  $xyz \vee xy\bar{z} \vee x\bar{y}z \vee \bar{x}y\bar{z} \vee \bar{x}\bar{y}z \vee \bar{x}y\bar{z}$

6.  $xy\bar{z} \vee x\bar{y}z \vee x\bar{y}\bar{z} \vee \bar{x}yz \vee \bar{x}y\bar{z} \vee \bar{x}\bar{y}z$

8.  $x\bar{y}\bar{z} \vee \bar{x}yz \vee \bar{x}y\bar{z} \vee \bar{x}\bar{y}z$

9.  $wxyz \vee wx\bar{y}z \vee w\bar{x}\bar{y}\bar{z} \vee \bar{w}xyz \vee \bar{w}\bar{x}yz$

12.  $x\bar{y} \vee \bar{x}y$

13.  $xyz \vee x\bar{y}z \vee xy\bar{z} \vee x\bar{y}\bar{z} \vee \bar{x}y\bar{z}$

15.  $\bar{x}\bar{y}z \vee \bar{x}\bar{y}\bar{z} \vee \bar{x}y\bar{z}$

16.  $xyz \vee x\bar{y}z \vee xy\bar{z} \vee x\bar{y}\bar{z} \vee \bar{x}\bar{y}z \vee \bar{x}\bar{y}\bar{z}$

18.  $\bar{x}\bar{y}z \vee x\bar{y}\bar{z} \vee \bar{x}\bar{y}\bar{z} \vee \bar{x}yz$

19.  $wxyz \vee w\bar{x}yz \vee wxy\bar{z} \vee wx\bar{y}\bar{z} \vee wx\bar{y}z \vee \bar{w}xyz \vee \bar{w}x\bar{y}z \vee \bar{w}\bar{x}yz \vee \bar{w}\bar{x}\bar{y}z \vee \bar{w}x\bar{y}\bar{z}$

21.  $2^{2^n}$

24. Let  $f: Z_2^n \rightarrow Z_2$ . Let  $A_1, \dots, A_k$  denote the elements  $A_i$  of  $Z_2^n$  for which  $f(A_i) = 0$ . For each  $A_i = (a_1, \dots, a_n)$ , set  $m_i = y_1 \vee \dots \vee y_n$  where

$$y_i = \begin{cases} x_i & \text{if } a_i = 0 \\ \bar{x}_i & \text{if } a_i = 1. \end{cases}$$

Then  $f(x_1, \dots, x_n) = m_1 \wedge m_2 \wedge \dots \wedge m_k$ .

26. (For Exercise 13)  $(x \vee \bar{y} \vee \bar{z})(x \vee y \vee \bar{z})(x \vee y \vee z)$

27. If  $f(x_1, \dots, x_n) = m_1 \vee \dots \vee m_k$ , then  $\overline{f(x_1, \dots, x_n)} = \overline{m_1} \overline{m_2} \dots \overline{m_k}$ . Since each  $m_i = y_1 y_2 \dots y_n$ , where each  $y_j$  is either  $x_j$  or  $\bar{x}_j$ ,  $\overline{m_i} = \bar{y}_1 \vee \bar{y}_2 \vee \dots \vee \bar{y}_n$ . Thus  $f(x_1, \dots, x_n)$  is expressed as the conjunction of maxterms.



29. If  $j > k$ , then some term  $m'_i$  does not occur in the expansion  $m_1 \vee \dots \vee m_k$ . Choose  $x_i \in Z_2$  so that  $m'_i = 1$ . Show that  $m_i = 0$  for  $i = 1, \dots, n$ . Conclude that  $j \leq k$ . Similarly,  $j \geq k$ . Therefore,  $j = k$ .

Give a similar argument to show that each  $m_i$  is equal to some  $m'_i$ .

### Section 11.5

3. A combinatorial circuit consisting only of OR gates would output 0 when all inputs are 0.
4. A combinatorial circuit consisting only of NOT gates would have as many outputs as inputs.
7.  $xy = (x \uparrow y) \uparrow (x \uparrow y)$
8. False. Take  $x = 1$  and  $y = z = 0$ .

10.  $y_1 = \overline{x_1}$ ,  $y_2 = \overline{x_1} \vee \overline{x_2}$ ,  $y_3 = \overline{x_2}x_3(\overline{x_1} \vee \overline{x_2})x_1$

11. 
$$y_1 = x_1 \wedge x_2$$

$$y_2 = \overline{(x_1 \wedge x_2) \vee \overline{x_3}}$$

$$y_3 = ((x_1 \wedge x_2) \vee \overline{x_3}) \wedge x_1 \wedge x_2 \wedge \overline{x_3} \wedge x_4$$

$$y_4 = \overline{x_3} \wedge x_4$$

16. See the solution to Exercise 15.

18.  $x \downarrow y = ((x \uparrow x) \uparrow (y \uparrow y)) \uparrow ((x \uparrow x) \uparrow (y \uparrow y))$

19.

| $x_1$ | $x_2$ | $x_1 \downarrow x_2$ |
|-------|-------|----------------------|
| 1     | 1     | 0                    |
| 1     | 0     | 0                    |
| 0     | 1     | 0                    |
| 0     | 0     | 1                    |

21. (For Exercise 3) Write  $xy \vee x\overline{z} \vee \overline{x}y = x(y \vee \overline{z}) \vee \overline{x}y = \overline{\overline{x \vee y \vee \overline{z}}} \vee \overline{x \vee y}$ , which gives

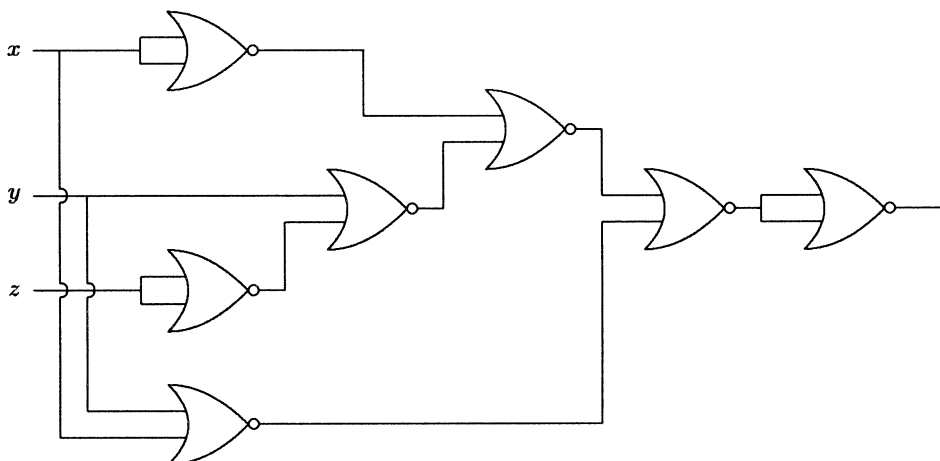

24. See the solution to Exercise 23.  
 26. The standard multiplication algorithm gives

$$\begin{array}{r}
 \phantom{x_2} x_1 \\
 \phantom{x_2} y_2 \phantom{y_1} \\
 \hline
 \phantom{x_2} x_2 y_1 \phantom{x_1 y_1} \\
 \phantom{x_2} x_1 y_2 \\
 \hline
 z_4 \phantom{z_3} z_3 \phantom{z_2} z_2 \phantom{z_1} \\
 \hline
 \phantom{z_4} z_3 \phantom{z_2} z_2 \phantom{z_1} \\
 \hline
 z_4 \phantom{z_3} z_3 \phantom{z_2} z_2 \phantom{z_1}
 \end{array}$$

This computation can be performed by the following circuit

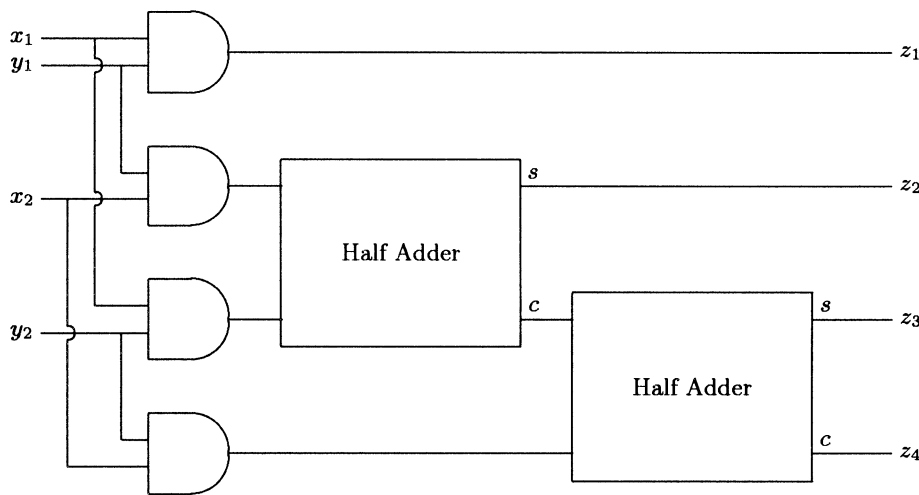

29. 00101      30. 100101010

32. The simplest approach is to simply rewrite each of the properties in 11.3.1 using the star operator. Notice that in some cases the dual properties can be given in one star expression. For example,

$$x * ((y * z) * (y * z)) = ((x * y) * (x * y)) * z$$

is sufficient to prove both associative laws.

J. G. P. Nicod in “A reduction in the number of primitive propositions of logic,” *Proceedings of the Cambridge Philosophical Society*, 19 (1916), 32–40, has shown that the following *single* axiom is sufficient to establish all of the properties of a Boolean algebra

$$(a * (b * c)) * ((d * (d * d)) * ((e * b) * ((a * e) * (a * e)))) = 1.$$

35. We use induction on the number  $n$  of occurrences of  $\leftrightarrow$  in  $B(x, y)$  to prove parts a and b simultaneously. For the Basis Step, suppose that there are 0 occurrences of  $\leftrightarrow$  in  $B(x, y)$ . If  $B(x, y)$  contains an even number of  $x$ 's, then either  $B(x, y) = 0$ ,  $B(x, y) = 1$ , or  $B(x, y) = y$ . In all cases,  $B(\bar{x}, y) = B(x, y)$  for all  $x$  and  $y$ . If  $B(x, y)$  contains an odd number of  $x$ 's, then  $B(x, y) = x$ . In this case,  $B(\bar{x}, y) = \overline{B(x, y)}$  for all  $x$  and  $y$ .

Now suppose that there are  $n$  occurrences of  $\leftrightarrow$  in  $B(x, y)$ . Then  $B(x, y) = (B_1(x, y) \leftrightarrow B_2(x, y))$ , where each of  $B_1(x, y)$  and  $B_2(x, y)$  contains fewer than  $n$  occurrences of  $\leftrightarrow$ .

Suppose first that  $B(x, y)$  contains an even number of  $x$ 's. If  $B_1(x, y)$  contains an even number of  $x$ 's, so does  $B_2(x, y)$ . By the inductive assumption,

$$B(\bar{x}, y) = (B_1(\bar{x}, y) \leftrightarrow B_2(\bar{x}, y)) = (B_1(x, y) \leftrightarrow B_2(x, y)) = B(x, y).$$

If  $B_1(x, y)$  contains an odd number of  $x$ 's, so does  $B_2(x, y)$ . By the inductive assumption,

$$B(\bar{x}, y) = (B_1(\bar{x}, y) \leftrightarrow B_2(\bar{x}, y)) = (\overline{B_1(x, y)} \leftrightarrow \overline{B_2(x, y)}) = (B_1(x, y) \leftrightarrow B_2(x, y)) = B(x, y).$$

Now suppose that  $B(x, y)$  contains an odd number of  $x$ 's. Then one of  $B_1(x, y)$  or  $B_2(x, y)$  contains an odd number of  $x$ 's. We may assume that  $B_1(x, y)$  contains an odd number of  $x$ 's. Then  $B_2(x, y)$  contains an even number of  $x$ 's. By the inductive assumption,

$$B(\bar{x}, y) = (B_1(\bar{x}, y) \leftrightarrow B_2(\bar{x}, y)) = (\overline{B_1(x, y)} \leftrightarrow B_2(x, y)) = \overline{B(x, y)}.$$

The Inductive Step is complete, and parts a and b are proved.

Using parts a and b, we may show that there is no Boolean expression using only  $\leftrightarrow$  that computes the function

| $x$ | $y$ | $f(x, y)$ |
|-----|-----|-----------|
| 1   | 1   | 0         |
| 1   | 0   | 1         |
| 0   | 1   | 0         |
| 0   | 0   | 0         |

For suppose that there is a Boolean function  $B(x, y)$  using only the  $\leftrightarrow$  operator with  $f(x, y) = B(x, y)$ . If  $B(x, y)$  contains an even number of  $x$ 's, part a tells us that we must have  $B(0, 0) = B(1, 0)$ , which is not the case. If  $B(x, y)$  contains an odd number of  $x$ 's, part b tells us that we must have  $B(0, 1) = \overline{B(1, 1)}$ , which is not the case. Therefore  $\{\leftrightarrow\}$  is not functionally complete.



## Chapter 12

# Solutions to Selected Exercises

### Section 12.1

2.

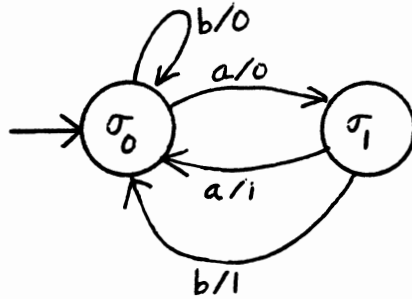

3.

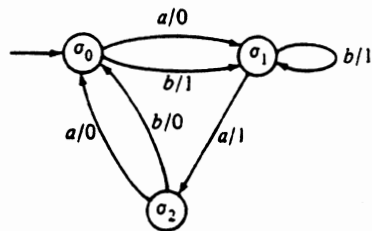

5.

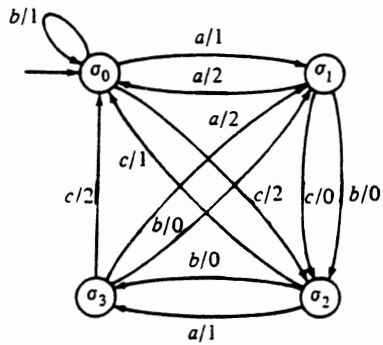

7.  $\mathcal{I} = \{a, b\}$ ;  $\mathcal{O} = \{0, 1\}$ ,  $\mathcal{S} = \{A, B, C\}$ ; initial state =  $A$

| $\mathcal{S} \setminus \mathcal{I}$ | $a$ | $b$ | $a$ | $b$ |
|-------------------------------------|-----|-----|-----|-----|
| $A$                                 | $A$ | $B$ | 0   | 1   |
| $B$                                 | $A$ | $C$ | 0   | 1   |
| $C$                                 | $C$ | $A$ | 1   | 0   |

8.  $\mathcal{I} = \{a, b\}$ ;  $\mathcal{O} = \{0, 1, 2\}$ ;  $\mathcal{S} = \{\sigma_0, \sigma_1, \sigma_2\}$ ; initial state =  $\sigma_0$

| $\mathcal{S} \setminus \mathcal{I}$ | $a$        | $b$        | $a$ | $b$ |
|-------------------------------------|------------|------------|-----|-----|
| $\sigma_0$                          | $\sigma_1$ | $\sigma_0$ | 0   | 2   |
| $\sigma_1$                          | $\sigma_1$ | $\sigma_0$ | 2   | 1   |
| $\sigma_2$                          | $\sigma_1$ | $\sigma_0$ | 0   | 1   |

10.  $\mathcal{I} = \{a, b, c\}$ ;  $\mathcal{O} = \{0, 1, 2\}$ ;  $\mathcal{S} = \{A, B, C, D\}$ ; initial state =  $B$

| $\mathcal{S} \setminus \mathcal{I}$ | $a$ | $b$ | $c$ | $a$ | $b$ | $c$ |
|-------------------------------------|-----|-----|-----|-----|-----|-----|
| $A$                                 | $B$ | $A$ | $C$ | 1   | 0   | 2   |
| $B$                                 | $A$ | $D$ | $D$ | 2   | 0   | 0   |
| $C$                                 | $A$ | $C$ | $D$ | 0   | 1   | 2   |
| $D$                                 | $D$ | $C$ | $A$ | 2   | 2   | 0   |

12. 0100

13. 0101100

15. 121121

16. 011

18. 20210

19. 010000000001

22.

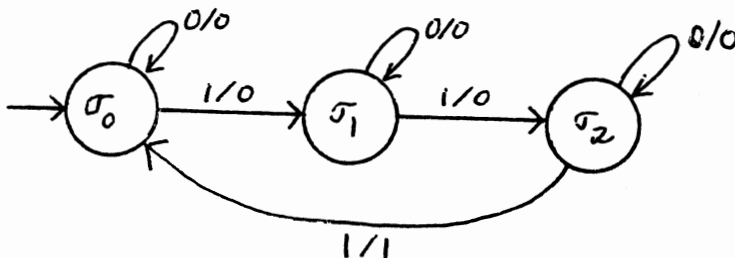

23.

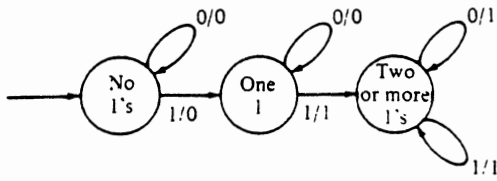

25.

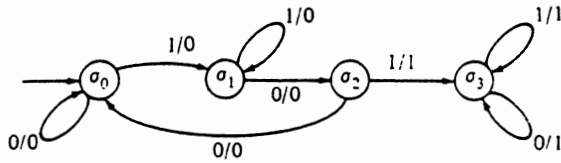

26.

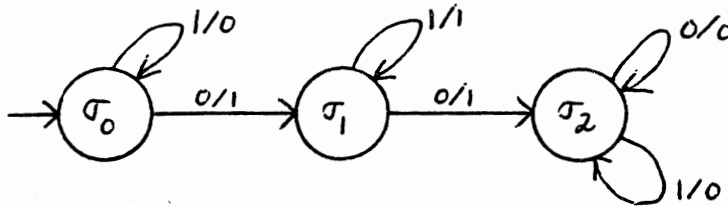

29. Suppose that such a finite-state machine  $M$  exists and has  $m$  states. Let  $X$  and  $Y$  each be 1 followed by  $m + 2$  0's. Then the sequence

$$\underbrace{00, 00, \dots, 00}_{m+2}, \underbrace{00, 00, \dots, 00}_{m+3}$$

is input to  $M$ . The product of  $X$  and  $Y$  is 1 followed by  $2m + 4$  0's. The output is

$$\underbrace{0, 0, \dots, 0}_{2m+4}, 1, 0.$$

After 11 is input, a sequence of  $m + 1$  00's is input and the output is 0 each time. Since there are only  $m$  states, we must return to a state that we previously visited. That is, the path in the transition diagram contains a cycle. Since the input is constant (00), we must remain on this cycle. Therefore, we continue outputting 0's and we never output 1.

Section 12.2

2. All incoming edges to  $\sigma_0$  output 0, all incoming edges to  $\sigma_1$  output 1, and all incoming edges to  $\sigma_2$  output 0; hence, the finite-state machine is a finite-state automaton.

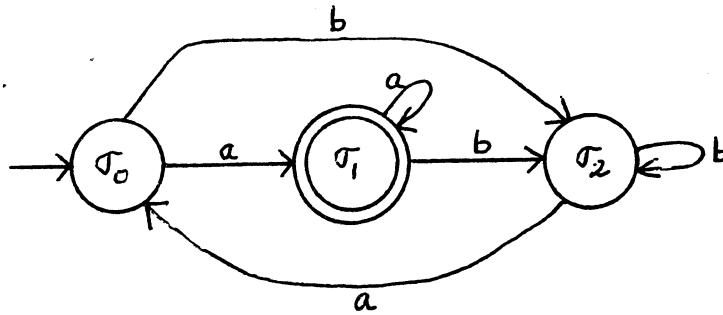

3.

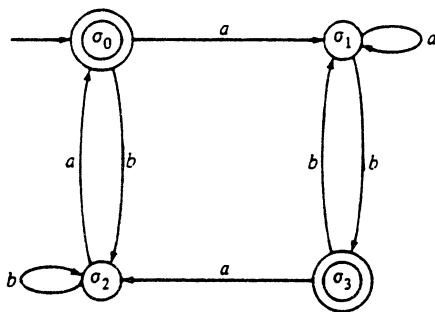

5.

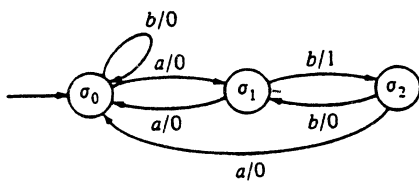

6.

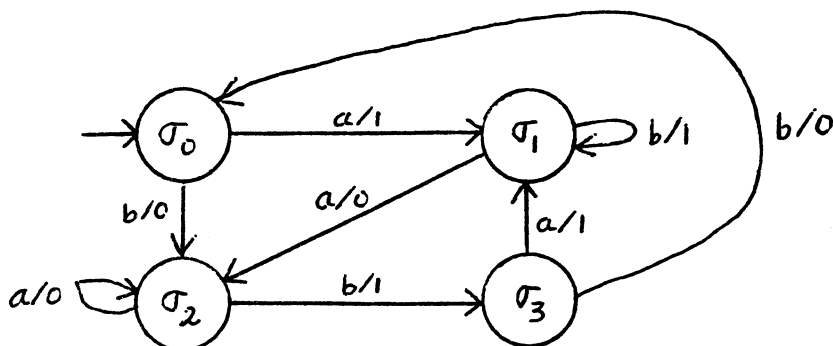



8.

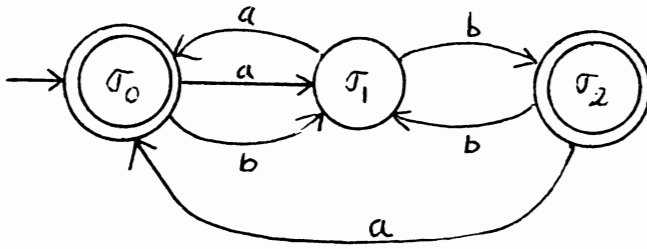

9.

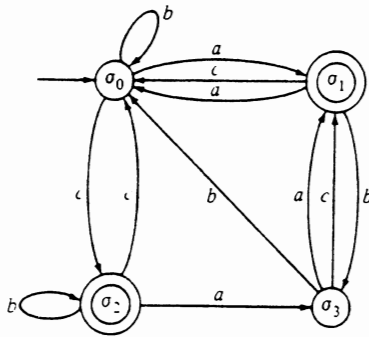

11. 1,7,9

12. The following must hold for all states  $\sigma$ : All entries in the output table corresponding to occurrences of  $\sigma$  in the next-state table must be identical.

14. Not accepted

15. Accepted

17. Accepted

19. If a string  $\alpha$ , which ends  $bb$  is input, no matter which state we are in prior to  $bb$ , we will end at state  $\sigma_2$ , as can be seen by checking the three possibilities. Since  $\sigma_2$  is accepting,  $\alpha$  is accepted.

Suppose that  $\alpha$  is accepted by Figure 12.2.5. We end in state  $\sigma_2$ . Thus the last character in  $\alpha$  is  $b$ . There is at least one character before  $b$ . If the last two characters are  $ab$  and we are in state  $\alpha$  just before the  $a$ , by checking the three possibilities for  $\sigma$ , we can show that we will not end in  $\sigma_2$ . Therefore, the last two characters are  $bb$ .

22.

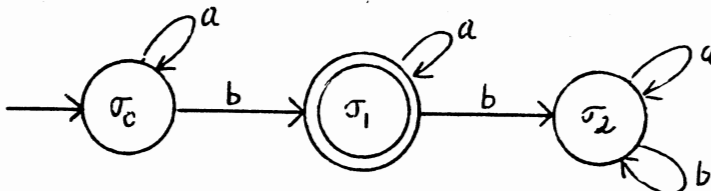

23.

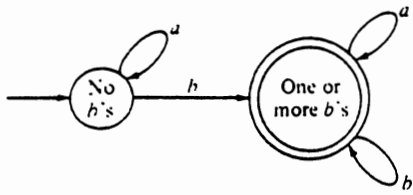

25.

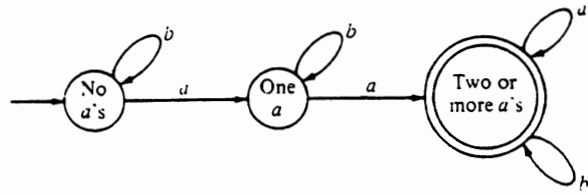

26.

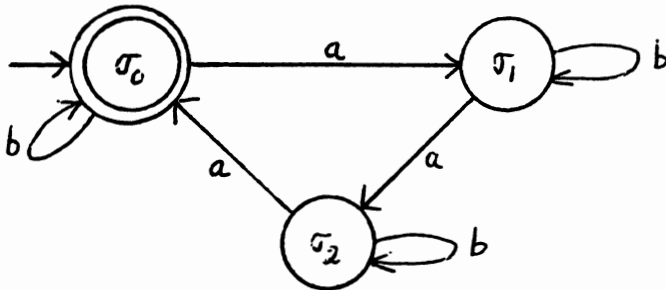

28.

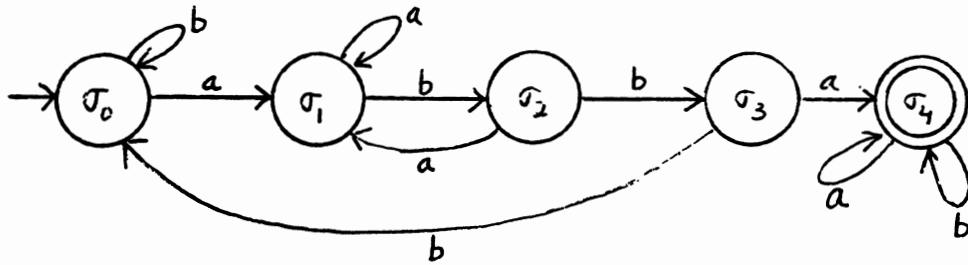

29.

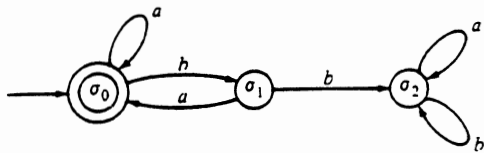

31.

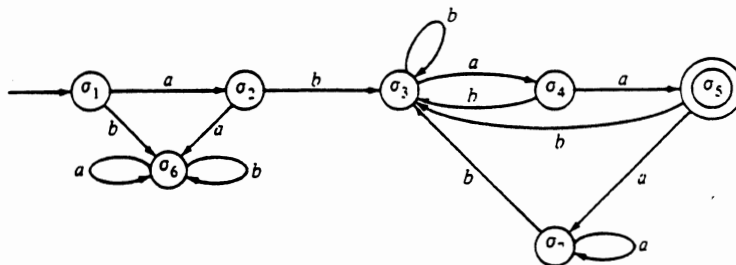

33. If a string consisting only of  $b$ 's is input to either finite-state automaton, it is accepted. If a string contains an  $a$ , in either finite-state automaton we move to a nonaccepting state. In neither finite-state automaton is there an edge from a nonaccepting state to an accepting state. Thus once an  $a$  is encountered, both finite-state automata reject the string. Therefore, the set of strings accepted by each finite-state automaton is the same—namely, the set of strings over  $\{a, b\}$  that do not contain an  $a$ .
34. If  $L$  is empty, the finite-state automaton



accepts  $L$ .

If  $L$  consists of the null string, the finite-state automaton

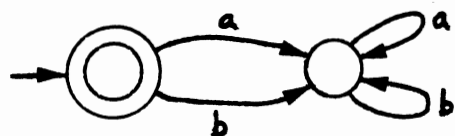

accepts  $L$ .

If  $L$  consists of one nonnull string  $x_1x_2 \dots x_k$ , the finite-state automaton

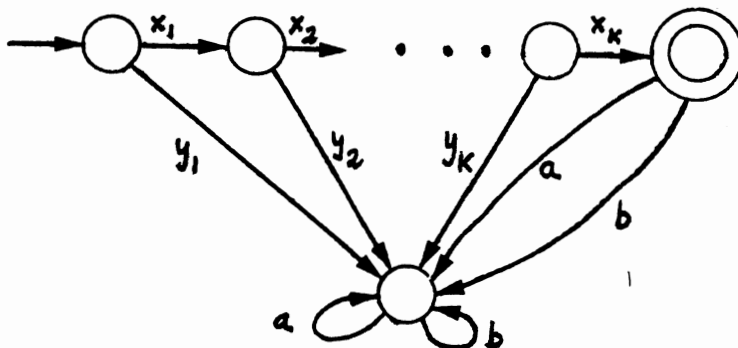

where

$$y_i = \begin{cases} a & \text{if } x_i = b \\ b & \text{if } x_i = a \end{cases}$$

accepts  $L$ .

If  $L = \{s_1, \dots, s_n\}$ , we have shown how to construct finite-state automata that accept  $L_i = \{s_i\}$ ,  $i = 1, \dots, n$ . Exercise 37 shows how to construct a finite-state automaton that accepts  $L = L_1 \cup L_2 \cup \dots \cup L_n$ .

36. The argument is similar to that given in Exercise 37.
37. Suppose that  $x_1 \dots x_n \in L_1$ . Then there exist states  $s_{10}, \dots, s_{1n}$  satisfying

$$\begin{aligned} s_{10} &= \sigma_1; \\ f_1(s_{1,i-1}, x_i) &= s_{1i} \text{ for } i = 1, \dots, n; \\ s_{1n} &\in \mathcal{A}_1. \end{aligned}$$

Define

$$\begin{aligned} s_{20} &= \sigma_2; \\ s_{2i} &= f_2(s_{2,i-1}, x_i) \quad \text{for } i = 1, \dots, n; \\ s_i &= (s_{1i}, s_{2i}) \quad \text{for } i = 0, \dots, n. \end{aligned}$$

Now

$$\begin{aligned} s_0 &= \sigma; \\ f(s_{i-1}, x_i) &= (s_{1i}, s_{2i}) \quad \text{for } i = 1, \dots, n; \\ s_n &= (s_{1n}, s_{2n}) \in \mathcal{A}. \end{aligned}$$

Thus  $L_1 \subseteq \text{Ac}(A)$ . Similarly,  $L_2 \subseteq \text{Ac}(A)$ . Therefore,

$$L_1 \cup L_2 \subseteq \text{Ac}(A).$$

A similar kind of argument may be used to show that  $\text{Ac}(A) \subseteq L_1 \cup L_2$ .

39. Use Exercises 36 and 37.

## Section 12.3

2. None                    3. Context-sensitive                    5. Regular, context-free, context-sensitive

6. None

8.  $\sigma \Rightarrow AB \Rightarrow aAB \Rightarrow aABb \Rightarrow aBAb \Rightarrow abAb \Rightarrow abab$

9.  $\sigma \Rightarrow AAB \Rightarrow AaaB \Rightarrow ABaaB \Rightarrow ABAab \Rightarrow ABBAab \Rightarrow aaBBaab \Rightarrow aabBaab \Rightarrow aabbaab$

11.  $\langle S \rangle \Rightarrow a \langle A \rangle \Rightarrow ab \langle B \rangle \Rightarrow aba \langle S \rangle \Rightarrow abaa \langle A \rangle \Rightarrow abaab \langle B \rangle$   
 $\Rightarrow abaabb \langle A \rangle \Rightarrow abaabba \langle S \rangle \Rightarrow abaabbab \langle S \rangle \Rightarrow abaabbabb \langle S \rangle \Rightarrow abaabbabba$

13. The productions  $\sigma \rightarrow b\sigma$ ,  $A \rightarrow bA$ , and  $\sigma \rightarrow b$  generate any number of  $b$ 's. If these are omitted, the only derivations possible are

$$\sigma \Rightarrow aA \Rightarrow aa\sigma \Rightarrow \dots \Rightarrow (aa)^n \sigma \Rightarrow (aa)^n aA \Rightarrow (aa)^{n+1}.$$

14. An accepted string is of the form  $x_1 x_2 \dots x_n$ , where  $x_1 = b^*a$  and  $x_2, \dots, x_n$  are any of  $ab^*a$ ,  $(bb)^*$ , or  $bab^*a$ .

16.  $S \rightarrow aS$ ,  $S \rightarrow bS$ ,  $S \rightarrow bA$ ,  $A \rightarrow a$

17.  $S \rightarrow aS$ ,  $S \rightarrow bA$ ,  $A \rightarrow bA$ ,  $A \rightarrow aB$ ,  $B \rightarrow aB$ ,  $B \rightarrow bB$ ,  $B \rightarrow a$ ,  $B \rightarrow b$ ,  $A \rightarrow a$

19.                     $\langle \text{digit} \rangle ::= 0|1|2|3|4|5|6|7|8|9$   
                        $\langle \text{nonzero digit} \rangle ::= 1|2|3|4|5|6|7|8|9$   
                        $\langle \text{integer} \rangle ::= \langle \text{signed integer} \rangle | \langle \text{unsigned integer} \rangle$   
                        $\langle \text{signed integer} \rangle ::= +\langle \text{unsigned integer} \rangle | -\langle \text{unsigned integer} \rangle$   
                        $\langle \text{unsigned integer} \rangle ::= \langle \text{digit} \rangle | \langle \text{nonzero digit} \rangle \langle \text{digit string} \rangle$   
                        $\langle \text{digit string} \rangle ::= \langle \text{digit} \rangle | \langle \text{digit} \rangle \langle \text{digit string} \rangle$

20.  $\langle \text{float number} \rangle ::= . \langle \text{integer} \rangle \mid \langle \text{integer} \rangle . \mid \langle \text{integer} \rangle . \langle \text{integer} \rangle$

22.  $\langle \text{BOOL} \rangle ::= 0 \mid 1 \mid X_1 \mid X_2 \mid \dots \mid X_n \mid (\langle \text{BOOL} \rangle) \mid \overline{\langle \text{BOOL} \rangle} \mid \langle \text{BOOL} \rangle \vee \langle \text{BOOL} \rangle \mid \langle \text{BOOL} \rangle \wedge \langle \text{BOOL} \rangle$

23.  $S \rightarrow aS, S \rightarrow bS, S \rightarrow \lambda$

26. This grammar does generate  $L$ . Every string that the grammar generates is in  $L$ , since anytime an  $a$  is generated, a  $b$  is generated and vice versa.

To show that every string  $s \in L$  is generated, we argue by induction on the length of  $s$ . If the length of  $s$  is 0,  $s$  is generated. Suppose that  $s \in L$  and that  $s$  starts with  $a$ . (The argument is similar if  $s$  starts with  $b$ .)

Suppose first that  $s$  ends with  $b$ . Then  $s = atb$ , where  $t$  is a string shorter than  $s$  and  $t \in L$ . By the inductive assumption,  $S \Rightarrow t$ . But now

$$S \Rightarrow aSb \Rightarrow atb = s$$

is a derivation of  $s$ . Therefore  $s$  is in the language generated by the grammar.

Suppose that  $s$  ends with  $a$ . Then  $s = tu$ , where  $t$  and  $u$  are each shorter strings than  $s$  and  $t, u \in L$ . By the inductive assumption,  $S \Rightarrow t$  and  $S \Rightarrow u$ . But now

$$S \Rightarrow SS \Rightarrow tu = s$$

is a derivation of  $s$ . Again  $s$  is in the language generated by the grammar.

27. This grammar does not generate  $L$ ;  $aabb$  is a counterexample.

29. This grammar does not generate  $L$ ;  $aabbbbaa$  is a counterexample.

30. This grammar does not generate  $L$ ;  $abba$  is a counterexample.

34. The language is generated by the context-free language

$$S \rightarrow AC, C \rightarrow cC, C \rightarrow c, A \rightarrow aAb, A \rightarrow ab$$

36.  $S \rightarrow -AD+SDS+DA- \mid s$   
 $A \rightarrow +SD-ADA-DS+ \mid a$   
 $D \rightarrow D \mid d$   
 $+ \rightarrow +$   
 $- \rightarrow -$

$a$  and  $s$  are ignored when drawing the figure.

### Section 12.4

2.

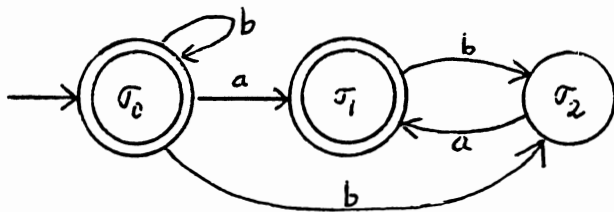

3.

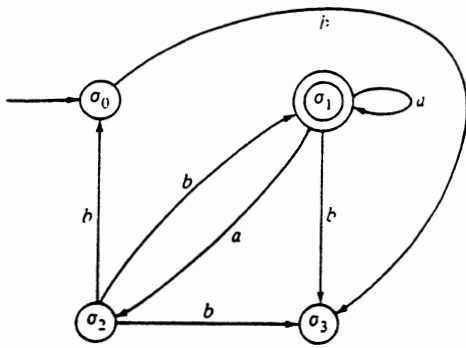

5.

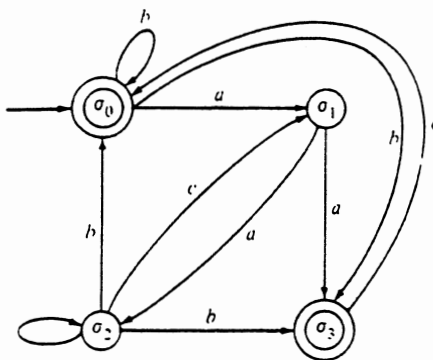
7.  $\mathcal{I} = \{a, b\}$ ,  $\mathcal{S} = \{A, B, C\}$ ,  $\mathcal{A} = \{A, C\}$ , initial state =  $A$ 

| $S \setminus \mathcal{I}$ | $a$         | $b$         |
|---------------------------|-------------|-------------|
| $A$                       | $\{A, C\}$  | $\{B\}$     |
| $B$                       | $\{C\}$     | $\{B, C\}$  |
| $C$                       | $\emptyset$ | $\emptyset$ |

8.  $\mathcal{I} = \{a, b\}$ ,  $\mathcal{S} = \{\sigma_0, \sigma_1, \sigma_2, \sigma_3\}$ ,  $\mathcal{A} = \{\sigma_3\}$ , initial state =  $\sigma_0$ 

| $S \setminus \mathcal{I}$ | $a$            | $b$                      |
|---------------------------|----------------|--------------------------|
| $\sigma_0$                | $\{\sigma_0\}$ | $\{\sigma_0, \sigma_1\}$ |
| $\sigma_1$                | $\{\sigma_2\}$ | $\emptyset$              |
| $\sigma_2$                | $\emptyset$    | $\{\sigma_3\}$           |
| $\sigma_3$                | $\emptyset$    | $\emptyset$              |

10.  $\mathcal{I} = \{a, b\}$ ,  $\mathcal{S} = \{\sigma_0, \sigma_1, \sigma_2, \sigma_3\}$ ,  $\mathcal{A} = \{\sigma_3\}$ , initial state =  $\sigma_0$ 

| $S \setminus \mathcal{I}$ | $a$            | $b$            |
|---------------------------|----------------|----------------|
| $\sigma_0$                | $\emptyset$    | $\{\sigma_1\}$ |
| $\sigma_1$                | $\{\sigma_2\}$ | $\emptyset$    |
| $\sigma_2$                | $\emptyset$    | $\{\sigma_3\}$ |
| $\sigma_3$                | $\{\sigma_3\}$ | $\{\sigma_3\}$ |

12. (For Exercise 1, Section 12.3)

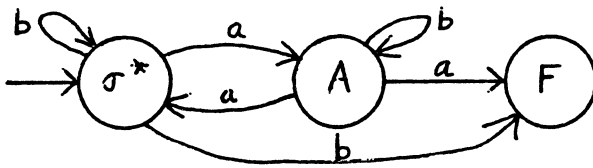

13. Yes. The path  $(\sigma, \sigma, \sigma, C, C, C, F)$  represents  $bbabbb$  and ends at an accepting state.
15. The string  $\alpha$  is of the form  $b^n ab^m$ , where  $n \geq 0$  and  $m \geq 1$ . A path representing this string terminating at  $F$  is  $(\sigma^{n+1} C^m F)$ . Any path starting at  $\sigma$  terminating at  $F$  is of the form  $(\sigma^{n+1} C^m F)$  and thus represents  $b^n ab^m$ , where  $n \geq 0$  and  $m \geq 1$ .
16. No. For the first three characters,  $aaa$ , either we follow the path  $(\sigma, \sigma, \sigma, C)$  or the path  $(\sigma, \sigma, \sigma, \sigma)$ . From  $C$ , on the first path, the next two moves are determined and we remain at  $C$ . But now we cannot move on the final  $a$ . From the last  $\sigma$  on the second path, the next move is determined and we move to  $D$ . But now we cannot move on the next  $b$ .
18.  $\{a^n b^m \mid n \geq 1, m \geq 0\} \cup \{ba^n b^m \mid n \geq 1, m \geq 0\}$
19. To reach  $\sigma_3$  on a path from  $\sigma_0$ , we must have ended  $bab$ . Any string that ends  $bab$  is accepted, since we can remain at  $\sigma_0$  until we encounter the final  $bab$ , at which time we move successively to  $\sigma_1$ ,  $\sigma_2$ , and  $\sigma_3$ .

22.

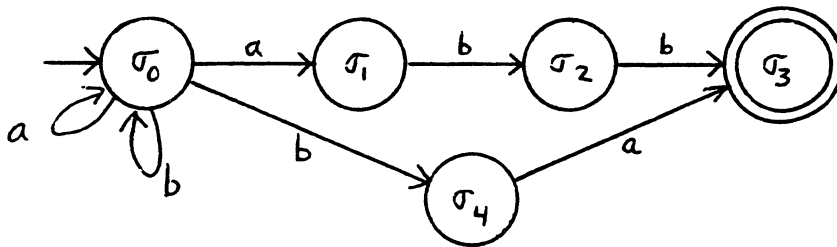

23.

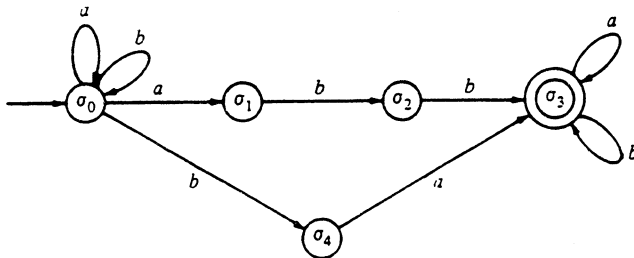

25.

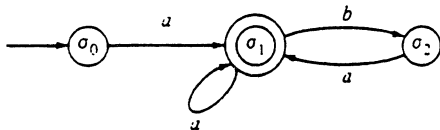

26.

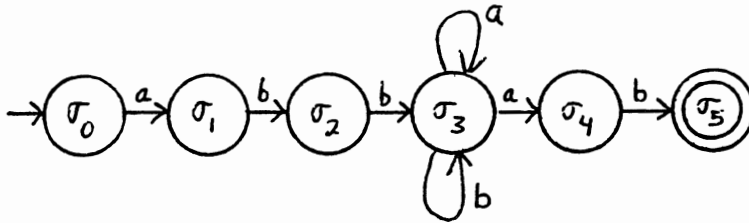

28.

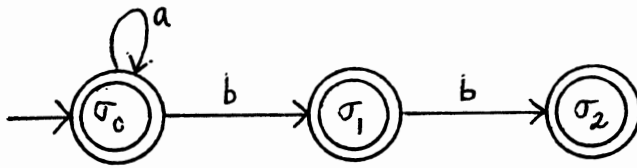

29. Use Exercise 36, Section 12.2.

## Section 12.5

3.

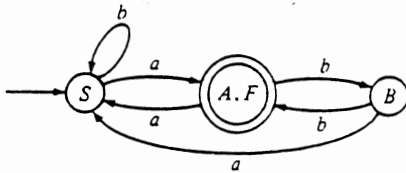

4.

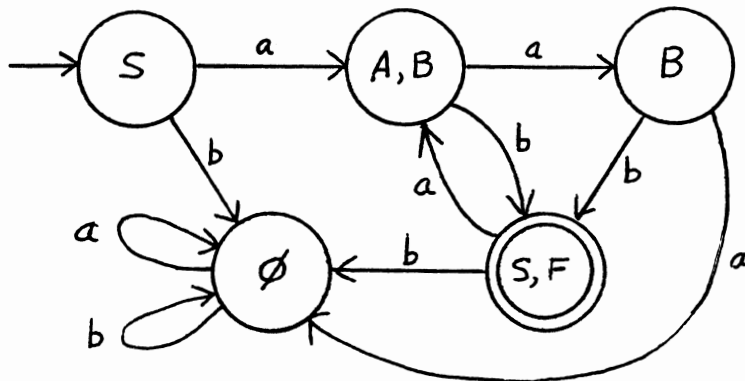



6.

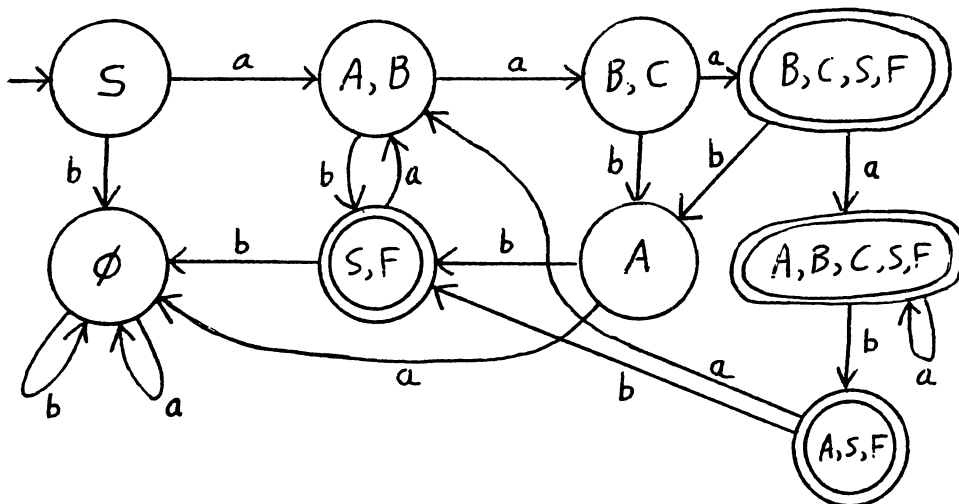

8.

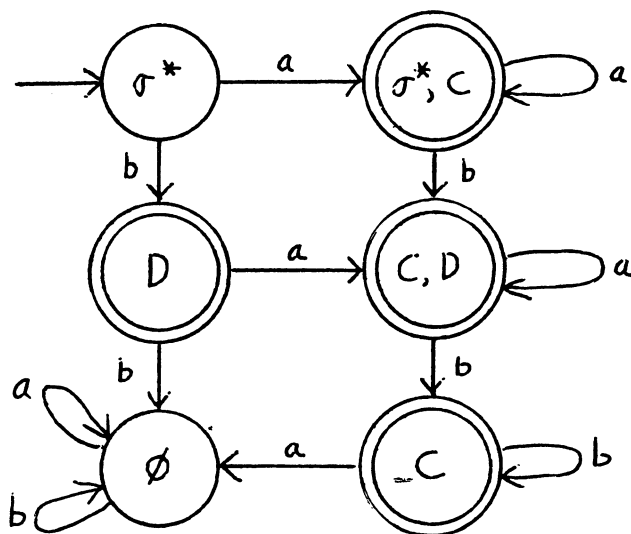

9. Exercise 19, Section 12.2, shows that Figure 12.5.4 accepts precisely the strings over  $\{a, b\}$  that end  $bb$ . We may now use Example 12.5.7 to conclude that Figure 12.5.5 accepts precisely the strings over  $\{a, b\}$  that start  $bb$ .

12.

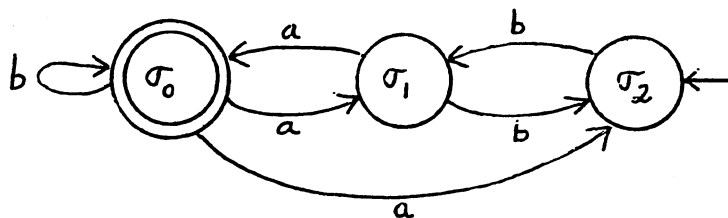

13.

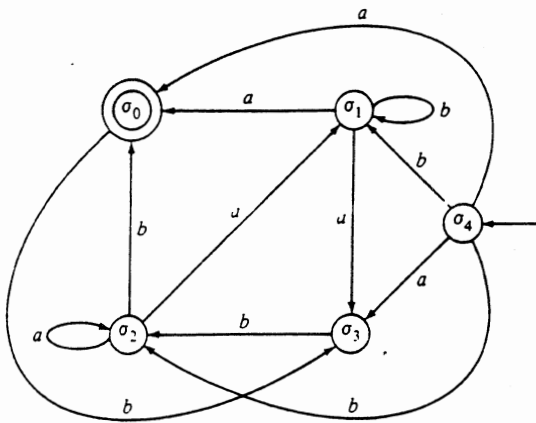

15. To find the nondeterministic finite-state automaton that accepts  $Ac(A)^+$ , allow an edge in  $A$  that terminates on an accepting state to optionally return to the starting state:

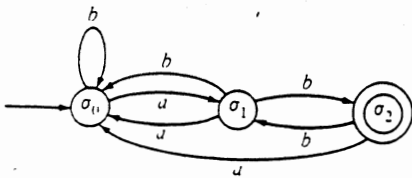

16.

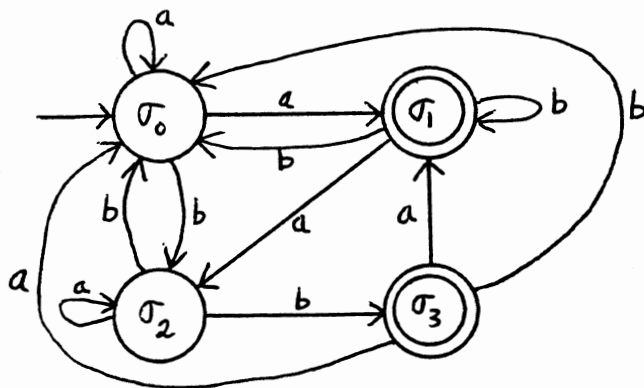

18.

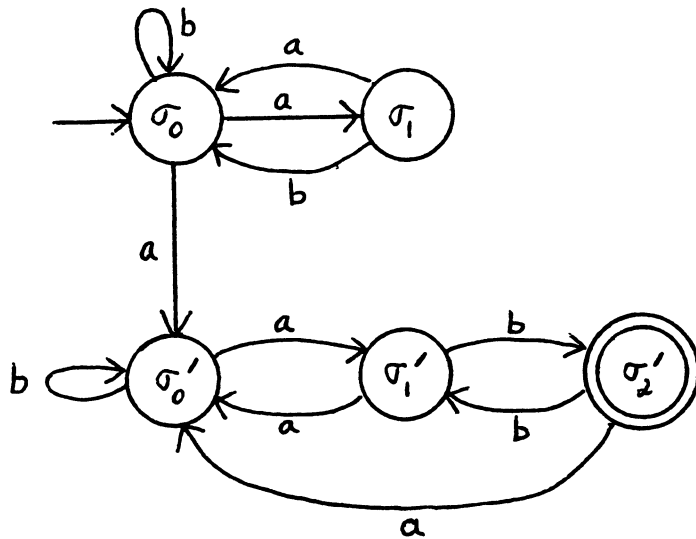

19. Allow an edge in  $A_1$  that terminates on an accepting state in  $A_1$  to terminate optionally on the starting state in  $A_2$ . The accepting states of the nondeterministic finite-state automaton are the accepting states of  $A_2$ :

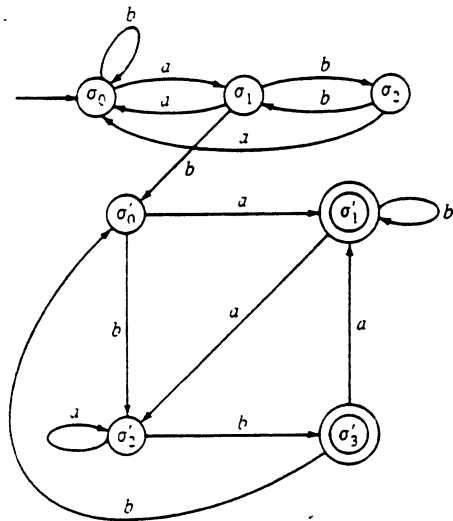

21. See the hint for Exercise 19.

23. Allow any terminating production, alternatively, to return to the start:

$$\begin{aligned}
 \langle S \rangle &::= b \langle S \rangle \mid a \langle A \rangle \mid a \langle S \rangle \mid a \\
 \langle A \rangle &::= a \langle S \rangle \mid b \langle B \rangle \\
 \langle B \rangle &::= b \langle A \rangle \mid a \langle S \rangle \mid b \langle S \rangle \mid b
 \end{aligned}$$

24. Replace any terminating production of  $L_1$  with the starting symbol of  $L_2$ :

$$\begin{aligned}\langle S \rangle &::= b \langle S \rangle \mid a \langle A \rangle \mid a \langle \sigma \rangle \\ \langle A \rangle &::= a \langle S \rangle \mid b \langle B \rangle \\ \langle B \rangle &::= b \langle A \rangle \mid a \langle S \rangle \mid b \langle \sigma \rangle \\ \langle \sigma \rangle &::= b \langle \sigma \rangle \mid a \langle C \rangle \\ \langle C \rangle &::= b \langle C \rangle \mid b\end{aligned}$$

26. Use Exercises 35–37, Section 12.2, and the methods of Exercises 23 and 24.

27. Consider

$$\begin{aligned}L_1 &= \{a^n b^n c^k \mid n, k \in \{1, 2, \dots\}\} \\ L_2 &= \{a^k b^n c^n \mid n, k \in \{1, 2, \dots\}\}.\end{aligned}$$

# Chapter 13

## Solutions to Selected Exercises

### Section 13.1

2. Some pair is equal.

3.  $\{(1, 1), (1, 1), (1, 1), (1, 1)\}$

5. Modify Algorithm 13.1.2 as follows.

Add the parameters  $x_1, y_1, x_2, y_2$  in which the  $x$ - and  $y$ -coordinates of a closest pair will be returned.

Add the lines

$x_1 = x$ -coordinate of first member of closest pair  
 $y_1 = y$ -coordinate of first member of closest pair  
 $x_2 = x$ -coordinate of second member of closest pair  
 $y_2 = y$ -coordinate of second member of closest pair

after the line

directly find the distance  $\delta$  between a closest pair

Replace the lines

$\delta_L = \text{rec\_cl\_pair}(p, i, k)$   
 $\delta_R = \text{rec\_cl\_pair}(p, k + 1, j)$

by

$\delta_L = \text{rec\_cl\_pair}(p, i, k, x_{1L}, y_{1L}, x_{2L}, y_{2L})$   
 $\delta_R = \text{rec\_cl\_pair}(p, k + 1, j, x_{1R}, y_{1R}, x_{2R}, y_{2R})$   
if  $(\delta_L < \delta_R)$  {  
     $x_1 = x_{1L}$   
     $y_1 = y_{1L}$   
     $x_2 = x_{2L}$   
     $y_2 = y_{2L}$   
     $\delta = \delta_L$   
}

```

else {
 $x_1 = x_{1R}$
 $y_1 = y_{1R}$
 $x_2 = x_{2R}$
 $y_2 = y_{2R}$
 $\delta = \delta_R$
}

```

Replace the line

$$\delta = \min\{\delta, \text{dist}(v_k, v_s)\}$$

by

```

if ($\text{dist}(v_k, v_s) < \delta$) {
 $\delta = \text{dist}(v_k, v_s)$
 $x_1 = v_k.x$
 $y_1 = v_k.y$
 $x_2 = v_s.x$
 $y_2 = v_s.y$
}

```

6. Input:  $x_1, \dots, x_n, n$   
 Output: the distance between a closest pair

```

one_dim_cl_pair(x, n) {
 sort x_1, \dots, x_n
 $dist = \infty$
 for $i = 2$ to n
 $dist = \min\{dist, |x_i - x_{i-1}|\}$
 return $dist$
}

```

8.

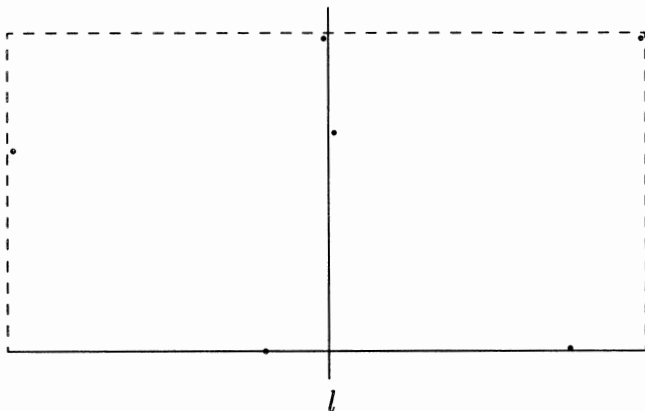

9. No. There could be points  $q_1$  and  $q_2$  with  $q_2$  closer to  $p$  than  $q_1$ , yet the  $y$ -coordinate of  $q_2$  exceeds the  $y$ -coordinate of  $q_1$ .

```

11. find_all(p, n) {
 $\delta = \text{closest_pair}(p, n)$ // original function
 if ($\delta > 0$) {
 sort p_1, \dots, p_n by x-coordinate
 rec_find_all(p, 1, n, δ)
 }
}

rec_find_all(p, i, j, δ) {
 if ($j - i < 3$) {
 sort p_i, \dots, p_j by y-coordinate
 directly find and output all pairs within δ of each other
 return
 }
 $k = \lfloor (i + j) / 2 \rfloor$
 $l = p_k.x$
 rec_find_all(p, i, k, δ)
 rec_find_all(p, k + 1, j, δ)
 merge p_i, \dots, p_k and p_{k+1}, \dots, p_j by y-coordinate
 $t = 0$
 for $k = i$ to j
 if ($p_k.x > l - \delta \wedge p_k.x < l + \delta$) {
 $t = t + 1$
 $v_t = p_k$
 }
 for $k = 1$ to $t - 1$
 for $s = k + 1$ to $\min\{t, k + 7\}$
 if ($\text{dist}(v_k, v_s) = \delta$)
 println(v_k, v_s)
 }
}

12. find_all_2 δ (p, n) {
 $\delta = \text{closest_pair}(p, n)$ // original function
 if ($\delta > 0$) {
 sort p_1, \dots, p_n by x-coordinate
 rec_find_all_2delta(p, 1, n, δ)
 }
}

rec_find_all_2 δ (p, i, j, δ)
 if ($j - i < 3$) {
 sort p_i, \dots, p_j by y-coordinate
 directly find and output all pairs less than 2δ apart
 return
 }
}

```

```

k = [(i + j)/2]
l = pk.x
rec_find_all_2δ(p, i, k, δ)
rec_find_all_2δ(p, k + 1, j, δ)
merge pi, ..., pk and pk+1, ..., pj by y-coordinate
t = 0
for k = i to j
 if (pk.x > l - 2δ ∧ pk.x < l + 2δ) {
 t = t + 1
 vt = pk
 }
for k = 1 to t - 1
 for s = k + 1 to min{t, k + 31}
 if (dist(vk, vs) < 2δ)
 println(vk, vs)
}

```

14. Consider points

$$p_i = (i, (i - 1)100) \text{ for } i = 1 \text{ to } 31 \quad \text{and} \quad p_{32} = (1, 32).$$

The closest pair is  $p_1, p_{32}$  and  $\delta = 32$ . After the closest-pair algorithm is called, the points are sorted by  $y$ -coordinate:  $p_1, p_2, \dots, p_{32}$ . The only pair less than  $2\delta$  is  $p_1, p_{32}$ , which is not found by algorithm *exercise 14*.

15. Replace the code that stores *all* points in the vertical strip for the initial value of  $\delta$  with code that finds the first eight points in the strip (or less if there are less than eight points in the strip). After comparing each point to the next seven points in the strip, store an additional point in the strip (if any) using the updated value of  $\delta$ .

## Section 13.2

2. We use the same notation as in the proof of Theorem 13.2.5. If  $p_1, p_0, p_2$  make a left turn,  $x_1 = x_0$ , and  $y_0 > y_1$ , then  $x_2 < x_0$ . Thus

$$\begin{aligned}
\text{cross}(p_0, p_1, p_2) &= (y_2 - y_0)(x_1 - x_0) - (y_1 - y_0)(x_2 - x_0) \\
&= -(y_1 - y_0)(x_2 - x_0) \\
&< 0.
\end{aligned}$$

Therefore if  $p_1, p_0, p_2$  make a left turn,  $x_1 = x_0$ , and  $y_0 > y_1$ , then  $\text{cross}(p_0, p_1, p_2) < 0$ . In a similar way, we can show that if  $p_1, p_0, p_2$  make a left turn,  $x_1 = x_0$ , and  $y_0 < y_1$ , then  $\text{cross}(p_0, p_1, p_2) < 0$ . Thus if  $p_1, p_0, p_2$  make a left turn and  $x_1 = x_0$ , then  $\text{cross}(p_0, p_1, p_2) < 0$ .

Similarly, we can show that if  $p_1, p_0, p_2$  make a right turn and  $x_1 = x_0$ , then  $\text{cross}(p_0, p_1, p_2) > 0$ , and if  $p_1, p_0, p_2$  are collinear and  $x_1 = x_0$ , then  $\text{cross}(p_0, p_1, p_2) = 0$ .

5. (2, 1), (9, 1), (11, 3), (10, 17), (3, 11)



6. The idea is to insert the added point into the convex hull so that the sorted order, determined by the angle from the horizontal, is maintained. The correct position can be determined and the point can be inserted in worst-case time  $\Theta(n)$ . Next the portion of Graham's algorithm following the sort step can be run, which takes time  $\Theta(n)$ . Thus the convex hull of  $S'$  can be found in time  $\Theta(n)$ . This technique works unless the added point  $q$  is below  $p_1$  or on the same level and left of  $p_1$ , in which case, the points are no longer sorted with respect to  $p_1$ . This problem can be overcome by comparing  $q$  to  $p_1$ . If  $q$  is above or at the same level and to the right of  $p_1$ , we insert  $q$  in sorted order determined by the angle from the horizontal with respect to  $p_1$ , and then run the last for loop exactly as in the original algorithm. If  $q$  is below or at the same level and to the left of  $p_1$ , we insert  $q$  in sorted order determined by the angle from the horizontal with respect to  $p_{max}$ , a point on the convex hull with *maximum*  $y$ -coordinate. We then run the last for loop, with suitable modifications, with  $p_{max}$  as the base point.
9.  $\Theta(n^2)$ , which occurs when all the points are on the convex hull.



## Appendix

# Solutions to Selected Exercises

### Appendix A

$$3. \begin{pmatrix} 5 & 7 & 7 \\ -7 & 10 & -1 \end{pmatrix} \quad 4. \begin{pmatrix} -1 & -6 & -9 \\ 0 & -4 & 2 \end{pmatrix} \quad 6. \begin{pmatrix} -8 & -2 & 4 \\ 14 & -12 & -2 \end{pmatrix}$$

$$7. \begin{pmatrix} 9 & 8 & 5 \\ -14 & 16 & 0 \end{pmatrix} \quad 10. \begin{pmatrix} 46 & -35 \\ -18 & -20 \\ 23 & -2 \end{pmatrix} \quad 11. \begin{pmatrix} -11 & -6 \\ 18 & -8 \end{pmatrix}$$

$$13. \begin{pmatrix} 2a + 4c + e & 2b + 4d + f \\ 6a + 9c + 3e & 6b + 9d + 3f \\ a - c + 6c & b - d + 6f \end{pmatrix} \quad 15. x = 1, y = -2, z = 8$$

$$16. x = 38/5, y = 0, z = -81/5, w = -304/5$$

$$18. \begin{pmatrix} 2 & 1 \\ 1 & 1 \end{pmatrix} \begin{pmatrix} 1 & -1 \\ -1 & 2 \end{pmatrix} = I_2 = \begin{pmatrix} 1 & -1 \\ -1 & 2 \end{pmatrix} \begin{pmatrix} 2 & 1 \\ 1 & 1 \end{pmatrix}$$

19. Let

$$A = \begin{pmatrix} a & b \\ c & d \end{pmatrix}.$$

Suppose that  $AB = I_2$  for some  $2 \times 2$  matrix

$$B = \begin{pmatrix} e & f \\ g & h \end{pmatrix}.$$

We have

$$\begin{pmatrix} ae + bg & af + bh \\ ce + dg & cf + dh \end{pmatrix} = AB = \begin{pmatrix} 1 & 0 \\ 0 & 1 \end{pmatrix}.$$

Now

$$\begin{aligned} (ad - bc)(eh - fg) &= (ae + bg)(cf + dh) - (af + bh)(ce + dg) \\ &= 1 \cdot 1 - 0 \cdot 0 = 1. \end{aligned}$$

Thus  $ad - bc \neq 0$ .

If  $s = ad - bc \neq 0$ , setting

$$B = \begin{pmatrix} d/s & -b/s \\ -c/s & a/s \end{pmatrix},$$

we obtain  $AB = I_2 = BA$ .

21. Let

$$A = (a_{ij}), B = (b_{pq}), AB = (c_{rs}), B^T A^T = (d_{uv}), A^T = (a'_{ji}), B^T = (b'_{qp}), (AB)^T = (c'_{sr}).$$

Then

$$d_{uv} = \sum_{x=1}^k b'_{ux} a'_{xv} = \sum_{x=1}^k a_{vx} b_{xu} = c'_{uv}.$$

## Appendix B

$$2. 4y - 6a \quad 3. -2a + 14b \quad 5. \frac{8x - 4b}{2} - \frac{7x + b}{4} = \frac{16x - 8b}{4} - \frac{7x + b}{4} = \frac{9x - 9b}{4}$$

$$6. \frac{56x^2 - 20xb - 4b^2}{9} \quad 9. \frac{1}{81} \quad 10. 81 \quad 12. 1 \quad 13. 1$$

$$15. 5^n + 4 \cdot 5^n = 5^n(1 + 4) = 5^n \cdot 5 = 5^{n+1}$$

$$17. x^2 + x - 12 \quad 18. 6x^2 + x - 12 \quad 20. x^2 - 8x + 16 \quad 21. 9x^2 + 24x + 16$$

$$23. x^2 - a^2 \quad 24. 4x^2 - 9 \quad 26. (x - 5)(x + 2) \quad 27. (x + 3)^2$$

$$29. (x + 9)(x - 9) \quad 30. (x + 2b)(x - 2b) \quad 32. (3x + 5)(2x - 3)$$

$$33. (2x - 3)^2 \quad 35. (3a + 2b)(3a - 2b) \quad 36. 2(3x - 5)(2x - 5)$$

$$\begin{aligned} 38. \frac{n(n+1)(2n+1)}{6} + (n+1)^2 &= (n+1) \left[ \frac{n(2n+1)}{6} + (n+1) \right] \\ &= (n+1) \left[ \frac{n(2n+1) + 6(n+1)}{6} \right] \\ &= (n+1) \left[ \frac{2n^2 + 7n + 6}{6} \right] \\ &= (n+1) \left[ \frac{(n+2)(2n+3)}{6} \right] \\ &= \frac{(n+1)(n+2)(2n+3)}{6} \end{aligned}$$

$$\begin{aligned} 39. \frac{n}{2n+1} + \frac{1}{(2n+1)(2n+3)} &= \frac{n(2n+3) + 1}{(2n+1)(2n+3)} = \frac{2n^2 + 3n + 1}{(2n+1)(2n+3)} \\ &= \frac{(n+1)(2n+1)}{(2n+1)(2n+3)} = \frac{n+1}{2n+3} \end{aligned}$$

$$41. 2r(n-1)r^{n-1} - r^2(n-2)r^{n-2} = 2(n-1)r^n - (n-2)r^n = [2(n-1) - (n-2)]r^n = nr^n$$

$$43. (3x-2)(2x-1) = 0, \quad x = \frac{2}{3}, \frac{1}{2}$$

$$44. x = \frac{-(-4) \pm \sqrt{(-4)^2 - 4 \cdot 2 \cdot 1}}{2 \cdot 2} = \frac{4 \pm \sqrt{8}}{4} = \frac{4 \pm 2\sqrt{2}}{4} = \frac{2 \pm \sqrt{2}}{2}$$

$$46. -9 > x \quad 47. -\frac{12}{11} < x$$

49. We have

$$\begin{aligned} (1+ax)(1+x) &= 1+ax+x+ax^2 \\ &= 1+(a+1)x+ax^2 \\ &\geq 1+(a+1)x \end{aligned}$$

because  $ax^2 \geq 0$ .

50. We may multiply

$$\frac{5}{2} = 2.5 > 2.25 = \left(\frac{3}{2}\right)^2$$

by

$$\left(\frac{3}{2}\right)^{n-2}$$

to obtain

$$\left(\frac{3}{2}\right)^{n-2} \left(\frac{5}{2}\right) > \left(\frac{3}{2}\right)^{n-2} \left(\frac{3}{2}\right)^2 = \left(\frac{3}{2}\right)^n.$$

52. The given inequality is equivalent to  $0 < 4n + 1$ , which is true for all  $n \geq 1$ .

$$53. 6n^2 + 4n + 1 \leq 6n^2 + 4n^2 + n^2 = 11n^2$$

$$55. -7 \quad 56. 1 \quad 58. 1000 \quad 60. 4.906890596 \quad 61. 15.84962501$$

$$63. -4.736965594 \quad 65. -0.603845495 \quad 66. 99.4300753 \quad 69. 1.336810137$$

$$70. 2.069864223$$

## Appendix C

2. First *large* is set to 8 and *i* is set to 2. Since  $i \leq n$  is true, the body of the while loop executes. Since  $s_i > \textit{large}$  is false, the value of *large* does not change. *i* is set to 3 and the while loop executes again.

Since  $s_i > \textit{large}$  is false, the value of *large* does not change. *i* is set to 4 and the while loop executes again.

Since  $s_i > \textit{large}$  is false, the value of *large* does not change. *i* is set to 5 and the while loop executes again.

Since  $i \leq n$  is false, the while loop terminates. The value of *large* is 8, the largest element in the sequence.

3. First *large* is set to 1 and *i* is set to 2. Since  $i \leq n$  is true, the body of the while loop executes. Since  $s_i > large$  is false, the value of *large* does not change. *i* is set to 3 and the while loop executes again.

Since  $s_i > large$  is false, the value of *large* does not change. *i* is set to 4 and the while loop executes again.

Since  $s_i > large$  is false, the value of *large* does not change. *i* is set to 5 and the while loop executes again.

Since  $i \leq n$  is false, the while loop terminates. The value of *large* is 1, the largest element in the sequence.

5. First *x* is set to 4. Since  $b > x$  is false,  $x = b$  is *not* executed. Since  $c > x$  is false,  $x = c$  also is not executed. Thus *x* is the largest of the numbers *a*, *b*, and *c*.
6. First *x* is set to 8. Since  $b > x$  is false,  $x = b$  is *not* executed. Since  $c > x$  is false,  $x = c$  also is not executed. Thus *x* is the largest of the numbers *a*, *b*, and *c*.

```
8. max(a, b) {
 if (a > b)
 return a
 else
 return b
}
```

```
9. swap(a, b) {
 temp = a
 a = b
 b = temp
}
```

```
11. negatives(s, n) {
 for i = 1 to n
 if (si < 0)
 println(si)
}
```

```
12. find_val(s, n, val) {
 for i = 1 to n
 if (si == val)
 println(i)
}
```

```
14. alternate(s, n) {
 i = 1
 while (i ≤ n) {
 println(si)
 i = i + 2
 }
}
```