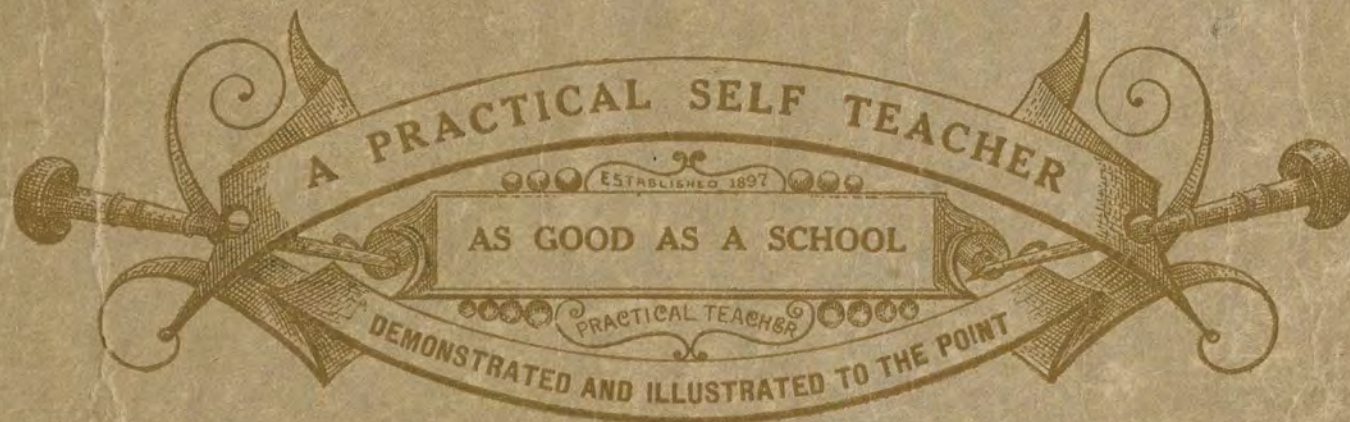


Winter's School of Jewelry Engraving

ESTABLISHED 1897

CHICAGO, ILL.



A COURSE IN

Fundamental Principles of Designing and Engraving



WINTER'S BOOSTER.

The School of Good Things



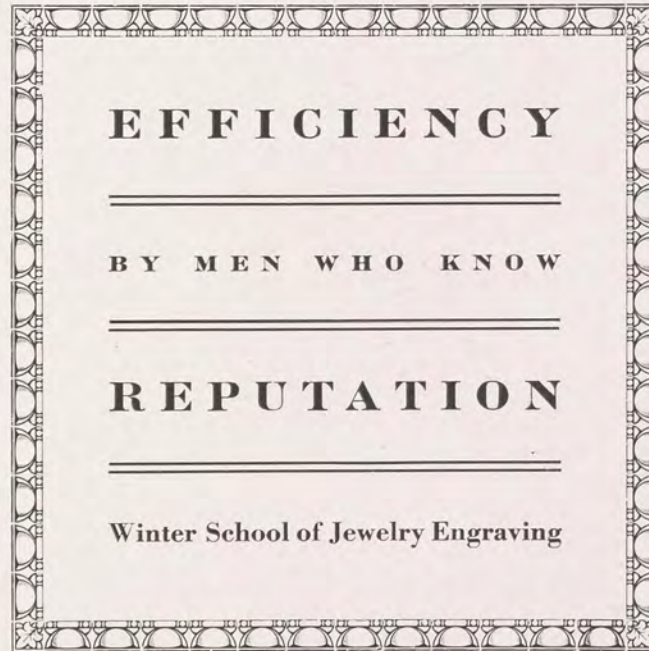
JSL
BK002588

WINTER ENGRAVING COMPANY

THE SCHOOL OF GOOD THINGS



ALBERT A. WINTER
Instructor
Expert on Engraving



Copyright, January, 1915,
by Albert A. Winter.



FRANK W. LOUDENSLAGER
Formerly Watch Instructor at Bradley School,
Peoria, Ill.

CALIFORNIA ANTI QUILLIAN BOOK FAIR

PREFACE

THERE is an almost unlimited field for the practice of the art of jewelry engraving. Every jeweler is being constantly called upon to engrave articles he sells. In most instances he is compelled to send the work to a house which specializes in engraving. This entails delay and expense. Were he able to do his own engraving, he would not only be in a position to make more prompt delivery to his customers, but also reap an added profit.

More jewelers and prospective jewelers would willingly have learned this art, so essential for the successful conduct of the jewelry business were the means at hand. Reliable engraving schools are few and far between. Attendance at them often entails not only the expense of travel and tuition, but absence from home and business. These are obstacles that many have not been able to overcome.

To such, this book affords a happy solution. It brings the methods and teaching of America's most successful school of engraving into their very homes; affords the opportunity of mastering an art whose practice is attended by much pleasure and profit.

PURPOSE OF THE BOOK

THIS book embodied the principles and practices employed with success for very many years in the Winter School of Engraving. Its author, the founder and director of this school, presents in this work the study and experience of a lifetime; not only as preceptor, but as workman.

It presents in brief, simple, concise and comprehensive form, all the authoritative, accepted precepts of the art of engraving upon jewelry. Everything deemed superfluous and irrelevant has been omitted, and only that of practical, everyday utility included.

Consequently, a careful perusal of its text, accompanied by a study of the many charts and illustrations presented, will lead to a broad, practical knowledge of this interesting and lucrative art. To the beginner, as well as to the student advanced in the art, it will prove equally valuable; to the latter, as a means of ready reference. For every phase of the art is thoroughly covered, and answer will be found here to the problems that daily arise in the practice of the art, no matter how skilled the artisan.

GENERAL INSTRUCTIONS

PRACTICE

Jewelry engraving which is done by the correct method is not only easy, but a pleasure as well. If an improper method be used the engraving is difficult and tiresome. It is usually unsatisfactory to every one having anything to do with it. One wishing to learn engraving will find it of advantage to learn how to engrave by the correct method. While it is not possible to become a finished engraver in three or six months, yet much can be accomplished within a comparatively short time if the work be prosecuted under proper conditions.

This budget of copies, with its illustrative cuts and accurate models, cannot fail to simplify the problem for the pupil and shorten his work.

Proper position, accurate forms, correct slant, size and spacing are here clearly and definitely shown. Such a guide is necessary. Instruction by a teacher is desirable. Practice is necessary. Proper use of the budget is imperative if any considerable benefit is to be derived. To succeed, the pupil must take an active interest. He must acquire an accurate idea of the forms to be practiced. He must assume and maintain a proper position and use correct movement. Intelligent criticism is very helpful. Considerable time should be given during practice to comparison of the work done with the copy.

FORM

Form must precede movement. It is necessary to have a form for movement to make just as it is necessary to have a movement to execute the form.

There must be a clear, accurate conception of form before practice begins. This is acquired by close observation of the copy or model. The clearer the picture is in the mind, the better will be the form which is produced.

Intelligent practice shortens the work. There should be observation, then practice and then comparison and criticism. Repeat this again and again until you can see accurate results. Never practice aimlessly or carelessly. You might as well shoot at a mark with your eyes closed.

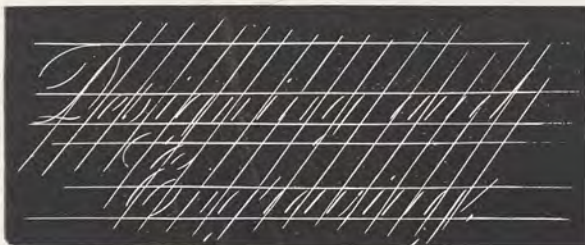
It should be remembered that if you do not adopt correct methods, your practice will do no good; you will not even get started. You must put away old, wrong methods and forms and take on correct ones or your time will be wasted.

ALBERT ANDREW WINTER,
Instructor.

Pertaining to all Lettering and Monograms.

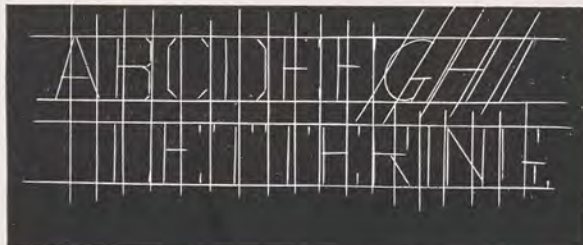
DESIGNING CHART FOR SCRIPT, BLOCK AND OLD ENGLISH LETTERING

Script



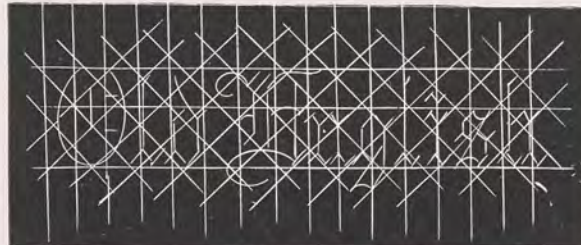
Angle of 45 Degrees

Block



Vertical Guide Lines

Old English



Vertical Guide Lines

CORRECT METHOD USED IN DESIGNING

The above charts pertain to designing only.

Do not fail to employ the guide lines at all times while designing. All lines should be drawn lightly in single line.

Engraving of same is done systematically. For example: In script, all shades are cut up and down; hairlines should be filled in last with graver. In Block, all vertical bars are cut first, all cross cuts last. In O. E. letters, all bars are wriggled first, squares and curves last; hairlines completing letters. This is the only correct way to design and engrave all lettering. Note.—Follow arrows closely; they indicate the cut. See pages 8 and 11. Script Alphabet.

Too much practice is as bad as not enough. Adhere to this.

Good Results can only be obtained by a few hours of daily practice for several or more months, and then keeping constantly at it to obtain desired results.

LIFE, GRACE AND BEAUTY

Note.—In designing names of various styles of lettering it is not essential to draw the letters out in complete form. Only the spacing of the main shade lines is necessary for a guide to cutting. This will develop speed and avoid stiffness and clumsiness.

Note for Demonstration, see page 9.

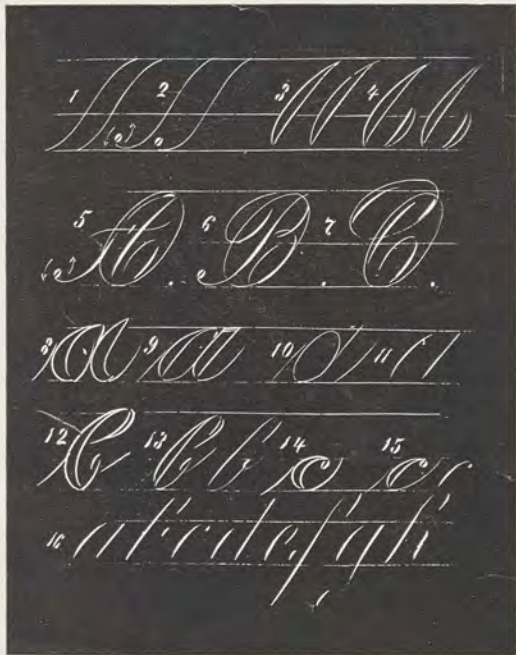
FORM AND HABIT

The art of designing is only mastered by accuracy; in making it a point to do it, is what brings results and is what counts—always drawing as lightly as a feather with as little pressure as possible, using only extra pressure when heavier designing is wanted. When working designs into detail and accuracy—observe this rule at all times.

FIRST LESSONS IN SCRIPT FOR BEGINNERS

Fundamental Principles—Practice Exercises

Plate 1



Figs. 8, 12, 14,
showing wrong way
of cutting small letters.

Avoid curving.

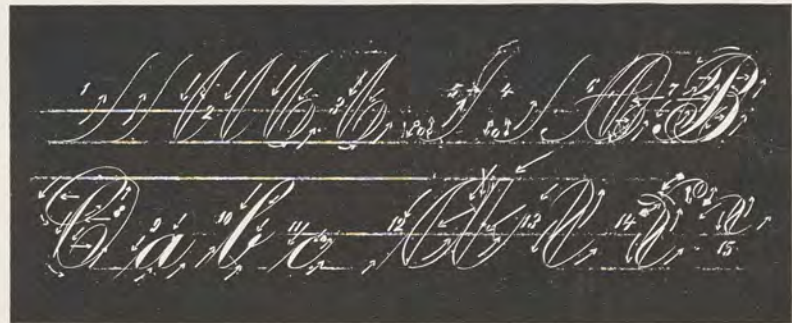


Plate 2

Figs. 6, 7, 8,
showing formation
of the capitals.

Plate 1,

showing Figs. 5,
6, 7, shades first
cut.

First Week, Plate 1, First day—Figs. 1, 2, first half day. Second half day, 3, 4, changing alternating from hairlines to shades. Second day, Figs. 5, 6, 7, and reversing to Figs. 1, 2, 3, 4, back to 5, 6, 7. Third day, the same. Fourth day, 5, 6, 7, adding hairlines. Fifth day, engraving of small letters, Fig 16, a, b, c to h. Sixth day, double cuts, Plate 2, Figs 13, 14, 15. Second Week—First day, designing and spacing of the script letters; some cutting, Figs. 5, 6, 7, and small letters, Fig. 16, a, b c to h. Second day, designing and cutting, taking letters, capitals A to F. Third day, same lesson. Fourth day, reversing cutting, Figs. 1, 2, 3, 4, Plate 1, and double cuts, Plate 2, Figs. 12, 13, 14, 15. Fifth day, designing of capitals A to F, and small letters, Fig. 16, A to H. Sixth day, repeat this. Third Week—Start with capitals G to L, etc. One month required for study of script which will give good results. For other studies in Script, Block and Old English, see Chart Pages 9, 10, 13.

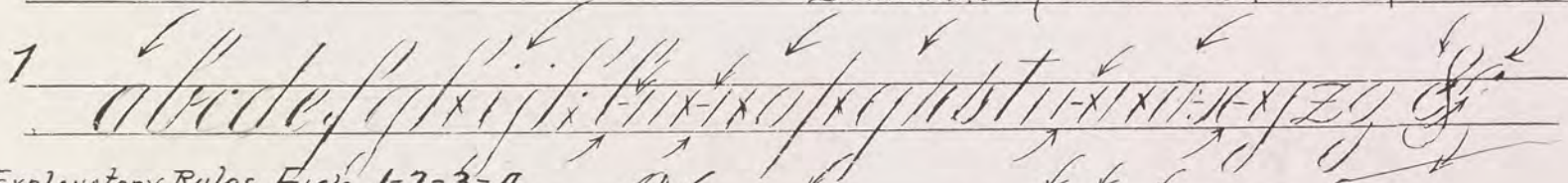
STUDIES IN SCRIPT.

System in following Designing

Code - The line \swarrow indicates the double cut.

SPACING OF SMALL SCRIPT letters
Filling in of the hair lines with GRAVEL.

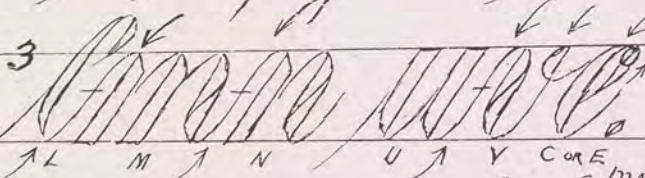
" " \swarrow " to CUT hair line UP & DOWN. 5
ARROWS SHOW
DOWNWARD MOTION IN SKETCHING letters.



EXPLANATORY RULES FIG'S. 1-2-3-4

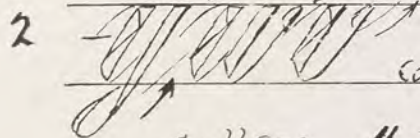
y-v-or-w.

Small letters, cut double or single,



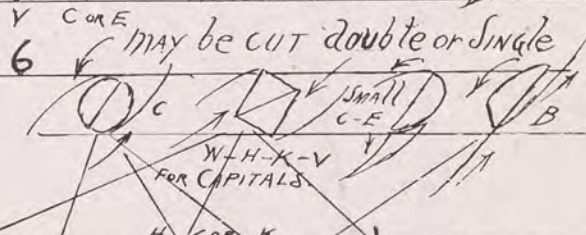
ROUND SQ OVAL

The DOT \circ \square \circ \square \circ \square \circ \square



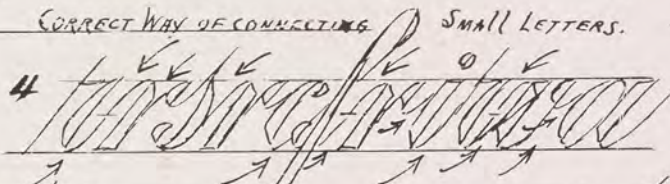
CORRECT WAY OF CONNECTING

SMALL LETTERS.

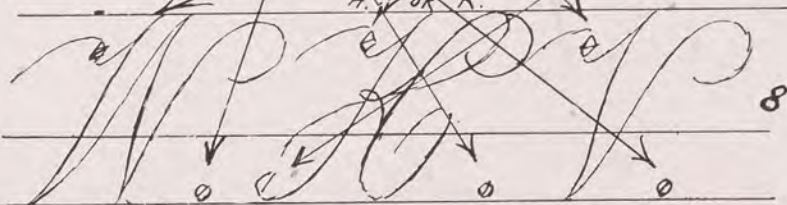


MAY BE CUT DOUBLE OR SINGLE

SMALL (R) 2d style.



7



8

GUIDE LINES

ANGLE OF 45 DEGREES -

Ready For ENGRAVING

Also used For PERIODS.)

EXPLANATORY RULES FIGS. 5-6-7-8.

Script Practice after Preliminaries—Fourth Week.

Aa Bb Cc Dd Ee Ff Ff
Gg Hh Ii Jj Kk Ll
Mm Nn Oo Pp Qq Rr
Ss Tt Uu Vv Ww Xx
Yy Zz 8 1234567890
Aa Bb Cc d d d



Fig. 1



Fig. 2

PRACTICAL ILLUSTRATION

Six-inch pad, cement block, copper plate, for Practice Work. Fig. 1 shows how to hold the graver for cutting Script on edge of block. Fig. 2 shows how to hold the graver for cutting Script in center of block and other large articles which are flat—also Monogram and Inscription Work. Again Fig. 1 shows how to hold graver to engrave Signet Rings, Locketts, Watch Cases, and similar small articles. Note, the thumb is not usually extended as far out—more like Fig. 2. The square graver is also used for finishing Block, Old English lettering, Close-lined and Block Monograms. Rule for Cutting: Push the graver slowly, holding and turning the cement block slightly, sometimes stationary. For Monogram Work it is turned in circular motion. Pad must not be turned.



FIG. ONE
Coarse Wriggling, Angle 20 Degrees, 36-37-38 flat,
for Block and Old English Letters.

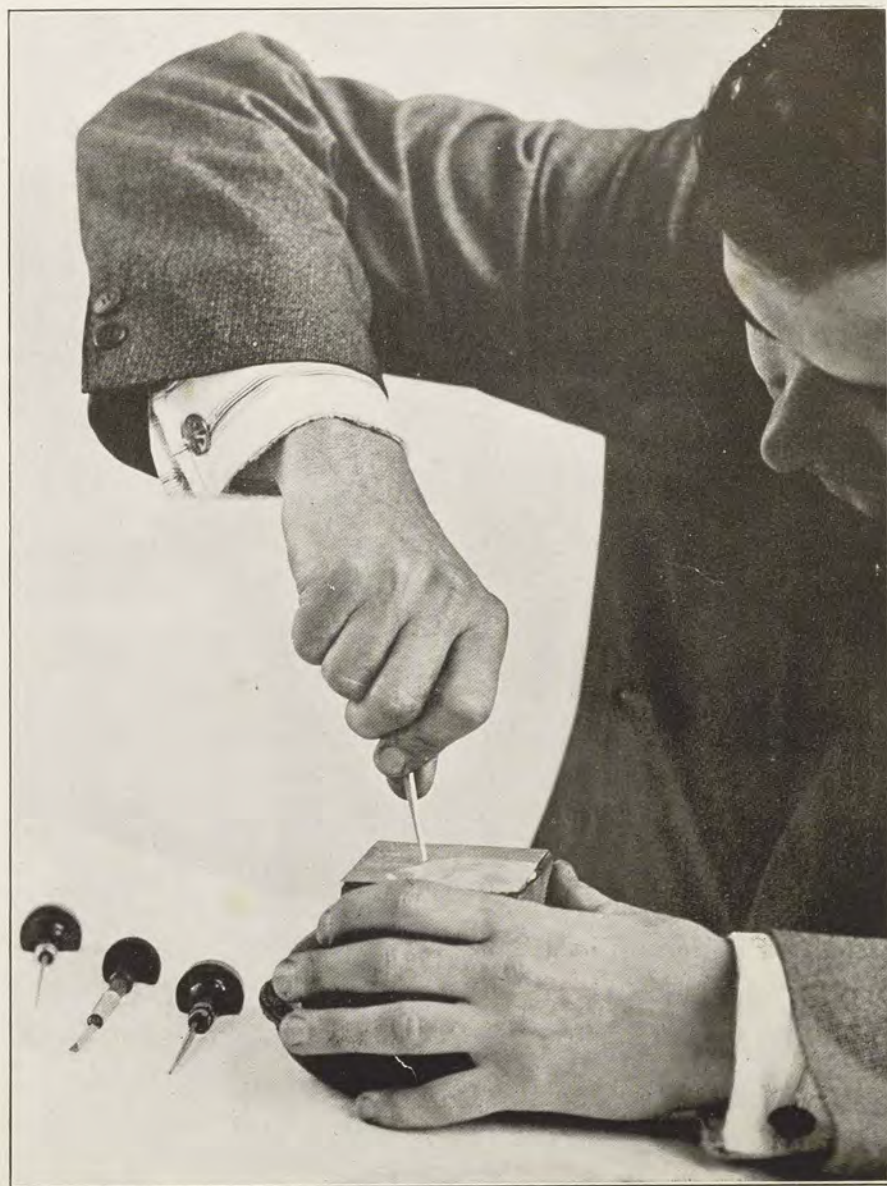


FIG. TWO
Fine Wriggling, Angle 65 Degrees, 37-38-39-40 to 46 flat.
Drawing the Graver to Fine Point for Old English Letters.

KEY TO ALL LETTERS

Script Alphabet

Fig. 1 shows correct way of cutting shade; notice shade cut straight down to line.

Fig. 2 shows incorrect way of cutting shade; notice shade curved far above lower line which breaks off point of graver on account of turning or twisting of cut.

Figs. 3, 4 and 5 show the way to lay out, and form a graceful letter.

Fig. 6 Double cut complete, and how to cut same.

Fig 7 shows how to cut around dot. First cut black shade up, then cut white shade down.

Fig. 8 illustrates distinction between shades which are pointed and shades which are square at top.

Fig. 9 shows how to cut the Fig. 8—cut the white shade first, beginning at the bottom of line. And then commence at the top cutting the black down, making a double cut, tapering it to a point, cutting diagonally.

Fig. 1. In cutting either shades or hair lines follow the arrows as per directions on copy.

Fig. 2. When cutting shades, lay graver towards right.

Fig. 3. Hair lines are light, shades are heavy, as you will notice in copy plate.

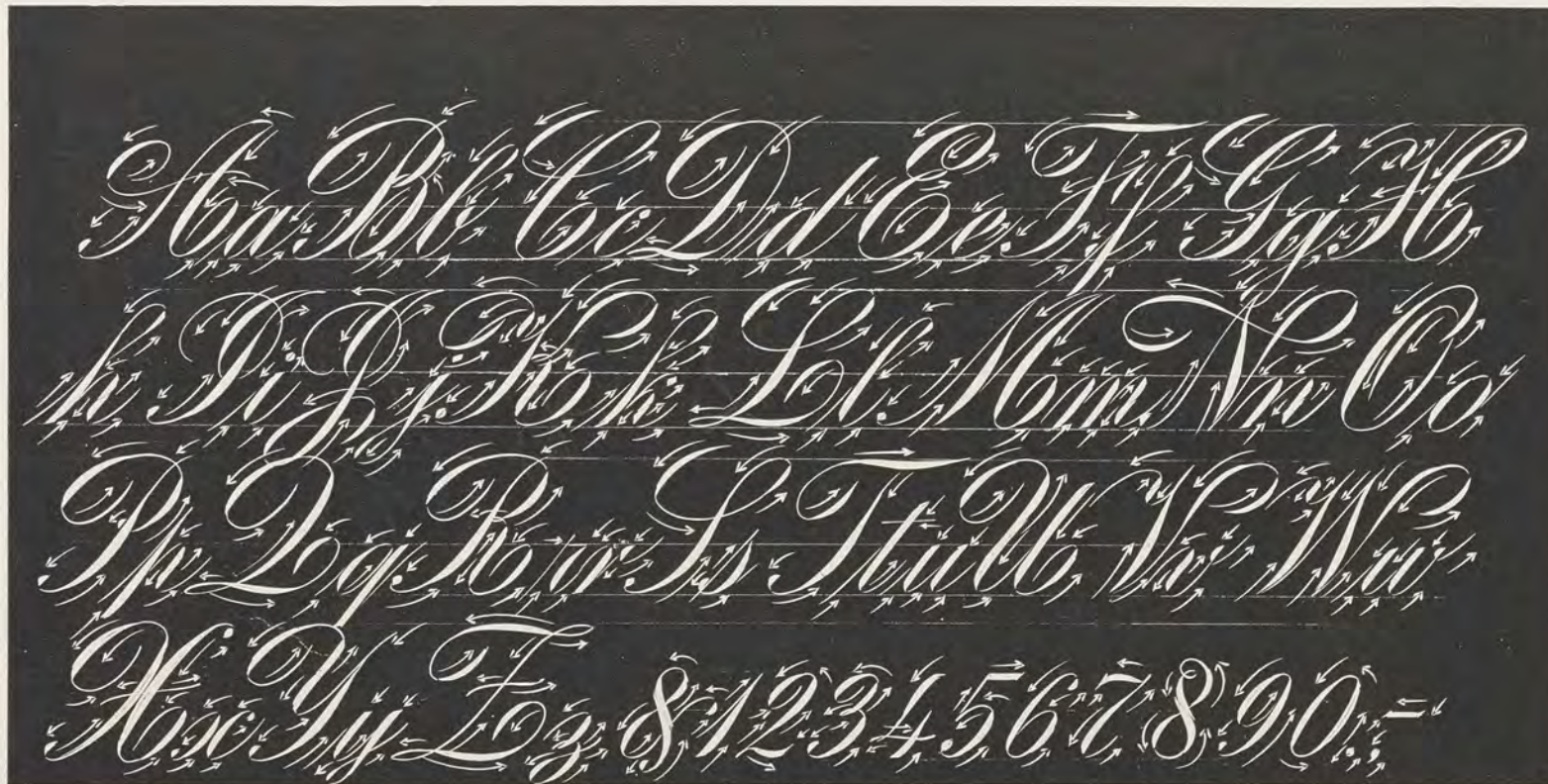
Fig. 4. Slant of letters must parallel and spacing must be evenly divided, as you will notice.

Fig. 5. When putting plate on cement block heat plate holding it with plyers over alcohol lamp or gas, then lay it down on cement block and allow it to cool before cutting.

To cut and make shades, square at beginning, as for example at the top of certain letters, such as small **a**, **d** or **g**, or the bottom of such letters a small **f** or **p**, place point of graver at top of line, lay it over to right and then cut down, and that will make the shade square at the top as you will notice in copy plate, page 10.

SCRIPT LETTERING

Standard for Correctness of Style, Grace and Beauty



ENGRAVING SCRIPT ON SMALLER ARTICLES OF GOLD, GOLD FILLED AND SILVER


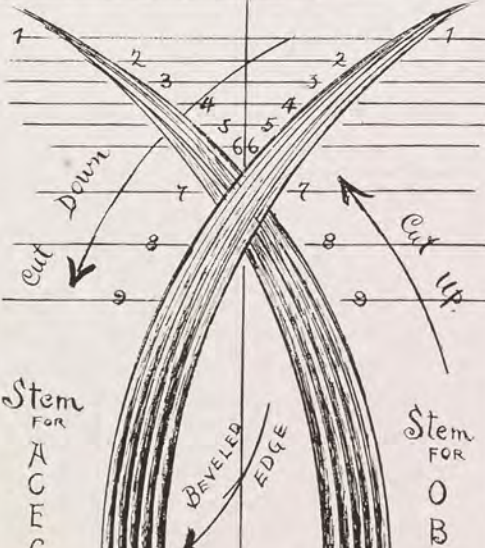
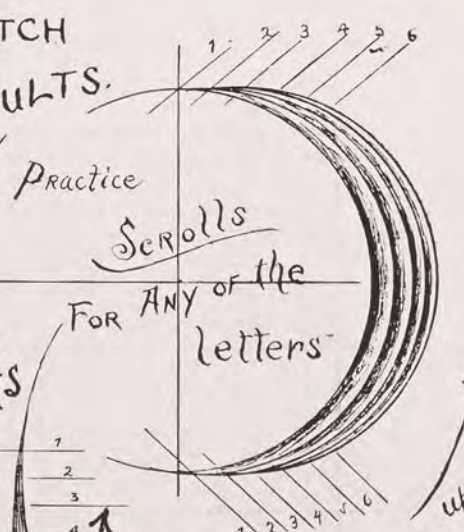

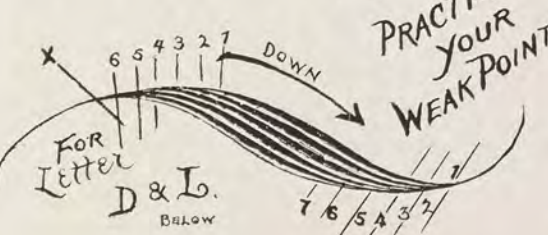
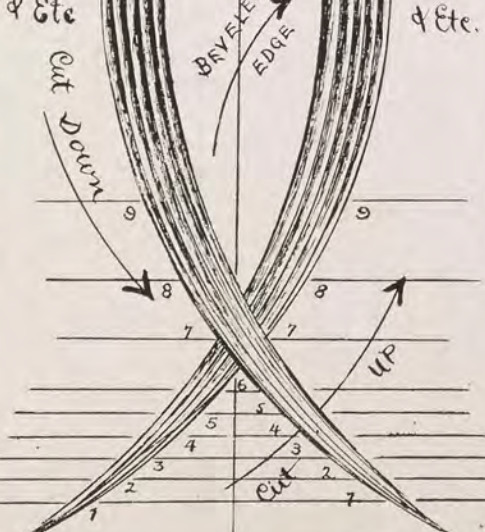
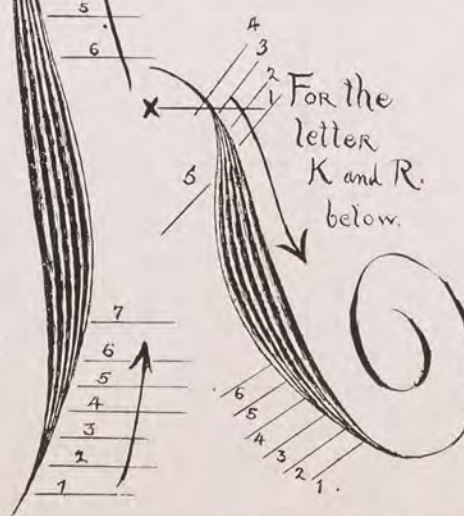
such as silver spoons, the inside of watch cases, rings, bracelets, napkin rings, charms, medals, class pins, etc.

As these articles consist of different metals, they must be either solid cut, or close lined, according to thickness of metals. Bright cutting on cheap filled goods and all hard metals cannot very well be done.

It is only possible to engrave a smooth cut.

ENGRAVING SHIELDS ON CARVING SETS

of silver, nickel or German silver. The same rule holds for these as for the smaller articles enumerated in the above paragraph.

<p>Note TO GAIN SPEED</p> <p>DOWN 5 4 3 2 1</p> <p>Practice GO SCROLLS FOR ANY OF THE LETTERS. SLOW TAKE PAINES</p> 	 <p>Stem FOR A C E G & Etc</p> <p>Stem FOR O B R & Etc.</p>	<p>WATCH RESULTS.</p> <p>Practice SCROLLS FOR ANY OF THE LETTERS</p> <p>FOR YOUR EFFORTS</p> 
<p>TOP OF Letter</p> <p>1 2 3 4 5</p> <p>up</p> <p>5 3 2 1</p> <p>T.W.K.H.</p> <p>PRACTICE YOUR WEAK POINTS</p> <p>FOR Letter D & L. BELOW</p> <p>6 5 4 3 2 1</p> <p>DOWN</p> <p>7 6 5 4 3 2</p>  		<p>Stem FOR B D F T H I J & Etc.</p> <p>FOR the letter K and R. below.</p> 

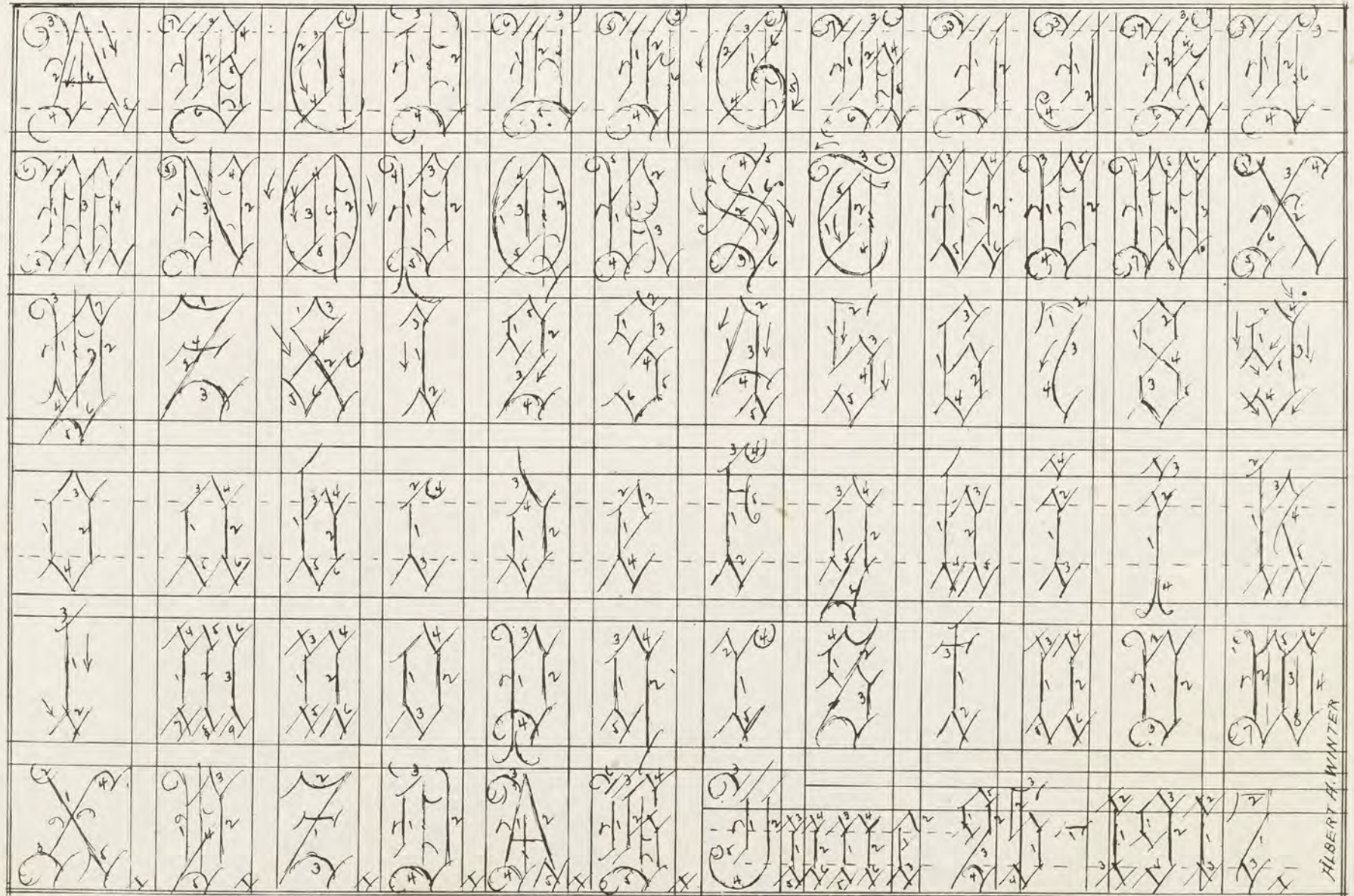
Albert A Winter

9-5-1917.

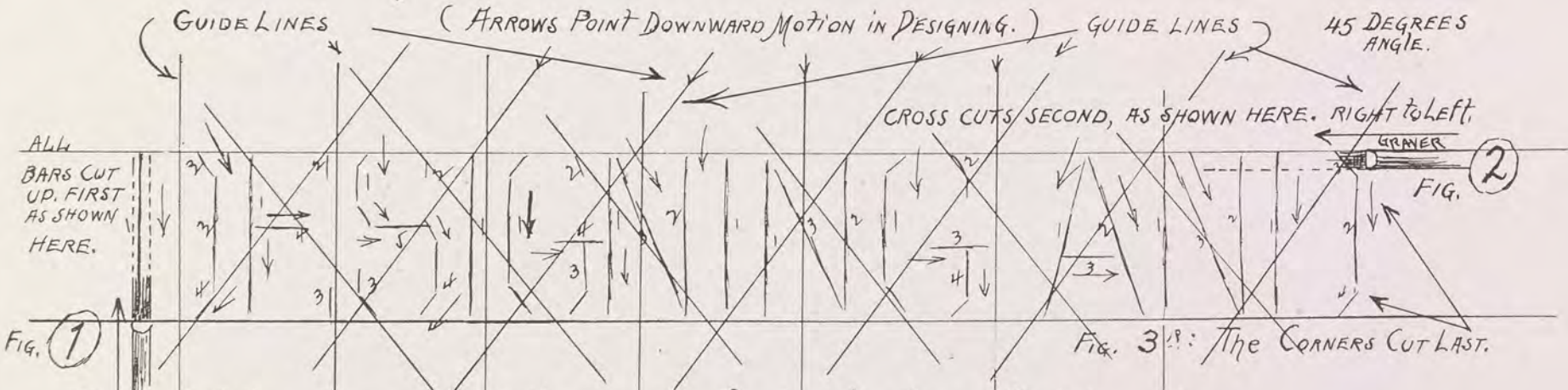
Chicago Ill.

For Closeline Script and Monograms of Any Description

METHOD OF DESIGNING OLD ENGLISH FOLLOWING NUMBER IN ROTATION



BLOCK AND OLD ENGLISH LETTERING.



RULES to follow DESIGNING of LETTERING.

Single Hairline Sketch only.

for ENGRAVING, PLACING of the GRAVER. AS SHOWN IN FIGURE 1- AND 2 - Also for Old English

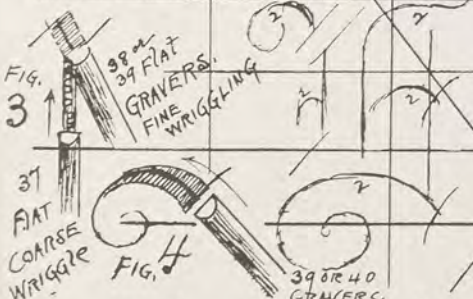
FOR EXAMPLE -

FOR HAIR LINES N^o 1

FOR SQUARES N^o 2

FIGURE 3 AND 4.
DESIGNING of O.E.
Old English Letters
follow SAME SYSTEM
AS BLOCK.

Guide lines N^o 1
for HAIR lines
Guide lines N^o 2
for SQUARES &
CURVES.



Explanatory Code -

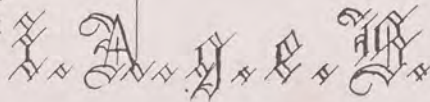
LIGHT SKETCH

LETTERS COMPLETE

THUS → BARS HEAVY | SKETCH.

SQUARES AND

CURVES



DESIGNING THE VARIOUS STYLES OF LETTERS

usually difficult to beginners, is rendered very simple by our method which can be mastered by a little everyday practice in a remarkably short time. In all designing, the first thing to do is to draw **very lightly**. By means of good paper, a soft and a hard pencil, a piece of art gum and close observance of the principles of our method, this important step in designing ceases to be difficult.

In designing letters or monograms, begin by drawing a single line sketch of lettering or monogram in the rough. Then follow with the shaping up or modeling of same, as shown in charts, pages 23, 28, 30, 32, 39, 40, 45, 47, 48.

Carefully preserve the slant of the lettering or the balancing of the monogram, being particular not to run together the shadings which are the beauty lines.

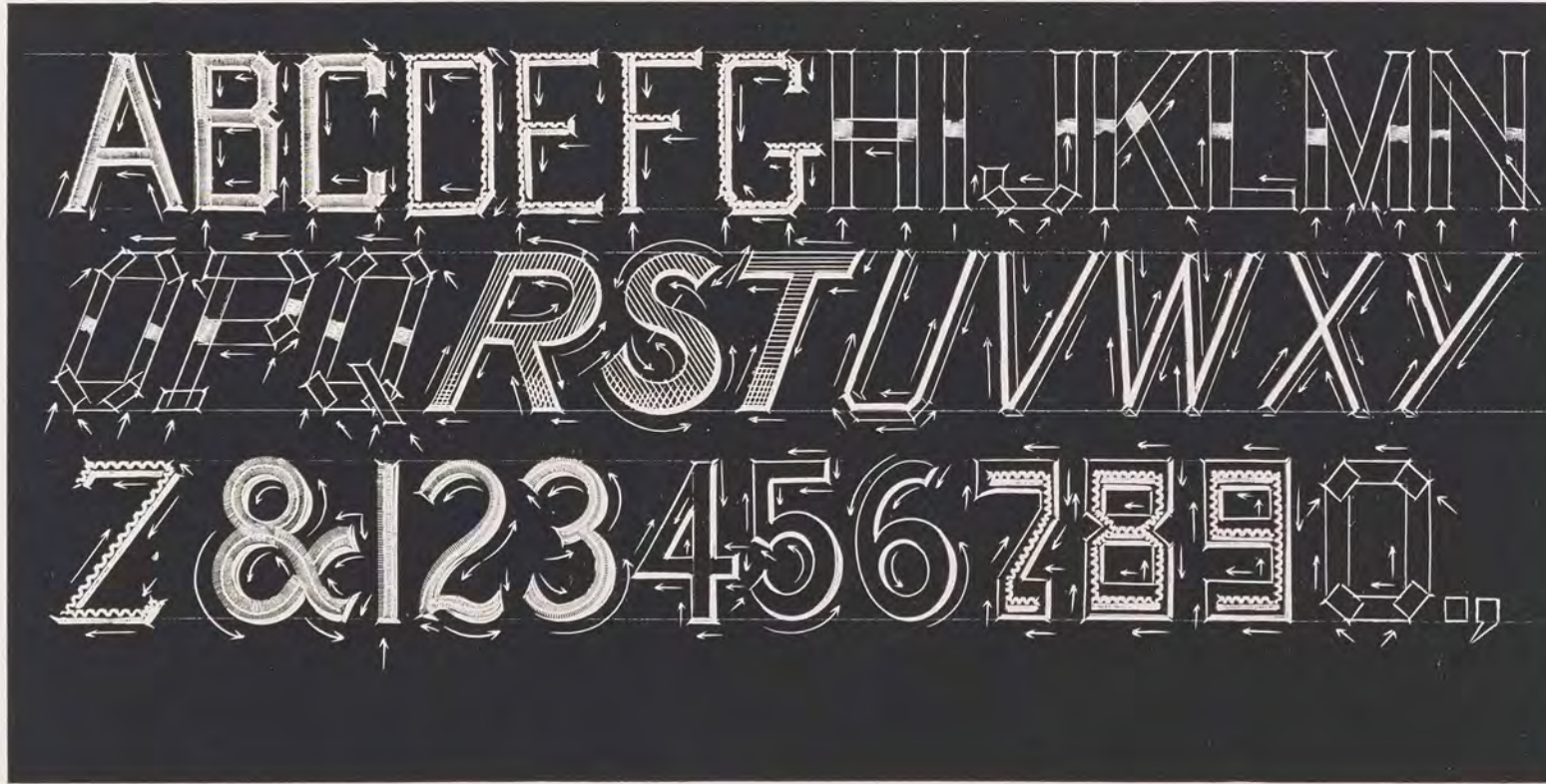
DESIGNING LARGE MONOGRAMS ON WATCH CASES

First find the center of the case with the dividers. Draw a line up and down. Leave plenty of margin around the design, about one-fourth of an inch.

ENGRAVING SMALL MONOGRAMS ON VARIOUS DIFFERENT METALS

Monograms one-half inch in size, or smaller, are best bright cut engraved. Those over one-half inch should be close line engraved. If the metal is soft they can be bright cut, whatever their size. Close lining, however, will look good.

BLOCK LETTERING



Designed and Engraved in Various Styles as per Demonstrations, According to Different Sizes, on Different Metals

Figures Styles 4, 5, 6. Design as with R S T. Engrave in same manner. No crossline shading. Shading on right hand side in closeline, or bright cut for smaller letters. The shading should be done inward from the outline straight, and outward from the curved line and inward from the curved line, as shown in the chart and indicated by heavy white lines.

BLOCK—Continued

Style O, P, Q. Design and engrave as with styles H to N.

Proceed with sketching words and initials, as shown on chart (Block and Old English) lettering, properly spacing the work, which is then ready for cutting.

Style R, S, T in **cross line shaded block**. Design letters in rough skeleton sketch in single line. Design a line on each side of middle line already drawn, shaping letter into a double line letter, similar to O, P, Q.

To engrave cross line shaded letters, first outline with hair line; second, shading letter on right side as shown in chart; third, cross line the letters from the white shades to the hairline. Use guide lines for all letters to keep them on the same angle.

BLOCK LETTERING

Small lettering is most appropriate for such articles as watch caps, charms, class pins, medals, etc. The flat gravers used for these articles are Nos. 36, 37, 38 for one size cuts, as shown in Block Chart H to N. Use No. 37 for the up and down bars and No. 36 for cross cuts and picking the letters at the corners. Larger letters may be engraved the same way with a No. 38 for the bars and No. 37 for cross cuts and they can be engraved dull or bright, as desired.

The same letters may be engraved in a combination Roman Block, using the 37 for the bars up and down, and 36 for the cross cuts, which makes a nice looking letter.

Any capital letter standing for an abbreviation, when engraved on any article must show a period after it, as for example: A. A. W., standing for Albert A. Winter.

Dates, for instance, like June 25, 1915, should show a dash between the day and the year. The figures should always be smaller than the capitals, as shown in charts and plates of Script, Block and Old English lettering.

LARGE BLOCK LETTERING

Style A, B, C. First, fine wriggle; second, coarse wriggle over fine; third, either bright cutting the shades in close lining or dull effect. If dull lining is used a little bright cutting will add the life to the letter.

Style D to G. Coarse wriggle, using lining graver; bright cut or shade for small lettering, and for large work proceed as Style A, B, C.

Style H to N, in plain block, may be engraved in any size, using gravers Nos. 36, 37, 38 and no larger. A touch of a little fine wriggling in the bars as shown will make a pretty effect. If larger block is desired it should be engraved in style R, S, T, or A, B, C.

Style U to Y. First design letter in single line. Use lining graver No. 8-10. Cut a hairline around the letter to appear like a shade on the right side of it.

Style Z. Design letter; then coarse wriggle, using lining graver.

Style "&," "Etc," and Figs. 1, 2, 3. Design; fine wriggle; coarse wriggle over fine; closeline shade in dull or bright (which preferred). If smaller letters are desired, engrave the same way, with the exception that shades are bright cut in one cut, the fine wriggling dull cut with unpolished graver; coarse wriggling should be bright cut.

Style 7, 8, 9. Design as with Figs. 4, 5, 6, and engrave in the same manner. Engrave shades with lining graver, No. 8-10. Between the two hairlines coarse wriggle with liner. Bright cut under coarse wriggling.

Crossline shaded block R, S, T.

2: Draw a single line on each side of line already drawn. Engrave, first, a hairline outline; then closeline the shades which are heavy, and show white on display plates and black on charts.

3: Crossline the letter, using a few guide lines to insure that all lines run at the same angle. The crosslines should run from the white or black shades to the hairlines. Engrave in dull, flat style. No polish to graver, except for bright cutting. This brings out a contrast.



Display Plate No. 1

OLD ENGLISH

Style A to E. Design letter. Coarse wriggle bars with polished graver. Fine wriggle squares and curves. Closeline shades of bars dull, hairlines completing letter. Fine wriggling should be done with unpolished graver. Shades should have beveled edges to the right and a little bright cutting added to give life to the letter.

Style F to J. Design and engrave as with styles A to E, with the exception that shades may be cut on the curves and squares in bright cut. Start closelining the bars from the right of the letter and work toward wriggling, next coarse wriggle with No. 37 polished flat graver over fine as shown.



Display No. 2

OLD ENGLISH—Continued

Style K to O. Design. Engrave as with style F to J, with the exception that letter O, being a single line design, should be engraved with a hairline outline and then closelined in dull effect with a bright shade on its right and left curves. Coarse wriggling the bar only, called closelined O. E. letter. All other letters may be engraved in similar manner, omitting fine wriggling.

INDIVIDUAL OLD ENGLISH LETTERING

Style Combination letter S: Closeline leaf with cross line shaded curves.

OLD ENGLISH—Continued



Display Plate No. 3

DESIGNING AND ENGRAVING OF THESE LETTERS

1. Single line drawing of letter with leaves placed at bars, then a line drawn below the curved line at the top and a line above the curve below, as shown in chart. Shades are close lined. Lines, equally spaced, are filled in.
2. Hairline outline of letter; next close lining of bars.

OLD ENGLISH—Continued

TO DESIGN AND ENGRAVE THESE LETTERS

1. Single line drawing of letter with leaves placed at bars, then a line drawn below the curved line at the top and a line above the curve below, as shown in chart. Shades are close lined. Lines, equally spaced, are filled in.

2. Hairline outline of letter; next close lining of bars.

3. Filling in of leaves, the fine lines, shading effect.

4. Bright cutting of shades on the concave sides.

Style crosslined shaded letter capital T: 1. Design of letter, same as in letter S. 2. Draw a single line on each side of line already drawn; engrave first a hairline outline; then closeline the shades which show the heavy white lines. 3. Crossline the letter, using a few guide lines to insure that all run at the same angle; the crosslines should run from the white shades to the hairline; engrave in dull, flat style, no polish to graver, except for bright cutting; this brings out a contrast.

Style U to X. 1. Design the letter. 2. Coarse wriggle the bars with bright polished graver. 3. Fine wriggle squares and curves. Shade with a lining graver with a sort of wriggle effect, using lining tool No. 8-6.

Style Y. First design letter; then engrave as with U to X with the exception that the shading should be done with a lining graver, cutting down along the sides of the bars, using lining tool No. 8-6.

Style Z and Figs. 1, 2, 3, 4, 5, 6. First design. Then engrave as with U to X, with the exception that the fine wriggling should be afterward coarse wriggled over the fine with a No. 37 flat polished graver.

Style 7 to 0. Handled the same as 1 to 6. Design, then engrave both bars coarse wriggled, one with a bright tool, the other with a dull lining tool, No. 8-6.

Style showing name: "Winter." First design, then engrave as with style U to X. Note spacing of word in its Old English lettering and how well it looks in the finish. Any other style of letter may be employed.

Note—The size of gravers mentioned herein are used for large Old English only; for smaller work use smaller size gravers in proportion.

F TO J OLD ENGLISH

1. Coarse wriggle the bars with a 37 or 38 flat graver.
2. Fine wriggle the curves and squares with a 40 to 42 flat graver.
3. Closeline shades along side of bars, cutting towards the wriggle from the right, cutting down, as shown by arrows. The O. E. G., as shown, has a coarse wriggle over the fine which is done last; this may also be done on other letters if preferred.

ENGRAVING CHAFING DISHES

Where script or Old English is wanted, it should be close lined, the Old English being cut in styles like F to J., according to size of letter. (See Old English Chart.)

1. Coarse wriggle bars with 36 or 37 flat graver, polished.
2. Fine wriggle with 38 or 39 flat graver, no polish.
3. Closeline the shades along side of bars as shown, or the better way is to use a narrow lining tool to shade, which has a pleasing effect and is easier to do.

ENGRAVING PLATED WARE, ROGERS, ALVIN AND R. WALLACE GOODS

Old English letters should be wriggled like styles A, B and C. Use lining tool, somewhat bent for shading bars, and to overcome the pins or any obstructions which the graver might run up against and thereby causing slips. This style of cutting gives a very pleasing effect, using lining tools No. 8-6, according to different size letters.

ENGRAVING HARD METAL GOODS

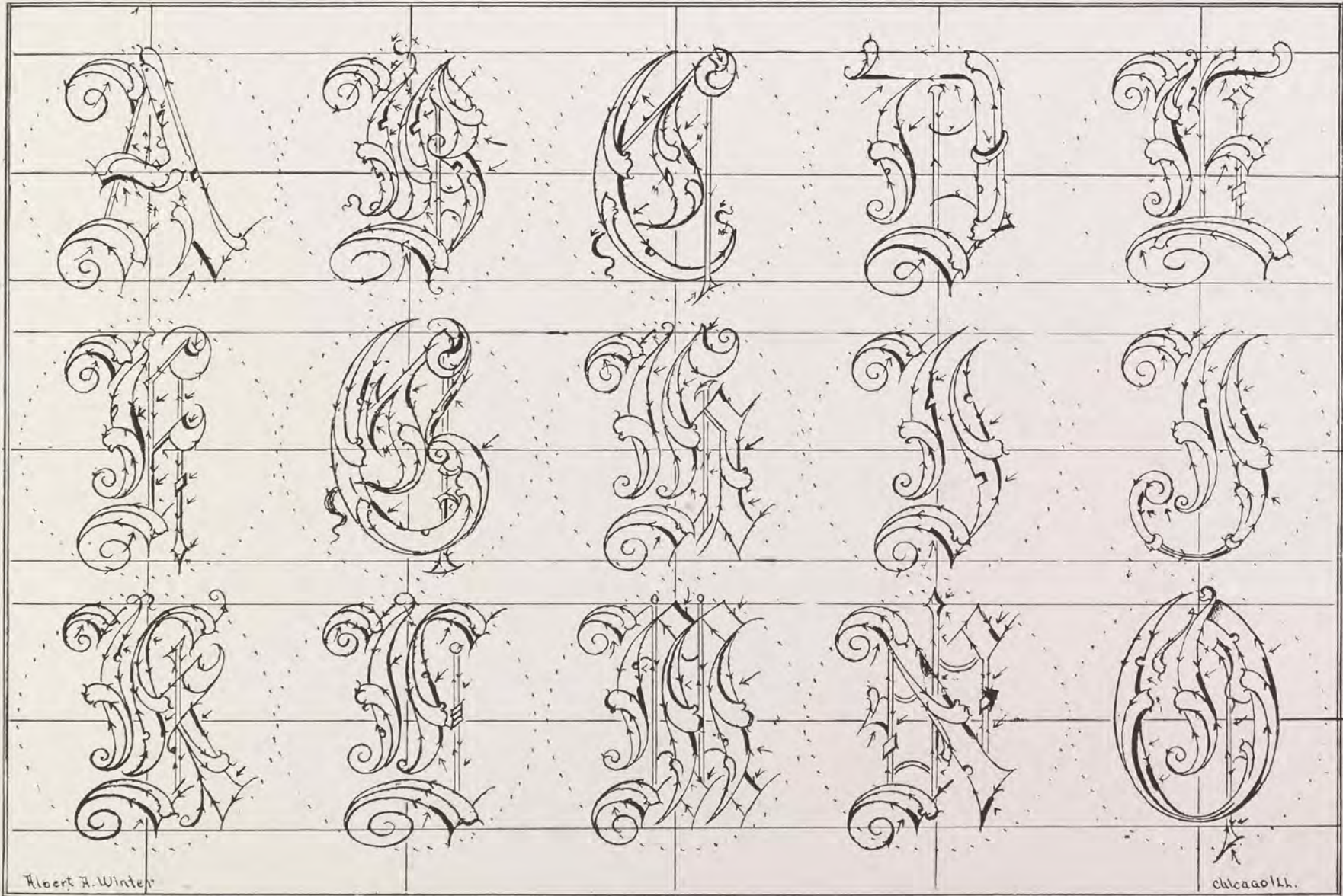
Employ large Old English letters from one to one and one-half inches in height. Bars should be fine wriggled. Flat, unpolished graver should be used, preferably Nos. 42, 44, 46 gravers. Next, coarse wriggle over the fine wriggle with No. 38 over the No. 42; wriggle 38 over the No. 44 and 38 over the No. 46. Finish with close line shading along the sides of bars.

ENGRAVING SOFT WHITE METAL GOODS

Large Old English letters are employed to best advantage. The most pleasing effects are secured by coarse wriggling with a large size lining graver. Fine wriggle squares and curves with Nos. 40, 42, 44, and 46 flat gravers. Then coarse wriggle over the fine wriggle. Shade with a bright cut along sides of bars, curves and squares.

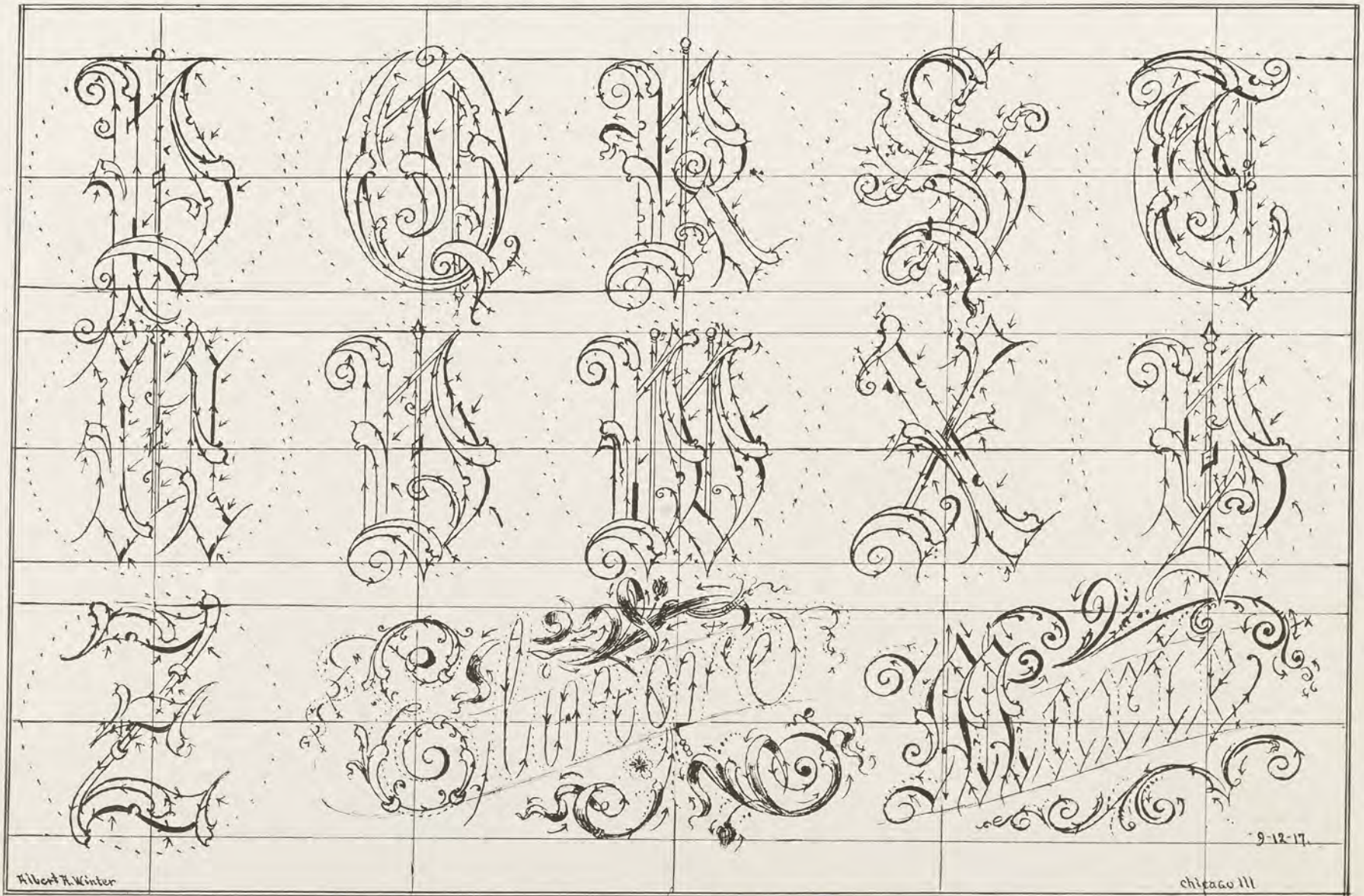
ENGRAVING HARD METAL GOODS IN BLOCK LETTERING

Styles A to G, shown in chart, are best adapted for this work. Use a No. 42 flat graver, unpolished. First fine wriggle. Next, coarse wriggle through center of letter, or its side, if preferred, as in Figs. 1, 2, 3. A block letter is exceptionally good for such articles as Loving Cups, Nickel Vanity Bags, German silver goods and Dog Collars.



Albert H. Winter

Chicago Ill.



Albert R. Winter

Chicago Ill

9-12-17.

Fancy Names for Cutting on Metal as well as on Ivory and Tinting

METHOD USED FOR DESIGNING OLD ENGLISH LETTERS, (DOUBLE LINED)
CROSS LINE SHADED WORK, AND CROSS LINE LEAF WORK.

FIG 1 SINGLE LINE SKETCH

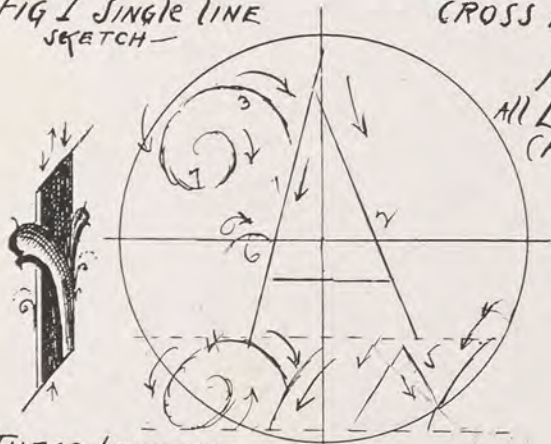


FIG 2 ALL LINES MARKED (A): NEXT.

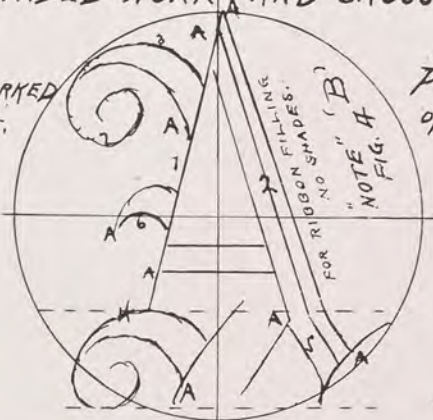
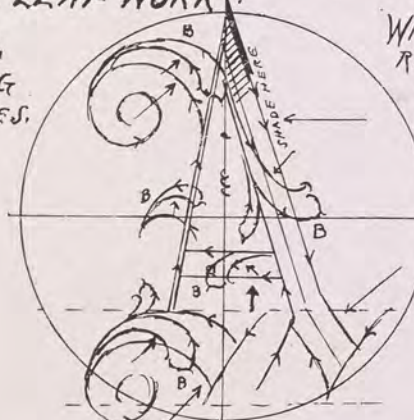


FIG 3. PLACING OF LEAVES.



WHICH IS NOW READY FOR CUTTING FOLLOWING THE ARROWS AS SHOWN. ALL OTHER LETTERS IN THE SAME MANNER.

THESE LETTERS MAY ALSO BE ENGRAVED IN CLOSE LINE AND RIBBON FILLING.

Note the Filling - THESE letters are all out lined first. THE SHADING OF THE LETTERS IS DONE 2ND THE HAIR LINES ARE CUT 3RD, THE FILLING IN OF THE LEAVES 4TH, SHADING OF THE LEAVES LAST, WHICH ARE THE BLACK LINES.

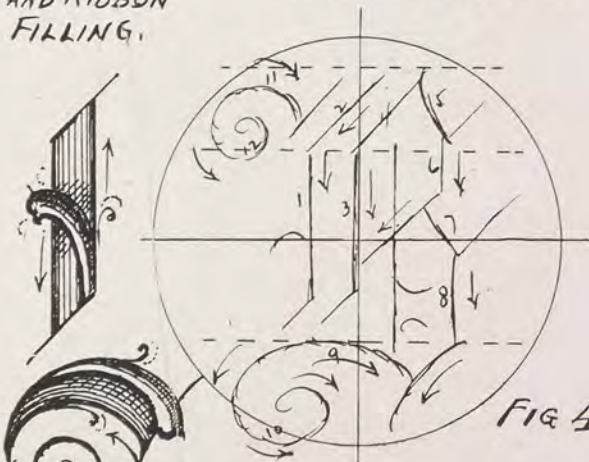


FIG 4

FIG 5

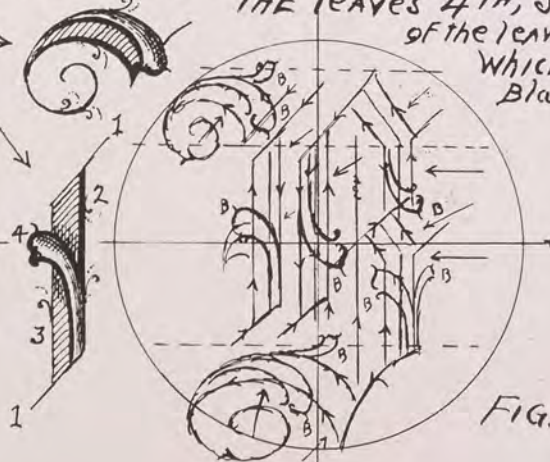
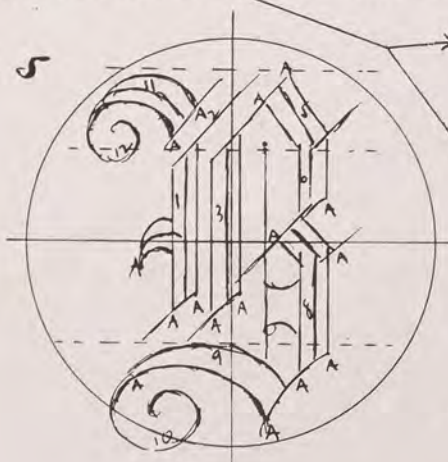


FIG 6



In **designing leaf script**, a light, rough skeleton outline, properly spacing letters and placing leaves. Then cut as with other monograms.

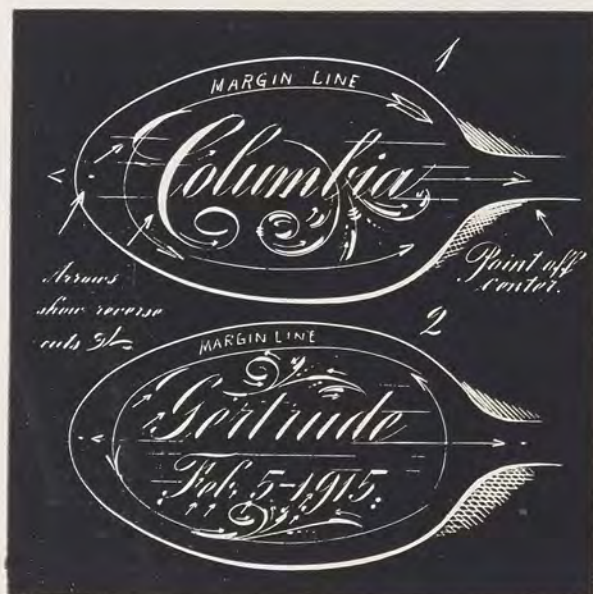
Old English letters are also to be handled as above. In engraving, outlining comes first, close lining follows, then filling of leaves and finally the bright cutting.

THE DESIGNING OF OLD ENGLISH LEAF LETTERS

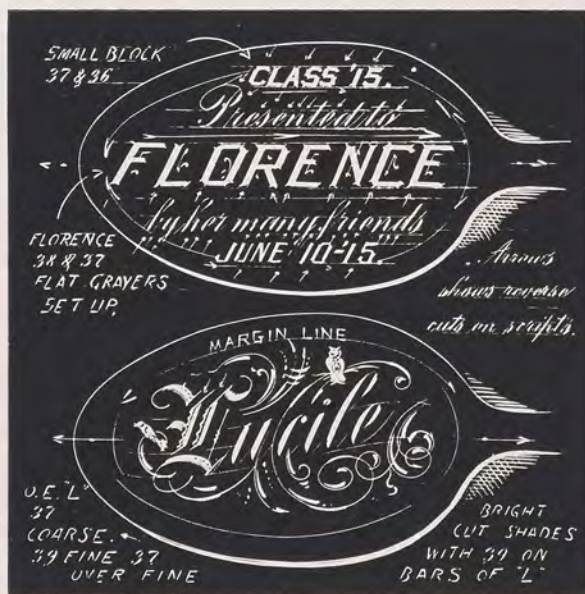
Follow the system shown in this book as applying to methods of designing monograms. The same system of engraving holds, also. First, the skeleton sketch; next, the placing of leaves and hairline outlining; the filling in of the leaves; the close lining of the bars; the bright cutting. Each step comprehensively and simply illustrated by the chart. White and heavy black lines indicate the bright cutting, as shown on charts, Figs. 1, 2, 3, 4, 5 and 6. Pages 23 and 24.

NAMES AND INSCRIPTION WORK OF SPOON BOWLS

Plain, Fancy Script, Block, and Old English Lettering



Display Plate No. 1



Display Plate No. 2

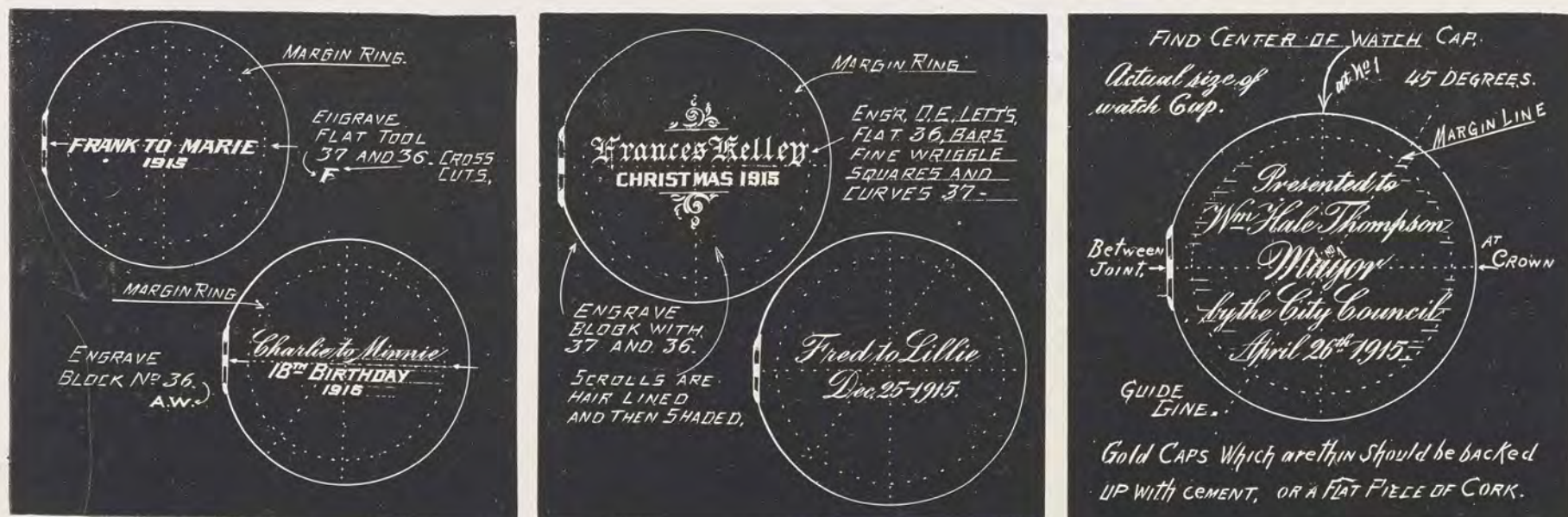


Display Plate No. 3

ENGRAVING SPOON BOWLS

First find the center, pointing the tip of the bowl, then at the handle. Draw the lines with our Patent Spoon Bowl Guide Line Placer, as shown in chart. Then placing the design in capital letters or names, in Script, Block or O. E. as desired. Second, the capital or large letters should be first drawn two-thirds and the small letters one third. Use heeled gravers for cutting. Use No. 39 flat graver for the shading and a round graver, No. 55, for the hairlining. Block letters are also engraved this way by heeling up gravers for any width of cutting desired.

INSCRIPTIONS IN SCRIPT BLOCK AND OLD ENGLISH LETTERING



ENGRAVING INSCRIPTIONS ON WATCH CAPS, ETC.

Before removing the inside cap, cut a small dot with the graver at the crown. Next, using a pin push and small hammer to drive out the pin, from right to left, as shown in chart, a few raps, but do not rivet it. When putting pin back is also shown. Now remove the cap and whiten with Chinese white. Draw a line to the joint, marking a point between the small open part at the joint, as shown in the chart. Draw a circle, leaving a margin of about $\frac{1}{4}$ inch around. Draw a line up and down. Place the intended design. The design is now ready for engraving. If the cap is thin it should be backed up with cement, or a thin piece of cork to prevent denting it and to afford a firm working surface for the graver. It is well to test out a thin case with a rubber marker to determine how much pressure it will stand. The center of a cap is best determined with a divider. To clean a cap after the engraving has been done, boil it out in a cup of ammonia over the flame of an alcohol lamp or over a gas flame. Any small article that is thin should always be backed up with cement or cork. Note for Demonstration, see page 72.

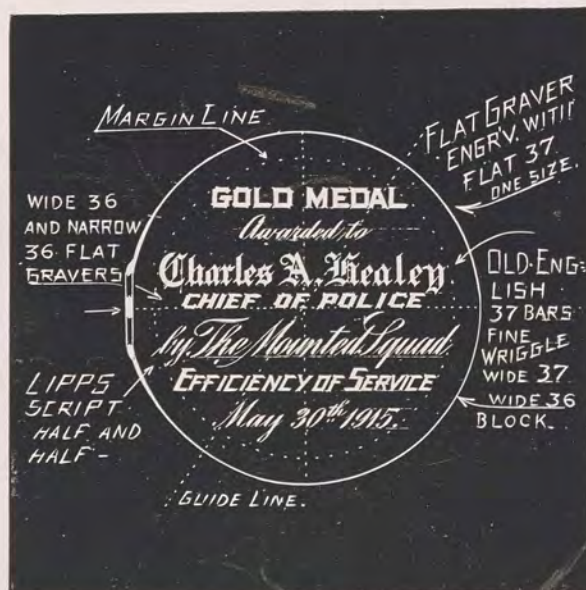
ENGRAVING GOLD-FILLED WATCH CAPS

Be careful not to cut through to the brass. Engrave very lightly.

The best graver for cutting block letters on watch caps is No. 37 when all are cut the same size, using a No. 36 for the cross cuts, as shown in chart. Larger letters in similar ways.

ENGRAVING OLD ENGLISH LETTERS

Cut the bars in bright or dull effect with a No. 36 or 37 graver. Fine wriggle the



squares with dull effect and curves with a No. 37 or 38, always according to size. See chart. Larger letters should be engraved similarly as the charts show, for example:

- Charles A. Healey (O. E.)
- Chief of Police (Block)
- by The Mounted Squad (Script)
- Albert A. Winter (O. E.)
- 25th Anniversary (In block)
- Heyworth Bldg. (In script)

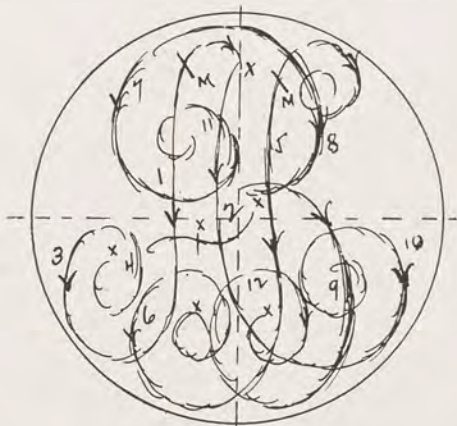
ENGRAVING OF SCRIPT, SOFT WHITE METAL

For BRIGHT CUTTING on soft white metal goods, the graver must be well polished and kept constantly moistened during the cutting. For moistening graver use small sponge, glass of water, or on tongue. As soon as the cut shows a dull, flat effect, the graver must be repolished and then moistened again, as before.

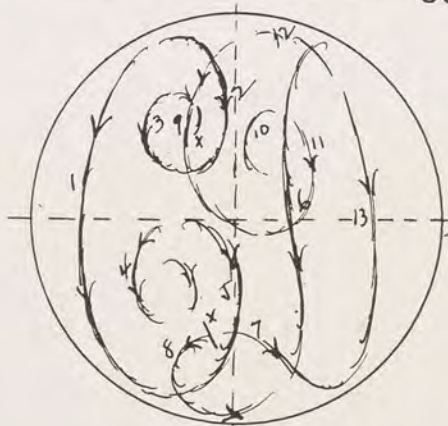
DESIGNING OF SCRIPT MONOGRAMS

Code, for ENGRAVING; THE LINE ^M is to meet THE CUTS, when OUTLINING. THE LINE WITH the X IS TO START BOTH WAYS

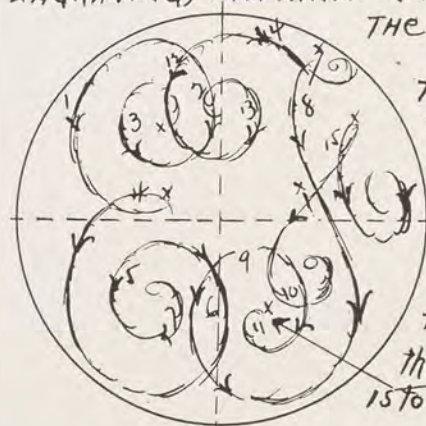
The X AT THE POINTS OF THE SCROLLS IS TO START FROM.



A.B.



C.D.

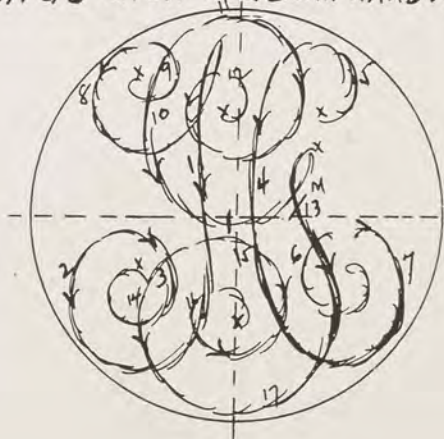


E.F.

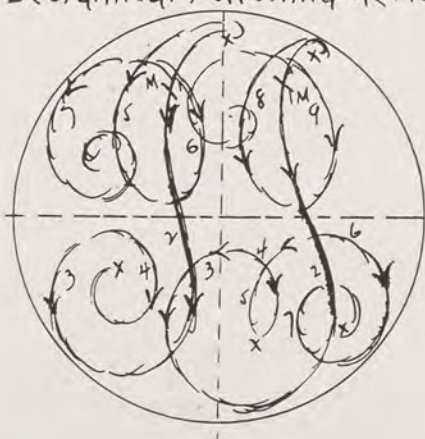
THE ALPHABET IN TWO LETTER COMBINATIONS.

Code, The ARROWS ON THE LETTERS SHOW THE DOWNWARD MOTION IN DESIGNING. Following the NUMBERS AS SHOWN - FOR EXAMPLE "A.B." 1 left 2 right, 3 left & 4. NEXT THE letter "B." 5 TO RIGHT 6 to left, 7 left. ETC. Other letters THE SAME.

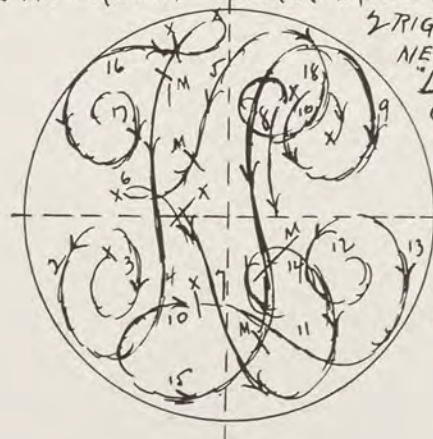
The letter "D" IS CUT DOWN. TO LINE M.



G.H.

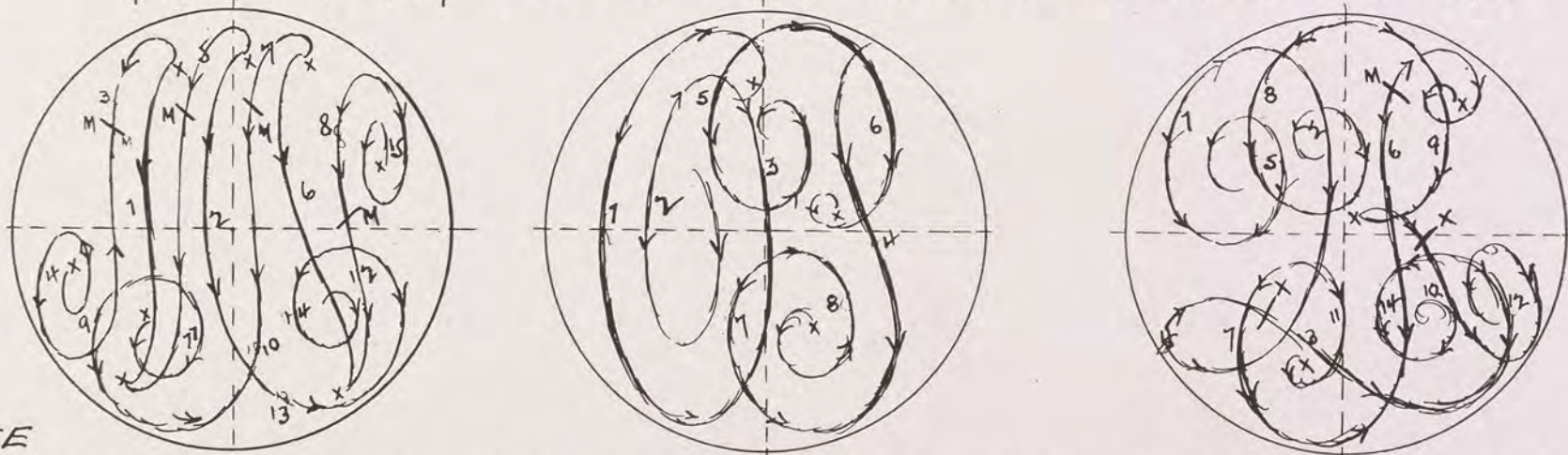


I.J.



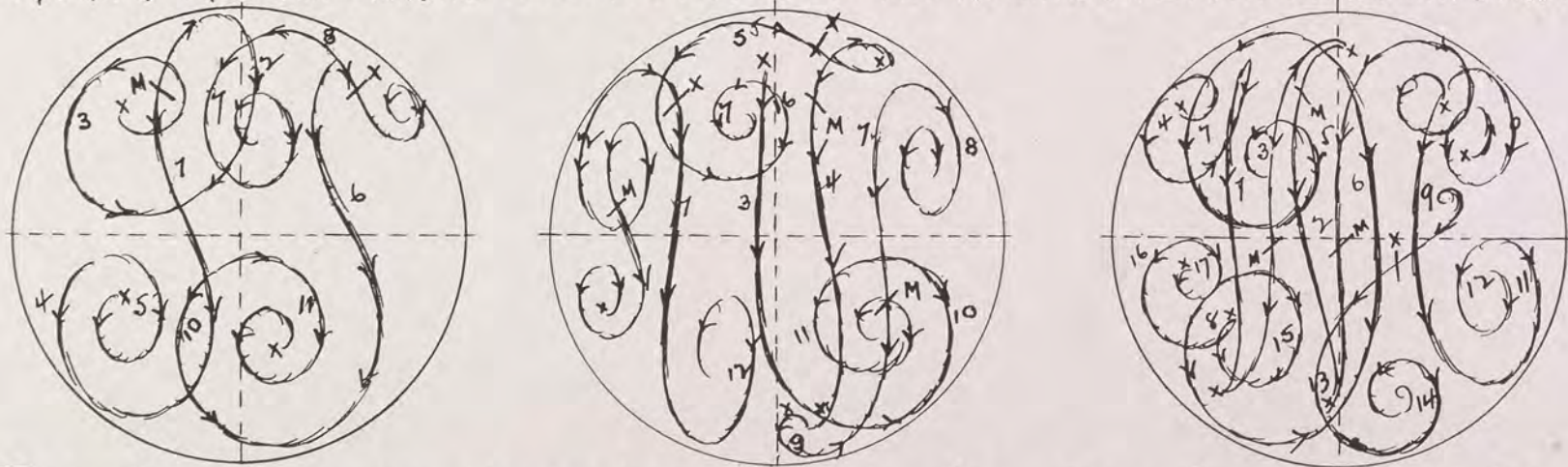
K.L.

DESIGNING LIGHTLY FOLLOWING NUMBERS AS SHOWN ON THE LETTERS, 1-2-3- ETC.



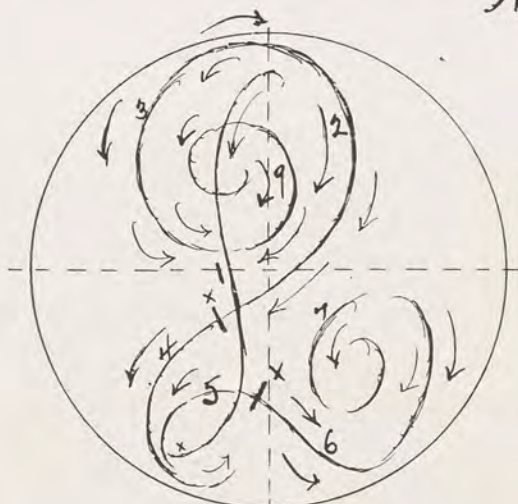
NOTE

DEMONSTRATION- THE ARROWS ON THE LINES SHOW THE MOTION FOR DESIGNING, THE SMALL X IS TO START CUTTING FROM, THE "M" ON THE LINE IS TO MEET THE CUTS. THE X ON THE LINE IS TO START BOTH WAYS-

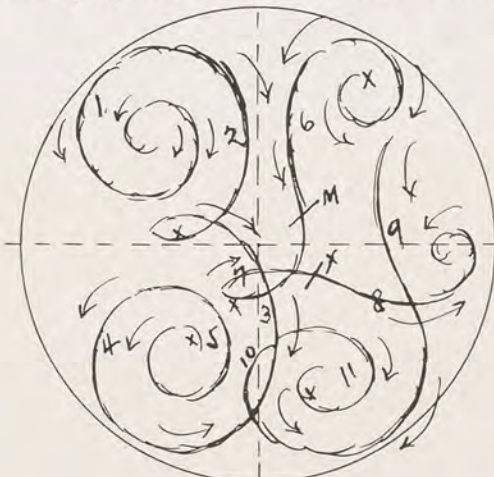


THESE MONOGRAMS ARE ALL OUTLINED FIRST AND THEN CLOSE LINED IN DULL EFFECT.

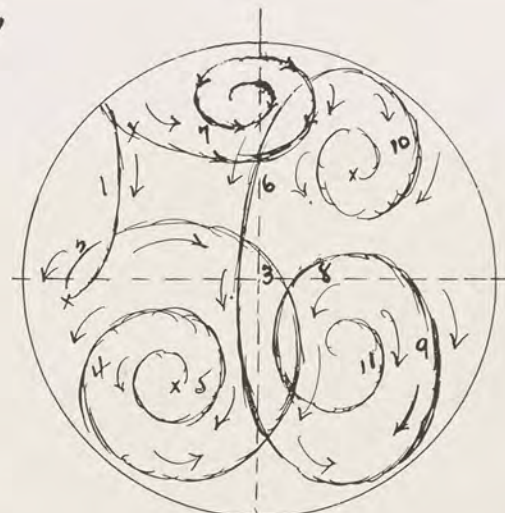
MONOGRAMS IN FIGURES.



12

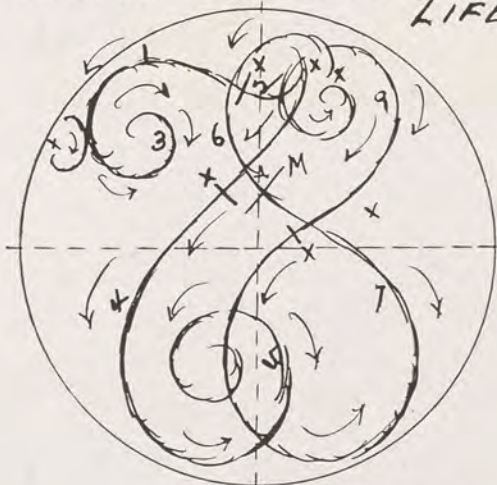


34

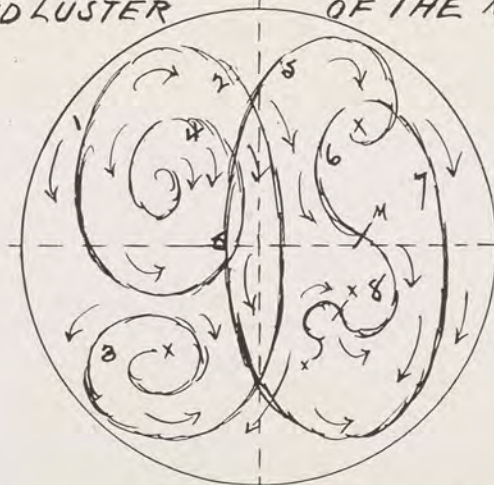


56

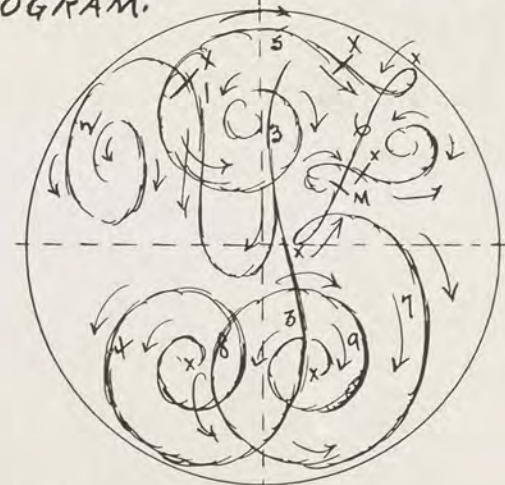
Then BRIGHT CUTTING THE SHADES AT THE EDGES TO BRING OUT THE BEAUTY OF THE MONOGRAM.
LIFE, AND LUSTER



78



90



x.z.

IF YOU DONT UNDERSTAND ASK US, HOW.

PLAIN CLOSELINE STEMS FOR CLOSELINE MONOGRAMS



Plate No. 1



Plate No. 2



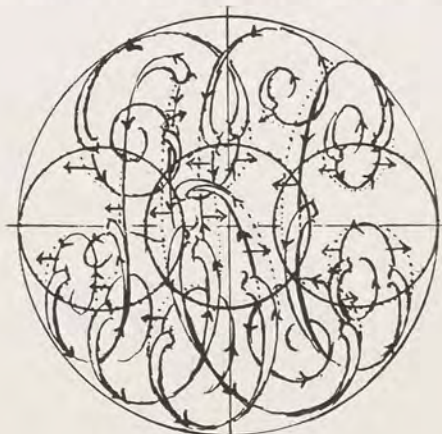
Plate No. 3

PRACTICE LESSONS

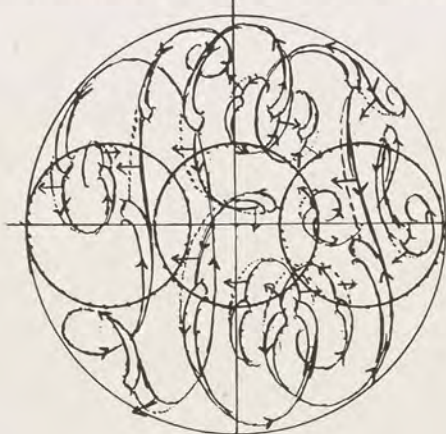
The following stems should be practiced from two to three hours daily for a week, until mastered, before you should attempt to start engraving complete monograms. Practice these stems alone, first taking them in rotation by Nos. 1, 2, 3, 4, 5, 6, 7, 8, 9, 10 and 11; for example, start with No. 1, next Nos. 2 and 3, finally 4, and go back to Nos. 1 and 2; next take Nos. 5, 6, 10 and 11, and 8, 9, and back to 3 and 4. Keep changing off so as not to get tired of them, and do not practice too long at one stem. This will bring better results.

Plate 2 shows monograms completed. When engraving monograms, always be sure and cut all the main stems first, and then the loops or scrolls should follow, always observing signs and arrows which will guide you.

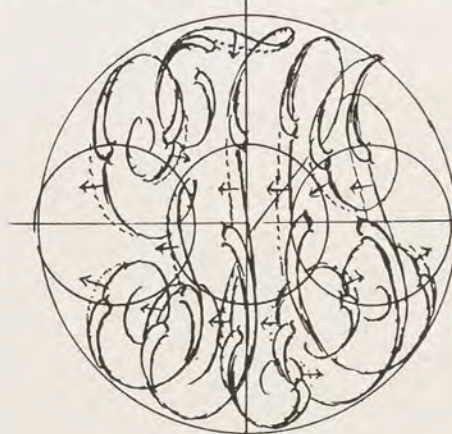
THE ALPHABET IN THREE LETTER COMBINATIONS.



A.B.C.

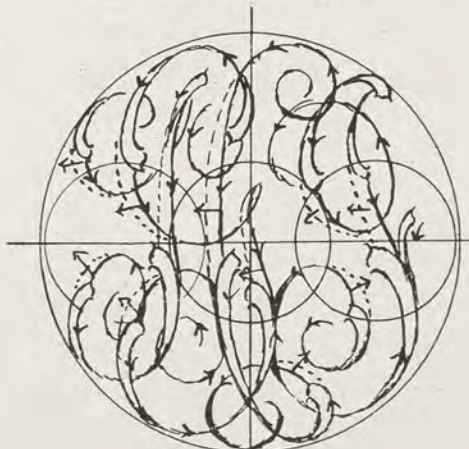


D.E.F.

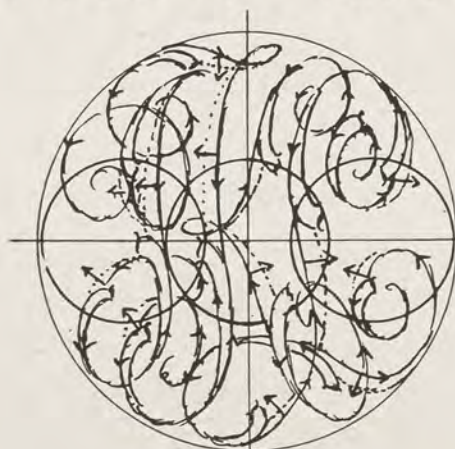


G.H.I.

SHOWING THE METHOD OF PLACING THE LEAVES.



G.H.I.

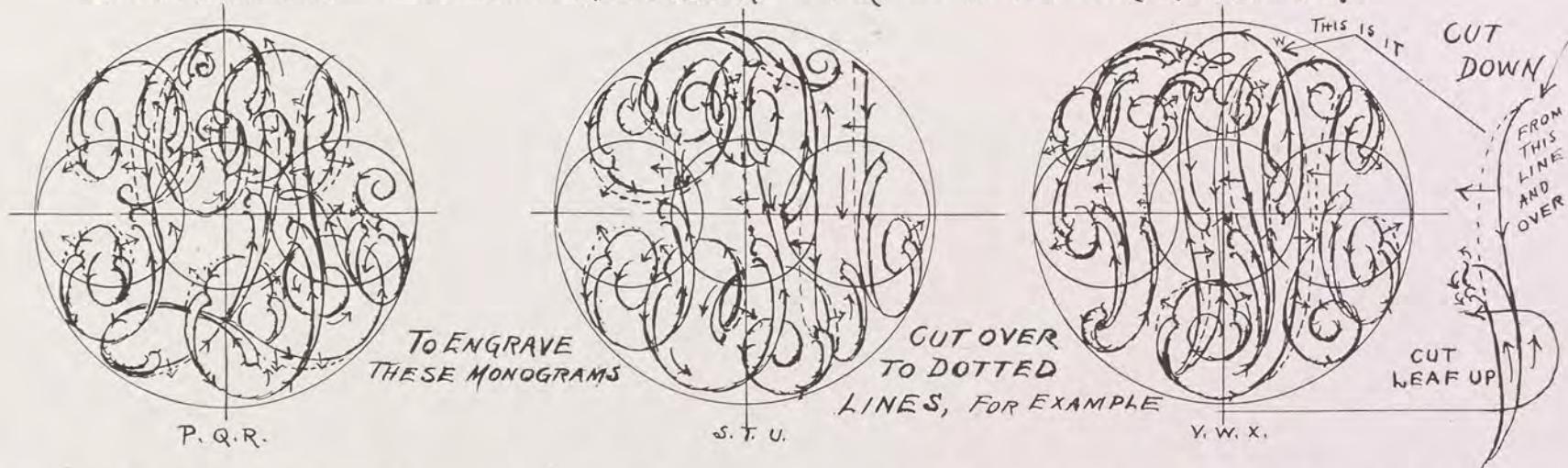


J.K.L.

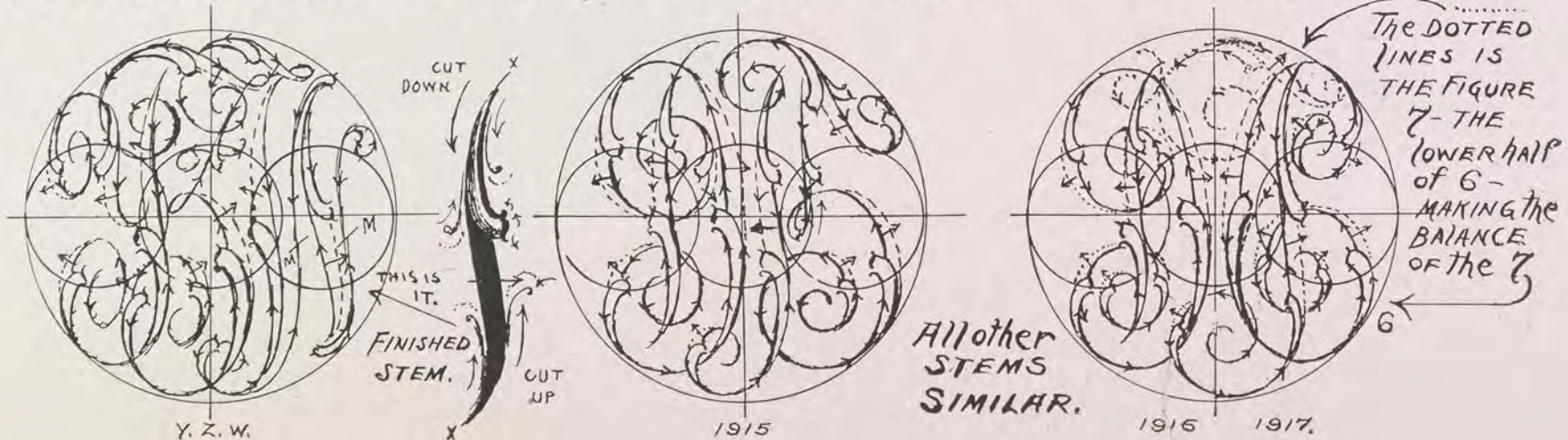


M.N.O.

METHOD USED IN DESIGNING AND ENGRAVING.



THE ARROWS SHOWING THE WAY TO ENGRAVE THE LETTERS.



CLOSELINE LEAF STEMS

For Closeline Leaf Monograms



Plate No. 1

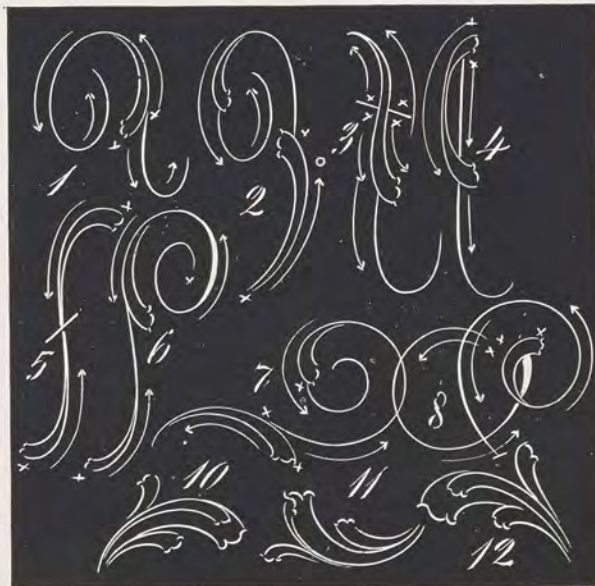


Plate No. 2

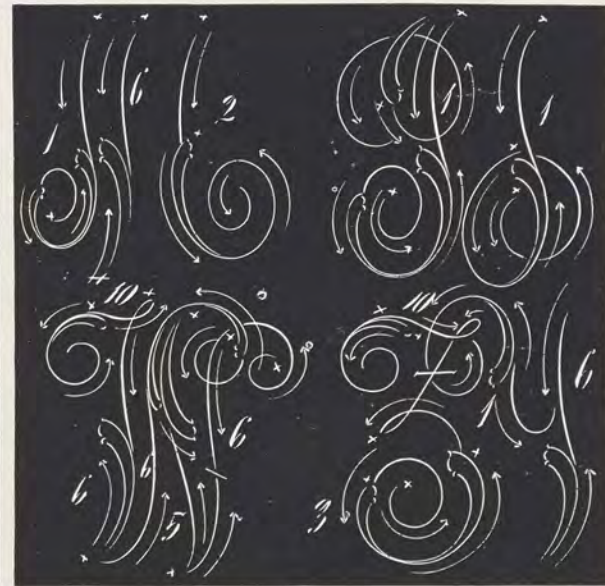


Plate No. 3

Practical demonstrations of these stems. First Practice Lessons.

1. The design. 2. The outlining, commencing with the leaves from tip to tip, always cutting the way arrows point. 3. The close-lining is done next. 4. The filling of the leaves, finally the bright cutting at the edges. Display Plate 3 shows the letters I and J, stems 1, 1. Stem Nos. 6, 6, 5 and 10, making the W. Stem Nos. 10 and 3, 1 and 6, making the Y. Monogram Z Y. Nos. 10, 11 and 12, showing the leaves outlined for filling, which have to be practiced individually until mastered (for a few weeks at least). These leaves are more complicated in nature, which requires more study—for grace, beauty and form—with the proper shading effects.

MONOGRAM STEMS FOR CLOSELINE LEAF MONOGRAMS

Demonstration Below

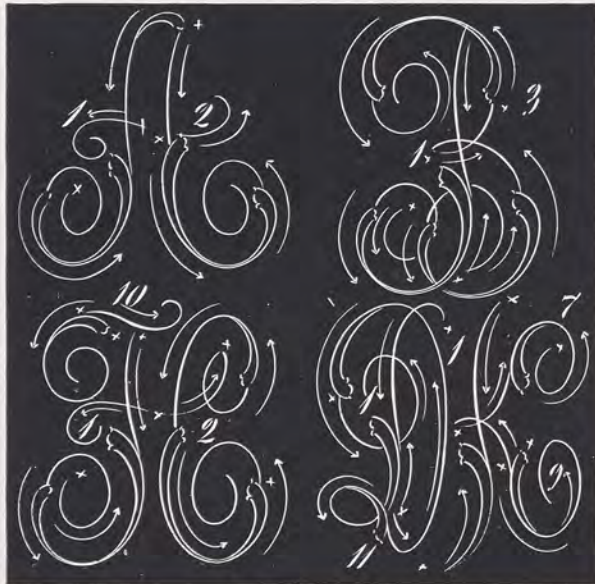


Plate No. 1

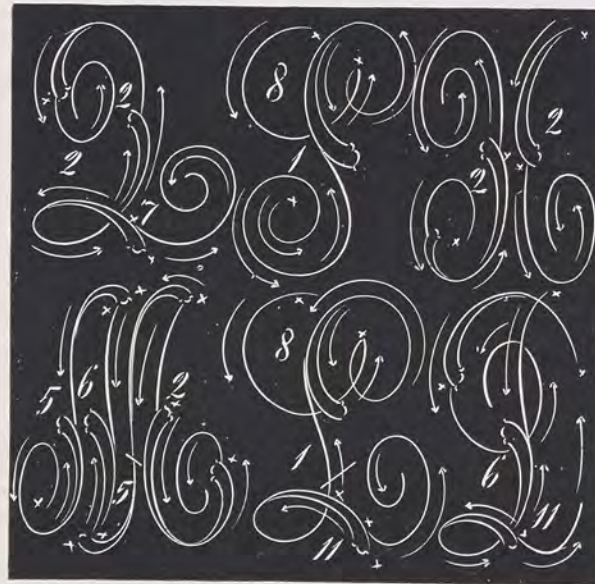


Plate No. 2



Plate No. 3

How to Make and Build Monograms

Lesson. Display Plate 1.—Stem Nos. 1 and 2, making the A. Stem Nos. 1 and 3, making the B. Stem Nos. 1, 2 and 10, making the H. Stem Nos. 1 and 1, 7, 11, 9, making D. K. Display Plate 2.—Stem Nos. 2, 2 and 7, making Q. Stem Nos. 8 and 1, making the S. Stem Nos. 2, 2, making X. Stem Nos. 6, 2 and 5, 5, making M. Stem Nos. 8, 1 and 11, making L. Stem Nos. 6 and 11, making D. Monogram Display Plate 3.—Stem Nos. 1, 9, 3, making the R. Stem Nos. 6, 10, 1, making the V, which reads Monogram R V. Stem 1, loop 3, with loop 4, making Monogram E P. Stems 1, 5, 1, with 6, 11, making Monogram N L. Stems 4, 8, with loops 2 and 2, making Monogram G O. The small white crossline is to meet the cutting. Small X on the line is to cut both ways. The small X indicates where to start from, following arrows.



Plate No. 1

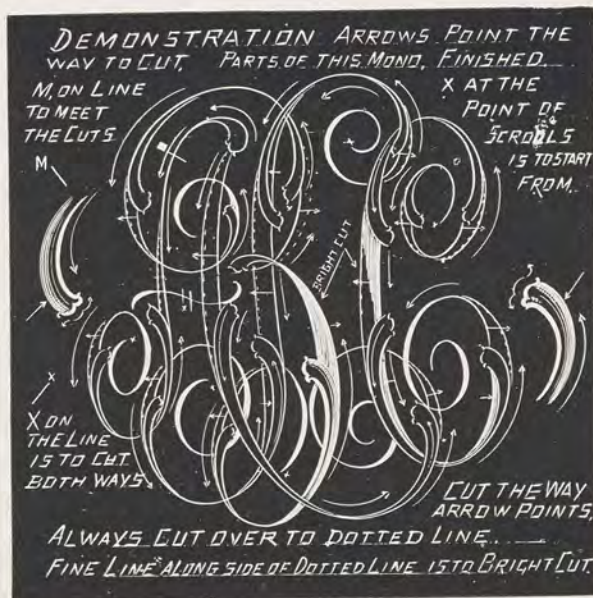


Plate No. 2



Plate No. 3

CLOSELINE LEAF MONOGRAMS

Plate 2 shows demonstration for any close-line leaf monogram. Plate 4 shows some running, linked script, A, M, A, and below H, B, L in vertical style; on the sides of plate, a few drop monograms. These letters may be bright cut, like script or closelined, according to size.



Plate No. 4

Plate 3 shows monograms. 1, designed and outlined; 2, shows next step, close-lining; 3, shows filling in of the leaves; 4, shows the monogram, W R, complete, with bright cutting; all other monograms must be cut similarly.

Al. A. Winter,
Instructor.

DISPLAY PLATE

LIEUTENANT COM-
MANDER

Fine Light Script
For inscription work.

PLAIN CLOSELINE
CIPHER I. K. R.

For signet rings, lock-
ets and watch cases.

MARION CRAWFORD

Plain, solid cut, Old
English letters with very
little fancy work.

DETROIT

In Roman Type, Fancy
Scrolls

Engraved with square
graver, finely closelined,
for inscription work,
watch caps, etc.



RICHMOND PEARSON
HOBSON

Plain Cut Script

THE HERO OF THE
MERRIMAC

Little Fancy Script

MONOGRAM A G
OR G A

Combination Ribbon
Cipher

Closelined, for lockets
and watch cases.

MONOGRAM IN CENTER—E. P. S.

Demonstration of Engraving

Style, Combination Ribbon, Rose Leaf and Dragon Head

1. The design of the letters. 2. The outlining of the letters and leaves, dragon head and rose. 3. Ribbon filling of the letters E. P. S. 4. Shading of the leaves. 5. Shading of rose and dragon heads, and flowers. 6. Engraving of the dragon's neck, shading the balls. 7. Bright cutting of all the leaves, rose, flower and ornaments, which is now finished.

Note.—The lower half of the letter S is closelined, showing black.

WINTER SCHOOL OF
ENGRAVING

Combination Script and
Roman Block Style

which is cut in bright cut
shades, cutting the shades
up and down against each
other, giving a beveled
edge appearance.

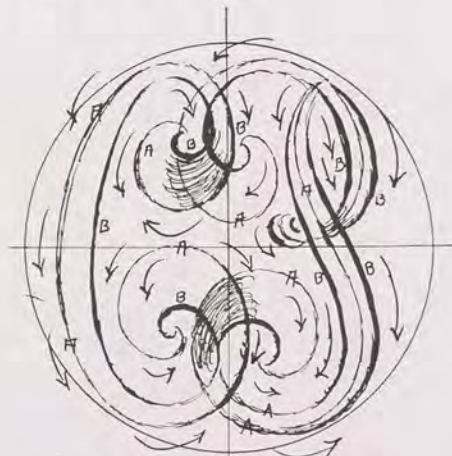


DROP MONOGRAMS

Draw three circles, one overlapping the other, as shown in chart by dotted lines. Next draw line up and down for center of circles.

Drop monograms and monograms with one letter below the other are designated as Drop Monograms. They may be engraved in any style, as other monograms, and the designing and engraving is done after the same manner as shown in chart. They are especially appropriate for spoon handles and similar long, narrow articles. They are appropriate, too, on larger square articles, like cigarette cases, oval lockets, match safes, etc. Small sized drop monograms should be bright cut, large, closelined. Ribbon and ribbon leaf drops are engraved the same way.

METHOD USED IN DESIGNING DOUBLE LINE CIPHERS.

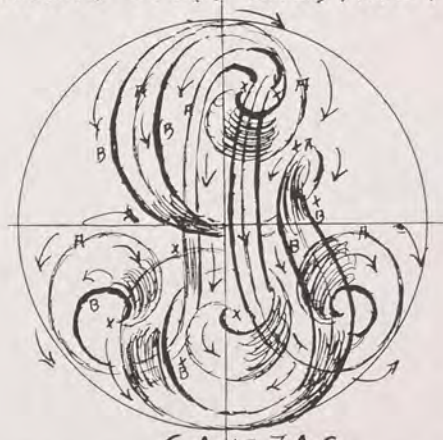
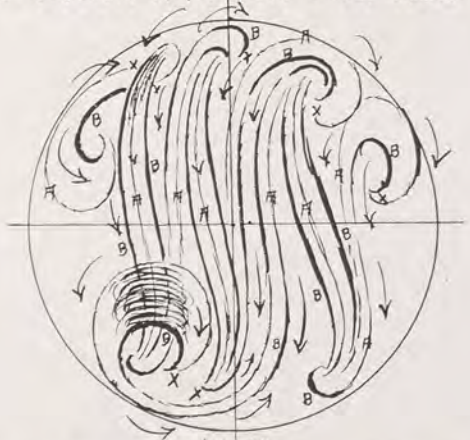


NOTE DEMONSTRATION. - A. B.

R. A.

C. P.

THESE MONOGRAMS ARE ALL DRAWN IN THE FINE LIGHT, ROUGH SKELETON SKETCH. MARKED A NEXT THE BLACK LINES MARKED B. ARE DRAWN ON EACH SIDE AS SHOWN. 3rd THE FINE BLACK LINES SHOWN ARE FOR THE LOOPS CROSSING OVER ONE, AND THE OTHER. AND NOW READY TO ENGRAVE.



W. N.

G. A. OR A. G.

J. K.

THE ARROWS SHOW THE MOTION FOR DESIGNING. THE SMALL X IS TO START TO CUT FROM.

METHOD OF DESIGNING RIBBON, AND RIBBON LEAF MONOGRAMS. PLAIN AND FANCY

FIG 1
SINGLE HAIR
LINE, FOR
DRAWING
THE
LETTERS.

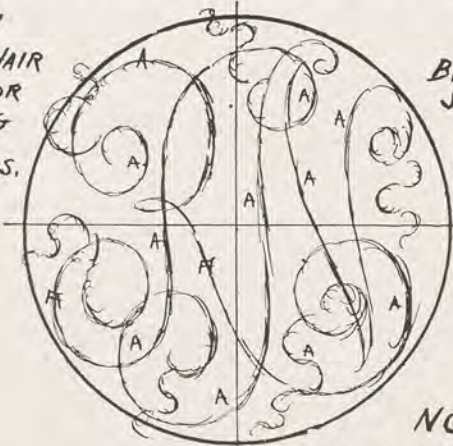
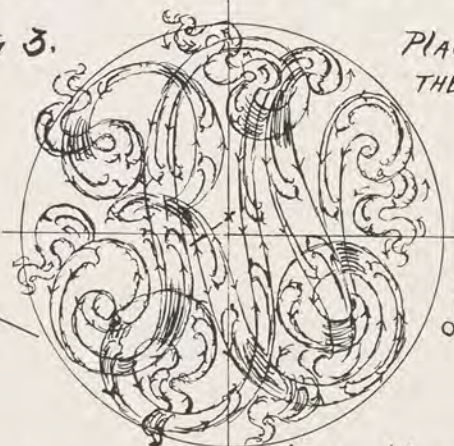


FIG 2
BLACK LINES
SHAPING
INTO
RIBBON



FIG 3.



PLACING
THE LEAVES.

R.N
SHOWS
FINE
LINES
OMITTED.

NOTE

DEMONSTRATION FOR ENGRAVING THESE MONOGRAMS.
THE SMALL 'X' IS TO CUT FROM-BOTH WAYS - ('X ON THE LINE IS THE SAME
SMALL LITTLE ARROWS INDICATE THE WAY TO CUT.

NOTE

THE FINE LINES BETWEEN
THE BLACK, MARKED B
ARE NOT ENGRAVED.
FIG 6.

FIGS 4-5-6
ARE READY
FOR
ENGRAVING

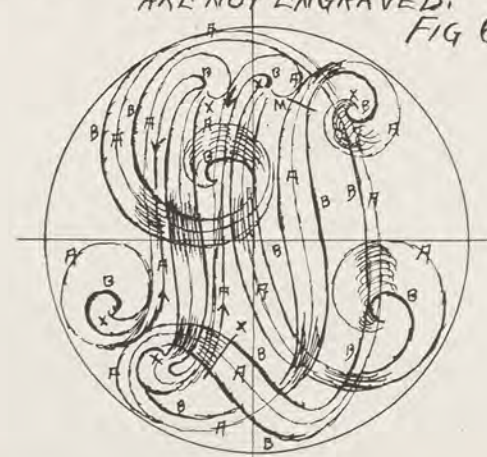


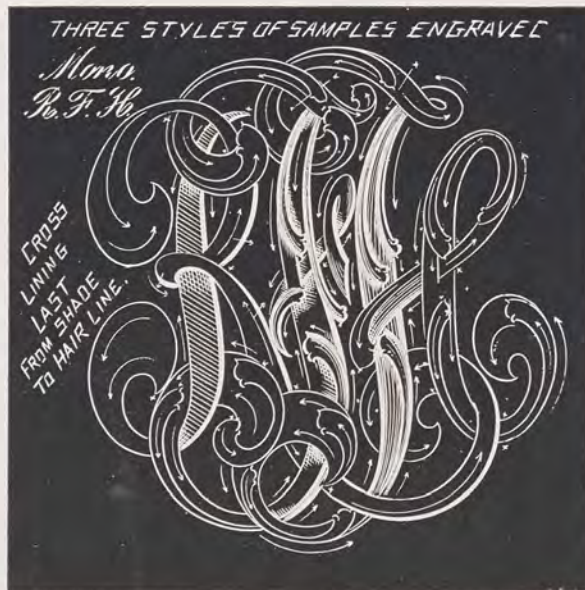
FIG 4.

FIG. 5.



"M" ON THE LINE IS TO MEET THE CUTS
THE FINE BLACK LINES, ARE WHERE THE LETTERS GO OVER AND UNDER.





DESIGNING OF DOUBLE LINE CIPHER AND RIBBON MONOGRAMS

Having drawn the single lines, marked A, as above described, draw a line to each side of it, marked B, making three lines in all. See chart, herewith. On upper curves, draw a line above, marked B, the single line already drawn, marked A, which makes two lines in all. On the lower curves, marked A, draw a line below the single line, marked B, already drawn, making two lines in all. Take the ends of these, connect them and your ribbon monogram is ready for engraving.

The same method is used for ribbon leaf, the leaves being placed last, as shown in chart.

Having prepared the design as above, the work of engraving may proceed. 1. Outlining the design, cutting a fine line. 2. The filling in, which is open lined, gradually opening the cuts and closing the cuts, as shown in chart. The same method is used in ribbon leaf work, the leaves to be engraved last. 3. Finally the shading, bright cutting, is done, and this completes the monogram.

DISPLAY PLATE

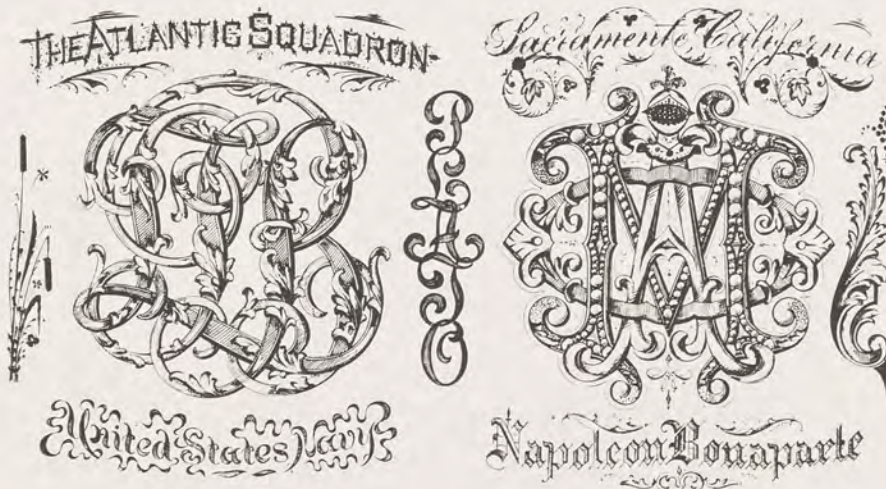
BLOCK STYLE

Atlantic Squadron

Engraved in all sizes. Flat tools: Nos. 36, 37, 38, fine lines in the fancy work around the letter, done with a square graver.

Closeline Leaf Cipher

1, Design; 2, outline of the letters and leaves; 3, shading, which are the black lines; 4, cross lining right and left; 5, filling in of the leaves; 6, bright cutting the leaves.



UNITED STATES NAVY

Closeline Ribbon Script

1. Designing of the lettering in the rough, light, skeleton sketch.
2. Outlining of the letters.
3. Close lining of the letters.
4. Bright cutting of the letters at the edges, last lines.

RIBBON
DROP
MONO-
GRAMP. L. A. or
A. T. O.

Hairlined, outline and filling of lines last.

These letters may be engraved in other styles.

FANCY SCRIPT NAME

Sacramento, California

Engraved in plain, bright cut. For larger work, close-line the lettering. The fancy work is done last.

BLOCK MONOGRAM

O. A. M.

1, Design; 2, outline; 3, shading; 4, crosslining of the O, and finishing of ornaments; 5, shading of the A, and ornaments; 6, ball filling of the M, outlining the balls, close lining between the balls which shows the black, giving the balls a raised effect.

NAPOLEON BONAPARTE

Crossline Shaded Old English

1. The designing of the letters.
2. The hairline outlining.
3. The shading at right hand of bars, squares and curves.
4. The filling in of the hairlines, cutting from right to left from the shades.

THE USE OF A RULE, AND DIVIDERS ARE NECESSARY FOR DRAWING FOR DETAIL WORK
VERY LITTLE FREE HAND DRAWING AS THESE MONOGRAMS ARE MORE MECHANICAL IN NATURE

FIG. 1.
USEING THE
DIVIDERS TO
DRAW THE
CIRCLES &
OVALS, TO
CENTER UP
THE LETTERS
HERE
THE TWO
SMALLER
CIRCLES ARE
FOR THE DOTTED
LINES TO BAIIANCE
UP THE LETTERS.

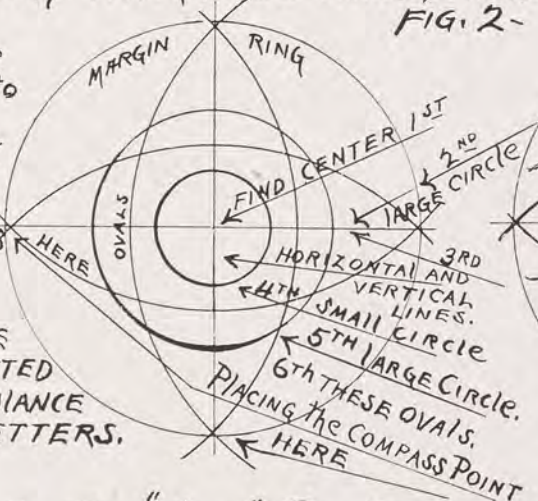
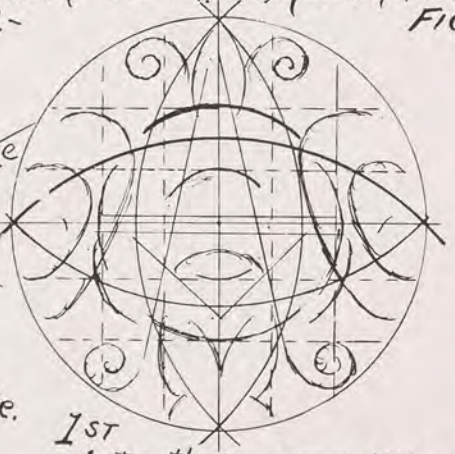
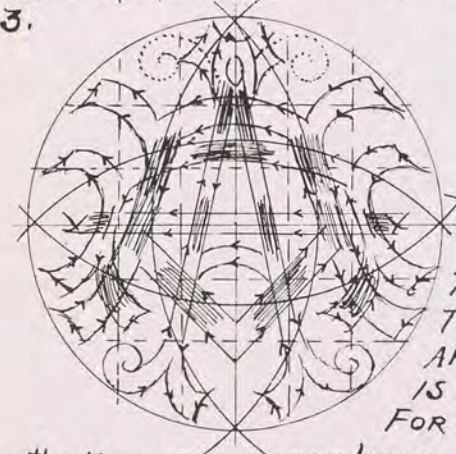


FIG. 2-



1ST
After the DESIGN IS MADE AND THE MONOGRAM IS OUTLINED.

FIG. 3.



2ND
RUBBING OFF
THE WHITE
AND MONOGRAM
IS NOW READY
FOR THE FILLING.

FIGS. 3-4-5- "Now" Ready FOR ENGRAVING, BEING OUTLINED WITH SQUARE GRAVER-
Following THE ARROWS AS SHOWN ON THE LINES OF LETTERS & THE ARROWS WHICH POINT TOWARDS THE LETTERS
ARE FOR PLACING THE SHADES.

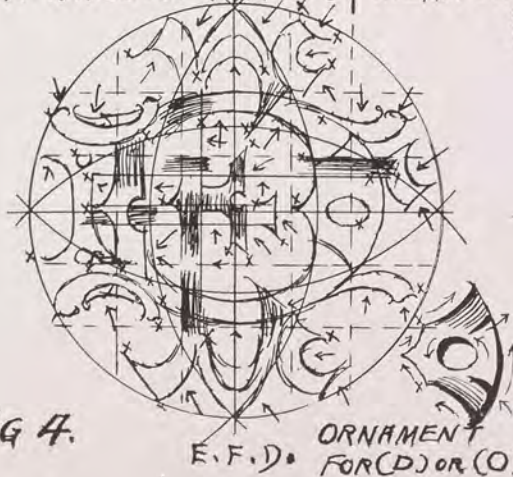
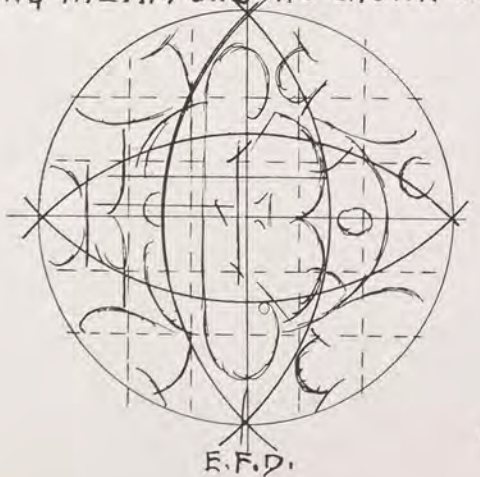


FIG 4.

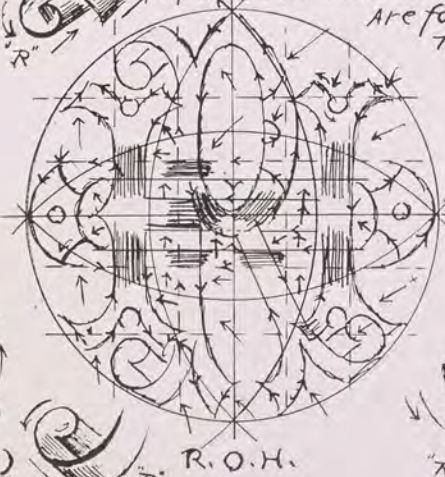
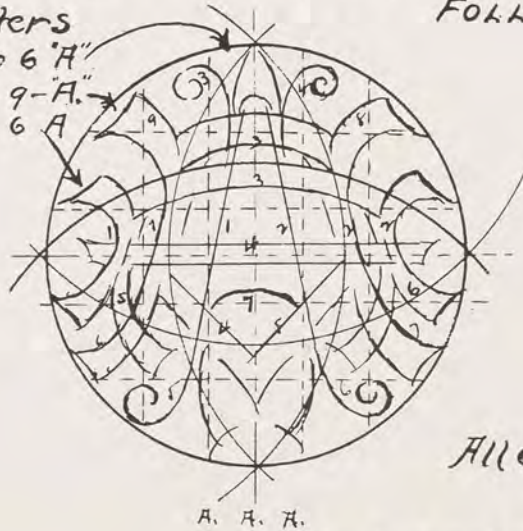


FIG 5.

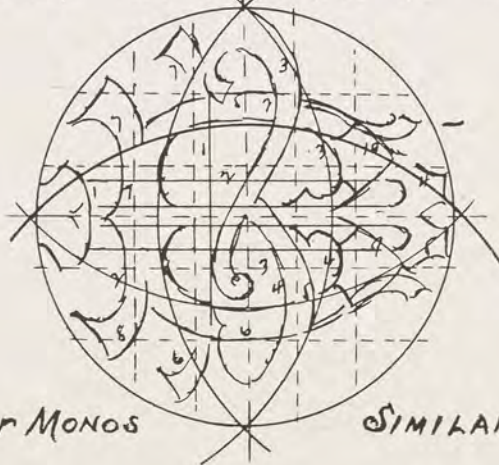
ENGRAVING
OF SAME
ROLLING,
R SCROLLS.

DESIGNING OF THESE MONOGRAMS ARE IN THE ROUGH SKELETON SKETCH.
FOLLOWING THE NUMBERS AS SHOWN.

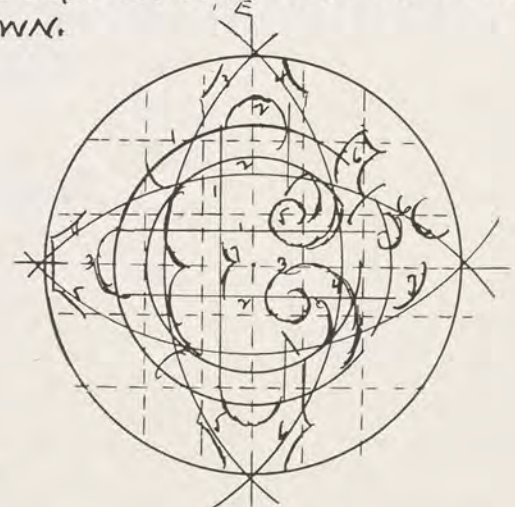
Letters
7 to 6 "A"
7 to 9 "A"
7 to 6 "A"



A. A. A.



B. B. B.

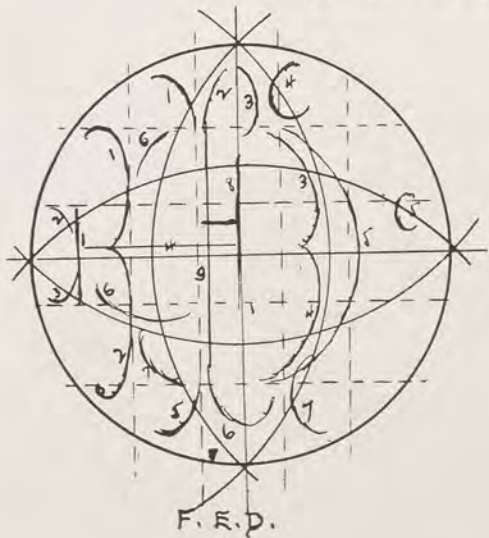


C. C. C.

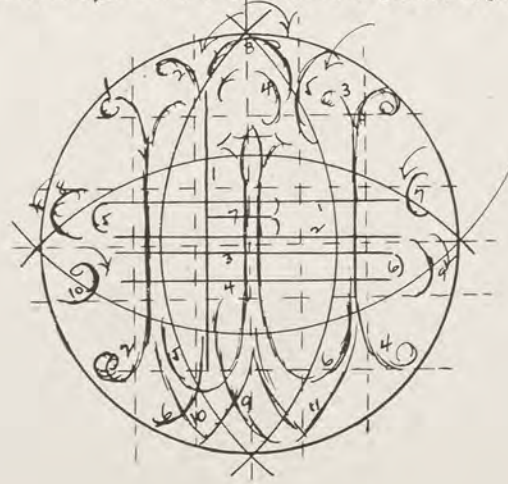
All other MONOS

SIMILAR.

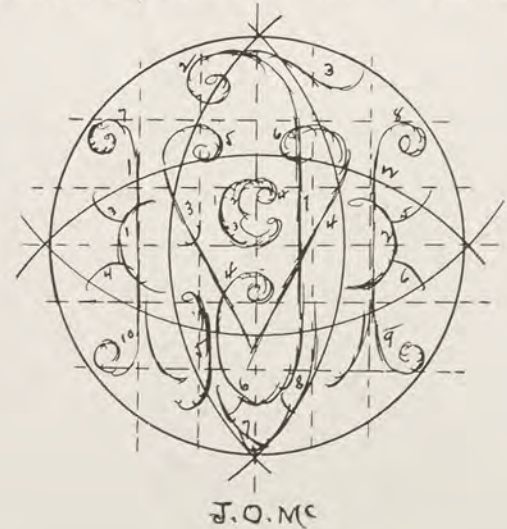
Which are then SHAPED INTO DOUBLE LINE DESIGN, SHOWN ON FOLLOWING PAGES.



F. E. D.

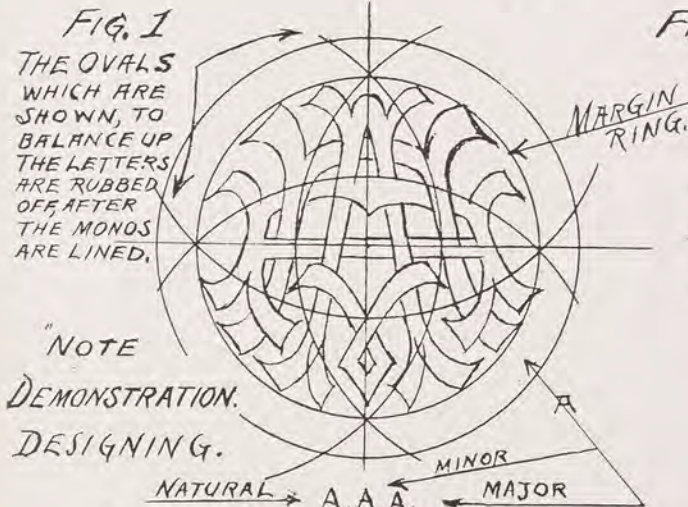


S. F. W.



J. O. M. C.

BLOCK AND ROMAN MONOGRAMS.



NOTE THE LETTERS WHICH GO OVER AND UNDER MUST BE DRAWN SO THEY CAN BE DRAWN APART.

HOW TO READ THE BLOCK AND ROMAN MONOGRAMS, THE LAST LETTER BEING THE MOST PROMINENT.

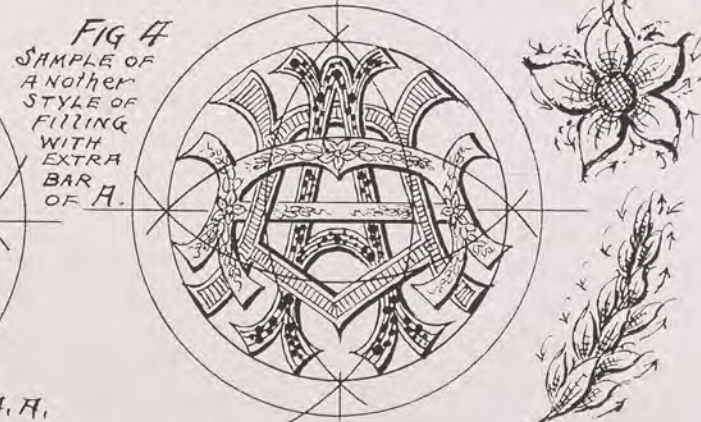
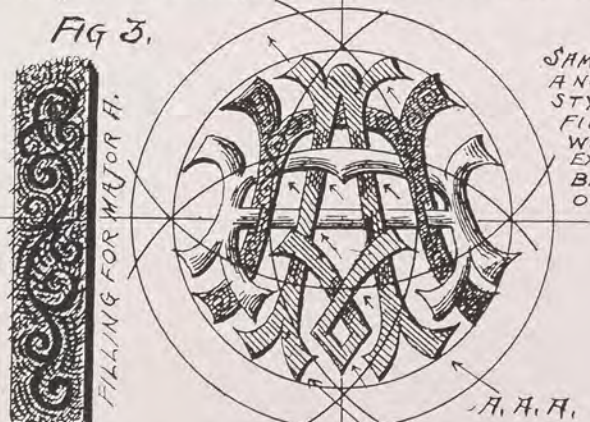
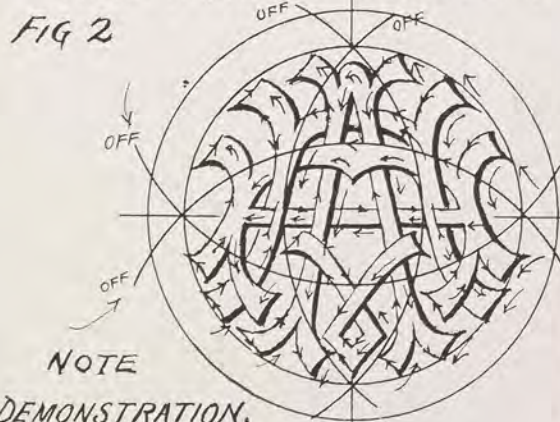


FIG 1 THE DESIGN, AND OUTLINING WITH GRAVER, FIG 2 THE PLACING OF THE SHADES, NEXT, FILLING IN-OF THE LETTERS. BEING CAREFUL TO FOLLOW THE ARROWS AS SHOWN. PLACING THE GRAVER THE PROPER WAY TO CUT.



Monogram A. B. C. Engraved

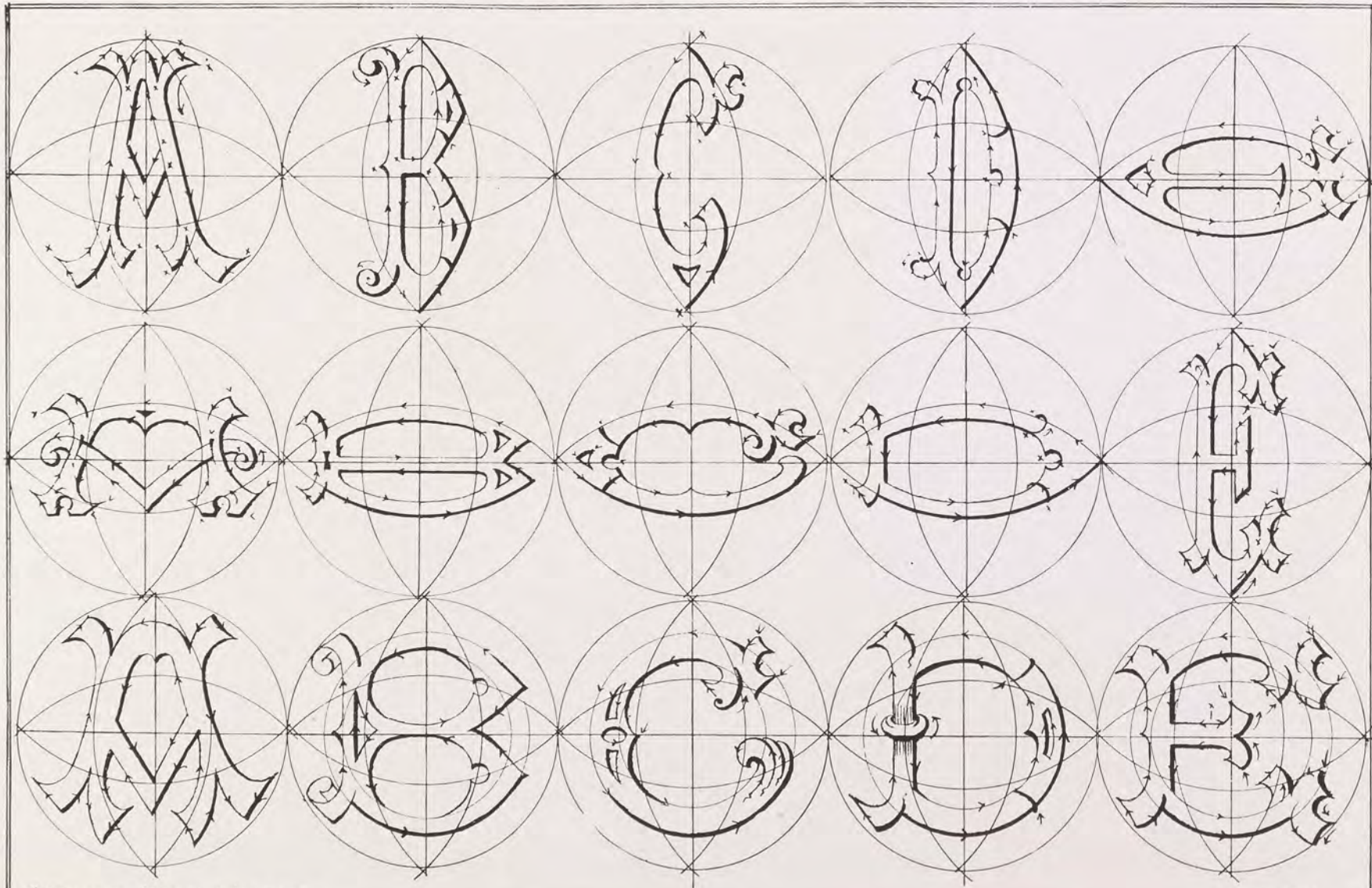
DESIGNING OF BLOCK AND ROMAN MONOGRAMS

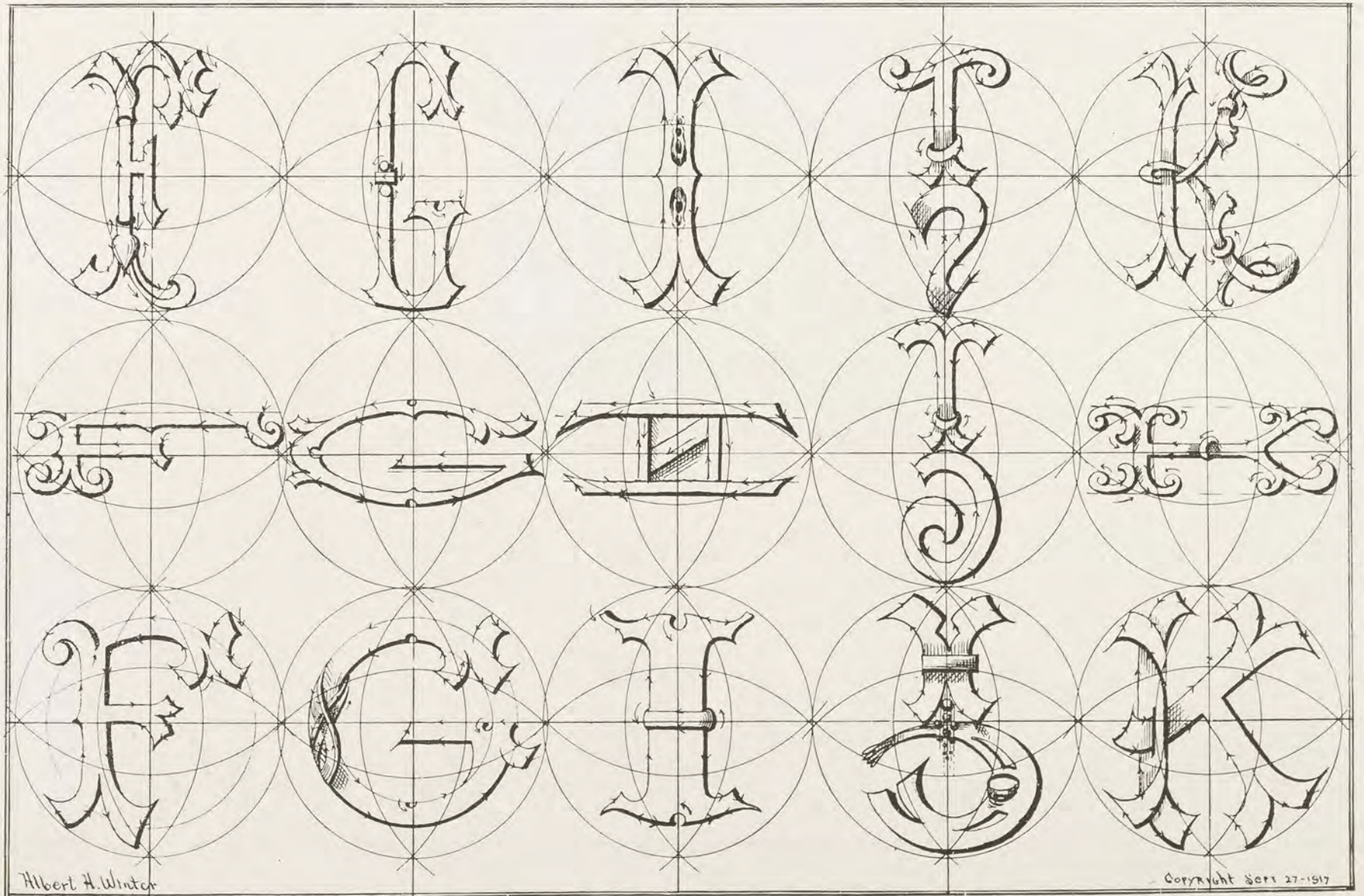
is made easy if the following plan is followed: Draw a circle, then a line up and down and one crosswise through its center. Use the dividers to draw an oval, placing the compass points on the right and left of the circle where the lines meet. Then draw oval, as illustrated by chart. Here begin the designing as shown in Fig. 1, Page 45, and layout and sketch of design. Use the magnesia to touch up the design here and there. Shape the letters in clear, distinct detail. Now proceed with the engraving. As usual an outline of the lettering should first be engraved; the filling in should follow to secure the desired effect, all of which the accompanying chart demonstrates, step by step. Follow arrows closely.

EFFECTS IN ENGRAVING

HOW TO SECURE VARIOUS EFFECTS IN CUTTING in any style of Script, Block, Old English, and in monogramming is shown in the accompanying charts.

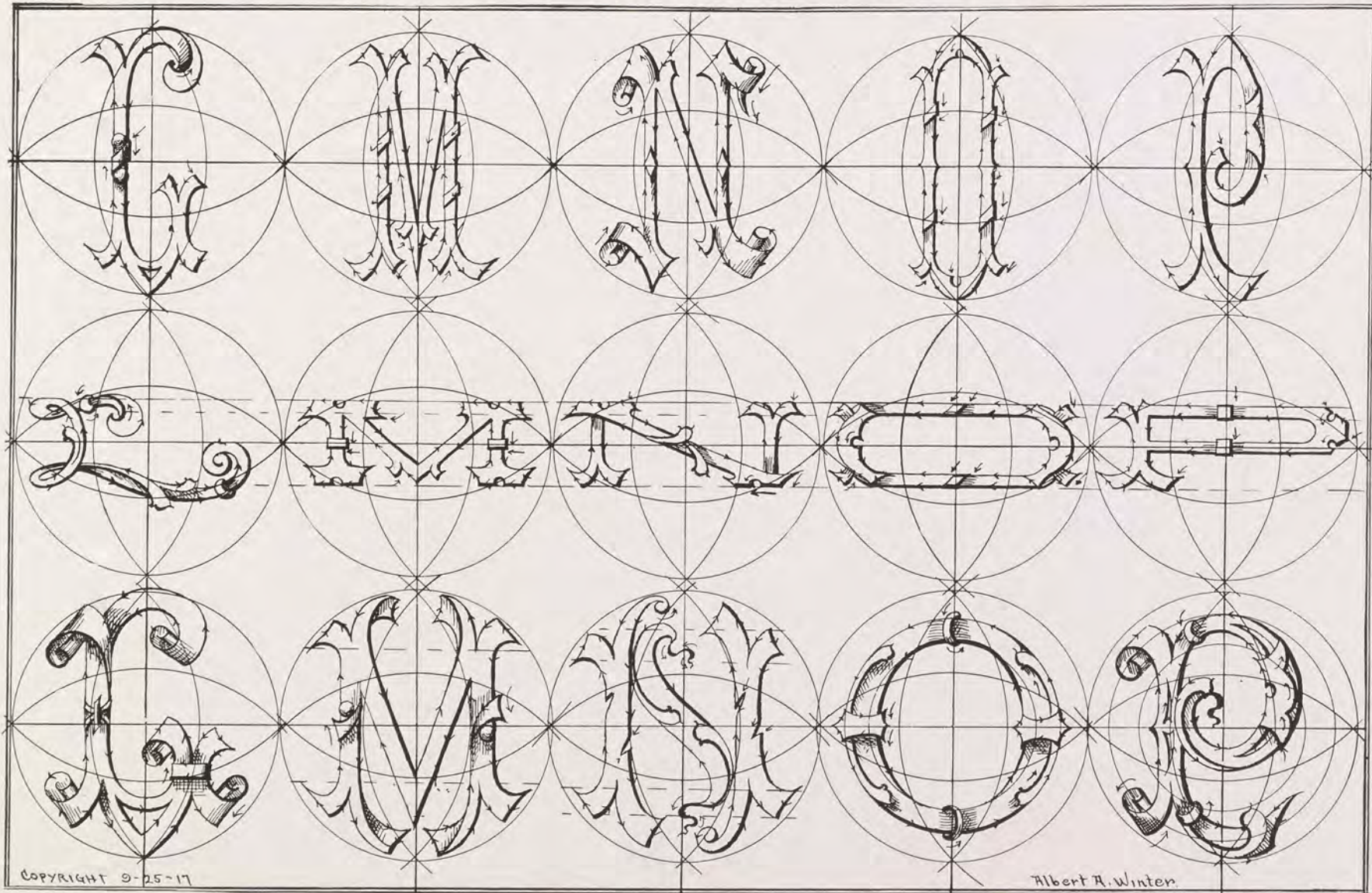
We illustrate several of these styles of cutting, viz: close lining in dull, flat effect with or without a polish; bright cut; crossline shading; ribbon filling; closeline; ball filling, with leaves; wavy ribbons; crossline shades with leaves, closeline ribbon with or without leaves, etc.

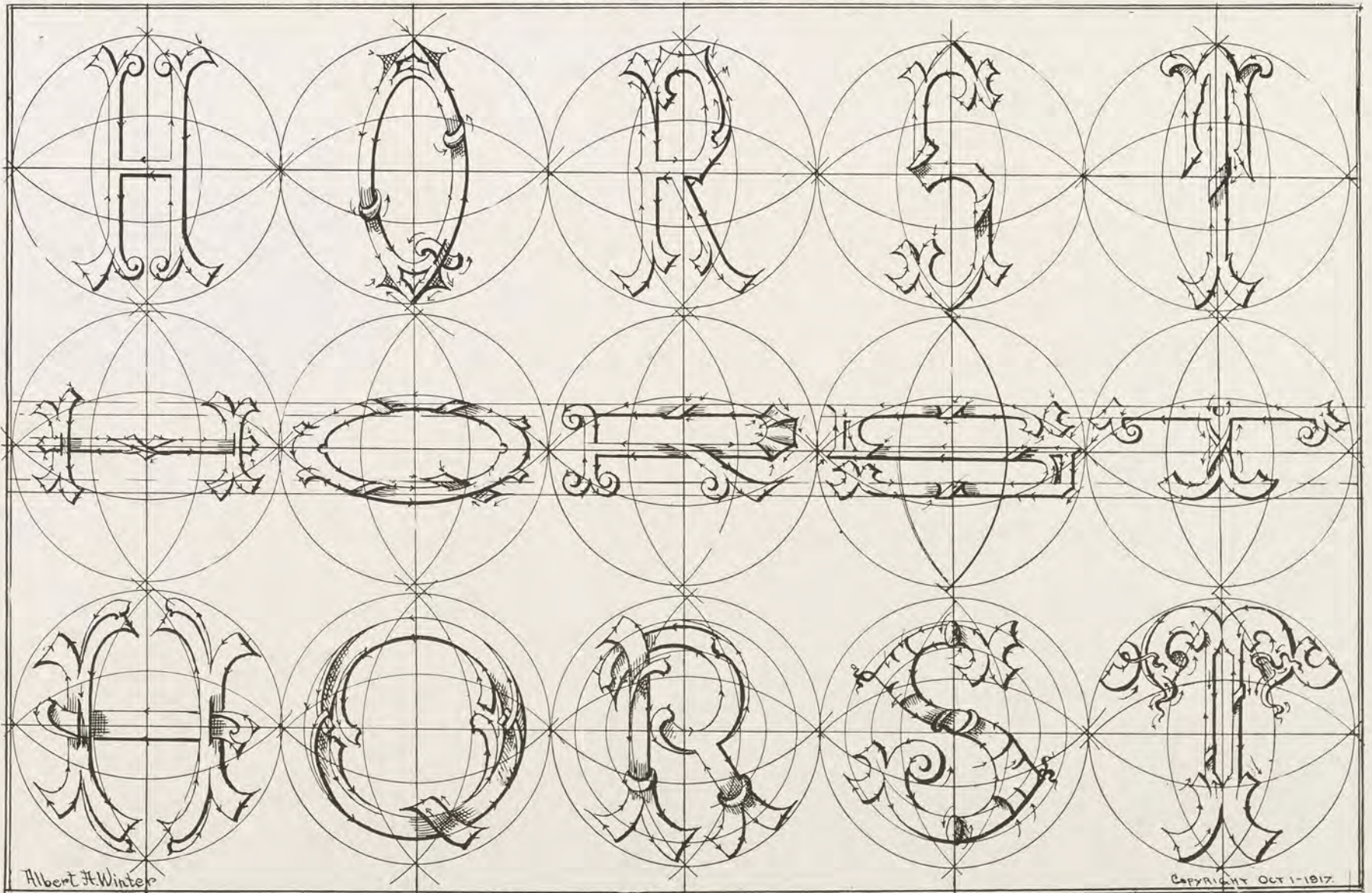




Albert H. Winter

Copyright Ser. 27-1917



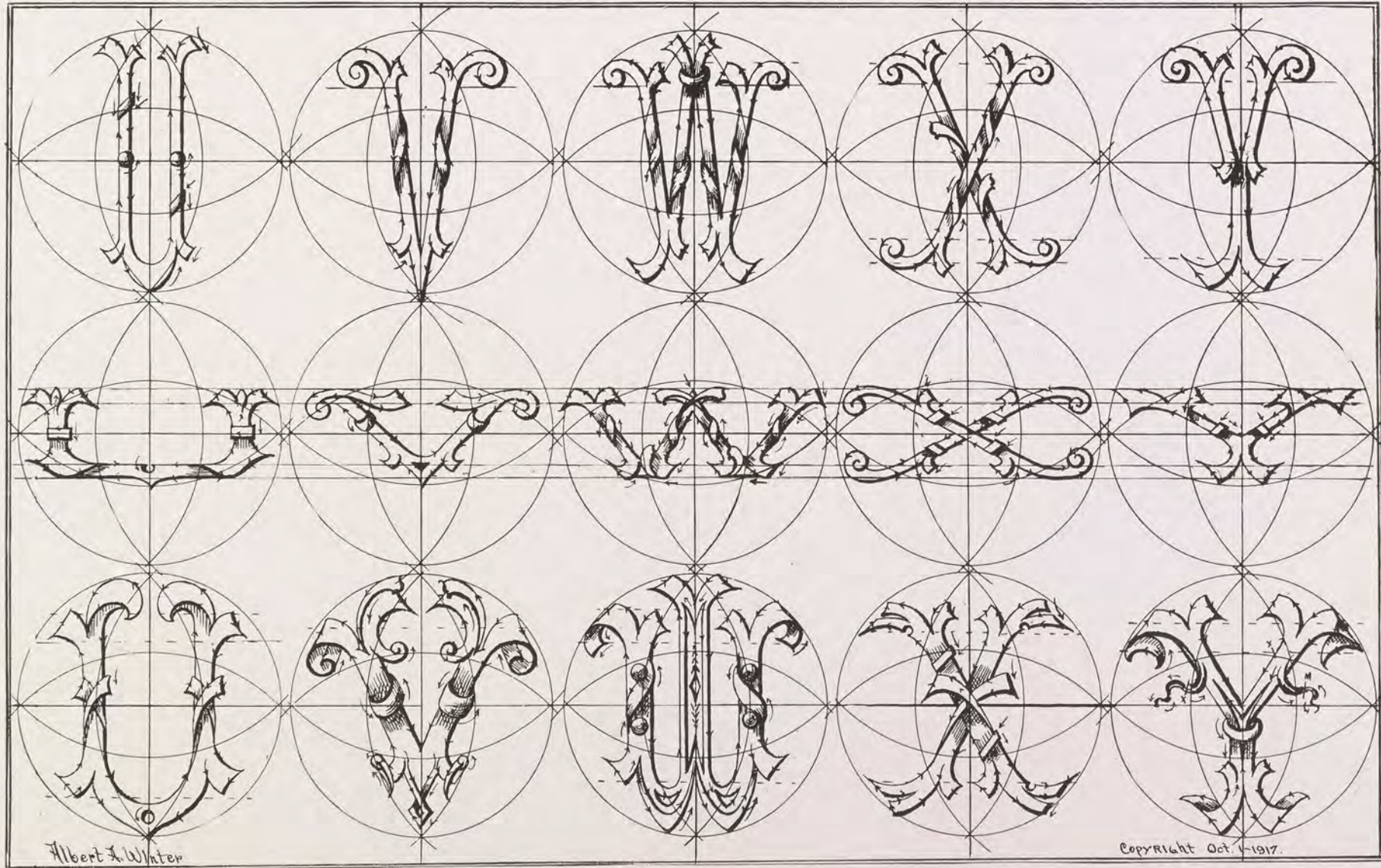


Albert H. Winter

COPYRIGHT OCT 1-1917

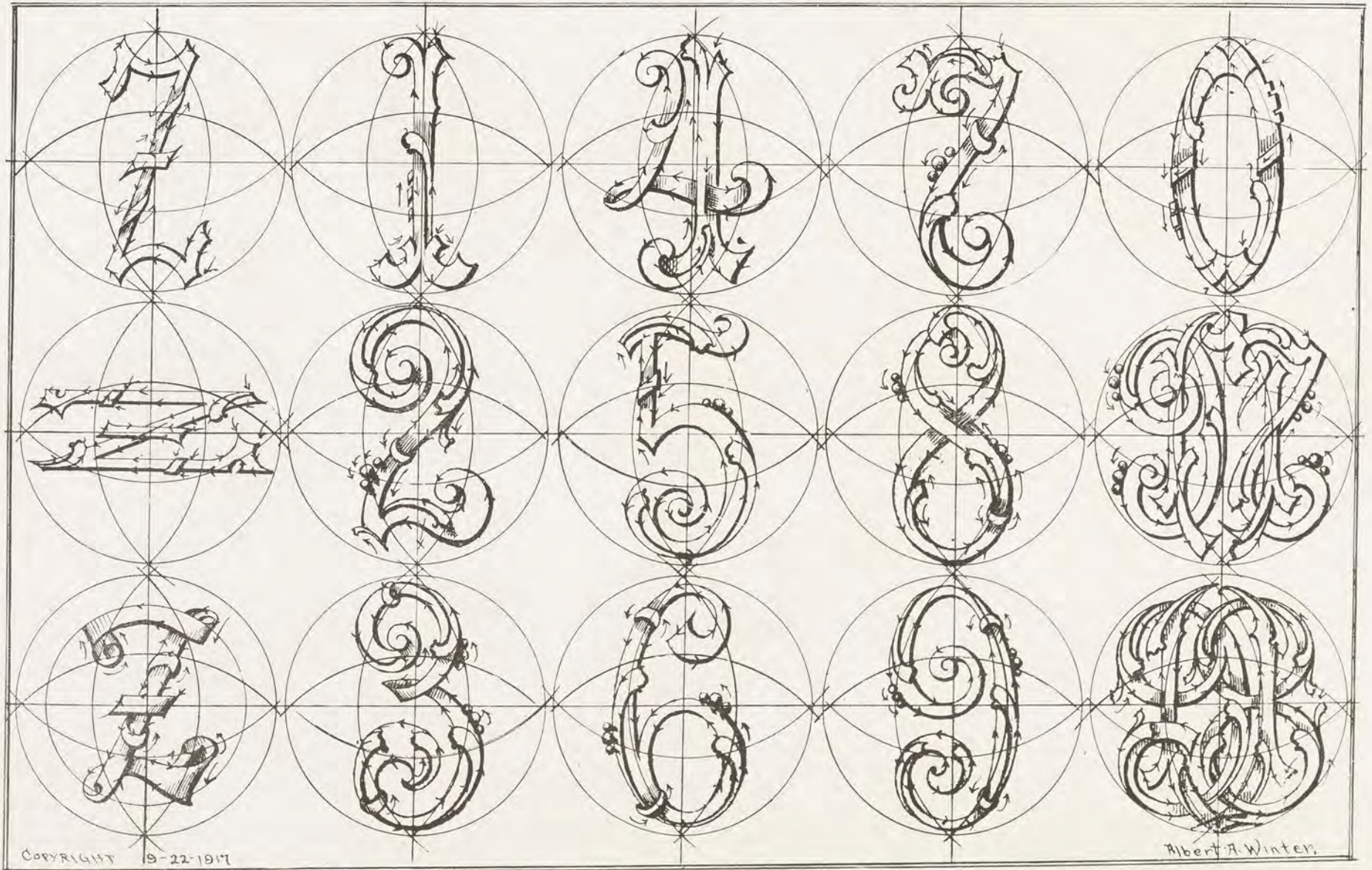
THESE LETTERS ARE TO BE ENGRAVED EITHER CLOSE LINED OR BRIGHT CUT ACCORDING TO SIZE

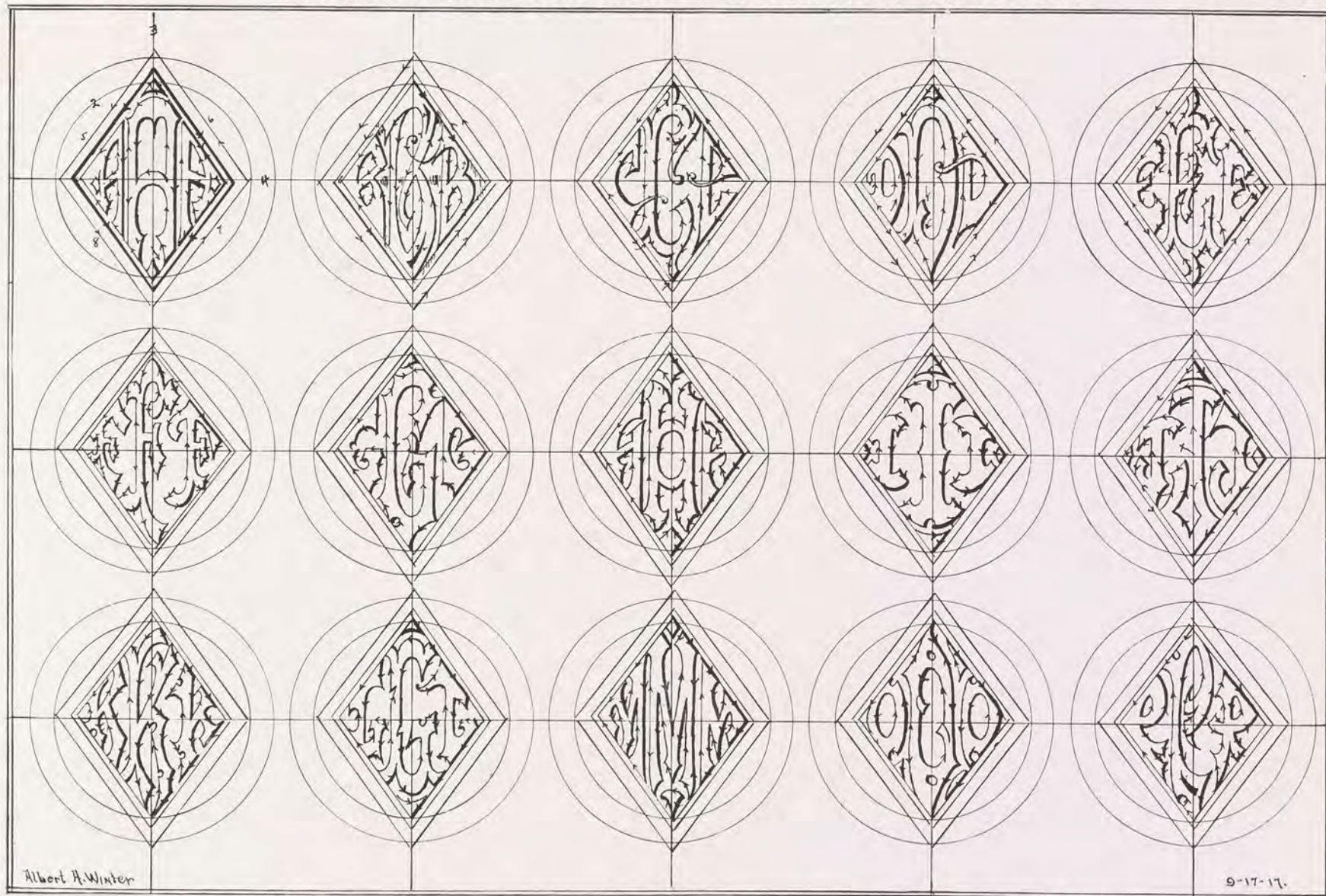
46-E



Albert J. Winter

Copyright Oct. 1-1917.

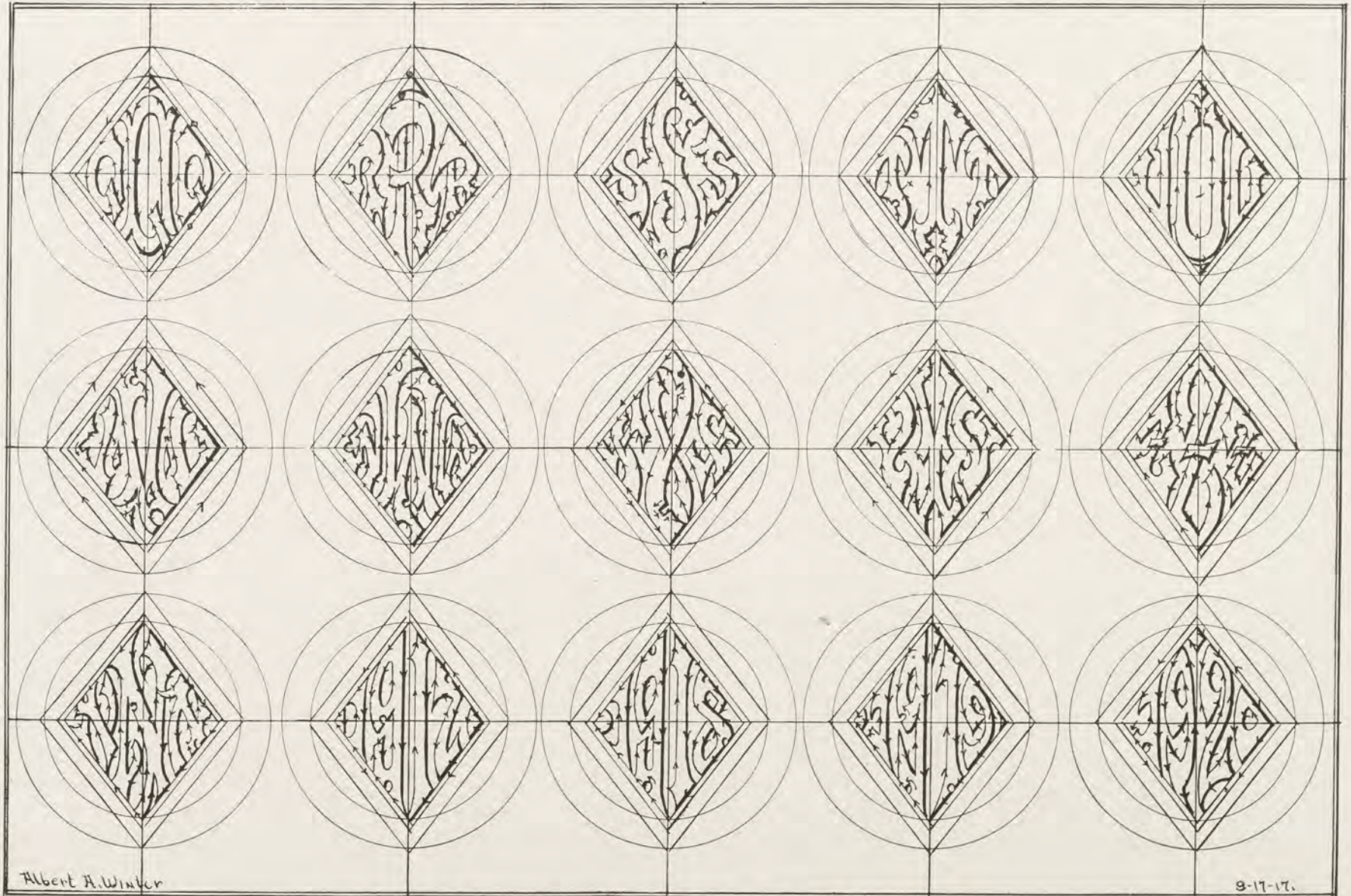




Albert A. Winter

9-17-17.

For Example, take Monogram A. A. A. Next B. and C., leave A. in Center and you have Monogram B. A. C., and so on with others—D. E. E. or F. G. A., Etc.



Albert H. Winter

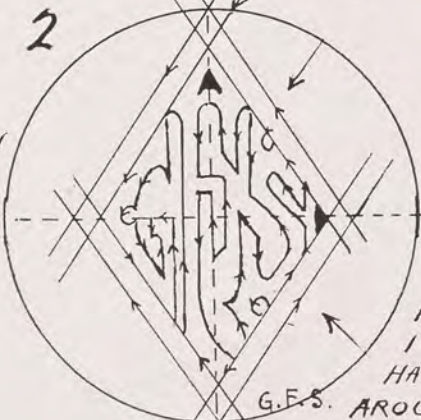
9-17-17.

Below Diamond Monogram dates 1917, 1918, 1919, 1920, Etc.

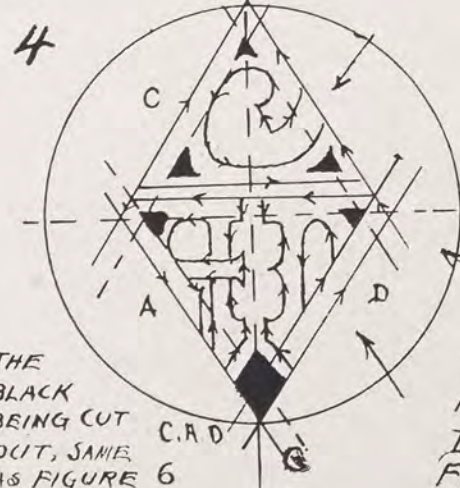
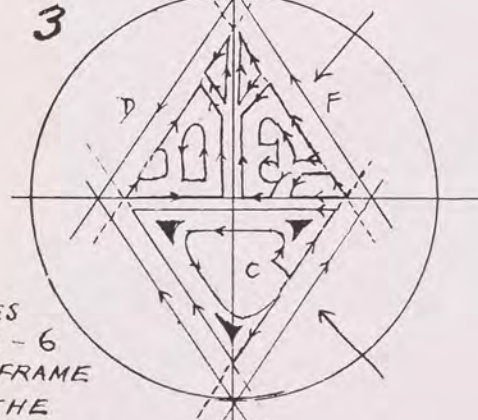
STUDIES IN DIAMOND MONOGRAMS.



SHADE WHICH MAY BE CUT IN ONE CUT OR CLOSE LINED,

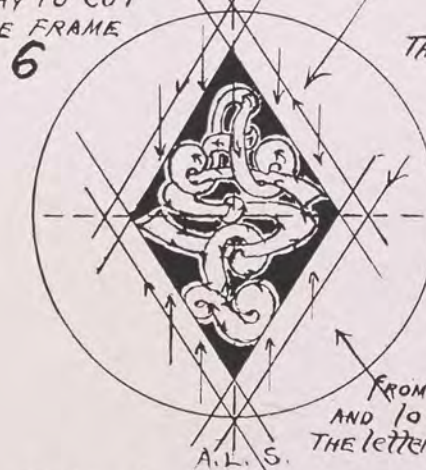
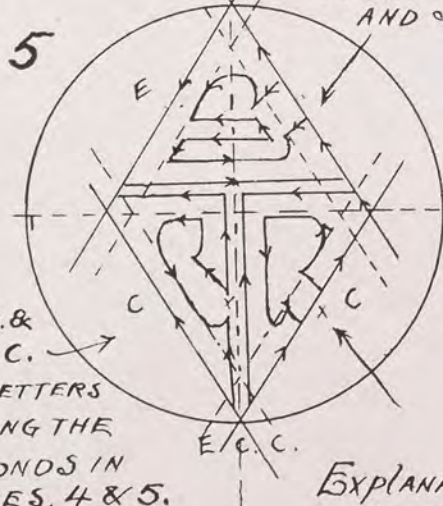


FIGURES 1-2-3-6 HAVE A FRAME G.F.S. AROUND THE LETTERS, ARROWS SHOW THE WAY TO CUT AND SHADE FRAME



THE BLACK BEING CUT OUT, SAME AS FIGURE 6

C.A.D. & E.C.C. THE LETTERS FORMING THE DIAMONDS IN FIGURES, 4 & 5.



THE LETTERS A.L.S. ARE OUTLINED 1ST THE FILLING IN, AROUND THE LETTERS WHICH SHOWS BLACK IS CLOSE LINED.

FROM AND TO THE LETTERS CUT DOWN.

EXPLANATORY RULE, FOR OUTLINING LETTERS
 ARROW ON THE LINE, → ← CUT THE WAY ARROW POINTS.

FIG 1. USE DIVIDERS TO BALANCE UP. FIG 2
TRIANGLES IN DESIGNING
 Following Nos 1-2-3
 2 SMALL TRIANGLES
 1 INSIDE FOR LETTERS AND CIRCLE ENGRAVING OF SAME AS FIG 3.
 1 BLACK-SHADES.

FIG 3. DRAWING OF THE CIRCLE 1ST.
 2ND SQUARES FOLLOW THE NOS. 3RD B.R. THE LETTERS ARE DRAWN NEXT.

FIG 4. W.S. OF ENG. 1915

FIG 5. M.D.B.

FIG 6. Code -
 A. HAIR LINES
 B. SHADES
 ARROWS POINT TO PLACE SHADES
 B.R. BLACK LINES - SHADES, AND CUTTING.

RULE FOR ENGRAVING > (All Lettering Being outlined 1ST)
 ↑ ↑ THE SPACE BETWEEN THE LETTERS MAY BE OPEN LINED OR CLOSE LINED, FOR EXAMPLE -

FIG 4

1ST THE DESIGN OF CIRCLE.
 2ND INNER CIRCLE AROUND THE LETTERS ENGRAVING OF SAME, AS FIGS. 1-2-3.

S.R.W.

FIG 5

MARGIN RINGS.

(FIG 5) THE LETTERS MAKING THE CIRCLE.

A.T.M. DROP CIRCLE

FIG 6

MARGIN RING

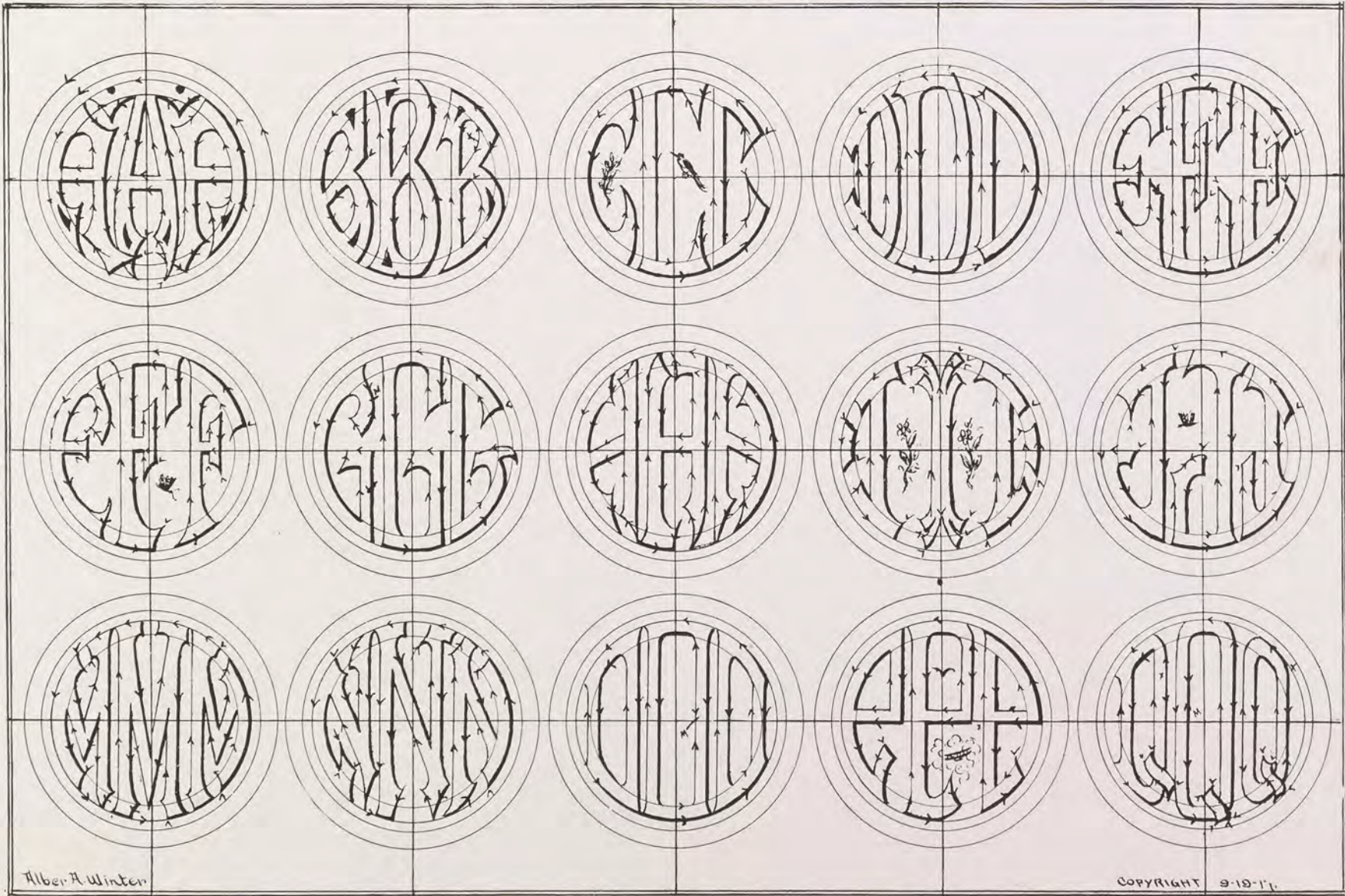
(FIG 6) THE LETTERS MAKING THE CIRCLE. WHICH MAY BE ENGRVD AS SHOWN IN CUT. CLOSE LINED, (BLACK)

T.F.K. DROP CIRCLE

Filling in around the letters cut up and down from and to the letters.

OR

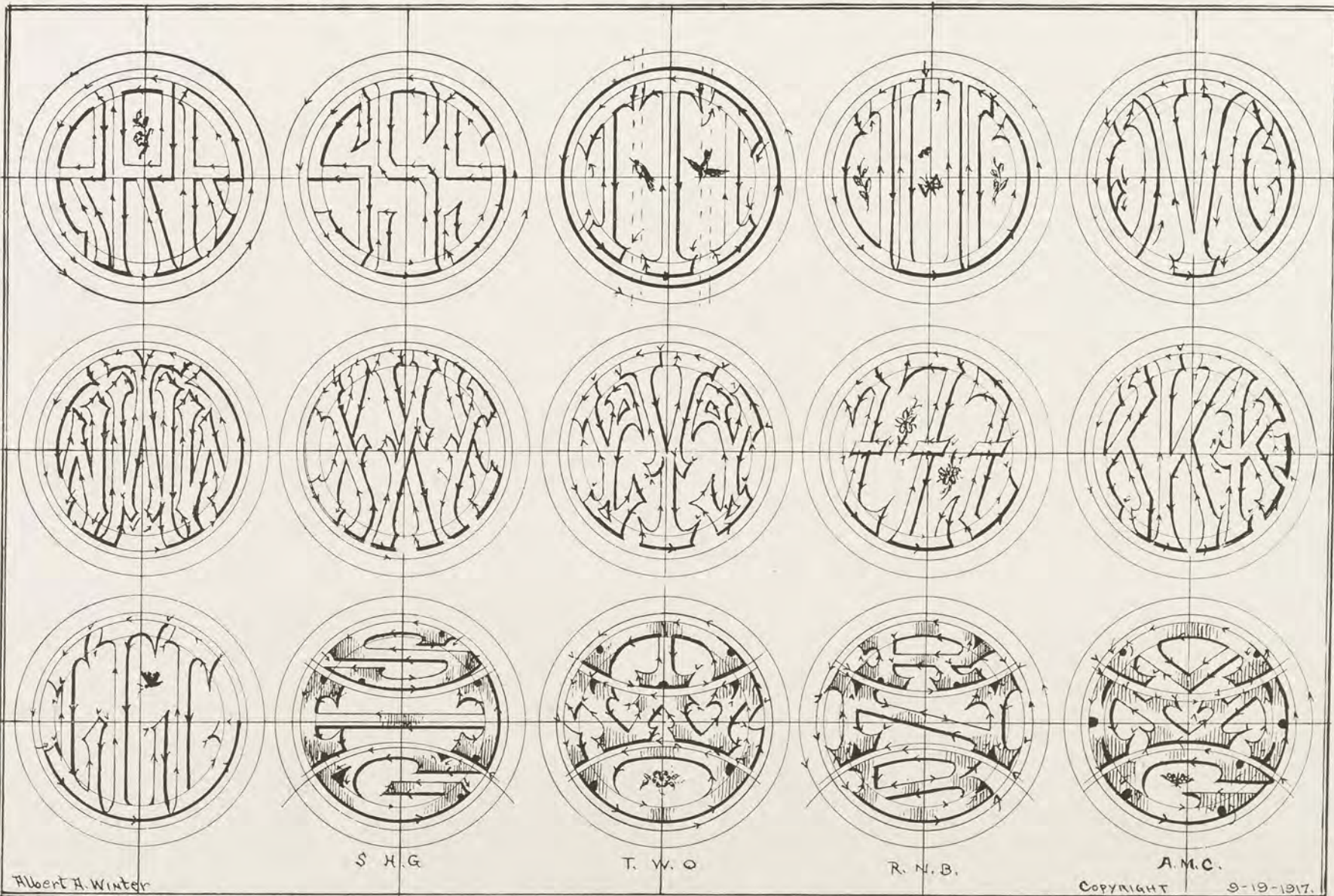
CIRCLE MONOGRAMS IN ALPHABET IN SIMILAR MANNER



Alber A Winter

COPYRIGHT 9-19-11

These Monograms look best size of Dime or Nickel, and smaller



Below Drop Circle, or Base Ball Style—the very latest

RUSTIC PERTAINING TO COUNTRY LIFE, RURAL; HOMELY; Plain; Simple:

FIG A, Shows letters DESIGNED, FIG B, Next cut with LINING tool. FIG C, Cross Cutting with LINER OR SQ. GRAVER FIG D, DARK SPOTS close lined, - Some BRIGHT CUTTING AND LEAVES. - FIG E, AND C, is called BIRCH, - WOOD. - WHITE BARK. ENGRAVED USE SQ GRAVER Close line fine, a KIND of TORN Effect, & some BRIGHT CUTTING. FIG A, DESIGNED AND OUTLINED. FIG D Completes the letter) Also FIG F.



FIG. A. FIG. B. FIG. C. FIG. D. FIG. E. FIG. F.

FIG 1. DESIGN, AND OUTLINE WITH GRAVER }
 1-2 CIRCLE
 3-4 LINES
 THRU CENTER
 NEXT NO 5
 THEN
 SQUARE &
 COMPAS.
 Black Lines are
 Shades,
 BRIGHT
 CUTS.

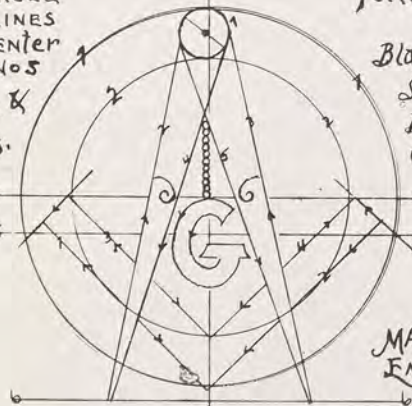


FIG. 1

FIG DESIGN, NEXT OUTLINE WITH GRAVER.
 The Black TRIANGLES
 Are close lined
 IN DULL EFFECT.
 FIG 4.
 Also Shield.
 OPEN
 LINED

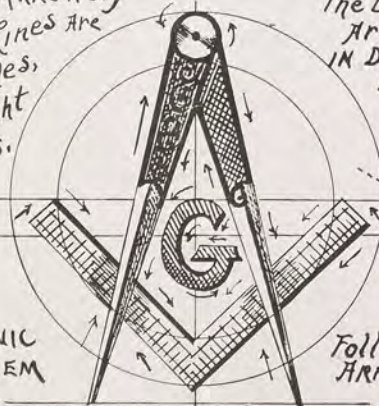


FIG. 2

Follow
 ARROWS IN CUTTING.

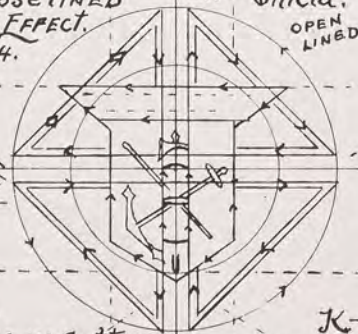


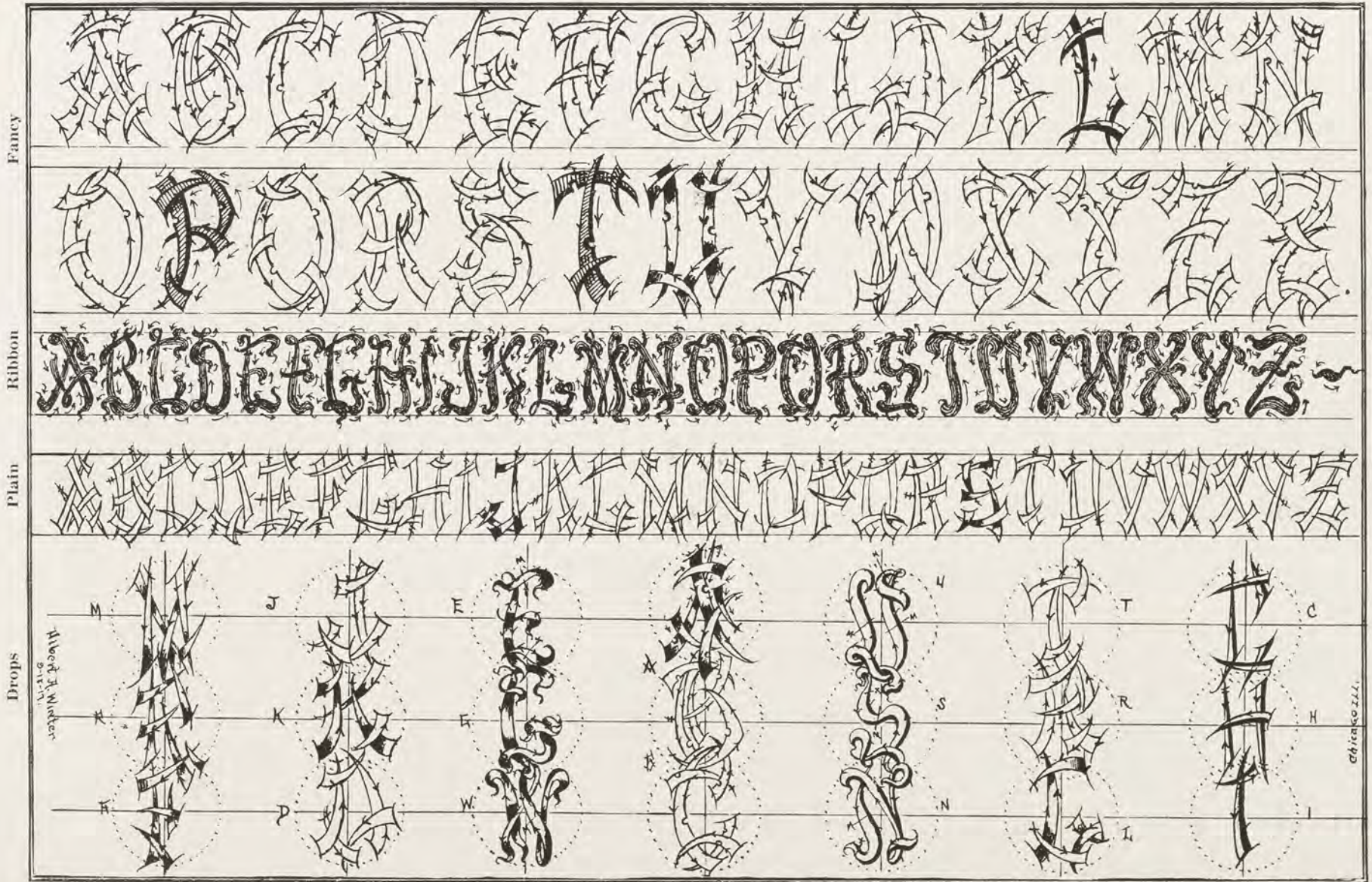
FIG. 3

FIG. 4. FINISHED
 Black Lines are Shades, BRIGHT
 CUTS.

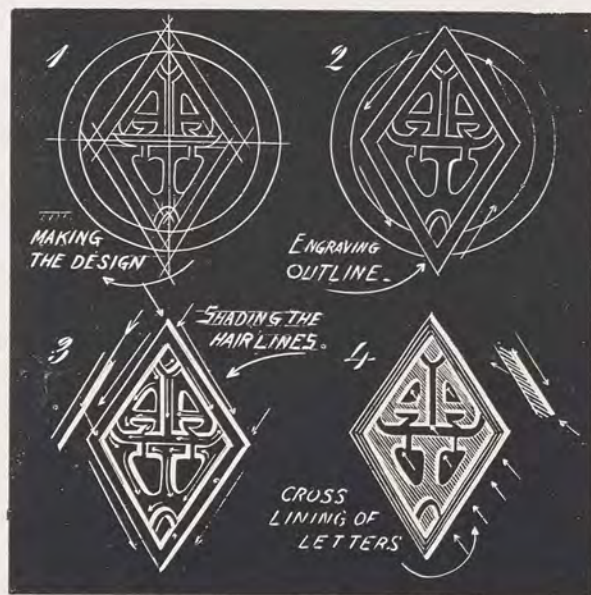


FIG. 4

How to go about to Design Emblems and Engraving of Same. Effects, close line and bright cutting which show Heavy Black

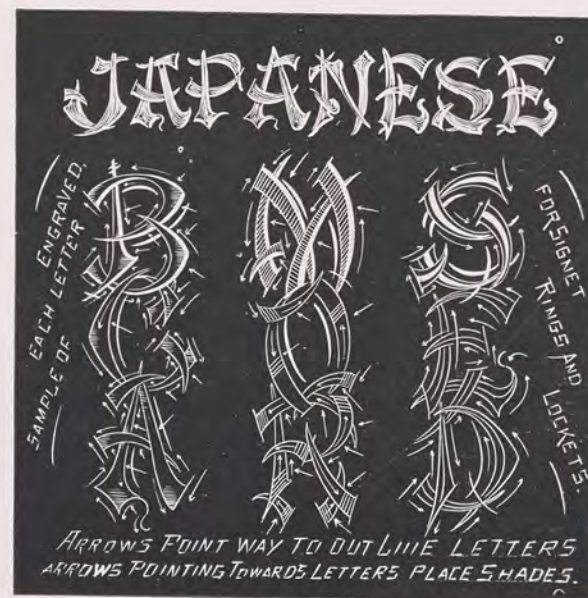


Drop Letters in Japanese showing same styles, for any purpose



DESIGNING AND ENGRAVING OF JAPANESE LETTERS

First make a rough sketch, single line drawing as for double line Old English, or double line cipher monograms. Next draw a line each side of line already drawn, then proceed with outlining, and filling of the letters as shown in chart.



THE DESIGNING OF CIRCLE MONOGRAMS

First draw a circle, then draw a line straight up and down, next draw the cross line. Draw in letters to shape to the circle. The usual process of engraving follows. See the charts, No. 47, Page No. 48. Any style of letter can be employed.

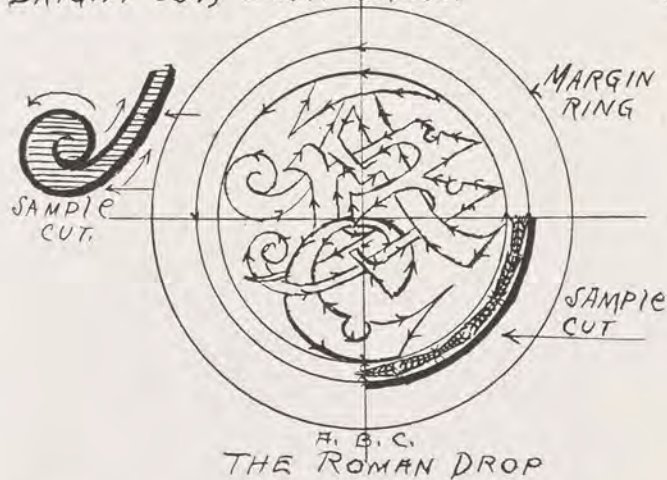
THE DESIGNING OF DIAMOND MONOGRAMS

Use the same system as for circle monograms. Determine the width of diamond desired, also its length; the style of letter preferred. Sketch in as for circle monograms and engrave as shown in charts. These monograms can be engraved in pearl, celluloid, etc., by following the rules laid down in another part of this book for engraving on these kinds of materials.

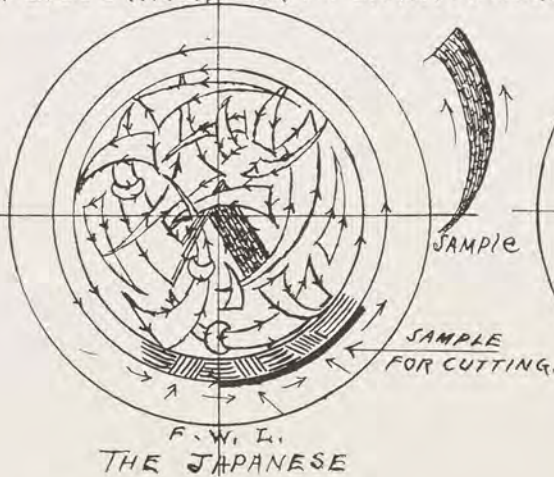
Note.—In designing the letters for diamond and circle monograms, the letters must be drawn to conform with the design of the diamond or circle—some original ideas are preferable—however one must try and work out the letters to the best of his or her ability.

NOVELTY MONOGRAMS

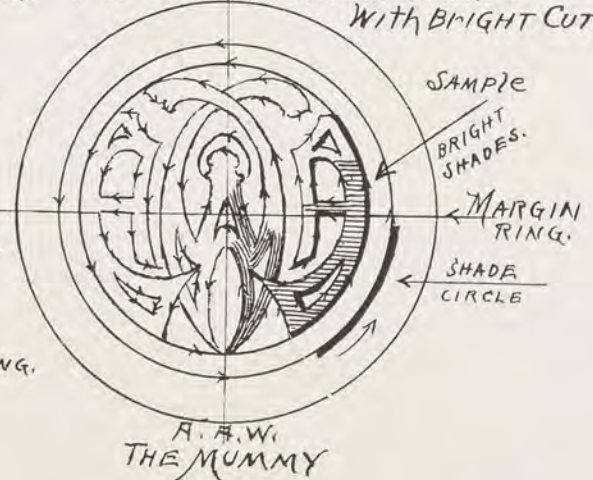
ENGRAVING OF A.B.C.
CROSS LINE SHADED, OR HEAVILY
BRIGHT CUT, BOTH SIDES.



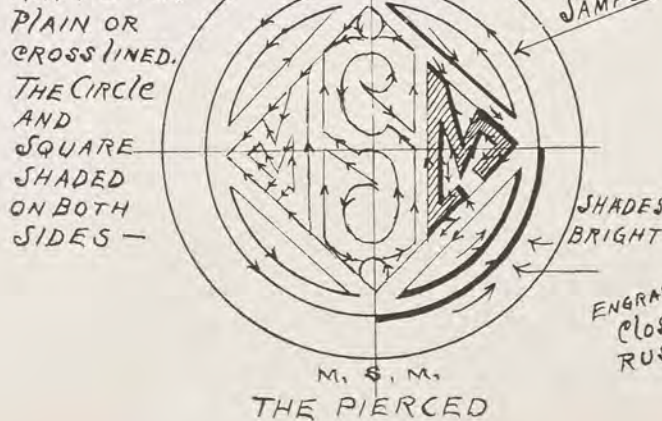
ENGRAVING OF F.W.L.
Which MAY BE CUT LIKE A.B.S.
OR CLOSE LINED OR IN STRAW EFFECT.



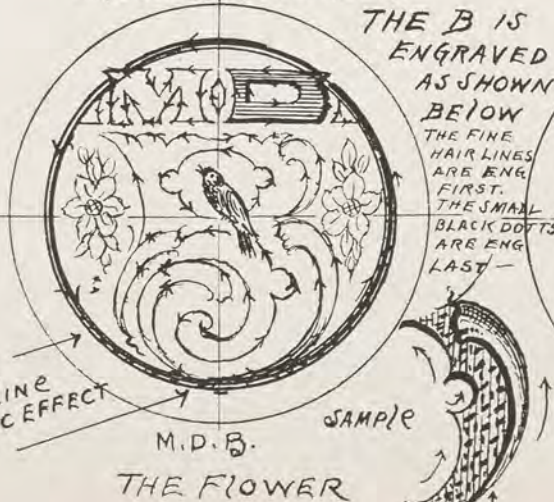
ENGRAVING OF A.A.W.
MAY BE LINED AS SHOWN BOTH A'S
AND THE 'W' RIBBON LINED -
WITH BRIGHT CUTS.



ENGRAVING OF M.S.B.
SHADED WHERE ARROWS
POINT TO, WHICH
MAY BE left

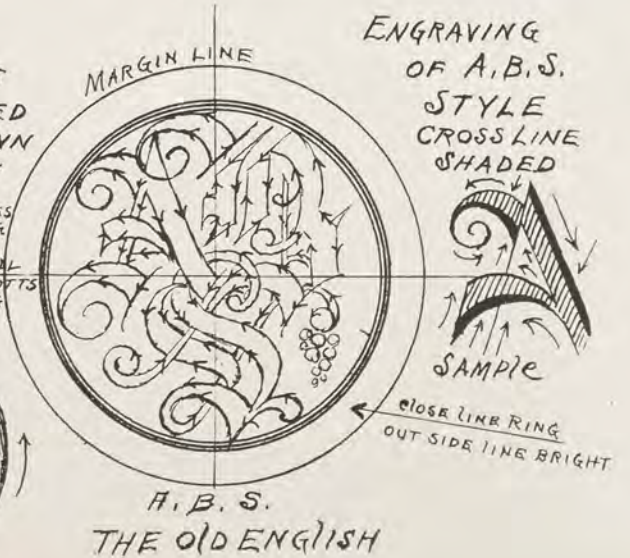


THE LETTERS M, D, ARE
CROSS LINE SHADED.



THE B IS
ENGRAVED
AS SHOWN
BELOW
THE FINE
HAIR LINES
ARE ENG.
FIRST.
THE SMALL
BLACK DOTS
ARE ENG.
LAST -

ENGRAVING
OF A.B.S.
STYLE
CROSS LINE
SHADED



PROPER MARGINS TO LEAVE.

USING THE DIVIDERS TO FIND CENTER LOCKETS-WATCHES.

FOR PLAIN
OR FANCY
SCRIPT
MONOS.

FOR CIRCLE

MONOGRAMS
OR CROSS
LINE LEAF
OR SHADED
O.E.
L'trs

Old English Letters on Shields

OF WATCHES
MAY BE CUT
IN ANY STYLE
When CASES
ARE HEAVY

CASES THAT ARE
THIN, VERY LIGHT
ENGRAVE THEM
CLOSE LINE
IS BEST.

MONOGRAMS
ON SHIELDS OF
WATCHES SHOULD
BE ENGRAVED IN
BRIGHT CUT.
SHADES -

THE LETTERS
BEING
OUTLINED
1ST, THEN
SHADED.

FIG 1



FIG 2

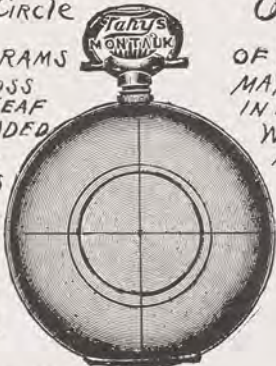


FIG 3



FIG 4



FIG 5



SIGNET RINGS IN GOLD

LETTERS
BRING
OUT
LINED
FIRST.

THEN SHADED
BRIGHT
CUT
Solid

RE-CUTTING
THE SHADES
OVER
SEVERAL TIMES

BRINGING OUT THE BEAUTY
OF THE SHADES.

FOR
DIAMOND
MONOGRAMS
WITH OR WITHOUT FRAMES.
DRAWING THE CIRCLE FIRST.

Gold or
Gold Filled.
When CASES ARE THIN
CLOSE LINE THEM LIGHTLY.



FIG 6



PROPER
FOR ANY STYLE
IN SCRIPT

MARGINS TO LEAVE
MONOGRAM - Circle
LEAF, OR ROMAN -

FOR WATCH
CASES -

CORRECT WAY TO ENGRAVE CUFF BUTTONS.

LINKS THAT
ARE VERY THIN
ENGRAVE THEM
LIGHTLY - IS BEST.
CLOSE LINE THEM.

LEAVE
MARGIN
AROUND

LINKS THAT ARE
HEAVY - MAY BE
ENGRAVED IN
Solid BRIGHT
CUT SHADES -

FIG 9



FIG 10



FIG 11



FIG 12

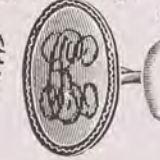
WHICH MAY BE THIN, OR HEAVY.

THESE LINKS MAY ALSO BE ENGRAVED
IN THESE POSITIONS.

Old ENGL.
LETTERS
2 or 3
CAPTS,
Also IN



FIG 11



UP AND
SINGLE
O.E.



DOWN
CAPITALS
L'trs.

SCRIPT AND O.E. NAMES & ETC.

GOLD FILLED
CASES -
CARE
MUST BE
TAKEN
NOT
TO
CUT
THRU
THE
PLATE.

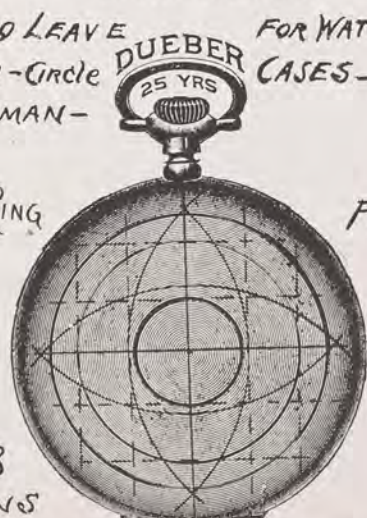
FIG 7



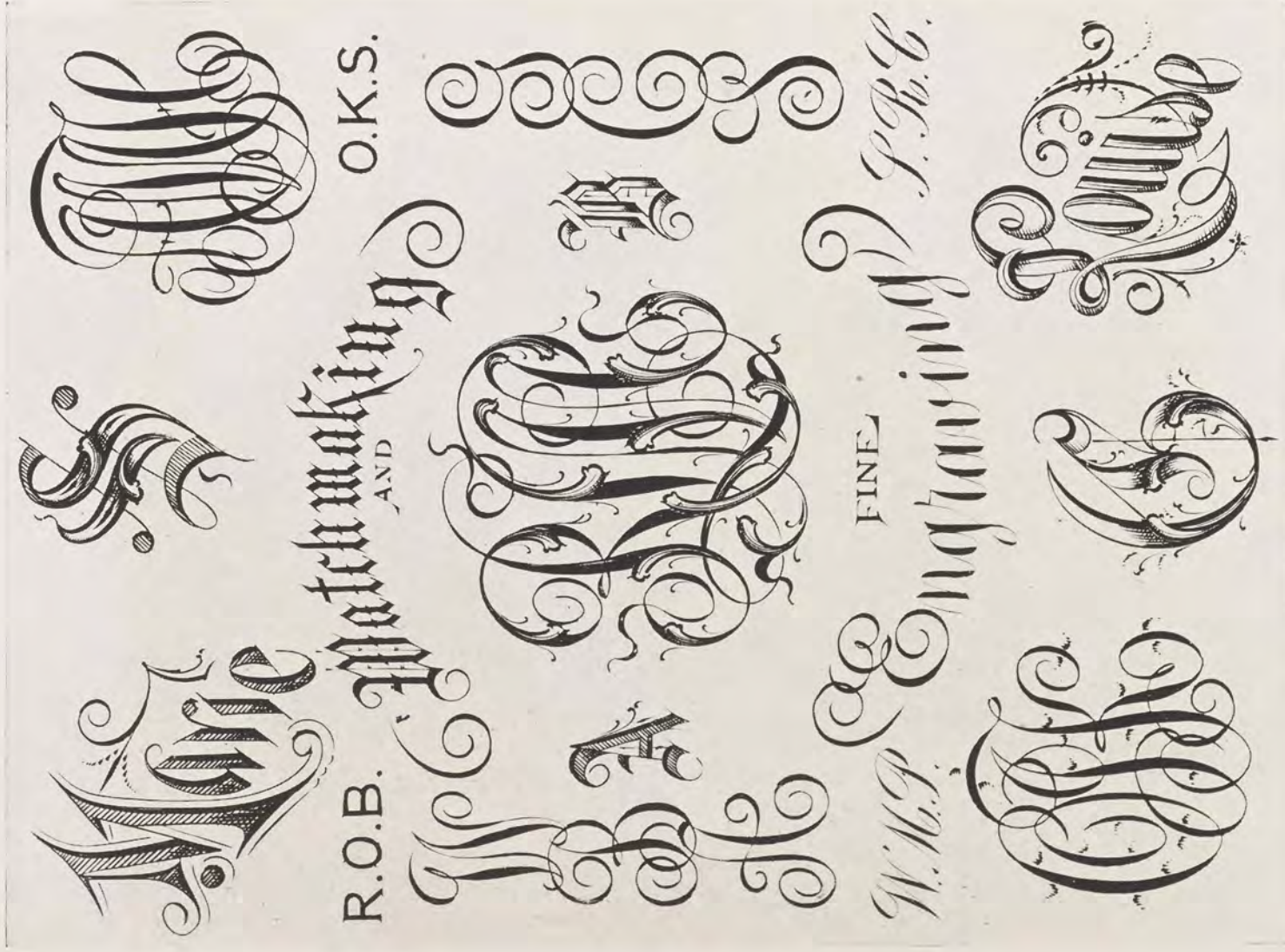
MARGIN RING

FIG 8

MARGINS



UNLESS OTHERWISE ORDERED BY CUSTOMER - OR JEWELERS.



DISPLAY PLATE OF
CELLULOID ENGRAVING







Monogram L. W. R.

DESIGNING AND ENGRAVING ON CELLULOID GOODS

Practically the same methods obtain here as employed on metals. First, Chinese white the article, thickly using the dividers to find the center. Draw letters or monograms with a very soft lead pencil, lightly at first, later touching up the details here and there, which is now ready for the engraving. As the thickness of celluloid varies, determine how deeply you can safely cut without cutting through. Filling of the engraving can be accomplished with common school wax crayon in any color procurable at any school store. Scrape away the surplus wax with a rubber marker or a piece of straight celluloid rule, which will not scratch—polish the surface of the celluloid which is engraved with a piece of tissue and with the palm of the hand, which keeps the wax in the cuts and puts on a glossy finish.

The best cutting results are obtained with a square graver, well-beveled, which is least likely to tear or chip the celluloid.

HANDLING SILVERWARE

In handling silverware, care should be exercised to avoid scratching it. Always lay spoons down with their bowls upright and forks with their prongs downward. In engraving either knife or fork, slip down the protecting tissue paper to its shoulder. The reason for this is to save time, as no extra wiping is necessary, except to clean the handles only. Some engravers place their hands all over the polished goods, scratching and leaving finger marks on article.

IMPRESSIONS

TAKING IMPRESSIONS OF SMALL ARTICLES for the purpose of duplication. Spoon handles, bowls, cuff links, signet rings, locket, forks and handles of knives. We make a wax suitable for this work with which the best and quickest results are obtainable, which may be obtained through the Winter School only.

First soften the wax by kneading it with the hands. Rub lightly with the finger, a little magnesium powder into the cutting letter or monogram, which the article is to be transferred from and to be duplicated. See that the magnesium powder is in the cuts only. Press the engraved article against the kneaded wax. The wax will then show an impression of the design in the white magnesia powder. Rub your finger over a piece of moistened transparent soap and then rub it over the article to be engraved, after which, press the article into the wax with firm but gentle pressure and your impression will be ready for engraving.

On satin finish metals substitute pulverized willow charcoal for the magnesium powder, using it in similar manner as described above.

POLISHING OF SCRATCHED ARTICLES BEFORE ENGRAVING

All articles which are scratched must be first polished before the work of engraving is begun. If the polishing is done after the engraving, the appearance of the design will be affected. All its sharpness will be lost. It will lack that rich luster so pleasingly characteristic of hand engraving. In fact, it will have the appearance of having been machine-engraved.

Start, therefore, with a clean, smooth working surface. After the design or lettering has been cut, take a light, soft cloth which has been saturated with ammonia and clean out the cuts. This will leave the design or lettering bright and clean.

BRIGHT CUTTING OF ALUMINUM

The method of **bright cutting Aluminum ware** is similar to that of other metals. The chief difficulty, however, in handling this metal lies in the bright cutting. It can be overcome by keeping the graver well polished and constantly wetting it in coal oil, while working. The polishing should not round the graver, otherwise it will not cut sharp. Turpentine or alcohol may be used instead of coal oil. Use 4-O emery paper on a flat piece of glass when polishing graver.

Scratched aluminum is best polished with Winter's Prepared Rouge, a preparation of ours which gives a high polish.

TO POLISH ENGRAVING, which is closelined in dull flat effect, on watches, locket, whether gold or silver, first buff lightly and clean with ammonia, using tissue paper or soft cloth to clean out the rouge in the cutting. The design will then show up attractively. Small lettering similarly engraved in block, script, also monograms dull engraved can be polished in the same way. **Note.**—Care must be taken not to polish engraving excessively.



Monogramming on Ivory in Colors

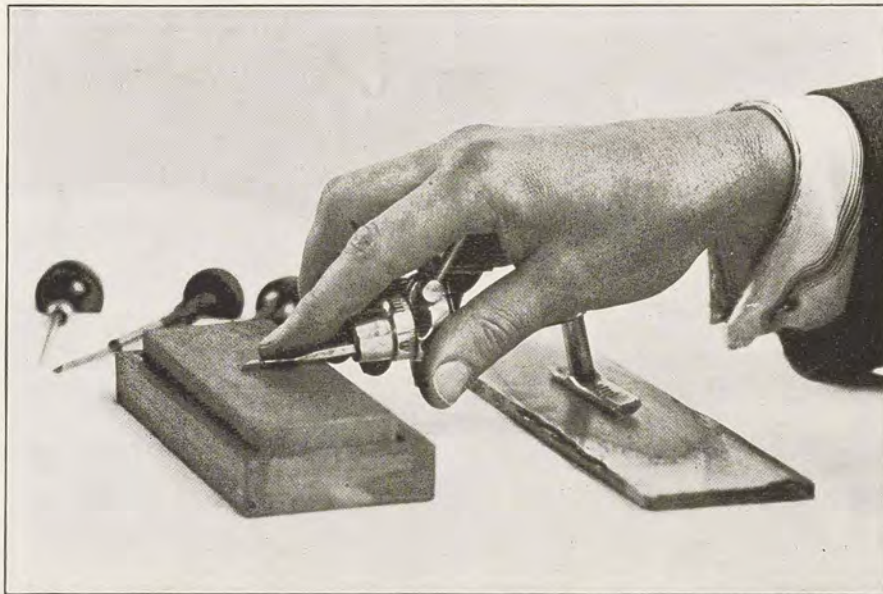


Fig. 1

**Round
Gravers**
Nos. 53-54
for inside of
Rings,
Spoon
Handles,
Napkin
Rings
and other
concave
surfaces.
ANGLES:
54-A
To Right.

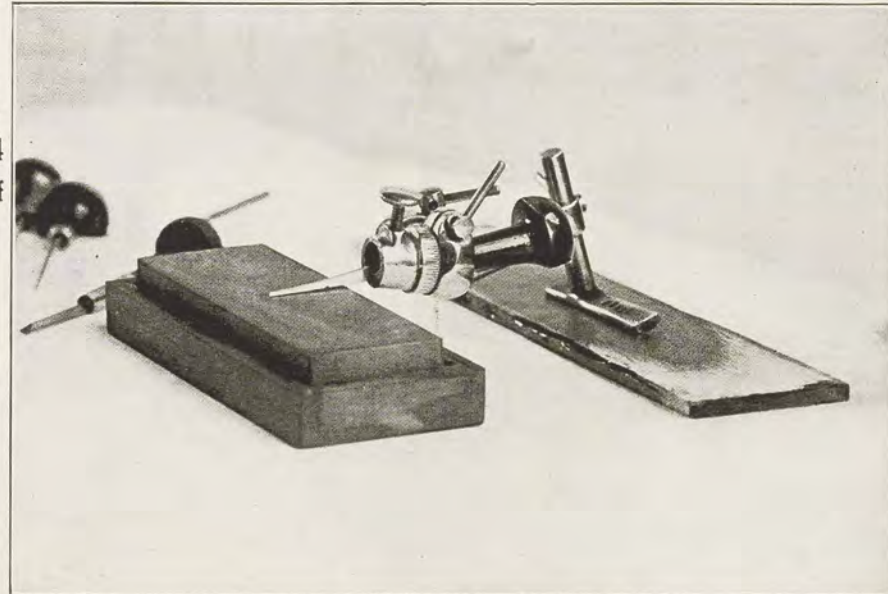


Fig. 2

The Square Graver

Nos. 8 and 9

For cutting on Watch Cases, Signet
Rings, Watch Caps, Cigarette
Cases, Etc.

ANGLES:

Flat, Medium and High Heels

Illustration shows flat heel for
articles that have no obstructions
such as pins and high ornaments

See Illustration Page 54-A. Square Gravers
Center

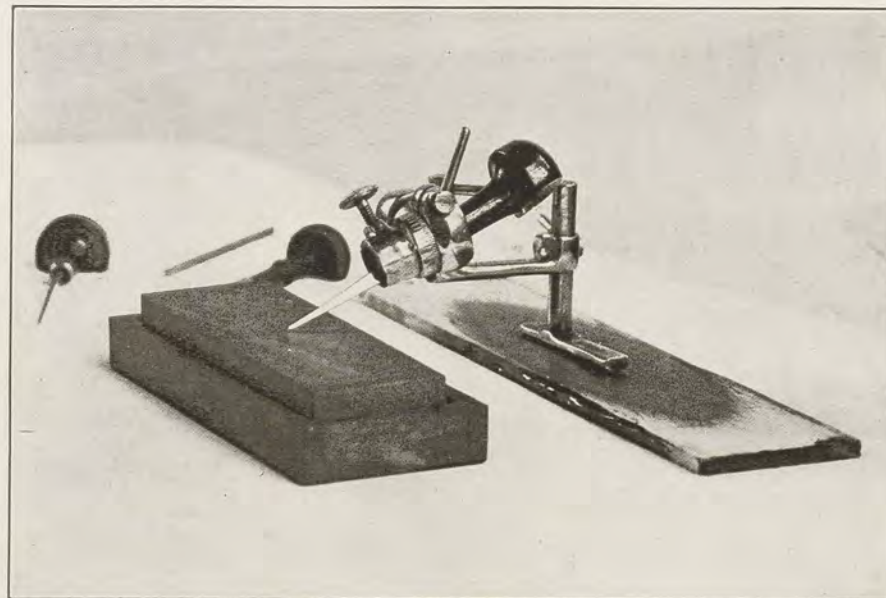


Fig. 3

The Flat Graver

Nos. 36 to 46

Set up Flat, Medium and
High Heel

For Block, Old English Lettering
for either Flat or Hollow and Con-
cave Surfaces.

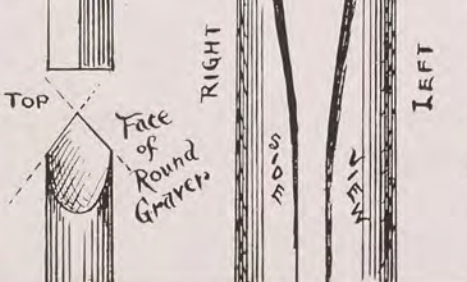
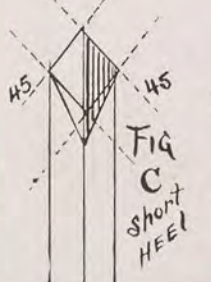
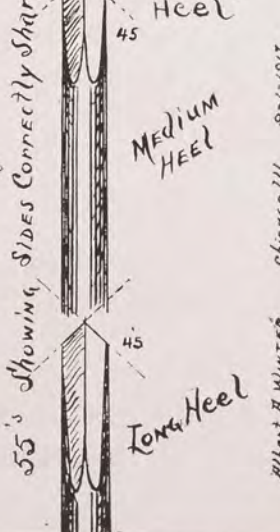
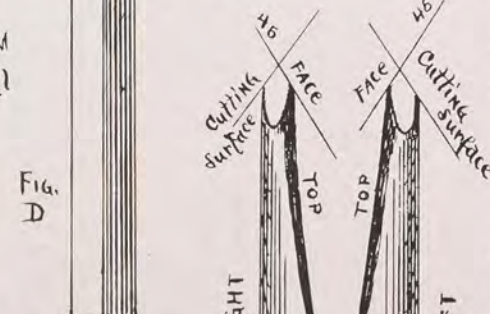
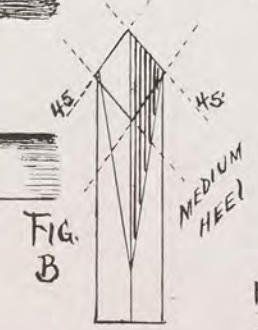
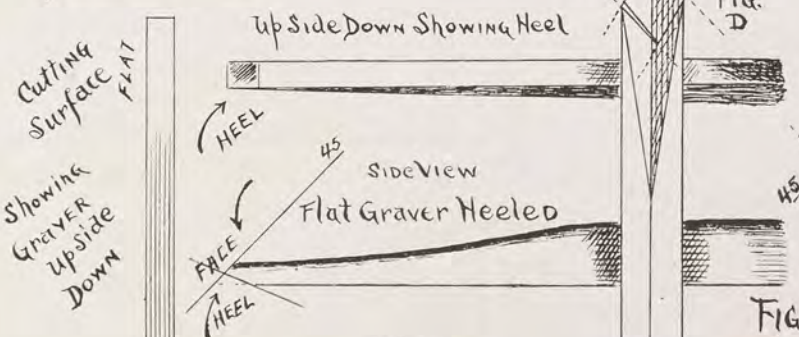
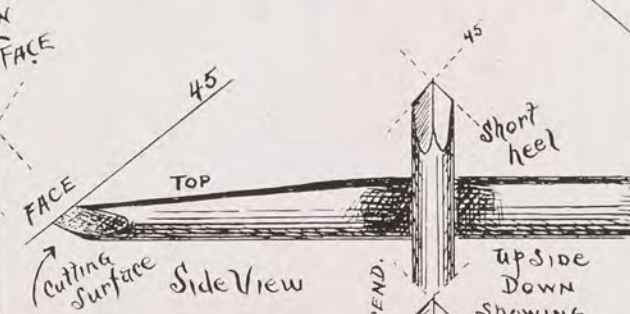
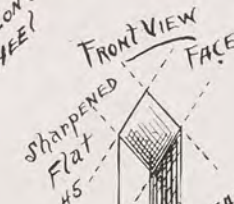
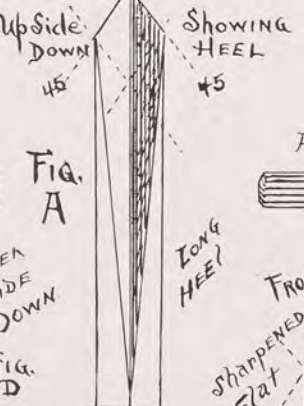
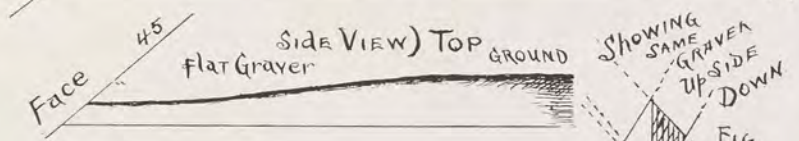
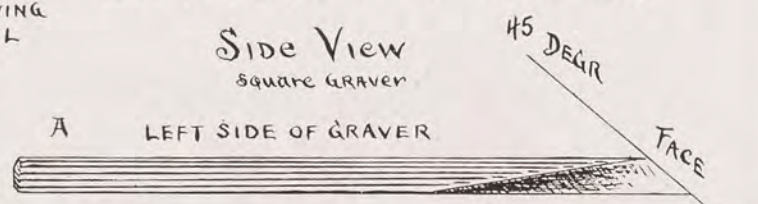
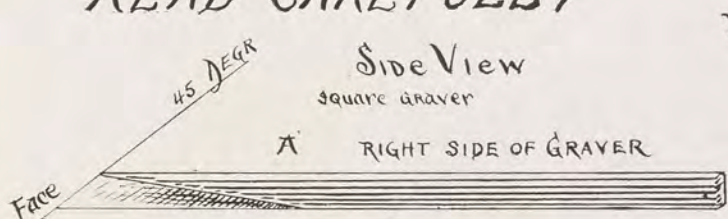
See Illustration Page 54-A to Left

Crocker or Plumer Sharpener used.
India Oil Stone—Medium. Glass
to Slide Sharpener, and Coal Oil.

AL. A. WINTER

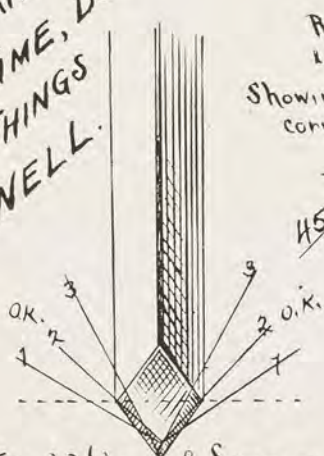
READ CAREFULLY

BE ACCURATE ALWAYS.



Albert A. Winter Chicago Ill. 9-1-1917.

TAKE TIME, DO THINGS WELL.



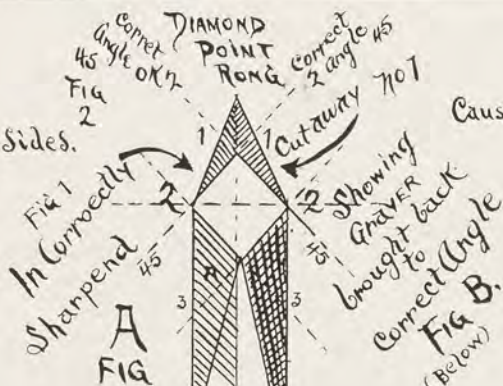
Front View of Square GRAVER

Fig. 2 correct Angle
Fig. 3 DIAMOND POINT
Fig. 2 Spread Face.

Front View of Round GRAVER No 54 & 55.

Showing Correct angle for Shading and Hair line Work.

Round Graver upside down Showing How to cut away Sides. correct correct Angle.



Showing Graver upside down.

Cut away No 1
Cut away No 2

Fig 3 Showing Sides Spread and Wide Face

The light Parts "D" show Graver brought back to Normal Shape Also FACE like Fig 2

FIG B. WATCH EVERY LITTLE DETAIL

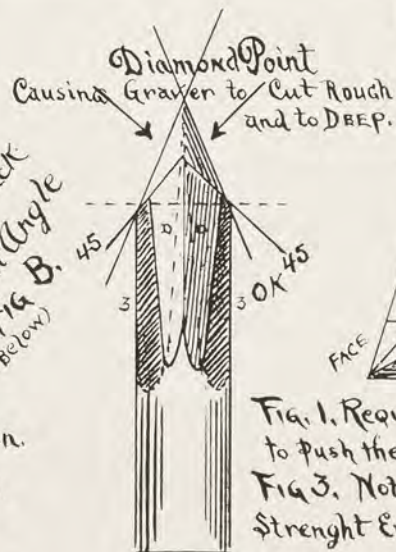
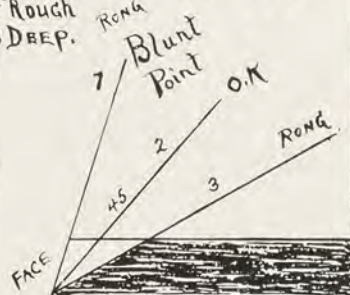


Fig. 1. Requiring more Power to push the Graver.
Fig. 3. Not giving the point straight enough) Points Snap Easily.

IT PAYS (TRY IT)



GRAVERS Square, Flat, or Round. Face (Gravers.) is NOT to be SHARPENED (BLUNT.)

SLIPPING AND FIXING OF SLIPS WHEN ENGRAVING

Practice, which is the best teacher, and makes the master, is the best preventive of slipping. Knowing how to sharpen the graver and proper use of same and good control. Graver sharpening which is quite a study in itself, as usually the pupil or advance student who engraves does not know how to sharpen a graver which is not taught in most schools. Think of a carpenter building a house and not knowing how to sharpen a saw or tools. You can imagine results—a complete failure. One reason so many engravers slip is because their gravers are heeled too high. The sides are round, the keen edge is like a bevel, caused by too much polishing; other causes are gravers too hard, and not well drawn to straw colors. Still other causes are gravers being too soft, which do not hold a point while engraving, incorrect way of cutting, twisting and curving shades, which break more points than anything else.

Only articles, such as gold or good gold filled goods or sterling silver can be burnished. When burnishing slips be sure and burnish from left to right. Like a cut on a

finger, it closes the parts together, kind of blending the burnished parts at the extreme ends. Never attempt to burnish satin finished or gilt articles, always engrave a scroll or fancy work over it.

Articles of French gray finish of any kind when scratched, after engraving: use pumice stone to bring back the original finish, always rub up and down or from right to left, using a piece of cloth with pumice, a little coal oil added. Fine emery can be used, also tripoli; this method may be used on other articles, also.

INSIDE RING ENGRAVING

When engraving initials or names inside Tiffany rings or flat band rings, always begin from the setting, or stamp mark 14K, working around to the right. Script lettering should be somewhat straighter, about 55 degrees slant or angle. First whiten the inside, and find the center, next draw a line above and below, leaving a margin. Small letters should be one-third and capitals two-thirds high, using a heeled graver for engraving. In cutting a cross shade of an L, D, or Q, use a higher heeled graver, using the same graver for small letters, such

as crossing small t's; bent gravers are not necessary; a straight graver Round No. 55 is best, such as we use for our school work; for inside of bracelets, the same gravers are used. Never have the lettering too large; smaller lettering is best, looks neater, and is easier to engrave.

HOW TO HOLD VARIOUS KINDS OF RINGS WHEN ENGRAVING AND HOLD THEM SECURE

When engraving signet rings, get two pieces of flat, soft lead bars, place the ring between and place them in the engraving block, other rings similar, which may be tightened as hard as you like without injury.

GRAVER SHARPENING

Graver sharpening, which is very difficult to explain and demonstrate, even with illustrations, is best learned through us. We will give lessons free until mastered. Always use kerosene (coal oil) only, which will cut faster and not gum up the stone. Use only the India combination oil stone, fine and medium.

ENGRAVING FILLED CASES

Care should be exercised not to cut into the brass. Some cases of a better grade will stand heavier cutting than others. Have the graver in first class cutting condition and keep it so while the work is being done. Engrave lightly and cut very flat.

ENGRAVING GOLD WATCH CASES, SHIELDS, ETC.

The above procedure for small monograms holds here. Test the metal first to determine whether it will stand solid cutting. If thin, it must be close lined and finishing touches of bright cutting delicately done. Other small articles in this class—cigarette cases, small, thin-cased ladies' watches, gold or silver-topped umbrella handles, etc.

ENGRAVING SMALL MONOGRAMS, SUCH AS SIGNET RINGS AND SHIELDS OF WATCH CASES, ETC.

First outline with hairline, after which shade with bright cut, going over several times to deepen the shade and get the desired effect. Shadings should be fairly wide but should never touch one another.

ENGRAVING LARGE SCRIPT ON LARGE ARTICLES

In this class come Loving Cups, Trophy Cups, Dishes, Tea Sets, Platters, Trays, and other similar large-sized articles of solid silver or gold filled goods. The script must be close lined in dull effect. The graver must not be polished. The finishing cutting in bright cut shade, as in monograms.

In engraving script on large articles, such as loving cups, tea sets, dishes, punch bowls and other goods, it should be close lined with a dull, unpolished graver. The very last cut should be bright engraved to give the desired effect. The metal itself being bright, the flat cutting and bright shading afford the necessary contrast.

Smaller letters are bright cut, in the usual way, on such articles as spoons, watch caps, napkin rings, etc.

If script must be engraved on hard metal, it should be close lined and cut flat with unpolished graver, as no bright cutting can be done.

MONOGRAM ENGRAVING OF POLISHED GOODS

such as watch cases, locket, cigarette cases and the like, also other articles such as silver tea sets, silver novelties, should preferably be done in close line, dull effect, with a bright cut shade as the finishing touch, although the close lining may be done in bright cutting, if desired. Satin finish goods are also handled as above, closeline leaf monograms. The filling in of the leaves is done in dull effect, concave side of each leaf being cut bright, also the tip of leaf and rounded parts of stems. (No. 2, p. 36.) Note heavy white lines. Large script should be close lined in dull effect with shades cut bright as in monograms and Old English and block letters engraved similarly. The use of non-polished graver on polished goods as well as on any other bright finished metal will prevent slipping. A trial will demonstrate that this is the most practical way—even on satin finished goods.

ENGRAVING ARTICLES OF SILVER

Such articles should be handled with as much care as in the instance of articles mentioned above. If the silver article is thin, have the graver in first class shape. Employ closed lined engraving, working lightly. If the article is heavy, heavier cutting can be done—possibly bright cutting, i.e., solid one-cut shade.

ENGRAVING INSIDE OF DISHES AND BOWLS, CAKE TRAYS, ETC.

The use of bent graters are a necessity for this sort of work, which may be obtained through us, properly bent and sharpened.

After the designing has been done, it should be retraced into the article with a steel point because while cutting the design may be rubbed off, which of course is a waste of time, and better results are obtained in cutting; after retracing is done, the white should be cleaned off, and then proceed with cutting.

ENGRAVING SOFT WHITE METAL GOODS IN BLOCK LETTERS

Proceed as above for hard metal goods, using bright cutting instead, if preferred, solid cut with one cut of graver in the smaller sizes of letters.

DESIGNING AND ENGRAVING SEAL STAMPS

DESIGNING AND ENGRAVING SEAL STAMPS in block script or monograms. First whiten surface of article with Chinese white. Take a piece of tissue paper and lay a piece of carbon paper over the lower half of it. Fold the upper half over it. Then draw the lettering or monogram on the upper half which will now have printed on the lower half. Take the carbon copy of tissue and place it, face against the article to be engraved rubbing over the back of the tissue paper with rubber marker and the design will appear in the reverse on whitened surface ready for engraving. Where design is not wanted reverse, you can first draw the design on a piece of tissue paper, shaping it up carefully; place the drawn-up design against a sheet of carbon with the carbon side against the whitened surface of the article and trace it off in the reverse. The work of engraving, in either instance, can then proceed.

Round gravers are best for seal cutting, Nos. 50, 51, 52, 53, 54 and 55 being especially suitable. Sharpen only the face of the graver for block and old English letters. The narrower tools are used for smaller size letters. Keep going over the cutting until the desired depth is secured, which, of course, is dependent upon the thickness of the metal being cut.

Script lettering is handled as above but a square graver is to be used as well as round graver. Monograms are also handled similarly.

To determine the result of the cutting, fill in cutting with a little magnesia and take an impression of it in wax. This will show not only the design but the depth of the cutting and will suggest where touching up, if any, is necessary.

ENGRAVING PEARL GOODS

White the pearl with Chinese white quite thickly. Draw in the lettering or design with a soft lead pencil. Do the cutting with a square graver. If block or Old English lettering is used, a flat graver is the suitable tool, as on silver or gold metals. See that edges are cut clearly and evenly. To bring out the design for examination, fill in with any colored crayon.

ENGRAVING UMBRELLA HANDLES OF WOOD

The engraving is done as on metal, but particular care must be taken to avoid tearing the wood. Some woods are easily engraved; this is true of boxwood, which can be handled like metal. In all instances, the graver must be sharp. Do not use too much pressure on graver. Engraved wood handles can be filled in with colors, which give a very pleasing effect.

Styles of Engraving for the Jewelry Trade

Price List Upon Request



All orders receive prompt attention

**DESIGNING OF DOUBLE LINE CIPHERS AND BLOCK AND ROMAN MONOGRAMS
IN GOLD, GOLD FILLED, SILVER, ETC.**

Demonstration

1, the metal; 2, making the design; 3, outlining the letters or monograms; 4, sawing out of the letters of monograms; 5, soldering on the pins, bars or catches; 6, polishing, plating or satin finishing of the monograms; 7, engraving of same.



Closeline Leaf Cypher L. R. C.



Closeline Leaf Cypher E. W.

Monogram Fobs, Belt Buckles and Ladies' Hand Bags, Wrist Bracelets, Neck Fobs, Vest Fobs, Etc.

THE METAL

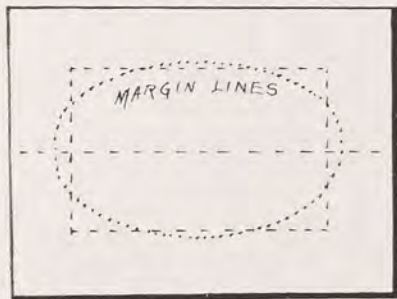


FIG 1. IN SILVER
GOLD OR GOLD FILLED.

ROUGH SKETCH

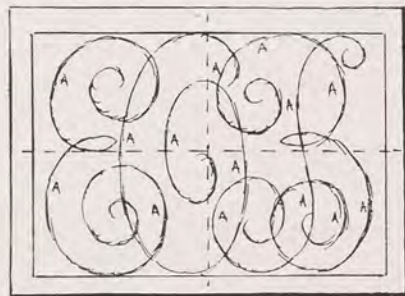


FIG 2. THE DESIGN

DOUBLE LINED

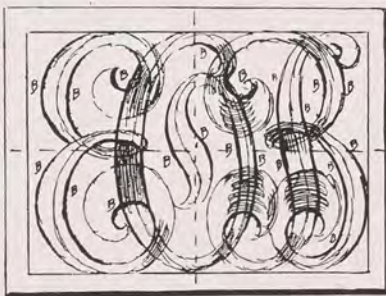


FIG 3- READY FOR OUT LINE

FIG 4.
READY
FOR
SAWING
OUT

OUT LINED
ENGRAVED



FIG 4 SMALL HOLES DRILLED

Light lines ARE the (A) lines to be drawn FIRST.
BLACK lines 2nd SEE PAGE Double line Ciphers.

WIDER FRAMES MAY BE USED AS SHOWN IN ABOVE, FIG. 1.
IN SQUARES OR OVALS.



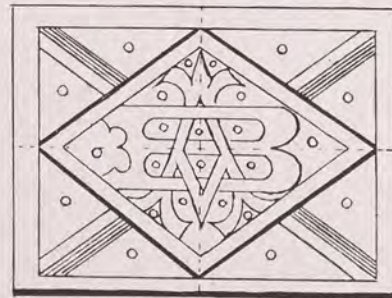
O.E. S. LEAF STYLE 1915.



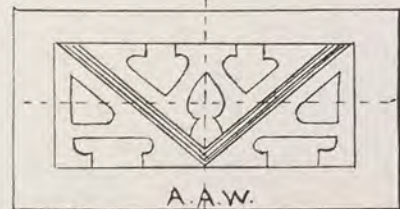
A.B.C. IN OLD ENGLISH



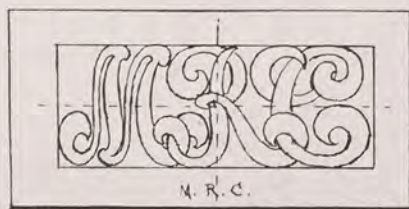
M.D.K. IN JAPANESE



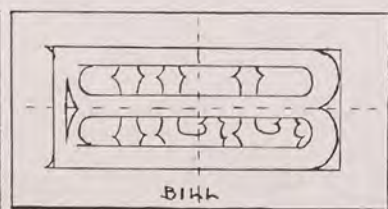
A.B. IN ROMAN-BLOCK



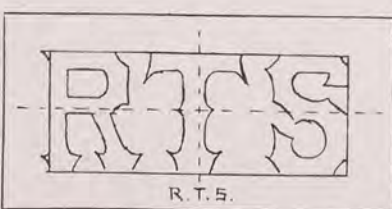
A.A.W.



A.R.C.



B.H.L.



R.T.S.

TABLE OF EXPLANATORY RULES FOR MONOGRAMS

Following pages: 67, 68, 69, 70 and 71.

Page 67

Line A Looping the loops of 2 X letters.

" B Looping the halfover letter over the X letter.

" C Looping the loops of 2 halfover letters.

" D Looping the over letter over the X letter.

Page 68

Line E Looping the loops of 3 X letters.

" F Looping the halfover letter over 2 X letters.

" G Looping the loops of 3 halfover letters.

" H Looping the over letter with 2 X letters.

Page 69

Line I Looping the 2 X letters with the over letter.

" J Looping the 2 X letters and the over letter.
(Same letters)

" K Looping 3 diamond letters, also 1 diamond letter with 1 X letter and 1 halfover letter.

" L Looping the halfover letter with the diamond and X letter.

2 letter combinations in X letters.

2 letter combinations in 1 X and 1 halfover letter, to the left and to right.

2 letter combinations in 2 halfover letters—left and right, which are the L and S loops.

2 letter combinations in 1 over letter over the 1 X letter.

3 letter combinations in 3 X letters.

3 letter combinations in 2 X letters and 1 halfover letter to the right and to the left, which are the L and S letters.

3 letter combinations in halfover letters.

3 letter combinations in 1 over letter with 2 X letters to the left.

3 letter combinations in 2 X letters and over letter, placing the over letter over the X letter to the right.

3 letter combinations in 2 X letters and over letter, individually of the same initials combined.

3 letter combinations in 1 diamond, 1 X and 1 halfover letter to the right.

3 letter combinations in one halfover letter, 1 diamond and 1 X letter, placing the halfover letter to the left.

3 letter combinations in 1 X letter, 1 diamond and 1 over letter, placing the over letter to the right.

TABLE OF EXPLANATORY RULES FOR MONOGRAMS

Page 70

Line M Looping the circle or over letters.

“ N Looping the loops of X letter and diamond letter with X letter.

“ O Looping the loops of three halfover letters.

“ P Looping the loops of the diamond halfover and diamond letter.

Page 66

Line Q Demonstrating the 9 X letters.

“ R Demonstrating the 5 circle or over letters.

“ S Demonstrating the 10 halfover letters.

“ T Demonstrating the 2 diamond letters and figures in similar manner.

Method in changing any one of the 2 or 3 letter combinations to any other letter by means of the dotted lines, as shown on charts. By leaving off a loop or adding a loop on any one letter, it makes the change as shown in demonstration of the 96 monograms. The small signs below the monograms indicate the change of letters.

3 letter combinations in three circle or over letters.

3 letter combinations in 2 X letters with the diamond letter in center to left and the diamond in center to the right of the 2 circle letters.

3 letter combinations in 2 halfover letters, with the diamond letter in the center.

3 letter combinations in 2 diamond letters with the halfover letter in the center and the 2 X letters with the diamond letter to the left.

Rule.—Any one of the 5 over letters are placed over any one of the 9 X letters, as shown on page No. 65, which are designated by one or two more stems close together by their signs X.

Any one of the 10 halfover letters, meaning the loops, are looped over the X letters, as shown on page No. 65, to right or left.

The I or J letter, called the diamond letter on account of being slim and long, are placed in positions as shown, only, the loops interlacing with other letters.

The sign ring around the X indicates that an over letter goes over the X letter. Thus: X??

THE FUNDAMENTAL PRINCIPLES TO BUILD ON

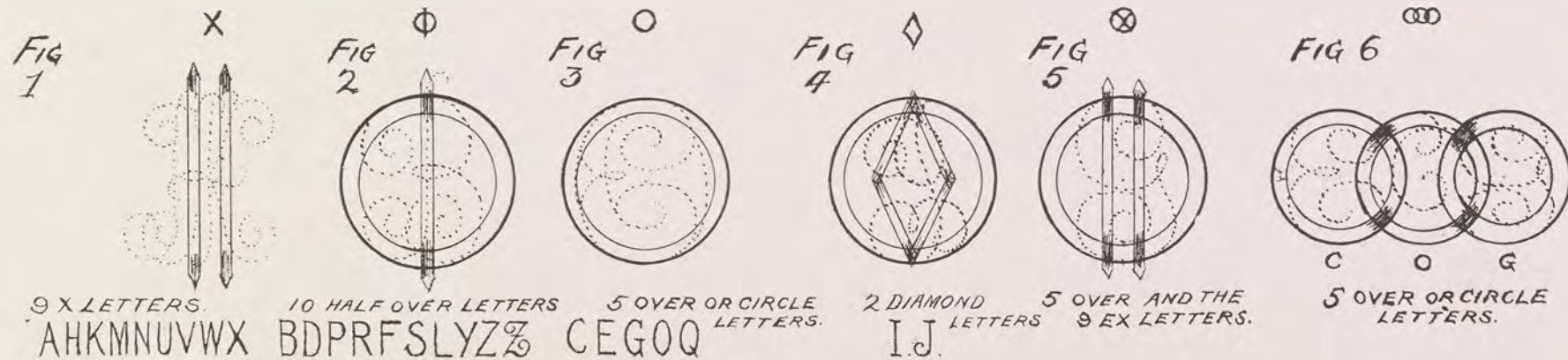
These are the first principles of laying out of any Cipher Monogram in either single line, double line, plain or fancy leaf or ribbon and ribbon leaf monogram. Speed in designing and engraving can only be obtained through accuracy, slow and careful learning—not how much is done, but a little and well done.

Good results can only be obtained by a few hours' daily practice, for several months—and then constantly keeping after it.

Form a habit and make it a point to do it. That's what counts. The art of designing is only mastered by accuracy in making it a point to design as lightly as a feather. You must form a habit and make it a point to design lightly, only using pressure when necessary to make the drawing heavily, when detail and accurate work is wanted.

An easy method, which will give the beginner, or advanced engraver a clearer and better understanding and a greater knowledge of monogramming and other lettering. Our method is the best known up to the present time, and is being eagerly sought by thousands wishing to learn how to balance, space, get graceful curves, loops and ovals, and having loops touch at all points. We can give but a few pointers here. Earnest practice is, of course, necessary. It often occurs that there are too many loops and the engraver does not know where to place the loops. The thing to do is to leave off the lower loop, either right or left, on all the following X letters such as A, H, K, M, N, U, X, and the upper right hand loops of such X letters as H, K, N, V, W. Only one loop of the letter U can be omitted. Either loop may be omitted on the letter X right or left. No loops can be omitted on any over letters, and the following loops may be omitted on such halfover letters as B, R, Z, either right or left hand lower loop only.

Following upper loops of halfover letters as the left loop of the S or Y, on the diamond letters either loop may be left off above. This rule does not apply to figures. Good judgment must be used by the engraver when designing monograms. Monograms must be designed so that they can be easily read, filling out the oval, circle or squares and above all, no beauty lines or shades are allowed to be crossed, and care must be taken not to run shades together.



Demonstration of the Sign or Code, Used by the Famous Winter System in Designing Single and Double Line Ciphers and Ribbon Monograms

Explanation. Fig. 1 sign indicates any of the 9 X letters, meaning the 2 vertical bars or stems of any of the 9 X letters.

Fig. 2 sign indicates any of the 10 halfover letters, meaning the bar through the center of circle, which means that the upper loops and lower loops, left or right, are placed over the bars of the 9 X letters.

Fig. 3 sign indicates the circle or over letter, meaning that the upper and lower loops are placed over any of the 9 X letters. Shades to the left and right, which is demonstrated in Fig. 5.

Fig. 4 sign indicates the diamond letters, meaning a long and slim letter, which can only be placed alongside of any of the letters and interlacing only the loops.

Fig. 5 sign indicates the over X letter, meaning that any of the 5 over letters are to be placed over any of the 9 X letters.

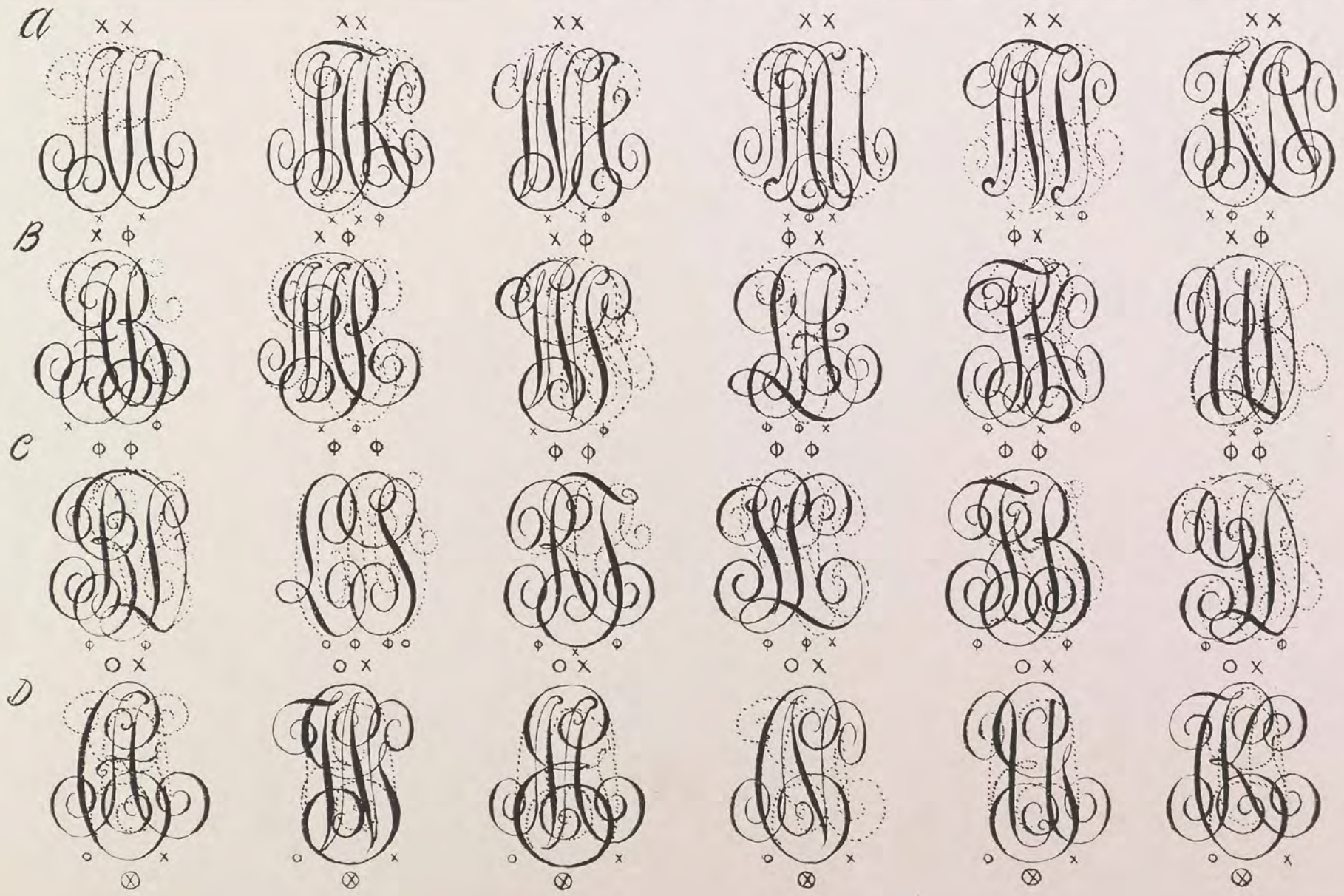
Note.—The over letters E or G should not be placed over the X letter K on account of its bow-like appearance.

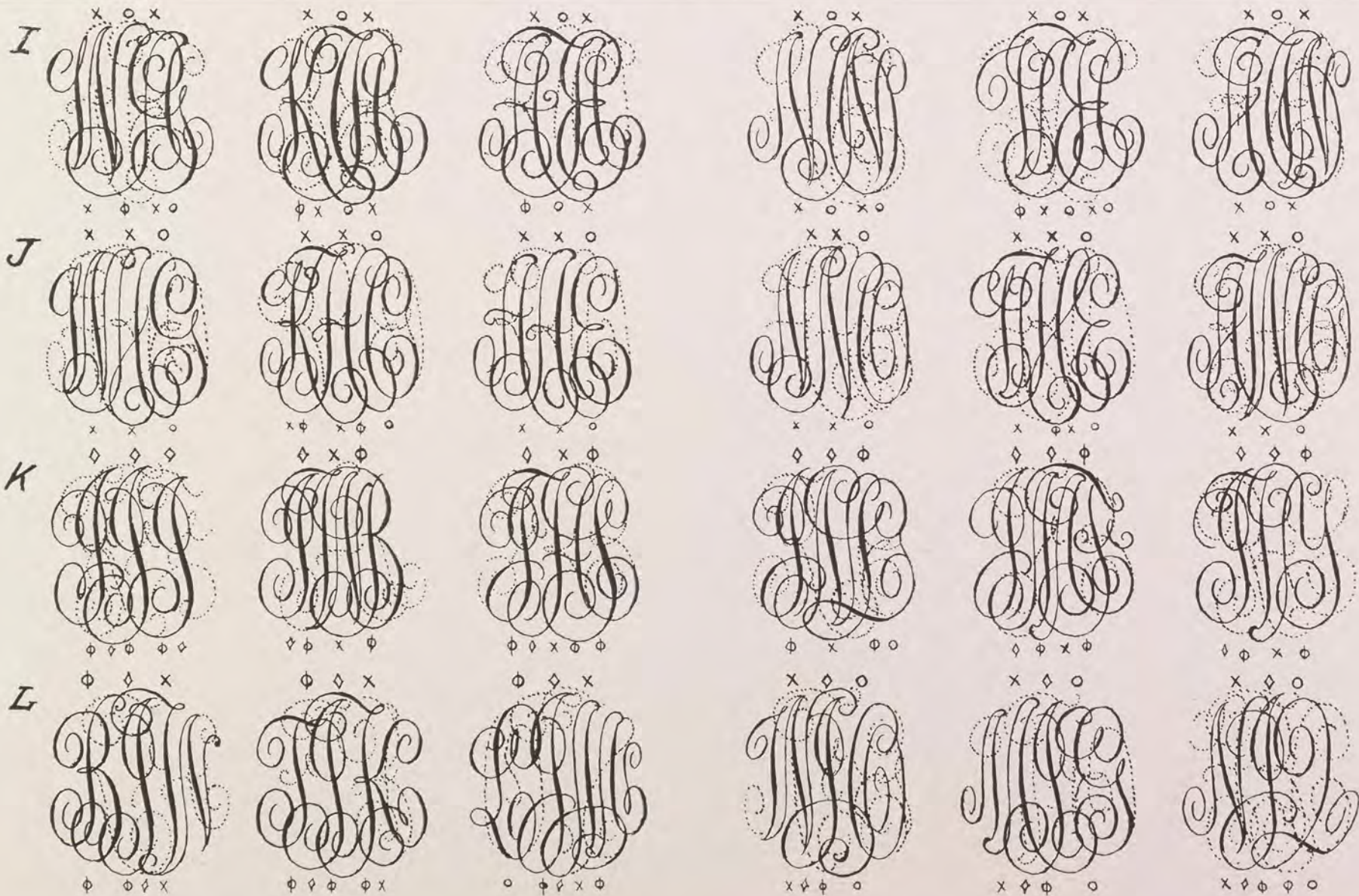
Note.—This style of capital letter Q can also be used in monograms, which at times makes a better combination.

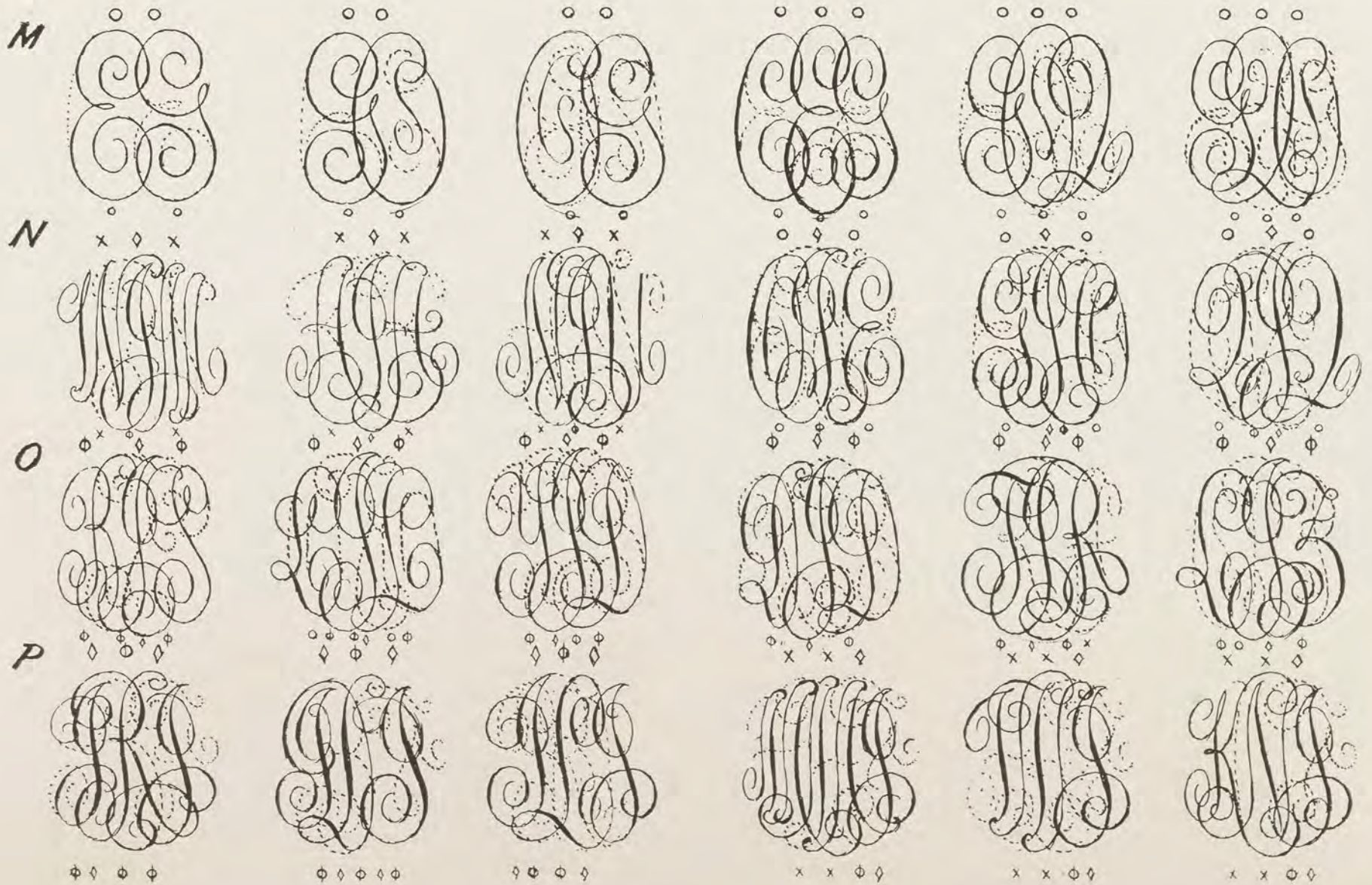
Fig. 6 sign indicates that any of the 5 over or circle letters are to be interlaced or looped one into the other, like 3 links, as demonstrated

Arrows show and indicate motion in designing of monograms, following numbers in rotation.









MEANING OF TERMS AND SIGNS USED IN ENGRAVING

Srpt. stands for Script.

Blk. stands for Block.

O. E. stands for Old English.

Mono. stands for Monogram.

Lett's stands for Letters.

Rib'n Mono. stands for Ribbon Monogram.

Closetline, meaning lines close together.

Zero-Cipher, meaning cipher monogram.

Drop Mono., meaning one letter below the other.

Diagonal Drop on an angle of any degree hanging from the upper left to the lower right-hand curves.

Closetline leaf monogram formed by a combination of closetlines, with leaves placed on the stems and scrolls.

Double line cipher monogram formed by a combination of two lines.

Ribbon leaf, a combination of ribbon filling with leaves, placed on stems and scrolls.

Leaf cipher formed by a combination of two lines with leaves.

Japanese, characterizing the Japanese style of lettering.

Solid cut indicates bright or shade cut; meaning with one cut of the graver.

Hairlines, meaning fine, light line cuts.

Ribbon filling, meaning space between lines; gradually opening and closing of lines.

Arrows show and indicate motion in designing of monograms.

Double cut, meaning two tapered cuts placed together as shown on chart, page 9, Figs. 2-6.

Running Script means on a 45-degree angle.

Connected Letters mean linked together upright or slanting.

Signs to observe in Script, Block, Old English and monograms.

The letter M on the line is to meet the cutting, as per demonstration of charts.

The letter X on the line is to cut both ways, as per demonstration of charts.

Arrows indicate the direction of cutting any line.

Small x at the loops of any letter or monograms is to start from.

Guide lines are to guide the graver when cutting, also for designing lettering, which is important and ought to be observed at all times.

SOME TIME SAVING METHODS OF LAYING OUT WORK

Using magnesia powder over Chinese white in designing to prevent the necessity of rubbing out the design of inscription or monogram, before corrections or additions can be made. After the Chinese white is dry and the design has been drawn in and it then becomes desirable to make an alteration, just lightly rub a little powdered magnesia over the design which will be brought out delicately yet distinctly in white. Any change can then be made. Magnesia may be had at any drug store, in cake form.

Another method is to moisten a piece of soap, or use a little grease, rub the finger over the soap or grease and then over the article and then make your design. For alterations the above method is used in the same manner.

How to line up lettering that is to be engraved horizontally on Loving Cups, Tea Sets, Napkin Rings, Baby Cups, Flat Rings, Oval Rings and Bracelets.

The method as shown in the charts herewith, on Page No. 76 is the most practical and successful known. It saves time and trouble, it is simplicity itself. Here as follows: take a rubber marker and hold it securely in the engraving block; then turn the article that is to be lined for lettering around the marker. For inside lining of Rings and Bracelets, use marker, holding it with thumb and index finger as shown in chart, Page No. 74. Dividers can also be used to good advantage. For the above smaller articles use same method, holding marker on a block of wood of desired height.

Engraving of Larger Articles. In handling a Loving Cup while engraving, place it in a box packed with tissue paper or soft cloth; lay the cup or similar articles therein, which will not mar or scratch while being turned about.



Correct Way of Taking Out Pin Before Engraving



Replacing Pin After Engraving



Finding Center of Watch Cases, Also Locket



Drawing Lines Outside of Rings, Bracelets, Etc.



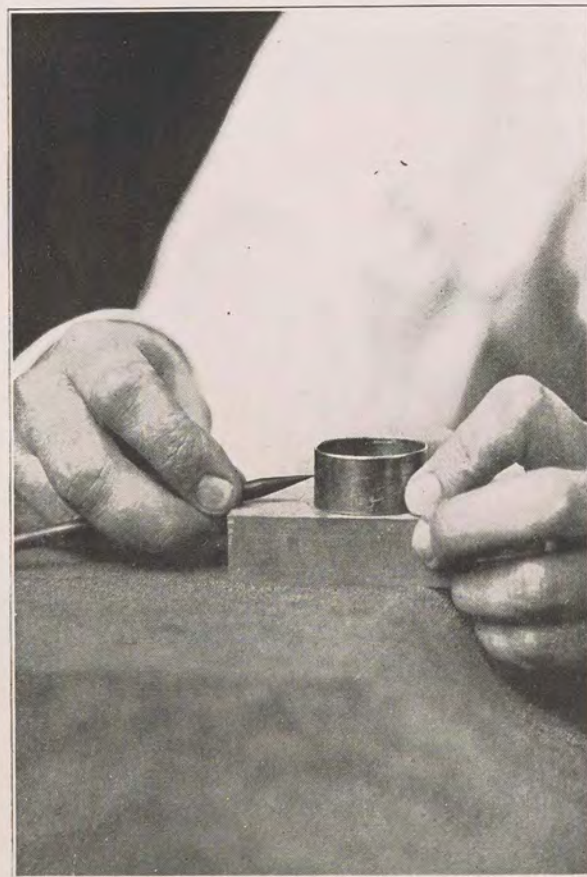
Drawing Lines Inside of Rings with Rubber
Marker



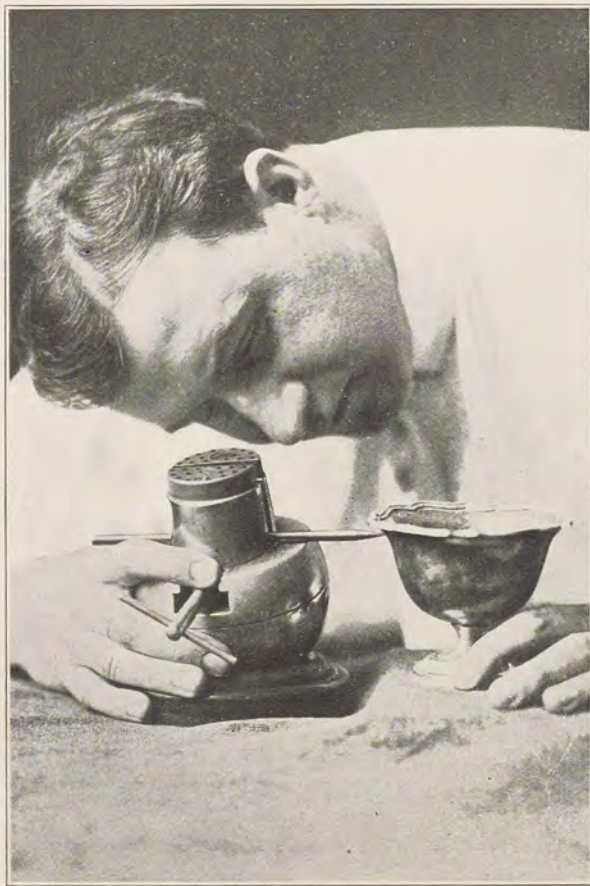
Correct Way of Holding Any Ring Between Two
Strips of Lead, for Outside Ring Engraving



Drawing Lines on Inside of Napkin Rings, Using Small Piece of Rubber Instead of Lead in Dividers



Placing Rubber Marker to Draw Lines for Napkin Rings and Bracelets



Drawing Lines on Bowls, Tea Sets, Vases, Etc.



Method Used in Drawing Lines for Inscription Work
for Loving Cups, Etc., Using Rubber Marker
to Keep from Scratching



Drawing Lines on Baby Cups, Etc.

**PORTRAIT DESIGNING AND ENGRAVING
FOR GOLD LOCKETS AND INSIDE OF WATCH CAPS**

H. F. BARNARD CO.
JEWELERS

WATCH ENGRAVERS C. & G. L. A. C. BY.

100 BARKER STREET

MUSCATINE, IOWA. Jan 26 1906

Winter Engraving Co.
Chicago Ill.

Gentlemen:

Replying to your favor of recent date regarding the locket you engraved for us will say that it was entirely satisfactory and we think the engraving fine we hardly expected it to look just like the photo and were very much pleased to find it such a perfect likeness. Our Customer was highly pleased with it. Will send you Chicago exchange draft the 1st

Very truly yours
H. F. Barnard Co



All persons desiring this work done will please write to Mr. Winter. He will give all work his personal attention.

Expert work and reasonable prices. Satisfaction guaranteed.

Mr. Albert A. Winter is qualified to teach the art of designing and portrait engraving, having given this art years of study. In enrolling with the Winter School of Engraving, you have the assurance that you will receive a thorough course in all that makes for first-class work. Mr. Winter has had practical experience and therefore is enabled to demonstrate in a way easily understood by his pupils. Both men and women are taught. The course requires two years' study, and the tuition is very reasonable, considering Mr. Winter's wide reputation as a fine artist and teacher. The tuition is \$350.



The cut shown here was designed and engraved by Mr. Winter for H. F. Barnard Co., of Muscatine, Iowa. The locket being of solid gold, was engraved with a monogram on the reverse side.

Read the testimonial, which speaks for itself.

Watches, locket, etc., to be used for presentations by private trade or by jewelers, will be done at a lower cost and in less time required elsewhere.

TABLE OF CONTENTS

Winter's Booster, Book as Good as a School.....	1	Inscriptions, Designing and Engraving, Watch Caps, etc.....	26
Winter's School of Engraving. By Men Who Know.....	3	Inscriptions, Continued—Bright Cutting on Soft White Metal Goods	27
Preface	4	Designing of Script, Monograms A, B to K, L.....	28
Purpose of The Book.....	5	Designing of Script, Monograms M, N to W, X.....	29
General Instructions and Form.....	6	Designing of Script, Figures 1, 2 to 90, Y, Z.....	30
Correct Methods Used in Designing Script, Block and Old English Lettering—Form and Habit.....	7	Plain Closeline Stems for Closeline Monograms A, B, C to M, N, O	31
First Lesson, Practice Exercises.....	8	The Alphabet Continued, P, Q, R to Monogram Date, 1915 Placing the Leaves.....	32
Studies in Script, Fundamental Knowledge, Designing Methods.....	9	The Alphabet Continued, P, Q, R to Monogram Date, 1915 to 1917	33
Display Cut—Script Alphabet Demonstrated.....	10	Closeline Leaf Stems, for Closeline Leaf Monograms.....	34
Key to All Letters, Script Alphabet.....	11	Monogram Stems for Closeline Leaf Monograms. How to Make and Build Monograms.....	35
Standard Script Lettering.....	12	Closeline Leaf Monograms, Designed and Engraved.....	36
Designing of Block and Old English Lettering.....	13	Running and Vertical Linked Script and Drop Monograms....	36
Designing and Engraving Difficult to Beginners.....	14	Display Plate of Various Lettering of Script, Block and Old Eng- lish. Plain and Fancy Monograms.....	37
Block Lettering, Various Styles.....	15	Designing and Engraving of Drop Monograms.....	38
Block, Continued.....	16	Designing of Double Line Cipher Monograms.....	39
Large Block Lettering	17	Designing of Double Line Ribbon and Ribbon Leaf Monograms.....	40
Old English, Display Plate No. 1.....	18	Designing and Engraving of Double Line Ribbon and Cipher Monograms	41
Old English, Continued, Display Plate No. 2.....	19	Display Plate of Various Lettering in Leaf, Cipher and Orna- mental Roman Monogram Engraved.....	42
Old English, Continued, Display Plate No. 3.....	20	Method Used in Designing of Block and Roman Monograms....	43
Old English, Continued, Designing and Engraving of Letters..	21	Designing of Block and Roman Monograms, Continued.....	44
Engraving Chafing Dishes, Plated Ware and Hard and Soft White Metals	22	Outlining and Filling in, of Block and Roman Monograms.....	45
Method Used in Designing Double Line Old English and En- graving	23	Display Plate, Fancy Roman, Monogram A, B, E, Engraved....	46
Designing of Fancy Names in Script, Block, and Old English in Leaf Style.....	24	Effects in Engraving.....	46
Engraving Spoon Bowls, Plain, Fancy Script, Block, and Old English Lettering	25		

TABLE OF CONTENTS—Continued

Studies in Diamond Monograms.....	47	Engraving of Umbrella Handles—Wood.....	58
Studies in Triangle, Square and Circle Monograms.....	48	Engraving for the Trade.....	59
Engraving of Diamond Monograms and Japanese Lettering.....	49	Monograms for Ladies' Hand Bags.....	60
Novelty Monograms, Designing and Engraving of Same.....	50	Designing, Engraving and Sawing Out of Monograms.....	61
Designing and Engraving of Watch Cases, Locketts, Signet Rings and Cuff Links.....	51	Table of Explanatory Rule for Monograms.....	62
Display Plate of Celluloid Engraving.....	52	Table of Explanatory Rule for Monograms, Continued.....	63
Method of Engraving and Filling in with Color Crayons.....	53	Fundamental Principles to Build on.....	64
Handling Silverware.....	53	Famous Winter System and Code Used in Designing of Mono- grams.....	65
Impressions of Small Articles for the Purpose of Duplication...	54	Monotype Letters for Monograms, with Their Signs by Which the Letters Are Represented.....	66
The Bright Cutting of Aluminum Ware.....	54	Display Plate 1, Showing the Method in Changing Any One of the Two or Three Letter Combinations.....	67
Polishing of Aluminum.....	54	Display Plate 2, Showing the Method in Changing Any One of the Two or Three Letter Combinations.....	68
Polishing and Cleaning of Engraving.....	54	Display Plate 3, Showing the Method in Changing Any One of the Two or Three Letter Combinations.....	69
Slipping and Fixing of Slips When Engraving, Burnishing and Finishing.....	55	Display Plate 4, Showing the Method in Changing Any One of the Two or Three Letter Combinations.....	70
Inside Ring Engraving.....	55	Terms and Signs Used in Engraving.....	71
How to Hold Various Kinds of Rings.....	55	Time Saving Methods.....	72
Graver Sharpening.....	55	Demonstrating Time Saving Methods.....	73, 74, 75, 76
Engraving of Gold and Gold Filled Watch Cases.....	56	Portrait Designing and Engraving.....	77
Engraving of Large Script on Large Articles.....	56	Table of Contents.....	78
Monogram Engraving of Polished Goods.....	57	Table of Contents.....	79
Engraving Articles of Silver.....	57	Practical Engravers' Tools.....	80, 81, 82
Engraving Inside of Dishes and Bowls.....	57		
Cake Trays, Etc.....	57		
Engraving Soft White Metal Goods in Block Letters.....	57		
Designing and Engraving Seal Stamps.....	58		
Engraving of Pearl Goods.....	58		

HIGH GRADE ENGRAVING BLOCKS, Held in Distinct Favor by Professional Engravers Everywhere

The REXCINO is a great favorite with the engravers who give preference to a light weight block, yet wish to realize the advantage of a large work-holding capacity.

THE
REXCINO
REG. U.S. PAT. OFF.

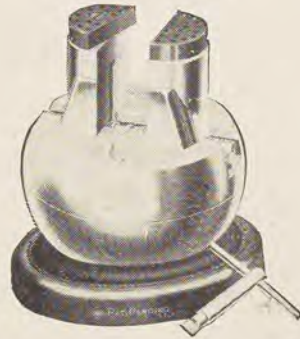


Price, complete, with Attachments, **\$15.00**

Weight, 12 pounds

Patents April 9, 1912 and April 1, 1913

THE
REX
REG. U.S. PAT. OFF.



Price, complete, with Attachments, **\$20.00**

A 20-pound Block of Unlimited Capacity

The high-grade man of the profession will find in the Rex engraving block the full value of his investment and a faithful servant to last him a lifetime.

It occupies the summit of achievement in engraving block construction.

All tools illustrated in this book can be obtained from the Winter Engraving Co., Chicago. Prices upon application.

The VICTOR represents the very best that has ever been done in a modern engraving block at a low price. It meets the requirements of the most discriminating engraver in either factory or store.

THE
VICTOR
PATENTED



Price, complete, with Attachments, **\$13.50**

Weight, 15 pounds

NECESSARY TOOLS FOR BEGINNERS' USE

"Rexcino" Engraving Block.....	\$15.00
6-inch Pad, No. 1603	1.10
India Oil Stone combination with box, No. 5026.....	.85
Chinese White, No. 157415
Rubber Marker, No. 1568.....	.10
Burnisher, No. 87535
Impression Wax.....	.25
Eye Glass, No. 1479.....	.25
Link and Spoon Holders, No. 1609..	1.25
Pin Push, No. 3983.....	.25
Pins, set of four, No. 1553.....	1.00
Sponge Glass15
Magnesia05
Oil Can.....	.05
Leads to hold Seal Rings.....	.10
Polishing Paper, 4-0, No. 1490....	.10
Ring Pad, No. 1595.....	1.10
Flat Gravers, as follows:	
No. 36.....	} Per doz. \$12.50
No. 37.....	
No. 38.....	
No. 39.....	
No. 40.....	
No. 42.....	
No. 44.....	
No. 46.....	
Black Handles, 1 1/2 dozen..	Per doz. .30
Round Graver, No. 55.....	.15
Square Gravers, Nos. 8 or 9... Each	.15
Two Patent Handles... .. Each	.25
Lining Tools..... Each	.30
Graver Sharpener, Crocker, No. 1447	3.50
Dividers for Monograms and Inscriptions, No. 120665

PRACTICAL ENGRAVERS TOOLS AS USED BY



ENGRAVERS' MARKER

FINE HAND MADE TWEEZER

PIN PUSHER

CHINESE WHITE

EYE SHADE

BRASS PRACTICE RINGS

BRASS PRACTICE RINGS

Flat.

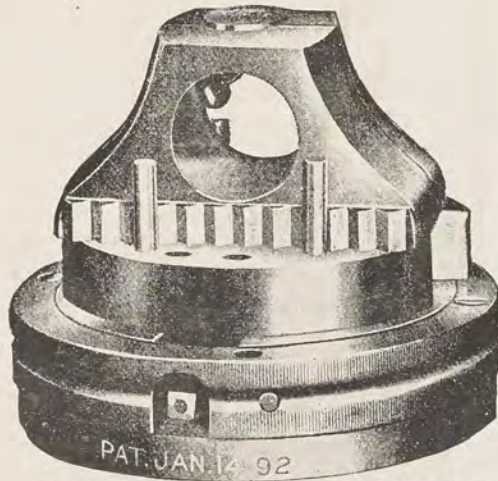
Oval.

GRAVER HANDLE--Black Japanned

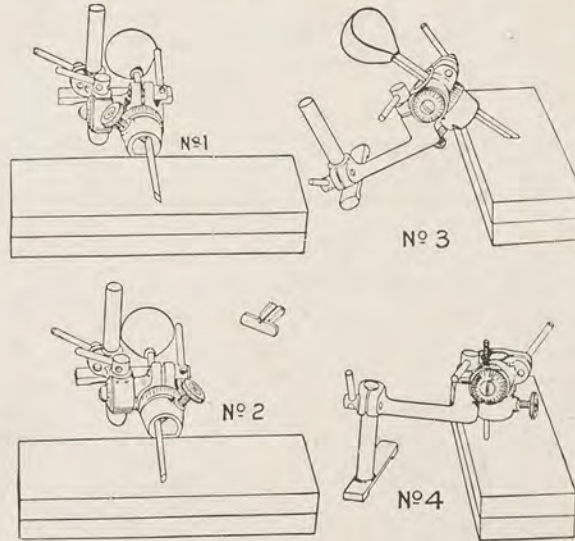
EYE GLASS WITH SPRING

LARGE SPHERICAL LAMP.

THE WINTER'S SCHOOL OF ENGRAVING, CHICAGO



CROCKER SLEEVE BUTTON HOLDER



GRAVER AND TOOL SHARPENER

These Cuts Show the Great Capacity of the Sharpener

- No. 1 shows a square graver or turning tool being faced flat.
 - No. 2 shows tool reversed to other side without losing the angle
 - No. 3 shows the tool being sharpened on top. This is accomplished by simply turning the tube over and setting it by the gauge
 - No. 4 shows method of squaring face of punch or screw driver, and is accomplished by raising body of sharpener to top of post
- The sharpener can be set by the gauge to any angle, as shown in above drawing.

No. C17. Each

.....\$3.50



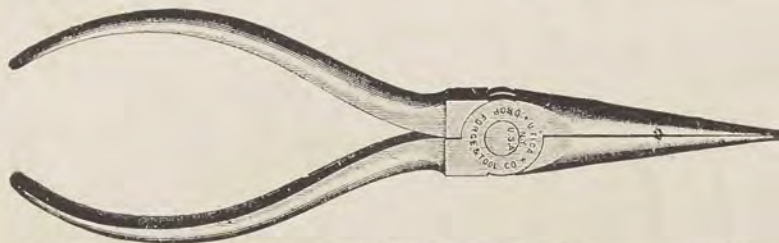
Impossible to Mar Spoon
SPOON HOLDER



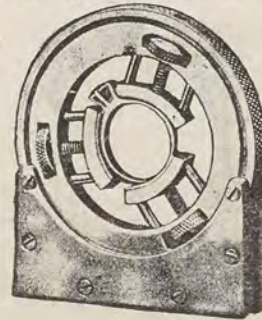
ENGRAVERS' PAD—SOLID



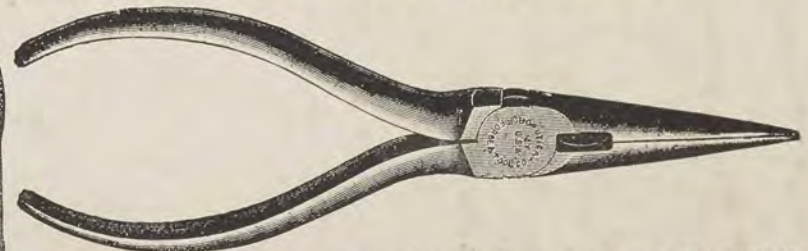
INDIA OIL STONES—6 inch



No. 2173. Long Snipe Nose Pliers, drop forged, 5½ inch\$3 70
No. 2174. 5½ inch, nickel plated..... 0 90

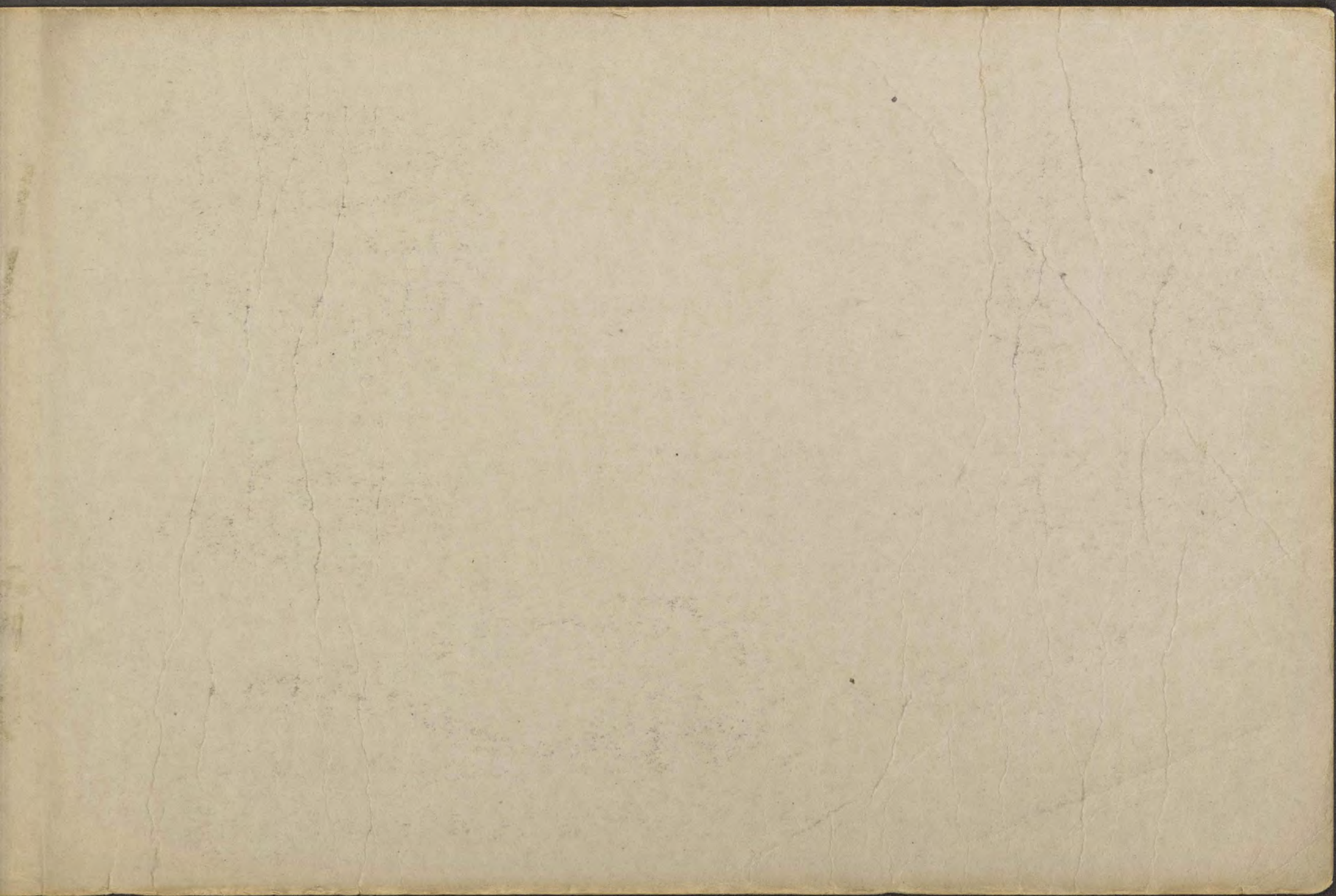


RING HOLDER



No. 2175. Long Snipe Nose and Side Cutting Pliers, drop forged 5½ inch\$ 80
No. 2176. 5½ inch, nickel plated 1 40

ORDER THROUGH YOUR JOBBER



TRADE MARK



WINTER'S BOOSTER.