



IV 1026



Digitized by the Internet Archive  
in 2016



Copyright by THE JEWELERS' CIRCULAR PUB. CO.

189 Broadway, New York.

Entered at the Post Office in N. Y. as second class matter.

VOL. XXXII.

NEW YORK, WEDNESDAY, MAY 6, 1896.

No. 14.

## SALIENT SPECIMEN OF CANADIAN SILVERWARE DESIGNING.

MONTREAL, Can., April 25.—Some time ago Captain Joseph Ritchie, commodore of the Allan steamship line, retired after 44 years of active service on the Allan vessels. Such was his popularity and so greatly was his knowledge of seamanship valued, that his retirement was made the occasion by his many Montreal friends of a presentation of a silver service and an illuminated address.

The service, which is one of the handsomest ever made in Canada, was designed and made in the establishment of Henry Birks & Sons, jewelers, Phillips Square, this city. It is in the old English style with the introduction in repoussé work of maple leaves and beaver. The handles and tops of the coffee and tea pots are of

ebony. There are seven pieces altogether: coffee pot, tea pot, sugar bowl, milk and cream basins, tray and sugar tongs.

The tray contains a wreath of maple leaves and beaver with the inscription. With the exception of the tray, all the pieces are of solid silver lined with gold. The tray is a

huge piece of solid silver with a mirror-like polish. The cabinet is a beautiful piece of work. It is of polished bird's eye maple lined inside with silk and satin of a light pea green hue.

Accompanying the service was a beautiful illuminated address to Captain Ritchie, in

## The Thomas Testimonial.

THE testimonial recently presented to Theodore Thomas, embodies in its conception a graceful and appropriate tribute to that favorite master. In the olden time the

conventional form of crown was used to signify the exalted position of one to whom honor was due, and the outline and general intention of the Thomas testimonial is, therefore, to represent a crown in the form of centre-piece, thus making it both ornamental and useful. Attributes of music, as well as other symbols, are employed in its decoration. Around the base are spaces in the shape of ornamental hearts, in which are portraits of the



SILVER SERVICE PRESENTED TO CAPT. JOSEPH RITCHIE, COMMODORE OF THE ALLAN S. S. LINE.

which his 44 years of service on the Allan steamers were eulogized in the highest degree. On the 24th inst., the service and address were sent to H. & A. Allan's office for shipment to Liverpool, where the presentation will shortly be made by Sir D. Radcliffe, the Mayor.

celebrated musicians whose fine art has been so well translated and repeated by Mr. Thomas.

A Greek ornamental lyre at intervals around the top festoons assists the whole poetical construction in forming a vessel of practical dimensions for a punch bowl.

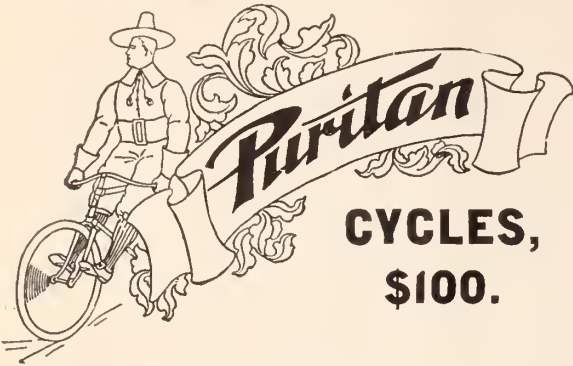

The Puritan  
...is a...  
Boston  
Wheel.

ALSO MAKERS OF  
**HECTOR**  
**BICYCLES,**  
**\$75.**

Factory Established in 1888.

It is High Grade  
Known as First Class.

WE GRANT AGENCIES ONLY TO JEWELERS.  
DISCOUNTS AND CATALOGUE ON  
APPLICATION.

The F. Kroeber Clock Co., 360 Broadway, New York.

Sole Agents for the Jewelry Trade.

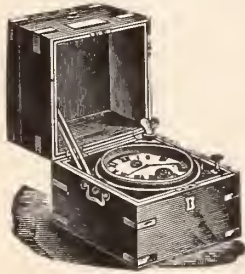

**MARINE CHRONOMETERS,**  
MANUFACTURED BY  
**John Bliss & Co., 129 Front St., New York.**

We have on hand a number of Chronometers, by various good makers, not new, which have been in service for purposes of navigation, and are excellent instruments. They have been put in perfect repair and will give satisfactory results as to performance. We will sell these Chronometers at low prices, either for cash, or on accommodating terms to suit special cases, or will hire them at moderate rates and allow the hire to apply on purchase.

SEND FOR CIRCULAR GIVING PRICE AND TERMS.

**BAND RING MOUNTING**



DESIGN  
PATENTED  
Sept. 24,  
1895.



**CHARLES KNAPP,**

MANUFACTURING JEWELER,  
41 & 43 Maiden Lane, New York.  
SPECIALTY: SUPERIOR LADIES' and CHILDREN'S RINGS



**Waverley BICYCLES.**

\$85.00

AMERICA'S FAVORITES

Are built in the largest and best equipped factory in the world.

No bicycle made stands so high in the estimation of riders and dealers. The cause is plain, **Waverleys** are built on honest value lines, and purchasers receive full value for their investment. **Waverleys** are the most popular and best selling wheels made, and dealers who are looking for a line with which they can command the bulk of the business, will serve their interests well by writing at once for catalogue and discounts.

**INDIANA BICYCLE COMPANY,**

General Office and Factory,  
Indianapolis, Ind.

Eastern Wholesale Branch,  
339 Broadway, New York City.

# Buy "The Best"

## THE "Dueber Special" BICYCLE.

MAYSVILLE, KY., April 24, 1896.

Dueber Watch Case Mfg. Co., Canton, O.

Dear Sirs: The wheel came all right, and in fact exceeds my expectations. I have ridden the different high grade wheels for twenty years, and find this the easiest running wheel I have ever been on. Yours,

JOHN BALLENGER.

CHICAGO, ILL., April 23, 1896.

Dueber Watch Works, Canton, O.

Gentlemen: After a careful and critical examination of the "Dueber Special" Bicycle, I have no hesitancy in recommending it as a first-class wheel in every respect and I consider it the best wheel I have ever seen. The extreme care bestowed upon the fitting and finish of all parts, will alone recommend it to the watch making fraternity, who as a rule, are critical in these respects. The "Dueber Special" ranks with, if it does not surpass the highest grade wheels on the market. I see no reason why it should not have an enormous sale.

Very respectfully,

GEO. K. HAZLITT.

## Fine Leather Belts,

LATEST  
STYLES.



We make a large assortment, ranging in price from \$2.00 per dozen upwards. Special sizes made to order at short notice.

Send for Descriptive  
List  
and Samples.

C. F. RUMPP & SONS, MANUFACTURERS OF

Fine Leather Goods, Fifth and Cherry Street's, Philadelphia.  
New York Salesroom, 402 Cable Building, 621 Broadway.



## A 1 MUSLIN BUFFS.

Sample sent prepaid on request.

BE SURE to give size of buff and center hole.

WILLIAMSVILLE MFG. CO.,

18 South Water St., PROVIDENCE, R. I.

MILLS: WILLIAMSVILLE, KILLINGLY, CONN



# Standard Sterling Silver Goods.



## Belts,

LEATHER, GILT,  
SILVER AND  
SILK WEBBING.

## Waist Sets,

Sleeve Links,

Hat Pins,

IN

Sterling Silver

AND

Rolled Gold Plate.

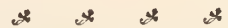

600 Useful Articles

IN

Sterling Silver.



# Foster & Bailey,

Providence, R. I.

NEW YORK,  
SAMPLES ONLY.

CHICAGO,  
SAMPLES ONLY.

### The Industrial Arts. \*

AFTER having followed the development of painting and architecture through its different stages, it is reasonable to expect that a succession of analogous events might be encountered in America during the same period, in the industrial arts. In this one will be deceived.

Painting is an abstract art which requires for its success principally a creative mind. This mind may bound forward spontaneously, in advance of the culture of the time, without being impelled by any external force. The decorative arts, however, awaken only under the pressure of a need already existing in a propitious surrounding. The task of the artist is limited to incorporating the hauntings of his imagination, while the art of the decorator must adapt itself to the tastes and customs of others. As regards architecture, which complies equally with the needs of a general order, it has nevertheless been able to expand in advance of artistic tendencies, but architecture was at first applied only to public monuments, churches or municipal edifices belonging to communities.

It will, therefore, be easily understood that from the first, American painters have been able to represent in picture the celebrated men of their young country, or portray beloved scenes in nature—rare works gathered with religious care by a very small circle of devotees—and it is self-evident that many cities raised monuments long in advance of the time when the people learned to regard the interior of their houses as anything else than

\*—Abstract from "La Culture Artistique en Amerique," by S. Bing; translated especially for THE JEWELERS' CIRCULAR from copy forwarded by the Director of the Beaux Arts, Paris, France.

the simple retreats for their families, pacific abodes after the turmoils of the day.

Later, when the desire for luxury rendered these primitive customs of domestic life more complicated, the result was no longer the expression of a natural instinct; even less was it the manifestation of a sudden vision of the beautiful; the privilege of wealth brought with it the lively desire to use it for the satisfaction of vanity. At first there was an absolute triumph of bad taste, and as the country did not yet produce anything, Europe saw a splendid opportunity for sending across the ocean shiploads of trumpery wares, imitations of things of which even the originals represented the worst epoch of our declining century. But, however insignificant might appear the commencement of this movement, however unlucky might be the first steps in this new path, the first ideas in the establishment of ornamental art had been germinated, and the time was not far distant when these germs were to form a purer taste.

This propitious time, however, was very slow in coming. While waiting for it people confided themselves to the ability of French merchants, whose branch houses multiplied each year in certain quarters of New York. This was an earnest advance toward progress, and already it was not a rare occurrence to find in certain wealthy dwellings *salons* which might contend with the low-grade elegance of a number of *salons* in Paris. It was, however, not so much in the furniture nor in the larger decorations that the first signs of an independent taste might be looked for, but they were noticeable in the domain of small articles of luxury, some of which encroached upon French ground.

Of the amateurs who take an interest in all arts without distinction, many have certainly

not forgotten the surprise caused at the Grand Exposition of 1878 by certain American pieces of goldsmithing of an artistic and daring *cachet*. It was not that they possessed the rare merit of conceptions purely original; for their decorative details were directly copied from the Japanese; but all the borrowed features were so ingeniously transposed in their new adaptation that the pieces were equivalent to original conceptions. Viewed from all sides the eye was charmed, as the features did not represent the constant reincarnation of our customary forms, the interest in which, charming though they may be, finally pall on the taste.

This sudden manifestation was due to the artistic instinct of a man whom America should ever keep in grateful memory: E. C. Moore, chief of the designing department of the celebrated firm of Tiffany & Co., who was one of the first to recognize the value of the art treasures from the ancient countries of the East, whose resources he resolved to promptly adapt. Moore collected everything which to him appeared suggestive among the decorative arts of Arabia, Persia and India, China and Japan. This collection, the only one of its kind, is at present in the Metropolitan Museum of Art of New York, to which Moore bequeathed it. Enameled glass and ancient ceramics, tissues, brocades and embossed leather, objects of bronze and hammered iron, engravings and aquarelles, sculptures of wood and ivory, works of lacquer and willowware—everything, down to the most humble thing, furnished to him food for thought, suggested to him fertile ideas. Death prevented Mr. Moore from pushing to decisive results the work undertaken. But a small cohort of young enthusiasts has already formed to continue the interrupted attempts of practically applying the art ideas presented, under many new forms.

# Dorflinger's American Cut Glass.



## SALAD BOWLS

ARE NOW IN  
SEASON.

WE HAVE STOCK  
FOR IMMEDIATE  
DELIVERY.

**C. Dorflinger & Sons,**  
36 MURRAY STREET,  
915 BROADWAY,  
NEW YORK.



# FASHION'S DECREE

Is that **LEATHER BELTS** and **SHIRT WAIST SETS** will be the proper thing for 1896. If you wish to be in it, send for samples and circulars.

## A NOVELTY FOR BICYCLISTS.

BELT AND POCKET BOOK COMBINED, WITH PLACE IN BACK TO HOLD HANDKERCHIEF.

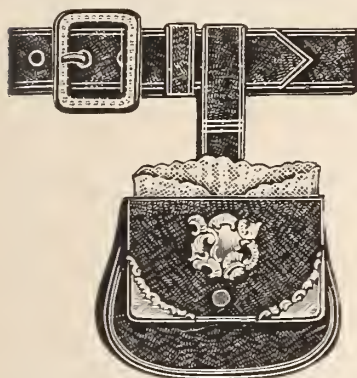

159. SEAL (1 inch belt), Complete... \$1.50  
Made also in Genuine Morocco and Calf, at from \$1.62 to \$2.12 each.

ALL GOODS GENUINE LEATHER, MOUNTED IN STERLING SILVER, GUARANTEED 925-1000 FINE



167, MOROCCO; 171, CALF, all assorted colors; 173, WHITE KID; all 1 inch widths.....\$12 00 Doz.

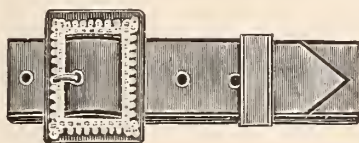

165. SEAL; 163, MOROCCO; 170, CALF, all assorted colors; 181, WHITE KID; all 1 1/2 inch widths.....\$15.00 Doz

*THE DIFFICULTY AT LAST OVER-COME.—Our Patent Belt Pin, when attached to the leather belt, makes it impossible for the skirt to slip or become disarranged.*

STERLING SILVER WAIST SETS—GUARANTEED .925 FINE.  
\$3.50 PER DOZ.—12 DIFFERENT STYLES AT THIS PRICE.

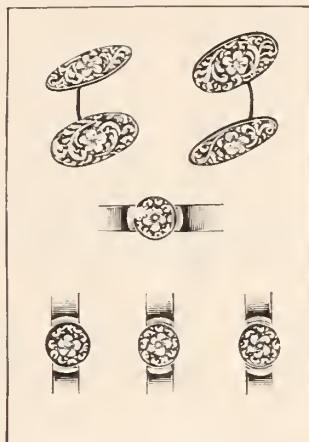

Cut 1/2 actual size.

This is undoubtedly the best article in the market for the money. Every button has an extra piece of silver soldered on the rim, so as to add to its style finish and durability, and is not a mere shell like most of the low priced waist sets on the market. We also have these goods in extra heavy, bright cut, chased patterns, at \$4.50 per dozen, and in silver, enameled, with or without Roman finish from \$7.50 to \$15.00 per dozen.

**S. C. POWELL, STERLING SILVER NOVELTIES, 51-53 Maiden Lane, New York.**

**H. M. RICH & CO.,**  
Jewelry - Auctioneers,  
21 School Street,  
BOSTON, MASS.



**The STATIONERS' ENGRAVING CO.,**  
98 TO 102 NASSAU STREET, NEW YORK.

MAKERS OF  
WEDDING INVITATIONS, RECEPTION AND VISITING CARDS

of the Best Quality, which are offered to Jewelers of recognized standing only.

Trade Mark 'SILVER WHITE,' registered.

# THE PRACTICAL ELECTROPLATOR

is the most comprehensive treatise on electroplating. 300 pages, fully illustrated, securely bound. Price \$10.00.

FOR SALE BY  
**THE JEWELERS' CIRCULAR PUB. CO.** 189 Broadway, N. Y.

# CARBORUNDUM

THE GREATEST ABRASIVE YET DISCOVERED.

Four times the Labor and Expense-saving qualities of Emery, Corundum or other abrasives. Adapted for Lapidary Work, Grinding, Polishing and every operation where a perfect abrasive is necessary.

## Price List of Carborundum Wheels.

ACHESON'S PATENT, February 28th, 1893; February 26th, 1895.

DIAM. IN.	THICKNESS IN INCHES.																MAX. REV.
	1/4	3/8	1/2	5/8	3/4	1	1 1/4	1 1/2	1 3/4	2	2 1/4	2 1/2	2 3/4	3	3 1/2	4	
1	\$.15	\$.15	\$.20	\$.20	\$.20	\$.25	\$.30	\$.30	\$.35	\$.40	\$.40	\$.45	\$.50	\$.50	\$.60	\$.70	15000
1 1/2	.20	.25	.25	.25	.30	.30	.35	.40	.40	.45	.50	.55	.55	.60	.70	.75	14000
2	.20	.30	.30	.30	.35	.40	.45	.50	.55	.60	.60	.65	.70	.75	.85	.90	11000
2 1/2	.25	.35	.40	.45	.50	.55	.65	.70	.80	.90	1.00	1.10	1.20	1.25	1.40	1.50	8500
3	.30	.45	.55	.60	.65	.75	.85	1.00	1.15	1.25	1.40	1.50	1.60	1.75	2.00	2.20	7400
3 1/2	.40	.50	.65	.70	.80	1.00	1.15	1.30	1.45	1.65	1.80	1.95	2.10	2.20	2.55	2.90	6300
4	.50	.60	.75	.85	1.00	1.20	1.40	1.60	1.80	2.00	2.20	2.40	2.60	2.80	3.20	3.60	5500
5	.70	.85	.95	1.15	1.25	1.60	1.95	2.30	2.60	3.00	3.30	3.65	3.95	4.25	4.90	5.55	4400
6	.95	1.10	1.30	1.55	1.75	2.20	2.70	3.15	3.60	4.10	4.55	5.00	5.45	5.90	6.80	7.70	3700
7	1.25	1.45	1.65	1.95	2.30	2.95	3.50	4.15	4.80	5.40	6.00	6.60	7.20	7.80	9.00	10.25	3160
8	1.50	1.70	2.00	2.40	2.80	3.60	4.40	5.20	6.00	6.75	7.55	8.30	9.10	9.90	11.45	13.00	2770
9	1.80	2.10	2.40	2.90	3.35	4.30	5.30	6.25	7.25	8.20	9.15	10.10	11.10	12.05	14.00	15.90	2460
10	2.15	2.50	2.85	3.45	4.00	5.15	6.30	7.45	8.60	9.75	10.90	12.00	13.20	14.35	16.60	18.90	2210
12	2.65	3.10	3.70	4.50	5.25	6.80	8.40	9.95	11.50	13.05	14.60	16.20	17.75	19.30	22.45	25.50	1750
14			5.05	6.05	7.00	9.00	11.00	13.00	15.00	16.95	18.95	20.95	22.95	24.90	28.90	32.80	1580
16					9.10	11.70	14.30	16.85	19.85	22.00	24.55	27.15	29.70	32.30	37.40	42.50	1380
18						11.25	14.45	17.70	21.00	24.25	27.50	30.75	34.00	37.25	40.50	53.50	1230
20							17.50	21.55	25.55	29.60	33.70	37.80	41.90	45.95	50.00	66.00	1100

The wheels are made with a vitrified bond and pressed under hydraulic pressure. Those over three inches in diameter are turned up after firing. The same numbers are used to designate the degrees of fineness, as are used with Emery, and the wheels are made in seven degrees of hardness, marked SSS, SS, S, M, H, HH, HHH, from extremely soft to extremely hard. In ordering, state diameter, thickness, hole, number and hardness.

Hones, Slabs, Files.

CUT THIS OUT.

# THE CARBORUNDUM CO.

WORKS: MONONGAHELA, PA., AND NIAGARA FALLS, N. Y.

**DIAMONDS.**  
**Wm. S. Hedges & Co.,**  
 IMPORTERS OF  
**Diamonds and Precious Stones.**  
**DIAMOND JEWELRY.**  
**170 Broadway, New York.**  
 22 Holborn Viaduct, London.

**Alfred H. Smith & Co.,**

IMPORTERS

**DIAMONDS**

AND

PRECIOUS STONES,

**182 BROADWAY, COR. JOHN STREET,**

**NEW YORK.**

Venetian Building, **34 & 36 Washington St.**

**CHICAGO, ILL.**

**Purchasers**

... OF ...

**RARE GEMS,**

PRECIOUS STONES  
 AND ALL GOODS FOR  
 JEWELRY,

ADDRESS

**R. A. KIPLING, Paris,**  
**19 Rue Drouot, France.**

**L. BONET,**

ESTABLISHED 1866.

**PRECIOUS STONES,**  
 CAMEO PORTRAITS, WORKS OF ART,  
**927 BROADWAY NEW YORK.**

**DON'T FORGET THE JEWELERS' CIRCULAR PUBLISHING CO.'S BOOK LIST when in want of any technical book in the Jewelry or Kindred Trades.**

**PAUL JEANNE,**

Manufacturer of Diamond Mountings,

**REMOVED TO** 

**36 and 38 John St., N. Y.**

**The Bowden Rings**

ARE COMPLETE IN VARIETY, CORRECT  
 IN QUALITY AND PERFECT IN FINISH.  
 WE MAKE EVERY VARIETY OF FINGER  
 RINGS 

**J. B. BOWDEN & Co.,**

**3 MAIDEN LANE,**

 **NEW YORK.**

BRANCH OFFICE :

206 KEARNY STREET  
 SAN FRANCISCO, CAL.

And all of a sudden this country, which but lately was still in its swaddling clothes, exhibited a singular power of initiative, a juvenile vigor contrasting strangely with the weakening flow of sap which has for some time appeared to threaten with anæmia the industrial arts of Europe, and to strike with impotency our most precious hereditary vocations.

What is the surprising phenomenon that can produce this inversion? We, the indefatigable educators of nations who for centuries past have not ceased sowing throughout the world the seeds of art, should not be struck by this sudden germination taking place in a far removed and uncultivated country? And is it not proper to ascertain if this significant occurrence will open our eyes to our actual weakness?

In the process of a searching inquiry of this nature, we question at once whether our decorative arts have not too long suffered by the exclusive honor paid to what we pompously name the *Great Art*. This much is certain: this question has already been answered by our artists themselves, many of whom no longer consider as unworthy of interest the productions in the industrial arts. For several years past have we seen them admitting into their public expositions with very good grace the pariahs of yesterday. Sometimes, they themselves compose plans and ingenious models of all kinds, and do not believe that they lower their genius by shaping with their hand the matter formerly reputed to be vulgar. But nothing they produce by these very sincere efforts appears to comply exactly with its purpose. It lacks the practical shape imparted to it by the mechanic, who, on the other hand, if he is an expert in his trade and thoroughly understands the organic structure of every article, too rigidly clings to patiently acquired doctrines and does not choose to depart from these lines. We have, it is true, our schools of decorative art and of industrial art. They are excellent for training an able hand to obtain all the subtlety of delicate execution. But they cannot in America become the grand academies of art; they would not know how to impel the imagination, or cause the spark of genius to be struck. What has been wanting for many years is to find the artist—artist by nature is meant—who will devote himself heart and soul to the trade of the artisan. A workman-artist is occasionally found; what is wanted is the artist-workman.

Unceasingly young enthusiasts engage in the pursuit of the ideal; but they perceive it only in its abstract manifestations, and it will remain so as long as the world shall treasure the names of those only in whom the supreme dream of the beautiful concretes into certain recognized forms. If one feels within himself the inborn gift of creative genius why should he waste it on thousands of obscure works, if by means of an inspired brush or chisel he can entertain at once the hope of a prompt apotheosis?

In America, things happen differently. Democracy, which is the foundation of the social state of the country, penetrates also the

world of art. There are no longer the hazards of birth and the choice of this or that calling does not impart aristocracy. No spirit of caste can exist where all roads lead to honors. When an American artist occupies a preferred rank in public opinion, it is not at all because he devoted himself to painting, or to sculpture; it is because his imagination instilled him with a new conception of the beautiful, and, provided that some tool was necessary to serve him in his successful struggle for renown, it matters little whether the name of the tool be brush or chisel, or anything else.

(To be continued.)

**The Bill to Incorporate the Optical Society of New York Killed.**

ALBANY, N. Y., April 29.—The bill of P. J. Andrews, incorporating the Optical Society of the State of New York failed to receive the constitutional number of votes in the Assembly to-day, and was declared lost. The vote was 65 yeas to 37 nays.

The Society has sent out to its members under date of New York, May 1, 1896, the following notice:

Dear Sir: The Executive Committee have decided upon the "Hotel Yates," Syracuse, as the place for the next stated meeting of the Society. It will be held, in accordance with the provisions of the Constitution and by-laws, on Tuesday, June 2nd, 1896, at 8 o'clock P. M., and it is expected that adjourned sessions will prolong the meeting until the following evening. The management of the hotel offer a fine assembly room, free of charge, and will make a special rate of three dollars per day for those who desire accommodations.

Owing to the central location in the State, the meeting will unquestionably be well attended, and it is hoped will mark an era of advancement for those interested in optical science. Members are requested to prepare papers to be read during the session, and to exhibit, or urge others to, any instrument or mechanism that may prove of utility or interest to opticians. The titles of such papers, and the names of instruments to be exhibited, together with the names of the authors, or inventors, should be sent to the Chairman of the Executive Committee, on or before May 19th next. A complimentary card of admission, entitling each member to one guest (who is an optician, and not already a member of the Society), is herewith enclosed. Full reports of all meetings and acts of the Society since its organization will be made in detail. The New York City delegation is expected to be large. In fact, it is believed that the meeting will be the most memorable one for opticians ever held in the United States, as the Society at the present time has an enrolled membership of over one hundred.

Respectfully,

- GEO. R. BAUSCH,  
6 East Main St., Rochester,
- W. W. BISSELL,  
101 East Main St., Rochester,
- M. E. KENNEY,  
242 Genesee St., Utica,
- E. R. MASON,  
69 Court St., Binghamton,
- A. JAY CROSS,  
20 East 23rd St., New York,
- J. J. MACKOWN,  
25 East 42nd St., New York,  
(Chairman),  
*Executive Committee.*

ESTABLISHED 1840.

**RANDEL, BAREMORE & BILLINGS,**

IMPORTERS OF

**DIAMONDS,**

AND OTHER PRECIOUS STONES.

**FINE PEARLS A SPECIALTY.**

MANUFACTURERS OF

**DIAMOND JEWELRY**

A Large Stock of Fine Mounted Goods Constantly on Hand.  
Goods Sent on Approval and Insured in Transit.

Diamonds Cut, Recut and Repaired.

58 Nassau Street,  
29 Maiden Lane,  
NEW YORK.

1 Tulp Straat,  
AMSTERDAM.

1 St. Andrew's St.,  
Holborn Circus,  
LONDON E. C.

ESTABLISHED 1841.



**CARTER, HASTINGS & HOWE,**

MANUFACTURERS OF

**GOLD JEWELRY,**

**15 MAIDEN LANE, NEW YORK.**

A. CARTER,  
C. E. HASTINGS,  
W. T. CARTER  
G. R. HOWE,  
W. T. COUGH.

FACTORY, NEWARK, N. J.

**JOHN P. CAMPBELL,**  
MANUFACTURER OF  
**WATCH CASES.**

ALL KINDS OF SPECIAL CASE WORK.  
REPAIRING A SPECIALTY.

59 Nassau St., Cor. Maiden Lane, New York.

Royal Arcanum and Maltique Ladies' Enamel Cases.

**HERMAN KOHLBUSCH, SR.**

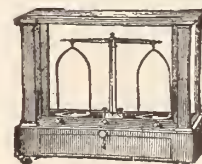

Established 1859  
Manufacturer of  
FINE BALANCES  
AND WEIGHTS for  
every purpose  
where accuracy is  
required. 59 Nassau  
Street, cor. Maiden  
La. N. Y.



Repairs (any make)  
promptly made

## Artistic Silver.

Have you seen any more truly artistic or graceful spoon patterns than our "Apollo" and "Lexington," illustrated herewith? They are made in Sterling Silver only and in a full line of all sizes, including cutlery.



J. B. & S. M. KNOWLES CO.,

PROVIDENCE, R. I.

Seen on Silver Shows Sterling.



THE APOLLO.



THE LEXINGTON.

## SLOAN & COMPANY,

SUCCEEDING

JOHN A. RILEY & SLOAN CO.,

MANUFACTURING JEWELERS,

860 BROADWAY, N. Y.

AUGUSTUS K. SLOAN, Pres.  
FRANK T. SLOAN, Vice-Pres.

BENNET OSBORN, JR., Treas.  
ALLAN A. McDONALD, Sec'y.

## AMERICAN WATCH CASE CO.,

11 JOHN STREET, NEW YORK.

Manufacturers of FINE SOLID GOLD CASES.

**A.W.C.CO**

Sold DIRECT to  
the RETAIL TRADE only.

## THE SPENCER OPTICAL INSTITUTE

THE RECOGNIZED OPTICAL SCHOOL FOR BUSINESS MEN

OUR COURSE PRACTICAL COMPREHENSIVE NONCLASSICAL IN THEORETICAL AND APPLIED OPTICS

SEND FOR APPLICATION BLANK & PROSPECTUS. CLASSES CONVEENE 1ST TUES. EACH MONTH. SPENCER OPTICAL MANUFACTURING CO. 15 MAIDEN LANE. N. Y.

OUR STUDENTS ARE THE SUCCESSFUL OPTICANS



## TOWLE MFG. CO.,

## Silversmith S,

NEWBURYPORT, MASS.

149-151 State St., Chicago, Ill.

## The Rage for Jewelry in Europe.

NECKLACES GIVEN AS WEDDING PRESENTS—  
GREAT ARTISTIC VARIETY IN RINGS FOR YOUNG LADIES—ELEGANT SILVER COVERS FOR TOILET ARTICLES.

PARIS, France, April 22.—Necklaces given as wedding presents still consist either of several rows of pearls with diamond clasps or bars holding them together at regular intervals; or of large emeralds, sapphires or rubies arranged with diamonds so as to form floral ornaments of a conventional design; but a lady of taste may become tired *à la longue* of always wearing the same style of necklace, however magnificent the stones or the pearls may be. For this reason, jewelers endeavor to introduce as much variety as possible into a line from which aristocratic prejudices seemed to have banished the slightest touch of fancy. We see here and there in the Rue de la Paix, a necklace in *joaillerie* imitating a branch of natural flowers; an Egyptian necklace showing a succession of lotus of enameled gold with a scarabæus as a pendant; a neo-Greek necklace formed of gold medallions with chased figures or portraits divided by a *grecque*; a necklace consisting of fine filigree gold introducing naïve floral motifs of cloisonné enamel; a Louis XVI. necklace, with a narrow dented band formed of a close course of diamonds, which is broken at regular intervals by a large round pearl, on each side of which is caught a jeweled garland holding a love trophy with a pear shaped pearl at the base; a necklace in a Portuguese style, consisting of pierced gold rosacæ, with rays and outlines *tourmentées*, exhibiting in the center a fine colored stone, the pendant, which is also in open work, showing the most intricate interlacing of narrow scrolls and flowerets, being very graceful, consisting of three brooch-like pieces of different sizes closely depending from one another.

Finger rings for young ladies admit of a great variety of designs; yet it is wonderful how Parisian jewelers manage, without straining for originality, to obtain so many novel effects by merely assembling in different ways tiny pearls and turquoises. Some show two white and blue wreaths overlapping each other, or a fine lozenge shaped network with a pearl and a turquoise alternating at all intersecting points. Others exhibit a Lilliputian bouquet, or a pretty little tambourine frame, or the daintiest of rosacæ. Some look like two sprigs of flowers arranged so that their stems entwined form the band of the ring. There are, besides, graceful arabesques of a quaint and naïve design showing a conventional foliage on a pierced ground encompassed within a light setting of square, oval, round, octagonal, hexagonal, or dented circular outlines; also delicate enamel work, white and blue, and imitation mosaics obtained by a close gathering of pearl and turquoise seeds. Most of these patterns, suitably enlarged, are also used for brooches, bracelets, garter clasps and shoe buckles.

Silver covers for toilet articles are adorned with sprigs of flowers chased in slight relief

and finished in varicolored gilding. A dove, standing on the cover, appears engaged in picking pearl seeds half sunk here and there in the ground. The body of all the small toilet pieces is of that peculiar fancy glass in which Gallé works wonders by skilfully introducing into the vitreous substance before it cools particles of various metallic oxides which run through it in different ways and produce all kinds of fantastic colored stains and designs. The stands are in varigilt chased silver soberly adorned with gems.

JASEUR.

**Judge Grosscup's Decision Marking the Limitations of the Copyright Law.**

The editorial which was published in THE CIRCULAR last week regarding the limitations of the copyright law, having elicited inquiry as to the law action and decision referred to, we herewith reproduce Judge Grosscup's decision in full:

J. L. Mott, Iron Work vs. Clow et al (Circuit Court, N. D., Illinois. Feb. 18, 1896. Copyright-illustrations in Trade Catalogue).

*Under Act Congress 1874, limiting the right of copyright to such cuts and prints as are connected with the fine arts, there can be no copyright on cuts contained in a trade catalogue, and not offered for copyright or to the public as works of fine art.*

In Equity. On demurrer to bill.

Suit for injunction by the J. L. Mott Iron Works against J. B. Clow & Son.

Hamline, Scott & Lord, for complainants.

Newman, Northrup & Levison, for defendants.

Grosscup, District Judge.—The bill is to enjoin infringement by defendants of complainants' copyright. The complainants, who are manufacturers of bath tubs, have issued, from time to time, advertising sheets containing a description of their porcelain baths, the dimensions and prices of the same, and such other information as people in that trade are interested in. The sheets also contain cuts or prints of such baths as are offered to the trade. The defendants engaged, among other things, in a like business, have also, from time to time, issued advertising sheets or books containing like information, and in some cases, closely copying the prints or cuts of baths contained in complainants' sheets. A comparison of the exhibits makes it pretty manifest that some of these cuts or prints of the defendants have been copied by photographic processes, or otherwise, from the complainants' cuts or prints; and it is so averred in the bill. The defendants demur to the bill, for the reason that the matter therein set forth is not, in law, a proper subject-matter of copyright.

The cuts or prints shown in complainants' sheets, in connection with their ornamental settings, may have such artistic merit as would support a copyright if offered as a work of fine art. The statutes, as amended by the act of 1874, limit the right of copyright to such cuts and prints as are connected with the fine arts. But the bill does not show that the author or designer intended or contemplated these cuts and prints as works of fine art. No copyright was asked upon them separately from the advertising sheet of which they are a part. They are not offered to the public as illustrations or works connected with the fine arts, but are adjuncts simply to a publication connected with a useful art. The court will not supply an intention that the author or designer has not avowed, or give to the cuts or prints a character and purpose different from what their surroundings indicate.

The demurrer will therefore be sustained.

## Intrinsic merit

combined with low prices, makes Cahoone's line for 1896 the most attractive ever offered to the trade.



## Cahoone's rings

this year are shown in a host of beautiful designs. Particular attention is called to the Imitation Rose Diamond and Opal Combination Rings. Sold by all leading jobbers.

GEO. H. CAHOONE & CO., Kent & Stanley Building, Providence, R. I.  
N. Y. OFFICE, 21 MAIDEN LANE.

# A New Improved Adjustable = = Eyeglass Guard.

## AN IMPROVEMENT IN EYEGLOSS GUARDS.

This is an adjustable offset guard; the guards can be lowered so the frame can be raised for distant use or raised so that the frame will be adjusted for reading, or the guards can be moved independently of each other to adapt themselves for any irregular formation of the nose. The universal acceptance and use of these guards by every optician in the country is sufficient proof of their utility.

As we deal exclusively with the wholesale trade, we would request dealers to order these guards from their nearest wholesale dealer.

For sale by all jobbers in the United States. Owned and controlled by

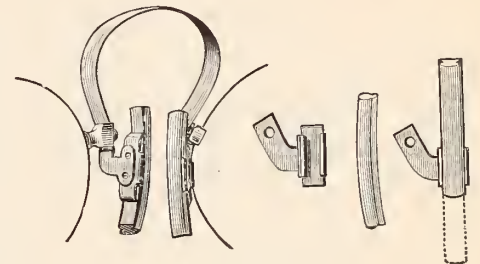

PATENTED.



# HAMMEL, RIGLANDER & Co.,

35 Maiden Lane, New York.

# Don't Sell a Trunk Strap

for a leather belt! Did you ever watch a woman put on or take off a trunk strap, either on a trunk or on herself? Did you ever see the strap thereafter? Then let her try our "ECCENTRIC" belt and see her delight at finding a belt that LOCKS ITSELF just as tight as she desires and opens in a second.

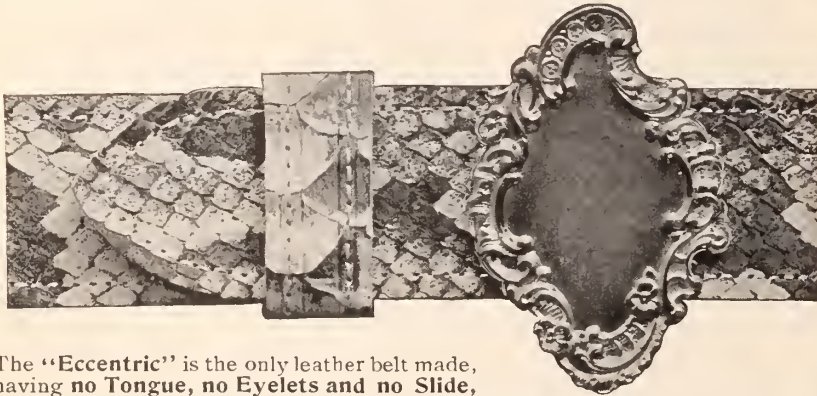

The "Eccentric" is the only leather belt made, having no Tongue, no Eyelets and no Slide, that ADJUSTS ITSELF and has solid front sterling buckles, which being independent of the belt will enable you to sell several different colored leathers, to match the wearer's dresses, with each buckle.

Have you seen our Belt Hook by using which our belt can be worn with a shirt waist?

Sold to Jewelers only. Samples on Application.

THE FINEST BICYCLE BELT IN THE WORLD.

SPIER & FORSHEIM.

31 1/2 Maiden Lane,



PATENTEES,  
NEW YORK.

## Letters to the Editor.

### PROGRESS OF THE TORREY BANKRUPTCY BILL.

WASHINGTON, D. C., April 28, 1896.

Editor of THE JEWELERS' CIRCULAR:

It affords me pleasure to thank you for your edition of the 22nd instant and to say that the space therein devoted to our bill will certainly have great influence in its favor.

The consideration of the bill was entered upon in the House to-day and Gen. Henderson, the Chairman of the Judiciary Committee, made a great speech in its behalf.

The vote will be taken on Saturday of this week at 4 P. M.

If our friends all over the country do their duty by urging their representatives to support the bill it will be passed in the House by a very large majority.

Thanking you on behalf of the men and bodies named on this letter head for your kindness, I am,

Very sincerely and truly yours,  
JAY L. TORREY.

### ADVOCATES REDUCTION OF THE TARIFF ON PRECIOUS STONES.

NEW YORK, April 28th, 1896.

Editor of THE JEWELERS' CIRCULAR:

Your esteemed favor of yesterday at hand, and please accept our thanks for the information contained therein. We have carefully looked over the copies of THE CIRCULAR which you sent us, and may mention that we are in favor of the reduction in the duty on diamonds from 25 per cent to 10 per cent. and will note the same in *The Financier*. If agreeable, we will be glad to exchange with you. I send you a copy of *The Financier* under separate cover.

R. D. BONIFACE.

### The Death of John H. Tissot, Sr.

John H. Tissot, Sr., an old and at one time well known manufacturer of watch cases, died suddenly of pneumonia April 22, at his home, 75 Adelphi St., Brooklyn, N. Y. His wife's death occurred but 10 days before.

Mr. Tissot was born in Switzerland in 1825, and came to America when he was 20 years old. He was captain of Company E of the Fifty-fifth (French) regiment of New York, and served for three years during the war of the rebellion. He was also a member of Commonwealth Lodge F. and A. M., and Principal Lodge I. O. O. F., and Long Island Council, No. 173 Royal Arcanum. Four children, all married, survive him, one of whom, a son, was a member of the firm of Benfield & Tissot, watch case makers.

The funeral services were held at his late residence, Friday evening, and the remains were interred in Greenwood Cemetery.

St. Clair Fechner, jewelers' auctioneer, is conducting a sale for Jeweler Plack, 1013 N. 3d St., Harrisburgh, Pa.

George Cowles, Quarryville, Pa., who has been in poor health for some time, is recovering.

A. WALLACH & CO.,

Manufacturers of

**Gold Chains,**

11 Maiden Lane,

Adolph Wallach, (

NEW YORK.

L. ROSENBERGER.  
M. ROSENBERGER.

A. WALLACH & CO.

This card

appeared in the "Jewelers' Circular" of April 15, 1870

For 50 years

Wallach Fine Gold Chains have been recognized as the standard.

We have

recently removed to new quarters at

37 and 39 Maiden Lane,

Lorsch Building,

Room 8.

These well-known Razors, the quality of which is warranted, possess this great advantage, that they may be used for ten years before they require actual sharpening. Before using them, it is necessary to rub them on good leather strap. Lecoultre's Straps (to be had with the Razors), should be used in preference to others.



THIS CUT IS TWO-THIRDS OF REGULAR SIZE.

**MATHEY BROS., MATHEZ & CO.,**

SEND FOR PRICE LIST

SOLE AGENTS. 21 & 23 Maiden Lane, N. Y.

**Condition of the Affairs of Lincoln, Bacon & Co.**

PLAINVILLE, Mass., April 29.—A statement was sent yesterday to the creditors of Lincoln, Bacon & Co. which reads as follows:

A meeting of the creditors of the firm of Lincoln, Bacon & Co. was held at Plainville, Mass., on the 14th day of April, 1896. There was represented thereat about \$95,000 in amount. The attorney for the firm made a statement of the assets and liabilities as follows: Assets were of book value, \$147,941.06; liabilities, \$115,363.55. He also stated that the assets in New York, consisting of outstandings and stock, of the book value of about \$60,000, had been conveyed to Mr. James D. Lincoln in consideration of \$42,500 of notes and other indebtedness to him, actual and contingent, and that Mr. Lincoln had a lien upon one-half the real estate in Plainville for the balance of the indebtedness to him. On behalf of Mr. Lincoln it was stated that if all the creditors and the firm would agree to it, he would only require payment in full of the debts amounting to about \$20,000, on which he was individually liable, and would turn over all the property he had received and relinquish all his interest in the real estate, and would receive and hold all the property of the firm as trustee for all the creditors, including himself, for the balance due him, and close up the business and realize on all the assets as speedily as possible, and make dividends from the proceeds pro rata. After some discussion a committee of three, consisting of F. G. Pate, D. S. Spaulding and F. B. Byram, was chosen to investigate the affairs of the firm and report to the creditors. On motion of Judge Fox it was voted, "That the creditors present, so far as at present informed, are inclined to look with favor on Mr. Lincoln's proposition."

The committee immediately proceeded with its labors, and have continuously carried them on, and after a full, careful and thorough investigation, made and submit the following report:

Assets (as appraised by the committee). Real estate, Bisbee House, \$1,500; Morrison House, \$900; Boarding House, \$3,500; Ward House, \$1,500; Schroeder House, \$1,500; factories, \$20,000; engine and

boiler, \$2,500; total, \$31,400. Finished and unfinished goods, stock and supplies, \$15,000; machinery, \$8,872; tools, \$8,311.30; water works \$1,000; rents due and uncollected, \$800; cash in bank, \$1,233.47; stock in New York, taken at salable value, \$29,685.58; book accounts, taken at face, \$28,297.30; sales made and not entered, \$150; bills receivable, \$1,313.60; total, \$126,062.24. Wade, Davis & Co owe \$886.39 for rent.

Liabilities—James D. Lincoln, \$4,239.83; \*\*Plainville Savings and Loan Association, \$12,500; \*\*A. F. Bennett, \$5,000; F. M. Whiting & Co., \$5,000; \*\*Northboro National Bank, \$4,000; \*\*Slater National Bank, \$4,000; \*\*Manufacturers' National Bank, \$3,000; \*\*Producers' National Bank, \$3,000; Mary F. Reed, Administratrix, \$2,950; \* F. D. Lincoln, \$1,073.03; \*\*International Trust Co., \$5,000; \*\*Chatham National Bank, \$7,500; \*\*Daniel Brown, \$1,000; Morris Lincoln, \$5,000; \*\*Lewiston National Bank, \$2,000; H. A. Cowell, \$1,000; H. E. Thompson, \$150; \*\*Pacific National Bank (secured), \$2,700; New York Merchandise creditors, \$424; W. H. Riley & Son, \$2,431.58; White & Shaw, \$559.01; Charles T. Guild, \$438.31; H. F. Carpenter & Son, \$207.90; A. H. Bliss & Co., \$195.15; C. E. W. Sherman & Son, \$26.23; Plume & Atwood Manufacturing Co., \$136; Wrentham taxes and interest, \$1,199.22; sundry merchandise creditors, \$466.60; total, \$115,477.01.

\* To those creditors marked with a single star Mr. James D. Lincoln is individually liable.

\*\* To those creditors marked with a double star, Mr. Harland G. Bacon is individually liable.

In addition to the above liabilities the name of Lincoln, Bacon & Co. is endorsed on the following notes:—North Attleboro National Bank, \$4,875.00; Pacific National Bank, \$2,000. As to these notes there is now some dispute as to whether or not the firm is liable. As to the note of Morris Lincoln (above) there is now some dispute as to whether or not Mr. James D. Lincoln is individually liable. There is also due to employees the sum of \$1,500.00 which must be paid in full. And your committee recommends to the creditors that the proposition of Mr. Lincoln be accepted, and state that it has examined the same, a copy of which you have received, and that said agreement meets with its approval.

Gem jewelry, so lavishly worn, not only abroad but at home, greatly enhances the Oriental effect in dress, after which fashionable women are striving just now.

Don't Fail  
To Ask Your  
Jobber For



BATES & BACON  
"FAVORITE"  
14K



BATES & BACON  
"ROYAL"  
14K



BATES & BACON  
"PURITAN"  
14K

**BATES & BACON**

**GOLD FILLED WATCHCASES.**

**UNLIKE OTHERS?**

SPLIT BAMBOO RODS. Trade Retail Price. Price.

Fly or Bai', 11 patterns to select from, each, \$2.97 \$5.00



INQUIRIES ANSWERED.

**ABBAY & IMBRIE,**  
21 VESEY ST.,  
New York.

136 page FISHING TACKLE Catalogue Free

**DR. KNOWLES' PRIVATE COURSE IN OPTICS.**

Lectures with Diploma \$25.00

Those who desire to study with the Doctor will send in their application. Students received at any time.

CORRESPONDENCE COURSE PERFECTED.

*The Key to the Study of Refraction.* 50c. per copy,

For Sale by  
R. H. KNOWLES, M. D.,  
189 Broadway, NEW YORK.  
Care of JEWELERS' CIRCULAR.

ALL KINDS OF  
**S KELETON S**  
FOR  
SILVERSMITH  
MANUFACTURED BY  
**S CHULDER BRO S**

FACTORY AT SOLINGEN, GERMANY. FOUNDED 1850  
545 & 547 PEARL ST., NEAR BROADWAY, NEW YORK

**RAZZLE RINGS**

MADE BY  
**HENRY C. HASKELL,**  
11 John St., New York.

Send For New Price List.

- - EMMONS - -

**ASSOCIATED LAW OFFICES.**  
PORTLAND, OREGON. SEATTLE, WASH. TACOMA, WASH.  
Foreign Business a Specialty.



**NO TRAP**  
TO BREAK OR CURL, YET

**TRONG,**  
**TYLISH**

SEND FOR SAMPLES AND PRICES OF OFF-SET EYE-GLASS CASES TO MANUFACTURERS

LOW IN PRICE THAT EVERY UP-TO-DATE OPTICIAN SHOULD BUY THEM.

AND

**H. E. KIRSTEIN & CO.,**  
ROCHESTER, N. Y.

**An Important Point of Inter-State Commerce Involved in This Case.**

BUTTE, Mon., May 1.—The case of the Kent & Stanley Co. Ltd., against H. S. Tuttle, E. O. Dugan, J. W. Cotter & J. H. Leyson, trustees of the Tuttle-Dugan Jewelry Co., was tried before Judge Speer last week without a jury. The action was brought to recover \$158 for jewelry furnished by the plaintiffs during 1894. The Kent & Stanley Co. had already obtained judgment against the Tuttle-Dugan Co., but they sought in this action to hold the defendants, as trustees of the latter company, liable for the debts of the corporation by reason of their failure to file an annual report between Sept. 1 and 20, 1894, as required by law.

The defendants set up that plaintiffs had no right to sue, by reason of their being a foreign corporation and had failed to file a copy of their articles of incorporation in this county and with the Secretary of State, and had failed to appoint an agent upon whom service of process could be made, as required by the provisions of the law. The case was decided in favor of the defendants, Judge Speer holding that a foreign corporation doing business in the State must comply

strictly with the requirements of the law and must appoint a sueable agent within the State, else they have no right to commence an action to recover money.

The case will be appealed to the Supreme Court as an important question is involved, effecting all business corporations outside the State who ship goods to Montana and are compelled to bring suit for their pay. The point is made by counsel for plaintiffs that the law in regard to foreign corporations is unconstitutional, as being against the provisions of the constitution of the United States and is also in conflict with the Inter-State Commerce Law.

**Assignment of one of the Oldest Jewelers in New Hampshire.**

LITTLETON, N. H., May 2.—Elbridge Flint, the oldest merchant in Littleton, and the leading jeweler of northern New Hampshire, has made an assignment in favor of his creditors. An assignee will be appointed at a meeting of creditors to be held June 4th.

Two well dressed young men entered the jewelry store of A. E. Rogers, Scranton, Pa., April 28, and stated they wanted to purchase

a solitaire. A number of diamonds were shown them on trays by Mr. Rogers. One diamond, marked \$150, attracted their special attention, and one of the young men remarked that he would purchase it and call for it a few days later. While he was discussing the diamond with Mr. Rogers his companion was scrutinizing some scarf pins in a case at the other end of the store, and presently asked Mr. Rogers the price of one of the pins. Mr. Rogers left the other customer and exhibited some of the pins, and discussed their value with him some minutes. He finally selected a pin for \$4.50, and with his companion then departed. After they had left the store Mr. Rogers discovered the \$150 diamond was missing.

James Clegg, jeweler, 14 E. Seneca St., Buffalo, N. Y., allowed a smooth talking stranger to swindle him a few days ago. The young fellow was well dressed, and when he entered the store, asked to be shown some articles of jewelry he pointed out in the case. Finally he concluded he did not want to make a purchase and went out. An hour later Mr. Clegg discovered that a \$50 gold locket set with diamonds was missing, and the fact was reported to the police.

# COMBINATION BELT AND SKIRT SUPPORTER.

(PATENT APPLIED FOR.)

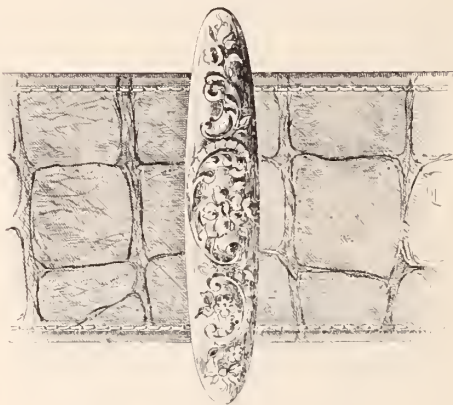

UTILITY,  
SECURITY,  
SIMPLICITY.



## DEITSCH BROS.,

— MAKERS, —

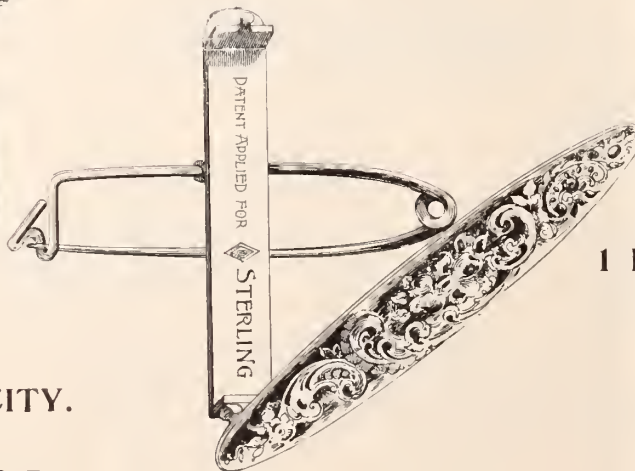

1 Inch, \$12.00 Doz.

1 1/4 Inch, \$13.50 Doz.

1 1/2 Inch, \$15.00 Doz.

## 7 East 17th St.,

NEW YORK.



**The Date Fixed for the Trial of Herman Keck.**

PHILADELPHIA, Pa., May 2.—Charles A. Hess, of the Diamond Importers' and Cutters' Protective Association, New York, was in Philadelphia Wednesday, and had a long conference with United States District Attorney Beck regarding the Herman Keck smuggling case, the trial of which has been fixed for May 18.

It is understood that Keck's defence will be a general denial of the smuggling charge, on the presumption that he was outside the jurisdiction of the United States, and that if any smuggling was attempted at all, it was on German soil. The sale of the diamonds has been postponed until after the trial.

When questioned by a CIRCULAR reporter Friday, Mr. Hess said: "The District Attorney has generously invited me to take part and assist him at the trial, which will probably come up about May 20th. Keck will be called to plead May 18th."

**Business Prospects Hopeful in Cleveland.**

CLEVELAND, O., May 1.—The jewelry business is very quiet in the city this Spring, but the undercurrent is hopeful, and jewelers are taking a more optimistic view of the situation than has been their habit for the past few seasons. The convening of the General Conference of the Methodist Episcopal Church in the city has brought out a line of city and denominational souvenirs in which a good trade is anticipated. This being the centennial year of the city, to be celebrated by a series of events covering six weeks of the Summer, trading in souvenir and kindred lines is expected to be good. Some of the local jewelers are showing large lines of sterling silver table goods, and report a good inquiry for them.

**Find of a Black Pearl at Pawtuxet.**

PROVIDENCE, R. I., May 1.—One of those freaks of nature called black pearl was found yesterday in a quahaug shell, by James Badmington, of Pawtucket. The stone has a fine luster, is fully half an inch in diameter and mottled on the top with dark pink, the bottom being slightly flattened. The quahaug in which the prize was found was of unusual shape, and appeared to be so deformed in growth that when he took it in his hand Mr. Badmington hesitated whether to open it or throw it away. He finally inserted the knife beneath the shell, and there, imbedded in the quahaug itself, saw what looked like a

dark maroon colored bean, and that was pronounced by those who were shown the curious object to be a black pearl. The pearl is flattened on the under side, the top being rounded. While the bottom and sides are lustrous with a dark maroon, at the top this shades off into a dark pink, then a lighter shade, and in the center is a small spot nearly white. The luster of the pearl is most important, for the stone is ruined by the touch of the wheel of a lapidary.

These gems are extremely rare, and command sometimes high prices from lovers of the unusual in jewelry. They are found in oysters, quahaugs and other shell fish, and vary in value according to their luster, shape and color. John M. Mackay, the bonanza king, has a large Eastern black pearl, for which he paid \$25,000, and for a mate to which he has offered \$50,000. This pearl was taken from the shell of an oyster in one of the Eastern archipelagoes, and is of unusual size and color, being as large as the thumb of an ordinary man. Henry Whittier, of Henry Whittier & Son, jewelers, of this city, recently saw a black pearl in New York, which, although having a hole drilled through it, was still worth \$3,500. One found on Pawtuxet Neck, R. I. early this year, was purchased by Mr. Whittier for \$90, and sold again for more than double that sum.

News of Mr. Badmington's find spread rapidly through the village, and old men who had been opening oysters and quahaugs for over a generation without finding one of these rare manifestations of the pearl forming tendencies of shell fish, flocked to see the stone. These two stones are the only ones found by the men of Pawtuxet for years past, although for sometime everyone opening either oysters or quahaugs will keep a sharp watch for another such prize.

**The Tower Clock for the Government Building in Mankato, Minn.**

WASHINGTON, D. C., May 2, 1896.—The Secretary of the Treasury has awarded to Johnson Temperature Regulating Co., New York, the contract for placing a tower clock in the United States Post Office building in Mankato, Minn., on their bid of \$1,065; time two months.

No line of rings manufactured in this country is better or more favorably known than those produced by the Ostby & Barton Co., Providence. This concern is now considering the adoption of a trade mark for the better protection of these goods from the imitations of other manufacturers.



**Gifts**

For Wedding or Anniversary Gifts no more appropriate article could be selected than one of Roger's beautiful statuette groups. The one illustrated herewith lists at \$12.00. It represents Mr. Jos. Jefferson (who posed in person) as Bob Acres in "The Rivals." There are over forty subjects to select from, at from \$6.00 to \$20.00. Correspondence with Jewelers invited. There's money in it. Beautiful catalogue mailed free.

**Rogers Statuette Co.**

441 Pearl St., N. Y.

**Watchman's Improved Time Detector**

12 and 24 Different Keys with Safety Lock Attachments.

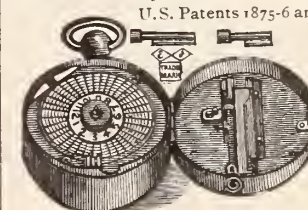

U. S. Patents 1875-6 and 7. Reissued, 1880. This Watchman's Time Detector contains all latest improvements. The only perfect instrument in the market. It cannot be tampered with successfully. Warranted in every way.

Send for circular  
E. IMHAUSER, 206 B'way New York U. S. A.

**PHILIP BISSINGER & CO.,**

IMPORTERS OF

PRECIOUS STONES, PEARLS, CORALS and GARNETS,

ANNOUNCE THEIR

**REMOVAL**

FROM 22 TO

20 JOHN ST., N. Y.

## THE POPULARITY OF THE CHAFING DISH.

### History and Development of the Chafing Dish—Its place in Domestic Economy—Chafing Dishes Produced for the Jewelry Trade.

THE desire of the American people of today to acquire the greatest possible advantage with the least possible expenditure of energy is perhaps the main reason why the chafing dish has become such a widespread element in the domestic economy; and, as the tendency of this desire is certain to expand, as the years pass over our heads, so certain is it that the chafing dish will more and more become a recognized and essential article of utility in the household. The popularity of the chafing dish at the present time may strike the superficial observer as having the complexion of a fad; but if we look deeper into the matter we find that its spreading use is founded upon the psychological condition of the people. They are tired, and they will employ a minimum of force to gain ends. Of course at the present time an element of pleasure is contained in the impulse which leads one to use the article; but this element will soon become obliterated by the increasing desire to reserve energy for performing the necessary actions of life. When that time arrives, the chafing dish will occupy in the domestic economy, a position relatively the same as that of the gas stove or gas radiator.

The literature of the chafing dish is extensive. Among the works that have come under the writer's notice are: "One Hundred Recipes for the Chafing Dish," by H. M. Kinsley, of the Holland House, New York, and Kinsley's, Chicago, published by the Gorham Mfg. Co., New York; "The Chafing Dish Supper," by Christine Terhune Herrick, Chas. Scribner's Sons, New York; "The Bachelor

and the Chafing Dish," by Deshler Welch, published by F. Tennyson Neely, Chicago; "What can be done with a Chafing Dish," by H. L. S., published by John Ireland, New York. It is from the first work mentioned that the data for the historical matter in this article is derived.

The chafing dish is not an invention of recent date. More than two thousand years ago it fulfilled its office as the promoter of man's palatable pleasures at the table of the wealthy Greeks and Romans. A writer quotes from Seneca (b. 3 B. C.—d. 65 A. D.) as follows as referring to the appearance of the chafing dish: "Daintiness gave birth to this useful invention in order that no viand should be chilled and that everything should be hot enough to please the most pampered palate. The kitchen follows the supper." That piety received an impetus from it is to be inferred from the fact that a chafing dish was a familiar adjunct on the altars in old French churches. The chafing dishes of the ancient epicures were exquisite in workmanship and beautiful in design; but it is hardly necessary to add that they were not as useful as the modern appliances.

"Each of these elegant utensils," says Soyer, who has written exhaustively of the lives and customs of the Greeks and Romans, "was supported by three geese. It measures seven inches from the extremity of one of the bird's heads to the opposite edge of the circumference. The tray is 15 lines or an inch and a quarter deep, and the feet raise it about two inches above the plane. The three geese have

their wings spread and terminate by neat feet. The heads, raised on the breasts, form graceful handles. These chafing dishes arranged systematically on the sigma, produce a delightful effect."

Cicero undoubtedly referred to the chafing dish in making one of his most telling points in his first public law case. He was engaged to defend Sextus Roscius, who was accused of murdering his father, against Sylla, who sold the estates of Roscius for a trifling sum to his favorite slave, Chrysogonus. In making a summary of the wealth of this slave and an exposition of his luxurious living, Cicero says: "A house filled with Corinthian and Delvan vessels, among which was that celebrated stove which he so lately bought at so great a price, that passers-by, who heard the money counted out, thought a farm was being sold." This was the anthespa to which Cicero referred, and is described as "a kind of sauceman of Corinthian brass of considerable value, and made with such art that its contents cook instantly and almost without fire. This simple and ingenious vessel possessed a double bottom, the uppermost one holds the light delicacies destined for the dessert and the fire is underneath." So popular was the chafing dish that a semblance of it was used for a table ornament, just as floral pieces are used now.

In the middle ages, when strife and anarchy reigned, this utensil of polite life fell into disuse. But in the fifteenth century, when learning received an impetus, it is heard of again. Francis Bacon in a treatise on "Physiological Remains," used the silver chafing dish as a standard of comparison for durability in metals. He charges experimenters "to make proof of the incorporation of silver and tin, in equal quantity, or with two parts silver and one part tin, and to observe whether it will



## A Perfect Picnic

to sell our goods. Our catalogue of nickel plated and copper Chafing Dishes, Chafing Dish Outfits, Fancy Brass and Copper Kettles sent on request.

See that our Trade  
the only Lamp  
ing flame.



Mark is on your Lamp,  
made with a regulat-  
ing flame.

## S. STERNAU & CO.,

36 PARK PLACE,

NEW YORK.



Consisting of Chafing Dish and Cover Stand and Lamp Hot Water Pan (Cutlet Dish if wanted)

Form, oval. Finish, polished. Handles, ivory.

PLATED CHAFING DISH, No. 0570. Capacity, five half pints.



Consisting of Chafing Dish and Cover Stand and Lamp Hot Water Pan

Form, round. Finish, polished. Handles, ebony

PLATED CHAFING DISH. Made in two Sizes. No. 0620, Capacity, five half pints. No. 0625, Capacity, three half pints.



Consisting of Chafing Dish and Cover Stand and Lamp Hot Water Pan Cutlet Dish

Form, round. Finish, satin or polished. Handle, ebony

PLATED CHAFING DISH, No. 0495. Capacity, four half pints.



Consisting of Chafing Dish and Cover, Stand and Lamp, Hot Water Pan

Form, round. Finish polished. Handles, ivory

STERLING SILVER CHAFING DISH,  $\frac{925}{1000}$  FINE, No. 25. Capacity, three half pints.

### GORHAM MFG. CO., Silversmiths.



NEW YORK; Broadway and 19th St., 23 Maiden Lane.

BOSTON; 43 West St., CHICAGO; 137 State St., SAN FRANCISCO; 118 & 120 Sutter St.

Works at Providence, R. I. No. 0560, four half pints. No. 0565 three half pints.

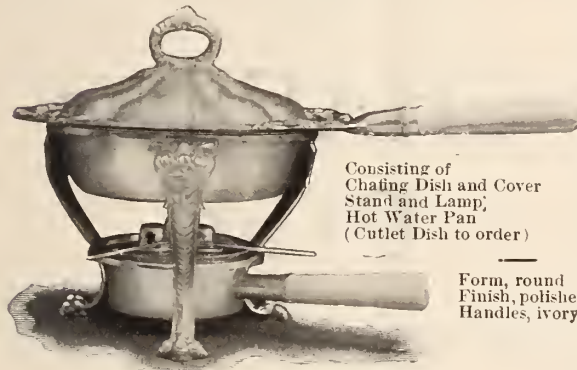

Consisting of Chafing Dish and Cover Stand and Lamp, Hot Water Pan (Cutlet Dish to order)

Form, round. Finish, polished. Handles, ivory

STERLING SILVER CHAFING DISH,  $\frac{925}{1000}$  FINE, No. 10. Capacity, four half pints.

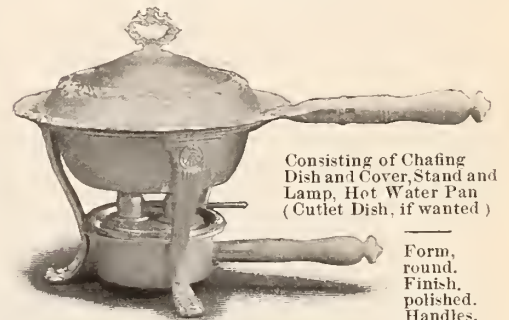

Consisting of Chafing Dish and Cover, Stand and Lamp, Hot Water Pan (Cutlet Dish, if wanted)

Form, round. Finish, polished. Handles, ivory.

PLATED CHAFING DISH. Made in two sizes.

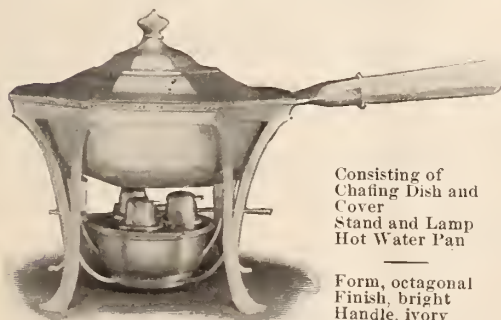

Consisting of Chafing Dish and Cover Stand and Lamp Hot Water Pan

Form, octagonal. Finish, bright. Handle, ivory

STERLING SILVER CHAFING DISH, No. 50. Capacity, 4 half pints.

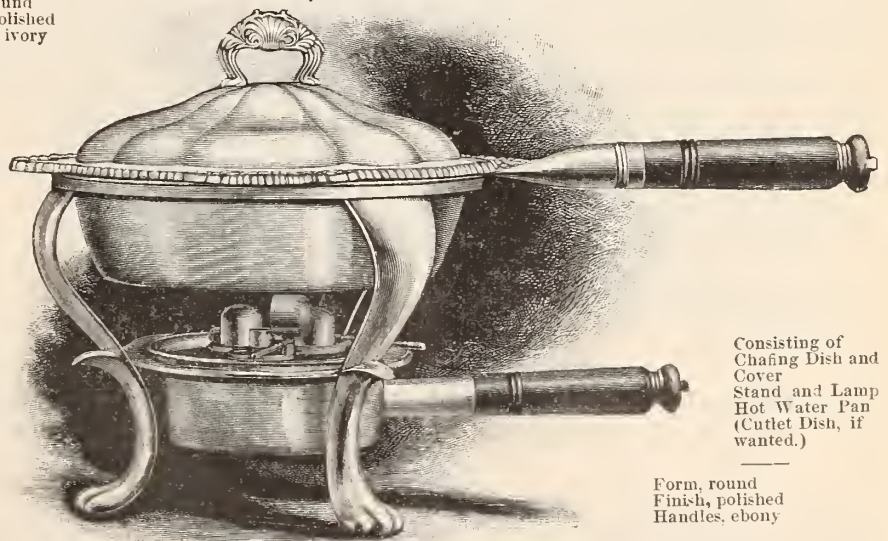

Consisting of Chafing Dish and Cover Stand and Lamp Hot Water Pan (Cutlet Dish, if wanted.)

Form, round. Finish, polished. Handles, ebony

PLATED CHAFING DISH. Made in two sizes. No. 01005, Capacity four half pints. No. 01010, Capacity, three half pints.

endure the ordinary fire which belongeth to chafing dishes, posnets and such other silver vessels."

The chafing dish is a cosmopolitan vessel; it belongs to all nations, and was no less appreciated by the French, than the English. It appeared in America in 1720. The colonists having overcome the difficulties incidental upon the making of a new country, began to appreciate and to desire the luxuries and adornments of refined living. The father of a rich bride of the day, who desired to give his daughter "a truly elegant outfit," in the list of household furnishings he ordered from England, included "6 small brass chafing dishes, 4 shillings apiece."

"The mastery of the chafing dish is one of the undisputed arts where a man and women may share equal privileges and triumphs. A man may prove his skill in cooking with it, without detracting from his dignity, and a woman can scarcely manipulate it without adding to her charm," writes Mr. Kinsley.

The chafing dish has become an important and profitable item in the stocks of many jewelers, and as it is an article of ever increasing popularity, we have deemed it desirable to furnish some facts regarding the article to those dealers who have not as yet felt the pressure of the demand for it, and to give them some idea of the various lines of these goods on the market.

S. STERNAU & CO.

S. Sternau & Co., 36 Park Place, New York,

are perhaps the only house in America that make chafing dishes and tea kettles exclusively. They have been established since 1885, and have won a high position in this branch of industrial art. Their line of chafing dishes is very extensive, being made of copper or nickel plate, their special feature residing in the fact that they are doubly tin-lined. They are fitted with the firm's own improved regu-



This shows the lamp burning full flame.

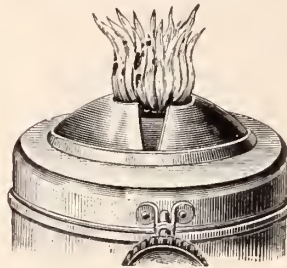

This represents about the correct size of flame for simmering.  
THE STERNAU IMPROVED ASBESTOS LAMP.

lating asbestos lamp, which is adapted to increase or diminish the heat of the flame, as much or as little as desired. The lamp is asbestos packed and ventilated. There is perfect combustion, consequently maximum heat. The fact that the size of the flame can be regulated at will is an obviously essential feature of successful cooking, considering that three-fourths of everything cooked in a chafing dish require an increasing or diminishing heat. The firm issue a pretty booklet entitled "The Uses of the Chafing Dish," copyrighted in 1895 by themselves. It furnishes valuable information on the subject, and illustrates characteristic scenes in which the chafing dish plays a salient role. The firm do a large business in these articles and ship goods to all parts of the earth.

GORHAM MFG. CO.

The Gorham Mfg. Co., 19th St. and Broadway, New York, have devoted a great deal of attention to the chafing dish, and their line is very extensive, comprising as many as 20 designs, and ranging in size from that which will serve three persons to what will serve 10 persons. The major part of this line is made in Gorham plate, the basis of which is the finest quality of nickel and German silver, remarkably hard and ringing, upon which is laid a very thick plating of pure silver; each piece is silver soldered at every joint, making it practically indestructible, and making it in beauty and utility almost equal to solid silver. In addition to the Gorham plate dishes the com-



NICKEL PLATED. — SILVER PLATED. — SILVER SOLDERED.

PATENT REGULATING LAMP.

ROGERS & BROTHER,

The public has come to appreciate that the

# CHAFING DISH

has solved the problem of luxurious living at a nominal cost.

LARGE VARIETY  
OF PATTERNS,  
ALL SIZES.

16 CORTLAND ST., WATERBURY,  
NEW YORK. CONN.

pany produce a number in sterling silver 925-1000 fine. To enumerate some specimens of the Gorham line of chafing dishes we may specify plated dish, capacity four half pints, consisting of chafing dish and cover, stand and lamp, hot water pan, cutlet dish, the form being round, the finish satin and polished, and the handle ebony; plated dish, five half pints, consisting of same pieces,



CHAFING DISH—GORHAM MFG. CO.

form oval and finish as foregoing; plated dish, three half pints, consisting of same pieces, form round, finish polished, handles ivory; plated dish, five half pints, same pieces, form oval, finish polished, handles ivory; plated yacht chafing dish, four half pints, consisting of dish and cover, stand and lamp and hot water pan, form round, finish polished,

handle ebony and detachable; sterling silver chafing dishes, of three, four or five half pints, consisting of the regular pieces, with ivory handles, and sterling silver and bronze dishes of four half pints capacity, the dish and cover being of sterling silver, the stand bronze and the hot water pan and lamp copper. In these articles the cutlet dish and cover are adapted to form an independent table utensil. The dishes are fitted with a new asbestos regulating lamp, or with a lamp consisting of three burners, constructed for regulating the flame. Both these lamps work perfectly.

MERIDEN BRITANNIA COMPANY.

On a separate table in the beautiful New York store of the Meriden Britannia Co., 1130 Broadway, is set a specimen of a line of chafing dishes which is a feature of considerable magnitude in the company's production. An entire wall case, twelve feet wide, is devoted to a display of these articles. Some of the designs are elegant. In the line are seen dishes with capacity for six half pints, five half pints, three half pints, and in round and square forms. These chafing dishes are principally of nickel silver, silver soldered; though they show a line of copper with silver plate, and nickel plated or planished copper. A comparatively recent product of the company is a yachting chafing dish, the pan of which swings with the heeling of the yachts, thus maintaining a horizontal position under all circumstances. The Meriden dishes are fitted with a new asbestos regulating lamp.

ROGERS & BROTHER.

Rogers & Brother, 16 Cortlandt St., New York, in response to the demand for chafing dishes, have placed on the market a large variety of these goods, in the different sizes. The dishes are of silver plate, solid silver soldered, and are fitted with an improved regulating asbestos lamp, by which the flame can be increased or diminished at will; it produces the maximum of heat, and is thus economical in the expenditure of alcohol.

ROGERS, SMITH & CO.

Among the first and largest producers of chafing dishes for the trade are Rogers, Smith & Co., Meriden, Conn. These goods are made in the various capacities, and in many designs. These dishes are fitted with a patent improved regulating asbestos lamp.

Other manufacturers of chafing dishes for the jewelry trade are: Pairpoint Mfg. Co., New Bedford, Mass.; Simpson, Hall, Miller & Co., Wallingford, Conn.; Wilcox Silver Plate Co., Meriden, Conn.; Middletown Plate Co., Middletown, Conn.

The police authorities of Lafayette, Ind., have a description of Lewis Beck, a watchmaker, who robbed a jewelry store at Peru recently, and who was known to have gotten off a west-bound passenger train on the Wabash. The fellow seems to have pretty well gutted the establishment, having stolen 15 to 20 gold and silver watch cases, two or three good watches, 60 or 70 valuable rings.

# ROGERS, SMITH & Co.

MADISON SQUARE,  
NEW YORK.



MERIDEN,  
CONN.

# GOLD AND SILVER PLATE.

### Retirement of J. E. Hyde's Sons, and Transfer of the Agency for the Jurgensen Watch.

The agency in America of the Jules Jurgensen watch has been transferred from John E. Hyde's Sons to Schulz & Rudolph, 28 John St., New York. J. L. Hyde, who constituted the personnel of the old house of John E. Hyde's Sons, has been ill for some time past, and this, combined with his desire to retire from business, led to the transfer.

Eugene Van Benschoten, who has been with John E. Hyde's Sons for about 40 years, has identified himself with Schulz & Rudolph, and will look after the Jurgensen watch interests for the firm.

Jules Jurgensen, the maker of the world renowned watch, was born at Locle on July 27, 1808. A year or two later, Urbane, father of Jules, with his family returned to Copenhagen, where he remained until his death. As a young man Jules worked at the construction of chronometers under the eye of his father, his spare time being devoted to the study of physics, mechanics and astronomy. At the age of 27 years he returned to Switzerland; he afterward visited Paris and London, where he improved his knowledge in the foregoing sciences. In 1834 he established in Locle a branch house of his father's firm in Copenhagen, and devoted his attention principally to the construction of pocket chronometers, employing the various improvements in watch mechanism that he had conceived during his studies, the result being that marvel of excellence as a timepiece, the Jurgensen watch. The calibers used in these watches cannot be improved upon, while the escapements are eminently suitable for precise timing. It may well be said of Jules Jurgensen that he contributed in a large degree toward the artistic development of horology in Switzerland. He designed more than 30 calibers, invented a thermometer which was warmly approved by the Academy of Sciences, draughted sketches of seconds and half seconds, and constructed several astronomical timepieces after his father's plans, introducing into them several adjuncts of his own invention. He passed the last 10 years of his life in Geneva, and died on Dec. 17, 1877. His business descended to his son, Jules F. U. Jurgensen, who worthily maintains the high reputation of the name of Jurgensen.

The business of John E. Hyde's Sons, formerly at 22 Maiden Lane, went out of business Feb. 1st. Jonathan L. Hyde, the sole remaining partner who retired, is now very ill with paralysis. The business was originally started by John E. Hyde in 1825, who then began importing foreign watches, and later admitted his sons, Jonathan L., Jno. Joseph, and Wm. H., continuing under the style of Jno. E. Hyde & Sons. The firm bought watches from several European makers which were stamped with their name and sold as Jno. E. Hyde & Sons watches. After the panic in 1837, Jules Jurgensen, the elder, one of the principal watchmakers with whom this firm dealt, upon the advice of Jno. Jos. Hyde, commenced

to bring out watches for the American market under his own name, and the Hyde firm became his American agents. When John E. Hyde's Sons succeeded the old firm, they continued the agency for the watches of the elder and later for the younger Jules Jurgensen up to Feb. 1st, this year.

John Joseph Hyde died about 1890, and Wm H. Hyde, who retired several years ago, is now in Florence, Italy. Jonathan L. Hyde, who alone continued the business of late years, was forced to give it up owing to his ill health, the result of a stroke of apoplexy about three years ago.

### The Torrey Bankruptcy Bill Passed by the House.

The New York Jewelers' Association are in receipt of the following telegram:

"May 2, 1896, Washington, D. C. Mr. P. T. Tunison, Secretary, 145 Broadway, N. Y.

"After five days debate the Bankruptcy Bill passed the House by a vote of 157 to 81; clean majority of 76.

(Signed) J. L. TORREY."

The bill will now go to the Senate, provided there is time enough this session to consider it; otherwise it will be carried over until next December, when the Senate will again convene. In the meantime the advocates of the bill, through their representatives, will visit the different Senators at their homes and personally interest them in voting for the passage of the bill.

### No Clue to the Couple Who Robbed M. G. Cohen.

PITTSBURGH, Pa., May 3.—A man and a woman walked into the jewelry store of M. G. Cohen, April 2d, and asked to be shown wedding presents. Only one clerk was in the store at the time. While showing goods the clerk's back was turned to the door. After the man and the woman had left two trays of diamonds were missed from the show window. They contained 56 rings, valued at about \$7,000.

The robbery was reported to the police. They have been working on the case ever since without getting a clue. The authorities in New York, Philadelphia, Cincinnati, Chicago, St. Louis and other cities were notified, but could learn nothing.

E. B. Jewett, assignee of Leo Lesquereux, Columbus, O., has been directed by the probate court to discontinue the sale of the goods, etc., at private sale, for the reason that the proceeds are not sufficient to warrant it. Judge Hagerty has also passed upon the validity and priority of the liens, holding that the chattel mortgage of S. S. Rickly for \$250 is the first and best lien. The mortgage of W. S. Furay for \$1,000 is second in order of priority.

August Bruder, Fort Wayne, Ind., expects to leave in a couple of weeks for a trip to Europe.

### The Diamond Tariff Case to be Taken to the U. S. Supreme Court.

An attempt is now being made to take the test case in reference to the diamond tariff, decided by the Circuit Court of Appeals, March 9th, to the United States Supreme Court, at Washington, for review on a writ of *certiorari*. The plaintiffs are Jos. Frankel's Sons, who are testing the law on a consignment of diamonds imported in September, 1894.

As already reported many times in these columns, duty on these goods was assessed by the Collector at 25 per cent. under Par. 338 of the Wilson bill, providing for precious stones cut but not set. The importers appealed, claiming that the stones were exempt from duty under Par. 467 of the Free List providing for "Diamonds; miners', glaziers' and engravers' diamonds not set, and diamond dust or borh, and jewels to be used in the manufacture of watches and clocks."

The Board of General Appraisers sustained the protest of the importers in an opinion which declares diamonds to be free, but on the appeal to the Circuit Court, Judge Townsend reversed the decision of the Board of Appraisers and declared diamonds dutiable. The appeal to the United States Circuit Court of Appeals, argued March 7th and 9th, resulted in a decision against the importers, the court affirming from the bench the decision of the court below on the opinion of Judge Townsend.

Curie, Smith & Mackie, counsel for Jos. Frankel's Sons, made application Monday to the Supreme Court at Washington for a writ of *certiorari* to review the judgment of the Circuit Court of Appeals. The petition for the writ attacks the decision of Judge Townsend as laying down principles contrary to a long line of decisions of the Supreme Court.

### Trans-Atlantic Voyagers.

TO EUROPE.

Charles H. Upmeyer, of Bunde & Upmeyer, Milwaukee, Wis., was a passenger on the *Aller*, which started for Southampton and Bremen Thursday.

Among the passengers for Europe on the *St. Paul* Wednesday were: Richard Horstmann, Berlin; Henry Lomb, of the Bausch & Lomb Optical Co., Rochester, N. Y.; Charles S. Pratt; and S. Sternau, of S. Sternau & Co., New York.

H. A. Beguelin, New York, sailed for Antwerp on the *Westernland* Wednesday.

Max J. Lissauer, of Lissauer & Co., New York, will sail May 21 on the *Augusta Victoria*.

FROM EUROPE.

G. Armeny New York, arrived from Europe last week on the *Majestic*.

Friday, May 1st, L. M. Barnes, of North Adams, Mass., entered on his 31st year in the jewelry business in that city. A complimentary item giving the history of Mr. Barnes' business career appeared in the *North Adams Transcript*, May 1.

**Boston.**

George H. Atwell, formerly with S. G. Brooks, has opened a new store on Dudley St., near Upham's Corner, in the Highland district.

Parker Ridler, recently with Bogle Bros. Co., and previously for 27 years with H. T. Spear & Son, will be located hereafter with Harwood Bros.

O. A. Drinkwater, of the Morrill Bros. Co., who has been seriously ill for several months, is improving slowly and hopes are entertained of his complete recovery.

Geo. A. Baron has just put in a specimen of the Waltham Electric Clock Co.'s newest model regulators, and will have it on exhibition for any who are interested in such timepieces.

William B. Learned, formerly superintendent of the E. Howard Watch & Clock Co.'s factory, has been awarded \$1,123 in his suit against the company to recover on a contract for services.

The trio of youthful burglars who entered the establishment of James Carr, in the Charlestown district last week, have been held for the grand jury. Property valued at \$3,000 was taken, but most of it was recovered.

Boston jewelers have received the new Elgin catalogues. One dealer pointed out to THE CIRCULAR correspondent that this catalogue places the prices of various kinds of material back where they were before the reduction.

John A. Jury, head watchmaker for George H. Richards, Jr., & Co. celebrated the 25th anniversary of his wedding last Friday, and was remembered with a handsome silver turban by his employer and associates in the establishment.

The early closing movement was begun by some of the manufacturers and their representatives May 2, among the firms that took Saturday afternoon for a holiday being Robbins, Appleton & Co., the Courvoisier-Wilcox Mfg. Co., and the Kent & Stanley Co., Ltd.

E. M. Poulin, who went to California about six months ago with a view to locating there if a favorable opening presented itself, has returned to Boston and will resume business here, believing that this city offers better opportunities than those of the Pacific coast.

Commodore Morrill, of the Morrill Bros. Co., whose handsome yacht has afforded so much pleasure to the members of the jewelry trade in previous Summers, has sold the swift little craft to the commodore of a Rhode Island Club. The *Navarch*, as the yacht was named, was capable of covering 19 knots an hour, and was recognized as the fastest launch in the harbor. Mr. Morrill states that owing to a large increase in his business interests he will be unable to devote much attention to yachting this Summer.

**Bangor, Me.**

A handsome new front is being put in at the store of the Tebbets Jewelry Co.

The only jewelry salesman in town last week was Jason Weiler, of Boston, who represents his own house.

He was formerly located in Maine, but moved his business to Boston some time ago.

Rhodes, the jeweler of Pittsfield, Me., is of an inventive turn of mind. Not long ago he conceived the idea of placing a clock upon the outer wall of his store, so that the good people of his town could have reliable time, in fact, have a town clock. This particular clock is in fine working order and keeps good time, but for a clock, it has no parallel in some respects. The gearing is to a certain extent the product of Mr. Rhodes' skill and requires winding but once a year. In a few weeks it will strike by water power and the gong will be the same as that used on street cars.

**Philadelphia**

Jacob Muhr will sail for Europe on the *Majestic* from New York on May 6th.

In connection with a general trade display, H. Muhr's Sons have a notable jewelry exhibit at the Bourse.

W. H. Podesta & Co., opticians, 113 N. 9th St., have opened a branch store at 606 Market St., Wilmington, Del.

William P. Sackett, of Sackett & Co., and Joseph A. Brazier, of J. E. Caldwell & Co., have been taking in the ozone at Atlantic City for several days.

Fifteen new members have been added to the Jewelers' Club since the last dinner of that organization. Ludwig Nissen, president of the New York Jewelers' Association, is now a member of the Jewelers' Club of this city.

Dr. William Zineman, of M. Zineman & Bro., has just returned to Philadelphia after a Winter in the south, where he was pursuing a course of optical studies. He will leave for Europe in a few weeks in order to continue his studies abroad.

George Smith was held in \$1,200 bail by Magistrate South, on Thursday last, on suspicion of having robbed the jewelry store of J. P. Trau, 14 N. 11th St. Smith was identified as the man who pawned a pair of diamond earrings stolen from Trau's store, as well as two pairs of opera glasses that were taken from a show case at the optical store of H. C. Boden & Co., 1232 Walnut St.

**Syracuse.**

Jos. Seymour, Sons & Co. are now located at No. 116 Kirk Block, West Fayette St., where the remainder of their stock will be disposed of.

E. C. Meacham, who has been on the road for Hitchcock & Morse the past year, has established himself at 9 Pike Block, where the repairing of watches, clocks and jewelry will receive his attention.

Seldom has so fine a class of new watches, diamonds and gold jewelry been sacrificed to the trade as are now being sold by auctioneer J. H. French, for Max Freund & Co., 8 Maiden Lane, New York. Owing to Max Freund's retirement from business and the dissolution of the partnership the firm's entire stock is being closed out.

**New Roy 12 Size**

**Waltham Cases.**

**Now on the Market.**

**S**YMMETRY, STRENGTH, BEAUTY OF FINISH, SWISS HEAD SPRINGS, GOLD DUST BANDS, EXTRA THIN.

These are points of excellence which, as a result of years of experience, we have been able to make the most of, in constructing these splendid cases. They are made for the finer class of trade, only. Leading jobbers handle Roy Solid Gold Cases. Look for this Trade-Mark in every case.



**ROY WATCH CASE CO., 21 Maiden Lane, N. Y.**

### Providence.

*All communications for this column, addressed to P. O. Box 1093, Providence, R. I., will receive prompt attention.*

William H. Luther is building a two and a half story one family house on Adelaide Ave.

Wightman & Hough Co. moved the past week from 19 Snow St. to the Kent & Stanley Building.

The mortgagee of P. H. Richardson has transferred real estate on Elton St., to the People's Trust Co. for \$2,600.

William H. Taylor, of George H. Taylor & Son, is enjoying a pleasure trip through the south, accompanied by his wife.

Elias Lederer, who has been under treatment at the Rhode Island Hospital for several weeks, was discharged therefrom the past week.

Joshua Lothrop, of Lothrop & Livesey, was tendered a complimentary ball on May day by the members of the Pawtucket Veteran Firemen's Association.

All of the tools, machinery, etc., used by the late Seamless Stock Co., of Pawtucket, in the manufacture of seamless balls have been purchased by Arnold C. Messler, Pawtucket.

E. A. Mills, formerly with A. Cooley & Co., New York, is contemplating going into the jobbing jewelry business, and was in this city the past week making preliminary arrangements.

Hon. John C. Wyman, who was recently appointed as Rhode Island Commissioner to the Mexican Exposition, has rendered a report to the Legislature of this State to the effect that he has called upon the manufacturers who would be likely to make an exhibit at the Exposition and found that they are entirely indifferent in regard to it.

There is considerable encouragement in business. In fact so confident are many of the manufacturers that they are now engaged in taking the annual account of stock and making the general overhauls and cleanups up that they usually make in July. This is being done at this time on account of the lull and the indications of returning activity in business in July. Among those shut down the past week were Williams & Payton, Wildpret & Saacke, S. C. Shurtleff, William Bens & Bros., Thornton Bros. F. I. Marcy & Co., Patt & Kern, Crees & Court, H. N. Pervear Co., Lind & Heimberger, Vernerbeck & Clase, F. A. Dunnell & Co., J. H. Collingwood & Co., Waite, Mathewson & Co., W. S. Hough, Jr. & Co., E. J. Ettlinger, Lothrop & Livesey, Albro & Co., William Smith & Co., J. T. Mauraan Mfg. Co., C. H. Cooke Co., E. A. Potter & Co., S. M. Lewis & Co.

### The Attleboros.

George W. Livsey has discharged a chattel mortgage held by Louis R. Metcalf.

The work of building an extensive addition to the Bates factory building will be commenced in a few days.

The E. Ira Richards & Co.'s jewelry manufactory shut down last Saturday night for the making of annual repairs.

Mr. and Mrs. C. S. Smith rejoiced Thursday in the birth of twins, but their joy was dashed by the death of both little ones.

The employes of R. Blackinton & Co. enjoyed an outing at Mirimishi on Wednesday. A first-class clam-bake and fish-fry were among the pleasurable features.

In order to meet a growing necessity in this community, C. E. Sandland has added to his plant on East St. a large enameling furnace for the special purpose of enameling frames of bicycles. A similar oven has been put in by A. H. Whiting.

The jewelry business in this vicinity showed some signs of improvement the past week, and at the present time manufacturers of general lines report a better trade than there has been for several months. The increase is due to Summer trade, and nearly all the orders are direct from the jobbers. The trade in watch cases has been brisk for some time.

### Canada and the Provinces.

J. F. Van Dusen has opened a repair shop in Flesherton, Ont.

A. P. Symon, Acton, Ont., has taken his brother into partnership, the firm name being Symon Bros.

L. Atkinson, New Market, Ont., is offering to compromise with his creditors at 12½ cents on the dollar.

Charles Nettleton formerly engaged with his brother in Collingwood, has opened a jewelry store in Penetanguishene, Ont.

Recent visitors in Toronto included E. W. Ross, North Bay; G. S. Edmunds, Alliston; and H. Hurchmer, Bobcaygeon, Ont.

At the annual meeting of the Canadian Manufacturers' Association held in Toronto, April 29th, W. K. McNaught, of the American Watch Case Co., was elected chairman of the Tariff Committee.

E. Scheuer, of Toronto, has just placed upon the market a large consignment of wood and ornamental mantel clocks, and regulators of French, German and Swiss manufacture. The prices are remarkably low as compared with those hitherto prevailing in the same line.

The jewelry store of L. K. Stevenson, West Unity, O., was entered by burglars last Saturday night and about a dozen watches taken, also several chains and other jewelry.

C. F. Wolters, Rochester, N. Y., who assigned, has effected a settlement with his creditors, and will resume business. An order has been granted by Judge Sutherland directing the assignee to pay out the funds in his hands to certain creditors, and to turn the remainder of the assets over to Mr. Wolters. It is stated that all of the outstanding claims, which had not been settled, were turned over to one creditor, who gave Mr. Wolters a satisfaction of that claim, thus closing up the business. The assignee has been discharged and his bondsmen released.

### New Jewelry Businesses.

Andy Myers, Springfield, Mo.

G. Anderson, Long Branch, N. J.

Ernest Wait, repair shop, Leroy, N. Y.

M. Strom, 1190 Iowa St., Dubuque, Ia.

John A. Silvey, Orange St., Media, Pa.

Koetsch & Fowler, Webster St., North Tonawanda, N. Y.

Harold Ormsby, Farmington, Me. He was formerly with E. G. Blake, that city.

Williams & Ulmer, of Philadelphia, Pa., have opened a branch store at 926 Atlantic Ave., Atlantic City, N. J.

The Graff Jewelry Co., of Denver, Col., have incorporated with a capital stock of \$10,000 in single shares of \$1.00, to deal in watches, clocks, jewelry and precious stones. The promoters are: Chas. M. Graff, N. J. Graff and Geo. A. Smith, all of Denver, Col.

### San Francisco.

M. R. Arner, of Arner & Weinschenk, has gone north.

E. A. Phelps, of Phelps & Miller, has returned from New York.

Charles Haas, of Haas & Sons, Stockton, Cal., was in town last week.

George G. Daunt, Newman, Cal., and bride (nee Preston), were in the city last week on their bridal tour.

The store of P. P. Schmidt has been bought by the San Francisco Diamond Co., and will be opened shortly.

William Gerstner, brother-in-law of Colonel Andrews, and for some time connected with the Diamond Palace, of this city, died April 28, aged 40 years.

Emil Beck who, some six weeks ago, swindled many jewelers here by forged checks purporting to come from the Stanford University, and was captured by Max M. Baden and S. L. Braverman, in their office, pleaded guilty and was sentenced to seven years in Folsom penitentiary.

The case of O. M. Campbell, the insolvent jeweler of Santa Barbara, was dismissed in the Superior Court at that place on the decision that the court has no jurisdiction. Campbell is the Petaluma jeweler who moved a valuable stock from that place to Santa Barbara last Fall, ostensibly seeking a new location. He had not been located long before attachments began to flow in and in a short time the entire stock was in the sheriff's hands. Campbell produced a bill of sale of his entire stock alleged to have been executed a month before, to his sister, Mrs. Preston, of Chicago. The validity of the transfer is questioned.

One night recently burglars entered B. H. Hill's store, Ladonia, Tex., through a rear window and stole between \$1,200 and \$1,500 worth of jewelry, watches, rings, diamonds, etc. The electric lights were burning brightly in the store all night, but the burglars pulled the curtains down and were therefore not discovered.



# The Jewelers' Circular AND HOROLOGICAL REVIEW.

PUBLISHED EVERY WEDNESDAY BY

THE JEWELERS' CIRCULAR PUB'G CO.,

189 BROADWAY, NEW YORK CITY.

A JOURNAL DEVOTED TO THE INTERESTS OF JEWELERS, WATCHMAKERS, SILVER-SMITHS, ELECTRO-PLATE MANUFACTURERS, AND ALL ENGAGED IN KINDRED BRANCHES OF INDUSTRY.

Member of the American Trade Press Association.

Our Editorial columns will contain our own opinions only, and we shall present in other columns only what we consider of interest or value to our readers. Advertising matter will not be printed as news.

Advertising rates in THE CIRCULAR are lower, considering the number of tradesmen reached by its large circulation, than in any other jewelry journal.

Notices of changes in standing advertisements must be received one week in advance; new matter can be received up to Monday.

## INFORMATION FOR SUBSCRIBERS.

### Terms of Subscription, Postage Prepaid.

	PER ANNUM.
United States and Canada, . . . . .	\$2.00
Foreign Countries in Postal Union, . . . . .	4.00
Single Copies, . . . . .	.10

New Subscribers can commence at any time.

Payments for THE CIRCULAR when sent by mail, should be made in a Post-Office Money Order, Bank Check or Draft, or an Express Money Order or Registered Letter. All postmasters are required to register letters whenever requested to do so.

Pay money only to authorized collectors having proper credentials.

**Returning Copies** Returning your paper will not enable us to discontinue it, as we cannot find your name on our books unless your address is given.

**Changing Address.** In changing address always give the old as well as the new one. Your name cannot be found on our books unless this is done.

**Discontinuances.** We will continue to send papers until there is a specific order to stop, in connection with which all arrearages must be paid; but such an order can be given at any time, to take effect at or after the expiration of the subscription. All such orders will be promptly acknowledged by mail.

**Liability.** The Courts have decided that all subscribers to Journals are responsible until arrearages are paid in full and an order to discontinue has been received by the publisher.

### THE JEWELERS' CIRCULAR IN EUROPE.

Among the Places in Europe where THE JEWELERS' CIRCULAR is on file are the following:

LONDON—First Ave. Hotel, Holborn, E. C.; Holborn Viaduct Hotel, Royal Hotel.

PARIS—Hotel de L'Athénée, Rue Scribe.

BERLIN—Deutsche Uhrmacher Zeitung, Jägerstrasse, 73.

GENEVA—Journal Suisse D'Horlogerie.

AMSTERDAM—Continental Club, Hotel Amstel.

ANTWERP—Diamond Club, Rue de Pelican.

Vol XXXII May 6, 1896. No. 14.

Every line of reading matter in THE JEWELERS' CIRCULAR, with the exception of the few brief extracts from exchanges, always properly credited, is written exclusively for this journal. Each issue of THE JEWELERS' CIRCULAR is copyrighted. Permission to quote is extended to other publications, if such quotations are properly credited.

### The New York Legislature Adjourns.

THE session of the New York Legislature has ended, and the weary lawmakers have gone to their homes. "Allah be with you!" we fancy we hear the jewelers of the State exclaim, and we echo their parting salutation. The jewelers of New York State have been greatly concerned during the session just closed, for they have expected from day to day to learn of the passage of some measure that would shake the very foundation of their rightful interests to conduct a legitimate business on honorable principles. They have had an unintermitted battle with the representatives of the departmental stores of the State who sought to nullify the objects—beneficial to the public and just to all branches of industry concerned—of the existing Sterling Silver law, and though victory crowns their efforts for the time being, it is not to be doubted that their enemies will show a strong front when the next session convenes. In this fight the part played by the Gorham Mfg. Co. is worthy of great praise. This company have taken up the cudgels for honest silverware, and the vigilance they have manifested, the activity they have exercised, the parliamentary ability they have utilized in keeping from passage by either branch of the Legislature any of the four vicious bills purported to amend, but virtually to destroy the Sterling Silver law, were worthy of the cause in which they were engaged; though the spontaneous support given them by other silversmithing firms and the jewelers in general redounds to the credit of the entire trade, as proving beyond peradventure, that its members prefer honest industry to buncombe, chicanery and fraud. The jewelers do not take it upon themselves to pose as being more virtuous than their neighbors, but they are aware that their business, as dealers in manufactures from the precious metals, is founded on the confidence of the public, and if they would succeed, their merchandise must be as represented. When they demand, therefore, that laws be enacted compelling honesty in the making of goods of precious metal, they are perhaps manifesting a form of selfishness, but it is a selfishness that is a species of positive beneficence, for the public are greatly the main gainers. The victory, however, is not yet complete. We must plan to preserve the existing law, or if there is room for improvement, improve it, and not allow it to be amended in such form that all its virtue is dissipated.

Another matter that aroused the sense of anxiety in the minds of the jewelers was the introduction in the Legislature of amendments to the Pawnbrokers' law which, if passed, would have legalized the receiving of stolen property in the form of memorandum goods. The prompt action of the New York Jewelers' Association in presenting to the Senate testimonials pointing out the evils of these amendments, will receive the applause of the trade at large, especially when it is learned that one bill was killed in committee, and that the other was killed in the Legisla-

ture on the last day of the session. The pawnbrokers of New York are a shrewd, unscrupulous lot, and possess great influence over certain politicians. They have met defeat this session, but they will "bob up serenely," though perhaps noiselessly, next session; it therefore behooves the trade to follow every detail of the proceedings of the Legislature when next it meets.

### Significance of Guarantee on Movements.

THERE has ever been in the minds of the jewelers a confused conception of the meaning of a guarantee or warrant as applied to watch movements, and it was a praiseworthy act upon the part of the Retail Jewelers' Association of Missouri when they sent to the watch manufacturing companies the following letter:

ST. LOUIS, February 7, 1896.

Gentlemen—In behalf of the members of our organization and the trade in general, I would ask you to give me at your earliest convenience a definition of the guarantee or warrant you place upon the movements of your manufacture. In addition thereto, please state at what period or date this guarantee or warrant goes into effect, and for what length of time does it continue, should these two points be covered by the same.

W. F. KEMPER,

President R. J. A. of Missouri.

The replies to the inquiry are practically the same in all cases, and the following synopsis should be kept by the retailer for the purpose of reference:

ELGIN NATIONAL WATCH CO.—Guarantee has always been that the watches are manufactured of the best material and are good timepieces. In case of repairs necessary to movements that have been in service or otherwise, the company will furnish labor to put same in order without charge. If new material is required to replace any damaged through no fault of the company, they will charge material list price for whatever is furnished. If material is to replace any originally defective, no charge is made for new material.

NEW COLUMBUS WATCH CO.—Guarantee is that their watches are made of the best material that can be procured, and they warrant watches to be the best timekeepers and most highly finished movements for the price in the market.

ROCKFORD WATCH CO.—Guarantee is that the movement is all they claim, and if it does not prove to be so, they will take it back and exchange it, either for another or make it right. The guarantee continues for one year.

ROBBINS & APPLETON.—Guarantee is that the movements of the American Waltham Watch Co. are made of the best material and upon the most approved principle, and that for any defect in material, workmanship or construction, under fair usage, the company hold themselves at all times responsible.

R. A. LOVELAND.—Guarantee that the Paillard Non-Magnetic watches are made by machinery, of the best materials, finished by skilled labor, and adjusted to temperature and positions, and contains patent non-magnetic balance and hairspring, which are uninfluenced by magnetism or humidity. For any defect in material, workmanship or time-keeping qualities, Mr Loveland holds himself responsible.

HAMILTON WATCH CO.—Guarantee is that their movements are equal, grade for grade, in material, mechanical construction, workmanship and time-keeping qualities to any watch ever put in the American market. The company guarantee against defects of any kind.

THE ILLINOIS WATCH CO.—Are always glad to give a

new movement for one that has not proved to be satisfactory

E. HOWARD WATCH & CLOCK CO.:—No specific guarantee, but guarantee that movements give entire satisfaction, which goes into effect upon the transfer of the goods.

UNITED STATES WATCH CO.:—No specific guarantee, but all defective movements shall be made good, this understanding in turn passing to the retail dealer and consumer.

SETH THOMAS CLOCK CO.: Guarantee is for one year, being calculated from the time movement leaves the manufacturers' hands.

### The Failure of Henry Tissot.

Henry Tissot, watch case maker and dealer in watches and jewelry, 51 Maiden Lane, New York, assigned Monday to Eugene A. Gerdy, giving a preference to Emile Flandrauf, for \$1,500. At Mr. Tissot's office, yesterday, it was stated that he had no statement to make as to the cause of the failure or the amount of the liabilities and assets. A creditors' meeting will be called as soon as a statement is prepared.

Mr. Tissot started in the jewelry business as a partner in the firm of F. J. Martins & Tissot, which succeeded Schwitzer & Martins Jan. 1st, 1883. The next year, Martins & Tissot dissolved, and Mr. Tissot has continued the business ever since under his own name.

### Maltby, Stevens & Curtiss Co. Changed to the Watrous Mfg. Co.

NEW HAVEN, Conn., May 4.—At the meeting this afternoon of the Maltby, Stevens & Curtiss Co., Wallingford, at which several prominent business men outside of the company were present, it was decided to organize the Watrous Mfg. Co., to succeed the Maltby, Stevens & Curtiss Co., and the following were elected officers: W. H. Watrous, Hartford, president; D. F. Maltby, Waterbury, vice-president; George D. Munson, Wallingford, treasurer; F. M. Chambers, secretary.

The directors elected are: W. H. Watrous, D. F. Maltby, Geo. D. Munson, also Franklin Farrell, Ansonia; S. J. Bryant, West Haven; Wm. N. Clark, Ansonia; W. H. Wooster, Seymour. The business will be located as before at the same factory, making the same line of goods.

## DISSOLUTION.

"MAX FREUND & CO."—Notice is hereby given that the partnership lately existing between Max Freund, Henry Freund and Louis Freund, under the firm name of "Max Freund & Co.," has this day been dissolved by limitation. Max Freund alone will sign "in liquidation."

Dated New York, May 1st, 1896.  
Max Freund,  
Henry Freund,  
Louis Freund.

DON'T FORGET THE JEWELERS' CIRCULAR PUBLISHING CO.'S BOOK LIST when in want of any technical book in the Jewelry or Kindred Trades.

## New York Notes.

F. E. Leirback has entered a judgment for \$506.76 against Chas. V. Peyn.

Simpson, Hall, Miller & Co. have filed a judgment against Solomon Davis for \$439.97.

A. Peabody, diamond importer, removed May 1st to the Lorsch building, 37 and 39 Maiden Lane.

Averbeck & Averbeck, manufacturing jewelers, are now in their new quarters, 18 Maiden Lane.

Max Freund & Co. have entered judgments against Chas. A. Pollak for \$677.30, and against Francisco Volpe for \$230.28.

New York creditors of August Jacobs, Quincy, Ill., Monday received checks in settlement of their claims, on a basis of 25 per cent.

The Stationers' Engraving Co., 98 to 102 Nassau St., have purchased the engraving and plate printing plant of the Lucas-Brown Co., 68 Beekman St.

William Wise, the well known Brooklyn jeweler, celebrated the 82d anniversary of his birth Friday. Mr. Wise was the recipient of two large baskets of roses.

Albert Feigl, manufacturer of art metal goods and lamp shades, 22 Park Place and 255 Centre St., assigned Thursday without preferences to David J. Lees.

L. H. Cohen, maker of photo frames for the jewelry trade, has removed from room 504 to more spacious quarters, room 515 Lincoln building, 1 and 3 Union Square.

The partnership of Max Freund & Co., 8 Maiden Lane, consisting of Max, Henry and Louis Freund, dissolved Thursday. Max Freund alone will sign in liquidation.

The New York Jewelers' Board of Trade last week received a check for \$900 in settlement, at 25 per cent., of the claims held by the Board against Geo. Greenzweig & Co., San Francisco, Cal.

Henry Freund and Louis Freund, formerly of Max Freund & Co., have started as jobbers of jewelry and watches at 5 and 7 Maiden Lane, under the style of Henry Freund & Bro.

The Thomas F. Brogan Co., of New York city, have been incorporated to manufacture jewelry with a capital of \$20,000. The directors are H. S. Kearney, T. F. Brogan, and J. R. Burnett, of New York city.

Max J. Lissauer, of Lissauer & Co., accompanied by his wife, will sail for Europe, May 21st, on the *Augusta Victoria*. Mr. Lissauer will be away three months and intends to visit France, Italy, Austria, Holland and England.

Kirby, Mowry and Co. have made application for membership in the New York Jewelers' Board of Trade, and in doing so have written the Board a very complimentary letter upon the result of a trial-test in the handling of a failure claim for them by the Board.

Wm. H. Ricketts, was Monday appointed by Judge Lawrence, of the Supreme Court, receiver for Silas Stuart, a former jeweler, at 2 Maiden Lane, in the suit by J. W. Block & Bro. Stuart's assignment has been set aside.

The so-called Pawnbrokers' bill, against the passage of which the New York Jewelers' Association have so strenuously fought, was killed in committee last week and the amended bill was beaten in the Legislature on the last day of the session. The Association's resolutions condemning the bill were read on the floor of the Senate.

Ludwig Nissen, of Ludwig Nissen & Co., diamond importers, 18 John St., was surprised Friday on his arrival at the office to find on his desk a large basket of American Beauty roses and lilies, with an engrossed card reading: "Presented to Ludwig Nissen, by the Boys of the office on the Occasion of his Fifteenth Anniversary in the Jewelry Business, May 1st, 1896."

The Steel-Brussel Co., silversmiths, 55 W. 16th St., whose incorporation was noted in THE CIRCULAR of April 1st, have purchased the machinery, tools, etc., of Jos. T. Chattelier, for whom Jas. Steel, jr., of this company, was formerly foreman. The company will make a line of silver goods similarly high in grade to that made by Mr. Chattelier.

The sheriff's sale of the safe and stock of A. H. Seyd & Co., Lincoln building, 1 and 3 Union Square, is advertised to take place at 10 o'clock A. M. to-morrow, at 35 Great Jones St. The sale is under an attachment obtained by the New York Jewelers' Board of Trade on claims of Unger Bros. and C. Sydney Smith. The attachment was issued about three weeks ago on the ground that Seyd had removed property to defraud creditors.

The Treasury department, a CIRCULAR reporter was informed Monday, is now considering the charges against Deputy Collector Hefferman, of Montreal, which grew out of the arrest of A. L. Strasburger on Hefferman's complaint. Collector Weed, of the Plattsburgh district, and Special Agent Crowley are conducting the investigation. Hefferman's original complaint against Strasburger and a copy of his testimony at Strasburger's examination have been sent to Washington.

New York creditors of Toppliff & Co., St. Paul, Minn., received word under date of April 21st, that L. B. Booker had purchased all the assets of Geo. R. Toppliff, with the right to continue the business under the name of Toppliff & Co. Under date of April 29th Toppliff's attorney, Jno. T. Fitzpatrick, St. Paul, notified the creditors that Toppliff had sold out the business and placed all property in his, the attorney's hands, as trustee. A meeting of the creditors has been called for May 16th in St Paul.

Thornton J. Hawthorne, a man with a number of aliases, who, with Jas. O'Neill, recently robbed jeweler Chas Turpish, Stapleton, Staten Island, was tried, convicted, and sentenced to six months in the Kings County Penitentiary, Friday last. Thornton, under the name of T. J. Day, had previously obtained a quantity of jewelry on memorandum from Wm. Downey, Downing, Keller & Co., and C. Sydney Smith, which he failed to return. A warrant on C. Sydney Smith's complaint was sworn out and taken to Staten Island, to serve in case Thornton was acquitted of the Stapleton charge.

**Arguments on the Department Stores' Demurrers.**

The argument on the demurrers interposed by the proprietors of the 12 New York department stores, to the indictments brought against them under the Sterling Silver law, came up before Judge Fitzgerald, in Part I. of the Court of General Sessions yesterday morning. Most of the defendants were represented by Frederick R. Coudert. Ex-Judge Russell appeared for Hilton, Hughes & Co.

Judge Fitzgerald opened court at 10.45 o'clock, and after a short consultation, ex-Judge Russell opened the argument. He confined his remarks to one point of the demurrer in the indictment of Hilton, Hughes & Co. He read the first and second counts of the indictment, charging the firm with selling and having in their possession for sale, a certain article stamped "sterling" which did not assay .925. He started by attacking Newton Dexter, who obtained the indictment, and the steps which brought about the indictment.

The ground of the demurrer was that the indictments did not conform to the statute or that they did not state facts sufficient to constitute a crime. It is not alleged in the indictment that the words stamped on the article indicated or denoted that the article was silver. He made a technical point upon the punctuation of the statute, and tried to show the absurdity of constructing the statute unless the denoting part was used in the indictment.

Judge Russell went into the history of the word "sterling" and said that until this statute was passed "sterling," had never had a definite meaning of .925. He quoted from old decisions to show that the word "sterling" was indefinite.

Many decisions were read by Judge Russell to support his technical point that the indictment was defective owing to the omission of a statement to the effect that the word "sterling" stamped on the article denoted that the article was .925 fine. The other points of demurrer he left for Mr. Coudert to argue.

Assistant District Attorney Geo. Gordon Battle replied to Judge Russell, contending that "sterling" has a distinct meaning, relating to silver alone.

Frederick R. Coudert then argued. His proposition was: First, that this statute is no statute, as it violates the organic law. Picking up the argument of Judge Russell he claimed the indictment is fatally defective. Under the prosecution's interpretation the sale of "Sterling" bicycles and other articles so named would be illegal. The legislature made two standards, silver and sterling silver .925, and coin silver .900. Under the law it is a fraud to sell as silver the coin of the land. He claimed that this law was confiscation pure and simple, though by indirection. He contended that the Legislature could pass no act which would make illegal the holding of articles which were legal before the passage. He founded his argument on the decision in the case of the People vs. Weinhandler, extracts from which he read, substituting the word silver for liquor as used in that decision. The gist of the decision was that the Legislature

could not confiscate by legislation that which had heretofore been lawful. The proposition Mr. Coudert laid most stress on was that this was a case of confiscation without due process of law. An artificial system, he said, by changing the meaning of an English word (sterling) made the acts of the defendants a fraud. If the law made it a misdemeanor by applying to articles stamped, branded, etc., after the passage of the act, it might be consti-

tutional, but its retroactive provisions applying to goods made before the act was passed, made it no law.

Assistant District Attorney Battle corrected some of Mr. Coudert's statements relating to the terms of the law, and called attention to the fact that the indictments were not found until a year after the law had been passed.

Judge Fitzgerald took briefs and reserved decision.

**NEW ORNAMENTS**

... IN ...

**STERLING SILVER.**

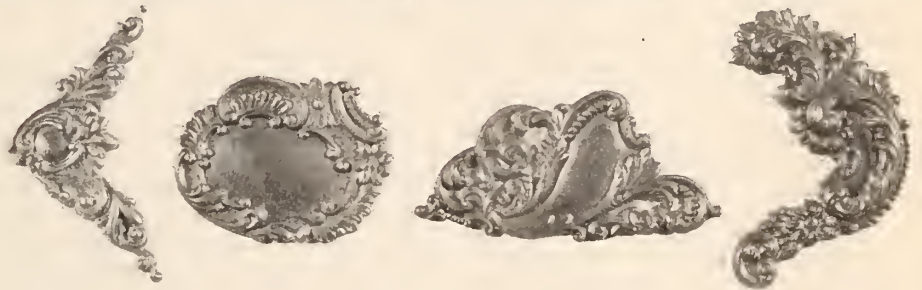

Many Designs in

**Galleries, Belt Buckles,  
Belt Slides AND Belt Fastenings,**

ALWAYS SOMETHING NEW.

**THOMAS W. LIND,**

Manufacturer of

**JEWELERS' FINDINGS.**

67 Friendship Street,

PROVIDENCE, R. I.

**SCHULZ & RUDOLPH,**

IMPORTERS AND CUTTERS OF

**DIAMONDS AND OTHER PRECIOUS STONES,**

(Successors to JOHN E. HYDE'S SONS.)

Sole Agents for The Celebrated Jules Jurgensen Watches.

28 JOHN ST. and 65 NASSAU ST., NEW YORK.

**Why not?**

put yourself in position to take orders for wedding invitations? A timely suggestion, is it not? No investment required. Simply write for our elegant sample book and terms. It will pay you.



**ALFORD & EAKINS,**

Successor to H. G. Alford.

73 Nassau St., N. Y.

## Our Traveling Representatives



Traveling representatives may consider these columns open for the publication of any news or items of interest regarding themselves or their confreres.

**T**RAVELERS in Kansas City, Mo., last week were: N. Lichtenstein, Leopold Weil & Co.; A. Marshuetz, Julius King Optical Co.; De Lancey Stone, Shafer & Douglas; M. Nason, Barbour Silver Co.; F. H. Carpenter, Alfred H. Smith & Co.; J. F. Dean and E. A. Reed, Reed & Barton.

Arthur McLean, formerly with John Sherwood, has entered the employ of J. C. Sawyer, Boston, Mass.

Traveling men calling on Davenport, Ia., jewelers the past week were: M. Berry, Larter, Elcox & Co.; W. C. Sisco, Ansonia Clock Co.; C. G. Cushman, Reed & Barton; Max Noel, Stein & Elbogen Co.

The following traveling men were in Indianapolis last week: Mr. Goldsmith, W. Porter, R. Wallace & Sons Mfg. Co.; Vic Burgess, Krementz & Co.; Mr. Goodwin, Carter, Hastings & Howe; Herbert W. Van Houten, C. Sydney Smith.

Eastern jobbers and manufacturers represented in the Twin Cities the past week were: Dennison Mfg. Co., by C. B. Osgood; E. G. Webster & Son, by C. F. Coutts; Waterbury Clock Co., by Fred L. Pattee; A. H. Bliss & Co., by J. A. Lucas; Geneva Optical Co., by Mr. Wall.

A number of traveling representatives reached Philadelphia, Pa., the past week, among them being: B. Griscom, Bippart & Co.; W. Parks, Parks Bros. & Rogers; George W. Read, Wm. B. Kerr & Co.; Thomas Tramby, Elgin National Watch Co.; James Green, O. M. Draper & Co.; J. E. Simonson, A. J. Hedges & Co.; Charles Theuser, Crane & Theuser; Fred. Lewis, Lewis, Kaiser & Luthy; Mr. Tommins, Middletown Plate Co.; Mr. Pettingill, Derby Silver Co.; Mr. Kengler, H. H. Curtis & Co., and Mr. Bliss, Bliss Bros.

Travelers visiting the Louisville, Ky., trade last week were: C. A. Culbertson, Standard Optical Co.; Mr. Herzog, Louis Kaufman & Co.; Mr. Baer, for Wm. I. Rosenfeld; Mr. Stein, Wendell Mfg. Co.; Arthur Totten, Rogers & Bro.; J. M. Morrow, American Watch Case Co.; Mr. Foster, Unger Bros.; Harry Osborne, Howard Sterling Co.; Chas. F. Ketchum, Riker Brothers; representative for Goldberg & Meyer; S. H. Van Derzer, for I. M. Berinstein; A. Peabody; Louis E. Fay, Kirby Mowry & Co.; A. Kingsland, Reeves & Sill-

cocks; Thomas H. Davis, Middletown Plate Co.; James McPhail, Edward Todd & Co.; and V. L. Burgess, Krementz & Co.

Traveling men in Boston, Mass., the past week, included: George B. Osborn, William Smith & Co.; Louis Jones, R. F. Simmons & Co.; William H. Jones, Jones & Woodland; W. C. Carrow, Mandeville, Carrow & Crane; Mr. Duffy, Enos Richardson & Co.; Joseph McClannin, Kent & Stanley Co., Ltd.; A. A. Wood, Howard Sterling Co.; Mr. Russell, L. Tannenbaum & Co.; Charles S. Isabel, L. Strasburger's Son & Co.; Leverett S. Lewis, Randel, Baremore & Billings; Mr. Kahn, Kahn & Sons; John A. Abel, Lewis, Kaiser & Luthy; Harry Ingraham; Samuel H. Brower, R. L. Griffith & Son; T. B. Wilcox, Jr., Pairpoint Mfg. Co.; H. W. Dunham, Meriden Silver Plate Co.

Among the callers on Syracuse, N. Y., jewelers the past week were: Mr. Bixby, for Frank W. Smith; Chas. B. Trewin, A. F. Towle & Son Co.; L. E.; Van Horn, Philip Zellenka & Son; C. B. Lawton, Dennison Mfg. Co.; A. W. Atwater, Jos. Fahys & Co.; Mr. Van Ness, Unger Bros.; C. F. Herdle, King & Eisele; Robert Welch, Welch & Miller; A. N. Dorchester, G. E. Luther & Co.; Harry F. Hayes, Howard Sterling Co.; W. J. Lane, Geoffroy & Co.; V. W. Henderson, Enos Richardson & Co.; Fred Clarkson, Snow & Westcott; Mr. North, Smith & North; Jacques Engel, Lissauer & Co.; A. D. Miller, the Pairpoint Mfg. Co.; R. L. Moorhead, R. L. Moorhead & Co.; Mr. Engelsman, Goodfriend Bros.; Mr. Rosensweig, Rosensweig Bros.; Mr. Mumford, Waite, Thresher Co.

Among salesmen who have called on Cleveland houses recently are: C. A. Boynton, Wm. B. Kerr & Co.; Mr. Bliss, Krementz & Co.; Mr. Carpenter, Alfred H. Smith & Co.; Mr. Morrow, American Watch Case Co.; Harry Osborne, Howard Sterling Co.; Mr. Sowade, Adolph Grinberg & Co.; J. R. Goodwin, Carter, Hastings & Howe; Mr. Smith, S. Cottle Co.; Mr. Davis, Middletown Plate Co.; Mr. Allen, for A. Wittnauer; David Kaiser, Lewis, Kaiser & Luthy; Louis Fay, Kirby, Mowry & Co.; Mr. Heiser, H. C. Hardy & Co.; S. M. Levy, L. & M. Kahn & Co.; Mr. Snedicker, Falkenau, Oppenheimer & Co.; Stephen Woods, Battin & Co.; Mr. Abbey, E. Ira Richards & Co.; W. I. Lane, Geoffroy & Co.; Mr. Smith, Holmes & Edwards Silver Co.; W. F. Clark, W. F. Cory & Bro.; C. E. Dorr, Gorham Mfg. Co.; Mr. Cook, J. F. Fradley & Co.; C. L. Joralemon, Joralemon & Ingraham, and the representatives of Alvin Mfg. Co., F. M. Whiting Co.

### Last Week's Arrivals.

The following out-of-town dealers were registered in New York during the past week: W. E. Jones, Columbus, O., Astor H.; H. L. Houghton, Boston, Mass., Astor H.; A. G. Paul, Boston, Mass., Marlborough H.; A. E. Connell, Scranton, Pa., Imperial H.; G. H. Lees, Toronto, Can., Imperial H.; A. Barber, Boston, Mass., Union Sq. H.

### Items From Here and There.

Crommelin & Williams, Chicago, have dissolved.

T. G. Calvert, Lexington, Ky., is selling out at auction.

Simon Mohr & Co., Gallipolis, O., have gone out of business.

Rodes & Maher, Santa Rosa, Cal., have dissolved partnership.

A. G. Brewer, Lamar, Miss., has sold out his stock and fixtures.

Walter Cobb, Jr., Brockton, Mass., has given a chattel mortgage for \$1,000.

Ernest C. Irish, Watertown, Mass., has been succeeded by Charles S. Robb.

An execution for \$83 has been filed against T. J. Fitzsimmons, Pittston, Pa.

A chattel mortgage given by A. H. Drews, Holstein, Ia., has been foreclosed.

The store of Fritz Dirking, San Francisco, Cal., has been attached for \$779.

J. G. McAlpine, Bakersfield, Cal., has been succeeded in business by E. W. Wright.

C. E. Phillips, Fairport, N. Y., and F. A. Butler, Gouverneur, N. Y., have sold out.

The business of the late W. A. Brown, Markdale, Ont., is being advertised for sale.

A judgment for \$100 has been entered against William F. Grassler, Williamsport, Pa.

Spinks & Bruker, Crockett, Tex., have dissolved partnership, C. Spinks continuing alone.

In a fire in Cripple Creek, Col., F. C. Hooper, jeweler, lost \$3,000; J. G. Raine, jeweler, \$4,500.

The stock of A. L. Mitchell, Halifax, Nova Scotia, has been taken possession of under a bill of sale.

The firm formerly known as R. H. Safford, Leominster, Mass., will now be known as Safford Bros.

A judgment of \$213 was entered against A. G. Zimmerman, manufacturing jeweler, Rochester, N. Y.

Otis Sleeper, Exeter, N. H., recently discharged a realty mortgage for \$1,000 in favor of A. L. Sleeper.

Penney & Ellsworth, who recently bought out Milo Putney, Ottawa, Ill., have sold the business to Fred Sanders.

Daniel F. Goodwin, Amesbury, Mass., has filed a voluntary petition in insolvency, and has liabilities of about \$5,000, offset by stock and fixtures.

Richard Noack, Norwalk, Conn., made an assignment May 1st to Attorney G. H. Vosburgh, Jr., as trustee of all his stock and personal property for the benefit of his creditors.

The stock of Jeweler Fitzsimmons was sold on April 20 at Pittston, Pa., upon an execution issued by A. Lesser's Sons, Syracuse. The whole stock was sold for \$129.50 and was bid in by Attorney Gillespie, who represented the creditors.

## Special Notices.

Rates 75c. per insertion for notices not exceeding 3 lines (25 words); additional words 2 cents each. If answers are to be forwarded, postage stamps must be enclosed. Two insertions, 15 per cent. off; three insertions, 20 per cent. off; four insertions or more, 25 per cent. off. Payable strictly in advance. Display cards on this page will be charged at \$2.00 per inch for first insertion, subject to same discount as above for subsequent insertions.

Under the heading of **Situations Wanted** on this page advertisements will be inserted for One Cent a Word each insertion, no discount. This offer refers to **Situations Wanted only**. Payable strictly in advance. If answers are to be forwarded, postage must be enclosed.

## Situations Wanted.

Notices under this heading **ONLY** are charged at one cent a word, payable strictly in advance. If answer are to be forwarded, postage must be enclosed.

**WATCHMAKER AND JEWELER**, single; 10 year's experience; have tools. References from last employer. Address 519 North St., Sydney, O.

**WATCHMAKER**, first-class, desires permanent position in or near New York or Philadelphia; best of references. Address Z., care JEWELERS' CIRCULAR.

**YOUNG MAN** 20, 6 years in wholesale jewelry line, desires position; knowledge of bookkeeping, best of references, moderate salary. Moderate, care JEWELERS' CIRCULAR.

**SITUATION WANTED**, as script, monogram or ornamental engraver and jewelry repairer; single; exceptional references from first-class houses. Address G. M., care JEWELERS' CIRCULAR.

**OPEN FOR AN ENGAGEMENT**, by a first-class watch repairer and good engraver, capable of taking charge of store; own tools, highest of reference. Address X Ray, care JEWELERS' CIRCULAR.

**A PRACTICAL WATCHMAKER** would like position; 16 years' experience on fine and complicated work; can also do French clock work; good tools. American lathe. Address Hair Spring, care JEWELERS' CIRCULAR.

**WATCH, CLOCK AND JEWELRY REPAIRER** wants a position with some good reliable party; also salesman, and capable of taking charge of store; can furnish best of references. Address R. H., 350 W. Princess St., York, Pa.

**FIRST-CLASS WATCHMAKER** (Swede) 36 years old, with 22 years experience, would like position with a good house; can furnish first-class city references; can speak English. Address G. Backlund, 182 50th St., Brooklyn, N. Y.

## Help Wanted.

**WANTED**.—First-class designer on silverware novelties. Address Silverware, care JEWELERS' CIRCULAR.

**WANTED**.—A boy or young man of two or three years' experience to do jobbing and clock repairing; references required. C. L. Haskins, Saratoga, N. Y.

**SALESMAN** visiting the jewelry trade in New York State, Philadelphia, Baltimore, Washington and the East to carry a line of mountings as a side line. Address Commission, care JEWELERS' CIRCULAR.

**WANTED**.—A persistent, experienced salesman having acquaintance with western jobbing trade, for a permanent position, to travel from the east. Established house; gold goods. State salary and reference. S. G. R., care JEWELERS' CIRCULAR.

## Business Opportunities.

\$2,200 **SPOT CASH** buys leading jewelry and optical store; established 15 years; good sized town western New York; good sales; bench work alone \$1,500 per year. Address J. O., care JEWELERS' CIRCULAR.

\$1,200 will buy my 6,800 lb. steel-lined safe, plate glass store fixtures and balance of my clocks and silverware; will sell watches and jewelry if wanted; best opening in Oklahoma for a live jeweler. Chas. E. Rose, El Reno, Oklahoma.

**FOR SALE** in Philadelphia, a desirable business in a fine locality; clean stock about \$8,000, which can be reduced if desired; walnut fixtures, fine regulator, safes, etc.; good run of work; established 12 years. Address O. E., care JEWELERS' CIRCULAR.

**FOR SALE**, on account of death of owner, an old established jewelry store, in city of 10,000 inhabitants; good clean stock and fixtures; inventory about \$9,000; great chance for the right man; terms reasonable. L. T. Tingier, Atty., Rockville, Conn.

## To Let.

**FINE OFFICE** in Decker building to sublet. Inquire at once, Room 75. Liberal concession made. 33 Union Square, N. Y.

**TO LET**—Second story of 5 and 7 Maiden Lane, New York, suitable for jewelry shop and office combined. Inquire at 5 Maiden Lane, in store.

**TO LET**.—Two upper floors suitable for diamond cutting and polishing, or jewelry manufacturing. North Light. H. Ruhnstruck, 28 Maiden Lane, corner Nassau St., N. Y.

**TO LET**—A good office on the third floor in the Diamond Exchange Building, 14 Maiden Lane, N. Y.; now occupied by the Fletcher Watch and Jewelry Co. This office will be rented very low to May 1, 1897. Apply to Janitor, or Smith & North, 14 Maiden Lane, N. Y.

## For Sale.

**FOR SALE**.—A Marvin fire-proof safe; outside width 54 inches, height 65 inches, depth 28 inches. R. A. Loveland, 177 Broadway, N. Y.

**CHEAP**—Five burglar and fire-proof safes; handsome solid black walnut glazed office partitions, tables and other fixtures; also complete set of jewelry trunks. Max Freund & Co., 8 Maiden Lane, N. Y.

## Miscellaneous

**WANTED**.—A watchmaker to hire a part of a window; rent will be exchanged for work. Apply to John Frick, 8 Liberty Place, N. Y.

## FOR RENT.

Large Office, 5th Floor - - **Corbin Building.**

Will let very low for Three Years.

APPLY, - - - -

**JOSEPH FAHYS & CO.,**  
NO. 54 MAIDEN LANE, N. Y.

**IF YOU WANT A POSITION  
YOU NEED A SALESMAN  
YOU NEED A WORKMAN  
YOU DESIRE TO EXCHANGE  
YOU WANT A PARTNER  
YOU WISH TO SELL OUT  
YOU HAVE TOOLS TO SELL  
YOU HAVE A PLACE TO LET  
YOU WANT ANYTHING**

USE THE

**SPECIAL NOTICE PAGE**

OF THE

**JEWELERS' CIRCULAR,**

Published Every Wednesday.

**WATCH** **GOLD FILLED.** **CASES**



## REMOVAL,

**IRA GODDARD,**  
WATCHES, JEWELRY  
AND DIAMONDS, TO

**CORBIN - BUILDING,**  
NO. 11 JOHN STREET, N. Y.

## TO LET

—AT—

21 Maiden Lane, (HAYS BUILD'G).

Three Fine Offices.

—INQUIRE AT—

BRUHL BROS. & CO., at Above Address.



**COMFORT AND SECURITY ARE COMBINED IN MERRITT'S PATENT EYE GLASS HOLDERS.**

Made by Merritt Cargill & Co. Springfield, Mass.

GOODS ON APPROVAL. CORRESPONDENCE SOLICITED.

## SCRIPT MONOGRAMS

Every jeweler in America should buy a copy. Illustrates and instructs how to form 2,000 script combinations. You can secure a combination in 3 minutes that you could not design in 3 hours.

ADD. WISCONSIN BUSINESS UNIVERSITY, LA CROSSE, WIS.  
PRICE 25c

**It Pays** to read a live Trade Paper.

*The Jewelers' Circular*

IS ONE.

\$2.00 a year.

STAR OF EMPIRE WESTWARD TAKES ITS WAY

# WESTERN SUPPLEMENT

## of THE JEWELERS' CIRCULAR

**Chicago Office: Room 517, Inter-Ocean Building.**

VOL. XXXII.

CHICAGO, WEDNESDAY, MAY 6, 1896.

NO. 14.

### Chicago Notes.

A. G. Schwab, Cincinnati, was a caller here the past week.

Morris Eisenstadt, St. Louis, was on the street a few days.

J. W. Forsinger returned Thursday from a week's business trip east.

Lamos & Co., formerly at 52 Madison St., moved Friday to 111 Madison St.

R. N. Blair, formerly with G. W. Marquardt & Sons, has accepted the position of salesman with M. F. Barger & Co.

Lewis A. Sawyer, an Elgin jeweler, and Miss Marie Wheepley, Olympia, Wash., were married in Chicago Wednesday.

Victor H. Kohn, of Herman Oppenheimer & Co., Kansas City, called on friends here preparatory to a pleasure visit in New York.

Mr. and Mrs. Grant Marquardt are in Des Moines, Ia., visiting parents. Miss Lillian Marquardt is visiting her brothers in this city.

Program Clock Co., of Chicago, have incorporated to manufacture program clocks; capital stock, \$100,000; incorporators, James Hegelstron, Andrew J. Reams, and Elmer E. Barrett.

Jules Racine & Co. are showing an aluminum watch for bicyclists. It is about 16 size, aluminum case, Swiss works, and has low price and lightness to recommend it for wheel purposes.

A huge vaseful of handsome flowers, the compliment and welcome of the employes of the house, greeted H. F. Hahn on his return to his desk after a sojourn since February on the Pacific coast.

The following are matters of court record for the past week. Judgments: Illinois Watch Co. vs. G. H. Sibell & Co., by default, \$515.76; Lapp & Flershem vs. A. J. Weyer, by default, \$1,729.20; Jacob Koehler vs. F. C. Spies and Frederick Klein, on verdict, \$295.70, *ex parte*.

"Our numerous lines of novelties are increasing almost daily and business is good," says J. A. Limback, representing Foster & Bailey. "Silver mounted bicycle belts for ladies are having an especially large sale and the genuine line of notions are all selling well."

Monday C. D. Peacock removed from the no. thwest corner of State and Washington Sts., where he had been for nearly a quarter of a

century, to temporary quarters one door north of his new location, northeast corner State and Adams Sts. The firm will occupy its handsome new quarters about May 11th.

The jobbing jewelers will generally close their places of business at 1 o'clock Saturdays from now till the first Saturday in September, and a few will close at 12 o'clock noon. The action is taken by the firms individually, without a petition for signatures. The silver, clock and watch houses took a similar action a week ago.

D. A. Wilkins, representing Ostby & Barton Co., with offices on 6th floor Columbus Memorial building, leaves this week for a 10 days' visit at the factory. Mr. Wilkins says his books show trade to be fully equal to, in fact a little better, than that of a year ago. Rings, he says, are staples in jewelry lines, and are less affected by outside influences than other branches.

A permit was taken out Friday for a new 10-story office building to cost \$200,000, to be built at 135-139 Wabash Ave. The building is to be erected by Benj. Allen, and is to be a brick structure. The structure will have 120 feet front, 80 feet depth, and be 130 feet in height. It will have every modern convenience for transacting commercial business, as previously stated in these columns.

Jas. H. Winn & Co., of Chicago, have incorporated with a capital stock of \$2,500, in single shares of \$25, for the manufacture and sale of all kinds of jewelry and for the conducting the business of gold and silversmiths and for the general manufacturing and sale of all articles consisting in whole or in part of precious metals; and for the dealing in diamonds, clocks, watches, etc. The promoters are: Elmer W. Adkinson, Jas. H. Winn and I. D. Belasco.

There was a crash at the Columbus building when Simons, Bro. & Co.'s heaviest safe was being taken from the elevator. The operatives attempted to roll it onto the sixth floor without first locking the elevator in position. When part of the elevator had been released the elevator sprung upward, throwing the safe to the floor with an impact estimated at 18,000 lbs. Damage was limited to mosaic floor and ceiling below, the floor girders withstanding the strain.

A quartette of diamond men made this city their headquarters the past week: A. Peabody, Sam Levy, Sam Wallace and Dave Kaiser. Mr.

Peabody sold a bill of \$11,500 in diamonds to one retail house, preparatory to Mr. Peabody's leaving for Europe. The purchasers stated that they needed stones to complete their assortment, and considered that when others were not buying was a good time to buy. They will also have the stones mounted while manufacturing jewelers are not busy.

Other tenants of 96 State St. besides Lapp & Flershem and C. D. Peacock have located as follows: J. Milhening goes to the 3d floor northeast cor. State and Adams St. with the above named firms; B. Grieshaber is at room 21, 84-90 State St., F. H. Jacobson & Co. takes room 23 at the same numbers, and W. Terrendt is located in McVicker's Theatre block. The old building is being demolished, but 12 days being allowed the contractors to have the ground clear for the construction of a modern skyscraper.

The quarters at the northwest corner State and Washington Sts., occupied for the past eight years by Lapp & Flershem, were vacated Friday and the firm are now ready for business in their new and elegant home at the northeast corner State and Adams Sts. It was an immense undertaking to pack, transport, unpack and re-install such an immense stock as is carried by this leading jewelry house, but Monday found them in position to transact business promptly at the new salesroom.

### Pittsburgh.

W. W. Wattles is spending a few weeks in Atlantic City.

Otto Heeren has been elected delegate to the National Municipal League convention, to be held at Baltimore.

Albert Grusch, the Oakland jeweler, was held for court in the sum of \$2,000. Mr. Grusch's irregular methods of doing business were lately chronicled in THE CIRCULAR.

Visiting jewelers last week were: H. C. Morrison, Mt. Pleasant, Pa.; H. H. Wehyman, Kittanning, Pa.; W. Wade, East Liverpool, O.; Mr. Baughman, Jeannette, Pa.; Adam Fisher, Greensburg, Pa.

The silver medal souvenir given at the Americus Club's dinner Monday week was the work of E. P. Roberts & Sons. The medal bore on one side a profile of Grant in relief, and on the reverse "Tenth Annual Dinner in commemoration of the birth of Gen. U. S. Grant, April 27, 1896." Each medal was encased in a neat, satin lined box.

**Kansas City.**

Mr. Benjamin has returned from an extended Kansas trip.

M. H. Alnutt, brother of L. L. Alnutt, Chillicothe, Mo., has opened a store in Trenton, Mo.

Barney Metzger has decided to locate at 6 West Ninth St., and has opened for business.

Among the out-of-town buyers here last week were: E. S. Sloane, Wamego, Kan.; B. R. Smithers, Cameron, Mo.; Herman Kinneith, Spencer, Ia.; L. Hoffman, Leavenworth, Kan.; W. P. Bond, St. Paul, Kan.; H. S. Zinn, Hutchinson, Kan.

**Indianapolis**

William Kern has opened a new repair shop in Kokomo, Ind.

J. C. Sipe has gone east to visit his brothers in Pittsburgh and Buffalo. All the Sipe boys are jewelers.

H. E. Woodward has recently taken charge of the optical department at Horace A. Comstock's store.

Edwin L. Spencer, Richmond, Ind., has filed mortgages to protect home creditors. Liabilities, \$5,000; assets not known.

Wm. Linder, formerly a member of Baldwin, Miller & Co., has gone to Central America, where he will settle on a coffee plantation.

J. F. Turner is conducting an auction sale of the entire stock of the old firm of Brooks & Dold, 104 Main St., Madison, Ind., owing to a change in the firm.

Dyer & Matsumoto, manufacturing jewelers, have dissolved partnership. George Dyer will continue the business, and for the present Ikko Matsumoto will remain with him.

What remains of the W. J. Eisele stock has been removed to room No. 25, Pembroke Arcade, where Wm. J. Eisele, as agent, will conduct a retail jewelry store for his father-in-law, Frederick Schmidt.

Eugene Von Limberg, who claims to be a foreign nobleman, has been sentenced to two years' imprisonment for stealing \$500 worth of watches and diamond rings from Jeweler Taussig, Hammond, Ind.

**Pacific Coast Notes.**

E. Meybem, Chico, Cal., is having a number of improvements made in his store.

E. S. Brown, Fullerton, Cal., has sold out his repairing outfit to a Mr. Hancock.

Ferdinand W. Griffith, optician, San Diego, Cal., has opened a new store at 909 5th St.

A. W. Hagstrom and Fred. Armbrust have started a plating establishment in Chico, Cal.

Y. H. Boudreau, formerly of Chico, Cal., has opened a jewelry establishment in the Odd Fellow building, Redding, Cal.

C. B. Griffin, San Diego, Cal., has traded his jewelry stock for land at Santa Ana, Cal.

He will continue to reside in San Diego and intend to watch repairing.

The Northwest Jewelry & Watch Co., of Portland, Ore., of which J. Jaskulek is manager, have removed from the Hamilton building to 313 Morrison St.

Mitchell Smith, jeweler, Baker City, Ore., has withdrawn from the Crystal Palace and has opened a stock of jewelry, silverware and optical goods in the St. Lawrence block.

The Empire Jewelry Co., creditors of the estate of I. J. Sharick, the absconding jeweler of Tacoma, Wash., have petitioned the Superior Court to declare their judgment of \$237.85, and the execution issued on same a first lien against the funds now in the hands of W. W. Archer, receiver. The company complain that when the sheriff levied on the secreted goods under certain writs of attachment he had petitioners' execution in his hands unsatisfied.

**Detroit.**

Fred. Blatte, the Monroe Ave. jeweler, has started a branch store out Michigan Ave.

Walter Gleason has taken charge of the jewelry store of George Chandler, Manistique, Mich.

Henry Caspary has removed from the corner of Shelby and Michigan Aves. to 267 Michigan Ave.

George Ovenshire, Bellevue, Mich., has sold his stock of jewelry to G. H. Robinson, who will continue the business there.

Wright, Kay & Co. have renewed their co-partnership, with Henry M. Wright and John Kay as general partners, and Jacob S. Farrand as special partner, who contributes \$10,000 to the capital stock.

The following Michigan country jewelers were in the city last week: M. D. Walton, Armada, A. W. Kludt, Lennox; Eugene Campbell, Pinckney; William Gribben, Carsonville; E. R. Flint, Carson City; and W. F. Carroll, Sanilac Centre.

The following traveling salesmen passed through Detroit, Mich., last week: Charles B. Bartlett, Whiting Mfg. Co.; Louis P. Cook, J. F. Fradley & Co.; F. M. Bliss, Link, Angell & Weiss; F. C. Allen, for A. Wittnauer; Mr. England, Lissauer & Co.; S. W. Abbey, E. Ira Richards & Co.; W. J. Lane, Geoffroy & Co.; L. E. Smith, M. B. Bryant & Co.; W. H. Bryant, T. G. Hawkes & Co.; L. F. Clark, W. F. Cory & Brother; John Lunn, Snow & Westcott; W. S. Manheimer, Louis Manheimer & Co., and Mr. Moorhead, R. L. Moorhead & Co.

Andrew Texley is moving his jewelry store from Newman Grove, Neb., to St. Edwards, Neb.

The jewelry store of A. H. Drews, Holstein, Ia., has been closed on a chattel mortgage.

M. Gargoura & Bro. will soon open an establishment in Albuquerque, N. M., for manufacturing Mexican jewelry.

**THE PERFECTION SHOW CASE**

FOR FINE JEWELRY TRADE.

WE CHALLENGE THE WORLD TO PRODUCE ITS EQUAL.



IF YOU ARE INTERESTED IN SHOW CASES AND JEWELRY FURNITURE, WRITE US FOR FULL INFORMATION.

**A. H. REVELL & CO.,**

431 to 437 Fifth Avenue, Chicago.

**PARSONS & SCHOOL**  
—FOR—  
**WATCHMAKERS,**  
PEORIA, ILL.  
Send for Circular and Terms,  
**PARSONS & CO.**

### Cincinnati.

Mrs. Hallie Haldman, who was arrested during the holidays for taking a ring from a tray at Frank Herschede's store, was acquitted last week, she proving that she took the jewels by mistake.

Mark Braham was last week arrested at the instance of Russell Bros. for obtaining goods under false pretenses. Mark is a son of the pawnbroker, Elias Braham, and said the goods were for his father.

C. Oskamp is putting in a new tiled floor in his large salesroom. Mr. Daller, who is the manager of the house, has been adding new improvements ever since he became the head, and the store is now one of the finest in town.

Some of the jobbers are interested in the eastern movement to form another jobbers' association as reported in THE CIRCULAR last week. The plan seems to meet with favor with the better element who are disposed to have fair business methods. It seems that since the National Association dissolved evils have been on the increase. A jobber said that one thing that ought to be corrected along with the regulation of standard prices, is the sale of watches to department stores and scheme houses, who ruin the trade. The Cincinnati contingent will no doubt fall in line, should the association be formed.

The meeting of the Cincinnati Wholesale Jewelers' Association promises to be a very interesting one, as the jobbers are stirred up very much regarding the evils existing in the trade. They are now very much exercised over the department stores selling jewelry at cut prices and educating the public to the cheaper grades. There seems to be more sales in the cheap waist sets this year than ever before, and the prices of belts have been cut to such a figure that the jewelers are discouraged. The committee appointed last month to investigate certain evils, A. G. Schwab and Harry Walton, have very interesting information to report, which will not be given to the public until certain measures as proposed are put through and pushed to a successful issue.

### St. Louis.

Trade in April, from all accounts, showed an improvement over the previous month.

H. W. Phelps, of Merrick, Walsh & Phelps Jewelry Co., left for New York the early part of last week.

W. F. Kemper has been elected a delegate to the Louisville Convention of Turners, by the West St. Louis Turn-Verein.

N. M. Parsons & Son, De Soto, Mo., have sold out, and intend locating, so it is said, somewhere in Nebraska, the exact location not having as yet been decided upon.

Among the representatives of New York diamond houses here the past week may be mentioned: Fred. Roth, L. & M. Kahn & Co.; Mr. Heiser, H. C. Hardy & Co.; and Alphonse Kahn.

Clarence White, secretary of the J. Bolland Jewelry Co., says: "March was awful dull, but April was a decided improvement. I sincerely hope May will continue the record, and we will all be feeling pretty good when the Fall trade begins."

On April 28th, the Kansas City jewelers met at the Midland Hotel and organized. Geo. P. Olmstead, of Cady & Olmstead, was elected president; J. R. Mercer, secretary; C. R. Russell, treasurer. Committees were appointed and the assemblage adjourned to meet May 7th, when a board of directors will be elected.

Herman Mauch, president of the National Retail Jewelers' Association, returned home Thursday, after attending the meeting of the Kansas Retail Jewelers' Association, which was held at the Hotel Throop, Topeka, on the 27th. He says the meeting was both large and enthusiastic, and the session was more than ordinarily interesting.

### Louisville.

E. Godshaw, who bought out Jeweler Brandenburg, Jefferson St., has canceled the trade because he found Mr. Brandenburg was in arrears for rent.

Mr. Lorch, of the Lorch Jewelry Co., is closing out his stock of silverware and clocks, and will add new fixtures to his store. He will extend his other stock, but will no longer handle clocks and silverware.

L. A. Bachus, the only jeweler who handled bicycles here, has quit dealing in them. A number of jewelers have recently received application from manufacturers to handle bicycles, but there are too many special bicycle stores.

### The Meeting of the Kansas Retail Jewelers' Association.

St. Louis, Mo., April 30.—The meeting Monday, of the Kansas Retail Jewelers' Association, was called to order by President Armstrong. Mr. Hunt acting as temporary secretary. The new officers elected for the ensuing year, as reported in THE CIRCULAR last week are: J. B. Hayden, Topeka, president; J. Q. A. Sheldon, Manhattan, vice-president; Chas. E. Wardin, Topeka, secretary; N. F. Morhouse, Topeka, treasurer; and the board of directors, J. C. Armstrong, Ottawa; Gus Burkland, Osage City; D. D. Williams, Emporia; P. Findly, Beloit, and J. Arnold, Hutchinson.

J. C. Armstrong and J. B. Hayden were elected delegates to the National Convention, with Park Findly and D. D. Williams as alternates.

The following resolutions were adopted:

*Resolved*, That it is the sense of this association that we most emphatically condemn and protest against Jobbers and Mfg'r's. sending out circulars with net prices attached in open mail.

*And let it be further resolved*, That in view of the testimony presented to the Elgin Nat'l Watch Co., by the Missouri Ass'n requesting them to rebate to the retail jewelers, it is a matter of regret that such just and equitable request was not granted.

*Resolved*, That we request jobbers to buy no goods of Mfg'r's. who sell to Department stores, and pledge ourselves to buy no goods of any Jobber who sells to anybody but regular retail jewelers.

*Whereas*, A silver stamping law such as is in force in many States should be among the statute laws of Kansas.

*Resolved*, That we, the Retail Jewelers of Kansas, do all we can to secure such a law, and call upon all legitimate jewelers in the State to aid us in securing this end.

*Be it further resolved*, That we appreciate and tender our thanks to our Nat'l President, H. Mauch, for his visit and valuable assistance to our association.

After the election of officers Herman Mauch, spoke of what the National Retail Jewelers' Association had accomplished, and his remarks were very favorably received. In the evening H. E. Duncan, assisted by Mr. Wells, gave a lecture on the "Escapement of the Waltham Watch." The lecture was attended by the jewelers and their watchmakers, the parlors of the Hotel Throop being thronged to their capacity by an appreciative audience.

Mr. Baumgartner, of the Pairpoint Mfg. Co., Mr. Hofer, of Woodstock, Hofer & Co., and Mr. Nason, of the Barbour Silver Co., did their share toward entertaining the jewelers, and their efforts were appreciated.

After making a few changes in the by-laws of the association, the meeting adjourned.

Van Moppes & Rose, 81 Nassau St., New York, recently received a large invoice of glaziers' diamonds and points of bortz for mechanical purposes.

Do you want a show case, a wall case, or an entire store fitted up? The "Perfection" show case, made by A. H. Revell & Co., 431 to 437 Fifth Ave., Chicago, is, as its name implies, the perfect product of the case maker's art. Full description of the show cases, wall cases, or interior finishings will be sent on request. The enviable high reputation of the factory has been secured by the high standard of their products maintained for many years.



**WE HAVE  
ON HAND**

A Large Number of Small

**Advertising Cuts**

Specially Designed for JEWELERS' ADVERTISING, such as above, at

**75 Cents per Electrotpe.**



SEND FOR PROOF SHEET.



**THE JEWELERS' CIRCULAR PUB. CO.,**  
189 Broadway, New York.



**News Gleanings.**

The death is reported of C. P. Smith, Henderson, Tex.

G. Teplitz has opened his new store in Duquesne, Pa.

In a fire in Dunbar, Pa., the store of Jeweler Kelly was affected.

Spinks & Bricker, Crocket, Tex., have dissolved partnership.

Chas. A. Newlon has opened a new jewelry store in Galena, Kan.

The store of T. B. Cardon, Pocatello, Idaho, has been sold to H. Dinwoody.

A. F. Robbins, Athol, Mass., has removed to another store in that town.

L. Auerbach, Minersville, Pa., has removed to a better location in that town.

James Tattersall has reopened his store at 506½ Harrison Ave., Leadville, Col.

Walter G. Adams, son of O. C. C. Adams, jeweler, Worcester, Mass., died last week.

Geo. E. Lang, late of Lang & Campbell, jewelers, Morrisville, Vt., will locate in Barre, Vt.

A. M. & Fred Scott have given a trust deed for \$400 on their jewelry business in Carthage, Mo.

The jewelry store of Noyes & Huber, Paris, Tex., was recently considerably damaged by fire.

Joe C. Wilcox, Pleasant Hill, Mo., has given a chattel mortgage on his jewelry stock for \$1,000.

Mrs. A. B. Graves is preparing to move her jewelry business from La Belle, Mo., to California.

J. M. Burkhart, Reading, Pa., held an opening of his new store, 424 and 426 Penn St., on April 27.

Otto C. Berner, Le Mars, Ia., has given a chattel mortgage for \$5,000, and has been sued for \$340.

J. H. Newell, Williamsburg, Kan., has recently paid off a real estate mortgage amounting to \$3,000.

Jeweler Scarborough, Long Island City, N. Y., has removed from Borden Ave., to 7 Jackson Ave.

H. Friedenberg & Co. have purchased the jewelry stock of Glaser & Silber, N. Main St., Asheville, N. C.

G. L. Edwards, Mt. Hope, Kan., disposed of some property recently, realising the sum of \$2,000 therefor.

James E. Betteridge, Rochester, N. Y., has removed from 72 W. Main St., to an upstairs room in the same building.

Lewis Henise, York, Pa., will shortly occupy the adjoining storeroom, in connection with that he now occupies.

The business of A. Bourgeois, Jackson, Miss., has been sold to Leonard Krower & Co., New Orleans, La., who were his largest creditors.

An inventory of the stock of the Gilreath-Durham Co.'s store, Greenville, S. C., has

been completed and the store is open for business.

Capt. Henry Lomb, of the Bausch & Lomb Optical Co., Rochester, N. Y., sailed last week for Germany to spend two months with his children.

Sulzbacher & Son, Florence, S. C., will soon move into their new jewelry store in Dargan St., which will be elegantly furnished with modern improvements.

The Hull jewelry store, Warren, O., will be re-established as soon as satisfactory arrangements can be made between Dana Hull, proprietor, and his creditors.

The jewelry store of E. E. Bates, Palmyra, N. Y., was closed April, 26 by Deputy Sheriff Collins. The goods will probably be sold at auction. Liabilities, \$2,000.

Chauncey A. Knight, jeweler, Dalton, Mass., was before the district court in Pittsfield, April 28, charged with indecent exposure, and was put under \$800 bonds.

The death occurred recently of Mrs. Dan S. Jones, wife of the well known jeweler of Independence, Ia. She was in her 41st year, and was a woman highly respected by her townspeople.

The jewelry store of J. W. Crom, Hyndman, Pa., was broken into by burglars on the night of April 25, and 30 watches were stolen, together with several diamond rings and other jewelry.

Pursuant to an order of the court, Sheriff Bowles, April 22, sold at public auction the stock of jewelry, etc., of V. J. Pekor, Columbus, Ga., who failed recently. It was bid in by C. F. Pekor for \$5,500.

The jewelry store of E. L. Spencer & Co., Richmond, Ind., closed its doors April, 28th, and filed mortgages for the benefit of local creditors, the outside creditor being left wholly unprotected. Liabilities, \$5,000; assets not given.

A new silver plate factory, of which G. W. Hill, the former secretary of the Manhattan Silver Plate Co.'s factory, Lyons, N. Y., is president, and F. W. Chamberlain is secretary, will be started in Syracuse, N. Y., about the middle of May.

W. J. McLain's jewelry store, Sigourney, Ia., was burglarized of about \$600 worth of jewelry recently. The thieves took a lot of silver watch cases, silverware, gold rings, gold pens, gold pencils, charms, etc. There is no trace of the burglars.

The residence of F. L. Shuster, jeweler, Texarkana, Tex., was entered by robbers one night recently and robbed of watches, diamonds and other valuables, aggregating about \$1,000. The thieves were discovered while at work, and made their escape through the garden.

Chancellor McGill, in Jersey City, N. J., April 27, ordered the resale of the estate of Pattberg Brothers, manufacturing jewelers. At a former sale the property was bidden in by Mayor Fagan, of the Hoboken Iron Works, but Clark & Co., of New York, the unsuccessful bidders, object that the price accepted was too low; hence the order to resell.

**COMBINATION  
PURSE AND  
GLOVE  
HOOK.**

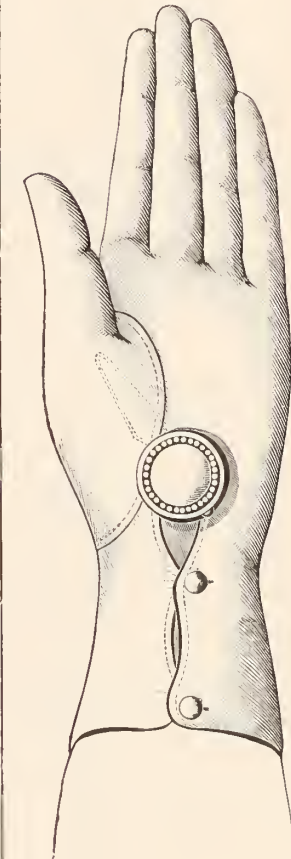
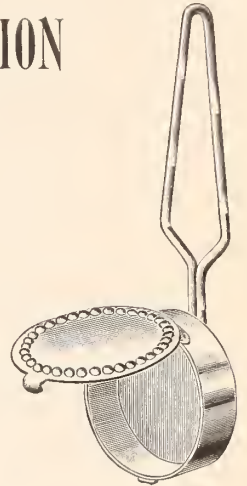

This absolutely new article is bound to have a large sale. It is extremely convenient, serves as an easily accessible carrier for small change such as is required for carfare—is securely held in the palm of the hand and saves its wearer from the insanitary practice of holding coin between the lips.



**A SPLENDID NOVELTY  
MADE IN STERLING SILVER.**



We are makers  
of Sterling  
Silverware  
Exclusively.  
All goods  
925-1000 fine.

**F. M. WHITING CO.,**  
North Attleboro,  
Mass.

# OPPENHEIMER BROS. & VEITH,

CUTTERS OF DIAMONDS,

DEALERS IN WATCHES,

65 NASSAU STREET (PRESCOTT BUILDING), NEW YORK

## HENRY FERA,

IMPORTER AND CUTTER OF

# DIAMONDS

PRESCOTT BUILDING,

65 Nassau St. cor. John NEW YORK.

FACTORY

60 Fulton St., NEW YORK.

Cutting for the Trade a Specialty,

## W.F. Evans & Sons

SOHO CLOCK FACTORY,

Handsworth, Birmingham, ENGLAND.



GRANDFATHER CLOCK.

MANUFACTURERS OF  
CHURCH,  
CHIME and  
QUARTER

## CLOCKS,

SCHOOL AND  
HOUSE CLOCKS.

With arch brass dials to chime upon  
Bells, Gongs, and Harrington's  
Patent Tubes.

ESTABLISHED 1805.

### This TRADE MARK on CUT GLASS is a GUARANTEE



of Superior Quality, Design and Workmanship and Unsurpassed Brilliancy of Cutting. Our Goods are especially desirable for the Jewelry Trade.

Send for  
Our New  
Catalogue ...

### STANDARD CUT GLASS CO.,

545-547-549 W. 22nd STREET, NEW YORK.

## ENAMELERS

OF GOLD, SILVER AND PLATED JEWELRY,

Enameled, Plain and in Colors.

ALSO OF

SOCIETY EMBLEMS,  
YACHT AND COLLEGE FLAGS.

All Varieties of Painted Enamel Work.

## S. S. WILD & SON,

179 Eddy Street, PROVIDENCE, R. I.

Correspondence Solicited.  
Telephone Connection.

## CROUCH & FITZGERALD.



Jewelry Trunks  
and Cases,

161

Broadway,  
Bet. Cortlandt and  
Liberty Sts.,

688 B'way,  
701 6th Ave.,  
NEW YORK.

### Connecticut.

H. B. Wilson, a well known Norwalk jeweler, has opened a new jewelry store at 2 S. Main St., that city.

W. H. Ingraham and family, of Bristol, who have been spending the Winter at Hamilton, Bermuda, have sailed for home.

At the quarterly meeting of the directors of the Southington Cutlery Co., Southington, April 29, no dividend was declared.

W. M. Reed, formerly with R. N. Johnquest, Ansonia, removed to Amherst, Mass., last week, where he is to engage in the jewelry business.

The German silver department of the Bristol Brass & Clock Co. is again running full time, instead of four days a week as for some time past.

The William Rogers Mfg. Co., of Hartford, furnished the silverware for the elegant new steamer *Middletown* of the Hartford & New York Transportation Co.

William W. Myatt, traveling salesman for the Meriden Britannia Co., accompanied by his wife and child, left for England April 29th. They will be absent several months.

Gen. Geo. H. Ford, president of the New Haven Chamber of Commerce, delivered the annual address before the Chamber April 28th. Gen. Ford and wife have been at Lakewood, N. J.

Simpson, Hall, Miller & Co., Wallingford, have secured a new designer for their factory. He is Emil Goetze, who has been at the Gorham works in Providence for the past two years.

Saturday afternoon, April 25, about 80 of the 100 employes of the Parker Clock Co., Meriden, were notified that their services would not be needed for some time to come. The notification was a surprise to those thrown out of work. T. F. Breeze, president and treasurer of the company, said: "Under the present condition of business, we find it inadvisable to keep on stocking up. We had to let about 80 employes go, mostly girls, as orders were coming in slowly, and we saw no prospect of any increase of business in the near future. We are stocked up as much as we desire for the present. Still, we have a working force on, getting out a new clock. We will keep on as long as possible, and will make the best of the times."

L. K. Dudley, a well-known jeweler, of Newport, Me., died last week.

## J. R. WOOD & SONS,

21 & 23 MAIDEN LANE, NEW YORK.



MANUFACTURER  
OF



PLAIN SOLID GOLD RINGS.  
SEAMLESS PLAIN SOLID GOLD RINGS  
ENGRAVED AND CHILD'S RINGS.

No Ring Stamped Different from Quality.  
Send for Catalogue and Price List.

Old Gold and Silver received and estimated on: If amount allowed does not give satisfaction, notify at once and will return at our expense, in same condition as received.

# PAILLARD = = WATCHES

ARE AS GOOD AS THE BEST.

R. A. LOVELAND, IMPORTER, 177 Broadway, New York.

## MATTERS IN JEWELRY STOREKEEPING.

That this department shall prove mutually beneficial to our readers, it is desirable that the members of the trade generally communicate with *THE CIRCULAR* regarding any advantageous device or plan that they are utilizing in connection with their business.

### A Dainty Easter Window Display.

**A**N unusual pretty Easter show window was that of the store of H. E. Floyd, Glens Falls, N. Y., a picture of which, reproduced from a photograph, is here presented. In the center of the window was a cross covered with silk and rising out of a mound of rocks overgrown with fern which

crystallized prehnite on exhibition in Joseph E. Sykes' jewelry store show window, Paterson, N. J. These specimens came from Berger's trap-rock quarry at Stony road, near the Lackawanna railroad. Many of the stones are highly polished, and resemble a species of agate and amethyst. Coal, copper and similar substances are mixed with crystals. The exhibition is an attractive feature.



A PRETTY AND APPROPRIATE EASTER WINDOW.

twined upward around the cross. At each side of the cross was an Easter lily. The flooring of the window was rumpingly covered with white cloth, while lace curtains heightened the general effect of daintiness of the display. Diamond jewelry in cases was arranged here and there on the mound of stones, while pieces of cut glass and silverware were placed in the foreground and at the sides. The show window could be accepted by jewelers as a model.

### Some Advertising Ideas in Brief.

There are some beautiful specimens of

William Hollander, watchmaker, Hotchkiss block, Middletown, Conn., has just constructed a very pretty device for his show window in the shape of an octagonal pyramid to display jewelry. By a mechanical device it is kept in continual revolution.

L. Henise, jeweler, York, Pa., has a rather novel way of advertising. Having cut his dog's hair close for the warm weather, he has inscribed his name and business on its side and back in red ink and turned it loose in the streets.

## Spring Fashions in Jewelry and Silver.

A LADY'S RAMBLES AMONG THE JEWELERS.

Jelly-slicers are obtainable in gold and in silver.

Moustache combs and brushes are mounted in Roman colored gold.

Gate purses in gold and silver are now furnished with chain and hook.

A gilding over silver, known as rose gold, is a novelty for purse and bag clasps.

The present style of dress demands for its enrichment gem-set and gold ornaments.

Personal ornaments of the Louis XIV period are faithfully delineated in modern jewelry.

New berry sets in cut glass and gilded silver are not only timely but attractive objects.

Miniature tea sets, in solid silver, are numbered with expensive toys for the modern nursery.

The new sugar and cream holders in cut glass, include several sizes and many and varying shapes.

Java lizard skin bags and purses, with mountings in the new rose gilding, are attractive objects.

Designs for the new brooches and bracelets, in which the opal figures prominently, are many and beautiful.

Very handsome is the banquet lamp standing on a silver pedestal and showing fluted columns in palatine and gold.

Silver candlesticks are more used than ever for table decoration, and their bright colored shades are an important feature.

Chatelaine bags of white seal, with filigree silver clasps, are designed with a view to meeting the requirements of the Summer girl.

Women cyclists are interested in the silver equipments furnished for their use, including clips and bar handles and oil can of decorative appearance.

It is claimed by those who ought to know that an entire toilet can be made without other assistance than that furnished in the new toilet cases for fair bicyclists.

New York women are alive to the fact that fashion decrees the wearing of jewelry, and New York jewelers are meeting the increased demand with exceedingly artistic and dainty ornaments.

ELSIE BEE.

**JOHN T. PECK,  
WATCHMAKER**

—FOR THE TRADE.—

409 WASHINGTON ST.,  
Room 15. BOSTON, MASS.

**FERD. FUCHS & BROS.**

**SILVERSMITHS.**

MAKERS OF STERLING SILVERWARE,  
808-810 Greenwich St., - New York



Send 40 Cents For sample of our steel E. G. frame with Imperial guard in Imperial case. Levy, Dreyfus & Co., Wholesale Opticians, 9-11 Maiden Lane, New York.

**PHOTO-MINIATURE.  
PORTRAITS \$1.50  
ON  
WATCHES**

The Goldstein Engraving Co.,  
1 MAIDEN LANE, NEW YORK, N. Y.

**O. NEWMAN,**

Gold and Silver Electro-Plater,  
Etruscan Coloring a Specialty.  
WATCH CASE POLISHING.

75 Nassau St., Room 8 Rear Building, New York.

**SECURITY PIN GUARD**

PAT'D DEC. 25, 1894  
MANFD BY SECURITY MFG CO. **25¢**

7 ASTOR HOUSE (BROADWAY) N.Y.

85c. doz. Net Cash. Discount to Jobbers

**WOOD & HUGHES,**

**STERLING SILVERWARE MANUFACTURERS**

New York Agents for the Derby Silver Co.,  
FINE QUADRUPLE PLATED WARE,  
No. 16 JOHN STREET, - NEW YORK  
206 Kearney St., San Francisco, Cal.  
HASKELL & MUEGGE, Agents.

SEND FOR A CIRCULAR OF OUR FRAME AND LENS

\$6.90. **CABINET.** LESS 6%.

JOS. FRIEDLANDER & BRO.,

WHOLESALE OPTICIANS,

9 MAIDEN LANE, - - NEW YORK.



**REGINA**

MUSIC BOXES

A. WOLFF,

General Agent.

LINCOLN BLDG., 14th  
St. & Union Sq. W., N.Y.

CAMPBELL-METOALF SILVER CO.,  
SILVERSMITHS,



ALL GOODS 925/1000 FINE.

Factory, Providence, R. I. Offices, New York and San Francisco.

**The Latest Patents.**

ISSUE OF APRIL 28, 1896.

558,958. STOP-WATCH. ROBERT G. JENNINGS, New York, and EDMOND KUHN, Brooklyn, N. Y., assignor to Philip B. Jennings, New York, N. Y.—Filed May 25, 1892. Serial No. 434,246. (No model.)



In a stop watch, the combination of the stop wheel and levers for revolving the same with the sweep seconds-clutch and the clutch operating mechanism consisting of the spring G, having a projection G, said spring normally tending to keep the clutch members out of engagement and the claw-shaped lever F, one arm of which acts directly upon the projection G, of spring G, so as to permit the engagement of the clutch members while the other operates the fly-back.

559,034. FOUNTAIN PEN. JAMES W. LAUGH



LIN, New Haven, Ind.—Filed May 1, 1894. Serial No. 509,690. (No model.)

559,070. CLOCK-REGULATOR. GEORGE B. WOODRUFF and THOS. W. R. McCABE, Winsted, Conn., assignors to the William L. Gilbert Clock Company, same place.—Filed Oct. 16, 1895. Serial No. 565,823. (No model.)

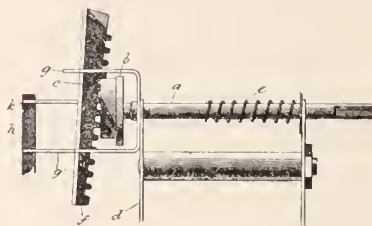

The regulator for clock pendulums herein described, consisting of the rotary shaft a, disk b, convolute c, frame d, spring e, operating upon the rotary shaft, oblique faced toothed rack f, supports gg, pendulum-support h and slotted stay k, whereby the length of the pendulum may be adjusted throughout a range commensurate with the length of the oblique-faced toothed rack-bar f.

559,183. MUSIC-BOX. WILLARD F. MAIN, Iowa City, Iowa.—Filed June 24, 1895. Serial No. 553,786. (No model.)

559,289. COMBINED NAPKIN HOLDER AND RING. HERMANN C. O. HUSS, Princeton, N. J.—Filed Nov. 5, 1895. Serial No. 568,025. (No model.)



The serviette-holder consisting of a strip of flexible material provided at each end with hooks and at an

intermediate portion of its length with retaining devices for the said hooks.

559,310. DETACHABLE HOLDER. ALEXANDER W. ROTHSCHILD, New York, N. Y.—Filed Feb. 19, 1896. Serial 579,933. (No model.)



A jewelry-suspending device of the character described, made of a continuous length of wire bent at medium point of its length and from thence upturned to compose lower loop hook the wire being continued and crossed above the loop-hook and from thence extended an opposite oblique lines the terminal at one side being finished with open eye-ring, and at the opposite side with similar eye-ring under which the wire is continuously twisted to compose end spring bow to press against the catch-hook of fastening pin of a brooch and hold the device and the brooch securely locked.

559,320. EYEGLASSES. MARTIN BERGSSJO, Chicago, Ill., assignor to Herman H. Koerts.—Filed June 5, 1894. Serial No. 513,507. (No model.)

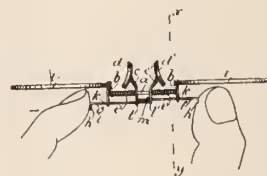

The combination with eyeglass-eyes fixedly connected by a straight bar, spring-pressed nose-piece sliding on said bar, a finger-piece to each nose-piece extended and supported beyond the opposite nose-piece.

DESIGN 25,433. HANDLE FOR SPOONS, ETC. CHARLES OSBORNE, New York, N. Y., assignor to the Whiting Manufacturing Company, same place.

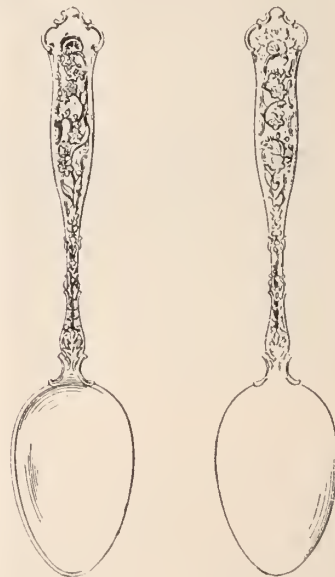

—Filed Mar. 20, 1896. Serial No. 584,181. Term of patent 7 years.

TRADEMARK 28,188. OPTICAL TOY. ADOLPH STRAUSS & Co., New York, N. Y.—Filed Jan. 20, 1895.

**Laughing Camera**

Essential feature.—The "LAUGHING CAMERA." Used since June 13, 1892.

DEPARTMENT OF  
**ADVICE AND CRITICISM**  
 ON  
**RETAIL JEWELERS' ADVERTISING.**

BY ALFRED MEYER.

[This department is absolutely free to every retail jeweler and optician. Forward for criticism your newspaper ads, booklets, catalogues, novelties, circulars, etc. Ask advice and offer suggestions. Replies in these columns are unbiased. Please make letters as brief as possible. Every letter and ad. sent will receive full attention, though the publication of the matter may sometimes be delayed a week or two. Address letters and other matters to The Jewelers' Circular Pub. Co., 189 Broadway, New York.]

PART XII.

**S**PASMODIC advertising cannot pay. Most jewelers seem to favor and follow the past century's method of advertising, that is to spend vast amounts of money during the period the public find it necessary to buy jewelry. It is true that the jeweler should use more advertising space in the height of the buying season than at any other time; however, he should not lose sight of the fact that purchasing is done, more or less, during the entire year. Success in advertising is attained only when firm and wares are kept before the public continuously in a judicious way. I do not mean to convey the idea that large spaces should be used in dull times. What I mean is this: Put an ad. in almost every issue of the best newspaper the entire year, and have each ad. contain a different one of your reasonably priced offerings.

The public may not need or want to buy the advertised goods on the day they are advertised; but the ad. may put the reader in mind of this, that or the other thing that needs repairing, and as repairing nets profit to every jeweler and often is the means of gaining a new customer, the advertising in the dull months is surely not unprofitable. Another thing: the public have more time to read advertisements in the sultry months than at the Xmas. season, and it is certain that ads. read in the sultry months are better memorized. Being in this way constantly in touch with the jeweler, the ad. cannot help but turn the reader to your store whenever he wants anything in the jeweler's line. The most successful merchant is he who advertises all the year round. The success of the department store owners has proven this to be true. Of course the percentage of returns in the dull months is far less than at the height of the seasons.

My advice to jewelers is: advertise constantly from now until

Xmas. Use small ads., very small ads., until the middle or latter part of November. Then advertise judiciously for all it is worth until Xmas. day. Let us suppose that the house I have in mind spent last year \$500 for newspaper advertising. I do not wish to go into details as to how this money was spent; but do wish to give a plan as to how this same amount should be invested this year. Spend \$36 monthly for the first eleven months of the year, and the remaining \$104 in the December weeks. \$36 a month means \$9 weekly. Use evening papers only when such are published in your city. I recommend evening papers for the reason that they reach the reader in an opportune time, after business hours or after house cleaning. Use the best Sunday paper invariably. Never advertise in the Saturday evening paper, but omit no issue during the week. From Monday to Friday inclusive, should be five advertising days; each time \$1.50 worth, and on Sunday the same, would make \$9 weekly. This would give you a good representation. To make the investment profitable, change each day's ad., offer each time a new item or suggestion with one price. Describe what you advertise thoroughly, acquaint the public with its merits and utility. Furthermore, you must make the ad. attractive, either by surrounding it with a striking border, or by leaving a white margin all around it. Conceive a certain display style, adopt it, and stick to it constantly.

A thing you should guard against is permitting the newspaper to place your small ad. among a lot of larger ones. Ask the publisher to put the ad. at the bottom of a column, near to or surrounded by reading matter. Then demand of the newspaper publisher that he publish your ad. on the same page of the paper daily.

Adopt these suggestions for one year, and you will never

diverge from them, except to increase your space in proportion to the increase of your business. Let me impress upon you once again with the fact that continuous judicious advertising brings success.

\* \* \*  
 D. C. Spalding, Wabasha, Minn., sent a leaflet titled, "Souvenir Six Art Studies from Modern Paintings." Though it says 6 art studies the leaflet contains reproductions of only 4 studies. The first is titled "A Fair Dreamer," by E. Bisson. The second, "Home Rulers," by W. H. Trood. The third, "A Brittany Shepherdess," by Lerolle, and the last "Left on Honor," by G. Igler. The reproductions are good and are printed well on heavy glazed paper. The reverse side, or the back, of each of the 4 pictures is not glazed, and has advertising matter printed on it. The printing and presswork on these backs is horrible. Even the proof reading has been carelessly performed.

On one of the pages Mr. Spaulding says: "Sterling silver novelties and clocks, good, bad and indifferent." That is anything but good.

The leaflet cover is very neatly embossed in green and gold, and at the first glance makes a good impression. Though the leaflet is not written with sufficient force to make a sale, it certainly is good policy to send out occasionally such works to customers. The public will no doubt save a leaflet like this.

Recent Good Ads.

[Under this heading will be reproduced good ads. (introductory portions only) culled from various sources]

E. P. Roberts & Sons, Pittsburgh, Pa.

We examine your

**DIAMONDS**

◆◆FREE◆◆

And if any repairs are necessary, we do it promptly at small cost.

OUR OWN FACTORY ON THE PREMISES—NO RISK. . .

... **OPALS** ...  
 Are gaining in favor rapidly—the old time superstition has passed away—gleaming with prismatic fire they are the most beautiful of all colored gems when artistically mounted as a  
**SOLITAIRE**  
 or Clustered with Diamonds.  
 All styles, all sizes, all prices.

**PEARLS!** • **MODEST LOVELINESS.**

"Orient Pearls, at random strung."

Not exactly at random, for there is much method and skill shown in our beautifully designed

**PEARL PENDANTS.**

Large variety of harmonious effects, including combinations with diamonds.

**CUT GLASS**

Flashing, sparkling like a myriad of diamonds, it is the most beautiful of all table decorations.

**NEW DESIGNS**  
**RICH CUTTINGS,**  
**LIMPID PURITY.**  
 Everything under the sun for  
**TABLE,**  
**BUFFET,**  
**TOILET.**  
 SPECIAL EXHIBIT IN ART ROOM.

"**LOVE LAUGHS AT LOCKSMITHS,**"

But not at Goldsmiths. Did you ever think how much happiness the Jeweler brings into the world in dispensing

**DIAMONDS, GOLD JEWELRY,**  
 Silver and many beautiful things that bring so much joy to donor and recipient. Our goods and prices will please you.

**Eating Soup with a Fork**

Would be just as improbable as giving a perfect luncheon or dinner with a mutilated or badly worn

... **Silver Service** ...

We have every accessory for the dining table in Sterling Silver or Silver Plate. Our styles, quality and prices are correct.

Cady & Olmstead, Kansas City, Mo.

...1870—1895...

\*\*\*\*\*

**The Diamond Has No Rival.....**

**It is Nature's Masterpiece.....**

When a husband presents his wife—or a young man his sweetheart—with a fine diamond, he has reached the climax in the way of gifts.

We have a large stock of Diamonds of high grade, both set and unset, to which we invite your inspection.

Our Optical Department is complete. Don't forget our prices for Visiting Cards. 75 Cents with and 50 Cents from Plate for 100 Cards.

**CADY & OLMSTEAD,**  
 JEWELERS AND FINE STATIONERS.

1024 and 1026 Walnut St., KANSAS CITY.

# "TRADE-MARKS OF THE JEWELRY AND KINDRED TRADES."

Copyright, 1896, by The Jewelers' Circular Publishing Co.

For seven months THE JEWELERS' CIRCULAR has had under way a work that will comprise the trade-marks of every branch of the Jewelry, Watch, Clock, Silverware, Silver Plated Ware, Optical Goods, Precious Stone, Art Pottery, Bric-à-brac, Cut Glass and cognate lines of the Jewelry Industry.

The work is now nearing completion. We consider it will be the most valuable book that has ever been issued to the Jewelry trade.

It is a work which the retailer and wholesaler will immediately appreciate.

It will be a book of constant reference, and will be consulted more perhaps than any other book issued to the trade.

It will be a book of daily use.

It will be sold at a figure that will guarantee its rapid distribution.

In addition to illustrations of the various trade-marks and the names and the addresses of the firms to whom they belong, and the class of goods to which they appertain, the work will contain other interesting and valuable information bearing upon the subject of trade-marks.

*Such a work will prove an admirable medium for advertising to the trade; we have therefore reserved a number of pages for this purpose.*

*Firms desiring to engage advertising space in this work will be furnished with further information upon application.*

Those firms who have as yet not sent electrotype, print or drawing of their trade-mark or trade-marks are requested to do so at the earliest possible moment.

THE JEWELERS' CIRCULAR PUB. CO.,  
189 BROADWAY, NEW YORK.

Members of the Trade, Manufacturers, Wholesalers and Retailers should at once place their orders for

"TRADE-MARKS OF THE JEWELRY AND KINDRED TRADES."

\$1 per copy. Bound in Cloth. Payable now or upon delivery of Book. Detach order below and forward to the Jewelers' Circular Publishing Co., 189 Broadway, New York.

ADVANCE ORDER BLANK.

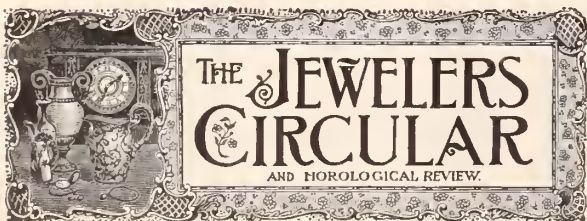

189 Broadway, New York.

.....1896.  
Please file this order for ..... copy of

"Trade-Marks of the Jewelry and Kindred Trades"

for which I agree to pay \$1.00 per copy, postage prepaid, upon delivery of book.

Name.....

Street..... City..... State.....

## Balance Springs and Isochronism.

UP to the time of Arnold, balance springs were made in the flat spiral shape. With him originated the cylindrical helical spring. The ends of this spring are bent inward, forming a curve within the circular space of the coils; the greater or lesser abruptness of these curves affects greatly the action of the spring in long and short vibrations, and is therefore determinable by the exigencies of each case.

Somewhat later the Breguet spring made its appearance, deriving its appellation from its inventor. The body of this spring is flat, but the outer coil is bent upward with a gentle sweep; at some distance from the flat part of the spring it again forms a knee downward, in order to bring its length parallel to the plane of the spring; from there it is bent inward, forming a curve gradually tending toward the center, similar to that formed by the ends of the helical spring.

Another spring is called spherical spring, on account of its form when seen sideways. It was invented by Hovivet, a Swiss watchmaker. While in the cylindrical helical spring, all the coils, except the curved ends, are of equal diameter, the diameters of all the coils of a spherical spring are different from one another, being largest in the middle and lessening toward the ends.

The specific advantages and disadvantages of these different forms of springs will be debated at some future time. The cylindrical form has, with very few exceptions, been adopted by English makers for marine and pocket chronometers, and the high reputation for superiority the English chronometer enjoys and always has enjoyed, speaks volumes in its favor. One of the principal advantages afforded by this form of spring consists in the facility with which it permits those manipulations to be performed which are necessary to enable the spring to so control the motion of the balance that the long and short vibrations are performed in equal times.

This state of uniformity is called isochronism. We find that it is practically impossible to procure equal arcs of vibration for any length of time; the gradual increase of friction will, on account of the thickening of the oil, soon make the vibrations fall off, and in the case of pocket watches, the motion imparted to the balance while being carried and the varying friction in different positions, cause a considerable fluctuation in the length of the arcs; and as, in order to obtain a steady rate of going, any given number of vibrations, whether long or short, must be performed in a given time, it is evident that isochronism is the most important feature connected with the balance springs.

A good deal has been said and written on isochronism, and where these writings have confined themselves to the practical side of the question in promulgating the results of experiments, describing the manner of pro-

cedure, the means by which isochronism can actually be obtained, they have no doubt done a great deal of good, but all endeavors to create a sound comprehensible basis for the various phenomena exhibited by different springs have proved more or less unsatisfactory.

There are those who are not satisfied simply to know what is to be done to procure isochronism, but are desirous to learn upon what principle these manipulations are based, why a change of form should procure isochronism, and why did it not exist before the change; and upon this important point it must be confessed that general knowledge is certainly deficient, not only among watchmakers, properly so called, but also among a considerable portion of those who have made springing and timing their specialty. Isochronism is a very intricate and complex topic in itself, but the difficulties in the way of mastering the subject have certainly been increased by the manner in which some writers have treated it.

When an opinion assumes the form of an authoritative dictum, without being based upon, and borne out by unmistakable facts, it is very apt to mislead the student, waste his energy, and to discourage further investigations. One of these so-called principles is the prevailing idea that isochronism solely depended upon a certain length of the spring; that too short a spring made the small vibrations slower than the long, and too long a one caused the watch to lose in long vibrations. This is so far from being correct that sometimes in the case of a very long flat spring, it is a matter of the greatest difficulty to make the long vibrations slow enough to arrive at isochronism, while a shorter spring offers more scope for any manipulation tending to that end. Everyone with some experience in timing knows that mere length has absolutely nothing to do with isochronism, and if, nevertheless, we frequently meet with this assertion in books on watchmaking it proves that it was simply copied from other books, without having been tested by the writer.

Another very general idea is that isochronism is an inherent property of the balance spring. This also is incorrect, and to assume that, because by means of the spring isochronism can be arrived at, the conditions constituting isochronism must be looked for in the spring, is not quite but nearly as wrong as if anybody was to assert that, because licorice cures cough, the conditions constituting cough must be looked for in the licorice.

**Paste or Glue for Paper Labels.**—It is said that the following preparation is very useful for making a first class mucilage for gumming large sheets of paper which may be kept on hand ready for use; when wet, they will stick well on glass: Starch, 2 drachms; white sugar, 1 ounce; gum arabic, 2 drachms; to be boiled with a sufficient quantity of water.

## Workshop Notes.

**Varnish for Brass.**—Yellow brass may be made to keep its color without appearing to be varnished by means of a thin varnish of white shellac or a coating of collodion.

**Polishing Nickel Plate.**—To brighten and polish nickel plating and prevent rust, apply rouge with a little fresh lard or lard oil on a wash leather or piece of buckskin. Rub the bright parts, using as little of the rouge and oil as possible, and wipe off with a clean rag slightly oiled. Repeat the wiping every day, and the polishing as often as needed.

**Lubricant on Oilstone.**—A correspondent says that he has used petroleum on his oilstone for the last few years, and that it serves all purposes. The stone is always clean and in working order, and those he threw aside formerly, as being too hard, serve admirably when lubricated with petroleum. He uses a mixture of two-thirds petroleum and one-third oil mixed, on his milling machine, and believes no other lubricant exceeds it in usefulness.

**To Solder Metals at Low Temperature.**—According to *Metallurgie* an alloy useful when metals are to be soldered together at low temperature can be made as follows: Copper in a fine state of division is obtained by precipitation with zinc from a solution of sulphate of copper. From 20 to 30 parts of this, according to the hardness required, are mixed in a cast iron or porcelain mortar with concentrated sulphuric acid, to which is finally added 70 parts of mercury, and the whole triturated with the pestle. The amalgam thus formed is thoroughly washed with water to remove the sulphuric acid, after which it is left untouched from ten to twelve hours, at the end of which it is hard enough to scratch lead. To use the alloy for soldering, it is warmed till it has about the consistency of wax, and in this state it is applied to the joint, to which it adheres very firmly on cooling.

**Cement for Fastening Letters, etc., to Glass, etc.**—A cement for this purpose may be composed according to the following recipes: I—Mix copal varnish, 15 parts; linseed oil varnish, 5 parts; oil of turpentine, 5 parts; glue, 5 parts. Dissolve the glue in the water bath. When the mixture has been made, 10 parts freshly slaked lime are added to it. II—Fifteen parts of varnish prepared from sandarac and white pine rosin are mixed with 5 parts of linseed oil boiled with litharge, and 5 parts of turpentine. To this mixture add 5 parts marine glue, and after this mixture has been dissolved in the water bath, add 10 parts of flake white or white lead. III—Mix 15 parts of copal varnish prepared with an addition of rosin, and 5 parts of oil of turpentine, with 3 parts of powdered isinglass; sifted iron filings, 5 parts; washed clay or ochre, 10 parts. IV—Mix 15 parts copal varnish, 5 parts linseed oil boiled with litharge, 8 parts of a solution of india-rubber in tar oil, 7 parts of tar oil with 10 parts of Roman cement and plaster-of-Paris.

IT STANDS AT THE HEAD.  
 THE LIGHT RUNNING  
**PEERLESS.**  
 THE PERFECT WHEEL.



**LIVE JEWELERS**

can make money by  
 handling our wheels.

Write for terms to Agents.

**BEAUTY — STRENGTH — SIMPLICITY.**

**THE PEERLESS MFG. CO.,**  
 CLEVELAND, OHIO.

Send Two Cent Stamp for our new Booklet,  
 "The Story of the Bicycle."

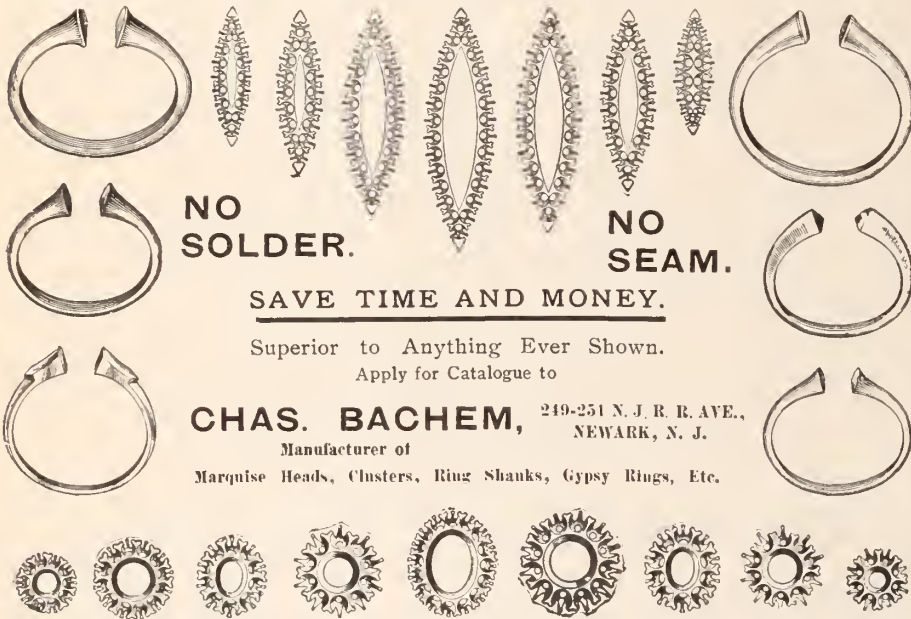

**NO  
 SOLDER.**

**NO  
 SEAM.**

**SAVE TIME AND MONEY.**

Superior to Anything Ever Shown.  
 Apply for Catalogue to

**CHAS. BACHEM,** 249-251 N. J. R. R. AVE.,  
 Newark, N. J.  
 Manufacturer of  
 Marquise Heads, Clusters, Ring Shanks, Gypsy Rings, Etc.

ESTABLISHED HALF A CENTURY.

**MARVIN'S**  
 FIRE & BURGLAR  
**SAFES**

HAVE MANY PATENTED IMPROVEMENTS  
 NOT FOUND IN OTHER MAKES  
 THAT WILL WELL REPAY AN  
**INVESTIGATION**  
 BY THOSE WHO DESIRE TO SECURE  
**THE BEST SAFE**  
 MARVIN SAFE CO.

12 PARK PLACE, NEW YORK.

**VACHERON & CONSTANTIN,**  
 GENEVA, SWITZERLAND.



FINEST QUALITY OF WATCH MOVE-  
 MENTS, FITTING ALL SIZES OF  
 AMERICAN CASES. INCLUDING



THE NEW FLAT 16 SIZE ELGIN CASES.

**EDMOND E. ROBERT,**  
 Agent for the United States and Canada.

REMOVED TO 3 MAIDEN LANE, NEW YORK.

**A. J. COMRIE,**

AUCTIONEER,  
 22 John St., N. Y.

SPECIAL SALESMAN OF WATCHES, DIAMONDS,  
 BRIC-A-BRAC, FOR ESTABLISHED JEWELERS.  
 WRITE FOR PARTICULARS.

DON'T FORGET THE JEWELERS' CIRCULAR PUB-  
 LISHING CO.'S BOOK LIST when in want of any tech-  
 nical book in the Jewelry or Kindred Trades.

**AIKIN, LAMBERT & CO.,**

MANUFACTURERS OF

FINE GOLD PENS, HOLDERS, PENCILS,  
 TOOTH PICKS, and NOVELTIES.

PAUL E. WIRT FOUNTAIN PENS, at new and lower prices . . .  
 MERCANTILE FOUNTAIN PENS, guaranteed to give satisfaction.

Catalogues with terms and discounts furnished to the trade.

BRANCH, 103 STATE STREET, - - - CHICAGO.

**AIKIN-LAMBERT JEWELRY CO.,**

IMPORTERS OF

**DIAMONDS.**

JOBBER IN

**WATCHES, JEWELRY, CHAINS,  
 NOVELTIES, ETC.**

LATEST DESIGNS.

LOWEST PRICES.

19 MAIDEN LANE, NEW YORK.





## The Rambler's Notes.

WHAT THE RAMBLER SAW AND HEARD AMONG THE DEALERS IN ART POTTERY CUT GLASS BRONZES ETC.

**CARRARA MARBLES.** VERY choice products in new Carrara marbles received by Ferd. Bing & Co., 10 Washington Place, New York, include a number of large female busts which are considered the most artistic and perfectly finished subjects ever handled by this firm. They are intended for the Fall trade.

**BRADLEY & HUBBARO'S 1898 GOODS** IN about a week the new goods of the Bradley & Hubbard Mfg. Co. for this year will be exhibited at the company's New York salesrooms, 26 and 28 Park Place. Many new finishes are promised in art metal goods which will also be shown in an assortment of entirely new styles of the celebrated "B. & H." lamps.

**LARGE ASSORTMENT OF WEDGWOOD JASPER.** WHAT is probably the most extensive assortment of the jasper ware of Josiah Wedgwood & Sons shown in New York is contained in the art pottery department of George Borgfeldt & Co.'s building, Washington Place and Greene St. The colors which this assortment shows are many, and include sage, dark and light blue, mauve, yellow, brown and black, sometimes two tints being on one piece.

The principal pieces are trays of all shapes and sizes, match safes, puff boxes, bon-bon boxes, cracker jars, pitchers, vases, urns, loving cups, cups and saucers, cigar jars, plaques and framed panels.

**NEW CUT GLASS PATTERN.** SOME new patterns in cut glass ware upon which the Empire Cut Glass Co. are now at work, will be shown in the choicest pieces this company have ever produced. The line will be especially strong in plates and bowls. One of the first of these cuttings, exhibited last week at the company's salesrooms, Para building, Church and Warren Sts., New York, is an 18 inch plate, the pattern consisting of a mass of large brilliant rosettes contained in deep cut stars. The pattern has not yet been named.

**NEW IDEA IN CLOCKS.** A NOVEL idea in clocks which satisfies the prevailing craze for blue consists of a movement set in a Flemish vase, urn or ewer. The vase, which acts as the case, is in the style and shape common to Flemish ware, the clock being set in the center of the flat side. The assortment shown by Bawo & Dotter, 30 Barclay St., New York, contains not only vase clocks of many sizes and shapes, but also clocks set in blue Flemish cases of the ordinary forms.

**DROP IN THE PRICE OF CLOISONNE GOODS.** THE gradual drop in the price of Japanese cloisonné during the past six months, has brought within the means of the larger number of the jewelers' customers many choice pieces which have heretofore been too expensive for general sale. The reduction in the assortment shown by A. A. Vantine & Co. at their wholesale warerooms, 18, 20 and 22 E. 18th St., New York, has been about 50 per cent., and applies to all varieties of articles, from the very large pieces such as jardinières, to the small and inexpensive novelties.

THE RAMBLER.

## Indian Model Wares.

LOUIS C. G. LAWTON, a native of Providence, but who is well known in Calcutta and other sections of India, has just returned to America with a marvelous collection of Indian model wares. The entire collection, comprising 1,008 pieces, were consigned to the Tilden-Thurber Co., Providence. The collection was also on exhibition at the establishment of Shreve, Crump & Low Co., Boston, Mass. The beautiful, costly and unique articles which he brought back with him represent the highest degree of art in their respective lines. It is said that such an extensive assortment of Indian models, representing Indian character in all the various castes, trades, servants and people of the country, never was exhibited in the United States. The next largest display of its kind was at the World's Fair, and consisted of 500 pieces, sent by the Indian government.

Mr. Lawton has twice dwelt for a long period of time in the far eastern countries. His headquarters during his last stay were at

Calcutta, from which city he made excursions into the interior in quest of odd and rare articles. He speaks the language of the land like a native, for it is absolutely necessary for European and American merchants to be able to converse with the native tradespeople in their own tongue, if they expect to get ahead. The models, of which the collection is very largely composed, are in their entirety the work of the famous Brahmin sculptor, Bawdoss, of Delhi, and his family. Bawdoss's household, not including the wife and the mother, consists of the sculptor's father and brother, and three sons, whose ages are 7, 14 and 18. Each of these six persons fashions the little character models, which are made of the celebrated Delhi clay, properly touched up with paints and stains so as to give the work the appropriate coloring, rendering the models absolutely true to life.

Bawdoss himself is, of course, the star and shining light of his little family group. His individual clay modeling is much sought and highly prized by connoisseurs of art. His petite figures of true Indian character are full of lifelike expression, and the lover of art cannot but become fascinated with the unique images, even though he does not admire some of the subjects Bawdoss has selected for his illustrations. The facial expressions of his little figures are full of meaning and life. For instance, there is Bawdoss's exposition of the familiar leper of India. This particular figure is not one which the average American citizen would care to place upon his sitting room mantelpiece. There is nothing lovely nor ornamental about the work. The piece includes two parts. First comes a young girl with a doleful face. She is drawing a poverty stricken cart in which reclines the form of a man apparently in the last stages of that dreadful disease, leprosy. A look of woe-begone intensity, care and age shrouds the face. The head dangles from the shoulder in a listless sort of way, and the body is devoid of aught else save skin and bones. Altogether this leper is an awful reminder of the ravages wrought by the disease, and is not a pretty thing to look at, yet at the same time the critic is impressed with its pronounced naturalness. Every line in the face tells a story by itself.

Other articles in the collection give great pleasure to view. There is the Mohammedan dancing girl with her showy raiment, and her sister of Hindostan, both of whom are attract-

ive and possess rather pretty faces. Many types of Indian character are included in the display; the typical Afghans, Beluchis, Burmese, Madrasse, Punjabis, Delhis, Bengalese, Parsees, Jains, and Cashmeres, representing all castes of different sections of India. An array of prominent gods worshipped by the natives is included in the collection, and is, indeed, one of its most interesting and fascinating features. The originals of these gods are kept in the temples, and little miniatures are made of them for the people to worship in private at their homes. Some of the models of the god images brought home by Mr. Lawton are those of Ganeza, Siva, Brahma, Vishnu, Anapurna, Lachmi, Juggernaut, Krishnu, and others.

The collection has been much depleted since Mr. Lawton's return to America, many of the better class of jewelers having made selections from it.

#### The Causes of the Depressed Condition of the Waterbury Watch Trade.

A. O. Jennings, secretary of the Waterbury Watch Co., Waterbury, Conn., in an interview with a local reporter a week or so ago, said some very interesting things in respect to the condition of the watch trade.

"The Watch company," he said, "has had a very large trade with Australia—a trade that has usually been continually increasing. Now, however, that country is passing through a series of calamities which have occasioned a vast amount of suffering there. They have had droughts and floods

and earthquakes, and now an epidemic of typhoid fever is raging. Their greatest suffering has been caused by the intense heat there during the present Summer—our Winter being their Summer. Loss of life was also reported.

"Charles O. Kemp, of Sydney, New South Wales, a merchant who has handled our goods quite extensively, called on me last Thursday. He gave a most vivid account of the suffering caused by the heat. According to his account it was something terrible. The thermometer is said to have registered 170 degrees in some places. Nearly all vegetation was destroyed. Birds dropped down out of the trees dead, and large numbers of cattle died in the fields. The heat was so intense that it melted the honeycomb in the beehives, thus smothering the bees. Many aviaries were lost in this way. At the present time the springs and wells are all dried up, and an epidemic of typhoid fever is breaking out. The suffering has been horrible, and it will probably be some time before the details are published."

In regard to the business situation Mr. Jennings said: "1896, so far, has been the worst business year we ever experienced, 1893 and 1894 are not to be compared to it. There seems to have been an accumulation of misfortune and trouble all over the world. Everything seems to have gone wrong, and there appears to be an utter lack of confidence in all countries. We had a large trade with South Africa. The recent

troubles there have almost entirely destroyed that. The trouble in Egypt has seriously crippled our trade in that country. In the United States buying is very slow. A little more can be said of the European trade. The three months' trip I took through Europe recently is resulting very satisfactorily. The Swiss are our principal competitors in the manufacture of low priced watches. We have been very successful in competing with them thus far.

"At the beginning of the present year we endeavored to keep running with our full force of employes in the hope that something favorable might happen. Toward the end of January, however, it was apparent that there was no use accumulating a large amount of manufactured goods. At that time we were running with 500 employes and turning out 1,500 to 1,800 watches per day. The number of employes was cut down to 290. About a thousand watches per day are now being manufactured, all of them of the low priced variety. We are doing very little high priced work at present.

"This enforced cutting down of the number of our employes is with us a very serious matter. The help is all skilled. We have to train them to do particular kinds of work and it is a long, hard job for us. When these dull times came on we were in splendid working condition. We hope to be able to ride over the present hardships, however, and go back to work with our full quota of help as soon as business revives."

# BAWO & DOTTER BULLETIN

## HALL CLOCKS==CHIMING CLOCKS.

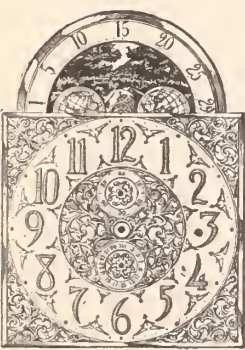

GILT ENGRAVED ORNAMENTS RAISED FIGURES—DIAL 4234

New Cases now ready—made of oak or mahogany—carved inlaid or trimmed with bronze ornaments—in a great variety of new and beautiful designs. All our cases are made in this country and the material, workmanship and finish is unequalled. **MOVEMENTS**—Elliot's automatic chimes, on musical bars or gongs—Elliot's gong chiming movements with 5 or 9 gongs, and with and without the 8 cup bells, etc.

English recoil and dead beat, hour and half strike, weight movements with beautiful dials.

B. & D.'s new weight movement.

A LARGER OR BETTER STOCK CANNOT BE FOUND.

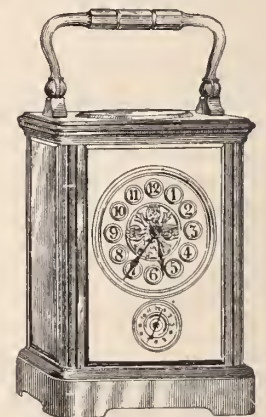

TRAVELING CLOCKS.

Large stock on hand.  
Timers—Strikers—Repeaters—  
¼ Strikers.

# BAWO & DOTTER,

Manufacturers, Importers and  
Commission Merchants,

26, 28, 30 and 32 BARCLAY ST., NEW YORK.

# “Apparel oft proclaims the man.”



HOLYOKE, MASS., U. S. A.

CHOICE PAPERS

So with our fine note papers, envelopes and papeteries—all our bands, boxes and labels are neat, tasty and artistic and perfectly in keeping with and a credit to the high grade goods with which they are used. Our fashionable stationery is put up in a manner that appeals to people of refined tastes, and it is a line particularly adapted for jewelers. We **do not** sell to dry goods or department stores. Write for samples.

**PARSONS & GREENE Co.,**  
 MANUFACTURING STATIONERS,  
 HOLYOKE, MASS.

## THE SWAN FOUNTAIN PEN

Reputation World Wide  
 Made upon Distinct Principles.  
 Is a Compressed Air Pump.  
 Simply Wet the Insides to Provoke  
 an Energy.

W. W. Stewart, Inventor and Patentee.

A variety of Styles and Prices

- 3 Sizes Safety Swans.
- 3 Sizes Self-filling Swans.
- 3 Sizes Adjustable Swans.

MABIE, TODD & BARD,

NEW YORK AND LONDON.

## AMERICAN WATCH TOOL CO.

ESTABLISHED 1872.  
 INCORPORATED 1894.

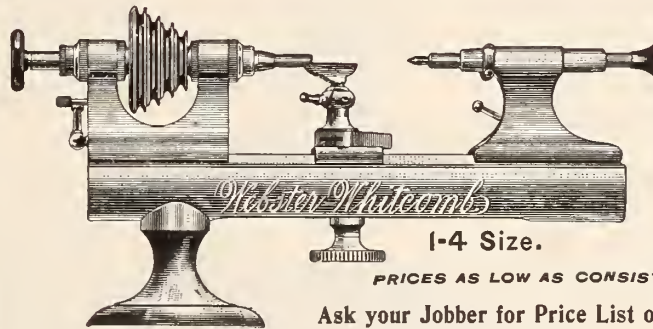

THE  
**Webster-Whitcomb**

1-4 Size.

GROWS IN POPULARITY

PRICES AS LOW AS CONSISTENT WITH QUALITY.

Ask your Jobber for Price List of 1895, or write to us at

Stoney - Batter Works, Chymistry Dist., Waltham, Mass.



THE QUESTION ?  
 WILL IT TARNISH ? Need  
not be asked if your Tissue Paper bears  
 this label.

MANUFACTURED BY

**C. H. Dexter & Sons,**  
 WINDSOR LOCKS, CONN.

◁ BE SURE YOU GET THIS BRAND ▷

It has been adopted and is now used by the leading manufacturers of this country.

CYCLING PROGRESS  
EXEMPLIFIED.

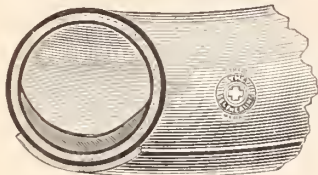

**THE WONDERFUL  
SELF-HEALING TIRES**

are single tube, finest rubber, finest wove Sea Island cotton fibre, re-enforced inside and outside on tread, and no better tire can possibly be made. They are fully guaranteed against all climatic changes, are the most resilient ever made, and when punctured instantly heal the wound of their own valtion.

THEY WEIGH NO MORE THAN OTHERS,  
COST NO MORE,  
AND ARE WORTH TEN TIMES MORE.  
— SEND FOR TIRE BOOKLET. —

Wm. H. CAHN, GENERAL MANAGER,  
48 and 50 Maiden Lane, New York.

BY EVERY TEST THEY ARE THE BEST.  
THE UNIVERSAL FAVORITES.



SUPERB  
**Olympic**  
BICYCLES

For sale by more than 2,000 Jewelers, and constructed to meet the demand for finest quality.

— For ADULTS and JUVENILES. —

SEND FOR EXQUISITE CATALOGUE.

Top Grade "Olympics" have SELF-HEALING TIRES.

Olympic Cycle Mfg. Co.,  
N. Y. Office: 35 LIBERTY STREET.

General Jobbing Ag'ts, S. F. MYERS & CO.,  
WHOLESALE JEWELERS, Myer's Building, New York.

**CHAS. JACQUES**

CLOCK  
CO.,

22 Cortlandt St.  
NEW YORK.



Hall Clocks,  
Traveling Clocks,  
Gilt Clocks,  
Porcelain Clocks,  
Delft Clocks,  
Mantel Chime  
Clocks,  
Bronzes,  
Sevres Vases.

**BAWO & DOTTER,**

26-32 BARCLAY ST.,  
NEW YORK.

P. O. Box 1872.

NO LARGER STOCK  
OF

**HALL  
CLOCKS**

IS SHOWN IN  
THIS CITY.

Large Stock  
OF  
MOVEMENTS.

NEW DESIGNS  
IN CASES.

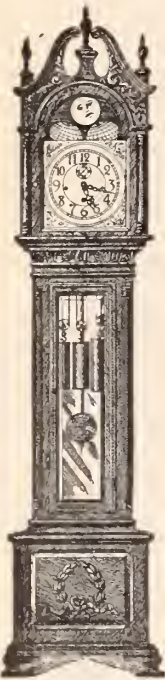

**STERLING**

Sheet and Wire Supplied. All Sizes.

**J. SCHAWEL & CO.,**

Gold, Silver and Platinum Refiners,  
29 JOHN STREET, NEW YORK.



**S. A. BOYLE & CO.,  
JEWELRY AUCTIONEERS.**

We Pay All Our Own Expenses.

WRITE FOR PARTICULARS.

54 Maiden Lane,  
NEW YORK.

413 E. Baltimore St.  
BALTIMORE, MD.



**44 YEARS OF  
HONEST RETURNS**

IS OUR GUARANTEE OF SATISFACTION  
TO ALL OUR CUSTOMERS.

WE DO OUR OWN SMELTING,

**JOHN AUSTIN & SON,**  
ASSAYERS, REFINERS AND SMELTERS,  
74 & 76 Clifford St., Providence, R. I.



**SOLID GOLD CASES**

ARE ALL STAMPED WITH THIS  
TRADE MARK AND WARRANTED BY

**THE ROY WATCH CASE CO.**

**JACOT & SON,**  
Importers and Manufacturers of  
**Musical Boxes,**  
39 Union Square, New York.

**QUICK SELLERS.....**  
IN STERLING SILVER  
ARE MADE BY  
**CODDING BROS. & HEILBORN,**  
North Attleboro, Mass.

**DUBOIS WATCH CASE CO.**

TRADE MARK REGISTERED.

FINE HAND MADE  
**SOLID GOLD CASES.**  
A PRIDE TO THE MAKER,  
DEALER & WEARER.

**WE WILL CONTINUE TO MANUFACTURE**

Our Fine Mountings at our present location No. 11 Maiden Lane, New York, till May 1st, 1897 when the buildings are to be removed.

**HENRYE. OPPENHEIMER & CO,** OFFICE: 14 MAIDEN LANE, NEW YORK.

**DIAMONDS** and Cutters. **L. & M. KAHN & CO.,** 172 Broadway, Cor. Maiden Lane, N. Y. **DIAMONDS**

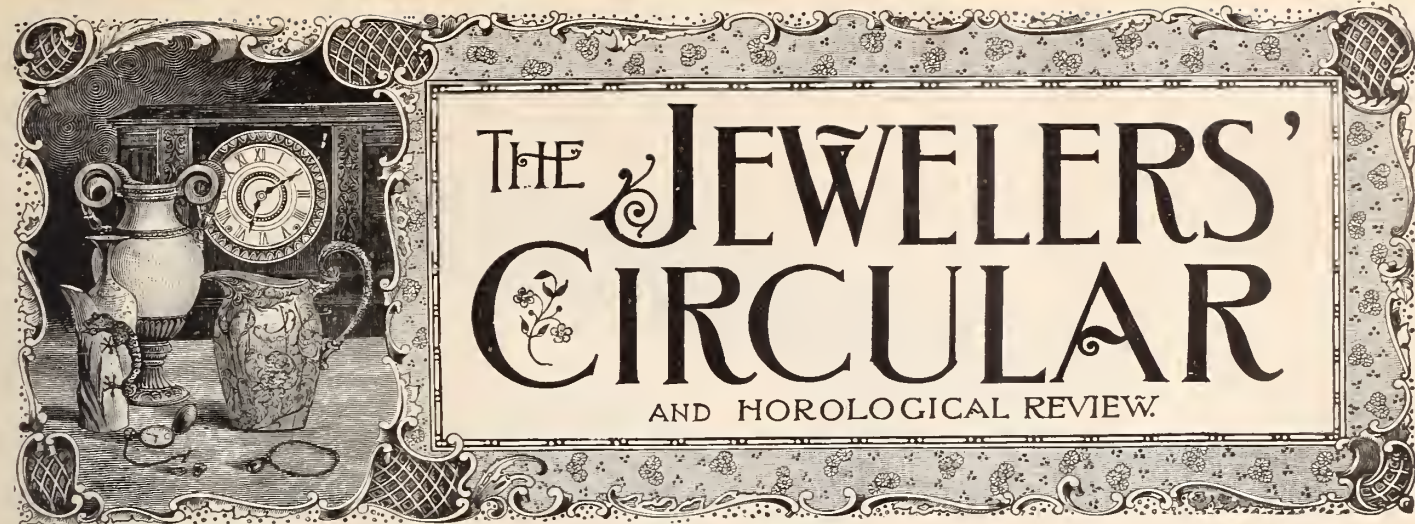

Copyright by THE JEWELERS' CIRCULAR PUB. Co.

189 Broadway, New York.

Entered at the Post Office in N. Y. as second-class matter.

VOL. XXXII.

NEW YORK, WEDNESDAY, MAY 13, 1896.

No. 15.

THE SILVER SERVICE TO THE "CITY OF NASHVILLE."

ON this and following pages are presented illustrations of Haywood P. Norman's original designs for the silver punch service which the citizens of Nashville will present to the gunboat *Nashville*, in recognition of the distinguished honor conferred upon the fair city by the Navy Department. These designs were submitted by the B. H. Stief Jewelry Co., through their manager, James B. Carr. The award was made to this firm in competition with eight other sets of designs. The service is to consist of 27 pieces of silver, namely: a punch bowl, a waiter, a punch ladle and 24 cups. They are to be of solid silver, and the aggregate weight will be about 700 ounces. The service will be presented in a handsome plush lined case of Tennessee oak. The capacity of the bowl will be three and a half gallons. The cost of the whole service will be \$1,750, of which \$1,500 has already been raised by subscription from Nashville's citizens. The design carries out the idea of the purpose for which the set is to be used, everything being associated with the sea and things seafaring. Sea shells and sea weed will form the lighter ornamentation, and this will be sustained by the use of dolphins in the heavier details, the range of the dolphins forming the base of the bowl.

In addition there will be four distinctive designs upon the bowl; first, the inscription, showing that it is the gift of the citizens of Nashville to the *City of Nashville*; second, the seal of the navy; third, the seal of Tennessee, and fourth, the seal of the city of Nashville. The general idea of the design upon the bowl will be carried out in modified form upon the other pieces of the service.

of the provincial towns when she was touring. Her diamonds, however, were not to be compared with those of the modern actresses and opera singers, at the head of whom is Mme. Patti, who, as every one knows, lately wore in the third act of the "Traviata." a dress covered with precious stones of the value of £200,000. These stones are now in Paris to be reset in the shape of a tulip-like corselet,

formed of seven leaves, from which the mousseline do-soie bodice will emerge all in fluffs and puffs. The rubies have been spared to compose a big rose mount for a long hairpin, and destined, it appears, to be placed behind the ear under the flat bandeaux à l'Espagnole, for a new pantomime in which the diva intends to appear as *Habenera*.

After Mme. Patti and, perhaps, Mlle.

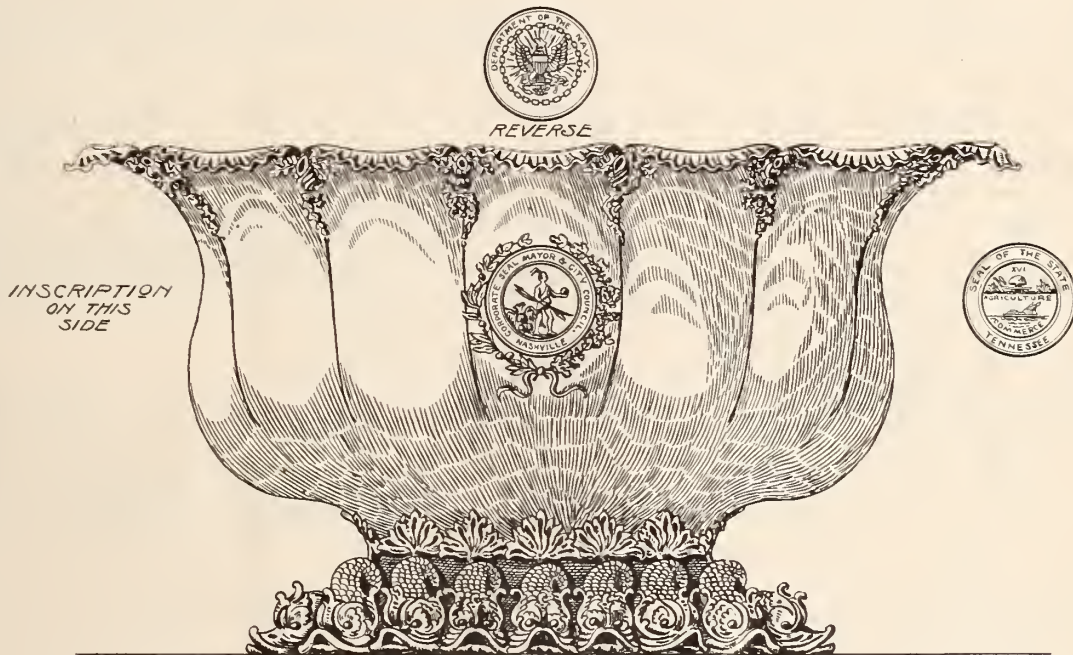

PUNCH BOWL OF THE SERVICE DESIGNED FOR "CITY OF NASHVILLE."

Jewels on The French Stage.

PARISIANS are at present gathering around theatrical playbills, where, to their intense amusement, they read the following notice: "Mlle. Aimée will appear at the Scala, wearing all her diamonds!" These announcements are not quite a new invention though, for Mlle. Mars, the great tragedienne, never forgot to placard the same sentence on the walls

Aimée, whom nobody has yet seen, and now that the belle Otero dazzles the boyards, the most beautiful stones to be seen on the Parisian stage are the emeralds of Mlle. Tholer of the Comédie Française, a vaporous blonde, whose favorite color is sky blue; the belt which encircles her waist is studded with them; one end of it falls straight in front, and ends with a fringe of tiny diamonds. This belt is particularly celebrated. The value of Mlle. Tholer's emeralds is so great that she has a policeman

**Q**RE always of **Standard Quality**, of **Newest Styles** and **Best Finish**.

They will always sell when anything will, and cost no more than those of doubtful reputation.

Don't wait for our travelers, but send direct to



**Oldest Ring Makers in America.**

**M. B. BRYANT & CO.,** 10 Maiden Lane N. Y.

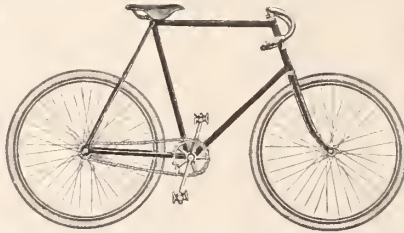
<p>IT STANDS AT THE HEAD. THE LIGHT RUNNING <b>PEERLESS.</b> THE PERFECT WHEEL.</p>		<p><b>LIVE JEWELERS</b> can make money by handling our wheels. Write for terms to Agents.</p>
<p><b>BEAUTY — STRENGTH — SIMPLICITY.</b></p>		
<p><b>THE PEERLESS MFG. CO.,</b> CLEVELAND, OHIO.</p>		<p>Send Two Cent Stamp for our new Booklet, "The Story of the Bicycle."</p>



Waverley

**BICYCLES.**

\*  
\$85.00  
\*

**AMERICA'S FAVORITES**

**Are built in the largest and best equipped factory in the world.**

No bicycle made stands so high in the estimation of riders and dealers. The cause is plain, **Waverleys** are built on honest value lines, and purchasers receive full value for their investment. **Waverleys** are the most popular and best selling wheels made, and dealers who are looking for a line with which they can command the bulk of the business, will serve their interests well by writing at once for catalogue and discounts.

**INDIANA BICYCLE COMPANY,**

General Office and Factory,  
Indianapolis, Ind.

Eastern Wholesale Branch,  
339 Broadway, New York City.

# NEW ORNAMENTS

. . . IN . . .

## STERLING SILVER.



Many Designs in

Galleries, Belt Buckles,  
Belt Slides **AND** Belt Fastenings,

ALWAYS SOMETHING NEW.

### THOMAS W. LIND,

Manufacturer of  
JEWELERS' FINDINGS.

67 Friendship Street,  
PROVIDENCE, R. I.

# Buy "The Best"

THE  
"Dueber  
Special"  
BICYCLE.

MAYSVILLE, KY., April 24, 1896.

Dueber Watch Case Mfg. Co., Canton, O.

Dear Sirs: The wheel came all right, and in fact exceeds my expectations. I have ridden the different high grade wheels for twenty years, and find this the easiest running wheel I have ever been on. Yours,

JOHN BALLENGER.

CHICAGO, ILL., April 23, 1896.

Dueber Watch Works, Canton, O.

Gentlemen: After a careful and critical examination of the "Dueber Special" Bicycle, I have no hesitancy in recommending it as a first-class wheel in every respect and I consider it the best wheel I have ever seen. The extreme care bestowed upon the fitting and finish of all parts, will alone recommend it to the watch making fraternity, who as a rule, are critical in these respects. The "Dueber Special" ranks with, if it does not surpass the highest grade wheels on the market. I see no reason why it should not have an enormous sale.

Very respectfully,

GEO. K. HAZLITT.



# Standard Sterling Silver Goods.

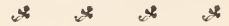

### Belts,

LEATHER, GILT,  
SILVER AND  
SILK WEBBING.

### Waist Sets,

Sleeve Links,  
Hat Pins,

IN

Sterling Silver

AND

Rolled Gold Plate.

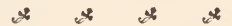

600 Useful Articles

IN

## Sterling Silver.



# Foster & Bailey,

Providence, R. I.

NEW YORK,  
SAMPLES ONLY

CHICAGO,  
SAMPLES ONLY.

"specially attached," and he never loses sight of her when she acts.

Many years ago, when Mme. Blanche Pierson appeared in the part of *Mme. de Terremonde* in the "Princess George," curious to say, there was just then living in Paris a real Prince George, who had put at her feet a casket full of marvelous gems. She hesitated about the dress she was going to wear and cover with £40,000 worth of diamonds. At last she chose the toilet in which she was painted by Carolus Duran, black faille covered with Chantilly lace; on the left side with a quille of green velvet, on which was a cascade of roses, the heart of each being a diamond. The bodice was simply smothered with the same stones, and it is said that the Empress Eugenie at the sight of that blonde beauty so dazzling, could not help frowning and saying: "Oh, what a scandal!" But Blanche Pierson enjoyed the great honor of having her dress copied almost exactly for the coquettish sovereign, who had most of the crown diamonds broken up for the purpose. Mme. Gudie is another star, in the full sense of the word, for she loves to blind her admirers, and she wore at an at-home at the Princess Mathilde's a shoulder belt, coming from the left shoulder, crossing her chest, and continuing down to her right hip, composed of diamonds, decreasing in size, the top ones being enormous, and twelve in a row.

Mme. Marie Magnier, of the *Gymnase*, has the two largest diamonds now in Paris, and this is how she got them: One day she re-

5 to-night the 100,000 francs which I ask for them?" The belle Magnier was startled. "Hum, ma bonne femme," she said, in her brusque manner, "you are very cool over the matter; you ask for 100,000 francs just as you

and flowers of all colors, formed with emeralds, sapphires, amethysts and turquoises tremble and move at the end of flexible silver stems; it is worth 200,000 francs, and was after her own design. It looks beautiful

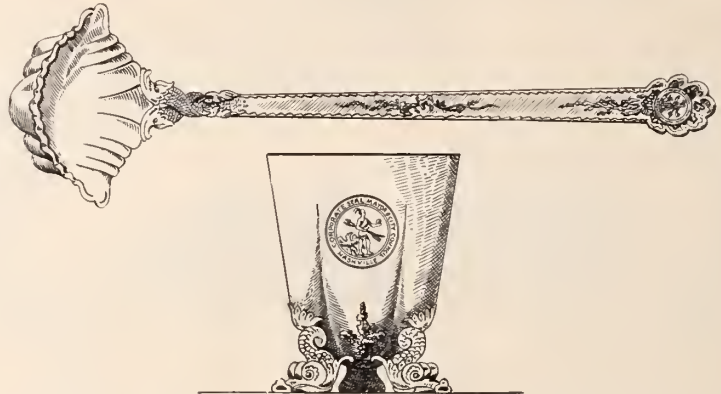

PUNCH LADLE AND CUP OF SERVICE TO "CITY OF NASHVILLE."—See Page 1.

would ask for bushel of onions." The jeweler put his fingers on his lips and nodded deprecatingly. "Oh, very well," said Magnier, "if she is a queen." "She is a queen," answered the lady proudly, shutting the case with a clap. But Magnier had been touched by the sad voice, and also, let me say, by the blaze of light which had just disappeared from before her eyes, so she said, meekly: "All right, I will drive to my banker, and in an hour I shall be back with the money, madame." This is how she possessed the most marvelous jewels which ever adorned a

when placed rather backward in the middle of her fluffy curls negligently brought up under it.—*Modern Society*.

### Diamonds for Favors.

TO the great diamond loving and dinner giving public the announcement that diamonds are to be used as dinner favors will come as a welcome suggestion. Flowers have long since been discarded as dinner gifts, as constituting quite too modest a display, and many of the trinkets adopted in their stead have likewise failed to find permanent favor. For ostentation, however, pure and simple, nothing could well exceed the extraordinary custom of presenting each dinner guest with a large uncut diamond.

A South African millionaire is responsible, it is said, for starting this fashion in London. Having conceived the idea of celebrating his return to his friends by inviting them all to an elaborate banquet, his generous millionaire soul overflowed naturally in the direction of diamond dinner favors. At dessert, therefore, large uncut gems, the very choicest product of the South African mines, were promptly presented to the guests. Wealthy Londoners have been trying ever since to eclipse this display, but it doubtless remains for some American to bring the diamond rage to a really appropriate climax.—*New York World*.

### Precious Stone Mining Company Organized in Montana.

BUTTE, Mon., May 10.—Articles of incorporation of the Silver Bow, Gold and Precious Stone Mining Company have been filed. The directors are George Miller, F. Y. Wilson, E. S. Booth, W. W. Warren, H. O. Weller and John E. Lloyd. George E. Miller subscribed to 49,994 shares of stock at \$1 per share, and the other six directors took one share each.

Isadore Sands was married recently to Miss Eva Polsky, of Akron.

Marvin H. Richmond will remove from Williamson, N. Y., to Newark, N. Y.

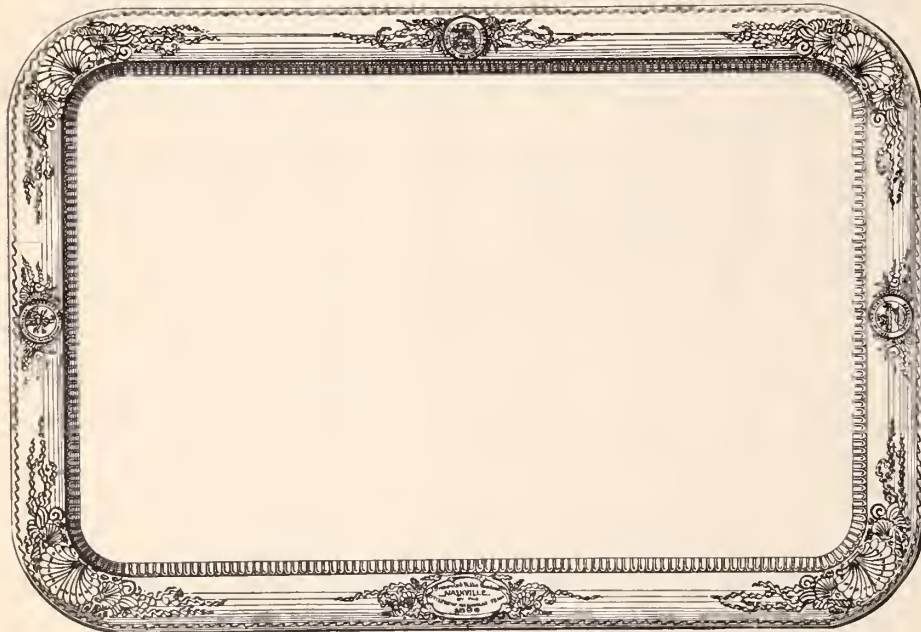

WAITER OF THE SERVICE TO "CITY OF NASHVILLE."—See Page 1.

ceived from her jeweler a telegram asking her to come at once to his shop; there she found a tall woman, thickly veiled, who held in her hands a case with two superb diamonds in it. Big drops, almost as large as the diamonds, were fast falling from her eyes. "Mademoiselle," she said, "Mr. F. tells me that your fancy is to possess a pair of exceptionally beautiful earrings. Those are all that you can desire. Could you pay down for them before

first night in Paris. She likes to tell the story of her bushel of onions, but to this day she never knew who was the woman.

Sarah Bernhardt does not care for diamonds; she prefers the queer and multi-color jewelry of the middle ages; she wears belts, chatelaines and shoulder knots, but very seldom earrings, brooches, bracelets or tiaras. Her last order in the Rue de la Paix has been a tall silver comb, at the top of which leaves



# TWO NEW PIECES FOR

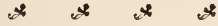

Where would we be if in a quiet season we decided to make **nothing new** till we saw a **demand**?

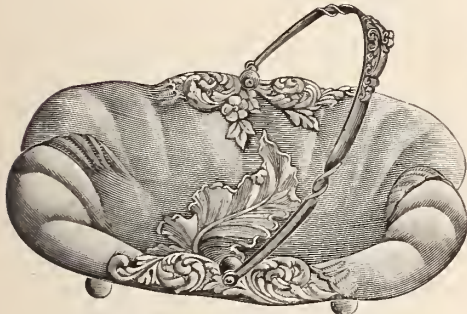

No. 6607. BON-BON DISH.



No. 2846. HAND MIRROR.

# EVERY DAY IN THE YEAR.

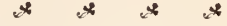

Make the **demand**. Sort up your stock with 25, 50 or 100 new pieces that will make people buy. We furnish goods that sell.

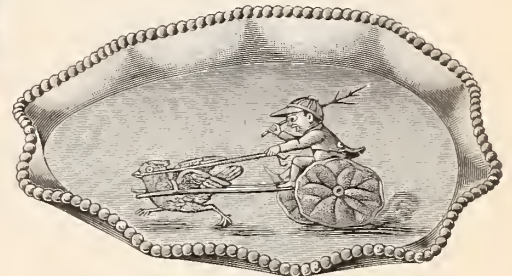

No. 1969. TRINKET TRAY.

FACTORIES,  
NEW BEDFORD MASS.

SALESROOMS,  
NEW YORK. CHICAGO.  
SAN FRANCISCO. MONTREAL.

## PAIRPOINT MFG. COMPANY.

# CARBORUNDUM

THE GREATEST ABRASIVE YET DISCOVERED.

Four times the Labor and Expense-saving qualities of Emery, Corundum or other abrasives. Adapted for Lapidary Work, Grinding, Polishing and every operation where a perfect abrasive is necessary.

### Price List of Carborundum Wheels.

ACHESON'S PATENT, February 28th, 1893; February 26th, 1895.

DIAM. IN.	THICKNESS IN INCHES.																MAX. REV.
	¼	⅜	½	⅝	¾	1	1¼	1½	1¾	2	2¼	2½	2¾	3	3½	4	
1	\$.15	\$.15	\$.20	\$.20	\$.20	\$.25	\$.30	\$.30	\$.35	\$.40	\$.40	\$.45	\$.50	\$.50	\$.60	\$.70	18000
1½	.20	.25	.25	.25	.30	.30	.35	.40	.45	.50	.55	.60	.65	.70	.75	.75	14000
2	.20	.30	.30	.30	.35	.40	.45	.50	.55	.60	.65	.70	.75	.85	.90	.90	11000
2½	.25	.35	.40	.45	.50	.55	.65	.70	.80	.90	1.00	1.10	1.20	1.25	1.40	1.50	8800
3	.30	.45	.55	.60	.65	.75	.85	1.00	1.15	1.25	1.40	1.50	1.60	1.75	2.00	2.20	7400
3½	.40	.60	.65	.70	.80	1.00	1.15	1.30	1.45	1.65	1.80	1.95	2.10	2.20	2.55	2.90	6300
4	.50	.80	.75	.85	1.00	1.20	1.40	1.60	1.80	2.00	2.20	2.40	2.60	2.80	3.20	3.60	5500
5	.70	.85	.95	1.15	1.25	1.60	1.95	2.30	2.60	3.00	3.30	3.65	3.95	4.25	4.90	5.55	4400
6	.95	1.10	1.30	1.55	1.75	2.20	2.70	3.15	3.60	4.10	4.55	5.00	5.45	5.90	6.80	7.70	3700
7	1.25	1.45	1.65	1.95	2.30	2.95	3.50	4.15	4.80	5.40	6.00	6.60	7.20	7.80	9.00	10.25	3160
8	1.50	1.70	2.00	2.40	2.80	3.60	4.40	5.20	6.00	6.75	7.55	8.30	9.10	9.90	11.45	13.00	2770
9	1.80	2.10	2.40	2.90	3.35	4.30	5.30	6.25	7.25	8.20	9.15	10.10	11.10	12.05	14.00	15.90	2460
10	2.15	2.50	2.85	3.45	4.00	5.15	6.30	7.45	8.60	9.75	10.90	12.00	13.20	14.35	16.60	18.90	2210
12	2.65	3.10	3.70	4.50	5.25	6.80	8.40	9.95	11.50	13.05	14.60	16.20	17.75	19.30	22.45	25.50	1850
14			5.05	6.05	7.00	9.00	11.00	13.00	15.00	16.95	18.95	20.95	22.95	24.90	28.90	32.80	1580
16					9.10	11.70	14.30	16.85	19.95	22.00	24.55	27.15	29.70	32.30	37.40	42.50	1380
18						11.25	14.45	17.70	21.00	24.25	27.50	30.75	34.00	37.25	40.50	47.00	1230
20							17.50	21.55	25.55	29.60	33.70	37.80	41.90	45.95	50.00	58.00	1100

The wheels are made with a vitrified bond and pressed under hydraulic pressure. Those over three inches in diameter are turned up after firing. The same numbers are used to designate the degrees of fineness, as are used with Emery, and the wheels are made in seven degrees of hardness, marked SSS, SS, S, M, H, HH, from extremely soft to extremely hard. In ordering, state diameter, thickness, hole, number and hardness.

Hones, Slabs, Files.

CUT THIS OUT.

## THE CARBORUNDUM CO.

WORKS: MONONGAHELA, PA., AND NIAGARA FALLS, N. Y.

### The Organization of the Watrous Mfg. Co.

HARTFORD, Conn., May 7.—The Watrous Mfg. Co., of Wallingford, who have organized, as already announced in THE CIRCULAR, have filed a certificate of organization with the Secretary of State. The capital stock is \$125,000, divided into 5,000 shares of \$25 each. The stockholders with the number of shares are as follows: Franklin Farrell, Ansonia, 680; D. J. Maltby, Waterbury, 920; Maltby, Stevens & Curtiss Co., 1,000; W. H. H. Wooster, trustee, Seymour, 500; B. D. F. Curtiss, Rye, N. Y., 400; W. H. Watrous, Hartford, 300; G. D. Munson, Wallingford, 200; W. H. Watrous, trustee, Hartford, 998; S. J. Bryant, New Haven, 1; W. N. Clark, Jr., Ansonia, 1; total 5,000.

Treasurer George D. Munson is also made manager. W. H. Watrous, besides being president of the new company, is president of the William Rogers Mfg. Co., Hartford, and president of the Norwich Cutlery Co., of Norwich. The new manager, George D. Munson, has been traveling salesman for the William Rogers Mfg. Co. for ten years past. He is an active worker, and his experiences in the markets for silver goods about the country will prove valuable to him in the position he is to fill in the new company.

The Maltby, Stevens & Curtiss Co. were organized some 16 years ago in Birmingham and began the manufacture of spoons and forks for the Rogers Company, of Hartford. About 13 years ago the company were burned out in Birmingham, and moved into the factory now occupied by Hall & Elton Co., Wallingford. Five years ago they leased the property owned by the Oneida Community for two years, and at the end of that time the property with the water privilege was purchased by the com-

pany. All the spoons and forks manufactured by the Maltby, Stevens & Curtiss Co. were taken by the Rogers Company. Since moving into the Community property the Maltby, Stevens & Curtiss Co. have been engaged in making German silver hollow ware and sterling silver specialties besides spoons and forks. The new company will continue in the same line of goods. The works again started up Wednesday after a 6 days' shut-down for inventory.

### Receiver Appointed for the Business of De Raismes & Co.

NEWARK, N. J., May 6.—Vice-Chancellor Reed yesterday appointed Elwood C. Harris receiver for the jewelry firm of De Raismes & Co., of which Arthur E. Lebkuecher, a brother of the Mayor, was a member. The firm did business at 295-297 Washington St., and the action of the Vice-Chancellor is the result of an application made by Mr. Lebkuecher on April 29th last before Vice-Chancellor Emery.

Besides asking for the appointment of a receiver the bill filed prayed for a dissolution of the partnership. The firm was formed on Jan. 1st, 1893, and was made up of Mrs. Emma C. De Raismes and the applicant for the appointment of a receiver. This step was agreed upon by the partners interested, and certain of the assets have been already sold. A new company have formed, known as De Raismes & Co., who are in business at 23 Marshall St.

### Proposals for Clocks for the Treasury Department.

WASHINGTON, D. C., May 8.—The Treasury Department is inviting sealed proposals until June 1st, for supplying 8-day, pendulum wall clocks, with 12-inch dials, of standard make, and electric or synchronizing systems of clocks, for United States public buildings under the

control of the Treasury Department, east of the Rocky Mountains, during the fiscal year ending June 30, 1897; frames of clocks to be oak, cherry or walnut. The bids for electric clocks must include all expenses for installation. The prices stated must include all expenses incident to delivery to such buildings as the department may, from time to time, designate.

Further information regarding this contract may be obtained upon application to S. Wike, Acting Secretary, Washington, D. C.

A magnificent turret clock has recently been manufactured for Philadelphia, Pa., by W. F. Evans & Sons, Soho Clock Factory, Handsworth, Birmingham, England. The bed is of cast iron six feet long, and all wheels and bushes are of gun metal. The main wheels are 16 inches in diameter and 1½ inches thick. The pinions are cut out of solid cast steel, the escapement is Dennison's double three legged gravity compensation, pendulum of iron, and zinc tubes and steel rod, carrying a ball weighing two cwt. The quarter's cam barrel is made on a new and improved principle, consisting of iron rings into which the cams fit for lifting the hammers, and can be adjusted in any way required. There are many recent improvements in the construction of this clock, all cams and levers being of cast steel, hardened and tempered. Any wheel or pinion can be taken out of the clock separately, the bushes being screwed in at both ends. There are over 900 pieces in the clock and dial work. The clock chimes all the quarters, strikes hours on a ton bell, and shows time on four large dials. A similar clock has recently been made by the same firm for St. Timothy's, near Baltimore, Md.



SALAD BOWL AND SERVERS.

## DORFLINGER'S AMERICAN CUT GLASS

— FOR —

### JUNE WEDDINGS.

SUPPLY SHOULD  
BE ORDERED NOW.

## C. Dorflinger & Sons,

36 MURRAY STREET, 915 BROADWAY,  
NEW YORK.

COMBINATION  
PURSE AND  
GLOVE  
HOOK.

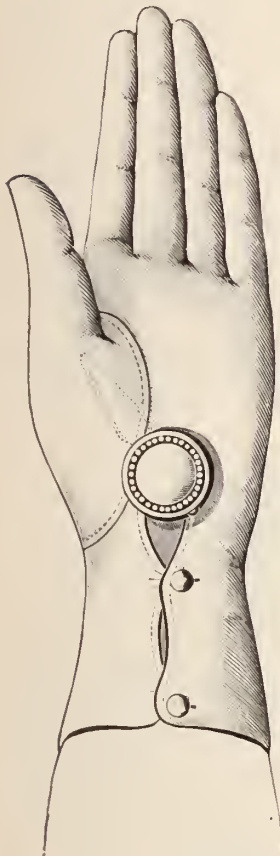

This absolute-ly new article is bound to have a large sale. It is extremely convenient, serves as an easily accessible carrier for small change such as is required for carfare—is securely held in the palm of the hand and saves its wearer from the insanitary practice of holding coin between the lips.

A SPLENDID NOVELTY  
MADE IN STERLING SILVER.



We are makers  
of Sterling  
Silverware  
Exclusively.  
All goods  
925-1000 fine.

F. M. WHITING CO.,  
North Attleboro,  
Mass.

Don't Sell a Trunk Strap

for a leather belt! Did you ever watch a woman put on or take off a trunk strap, either on a trunk or on herself? Did you ever see the strap thereafter? Then let her try our "ECCENTRIC" belt and see her delight at finding a belt that LOCKS ITSELF just as tight as she desires and opens in a second.

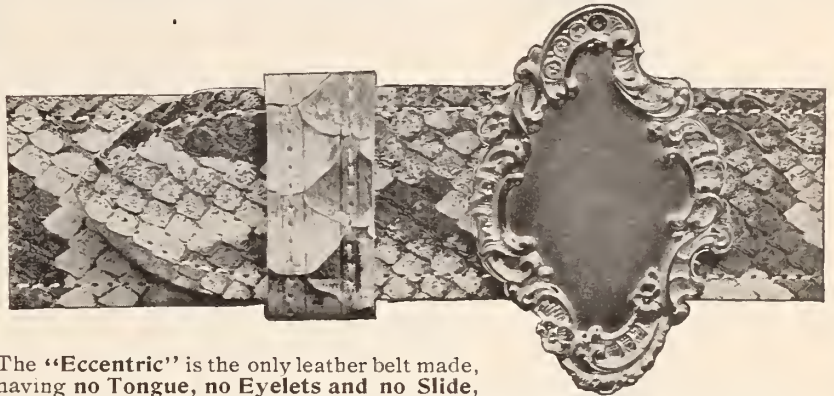

The "Eccentric" is the only leather belt made, having no Tongue, no Eyelets and no Slide, that ADJUSTS ITSELF and has solid front sterling buckles, which being independent of the belt will enable you to sell several different colored leathers, to match the wearer's dresses, with each buckle.

Have you seen our Belt Hook, by using which our belt can be worn with a shirt waist?

Sold to Jewelers only.

Samples on Application.

THE FINEST BICYCLE BELT IN THE WORLD.

SPIER & FORSHEIM,



PATENTEES,  
NEW YORK.

31 1/2 Maiden Lane,

New Roy 12 Size  
Waltham Cases.  
Now on the Market.

SYMMETRY, STRENGTH, BEAUTY OF FINISH, SWISS HEAD SPRINGS, GOLD DUST BANDS, EXTRA THIN.

These are points of excellence which, as a result of years of experience, we have been able to make the most of, in constructing these splendid cases. They are made for the finer class of trade, only. Leading jobbers handle Roy Solid Gold Cases. Look for this Trade-Mark in every case.



18K. **ROY** 14K.  
TRADE MARK REGISTERED.

ROY WATCH CASE CO., 21 Maiden Lane, N. Y.

**FASHION'S DECREE** Is that **LEATHER BELTS** and **SHIRT WAIST SETS** will be the proper thing for 1896. If you wish to be in it, send for samples and circulars.

**A NOVELTY FOR BICYCLISTS.**

BELT AND POCKET BOOK COMBINED, WITH PLACE IN BACK TO HOLD HANDKERCHIEF.

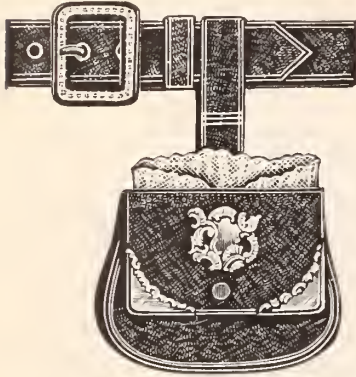

159. SEAL (1 inch belt), Complete...\$1.50  
Made also in Genuine Morocco and Calf, at from \$1.62 to \$2.12 each.

ALL GOODS GENUINE LEATHER, MOUNTED IN STERLING SILVER, GUARAN' EED 925-1000 FINE



167, MOROCCO; 171, CALF, all assorted colors; 173, WHITE KID; all 1 inch widths.....\$12.00 Doz.

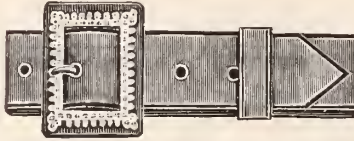

165, SEAL; 163, MOROCCO; 170, CALF, all assorted colors; 181, WHITE KID; all 1 1/2 inch widths.....\$15.00 Doz

*THE DIFFICULTY AT LAST OVER-COME.—Our Patent Belt Pin, when attached to the leather belt, makes it impos- sible for the skirt to slip or become disarranged.*

**STERLING SILVER WAIST SETS — GUARANTEED .925 FINE.**

**\$3.50 PER DOZ. 12 DIFFERENT STYLES AT THIS PRICE.**

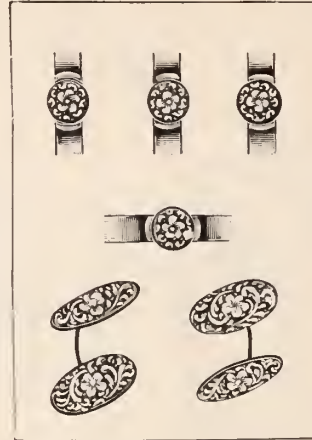

Cut 1/2 actual size.

This is undoubtedly the best article in the market for the money. Every button has an extra piece of silver soldered on the rim, so as to add to its style finish and durability, and is not a mere shell like most of the low priced waist sets on the market. We also have these goods in extra heavy, bright cut, chased patterns, at \$4.50 per dozen, and in silver, enameled, with or without Roman finish from \$7.50 to \$15.00 per dozen.

**S. C. POWELL, STERLING SILVER NOVELTIES, 51-53 Maiden Lane, New York.**

**A** **AMERICAN** **WATCH TOOL CO.**

ESTABLISHED 1872. INCORPORATED 1894.

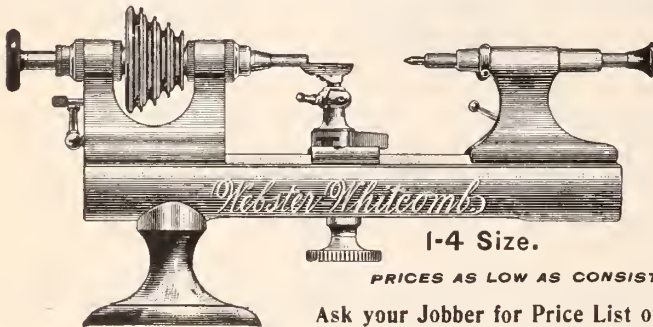

THE **Webster=Whitcomb**

GROWS IN POPULARITY

PRICES AS LOW AS CONSISTENT WITH QUALITY.

Ask your Jobber for Price List of 1895, or write to us at

**Stoney - Batter Works, Chymistry Dist., Waltham, Mass.**

**NYE'S SUPERFINE OILS.**

Special grades for

CHRONOMETERS, WATCHES, CLOCKS, JEWELERS' LATHES, ETC., ETC.



NYE'S OILS acknowledged SUPERIOR TO ALL OTHERS.

**WM. F. NYE,** Manufacturer, New Bedford, Mass.

**“Apparel oft proclaims the man.”**



HOLYOKE, MASS., U. S. A.

**CHOICE PAPERS**

So with our fine note papers, envelopes and papeteries—all our bands, boxes and labels are neat, tasty and artistic and perfectly in keeping with and a credit to the high grade goods with which they are used. Our fashionable stationery is put up in a manner that appeals to people of refined tastes, and it is a line particularly adapted for jewelers. We **do not** sell to dry goods or department stores. Write for samples.

**PARSONS & GREENE Co.,**  
MANUFACTURING STATIONERS,  
HOLYOKE, MASS.

**Disappearance of Three Members of the Trade in Springfield, Mass.**

SPRINGFIELD, Mass., May 8. — Springfield jewelry circles have been unusually agitated during the past week or so by the disappearance of two prominent members, each of whom went away under a cloud. C. E. Landis was the first to disappear. He left a number of small bills besides taking a number of articles belonging to customers and friends, although his actual indebtedness cannot be stated. On April 29th he had his goods shipped to St. Louis, but it is believed that they were ultimately intended to go to Butte, Mont.

Landis came to this city a few years ago after a somewhat checkered career in other cities, and apparently built up quite a nice business. He was recognized as one of the best diamond setters in the city. He was one of the organizers of the Massasoit Bicycle Club, but was compelled to withdraw on account of objectionable actions. A peculiar circumstance in connection with his disappearance is that his clerk, a man by the name of Farley, suddenly left town a week before him. Farley was employed by Horne, the jeweler who disappeared from Nashua, N. H.,

a year or so ago. Horne, it will be remembered, formerly worked for L. S. Stowe & Co., this city. Following right on the heels of the disappearance of Landis, came that of H. W. Spellman, optician, who seemed to have more method in his madness than his predecessor. Spellman was located in J. C. Manning's jewelry store, and worked as usual on Saturday, May 2d. On the following day he met one of the clerks of the store and borrowed the key in order to get his umbrella, as he claimed. He did not report for duty Monday, and when Mr. Manning returned Monday night he found that a gold watch and a number of gold eyeglass frames were missing, while he later discovered that Spellman had spent Monday morning collecting small accounts due the firm, which netted him about \$40. Mr. Manning is of the opinion that more of the stock is missing, but cannot tell definitely until he has taken an inventory. Spellman was formerly in the jewelry business in Nashua, N. H., but made a failure of it, and since then has been posing as an eye specialist in Boston, Lowell and this city.

Alex I. Wyatt, Salt Lake City, Utah, has removed to a larger store at 172 Main St.

**Litigation Over the Use of the Name of Gundlach in the Optical Business.**

ROCHESTER, N. Y., May 9. — Ernest Gundlach, the optician and inventor, has just begun an action against the Gundlach Optical Co., demanding that the company be restrained from the further use of his name. Mr. Gundlach has achieved a high reputation, both in this country and in Europe, as an expert in the science of optics and inventor of various optical instruments. For seven years he was a manufacturer of optical goods in Berlin, Germany, doing business under the style of E. Gundlach. In 1871 he came to this country and went into the business of manufacturing optical goods at Hackensack, N. J. Five years later Bausch & Lomb, of this city, induced him to take charge of their exhibit at the Centennial exhibition. He remained with Bausch & Lomb for over two years, during which time he did not manufacture in his own name; but his inventions, which were used by the firm, were stamped "E. Gundlach."

After severing his connection with Bausch & Lomb, Mr. Gundlach commenced to do business on his own responsibility, having his place of business on St. Paul St., eventually going into partnership with three men, named John

**COMBINATION BELT AND SKIRT SUPPORTER.**

(PATENT APPLIED FOR.)

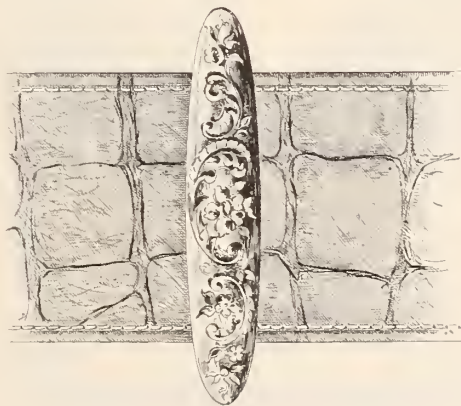

UTILITY,  
SECURITY,  
SIMPLICITY.

**DEITSCH BROS.,**  
— MAKERS, —



1 Inch, \$12.00 Doz.

1 1/4 Inch, \$13.50 Doz.

1 1/2 Inch, \$15.00 Doz.

**7 East 17th St.,**  
NEW YORK.

IT IS .... A  
**DEAD SURE THING**



...THAT...  
"WAITE, THRESHER'S GOODS SELL."

WAITE, THRESHER COMPANY,  
MANUFACTURING JEWELERS,  
PROVIDENCE, R. I. N. Y. OFFICE, 178 BROADWAY.

We carry the largest,  
finest and most complete  
line of Mounted Diamond  
Jewelry of any house in  
America.



Zellweger, John C. Reich and Henry H Turner. An agreement was drawn up, whereby these three were to put in \$600 apiece, while Gundlach was to furnish as his contribution to the partnership, his instruments and machinery. This was the commencement of the present corporation known as the Gundlach Optical Co.

Under this agreement the partnership continued for nine years, Mr. Gundlach having charge of the theoretical, experimental and scientific part of the business. Becoming dissatisfied with his share of the profits, he expressed a desire to retire from partnership. New articles were then drawn up, whereby the old partnership was dissolved and a new one formed under the same name. By this Gundlach assigned to the partnership all his patents, and was to receive as his share of the net profits 12 1-2 per cent., the royalty to be paid in weekly payments of not less than \$30. Under this agreement Gundlach did not have to devote his whole attention to the business, but was to give the company, at any time they wished, the benefit of his technical knowledge.

In June, 1892, Gundlach began action against the optical company, claiming that they had got behind in their payments to him, and demanding an accounting. The other partners at the same time commenced a counter-action against the inventor, claiming he had violated his agreement with them. These suits were finally settled and never brought to trial.

Two years later Mr. Gundlach and the other partners had another disagreement, which resulted in his withdrawing from the partnership and receiving a re-assignment of the patents included in the articles of agreement, but the company continued to do business under the style of Gundlach Optical Co. and were incorporated under this name a few months later.

Mr. Gundlach, it appears from the moving papers, has since started in the optical business for himself once more and has a new photographic camera which he thinks will revolutionize things and which he is desirous of placing on the market. In fact he has formed a company known as the Gundlach Photo-Optical Co., but finds himself handicapped by the presence in the field of another Gundlach Optical Co. The courts are asked to enjoin the defendants from the further use of the plaintiff's name both in the manufacture and sale of their optical goods or as a part of their corporate name.

**This Jeweler Works Upon the Credulity of Women.**

DECATUR, Ill., May 10.—L. R. Wood, who was in the jewelry business on N. Water St., this city, last Summer, and got into trouble last August for selling goods that had been sent him by a Chicago firm on memorandum, has been showing his dishonesty again. This time it is at Clinton, Mo., to which place Wood went several months ago. A letter has been received in Decatur from Mrs. M. L. Crandall, of Clinton, asking about Wood. She writes that he induced her to mortgage her home for \$600 and start him in the jewelry

business, it being the agreement that she should have half the profits of the business and that he would, as soon as he made the money from his share, pay her back the \$600. Wood was also to teach her son the trade of a jeweler. Wood represented to her that he was the son of a well-to-do man in Decatur, and that he would, some time in the near future, fall heir to considerable property.

Last week, so Mrs. Crandall writes, Wood secretly disposed of most of the stock in the jewelry store and skipped the town, and she is now trying to get trace of him and wrote to this city to learn what she could about him.

**Proceedings of the Philadelphia Horological Society.**

PHILADELPHIA, Pa., May 9.—The regular monthly meeting of the Philadelphia Horological Society was held at its rooms, Broad St. and Columbia Ave., on the evening of May 7, President Lewis presiding. There was a large attendance of members and visitors, and it was exceedingly gratifying to note the increased action taken in the work of the Society by the greater attendance of members and others interested in horology.

After the transaction of the usual routine business the lecture of the evening, as previously announced, was given by President Lewis, on "Friction, Lubrication and the Lubricants in Horology." The lecture treated on the various oils and lubricants employed for horological purposes, their sources of origin and manner of treatment; some elementary physical laws relating to oiling and friction, explaining the different kinds of friction and the proper method of reducing it.

The whole subject of the various lubricants, and the best manner of making an efficient bearing for pivots and the retention of oil therein, is one to which insufficient attention has been given; in fact it seems to have been a neglected field of inquiry in horology.

As the hour was growing late and it being impossible for President Lewis to finish his lecture in one evening, it was agreed that the concluding part be read at the June meeting, when the usual discussion will take place as is customary with all papers read before the Society. After a vote of thanks to the lecturer for his able address the meeting adjourned.

The "Perfection" leather belt holder is a new and valuable device recently put on the market by Spier & Forsheim, 31½ Maiden Lane, New York. With this article it is possible for a lady to wear a shirt waist and skirt, with the popular narrow belt, without the skirt band showing below the belt. Stamped from one piece of sterling silver, it is firm and strong, and has no joints, pins nor hooks to break or tear the skirt. The "Perfection" hook is rightly named. It is small, neat, strong and convenient. These hooks are sold to purchasers of Spier & Forsheim's well known Eccentric belts at cost, \$2 per dozen.

**NO TRAP**

TO BREAK OR CURL, YET

**TRONG,**

**TYLISH**

AND

**LOW IN PRICE THAT EVERY UP-TO-DATE OPTICIAN SHOULD BUY THEM.**



**H. E. KIRSTEIN & CO.,**

**ROCHESTER, N. Y.**

**KETCHAM & McDOUGALL,**

MANUFACTURERS OF

**GOLD AND SILVER THIMBLES**

ESTABLISHED 1832.



No. 149.



TRADE-MARK.



Pat'd Nov. 20, '94.

And the improved

**Automatic Eye-Glass Reel.**

**198 BROADWAY, NEW YORK.**

SEND FOR CATALOGUE C.

**Fine Leather Belts,** **LARGE ASSORTMENT.**



We are equipped to make, at short notice, any style of belt to fit buckles which Jewelers may furnish. We carry in stock a large variety with leather covered Sterling Silver and Gold Plated Buckles.

SEND FOR DESCRIPTIVE PRICE LIST.

**C. F. RUMPP & SONS,** MANUFACTURERS OF

**Fine Leather Goods,** Fifth and Cherry Streets, Philadelphia.

New York Salesroom, 402 Cable Building, 621 Broadway

**DIAMONDS.**  
**Wm. S. Hedges & Co.,**  
 IMPORTERS OF  
 Diamonds and Precious Stones.  
 DIAMOND JEWELRY.  
 170 Broadway, New York.  
 22 Holborn Viaduct, London.

**Alfred H. Smith & Co.,**

IMPORTERS

DIAMONDS

AND

PRECIOUS STONES,

182 BROADWAY, COR. JOHN STREET,  
 NEW YORK.

Venetian Building, 34 & 36 Washington St  
 CHICAGO, ILL.

**Purchasers**

.. OF ..

**RARE GEMS,**

PRECIOUS STONES  
 AND ALL GOODS FOR  
 JEWELRY,

ADDRESS

**R. A. KIPLING, Paris,**  
 19 Rue Drouot, France.



L. BONET,  
 ESTABLISHED 1866.

**CAMEO  
 PORTRAITS**

Works of Art,  
 Precious Stones.

927 BROADWAY  
 NEW YORK.

DON'T FORGET THE JEWELERS' CIRCULAR PUBLISHING CO.'S BOOK LIST when in want of any technical book in the Jewelry or Kindred Trades.

**SCHULZ & RUDOLPH,**  
 IMPORTERS AND CUTTERS OF  
**DIAMONDS AND OTHER PRECIOUS STONES,**

(Successors to JOHN E. HYDE'S SONS.)

Sole Agents for The Celebrated Jules Jurgensen Watches.

28 JOHN ST. and 65 NASSAU ST., NEW YORK.

**The Bowden Rings**

ARE COMPLETE IN VARIETY, CORRECT  
 IN QUALITY AND PERFECT IN FINISH.  
 WE MAKE EVERY VARIETY OF FINGER  
 RINGS

**J. B. BOWDEN & Co.,**  
 3 MAIDEN LANE,

BRANCH OFFICE :  
 206 KEARNY STREET  
 SAN FRANCISCO, CAL.

NEW YORK.

**Early Summer Fashions in Jew-  
 elry and Silver.**

A LADY'S RAMBLES AMONG THE JEWELERS.

An addition to the writing desk which fills a long-felt want, is a silver pen extractor.

\*

Women everywhere, at home and abroad, are wearing long gold chains. To these chains are attached a watch, lorgnette, locket or other convenient article.

\*

Open-work silver is a feature of the season, and greets one in many forms.

\*

Silver ice tongs and three pronged berry forks are now in demand.

\*

Card cases and pocketbooks of elephant's hide are mounted at the corners in dull gold.

\*

Chatekaine bags of monkey skin, with rose gilding clasps, have numerous adherents.

\*

The belt buckles and clasps enameled in dull reds, blues and greens defy description.

\*

Very reasonable are the cut glass pitchers with silver mountings for "claret cups." Accompanying these pitchers are spoons with abnormally long handles for stirring the beverage.

\*

English women who, by the by, are wearing a profusion of jewelry, have a decided predilection for massive gold bracelets.

\*

Some of the new claret jugs have silver lids lip-shape.

\*

Letter receivers in tortoise shell with applied gold decorations, have two compartments, one for answered and one for unanswered missives.

\*

The darning is one of many prosaic articles which have become luxurious at the silversmith's hands. The up-to-date darning consists of a fine china egg with a long silver handle.

\*

Card cases set with turquoises are neat and pretty.

\*

Oblong bread trays in silver plate closely copy the old-time wooden affairs in size and form.

\*

Silver fruit dishes with solid body, open work top, and standing on ornately carved feet, are very decorative in effect.

\*

Well dressed women are wearing more jewelry than before in many years.

ELSIE BEE.



**Annual Meeting of the Jewelers' Security Alliance.**

The 13th annual meeting of the Jewelers' Security Alliance was held at the office of the organization, 170 Broadway, New York, Tuesday, May 5th, at 3 o'clock P. M. The meeting was called to order, in the absence of the president, by first vice-president Henry Hayes. The minutes of the last annual meeting were read, and on motion, approved.

The treasurer's yearly report was read, and on motion, accepted and ordered placed on file. The report of the auditing committee was also read, and on motion, accepted and ordered placed on file with the treasurer's report, with the thanks of the Alliance to the treasurer and committee for their services. The report of the executive committee after being read, was on motion accepted and ordered placed on file.

REPORT OF THE EXECUTIVE COMMITTEE.

Mr. President and Members of The Jewelers' Sec. Alliance.

Your Executive Committee submit their thirteenth annual report.

We have held eleven regular (and one special) meeting, at which has been transacted the business necessary for the protection of the Alliance and its members. Since the last annual meeting we have admitted to membership 157 and reinstated 2; 82 have been dropped or withdrawn making our present membership 1,545, a gain of 77. You will note that the Alliance increases its membership every year, and but for the hard times we believe the increase would be much more rapid.

We advised you in our last report that A. Bourgeois, Jackson, Miss., had been robbed, and that we had captured one of the burglars, and were after the other, there being two in the job. He gave us a long and expensive chase, but we got him after almost a year, and he was sentenced at Jackson for five years. The other man whom we first captured has since died in jail. We were also able to return to Mr. Bourgeois some of his goods.

The very healthy respect a capture like this creates for the Alliance is marked, and generally for a year or more thereafter no member is molested. Not a member has been robbed since.

An attempt to rob the safe of Wm. F. Kercher & Son, Philadelphia, Pa., was made last September, the thieves destroying the safe door and locks, but were evidently frightened away as they did not gain access to the contents of the safe, and the only loss resulting was the damage to the safe and combination.

The Alliance is no longer an experiment, but has demonstrated its usefulness, and the necessity for such an organization, and with ample means to meet all demands is worth more to every member, and holds out more reasons to-day why every jeweler who has a valuable stock should become a member than ever before.

We wish to thank the trade journals on behalf of our members for liberal notices during the year.

The election of officers being next in order, nominations for president were called for. J. B. Bowden was nominated, and being the only nominee, the secretary was instructed to cast one ballot for him as president of the Alliance for the ensuing year, and he was declared elected. Nominations for vice-presidents being next in order, Henry Hayes, David Untermeyer and N. H. White were nominated for first, second and third vice-president respectively. On motion, the secre-

ESTABLISHED 1840.

LANDEL, BAREMORE & BILLINGS,

IMPORTERS OF

DIAMONDS,

AND OTHER PRECIOUS STONES.

FINE PEARLS A SPECIALTY.

MANUFACTURERS OF

DIAMOND JEWELRY

A Large Stock of Fine Mounted Goods Constantly on Hand.  
Goods Sent on Approval and Insured in Transit.

Diamonds Cut, Recut and Repaired.

58 Nassau Street,  
29 Maiden Lane.  
NEW YORK.

1 Tulp Straat,  
AMSTERDAM.

1 St. Andrew's St.,  
Holborn Circus.  
LONDON E. C.

ESTABLISHED 1841.



CARTER, HASTINGS & HOWE,

MANUFACTURERS OF

GOLD JEWELRY,

15 MAIDEN LANE, NEW YORK.

A. CARTER,

C. E. HASTINGS,  
W. T. CARTER

G. R. HOWE,  
W. T. COUCH

FACTORY, NEWARK, N. J.

JOHN P. CAMPBELL,

MANUFACTURER OF

WATCH CASES.

ALL KINDS OF SPECIAL CASE WORK.  
REPAIRING A SPECIALTY.

59 Nassau St., Cor. Maiden Lane, New York.

Royal Arcanum and Maltigue Ladies' Enamel Cases.

HERMAN KOHLBUSCH, SR.

Established 1859  
Manufacturer of  
FINE BALANCES  
AND WEIGHTS for  
every purpose  
where accuracy is  
required. 59 Nassau  
Street, cor.  
Malden Ls. N. Y.

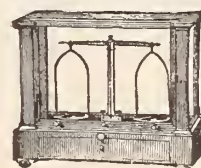

Repairs (any make)  
promptly made.

# OPPENHEIMER BROS. & VEITH,

CUTTERS OF DIAMONDS,

DEALERS IN WATCHES,

65 NASSAU STREET (PRESCOTT BUILDING), NEW YORK

A. WALLACH & CO.,  
Manufacturers of

**Gold Chains,**

11 Maiden Lane,  
NEW YORK.

Adolph Wallach, {  
Antony Wallach, {

**This card**  
appeared in the "Jewelers' Circular" of April 15, 1870.

**For 50 years**  
Wallach Fine Gold Chains have been recognized as the standard.

**We have**  
recently removed to new quarters at

**37 and 39 Maiden Lane,  
Lorsch Building,  
Room 8.**

A. WALLACH & CO.

L. ROSENBERGER,  
M. ROSENBERGER.



## A 1 MUSLIN BUFFS.

Sample sent prepaid on request.  
BE SURE to give size of buff and center hole.

**WILLIAMSVILLE MFG. CO.,**  
18 South Water St., PROVIDENCE, R. I.  
MILLS: WILLIAMSVILLE, KILLINGLY, CONN.

## PATEK, PHILIPPE & CO., GENEVA, SWITZERLAND.

MAKERS IN THE HIGHEST QUALITY OF

Fine, Plain, Complicated  
And Decorated Watches

IN 15 DIFFERENT SIZES.

INTERCHANGEABLE PARTS.

NEW YORK OFFICE, 68 NASSAU ST.

ALFRED G. STEIN, Representative.

### PHILIP BISSINGER & CO.,

IMPORTERS OF

PRECIOUS STONES, PEARLS, CORALS and GARNETS,

ANNOUNCE THEIR

**REMOVAL**

FROM

22 TO

20 JOHN ST., N. Y.

tary was instructed to cast one ballot for each of these gentlemen, which was done and they were declared unanimously elected for the ensuing year. Bernard Karsch was nominated for the position of treasurer. There being no other nominations, on motion the secretary was instructed to cast one ballot for him, which was done, and Mr. Karsch was declared elected. There being three members of the executive committee to be elected, nominations were called for, resulting in names of F. Kroeber, Henry Abbott and Chas. F. Wood. On motion the secretary was instructed to cast one ballot for these gentlemen, and they were declared elected for a term of two years.

It was moved and carried that a vote of thanks be extended to the trade journals for the interest they have shown in the Alliance and courtesy displayed in publishing the notices during the past year.

C. C. Champenois and David Keller was appointed as auditing committee for the ensuing year. It was moved and carried that the address of the vice-president and the report of executive committee be printed and sent to the members. The meeting then adjourned.

A special meeting of the executive committee of the Alliance was held at the close of the annual meeting. There were present: Vice-presidents Henry Hayes and N. H. White, B. Karsch, treasurer, and Messrs. Butts, Abbott, Wood and Hodenpyl. The meeting was called to order by vice-president N. H. White.

On motion made and carried, Geo. H. Hodenpyl was nominated for secretary of the Alliance for the ensuing year, and was unanimously elected. H. H. Butts was nominated for chairman of the executive committee for the ensuing year, and was unanimously elected.

The following applications for membership were received and accepted: A. Hank, 26½ E. 42d St., New York; Fred E. Mason, 208 Sutter St., San Francisco, Cal.; Harvey D. Pascal, Fishkill-on-Hudson, N. Y.; Pfaelzer Bros. & Co., 819 and 821 Market St., Philadelphia, Pa.

NEW YORK, May 5, 1896.

*Editor of THE JEWELERS' CIRCULAR:*

At the annual meeting of the Jewelers' Security Alliance held on the above date, a resolution was unanimously adopted expressing the thanks of the members of the Alliance to the several trade journals for their very liberal reports of the proceedings of the meetings of the executive committee and of the work performed by the Alliance in detecting and capturing burglars.

The Officers of the Alliance, who devote their time and attention gratuitously to work for the benefit of the members feel that the present prosperity of the organization is very largely due to the publicity you have so freely given to their work and heartily join with the members in this expression of thanks.

Very truly yours,

H. H. BUTTS, *Chairman,*  
Executive Committee.

## TESTING THE DIAMOND TARIFF SCHEDULE.

Application to the United States Supreme Court for a Writ of Certiorari on behalf of Jos. Frankel's Sons vs. the New York Collector of the Port.

WASHINGTON, D. C., May 8. — Application was made in the United States Supreme Court, Monday last, as reported exclusively in THE CIRCULAR last week, for a writ of certiorari, on behalf of Joseph Frankel's Sons, New York, relative to a decision rendered against them in the United States Circuit Court of Appeals for the Second District.

The case in question, briefly stated, is as follows: Sept. 15th, 1894, the appellants imported, per steamship *Augusta Victoria*, and entered for consumption at the port of New York, certain diamonds, upon which duty was assessed by the collector of the port at 25 per centum ad valorem, under paragraph 338, of the Act of Aug. 28, 1894, which reads as follows: "Precious stones of all kinds, cut but not set, twenty-five per centum ad valorem; if set, and not specially provided for in this Act, including pearls set, thirty per centum ad valorem; imitations of precious stones, not exceeding an inch in dimensions, not set, ten per centum ad valorem, and on uncut precious stones, of all kinds, ten per centum ad valorem."

The appellants protest against this assessment, claiming that the diamonds should have been exempt of duty under paragraph 467, which is in the free list of above named Act, and reads as follows: "Diamonds; miners', glaziers' and engravers' diamonds not set, and diamond dust or bort, and jewels to be used in the manufacture of watches or clocks." The necessary papers in the case were submitted to the Board of General Appraisers, as required by Section 14, of the Customs Administrative Act of June 10, 1890, and that Board, after a public hearing, at which testimony was taken, rendered a decision overruling the action of the Collector and sustaining the claim of the importers. The collector of the port appealed from this decision, and after the removal of the case to the Circuit Court testimony was taken on his behalf. The cause was heard before Judge Townsend, in May, 1895, and a decision was given reversing the decision of the Board of General Appraisers and affirming the action of the Collector. On March 9th an appeal from the decision of the Circuit Court was argued in the Circuit Court of Appeals for the second circuit, and at the conclusion of the argument the Court orally announced that the judgment of the Circuit Court was affirmed on the opinion of that Court.

The opinion of the Circuit Court thus approved and endorsed by the Circuit Court of Appeals lays down certain propositions of law which are diametrically opposed to the rulings of this court, and which, if not corrected, will throw the interpretation and administration of the customs law into confusion.

The following instance is cited by the plaintiffs: The Circuit Court ruled that the phrase "precious stones of all kinds, cut but not set," not only concededly covers diamonds, but is a specific provision and the only provision for "cut" diamonds. The counsel for the Government strenuously contends that the phrase "precious stones, cut but not set," is a more specific description of these diamonds cut but not set in the condition in which they are imported than the single word "diamonds" in the free list. In that event the more specific provision must control. The plaintiffs claim, however, that this is contrary to a long line of decisions in this Court, and quote as examples *Arthur vs. Rheims*, 96 U. S. 143; *Arthur vs. Lahey*, Id., 112; *Worthington vs. Abbott*, 124 U. S. 433; *Robertson vs. Salomon*, 130 U. S., 412; and *Robertson vs. Glendenning*, 132 U. S. 158. In all of these instances the principle is laid down that where an article is provided for by its specific name (*e. g.*, thread laces, artificial flowers, handkerchiefs), generally terms in the same or other acts which would otherwise include them are not applicable to them.

They cite a further instance where the Circuit Court alluded to "the history and admitted object of said statute to increase duties on luxuries and reduce duties on necessities," as a circumstance which influenced its decision. It is submitted that the history of this statute does not bear out this view, neither does an analysis of its provisions, where we find taxes reduced on cigars, leaf tobacco, ale, porter, and beer, oil paintings transferred to the free list, and sugar removed therefrom to be subjected to a duty of 40 per centum ad valorem. They urge still further that the Circuit Court ignored the rule laid down by the Supreme Court, namely: that all doubts as to the liability of an article to taxation are to be resolved in favor of the citizen as was done in the case of the United States *vs. Isham*, 77 Wall, 504; *Hartranft vs. Wiegmann*, 121 U. S., 616; *Ross vs. Barland*, 1 Peters, 657; and the *American Net & Twine Co. vs. Worthington*, 141 U. S., 468.

A better appreciation of the questions presented by this case will be gained by comparing paragraph 467 of the present act which provides for diamonds, with the corresponding provision of the Tariff Act of 1890 as contained in paragraph 557, which was as follows: "Diamonds and other precious stones, rough or uncut, including glaziers' and engravers' diamonds not set, and diamond dust or bort, and jewels to be used in the manufacture of watches."

They contend that Congress provided in paragraph 338 of the present Act for the class of articles known as precious stones, both cut and uncut, and, therefore, the words "and other stones rough or uncut," were eliminated from the diamond paragraph. They also point out the fact that it extended the diamond paragraph to cover miners' diamonds and clock jewels. If the paragraph had been allowed to stand "diamonds, including miners', glaziers' and engravers' diamonds not set, and diamond dust or bort, and jewels to be used in the manufacture of watches or clocks," it would not be denied that all diamonds not set so as to constitute jewelry were free. The courts below have held that the striking out of the word "including" and the substitution for that word of a semicolon had the effect to convert the word "diamonds" into a mere heading, with no force and effect whatever, yet an examination of the tariff will show that the various schedules of the act are full of headings which are printed in small capitals followed by a dash or colon.

They claim that as the Circuit Court has arrived at this conclusion in an opinion containing such plain errors as have been already pointed out, and the Circuit Court of Appeals has at the hearing of the appeal affirmed the judgment on that decision it is not unreasonable that merchants should ask, and that the Supreme Court in the exercise of its discretion should grant, a hearing on this important question in the court of last resort.

It is expected that a decision will be handed down about the 18th of the present month.

The old established firm of A. Wallach & Co. have removed their offices from 30 Maiden Lane to Room 8, Lorsch building, 37 and 39 Maiden Lane, New York. This firm, now composed of L. Rosenberger and M. Rosenberger, have been in business as manufacturers of fine gold chains for half a century.

<b>W A T C H</b>	<b>GOLD FILLED.</b>	<b>C A S E S</b>
		

ESTABLISHED 1849.

INCORPORATED 1890.

### J. BRIGGS & SONS CO.,

MANUFACTURERS OF

## Gold and Silver Plate and Seamless Wire,

65 CLIFFORD STREET, PROVIDENCE, R. I.

WE MAKE

STOCK FOR

CANE HEADS,  
UMBRELLA MOUNTINGS  
PENCIL-CASES,  
WATCH-CASES,  
WATCH-CROWNS,  
THIMBLES,  
SPECTACLE AND  
EYE-GLASS BOWS,  
DIAMOND MOUNTINGS,  
&c., &c., &c.



## Send now

for our beautiful illustrated catalogue and ask for trade discounts. The time for Wedding Presents is here. As Birthday Gifts these beautiful statuettes are always salable. Over 40 subjects to select from. Prices from \$6.00 to \$20.00. The above group "Rip Van Winkle on the Mountains," (for which Mr. Jos. Jefferson posed in person) lists at \$10.00.

**Rogers Statuette Co.,**

441 Pearl St., N. Y.

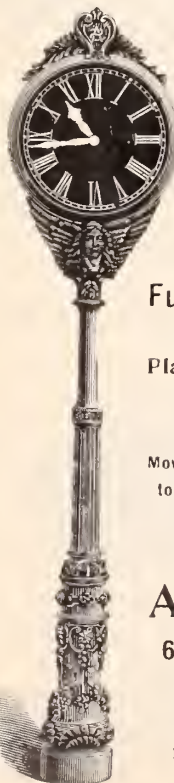

## Iron Pole Clock,

All of Iron and Sheet Metal.

Full Height, 15 Feet.

Plate Glass on both sides  
37 inches.

Movement between the two Dials  
to be wound every (2) two weeks.

MADE BY

**A. STAIB,**

668 W. Lexington St.,  
BALTIMORE, MD.

PRICE, \$250.00.

## Providence.

All communications for this column addressed to P. O. Box 1093, Providence, R. I., will receive immediate attention.

Thomas W. Lind has purchased real estate on Lyon Ave., East Providence, for \$1,500.

The directors of the Manufacturing Jewelers' Board of Trade will hold a meeting on the 16th inst.

Linton & Co., gold and silver platers, have removed from 54 Page St. to 95 Pine St.

J. G. Fuller & Co. are preparing to remove their factory from 129 Eddy St. to the Kent & Stanley building.

John W. Capron, traveler for George H. Holmes & Co., was recently married to Mrs. Wilhelmine J. Bateman.

Morris Pfaelzer, Philadelphia, Pa., is expected in town in a few days on his semi-annual visit to the manufacturers.

A. L. Sweet is temporarily located at 95 Pine St., where he is engaged in getting out a line of plated rings and novelties.

J. R. Feeley & Co. have re-started in business at 95 Pine St., manufacturing medals, emblems and ecclesiastical goods.

E. Biber, 561 Pawtucket Ave., Pawtucket, has given up the manufacture of optical goods and entered the employ of a Providence firm.

George Hamilton, for many years with E. H. Reynolds Co., has started in business as hub cutter, die sinker and tool maker at 95 Pine St.

Among the estates advertised by the City Treasurer, at Collector's sale for taxes due and unpaid, is the following: Wood, Bicknell & Potter, estate on Walker St., taxed for \$21,932.

David J. White, secretary of the Standard Seamless Wire Co., Pawtucket, left Monday last for Colorado Springs and Cripple Creek on business. He will spend several days at the mines.

Manufacturers in this vicinity have received information that Morris Lewis, New Orleans, La., is asking for an extension. Eastern manufacturers are interested for between \$5,000 and \$7,500.

Real estate belonging to Charles H. George, who recently assigned, situated on Somerset and Pine Sts., will be sold at mortgagee's sale on the 23d inst., and an estate on Clifford St. will be sold in similar manner on the 25th.

After a successful business career of more than three decades, the well known gold platers E. H. Reynolds Co., have decided to discontinue business. The concern was established in 1864 by E. Halsy Reynolds, with Jeremiah Briggs, now a living member of the J. Briggs Co., as a silent partner. Mr. Reynolds continued the business until his death in 1878, when the business was conducted for the benefit of Mr. Reynolds' heirs by William F. Andrews and his son. In 1890 the present company were incorporated with William Andrews 2nd and George E. A. Knight as the officers. When Mr. Knight withdrew in 1894, George Hamilton became interested.

The silver trophy offered by *The Telegram* for the winning club in the annual road race this month is a handsome piece of silverware. It has been exhibited by F. A. Knowlton '437

## The Attleboros.

Streeter & Bennett have commenced the manufacture of rolled plate chains in the shop of Streeter Bros.

Riley, French & Heffron have removed their New York office from 14 Maiden Lane to the Prescott building, 65 Nassau St.

A new manufacturing jewelry concern has been organized here with Walter B. Allen, Henry Thurston and Frank Smith, as partners.

A number of the manufacturing jewelers of this vicinity left here the past week on their annual fishing and hunting trip to Moosehead Lake, Me.

William Saart has been engaged as foreman at J. E. Blake & Co.'s factory to fill the vacancy made by the resignation of Frank Smith, who has gone into business for himself.

T. I. Smith & Co. obtained a judgment of \$6,378.52 against E. Wertheimer & Co., New York, last week and W. H. Wilmarth & Co. obtained one for \$371.04 against the same concern.

Postmaster Sweeney, of the Attleboro office, one day the past week sold 40,000 postage stamps to one manufacturing jewelry concern in town. The postage of this one firm often reaches \$500 a month.

A number of the business men of this vicinity met Wednesday evening in the Bates building to consider ways and means for the erection of a large factory building for the Mossberg Mfg. Co. The matter was thoroughly discussed, but nothing definite was decided upon.

The Attleboro *Sun* says: "A new gas-making machine is being exhibited at W. H. Wilmarth & Co.'s building. The company has been organized with E. B. Bullock as president and A. R. Crosby as treasurer, and these two gentlemen, with C. H. Tappan, D. E. Makepeace and M. E. Rowe are directors."

Charles A. Decker, New York, representing as counsel the firm of Lincoln, Bacon & Co., was in town last week obtaining signatures of the creditors of that concern to the recent proposition made by James D. Lincoln. He has met with unvarying success in his work among the creditors, and there is hardly any doubt now of a settlement being reached.

## Worcester, Mass.

As an outcome of the Hall vs. Caron lawsuit, which resulted in a victory for A. B. Hall, a new store has been opened at 19 Front St. under the firm name of A. B. Hall & Co.

At the first of the season shoot of the Worcester Gun Club, A. B. F. Kinney was first with a score of 27 out of 30 birds. In another event he scored 9 out of 10 birds.

Main St. The cup was especially designed for Mr. Knowlton, on order of *The Telegram*, by the chief designer of the Derby Silver Co., of Derby, Conn. The cup is lined with gold, and rests on a silver base 2½ inches high, the cup itself being 20 inches tall. On either side of the cup are round bases of silver, each supporting the figure of a bicycle, by the side of which stands the figure of a young man in full bicycle costume. The bases or pedestals like the main body of the cup itself, are lacquered finish, while the figures of the men and the wheels are of oxidized finish.

**Rochester, N. Y.**

Ellery Handy has recently fitted up a much handsomer room a few doors from his former location on State St.

E. B. Steel, late with McAllaster & Humburch Bros., has gone to Phelps, where he has bought the store of E. M. Cox & Son.

The case of Reed & Barton against Thomas F. Ashe and others was placed on trial before Justice Dunwell in Trial Term Wednesday. The action is brought to recover \$531 balance on account. Some time ago Ashe moved for the appointment of a receiver for the business, but the Smythe brothers bought him out. The debt to the plaintiffs was contracted before this time, but Ashe claims that he should not be compelled to pay the debt, as the Smythes assumed it when he sold out. The court directed Ashe to pay Reed & Barton \$35.08.

**Canada and the Provinces.**

A. G. Russell, jeweler, Hamilton, Ont., was married a few days ago to Mrs. Sarah Cook.

A. B. Odell, Coaticook, Que., has assigned. A meeting of his creditors was called for the 11th inst.

W. A. Brown, Markdale, Ont., well known in connection with the jewelry trade, died on the 28th ult.

A. Goebel, Oxford, Ont., has sold his busi-

ness to Charles Wendt, Mildmay, Ont., and opened a new store in Mitchell.

Owing to the death of W. H. Pollock, Winnipeg, Man., the firm of W. H. Pollock & Co. has been re-organized under the firm name of Fowler & Co.

Frederick Baker, formerly in partnership with his father in the jewelry business in Parry Sound, has commenced business on his own account as an optician in that town.

Mr. Stowe, of the W. H. Wilmarth Co., Attleboro, Mass., called on the trade in Toronto last week. Among other recent visitors were: R. H. Harris, Ansonia Clock Co.; A. R. Harmon, American Waltham Watch Co.

One of the finest amateur sporting championship prizes ever competed for in Canada is the gold cup presented by Hiram Walker, Walkerville, Ont., to the curling clubs of Toronto, as the trophy of the single rink championship. It is of 18 karat gold, about eight inches in height, vase shaped, and has two handles. It stands on an onyx pedestal with a base of ebony. It is a very elaborate piece of workmanship from a New York establishment. For some days it has been on exhibition in the store window of the J. E. Ellis Co., Toronto.

The Hemming Mfg. Co. have purchased the business of the Hemming Bros. Co., Ltd., Toronto, Can., including the plant, stock, book-debts, orders and good will. It is their intention to confine their energies strictly to the manufacturing of jewelers' cases and sundries and of regalia. The latter branch will be run separately as in the past under the name of the Dominion Regalia Co. The business will be under the management of H. K. S. Hemming who has been in charge of the Hemming Bros. Co., Ltd., since their inception. In addition to Mr. Hemming the company have obtained the services of Messrs. Rowland and Cole, both long and favorably known as the traveling representatives of the predecessors of the new company.

**New Jewelry Businesses.**

Lee Shoff, Coos, N. H.

Will Goebel, Victor, Ia.

J. W. Harris, Plymouth, Pa.

E. F. Mechler, Marshfield, Wis.

Claude B. Guthrie, Sylvania, Pa.

A. C. Sonthall, 273 Main St., Springfield, Mass.

Seaman & Lowe have opened their new jewelry store on State St., near 4th St., Hamburg, Pa.

T. S. Hoffman, who was in the jewelry business in Greensburg, Pa., for over 35 years, and more recently in business at Derry, Pa., has again opened up a new jewelry store at 4 W. Otterman St., opposite the Null House, Greensburg.

Frank Tyack, in the jewelry business a number of years with Peter S. Ermold, in Reading, Pa., has opened a jewelry store as agent at 760 Penn St. The place is neatly furnished. Mr. Tyack will make a specialty of diamonds, watches, engravings and repairing.

Fifteen hobos were held up in an incoming Lake Shore at Toledo, O., last week, in response to a dispatch from Stryker, O., asking for the arrest of two men who committed a burglary at that place and were supposed to have taken train for Toledo. The burglary was on A. F. Young's jewelry establishment, and the thieves got \$50 in cash and about \$350 in jewelry.

Herman C. Kachlein, Lafayette, Ind., has purchased property on the corner of South and 8th Sts.; consideration, \$4,000 cash. The lot is 50x180 feet, and is especially well graded for building purposes. Mr. Kachlein secures possession of the premises June 1, and will immediately thereafter commence the removal of the house now standing. He will then erect flats, either four or six, the structure to be of brick, and to face on South St.



**The Puritan**  
...is a...  
**Boston**  
**Wheel.**

ALSO MAKERS OF

**HECTOR**  
**BICYCLES,**  
**\$75.**

Factory Established in 1888

**It is High Grade**  
**Known as First Class.**

**WE GRANT AGENCIES ONLY TO JEWELERS.**  
**DISCOUNTS AND CATALOGUE ON**  
**APPLICATION.**

**The F. Kroeber Clock Co., 360 Broadway, New York.**  
Sole Agents for the Jewelry Trade.

### Last Week's Arrivals.

**THE CIRCULAR has perfected arrangements for obtaining the names and hotel addresses of all the latest buyers visiting New York, and each day posts in its office, 189 Broadway, a bulletin which every member of the trade is cordially invited to copy.**

The following out-of-town dealers were registered in New York during the past week: L. C. Reisner, Lancaster, Pa., Astor H.; A. T. Maynard, of A. Stowell & Co., Boston, Mass., Holland H.; W. H. Glenny, Buffalo, N. Y., Murray Hill H.; A La France, Elmira, N. Y., Gilsey H.; N. Plaut, Cincinnati, O., Savoy H.; Miss C. Green, Chicago, Ill., Holland H.; J. D. Kohns, Philadelphia, Pa., Vendome H.; Miss S. Mayor, Washington, D. C., Metropole H.

### Trans-Atlantic Voyagers.

#### TO EUROPE.

E. L. Furber, Chicago, Ill., J. Muhr, of J. Muhr & Bro., Philadelphia, Pa., and Maurice L. Power, of Power & Mayer, New York, were passengers on the *Majestic* which sailed Wednesday.

A. Peabody, New York, and Abe Hirschberg, of Hirschberg Bros., New York, sailed Wednesday on the *New York*.

J. H. Beveridge, Washington, D. C., H. Schenkein, of H. Schenkein & Sons, New York, and Mr. and Mrs. Von Wezel, New York, sailed Saturday on the *Lucania*.

Edw. A. Jeanneret, Chicago, Ill., sailed Saturday on *La Bourgogne*.

#### FROM EUROPE.

Among the passengers on the *Normannia* which arrived Friday were: Henry Froehlich and Henry Froehlichstein, of Henry Froehlich & Co., New York; Edw. Van Dam, New York; Chas. J. Kuhn, of Kuhn, Doerflinger & Co., New York, and Chas. T. Dotter, New York.

Frank Jeanne, of Wm. S. Hedges & Co., New York, arrived on the *Euraria* May 9.

### Receiver Appointed for the Gustav Walter Optical Co.

Gustav Walter was on Friday appointed temporary receiver of the Gustav Walter Optical Co., 12 John St., New York, by Judge Prior, of the Supreme Court. A previous order had summoned all persons interested in the company to show cause before Eugene Durnin, 20 Nassau St., on Aug. 4, 1896, at 10.30 o'clock A. M., why the corporation should not be dissolved and a permanent receiver appointed. Both orders were granted on the petition of Gustav Walter, Theodore E. Studley, Gustav A. Walter and James M. Bloomfield, directors of the company, in proceedings for the voluntary dissolution of the corporation.

The petition of the directors shows that the business greatly depreciated during the past two years, and that a large quantity of stock

has not been salable, except slowly and in small lots, and that new goods necessary to maintain business could not be procured. The corporation have steadily lost money and one of their notes has gone to protest. A recent examination of the property by a committee of stockholders, disclosed the fact that there was not sufficient assets to pay all just debts and a subsequent effort by the officers to raise additional capital proved unsuccessful. At a meeting of the larger creditors held April 23d, it was unanimously agreed that the company dissolve and a receiver be appointed. The company's total liabilities amount to about \$16,000, while the nominal assets are about \$14,600.

The principal merchandise creditors are: A. Berger, \$3,386; Standard Optical Co., \$753; Bausch & Lomb Optical Co., \$188; Gustav Walter, \$693; E. C. Boardman (rent) \$525. The Standard Optical Co. also hold notes for about \$2,600 and the Chatham National Bank for \$7,500. The assets consist of safe and fixtures valued at \$500; stock valued at \$12,622.91; and outstanding accounts of \$1,474.23.

### Diamond Ornamented Gloves.

A TOURIST, recently returned from Paris, says that the jewelers of that city seem to be in a fever, in their endeavors to bring out new and striking designs, to satisfy

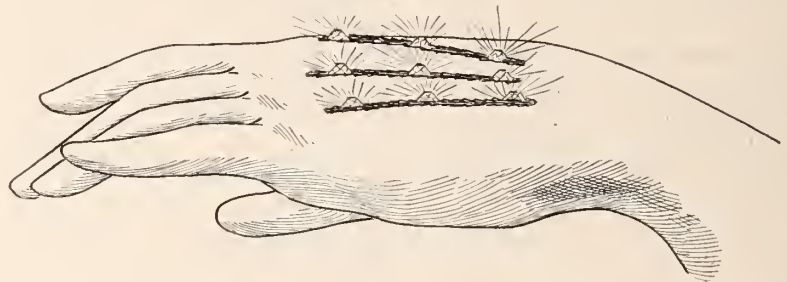

the great demand for expensive jewelry. The wearing of gems has never been so wide-spread and so extensive; not only are all the established varieties of jewels worn but precious stones are being put to numerous uses in the decoration of articles of dress. It is not uncommon to see even the gloves of an *élégante* ornamented with diamonds as in the accompanying illustration. The diamonds are in settings kept in position on the ribs by means of nut attachments.

#### Syracuse.

S. W. Percy, Ogdensburg; C. J. Fuller, Phoenix; and Dell Onderkerk, Baldwinsville, were in town last week replenishing stock.

C. E. Eager is now in full possession of his new store at 229 S. Warren St., having removed the first of last week from his former location, at the corner of S. Salina and E. Genesee Sts. The store has been thoroughly renovated and re-decorated, and presents a dainty appearance.

H. J. Howe's new store in the White Memorial building, is still in the hands of the decorators, who are working some decided

changes. Being forced to move from his old store on account of the demolition of the Syracuse House block, which was commenced on Tuesday, Mr. Howe has been unable to open in his new location, but the close of the week will undoubtedly find him fully established.

The next stated meeting of the Optical Society of the State of New York will be held at the Yates hotel, this city, on the evening of June 2. The meeting will be full of interest to all opticians and dealers in optical goods. The Society has an enrolled membership of over 100 and it is expected that a large delegation from New York city will be present. S. M. Shimberg, of the Syracuse Optical Co., has been named as chairman of the press committee and will choose his associates. He was the means of bringing the meeting to this city. It was desired by Albany, Binghamton, Rochester, Buffalo and Utica.

Among the jewelry salesmen noticed in Syracuse the past week were: Charles A. Foa, Jos. Friedlander & Bro.; G. B. Osborn, Wm. Smith & Co.; Jas. P. Ward, Wendell Mfg. Co.; Mr. Shute, Day, Clark & Co.; Edward M. Ross; Haviland & Co.; P. M. Layman, Riker Bros.; J. J. Hawkes, Hayden W. Wheeler & Co.; Frank G. Moyer, American Watch Case Co.; E. H. Cox, Sussfeld, Lorsch & Co.; Wm. C. Solomon; Alex. Levin, for Max Nathan; S. Glenn Walmsley, Tenner & Baum; C. C.

Rosenberg, Henry Terhune & Son; C. W. Marble, the Acme Silver Plate Co.; Mr. Ford, Baldwin, Ford & Co.; E. Horton, J. B. Bowden & Co.; Mr. Thompson, Sinnock & Sherrill; Mr. Knowlson, Bioren Bros.

E. C. Putnam has bought out W. H. Wiesman, Elm St., Worcester, Mass.

Geo. W. Sayer, Spencer, Mass., who recently assigned, has leased one of the vacant stores in King's block, and will again engage in the jewelry business.

E. B. Jewett, assignee of Leo Lesquereux, Columbus, O., has sold the latter's stock to Mrs. Anna M. S. Earhart for \$1,893.15, the appraised value, and the Probate Court has confirmed the sale.

The police of Reading, Pa., have in custody Edward W. Tourey, who refuses to talk and cannot be induced to explain how he obtained a large lot of alleged stolen goods. Among other things 75 gold watch chains were found on his person. He was arrested after a fight with Philadelphia and Reading Special Police-man Wartman, and is now in jail.

**Philadelphia.**

President Sackett, of the Jewelers' Club, was in New York on business Friday and Saturday.

Jacob Muhr, R. Pinkstone and Louis Sickles were among the Philadelphians who left for Europe last week.

Judge Ashman made perpetual the injunction granted Mrs. Rebecca J. Borhek, in the management of the optical business of her late husband.

Louis Bedichimer, a son of Isaac Bedichimer, has opened a bicycle agency, but the business is entirely separate and apart from the jewelry enterprise.

The Keystone Watch Case Co. have begun proceedings through their attorney, A. B. Duvall, to recover a judgment creditor's bill of \$4,000 and interest, against S. Willard Saxton and others, Washington, D. C.

Syl. A. Schmitt, Jr. & Co. have dissolved. Mrs. Jane E. Davis, mother of Rem. P. Davis, deceased, will continue this business at 116 S. 12th St, under the name of J. E. Davis, William Mohr and E. Cashmore acting as managers.

B. C. Foster, Bristol Pa.; R. S. Porter, Woodbury, N. J.; C. F. Rudolph, Wilmington, Del., H. E. Thomas, Wilmington, Del., A. Doran, Mt. Holly, N. J.; S. F. Stover, Perkasio Pa., and Howard Fitzsimmons, West Chester, Pa., were in the city last week on purchasing expeditions.

Dr. Walter H. Keyes, who claims to be president of the "Mississippi Medical Company of New York," was arrested in this city May 8th on a charge of larceny as bailee of \$150. The prosecutor was Harwood Ayres, Delaware City, who alleged that he answered an advertisement inserted by Dr. Keyes for a salesman in a jewelry store. On May 9th the defendant had a hearing before Magistrate Jermon. Ayres said that after meeting Dr. Keyes they opened an office at 7th and Sunson Sts. Here the physician displayed a lot of cheap watches and so-called diamond rings which were reported as having been secured for money advanced by the doctor. It was stated that the goods could be disposed of for one-half their real value and at the same time from \$10 to \$15 could be made on each sale. Ayres was engaged by the physician as salesman and the doctor secured a check for \$150 by giving him as security a deed for 150 acres

of land in Dunklin County, Missouri. Dr. Keyes vanished subsequently and Ayres complained to the police, saying that he had been swindled. The doctor's arrest soon followed. It was learned that Ayres and Dr. Keyes had formed an agreement the time limit of which does not expire for two weeks, so that the prosecution could not be properly supported. A compromise was effected and Dr. Keyes thought that he was about to regain his freedom when he learned that he was to be detained on another charge. He is wanted in Allegheny City on a charge of obtaining money by false pretenses and he will be sent there for trial.

**Boston.**

Henry M. Patterson, of Smith, Patterson & Co., has returned from his California outing.

Frederick B. Chase, dealer in material, was in New York on a buying trip during the past week.

Letters received from Willard Harwood note the safe arrival of himself and party in Europe.

Treasurer W. A. Bates, of the Ripley-Howland Mfg. Co., has been confined to his home the past week by illness.

J. B. Humphrey, dealer in and cutter of diamonds and other precious stones, has been in New York during the week on a buying trip.

Samuel J. Byrnes, for a number of years with Wilson Bros., has severed his relations with that firm and embarked in the real estate business in this city.

The vacation season is beginning early this year in the Boston trade. Eugene Sanger, salesman for Harwood Bros., is on an outing trip in Maine, and Charles G. Perry, salesman for the Ripley-Howland Mfg. Co., started this week on a vacation trip to St. Louis by way of the Lake cities, and will return by way of Cincinnati and Pittsburgh.

In the Superior Court last week, the Judge before whom was tried the suit of ex-supt. W. B. Learned, of the E. Howard Watch & Clock Co., set aside the verdict rendered in his favor for \$1,123 by the jury, on the ground that it was contrary to the law and evidence, and allows Mr. Learned only \$80, the sum which the company contended was all that was due him.



**BATES & BACON**  
"FAVORITE"  
14K



**BATES & BACON**  
"ROYAL"  
14K



**BATES & BACON**  
"PURITAN"  
14K

**ALWAYS**

Ask to see  
our

**GOLD FILLED  
WATCH CASES.**

**None Better**

and

**Few Equal.**

**To Dealers  
Only.**

**FISHING**



**SPLIT BAMBOO RODS,**  
From \$10.80 per doz.,  
to \$76.50 each.

**ALL LANCEWOOD RODS,**  
From \$9.90 per doz.,  
to \$3.00 each.

136 page Catalogue Free.  
Send for it.

**ABBEY & IMBRIE,**  
21 VESEY ST.,  
New York.

**TACKLE.**

A Western customer writes under date of March 25, 1896: "The time for making Class Pins is approaching and we have had several calls this week. Please send us circular of your very *Latest Designs in Class Rings* and quote prices and we will make an effort to get some orders."

Requests for "up-to-date" Designs *promptly* sent to Jewelers with estimates.

**Henry C. Haskell,**  
**MAKER,**  
11 John St., New York.

**A. J. COMRIE,**  
**AUCTIONEER,**  
22 John St., N. Y.  
SPECIAL SALESMAN OF WATCHES, DIAMONDS,  
BRIC-A-BRAC, FOR ESTABLISHED JEWELERS.  
WRITE FOR PARTICULARS

WE CATER TO THE JEWELRY AND STATIONERY TRADES ONLY.

**ALFORD & EAKINS,**

Successors to Henry G. Alford 73 Nassau Street, New York.

ENGRAVERS, PRINTERS and EMBOSSERS,

Manufacturers of fine Wedding Invitations,  
Reception and Calling Cards, etc, etc,

All our work is guaranteed to be fully  
equal to our samples which are second to  
none.—Send for them.



### Court Asked to Review the Administration of the Estate of E. J. Cuendet.

St. Louis, Mo., May 7.—A suit was brought in the Circuit Court yesterday by Dr. Wm. C. Richardson, the Public Administrator, to review the doings of the late Eugene J. Cuendet, as one of the administrators of the partnership estate of Eugene Jaccard & Co., on behalf of Uranie Cuendet, Louis Cuendet, Eugene Cuendet, Gastar Cuendet, Eliza Cuendet, Henrietta Cuendet, Helene Montandon, Louise Jaccard, wife of Paul Jaccard, Fannie Caulern, wife of F. Caulern. The petition accompanying the suit alleges wholesale fraud on the part of the late Eugene J. Cuendet, and the suit seems to be brought in the hope that Uranie Cuendet's heirs will be benefited, she having died last Summer.

The object of the suit is to review all Cuendet's doings as administrator, so as to set them aside and to restore to the heirs of Uranie Cuendet their right to one-half of Eugene Jaccard's estate. The bill was filed by E. T. and C. B. Allen. Eugene J. Cuendet, the executor of the estate of E. Jaccard, was a nephew of that gentleman, and a son of Mrs. Uranie Cuendet.

Eugene Jaccard died in 1871, leaving as heirs his wife, Henrietta, and his sister, Uranie Cuendet. Eugene J. Cuendet and Henrietta Jaccard were appointed administrators; and Dr. Richardson asserts that Cuendet assumed full control of the administration, and persuaded the widow to assent to all that he did. He was permitted to have full charge of the co-partnership business of Eugene Jaccard & Co., and of Eugene Jaccard's individual estate, and the result was, according to the petition, that he so complicated the assets as to make it appear in April, 1874, that the partnership owed him \$135,378. This result was reached by his giving himself credit for \$139,157 alleged to have been paid to the creditors of the estate. He, it is alleged in the petition, fraudulently charged other sums to the estate, so that as a result of these "fraudulent devices" he made it appear that Eugene Jaccard's individual estate owed the administrators \$214,441, whereas, right bookkeeping would have shown a small balance to the credit of the estate, the petitioner says. Mr. Cuendet's manipulation of the real estate belonging to Eugene Jaccard is also criticised.

Thomas D. Witt, president of the E. Jaccard Jewelry Co., declared when interviewed, that

the action must have been done through malice. Mrs. Uranie Cuendet, he said, had died in Europe last Summer, leaving a number of heirs, some of whom lived in Europe and others in this country. Eugene R. Cuendet is her only heir living in this city, and Mr. Witt showed that a suit could not have been instigated by him, as he is the direct heir of Eugene J. Cuendet, and would be the loser should the allegations against his father prove true. Furthermore, Mr. Witt said the executors of Mrs. Uranie Cuendet's estate were appointed in Switzerland, and so far as he knows everything has been settled. He is of the opinion that some disgruntled heir imagines that Mrs. Uranie Cuendet had an interest in the E. Jaccard Jewelry Co., and placed the matter in Dr. Richardson's hands, at the same time instructing him to bring suit against Eugene J. Cuendet as being the only way to recover.

"Eugene J. Cuendet, as executor for the late Eugene Jaccard," said Mr. Witt, "closed up the latter's estate some twenty years ago, and even if the allegations in the suit are proven, I can not see what will be gained. As near as I can recollect the estate was closed about 1874 by Mr. Cuendet, and if I remember correctly he was at that time discharged by the Probate Court. No dissatisfaction with Mr. Cuendet's so-called manipulation of affairs was heard at that time, or up to the time of his death in May, 1894, and so the suit looks to me very much like malice on the part of persons unknown. I was appointed executor of the estate of Eugene J. Cuendet at the time of his death, and just the other day I advertised that the estate left by him would be closed up on June 12th. He, as executor of E. Jaccard's estate, probably did the same, and nobody appearing to protest against such action shows that there was no dissatisfaction at that time at his management of affairs. I can only repeat that it appears to me as if the suit was brought out of pure spite work."

Mr. Steinmeyer, of the E. Jaccard Jewelry Co., said when seen by THE CIRCULAR representative that each one of the parties who brought the suit was a beneficiary to the amount of \$30,000, and that they waited until they had received the money and issued receipts in full before they filed the suit, which goes to show, he said, that they must have thought the estate belonged to Mr. Cuendet before they filed it.

### Receiver for the Firm of Newwitter & Rosenheim.

The firm of Newwitter & Rosenheim, wholesale jewelers, 513 Broadway, New York, went into the hands of a receiver Saturday. Judge Truax, of the Supreme Court, appointed Philip Rosenheim receiver of the firm with the usual powers, and placed his bond at \$10,000. The appointment was made in an action to dissolve the firm, brought by the senior member, Morris J. Newwitter, against David Rosenheim, his partner.

In his complaint Newwitter states that the partnership was formed in 1876 and the time originally limiting its duration has long since expired. The firm have lately suffered severe losses arising from depreciation of stock, losses on outstanding accounts and large expenses. The assets have also been impaired by other causes and there is not sufficient to pay the liabilities. The firm, he declares, are wholly insolvent. A large number of debts are now maturing and the concern are liable to be sued. The complaint says that the partners cannot agree as to the manner of liquidation and ask judgment that the partnership be dissolved and a receiver appointed. The order appointing the receiver was entered by consent of both partners.

Newwitter & Rosenheim have been in business 20 years as jobbers of cheap jewelry. Their merchandise indebtedness is principally in the east. The firm's total liabilities are said to be from \$80,000 to \$90,000. No statement as to the assets has yet been obtainable.

### Proceedings of the Jewelers' League.

The regular monthly meeting of the executive committee of the Jewelers' League was held on Friday, May 8th. There were present Vice-Presidents Bardel, Greason and Untermeyer, Chairman Van Deventer, Messrs. Karsch and Street and L. Stevens, Jr., secretary. The minutes of the previous meeting were read and approved.

Eight requests for change of beneficiary were received and upon motion granted and the following nine applicants were admitted to membership:

Section A.—Edward R. Barnes, Boston, Mass., recommended by B. B. Savary and J. M. Clisham; Chas. S. Ellis, Toronto, Canada, by M. C. Ellis and B. G. Wilkinson; Z. A. Oppenheimer, New York, by M. Veit and M. Sachs; Chas. E. Patterson, Chicago, Ill., by G. C. A. Greyer and H. R. Greyer; Louis E. Smith, Brooklyn, N. Y., by W. A. Wightman and E. V. Clergue.

Section B.—Edgar L. Brown, Jersey City, N. J., by E. V. Clergue and W. A. Wightman; Moses Loeb, Chicago, Ill., by S. Kaiser and A. W. Schwab; Glenn W. Morgan, Winona, Minn., by S. W. Morgan, G. B. Stager and A. Martin; and Wm. K. Robinson, Pensacola, Fla., by W. F. Williams and W. A. Dalenbach.

Upon motion the meeting adjourned. The next meeting of the executive committee will be held June 5, 1896.

Purses and card cases of Java lizard divide favor with those articles in monkey skin.

**A. WITTAUER,**  
SUCCESSOR TO  
**J. EUGENE ROBERT & CO.,**  
IMPORTER AND MANUFACTURER OF  
PLAIN AND COMPLICATED

WATCHES AND  
WATCH MOVEMENTS,  
19 Maiden Lane, New York.



# The Jewelers' Circular

AND  
HOROLOGICAL REVIEW.

PUBLISHED EVERY WEDNESDAY BY

THE JEWELERS' CIRCULAR PUB'G CO.,

189 BROADWAY, NEW YORK CITY.

A JOURNAL DEVOTED TO THE INTERESTS OF JEWELERS, WATCHMAKERS, SILVERSMITHS, ELECTRO-PLATE MANUFACTURERS, AND ALL ENGAGED IN KINDRED BRANCHES OF INDUSTRY.

Member of the American Trade Press Association.

Our Editorial columns will contain our own opinions only, and we shall present in other columns only what we consider of interest or value to our readers. Advertising matter will not be printed as news.

Advertising rates in THE CIRCULAR are lower, considering the number of tradesmen reached by its large circulation, than in any other jewelry journal.

Notices of changes in standing advertisements must be received one week in advance; new matter can be received up to Monday.

## INFORMATION FOR SUBSCRIBERS.

### Terms of Subscription, Postage Prepaid.

United States and Canada, . . . . .	PER ANNUM.	\$2.00
Foreign Countries in Postal Union, . . . . .		4.00
Single Copies, . . . . .		.10

New Subscribers can commence at any time.

Payments for THE CIRCULAR when sent by mail, should be made in a Post-Office Money Order, Bank Check or Draft, or an Express Money Order or Registered Letter. All postmasters are required to register letters whenever requested to do so.

Pay money only to authorized collectors having proper credentials.

**Returning Copies** Returning your paper will not enable us to discontinue it, as we cannot find your name on our books unless your address is given.

**Changing Address.** In changing address always give the old as well as the new one. Your name cannot be found on our books unless this is done.

**Discontinuances.** We will continue to send papers until there is a specific order to stop, in connection with which all arrearages must be paid; but such an order can be given at any time, to take effect at or after the expiration of the subscription. All such orders will be promptly acknowledged by mail.

**Liability.** The Courts have decided that all subscribers to Journals are responsible until arrearages are paid in full and an order to discontinue has been received by the publisher.

## THE JEWELERS' CIRCULAR IN EUROPE.

Among the Places in Europe where THE JEWELERS' CIRCULAR is on file are the following:

**LONDON**—First Ave. Hotel, Holborn, E. C.; Holborn Viaduct Hotel, Royal Hotel.

**PARIS**—Hotel de L'Athénée, Rue Scribe.

**BERLIN**—Deutsche Uhrmacher Zeitung, Jager-Strasse, 73.

**GENEVA**—Journal Suisse D'Horlogerie.

**AMSTERDAM**—Continental Club, Hotel Amstel.

**ANTWERP**—Diamond Club, Rue de Pelican.

Vol XXXII. May 13, 1896. No. 15.

Every line of reading matter in THE JEWELERS' CIRCULAR, with the exception of the few brief extracts from exchanges, always properly credited, is written exclusively for this journal. Each issue of THE JEWELERS' CIRCULAR is copyrighted. Permission to quote is extended to other publications, if such quotations are properly credited.

## Jewelry Fashions and Jewelers' Advertising.

SOME members of the trade who are interested in the progress to the industry have noted, from time to time, a tendency on the part of the daily newspapers throughout the country to publish articles decrying the wearing of jewelry or announcing the death of certain long established fashions in the jewelry line. The jewelers have appreciated the great harm done to the trade by the publication of such articles, and have called upon THE JEWELERS' CIRCULAR to exercise its influence to counteract the effects of these penny-a-liners' effusions. This journal has done all it can to lead the public into the right path, by publishing from week to week an accurate review of current fashions in jewelry and kindred lines, which is widely quoted in the columns of the daily and weekly newspapers throughout the Union. We have learned, however, that the causes of the publication of the unreliable and often scurrilous fashion articles in the public press, referred to, are created by the jewelers themselves though they are immediately dictated by revengeful and splenetic impulses in the minds of the fashion writers. It appears that in the visits to the jewelry stores and factories, these newspaper representatives are treated with little courtesy, the jeweler often absolutely refusing to show his lines, or at the best showing them only a few old patterns, being apparently afraid to display anything new or novel. In the language of these writers they feel that they have been "turned down" and retaliate by composing articles detrimental to the interests of the jewelers. It would be but the part of a fair minded man if he would treat with courtesy these emissaries of the press, and if he is so much afraid of his neighbor, as to refuse to show them some special or unique novelty, at least let them obtain a comprehensive knowledge of up-to-date styles and patterns and allow them no room for inferring that nothing new in jewelry is produced because nothing is wanted.

We are convinced, as we have frequently made manifest in these columns, that one of the greatest deterring forces in the jewelry trade is the cowardice evinced by jewelers in general in hiding everything new that is produced unless it is protected by patent. Not only is this true of the wholesale and manufacturing branches of the trade, but the fact is as clearly apparent among the retailers, who in their announcements to the public, use general terms and platitudes which mean little to anybody and convince nobody. Their fulfillment of correct ideas in their display advertising and their eager willingness to accept all the free advertising offered them in the way of fashion articles and descriptions of new goods are among the potent factors that have placed the department stores in their present threatening position in relation to the retail jewelry trade. The jewelers should adopt the same principles of business, and be no longer afraid of those pillagers of intellectuality, whose plunder con-

sists of other people's ideas, patterns, designs, etc. These pillagers thrive in every industry, and no barrier can be set up between the object of their desire and their Roentgen-photographic-process-like eyesight.

THE practice of donating silver services to the new war vessels of the United States Government, by the cities or States in recognition of the honor conferred upon these cities or States in the naming of the vessels, has become deep rooted throughout the Union. THE CIRCULAR this week shows the design accepted by the authorities of the city of Nashville, Tenn., for the service to be presented to the cruiser *Nashville*, and announces that the city of Portland, Ore., is accumulating a fund to defray the cost of a service to be given the *Oregon*. This journal has in previous numbers devoted considerable space to descriptions and illustrations of the designs of the services presented to the *New York*, *Brooklyn*, *Chicago*, *Cincinnati*, *Detroit*, *Minneapolis*, *Indiana* and *Maine*. Though it may be said that this practice is a circumstance producing especial benefits to the silversmithing industry, it is nevertheless founded on true patriotism, sound sense, and aesthetic instinct; for these services are not only objects of common utility, but they possess the elements of fine art, and are productions of a distinctly American industry, of whose achievements Americans should be proud.

## Creditors' Committee of Harland G. Bacon Make Report.

PLAINVILLE, Mass., May 9.—The affairs of Harland G. Bacon have reached that stage where the creditors' committee appointed April 8th having examined the concern's accounts, are in a position to submit an exhibit of what the books say in the inexorable language of plain figures. This failure is the largest that has ever occupied the attention of the business men in this section, and the effects of it upon the community where Mr. Bacon was engaged in business is far-reaching.

The committee completed their labors and late this afternoon sent out the result of their findings in a report. The report issued to the creditors without recommendations begins as follows:

"To the creditors of Harland G. Bacon, Plainville, Mass.: The committee chosen at your meeting, held on April 8, 1896, to examine into the financial condition of said debtor, find his affairs to be so intermingled with those of Lincoln, Bacon & Co., Wade, Davis & Co., and others, that it is nearly impossible to arrive at a full and accurate result as to his actual total liabilities. The real estate has been examined by your committee, and though in several instances changes have been made, the total valuation varies but little from that placed thereon by the appraisers for the assignee.

"Mr. Bacon's individual one-half interest in the tools and machinery of Lincoln, Bacon & Co. has been eliminated entirely from the

list of his assets; and, as it is the unanimous opinion of your committee that Lincoln, Bacon & Co. hold the legal title to the 'factory property,' they have placed the interest claimed therein by Mr. Bacon, among the assets marked 'doubtful.' The following is the result of your committee's investigation:

Total assets.....\$ 51,395.00  
Total liabilities..... 144,968.40"

#### Luigi Zalli, Alleged Smuggler, Acquitted.

TRENTON, N. J., May 8.—In the United States District Court, Monday, Luigi Zalli, a jeweler, of New York, who keeps a Summer jewelry store at Saratoga, was tried on a charge of smuggling jewelry and similar valuables into the United States. The jury, after being out but a few minutes, brought in a verdict of not guilty, the defendant being represented by Ullo, Reubsamen, Cochran & Baldwin, of New York.

The witnesses called by the Government testified that the defendant brought to this country a trunk containing a quantity of jewelry and also a package of the same goods in his outside coat pocket. There was no invoice nor declaration of the contents of the package and trunk given to the revenue officials.

The defendant testified and admitted having had dutiable articles in his possession, but said that he had made no attempt to conceal them, nor had he any intention of avoiding the payment of duty, offering pay when the jewelry was discovered. He said that he had made a verbal declaration to the Custom House officers of the articles in his possession. A number of other witnesses testified to the good character of the defendant and to the circumstances of the case.

#### Important Notice to Those Who Favor National Bankruptcy Legislation.

The New York Jewelers' Board of Trade have sent to their members the following communication in reference to the National Bankruptcy bill:

"We are informed that the Bankruptcy bill (which is virtually the Torrey bill) that recently passed the House of Representatives, will shortly be taken up by the United States Senate, and that at a vote recently taken before the Senate Committee, the Hon. David B. Hill (we understand) voted against it, being under the impression that the business community of this State did not desire to have it passed. In view of this we would suggest that you write to Senator Hill, informing him of your views in the premises; and that it is the earnest wish of the business community, that the United States Senate pass this bill as soon as possible, and request him to cast his vote for that purpose.

"We would also suggest that you write to the Hon. Edw. Murphy, Jr., substantially to the same effect; for you will see it is very important that all our merchants use every effort possible in the way of influence, etc., towards the passage of the said Bill before the Senate adjourns.

The address of Hon. David B. Hill and Hon. Edw. Murphy, Jr., is Senate, Washington, D. C. Nearly all the other Associations, we are informed, have requested them to write these Senators in the manner above indicated.  
May 9th, 1896.

#### New York Notes.

J. Herzog & Co. recently removed from 8 Maiden Lane to 32 Maiden Lane.

A judgment against Francesco Volpe for \$255.31 has been filed by R. Friedlander.

Kirby, Mowry & Co. have entered a judgment for \$915.37 against A. H. Seyd & Co.

A judgment against Benjamin S. Wise for \$280.75 has been entered by Lewis, Kaiser & Luthy.

J. H. Caruss & Co., retail opticians, have removed their store from 332 Fifth Ave. to 5 E. 42d St.

A judgment for \$631.76 against Nathan S. and Wolf Kaplan has been entered by N. Whitman and others.

C. G. Alford, of C. G. Alford & Co., left last Saturday for a month's fishing at the Saranac Club, in the Adirondacks.

The Gorham Manufacturing Co. have satisfied a judgment for costs amounting to \$115.94 entered by Chas. Seale.

The sheriff's sale of the effects of A. H. Seyd & Co., 3 Union Square, took place Thursday and realized about \$200.

Ahrens & Adler, dealers in novelties and jewelry, have removed from 470 Broadway to the Lincoln building, 1 and 3 Union Square.

C. R. Bannihr has removed from 235 Canal St. to 196 Centre St., and has re-established his engraving and die-sinking business at the latter address.

Arthur Moeller, watchmaker, 20 John St., and Miss Louise E. Seidler, of Brooklyn, were married last week in Trinity Episcopal Church, Arlington Ave., by the Rev. Nelson R. Boss.

The wife of Solomon Cohn, a peddler of jewelry, and two of their three children were burned to death at 234 Johnson Ave., Williamsburgh, May 6th. Their clothing caught fire from a gas stove.

Cole Krabatz, 25 years old, a Pole, who had a little jewelry shop at 363 Madison St., committed suicide Wednesday night by poisoning himself with carbolic acid. Disappointment in love is said to have been the reason for the act.

The suit of Frederick Beltz against George Doerflinger and Fred'k Storm, came up for trial Wednesday in the Supreme Court before Judge Bookstaver, and resulted in a verdict for the plaintiff for \$2,890. Mr. Beltz, who was assignee of Kuhn, Doerflinger & Co., sued for the balance, which he alleged was due, of the amount to be paid him on his discharge as assignee.

Judge Townsend last week dismissed the complaint of Chas. W. Harmon, in his suit in the United States Circuit Court against Jos. Fahys & Co. and H. G. Skidmore. The suit alleged infringement of and asked an accounting on a patent improvement in watch movement boxes. Harmon and the defendant Skidmore were co-patentees of the improvement alleged to be infringed upon.

James O'Neill, who, as recently told in THE CIRCULAR, was arrested for being implicated

in the robbery at Turpisch's jewelry store, Stapleton, Staten Island, pleaded guilty May 4th, and Justice Kullman gave him 59 days in the County Jail, with a fine of \$30. His partner in crime, T. J. Hawthorne, as told in THE CIRCULAR last week, had been previously sent to the penitentiary for six months.

Henry Fera, importer of diamonds, 65 Nassau St., whose settlement with his creditors at 33 1-3 per cent. was announced in THE CIRCULAR April 29th, had his property re-assigned to him, Monday.

Word was received in this city Monday that the suits against the Coetermans-Henrichs-Keck Diamond Cutting Co., Herman Keck and Franz Von Reeth, at Cincinnati, O., would not be tried this month as expected, but would go over until the Fall. The actions are brought by the United States to recover \$1,000 for each diamond cutter alleged to have been imported under contract by the defendants in violation of the Contract Labor Law.

Michael Lang, 38 years old, a salesman, was arrested May 5th charged with grand larceny on a warrant sworn out by Joseph Green, jeweler, 426 Sixth Ave. The prisoner was held in \$1,000 bail. Green states that on Nov. 15, 1895, Lang obtained from him a pair of diamond earrings valued at \$236, and gave him a four months' note due on May 2d, in payment. The note went to protest and when Lang refused to surrender the earrings the jeweler caused his arrest.

A complete list of the firms who have taken offices in the new Lorsch building, 37-39 Maiden Lane, is as follows: Store floor, Sussfeld, Lorsch & Co. and L. W. Sweet; 1st floor, Sussfeld, Lorsch & Co.; 2d floor, A. Wallach & Co.; 4th floor, Jules Racine & Co. and S. Kohn; 5th floor, Albert Lorsch & Co. and Solomon Bros.; 6th floor, Low, Weinberg & Co.; Bugbee & Niles, E. I. Franklin & Co., H. C. Lindol, Barstow & Williams, Young & Stern, Martin, Copeland & Co., H. F. Barrows & Co., Fowler Bros., Regnell, Bigney & Co., and M. Hyams; 7th floor, Trier Bros., L. Witsenhausen, A. Peabody, R. Rheinart and Rees & Yankauer; 8th floor, Edw. Morro; 9th floor, J. Edw. Master, S. M. Lewis and F. Kohn.

Geo. W. Washburn, a former partner in the firm of Sexton Bros. & Washburn, started last week as a manufacturing jeweler with an office and factory at 194 Broadway. Mr. Washburn has purchased the entire plant of James F. Crandall, formerly of 51 Maiden Lane, which he has removed to his new factory. Mr. Washburn is well known throughout the jewelry trade, having been connected with it for over 40 years. For 20 years he was foreman for Randel, Baremore & Billings and left them to become partner in the firm of Sexton & Washburn and later Sexton Bros. & Washburn, which dissolved two years ago. Jewelry for precious stones will be the line to which Mr. Washburn will particularly devote his efforts. He is the inventor of a number of improvements in brooches, earrings and studs.



Traveling representatives may consider these columns open for the publication of any news or items of interest regarding themselves or their conferees.

**H. GRANBERY,** Cutler & Granbery, and T. Hopkins, Meriden Silver Plate Co., were among the traveling representatives in Philadelphia, Pa., last week.

E. A. Cowan, Boston, Mass., started last week on a ten weeks' trip south and west, and will make the Gulf States and Texas his objective points.

Mr. Armstrong, formerly representing the Union Braiding Co., Sandwich, Mass., has started in business under the name of the Armstrong Braiding Co.

P. H. Ackerman has severed his connection with William Fenton, of Boston, Mass., and will hereafter be road salesman for the Woodman-Cook Co., Portland, Me., with headquarters at the Boston office, 463 Washington St.

Among travelers met in Chicago last week were the representatives of Coettermans-Henrichs-Keck Diamond Cutting Co.; John Lunn, Snow & Westcott; Mr. Gallagher, Sinnock & Sherrill; Mr. Brooks, Brooks & Pike; F. W. Bliss, Link, Angell & Weiss; A. Kingsland, Reeves & Sillocks.

Among the Attleboro representatives who are visiting the western trade are the following: J. Cobb, Daggett & Clap; John Lamb, T. I. Smith & Co.; J. A. Lucas, A. H. Bliss & Co.; F. L. Carpenter, F. M. Whiting Co.; S. W. Abbey, E. Ira Richards & Co.; Mr. Carpenter, R. F. Simmons & Co.

The travelers in Kansas City, Mo., last week were: Mr. Brooks, Brooks & Pike; T. L. Carrow, Mandeville, Carrow & Crane; Jas. McPhail, Sussfeld, Lorsch & Co.; W. S. Strauss, Jacob Strauss & Sons; I. W. Friedman; Jno. W. Case, for H. F. Carpenter; Henry Somborn, Albert Berger & Co.

H. E. Vincent, Simpson, Hall, Miller & Co., Chicago, has returned from a southern trip. "Crops are looking fine," said he, "and also fruits of all kinds, and dealers are all looking forward to a very satisfactory trade. My business averaged up to that of last year, and I found more confidence in trade circles throughout the south.

Traveling men calling on Davenport, Ia., jewelers the past week were: L. G. Nuelsen, Wm. L. Gilbert Clock Co.; H. Klass, Glikauf & Newhouse; Otto Sinaner, Oppenheimer Bros. & Veith; F. R. Horton, Carter, Hastings & Howe; Rudolph Noel, Albert Lorsch & Co.; M. Kinna, Elgin National Watch Co.; Ned Lichenstein, Leopold Weil & Co.

Traveling men in New Haven Conn., last week were: Henry Hyman, Hyman & Kramer;

Mr. Bassett, J. W. Bassett & Co.; Mr. Deitsch, Deitsch Brothers; Mr. Frank, Goldsmith & Frank; Mr. Goldsmith, Leopold Weil & Co.; Mr. Bleecker, Bassett Jewelry Co.; Mr. Stites, Aikin, Lambert & Co.; Mr. Van Ness, Reeves & Sillocks; Mr. Dillingham, N. H. White & Co.

Traveling men in Indianapolis, Ind., last week included: E. Aubry, Vincennes Novelty Mfg. Co.; W. P. Hanford, Roseman & Levy; J. M. Beckwith, Jos. H. Fink & Co.; L. E. Meyer, L. E. Meyer & Co.; F. L. Carpenter, F. M. Whiting Co.; J. P. Shimp, Dueber Watch Case Mfg. Co.; Mr. Carpenter, Alfred H. Smith & Co.; Hubert Somborn, Albert Berger & Co.; Daniel Earl, and representatives of Holmes & Edwards Silver Co., LaPierre Mfg. Co., and Natchaug Silk Co.

Providence manufacturers are sending out their travelers through the west. Among those who are out are: Mr. Fairbrother, B. K. Smith & Co.; John M. Chandler, J. M. Chandler & Co.; A. N. Dorchester, G. E. Luther & Co.; Louis E. Fay, Kirby, Mowry & Co.; Harry Osborne, Howard Sterling Co.; Fred Clarkson, Snow & Westcott; R. L. Moorhead, R. L. Moorhead & Co.; Mr. Mumford, Waite, Mathewson & Co.; J. Parker Ford, Baldwin, Ford & Co.; H. W. Van Houten, Charles Sydney Smith.

Some of the traveling representatives in Louisville, Ky., last week were: Mr. Weinzer, Julius King Optical Co.; a representative for Levy, Dreyfus & Co.; C. W. Cary, J. B. & S. M. Knowles Co.; Jas. Becker, Alvin Mfg. Co.; Harry Osborne, Howard Sterling Co.; Mr. Ware, Arthur W. Ware & Co.; W. H. Bryant, T. G. Hawkes & Co.; W. Royal Birth, Gorham Mfg. Co.; Lewis P. Cook, J. F. Fradley & Co.; Coleman E. Adler, Byron L. Strasburger & Co.; H. B. Beckett, Dennison Mfg. Co.; Leo A. Heilborn, Godding Bros. & Heilborn.

The following traveling salesman passed through Detroit, Mich., last week: F. C. Allen, for A. Wittnauer; Jule Franklin, L. Tannenbaum & Co.; Joseph S. Beatty, the S. B. Champlin Co.; John Lunn, Snow & Westcott; Robert Welch, Welch & Miller; J. E. Simonson, A. J. Hedges & Co.; A. Kingsland, Reeves & Sillocks; Charles B. Bartlett, Whiting Mfg. Co.; F. M. Bliss, Link, Angell & Weiss; Fred H. England, Lissauer & Co.; Mr. Brooks, Brooks & Pike; H. A. Bliss, Krentz & Co.; and Thomas E. Rogers, Hayes Brothers.

Among the traveling jewelers who visited Boston, Mass., the past week were: Mr. Sherrill, Sinnock & Sherrill; Mr. Cobb, Cobb, Evans & Cobb; C. H. Barney, Middletown Plate Co.; Mr. Kurtz, George W. Cheever & Co.; Mr. Somes, S. O. Bigney & Co.; Arthur Simons, Stern Bros. & Co.; Henry G. Thresher, Waite, Thresher Co.; Mr. Royce, Royce, Allen & Co.; E. L. Spencer; Mr. Rosenkranz, J. B. Haker & Co.; Ed. Gowan, Watson, Newell Co.; Mr. Untermeyer, Charles Keller & Co.; G. A. Dean; Mr. Marble, Marble, Smith & Forrester; F. I. Marcy; Herbert Barker, J. W. Reddall & Co.; W. D. Elcox, Larter, Elcox & Co.; Mr. Wood, Carter, Hastings & Howe; Mr. McAllister, Irons & Russell; Mr. Bliss, of Bliss Bros.

## News Gleanings.

The death is reported of R. Brunow, Fort Worth, Tex.

N. A. Stevens has removed his jewelry business from San Pedro, Cal.

John McElree, Spartanburg, S. C., is auctioning off his jewelry stock.

Ed. Bennett, Warsaw, Mo., has given a trust deed on real estate for \$250.

Judgment has been rendered against Fred Clark, Manson, Ia., for \$100.

Geo. M. Emery has bought out the stock of Robt. Anderson, Northwood, Ia.

J. F. Hornberger, Lawrenceburg, O., has gone out of the jewelry business.

Geo. Doos has removed his jewelry business from Perry, Okla., to Cleveland, Okla.

Aug. Winkler, Poplar Bluffs, Mo., recently sold real estate to the amount of \$1,000.

Geo. Dover, Perry, Okla., has been disposing of some of his surplus real estate lately.

The jewelry store of Noyes & Hube, Paris, Tex., has been destroyed by fire; insurance \$2,000.

E. B. Sherman will engage in the jewelry business with his brother, Claire Sherman, Libertyville, Ill.

A chattel mortgage sale of the stock of F. P. Nuse, Buffalo, N. Y., is advertised. King & Eisele are the mortgagees.

C. E. Maxson, Desuyter, N. Y., has moved his jewelry store from the York block to his newly purchased building on Cortlandt St.

Mina P. Bates has purchased the stock of jewelry formerly owned by E. C. Bates, Palmyra, N. Y., and will continue the business.

James Annin, LeRoy, N. Y., recently moved his business from the Lampson block to 18 Main St. Mr. Annin occupied the same place 43 years ago.

H. P. Phelps, who has been in the jewelry business in Tekousha, Mich., for the past fifteen years, has closed out his business and gone to St. Joe.

Spinks & Bricher, who have been in the jewelry and musical instrument business in Crockett, Tex., have dissolved, and R. C. Spinks succeeds to the business.

C. A. Carmany, Middletown, Pa., has sold out to Walter Fuernheisen, of Manheim, who will continue the business at the old location. Mr. Fuernheisen has closed his business in Manheim.

E. F. Gordon, jeweler, Southport, N. C., was on May 4th elected Mayor of that city without opposition, polling 156 out of 161 votes cast. He had been Mayor *pro tem* for two years. Southport has a population of 2,700, and is the seat of Brunswick county.

About a fortnight ago, in broad daylight, the jewelry store of Busby & Co., Chattanooga, Tenn., was entered and robbed of eight cheap watches. This was at the noon hour, when the proprietor was at dinner. The thieves effected an entrance through a window in the rear of the house.

S. A. Newman, Chicago, Ill., has given a chattel mortgage for \$350.

The store of Donaldson & Co., Des Moines, Ia., was attached for \$711.

A judgment of \$595 has been issued against C. C. Penfold, Buffalo, N. Y.

A realty trust deed for \$400 was given by Fred Scott *et ux*, Carthage, Miss.

Andrew Texley, late of Newman Grove, Neb., has removed to St. Edwards.

Roswell B. Gordon succeeds to the late firm of Gordon & Burgin, Boston, Mass.

Edwin L. Spencer, Richmond, Ind., has given a chattel mortgage for \$2,736.

A judgment of \$585 has been issued against W. C. Nettleton, Albuquerque, N. M.

F. M. Sproehle & Co., Chicago, Ill., are succeeded by the Rogers-Williams Mfg. Co.

The stock of W. C. Booth, Belleville, Ont., was recently seized by a chattel mortgage.

Judgments aggregating \$2,439 and \$150 have been issued against L. N. Waters, Buffalo, N. Y.

Kinch & Van Duzer, Ithaca, Mich., have dissolved partnership, Ernest R. Van Duzer succeeding.

E. L. Nash, Lunenburg, Nova Scotia, is offering a compromise at 25 cents in 6, 12 and 18 months.

F. H. Main, Iowa City, Ia., has left for Chicago on business connected with the International Mfg. Co.

George Munch, jeweler, Anderson, Ind., is under arrest for the theft of watches placed in his possession to be mended.

C. A. Wismer, London, Ont., who has been conducting a combined drug and jewelry store, has disposed of the drug business.

J. C. Johnson, jeweler, Asbury Park, N. J., having rented his Ocean Grove property, has taken rooms in the Le Maistre block, Emory St. and Cookman Ave.

Fire broke out recently in the jewelry store of S. P. Stern, McKeesport, Pa., and before it was extinguished several show cases were destroyed and much jewelry damaged.

The jewelers of Muncie, Ind., have decided to close their places of business at 6 o'clock each evening during the week, except on Mondays and Saturdays, after May 5th.

W. B. Delbridge has opened a jewelry business in Jasper, Ala., on a small scale. He occupies the store room on the corner near the Bowdry Hotel and has a good field.

W. J. Rowe, Marion, Ind., has consolidated his two stores, as he was not able to give both his personal supervision. This leaves open the oldest jewelers' stand in that city. It is said that a better opening in a growing city could hardly be found.

J. T. Mace, who went to Fayette, Ala., some months ago from Vernon, Ala., has been successful in his new field. Commencing on a small scale he has advanced slowly but surely and has just recently occupied a pretty little office on Main St., where he is convenient to both local and transient patronage.

O. W. Andrae, an engraver and traveling jeweler, employed by A. L. Delkin & Co., Atlanta, Ga., was arrested last week on a charge of larceny. It is claimed by the firm in whose employ Andrae was at the time of his arrest, that he stole goods from them and sent the goods away. Andrae denied the charges. He was in the jewelry business in San Antonio, Tex., some years ago.

Morris Lewis, jeweler, 333 Chartres St., New Orleans, La., last week filed a petition in the Civil District Court, praying for an extension of time, in order that he may have an opportunity to meet pending obligations. He stipulated the time in which he can pay his obligations as 10, 17 and 24 months, and gave his assets at \$4,012.19; liabilities, \$1,971.21. A meeting of his creditors is called for June 9, at 11 o'clock, before T. Buisson, notary public.

J. M. Faeherman, manager for Willson, Eyres & Co., dealers in jewelry and bicycles, Houston, Tex., was arrested last week, charged with embezzlement, the charge being made by W. W. Willson. It seems that Faeherman left the city some days ago with a lot of goods to be disposed of at the surrounding towns. He returned, but failed to bring back part of the stock which had not been accounted for by sale. It developed that he had shipped the goods to St. Louis, as the bills of lading were found when he was searched. He acknowledged that he had shipped the goods, but said that he owned stock in the corporation of Willson, Eyres & Co., and that the goods are not worth any more than the value of his stock. When searched \$180 in cash and several diamonds were found on his person.

### Pittsburgh.

Samuel A. Till has taken quarters in the Vernon building.

Webb C. Ball, Cleveland, O., was a visitor in the city last week.

James Keller, for G. B. Barrett & Co., is in town for a few days, and reports a steady western trade.

S. L. Eshelman, lately with J. H. Lynch, Greenville, has started in business for himself in the same town.

A brand new green coat of paint and a long distance telephone are the latest improvements in E. P. Roberts & Sons' store.

Visiting jewelers in the city last week were: George B. Brady, Washington, Pa.; Frank Worrell, Washington, Pa.; B. Neville, Dawson, Pa.; T. E. S. Griffin, Elizabeth, Pa.; P. J. Manson, Jeannette, Pa.

The Cohen robbery still remains the topic of comment among the jewelers here and is as much a mystery to everyone and the police as ever. The latter complain that the robbery occurred early in April and was not reported to them until last week.

Travelers in Pittsburgh, last week included: D. Skutch, Waterbury Clock Co.; Mr. Tinker, for W. B. Durgin; N. J. Ashton, Kent & Stanley Co. Ltd.; Thomas E. Rogers, Hayes Bros.; G. D. Munson, Wm. Rogers Mfg. Co.; A. W. Atwater, Joseph Fahys & Co.; A. J. Sherrard, Enos Richardson & Co.; Mr. Gallagher, Sinnock & Sherrill.

### Cincinnati.

Eichelberger & Co. are making the medals for the mid-summer cycle races for this year.

Joseph Noterman & Co. are sending out a neat pamphlet of class pins and school medals.

The H. Keck Mfg. Co. secured the order for the diamond prizes that the Chester Park Athletic Association will give this month at the races. The prizes are four diamond studs and two very handsome rings.

A petition is being circulated from the Cincinnati Wholesale Jewelers' Association for early closing to begin May 16 and continue during the Summer on every Saturday at 12 o'clock. The committee have quite a number of signatures.

Adolph Muehlmann is working on a book for engravers which he hopes to have out by this Fall. It will contain some very valuable hints to the craft and will be useful to every practical worker. Mr. Muehlmann is an expert and has achieved considerable knowledge from experiments during the past three or four years.

Frank Duhme, J. Lakum and others of the party who went to Mexico have returned. They have started the work on some of the veins found on their ranch and expect to realize in the near future. They brought home specimens of the ore found. The copper smelting works are the most promising, while there are traces of silver, gold and lead in quantities.

The Cincinnati Wholesale Jewelers' Association held their regular meeting last Tuesday, with a full attendance. It was one of the most interesting meetings they have had this year. Everyone seemed to be alive to the interests of the association and their endeavors were combined to improve the methods of the trade and retard the evils that are creeping in. The committee on investigation of certain evils, as reported in last issue, made a very full report. Their suggestions were indorsed by the association and will be carried out. The subject of their annual outing came up and was discussed. It will be planned early this year and the committee will have plenty of time to make proper arrangements. They want to interest all the trade.

Frank Herschede has commenced the remodeling of his new quarters on 4th St. The salesroom is 31 x 90 feet, and the floor is to be inlaid with marble mosaic. It will be lighted with 250 incandescent lamps, the upright cases being bordered with them. Beginning at the entrance a horse shoe case 10 feet wide and extending back 40 feet in the center of the room will be devoted entirely to jewelry. At the back of the room about 30 feet space will be devoted to the art room and the basement 31x60 will be exclusively given over to hall clocks. The entrance will be the handsomest in town. The front entrance has two solid bronze pilasters, 8½ feet high. The vestibule is to be in Italian Renaissance style, and will show the firm's trade mark, a crown and hammer. A 10 foot window extends along the side of the alley around to the front entrance. Mr. Herschede expects to have the store completed by June.

## Special Notices.

Rates 75c. per insertion for notices not exceeding 3 lines (25 words); additional words 2 cents each. If answers are to be forwarded, postage stamps must be enclosed. Two insertions, 15 per cent. off; three insertions, 20 per cent. off; four insertions or more, 25 per cent. off. Payable strictly in advance. Display cards on this page will be charged at \$2.00 per inch for first insertion, subject to same discount as above for subsequent insertions.

Under the heading of **Situations Wanted** on this page advertisements will be inserted for **One Cent a Word** each insertion, no discount. This offer refers to **Situations Wanted only**. Payable strictly in advance. If answers are to be forwarded, postage must be enclosed.

## Situations Wanted.

Notices under this heading **ONLY** are charged at one cent a word, payable strictly in advance. If answer are to be forwarded, postage must be enclosed.

**WATCH AND CLOCKMAKER** wants position; reliable and industrious; good references. Address B. M. M., 64 Fourth Ave., Brooklyn.

**WANTED.**—Situation as watchmaker, or to take charge of a business; am in business at present; can give best of references. Address M., care **JEWELERS' CIRCULAR**.

**OPEN FOR AN ENGAGEMENT**, by a first-class watch repairer and good engraver, capable of taking charge of store; own tools, highest of reference. Address X Ray, care **JEWELERS' CIRCULAR**.

## Help Wanted.

**WANTED.**—A thoroughly first-class watchmaker good address, sober and industrious. Best references required; single man preferred; state salary. F. R., care **JEWELERS' CIRCULAR**.

## Business Opportunities.

**FROM \$100 to \$2,000** worth of city lots in the city of Newton, Kan., middle division and terminal on the A. T. and S. Fe R. R.; wish to exchange for plated jewelry, watches, clocks or wall paper. Write for particulars to John Reese, Newton, Kan.

**\$1,200** will buy my 6800 lb. steel-lined safe, plate glass store fixtures and balance of my clocks and silverware; will sell watches and jewelry if wanted; best opening in Oklahoma for a live jeweler. Chas. E. Rose, El Reno, Oklahoma.

**FOR SALE** in Philadelphia, a desirable business in a fine locality; clean stock about \$8,000, which can be reduced if desired; walnut fixtures, fine regulator, safes, etc.; good run of work; established 12 years. Address O. E., care **JEWELERS' CIRCULAR**.

**FOR SALE**, on account of death of owner, an old established jewelry store, in city of 10,000 inhabitants; good clean stock and fixtures; inventory about \$9,000; great chance for the right man; terms reasonable. L. T. Tingler, Atty., Rockville, Conn.

**SPLENDID CHANCE** for young man with small capital, in live town in Southside, Virginia; market place for six counties; five large tobacco warehouses; store excellently located; rent low; safe and other fixtures included. Address Mrs. Otto Salzman, Danville, Va.

**\$650.00 SPOT CASH** buys fixtures, material and optical goods of leading jewelry and optical store; established 15 years; western New York; bench work \$1,500 per year; only optician; will sell any other part of stock if desired. Address J. O., care **JEWELERS' CIRCULAR**.

## To Let.

**FINE OFFICE** in Decker building to sublet. Inquire at once, Room 75. Liberal concession made. 33 Union Square, N. Y.

**TO LET.**—Two upper floors suitable for diamond cutting and polishing, or jewelry manufacturing. North Light. H. Ruhnstruck, 28 Maiden Lane, corner Nassau St., N. Y.

**TO LET**—A good office on the third floor in the Diamond Exchange Building, 14 Maiden Lane, N. Y.; now occupied by the Fletcher Watch and Jewelry Co. This office will be rented very low to May 1, 1897. Apply to Janitor, or Smith & North, 14 Maiden Lane, N. Y.

## For Sale.

**FOR SALE.**—A Marvin fire-proof safe; outside width 54 inches, height 65 inches, depth 28 inches. R. A. Loveland, 177 Broadway, N. Y.

**CHEAP.**—Five burglar and fire-proof safes; handsome solid black walnut glazed office partitions, tables and other fixtures; also complete set of jewelry trunks. Max Freund & Co., 8 Maiden Lane, N. Y.

## Miscellaneous

**WANTED.**—Watchmaker to take window in office of manufacturing jeweler on Nassau St., N. Y.; cheap rent good light, good location. E. R., care **JEWELERS' CIRCULAR**.

## FOR RENT.

Large Office, 5th Floor - - **Corbin Building.**

Will let very low for Three Years.

APPLY, - - - -

**JOSEPH FAHYS & CO.,**  
NO. 54 MAIDEN LANE, N. Y.

## TO LET

—AT—

21 Maiden Lane, (HAYS BUILD'G),

## Three Fine Offices.

—INQUIRE AT—

**BRUHL BROS. & CO.,** at Above Address.

## Annual Report of the Director of the Geneva Observatory.

The report of Prof. Raoul Gautier, director of the Observatory at Geneva, on the annual competitive trial of watches for the year 1895 has been received at **THE CIRCULAR** office. There were less chronometers presented than usual, but the results, says the eminent professor, have never before been so excellent in regard to the quality of the timepieces exhibited. The report shows that in the general *concourse* of single timepieces, two out of 138 watches obtained more than 240 points, reaching as high as 247.1 and 243.1 against 242.8, the highest number of points reached in 1894. Thirteen other timepieces or 9.5 per cent. obtained more than 230 points, 43 timepieces or 31 per cent. reached over 200 points while 73 timepieces or 53 per cent. were above 180 points.

The two watches which were awarded first prize were chronometer No. 1,053 of U. Montandon-Robert with 247.1 points and chronometer No. 21,058 of A. Golay-Leresche & Fils with 243.1 points. The firms whose pieces stood next in order received second prizes. The four watches were offered by Patek, Philippe & Cie., 239.8; Vacheron & Constantin, 238.7; Patek, Philippe & Co., 238.4, and A. Golay-Leresche & Fils, 237.2. The names of these firms are also to be found several times in the lists of third and fourth prizes.

In the competitive trial between manufacturers of series of five movements each, the two Geneva firms best known in America, namely, Patek, Philippe & Co. and Vacheron & Constantin, stood at the top, the former with an average of 230.14, and the latter with an average of 229.50. These two firms, says the report, obtained results which had never been reached in any previous competition. They were awarded first prizes, as were also A. Golay-Leresche & Fils, whose watches averaged 227.14 points, and Alex. Favre, who obtained 225.38 points.

## SCRIPT MONOGRAMS

Every jeweler in America should buy a copy. Illustrates and instructs how to form 2,000 script combinations. You can secure a combination in 3 minutes that you could no design in 3 hours.

ADD. WISCONSIN BUSINESS UNIVERSITY, LA CROSSE, WIS.

PRICE 25C

## DON'T FORGET THE JEWELERS' CIRCULAR PUBLISHING CO.'S BOOK LIST

when in want of any technical book in the JEWELRY OR KINDRED TRADES. APPLY ON PREMISES:

THE FIRE WATER TAKES ITS WAY

# WESTERN SUPPLEMENT of THE JEWELERS' CIRCULAR

**Chicago Office: Room 517, Inter-Ocean Building.**

VOL. XXXII.

CHICAGO, WEDNESDAY, MAY 13, 1896.

NO. 15.

### Chicago Notes.

Mr. Harmon, Forbes Silver Co., Meriden, is visiting here.

Mr. Sparrow, representing Stern Bros. & Co., is on his annual fishing trip to Mercer, Wis.

George B. Kelley, of the Rockford Silver Plate Co., is enthusiastic over his Summer resort, the "Avery Beach Resort" at South Haven, Mich., which opens June 10th.

The salesmen for the Towle Mfg. Co. on the road are meeting with better business than any time previously this year. The company state that business generally is improving.

Clapp & Cowl dissolved partnership May 1st, Mr. Clapp retaining a very small interest in the house, and the firm name remaining unchanged. Mr. Cowl remains in active charge of the business.

McKee & Zimmerman, opticians, dissolved by mutual consent May 1, Mr. McKee buying the Zimmerman interest. C. W. McKee will continue the business as usual at the old location, 65-67 Washington St.

J. Milhening has installed a 5-horse power motor in his new shop, northeast corner of State and Adams Sts., and will hereafter use electric power. The new shop is larger than his former one, with accommodations for 45 workmen, and is much better lighted.

C. F. Gillmann, "the north side Tiffany," has moved from 124 N. Clark St. to 145 N. Clark St. For two years Mr. Gillmann has been crowded for room, and in the new location will have ample room to display his stock, as well as scope for his well known ability as a window dresser.

Everyone misses the large Lapp & Flershem street clock that for years was a landmark on upper State St. The timepiece has been removed to the northeast corner State and Adams Sts., where by an ingenious arrangement its three dials look from the second story up and down both streets.

Manager Sercomb, returned from the far northwest, is enthusiastic over the prospects for that district. Montana cattlemen feel better than for years and mines are being worked to a greater extent than ever with a probable output double that of 1895. Everything in that section looks favorable for Fall trade.

J. R. Schneider, Evanston, Ill., a frequent caller here, has gone to Burlington, Wis. A

good luck story is told of Mr. Schneider. He wanted to cancel his insurance and take out new policies at Burlington, but was prevailed upon to simply transfer it, leaving it in force during removal. After the goods were packed a fire destroyed part of the stock, which was promptly paid for by the insurance company.

One entering the new salesrooms of Lapp & Flershem, northeast corner State and Adams Sts., will be at once struck by the noticeable improvement of arrangement over their former store and the much better light afforded for the examination of wares. The quarters have a south and west exposure with almost continuous windows on both sides. At the right of the entrance are the spacious offices, and from here for a half block west stretches a sea of showcases bathed in a flood of light. Along the north and west sides extends a gallery 12 feet wide used for stock purposes. The entire west side is devoted to the material department, a feature of the house that is most complete. A long line of display wall cases for silver ware partitions off the shipping department. The arrangements for facilitating business are specially good, and the claim of the firm to having the finest wholesale salesroom in the west cannot well be refuted.

### Louisville.

H. C. Korfhage, after an illness of three months, is able to attend to business again.

George Wolf & Co. had a big run on school medals last week. They had a number of orders from Canada and Texas.

W. C. Kendrick, of Wm. Kendrick's Sons, is in Nashville, Tenn., attending a book committee of the Methodist Church South.

The most popular fad are the dumb-bell cuff buttons and stone set blouse buttons, the inch belts and the silk suspenders with gold buckles containing miniatures.

An attempt was made last week to start the early closing of the stores among the retail jewelers. One jeweler objected, but it is thought that he will finally concede to the arrangement.

James K. Lemon & Son are now established in their new store, and will have an opening this week. They have added an art room which is divided from the store proper by a handsome mirrored partition.

Mr. Brandenburg the Jefferson St. jeweler who sold out to E. C. Delaw last week and

was afterwards forced to take his stock back on account of indebtedness for rent, will be sold out May 14, by the sheriff. His store is now closed. Mr. Godshaw will travel again for the Lorch Jewelry Co.

### Detroit.

Mr. Phillpot, with Roehm & Son, last week returned from a visit to friends in England.

James Flemming, for years one of the pioneer jewelers of Nashville, Mich., has again opened a store there after a two years' retirement.

Announcement has been made of the wedding of Charles Bell, in June. He is manager of E. T. & W. B. Webb's jewelry store, Jackson, Mich.

The following Michigan country jewelers were in Detroit last week: F. J. Barlow, Williamston; Fred Grimm, Mt. Clemens, and W. W. Burgess, Marine City.

E. H. Pudrith, representing Eugene Deimel, started out this week for a visit to the Michigan trade. George L. Low, with H. Koester & Co., has returned from a trip through the Thumb.

Last week Unger Bros., New York, began suit in the Wayne Circuit Court against F. G. Smith, Jr., for \$500, assumpsit. It is understood that several more suits will be commenced shortly, backed by John Baumont, of this city. F. G. Smith was a member of F. G. Smith, Sons & Co., F. G. Smith & Sons, and Smith, Sturgeon & Co., jewelers. The first firm failed, the last named being their successors. Recently the Smiths retired from active participation in the business and are now engaged in the insurance line. A number of accounts were left unpaid and the plan now is to get a judgment and levy on their present interest in Smith, Sturgeon & Co., which consists of stock.

In a fire in Forest City, Pa., the jewelry store of W. H. Wildenberger was damaged.

A negro broke into B. H. Hill's store, Ladonia, Tex., recently, and stole \$1,200 worth of jewelry. He confessed to the robbery, giving his name as Carl Walker.

E. B. Steele, lately with McAllister & Humburch Bros., Rochester, N. Y., has bought out the jewelry store of E. M. Cox & Son, of Phelps, N. Y., taking possession of same May 5th.

**Pacific Coast Notes.**

Hiram D. Lewis, Ogden, Utah, died recently.

A. W. Hagstrom has started a plating establishment in Chino, Cal.

C. Hadenfeldt, of Rothchild & Hadenfeldt, San Francisco, is selling the assigned stock of Harry Frutig, Gilroy, Cal., at auction.

William Keller and Mr. Praet have purchased the fixtures of the jewelry store of A. E. Bocks, Woodland, Cal., and have opened with a new stock.

H. A. C. McPhail, Santa Barbara, Cal., recently interrupted a robber in the act of removing several packages of jewelry from his store. A man named Douglas was arrested the following day for the attempted burglary.

**Minneapolis and St. Paul.**

H. E. Tinker, Waseca, Minn., has removed from Redlands, Minn.

W. E. Colley, Broadhead, Wis., is reported out of business there.

G. Hallauer, Minneapolis, who two months ago left for his old home in Switzerland, returned last week.

T. J. Ellingboe, Minneapolis, has retired from business, owing to ill health, and offers his entire lot of fixtures, tools and machinery for sale.

Larson & Peterson, St. James, Minn., have sold out to C. A. Westerbaum, formerly in

business in Rochester, Minn. Mr. Larson and Peterson have gone to Elgin, Ill., to work in the Elgin Watch factory.

C. W. Lowry & Co., Windom, Minn., recently sold out to A. B. Cone, who will continue business at the old stand. C. W. Lowry has gone to Georgia for his health, and intends to establish himself in business there.

Eastern jobbers and manufacturers represented in the Twin Cities the past week were: Meriden Britannia Co., by W. C. Wall; G. H. Fuller & Son, by Mr. Lamb; Sussfeld, Lorsch & Co., by C. O. Hartung; Hammel, Riglander & Co., by Mr. Schneider.

A. E. Hall, for many years traveling salesman for the Holmes & Edwards Silver Co. and the Manhattan Silver Plate Co., has rented a salesroom at No. 410 Lumber Exchange building, Minneapolis and is now northwestern agent for these two companies.

The I. B. Miller Jewelry Co., Minneapolis, recently purchased the bankrupt stock of the Lacs estate, Minneapolis. The company have rented a store at 237 Nicollet Ave., and will open for business about May 15th under a separate name, the Minnesota Jewelry Co.

The new clock for the tower at the Minneapolis court house has reached that city, and is at the depot awaiting transportation to the court house, where it will be put in place as soon as the arrangements are perfected for doing so. W. S. Johnson, president of the electric company at Milwaukee which bears his name, is in

the city, together with William Ghers, superintendent of the plant. G. A. Sweet, Minneapolis manager of the company, is all ready to have the clock put in place. He has had the care of the other court house clocks, which are all to be run in connection with the motor in the basement to operate all the clocks, including that on the tower. As soon as the clock is put in place and regulated, it will be connected with the bells and the hours will be struck automatically. The chimes are the largest of their kind in this country. The clock-dial is larger in diameter than the Westminster clock in England.

**Indianapolis.**

Newcomer & Doering, Nappanee, Ind., have dissolved partnership, Mr. Newcomer continuing the business.

May 1st Horace A. Comstock's store, 16 E. Washington St., was burglarized, about \$25 worth of rings being carried off. The thieves crawled through the transom over the front door.

J. C. Walk & Son brought suit May 1st against Sarah H. Wilson to collect \$125 which, it is alleged, is due from the defendant for repairs on a watch that had been injured in a railroad wreck.

State jewelers in the city last week included: L. C. Phillips, Carbon; Louis F. Ott, Veedersburg; A. Meissen, Cicero; E. M. Wilhite, Danville; J. M. Hudson, Fortville; T. J. Johnson, Shoals; and E. O. Collins, Franklin.



No. 1004 and 1008. Closed.

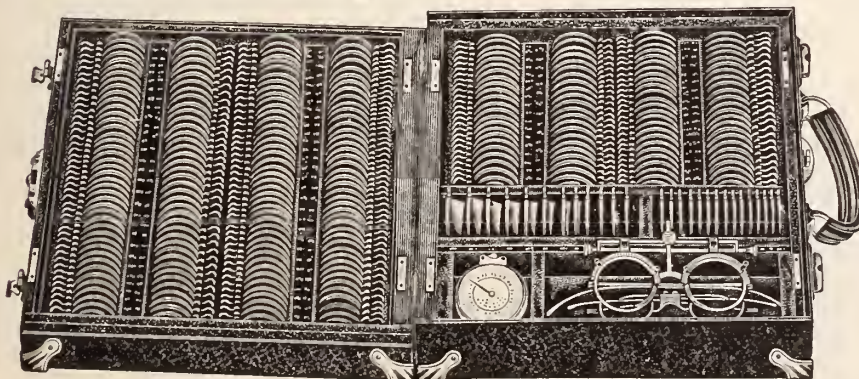

NEW STYLE FOLDING TRIAL CASES. No. 1004 and 1008. Open.

SEND FOR CATALOGUE AND MENTION JEWELERS' CIRCULAR.

“ALWAYS AHEAD”  
OTHERS FOLLOW.

**Geneva Optical Company,**

67-69 WASHINGTON ST., CHICAGO.

**New Catalogue Now Ready.**

**NEW PRICES  
NEW INSTRUMENTS**

For Oculists and Opticians.

Prescription Work to Order,  
Promptly and Accurately.

# THE PERFECTION SHOW CASE

FOR FINE JEWELRY TRADE.

WE CHALLENGE THE WORLD TO  
PRODUCE ITS EQUAL.



IF YOU ARE INTERESTED IN SHOW CASES AND  
JEWELRY FURNITURE, WRITE US FOR  
FULL INFORMATION.

## A. H. REVELL & CO.,

431 to 437 Fifth Avenue, Chicago.

**ONE**

Agent wanted in every town  
to sell the

**STRICTLY HIGH GRADE**



**\$100.00 BICYCLES**

Write for Catalogue and Agents'  
Terms.

Send 10 Cents for Elgin King  
Scarf Pin.

Address Department B,  
**ELGIN CYCLE CO.,**  
ELGIN, ILL.

**PARSONS & SCHOOL**  
—FOR—  
**WATCHMAKERS,**  
PEORIA, ILL.  
Send for Circular and Terms.  
**PARSONS & CO.**

A new plating shop has been established in Muncie, Ind., by Keiser Bros.

E. C. Miller has engaged passage for himself and family on the *Lahn* to Southampton, June 9th.

F. M. Herron has displayed in his window the two handsome gold medals presented to Gen. Benj. Harrison while he was President. The medals have been lying in the Treasury vaults in Washington, but in compliance with the concurrent resolution recently passed by Congress, were sent to the ex-President. The medals were described in a recent issue of THE CIRCULAR.

### Cleveland.

George K. Foltz, Akron, formerly located in Cleveland, was in the city last week.

C. F. Gilbert has removed from 1359 Lexington Ave. to a much larger and better located room a few doors east of Willson St. on Euclid Ave.

Julius King, of the Julius King Optical Co., has removed to New York, where the main office of the company is situated. The Cleveland office will be maintained, however, under the management of Grant Whittlesay.

### St. Louis.

Last advices from A. S. Mermod were that he was in Berlin.

M. Dorenfield, Corsicana, Tex., is in town, and expects to be here for a week.

Mr. Kingsbury, the missionary in these parts of the Elgin National Watch Co., is in town.

A. R. Brooks contemplates going into the optical line on a large scale, in the near future.

E. Jaccard Jewelry Co. report a great run on blouse sets, 800 of them having been sold the past week.

The next meeting of the board of directors of the Missouri Retail Jewelers' Association will take place May 13.

The stock of J. A. Droz, who failed recently, is being sold by the continuous auction plan. There does not seem to be much of it left.

E. Jaccard Jewelry Co. have a number of incandescent electric lights arranged in their Olive St. windows, that show up very attractively every evening. The darkened store adds to their effectiveness.

EST. 1870. **DR. PETER HENRY,**  
SPECIALIST IN  
**Watch Case Diseases**



Key Winders  
changed to  
Stem Winders

Hunting Case  
changed to O.s

English Case  
changed to fit  
American  
movements

Can be cured at  
**53**  
**LONGWORTH ST.,**  
Cincinnati, Ohio.

The auditorium for the National Republican Convention is nearing completion, and the Mermod & Jaccard Jewelry Co. have gotten out a beautiful souvenir spoon with a picture of the building in the bowl of it. They are also abreast of the times by having a companion spoon to this, with William McKinley's picture emblazoned on it.

There is a store on Olive St. opened last week. It is down town, and the rent must foot up a handsome figure. The stock in trade consists of a large quantity of stones called "topaz diamonds" which retail at \$1.00 a piece. Nothing else is carried in stock and the quarters are far more pretentious than many a jeweler occupies.

Among eastern representatives here the past week may be mentioned: Mr. Horton, Carter, Hastings & Howe; Mr. Metcalf, R. Blackinton & Co.; Frank Carpenter, Alfred H. Smith & Co.; Louis Fay, Kirby, Mowry & Co.; C. F. Ketcham, Riker Bros.; Silas Pickering, Shoemaker, Pickering & Co.; Harry Rolfe, Wilcox Silver Plate Co.; J. H. Friedlander, H. Z. & H. Oppenheimer.

Many jewelers now carry plain leather belts in stock. A good explanation was given THE CIRCULAR correspondent for this. His informant said: "I had as many as 30 or 40 calls some days for belts costing 50 cents or thereabouts. Now, I couldn't sell them at this price and have silver buckles on them, so I concluded to submit to the inevitable and carry what was called for."

### Kansas City.

Jesse Frenkel has gone on the road for H. Oppenheimer & Co.

Victor Kohen, with H. Oppenheimer, has gone to New York for a short visit on business and pleasure.

The store of J. R. Gleason, formerly of this city, but now of Cripple Creek, Col., was entirely burned out a few days ago in the large fire in that town. His stock and fixtures were a total loss. Mr. Gleason suffered a severe loss in the death of his daughter two days after the fire, she having caught a severe cold at that time.

Among out-of-town buyers here last week were: W. S. Beasley, Rich Hill, Mo.; M. McNault, Bronson, Kan.; E. L. Sloan, Wamego, Kan.; Wm. Rushmer, Pueblo, Col.; R. H. Morehouse, Council Lake, Kan.; Hal H. Essey, Plattsburg, Mo.; Chas. Gleason, St. Joseph, Mo.; J. P. Kelley, Marshall, Mo.; E. C. Timeman, Huntsville, Mo.; B. Hoffman, Leavenworth, Kan.; C. H. Hessen, La Cygne, Kan.

A. H. Porterfield, Holyoke, Mass., is making a compromise offer to his creditors.

T. J. Freistadter, Harrisburg, Pa., has removed from 165 S. Front St. to 271 S. 2d St.

Charles L. Dingler, jeweler, located on the west side of Edgmont Ave., Chester, Pa., will shortly move to 815 Edgmont Ave. The store will be overhauled.



**Queries by Circular Readers.**

**NOTE.**—Questions under this department will be answered as promptly as possible. Some queries require careful investigation before a satisfactory answer can be given; hence such answers are often seemingly delayed. THE CIRCULAR desires every jeweler to take advantage of this department.

PORTLAND, OTC., April 15, 1886.

Editor of THE JEWELERS' CIRCULAR:

I have a customer who has a watch, the movement of which we think is one of the first "Walthams" that were made. It is an hunting, 11jeweled, gilt, key winder and has a steel balance. It has stamped on it, "Dennison, Howard & Davis," and the number is 3,436. My customer would like to know about what year it was made. Can you give us the desired information? Yours,  
THE G. HEITKEMPER CO.

Per G. Heitkemper.

ANSWER:—The movement was finished during 1856 or before March, 1857.

PROVIDENCE, R. I., April 28th, 1896.

Editor of THE JEWELERS' CIRCULAR:

Will you please inform us what will take fire out of silver, and oblige yours very respectfully.

FLINT, BLOOD & Co.

ANSWER:—The term "fire" as applied above is ambiguous to us. We presume that the correspondent means that the copper alloy has burnt or oxidized. In this case the only remedy is to refine the silver again and use new copper for alloying.

HARRIMAN, Tenn., April 18, 1896

Editor of THE JEWELERS' CIRCULAR:

I am frequently called upon to remove scratches from large sets in pins; can you tell me a neat way to do it?

ANSWER:—The process of taking out scratches from large sets in pins is a branch of lapidary work, which is impossible for one not a lapidist to perform. The scratches must be polished out. We would advise you to send such work to professional lapidists, as M. Fox & Co., 1 Maiden Lane, and Graham & Co., 63 Nassau St., New York.

SAN LUIS POTOSI, Mexico, April 5.

Editor of THE JEWELERS' CIRCULAR:

Will you please refer me to some house that handles old stamps and old coins, or tell them if you are acquainted, to send me a catalogue of prices. THE CIRCULAR comes regularly, and would hardly know how to run the shop without it. The Work Shop Notes are worth the subscription price. D. B. SPENCER.

ANSWER:—The following firms deal in old stamps and old coins: J. W. Scott Co., 40 John St.; Scott Stamp & Coin Co., 18 E. 23d St.; Bogart & Durbin Co., Tribune buildi g; Wm. P. Brown, 301 Broadway; G. B. Callman, 299 Pearl St.; Hy. Grimmel, 85 Nassau St.; E. T. Parker, 30 E. 23d St., all of New York. These firms issue price-lists, which may be obtained from each for a nominal sum, from 25 cts. to \$1.00.

LOST HIS HEART.

CRIMSONBEAK—"What's the matter with young Huggins?"

YEAH—"I understand he has lost his heart."

"Is that all. He makes as much fuss as if it was his collar button."—Yonkers Statesman.

**Artistic Silver.**

Have you seen any more truly artistic or graceful spoon patterns than our "Apollo" and "Lexington," illustrated herewith? They are made in Sterling Silver only and in a full line of all sizes, including cutlery.

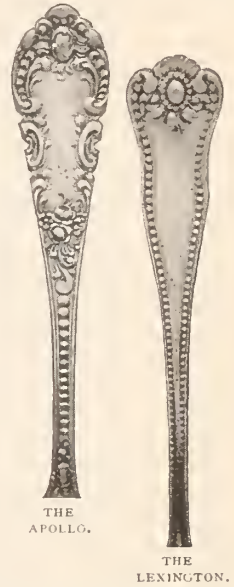

J. B. & S. M. KNOWLES CO.,

PROVIDENCE, R. I.



TRADE MARK

Seen on Silver Shows Sterling.

**SLOAN & COMPANY,**

SUCCEEDING

JOHN A. RILEY & SLOAN CO.,

**MANUFACTURING JEWELERS,**

23 MAIDEN LANE, N. Y.

HAYS BUILDING.

AUGUSTUS K. SLOAN, Pres.

BENNET OSBORN, JR., Treas.

FRANK T. SLOAN, Vice-Pres.

ALLAN A. McDONALD, Sec'y.

**AMERICAN WATCH CASE CO.,**

11 JOHN STREET, NEW YORK.

Manufacturers of **FINE SOLID GOLD CASES.**



Sold DIRECT to the RETAIL TRADE only.

**S. M. LEWIS & CO.**

**Have Removed**

To the

SILVER GOODS A SPECIALTY.

**LORSCH BUILDING,**

**37 and 39 MAIDEN LANE, NEW YORK.**

**This TRADE MARK on CUT GLASS is a GUARANTEE**



of Superior Quality, Design and Workmanship and Unsurpassed Brilliance of Cutting. Our Goods are especially desirable for the Jewelry Trade.

Send for Our New Catalogue ...

**STANDARD CUT GLASS CO.,**

545-547-549 W. 22nd STREET, NEW YORK.



**The STATIONERS' ENGRAVING CO.,**

98 TO 102 NASSAU STREET, NEW YORK.

MAKERS OF

WEDDING INVITATIONS, RECEPTION AND VISITING CARDS

of the Best Quality, which are offered to Jewelers of recognized standing only.

Trade Mark 'SILVER WHITE,' registered.

**JOHN T. PECK,**  
**WATCHMAKER**  
 —FOR THE TRADE.—  
 409 WASHINGTON ST.,  
 Room 15. BOSTON, MASS.

**FERD. FUCHS & BROS.**  
**SILVERSMITHS.**  
 MAKERS OF STERLING SILVERWARE,  
 808-810 Greenwich St., - New York

**H. M. RICH & CO.,**  
**Jewelry - Auctioneers,**  
 21 School Street,  
 BOSTON, MASS.

PHOTO-MINIATURE.  
**PORTRAITS \$1.50**  
 ON  
**WATCHES**  
 The Goldstein Engraving Co.,  
 1 MAIDEN LANE, NEW YORK, N. Y.

**O. NEWMAN,**  
 Gold and Silver Electro-Plater.  
 Etruscan Coloring a Specialty.  
 WATCH CASE POLISHING.  
 75 Nassau St., Room 8 Rear Building, New York

**SECURITY PIN GUARD**  
 PAT'D DEC. 25, 1894  
 MANFD BY SECURITY MFG CO. **25¢**  
 7 ASTOR HOUSE (BROADWAY) N.Y.  
 85c. doz. Net Cash Discount to Jobbers

**WOOD & HUGHES,**  
 STERLING SILVERWARE MANUFACTURERS  
 New York Agents for the Derby Silver Co.  
 FINE QUADRUPLE PLATED WARE,  
 No. 16 JOHN STREET, NEW YORK  
 206 Kearney St., San Francisco, Cal.  
 HASKELL & MUEGGLE, Agents

**QUICK SELLERS.....**  
 IN STERLING SILVER  
 ARE MADE BY  
**CODDING BROS. & HEILBORN.**  
 North Attleboro, Mass.



**REGINA**  
 MUSIC BOXES  
**A. WOLFF,**  
 General Agent,  
 LINCOLN BLDG., 14th  
 St. & Union Sq. W., N. Y.

**CAMPBELL-METCALF SILVER CO.**  
 SILVERSMITHS.



ALL GOODS 925/1000 FINE.  
 Factory, Providence, R. I. Offices, New York and San Francisco.

**The Latest Patents.**

ISSUE OF MAY 5, 1896.

559,422. FOUNTAIN-PEN. LEWIS E. WATER-

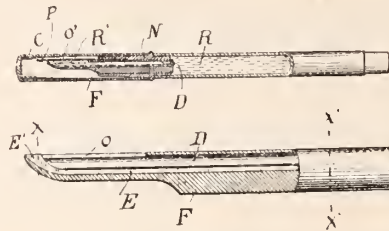

MAN, Brooklyn, N. Y. - Filed Sept. 27, 1895. Serial No. 563,842 (No Model.)

559,438. EYEGLASS-CASE. PETER CLOSS, Wollaston Heights, Mass., assignor to Andrew S. Lloyd & Co., Boston, Mass. - Filed Oct. 9, 1895. Serial No. 565,132. (No model.)

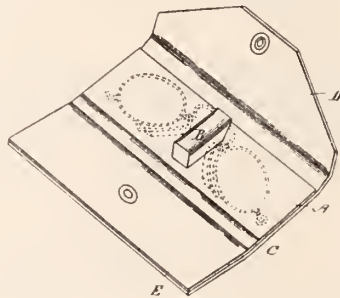

A case for eyeglasses composed of a strip A, strips or offsets flexibly connected to the sides thereof, and covering-pieces flexibly connected to the opposite sides of the said offsets, and said strip A being further provided with an eyeglass-receiver B, arranged to hold the strip A and the said covering-pieces away from each other.

559,512. STEADY-PIN FOR WATCHES. HENRY J. CAIN, Lancaster, Pa. - Filed Mar. 7, 1896. Serial No. 582,236. (No model.)

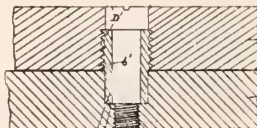

The combination, with two plates having oppositely-located screw holes of a tubular steady-pin secured in the screw hole of one of said plates and having the projecting end thereof adapted to engage the screw-hole in the other plate, and a screw passing through the steady pin and interlocking with a thread in the screw-hole engaged by the steady-pin.

559,527. FRUIT-HOLDER. FRANCIS F. HEILBORN, Plainville, Mass.; Leopold A. Heilborn administrator of said Francis F. Heilborn, deceased - Filed Jan. 23, 1894. Serial No. 497,820. (No model.)

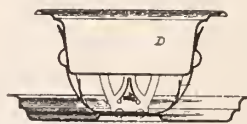

A holder for oranges comprising a cup shaped receptacle adapted to receive an orange, and a suitable base or support therefor, said receptacle being provided with means, substantially as described, projecting inwardly from the body thereof, for piercing the skin of the orange to prevent rotation thereof within the holder.

559,608. MUSIC BOX. PAUL T. A. RODECK, Union, Hudson County, N. J. - Filed Mar. 3, 1896. Serial No. 581,618 (No model.)

DESIGN 25,452. BADGE. FRED LUCKING, Philadelphia, Pa., assignor to the National Society of the Children of the American Revolution. - Filed



April 4, 1896. Serial No. 586,265. Term of patent 14 years.

DESIGN 25,453. CAMPAIGN BADGE. JOSEPH S. BLINN, New Haven, Conn., assignor to The Scovill



Mfg. Co., Waterbury, Conn. - Filed March 24, 1896. Serial No. 584,701. Term of patent 13 1/2 years.

TRADE MARK 28,226. CULINARY ARTICLES AND TABLEWARE. POPE'S ISLAND MFG. CORPORATION, New Bedford, Mass. Filed April 6, 1896.



Essential Feature. - A sperm whale in outline and the word "NON-CORROSIVE" on the body thereof. Used since February, 1896.

**Connecticut.**

Lewis S. Owens, Norwalk, has moved from 111 Washington St. to Hoyt's Theater block.

A. W. Austin's jewelry store, Norwalk, was closed May 6th for inventory. It is rumored that the stock will be sold by auction.

Business at the New Haven clock factory continues quite brisk, and the working time of nine hours a day is maintained. There is an excellent call for several of the lines of clocks made by the company.

Walter H. Bradley, the well known traveling salesman for the Bradley & Hubbard Mfg. Co., Meriden, was united in marriage May 5th to Anna H. Keating, proprietor of a cloak and ladies' furnishing goods emporium, Meriden.

A. H. Condell and E. A. Freeman are busily engaged in re-establishing the old E. N. Welch Mfg. Co., Forestville, on a new basis. Mr. Condell says that the shop will be running again before the end of Summer. The shop has been shut down for nearly three years now.

Papers in a suit in the United States Circuit Court between Jennings Bros., Bridgeport, as plaintiffs, and the Rogers Silver Plate Co., Danbury, were served Saturday last by United States Marshal R. C. Morriss. This is an action brought to obtain an injunction restraining the Rogers Silver Plate Co. from continuing to manufacture a certain mirror frame on which the complainants have a design patent. The complaint also contains a prayer for an accounting for the profits which the defendants have received from their sale of articles manufactured under this patent for the last year.

## Workshop Notes.

**Broken Jewels.**—If there are any jewels broken, remove the old one and carefully open the setting with a setting opener. Look for a jewel to fit it, one that is not too large for the pivot—better too small than too large, and if the repairer always keeps a large assortment on hand, he will quickly find one that will fit.

**Broken Screw.**—To take out a broken screw, take a good sharp graver; sometimes you can turn it out, or you can cut a slit in it with the file, and then take it out with a screw driver. If this fails, perhaps you can drill it out, but if too hard to drill you will have to use a hand punch with a heavy end and hit hard.

**Tools.**—The watch repairer should be very particular in selecting his tools; about three widths of screwdrivers, keeping them in the best of order, square across the point of the blade; he should never use a screwdriver that is either too narrow or too wide for the screw, and when using it be careful not to let it slip, for fear of marring the plates or bridge of a watch. Besides this, the handles of the screwdrivers should be of different shapes or styles, so as to save time in picking up the one wanted.

**Jewel Pin.**—If the ruby pin or jewel pin is broken, or someone has put in a piece of brass, remove it and put in a new pin. Take the balance, remove the hairspring and roller, and look for a pin. Having found one, place it in the roller and in a tool for that purpose, and place a small piece of shellac on it and then heat it over the alcohol lamp until the shellac flows; next shift the pin a few times so that the shellac gets all over; then dip it in benzine to cool. Next place the roller on a broach and clean it of the unnecessary shellac, and finally put it on the balance again.

**Oil for French Clocks.**—As a rule, clock oil should be used in clocks. If the oils are good, the difference between clock and watch oil is that the former has more body and will stay in its place under a heavy pressure where thinner oil would be squeezed out. But as there are no very heavy pressures in the ordinary French clocks, clock oil could be used on the heaviest bearing, and watch oil on the others. Or if the clock was a fine one, and was expected to run for a long time before being cleaned again, chronometer oil should be employed. But, generally speaking, first class clock oil is generally good enough for the ordinary French clock.

**Putting in a Pivot.**—To put in a pivot use a good drill the right size for the shoulder, with equal parts of carbolic acid and turpentine, as this will assist in drilling the hardest staffs. If the staff has been pivoted before and is not true, put in a new staff, for everything about the escapement must be true. Use a good centering tool; it will be necessary sometimes to drill by hand, but a lathe can be used generally. Old riding bows from spectacles make good pivots. Drill deep enough to hold well, then fit in with a square

end on the pivot and tap in the pivot stake gently. Then roll down in the pivot lathe to fit the jewel; be sure to roll it the length of the hair bow so that the pivot will be true or will file true.

**Tempering Long Pieces of Steel.**—To handle a long, thin piece of steel, such as a small French clock pinion, without getting it out of shape is a most difficult, and it may be said, a very hazardous operation, but still it may be done. The first necessity, if it is to be heated in an open fire, is to have uniform heat. It is preferable to heat the steel in a brass tube filled with charcoal. The tube must have the perforation not much larger than the object to be handled, and must be of considerable solidity, as the charcoal without a good body of metal would be a poor conductor of heat. The fluid to be used in the process of hardening should be linseed oil, cottonseed oil, or, the best of all, castor oil mixed with kerosene in proportions of about one-half the castor oil to one of kerosene. It has been observed that small steel objects spring more in hardening by being plunged into a thin, quickly cooling fluid, such as water, etc. By the use of castor oil we have a thick, slowly cooling fluid, while the admixture of kerosene oil imparts a high degree of hardness and toughness. When used, most remarkable results may be expected from this mixture, and it is well worthy of a trial. It is always of paramount importance in performing the operation of hardening a delicate spring without injury, to heat and cool all parts of the article simultaneously.

## Enriching the Surface of Silver.

BY the application of the processes about to be described the finishing touches in their relation to articles or wares of silver manufacture are effected. These processes, as adopted by the trade, are various, almost every firm having a specially prepared mixture and mode of employing it. We shall refer only to those which, from their practical utility, are likely to be of service to those workmen who have to do with this particular method. The branch of the art of which we are now treating comes only into operation when every other process of workmanship has been completed, and some of these processes must be executed in a perfect manner in order to arrive at the highest possible result in this one. The best and richest surface is produced when the metal to be operated upon is good in quality and the workmanship of a fair order, so far as regards smoothness and freedom from surplus solder marks.

My method for the coloring or whitening of silver goods is highly simple; the following are the details: A mixture of very dilute sulphuric acid is first provided in the proportion of one ounce to forty ounces of water and well mixed together; the work after being heated to a good red heat is boiled in this, which soon removes the oxide from the surface and shows the fine white color of the real silver. Objects of delicate workmanship are usually annealed by the gas; being placed on a pumice stone of

light material, the flame of the gas is blown with the mouth blow-pipe in such a manner that the object gradually becomes heated all over alike, and the work should be well heated, as this promotes the process of oxidation and subsequently that of whitening. The oxidation takes place at the expense of the copper in the silver alloy, and this is only affected by raising the articles to a very high temperature, which produces the oxidation of the copper coming in contact with the air and which necessarily exists upon the surface of the alloyed goods. Whitening silver goods, therefore, is nothing more than the removal of the base alloy from the surface, leaving the pure metal behind, with its full rich colors. Therefore, to be clear, the process of annealing in contact with cold air oxidizes the copper upon the surface and the pickling mixture so dissolves and removes it that it gradually undergoes a process of refining and is ultimately made to represent the first metal in all its purity.

Sometimes silver work is to be seen having a brown color upon it; this is produced when the acid employed for coloring has been too strong; it can only be remedied by another annealing and boiling out in a much more dilute mixture. There are other methods employed in the trade for the purpose of whitening silver work of the best quality, and annealing is always part of the process. Other ingredients, such as salt and tartar, permanganate of potash, cyanide of potassium, alum, &c., have been severally used for the cleaning or whitening mixture. They may be useful in their application to plated work articles, that have received a coating of pure metal by means of the electro-metallurgical process for cleaning purposes only, but for all practical purposes the process to which I called special attention is much to be preferred.

Common articles of silver cannot be whitened by annealing and boiling out in a diluted acid; a thin film of pure silver must be deposited upon their surface by the process of electro-deposition, or by the action of some chemical preparation in which fine silver forms the principal ingredient. Such preparation, however, as the latter, can be used only on plain surfaces; therefore they are not applicable to all kinds of work. They are composed of the following chemical ingredients: I. Chloride of silver, 1 part; cream of tartar, 1 part. II. Chloride of silver, 1 part; common salt, 1½ parts. III. Chloride of silver, 1 part; prepared chalk, 1 part; pearl-ash, 1 part. IV. Chloride of silver, 1 part; alum, 1 part; common salt, 2 parts. The chloride of silver is easily prepared by precipitating it from the vitrate with a solution of common salt or hydrochloric acid. The various mixtures should be worked up with water into a thin paste and applied to the work by rubbing with a soft cork or piece of wash-leather, or by thoroughly stirring it about in the mixture until it has acquired the requisite degree of whiteness. For the purpose of silvering watch and clock dials, &c., these mixtures may be used with advantage and entire success.

# "TRADE-MARKS OF THE JEWELRY AND KINDRED TRADES."

Copyright, 1896, by The Jewelers' Circular Publishing Co.

For seven months THE JEWELERS' CIRCULAR has had under way a work that will comprise the trade-marks of every branch of the Jewelry, Watch, Clock, Silverware, Silver Plated Ware, Optical Goods, Precious Stone, Art Pottery, Bric-à-brac, Cut Glass and cognate lines of the Jewelry Industry.

The work is now nearing completion. We consider it will be the most valuable book that has ever been issued to the Jewelry trade.

It is a work which the retailer and wholesaler will immediately appreciate.

It will be a book of constant reference, and will be consulted more perhaps than any other book issued to the trade.

It will be a book of daily use.

It will be sold at a figure that will guarantee its rapid distribution.

In addition to illustrations of the various trade-marks and the names and the addresses of the firms to whom they belong, and the class of goods to which they appertain, the work will contain other interesting and valuable information bearing upon the subject of trade-marks.

*Such a work will prove an admirable medium for advertising to the trade; we have therefore reserved a number of pages for this purpose.*

*Firms desiring to engage advertising space in this work will be furnished with further information upon application.*

Those firms who have as yet not sent electrotype, print or drawing of their trade-mark or trade-marks are requested to do so at the earliest possible moment.

THE JEWELERS' CIRCULAR PUB. CO.,  
189 BROADWAY, NEW YORK.

Members of the Trade, Manufacturers, Wholesalers and Retailers should at once place their orders for

"TRADE-MARKS OF THE JEWELRY AND KINDRED TRADES."

\$1 per copy. Bound in Cloth. Payable now or upon delivery of Book. Detach order below and forward to the Jewelers' Circular Publishing Co., 189 Broadway, New York.

ADVANCE ORDER BLANK.

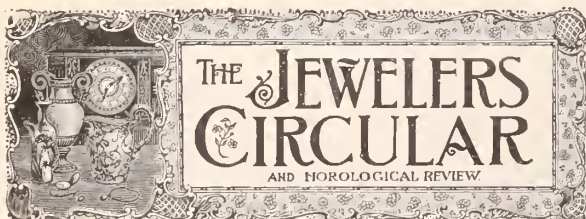

189 Broadway, New York.

1896.

Please file this order for

copy of

"Trade-Marks of the Jewelry and Kindred Trades"

for which I agree to pay \$1.00 per copy, postage prepaid, upon delivery of book.

Name .....

Street..... City..... State.....

DEPARTMENT OF  
ADVICE AND CRITICISM  
ON  
RETAIL JEWELERS' ADVERTISING.

BY ALFRED MEYER.

[This department is absolutely free to every retail jeweler and optician. Forward for criticism your newspaper ads., booklets, catalogues, novelties, circulars, etc. Ask advice and offer suggestions. Replies in these columns are unbiased. Please make letters as brief as possible. Every letter and ad. sent will receive full attention, though the publication of the matter may sometimes be delayed a week or two. Address letters and other matters to The Jewelers' Circular Pub. Co., 189 Broadway, New York.]

PART XIII.

I intended to fill the greater part of this page with sample ads. written by me on the subject of belts, buckles, blouse sets, etc. I had the matter ready for publication when the following letter reached me, which I believe ought to have preference. I reproduce the communication all but the signature, because of the urgent request of the writer.

WASHINGTON, Ia., April 25, 1896.  
Editor of THE JEWELERS' CIRCULAR:

Gentlemen: [I expect to go into business. In view of success, I wish some of your valuable advice in the way of advertising.]

I will tell you the situation and the points I wish to know.

I will be located in a city of 10,000, and will have a room in the only opera house in the city, a new one, and I contemplated naming it "The Opera House Jewelry Store." Now, in view of establishing an acquaintance as wide and as soon as possible, would you advise always making "The Opera House Jewelry Store" the only signature to the ad., or would you, in connection, put in the firm name, or would you advise signing the firm name at all?

I realize too much advertising of the proprietors is done, and not enough of the business they are engaged in, and I do not wish to be "sold" as many of the self-advertised are. And, presuming to meet with strong competition, do you think it advisable to advertise specific prices, viz., describe the article, quality and all, plain to all, and its price; or to say we have such a make of goods at such a price, and not state the quality, or to advertise the goods, saying nothing of the price?

Please do not use my name in the publication.

Thanking you for your kindness, I am,  
Respectfully yours,  
X. Y. Z.

Every question will be replied to, but as the correspondent did not tell me in what city he intended to do business, I will take Washington, Ia., as the town for debate.

The correspondent states that he will have room in the only opera house in this city, and because of this would like to name it "The Opera House Jewelry Store," instead of using the name of the firm. I strongly advise the use of the firm's name, adding thereto, not as prominent, "Jewelers and Opticians." Then, "Room—Opera House block."

In the jewelry line it is far better to use the firm's than a fictitious name. The people will acquire confidence quicker with the firm whose name they can learn, than another whose name they are ignorant of. It is *confidence* that rules the jewelry business.

I would by all means advertise one article, with description and price at a time. Further down in this article the reason for it will be given.

Nowadays to start in the jewelry business you must work constantly, with right methods, right goods and right prices. The public will not recognize you at all if you fail to offer them the "best for the least money," besides guarantee to give the money back for any goods upon which the slightest misrepresentation was made.

I say describe one article at a time with the price in the right newspapers, because these newspapers reach the masses, and tell all readers what you have on sale and what you ask for it. Do not fear that competitors will cut into you. If they do, they must buy exactly the same articles as you do, and from the same manufacturers.

This does not happen once out of 100 times; and if it really does, you will have imparted your message to the people quicker than your competitors did. Common sense is my guide when I say that competitors do not know what you have advertised, until they have read the advertisement in the same medium which your prospective buyers get.

The best paper in Washington, Ia., I find to be the Republican organ, *Gazette*, issued Fridays. I would advertise in this paper in every issue, but have a new ad. every time the newspaper appears. I would use as much space as I would find necessary, quoting therein one article with description and price of every department or branch contained in the jewelry store. It should be seen to that every item should be a business-bringer.

This means that the lowest prices of the goods for the advertised day or week be must quoted.

I would by all means mark every article in stock in plain figures, price-figures that even a child can read when picking up any article.

I find that on each Wednesday a Republican and a Democratic organ are issued. The first is called *Press*, the latter *Democrat*. I would not miss at the beginning placing an ad. in these papers in their every issue, but would have every time a different ad. in each paper. In this way you can learn which paper gives the best returns. Do not figure how many people buy the advertised article, but how many ask for it, or buy something whether advertised or not. According to the goods you advertise in the papers will be the class of trade you obtain. The lower priced goods, directed at even the better class of people, occasionally will sell this trade higher priced wares.

The only way to buy newspaper space is by the inch, the space to be used as wanted. Of course you can calculate how much money you can invest in advertising in a year, and make inch contracts with newspapers according to quality and quantity of circulation, giving the best most space, and so on. After this has been accomplished, pick out the style of type you would like your ads. to appear in, and make this type-style a kind of trademark for your ads. If the majority of firms use borders around the ads., you had better use white space around them, otherwise use a catchy border.

In writing your ads. be sure to come right down to business from the start. People nowadays have not time to read much; they want to read little that contains much.

To make advertising profitable your show cases and show windows should be pleasing to every eye; your store should be likewise.

Make it a rule right from the start not to advertise in anything

but newspapers. Avoid all programmes, schemes and the like. You can do this without slighting a single customer, by stating to all that you have positively decided not to advertise in any such mediums. To show them your sincerity, tell the solicitors for ads. that you will by a ticket for the affair, instead of engaging space. Adhering to this rule is sure to save you lots of money in a year.

If you can spend more than for newspaper advertising, get up a little booklet; make it neat, short and to the point. Tell in it what goods you have for sale, and what they can be purchased for. Fear no competition. Have the booklet delivered through the mails, under letter postage. Another good way to advertise is to have letters printed weekly, in the new typewriter style, and send them to your customers, and the trade you intend to cater to. Mail each week or two a new letter with new items.

**H. D. BURGHEIM** recently removed from 9 S. Illinois St. to 41 W. Washington St., Indianapolis, Ind. He announced his removal by offering a ladies' gold watch to the person guessing who would be the manager of the new Washington St. jewelry store. Below is an advertisement which shows the style of his ads. since removal.

**A Wide-Awake Merchant Inter-viewed. Burgheim's, 41 Washington St.**

REPORTER: Aha! Burgheim, you are right in the swim, around on Washington. What a beautiful place!

BURGHEIM: Yes, I wheeled around the corner to these commodious quarters, one of the brightest establishments in the boulevard.

REPORTER: Have you advanced prices on your watch repair work, here on the thoroughfare?

BURGHEIM: Not a farthing. True, a handsome place means additional expense.

REPORTER: How do you overcome it?

BURGHEIM: More work is what I am after. My name is a synonym of "The lowest prices on watch repairs in the world," and old fogey Washington St. jewelers' prices cannot change my low, old landmark prices.

REPORTER: So you mean to keep up watch cleaning at 50 cents, main springs, 50 cents, here at 41 W. Washington?

BURGHEIM: You just put it in *The News*, and add that I do for \$1 just \$2 worth of work, and a little more than that.

REPORTER: Would have my watch cleaned, but—

"But what?" Burgheim hastily asked. "She is like you, old boy—in the swim—she is in soak. Good day."

**Burgheim's Prize Offers. Three Special Prizes.**

For the three best twenty-line (news column) verse, bearing on watch repairing.

First prize—A \$15 clock.

Second prize—Set table and teaspoons.

Third prize—Set knives and forks.

Must be ready for publication May 10. For particulars apply or address BURGHEIM'S, 41 W. Washington.

# The "Safety Case" FOR Riding Specs.

## SOMETHING NEW . . . .

THIS INGENUOUSLY MADE CASE FILLS A LONG FELT WANT. IT IS STRONG, COMPACT, DURABLE AND CONVENIENT.

Ask Your Jobber for Them.

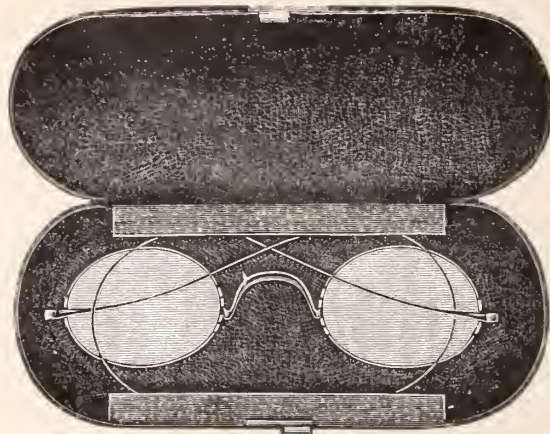

(PATENT APPLIED FOR.)

OUR REGULAR "SAFETY CASE," OF SIMILAR PATTERN, BUT SMALLER, IS THE BEST CASE EVER MADE FOR FRAMELESS, OFFSET EYEGLASSES.

For Sale by all Jobbers

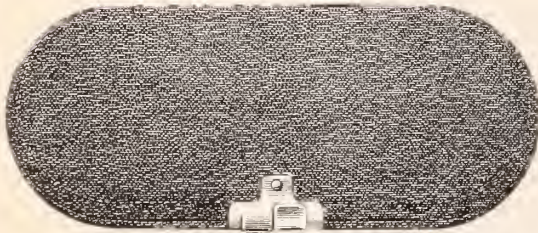

## SUSSFELD, LORSCH & CO.,

13 Maiden Lane, N. Y.

### THE SPENCER OPTICAL INSTITUTE

THE RECOGNIZED OPTICAL SCHOOL FOR BUSINESS MEN

OUR COURSE PRACTICAL COMPREHENSIVE NONCLASSICAL IN THEORETICAL AND APPLIED OPTICS

SEND FOR APPLICATION BLANK & PROSPECTUS. CLASSES CONVEENE 1ST TUES. EACH MONTH

OUR STUDENTS ARE THE SUCCESSFUL OPTICIANS

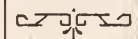

SPENCER OPTICAL MANUFACTURING CO. 15 MAIDEN LANE . N. Y.

WM. SMITH & CO., 5 and 7 MAIDEN LANE, NEW YORK. 61 PECK ST., PROVIDENCE, R. I.

ESTABLISHED 1854.

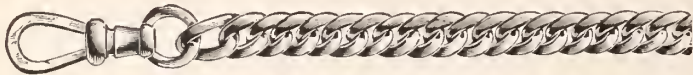

MANUFACTURERS OF

## Gold, Silver and Rolled Plate Chains and Jewelry.

Novelties in Gold and Silver Bead Necklaces and Bracelets. Also a large line of Chain Trimmings and Silver Rings.

## AIKIN, LAMBERT & CO.,

MANUFACTURERS OF

FINE GOLD PENS, HOLDERS, PENCILS, TOOTH PICKS, and NOVELTIES.

PAUL E. WIRT FOUNTAIN PENS, at new and lower prices . . .  
MERCANTILE FOUNTAIN PENS, guaranteed to give satisfaction.

Catalogues with terms and discounts furnished to the trade.

BRANCH, 103 STATE STREET, - - - CHICAGO.

## AIKIN-LAMBERT JEWELRY CO.,

IMPORTERS OF

### DIAMONDS.

JOBBERS IN

WATCHES, JEWELRY, CHAINS NOVELTIES, ETC.

LATEST DESIGNS.

LOWEST PRICES

19 MAIDEN LANE, NEW YORK.

SEND FOR A CIRCULAR OF OUR FRAME AND LENS

\$6.90. CABINET. LESS 6%.

JOS. FRIEDLANDER & BRO.,

WHOLESALE OPTICIANS,

9 MAIDEN LANE, - - - NEW YORK.



Send 40 Cents For sample of our steel E. G. frame with Imperial guard in Imperial case. Levy, Dreyfus & Co., Wholesale Opticians, 9-11 Maiden Lane, New York.

## DR. KNOWLES' PRIVATE COURSE IN OPTICS.

Lectures with Diploma \$25.00

Those who desire to study with the Doctor will send in their application.

Students received at any time.

CORRESPONDENCE COURSE PERFECTED.

The Key to the Study of Refraction.

50c. per copy,

For Sale by

R. H. KNOWLES, M. D.,

189 Broadway, NEW YORK.

Care of JEWELERS' CIRCULAR.

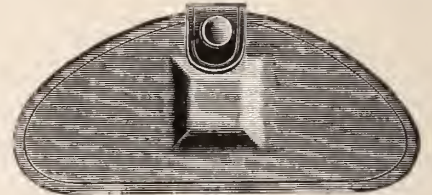

EXTRA THIN.



IN TWO SIZES.

## KOENEN'S NEW SHELL CASE

FOR OFFSET EYEGLASSES.

THE LATEST AND BEST. THIN AND STRONG.

Manufactured and Patented by

A. KOENEN & BRO., 81 Nassau St., N. Y.

SOLD BY JOBBING TRADE.

# OPTICAL DEPARTMENT.

## Ocular Refraction.

AS RELATES TO THE CORRECTION OF VISUAL DEFECTS\*

BY R. H. KNOWLES, M. D.

**NOTE.**—The purpose of this series of articles is to give to the student without his having had any previous technical education, a clear and practical course of instruction in optics with its application to the fitting of glasses. The Correspondence Column is open to all readers of THE JEWELERS' CIRCULAR. All questions asked will be fully answered.

XXXII.

(Commenced Feb. 27, 1895.)

### CHAPTER VII.

**U**NDER Asthenopia, which may be considered the acute stage of squint, and strabismus, the chronic stage, Dr. Geo. Stevens has devised a series of technical terms expressive of the normal standard relative to muscular equilibrium either as to actual tendencies or actual deviations from that standard.

#### ASTHENOPIA, OR WEAK SIGHT.

The acute stage of squint.

1. *Orthophoria.* A tending of the visual lines in equilibriums.

2. *Heterophoria,* tending of the visual lines in any other way than normal, abnormal tendencies of visual lines.

- (a) Esophoria, tending inward.
- (b) Exophoria, tending outward.
- (c) Hyperphoria, tending of one eye above its mate.
- (d) Hyperesophoria, tending inward and downward.
- (e) Hyperexophoria, tending outward and upward.

#### STRABISMUS,

or chronic form of squint.

1. *Orthotropia,* a normal balance of the muscles relative to squint.

2. *Heterotropia,* some form of squint.

- (a) Esotropia, convergent squint.
- (b) Exotropia, divergent squint.
- (c) Hypertropia, deviations of one eye above its mate.
- (d) Hyperesotropia, deviations inward and downward.
- (e) Hyperexotropia, deviations outward and upward.

ACCOMMODATIVE ASTHENOPIA is that form of weak sight due to some form of hyperopia, either simple hyperopia, simple hyperopic astigmatism, compound hyperopic astigmatism, or hypero-myopic astigmatism. In simple hyperopia where the axial diameter of the eye is too short, the motor-oculi stimulates the sphincter-iris or the circular fibers of the

\*Copyrighted 1895, by the Jewelers' Circular Pub. Co.

muscle of accommodation into activity, thereby rendering the crystalline lens convex enough for the distant point to appear in vision equal to that of the normal standard; in addition to which the tendency of the eyeball is to rotate inward, as the motor-oculi also controls the movements of the internal rectus together with that of the superior and inferior recti, and the inferior oblique muscles, so that in the act of extra accommodation the eyes tend to converge, thus bringing about a strain upon the external rectus muscle and the consequent asthenopic symptoms. Thus we have a tendency in simple hyperopia of the eyes to turn inward and the convex tendency of convergence is in the horizontal plane.

In simple hyperopic astigmatism the strain is placed upon the superior oblique muscle of

In hypero-myopic astigmatism the strain is placed upon the external rectus and the superior and inferior recti, so that the tendency of the eyeball is to rotate at an angle of 45 degrees inward and upward with one eye if for instance, the right eye, due to the strain placed upon the external and inferior recti and the left eye permits of the same tendency, because of the strain placed upon the external and superior recti.

Other things being equal, if the eyes are in emmetropia the muscles controlling the movements of the eye will be in balance; this, of course, leaves the reflexes out of our calculation, so that if the eyes are not in emmetropia the muscles relatively will be out of balance. The writer, therefore, places the relation between vision and muscular equilibrium as one is to four; in other words, if there is one diopre of hyperopia there will be four degrees of esophoria.

(To be Continued.)

## A Time-Saving Clock.

"**I** CALL it my time-saving clock," said a Wall Street broker to a *Mail and Express* reporter yesterday, pointing to a clock with a large dial, in a conspicuous position on the broker's roll-top desk. "You will notice that when you are seated beside me you can't help seeing it. Now keep your eyes on the hands."

The broker stretched one leg under his desk, and at once the hands of the clock began to turn. They moved from 11.20 o'clock to 1.30 o'clock in about three seconds.

"I called your attention to the clock face simply to show you how it was done," explained the man of stocks, "but I don't do that when I want to make practical use of it. You see, I am greatly annoyed by visitors who have no conception of the value of their own time or mine, and I devised this scheme to get rid of them. I got an electrical friend to connect the clock-works with a push-button which I can touch with my foot. When a man gets to be a bore, I pick up a railroad time-table, which I have handy, and hold it up in front of him. At the same time I touch the button and set the time on, say an hour.

"Then I say, 'Well I've got to get a train pretty soon.' Of course, the first thing my visitor does is to look at the clock, and he is usually surprised at the rapid flight of time. Sometimes he will look at his watch for confirmation, but I always swear my clock is run on electrical time and cannot possibly be wrong. That usually starts him.

"I had to put the clock up three hours the other day on a long-winded fellow. It was at 10 o'clock in the morning, and I pushed the hands along to 1 o'clock. Would you believe me, it actually made him hungry, because he thought it was lunch time?"—*New York Mail and Express.*

"THE CIRCULAR is well worth the money."  
EDMUND SCHEUER, Toronto, Can.



ACCOMMODATIVE ASTHENOPIA. 1 DIOPRE HYPEROPIA.  
4 DEGREES ESOPHORIA.

one eye, and the inferior oblique muscle of its mate, and the tendency of convergence is in the vertical plane or very nearly so.

In compound hyperopic astigmatism the external rectus muscle, together with the superior oblique muscle of one eye and the inferior oblique muscle of its mate are weakened, and the convergence is midway between the horizontal and the vertical planes, or, in other words, at 45° in and down toward the horizontal plane in one eye, and 45° in and up with the other eye.

# THE BRAND,

The unquestionable brand,  
The brand of all brands,  
The first of all brands,  
The tried and true brand,

It's  
The



"ANCHOR" BRAND

## SILVER PLATED WARE.

It counts for everything that's good and true and of artistic design in **Silver Plated Ware.**

No one else makes it. No one makes its equal.

**WM. ROGERS  
MAN'F'G CO.,**

Office and Salesrooms: Hartford, Conn.

FACTORIES:  
Hartford, Conn.  
Norwich, Conn.  
Taunton, Mass.

There is no longer any uncertainty about belt pins this season. They will sell, are selling. We make a very large and complete line, at lower prices than ever before. Use the pin stamped "Pat. April 3rd, 1888" if you want the best.

All silver not less than 925-1000 fine.



**B. A. BALLOU & CO.,**  
61 Peck Street,  
Providence, R. I.

## STERLING SILVER . . . . . TABLE WARE

Manufactured at  
**NEWBURYPORT, MASS.**



**TOWLE  
MANUFACTURING COMPANY.**

CHICAGO OFFICE: 149-151 STATE STREET.

## THE SWAN FOUNTAIN PEN

Reputation World Wide.  
Made upon Distinct Principles.  
Is a Compressed Air Pump.  
Simply Wet the Insides to Provoke  
an Energy.

**W. W. Stewart, Inventor and Patentee.**

A variety of Styles and Prices

- 3 Sizes Safety Swans.
- 3 Sizes Self-filling Swans.
- 3 Sizes Adjustable Swans.

**MABIE, TODD & BARD,**

NEW YORK AND LONDON.

ESTABLISHED 1870.



TRADE MARK.

## FINE CASES,

For Jewelry, Silverware, Etc.  
HARDWOOD CHESTS,  
TRAYS AND SAMPLE CASES.

**Samuel C. Jackson's Son,**

180 Broadway,  
New York.

## The Bonner Combination

RING, STUD and SCARF PIN.  
A Long Screw and a Round Bezel.

Send for Selection Package

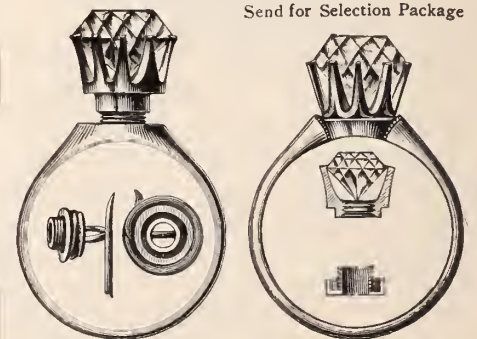

**BONNER, RICH & CO.,**

41 & 43 Maiden Lane, NEW YORK,  
604 Champlain Building, CHICAGO.

**JACOT & SON,**

Importers and Manufacturers of

## Musical Boxes,

39 Union Square, New York.





## The Rambler's Notes.

WHAT THE RAMBLER SAW AND HEARD AMONG THE DEALERS IN ART POTTERY, CUT GLASS, BRONZES, ETC.

### POPULARITY OF VERONA GLASS.

VERONA, the beautiful new production in glassware of the Pairpoint Mfg. Co., mentioned in this column recently, is proving a very successful line with the jewelry trade. A feature of this ware lies in the ornamentation of flowers or figures which appear in transparent crystal outlined with gold, while the remainder of the glass bears attractive translucent coloring. The assortment of vase and flower holders in this ware, at the Pairpoint Mfg. Co.'s New York salesrooms, 46 Murray St., is now very large.

### NOVELTIES IN CARLSBAD CHINA.

THE largest collection of novelties ever shown by Charles Ahrenfeldt & Son, 52 Murray St., New York, in their own Carlsbad China, may now be found on the fourth floor of their building, 52 Murray St., New York. Among the articles in which a variety of styles, sizes and decorations are shown may be mentioned china-backed hair and clothes brushes, whisk brooms, combs, mirrors, spirit lamps, atomizers, toilet sets, manicure sets, desk sets, boudoir sets, bon-bon boxes, vaseline bottles, card boxes, trays, large and small photo frames, lamps, vases, clocks, and a fine assortment of loving cups. Among the principal decorations in this line are the small field flower, Dresden flower and Watteau panel styles.

### NEW GOODS IN BONN.

BEAUTIFUL panels and plaques in Imperial Bonn ware are to be seen in the warerooms of C. L. Dwenger, 35 Park Place, New York. They come in various rococo and round shapes and show the Berlin decoration with its beautiful combination of flower colors. Many fine large garden pots, pedestals, jardinieres and umbrella stands are also here to be found.

### REPRODUCTIONS OF ANCIENT WEAPONS.

AN interesting collection of facsimiles of ancient historical war weapons, armor, chains, etc., is displayed by the Chas. Jacques Clock Co., 22 Cortlandt St., New York. The reproductions

are very carefully and artistically made in papier-maché, being exact copies of the original pieces, representing old iron, steel, wood brass, copper, bronze, gold and silver, and make most beautiful decorations for studios, libraries, club rooms, theaters, lodges and meeting rooms. The original historical weapons from which these were modeled are on exhibition at the British Museum, Hotel Des Invalides, Royal Brussels Museum, Mount Vernon, Museum at Rome, Cluny, Berlin, Athens, etc.

### BEER MUGS IN GREAT VARIETY.

NO finer assortment of beer mugs of all descriptions could be desired for selection by the jeweler handling these products, than is contained in the line shown by Hinrichs & Co., 29 Park Place, New York. English Tobys, Metlach and Flemish beer mugs are among the wares shown in many sizes, in addition to an extensive collection of large and small old German tankards in antique styles and colors decorated with arms and inscriptions.

THE RAMBLER.

## Tale of a Pet Ostrich and a Clock

A SUN reporter was standing in front of an up-town bird store window looking at some strange specimens of the feathered kingdom on exhibition, when a man, who might have been anything, as far as appearances went, from a scientist to a millionaire, without being either, sidled over toward him and began the conversation.

"Odd-looking fowls, ain't they?" he asked in a jerky kind of language.

"Rather," responded the reporter. "What are they?"

"Indeed, I don't know. I'm so little of an ornithologist that I can't tell a this Spring's spring chicken from a last Spring's spring chicken. I can't."

He smiled through a faint shadow of regret.

"You must live in a boarding house?" ventured the reporter.

"That's right."

"And naturally, or logically, rather, you must be a bachelor."

"More's the pity."

"Verily; but a bachelor can find some comfort in the possession of pets, and birds are pleasant pets. Haven't you ever kept any birds about?"

The man sighed profoundly and made as if to brush away a rising tear.

"I had a pet ostrich once," he said sadly.

"That was rather a cumbersome pet, wasn't it?"

"At least it wasn't an elephant on my hands," the man smiled sorrowfully, and the reporter let the poor joke go as a kind of a sunbeam through the clouds.

"Got it yet?" inquired the reporter.

The man shook his head.

"What became of it? Landlady use it as a Thanksgiving turkey?"

The man looked so hurt that the reporter hastened to apologize.

"Let me tell you about my pet," said the man, with a quivering lip. "It was presented to me by a friend who was a ship captain. He used to keep it on the ship, but he died one day and left the bird to me. He was a fine fellow—the bird, I mean, but so was the Captain, for that matter—and was so nearly acclimated that I didn't have much trouble taking care of him. I had a nice warm place for him in the barn, and when I was in my room I had him in there with me. Of course, he took up a lot of space, and banged the furniture around sometimes when he took a notion to kick and be playful, but I rather liked that, for he made it so lively that I forgot I was a lonely old bachelor. You know what an appetite an ostrich has?"

The reporter nodded.

"This one was built that way and on very generous lines," continued the man. "He used to eat the pictures off the walls, or tried to, but after a few weeks living with him I got onto his curves, so to speak, and put everything out of his reach that he could swallow or that seemed to be appetizing to him, and we got along famously. During the second Summer of his residence under my roof, I had some work to do that called me out of bed at seven in the morning, an hour earlier than my usual rising time, and I bought a small alarm clock to rouse me on time. It was one of these little round fellows, but like a small man with a bass voice, it could emit a tremendous volume of sound when it got started. One morning I was disturbed about six o'clock by a noise in my room, and sitting up in bed, discovered my ostrich nosing around, stumbling over the furniture, and sizing up a piece of bric-à-brac or two I had nailed down on a cabinet for safe keeping.

He had come in through a window that opened down to the floor of a piazza, and was having a nice quiet time all to himself. I said "Good morning" to him, and right away he came over to the bed and tried to make a breakfast off the blanket, but I batted him over the head with a pillow, and then we had a great romp. It occurred to me after we had been monkeying for some time that I had better be seeing what time it was, and I reached over to the table by my bed to get my clock. It wasn't there and I suspected the ostrich at once.

"I knew it was about a mess for him, and was not altogether pleased with the idea of paying 98 cents for a lunch for an ostrich, and I called him down. I pointed at the place where the clock had been, and then run my hand down along his neck and asked him what he knew about it. He was smart, but hardly knew enough to understand my sign language, and I didn't get any satisfaction out of my cross-examination. I found by my watch that it was nearly getting-up time, and, giving him a final bat over the head with a pillow, I got out of bed and began making my toilet, the ostrich meanwhile sitting up in my bed as if it were his nest, and watching me with apparent great interest.

"As I stood before my glass combing my hair, I heard a peculiar whirring sound, and looked quickly around at the ostrich. The look of surprise on his face was peculiar, and seemed to be divided between himself and me. Then he stretched his neck over the side of the bed and looked under it, and again looked at me, this time much more in doubt

than before. I knew what that whirring was now, and it struck me as being so ridiculous that I snorted with laughter. But it wasn't funny to the bird. The whirring was now going on at a terrific rate, and the clock was evidently jumping about under the strain. Anyway, the ostrich seemed to understand, without exactly understanding, and all at once he let loose a wild squawk of fear, and dashed through the window, across the piazza, and over it to the ground below, tangling himself up in a wire screen as he went. I followed him, laughing fit to bulge my diaphragm, and when I reached his side—alack and alas—my laughter changed to weeping, for the poor fellow had broken his neck in the fall, and when I bent over him he gave one little gasp and shut his eyes forever, and the whirring inside of him died away in a wail that sounded like a cry of desolation. Now," concluded the man with tears in his eyes, "do you wonder that I never cared to have any more pets to lavish my lone affection upon?" and the reporter unfeelingly inquired if he performed an autopsy on the ostrich to recover his 98-cent clock and did it keep good time afterward.—*New York Sun.*

**Separating Gilding from Base Metals**—It is necessary for this operation to first granulate or in some way reduce the metal mixture into a comminuted state. When done, take for each 500 parts 8 parts saltpeter, 40 potash, and 20 powdered white glass; first mix the ingredients by themselves, then stir them carefully with the granulated metal,

put the whole into a new Hessian crucible, leaving about 30 millimeters (about 1 1-6 inches) space on top. Next reverse a somewhat smaller crucible over it and lute it with cement in such a manner that the smaller crucible enters a trifle with its lower rim. Previously perforate the bottom of the upper, having the hole about the size of a goose quill. When all this has been done expose the whole at first to a gentle heat, which increases gradually until the crucible glows with a feeble red glow. Maintain it at this point for about one hour to one and one-half hours. You will soon have the mass working within and a flame will issue from the upper hole, burning like a candle. As long as this continues the crucible is to be kept at this temperature. When this condition has ceased increase the fire in order to melt the matter in the crucible, and retain it for about fifteen minutes in a fluid state; then let the fire cool down until everything is cold. Lift out your crucible, break it, and you will find three layers, one above the other. The upper consists of the flux; the second is metal slag; the third is that of the precious metal, either fine gold or fine silver alone, or if both were contained in the mass, then both together. The upper two layers are separated with a hammer as closely as possible from the lower, and this is re-melted in another crucible. When in flux, (if the mass amounts to 500 parts), add little by little forty parts saltpeter and 20 parts refined potash, well mixed previously. When well melted, pour, and the precious metals will be found in a pure condition.

# BAWO & DOTTER BULLETIN

## HALL CLOCKS===CHIMING CLOCKS.



GIL ENGRAVED ORNAMENTS RAISED FIGURES—DIAL 42 234

**New Cases now ready**—made of oak or mahogany—carved inlaid or trimmed with bronze ornaments—in a great variety of new and beautiful designs. All our cases are made in this country and the material, workmanship and finish is unequalled. **MOVEMENTS**—Elliot's automatic chimes, on musical bars or gongs—Elliot's gong chiming movements with 5 or 9 gongs, and with and without the 8 cup bells, etc.

English recoil and dead beat, hour and half strike, weight movements with beautiful dials.

**B. & D.'s new weight movement.**

**A LARGER OR BETTER STOCK CANNOT BE FOUND.**

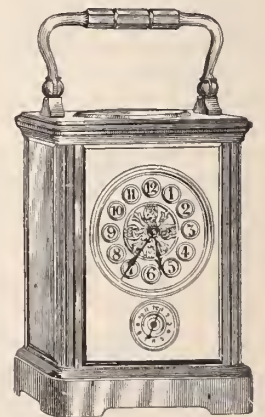

**TRAVELING CLOCKS.**  
Large stock on hand.  
Timers—Strikers—Repeaters—  
¼ Strikers.

**BAWO & DOTTER,** Manufacturers, Importers and Commission Merchants,

26, 28, 30 and 32 BARCLAY ST., NEW YORK.

**MELISHEK & PETTER.**

128 Maiden Lane, New York.

MANUFACTURERS OF  
WALL AND COUNTER CASES,  
FOR JEWELRY, SILVER-  
WARE, ETC.

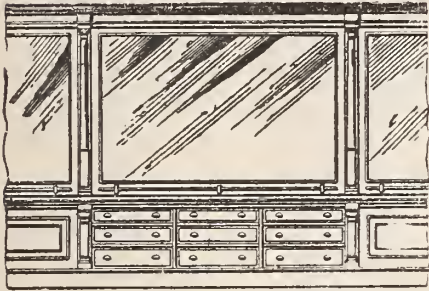

WE make to order only, and guarantee our work to be Dust Proof and First-Class in all its details, and to have all the Latest Improvements as regards Shelf Arrangements, Electric Lights, Etc. We will cheerfully furnish Estimates and Sketches for any store free of charge

CALL AND SEE US.

ESTABLISHED HALF A CENTURY.

**MARVIN'S**  
FIRE & BURGLAR  
**SAFES**

HAVE MANY PATENTED IMPROVEMENTS NOT FOUND IN OTHER MAKES THAT WILL WELL REPAY AN INVESTIGATION BY THOSE WHO DESIRE TO SECURE THE BEST SAFE  
**MARVIN SAFE CO.**

12 PARK PLACE, NEW YORK.

**CROUCH & FITZGERALD.**



Jewelry Trunks and Cases,

161 Broadway,  
Bet. Cortlandt and Liberty Sts.,  
688 B'way,  
701 6th Ave.,  
NEW YORK.

**SURPASSED ALL RECORDS!**

AT THE OBSERVATORY OF GENEVA, OUT OF TEN MOVEMENTS (*CONSECUTIVE NUMBERS*.) THE

**CHAS. MEYLEN WATCHES**



OBTAINED  
2 First PRIZES,  
4 MEDALS  
AND  
4 DIPLOMAS.



**MATHEY BROS., MATHEZ & CO.,**

— SOLE AGENTS, —

21 AND 23 MAIDEN LANE, NEW YORK.

PLAIN AND COMPLICATED WATCHES.

**ENAMELED AND DIAMOND WATCHES.**

**AJAX INSULATORS.**

PATENTED OCTOBER 28, 1889.

THEY are Cheap; THEY Reduce Wear and Tear of the Case;  
THEY Protect from all Ordinary Magnetic Influences.

Perfect in  
Action.  
Convenient  
in Use.



Educate  
Your Customers  
by Talking  
up  
Ajax Watch  
Insulators.

MADE IN ALL SIZES, OPEN FACE AND HUNTING.  
FOR SALE BY JOBBERS.

MANUFACTURED BY

**The Newark Watch Case Material Co.**

19 WARD STREET, NEWARK, N. J.



**CYCLING PROGRESS  
EXEMPLIFIED.**

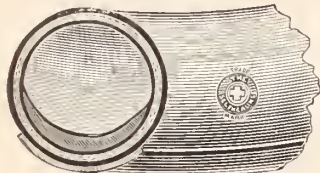

**THE WONDERFUL  
SELF-HEALING TIRES**

are single tube, finest rubber, finest wove Sea Island cotton fibre, re-enforced inside and outside on tread, and no better tire can possibly be made. They are fully guaranteed against all climatic changes, are the most resilient ever made, and when punctured instantly heal the wound of their own volition.

THEY WEIGH NO MORE THAN OTHERS,  
COST NO MORE,  
AND ARE WORTH TEN TIMES MORE.

SEND FOR TIRE BOOKLET.  
Wm. H. CAHN, GENERAL MANAGER,  
48 and 50 Maiden Lane, New York.

BY EVERY TEST THEY ARE THE BEST.  
THE UNIVERSAL FAVORITES.



SUPERB  
**Olympic**  
BICYCLES

For sale by more than 2,000  
Jewelers, and constructed to meet  
the demand for finest quality.  
For Adults and Juveniles.

SEND FOR EXQUISITE  
CATALOGUE.

Top Grade "Olympics" have SELF-  
HEALING TIRES.

Olympic Cycle Mfg. Co.,  
N. Y. Office: 35 LIBERTY STREET.

General Jobbing Ag'ts, S. F. MYERS & CO.,  
WHOLESALE JEWELERS, Myer's Building, New York

**CHAS. JACQUES**



**CLOCK  
CO.,**  
22 Cortlandt St.  
NEW YORK.

Hall Clocks,  
Traveling Clocks,  
Gilt Clocks,  
Porcelain Clocks,  
Delft Clocks,  
Mantel Chime  
Clocks,  
Bronzes,  
Sevres Vases.

- - EMMONS - -  
ASSOCIATED LAW OFFICES.  
PORTLAND, SEATTLE, TACOMA,  
Oregon. Wash. Wash.  
Foreign Business a Specialty.

**BAWO & DOTTER,**

26-32 BARCLAY ST.,  
NEW YORK.

P. O. Box 1872.

NO LARGER STOCK  
OF

**HALL  
CLOCKS**

IS SHOWN IN  
THIS CITY.

Large Stock  
OF  
MOVEMENTS.

NEW DESIGNS  
IN CASES.



**DUBOIS WATCH CASE CO.**



FINE HAND MADE  
**SOLID GOLD CASES.**

A PRIDE TO THE MAKER,  
DEALER & WEARER.

**L. LELONG & BRO.,**

GOLD AND SILVER

Refiners, Assayers AND Sweep Smelters,

◁ SOUTHWEST CORNER HALSEY AND MARSHALL STREETS, ▷

**NEWARK, N. J.**

SWEEPINGS A SPECIALTY.

**STERLING**

SHEET AND WIRE SUPPLIED ALL SIZES.

J. SCHAWEL & CO.,  
Gold, Silver and Platinum Refiners.  
29 John Street, N. Y.

ALBERT LORSCH.

ALFRED KROWER

**ALBERT LORSCH & Co.,**

LORSCH BUILDING

37 & 39 Maiden Lane,  
NEW YORK.



167 Weybosset St.,  
PROVIDENCE, R. I.

IMPORTERS OF DIAMONDS, RUBIES, EMERALDS, ETC.,  
AND IMITATION STONES THEREOF.

•• Fine Miniatures on Ivory and Enameled Paintings. ••

**WE WILL CONTINUE TO MANUFACTURE**

Our Fine Mountings at our present location No. 11 Maiden Lane, New York, till May 1st, 1897 when the buildings are to be removed.,

**HENRYE. OPPENHEIMER & CO,** OFFICE: 14 MAIDEN LANE, NEW YORK.

DIAMONDS and Cutters. L. & M. KAHN & CO., 172 Broadway, Cor. Maiden Lane, N. Y., DIAMONDS

# THE JEWELERS' CIRCULAR

AND HOROLOGICAL REVIEW

Copyright by THE JEWELERS' CIRCULAR PUB. CO.

189 Broadway, New York.

Entered at the Post Office in N. Y. as second-class matter

VOL. XXXII.

NEW YORK, WEDNESDAY, MAY 20, 1896.

No. 16.

## SCOTLAND AND ITS NATIONAL GAME IN SILVER AND ENAMEL.

A MONTH or more ago, the design of the women's golf championship trophy presented to the United States Golf Association by Robert J. Cox, M. P., of Edinburgh, was described in these columns. The work of art has just been completed and is illustrated here. The trophy itself, which is a cup, has been on exhibition for the past week at the store of the makers, Geo. W. Shiebler & Co., 179 Broadway, New York, and will soon be taken directly to the Morris County Golf Club, which will have the custody of it until the championship tournament has been played on the links of that club. A design drawing of the cup was sent to Mr. Cox, in Scotland, by Geo. W. Shiebler & Co. and received his entire approval. When won, the trophy is to remain in the custody of the club of which the winner is a member, and it will be offered anew each year as a perpetual challenge.

Delicacy and art, rather than massiveness, are features of the cup's modeling and ornamentation. The form resembles that of an Etruscan vase, of graceful proportions, 24 inches high and 6 inches in diameter. While silver forms the basis of the material, there is a great deal of enameling, which gives variety to the design. On the base of the cup the enamel shows the deep toned green and purple colors of some of the Scotch plaids. The enamel is in dull finish, and thus the texture of the plaids is realistically simulated. In the midst of this enamel work appears the seal of St. Andrew's (Scotland) in the form of an ancient silver coin. Around the base is an inscription explaining the origin of the trophy. The stem of the base rises from a cluster of silvery-green thistle leaves, gracefully twined, with here and there a thistle bloom. Above the leaves there is a space of open silver work, which is surmounted by an elliptical panel. On the ob-

verse side this bears, in delicate painting, on enamel, a representation of St. Andrew's

on the reverse side. Thistle leaves make a band around the vase between the two panels.

At the mouth, in a band of silver, large topaz cairngorms are inserted. The vase is surmounted by a bell shaped cap, adorned with an enamel band, and two panels representing a woman golfer driving and a small bit of St. Andrew's scenery. A thistle in the natural colors forms the top of the cup, and long slender handles complete the design.

### Hindoo Jewelry.

NEVER during its existence has India been so rich in jewelry as now. The people are always adding to their stock. Savings from nearly all sources are disposed of in this way, and these savings are being constantly made—often at the expense of clothing, sometimes at the expense of greater necessities of life. The making and the storing away of wealth in this form is the national peculiarity of the country. Jewelry is regarded as the most stable kind of wealth, and fortunes are never counted without estimating the value of the stock of jewelry. It can always be pledged or disposed of. The market for its sale is never closed and never depressed. The most ignorant native who wishes to sell a piece of jewelry knows its market value quite well. He can scarcely be cheated.

Jewelry forms the greatest factor in matrimony. The most lowly bride has her stridhan, which is occasionally equal in value to five years' income of the bridegroom. There is often a scarcity of clothing, sometimes a scarcity of cooking pots, generally not a particle of furniture, but nearly always a stock of jewelry. The wife that has no jewelry possesses nothing else; she cannot be robbed. The family that does not



WOMEN'S GOLF CHAMPIONSHIP TROPHY.

castle. "The Pends," one of the noteworthy spots on the St. Andrew's course, is depicted

have jewelry is absolutely indigent. One of the greatest boasts of the jewelry

# WE MAKE THE FINEST STYLES

OF STERLING SILVER BUCKLES MOUNTED IN  
LEATHER OR SILK WEBBING.

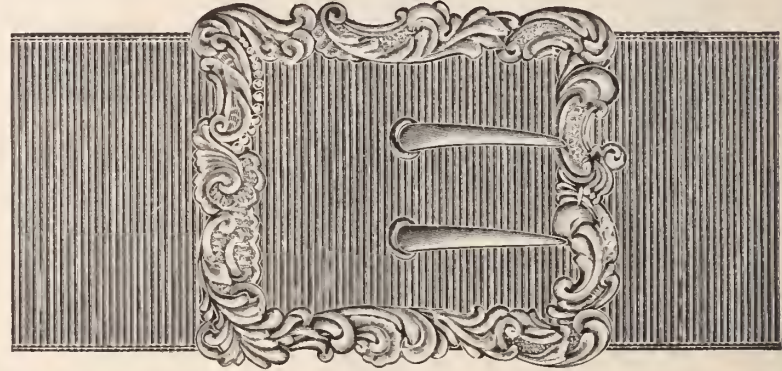
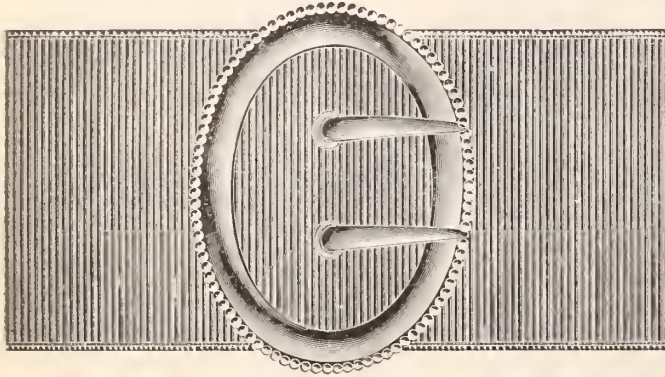

NEW YORK OFFICE:  
21 & 23 MAIDEN LANE.



BOSTON OFFICE:  
403 WASHINGTON ST.

## KENT & STANLEY CO., LTD.,

PROVIDENCE, R. I.

**THE SPENCER OPTICAL INSTITUTE**  
THE RECOGNIZED OPTICAL SCHOOL FOR BUSINESS MEN

OUR COURSE PRACTICAL COMPREHENSIVE NONCLASSICAL IN THEORETICAL AND APPLIED OPTICS

OUR STUDENTS ARE THE SUCCESSFUL OPTICANS

SEND FOR APPLICATION BLANK & PROSPECTUS. CLASSES CONVE NE 1<sup>ST</sup> TUES. EACH MONTH  
SPENCER OPTICAL MANUFACTURING CO. 15 MAIDEN LANE . N. Y.

### BAND RING MOUNTING



DESIGN PATENTED Sept. 24, 1895.

**CHARLES KNAPP,**  
MANUFACTURING JEWELER,  
41 & 43 Maiden Lane, New York.  
SPECIALTY: SUPERIOR LADIES' and CHILDREN'S RINGS

# “Apparel oft proclaims the man.”



HOLYOKE, MASS., U. S. A.

CHOICE PAPERS

So with our fine note papers, envelopes and papeteries—all our bands, boxes and labels are neat, tasty and artistic and perfectly in keeping with and a credit to the high grade goods with which they are used. Our fashionable stationery is put up in a manner that appeals to people of refined tastes, and it is a line particularly adapted for jewelers. We **do not** sell to dry goods or department stores. Write for samples.

**PARSONS & GREENE Co.,**  
MANUFACTURING STATIONERS,  
HOLYOKE, MASS.

# Don't Sell a Trunk Strap

for a leather belt! Did you ever watch a woman put on or take off a trunk strap, either on a trunk or on herself? Did you ever see the strap thereafter? Then let her try our "ECCENTRIC" belt and see her delight at finding a belt that LOCKS ITSELF just as tight as she desires and opens in a second.

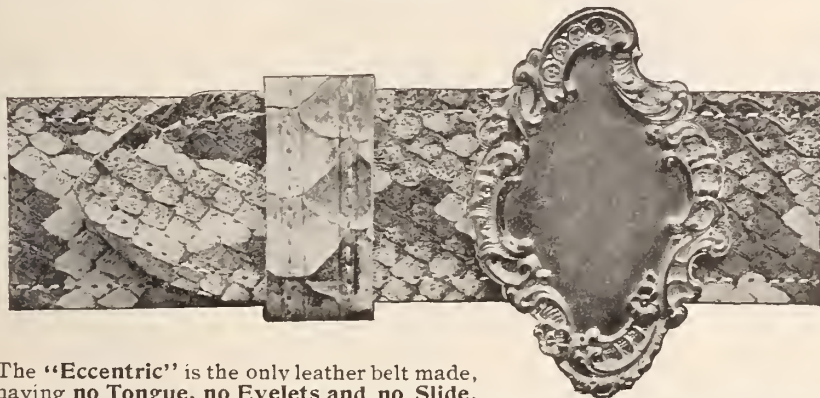

The "Eccentric" is the only leather belt made, having **no Tongue, no Eyelets and no Slide**, that **ADJUSTS ITSELF** and has solid front sterling buckles, which being independent of the belt will enable you to sell several different colored leathers, to match the wearer's dresses, with each buckle.

*Have you seen our Belt Hook, by using which our belt can be worn with a shirt waist?*

**Sold to Jewelers only. Samples on Application.**

**THE FINEST BICYCLE BELT IN THE WORLD.**

**SPIER & FORSHEIM,**



**PATENTEES, NEW YORK.**

31 1/2 Maiden Lane,

## NEW ORNAMENTS

. . . IN . . .

## STERLING SILVER.



Many Designs in

**Galleries, Belt Buckles,  
Belt Slides AND Belt Fastenings,**

**ALWAYS SOMETHING NEW.**

**THOMAS W. LIND,**

Manufacturer of  
**JEWELERS' FINDINGS.**

67 Friendship Street,

PROVIDENCE, R. I.



# Standard Sterling Silver Goods.

**Belts,**

LEATHER, GILT,  
SILVER AND  
SILK WEBBING.

**Waist Sets,**

**Sleeve Links,**

**Hat Pins,**

IN

**Sterling Silver**

AND

**Rolled Gold Plate.**

600 Useful Articles

IN

**Sterling Silver.**



**Foster & Bailey,**

Providence, R. I.

NEW YORK,  
SAMPLES ONLY

CHICAGO,  
SAMPLES ONLY.

owner is that his hoards cannot be taxed. A man may own jewelry valued at a lakh of rupees, and pay no income tax. This is a source of great satisfaction. Jewelry yields no recurring income, but it is prized more than government paper. "If it never increases it never diminishes," is a national saying, common among men and women alike. No native marriage, except among the most impoverished, takes place without a transfer of jewelry, and very frequently of new jewelry.—*Tid-Bits.*

#### Assignment of the Ledig Mfg. Co.

PHILADELPHIA, Pa., May 12.—The Ledig Mfg. Co., with an office at 248 N. 8th St., have assigned to the secretary of the company, John W. Flanagan. The deed is dated May 2, 1896, and conveys no real estate. Mr. Flanagan said that the failure was due to the depression in business and to the refusal of the banks to carry the company's paper at a time when such accommodation would be most helpful. He could give no estimate of the liabilities or assets of the company.

The company manufacture silver, nickel, brass, copper and bronze goods. The officers are: Dr. Berthold Trautman, president; Charles W. Ledig, vice-president and general manager; J. W. Flanagan, secretary, and H. A. Newman, treasurer. The directors are J. G. Donoghue, George Roney, M. M. Newman, Dr. B. Trautman, C. W. Ledig, Oscar Wollheim and W. J. Burdett. The company organized in 1872 and incorporated in 1892. Their authorized capital is \$100,000 and the capital paid in \$68,500.

W. H. Mortimer, jeweler, Pottsville, Pa., offered a gold base ball watch charm to any member of the Heckscherville team who would make a home run in a recent game.

### The Industrial Arts \* \*

(Continued from May 6, 1896)

THERE is another firm whose importance ascends to beyond 40 years; it is that of Gorham Mfg. Co., of Providence, R I., with its largest silversmithing workshops in America, not to say in the whole world, because more than 1,200 workmen are engaged in them. Beside these two immense establishments (Tiffany & Co. and Gorham Mfg. Co.) there are others in the same industry, the houses of Whiting, of New York; Spaulding, of Chicago, etc.

To judge correctly of American goldsmithing, it must be divided into two absolutely distinct branches, like the other industries of that country, to wit, the art proper and the applied art. After the epoch when Moore had made use of the Japanese models, the taste of ornamentation was in jeopardy. A certain Hindoo style, called Saracenic, was introduced for ornamenting the larger part of surfaces with its tortuous arabesques, and for some time it was fashionable. But then efforts were again directed toward the research for new processes. The *repoussé* gave entanglements of flowers in surprising convolutions, assisted by chasing, the delicacy of which was pushed to the last limits. Sometimes it was a low relief of a decoration of figures and country scenes more minute than paintings. Before this epoch Japan had revealed its marvelous secret of imparting to metals all the colors of the palette. Moore sent to Japan for workmen who were set to work to impart

\* Abstract from "La Culture Artistique en Amérique," by S. Bing; translated especially for THE JEWELERS' CIRCULAR from copy forwarded by the Director of the Beaux Arts, Paris, France.

to silver all the varieties of colors. The effect of these incrustations, to which nickel had already been added, was still to be heightened by other systems of colorings. The art of enameling was employed, and here also, sometimes by the use of dull and heavy tones, then again by brilliant and translucent, one attained the maximum of manual skill and ingenuity. Finally, in order to exhaust all the resources, to obtain the last possible effect of richness, the precious stone was used. For a long time, the house of Tiffany had been collecting the most precious jewels offered for sale on the two continents; rough jewels, which they had cut for their special needs; jewels of all descriptions, which belonged to old families; pearls of all shapes and colors. Other material also, such as amber of rare shades, and mother-of-pearl even, which might offer certain effects by its play of light—all were amalgamated into works of different natures, thus offering new features, in which the art of the jeweler was united with that of the goldsmith. Mixtures of still other substances have been tried. Faience, as well as glass, composed for this special purpose, contributed a part.

The highest perfection, the greatest richness as to processes were therefore obtained. What was the result as regards the beautiful? In goldsmithing work as well as in the other American productions, everything may be met with, from the strangest hodge-podge to the most exquisite masterpiece. As an almost general rule, which might appear illogical if analogous facts could not sometimes be witnessed also in our old countries of Europe, the most costly objects are those which manifest the most heart-rending taste in their decorative debauchery. This defect is most plainly visible in all its hideousness, when in

# Dorflinger's American Cut Glass.

Seasonable  
Suggestions.

BE PREPARED FOR  
JUNE WEDDINGS.

C. Dorflinger & Sons,  
36 MURRAY STREET,  
915 BROADWAY,  
NEW YORK.

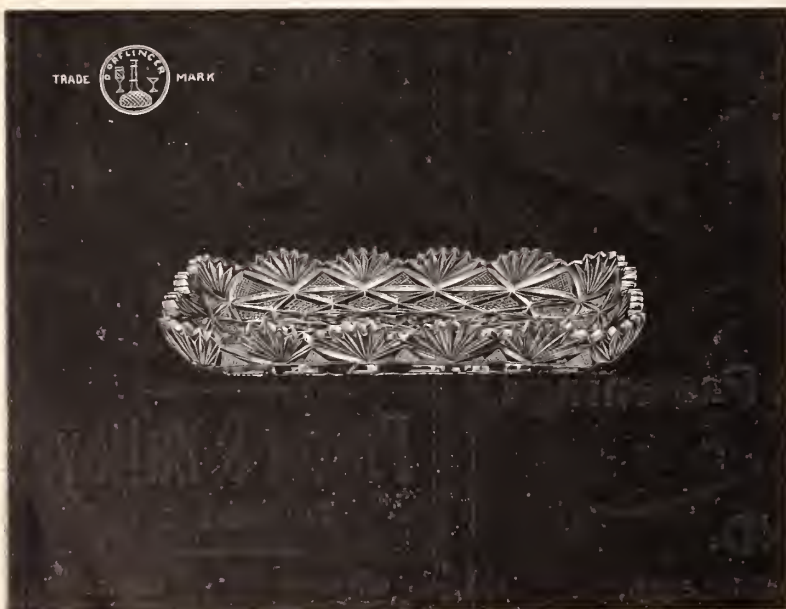

ICE CREAM TRAY.



**COMBINATION  
PURSE AND  
GLOVE  
HOOK.**

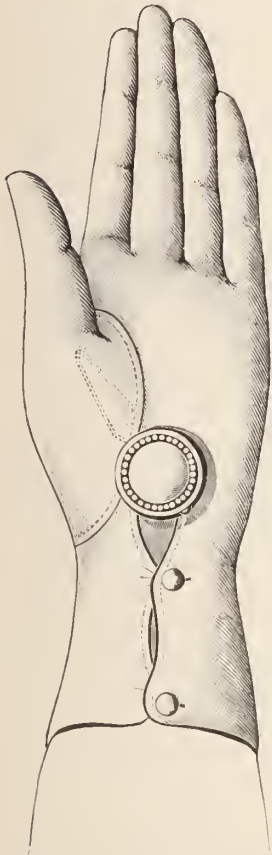

This absolutely new article is bound to have a large sale. It is extremely convenient, serves as an easily accessible carrier for small change such as is required for carfare—is securely held in the palm of the hand and saves its wearer from the insanitary practice of holding coin between the lips.

**A SPLENDID NOVELTY  
MADE IN STERLING SILVER.**



We are makers of Sterling Silverware Exclusively. All goods 925-1000 fine.

**F. M. WHITING CO.,**  
North Attleboro,  
Mass.

**Intrinsic merit**

combined with low prices, makes Cahoone's line for 1896 the most attractive ever offered to the trade.



**Cahoone's rings**

this year are shown in a host of beautiful designs. Particular attention is called to the Imitation Rose Diamond and Opal Combination Rings. Sold by all leading jobbers.

GEO. H. CAHOONE & CO., Kent & Stanley Building, Providence, R. I.  
N. Y. OFFICE, 21 MAIDEN LANE.



**TOWLE MFG. CO.,  
Silversmith S,**

NEWBURYPORT, MASS.

149-151 State St., Chicago, Ill.



**A 1  
MUSLIN BUFFS.**

Sample sent prepaid on request.  
BE SURE to give size of buff and center hole.

**WILLIAMSVILLE MFG. CO.,**

18 South Water St., PROVIDENCE, R. I.  
MILLS: WILLIAMSVILLE, KILLINGLY, CONN.

**This TRADE MARK on CUT GLASS is a GUARANTEE**



of Superior Quality, Design and Workmanship and Unsurpassed Brilliance of Cutting. Our Goods are especially desirable for the Jewelry Trade.

Send for Our New Catalogue ... **STANDARD CUT GLASS CO.,**  
545-547-549 W. 22nd STREET, NEW YORK.



**The STATIONERS' ENGRAVING CO.,**  
98 TO 102 NASSAU STREET, NEW YORK.

MAKERS OF WEDDING INVITATIONS, RECEPTION AND VISITING CARDS  
of the Best Quality, which are offered to Jewelers of recognized standing only.  
Trade Mark "SILVER WHITE," registered.

**DIAMONDS.**  
**Wm. S. Hedges & Co.,**  
 IMPORTERS OF  
 Diamonds and Precious Stones.  
 DIAMOND JEWELRY.  
 170 Broadway, New York.  
 22 Holborn Viaduct, London.

**Alfred H. Smith & Co.,**

IMPORTERS

DIAMONDS

AND

PRECIOUS STONES.

182 BROADWAY, COR. JOHN STREET,  
 NEW YORK.

Venetian  
 Building, 34 & 36 Washington St  
 CHICAGO, ILL.

**Purchasers**

.. OF ..

**RARE GEMS,**

PRECIOUS STONES  
 AND ALL GOODS FOR  
 JEWELRY,

ADDRESS

**R. A. KIPLING, Paris.**  
**19 Rue Drouot, France.**

**L. BONET,**

ESTABLISHED 1866.

**PRECIOUS STONES,**  
 CAMEO PORTRAITS, WORKS OF ART,  
**927 BROADWAY NEW YORK.**

**DON'T FORGET THE JEWELERS' CIRCULAR PUBLISHING CO.'S BOOK LIST** when in want of any technical book in the Jewelry or Kindred Trades.

**SCHULZ & RUDOLPH,**  
 IMPORTERS AND CUTTERS OF  
**DIAMONDS AND OTHER PRECIOUS STONES,**

(Successors to JOHN E. HYDE'S SONS.)

Sole Agents for **The Celebrated Jules Jurgensen Watches.**

28 JOHN ST. and 65 NASSAU ST., NEW YORK.

**The Bowden Rings**

ARE COMPLETE IN VARIETY, CORRECT  
 IN QUALITY AND PERFECT IN FINISH.  
 WE MAKE EVERY VARIETY OF FINGER  
 RINGS.

**J. B. BOWDEN & Co.,**

3 MAIDEN LANE,

 **NEW YORK**

BRANCH OFFICE :  
 206 KEARNY STREET  
 SAN FRANCISCO, CAL.

place of using original ideas, our ancient styles are imitated. It is then like the stuttering of a strange idiom, the sense of which escapes us. That which by us in Europe is saved by certain qualities of grace and native delicacy, is utterly ruined in America by a pretentious heaviness, which denaturalizes even the most seductive types.

But so soon as we approach the familiar domain of articles of utility the practical spirit of the American asserts its rights and becomes striking by its happy, sober adaptation. Involuntarily the artist is drawn away here by the idea of ornamentation which loses sight of the substance used. It is thus that certain tea services, possessing a surfeit of ornamentation, attain to the price of 15,000, 20,000 and even 100,000 francs.

Nothing is more convincing in this regard than the simple beauty of certain pieces of silverware, when they are destined for daily use. The natural ease of the outlines, dictated by practical interest, are a thousand times more charming than all the artificial conceptions. When one desires to enhance the practical structure of the piece by an element of elegance, the ornaments are taken at random from the plant or flower, or from the breathing animal world. Is this turning to nature by Americans due to their contact with Japanese art or is it not rather the result of a still young people, in whom have remained certain primitive inclinations? These two factors doubtless act together.

To sum up, that which in America has made this branch of industry great is due to the unflinching energy of bold men who were at the head. From the very start they have far passed the greatest advances known elsewhere. They collected for their workshops a cosmopolitan colony—English, French and Italian artists—each imbued with the old art of his native country, and in their turn forming new sets of workmen, whose studies were perfected by means of libraries, vast collections of documents, and veritable museums of models, to be found within the walls of the establishments.

For the current objects, such as spoons, forks, knives, and other pieces of table service, a certain number of models were made, more pleasing, more graceful than our old forms, and especially more practical, each model of the service being specially devised for its purpose; and it is by their great simplicity of outlines that they can be reproduced to infinity, by the recent mechanical means, and thus be furnished at moderate prices.

Among the foreign artists who labored to the success of American goldsmithing, the greatest number and by far the most capable came from France; but it is not this industry alone that France has aided in establishing in America. We will find at the foundation of many enterprises plain traces of our national genius.

In matters of ceramic art divers essays are being made, but the majority in a timid manner. One solitary establishment in Cincinnati, the Rookwood Pottery Co., is boldly pursuing

an artistic path. Its productions, by means of colored enamel, very nearly approach the researches made by us for the past few years. The truth is that on both sides of the ocean the beautiful Japanese specimens serve as models. It is probable that in this art America will soon have distanced our efforts, having adopted energetic ways for solving each problem. The Rookwood Co. has, without hesitation, taken Japanese artists as inventors, who have saved them many mishaps.

How much more meritorious are the patient individual researches of our brave French artisans in their strifes against the unforeseen caprices of the fire, having for their only weapons their intimate conception of the beautiful, their ardent faith, and their obstinacy.

**George F. Kunz Analyzes Cecil Rhodes' Character.**

WASHINGTON, D. C., May 12. — Geo. F. Kunz, of Tiffany & Co., New York, lectured last Friday night before the National Geographic Society upon "The Geography of the World, as Illustrated by Precious Stones." In the course of his lecture, Mr. Kunz referred to Cecil Rhodes, whom he calls the Napoleon of the diamond world, and spoke of him in his lecture as follows:

"Rhodes came to Cape Colony as a lad without wealth or influence, but he rapidly created both in the diamond fields, and finally became the controlling power in South African mining and politics. He was made Premier of Cape Colony and Privy Counselor to the Queen. He has been shaping all possible influences to unite the various countries of South Africa into a confederation of colonies, with a single representative government, of which he shall be Governor. His ambition is to live to see a railway and British trade route from Cape Town to Cairo, bringing all the eastern side of Africa under the British flag. He possesses that knowledge of men, and that power to forecast, plan and resolve, and accomplish, which characterize men who achieve great results, and carry out schemes that to others seem impossible.

"Rhodes is a creator, not a wrecker, and for all we may think of the honesty and shrewdness of President Kruger, we must appreciate the fact that advancement in South Africa must be checked for a time, for when Rhodes prospered, everybody prospered. His shrewdness is illustrated by a deal in diamonds with Barney Barnato. The South African Co. needed ready funds. Barnato offered a certain sum for the entire product of the De Beers Mines. Rhodes accepted the offer and dumped the entire stock of diamonds into a bucket, which he delivered to Barnato. Rhodes knew, but unfortunately for himself Barnato did not know that it would take three months to classify the stones ready for the market. Thus the market could only be supplied by the classified stones which had come from other mines belonging to the South African Company. During the three months Barnato was having his diamonds classified for market Rhodes supplied the market with the products of other mines at a greatly inflated value."

ESTABLISHED 1840.

**RANDEL, BAREMORE & BILLINGS,**

IMPORTERS OF

**DIAMONDS,**

AND OTHER PRECIOUS STONES.

**FINE PEARLS A SPECIALTY.**

MANUFACTURERS OF

**DIAMOND JEWELRY**

A Large Stock of Fine Mounted Goods Constantly on Hand.  
Goods Sent on Approval and Insured in Transit.

Diamonds Cut, Recut and Repaired.

58 Nassau Street,  
29 Maiden Lane.  
NEW YORK.

1 Tulp Straat,  
AMSTERDAM.

1 St. Andrew's St.,  
Holborn Circus,  
LONDON E. C.

ESTABLISHED 1841.



**CARTER, HASTINGS & HOWE,**

MANUFACTURERS OF

**GOLD JEWELRY,**

**15 MAIDEN LANE, NEW YORK.**

A. CARTER,

C. E. HASTINGS,  
W. T. CARTER

G. R. HOWE,  
W. T. GOUGH

FACTORY, NEWARK, N. J.

**JOHN P. CAMPBELL,**

MANUFACTURER OF

**WATCH CASES.**

ALL KINDS OF SPECIAL CASE WORK.  
REPAIRING A SPECIALTY.

59 Nassau St., Cor. Maiden Lane, New York.

Royal Arcanum and Maltique Ladies' Enamel Cases

**HERMAN KOHLBUSCH, SR.**

Established 1859  
Manufacturer of  
FINE BALANCES  
AND WEIGHTS for  
every purpose  
where accuracy is  
required. 59 Nassau  
Street, cor.  
Maiden La. N. Y.

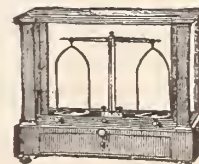

Repairs (any make)  
promptly made.

## THE BICYCLE AS A JEWELER'S SIDE LINE.

**Jewelers' Experiences in the Handling of Bicycles—Sales and Makes of Wheels Handled—Prospects for the Future.**

### PART I.

It has been generally conceded, without much question that the bicycle has become an intimate and profitable adjunct of the jewelry business. It is now the proper time to learn how much positive truth there is in this supposition, and it was with this purpose in view that a letter was addressed to the correspondents of THE CIRCULAR located at various points throughout the United States, embodying the following questions:

*We would like you to send us about 200 words as to the extent to which the jewelers of your city are handling bicycles.*

*The names of the bicycles which the principal jewelers are handling.*

*Some calculation as to the number that are being sold monthly.*

*Prospects for the future in the sales by the jewelers.*

*How long the jewelers expect bicycles to form a part of their stock.*

*Include in your article any other points bearing on the subject that may crop up in your investigations.*

The opinions expressed in the replies received are unbiased, and are dictated by the facts that have come within the range of the correspondents' investigations.

#### Cleveland, O.

CLEVELAND, O., May 12.—At the opening of the present bicycle season it was announced that several Cleveland jewelers would add that business to their regular lines. Up to the present time, however, only one firm has undertaken the handling of wheels, namely Schauweker Bros., wholesale and retail jewelers, Public Square. Joseph Schauweker told the representative of THE CIRCULAR that the business had not proved as satisfactory as had been anticipated.

"There are several reasons for this," said Mr. Schauweker. "In the first place, we have been unable to get the wheels when they were wanted, and while we were waiting for the manufacturer, the purchaser would come in and countermand the order. Then, too, there are all the little vexations and troubles that come to the inexperienced dealer through the even less experienced rider. While we have sold some wheels, we have not made a brilliant success of the business, and do not think the prospects are bright for doing so. To do a successful bicycle business a store must be on the ground floor, which we are not. Then it must have plenty of room for display of wheels and make a sort of loafing place for bicycle cranks. A well equipped repair shop is also a necessity. Now, there are few jewelers who are so situated that they can go into the business in such a manner, and I do not think that many of them will try

it. There is no doubt that the display of wheels by a jeweler brings into the store many people who would otherwise never visit it. Nine out of every ten men who come into the door fix their eyes on the wheels, and their first questions are in regard to them. Some of those who have not purchased bicycles have become interested in jewelry and become profitable customers. What trade we have had has been on high grade wheels, and the inquiry has been limited entirely to that line. We handle the "Elgin" and "Dueber" wheels. We would like to handle bicycles in a jobbing way, but the retail business isn't what it is cracked up to be."

The Webb C. Ball Co. had made arrangements to sell bicycles this Spring, and expected a line of samples wheels several weeks ago, but no wheels have arrived yet, and it is not likely that the Ball Co. will handle them the present season. Last year Sigler Bros. put on the market at their jewelry rooms a high grade wheel and had reasonably good success in handling it, but this year they have put the sale of the wheel in the hands of a regular agency and are having all they can do to turn out the wheels demanded. It seems to be a general belief among local jewelers that the bicycles are too far out of their line to be handled profitably, and they are disinclined to enter it. While the inquiry for bicycles in the city is very great and growing almost hourly, the competition of the bicycle agencies is keeping pace with it and up to the present time they have been fully able to handle all the business that could be worked up. It is estimated that there are 60 local agencies in the city, and fully a dozen factories making bicycles. These agencies represent the largest and best bicycle works in the country and are in the hands of hustlers who are capable of making it exceedingly interesting for all who enter the list of competitors.

#### St. Louis, Mo.

ST. LOUIS, Mo., May 10.—Bicycles are occupying the attention of some jewelers here, and so far three firms have gone into the business to a greater or less extent. Several more are considering the matter. One notable feature, as far as the St. Louis jewelers are concerned, who sell bicycles, is the fact that they all sell high grade wheels, none being offered for sale that are not of the highest order of excellence. This fact will undoubtedly become known to a discriminating public, and they will unquestionably patronize places where the best can be had.

A. Kurtzborn & Sons were perhaps the first jewelry house in the city that went into the business. They obtained the agency of the "Howard" wheel early in January, and think

the bicycle business has come to stay. The wheel they sell is manufactured by the E. Howard Watch & Clock Co., Boston, Mass., and retails at \$100. They sell the wheels as fast as they receive them. Merrick, Walsh & Phelps Jewelry Co. sell the "Rambler," a \$100 high grade wheel. In conversation with Mr. Merrick he told me that henceforth he expected bicycles to form a permanent feature of his stock. In the short time the firm have had them on sale, about a month, a number had been disposed of, and he saw no reason why their patrons should not purchase from them wheels as well as other articles. The latest firm to carry them in stock is the J. Bolland Jewelry Co. Clarence White, secretary of the concern, said they had decided to sell bicycles after mature deliberation. In former years a young man when attaining his majority, or a young lady when graduating, looked forward to receiving a watch or a ring to suitably commemorate the occasion. Now their parents and guardians know what they want in preference to either of these things, namely: a bicycle. Therefore, unless the jewelers were prepared to meet the demand they would lose all this trade, but by putting in a good line of wheels they would not only retain it, but perhaps get a great deal from the outside. The wheels this firm carry in stock are the "Humber," a \$110 wheel, and the "Thistle," a \$100 one. They have had them in stock only two weeks so far, and have sold on an average about one a day. Arnold Zerweck, of Zerweck Bros., says his firm are considering whether or not they should go into the bicycle business. In the Summer trade is dull, but by having a good trade in bicycles the dull season can be made profitable.

M. Eisenstadt Jewelry Co. are the agents in this city of the "Elgin King" and "Queen" bicycles. They sell only at wholesale, and are having a great deal of success in placing them. They are high grade, \$100 wheels, and the firm consider the prospects for jewelers good for this year at least to go into the business.

#### Indianapolis, Ind.

INDIANAPOLIS, Ind., May 13. The bicycle fever has taken a strong hold on Indianapolis with no signs of abatement. There are 10,000 riders in the city, and it is believed that by June 1 the number will be increased to 15,000. Several large factories, including the Indiana Bicycle Co., the largest in the world, and retail stores galore are located here, while bicycles are offered for sale by toy, hardware, dry goods, grocery and jewelry dealers. The jewelers have not gone into the business to any great extent, realizing that they are very much handicapped by the number of manufacturers and exclusive bicycle dealers, who carry large stocks, have every facility for making repairs and exchanges, sell on long and easy terms and maintain riding schools. The jewelers sell largely by catalogue and talk high grade wheels only. Baldwin, Miller & Co. are State agents for the "Elgin" wheels, and have met with fair success, both in the city and State. Among the retail dealers Horace A. Comstock and

Ed. Ducas are the only jewelers who carry any stock. The "Elgin," "Vanguard" and "Thomas" wheels are the principal makes handled, although several others are sold by catalogue. On the whole the bicycle business with the jewelers has not been a success this year, but several of the jewelers have already determined to handle them next year, believing that bicycles have come to stay, and that with this year's experience and with better arrangements, such as the exclusive right to handle certain well advertised wheels, they can make them a paying branch of the business at a season when the jewelry trade is the most quiet.

**Columbus, O.**

COLUMBUS, O., May 12.—The bicycle trade has not entered largely into the jewelry business of this city, wheels being handled by only two firms: W. F. Savage and E. A. Pratt. Mr. Savage carries the "Spalding," "Crenda," and "Columbus" bicycles. The "Columbus" wheel is made by the Columbus Buggy Co., and Mr. Savage is the city agent for it, so that sales are turned over to him which he would not receive in simply representing the other two wheels. His number of sales for the month of April amounted to 45, but the average number for the previous months was only 15. The "Spalding" is his standard wheel but does not sell so readily as the cheaper wheels.

The bicycles kept in stock by Mr. Pratt are the "Thomas" and "Springfield," and his average monthly sale has been eight wheels. He has taken up the sale of bicycles because of the dulness in the jewelry business this Spring, but the venture is of so recent date that neither jeweler is able now to define any future movements by themselves in reference to the wheel trade. They expect a decrease in sales at the close of May and whether their bicycle trade will be detrimental or beneficial to their regular jewelry business they cannot yet tell.

**Rockford, Ill.**

ROCKFORD, Ill., May 13.—At present four of the prominent jewelry houses of this city are handling bicycles; one is in the business for

the first season, the others have been engaged in it for several years. John T. Buker has sold bicycles for six years. He carries a large stock of all grades in which are included three standard wheels, the "United States," "Union" and "Spalding." Al. E. Henry is the agent for the "Columbia," Shumway & Carpenter sell the "Elgin" and J. Beale & Sons the "Union." The future of the jewelers' bicycle business is problematical. They say they were forced into it in a measure, when the druggists and dry goods houses began encroaching upon the jewelry business. Once in, some of them like it. They argue that the jeweler is the proper man to handle bicycles, that he has abundant knowledge of their construction, and is thus a competent

salesman. Competition here is remarkably close, and jewelers are not prepared to say how long wheels will form a part of their stock. They will handle them as long as there is any money in it. The prospects for future sales are not pronounced discouraging. One of the firms above mentioned will take on a number of new makes at an early date. A calculation as to the number sold monthly is not easily made. The jewelers are reticent upon this subject; one of the four firms sold 15 last month, and could have disposed of more had they been securable from the factory.

**Detroit, Mich.**

DETROIT, Mich., May 11.—While none of the Detroit jewelers have as yet taken agencies

# Buy "The Best"

# THE "Dueber Special" BICYCLE.

MAYSVILLE, KY., April 24, 1896.

Dueber Watch Case Mfg. Co., Canton, O.

Dear Sirs: The wheel came all right, and in fact exceeds my expectations. I have ridden the different high grade wheels for twenty years, and find this the easiest running wheel I have ever been on. Yours,

JOHN BALLENGER.

CHICAGO, ILL., April 23, 1896.

Dueber Watch Works, Canton, O.

Gentlemen: After a careful and critical examination of the "Dueber Special" Bicycle, I have no hesitancy in recommending it as a first-class wheel in every respect and I consider it the best wheel I have ever seen. The extreme care bestowed upon the fitting and finish of all parts, will alone recommend it to the watch making fraternity, who as a rule, are critical in these respects. The "Dueber Special" ranks with, if it does not surpass the highest grade wheels on the market. I see no reason why it should not have an enormous sale.

Very respectfully,

GEO. K. HAZLITT.

IT STANDS AT THE HEAD.

THE LIGHT RUNNING

PEERLESS.

THE PERFECT WHEEL.



LIVE JEWELERS

can make money by  
handling our wheels.

Write for terms to Agents.

BEAUTY — STRENGTH — SIMPLICITY.

THE PEERLESS MFG. CO.,  
CLEVELAND, OHIO.

Send Two Cent Stamp for our new Booklet,  
"The Story of the Bicycle."

of bicycles, the representatives of watch manufacturers, who also make a line of bicycles, have been in the city trying to place their agencies in the hands of jewelers. In the country, however, there seems to be a tendency to handle the wheel as a side line. Among those who vend them are: A. W. Kludt, Lennox, Mich.; Eugene Campbell, Pinckney, Mich., and J. S. McLaughlin, Wyandotte, Mich.

**Davenport, Ia.**

DAVENPORT, IA., May 12.—Only two Davenport jewelers have said "yes" to the many agents who have sought to induce the trade to take up the bicycle. M. E. Nabstedt & Sons accepted the agency for the "Unique," manufactured by Johnson, Field & Co., Racine, Wis., and the "Gladiator," made by the Gladiator Cycle Works, Chicago. The house stocked up with eight wheels that it is now closing out at a generous discount, having found that the successful sale of bicycles requires more time

and space than the jeweler can give to it. Conrad Koch, for the same reasons, is not enthusiastic over the bicycle business as an adjunct to the jewelry trade, although he has held the agency, carrying a single sample of the "Banker," made by the Garden City Cycle Co., Chicago. The general opinion in Davenport is that the bicycle, which is each year becoming less and less a luxury, is not an article of jewelry, and more properly belongs in a hardware store.

**Ft. Wayne, Ind.**

FT. WAYNE, Ind., May 14.—There are only a few jewelers in Fort Wayne who handle bicycles, and none of these are pushing business in this line. August Bruder has taken the agency for the "Ducber" wheel. He does not keep it in stock. R. L. Krull, the E. Washington St. jeweler, has been handling the "Warwick" for the past year. He does not expect to engage permanently in this branch of business. His monthly sales average three wheels. F. J. Voiron, the S. Calhoun St. jeweler, has recently taken the agency for the "Keating" bicycle. These are the only jewelers of Ft. Wayne who are interested in wheels in a business way.

**Syracuse, N. Y.**

SYRACUSE, N. Y., May 12.—Your correspondent has been unable to find any Syracuse jewelers who are at present also dealing in bicycles. Of the two jewelers who formerly attempted to handle wheels, one has given his entire attention to bicycles for the last two years, and the other gave up his line of bicycles saying that he could not attend to his jewelry trade and to bicycles also.

**Elmira, N. Y.**

ELMIRA, N. Y., May 14.—Up to present dating the principal jewelers have not entered extensively into the sale of wheels, there now being only three who

have agencies for them. The "Elgin," manufactured by the Elgin Cycle Co., is handled by James T. Wise, as agent. F. S. Ayres carries the "Zenith" bicycle, made in Binghamton, N. Y.; Wm. T. Frost handles the "Acme" wheel. As Messrs. Wise and Ayres have only recently accepted their agencies they could ascertain no estimate as to average monthly sales, Mr. Wise having only sold a half dozen thus far. Mr. Frost reports such a variation in the number of sales that no correct estimate could be made. Future prospects for sales wherein jewelers are interested are not very encouraging, as the output and competition are too large to admit of jewelers making it a paying part of their business. The general opinion among jewelers now handling bicycles seems to favor a discontinuance of sales after the Summer months, as the demand is not sufficient to interest them further. Then, too, wheels are considered more of a detriment rather than a benefit to a stock, not so much from their being undesirable articles, as occupying space which might be utilized more advantageously for goods generally comprising the stock of a jewelry store.

**Worcester, Mass.**

WORCESTER, Mass., May 11.—Worcester jewelers have gone into the handling of bicycles quite extensively, but thus far in the season are getting but a small per cent. of the trade. The exchange of old wheels is a prominent factor in the bicycle trade and the regular dealers are making liberal allowances in this respect, which greatly affects the trade of the jeweler. A. B. F. Kinney handles the largest variety of wheels among the jewelers. He sells the "Wolf-American," which is his high grade wheel, and he also handles the "Silver King" and "Massasoit." He is getting more trade than any other jeweler. He expects to handle wheels next year. W. A. England is agent for the E. Howard & Co. bicycle. He does not expect to handle wheels after this year. J. P. Weixler & Son

**ONE**

Agent wanted in every town to sell the

**STRICTLY HIGH GRADE**



**\$100.00 BICYCLES**

Write for Catalogue and Agents' Terms.

Send 10 Cents for Elgin King Scarf Pin.

Address Department B,  
**ELGIN CYCLE CO.,**  
ELGIN, ILL.



**The Puritan**

...is a...

**Boston Wheel.**

ALSO MAKERS OF

**HECTOR BICYCLES, \$75.**

Factory Established in 1888.

It is High Grade Known as First Class.

WE GRANT AGENCIES ONLY TO JEWELERS. DISCOUNTS AND CATALOGUE ON APPLICATION.

**The F. Kroeber Clock Co., 360 Broadway, New York.**

Sole Agents for the Jewelry Trade.

took the agency for the "Quincy," a \$75 wheel, but being unable to fill orders gave up the agency. The George H. Corbett Co. are handling the "Richmond," made in Richmond, Ind., and are pushing it quite industriously. The firm take old wheels in exchange. Edward Moulton has taken the branch agency of the "L. & W.," manufactured for Lemort & Whitmore, this city. They sell from sample on commission. The bicycle trade among jewelers is an experiment this year. The majority of jewelers do not get sufficient trade to warrant making wheels a feature and it is doubtful if they are seen in jewelry stores another season.

**Connecticut.**

NEW HAVEN, Conn., May 11.—Bicycle selling is now a part of the business of quite a large number of the jewelers of Connecticut and the business is found to be profitable. Jewelers having bicycles to sell say that they make a distinct gain in their profits from the sale of this article of merchandise, not only from the actual sale of bicycles, but because dealing in "bikes" helps their jewelry business, a bicycle customer or visitor often proving to be a purchaser of an article in their regular lines of goods. They say the bicycle, being a bright, showy, and tidy article, does not detract from the appearance of the store and attracts a good class of patrons. Not a few of the leading jewelers have taken a dip into the bicycle business, and they with the others, say that though their sales do not compare with those made by exclusive bicycle dealers, they are "worth the powder." In Hartford C. H. Case & Co. and Henry Kohn & Sons have built special departments for the sale and exhibition of bicycles, the former selling the "New Haven" and "Massasoit," and the latter the "Winton." In New Haven the George H. Ford Co. sell the "Humber" wheel and S. H. Kirby the "Howard," which is sold to jewelers only by the E. Howard Watch & Clock Co. Only a few samples are kept by these firms. In Meriden P. J. Ives and F. Brown deal in bicycles and advertise them well. In Danbury, Rider, Bryant & Co. sell the "Howard" and make quite a specialty of bicycles, and Ryan, Barrows & Parker sell the "Keating" and the "Superb." One of these firms recently gave a very successful public exhibition of their goods at a public hall. In Winsted, Newton & Lincoln advertise extremely the "Charter Oak" bicycle, while jeweler Capewell sells the "Eagle." In New Britain, Burritt & Co. have engaged in the manufacture of the "Burritt" bicycle, and deal also in bicycle sundries, and announce that though beginning the manufacture only about a month ago, they have already sold 35 wheels. In New Britain, M. P. Leghorn sells the "Falcon;" Norwich, H. R. Woodward extensively advertises the "Lindstrom" wheel, and that he is agent for the "Envoy," "Fleetwing," "Elmore" and "Templar" wheels; and H. Rosenthal announces that he has taken the agency for the "Regent." L. G. Massicotte Danielson, largely advertises the "Humber" and the

**Artistic Silver.** ❁ ❁ ❁

Have you seen any more truly artistic or graceful spoon patterns than our "Apollo" and "Lexington," illustrated herewith? They are made in Sterling Silver only and in a full line of all sizes, including cutlery.



TRADE MARK

**J. B. & S. M. KNOWLES CO.,**  
PROVIDENCE, R. I.

Seen on Silver Shows Sterling.



THE APOLLO.

THE LEXINGTON.

**A. WALLACH & CO.,**  
Manufacturers of  
**Gold Chains,**  
11 Maiden Lane,  
NEW YORK.

Adolph Wallach, {  
Antony Wallach, {

This card appeared in the "Jewelers' Circular" of April 15, 1870.

For 50 years Wallach Fine Gold Chains have been recognized as the standard.

We have recently removed to new quarters at

**37 and 39 Maiden Lane,**  
Lorsch Building,  
Room 8.

**A. WALLACH & CO.**

L. ROSENBERGER,  
M. ROSENBERGER.

These well-known Razors, the quality of which is warranted, possess this great advantage, that they may be used for ten years before they require actual sharpening. Before using them, it is necessary to rub them on good leather strop. Lecoultre's Stropps (to be had with the Razors), should be used in preference to others.



THIS CUT IS TWO-THIRDS OF REGULAR SIZE.

**MATHEY BROS., MATHEZ & CO.,**

SEND FOR PRICE LIST      SOLE AGENTS. 21 & 23 Maiden Lane, N. Y.

PAILLARD = = WATCHES

NON-MAGNETIC

ARE AS GOOD AS THE BEST.

R. A. LOVELAND, IMPORTER, 177 Broadway, New York.

"Ames" in a half column space. Optician L. Lyman, Bridgeport, advertises the "Howard." New London, Waterbury and Ansonia jewelers do not seem to have caught the bicycle fever, no evidence thereto appearing in the public prints. The jewelers dealing in bicycles say they have had such encouragement already that they propose to keep on selling bicycles for the present at least.

**Jacksonville, Fla.**

JACKSONVILLE, Fla., May 10.—None of the jewelers here have bicycles for sale. The town is bicycle mad and has about 20 places where bicycles are sold exclusively. It would not pay the jewelers to handle them.

**To Polish Steel.**—If the steel is moderately good temper, use a zinc polisher with diamantine; a tin polisher is better for soft steel. The diamantine should be mixed on glass, using a beater, also of glass, with very little watch oil. Diamantine mixed with oil becomes gummy and quite unfit in a day or two. It also turns black, if brought into contact with metal, when mixing.

**Early Summer Fashions in Jewelry and Silver.**

**A LADY'S RAMBLES AMONG THE JEWELERS.**

To introduce gems into the actual ornamentation of the dress is one of the most artistic ways of using them and has been very generally adopted by the privileged beings who possess them. Others, less fortunate, substitute mock jewels with pleasing effect.

Card cases of rhinoceros skin have either a watch or miniature inserted in one corner.

And now come the fan belts, slender girdles of flexibly connected bits of silver gilt, studded with semi-precious stones. The fan hangs by a slender chain from the belt.

Scent bottles and vinaigrettes of crystal, with tops of silver gilt, are in demand.

Brilliants are mounted as lace pins or have two little eyes by which they can be attached in any given place. The really swagger thing is to fasten numbers of them to the garniture of rich dresses.

Cheese covers of cut glass are positively decorative and beautiful objects.

One of the latest requisites for table decoration is a vase for a single flower. These vases are placed at each corner of the table and are made sometimes of silver, other times of glass, but oftenest of glass and silver combined.

The miniature, which is popular in everything from belts to lockets, has an important place on fans.

Diamonds, emeralds, sapphires and turquoises are much used in the latest hair and hat pins.

Gorgeous chatelaine bags are made in shadow silks with enamel tops, and have fine twisted chain with hook, for securing them to the dress belt.

The newest parasols have slender sticks, mounted with gold or Dresden china handles, in colors to correspond with their changeable silk covers.

ELSIE BEE.

**COMBINATION BELT AND SKIRT SUPPORTER.**

(PATENT APPLIED FOR.)



UTILITY,  
SECURITY,  
SIMPLICITY.

**DEITSCH BROS.,**  
MAKERS,



1 Inch, \$12.00 Doz.  
1 1/4 Inch, \$13.50 Doz.  
1 1/2 Inch, \$15.00 Doz.

**7 East 17th St.,**  
NEW YORK.



### Assignment of the Rockford Watch Co.

ROCKFORD, Ill., May 16.—The Rockford Watch Co. made a voluntary assignment today. Irvin French, a heavy stockholder, was named as assignee. A statement of the condition of the company has not yet been filed. The creditors are mostly local and none is preferred. The last inventory, Dec. 31, showed assets, \$400,000; liabilities, \$110,000. The company hope to effect a reorganization.

A representative of the company stated that the cause of the assignment was the general depression in the watch trade and the consequent lack of demand for watches. He said that on January 1st the assets of the company as inventoried exceeded the liabilities nearly \$300,000. There was at that time a large stock of watches on hand and it was decided to manufacture but few more until the supply was exhausted, consequently but 24 hands were employed at the time of the failure. The reputation of the Rockford watch as a reliable timepiece was depended on to sell the goods but there was no market. Some of the creditors became pressing and in order to protect all a voluntary assignment was decided on Friday evening. The deed was promptly executed and filed.

The company were organized by Rockford capitalists 23 years ago, the capital stock being \$282,000. Levi Rhodes was the moving spirit and first president, and H. P. Holland secretary. There were at one time 400 people employed. During the past few years and

until about the first of the year Mr. Browker was superintendent. H. W. Price is president of the company and G. E. Knight was secretary until a few months ago, when Miss Harriet Beatty was appointed acting secretary, and has performed the duties since. The number of watches in store are not known, although the stock is large.

The stockholders are nearly all residents of Rockford, and it is stated some of them have advanced money to the company at different times, but are secured. None of them will be embarrassed by the assignment. It is now thought the affairs of the company will be wound up, and if watches are again manufactured there it will be under another management.

The Weber Jewelry Co., formerly of Milwaukee, Wis., have moved to Chicago, Ill. O. L. Rosenkrans recently withdrew from the concern.

Thieves Friday night broke into the store of Geo. W. Shellman, optician, Kalamazoo, Mich., and stole all his goods. They left one field glass valued at \$35. The total value of the plunder taken is \$800. The store is located but three doors from where a policeman is stationed all night. Entrance was gained through a skylight, by passing over several buildings. It was undoubtedly the work of men who have operated extensively in the same city. No less than four stores were entered last week.

### The Plan for the New Jobbers' Association.

Elihu Root, who was retained to draw up a plan as a basis for the proposed new association of watch jobbers, finished his work last week and submitted the first draft Friday. If this plan meets with the approval of the merchants who are active in the attempt to organize, a convention of jobbers will be called and the plan submitted to them.

James H. Noyes, who was seen by a CIRCULAR reporter Monday, said that he had received the plan from Mr. Root and had just copied it. He was about to submit it to the committee who have charge of the matter, consisting of N. H. White, of N. H. White & Co., Ira Goddard, and Edward Smith, of Smith & North. Mr. Noyes said he could then give no information about the plan further than to say it provided for an organization on a radically different basis from the old National Association of Jobbers in American Watches. When asked about the membership Mr. Noyes said: "It is not proposed to make any close corporation out of the association or to shut out anyone who is reasonably eligible. The lines of the old association will not define the membership of the new."

A judgment for \$100 has been filed against Morris V. Scott, Indianapolis, Ind., in favor of H. L. Wampler.

Jacob Jasulek, Portland, Ore., has given chattel mortgages aggregating \$4,000 to relatives and other creditors.

# Straus American Cut Glass.

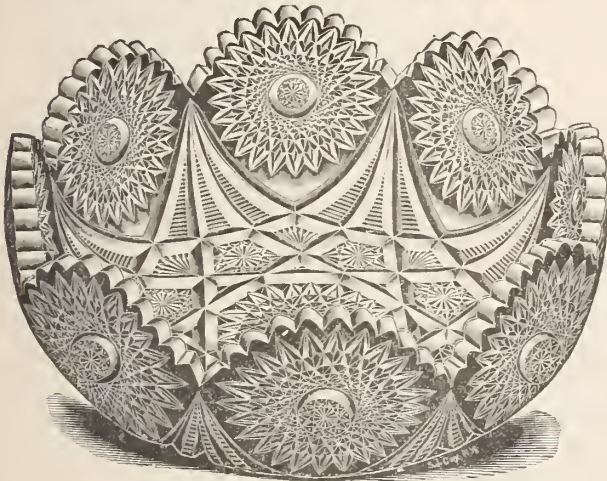

UNIVERSITY.

The "University," one of the new cuttings we produced this Spring, has proved to be a universal seller. It is of the deep cut standard, and contains brilliant and original effects.

LARGE ASSORTMENT OF SHAPES.

Fancy Patterns, But  
No Fancy Prices.

THE STRAUS CUT GLASS IS THE FIRST AND ONLY AMERICAN CUT GLASS USED BY H. I. M., THE CZAR OF RUSSIA, AND GREATLY ADMIRER BY HIS COURT.



FACTORY,  
HOBOKEN, N. J.

## L. STRAUS & SONS,

42, 44, 46 and 48 Warren and 116 Chambers Sts., New York.

**Imports and Exports for March, 1896, and the Preceding Nine Months.**

WASHINGTON, D. C., May 11.—The summary statement of imports and exports for

Jewelry, etc.....	51,005	67,514
Precious stones, etc.....	22,191	19,543

**Exit Olof Turnquest and Wife.**  
SCRANTON, Pa., May 13.—Olof Turnquest, jeweler, 215 Lackawanna Ave., left the city with-

IMPORTS OF MERCHANDISE.

ARTICLES.	MARCH.		NINE MONTHS ENDING MARCH—	
	1895	1896	1895	1896
	Values.	Values.	Values.	Values.
<b>CLOCKS AND WATCHES, AND PARTS OF:</b>	<i>Dollars.</i>	<i>Dollars.</i>	<i>Dollars.</i>	<i>Dollars.</i>
Clocks and parts of.....dut...	31,228	28,871	241,418	439,152
Watches, watch materials, and movements.dut...	76,187	83,875	774,408	873,566
<b>JEWELRY, MANUFACTURES OF GOLD AND SILVER, AND PRECIOUS STONES:</b>				
Diamonds and other precious stones rough or uncut, etc.....free...	8,999	2,555	537,145	83,594
Jewelry, and manuf'r's of gold and silver...dut...	55,257	84,015	451,751	897,259
Precious stones, and imitations of, not set...dut...	442,060	553,872	5,235,147	4,962,397
<b>Imported from—</b>				
United Kingdom.....	3,457	899	375,129	41,178
France.....		16	71,049	1,470
Netherlands.....			49,783	175
Other Europe.....	4,619	1,640	2,877	39,747
Brazil.....	923		10,864	
Other countries.....			413	1,024
Total diamonds, etc.....free..	8,999	2,555	537,145	83,594
United Kingdom.....	132,287	218,075	2,017,171	1,865,044
France.....	84,911	127,141	1,144,321	1,440,562
Germany.....	39,295	40,669	246,973	336,538
Netherlands.....	78,891	91,986	1,614,734	1,088,839
Other Europe.....	161,289	157,957	563,561	1,085,518
British North America.....	90	316	86,247	14,455
Mexico.....	498	1,670	8,540	23,834
East Indies.....			661	297
Other countries.....	56	73	4,690	5,069
Total jewelry, precious stones, etc.....dut..	497,317	637,887	5,686,898	5,860,156

EXPORTS OF DOMESTIC MERCHANDISE.

<b>CLOCKS AND WATCHES:</b>				
Clocks, and parts of.....	70,077	78,669	634,571	655,225
Watches, and parts of.....	38,634	46,799	252,856	381,702
Total.....	108,711	125,468	887,427	1,036,927
Jewelry, and manufactures of gold and silver..	75,203	111,079	530,035	656,646
Plated ware.....	32,315	25,197	260,195	316,915

EXPORTS OF FOREIGN MERCHANDISE.

<b>CLOCKS AND WATCHES, AND PARTS OF:</b>				
Clocks and parts of.....dut...			137	311
Watches, and watch materials, etc.....dut...	19	15	11	7,803
<b>JEWELRY, MANUFACTURES OF GOLD AND SILVER, AND PRECIOUS STONES:</b>				
Jewelry, and manuf'r's of gold and silver...dut...	16,204	260	63,327	35,352
Precious stones, and imitations of, not set...dut..	1,200	6	14,504	2,960

the month ending March 31, 1896, and the nine months ending the same date, compared with the corresponding periods of 1895, has been issued, and contains the above figures relative to the jewelry trade.

The merchandise remaining in warehouse on the last day of March, 1895 and 1896 respectively, was as follows:

	1895	1896
Clocks, etc.....	\$41,834	\$48,674
Watches, etc.....	16,307	33,998

out notifying anyone at a late hour on Friday night. His wife went with him and it is not expected that he will return. He leaves a large number of unpaid bills. Saturday his household goods were attached at the instance of Robert Kiple, the Suburban Electric Light Co. and H. G. Haydn. The statement is made that on Friday, Turnquest sold his jewelry store to John Scoville.

Blaise Tabazac, Los Angeles, Cal., has conveyed realty to the amount of \$3,000.

**First Case Under the Maryland Instalment Debt Law.**

BALTIMORE, Md., May 14.—Judge Dobler reserved his decision to-day in a case which, for the first time since the passage of the law of 1888, raises the question of right of instalment dealers to assign overdue claims. It is unlawful for any person having a claim against a citizen of this State employed by a corporation doing business in other States but subject to the jurisdiction of the courts of this State, to assign such claims.

Henry Matthews, a Baltimore & Ohio Railroad employe, living at Brunswick, Md., bought a gold watch on the instalment plan from the National Jewelry Co. (Jacob and Joseph Castleberg) in 1893, for which he agreed to pay \$80. After paying \$35 he defaulted on his agreement. The claim was assigned by the Castlebergs and Matthews' wages were attached in West Virginia to the amount of \$45 and costs. He asks to recover on the ground that the claim was assigned to evade the Maryland law, and get at him in another State.

**A Suit to Sequester the Goods Shipped away by J. M. Fahrman.**

HOUSTON, Tex., May 15.—The attorneys for Wilson, Eyres & Co., jewelers, have filed suit in the office of the civil district clerk against the Houston & Texas Central Railway Co., to sequester six boxes of jewelry and merchandise, and three boxes of clocks and hardware alleged to have been shipped from Schulenburg, Tex., May 4, by J. M. Fahrman, manager for the jewelry firm, consigned to the L. Bauman Jewelry Co., St. Louis, Mo. Plaintiffs allege that the boxes, with the contents, are each worth \$100; that said merchandise is the property of plaintiffs, and that the delivery to the consignee will be to plaintiffs' great damage. This is the shipment of goods which caused the arrest of Mr. Fahrman as reported in last week's CIRCULAR. Sequestration papers were issued to regain possession of the same goods, the action being directed against the Galveston, Harrisburg & San Antonio railway, with whom the shipment originated, but as the merchandise had passed in the possession of the Houston & Texas Central, a new suit was entered.

**Monthly Production of the American Turquoise Co.**

SANTE FÉ, N. M., May 12.—It is said the turquoise mines near Cerrillos, owned by the American Turquoise Co., have produced turquoise during the past eight months at the rate of \$22,000 a month. This is probably no exaggeration, but the exact figures are difficult to obtain. Superintendent McNulty is not very talkative at any time, and when turquoise is spoken of he is very silent.

C. H. Leggett, Merced, Cal., has filed a petition in bankruptcy.

Phelps & Miller, San Francisco, have compromised at 35 per cent. with eastern creditors.

## Our Traveling Representatives



Traveling representatives may consider these columns open for the publication of any news or items of interest regarding themselves or their confreres.

**M. D. FIELDING,** American Watch Case Co., New York, and E. K. Bennett, Hamilton Watch Co. Lancaster, Pa., were in St. Louis last week. F. Adams, Simpson, Hall, Miller & Co.,

Chicago, and Edward J. Hauch, Wm. Schimper & Co., Hoboken, N. J., were also in town calling on the trade.

Travelers were scarce in Kansas City, Mo., last week, only T. L. Carrow, Mandeville, Carrow & Crane, Lee Hirsch, for Manasseh Levy, and Theo. Wagner, for R. A. Breidenbach being in the city.

S. L. Scott, traveler for M. F. Barger & Co., Chicago, recently taken ill in Cedar Rapids, Ia., has been much benefitted by a stay in Colfax Springs, Ia., and will shortly resume his road duties. R. N. Blair, who has temporarily covered Mr. Scott's territory, has been doing well.

Travelers in Pittsburgh, Pa., last week were: George W. Bleecker, Bassett Jewelry Co.; C. A. Boynton, William B. Kerr & Co.; J. F. Townley, Ripley-Howland Mfg. Co.; Stephen B. Kent, Geo. O. Street & Sons; C. M. Dillon, Meriden Cutlery Co.; Fred. M. Wheeler, Dominick & Haff; Charles S. Isabel, Louis Strasburger's Sons & Co.; Frank W. Trewin, Keystone Watch Case Co.; John A. Davis, Wm. Rogers Mfg. Co.; H. A. Bliss, Krementz & Co.

The following traveling salesmen passed through Detroit last week: Harry Osborne, Howard Sterling Co.; W. R. Shute, Day, Clark & Co.; John Lunn, Snow & Westcott; H. B. Bliss, Gorham Mfg. Co.; A. Kingsland, Reeves & Sillocks; T. H. B. Davis, Middletown Plate Co.; J. E. Simonson, A. J. Hedges & Co.; Chas. F. Ketcham, Riker Bros.; F. Meyer, Goldberg & Meyer; Alfred Varian, Dennison Mfg. Co.; Clarence Pettit, Hayden Mfg. Co.; Geo. R. Angus, Goodnow & Jenks; Mr. Smith, Smith & North; Mr. Gallager, Sinnock & Sherrill, and Mr. Cobb, W. R. Cobb & Co.

Travelers visiting the Hub during the week included: H. F. Barrows, H. F. Barrows & Co.; T. G. Frothingham; Herbert Barker, J. W. Reddall & Co.; T. B. Wilcox, Jr., Pairpoint Mfg. Co.; H. W. Dunham, Meriden Silver Plate Co.; Benjamin Griscom, Bippart & Co.; George Read, William B. Kerr & Co.; E. L. Spencer; Mr. Ripley, Watson, Newell Co.; Mr. Smith, Marble, Smith & Forrester; Fred Clarkson, Snow & Westcott; Henry Ide, H. C. Hardy & Co.; C. Peckham, E. Aug. Neresheimer & Co.; Leverett S. Lewis, Randel, Baremore & Billings; F. J. Keller, Keller Mfg. Co.

Traveling salesmen calling on the Louisville, Ky., jewelers last week were: Robert Welch, Welch & Miller; M. Tinker, for Wm. B. Durgin; L. Hirsch, for Manasseh Levy; Wm. Smith, Kent & Stanley Co. Ltd.; F. C. Allen, for A. Wittnauer; H. S. Dinkenspiel, Koch, Dreyfus & Co.; J. B. Ettinger, Keller, Ettinger & Fink; S. K. Jones, Levy, Dreyfus & Co.; Coleman E. Adler, Byron L. Strasburger & Co.; W. Royal Berth, Gorham Mfg. Co.; H. B. Beckett, Dennison Mfg. Co.; W. H. Bryant, T. G. Hawkes & Co.; W. H. Boice, Krause, Boice & Co.; S. W. Abbey, E. Ira Richards Co.; W. A. Moore, for F. W. Gesswein Est.; John W. Case, H. F. Carpenter & Co; Mr. Brooks, Brooks & Pike; I. W. Friedman; and Lewis Ranch, Stern & Co.

Travelers in the jewelry line visiting Syracuse, N. Y., the past week included: Mr. Pierce, Harrison Bros. & Howson; Mr. Thompson, Sinnock & Sherrill; H. H. Bradley, E. A. Bliss Co.; F. D. Smith, Bippart & Co.; Mr. Terrill, E. Ira Richards & Co.; Otto H. Wolff, Alling & Co.; J. W. McClannin, Kent & Stanley Co. Ltd.; A. Kingsland, Reeves & Sillocks; Anson D. Manning, D. Wilcox & Co.; Jas. S. Beatty, S. B. Champlin Co.; F. C. Standinger, E. A. Lehmann & Co.; Mr. Kenrick, Reed & Barton; R. T. Supple, for William B. Durgin; B. A. Marsden, for D. V. Brown; Bradford H. Knapp; J. Goldberg; Abe Harris, R. L. & M. Friedlander; H. C. Barnum, Shafer & Douglas; C. F. Goodwin; Mr. Durlach, Durlach Bros.; Col. John Shepherd, Keystone Watch Case Co.; Charles Rosenbaum; W. J. Carrow, Mandeville, Carrow & Crane.

In a fire in Altoona, Pa., Friday morning, the store of W. H. Kelly, pawnbroker and jeweler, was affected.

## Pennsylvania Jewelers Discuss the Department Store Evil.

PHILADELPHIA, Pa., May 16.—Having secured comfortable and convenient new quarters at Elk's Hall, 223 N. 9th St., the Pennsylvania Retail Jewelers' Association held their first regular meeting there, May 13, two sessions of the organization occurring on that date. Until recently the Association have occupied apartments at 36 N. 9th St., and the transfer to a new place of meeting being made under favorable conditions the Wednesday sessions assumed the nature of special conclaves.

At the afternoon session the formal opening of the new headquarters took place. President I. Hertzberg was in the chair at both sessions, and Charles H. Hamer occupied his usual position as secretary. Among the others present were: S. C. Levy, J. R. Hamer,



BATES & BACON  
"FAVORITE"  
14K

### ALWAYS

Ask to see  
our



BATES & BACON  
"ROYAL"  
14K

GOLD FILLED  
WATCH CASES.



BATES & BACON  
"PURITAN"  
14K

None Better  
and  
Few Equal.

The Only Real

# UNIVERSAL

## Spectacle and Eye Glass Case.



**O**NE great advantage of this case is that one wearing a spectacle and eye glass (or two pairs of spectacles, or two pairs of eye glasses) can be perfectly accommodated with one case—the UNIVERSAL.

SEND \$1.50.

## H. E. Kirstein & Co.,

Rochester, N. Y.

C. Courad, G. M. D. Lewis, S. Leusch, C. B. Lynch, John Tausley, E. H. Williams, J. P. Jeurislee, H. Canfield, S. L. Schumo, E. J. Dougherty, and J. W. Smith.

The principal topic of discussion at both meetings was the department store evil and its influence upon the jewelry trade. It seemed to be the sense of the meetings that without organization there could be no benefits derived from a struggle against the department store. With the trade united in a vigorous crusade against the objectionable features, wonderful results could be attained.

A number of the members at the evening session expressed the belief that by strengthening the organization until it has assumed powerful dimensions, the trade would be benefited to an enormous extent, whenever it became necessary to deal with troublesome problems.

### Last Week's Arrivals.

The following out-of-town dealers were registered in New York during the past week: L. Bauman, St. Louis, Mo., Hoffman H.; Jos. Linz, Dallas, Tex.; J. W. Podmore, Troy, N. Y., Astor H.; A. E. Newhall, Lynn, Mass., Broadway Central H.; A. A. Abbott, Montreal, Can., Ashland H.; A. G. Paul, Boston, Mass., Marlborough H.; G. Greenzweig, San Francisco, Cal., Astor House; M. Eliassof, Albany, N. Y., Union Sq. H.; A. L. Sercomb, Chicago, Ill., St. Denis H.; J. H. Hosley, Springfield, Mass., Park Ave. H.; H. W. Askenasy, Boston, Mass., Imperial H.

### Annual Meeting of the Iowa Retail Jewelers' Association.

DES MOINES, Ia., May 14.—The fifth annual convention of the Retail Jewelers' Association of Iowa opened in the club rooms at the Savery, Tuesday evening. There were not to exceed a dozen members present and no one was there to represent the Des Moines jewelers. The meeting was held behind closed doors and the officials were rather reticent about what was being done. They denied that an effort is being made to establish a uniform system of charges for repairs, etc., in the State and insisted the organization is simply for the interchange of ideas as to the best means to use to make the business successful. It was stated the merits of various kinds of watches, etc., would be discussed during the meeting, that plans for the protection of jewelers from burglars would be talked over and the credit system considered.

Yesterday, the second day of the meeting, the following officers were elected: President, E. G. Bowyer, Algona; vice-president, D. A. Curtis, Knoxville; secretary, H. Kirkpatrick, Battle Creek; treasurer, T. L. Rogg, Des Moines; directors, M. Wollman, Council Bluff, H. H. Teig, Lake City, O. G. Shaw, Monroe; delegates to the National Retail Jewelers' Convention in Atlantic City, N. J. in July, T. L. Rogg, Des Moines, and Solomon Joseph, Des Moines.

The next annual meeting will be held in Marshalltown, in May, 1897.

### Trans-Atlantic Voyagers.

#### FROM EUROPE.

Julius Eichenberg, Providence, R. I., and Leopold Levy, of Levy Bros. Co., Hamilton, Ont., returned last week on the *Havel*.

Frank H. LaPierre, New York, returned last week on the *Teutonic*.

John C. Mount, of Randel, Baremore Billings, New York, J. B. Bowden, of J. B. Bowden & Co., New York, R. J. Mount and, W. N. Walker, of H. W. Wheeler & Co., New York, returned last week on the *Campania*.

Read Benedict, of Benedict Bros., New York, Mrs. H. H. Benedict, Miss Helen Benedict, Paul M. Benedict, New York, and J. Bertram Lippencott, Philadelphia, Pa., returned on the *St. Paul*.

#### TO EUROPE.

Mr. and Mrs. J. Albert Caldwell and Master J. E. Caldwell, Philadelphia, Pa., and Jos. Zilver, of Zilver Bros., Brooklyn, N. Y., sailed Wednesday on the *Paris*.

Moritz Falkenau, of Falkenau, Oppenheimer & Co., New York, accompanied by his wife, sailed May 12 on the *Lahn*.

Adolph J. Grinberg, of A. J. Grinberg & Co., New York, J. G. Cottier, of C. Cottier & Son, New York, Geo. A. Glaenger, Chicago, and Jos. Schweizer, of the Ansonia Clock Co., New York, sailed on *La Touraine*, Saturday.

J. Eugene Robert, accompanied by his family and E. E. Robert, New York, will sail on the *Werra* for Genoa, May 23d.

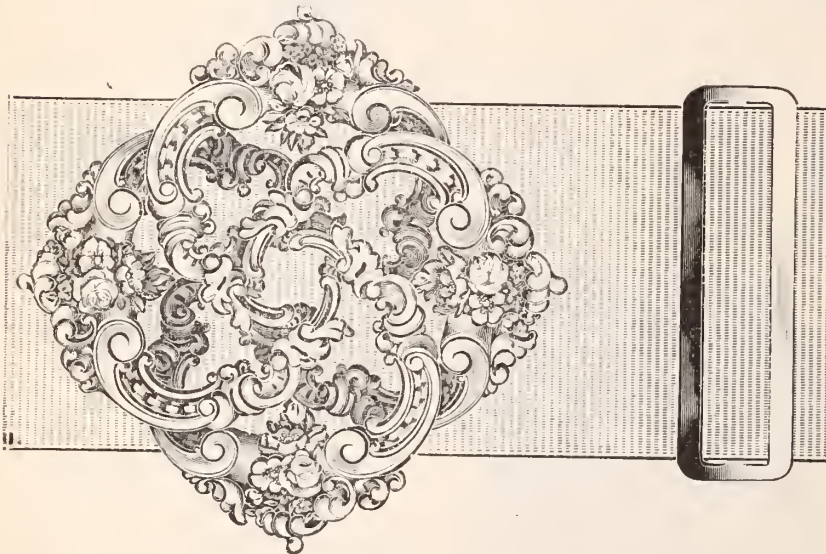

FRONT VIEW.

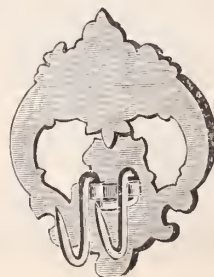

BACK VIEW.

No. 8466 PLAIN SILVER.

“ 8467 OXIDIZED.

“ 8468 OLD GOLD FINISH.

“ 8469 SILVER GILT.

“ 8470 SILVER GILT ENAMEL.

“ 8471 SILVER ENAMEL.

## BIPPART & CO.,

Manufacturing  
Jewelers,

NEWARK, N. J.

## Lorraine Belt Retainer

PATENT APPLIED FOR.

Made in great variety in 14k. Gold and Sterling Silver.

It is the simplest and most practical Belt Retainer in the market.

**The Watch Companies' Suit Over the Colby Pendant Patent.**

CINCINNATI, O., May 13.—Judge Taft, Judge Purton and Judge Hammond, occupied the bench at the opening of the United States Circuit Court of Appeals, yesterday. Judge Taft gave the decision of the Court in two cases. The first was the Dueber Watch Case Manufacturing Co. (John C. Dueber, president, and Winthrop A. Moore, secretary and Treasurer) vs. Royal E. Robbins and Thomas M. Avery, trustees.

This was an appeal from a decree enjoining the infringement of a patent. The complainants below, Royal E. Robbins and Thomas M. Avery, as trustees for the American Waltham and Elgin National Watch Companies, held title to the patent issued to Caleb Colby for the stem and stem arbor of a watch, arranged with a latch spring inside of the stem to secure the key or stem arbor in one or two positions, from which it could not be moved to the other without special effort. The Circuit Court of the Northern District of Ohio sustained the validity of the Colby patent, and held that the defendants, the Dueber Watch Case Mfg. Co., were infringing the same.

The Circuit Court of Appeals, in an opinion by Judge Taft, differed from the Circuit Court, and held: First, that the Colby patent, in view of the prior state of the art, was void, for want of novelty; and second, that even if it was not void, the scope of the patent was so narrow that the device which the Dueber Watch Case Mfg. Co. used was not an

infringement of it. Decree reversed, with the costs, with directions to dismiss the bill.

INTERVIEW WITH ROYAL E. ROBBINS.

BOSTON, Mass., May 16.—Apropos of the decision of the United States Circuit Court of Appeals in the case involving the validity of the Colby patent on the pendant settings for watches, Mr. Robbins, of the American Waltham Watch Co., said in an interview:

"The patents to which the decision refers were patents on the pendant setting feature of watch cases, and had no reference to the watch movement pendant setting patents controlled by the Waltham and Elgin companies, which latter have long since been established and finally confirmed. As neither the Waltham nor the Elgin company manufactures cases, the decision neither affects the manufacturing at either factory nor their sole control of the pendant setting movement. The suggestion that the Dueber Company may have a claim for the refunding of royalties is absurd, since a patent is good until declared invalid."

Assignment of the Thayer Jewelry Co.

MEMPHIS, Tenn., May 15.—The Thayer Jewelry Co. have assigned for the benefit of creditors to H. Caro, as trustee. The instrument conveys all the stock of jewelry in the store on the southwest corner of Main and Court Sts., and also a lot of jewelry which was attached under writs of attachment issued from the Chancery Court, of Shelby county, on Dec. 24, 1895, in the suits of Champenois

& Co. and H. Keck Mfg. Co. vs. V. B. Thayer et al., which suits are pending in the Chancery Court.

The trustee is to administer the property. A schedule of liabilities filed with the assignment amounts to \$3,643.35. The creditors are almost entirely foreign parties.

The Effects in the East of Newwitter & Rosenheim's Failure.

PROVIDENCE, R. I., May 15.—Quite a little stir has been occasioned among the manufacturing jewelry concerns of this city and the Attleboros upon the receipt of the intelligence that the affairs of Newwitter & Rosenheim, of New York, were in the hands of a receiver. The concern had enjoyed the confidence of the manufacturers and were able to obtain an almost unlimited credit. For some months past, however, it has been evident to many that there was something wrong in the internal workings of the concern and several firms had reduced their credit to a considerable extent. As it is the amount of liabilities held by the eastern manufacturers is very large, probably approximating \$75,000.

It is stated that one concern in Attleboro holds about \$6,500, and that several have claims for from \$500 to \$1,000. There are some firms, both here and in Attleboro, caught in the disaster that can ill afford to lose their claims, as business with some of them has not been over productive of prosperity the past year and the prospects for the immediate future do not appear very bright.

**THE MOST POPULAR BUCKLE**

—♦ IN THE MARKET. ♦—

All Belts  
Interchangeable.

Our Belt Hook

is the only perfect arrangement for holding the skirt under Leather Belts.

PLAIN OR FANCY.

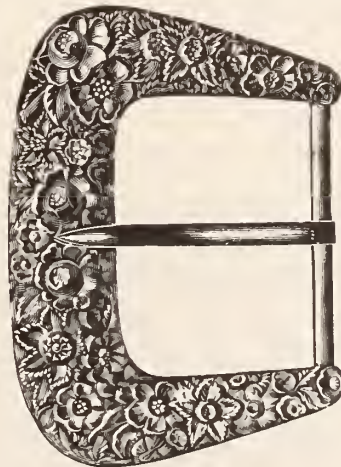

NO. 3911/1.

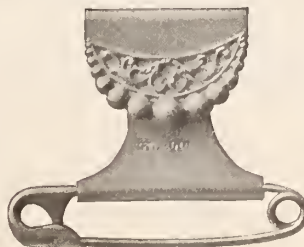

NO. 3840.

MOUNTED ON FINEST LEATHER BELTS, ALL COLORS.

BAGS TO MATCH.

SIMONS, BRO. & CO.,

SILVERSMITHS AND MANUFACTURING JEWELERS,

PHILADELPHIA,

NEW YORK,

CHICAGO.

**Condition of Affairs of Clement H. Davison.**

The full report of the committee of creditors of Clement H. Davison, Washington, D. C., appointed at the creditors' meeting in New York, March 23d, to go to Washington and investigate the affairs, was completed last week and is published below for the first time. The committee consisted of Ludwig Nissen, chairman, Jno. L. Taylor, of Kremenetz & Co., J. H. Le Croix, of the Waterbury Watch Co., F. H. Larter, of Larter, Elcox & Co. and F. Geiger, of Hoyt, Geiger & Co. A brief report of their work was published in THE CIRCULAR, April 1st. Their full report is as follows:

*Mr. Ludwig Nissen and Gentlemen:*—Complying with the request of your Committee, I have made an examination into the affairs of Mr. C. A. Davison, as shown by books and papers placed at the disposal of your committee by the assignee.

I find that prior to July 8, 1895, Mr. Davison had not made the least pretensions to keep any account or books of record of his business affairs, with the exception of check book stubs and a few unimportant memorandums, there does not appear to be any books whereby a satisfactory explanation of his condition financially might be obtained. Therefore the information derived must date from July 8, 1895. From this date, to the day of his assignment, an effort has been made to properly record his purchases and sales and to keep his affairs in a more systematic manner. The books were fully posted to March 7, 1896, and excepting the failure to account for several invoices a reasonably fair account of the situation, as presented by his books, was obtainable.

On July 8, 1895 the books were opened with the following statement showing Assets and Liabilities, viz:—

Cash in Bank (Verified by bank book)	\$746 12
Furniture, as he appraised it	375.00
Bills receivable	75.00
Cash in drawer	26.97
Bad accounts	195.00
Good	1,106 29
Merchandise Goods in store	25,000.00
<b>Total Assets,</b>	<b>\$27,524.29</b>

The stock of merchandise, as above stated, was merely (as Mr. Davison states) "a guess"; he does not claim to have taken any account of same, on hand but judged that the above mentioned figures was "about right." There was not any means to verify his assumption.

<b>Liabilities were</b>	
Bills Payable	\$3,782.20
Open Accts	20,166 94
<b>Total</b>	<b>\$23,949.14</b>

Leaving an apparent surplus in the business of \$3,575.15

His books show a total amount of purchases from July 8, 1895, to March 8, 1896, of \$52,509.76

But in view of many discrepancies in accounts of creditors as shown by statements rendered to the assignee and as shown by amounts credited on his books I should judge that from \$1,000 to \$1,500 might be added to the above. All parties interested have not as yet filed their claims with the assignee.

*Sales.*—The total amount of sales shown, including gross charges from July 8, 1895, to March 10, 1896, is \$40,657.64.

This amount is substantially verified by his deposits, which were regularly made. His and book and the several charges of the above sales.

November, 1895, was	\$3,685 46
December, 1895 was	15 549 78
<b>Total</b>	<b>\$19,235 24</b>

or nearly 40 per cent. of the entire 8 months' sales were during these two months.

*Expenses.*—The total expense account for the above mentioned period was shown to be \$5,209.70. Included in this amount is \$988.00 for advertising salaries, and also an amount of \$15.00 per week drawn by Mr. Davison for 28 weeks of the period. After this period the \$15.00 per week was charged regularly to his private account.

*Horse and Carriage Account.*—On July 19, 1895, he purchased a carriage and harness, paying for same \$200.00, which bill he claims was made out to his wife and which he intended to present to her for services. September 24, 1895, he purchased a horse for \$100.00. November 11, 1895, he purchased "trap" for \$80.00, and on same date a "wagon" for \$60.00—making a total horse, carriage and harness account of \$440.00. It might be well to state here that this entire account appears on the books as an asset. The claim of Mrs. Davison to any part of the above is not shown.

*Private Account.*—This represents the amount charged to Mr. Davison for the period mentioned, included in this is the few weeks' salary at \$15.00 not charged in expense account, doctor bills and various small items, a total of \$1,764.99.

His account is also credited with \$226.99 being for sales and profits on sale of transactions, not coming directly out of his stock.

*Pay Roll.* The pay roll presents a general average about as follows:

Miss Bond	\$8.00	per week.
Miss Clear	5 00	"
Miss McBride	5 00	"
Miss Clark	5 00	"
Watchmaker	18 00	"
Engraver	12 00	"
Jeweler	10 00	"
C. H. Davison	15 00	"
1 Porter	6 00	"

During 6 or 8 weeks of the holidays, he employed two ladies at \$5.00 per week each and an extra porter at \$5.00 per week.

*Rent Account.* He has a leasehold on store and fixtures by which he has paid for 9 months \$1,837.53 or at the rate of \$204.17 per month. From this it will be proper to deduct as shown, rents collected for the upper part of building of \$576.23, making his actual rental account \$1,261.30.

*Interest.* He has paid interest on loans and on notes given for purchase \$224.38.

This account represents the amount of special discount he was enabled to obtain from prompt payment of invoices viz: \$1,026.35. This account is charged with \$1,420.00.

*Furniture and Fixtures.* But there is in this included a purchase for a safe of \$800.00 on the rental or installment plan, and on which he has paid \$300.00. The account, therefore, is falsely stated by at least \$500.00—the other items are for small show case, chairs and sundry small items. The actual value of his rights and interests in this account, taken as an asset, must, therefore, be considerably reduced.

These accounts cover all accounts, that are not either a customer or a creditor and from them we can produce a summary of his affairs, taking in consideration of course, the profit on sales, that he claims to have placed on his goods when selling prices were marked.

He began July 8, 1895, with an estimated stock of \$25,000.00

He purchased as shown by books 52,509 76

Added to this for invoices lost or when statements are not in comparison with his books—

an estimate of 1,200.00

Total 78,709.76

Sales were from July 8th, 1895 40,657 64

He estimates his profits at 33 1/2 per cent. over and above his cost of merchandise, or a gross profit of 25 per cent on the above amount of sales.

Which would give a gross profit \$10,164.41

This amount would bring the cost value of merchandise sold 30,493.23

Which deducted from stock and purchases above would leave a balance of 48,216.53

This figure should represent very closely the amount of stock, etc., that he should have had in store on the date of his assignment, provided, of course, that his above estimate of profit was generally received.

Deduct the following as shown by expense account \$5,209.70

Interest account 224 38

Furniture and Fixtures 1,420.00

Horse and carriage account 440.00

Balance of private account 1,097.97

Total \$8,392.05

Less rents received \$576.23

Less discounts made 1,026.35

Total \$1,602.58—\$1,602.58

Balance is net expenses for running business \$6,789 47

Which amount deducted from above assumed gross profits \$10,164.41

Would make his business appear to show a net profit of \$3,374.94

Mr. Davison now states that the above estimate of presentment of profits was not "always" received and the result of stock taking clearly proves that his estimate was far from correct. He acknowledges that during November 1895, as an extra inducement for trade he took 10 per cent. off his regular market prices on all sales, and again in February, 1896, he made a reduction of 15 per cent. His object in so doing was to raise funds to meet his many maturing obligations.

The result of stock taking show that on March 27, 1896, he had on hand \$32,684 44

Cash in hands of assignee derived from sales from March 10th to March 27th 2,094.00

Total \$35,778 44

If his statement of profits as before estimated were any where near the facts as shown; the deficiency in stock or un-accounted for loss would be \$12,438 09, to this must be added an apparent surplus of July 8, 1895—\$3,575.15—making a total loss unaccounted for of \$16,013 24.

Annexed is a copy of his cash book showing by monthly detail all his cash deposits and receipts, also his disbursements not including "Petty Cash."

July, 1895, Receipts \$3,782.85 Disbursements \$3,729 76

Aug. " " 2,231.51 " 2,189 42

Sept. " " 2,458.11 " 2,562 96

Oct. " " 5,929.59 " 5,930 30

Nov. " " 3,817.96 " 3,587 26

Dec. " " 12,741 30 " 12,368 39

Jan. 1896, " 3,873.08 " 4,063 32

Feb. " " 4,883.98 " 4,812 64

Mar. 1st & Mar. 16th 1,513.38 " 1,671 42

\$41,231.76 \$40,909.47

By comparing above it will be seen that at the first of any month he did not have any very large bank balance. Something over \$300 being the largest monthly balance shown, and these facts are corroborated by his check books which show almost invariably checks drawn on same day as deposit or obligations paid, that would about cover all of such deposit.

His deposits for the period in question were in Traders Bank of Washington \$4,682.25 Columbia Bank of Washington 34,419.90

Total \$39,102.15

This amount is remarkably close to his sales and collections, and in a measure prove their accuracy.

*Assets Accounts Due.* There is an apparent resource on the books of \$3,478.46 accounts due him. This should be materially reduced by deducting various accounts that are "offsets" to claims against Mr. Davison. They are as follows:

Advertising account \$322 00

" " 980 50

" " 203 75

Total \$1,511 25

There is some dispute about the claims against him, to which these accounts are "offsets," but, in all probability, they will be allowed, then add to this acknowledged accounts that are worthless, \$715.20; will leave an actual available book assets of \$1,252 01.

*Liabilities.* As before stated, in consequence of delays in forwarding claims to the assignee in full statement form, the actual liabilities could not be ascertained at this time. Sufficient facts, however, were at hand to make a very close approximation.

There are open accounts \$21,206 26

Notes and bills payable 24,076 75

Accounts not posted in books 1,493 00

Total \$46,776 04

It is believed that this amount will be the maximum amount of liabilities, when full settlement is made. In this amount (\$46,776.04) the entire bills of advertising, etc., are allowed, and no "offsets" are deducted. The present situation of the business, as thus presented at this date, March 27, 1896, is about as follows:

Stock of merchandise on hand as per stock taking of committee \$32,684 44

Cash in hands of assignee 2,094 00

Good and available accounts 1,252 01

Furniture and fixtures estimated 150 00

Horse, carriage and harness 100 00

Total assets \$36,280 45

Liabilities \$46,776 04

Less offsets 1,511 25

Total \$45,264 79 45,264 79

An actual deficiency of \$8,984.34

I believe all figures and calculations as herein expressed substantially correct, but slight inaccuracies may present themselves, in which case the unsettled state of the books, shortness of time given me, and missing vouchers may be offered as an excuse.

Yours, FRED C. GEIGER.

The statement of the assignee, Henry F. Woodward, of C. H. Davison, is as follows:

This assignee charges himself with having received:

March, 1896

10-11 sales \$204 40

13 " 261 14

14 " 211 09

16 " 113 92

17 " 302 64

18 " 264 64

19 " 164 58

20 " 257 63

21 " 213 43

23 " 116 33

24 " 208 16

25 " 160 89

26 " 57 95

Total \$2,536 82

March, 1896

13 collections 23 15

14 " 12 50

16 " 33 25

17 " 37 25

18 " 5 00

19 " 9 50

20 " 9 50

23 " 4 50

24 " 1 00

Apr. 16 " 110 05 245 70

Sale of accounts to S. W. Woodward 500 00

Sale of stock to Robert Leding 16,500 00

Sale of horse and wagon 100 00

Sale of fixtures 50 00

Total \$19,932 52

Assignee credits himself with,

Commission to assignee \$1,993 25

Pay roll 516 60

Rent 387 94

Exemption 200 00

Gas and E. light 75 58

Advertising 78 90

Livery bill 49 25

Sundry expenses 224 55

26 per cent. dividend paid creditors on total indebtedness on \$46,268 61 16,656 70

Total \$19,982 77

Overdraft paid by assignee 50 25

Total \$19,932 52

# The Jewelers' Circular

AND  
HOROLOGICAL REVIEW.

PUBLISHED EVERY WEDNESDAY BY  
**THE JEWELERS' CIRCULAR PUB'G CO.,**  
189 BROADWAY, NEW YORK CITY.

A JOURNAL DEVOTED TO THE INTERESTS OF JEWELERS, WATCHMAKERS, SILVERSMITHS, ELECTRO-PLATE MANUFACTURERS, AND ALL ENGAGED IN KINDRED BRANCHES OF INDUSTRY.

Member of the American Trade Press Association.

Our Editorial columns will contain our own opinions only, and we shall present in other columns only what we consider of interest or value to our readers. Advertising matter will not be printed as news.

Advertising rates in THE CIRCULAR are lower, considering the number of tradesmen reached by its large circulation, than in any other jewelry journal.

Notices of changes in standing advertisements must be received one week in advance; new matter can be received up to Monday.

## INFORMATION FOR SUBSCRIBERS.

### Terms of Subscription, Postage Prepaid.

	PER ANNUM.
United States and Canada, - - -	\$2.00
Foreign Countries in Postal Union, - - -	4.00
Single Copies, - - - - -	.10

New Subscribers can commence at any time.

Payments for THE CIRCULAR when sent by mail, should be made in a Post-Office Money Order, Bank Check or Draft, or an Express Money Order or Registered Letter. All postmasters are required to register letters whenever requested to do so.

Pay money only to authorized collectors having proper credentials.

**Returning Copies** Returning your paper will not enable us to discontinue it, as we cannot find your name on our books unless your address is given.

**Changing Address.** In changing address always give the old as well as the new one. Your name cannot be found on our books unless this is done.

**Discontinuances.** We will continue to send papers until there is a specific order to stop, in connection with which all arrearages must be paid; but such an order can be given at any time, to take effect at or after the expiration of the subscription. All such orders will be promptly acknowledged by mail.

**Liability.** The Courts have decided that all subscribers to Journals are responsible until arrearages are paid in full and an order to discontinue has been received by the publisher.

## THE JEWELERS' CIRCULAR IN EUROPE.

Among the Places in Europe where THE JEWELERS' CIRCULAR is on file are the following:

**LONDON**—First Ave. Hotel, Holborn. E. C.; Holborn Viaduct Hotel, Royal Hotel.

**PARIS**—Hotel de L'Athénée, Rue Scribe.

**BERLIN**—Deutsche Uhrmacher Zeitung, Jäger-Strasse, 73.

**GENEVA**—Journal Suisse D'Horlogerie.

**AMSTERDAM**—Continental Club, Hotel Amstel.

**ANTWERP**—Diamond Club, Rue de Pelican.

Vol. XXXII. May 20, 1896. No. 16.

Every line of reading matter in THE JEWELERS' CIRCULAR, with the exception of the few brief extracts from exchanges, always properly credited, is written exclusively for this journal. Each issue of THE JEWELERS' CIRCULAR is copyrighted. Permission to quote is extended to other publications, if such quotations are properly credited.

## The Handling of Bicycles by Jewelers.

If we will analyze a so-called general idea or impression, we will often find that it is founded upon insufficient facts in the premises; a belief spreads with the rapidity of an infectious disease, the mind of the individual unconsciously accepting what others believe without inquiry or investigation. For some time past it has been generally believed in the trade that the omnipresent bicycle has become an intimate and profitable element of a jeweler's stock. We have ourselves been inclined to accept this belief, but it is now an opportune time to enter upon an inquiry into the matter, to learn how intimate is the relation between bicycles and jewelry and how profitable is the bicycle as a line of jeweler's merchandise. A letter containing pertinent and searching questions was sent to all of THE CIRCULAR's correspondents located in scattered large cities throughout the Union. The replies received represent the pulse of opinion of perhaps over 1,000 members of the trade. In this number of THE CIRCULAR the first instalment of the correspondents' replies is published; but until all the replies are presented to our readers, we will retain our deductions from them. We will suggest, however, that those jewelers who would estimate the profits accruing from the handling of wheels, take into their calculations the amount of energy expended in conducting this branch of a jeweler's business, the resulting loss of energy expended on his established lines, and the effects, beneficial or deleterious, produced in one business store by the juxtaposition of bicycles and articles of scientific achievement as watches and clocks, and artistic character as jewelry, silverware and bric-à-brac. It must be remembered in making calculations as to profit, that there may be ultimate loss to a jewelry business in bringing it, by reason of the inclusion in it of lines not altogether germane to the established lines, too close in character to those other businesses in which such foreign lines are recognized, without question, as being entirely in harmony with the remaining stocks.

## Analysis of Diamond Import Figures.

THE exposition of import figures bearing upon the jewelry trade, published in these columns from month to month, is not reassuring. The greatly decreased volume of imports of diamonds and precious stones cannot be gratifying either to those who believe that home industries should be fostered by a high tariff or those who believe that a tariff should be enforced for revenue only. The array of beggarly figures that represent the imports of these articles during March, 1896, does not carry out the calculations of Congressmen Holman and Springer who saw in the increased tariff on precious stones an increased revenue for the government. This array is as follows:

March, 1896.

Diamonds and other precious stones, rough or uncut, etc., [free].....	\$2,555
---	---------

Precious stones and imitations, if not set [10 per cent. or 25 per cent.] .....	\$555,872
---	-----------

This exposition is slightly better than 1895, as far as the second item is concerned, March, 1895, showing only \$442,060; but the first item shows a great falling off from even the scanty figures of 1895, which were \$8,999. How the revised tariff has affected the diamond importing industry may be seen in a comparison between the foregoing figures and those of March, 1893, which are as follows:

Mar. h, 1893.

Diamonds and other precious stones, rough and uncut [free].....	\$120,849
Precious stones and imitation, if not set [10 per cent.].....	\$1,534,913

A certain amount, not specified in the Treasury monthly statistics, in the second item of the first table, represent the imports of rough precious stones for cutting (10 per cent.), but even if the entire amount, \$558,872, was assessed at 25 per cent., the revenue to the government would be only \$138,968 against \$153,491 in 1893, when the assessment was only 10 per cent. Undoubtedly the revenue for March, 1896, does not amount to \$120,000, the government getting \$30,000 less than in the same month of 1893. It does not follow from the foregoing analysis that the quantity of precious stones brought into the United States in March, 1896, was greatly less than that brought in in March, 1893. Undoubtedly the difference in the condition of general business at the two dates may warrant the supposition that a less quantity was brought in in the former than in the latter month; but we do not believe that it was two thirds less as shown. A large part of the discrepancies may be attributed to the operations of the ubiquitous smugglers.

## The Diamond Tariff Test Case Settled.

WASHINGTON, D. C., May 18.—The Supreme Court to-day handed down a decision which settles the diamond tariff by denying the application to bring the test case instituted by Jos. Frankel's Sons before it for review. The application for a writ of certiorari to review the judgment of the United States Circuit Court of Appeals sustaining the duty of 25 per cent. on diamonds, was made to the United States Supreme Court two weeks ago, as told in THE CIRCULAR at that time. The refusal of the Supreme Court to bring the case before it makes the decision of the Circuit Court of Appeals final, and diamonds must be assessed at 25 per centum.

At the office of Curie, Smith & Mackie, counsel for Jos. Frankel's Sons, a CIRCULAR reporter verified the news that the application for the writ of certiorari was denied and was told that this step settled the case.

## Death of Salesman Earl L. Richards.

ATTLEBORO, Mass., May 13.—Earl L. Richards, one of the oldest jewelry salesmen in the country, died at his home on Pech St. shortly after six o'clock last evening. Mr. Richards was a native of Attleboro, where he was born over 68 years ago and was of an old and well known family.

### New York Notes.

LaPierre Manufacturing Co. have filed a judgment for \$89.43 against A. H. Seyd and H. D. Morrison.

Moritz Falkenau, of Falkenau, Oppenheimer & Co., sailed with his family on the *Lahn*, May 12th, bound on a pleasure trip through Europe.

Dr. R. H. Knowles, formerly of 4 Maiden Lane, has accepted the position of surgeon-in-charge of the refracting department of the L. Alexander optical establishment, 106 E. 23d St.

Anna B. Ackerman, wife of Wm. F. Ackerman, of the office of J. B. Bowden & Co., died Saturday, at her residence, 82 Bentley Ave., Jersey City. The funeral services were held Monday evening.

C. C. Adams & Co., of Brooklyn, have moved their business from the old stand at Fulton St. and Elm Place to the large and more pretentious establishment at 554 Fulton St., a few doors below Hanover Place.

Mrs. Provenzano, wife of J. N. Provenzano, manufacturer of silver novelties, 114 E. 14th St., died Sunday at her residence, 127 E. 104th St. The funeral services were held yesterday afternoon and the remains were interred at Woodlawn Cemetery.

The complaint in the suit by Max Freund & Co. to set aside the assignment of Chas. Seale, was dismissed Thursday, by Judge Beach, sitting in Part IV. of Special Term of the Supreme Court. Judgment for costs amounting to \$79.08 was entered by Seale against Max Freund & Co., Friday.

Holbrook & Simmons, manufacturing silversmiths, 427 E. 144th St., have dissolved by mutual consent, Henry B. Simmons retiring. The remaining partners, Eugene C. Holbrook and Wm. H. Thornton, will continue the business as before under the firm name of Holbrook & Thornton.

The R. Hoehn Co., manufacturers and importers of thermometers, barometers, etc., now at 125 Fulton St., have taken the upper floors of the building formerly occupied by Glaenzer, Frères & Rheinboldt, 80 and 82 Chambers St., into which their business will soon be removed.

Among the exhibitors at the National Electrical Exhibition at the Grand Central Palace are the American Watchman's Time Detector Co., Queen & Co., Philadelphia, Pa., and the Empire Self-Lighting Lamp Co. The "Tiffanyite," a phosphorescent diamond, is exhibited by permission of Geo. F. Kunz, of Tiffany & Co.

In the City Court, before Judge Sehuchman and a jury, May 12, the Fidelity Watch Case Co. recovered a verdict for \$2,073.50 against Chas. C. and Frank O. Murphy, composing the firm of Murphy Bros., for watch cases sold in 1890. With interest and costs the verdict aggregated \$2,275.83, and judgment for this amount was entered Wednesday.

Chas. Dietz, a partner of Julius Globe, jeweler, 434 Graham Ave., Brooklyn, took a novel way of dissolving the partnership last April,

and at the same time collecting a debt which he claimed Globe owed him, by opening the safe during his partner's absence and extracting \$175 worth of jewelry. In the County Court, Brooklyn, last week, Dietz was convicted of burglary and grand larceny.

Fred C. Steimann, for the past 19 years with F. W. Gesswein, has severed his connection with that house, and embarked in business for himself at 102 and 104 Fulton St. Mr. Steimann has formed a partnership with Jos. E. Worthington, Providence, R. I., and conducts business under the name of Fred C. Steimann & Co.

John Thompson, a colored boy, 18 years old, who has been employed by Simons, Bro. Co., 19 Maiden Lane, was sentenced to the Elmira Reformatory, by Judge Fitzgerald, in General Sessions Friday, on a charge of stealing seven diamonds from his employers. Thompson stole the diamonds Wednesday, but they were missed and he was suspected and arrested. He confessed his guilt and after being indicted Thursday, pleaded guilty to the charge.

Chas. A. Hess, counsel for the Diamond Importers' and Cutters' Protective Association, who has been invited to participate in the prosecution of Herman Keck, on the charge of smuggling, received word Monday from United States District Attorney Beck, at Philadelphia, where Keck is to be tried, that Keck's trial would not take place to-day. Keck, Mr. Hess expected, would be indicted Monday, both for smuggling and for conspiracy to defraud the government out of customs.

A meeting of the creditors of Henry Tissot, 51 Maiden Lane, who assigned May 4th to Eugene A. Gerdy, was held Tuesday afternoon, May 12, at the office of Kantrowitz & Esberg, Broadway and Worth St., and was attended by creditors representing about 75 per cent. of the liabilities. A proposition to settle at 25 per cent. paying in goods at cost price, met with the consent of the creditors present and papers embodying that basis of settlement are now in circulation. Mr. Tissot's assets are given as \$2,000.

A suit brought by Irving L. Russell to recover \$30,000 for alleged false imprisonment and malicious prosecution, against Justin Wertheimer, diamond importer, 41 Maiden Lane, was tried in the Supreme Court, May 12 and 13, before Judge Gildersleeve. Mr. Russell, who was formerly a diamond dealer at 18 John St., in January, 1894, was held in bail by Police Justice Koch, for the Grand Jury, on a charge made by Wertheimer of obtaining goods under false pretenses. The case was brought before Judge Lawrence, of the Supreme Court, on a writ of *certiorari* and Mr. Russell was discharged. Later, Mr. Russell commenced this action for damages, and after a two days' trial the jury disagreed.

Burglars committed a bold window robbery early Wednesday morning by smashing the side light of the show window of Lorenz Koloseus' jewelry store, 123 E. Houston St., and extracting two trays of jewelry valued at over \$1,000. The burglars were forced to cut through a wire

screen, which protected the window. Koloseus, who lives over the store, was notified by the policeman on the beat as soon as the robbery was discovered, but no trace of the thieves was found. His inventory showed that articles stolen consisted of ten gold ladies' watches, four gold men's watches, twelve silver watches, one gold comb, five pairs of diamond earrings, four diamond studs, two watch movements and one gold pen. Two gold watches, one gold hairpin and a silver match box were left in one of the trays. Detectives are working on the case.

Diamonds were accepted as security in lieu of bonds at the examination Thursday of Sigmund Morris, who was held by Commissioner Morle, in \$2,500 bail, on the charge of unlawfully using the mails. The accused offered the diamonds as security for the appearance of himself and other prisoners arrested on the same charge, and Asst. United States District Attorney Roy accepted the gems and consented they be released.

Actor Jno. R. Rogers, who was examined last week in supplementary proceedings against Simon Dessau, who failed in 1894, testified that Dessau had offered to let him have between \$20,000 and \$150,000, to put into the actual scheme, and told him that he had plenty of money under cover. Rogers also testified that Dessau told him that when he intended to pay any obligation he signed "S. D. Dessau," his mother's name, and when he did not pay he signed "S. Dessau." He said that on a western trip Dessau had plenty of money and had a pocket full of diamonds with him.

### Deputy Collector Hefferman Dismissed by the Treasury Department.

WASHINGTON, D. C., May 16th.—It has just become known that Deputy Collector Jas. H. Hefferman, of Montreal, against whom charges had been preferred, was recently peremptorily dismissed by the Treasury Department. Hefferman on March 30th caused the arrest of Alvin L. Strasburger, diamond importer, 10 Maiden Lane, whom he accused of attempted bribery. On Mr. Strasburger's examination April 14th Hefferman's testimony was in direct contradiction to his affidavit and complaint.

Charges were preferred against Hefferman and an investigation ordered. As a result of these charges, it is said that Collector Weed, of the Plattsburg district, recommended that Hefferman be permitted to resign. Supervising Special Agent Crowley asked that this recommendation be overruled and Hefferman be dismissed.

Assistant Secretary of the Treasury Hamlin sustained Mr. Crowley, and ordered Hefferman's dismissal about two weeks ago.

Of the many Summer novelties which are now being offered the jeweler, none are proving more popular than the combination belt and skirt supporter made by Deitsch Bros., 7 E. 17th St., New York. The holder is of sterling silver and is made on common sense principles. For simplicity, utility and security it affords the wearer, this article is without a peer. The supporter is made in three sizes: for 1, 1½ and 1¾ inch belts.



**Providence.**

By the recent assignment of Elbridge Flint, Littleton, N. H., local jobbers and manufacturers are interested for small amounts.

John Nelson, of whose conviction the manufacturing jewelers of this vicinity have been so desirous, has been granted a new trial. Nelson conducted a small retail store on N. Main St., and about two years ago, a large lot of scrap gold that had been stolen from Waite, Thresher & Co.'s shop was traced there and the parties selling it arrested. It was thought that Nelson was probably the fence through which quantities of stolen scraps have been disappearing for several years and of which no trace could be obtained, although the thieves were arrested.

The employes of the Gorham Mfg. Co.'s works were given a little surprise Saturday morning, when notices were posted in all the rooms stating that four days' time would be the rule for a few weeks to come. The works will be closed on Friday and Saturday of each week. This short time is something unusual at these works, although it has always been customary to close down for a week or two in the summer time. The secretary states that the works have been running very full for several months, and that there is a large stock on hand.

**The Attleboros.**

Charles Decker, counsel for James D. Lincoln, of Lincoln, Bacon & Co., was in North Attleboro the first of the week. Mr. Lincoln is anxious to settle up the affairs of this firm at once. At a recent meeting of the creditors he made a proposition which has not yet been accepted by all of the creditors, and it is rumored that Harland G. Bacon will never accept the proposition, although, as is generally known, nothing is to be gained by a refusal to accept Mr. Lincoln's terms.

**Syracuse.**

The May meeting of the New York State Association of Opticians will be held in Syracuse, Wednesday, the 20th, at 2 o'clock P. M. The topic, "Fitting of Frames," will be presented by James H. Morse, and following the business meeting the first annual banquet will be held at Hotel Florence.

H. J. Howe, formally opened his new store in the White Memorial building, corner of Vanderbilt Square and S. Salina St. on Tuesday last. The store was prettily decorated with palms and cut flowers and congratulations were the order of the day. Green is the prevailing color scheme employed in the decoration, which is very tastefully carried out, making a handsome contrast with the dark wood of the wall cases and furnishings. The arrangement of the store has been entirely changed, two show cases have been added and the Lamson cash system has been introduced. Altogether the store presents a fine appearance, and Mr. Howe's many friends wish for him a large measure of success.

**Special Notices.**

Rates 75c. per insertion for notices not exceeding 3 lines (25 words); additional words 2 cents each. If answers are to be forwarded, postage stamps must be enclosed. Two insertions, 15 per cent. off; three insertions, 20 per cent. off; four insertions or more, 25 per cent. off. Payable strictly in advance. Display cards on this page will be charged at \$2.00 per inch for first insertion, subject to same discount as above for subsequent insertions.

Under the heading of **Situations Wanted** on this page advertisements will be inserted for **One Cent a Word** each insertion, no discount. This offer refers to **Situations Wanted only**. Payable strictly in advance. If answers are to be forwarded, postage must be enclosed.

**Situations Wanted.**

*Notices under this heading ONLY are charged at one cent a word, payable strictly in advance. If answer are to be forwarded, postage must be enclosed.*

**SITUATION WANTED** as watch case repairer, or willing to start in business in any city where there are fair prospects of success; have all necessary tools. Address Repairer, care **JEWELERS' CIRCULAR**.

**OPEN FOR AN ENGAGEMENT**, by a first-class watch repairer and good engraver, capable of taking charge of store; own tools, highest of reference. Address X Ray, care **JEWELERS' CIRCULAR**

**Business Opportunities.**

**FOR SALE**.—Entire stock of jewelry, diamonds, watches and fixtures; good location and business in Hartford, Conn. Address H., care **JEWELERS' CIRCULAR**.

**\$3,000.** STOCK OF JEWELRY in the south for sale; established 1888; 3,000 population; a chance for some one. Address T., care **JEWELERS' CIRCULAR**.

**\$1,200** will buy my 6,800 lb. steel-lined safe, plate glass store fixtures and balance of my clocks and silverware; will sell watches and jewelry if wanted; best opening in Oklahoma for a live jeweler. Chas. E. Rose, El Reno, Oklahoma.

**FOR SALE** in Philadelphia, a desirable business in a fine locality; clean stock about \$8,000, which can be reduced if desired; walnut fixtures, fine regulator, safes, etc.; good run of work; established 12 years. Address O. E., care **JEWELERS' CIRCULAR**.

**SPLENDID CHANCE** for young man with small capital, in live town in Southside, Virginia; market place for six counties; five large tobacco warehouses; store excellently located; rent low; safe and other fixtures included. Address Mrs. Otto Salzman, Danville, Va.

**\$650.00** SPOT CASH buys fixtures, material and optical goods of leading jewelry and optical store; established 15 years; western New York; bench work \$1,500 per year; only optician; will sell any other part of stock if desired. Address J. O., care **JEWELERS' CIRCULAR**.

**To Let.**

**TO LET**—A good office on the third floor in the Diamond Exchange Building, 14 Maiden Lane, N. Y.; now occupied by the Fletcher Watch and Jewelry Co. This office will be rented very low to May 1, 1897. Apply to Janitor, or Smith & North, 14 Maiden Lane, N. Y.

**For Sale.**

**FOR SALE**.—A Marvin fire-proof safe; outside width 54 inches, height 65 inches, depth 28 inches. R. A. Loveland, 177 Broadway, N. Y.

**CHEAP**—Five burglar and fire-proof safes; handsome solid black walnut glazed office partitions, tables and other fixtures; also complete set of jewelry trunks. Max Freund & Co., 8 Maiden Lane, N. Y.

**WATCH** **GOLD FILLED.** **CASES**



**TO LET**

21 Maiden Lane, (HAYS BUILD'G).

**Three Fine Offices.**

BRUHL BROS. & CO., at Above Address.

**FOR RENT.**

Large Office, 5th Floor - - **Corbin Building.**

Will let very low for Three Years.

APPLY, - - - -

**JOSEPH FAHYS & CO.,**  
NO. 54 MAIDEN LANE, N. Y.



**COMFORT AND SECURITY**  
ARE COMBINED IN MERRITT'S PATENT EYE GLASS HOLDERS.

Made by Merritt, Garrill & Co. Springfield, Mass.

GOODS ON APPROVAL. CORRESPONDENCE SOLICITED.

ALL KINDS OF **S KELETON S**  
FOR **SILVERSMITH**  
MANUFACTURED BY **SCHULDER BRO S**  
FACTORY AT SOLINGEN, GERMANY. FOUNDED 1850  
545 & 547 PEARL ST., NEAR BROADWAY, NEW YORK

**SPECIAL** **NOTICES**  
IN **THE JEWELERS' CIRCULAR**  
Produce the results desired.

THE STAR OF EMPIRE WESTWARD TAKES ITS WAY!

# WESTERN SUPPLEMENT

## of THE JEWELERS' CIRCULAR

Chicago Office: Room 517, Inter-Ocean Building.

VOL. XXXII.

CHICAGO, WEDNESDAY, MAY 20, 1896.

No. 16.

### Chicago Notes.

Mrs. E. V. Roddin is on a pleasure trip in Europe.

D. A. Wilkins, of Ostby & Barton Co., is at the factory for a week or ten days' stay.

Manager Todd, of the Towle Mfg. Co., returned Monday after a short stay at the factory.

O. G. Fessenden, of Hayden W. Wheeler & Co., New York, was in Chicago the past week.

Mr. Copeland, of Martin, Copeland & Co., left for home Thursday, via Detroit, Cleveland and Pittsburgh.

E. H. Tucker, manager for Martin, Copeland & Co.'s New York office, is temporarily in charge of the Chicago office, vice C. S. Shepherd, resigned.

E. R. Crippen, of Bates & Bacon, is admiring the scenery and testing the fishing qualities of the Adirondacks on his annual two weeks' visit there.

Mr. Stanley, of Walton, Stanley & Fowler, has returned from Denver, Col., where a satisfactory trade was met with. East of Denver business was quiet.

An original and pretty idea is the sign shown by Bates & Bacon. On a black enameled metal plate 23x28 inches, three of the leading cases are represented by ladies in costume of the different ages, the illustration being in bright gold and finely executed. In an oval at the top the firm's "Favorite" is shown in the full length figure of a skirt dancer. Below this a figure of a royal lady of the 17th century illustrates their "Royal," and a Puritan woman in the garb of her people stands for their "Puritan" case. The signs are attractive and rich looking and will shortly be issued to the jobbing and fine retail trade who give particular attention to the Bates & Bacon lines.

### Kansas City.

Fred Dunn, with C. L. Merry, is home from a western trip.

W. B. Pinney has opened a very complete repair shop in Marceline, Mo.

C. O. Howe, formerly of Nickerson, Kan., spent last week in town among the jobbers.

J. A. Chopard, 1230 Grand Ave., is selling out his stock of diamonds and jewelry at auction.

Flint Bowen, representing Edwards &

Sloane Jewelry Co., has just left for a lengthy trip through Colorado, Utah and Montana.

Among the out-of-town buyers here last week were: E. C. Tieman, Huntsville, Mo.; L. Hoffman, Leavenworth, Kan.; D. P. Richards, Columbia, Mo.; Chas. M. Gleason, St. Joseph, Mo.; Geo. Essig, Plattsburgh, Mo.; B. R. Smithers, Cameron, Mo.; J. H. Whitesides, Liberty, Mo.; R. M. Walker, Monroe City, Mo.; O. Kolstad, Pleasant Hill, Mo.

### St. Louis.

Clementina Reichelt has given a bill of sale of \$2,800.

Seth E. Thomas, of the Seth Thomas Clock Co., New York, was here last week.

Col. Isaac Potter, of Potter & Buffinton, Providence, R. I., and State committeeman for that State, was here last week.

All the wholesale houses have sent out notices that henceforth they will close at 1 o'clock P. M. on Saturdays. This will be in effect until Sept. 1st.

Street hawkers in great numbers are on down town streets selling McKinley, Reed, Allison and other campaign buttons. They seem to do a thriving trade.

W. C. Barry, of Larter, Elcox & Co., New York, was here last week. He speaks encouragingly of his trip and says so far he has nothing to complain of.

The C. Boehmer Jewelry Co. are still selling at retail but it is positively announced that the auction sale of stock, fixtures, etc., will take place on the premises on Wednesday, May 20.

The jewelry trade is still very dull. Many of our firms complain of bad collections. J. A. Lucas, with A. H. Bliss & Co., manufacturers of gold plated goods, Chicago, says St. Louis is not alone in its complaints of bad business, but that the Lake City is with it on that score.

A. L. Steinmeyer, of E. Jaccard & Co., says the firm have doubled the force in their factory, and are working overtime. They have many orders for medals for tournaments, commencements, etc. One order this firm have just received is for 5500 sterling silver medals, enameled in two colors.

C. M. Perkins, president of the St. Louis Silver Co., 207 Chestnut St., is very well satisfied so far with 1896 business, it being larger

by a considerable margin than that of the same period of 1895. This firm are making a specialty of soda tumbler holders, and have just issued to the trade a circular relative to their quadruple plate on hard white metal.

Herman C. Grawe, jeweler, 441 Washington Ave., is one of our school directors and vice-president of the school board. He is a Republican in politics. A special election for a school director was to be held and the election's committee of the school board appointed judges and clerks, whom the Democrats claimed were not acceptable, as they have the right under the law to half of them being of that political party. The Supreme Court sustained the petition, and ordered the school board to appoint new judges and clerks, but they went ahead and appointed half of them over again. Thereupon they were cited to appear before the Supreme Court, in Jefferson City, and answer to the charge of contempt of court. They did so on the 12th inst., and were fined \$25 each and sentenced to ten days in jail. They were excused for a time until they went back to St. Louis and ordered an new election in conformity with the court's orders, but it is stated they will have to undergo their sentences in the near future. Mr. Grawe was one of the unfortunates, and there are seven other members of the board to keep him company.

### Cincinnati.

John Selbert, Frankfort, Ky., is in town buying goods.

Samuel Duncan, an old Arcade jeweler, has moved from No. 31 to No. 7.

S. V. Harding, Seymour, Ind., has gone to West Baden Springs, near French Lick, for his health.

C. L. Cross, Gadsden, Ala., is in Cincinnati, paying the jobbers a visit. Mr. Cross is on a trip to relatives up in the State.

Albert Bros. are headquarters for flat ware and have sold large quantities this season. A new line has just been received.

The early closers in Cincinnati beginning May 16th are: L. Gutman, Jos. Fahys & Co., Bene, Lindenber & Co., S. M. Peck, D. Schroder & Co., Peter Henry, Jos. Noterman & Co., W. T. Eichelberger & Co., A. G. Schwab & Bro., Frohman, Wise & Newman, Homan Silver Plate Co., J. S. Voss, O. E. Bell Co., Dennison Mfg. Co., Albert Bros., Stern & Co.

**Minneapolis and St. Paul.**

Eric Anderson, Oliva, Minn., recently removed to Winthrop, Minn.

H. H. Star, watchmaker, has opened in business in Richmond, Wis.

F. O. Fiske & Co., Minneapolis, recently remodeled their store front on the alley.

Simon Nelson, St. Paul, recently removed from 189 E. 7th St. to 183, same street.

H. J. Hanson, St. Paul, has removed his business from his former place to 353 E. 7th St.

W. B. Smith, St. Paul, has gone east on a business trip, and on his return will open in business at 391 Robert St.

Mr. Peck, representing O. W. Bullock & Co., Springfield, Mass., called on the Minneapolis jobbers the past week.

A. Lindahl, St. Paul, was re-elected Alderman of the 1st Ward on the Republican ticket, at the recent municipal election.

R. F. Lussier, formerly watchmaker for F. O. Fiske & Co., of Minneapolis, has accepted a similar position with M. L. Cohen, that city.

O. H. Arosin, St. Paul, was again elected Assemblyman of that city. Mr. Arosin was elected two years ago for the same place, on the Republican ticket.

A. L. Hamen & Co., St. Paul, removed from their old stand into the store room formerly occupied by W. B. Smith, in the Endicot building, Robert St. between 5th and 6th Sts.

Judge Belden, of the District Court of Hennepin County, has issued an order for the final accounting and settlement of the insolvent estate of the Reed & DeMars Jewelry Mfg. Co., Minneapolis.

All of the Twin City jobbers close their places of business Saturdays, except the Minneapolis Jewelry Mfg. Co., who have not yet completed their extensive alterations on their building. It is expected that they will fall in line.

**Detroit.**

E. R. Van Duser has purchased the interests of his partner, H. Kinch, Ithaca, Mich., and will continue the business.

F. M. Yerrick, one of Jackson's (Mich.) most prominent jewelers, has gone to Martinsburg, W. Va., where he will engage in the business again.

James M. Thompson, who was for many years bookkeeper for M. S. Smith & Co., died last week. He leaves a widow and four children.

Jeweler Beardsley, Grand Lodge, Mich., was here last week. He was resting after an operation performed on his eyes by specialists at Ann Arbor.

James W. Frisbie, a wealthy retired business man of Detroit, died last week. He was the father-in-law of William A. Sturgeon, of Smith, Sturgeon & Co.

L. Black & Co. announce that they will shortly remove from 145 Woodward Ave.

across the street to 156 Woodward Ave. A new business block will be erected on their present site.

Jeweler H. M. Avery, South Haven, Mich., a pioneer of that city, has sold his business to William Falls, Schoolcraft, Mich., and will retire from the business.

Three years ago while Rose Coghlan was playing an engagement here, she purchased \$400 worth of diamonds from F. G. Smith, Sons & Co. Nothing was paid until last winter, when she again visited Detroit. John T. Sullivan, her husband, paid \$50 upon receiving a note from attorney Boynton, who has since been made the assignee of the firm. The matter was placed in the hands of New York attorneys. Each of the clerks of the New York firm failed in serving a summons on her. William Halperin was engaged to serve them. He called four times and was told each time that Miss Coghlan was not in. The next time the maid slammed the door in his face. Halperin then waited until they came out, and then stepped up in front of them. Miss Coghlan said: "Don't make a scene and I will take the papers." Mr. Boynton says he urged Mr. Sullivan to return the diamonds, but the latter neither did so nor kept his promise to pay the account.

It promises to be satisfactorily settled now.

**Indianapolis.**

Jeweler Hollingsworth, of Greentown, Ind., called at the jobbing houses last week on his

way to West Baden Springs. He is taking a trip on a wheel.

Craft & Koehler have enlarged their office and watchmaker's quarters.

Phelps & Bernadi, Lafayette, Ind., have recently opened a branch store in Crawfordsville, Ind.

H. E. Duncan and T. L. Lake, of the American Waltham Watch Co., called upon the trade May 9th.

H. A. Winn has given up the commission business in this city and returned to the jewelry trade in Newman, Ill.

Jas. N. Mayhew is cutting a window in his work room and otherwise improving his optical rooms on North Meridan St.

Richard Brandes, Anderson, Ind., has been arrested, charged with having left town with several watches intrusted to him for repairs.

Traveling men in Indianapolis last week included: J. T. Metcalf, R. Blackinton & Co.; Mr. Bliss, Gorham Mfg. Co.; Wm. Manheimer, for Louis Manheimer; Rudolph Noel, Albert Lorsch & Co.; Mr. Abbey, E. Ira Richards & Co.; Coleman E. Adler, Byron L. Strasburger & Co.; E. Stein, Wendell Mfg. Co.; Jos. Becker, Fahys Watch Case Co.; W. J. Miller, Seth Thomas Clock Co.; T. L. Lake and H. E. Duncan, the American Waltham Watch Co.; Theo. Wagner, for R. A. Breidenbach; and representatives of Coddling Bros & Heilborn, Burt Ramsey & Co., and I. W. Friedman.

**THIS ADV. IS WORTH MONEY** When cut out and sent with an order to the amount of \$5.00 or more, it is good for 25c. in payment. On an order for less than \$5.00 is good for 10c.

**COLUMBIA BICYCLE BELT,** made in Black, Brown and Green Seal or Brown and Green Imported

Pebble, Tan, Pig Skin, Dark and Brown Russia, Bok, etc.

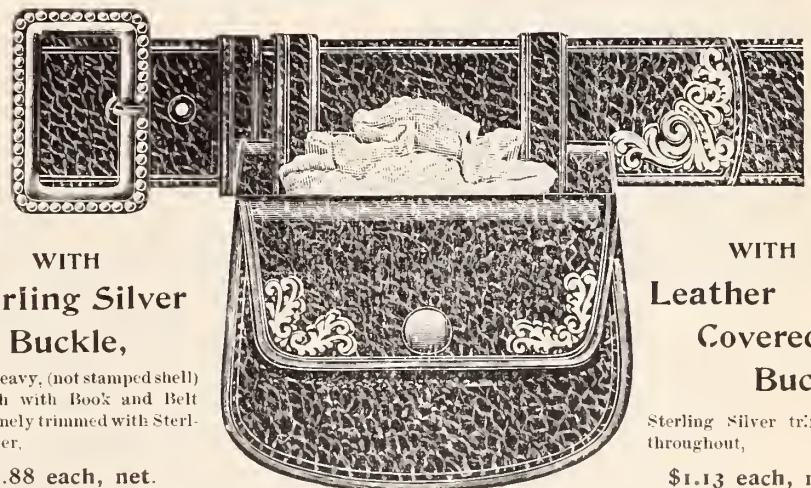

**WITH Sterling Silver Buckle,**

extra heavy, (not stamped shell) 1 1/2 inch with Book and Belt handsomely trimmed with Sterling Silver.

\$1.88 each, net.

**WITH Leather Covered Buckle,**

Sterling Silver trimmings throughout,

\$1.13 each, net.

**1 1/2 inch Belt,** special grain leather covered buckle, plain round corner chatelaine, belt and book trimmed in Sterling Silver, special at 55c. each, net.

**We have a Special Line** of 1 1/2 inch lined belts with leather covered buckles to match. at from \$1.50 to \$5.50 per doz.

**Same,** with sterling silver trimmings, at from \$6 to \$9 per doz.

**We manufacture these goods throughout from raw material, hence the extra values.**

ORDER SAMPLES AND ILLUSTRATED SHEET.

**THE O. E. BELL CO.,** Manufacturers, Cincinnati, Ohio.

## Rhode Island Adopts an Honest Silver Law.

PROVIDENCE, R. I., May 15.—To-day, after more than two years of hard work before the Legislature of this State, the advocates of honest silver reaped their reward by the final passage of the "Sterling Silver" bill, which was given in full in THE CIRCULAR of April 29.

Two years ago a somewhat similar bill was introduced in the House of Representatives, through the efforts of the Gorham Mfg. Co., and passed without any opposition. It was also passed by the other branch of the Legislature, but before it was returned from the Committee on Engrossed Acts, for final adoption, Representative Henry G. Thresher, at the urgent request of several manufacturing jewelers of this vicinity, asked that it be reconsidered, which, being granted, there was a long hearing held and the bill was left on the files at the conclusion of the

session. In January of this year, the bill passed to-day was introduced and went through the House, no one appearing in opposition at the public hearing held and was sent to the Senate for concurrence. At the hearing held by the Judiciary Committee of this body a three hours' session was the result and a number of the manufacturing jewelers opposed its passage and when it was thought that the bill was likely to pass, several suggestions were made calculated to impede to a certain extent the operativeness of the bill or its immediate effect. After careful consideration the Judiciary Committee reported the bill back to the Senate on Tuesday with the recommendation that it be adopted, which was done and the bill sent to the Committee on Engrossed Acts, by whom it was reported to-day and the bill has now become a law of Rhode Island.

### Odds and Ends of News.

T. A. Somdal, Mansfield, Ill., has given a bill of sale for \$560.

Louis Diebeck, Great Falls, Mon., has given a chattel mortgage of \$100.

E. F. Mechler, Eagle River, Wis., has removed to Marshfield, Wis.

D. F. Wetzel, Spokane, Wash., lately gave a realty mortgage for \$12,000.

A judgment of \$341 has been issued against Noah Brunner, Ridgway, Pa.

The store of A. B. Stackhouse, Warrensburg, N. Y., was recently burnt out.

C. S. Wahlstedt, lately of Scotland, S. Dak., has removed to Tyndall, S. Dak.

A chattel mortgage for \$500 was recently given H. P. Perkins, Clarion, Ia.

A judgment for \$4,000 was issued against Elias K. Kulp, Lederachville, Pa.

E. C. Putnam, lately of West Boylston, Mass., has removed to Millbury, Mass.

Popliff & Co., St. Paul, Minn., have been sold out and a trustee has been appointed.

L. K. Silverson, formerly of Rothsay, Minn., is now in business in Willow City, N. Dak.

Charles T. Gross, jeweler, Albany, N. Y., who was arrested charged with the larceny of several watches belonging to patrons, was examined last Tuesday. On the charge of grand larceny, he was held for the Grand Jury, while the petit larceny count was dismissed.

The business of Alford & Eakins, engravers and printers, 73 Nassau St., New York, has of late grown to such an extent that the firm have been obliged to take another floor. They now occupy three floors. A new feature of their business is the putting up in packets, assortments of stampings, seals, crest, monograms, etc., in colors and illuminated. These goods are sold through the retail trade, and are bought by collectors. The prevailing fad of using these clippings for the decoration of plates, etc., will doubtless result in large sales of these packets.

## Indictments against Herman Keck and Capt. Loesewitz.

PHILADELPHIA, Pa., May 18.—True bills of indictment were found by the Grand Jury, in the United States District Court, to-day, against Herman Keck, of the Coetermans-Henrich-Keck Diamond Cutting Co., Cincinnati, O., Captain Franz Loesewitz, of the steamer *Rhynland*, and one Von Hemebrick, in connection with the alleged smuggling of 563 diamonds valued at \$10,000, into this country.

In the indictments as passed upon by the jury, Keck and Loesewitz are directly charged with smuggling and Von Hemebrick is accused of conspiracy. It is further alleged that the defendants did "knowingly, willfully, unlawfully and fraudulently conspire, combine, confederate and agree together between and amongst themselves to commit an offense against the United States."

No time has yet been fixed for the trial of the case.

### New Jewelry Businesses.

F. C. Martin, Pearl River, N. Y.

D. S. Farsons, of Winston, N. C., will open a store at Avon Park, Fla.

S. T. Little & Sons, jewelers, Cumberland, Md., have opened up a jewelry store in Lonaconing, Md.

George Jay, formerly electrician for the Priceburg Electric Light Co., Priceburg, Pa., will soon engage in the jewelry business in Scranton, Pa.

### Connecticut.

There has just been recorded in Wallingford the transfer of the property of the Maltby, Stevens & Curtiss Co. to the Watrous Mfg. Co., which includes the factory, machinery, manufactured goods and stock, real estate and water privileges for \$25,000, subject to a mortgage of \$34,528.60. The Maltby, Stevens & Curtiss Co. for the \$25,000 take \$25,000 worth of stock in the Watrous Mfg. Co.

A new corporation has just been formed in Middletown for the manufacture of cut glass ware, to be known as the E. T. Burgess Cut Glass Co. Mr. Burgess, head of the concern, lately removed his business from Meriden to Middletown. His goods are well known to the jewelry trade. The capital stock of the new company is \$8,000 divided into 320 shares of \$25 each. The subscribers to the stock of the new company and number of shares taken, 20 per cent. being paid at once in cash, are: Augustus Kinley, 12; Adolph Ecker, 16; C. B. Leach, 8; H. L. Barton, 12; Charlie Fountain, 8; A. B. Calef, Jr., 8; Ryan Barrows & Parker, 20; James P. Stow, 8; Edward F. Burgess, 204; Henry J. Burgess, 8; D. I. Chapman, 8; Robert W. Burke, 8. Jewelers Ryan, Barrows & Parker, Middletown, have a very pretty window display of cut glassware, the product of the Burgess Cut Glass Co.

## THE PERFECTION SHOW CASE

FOR FINE JEWELRY TRADE.

WE CHALLENGE THE WORLD TO PRODUCE ITS EQUAL.



IF YOU ARE INTERESTED IN SHOW CASES AND JEWELRY FURNITURE, WRITE US FOR FULL INFORMATION.

## A. H. REVELL & CO.,

431 to 437 Fifth Avenue, Chicago.

**PARSONS & SCHOOL**  
FOR  
**WATCHMAKERS,**  
PEORIA, ILL.  
Send for Circular and Terms  
**PARSONS & CO.**

**New Bedford, Mass.**

Edmund E. Baudoin, lately an engraver with the Pairpoint Mfg. Co., has opened an engraving shop on his own account on Union St.

Henry B. Howland, who last Winter enlarged his store to nearly twice its previous size by adding on the store next south, has just completed its attractiveness by putting in a new plate glass front, giving him one of the most desirable jewelers' stands in the city.

Edward Taylor, of the Pairpoint Mfg. Co., was one of the speakers at the annual banquet and reunion of the Fairhaven Improvement Society. Mr. Taylor, Thomas A. Tripp, and Nat Pope, all of the Pairpoint company, were elected members of the executive council of the organization.

At the Veteran Cadets' banquet, a few days ago, THE CIRCULAR correspondent declined reelection as president of the organization, after constant service in that capacity for four years. In the new list of the association's officers, Francis K. Allen, treasurer of the Pairpoint Mfg. Co., was elected vice-president of the society.

**Worcester, Mass.**

Arthur Flagg and A. B. F. Kinney have been granted door office licenses.

H. Lucke has furnished the set of prizes for the City Guards' outdoor games on Memorial Day.

The creditors of Nelson H. Davis held their second meeting in the Court of Insolvency Tuesday. Claims were proved and the debtor took the oath.

C. M. McFarland has presented a bicycle watch and chain for the Vernon and Worcester Bicycle Club road race. He furnished the onyx clock for the winning team.

**Pacific Coast Notes.**

F. A. Conant, jeweler, Santa Barbara, Cal., has moved his stock to the store of H. F. Maguire, that city.

Carl King has purchased the jewelry business of L. A. Kerr, Kendrick, Idaho. He will

continue to conduct a well equipped jewelry store in the White block.

Theo. B. Starr, New York, has arrived at Santa Barbara, Cal., in his private car, Viceroy. He will remain there for some time.

The officers of the Oregon Retail Jewelers' Association recently formed at Portland, Ore., for mutual protection of the members are: President, W. Friedlander; vice-president, G. Heitkemper; secretary, A. S. Heintz; treasurer, Horace Butterfield.

O. M. Campbell, jeweler, Petaluma, Cal., has received a despatch from Los Angeles, informing him that judgment in his favor has been rendered in the suit brought against him by his creditors in the Superior Court of that county. In January Campbell assigned his stock in Petaluma, for the benefit of his creditors. It was then alleged that he had previously transferred some of his stock to a jewelry store belonging to him in Los Angeles, and that he had made over his stock there to his sister, Mrs. Preston. The creditors closed up the Los Angeles store on account of Campbell's debts, but the court has now decided that they had no jurisdiction in doing so, as the property was not Campbell's. Mrs. Preston will bring an action for damages against those who were plaintiffs in the suit just decided, to recover the sum of \$12 per day for every day her store was by them kept closed.

**IT KNEW HIS PECULIARITIES.**

Mrs. MORK (an Oklahoma matron)—I wonder what is the matter with the clock? The pesky thing went wrong jest about the time Alkali Ike began callin' on you, and it hain't been anywhurs near right since. Ike don't tamper with it, does he?

MISS GLADYS MORK—No, ma'am, but every time he comes in the clock stops and throws up its hands.—Chicago Record.

**PHOTO-MINIATURE.  
PORTRAITS \$1.50  
ON  
WATCHES**

**The Goldstein Engraving Co.,  
1 MAIDEN LANE, NEW YORK, N. Y.**

**AMERICAN WATCH CASE CO.,**

11 JOHN STREET, NEW YORK.

Manufacturers of **FINE SOLID GOLD CASES.**



Sold DIRECT to  
the RETAIL TRADE only.

**S. M. LEWIS & CO.**

SILVER GOODS A SPECIALTY.

37 and 39 MAIDEN LANE, NEW YORK.

**Have Removed**

To the

**LORSCH BUILDING,**

ESTABLISHED HALF A CENTURY.



**HAVE MANY PATENTED IMPROVEMENTS NOT FOUND IN OTHER MAKES THAT WILL WELL REPAY AN INVESTIGATION BY THOSE WHO DESIRE TO SECURE THE BEST SAFE**  
**MARVIN SAFE CO.**

12 PARK PLACE, NEW YORK.

**FISHING**



**TACKLE.**

**To Dealers Only.**

**SPLIT BAMBOO RODS,**  
From \$10.80 per doz.,  
to \$76.50 each.

**ALL LANCEWOOD RODS,**  
From \$9.90 per doz.,  
to \$3.00 each.

136 page Catalogue Free.  
Send for it.

**ABBEY & IMBRIE,**  
21 VESEY ST.,  
New York.

**DR. KNOWLES' PRIVATE COURSE IN OPTICS.**

Lectures with Diploma \$25.00

Those who desire to study with the Doc will send in their application.

Students received at any time.

CORRESPONDENCE COURSE PERFECTED.

*The Key to the Study of Refraction.*

50c. per copy,

For Sale by

**R. H. KNOWLES, M. D.,**  
189 Broadway, NEW YORK  
Care of JEWELERS' CIRCULAR.

**A. J. COMRIE,**

AUCTIONEER,

22 John St., N. Y.

SPECIAL SALESMAN OF WATCHES, DIAMONDS  
BRIC-A-BRAC, FOR ESTABLISHED JEWELERS.

WRITE FOR PARTICULARS



MADE BY HENRY C. HASKELL,  
11 John St., New York.

Send For New Price List.



A Large Number of Small

## Advertising Cuts

Specially Designed for JEWELERS'

ADVERTISING, such as above, at

75 Cents per Electrotype.



SEND FOR PROOF SHEET.



THE JEWELERS' CIRCULAR PUB. CO.,

189 Broadway, New York.

**JOHN T. PECK,**  
**WATCHMAKER**  
—FOR THE TRADE.—

409 WASHINGTON ST.,

Room 15.

BOSTON, MASS.

FOR RELIABLE OPTICAL WORK

SEND TO

JOS. FRIEDLANDER & BRO.,

OPTICAL LENS GRINDERS,

9 MAIDEN LANE, - - - NEW YORK.

SEND FOR DESCRIPTIVE CIRCULAR OF OUR FRAME AND LENS CABINET.

**O. NEWMAN,**  
Gold and Silver Electro-Plater.  
Etruscan Coloring a Specialty.  
WATCH CASE POLISHING.

75 Nassau St., Room 8 Rear Building, New York.



**REGINA**  
MUSIC BOXES

A. WOLFF,  
General Agent.

LINCOLN BLDG., 14th  
St. & Union Sq. W., N.Y.



Send 40 Cents For sample of our steel E. G. frame with Imperial guard in Imperial case. Levy, Dreyfus & Co., Wholesale Opticians, 9-11 Maiden Lane, New York.

**H. M. RICH & CO.,**  
**Jewelry - Auctioneers,**  
21 School Street,  
BOSTON, MASS.

## News Gleanings.

The death is reported of G. W. Barrett, Boone, Ia.

Eva Rose, Joplin, Mo., has given a trust deed for \$7,850.

D. F. Wetzel, Spokane, Wash., has given a mortgage for \$1,200.

J. W. Rode is about to open a jewelry business in Minto, N. Dak.

Sol. Aaron, Spokane, Wash., has given a chattel mortgage for \$214.

I. P. Riley has sold out his jewelry business in Montpelier, Idaho.

Andrew L. Siepel, Denver, Col., has given a chattel mortgage for \$120.

H. P. Perkins, Clarion, Ia., has given a chattel mortgage for \$5,000.

D. O. Lukenbill, Milo, Ia., has recently sold real estate amounting to \$1,650.

C. H. Leggett, Merced, Cal., has filed a voluntary petition in insolvency.

Judgment has been entered against H. J. Heinrichs, Sedalia, Mo., for \$105.

The jewelry store of J. W. A. Redhouse, St. Mary's, Kan., has been attached.

C. H. Morris, The Dalles, Ore., has given a chattel mortgage for \$146 on his safe.

Waters & Scott, Lead, S. D., have opened up a branch jewelry store in Terry, S. D.

Donelson & Co., Des Moines, Ia., has given a chattel mortgage for \$400.

A. Helfferich, Laramie, Wyo., has turned over his business to the First National Bank.

John McBeth, Wakefield, Kan., has given a chattel mortgage on his jewelry business for \$50.

The death is reported of Frank J. Wood, dealer in jewelry and stationery, Georgetown, Col.

In a fire in Lincolnville, Fla., a few days ago, the jewelry store of George Edwards was burned out.

The jewelry and notion firm of Dinwoodie & Fleming, Redlands, Cal., have dissolved partnership.

In a disastrous fire in L'Anse, Mich., May 9th, the jewelry store of Thomas Brady was burned out.

W. J. Grafmiller, Sacramento, Cal., has admitted J. R. Heath, as a partner in his jewelry business.

Harry Davis, Trinidad, Col., has sold out his confectionary business, but still retains the jewelry store.

M. H. Richmond has removed from Williamson, N. Y., to Newark, N. Y., where he has opened a jewelry store.

J. B. Bruce, Burgettstown, Pa., has moved his jewelry establishment into the building adjoining the Exchange Hotel.

Jeweler I. L. Pearl, Mt. Carmel, Pa., is in Philadelphia under treatment for rheumatism at the Jefferson Medical College.

G. Fred Gallup, jeweler, Catlettsburg, Ky., has been appointed as official watch inspector for the Norfolk & Western R. R.

Carl T. Lundquist died at Wells hospital Butte, Mon., last week, of appendicitis. He was a jeweler by trade and 32 years old.

Donelson & Co., Des Moines, Ia., have given a chattel mortgage to M. A. Lombard for their stock of jewelry at 504 Walnut St., the consideration being \$400.

The Chauncey Knight jewelry store in Dalton block, Pittsfield, Mass., is closed, and Mrs. Knight has taken an inventory of the stock. She has not as yet decided what she will do.

A rear door was forced at the jewelry store of Wm. Connelly, Louisa, Ky., last Monday night, and watches to the amount of \$350 in value were taken.

Robert Jenkins, of Jenkins' jewelry store, Richmond, Ind., has sold his interest in the business to his brother, Will Jenkins. For some time past Robert has wished to go into a new line of business.

William H. Spilling, a jeweler, and Miss Rosa Schuman, daughter of Julius Schumann, proprietor of the jewelry establishment at 631 E. Broad St., Richmond, Va., eloped to Washington, May 12, and were married there shortly after their arrival.

The Hanf Optical Co., 811 Shipley St., Wilmington, Del., has purchased the entire jewelry stock and fixtures, formerly the establishment of E. E. Hanf. The new company will close out the stock of jewelry, diamonds, watches, clocks and silverware at 717 Market St.

The jewelry firm of Joseph Sarphe & Co., Baton Rouge, La., have sold out to Roumain Bros., who will run the former store as a branch of their old established business. The action of Joseph Sarphe & Co. was due to pressing debts and judgments, and dissension between the partners.

The jewelry store of Meinhoefer & Larosh, 7th near Linden Sts., Allentown, Pa., was placed in the hands of the sheriff May 11th. The firm failed on the following executions: H. G. Bailey & Co., \$550; Non-Retailing Co., \$208; B. J. Cooke's Sons, \$180. Shortly after Sheriff Schwyer levied on the store and the sale was set for May 18th.

One of the large glass windows in Lanier's jewelry store, Waycross, Ga., was broken on the night of May 10 by some unknown party, and the window robbed. The glass seemed to have been broken with a brickbat. A fine revolver is the only thing of much value that has been missed, but several other articles of smaller value, which were in the window, are thought to have been stolen. The glass cost \$60.

Special policeman Gill found two suspicious persons in an alley at the rear of Rubenstein Bros.' jewelry store, Schenectady, N.Y. late last Saturday night and arrested them. At the police station the prisoners gave their names as Richard Jessup, aged 17 years, and Michael Murphy, aged 18 years. Later it was found that a hole had been cut through the rear door of the jewelry store near the latch, and a piece of wire inserted.

**Philadelphia.**

Lewis P. White has returned from a trip to Atlantic City.

Geo. Eakins & Co. will soon undergo a change, Mr. Parke retiring from the business.

Francis J. Ligg is making a specialty of rings with political designs, intended for the coming presidential campaign. He expects to find customers among members of both the Republican and Democratic parties.

Dr. Walter H. Keyes, president of the Mississippi Medicine Company, who tried, with alleged fraudulent intent, to mix jewelry trade features with the medicine business and experienced disastrous results, has been taken to Pittsburgh, where he is wanted to answer a charge of larceny.

Manager J. Walter Peele and clerk George Wolfe, who distinguished themselves in recovering a stolen package of diamonds from Simons, Bro. & Co.'s New York establishment, are well known in this city, and the Philadelphia members of the firm are much pleased by their acuteness in capturing the thief.

The five-story building of the Ledig Silver Mfg. Co., in the rear of 248 N. 8th St., narrowly escaped destruction by the fire that broke out on the fourth floor soon after 2 o'clock on the morning of May 9. Members of the firm estimate the damage at about \$40,000 upon the building and stock, covered by insurance.

The annual convention of the National Retail Jewelers' Association will be held in Atlantic City, July 14, 15, 16. Members of the trade here are beginning to talk over the coming event and there will probably be a large representation from this city, not only of members of the local organization, but of representatives of the trade generally.

**Boston.**

M. Myers has gone south on an extended business trip.

D. C. Percival & Co. have added cut glass ware to the line of goods handled by the firm.

Buyers in town during the past week included: H. S. Twombly, Biddeford, Me.; W. B. Studley, Rockland, Mass.; Harry Whittemore, Milford, Mass.

Joseph Angell, of Link, Angell & Weiss, Newark, N. J., has been passing a portion of his honeymoon in Boston, having arrived in this city with his bride last week.

The marriage of Walter G. Ailman, the Boston optician, to a lady of Detroit, Mich., took place April 15, in the latter city. A reception was given by Mr. and Mrs. J. H. Ailman, parents of the groom, to the young couple last Monday at the Hotel Vendome, this city.

The old and well-known firm of Bigelow, Kennard & Co. were dissolved by limitation the first of last April, and Wm. S. Foster retired from the business. Mr. Foster has been connected with Bigelow, Kennard & Co. for 26 years, and for the last six years has been a partner in the house. He was always to be

found at his place of business, and will be greatly missed by those who were in the habit of meeting him there.

**Pittsburgh.**

S. Frank has opened a new store on Fifth Ave., Sixth ward.

James Brown, G. B. Barrett & Co., is in the city for a week.

Mr. George W. Biggs lately purchased property in the East End for \$9,000 which will be the site of a handsome residence.

Miss Dorothea Schaefer, daughter of Joseph M. Schaefer, was married Thursday last to Austin Bailey, of this city.

B. E. Arons and family will go this week to their summer home at Aronsdale, N. Y. Mr. Arons will make weekly visits to his store.

Heeren Bro. & Co. have completed the bronze wreaths contributed by the local Hungarian patriots to be placed upon the grave of Kosuth.

E. B. Kuntz, Natrona, Pa., who was watchmaker for the past six years for Paul Rudert, Tarentum, Pa., has opened a retail store in Natrona.

THE CIRCULAR correspondent was informed that E. A. Pratt, Columbus, O., has opened a new store on S. High St., opposite the Chittenden Hotel.

Charles C. Corcoran has opened his new retail store at 502 Wood St., a good location. Mr. Corcoran was lately a member of the wholesale firm of Corcoran & Vilsack.

Visiting jewelers in the city last week were: J. Morrison, Mt. Pleasant, Pa.; N. C. Cochran, Fairmont, W. Va.; F. H. Marshall, Derry Sta., Pa.; Mr. Miller, of S. M. Bailey, Uniontown, Pa.; J. F. Zugschwert, Carnegie, Pa.; C. A. Loughman, McKees' Rocks, Pa.; Frank Weylman, Kittanning, Pa.; P. J. Manson, Jeannette, Pa.; E. B. Kuntz, Natrona, Pa.; F. N. Hayes, Washington, Pa.

The O. E. Bell Co. Cincinnati, have received a large order from San Francisco, for leather belts that they are now manufacturing. They have increased their factory force and from the many orders that are coming in daily it looks as though they will have to add another floor. The "Columbia" is a specialty with them and has become a popular leader. It combines the pocket book with the belt, and is especially adapted for bicycle riders.

**OPPENHEIMER BROS. & VEITH,**

**CUTTERS OF DIAMONDS,**

**DEALERS IN WATCHES,**

65 NASSAU STREET (PRESCOTT BUILDING), NEW YORK.

Send for Catalog         
 showing complete line, over 40 subjects, of the beautiful  
**Rogers Statuette Groups...**

Genuine American Sculpture. Popular Art at Popular Prices.  
 ROGERS STATUETTE CO., 441 Pearl St., N. Y.

WE CATER TO THE JEWELRY AND STATIONERY TRADES ONLY.

**ALFORD & EAKINS,**

Successors to Henry G. Alford

73 Nassau Street, New York.

ENGRAVERS, PRINTERS and EMBOSSERS,

Manufacturers of fine Wedding Invitations, Reception and Calling Cards, etc., etc.

We guarantee our workmanship equal to our samples, and superior by comparison to any now on the market. TRY THEM.



The Latest Patents.

ISSUE OF MAY 12, 1896.

**559,805.** CHIME. WYLLYS C. LADD, Bristol, Conn.—Filed Nov. 11, 1895. Serial No. 568,555. (No model.)

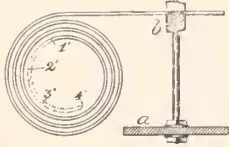

A chime or similar musical device, comprising in its construction a series of gongs consisting of wires combined with a sounding bar upon or in connection with which one end of each wire is placed and a clamp for clamping each wire so that they may be readily adjusted to extend at varying distances from the bar.

**559,820.** MICROMETER GAUGE. JOHN T. SLOCUMB, Providence, R. I., assignor to J. T. Slocumb & Co., same place.—Filed Nov. 19, 1894. Serial No. 529,338. (No model.)

**559,840.** JEWELERS' TOOL. ROBERT N. BROMLEY, Des Moines, Iowa.—Filed July 20, 1894. Serial No. 518,080. (No model.)

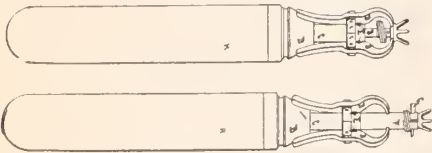

In a jeweler's tool, the combination of a handle having a nut in its end and a free end of the nut tapering, a screw fitted in said nut and provided with spring-actuated jaws, and a socket in its other end, and a setting holder having a stud fitted in said socket.

**559,853.** PNEUMATIC CLOCK SYSTEM. WARREN S. JOHNSON, Milwaukee, Wis. Filed Oct. 15, 1895. Serial No. 565,707. (No model.)

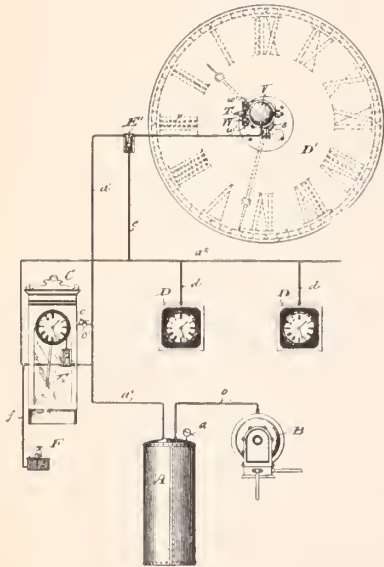

In a pneumatic clock or time system, the combination with one or more time indicating or recording devices, of a fluid-pressure motor for actuating the same, a source of fluid-pressure connected with said motor, or valve controlling the admission and release of the actuating fluid to and from said motor, a secondary fluid-pressure motor for actuating said valve, a sensitive secondary valve controlling the supply of actuating fluid in the secondary motor, and a master-clock arranged to directly actuate said secondary valve at stated intervals whereby the said time indicating or recording devices are operated synchronously with said master-clock.

**559,889.** ELECTRIC CLOCK. BENJAMIN FRANK-

LIN (Mary A. Franklin administratrix of said Benjamin Franklin, deceased) and DAVID H. FLETCHER, Chicago, Ill., assignors of one-half to George H. Merriell and Calvin R. Beach, same place. Filed Apr. 11, 1893. Serial No. 469,953. (No model.)

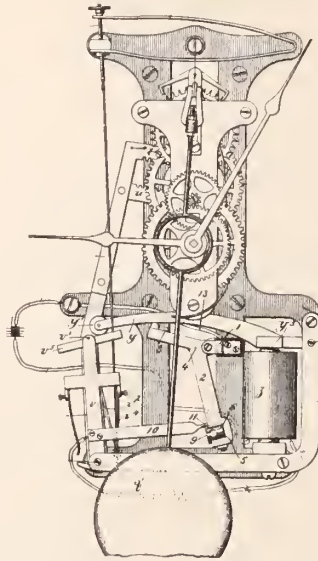

The combination with a clock train, of a pivoted lever in operative connection with the driving arbor of the train, means for actuating said lever, a shifting device for alternately changing the direction of its movement, an armature in operative connection with said shifting device, a source of electricity, and means for automatically making and breaking the electric circuit at regular intervals corresponding to the movement of said driving lever.

**560,076.** ELECTRIC PROGRAM CLOCK. ALFREDO ANTONIO CABDOSO E. BASTOS, Sao Paulo, Brazil—Filed Mar. 20, 1894. Serial No. 504,428. (No model.) Patented in Brazil Nov. 25, 1893, No. 1,664.

**560,092.** SUPPORT FOR BLOWPIPES. GEORGE

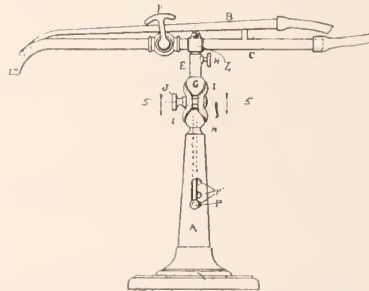

R. FORD and DAVID ALEXANDER, Chicago, Ill.—Filed July 15, 1895. Serial No. 556,079. (No model.)

**560,113.** CLOCK-CASE. ADAM SCHEFFER, New York, N. Y.—Filed Sept. 13, 1895. Serial No. 562,374. (No model.)

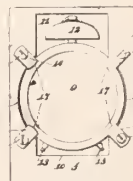

A clock-case, comprising a front plate having a circular central aperture, side pieces of thickened material extending along the sides of the front plate, a top and bottom secured to the upper and lower end of the side pieces, said side pieces being provided with recesses in their inner surfaces and at opposite sides of the central aperture in the front plate, said recesses being correspondingly curved and concentric with the central opening in the front plate, and being adapted to receive the opposite sides of a circular clock, and hold said

clock in position with its dial aligned with the opening in the front plate of the casing, the curve of the recesses in the side pieces being of greater radius than the curve of the central opening in the front plate, whereby a shoulder is formed at the junction between the side pieces and the front plate adapted to hold the clock inserted in place, and fastening devices located at the rear part of the casing and adapted for engagement with a clock inserted therein, to hold said clock against removal.

**560,156.** EYEGLASSES. JOSEPH H. E. DECELLES, Southbridge, Mass., assignor to the American Optical Co., same place.—Filed Oct. 3, 1895. Serial No. 564,486. (No model.)



In a two-bar spring or bridge for eyeglasses, the two bars arranged in a horizontal plane at some distance apart, and the inner bar bent outwardly, downwardly, and inwardly, with the lower attaching end flattened to form an integral bridge side arm, and the outer bar bent inwardly, downwardly and inwardly, with the lower attaching end flattened to form an integral side arm, and two yokes or plates secured on each bar, and adapted to slide loosely on the other bar, and a spring mounted on one bar intermediate two of the plates.

DESIGN 25,467. BADGE. HENRY A. SMITH, At-



lanta, Ga.—Filed April 23, 1895. Serial No. 547,569. Term of patent 3 1/2 years.

DESIGN 25,468. BUTTON. ALBERT B. SCHOFIELD,



Brooklyn, N. Y.—Filed March 19, 1896. Serial No. 978. Term of patent 3 1/2 years.

DESIGN 25,473. STAND FOR CHAFING DISHES. LOUIS WOLDKOW, Brooklyn, N. Y. Filed April



11, 1896. Serial No. 587,218. Term of patent 3 1/2 years.

TRADE-MARK 28,250. WATCH MOVEMENTS. HAMPDEN WATCH COMPANY, Canton, Ohio. Filed April 2, 1896.

MOLLY STARK

Essential feature.—The words "MOLLY STARK," Used since Feb. 1, 1896.

TRADE-MARK 28,253. TOOLS, INCLUDING EDGE TOOLS AND MECHANICS' AND ENGINEERS' TOOLS OF ALL KINDS. MONTGOMERY & Co., New York, N. Y. Filed March 3, 1896.

FULTON

Essential feature.—The word "FULTON," Used since Oct. 1, 1895.



DEPARTMENT OF  
**ADVICE AND CRITICISM**  
 ON  
**RETAIL JEWELERS' ADVERTISING.**

BY ALFRED MEYER.

[This department is absolutely free to every retail jeweler and optician. Forward for criticism your newspaper ads., booklets, catalogues, novelties, circulars, etc. Ask advice and offer suggestions. Replies in these columns are unbiased. Please make letters as brief as possible. Every letter and ad. sent will receive full attention, though the publication of the matter may sometimes be delayed a week or two. Address letters and other matters to 'The Jewelers' Circular Pub. Co., 189 Broadway, New York.]

PART XIV.

IN THE CIRCULAR of March 4th I criticised a coupon ticket scheme, devised by Chas. F. Gray, Dayton, O. That the writer analyzed the scheme to the satisfaction of Mr. Gray is evident by the following letter:

Allow me to assure you that I appreciate your kindly criticism of ad. sent you, and at the same time acknowledge the justness of same. Would be pleased to have your opinion of the two ads. enclosed.

Yours very truly,

C. F. GRAY.

Mr. Gray enclosed two ads., both on front cover pages of an advertising scheme called "Snap Shots at Current Events."

This is the better ad. of the two.

the coupons have in Mr. Gray's store. An ad. should answer every possible question a reader might ask regarding the points outlined in the ad.

The other ad. below cannot bring sales. This much regarding the ads.

I do not know how the west side merchants have made their scheme known to the entire Dayton public, nor do I know what this publication, "Snap Shots at Current Events" is, as I received only the title page; nor do I know the circulation of the book—where it has been distributed, what favor it has found, or by whom it has been received, whether it reached only west side residents, living nearest

have brought trade from every section of Dayton.

Some of the readers of THE CIRCULAR might infer that I am criticizing solely in favor of newspapers, but I will say that while

may consider the cost too high. Again he may hold to the opinion that the public will go down-town for everything. In this merchants possess altogether wrong ideas. The American people, with their experiences in late years, are becoming in general more saving. They must be, because they are not earning too much money; hence they are forced to trade only at those stores where they can obtain the best goods for the least money, whether it be in the large stores down-town, or in the smaller stores situated in their home districts.

Of course, I do not mean to convey the idea that an ad. will bring

HOLIDAY PRESENTS . .

A GOLD DOLLAR

found west of the river is as valuable as if found east of the river.

MORAL:

Learn my prices before buying any article in my line.

I not only claim to **Compete**, but can and will save money for my patrons. All I ask is a comparison of Goods and prices. I invite you to call and see my stock; by so doing you are under no obligation to purchase.

CHAS. F. GRAY,

The West Side Jeweler,

Booth Block, . . . 1018 West Third Street.



**FREE! FREE!** WATCHES, CLOCKS, JEWELRY, SILVERWARE, SPECTACLES.  
**ABSOLUTELY FREE! HOW?**

Simply by purchasing your goods from the following reliable West Side merchants and receiving from them coupons, which I will accept as cash for anything in my line of trade. Don't wait, but commence to day and call for coupons and get your Jewelry, Watches, Clocks, Silverware, Spectacles, FREE at

**CHAS. F. GRAY'S,** West Side BOOTH BLOCK, Jewelry Store, 1018 WEST THIRD STREET.

- COUPONS MAY BE HAD FROM THE FOLLOWING MERCHANTS:
- J. W. Booth, Groceries and Provisions, 1020 West Third Street.
  - Miss M. Murray, Millinery, 1016 West Third Street
  - S. B. Anderson, Dry Goods and Notions, 1142 West Third Street.
  - G. Gaessler, Shoe Store, 1145 West Third Street.
  - Chas. Francisco, Drugs, Cigars, etc., 1263 West Third Street.
  - Albert H. Schafer, Hardware, 1315 West Third Street.
  - G. Brost, Dry Goods, Notions, etc., 1050 West Washington Street.
  - Wm. C. Mason, Groceries and Provisions, Cor. Fifth and Sprague.

It is good for this reason: It offers good inducements; it endeavors, with the aid of other Dayton west side merchants, to keep the trade in their own district. The ad. is, however, too indefinitely worded, because it does not clearly state upon what amount of purchase coupons will be given by the merchants, and how much cash value

the merchant. The question arises: "Has Mr. Gray or any of the other eight merchants customers outside of their own business districts; and are the greater number of these reached by the publication?"

Inserted in the best circulated newspaper on the west side the above ad. would, without a doubt,

many of the advertising experts are in the habit of so doing, this is not the case with the writer. I favor a good ad. in any good, widely circulated medium, whether newspaper, booklet or other device. But no merchant is on the right track to increase his sales, unless he advertises in the widest circulated newspaper. When his trade has reached such proportions, that he finds that advertising pays him he may then venture into closely allied schemes.

Trash advertising schemes and mediums are plentiful. Only those advertisers are successful who avoid them; shrewd economic shoppers avoid them. What shoppers and the general public never tire of is a good newspaper.

I am certain that the majority of shoppers, for economy's sake, never throw a newspaper aside until they have read through the advertisements, compared them, and noted the bargains to be obtained.

Mr. Gray might not be in favor of newspaper advertising, because he may have never tried it, or he

good returns from every newspaper. The advertiser must with certainty know which newspaper has the largest circulation in his own business district.

My advice to Mr. Gray and others situated as he is, is to throw aside all trashy schemes, programmes, etc., and invest the same amount of money thus spent in the best daily newspaper circulating in his district, offering as good values as any of the down-town competitors, and making the ads. as attractive and forcible as can be produced. Of course the advertising must be handled judiciously.

If the advice given in this article is adhered to, Mr. Gray and others will find that at the end of the year their sales will have increased by a large per cent.

The money saved from "schemes" may be utilized for two purposes: For newspaper advertising, as indicated in this issue, and for improving the store front, store windows and window display. An attractive front and show window are profit-bringing.

# A JEWELER'S NECESSITY



— IS THE —

## "TRADE-MARKS OF THE JEWELRY AND KINDRED TRADES."

Copyright, 1896, by The Jewelers' Circular Pub. Co., 189 Broadway, New York.

For seven months THE JEWELERS' CIRCULAR has had under way a work that will comprise the trade-marks of every branch of the Jewelry, Watch, Clock, Silverware, Silver Plated Ware, Optical Goods, Precious Stone, Art Pottery, Bric-à-brac, Cut Glass and cognate lines of the Jewelry Industry.



The work is now nearing completion. We consider it will be the most valuable book that has ever been issued to the Jewelry trade.

It is a work which the retailer and wholesaler will immediately appreciate.

It will be a book of constant reference, and will be consulted more perhaps than any other book issued to the trade.

It will be a book of daily use.

It will be sold at a figure that will guarantee its rapid distribution.

In addition to illustrations of the various trade-marks and the names and the addresses of the firms to whom they belong, and the class of goods to which they appertain, the work will contain other interesting and valuable information bearing upon the subject of trade-marks.



Those firms who have as yet not sent electrotype, print or drawing of their trade-mark or trade-marks are requested to do so at the earliest possible moment.

Members of the Trade, Manufacturers, Wholesalers and Retailers should at once place their orders for

### "TRADE-MARKS OF THE JEWELRY AND KINDRED TRADES."

\$1 per copy. Bound in Cloth. Payable now or upon delivery of Book. Detach order below and forward to the Jewelers' Circular Publishing Co., 189 Broadway, New York.



#### ADVANCE ORDER BLANK.

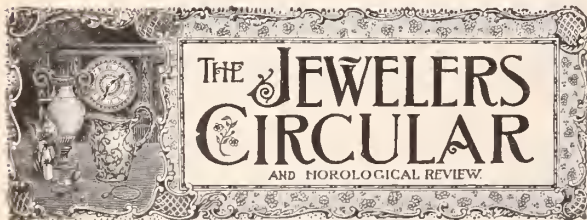

189 Broadway, New York.

..... 1896.

Please file this order for ..... copy of

"Trade-Marks of the Jewelry and Kindred Trades"

for which I agree to pay \$1.00 per copy, postage prepaid, upon delivery of book.

Name .....

Street..... City..... State.....

**Winding Lever for Regulators.**

THE following described arrangement for winding spring regulators, says G. H. Horsmans, of Maestricht, Holland, in *Deutsche Uhrmacher Zeitung*, has repeatedly been made by me, and, as it has without an exception proved to be both practical and convenient, I believe it may interest my fellow watch-makers.

Accompanying sketch shows the device in

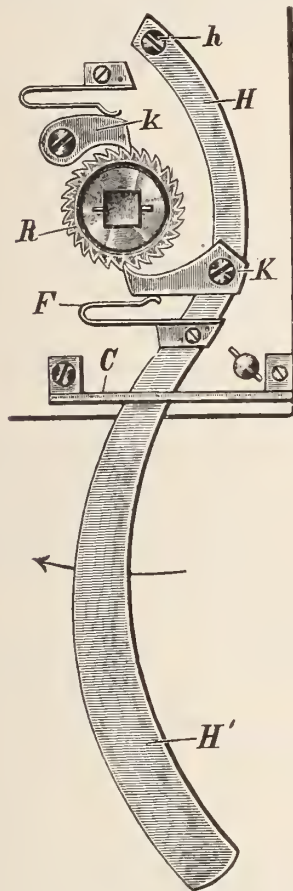

natural size; it is fastened to the running works; if the clock has a striking train, both trains must be furnished with the device. A glance at the illustration will show that the novelty consists principally of a movable lever with a pawl, which propels the ratchet wheel forward when the lever is actuated.  $H H^1$  is the winding lever, with revolving motion around the screw  $h$ , and receives a steady motion by the bridge  $C$  screwed at the lower edge of the plates; the two feet of the bridge form at the same time the limitation of the lever motion.

The click  $k$  must in this case lie above the barrel ratchet  $R$ . At the same height with the lower edge of the ratchet is screwed to the lever  $H$  the pawl  $K$ , which is constantly pressed into the teeth of the ratchet  $R$ . The lever  $H H^1$  is in the illustration shown in about its central position. When it is pushed to the left, in the direction of the arrow, the ratchet is wound by a few teeth. When drawn back to the right the pawl  $K$  passes empty over the ratchet teeth. By moving the lever  $H H^1$  to and fro the clock can naturally be wound in

a convenient manner. The sweep of the lever may be made so large that it actuates each time one-fifth or one-sixth of a turn.

As above stated, customers like the device, and I believe it is well adapted for accessory parts in factory-made clocks. The great advantage is, no key can get lost or wear out, and, considering the length of the lever, it is easy to wind a strong spring with it.

**Workshop Notes.**

**Cleaning Pinion Leaves.**—Take a pegwood and clean the leaves of the pinion. If you find any of them rusty, clean with pegwood and oilstone, powder and oil.

**Gold-Colored Lacquer.**—The following is a good recipe for a lacquer that will put a gold color on a copper plated work: One gallon methylic alcohol, ten ounces of bruised seed lac, and one-half ounce of red saunders wood; dissolve and strain.

**Oiling Roller Jewel.**—Some watchmakers recommend the oiling of the roller jewel. Never do this, as the roller in its flying motion (being sticky from oil) will gather up dust and other foreign substances, and soon clog in the fork, and besides this, it is perfectly superfluous, as it does not lessen the friction or improve the fork and jewel action.

**Waxed Paper.**—Paper saturated with wax, paraffine or stearine is very useful for wrapping up articles which should be kept dry and not exposed to the air. Place a sheet of stout paper on a heated iron plate, and over this place the sheets of unglazed paper—tissue paper does very well—that are to be waxed. In-close the wax or paraffine in a piece of muslin, and as it melts spread it evenly on the paper.

**Pallets.**—The clear space between the pallets should correspond with the outside measure on the points of three teeth of the scape wheel. The usual manner of measuring for new pallets is to set the wheel as closely as possible to free itself when in motion. It can be arranged in the depthing tool, after which the measurement between the pivot holes of the two pieces on the pillar plate will show exactly what is required.

**Silvering Articles.**—*La Science Francaise* publishes the following formulas for silver-plating copper by rubbing: I. Mix 15 parts Spanish white, 4 parts cyanide of potassium, 2 parts nitrate of silver. Pulverize finely. Apply by rubbing with a little water. This mixture is poisonous.—II. Mix 12 parts nitrate of silver, 50 parts marine salt, 50 parts cream of tartar. Rub on with a little water. This mixture is innocuous. For silver-plating by immersion or plunging, enter the scoured pieces in a boiling bath of bi-cyanide of potassium and silver containing 5 grains silver per liter.

**Lubricating Watch.**—Before putting the balance in, after having driven on the hairspring, oil the pivots of the train and balance wheel by putting on just about as much oil as will fill the oil sink in jewels or plates. After the balance is in and the watch in motion, oil the escape wheel teeth by letting it run

against your oiler, which should be charged with about as much oil as would be used on one pivot of the train. In a watch where the escape wheel is sunk in the plate, or otherwise, so that each tooth cannot be oiled, place the above mentioned amount of oil on the remaining pallet.

**Pin Tongue Rivet.**—Some workmen have the habit of forcing the rivet in tightly and then filing the ends smooth with the joint. This, of course, makes a clean job, but it causes a great deal of trouble to the workman who next has to repair it. When I get such a piece of work I take a pair of parallel pliers and press the joint where the rivet is tight, thereby, naturally, stretching the joint slightly; after this the rivet can be removed without damaging the article. Should it be impracticable to use pliers, I rub the parts affected with a burnisher. This is also applicable to case joints. I remove the plugs, ascertain where the joint pin is and burnish over the tight spot. I am careful, however, not to rub over the places where the plugs enter.

**To Silver Glass.**—Dissolve 3 grains of ammonical nitrate of silver in one ounce distilled water, which solution must be rendered somewhat clouded by sufficient nitrate of silver, and then filtered. Immediately before use mix one ounce of this solution with  $2\frac{1}{2}$  grains Rochelle salts. The glass to be silvered, having been cleaned to its utmost, is set in a suitable vessel, the bottom of which is provided with a few wax cones, thus raising the glass about one inch above the bottom, and the fluid is poured over it. The vessel is placed on the northern side of the house, or in a place with deadened light, and the silver precipitate will be sufficiently thick in two hours. It is taken out, washed, and dried; if the glass with the silver pellicle is to be used as reflector or speculum, the coating must be protected by varnish.

**New Electroplating Process.**—Some time ago it was announced in our English contemporaries that a new electroplating process was being introduced by the London Metallurgical Co. It was stated that the results were good, as the cost was less than that of silver, and the effects of silver and nickel-plating were absent; but as is usual with English processes, the principle was kept secret. It now appears that the electrolytically deposited coating consists of an alloy of silver and zinc. When it is desired to protect the silver from tarnishing, about 25 to 35 per cent. of zinc is sufficient, but a less costly coating may be produced by employing 40 to 50 per cent. of zinc. The bath is prepared by dissolving a suitable quantity of cyanide of zinc in a solution of cyanide of potassium so as to form a double salt with a small excess of the cyanide of potassium. This solution, with the addition of a small quantity of the double salt of cyanide of potassium and silver, forms the electrolyte, which is introduced into any suitable electroplating or electrotyping apparatus. The anode consists of an alloy of zinc and silver in the same, or approximately the same, proportions as are desired in the alloy to be deposited.



# New Roy 12 Size Waltham Cases. Now on the Market.

**S**YMMETRY, STRENGTH, BEAUTY OF FINISH, SWISS HEAD SPRINGS, GOLD DUST BANDS, EXTRA THIN.

These are points of excellence which, as a result of years of experience, we have been able to make the most of, in constructing these splendid cases. They are made for the finer class of trade, only. Leading jobbers handle Roy Solid Gold Cases. Look for this Trade-Mark in every case.



**ROY WATCH CASE CO.,** 21 Maiden Lane, N. Y.

## SLOAN & COMPANY,

SUCCEEDING

JOHN A. RILEY & SLOAN CO.,

**MANUFACTURING JEWELERS,**

23 MAIDEN LANE, N. Y.

HAYS BUILDING.

AUGUSTUS K. SLOAN, Pres.  
FRANK T. SLOAN, Vice-Pres.

BENNET OSBORN, JR., Treas.  
ALLAN A. McDONALD, Sec'y.

**NO SOLDER. NO SEAM.**

**SAVE TIME AND MONEY.**

Superior to Anything Ever Shown.  
Apply for Catalogue to

**CHAS. BACHEM,** 249-251 N. J. R. AVE.,  
NEWARK, N. J.  
Manufacturer of  
Marquise Heads, Clusters, Ring Shanks, Gypsy Rings, Etc.



## HENRY FERA,

IMPORTER AND CUTTER OF

# DIAMONDS

PRESCOTT BUILDING,  
65 Nassau St. cor. John NEW YORK.

FACTORY  
60 Fulton St., NEW YORK.

Cutting for the Trade a Specialty,

## ENAMELERS

OF GOLD, SILVER AND PLATED JEWELRY,

Enameled. Plain and in Colors.

ALSO OF

**SOCIETY EMBLEMS,  
YACHT AND COLLEGE FLAGS.**

All Varieties of Painted Enamel Work.

## S. S. WILD & SON,

179 Eddy Street, PROVIDENCE, R. I.

Correspondence Solicited.  
Telephone Connection.

## CROUCH & FITZGERALD.

Jewelry Trunks  
and Cases,



161  
Broadway,  
Bet. Cortlandt and  
Liberty Sts.,  
888 B'way,  
701 6th Ave.,  
NEW YORK.

## FERD. FUCHS & BROS. SILVERSMITHS.

MAKERS OF STERLING SILVERWARE,  
808-810 Greenwich St.. - New York.

## WOOD & HUGHES, STERLING SILVERWARE MANUFACTURERS

New York Agents for the Derby Silver Co.,  
**FINE QUADRUPLE PLATED WARE,**  
No. 16 JOHN STREET, NEW YORK  
206 Kearney St., San Francisco, Cal.  
HASKELL & MUEGGE, Agents.

## CAMPBELL-METOALF SILVER CO., SILVERSMITHS,



ALL GOODS 925/1000 FINE.  
Factory, Providence, R. I. Offices, New York and San Francisco.



## The Rambler's Notes.

WHAT THE RAMBLER SAW AND HEARD AMONG THE DEALERS IN ART POTTERY, CUT GLASS, BRONZES, ETC.

THE POPULARITY OF **O**NE of the most successful articles in crystal recently has been the crystal cigar jar. The fact that the properties of glass make it the best substance for preserving tobacco has been but one of many causes for the hold which these cigar jars have acquired on the buying public. The principal reason, outside the fact that glass jars are thoroughly air-tight, is that jars of glass are capable of showing the maximum of richness and beauty of effect. The assortment of cigar and tobacco jars carried by C. Dorffinger & Sons is one of the largest in the market. Not only are there many sizes, but each size is shown ornamented in a number of different ways in beaded glass and mirrored glass or with many beautiful cuttings.

NEW GOODS IN **O**NE of the most beautiful products yet shown in Victoria ware. Lazarus, Rosenfeld & Lehmann's Victoria ware has just been opened at the warerooms of the firm, 60 Murray St., New York. This new line is at present confined to table novelties, but the decoration will soon be shown in a full line of all the pieces made at the firm's Altröhlau factory. This decoration consists of a finely shaded cobalt with the usual gold scroll work, but the articles are further ornamented in the white panels by sprays of white violets. The principal novelties now include trays, cracker jars, syrup jugs, condensed milk jars, chop dishes, berry sets and a number of other small pieces heretofore shown almost exclusively in French china.

THE NEW PHOENIX LAMPS. **T**HE distinguishing features of the new rich lamps just introduced by the Phoenix Glass Co. may be said to be their deep, rich colors and combinations, and exquisite flower, fruit and head decorations. The globes, decorated in the same manner as the lamps, are larger than ever before, the greater number measuring about 14 inches in diameter. Among the most beautiful varieties shown at the company's New York salesrooms, 42 Murray St., New York, are the dark green and

brown lamps decorated with Rembrandt heads, the lamps with orchard treatment and those decorated in the old Chinese blue and white and Copenhagen styles.

THE BEAUTY OF **A** BEAUTIFUL new product of the year called Crown Rudolstadt is exhibited by L. Straus & Sons, 42-48 Warren St., New York, who control the product of the New York & Rudolstadt Pottery Co. Crown Rudolstadt has an earthenware of the same body base as Royal Bonn and similar potteries, and though made in the same style of pieces, is considered by many superior to the older potteries in its glaze, finish and decorations. A line of vases and other pieces with a Delft decoration is now shown by L. Straus & Sons in a large variety of shapes.

P. W. LEONARD'S **P.** H. LEONARD, importer of fine enlarged ware-rooms: china and pottery, 76 and 78 Reade St., New York, has just added to his present quarters, the four-story building at 177 Church St., which increases his floor space 25x50 on each story and gives him better facilities than ever before for showing the china lines which he imports especially for the jewelry trade. THE RAMBLER.

## A Beautiful Chalice.

**W**HAT is probably the handsomest chalice in any of the churches in New York city, has recently been completed by the Gorham Manufacturing Co., at their works in Providence, for the Roman Catholic Church of St. Ignatius, Rev. Father Prendegast, pastor. It is made of 18 k. gold, is nine and one-half inches in height, and contains over 400 precious stones in the settings.

Collections of old gold were taken up in the church for the making of the chalice, and the congregation gave freely of jewelry and precious stones. Many heirlooms and other valued articles of adornment were given to the pious cause, and a great part of the articles contained stones, some of which were of great value. These were all used in the manufacture of the chalice, which contains all the gold, except a few necessary scraps, and all the jewels contributed. The weight of the old gold collected was over 115 ounces,

or nearly 10 pounds Troy weight. This, with the stones contained therein, was given to the Gorham Manufacturing Co. and transformed into a most beautiful article of service, valued at between \$4,000 and \$5,000.

The bowl is plain, resting on a traceried calyx, richly chased. The knob and base are six foil, chased and jeweled, the lower part of the base being pierced. The six panels of the base are filled in with the following emblems: In front, a diamond cross, of large size and great beauty; immediately behind this is a sacred heart, with the four evangelists, two on either side. The pattern is of plain disc form, with the sacred monogram on the under side. The 400 precious stones in the chalice include diamonds, emeralds, opals and in fact all of the other precious stones used for personal jewelry. There is a lesson in this consecration of things designed for personal and adornment, to the most sacred of all uses which will make the chalice far more valuable than any rarity of material.

## THE FACTORY BELL.

**O** JOYOUS clang of the factory bell,  
Thy music through the air doth swell  
And quaver o'er Fox River till  
It dies away on green sloped hill;  
White Father Time with hour glass  
Doth mark the seasons as they pass,  
And listens he—grim sentinel—  
To joyous clang of factory bell.

O, mournful peal of factory bell,  
Thy cadence wove a mystic spell  
Thro' by-gone years—a score and ten—  
When graybeards now were brown haired then,  
The span of life thou oft hast tolled,  
For they that lay in churchyard mold;  
Ah, thou hast been a funeral knell,  
O, mournful peal of factory bell.

O, clangor of the factory bell,  
Methinks thy jocund notes foretell  
A sunburst through the misty haze,  
And swift return to happy days,  
When thou wilt welcome home again  
The hum of labor's sweet refrain;  
All fears subside, all doubts dispel,  
With clangor of the factory bell.

—Rockford, Ill., Republic.

The Geo. H. Corbett Co., Worcester, Mass., have introduced a novel scheme in the disposal of bicycles. Monday the firm placed in their window a "Decker" \$100 wheel. It was offered for \$100 and will be reduced \$1 a day until sold. The firm used this plan in selling watches last Winter with satisfactory results.

TARIFF DECISIONS AND CUSTOMS RULINGS.

Reported from Washington expressly to The Jewelers' Circular.

Re-appraisements of Invoices of Rough Diamonds.

The following re-appraisements have been made by the United States Board of General Appraisers, viz:  
 11,350. Importation of precious stones, uncut, from Coettermans-Henrichs Keck Co., Auvers, on Feb. 10, 1896, as follows: Rough diamonds, 108½ karats, entered at \$15,054, and advanced to \$15,826 per karat; rough diamonds, 108½ karats, entered at \$13,896, and advanced to \$14,668 per karat; rough diamonds, 100½ karats, entered at \$11.58 and advanced to \$12,352 per karat; rough diamonds, 60¾ karats, entered at \$12,738 and advanced to \$13,51 per karat; rough diamonds, 21½ karats, entered at \$9,264 and advanced to \$10,615 per karat.

**The Classification of Rhinestone Buttons.** The Collector of Customs at Chicago, Ill., has addressed a letter to the Treasury Department calling attention to the decision of the Board of General Appraisers on the protest of Marshall Field & Co. against the assessment of duty by the Collector on certain rhinestone buttons imported per *Westernland*, Oct. 29, 1895. The Collector submitted a report of the appraiser at Chicago, stating that it has been the practice at his port to classify such merchandise

as dutiable as buttons of glass, under paragraph 317, Act of 1894, which classification has been generally accepted by importers at his port, and therefore recommended an appeal from the decision of the Board, holding that the merchandise above referred to was properly dutiable at the rate of 25 per cent. *ad valorem*, under paragraph 351 as a manufacture of which paste is the component material of chief value.

By reference to the decision of the Board it appears that they describe the merchandise in question to be clusters of imitation diamonds, in the form of buttons, with metal shanks, which they find are not commercially known as buttons, and therefore dutiable as manufactures of which paste is the component material of chief value. The department holds that the merchandise in question is, in fact, buttons; that they are intended for and applied to the ordinary uses of buttons, and that the case will therefore warrant an appeal for review under the provisions of Section 15, of the Act of June 10, 1890. The Collector has been authorized to file such an application.

The demand for opals increases; up-to-date women don't care a fig for superstitions and make no effort to resist the extreme beauty of this stone.

Books of Interest.

**Repertoire chronologique** des principaux faits ayant contribué aux progrès de la chronométrie. [Chronological order of the principal facts having contributed to the progress of time-keeping]. From the year 700 before the Christian era to the present. Geneva, *Journal Suisse d'Horlogerie*. 8vo. pp. 8.

THE CIRCULAR is under obligations to its old and sterling exchange, the *Journal Suisse d'Horlogerie* for the copy of above little pamphlet, the pages of which speak of the patient research among the musty tomes, by the plodding student. The numerous dates of inventions, improvements, etc., are milestones to mark the progress made in horology on its road toward perfection. The first date is the sun dial of Achaz, king of Juda, 740 years before the Christian era, and the last, "L. Losier, of Geneva, publishes his inquiry into the theory of adjustment of watches," 1890 of our era. The author, however, forgot to mention one timepiece, an interesting account of which is given in Genesis i., 16, which requires neither watch-linker nor lubrication with fish or any other kind of oil. Beside this slight omission, THE CIRCULAR thinks the little pamphlet is about as correct as human research can make it.

Hall clocks, with oak or mahogany cases, and trimmed with bronze ornaments, are out in a variety of new and pleasing designs.

BAWO & DOTTER BULLETIN

HALL CLOCKS==CHIMING CLOCKS.



643 ENGRAVED ORNAMENTS RAISED FIGURES—DIAL #234

New Cases now ready—made of oak or mahogany—carved inlaid or trimmed with bronze ornaments—in a great variety of new and beautiful designs. All our cases are made in this country and the material, workmanship and finish is unequalled. **MOVEMENTS**—Elliot's automatic chimes, on musical bars or gongs—Elliot's gong chiming movements with 5 or 9 gongs, and with and without the 8 cup bells, etc.

English recoil and dead beat, hour and half strike, weight movements with beautiful dials.

B. & D.'s new weight movement.

A LARGER OR BETTER STOCK CANNOT BE FOUND.

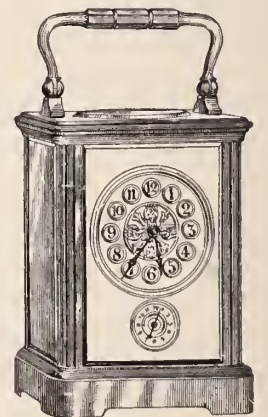

**TRAVELING CLOCKS.**  
 Large stock on hand.  
 Timers—Strikers—Repeaters—  
 ¼ Strikers.

BAWO & DOTTER, Manufacturers, Importers and Commission Merchants,

26, 28, 30 and 32 BARCLAY ST., NEW YORK.

# CARBORUNDUM

THE GREATEST ABRASIVE YET DISCOVERED.

Four times the Labor and Expense-saving qualities of Emery, Corundum or other abrasives. Adapted for Lapidary Work, Grinding, Polishing and every operation where a perfect abrasive is necessary.

Hones, Slabs, Files.

## Price List of Carborundum Wheels.

ACHESON'S PATENT, February 28th, 1893; February 26th, 1895.

DIAM. IN.	THICKNESS IN INCHES.																MAX. REV.
	1/8	3/8	1/2	5/8	3/4	1	1 1/4	1 1/2	1 3/4	2	2 1/4	2 1/2	2 3/4	3	3 1/2	4	
1	\$.15	\$.15	\$.20	\$.20	\$.20	\$.25	\$.30	\$.30	\$.35	\$.40	\$.40	\$.45	\$.50	\$.50	\$.60	\$.70	18000
1 1/2	.20	.25	.25	.25	.30	.30	.35	.40	.45	.50	.55	.60	.65	.70	.75	.85	14000
2	.20	.30	.30	.30	.35	.40	.45	.50	.55	.60	.60	.65	.70	.75	.85	90	11000
2 1/2	.25	.35	.40	.45	.50	.55	.65	.70	.80	.90	1.00	1.10	1.20	1.25	1.40	1.50	8800
3	.30	.45	.55	.60	.65	.75	.85	1.00	1.15	1.25	1.40	1.50	1.60	1.75	2.00	2.20	7400
3 1/2	.40	.50	.65	.70	.80	1.00	1.15	1.30	1.45	1.65	1.80	1.95	2.10	2.20	2.55	2.90	6300
4	.50	.60	.75	.85	1.00	1.20	1.40	1.60	1.80	2.00	2.20	2.40	2.60	2.80	3.20	3.60	5500
5	.70	.85	.95	1.15	1.25	1.60	1.95	2.30	2.60	3.00	3.30	3.65	3.95	4.25	4.90	5.55	4400
6	.95	1.10	1.30	1.55	1.75	2.20	2.70	3.15	3.60	4.10	4.55	5.00	5.45	5.90	6.80	7.70	3700
7	1.25	1.45	1.65	1.95	2.30	2.95	3.50	4.15	4.80	5.40	6.00	6.60	7.20	7.80	9.00	10.25	3160
8	1.50	1.70	2.00	2.40	2.80	3.60	4.40	5.20	6.00	6.75	7.55	8.30	9.10	9.90	11.45	13.00	2770
9	1.80	2.10	2.40	2.90	3.35	4.30	5.30	6.25	7.25	8.20	9.15	10.10	11.10	12.05	14.00	15.90	2460
10	2.15	2.60	2.85	3.45	4.00	5.15	6.30	7.45	8.60	9.75	10.90	12.00	13.20	14.35	16.60	18.90	2210
12	2.65	3.10	3.70	4.50	5.25	6.80	8.40	9.95	11.50	13.05	14.60	16.20	17.75	19.30	22.45	25.50	1550
14			5.05	6.05	7.00	9.00	11.00	13.00	15.00	16.95	18.95	20.95	22.95	24.90	28.90	32.80	1580
16					9.10	11.70	14.30	16.85	19.95	22.00	24.55	27.15	29.70	32.30	37.40	42.50	1380
18					11.25	14.45	17.70	21.00	24.25	27.50	30.75	34.00	37.25	40.50	47.00	53.50	1230
20						17.50	21.55	25.55	29.60	33.70	37.80	41.90	45.95	50.00	58.00	66.00	1100

CUT THIS OUT.

The wheels are made with a vitrified bond and pressed under hydraulic pressure. Those over three inches in diameter are turned up after firing. The same numbers are used to designate the degrees of fineness, as are used with Emery, and the wheels are made in seven degrees of hardness, marked SSS, SS, S, M, H, HH, HHH, from extremely soft to extremely hard. In ordering, state diameter, thickness, hole, number and hardness.

## THE CARBORUNDUM CO.

WORKS: MONONGAHELA, PA., AND NIAGARA FALLS, N. Y.

### THE SWAN FOUNTAIN PEN

Reputation World Wide.  
Made upon Distinct Principles.  
Is a Compressed Air Pump.  
Simply Wet the Insides to Provoke  
an Energy.

W. W. Stewart. Inventor and Patentee

A variety of Styles and Prices

- 3 Sizes Safety Swans.
- 3 Sizes Self-filling Swans.
- 3 Sizes Adjustable Swans.

MABIE, TODD & BARD,  
NEW YORK AND LONDON.

## AMERICAN WATCH TOOL CO.

ESTABLISHED 1872.  
INCORPORATED 1894.



THE  
**Webster-Whitcomb**

GROWS IN POPULARITY

PRICES AS LOW AS CONSISTENT WITH QUALITY.

Ask your Jobber for Price List of 1895, or write to us at

Stoney-Batter Works, Chymistry Dist., Waltham, Mass.

### AIKIN, LAMBERT & CO.,

MANUFACTURERS OF

FINE GOLD PENS, HOLDERS, PENCILS,  
TOOTH PICKS, and NOVELTIES.

PAUL E. WIRT FOUNTAIN PENS, at new and lower prices . . .  
MERCANTILE FOUNTAIN PENS, guaranteed to give satisfaction.

Catalogues with terms and discounts furnished to the trade.

BRANCH, 103 STATE STREET, - - - CHICAGO.

### AIKIN-LAMBERT JEWELRY CO.,

IMPORTERS OF

**DIAMONDS.**

JOBBERS IN

WATCHES, JEWELRY, CHAINS  
NOVELTIES, ETC.

LATEST DESIGNS.

LOWEST PRICES

19 MAIDEN LANE, NEW YORK.



**CYCLING PROGRESS  
EXEMPLIFIED.**

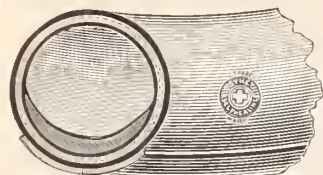

**THE WONDERFUL  
SELF-HEALING TIRES**

are single tube, finest rubber, finest wove Sea Island cotton fibre, re-enforced inside and outside on tread, and no better tire can possibly be made. They are fully guaranteed against all climatic changes, are the most resilient ever made, and when punctured instantly heal the wound of their own volition.

THEY WEIGH NO MORE THAN OTHERS,  
COST NO MORE,  
AND ARE WORTH TEN TIMES MORE.

—SEND FOR TIRE BOOKLET.—  
**Wm. H. CAHN, GENERAL MANAGER,**  
48 and 50 Maiden Lane, New York.

**BY EVERY TEST THEY ARE THE BEST.  
THE UNIVERSAL FAVORITES.**



**SUPERB  
Olympic  
BICYCLES**

For sale by more than 2,000  
Jewelers, and constructed to meet  
the demand for finest quality.

For Adults and Juveniles.

**SEND FOR EXQUISITE  
CATALOGUE.**

Top Grade "Olympics" have **SELF-  
HEALING TIRES.**

Olympic Cycle Mfg. Co.,  
N. Y. Office: 35 LIBERTY STREET.

**General Jobbing Ag'ts, S. F. MYERS & CO.,**  
WHOLESALE JEWELERS, Myer's Building, New York

**CHAS. JACQUES**

**CLOCK  
CO.,**

**22 Cortlandt St.  
NEW YORK.**



Hall Clocks,  
Traveling Clocks,  
Gilt Clocks,  
Porcelain Clocks,  
Delft Clocks,  
Mantel Chime  
Clocks,  
Bronzes,  
Sevres Vases.

**BAWO & DOTTER,**

**26-32 BARCLAY ST.,**

**NEW YORK.**

P. O. Box 1872.



**NO LARGER STOCK  
OF**

**HALL  
CLOCKS**

IS SHOWN IN  
THIS CITY.

Large Stock  
OF  
MOVEMENTS.

**NEW DESIGNS  
IN CASES.**

**STERLING**

Sheet and Wire Supplied. All Sizes.

**J. SCHAWEL & CO.,**

Gold, Silver and Platinum Refiners,

**29 JOHN STREET, NEW YORK.**

**PHILIP BISSINGER & CO.,**

IMPORTERS OF

**PRECIOUS STONES, PEARLS, CORALS and GARNETS,**

ANNOUNCE THEIR

**REMOVAL**

FROM 22 TO

20 JOHN ST., N. Y.



**44 YEARS OF  
HONEST RETURNS**

IS OUR GUARANTEE OF SATISFACTION  
TO ALL OUR CUSTOMERS.

WE DO OUR OWN SMELTING,

**JOHN AUSTIN & SON,**

ASSAYERS, REFINERS AND SMELTERS,

74 & 76 Clifford St., Providence, R. I.

**SECURITY PIN GUARD**

PAT'D DEC. 25, 1894  
MANFD BY SECURITY MFG CO. **25¢**

**7 ASTOR HOUSE (BROADWAY) N.Y.**

85c. doz. Net Cash. Discount to Jobbers

**JACOT & SON,**

Importers and Manufacturers of

**Musical Boxes,**

39 Union Square, New York.

- - EMMONS - -

**ASSOCIATED LAW OFFICES.**

PORTLAND, OREGON. SEATTLE, WASH. TACOMA, WASH.

Foreign Business a Specialty.

**QUICK SELLERS.....**

IN STERLING SILVER  
ARE MADE BY

**CODDING BROS. & HEILBORN,**

North Attleboro, Mass.

**DUBOIS WATCH CASE CO.**



REGISTERED.

**FINE HAND MADE  
SOLID GOLD CASES.**

A PRIDE TO THE MAKER,  
DEALER & WEARER.

**WE WILL CONTINUE TO MANUFACTURE**

Our Fine Mountings at our present location, No. 11 Maiden Lane, New York, till May 1st, 1897 when the buildings are to be removed.

**HENRY E. OPPENHEIMER & CO,** OFFICE: 14 MAIDEN LANE, NEW YORK.

**DIAMONDS** Importers and Cutters. **L. & M. KAHN & CO.,** 172 Broadway, **DIAMONDS**  
Cor. Maiden Lane, N. Y.



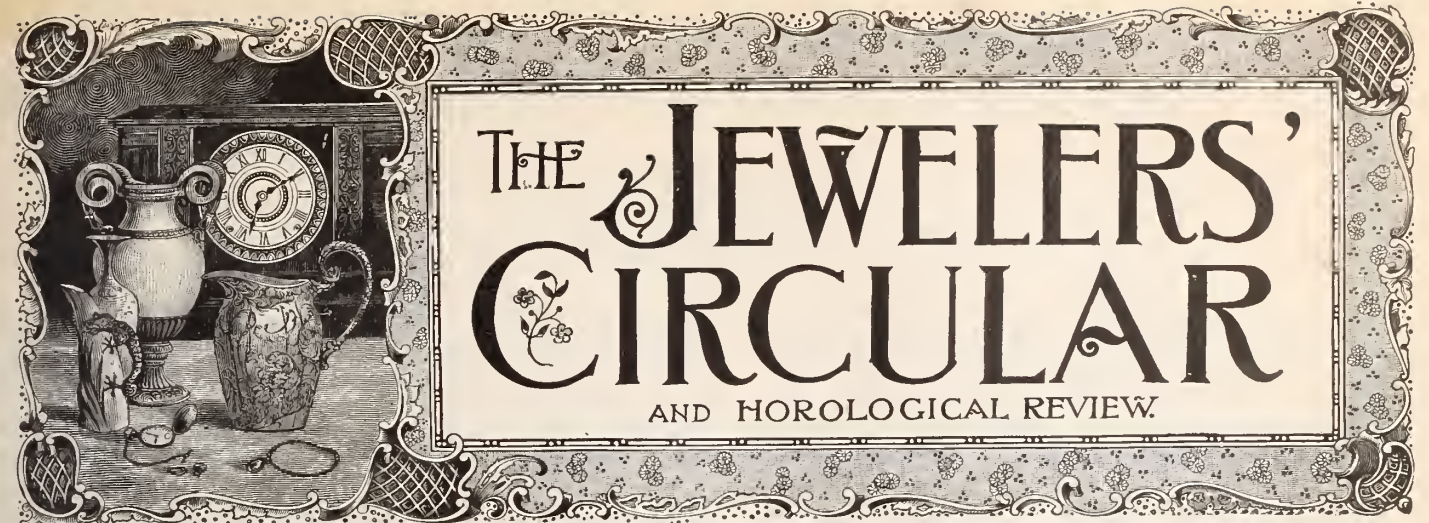

Copyright by THE JEWELERS' CIRCULAR PUB. Co.

189 Broadway, New York.

Entered at the Post Office in N. Y. as second-class matter

VOL. XXXII.

NEW YORK, WEDNESDAY, MAY 27, 1896.

No. 17.

## ARTISTIC DEVELOPMENT OF THE SPORTS TROPHY.

A BEAUTIFUL prize trophy has just been made by Theo. B. Starr, Madison Square, New York, upon the order of Hiram Walker, of Walkerville, Ont., one of the most generous patrons of sports and athletics in America. The illustration herewith, reproduced from a photograph showing the trophy in full size, can hardly do justice to the beauty of the work in the original. The prize proper consists of a vase, seven and a half inches high, made of 18k. gold, 300 pwt. of gold being utilized in its construction. The vase is perfectly Grecian in its details. The Greek fret rim and border around the square base and the treatment of the acanthus forming the principal ornamentation on the body of the vase are thoroughly in keeping with the outlines, producing a work of extreme delicacy and beauty. The words, The Walker Cup, are cut out and applied, while the other ornamental details are in fine chased work. The gold vase rests upon a cube of fine green onyx which in turn rests upon a rosewood base, upon the front of which is applied a silver panel bearing the presentation inscription. On the remaining three sides of the rosewood base are 10 silver plates bordered with laurel wreaths, in which from year to year the name of the winning club will be engraved. Enclosing the gold vase and onyx stand, is a fine glass case, nine and a half inches wide by twelve inches high, which is so delicately and perfectly made that no moulding is visible.

wood base with its mountings of silver panels, produce a play of color that is marvelously rich

as to be in perfect harmony with each other; while the general feeling of severity is in keeping with the ancient Greek style so admirably adopted. The cost of the entire work was about \$1,100.



CURLING PRIZE OFFERED BY HIRAM WALKER WALKERVILLE, CANADA.

## Making a Good Drill.

IF we wish to make a drill that will act to satisfaction, we must be particular about getting the point exactly in the center; but this is just what is often neglected. Now, it will not be difficult for the youngest reader to understand that when the point is out of center, one side of that point has to cut a larger shave of the metal under operation than the other does; hence, the side that is cutting its smallest shave does not do all it might and could do, if working under different circumstances. This, of course, is detrimental to the speedy action of the drill, and if the reader would verify this statement, he should make two drills alike in every respect, except that one should have its point central, while the other should not—both must be tempered alike. Then let him drill through a sheet of brass and notice the time it takes in each case, when he will find that the result will be considerably in favor of the centrally pointed drill.

The yellow color of the gold, the green of the onyx stand, the reddish brown of the rose-

and beautiful. The whole work, gold cup, onyx stand and rosewood base are so designed

Jeweled effects are more and more in evidence, as the season advances, on dresses and hats, which are enriched with trimmings richly studded with gems or semi-precious stones.

# WE MAKE THE FINEST STYLES

OF STERLING SILVER BUCKLES MOUNTED IN  
LEATHER OR SILK WEBBING.

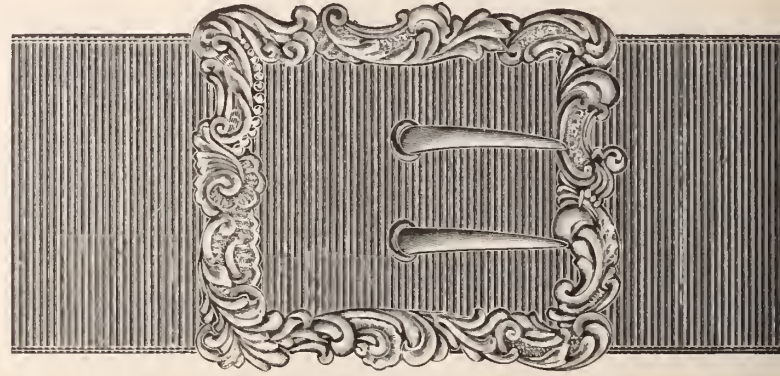
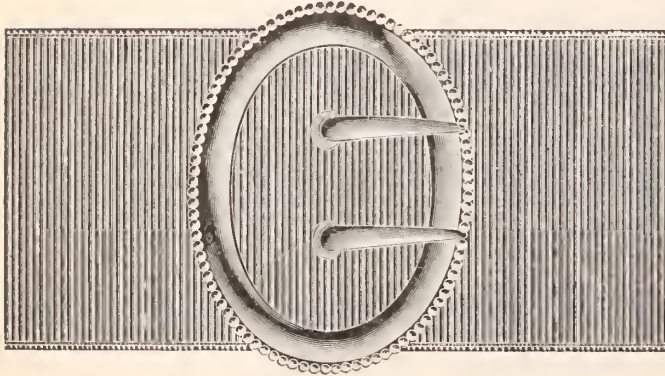

NEW YORK OFFICE:  
21 & 23 MAIDEN LANE.



BOSTON OFFICE:  
403 WASHINGTON ST.

## KENT & STANLEY CO., LTD.

PROVIDENCE, R. I.

WM. SMITH & CO., 5 and 7 MAIDEN LANE, NEW YORK.  
61 PECK ST., PROVIDENCE, R. I.

CAMPBELL-METOALF SILVER CO.,  
SILVERSMITHS,

ESTABLISHED  
1854.



MANUFACTURERS  
OF

Gold, Silver and Rolled Plate Chains and Jewelry.

Novelties in Gold and Silver Bead Necklaces and Bracelets. Also a large line of Chain Trimmings and Silver Rings.



ALL GOODS 925/1000 FINE.

Factory, Providence, R. I. Offices, New York and San Francisco.

DON'T FORGET THE JEWELERS' CIRCULAR PUBLISHING CO.'S BOOK LIST when in want of any technical book in the Jewelry or Kindred Trades.

# “Apparel oft proclaims the man.”



CHOICE PAPERS

So with our fine note papers, envelopes and papeteries—all our bands, boxes and labels are neat, tasty and artistic and perfectly in keeping with and a credit to the high grade goods with which they are used. Our fashionable stationery is put up in a manner that appeals to people of refined tastes, and it is a line particularly adapted for jewelers. We **do not** sell to dry goods or department stores. Write for samples.

**PARSONS & GREENE CO.,**  
MANUFACTURING STATIONERS,  
HOLYOKE, MASS.



**Sterling Silver**  
 1 in. \$12.00 doz.  
 1 1/4 in. 13 50 “  
 1 1/2 in. 15.00 “

AND UPWARDS.

**SILVER PLATE, 3 Sizes.**  
 \$24.00 per Gross, assorted.

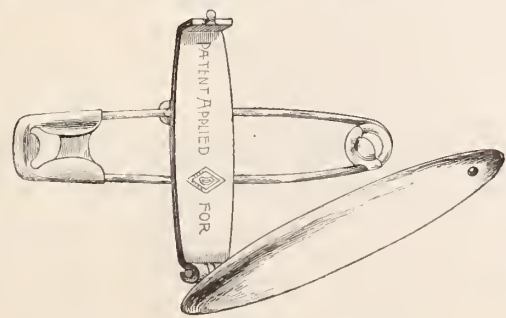

**DEITSCH BROTHERS, MAKERS.** 7 East 17th St., NEW YORK.



# Standard Sterling Silver Goods.

**Belts,**  
 LEATHER, GILT,  
 SILVER AND  
 SILK WEBBING.

**Waist Sets,  
 Sleeve Links,  
 Hat Pins,**  
 IN  
**Sterling Silver  
 AND  
 Rolled Gold Plate.**

600 Useful Articles  
 IN  
**Sterling Silver.**



**Foster & Bailey,**  
 Providence, R. I.

NEW YORK, CHICAGO,  
 SAMPLES ONLY. SAMPLES ONLY.

### An Odd Corsage Garniture.

**A** CURIOUS piece of jewelry was recently made by J. H. Johnston & Co., 17 Union

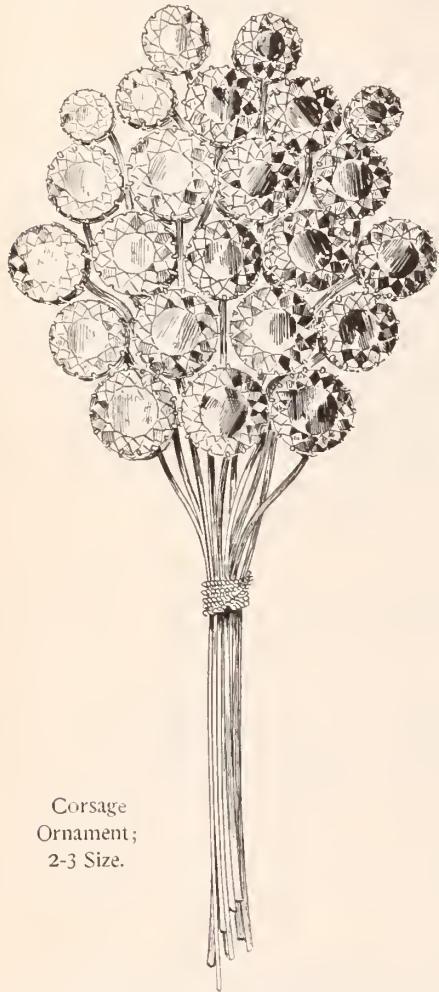

Corsage  
Ornament;  
2-3 Size.

Sq., New York, for one of their customers, to

whom they have at different times furnished expensive gem jewelry. The jewel is a corsage ornament, of which an illustration two-thirds the original size is here presented. It consists of 23 large and fine amethysts set on silver gilt stems enameled in green, these stems being tied with a piece of silver wire simulating cord. As may be seen by the illustration, the stones are symmetrically arranged.

### Precious Stones and Jewelry Not Included in this Bill.

WASHINGTON, D. C., May 21.—The House Committee on Ways and Means has decided to report favorably the bill to permit customs officials to deliver packages not exceeding \$500 in value to express companies and other inland carriers under bond after appraisal on the wharves. Jewelry and precious stones are excepted.

### Death of an Old-Time Boston Jeweler.

BOSTON, Mass., May 20.—John N. Chapman, an old-time business man of Boston, who for many years has lived in Brookline, died at his residence May 8th in his 67th year. The cause of his death was fatty degeneration of the heart and paralysis of the brain.

John N. Chapman was born in Meredith, N. H., Aug. 22, 1829. He came to Boston at the age of 12 years and entered the jewelry store of the old firm of Jones, Ball, Poor & Co. to learn the business. He later was a salesman for Bigelow, Kennard & Co., and left them, in 1854, to engage in business for himself under the firm name of Bailey, Kittell & Chapman, at the corner of Broomfield and Washington Sts., Boston. Later in life he was the agent for the Boston and Sandwich (Cape Cod), and the Western glass companies. In 1855 he married Hannah H., the

daughter of the late Luther Dana, of Newton, and had five children, two sons and three daughters.

During the last few years of his life he gave up all active business, largely on account of the heart trouble with which he was afflicted, and which finally caused his death.

### Returns of Connecticut Silver Plate and Clock Corporations.

NEW HAVEN, Conn., May 21.—Among the corporation returns just announced are the following:

Silver City Plate Co., Meriden, capital \$5,000, real estate none, personal estate \$4,626, debts \$1,549, credits \$4,000.

Rogers Cutlery Co., Hartford, capital \$25,000, real estate none, personal estate \$174,266, debts \$108,908, credits \$77,023.

Wm. Rogers Mfg. Co., Hartford, capital \$25,000, real estate none, personal estate \$174,266, debts \$108,908, credits \$77,023.

Meriden Silver Plate Co., capital \$200,000, real estate \$72,186, personal estate \$247,566, debts \$72,240, credits \$83,176.

Ansonia Clock Co., capital \$1,000,000, real estate \$125,000, personal estate \$545,000, debts none, credits \$330,000.

Ansonia Brass and Copper Co., capital \$1,500,000, real estate \$500,000, personal estate \$1,220,000, debts \$350,000, credits \$230,000.

Winsted Optical Co., capital \$45,000, real estate none, personal estate \$27,815, debts \$15,478, credits \$28,315.

Maltby, Stevens & Curtiss Co., Wallingford, capital \$125,000, real estate \$58,000, personal estate \$193,000, debts \$124,500, credits \$9,800.

# Dorflinger's American Cut Glass.

DEALERS SHOULD  
PREPARE FOR

JUNE WEDDINGS.

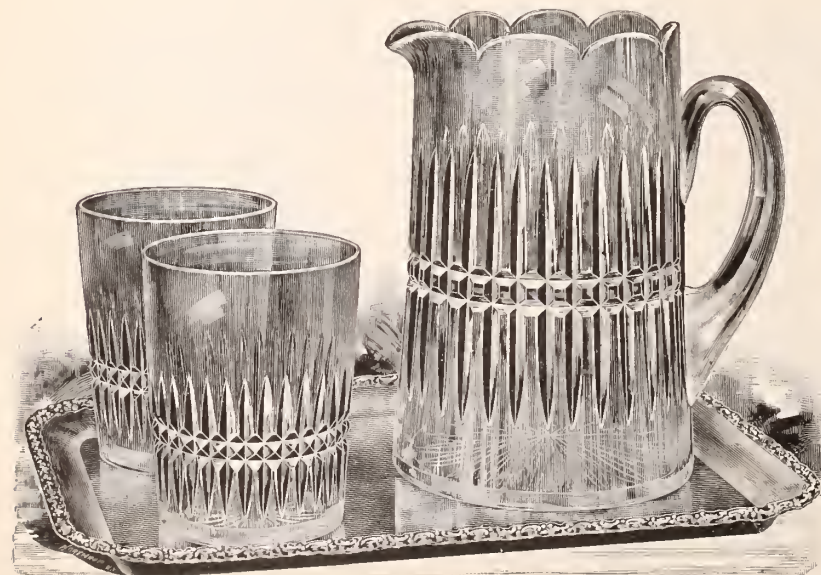

WATER SET.

**C. Dorflinger & Sons,**

36 MURRAY STREET,  
915 BROADWAY,

NEW YORK.

# TWO NEW PIECES FOR

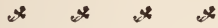

Where would we be if in a quiet season we decided to make **nothing new** till we saw a **demand**?



No. 2846. HAND MIRROR.

# EVERY DAY IN THE YEAR.

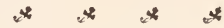

Make the **demand**. Sort up your stock with 25, 50 or 100 new pieces that will make people buy. We furnish goods that sell.



No. 6607. BON-BON DISH.



No. 1969. TRINKET TRAY.

FACTORIES,  
NEW BEDFORD MASS.

SALESROOMS,  
NEW YORK. CHICAGO.  
SAN FRANCISCO. MONTREAL.

## PAIRPOINT MFG. COMPANY.

# CARBORUNDUM

THE GREATEST ABRASIVE YET DISCOVERED.

Four times the Labor and Expense-saving qualities of Emery, Corundum or other abrasives. Adapted for Lapidary Work, Grinding, Polishing and every operation where a perfect abrasive is necessary

### Price List of Carborundum Wheels.

ACHESON'S PATENT, February 28th, 1893; February 26th, 1895.

DIAM. IN.	THICKNESS IN INCHES.																MAX. REV.
	1/4	3/8	1/2	5/8	3/4	1	1 1/4	1 1/2	1 3/4	2	2 1/4	2 1/2	2 3/4	3	3 1/2	4	
1	\$.15	\$.15	\$.20	\$.20	\$.20	\$.25	\$.30	\$.30	\$.35	\$.40	\$.40	\$.45	\$.50	\$.50	\$.60	\$.70	18000
1 1/2	.20	.25	.25	.25	.30	.30	.35	.40	.40	.45	.50	.55	.55	.60	.70	.75	14000
2	.20	.30	.30	.30	.35	.40	.45	.50	.55	.60	.60	.65	.70	.75	.85	.90	11000
2 1/2	.25	.35	.40	.45	.50	.55	.65	.70	.80	.90	1.00	1.10	1.20	1.25	1.40	1.50	8800
3	.30	.45	.55	.60	.65	.75	.85	1.00	1.15	1.25	1.40	1.50	1.60	1.75	2.00	2.20	7400
3 1/2	.40	.50	.65	.70	.80	1.00	1.15	1.30	1.45	1.65	1.80	1.95	2.10	2.20	2.55	2.90	6300
4	.50	.60	.75	.85	1.00	1.20	1.40	1.60	1.80	2.00	2.20	2.40	2.60	2.80	3.20	3.60	5500
5	.70	.85	.95	1.15	1.25	1.60	1.95	2.30	2.60	3.00	3.30	3.65	3.95	4.25	4.90	5.55	4400
6	.95	1.10	1.30	1.55	1.75	2.20	2.70	3.15	3.60	4.10	4.55	5.00	5.45	5.90	6.80	7.70	3700
7	1.25	1.45	1.65	1.95	2.30	2.95	3.50	4.15	4.80	5.40	6.00	6.60	7.20	7.80	9.00	10.25	3160
8	1.50	1.70	2.00	2.40	2.80	3.60	4.40	5.20	6.00	6.75	7.55	8.30	9.10	9.90	11.45	13.00	2770
9	1.80	2.10	2.40	2.90	3.35	4.30	5.30	6.25	7.25	8.20	9.15	10.10	11.10	12.05	14.00	15.90	2460
10	2.15	2.50	2.85	3.45	4.00	5.15	6.30	7.45	8.60	9.75	10.90	12.00	13.20	14.35	16.60	18.90	2210
12	2.65	3.10	3.70	4.50	5.25	6.80	8.40	9.95	11.50	13.05	14.60	16.20	17.75	19.30	22.45	25.50	1850
14			5.05	6.05	7.00	9.00	11.00	13.00	15.00	16.95	18.95	20.95	22.95	24.90	28.90	32.80	1580
16					9.10	11.70	14.30	16.85	19.95	22.00	24.55	27.15	29.70	32.30	37.40	42.50	1380
18					14.45	17.70	21.00	24.25	27.50	30.75	34.00	37.25	40.50	47.00	53.50	1230	
20					17.50	21.55	25.55	29.60	33.70	37.80	41.90	45.95	50.00	58.00	66.00	1100	

The wheels are made with a vitrified bond and pressed under hydraulic pressure. Those over three inches in diameter are turned up after firing. The same numbers are used to designate the degrees of fineness, as are used with Emery, and the wheels are made in seven degrees of hardness, marked SSS, SS, S, M, H, HH, HHH, from extremely soft to extremely hard. In ordering, state diameter, thickness, hole, number and hardness.

Hones, Slabs, Files.

CUT THIS OUT.

## THE CARBORUNDUM CO.

WORKS: MONONGAHELA, PA., AND NIAGARA FALLS, N. Y.

## THE BICYCLE AS A JEWELER'S SIDE LINE.

Jewelers' Experiences in the Handling of Bicycles—Sales and Makes of Wheels Handled—Prospects for the Future.

### PART II.

It has been generally conceded, without much question, that the bicycle has become an intimate and profitable adjunct of the jewelry business. It is now the proper time to learn how much positive truth there is in this supposition, and it was with this purpose in view that a letter was addressed to the correspondents of THE CIRCULAR located at various points throughout the United States, embodying the following questions:

*We would like you to send us about 200 words as to the extent to which the jewelers of your city are handling bicycles.*

*The names of the bicycles which the principal jewelers are handling.*

*Some calculation as to the number that are being sold monthly.*

*Prospects for the future in the sales by the Jewelers.*

*How long the jewelers expect bicycles to form part of their stock.*

*Include in your article other points bearing on the subject that may crop up in your investigations.*

The opinions expressed in the replies received are unbiased, and are dictated by the facts that have come within the range of the correspondents' investigations.

#### PITTSBURGH, PA.

PITTSBURGH, Pa., May 12.—The bicycle business among the jewelers in Pittsburgh, Pa., is comparatively a new one, but two leading firms being as yet possessed of sufficient temerity to take hold of the article. The rate, however, at which these two firms are getting rid of two high-grade wheels at a strictly cash basis, should be encouragement for the rest to enter the race. The jewelers, in the main, hesitate on the grounds that factories cannot meet the demand; that people will not pay money for wheels and then be obliged to wait an indefinite time for their appearance.

West, White & Hartman have had the "Dueber Special" for the past four weeks, and sold 13 in two days. They have established agencies in all sections of the city, in Burgettstown, Dawson Station, and Kittanning. George W. Biggs & Co. are agents for the "Dueber" in the lower part of the city. Mr. Hartman anticipates an enormous sale of wheels up to July 1st, after scholars arrive home from school, and beyond that time a good trade. Bicycles will remain a part of their stock so long as the public ride. The "Elgin King" is the wheel found in the G. B. Barrett & Co.'s stores, and the department is in charge of Mr. Harrison, who has found the sale to be beyond expectation. The "Elgin" is made by the Elgin Cycle Co., Elgin, Ill. Mr. Harrison computes the average sale at 50 a month, and estimates the rush of trade to ex-

tend to July 1. Goddard, Hill & Co. had intended carrying a well known wheel, but the unsatisfactory rate of supply deterred them from embarking in the bicycle trade so far. Notwithstanding a surplus of bad roads, Pittsburgh has developed into a great cycling town, and judging from the report of the two above mentioned reliable firms, every wholesaler in the city next season will have a bicycle department.

#### SPRINGFIELD, MASS.

SPRINGFIELD, Mass., May 13.—Fred. A. Hubbard is the only Springfield jeweler engaged in the sale of bicycles, but he keeps his different lines of business separate and distinct. He handles the "Columbia" and "Hartford" wheels, and though he has had the agency for less than a year, has already sold about three times as many as were sold here all last season. He did not feel free to give the exact number but said that the business was very much more successful than he expected. Mr. Hubbard is of the opinion that for the next five years at least jewelers will go into the bicycle trade quite extensively. He argues that city jewelers should keep their stocks separate, inasmuch as a bicycle wareroom requires a workshop where wheels may be repaired. In pursuance of this policy he engaged a separate store and now has seven men at work in the various departments. He believes that country jewelers can with more propriety join their stocks, but even they must be prepared to do repairing. There is another point to which he calls attention which may be of some help to jewelers intending to embark in the business of bicycle selling: He warns them that they must prepare themselves, beginning on Jan. 1st of each year, for just such a rush as they experience in the jewelry trade during the Christmas holidays.

#### CINCINNATI, O.

CINCINNATI, O., May 15.—Where there were about half a dozen stores in Cincinnati last year selling bicycles, there are now 50 or more. This includes some of the jewelers who are making an experiment in this line. Mr. Anderson, manager of the cycle department of the Duhme Co., says there is no reason why the jeweler should not adopt this line; it is a Summer product, and that is the time the jeweler needs a live line; his business is dull and the cycle just fills the niche. Only two jewelers have branched out with salesrooms, while several others are merely agents with a single sample.

The Duhme Co. handle five wheels, the "Howard," "Dueber," "Elgin," "Welling-ton" and "Humber." This house sold in the

first three weeks of their opening of their salesroom, 35 wheels; they have made a steady increase, and now since they have taken the sole agency for the English wheel, "Humber," they expect to increase their sales.

A. & J. Plaut carry a line of "Elgin" wheels and a Cincinnati wheel, "Pegasus," and have sold 10 in a week. Mr. Plaut expresses the opinion that the wheel has come to stay as a Summer article in the jeweler's stock and in another year every enterprising jeweler in the city or country will find it to his advantage to handle it. John P. Shimp, special agent of the Dueber wheel, was in Cincinnati a few days ago and gave as his version of the outlook for the trade at large that the wheel was fast becoming popular with the jewelers throughout the country as a long felt want. They have found that they can sell wheels in Summer when they cannot sell watches, and some of their best agents are jewelers. The company's sales have exceeded their output and there are still jewelers all over the west who want the agency. The jewelry trade has never been, at its best, a very profitable business in Summer and the mercantile people of to-day are too active to waste from four to six months in waiting for trade to pick up; they must have a product for every season, and the jewelers long ago realized that the Fall months only have lately been productive.

L. M. Prince, optician, has a salesroom on 4th St., and handles the "Falcon."

#### PHILADELPHIA, PA.

PHILADELPHIA, Pa., May 24.—The bicycle trade has not obtained a lodgment among the jewelry houses of this city, and it is very improbable that it ever will. Philadelphia in many respects is the most conservative town in the country so far as the jewelry trade is concerned, and although refreshed efforts have been made to introduce cycling lines among the leading houses, these attempts have been uniformly unsuccessful. It is possible that some obscure jeweler in a remote local district may sell wheels but no such instance is known to the trade. The E. Howard Watch & Clock Co. did try hard to induce leading dealers to take up a line of bicycles, and at one stage Louis P. White thought of taking the agency, but the project was abandoned. The jewelry trade does not even handle cyclometers, although these are a direct product of the watch and clock making interest. One house that a year ago purchased a dozen cyclometers sold four, four were given away and four are still in stock. Every other branch of current trade may handle bicycles, but it is very evident that in Philadelphia the jewelers will have none of it.

#### KANSAS CITY, MO.

KANSAS CITY, Mo., May 12.—The jewelers of Kansas City have not taken up bicycles as a side issue to the extent that dealers in the surrounding towns have done; in fact only one firm handles them at all. Cady & Olmstead carry the "Howard" wheels, and did a

very successful business with them, having more orders than they could fill, but on April 15, on moving to new quarters, they were compelled to give up the agency, for want of room. It seems to be a general impression among all jewelers in the city, that a bicycle business takes more room than a jewelry store can well give to it, and also that when a wheel needs repairs it is inconvenient for it to be taken through a store crowded with well dressed customers. While in Kansas City itself there are now no jewelers handling wheels, jewelers of the surrounding towns make up for it, and claim they have good returns from them. Geo. Powell, Fort Scott, Kan., carries a full line of wheels in his jewelry store, and is himself a trick rider.

The following jewelers in the surrounding country carry wheels: L. G. Goodspeed, Colorado Springs, Colo.; D. D. Williams & Co., Emporia, Kan.; Geo. Hudson, Winfield, Kan.; D. L. Hagen, Newton, Kan.; Gene M. Thomas, Kirksville, Mo.; C. M. Harrington, Kirksville, Mo.; S. Sutter, Russell, Kan.; Boyle Bros., Louisburgh, Kan.; Geo. Porth, Jefferson City, Mo.; Theo. Burkhardt, Jefferson City, Mo. All of these jewelers are well pleased with their trade and will carry them as long as the season remains open, and will probably push them more next year.

**BOSTON, MASS.**

Boston, Mass., May 10.—The bicycle business has not attained the prominence in the jewelry trade of this city that is reported by the jewelers in some other sections of the country. Smith, Patterson & Co. are the only jobbers who have gone into the business extensively, and they handle the "New Haven," "Monarch," "Chicopee" and "Bostonian" wheels, the latter bearing their own trademark. The E. Howard Watch & Clock Co., however, have joined the ranks of the prominent bicycle manufacturers of the United States, turning out a wheel which ranks among the first class models of 1896.

Throughout New England, in the smaller cities and towns, the retail jewelers have taken up the bicycle business more widely, but there is no lack of stores devoted exclusively to bicycles in the Hub and its suburbs, so the jewelers here who have been identified with

the trade in wheels are few in number. Wilson Bros. put a wheel on the market last year, which they continue to carry, known as the "Rapid Transit"; and Kattelle Bros., their near neighbors, handle the "Howard" wheel. The other prominent city retailers have not, as a rule, given any heed to the movement to add bicycles to the stock in trade of the retail jeweler.

**SPRINGFIELD, ILL.**

SPRINGFIELD, Ill., May 10.—The bicycle business in Springfield, Ill., is not carried on by the jewelers very extensively, there being only one in the city who handles them. Bicycles are, however, being handled very largely by other houses. August Claus, one of the

principal jewelers of the city, is the only jeweler in the city who carries bicycles in stock. Mr. Claus says he is very well pleased with his trade so far on this article, having sold about 20 high grade wheels. He believes his business in this line will greatly increase. His sales have been checked considerable by the fact that the manufacturers of the wheels he represents are so far behind that they cannot get out the goods. He also has a repairing department and employs a man there. He sells the "Monarch," "Liberty" and the "Howard."

J. C. Pierik, of Sommers & Pierik, does not believe in jewelers handling bicycles and the firm will not add this line to their stock unless compelled to do so by circumstances. He is

**Buy  
"The Best"**

**THE  
"Dueber  
Special"  
BICYCLE.**

MAYSVILLE, KY., April 24, 1896.

Dueber Watch Case Mfg. Co., Canton, O.

Dear Sirs: The wheel came all right, and in fact exceeds my expectations. I have ridden the different high grade wheels for twenty years, and find this the easiest running wheel I have ever been on. Yours,

JOHN BALLENGER.

CHICAGO, ILL., April 23, 1896.

Dueber Watch Works, Canton, O.

Gentlemen: After a careful and critical examination of the "Dueber Special" Bicycle, I have no hesitancy in recommending it as a first-class wheel in every respect and I consider it the best wheel I have ever seen. The extreme care bestowed upon the fitting and finish of all parts, will alone recommend it to the watch making fraternity, who as a rule, are critical in these respects. The "Dueber Special" ranks with, if it does not surpass the highest grade wheels on the market. I see no reason why it should not have an enormous sale.

Very respectfully,

GEO. K. HAZLITT.

**IT STANDS AT THE HEAD.**  
THE LIGHT RUNNING  
**PEERLESS.**  
THE PERFECT WHEEL.



**LIVE JEWELERS**

can make money by  
handling our wheels.

Write for terms to Agents.

**BEAUTY — STRENGTH — SIMPLICITY.**

**THE PEERLESS MFG. CO.,**  
CLEVELAND, OHIO.

Send Two Cent Stamp for our new Booklet,  
"The Story of the Bicycle."

certain that the legitimate jewelry trade is being damaged by the bicycle business. Joseph Klaholt, another of the large jewelers here, does not believe in handling wheels and will never add them to his stock. George Chatterton, one of the oldest jewelers in the city, does not believe that bicycles should be handled by jewelers as he thinks this is an entirely independent business and should be run as such; and while he is aware that his trade is affected by bicycles he does not expect to ever put in a line of them.

#### PROVIDENCE, R. I.

PROVIDENCE, R. I., May 13.—Outside of J. A. Foster & Co., pawnbrokers and retailers, there is no jeweler who is handling bicycles in this city.

#### LYNCHBURG, VA.

LYNCHBURG, Va., May 13.—So far, no jewelers of this section handle bicycles; the trade is mostly with the hardware men. The fact

is, the topography of this city is not conducive to the use of the wheel to any great extent. There are only about 60 or 70 persons, adults and children, who enjoy the possession of a "bike." The only street that is really fit to ride a wheel on is Court St., which is paved in part with brick. The other streets are paved with Belgian block and cobble stone, and one rides over them at the risk of life and limb. Besides these obstacles, the hills are too steep for anything less than horse power to push a wheel up, and if a rider was foolhardy enough to start down one of our inclines, nothing short of a rock wall would stop him. The country contiguous to the city is also hilly, and as the country roads are not of the best, the people will naturally wait until the "bike" is more fully developed, easier to propel, or else is supplied with electric or steam power to carry it along. When wheels are made to scale declivities, stick to the side of a perpendicular wall, or fly, Lynchburg will take to the wheel, but not till then.

#### BURLINGTON, IA.

BURLINGTON, Ia., May 10.—There are no jewelers here making a specialty of bicycles; if they sell any it is only to a friend; they do not handle them.

#### BANGOR, ME.

BANGOR, Me., May 12.—Although the handling of bicycles has become one of the important side issues of Bangor trade, the jewelers of the city have not shown any appreciable amount of disposition to follow the procession by establishing themselves as agents; one reason for this is that the entire wheel trade of the city is controlled by a half-dozen large handlers, who absorb all the extensive profits, so that there is little inducement for others to enter the field with the intention of real competition. Of course, there are many dealers who have established agencies in order to secure an 1896 wheel at an agent's discount, but even this number is limited. Therefore the jewelers have wisely avoided the bicycle craze,

although most of them are riders. Only one leading jeweler, W. C. Bryant, successor to Chas. Hale & Co., is an agent of a bicycle; this gentleman, who is himself an enthusiastic wheelman, is agent for the "Transit" cycle, a South Boston article of 21 1-2 pounds listed weight, bright cherry-red finish, racing handle-bars, and the English price of \$110. Farther than this the jewelry trade of Bangor remains as yet unmarked by the entrance of the bicycle.

#### BIRMINGHAM, ALA.

BIRMINGHAM, Ala., May 13.—A canvas of the city develops the fact that local jewelers have not yet added cycles to their stocks and have not considered the matter seriously. Most of the wheels are in the hands of the hardware men, with a few agents who handle them in connection with typewriters.

#### NEW BEDFORD, MASS.

NEW BEDFORD, Mass., May 12.—New Bedford jewelers are not to any extent engaged in the bicycle business, nor are they likely to be. In fact, not a single dealer carries on the enterprise, though one or two clerks hold agencies. Louis E. Shurtleff, the Purchase St. jeweler, says that for a time he considered branching out in this direction and even got so far that he ordered a line of "Howard" samples. Before they arrived, however, he changed his mind and countermanded the order. He was led to take the first action because he had had much success in selling Howard watches and thought that their reputation would sell Howard bicycles. He gave up the idea because he found he really hadn't sufficient room to display a line of wheels and because he thought it best to stick to the legitimate jewelry business. Fred. W. Palmer, watchmaker with William L. Kelley, is engaged as a side issue in a bicycle agency, but the business is conducted entirely aside from Mr. Palmer's regular vocation.

Frank M. Jenkins, watchmaker and repairer



**ELGIN KING**  
\$100.00 BICYCLES  
ARE  
**SWIFT, STRONG,  
LIGHT AND HANDSOME.**

None better in any respect  
Write for Catalogue and Agents'  
Terms.  
Send 10 Cents for Elgin King  
Scarf Pin.

Address Department B,  
**ELGIN CYCLE CO.,**  
ELGIN, ILL.



**Puritan**  
CYCLES,  
\$100.

**The Puritan**  
...is a...  
**Boston**  
**Wheel.**

ALSO MAKERS OF  
**HECTOR**  
**BICYCLES,**  
**\$75.**

Factory Established in 1888.

It is High Grade  
Known as First Class.

WE GRANT AGENCIES ONLY TO JEWELERS.  
DISCOUNTS AND CATALOGUE ON  
APPLICATION.

**The F. Kroeber Clock Co., 360 Broadway, New York.**  
Sole Agents for the Jewelry Trade.



with George S. Kelley, holds the agency for "Puritan" and "Hector" wheels and has undertaken to carry on considerable business, even by the aid of advertising. Still, he says, he has yet to sell his first machine. This is not strange when it is considered that there are about 140 different wheels represented by agencies in New Bedford and Mr. Kelley's shop is not a good location for wheelmen. Mr. Jenkins says that he does not believe it at all wise for a jeweler to depart from his legitimate lines of trade. With a given capital, jewelry will yield as good returns to-day as a bicycle business and is far more dignified.

C. E. Woodworth held an agency a short time but did little more than to sell his samples; he then gave up the agency.

**WASHINGTON, D. C.**

WASHINGTON, D. C., May 19.—A ramble through the jewelry stores of the city reveals the fact that only two firms have introduced bicycles as a side line, although almost all the jewelry stores sell bicycle sundries, in dainty styles for ladies' use. Jacobs Bros. are agents for the "Stearns," "Dayton" and "Eagle" wheels, of all of which they keep a good line. They report business as fairly good.

The American Watch and Diamond Co., G. St., N. W., handle the "Monarch," "Horsman" and "Erie" bicycles, and the manager, R. M. Dobbins, reports business as very good. Both these firms express their intention to continue in the business while there is a demand for wheels.

**The Assignment of Wood, Bicknall & Potter.**

PROVIDENCE, R. I., May 22.—Wood, Bicknall & Potter, dealers in crockery, glassware, silverware, bric-à-brac, etc., 359 to 369 Westminster St., assigned to attorney James M. Scott last night, for the benefit of their creditors. The liabilities of the concern are placed somewhere between \$75,000 and \$100,000, a large proportion of which is held by out-of-town parties. The cause of the assignment is depression in business. The past three years have been bad for the concern, which coupled with the competition, has caused the firm heavy losses. The present firm succeeded Warren & Wood about eight years ago, Mr. Warren retiring at that time from active business on account of ill health. Mr. Wood has since continued in the business in connection with Frank Bicknall and J. W. Potter.

The creditors are widely scattered throughout the country, and, as the members of the firm were direct importers, there is said to be some indebtedness in Europe. The following is an approximate estimate of the assets and liabilities as submitted by the firm, Jan. 1st last, and shows the assets to be far in excess of the liabilities: Assets, stock in hand, \$101,000; credits, \$36,000; cash, \$1,000; fixtures, \$6,000; stock in steamer *Danielson*, \$300; life insurance, \$6,000; real estate, \$6,000; total, \$156,000—liabilities, bills payable, \$41,000; debts unsecured, \$35,000; total, \$76,000.

The assets are of course merely nominal; there will be a reduction in the actual assets, as the stock as it was then taken contained some old goods which will not bring the price of new stock, but even at this rate, it is now thought that the assets will exceed the liabilities.

**Auctioneers Complain that Jeweler Hamlin is Violating an Ordinance.**

ROCHESTER, N. Y., May 21.—A delegation of auctioneers waited upon Corporation Council Rodenbeck Tuesday for the purpose of impressing that official with the fact that the new ordinance relating to auctioneers was already being violated. It was alleged that Jeweler Hamlin is doing an auction business on State St. without a license and also that some person on Main St. was employing a "crier" in front of his place of business, contrary to the provisions of the ordinance.

Mr. Rodenbeck informed the delegation that the police department was on the watch for violations of this character and advised a conference with Chief Cleary.

**Jeweler Clegg's Store Destroyed in the Buffalo Building Collapse.**

BUFFALO, N. Y., May 21.—A section of the Seneca St. front of Brown's building collapsed at 9:25 o'clock this morning, burying a score of persons in the ruins. No. 14 Seneca St. was occupied by George Clegg as a jewelry store, which was destroyed in the collapse. Mr. Clegg was not injured.

**Straus American Cut Glass.**

We here illustrate one of our high grade cuttings, "The Constellation." This is an entirely new cutting, very rich and brilliant.

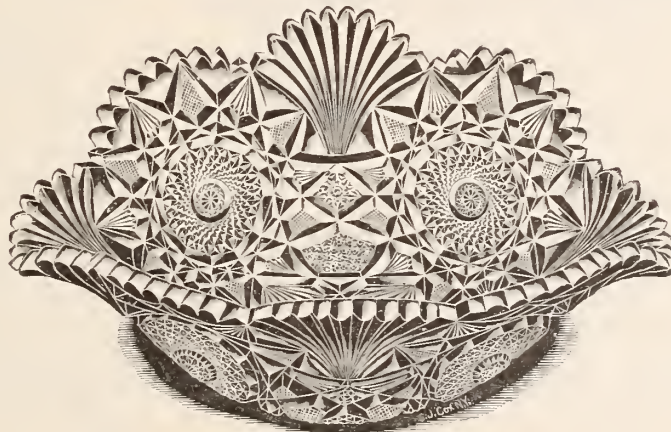

CONSTELLATION.

All of our Cut Glass is made in a large assortment of popular shapes and fancy patterns.

THE STRAUS CUT GLASS IS THE FIRST AND ONLY AMERICAN CUT GLASS USED BY H. I. M., THE CZAR OF RUSSIA, AND GREATLY ADMIRER BY HIS COURT.



**L. STRAUS & SONS,**

FACTORY,  
HOBOKEN, N. J.

42, 44, 46 and 48 Warren and 116 Chambers Sts., New York.

**Artistic Silver.**

Have you seen any more truly artistic or graceful spoon patterns than our "Apollo" and "Lexington," illustrated herewith? They are made in Sterling Silver only and in a full line of all sizes, including cutlery.



TRADE MARK.

**J. B. & S. M. KNOWLES CO.,**

PROVIDENCE, R. I.

Seen on Silver Shows Sterling.



THE APOLLO.



THE LEXINGTON.

**Early Summer Fashions in Jewelry and Silver.**

A LADY'S RAMBLES AMONG THE JEWELERS.

The gate purses are no longer a novelty, but continue to please, especially when made of silver gilt and attached to a long slender chain of gold.

Numbered with pretty trifles that please women are the silver embossed hair pin cases.

To wear on full dress occasions are long strings of pearls perfectly matched as to size.

Comport and berry dishes of cut glass and finely decorated china are now in order.

The variety in silver tea strainers is unlimited. A novelty in this direction is in shape of a salver that fits over the cup.

The so-called applied decorations are now, as always, much in use.

Seal chatelaine bags are very stylish and serviceable, and so are those made of lizard and water snake skin.

Garters designed as gifts to June brides are severely simple. The buckles are of plain gold, enriched with jewels, pearls being the favorite.

For smokers every luxury, down to cigar-cutters of hammered gold, are provided.

Lorgnette chains have taken on a new lease of life, and are now utilized for fancy purses.

In enameled goods, bonbon boxes, in shape of a book with clasps, attract deserved attention.

The city shops are full of beautiful belts. The array is a bewildering one.

Wreaths of tiny flowers, in silver, form the handles of embroidery scissors, designed especially for gifts.

The new combination belt and skirt-supporter is a convenience that bids fair to become popular with women patrons.

ELSIE BEE.

**A Settlement Likely in the Affairs of Nelson H. Davis.**

WORCESTER, Mass., May 22.—There promises to be an immediate settlement in the affairs of Nelson H. Davis, who failed several weeks ago. The failure was brought about by C. F. Stevens, who attached Mr. Davis' stock in favor of Simpson, Hall, Miller & Co., whom he represented. This was followed by other attachments, with the result that the affairs went into the insolvency court. At the first meeting of creditors before Judge William F.



**V**

Means everything that is first quality in Watch Glasses.

**T**

They are used by more Watch and case makers than all others.

**F**

Their success has induced others to copy the label but not the quality.

**PHILIP BISSINGER & CO.,**

IMPORTERS OF

PRECIOUS STONES, PEARLS, CORALS and GARNETS,

ANNOUNCE THEIR

**REMOVAL**

FROM 22 TO

20 JOHN ST., N. Y.

**AMERICAN WATCH CASE CO.,**

11 JOHN STREET, NEW YORK.

Manufacturers of **FINE SOLID GOLD CASES.**

Sold DIRECT to the RETAIL TRADE only.

**A.W.C.CO**

**PAILLARD = = WATCHES**  
**NON-MAGNETIC**

ARE AS GOOD AS THE **BEST.**

**R. A. LOVELAND, IMPORTER, 177 Broadway, New York.**

Forbes, Mr. Davis made an offer in composition of 20 cents on the dollar. The statement showed liabilities at \$16,000 and assets at only \$6,000 which, if sacrificed, in all probability would not reach two-thirds that amount. On April 15 it was announced that Mr. Davis had secured the assent of the creditors to accept the offer of 20 cents, and confirmation of Judge Forbes was expected. When the case was called the offer of 20 cents was abandoned, there being an objection by C. F. Stevens.

Before the examination proceeded, Mr. Davis filed an offer in the insolvency court of 25 cents on the dollar, an increase of five cents. An order of notice has been issued on this offer and is returnable for hearing May 29th. Lawyer Stevens, who objected to the previous offer, told a representative of THE CIRCULAR, Thursday, that he expected the creditors would assent to the new offer, and that it will go through without further trouble.

**Settlements in the Affairs of Lincoln, Bacon & Co. and Wade, Davis & Co.**

PLAINVILLE, Mass., May 23.—A settlement has been reached in the affairs of Lincoln, Bacon & Co. The difficulties of Wade, Davis & Co. have also been adjusted. In the case of Lincoln, Bacon & Co. all property of the late firm has been deeded personally to James D. Lincoln, as trustee for the benefit of the creditors whose interests are to be looked after by F. G. Pate, North Attleboro. The personal liabilities of Harland G. Bacon are assumed by the new management, thus leaving him free of all claims, personally. By this arrangement the creditors expect to net 80 per cent. of the total face value of their claims.

In the affairs of Wade, Davis & Co. a settlement has been reached on a basis that is more or less satisfactory to all concerned. A syndicate of the largest creditors has been formed, who have put \$8,000 into a pool. All the property of the late firm has been deeded in trust to a board of trustees who are yet to be chosen.

These trustees are to have the use of the \$8,000 and the immediate details of the business are to be managed by Whiting, Davis & Co., William H. Wade being out of the concern altogether.

When 50 per cent. of the indebtedness of Wade, Davis & Co. has been paid, together with the \$8,000 pooled by the syndicate with interest on the same, if there is a balance remaining, the trustees will transfer it to the new firm of Whiting, Davis & Co. By this arrangement William H. Wade is absolved from all liabilities of the late firm of Wade, Davis & Co.

**Manufacturing Jewelers' Board of Trade Matters.**

PROVIDENCE, R. I., May 23.—Secretary M. W. Morton, of the Manufacturing Jewelers' Board of Trade, this afternoon sent to every member of the Board a printed copy of the "Sterling Silver" bill recently passed by both branches of the General Assembly of this State, and called attention to the fact that it goes into immediate operation. At the last

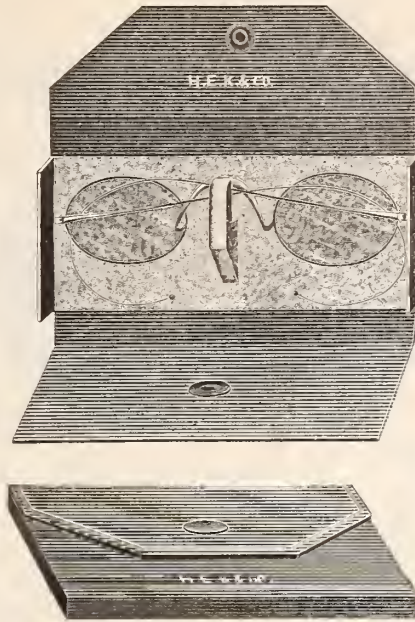

The Only Real  
**UNIVERSAL**  
Spectacle and  
Eye Glass Case.

ONE great advantage of this case is that one wearing a spectacle and eye glass (or two pairs of spectacles, or two pairs of eye glasses) can be perfectly accommodated with one case—the UNIVERSAL.

SEND \$1.50.

H. E. Kirstein & Co.,  
Rochester, N. Y.

**A** AMERICAN ESTABLISHED 1872.  
INCORPORATED 1894.  
**WATCH TOOL CO.**

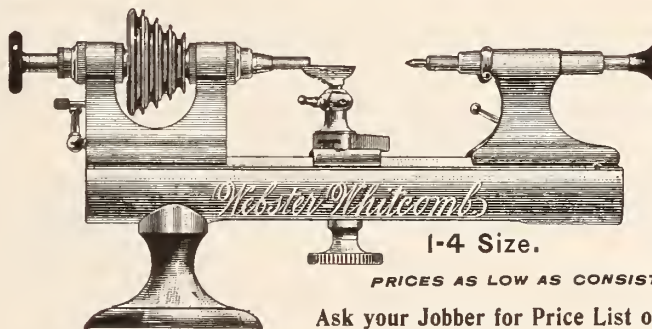

THE  
**Webster-Whitcomb**

GROWS IN POPULARITY

PRICES AS LOW AS CONSISTENT WITH QUALITY.

Ask your Jobber for Price List of 1895, or write to us at

**Stoney-Batter Works, Chymistry Dist., Waltham, Mass.**

**SLOAN & COMPANY,**

SUCCEEDING

JOHN A. RILEY & SLOAN CO.,

**MANUFACTURING JEWELERS,**

23 MAIDEN LANE, N. Y.

HAYS BUILDING.

AUGUSTUS K. SLOAN, Pres.

BENNET OSBORN, JR., Treas.

FRANK T. SLOAN, Vice-Pres.

ALLAN A. McDONALD, Sec'y.

**PATEK, PHILIPPE & CO.,** GENEVA, SWITZERLAND.

MAKERS IN THE HIGHEST QUALITY OF

**Fine, Plain, Complicated  
And Decorated Watches**

IN 15 DIFFERENT SIZES.

INTERCHANGEABLE PARTS.

NEW YORK OFFICE, 68 NASSAU ST.

ALFRED G. STEIN, Representative.

# NEW ORNAMENTS

... IN ...

## STERLING SILVER.



Many Designs in

Galleries, Belt Buckles,  
Belt Slides **AND** Belt Fastenings,

ALWAYS SOMETHING NEW.

### THOMAS W. LIND,

Manufacturer of

JEWELERS' FINDINGS.

67 Friendship Street,

PROVIDENCE, R. I.

## New Roy 12 Size Waltham Cases. Now on the Market.



**S**YMMETRY, STRENGTH, BEAUTY OF FINISH, SWISS  
HEAD SPRINGS, GOLD DUST BANDS, EXTRA THIN.

These are points of excellence which, as a result of years of experience, we have been able to make the most of, in constructing these splendid cases. They are made for the finer class of trade, only. Leading jobbers handle Roy Solid Gold Cases. Look for this Trade-Mark in every case.



ROY WATCH CASE CO., 21 Maiden Lane, N. Y.

## COMBINATION PURSE **AND** GLOVE HOOK.

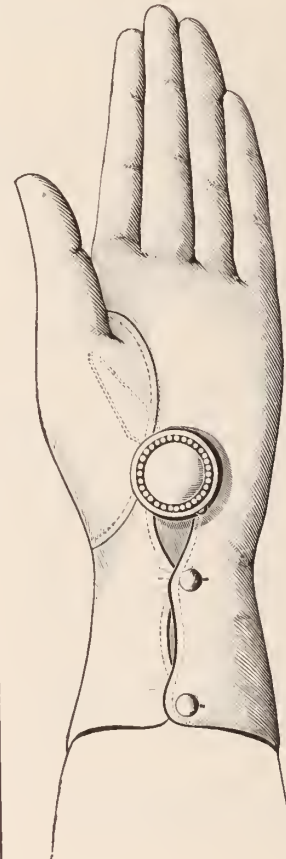
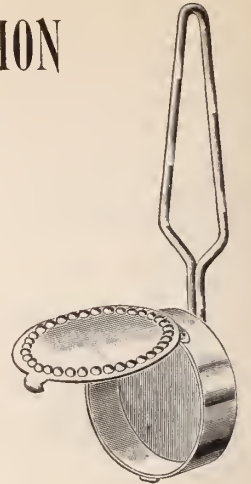

This absolutely new article is bound to have a large sale. It is extremely convenient, serves as an easily accessible carrier for small change such as is required for carfare—is securely held in the palm of the hand and saves its wearer from the insanitary practice of holding coin between the lips.

A SPLENDID NOVELTY  
MADE IN STERLING SILVER.



We are makers  
of Sterling  
Silverware  
Exclusively.  
All goods  
925-1000 fine.

F. M. WHITING CO.,  
North Attleboro,  
Mass.

hearing on the bill before the Judiciary Committee of the Senate, it was generally understood that the last clause regarding its immediate enforcement was to be amended so that the measure would not take effect until after July 1st. In the rush of business, however, the bill was passed without any such proviso, and persons now having goods in their possession marked "sterling" that are not up to the prescribed standard are liable to prosecution.

The rooms of the Board will be closed at 12 o'clock every Saturday during the months of June, July, August and September.

During the past week the Board has been disbursing to its members a settlement of 20 per cent cash on behalf of H. B. Barnes, of Chicago. The house has creditors in the east to the amount of about \$8,000.

**Sudden Death of Calvin Stone.**

PROVIDENCE, R. I., May 20.—Calvin Stone, one of the oldest manufacturing jewelers of this vicinity, met with a sudden death at his Summer residence at Shawomet Beach, Sunday night. In company with his family he went down to his cottage to spend the day. It was about 9 o'clock when the fatality occurred. No one seems to know just how, but Mr. Stone in some way missed his footing and fell to the foot of the stairs, and breathed his last before medical assistance could be summoned.

Mr. Stone was born in Warwick in 1829, and, after working upon a farm there until he was about 18 years of age, removed to this city. In 1847 he entered the employ of the old time manufacturing jeweler, C. C. Potter. With him Mr. Stone remained about five years, when he went with Briggs, Hough & Stone, with whom he remained until 1859, when he associated himself with his brother Isaac, in the firm of Isaac Stone & Co. For nearly a quarter of a century this concern were well-known throughout the trade. The firm went out of existence about 1891, although the deceased retired therefrom two years previously. Until about three months ago he did a small business, hiring rooms in various shops. At the time of his death he was a member of the recently organized concern of Wixon, Chase & Co., 363 Eddy St.

**O. W. Wallis & Co. Settling With their Creditors at 15 Per Cent.**

CHICAGO, ILL., May 24.—The American Trust and Savings Bank took possession of the entire stock and fixtures of O. W. Wallis & Co., by virtue of a chattel mortgage, Dec. 18, 1895, and after retaining possession three days, sold nearly everything in stock at public auction to satisfy its claims. Since that time the firm have devoted considerable time in assisting the assignee, Homer B. Galpin, to realize all that was possible out of the remaining assets, consisting of accounts and goods on memorandum. On May 18, the firm made an offer in

settlement of claims, viz.: 15 per cent. in cash on or before July 15th, 1896, or as soon as all creditors should have accepted the offer of settlement in writing, and state they can obtain the assistance of friends to carry out the settlement if it shall be consummated. In conclusion they say: "We regret that we cannot do more, and yet, being confident that no other course will produce as much, do not hesitate to ask you to sign and return the enclosed acceptance." The following is the form of acceptance:

We, the undersigned creditors of O. W. Wallis & Co., in consideration of one dollar to us in hand paid, do hereby agree to accept the sum of 15 per cent. in full satisfaction of our claim against O. W. Wallis & Co., provided such payment shall be made to us on or before the 15th day of July, 1896.

Each mail brings acceptances, and the signatures already secured include many of the best houses among the creditors. Mr. Wallis desires to again enter the business field. This is his sole purpose, and he takes the above method of securing to himself, if possible, the opportunity to again enter commercial circles. The offer is regarded here, as the best that can be made, and the signatures to the agreement so far are in evidence of the belief that the 15 per cent. is more than can be secured by creditors in any other way.

Era Rose, Joplin, Miss., has given a realty trust deed for \$7,850.

Mrs. Nan Little succeeds J. L. Miskimmin & Co., Belt, Mon.

**LORRAINE BELT RETAINER.**



FRONT VIEW.

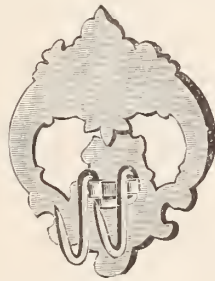

BACK VIEW.

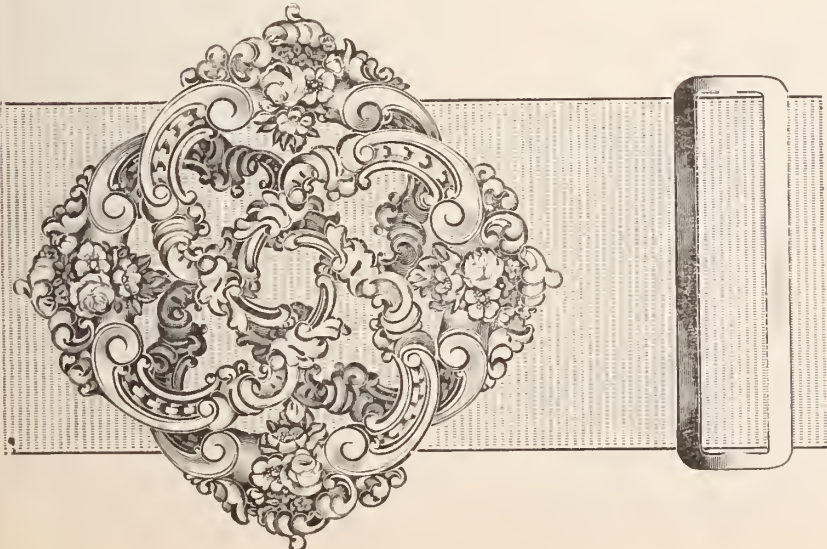

PATENT APPLIED FOR.

Made in great variety in 14k. Gold and Sterling Silver.

It is the simplest and most practical Belt Retainer in the market.

**BIPPART & CO.,**

Manufacturing Jewelers,

**NEWARK, N. J.**

- No. 8466 PLAIN SILVER.
- " 8467 OXIDIZED.
- " 8468 OLD GOLD FINISH.
- " 8469 SILVER GILT.
- " 8470 SILVER GILT ENAMEL.
- " 8471 SILVER ENAMEL.

**DIAMONDS.**  
**Wm. S. Hedges & Co.,**  
 IMPORTERS OF  
**Diamonds and Precious Stones.**  
**DIAMOND JEWELRY.**  
**170 Broadway, New York.**  
 22 Holborn Viaduct, London.

**Alfred H. Smith & Co.,**

IMPORTERS

DIAMONDS

AND

PRECIOUS STONES,

**182 BROADWAY, COR. JOHN STREET,**  
**NEW YORK.**

Venetian Building. **34 & 36 Washington St**  
**CHICAGO, ILL.**

**Purchasers**

.. OF ..

**RARE GEMS,**

PRECIOUS STONES  
 AND ALL GOODS FOR  
 JEWELRY,

ADDRESS

**R. A. KIPLING, Paris,**  
**19 Rue Drouot, France.**



**L. BONET,**  
 ESTABLISHED 1866.

**CAMEO  
 PORTRAITS**

Works of Art,  
 Precious Stones.

**927 BROADWAY  
 NEW YORK.**

**DON'T FORGET THE JEWELERS' CIRCULAR PUBLISHING CO.'S BOOK LIST when in want of any technical book in the Jewelry or Kindred Trades.**

**SCHULZ & RUDOLPH,**  
 IMPORTERS AND CUTTERS OF  
**DIAMONDS AND OTHER PRECIOUS STONES,**

(Successors to JOHN E. HYDE'S SONS.)

Sole Agents for **The Celebrated Jules Jurgensen Watches.**

**28 JOHN ST. and 65 NASSAU ST., NEW YORK.**

**The Bowden Rings**

ARE COMPLETE IN VARIETY, CORRECT  
 IN QUALITY AND PERFECT IN FINISH.  
 WE MAKE EVERY VARIETY OF FINGER  
 RINGS.

**J. B. BOWDEN & Co.,**  
**3 MAIDEN LANE,**

BRANCH OFFICE :

**206 KEARNY STREET  
 SAN FRANCISCO, CAL.**

**NEW YORK.**

**He Made the First Piece of German  
 Silverware in Providence.**

PROVIDENCE, R. I., May 20.—Ferdinand W. L. Knuschke, for 33 years a foreman in the works of the Gorham Mfg. Co., the first worker in the German silver business in this city, and an inventor of considerable ability, died at his residence, yesterday, in the 68th year of his age. For some years he has been in charge of the largest room of the factory, and his devotion to business undoubtedly hastened his death.

Mr. Knuschke was born at Offenbach-on-the-Main and was the son of a kid glove maker and cotton manufacturer. In his youth he learned the trade of a German-silver smith, and when 22 years of age he left home and came to America, going at once to Chicopee, Mass., where he started the tableware industry at the Ames Mfg. Co. After some years he left Chicopee and went to Hartford, Conn., and then to Taunton, Mass. From the latter place he entered the employ of the Gorham Mfg. Co., coming to the Steeple St. establishment to found the German silver business, Sept. 1, 1863. Mr. Knuschke made the first piece of German silverware ever turned out in this city.

During his connection with the company he made several inventions of value, including a water pitcher, with tilting cover. This he patented, presenting the patent to the Gorham Co., receiving a silver service in recognition. His most important invention he never patented, through conscientious scruples, and through a short-sighted policy on the part of the company it was placed on the market unprotected. The article is now in use in every civilized country on the globe. It is the common three-pronged soda water or ginger ale bottle holder, seen everywhere. Had he patented it, he would have been a rich man, and had the company secured a patent, the royalties would have been large. Mr. Knuschke saw that no practical holder existed for bottles with rounded bottoms, and invented this simple device, which, by prongs on three sides of a base, holds the bottle securely. Having made it with the material and in the time of the company, he felt that he had no right to patent it. He gave it to the company, but it was thought of no value, and was placed on the market without a patent, the result being that it was extensively copied everywhere.

**Matters Enacted at Albany.**

ALBANY, N. Y., May 24.—Among the bills signed by the Governor this week was the following: Assemblyman Kinne's, authorizing town and county co-operative corporations to insure against larceny of blankets, whips, clothing jewelry, grain, and any kind of farm produce, and all kinds of goods and property.

The Knickerbocker Silver Company, of Port Jervis, have been incorporated: Capital, \$55,000; directors, William N. Tuscano and Frank Nickerson, of New York, and Frank M. Linnell, of Boston.

Carl Entenmann, Los Angeles, Cal., has given a realty mortgage for \$1,500.

**News Items in Brief.**

E. L. Daron, Steelton, Pa., will retire from the jewelry business on June 1.

William Schmidt, of the jewelry firm of W. & E. Schmidt, Milwaukee, Wis., died May 20 in Denver, Col., aged 34 years. He leaves a wife and two children.

A couple of smooth burglars went through J. E. Gilleland's jewelry store, New Cambria, Mo., on the night of May 19, and took everything valuable that was not locked in the safe. Among the articles stolen were 17 gold rings, half a dozen gold pens, several pairs of bracelets, watch chains, etc.

George G. Wells, a pioneer settler in Minneapolis, Minn., died May 15, at Petoskey, Mich. He was formerly engaged in the jewelry business in Minneapolis and was at one time associated with W. H. Chamberlain in this business. In 1862 he enlisted at the opening of the Indian outbreak under Capt. Northrop, and marched to the defence of Fort Ridgley.

D. H. McNaughton, Lockhart, Tex., has assigned, and W. M. Steele was selected as trustee. The creditors are: First National Bank, \$450; John B. Holt, \$75; J. W. Sturges, \$20; Aurora Silver Plate Mfg. Co., \$88.32; Leonard Krower & Co., \$288; St. Louis Optical Co., \$58.96; C. Cederstrom & Co., \$20; M. Streicher & Co., \$180; Lapp & Flershem, \$141; total, \$1,313.26.

May 6, P. H. Lachicotte, Columbia, S. C., received a telegram from Georgetown announcing the death of his father, the Hon. P. R. Lachicotte, of that place. Mr. Lachicotte's jewelry store was closed during the day in consequence. The deceased gentleman was an extensive rice planter in the vicinity of Georgetown, where he spent most of his life. He was over 70 years of age. He was formerly member of the State Legislature.

**Cleveland, O.**

Grant Whittlesay, of the Julius King Optical Co., was in Detroit a few days last week, looking after the interests of his firm in that section.

Welb C. Ball visited Pittsburgh last week.

Walter G. King, who recently returned from an extended trip to the Pacific coast in the interests of the Julius King Optical Co., has again left, this time for a tour to Europe, where his company have a large business.

The bill which was passed by the Ohio Legislature recently requiring all persons who attach "M. D." to their names to appear before a State examining board at Columbus has gone into effect. This will include a number of the leading oculists in Cleveland, as they too must appear if they have "M. D." attached to their name. The bill is similar to one passed recently in New York State but not so sweeping, it being unnecessary for opticians to appear unless as above specified.

The Meriden Britannia Co., Meriden, Conn., have issued a new Chafing Dish Recipe Book, which they will be glad to send to any jeweler upon request. In view of the popularity of the chafing dish, this book should be in much demand.

ESTABLISHED 1840.

**RANDEL, BAREMORE & BILLINGS,**

IMPORTERS OF

**DIAMONDS,**

AND OTHER PRECIOUS STONES.

**FINE PEARLS A SPECIALTY.**

MANUFACTURERS OF

**DIAMOND JEWELRY**

A Large Stock of Fine Mounted Goods Constantly on Hand.  
Goods Sent on Approval and Insured in Transit.

Diamonds Cut, Recut and Repaired.

58 Nassau Street,  
29 Maiden Lane,  
NEW YORK.

1 Tulp Straat,  
AMSTERDAM.

1 St. Andrew's St.,  
Holborn Circus,  
LONDON E. C.

ESTABLISHED 1841.



**CARTER, HASTINGS & HOWE,**

MANUFACTURERS OF

**GOLD JEWELRY,**

**15 MAIDEN LANE, NEW YORK.**

A CARTER,

C. E. HASTINGS,  
W. T. CARTER

C. R. HOWE  
W. T. COUCH

FACTORY, NEWARK, N. J.

**JOHN P. CAMPBELL,**  
MANUFACTURER OF  
**WATCH CASES.**

ALL KINDS OF SPECIAL CASE WORK.  
REPAIRING A SPECIALTY.

59 Nassau St., Cor. Maiden Lane, New York.

Royal Arcanum and Maltique Ladies' Enamel Cases.

**HERMAN KOHLBUSCH, SR.**

Established 1859  
Manufacturer of  
FINE BALANCES  
AND WEIGHTS for  
every purpose  
where accuracy is  
required. 59 Nas-  
sau Street, cor.  
Malden La. N. Y.

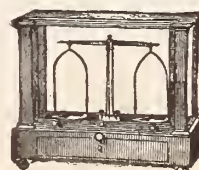

Repairs (any make)  
promptly made.

# OPPENHEIMER BROS. & VEITH,

CUTTERS OF DIAMONDS,

DEALERS IN WATCHES,

65 NASSAU STREET (PRESCOTT BUILDING), NEW YORK.



### IN EVERY HOME

There is a possibility of placing at least one of these beautiful groups.

Price of this one, \$10.00

A writer in the "New England Magazine" says, "There are few men in this country, among the artists, who know the horse as well as Rogers."

Send for Handsome Catalogue and Trade Prices.

Rogers Statuette Co.,  
441 Pearl St., N. Y.

A. WALLACH & CO.,

Manufacturers of

## Gold Chains,

11 Maiden Lane,

Adolph Wallach, &  
Antony Wallach.

NEW YORK.

L. ROSENBERGER,  
M. ROSENBERGER.

## A. WALLACH & CO.

### This card

appeared in the "Jewelers' Circular" of April 15, 1870.

### For 50 years

Wallach Fine Gold Chains have been recognized as the standard.

### We have

recently removed to new quarters at

37 and 39 Maiden Lane,

Lorsch Building,

Room 8.

### The Charles Jacques Clock Co. in the Hands of a Receiver.

The Chas. Jacques Clock Co., importers of clocks and bronzes, 22 Cortlandt St., New York, went into the hands of a receiver last week. The appointment was made in suits brought by Montague F. Harris, president of the company, and A. Wardner Harrington, secretary, who together hold 569 of the 960 shares of stock.

The Chancery Court, of New Jersey, in which State the company were incorporated, Thursday named Albert C. Wall receiver of the company, and Judge Truax, in the New York Supreme Court, Friday appointed Mr. Wall receiver of all the company's assets and property in New York. The order gives the usual powers and enjoins severally the directors and others from selling the property or interfering with the receiver.

The complaint of Messrs. Harris and Harrington states that the company are unable to meet their obligations and that the assets if sold under forced sale would not realize sufficient funds to discharge the indebtedness. They believe that if the property be preserved, the debts can be liquidated under the protection of the court, and if properly managed the property will realize sufficient to pay all creditors in full. The obligations consist to a large extent of notes due or soon to become due. The company's principal stockholders are: A. W. Harrington, 412 shares; Montague F. Harris, 157 shares; Charles A. Jacques, 146 shares; Ida H. Jacques, 136 shares, and Wm. C. Orr, 104 shares.

The schedule given in the complaint shows the assets to be \$30,967.17 and the liabilities \$21,730.34; \$14,366 of the assets consists of merchandise in the store with \$2,000 worth of materials. The merchandise in warehouse amounts to \$5,158.72. The remaining assets consist of about \$4,500 in accounts due, \$325 in the bank, fixtures, tools and machinery valued at \$2,500, and good-will estimated at \$2,000. Of the liabilities, \$18,631.80 is the amount of bills payable; \$1,381.23 is due to M. F. Harris; \$908.85 to J. A. Lundy, and \$625 is owing for rent.

President Harris stated Saturday that he did not then know whether the company would resume or have their affairs wound up. The merchandise indebtedness, he said, was all in Europe and in the hands of one firm. He was awaiting a cable from Europe before determining what should be done. He said the application for a receiver was due to lack of capital and to poor collections.

### The Designs of these Spoons Are too Close.

Boston, Mass., May 21.—Judge Colt, in the United States Circuit Court, to-day handed down a decision in the case of the Gorham Mfg. Co. vs. Clarence L. Watson, Frederick A. Newell, Joseph L. Ripley, E. A. Gowan and Watson, Newell Co., Attleboro. The decision grants a preliminary injunction against the individuals restraining them from using a design on the handle of spoons and forks similar to one patented by the Gorham Mfg. Co.

We carry the largest, finest and most complete line of Mounted Diamond Jewelry of any house in America.



16 JOHN S. NEW YORK



The case is dismissed as to the Watson, Newell Co., on the grounds of no jurisdiction, Judge Colt holding that as the two corporations are inhabitants of Rhode Island that the Massachusetts court has no jurisdiction. The individual defendants are inhabitants of Massachusetts, and alleged to be members of the Watson, Newell Co.

The Judge states that he is of the opinion that the complainants have made out a case which makes the defendants personally liable to an injunction, and upon the question of infringement of the patent on the design used on forks and spoons by the Gorham Mfg. Co., the court says there can be no doubt. A comparison of the defendants' design with the patent shows a close imitation. In the complaint the Gorham Co. allege that dry goods and department houses display their goods, but that when purchasing a person is given the goods made by the defendants, and which they allege are inferior.

**Proposed Legislation in Ohio Affecting the Opticians' Business.**

CINCINNATI, O., May 23.—The optical dealers met this week again and discussed many important questions pertaining to their trade. L. M. Prince, the president, says that he was summoned to Columbus to attend a meeting of the medical fraternity in relation to the bill passed in February regulating the practice of medicine. He could see nothing in this bill of interest to the opticians, except in one word, "infirmities," which might include di-

seases of the eye. The eye specialists are interested in the passage of a bill to prohibit any other than specialists fitting glasses. This would interest a large class of opticians who make this a business.

There are a number of oculists who are using their influence in the passage of such a bill. These men sell glasses and hope to increase their trade by cutting off the opticians' line. Mr. Prince will attend the proposed meeting to learn what interest they have in the bill. Another meeting of the opticians will be called as soon as these matters assume shape for report.

**Annual Meeting of the Nebraska Retail Jewelers' Association.**

ST. LOUIS, Mo., May 23.—The Retail Jewelers' Association of Nebraska met Wednesday afternoon, May 20, in the rooms of the Commercial Club, Omaha. While the attendance was not as large as in former years, it was as large as was expected. There were about 30 jewelers from outside points in attendance.

President Richard O'Neill, of Lincoln, was in the chair, and after calling the meeting to order, introduced Mayor Broatch, of Omaha, who made a felicitous address of welcome, which was well received. Mr. O'Neill responded in behalf of the Association, and then made his annual address. He stated that the jewelers, in common with the balance of the business community, could not congratulate themselves on the results achieved during the

past 12 months, but he was certain that brighter days were dawning.

The secretary's report showed that, in spite of the hard times, the Association had maintained its membership. The annual election of officers was then held, with the following results: President, Fritz Hoefer, Aurora, Neb.; vice-president, Walter C. Kerns, Pawnee City, Neb.; secretary, F. A. Hannis, York, Neb.; treasurer, John Baumer, Omaha, Neb.; board of directors, J. A. Ruling, Wymore, O. Z. Zinn, Hastings, Wm. Conrad, Tecumseh; delegates to the National Association Convention, Geo. Arkwright Beatrice, F. A. Hannis, York; alternates, John Baumer, Omaha, Francis Lemon, Ashland.

In the evening a banquet was tendered the Association by the wholesale jewelers of the city. After the good things had been discussed, H. E. Duncan gave a lecture on the "Escapement of the Waltham watch," which was very favorably received.

The business of Merrill Bros. & Co., silver-smiths, 31 E. 17th St., New York, has increased to such an extent that the firm have been obliged to remove their factory, formerly at 4th and Dickerson Sts., Newark, N. J. In their new location, at Oliver and McWhorter Sts., Newark, they have much more room than heretofore, and are located on the ground floor with good light from four sides. Much new machinery has been added to the firm's plant.

**THE MOST POPULAR BUCKLE**

—• IN THE MARKET. •—

All Belts  
Interchangeable.

Our Belt Hook

is the only perfect arrangement for holding the skirt under Leather Belts.

PLAIN OR FANCY.

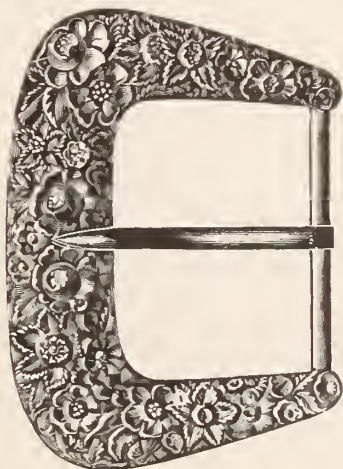

NO. 3911/1.

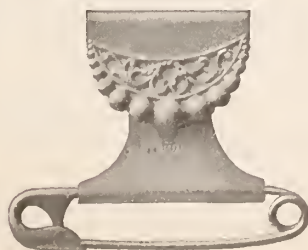

NO. 3840.

MOUNTED ON FINEST LEATHER BELTS, ALL COLORS.

BAGS TO MATCH.

**SIMONS, BRO. & CO.,**

SILVERSMITHS  
AND MANUFACTURING  
JEWELERS,

PHILADELPHIA,  
NEW YORK,  
CHICAGO.

**BATES & BACON**  
"FAVORITE"  
14K

**ALWAYS**

Ask to see  
our

**BATES & BACON**  
"ROYAL"  
14K

**GOLD FILLED**  
WATCH CASES.

**None Better**  
and  
**Few Equal.**

**BATES & BACON**  
"PURITAN"  
14K

**FISHING**

**To Dealers Only.**

**SPLIT BAMBOO RODS,**  
From \$10.80 per doz.,  
to \$76.50 each.

**ALL LANCEWOOD RODS,**  
From \$9.90 per doz.,  
to \$3.00 each.

136 page Catalogue Free.  
Send for it.

**ABBEY & IMBRIE,**  
21 VESEY ST.,  
New York.

**TACKLE.**



A Large Number of Small

## Advertising Cuts

Specially Designed for JEWELERS'

ADVERTISING, such as above, at

75 Cents per Electrotype.



SEND FOR PROOF SHEET.



**THE JEWELERS' CIRCULAR PUB. CO.,**

189 Broadway, New York.

### Boston.

Peter Closs, spectacle case manufacturer, is on a business trip to Geneva, N. Y.

Samuel Friebe, trade watchmaker, has removed from 403 to 383 Washington St., taking a corner in the store of Howard & Whelan.

George E. Morrill, manager of the Canadian branch of the Climax Bell Co., Montreal, has been visiting his friends in the Boston trade this week.

O. A. Drinkwater, of the Morrill Bros. Co., who has been seriously ill for a number of months, was able to be in town and visit the store of the concern last week.

The [American Waltham Watch Co. will have their usual Summer vacation in July, closing the factory on the 18th of the month, and remaining shut-down five weeks.

John Bonney, who has been with Geo. H. Richards, Jr. & Co., upward of four years, went to Denver, Col., last week, with the intention of locating permanently in that city.

Buyers in town the past week included: E. A. Chandler, West Gardner; E. S. Clark, Sandwich; F. L. Pond, Keene, N. H.; E. E. Shedd, Eastport, Me.; A. B. Skinner, Keene, N. H.

President Samuel Little, of the E. Howard Watch and Clock Co., has removed to his Summer residence at Marblehead. D. C. Percival has also opened his Marblehead residence for the Summer.

James F. Hartshorn, engraver for the jewelry and watch trade, heretofore in Geo. E. Homer's Washington St. store, has removed to the corner of Tremont St. and Hamilton Place, taking quarters in the store of Chas. Foss.

Charles A. French, optician, against whom an injunction was issued, restraining him from using prescriptions for glasses copied from the files of John W. Sanborn, his former employer, has been fined \$100 for contempt of court, having violated the Judge's order to desist.

The following changes are reported in the optical line: William R. Donovan, formerly with Millar & Welch, is now in the employ of C. E. Davis; R. R. Doescher goes with Millar & Welch; Levi Lovelly, recently with the Richmond Optical Co., has taken a position with A. G. McKenzie.

George H. Richards, Sr., Keene, N. H., was in Boston the past week on a sad errand, having accompanied the remains of his deceased brother, which were brought to this city for burial. Mr. Richards is one of the old-time jewelers of New Hampshire, and the grandfather of Herbert W. Richards, of George H. Richards, Jr. & Co.

Benjamin Ellis, whose place of business for 30 years has been a stand in the doorway at 352 Washington St., and one of the landmarks of the city's busiest thoroughfare, will have to move therefrom shortly, being denied a renewal of the privilege by the present lessees. Mr. Ellis is reputed to have made more money in the optical business than any other optician in Boston.

### Annual Meeting and Banquet of the New England Association of Opticians.

BOSTON, Mass., May 20—The New England Association of Opticians held their annual meeting and banquet last night, the former in the usual meeting room of the organization at Young's Hotel and the latter at the Quincy House. At the business session the following officers were elected: President, F. E. Welch; vice-presidents, Benjamin V. Howe, A. G. McKenzie, Sylvester Eastman; secretary and auditor, William R. Donovan; treasurer, Edwin P. Wells; executive committee, A. J. Landry, George H. Lloyd, E. M. Parks, John W. Sanborn, F. H. Blackinton, E. G. Worthley, Ebenezer Hardy; investigating committee, Albert G. Barber, John W. Sanborn, E. Hardy.

President-elect Welch presided at the banquet and the guests of the occasion were Dr. Ephraim Cutter, New York, James P. Prince and A. H. Avery. Around the table were the following members: Frank E. Welch, George H. Lloyd, Albert G. Barber, John W. Sanborn, Alexander G. McKenzie, F. H. Blackinton, William R. Donovan, Benjamin V. Howe, A. H. Martin, Edwin P. Wells, Briggs S. Palmer, R. R. Doescher, C. P. Van Alstine, G. H. Shepard, H. A. Bigelow, Gilbert H. Aymar, Herbert McNamara, E. G. Worthley, Everett W. Flint, C. W. Hurl, Jr.

Dr. Ephraim Cutter gave interesting facts regarding "Wonders Revealed by the Microscope" in an after-dinner talk which was much appreciated; James P. Prince, who is a member of the bar, spoke on the advisability of "State Registration of Opticians," and Mr. Avery and several of the other participants made entertaining remarks. The exercises were enlivened with music by an orchestra.

The organization is in a prosperous condition and starts the current year with every promise of success numerically and financially, as well as in the furtherance of plans for mutual help and friendly intercourse which have given character thus far to the association.

John Johnson, Baton Rouge, La., died recently.

Morris Lewis, New Orleans, La., has been sued for \$2,761.

The effects of J. W. A. Redhouse, St. Mary's, Kan., have been attached.

Jacob F. and M. J. Shambough, Chicago, Ill., have confessed judgment for \$480.

ESTABLISHED 1849.

INCORPORATED 1890.

**J. BRIGGS & SONS CO.,**

MANUFACTURERS OF

**Gold and Silver Plate and Seamless Wire,**

65 CLIFFORD STREET, PROVIDENCE, R. I.

WE MAKE



STOCK FOR

CANE HEADS,  
UMBRELLA MOUNTINGS  
PENCIL-CASES,  
WATCH-CASES,  
WATCH-CROWNS,  
THIMBLES,  
SPECTACLE AND  
EYE-GLASS BOWS,  
DIAMOND MOUNTINGS,  
&c., &c., &c.

# Our Traveling Representatives



Traveling representatives may consider these columns open for the publication of any news or items of interest regarding themselves or their conferees.

**T**RAVELING men in Indianapolis, Ind., last week included: C. O. E. Hartung, Sussfeld, Lorsch & Co.; B. Brady, B. B. Brady & Co.; S. Levy, S. Levy & Co.; Mr. Guyer, Waterbury Clock Co.; Mr. Tibbets, Wilcox Silver Plate Co.; Fred Foster, Unger Bros.; J. F. Townley, Ripley-Howland Mfg. Co.; John A. Davis, Wm. Rogers Mfg. Co.; Mr. Barry, Larter, Elcox & Co.; and representatives of Sloan & Co., and H. H. Smith & Co.

George H. Tarlton has resigned his position as road salesman for the silverware department of J. W. Tufts, Boston, Mass.

Travelers in Pittsburg, Pa., last week were: Charles A. Moore, Moore & Co.; Albert L. Stearns, Roy Watch Case Co.; Mr. Brooks, Brooks & Pike; J. D. Barber, Landers, Frary & Clark; Frank L. Wood, Carter, Hastings & Howe; L. Hirsh, for Manasseh Levy; E. H. Phillips, H. L. Judd & Co.; Mr. Gregory, Strobell & Crane; S. Sickles, M. Sickles & Sons; Robert Welch, Welch & Miller.

Traveling salesmen calling on Davenport, Ia., jewelers the past week were: Arthur T. Peck, C. B. Barker Mfg. Co.; L. E. Smith, M. B. Bryant & Co.; B. F. Williams, Landers, Frary & Clark; Frederick Purdy, J. H. Purdy & Co.; Steve H. Fridges, H. F. Hahn & Co.; H. G. Scramm, Theo. Schrader & Co.; A. E. Charlesworth, Johnston Optical Co.; S. R. Jonas, Levy, Dreyfus & Co.; M. W. Smith, Kent & Stanley Co., Ltd.

Among the traveling men in Philadelphia, Pa., the past few days were: John D. Battin, Battin & Co.; Frank L. Wood, Carter, Hastings & Howe; E. H. Eckfeldt, Eckfeldt & Ackley; Archibald Rutherford, Kirby, Mowry & Co.; Charles Duffy, Enos Richardson & Co.; Frank I. Locklin, Unger Bros.; Benjamin Griscom, Bippart & Co.; Harry B. Beach, Wilcox Silver Plate Co.; Mr. Pierce, Harrison Bros. & Howson; Mr. Beiderhase, Alvin Mfg. Co.

The following traveling salesmen passed through Detroit, Mich., last week: H. H. Bradley, the E. A. Bliss Co.; John W. Case, H. F. Carpenter & Son; Harry Osborne, the Howard Sterling Co.; C. W. Cary, the J. B. & S. M. Knowles Co., W. C. Barry, Larter, Elcox & Co.; J. R. Goodwin, Carter, Hastings & Howe; Fred M. Wheeler, Dominick & Huff; A. J. Sherrard, Enos Richardson & Co.; M. H. Harrison, Harrison & Groeschel; Mr. Butler, George Borgfeldt & Co.; Alfred Varian, the Dennison Mfg. Co.; F. Meyer, Goldberg & Meyer, and Mr. Foster, Unger Brothers.

Traveling men in Louisville, Ky., last week were: W. A. Morse, for F. W. Gesswein, Est.;

Mr. Somborn, Albert Berger & Co.; Henry Cowan; C. B. Burgesses, F. M. Whiting Co.; L. E. Smith, M. B. Bryant & Co.; W. S. Strauss, Jacob Strauss & Sons; Stephen B. Kent, William H. Ball & Co.; Mr. Tinker, for W. B. Durgin; Robert Welch, Welch & Miller; Mr. Herman, D. Schroder & Co.; Earnest A. Rose, Jos. H. Fink & Co.; I. B. Ettinger, Keller, Ettinger & Fink; F. C. Allen, for A. Wittnauer; Charles S. Williams, Landers, Frary & Clark.

Among the knights of the grip who have called on Cleveland, O., firms lately are: Cy Pickering, Shoemaker, Pickering & Co.; A. J. Simonson, A. J. Hedges & Co.; J. R. Goodwin, Carter, Hastings & Howe; Mr. Lawton, Dennison Mfg. Co.; Mr. Wheeler, Dominick & Huff; Harry Osborne, Howard Sterling Co.; C. W. Cary, J. B. & S. M. Knowles Co.; Mr. Davis, Middletown Plate Co.; Mr. Carter, Sloan & Co.; T. H. Brooks, Brooks & Pike; Mr. Sowade, A. J. Grinberg & Co.; Mr. Foster, Unger Bros.; Mr. Downing, Downing, Keller & Co.; Chas. B. Bartlett, Whiting Mfg. Co.; the representatives of Manasseh Levy, Deutsch Bros., John W. Reddall & Co., and others.

Traveling men in the Hub the past week included: Samuel Levy, L. & M. Kahn & Co.; John A. Abel, Lewis, Kaiser & Luthy; T. B. Wilcox, Jr., Pairpoint Mfg. Co.; S. E. Fisher; Eugene H. Cox, Sussfeld, Lorsch & Co.; William H. Jones, Jones & Woodland; G. B. Osborn, William Smith & Co.; H. D. Sherrill, Sinnock & Sherrill; C. H. Barney, Middletown Plate Co.; A. A. Wood, Howard Sterling Co.; Frank Wood, Carter, Hastings & Howe; J. D. Pettengill, Derby Silver Co.; J. L. Sweet and Louis Jones, R. F. Simmons & Co.; L. Kurtz, G. W. Cheever & Co.; E. W. Martin, Martin, Copeland & Co.; Louis Fay, Kirby, Mowry & Co.

## Canada and the Provinces.

W. E. Blakeley, Brighton, Ont., is in Toronto taking a course in optics.

B. Didisheim, of H. Didisheim & Bro., of New York, was in Toronto Monday last.

R. H. Thompson, representing Sinnock & Sherrill, New York, was in Toronto last week.

F. C. Davey, Deseronto, Ont., is to be united in marriage this week to a lady of that locality.

M. G. Howe, formerly of Arnprior, has started in the jewelry business in Carlton Place, Ont.

E. A. Skinner, representing E. G. Webster & Son, Brooklyn, N. Y., was in Montreal recently.

Among the provincial buyers in Toronto last week were: H. Ross, Mount Albert; John T. Barnard, Whitby.

J. A. Pitts, Montreal, who recently returned from a trip to New York, has started out on a trip through the lower provinces.

Among the visitors to Montreal, recently, were Jacob Levy, Levy Bros. Co., Hamilton; J. Saunders, Toronto; Cyr Ducette, Quebec, and G. F. Goodwin, Arnprior.

Geo. Chillas, Montreal, has spent the last four weeks in the towns of Ontario and is expected to return home in a few days. He has done a good business in his special lines of cut glass and silver goods.

E. C. Fitch, president of the American Waltham Watch Co., was registered at the Windsor, Montreal, a few days ago, having arrived from Quebec, where he has been having his yacht fitted out for the annual trip to his fishing reserve on the River Romaine.

## The "Never Sag" Belt Attachment . . . .

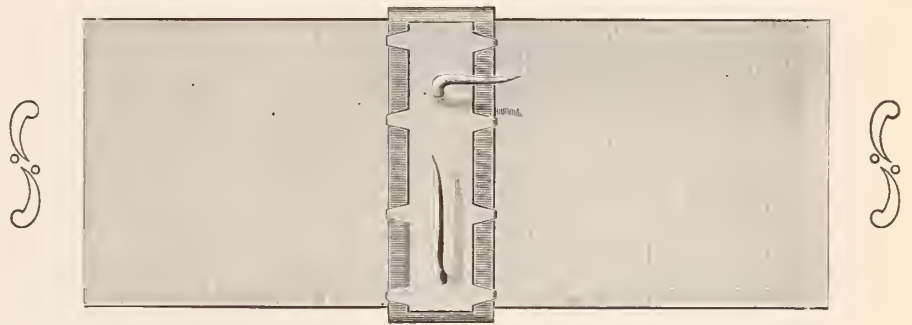

PATENTED.

With our "Never Sag" Belt Attachment, you can wear the popular narrow belts and feel content in the knowledge that your skirt cannot sag, even the fraction of an inch. Your shirt waist too, will always be in its proper position.

**NO BUTTONS TO SEW ON. WILL NOT TEAR THE FABRIC.**

Applied to any width of belt from one inch to two and a half inches. Apply our "Never Sag" attachment to your leather slides, it will more than double your sales.

Send for Samples and Prices.

**E. L. LOGEE & CO.,** Patentees,

183 Eddy Street,

Providence, R. I.

Made in Sterling Silver and Silver Plate.

### Providence.

All communications for this column addressed to P. O. Box 1093, Providence, R. I., will receive immediate attention

S. C. Shurtleff has removed from 107 Friendship St. to 59 Page St.

H. Arabian has started in the enameling business at 25 Calender St.

The Providence Optical Co. have removed from 129 Eddy St. to 7 Beverly St., in the shop partially occupied by J. G. Fuller & Co.

Fred S. Reynolds is fitting up his new shop in an excellent manner and getting out tools and putting in new machinery for the production of a high grade of metal designs.

Among the buyers in town the past few days were: Geo. Greenzweig, San Francisco; Herman Cerf, Pittsburg; Henry Pfaltz, J. Levy, J. Rosenteil and C. Brandenstein, New York.

Local manufacturers have received intelligence of the assignment of J. Warren Davis, Portsmouth, N. H., with liabilities estimated at \$6,000 and assets at \$2,000. The loss here is small.

Ulysses Racine has recently purchased the business of tool making, hub cutting and designing from Frank Salisbury, and in connection with his own business will continue at 85 Page St.

J. O. Simmons and Charles T. Paye, formerly with the Shepard Mfg. Co., Melrose, Mass., have started in the designing and engraving business at 209 Pine St., under the style of Simmons & Paye.

### The Attleboros.

Frank S. Sargeant has recently commenced the manufacture of novelties.

Charles H. Wetherell, who has been ill for

some time, has started on a tour to Maine.

M. E. Bliss has resigned his position with the Mossberg Mfg. Co., and been succeeded by John Tregoin.

A portion of the machinery of the Watson & Newell Co. was removed the past week into their new factory building.

The matter concerning the removal of the Mossberg Mfg. Co.'s factory seems to be at a standstill and nothing definite can be learned in regard to it.

Frank Fonteneau, having purchased a controlling interest in the W. F. Briggs Co., of Attleboro Falls, the firm name has been changed to Frank Fonteneau & Co.

Walter Allen and Frank Smith, formerly with the late firm of Blake & Clafin, and Henry Thurston, for several years tool-maker for Daggett & Clap, and recently with the Bay State Optical Co., have formed a copartnership and will manufacture jewelry novelties under the style of Allen, Smith & Thurston. They occupy a portion of the shop at present occupied by James McNerney & Co.

### Philadelphia.

John F. Simons has been elected a director of the Manufacturers' Club.

Samuel S. Maker, a well known engraver, died a few days ago at his home, 308 Marriott St.

H. C. Rowbotham, representing J. Muhr & Bro., started, May 23, for a six weeks' business trip through the west.

Contracts for the furnishing of valuable prizes for the Schuylkill Navy regatta in June have been awarded to Sackett & Co.

Rules have been prepared under which the Simon Muhr free scholarships in law, medi-

cine, dentistry, pharmacy, engineering, music, architecture and fine arts will soon be awarded.

Friends of George W. Scherr, of Louis A. Scherr & Co., are concerned over his physical condition. Mr. Scherr has been ill for a month and lately had an operation for appendicitis performed. He is now in a serious condition.

Some of the most beautiful and appropriate prizes ever offered for bicycle competitions have been manufactured by Simons, Bro. & Co., for the Warwick Bicycle Meet, May 30 in Tioga. The prizes and two bicycles of splendid quality in a large glass case, are exhibited in the firm's Chestnut St. window.

S. Kind & Co. have leased the Chestnut St., premises adjoining the store of George Eakins & Co. on the east, and in connection with their jobbing business will open a retail jewelry store at an early date. S. Kind & Co. will vacate the store at 5th and Market Sts., after extensive alterations have been made to their new establishment.

It is probable that the Herman Keck case will soon be pressed to a trial in the United States District Court. Judge Butler has overruled a demurrer and a motion to quash the indictment against Keck. A question of the court's jurisdiction was raised by counsel for the defendant, it being argued that if an offense was committed by Keck it was in Belgium and that he was not in the jurisdiction of Judge Butler's court until Keck was brought here in custody. The attorney for defense also asked that a commission be named to hear testimony in Belgium but this request was likewise refused. Keck was indicted May 18th with Captain Franz Loesewitz, of the steamer *Rhyland*, and one Von Hemelrick, in connection with the alleged smuggling of 563 diamonds valued at \$10,000 into this country from Antwerp, without entry and without payment of duty.

### Pittsburgh.

In a disastrous fire on May 23d., Sewell's jewelry store, Sistersville, W. Va., was completely burned out.

Visiting jewelers in the city last week included: Jacob Wolf, Suterville, Pa.; R. H. Wolf, Smithton, Pa.; H. S. Johnston, Apollo, Pa.; H. C. Morrison, Mt. Pleasant, Pa.

S. Loudon, employed in Teplitz's jewelry store, McKeesport, took \$114 from the money drawer and deposited it in the bank in his own name, claiming Teplitz owed him. He refused to refund and was committed to jail.

THE CIRCULAR correspondent has been informed that A. C. Ray, Mercer, Pa., has succeeded W. B. Bard, same town; that Mather Bros., formerly located at Bellevernon, Pa., have removed to Newcastle, Pa.

Edward Purkey, one of the clerks employed by B. E. Arons, was committed to jail in default of \$1,000 bail on a charge of larceny preferred by Mr. Arons. Purkey for the past nine months has been disposing of watches, diamonds and jewelry of all kinds that did not belong to him. Mr. Arons places his loss at \$2,000. Detective Demmel has charge of the case, and has recovered about \$300 worth of jewelry.

### A. WITTAUER,

SUCCESSOR TO  
J. EUGENE ROBERT & CO.,  
IMPORTER AND MANUFACTURER OF  
PLAIN AND COMPLICATED

WATCHES AND  
WATCH MOVEMENTS,  
19 Maiden Lane, New York.

WE CATER TO THE JEWELRY AND STATIONERY TRADES ONLY.

### ALFORD & EAKINS,

Successors to Henry G. Alford 73 Nassau Street, New York.  
ENGRAVERS, PRINTERS and EMBOSSERS,

Manufacturers of fine Wedding Invitations,  
Reception and Calling Cards, etc., etc.

We guarantee our workmanship equal to  
our samples, and superior by comparison to  
any now on the market. TRY THEM.



# The Jewelers' Circular AND HOROLOGICAL REVIEW.

PUBLISHED EVERY WEDNESDAY BY

THE JEWELERS' CIRCULAR PUB'G CO.,

189 BROADWAY, NEW YORK CITY.

A JOURNAL DEVOTED TO THE INTERESTS OF JEWELERS, WATCHMAKERS, SILVERSMITHS, ELECTRO-PLATE MANUFACTURERS, AND ALL ENGAGED IN KINDRED BRANCHES OF INDUSTRY.

Member of the American Trade Press Association.

Our Editorial columns will contain our own opinions only, and we shall present in other columns only what we consider of interest or value to our readers. Advertising matter will not be printed as news.

Advertising rates in THE CIRCULAR are lower, considering the number of tradesmen reached by its large circulation, than in any other jewelry journal.

Notices of changes in standing advertisements must be received one week in advance; new matter can be received up to Monday.

## INFORMATION FOR SUBSCRIBERS.

### Terms of Subscription, Postage Prepaid.

	PER ANNUM.
United States and Canada. . . . .	\$2.00
Foreign Countries in Postal Union, . . . . .	4.00
Single Copies. . . . .	.10

New Subscribers can commence at any time.

Payments for THE CIRCULAR when sent by mail, should be made in a Post-Office Money Order, Bank Check or Draft, or an Express Money Order or Registered Letter. All postmasters are required to register letters whenever requested to do so.

Pay money only to authorized collectors having proper credentials.

**Returning Copies** Returning your paper will not enable us to discontinue it, as we cannot find your name on our books unless your address is given.

**Changing Address.** In changing address always give the old as well as the new one. Your name cannot be found on our books unless this is done.

**Discontinuances.** We will continue to send papers until there is a specific order to stop, in connection with which all arrearages must be paid; but such an order can be given at any time, to take effect at or after the expiration of the subscription. All such orders will be promptly acknowledged by mail.

**Liability.** The Courts have decided that all subscribers to Journals are responsible until arrearages are paid in full and an order to discontinue has been received by the publisher.

## THE JEWELERS' CIRCULAR IN EUROPE.

Among the Places in Europe where THE JEWELERS' CIRCULAR is on file are the following:

**LONDON**—First Ave. Hotel, Holborn, E. C.; Holborn Viaduct Hotel, Royal Hotel.

**PARIS**—Hotel de L'Athéné, Rue Scribe.

**BERLIN**—Deutsche Uhrmacher Zeitung, Jager-Strasse, 73.

**GENEVA**—Journal Suisse D'Horlogerie.

**AMSTERDAM**—Continental Club, Hotel Amstel.

**ANTWERP**—Diamond Club, Rue de Pelicaan.

Vol. XXXII. May 27, 1896. No. 17.

Every line of reading matter in THE JEWELERS' CIRCULAR, with the exception of the few brief extracts from exchanges, always properly credited, is written exclusively for this journal. Each issue of THE JEWELERS' CIRCULAR is copyrighted. Permission to quote is extended to other publications, if such quotations are properly credited.

## A Critique on S. Bing's Critique.

SOME months ago, we had access to a copy of "La Culture Artistique en Amerique," a report by S. Bing, to the Beaux Arts, of Paris, France. At that time, we took issue with Mr. Bing on a few sweeping statements he makes, though the general tenor of his report, so far as we had read it, was then endorsed. In order that a just presentation of Mr. Bing's impressions of American art might be made, as well as to afford the jewelry trade an opportunity to learn what foreign critics think of the manifestations of their native craft, such portions of the chapter entitled "The Industrial Arts," in this *rapport*, as bear particularly upon gold and silversmithing were translated into English, and in this form published in THE CIRCULAR, of May 6 and 20. The impressions of so experienced an art critic as Mr. Bing, embodied in a report to an institution of so high standing as the Beaux Arts, are worthy of deep consideration, as no matter howsoever wide from the truth they may be, they will remain in France as the standard for repetition and reference until the next similar report is made, which, doubtless, will not be until many years hence. In his criticisms on the American productions in the fine arts, Mr. Bing may or may not be sound and rational; it is not for us in our province of producers of a journal representing several branches of industrial art, to judge his conclusions in that connection. His analysis of the relationship between the fine and industrial arts is logical. It is when he treats of particular industries that his reasoning loses in potentiality, through the obviously limited field he has accepted for observation and inquiry. His studies in American gold and silversmithing have been confined to the products of two houses only; it is true he refers to two others, but one of these is a retail house (Spaulding & Co.) and it is evident he did not examine the gold and silver work displayed by either of them. Mr. Bing commits the error common with all foreign visitors seeking impressions of American industry, in considering the house of Tiffany & Co. the fountain head of the jewelry trade. This house is justly one of the features of which Americans are proud; but there are many firms who in their individual lines of manufacture stand as high. With their enormous resources and extensive ramifications, Tiffany & Co. are able to produce unique, experimental pieces in jewelry that win prizes in exhibitions, and eventually find their way to persons with most exclusive æsthetic tastes or with bulky bank accounts. Mr. Bing's course of inquiry and study in American silversmithing was particularly narrow. Silversmithing is one of the established industrial arts of America; in its artistic expression it does yield the palm to the straight-laced, stolid works of the English, the ugly, disproportionate and redundantly ornamented works of the German, or the finical, *soi-disant* poetical works of the French silversmiths. But a proper appreciation of this branch of American industrial art cannot be obtained by an inquiry into the works of two manufacturers. In this industry there

are at least a half dozen manufacturing firms of the first magnitude. Mr. Bing should have studied the products of the Whiting Mfg. Co., of Dominick & Haff, of Geo. W. Shiebler & Co., and of others, many of which are among the finest manifestations of the silversmith's art, before he sent his report to the Director of the Beaux Arts. These houses extend back to the beginning of American silversmithing and their careers have been continuous courses of active and studious endeavor to place their craft upon the highest plane. The silversmithing industry in this country owes its high position to these houses as well as to those mentioned in Mr. Bing's report. It is painful enough to read the periods of the foreign critic who always assumes a superior attitude and mode of expression, no matter howsoever just he may try to be; it is more painful still when these periods are based upon insufficient data and narrow observation.

## The Silver Plate Industry of Canada.

THE benefits to a young country of the policy of protection are well illustrated in the establishment of a silver plated ware industry of considerable magnitude in the Dominion of Canada. The Toronto *Mail and Empire*, in an article published on May 19th,—one of a series upon Canadian industries—gives some interesting details as to the growth and present position of this industry. Until the institution of the protective tariff now existing in the Dominion, there were no silver plated ware factories in that country. Then the American manufacturers looked about for some way to compete with the factories that were projected, and in 1879, Simpson, Hall, Miller & Co., Wallingford, Conn., established a branch factory in Montreal, being soon followed by the Meriden Britannia Co., who built large works in Hamilton, Ont., where they have remained ever since. About 1880 a factory was started at Thorold for the manufacture of flat ware, which was afterwards removed to Humberstone, Ont. In 1883 the Toronto Silver Plate Co. organized, and in 1884 the works now owned by the Standard Silver Plate Co., Toronto, commenced operations. These five factories now do practically all the business in silver plated wares in the Dominion. They represent an investment of about \$500,000, and their annual pay rolls amount, at least, to \$250,000. The number of hands employed in the trade is from 500 to 700. We consider this array of figures reflective of a better condition of affairs among the people of Canada, than would have existed if no protective tariff on silver plated ware had been imposed. In the latter case, prices on this ware might have been fractionally less than now, but there would have been no silver plate industry to lend its aid, with other manufacturing industries, to advance the commerce of the nation.

Stearns & Hearn, Pine Bluff, Ark., have dissolved partnership by mutual consent. R. H. Stearns has purchased the interest of W. D. Hearn and will continue the business under the firm name of R. H. Stearns & Co.

### New York Notes.

A judgment for \$720.22 has been entered against Ernest Adler by A. Wallach & Co.

A Davidoff has filed a judgment for \$135.86 against Julius Plaine.

Isaac Freedman, of Dattelbanm & Freedman, sailed for Europe Thursday, on the *Augusta Victoria*.

Judgments against E. Wertheimer & Co. have been filed by the Ostby & Barton Co. for \$3,764.53, and by F. Esser and others for \$7,476.13.

Goldsmith & Weil, diamond cutters, have moved their office from 1 Maiden Lane to the Lorsch building, 37 Maiden Lane. Their diamond cutting factory, which will soon be opened again, will be situated in Harlem.

Louis A. Housmann, for 25 years in the jewelry business in this city, died suddenly at his home in Hoboken, Friday night, from apoplexy. He was well known in club and social circles in Hoboken. He was 47 years of age. A wife and two children survive him.

The New York Jewelers' Board of Trade have instructed their attorneys, in Butte, Mont., to appeal the case of the Kent & Stanley Co. Ltd against the Tuttle, Dugan Jewelry Co. and test the constitutionality of the Montana law relating to foreign corporations doing business in that State.

The following out-of-town jewelers were registered in New York during the past week: A. H. Wittstein, Chicago, Ill., N. Amsterdam H.; A. Lathrop, Syracuse, N. Y., Astor H.; Mr. Cuthbertson, Toronto, Can., Astor H.; C. D. Palmiter, Watertown, B'way Central H.; E. L. Everett, Washington, D. C., Murray Hill H.

Alfred Joel, formerly a prominent retail jeweler of this city, died of heart failure at his home, 116 E. 59th St., Wednesday night. Two sisters, with whom he lived, survive him. He was at various times associated in the management of many theatrical enterprises of this city. The funeral services were held Sunday morning.

E. Schenck, importer and cutter of diamonds, formerly at 71 William St., has formed a partnership with John Van Haelen, who has worked with him for over 10 years. The business which has been removed to the Merck building, southeast corner of University and Clinton Places, will hereafter be conducted under the firm name of Schenck & Van Haelen.

Newwitter & Rosenheim, jobbers of jewelry, 513 Broadway, whose business recently went into the hands of a receiver, have not yet sent out any statement or called a meeting of their creditors. At the office of Blumensteil & Hirsch, attorneys for one of the partners, a CIRCULAR reporter was told, Friday, that the receiver had not yet completed his report, but that a meeting of the creditors would be called as soon as this statement was ready.

Counsel in the suit of Allan C. Dalzell against the Fahys Watch Case Co., which has been on trial for several months before Hamilton Odell as referee, summed up their case before the referee Saturday. The suit is to recover \$75,000 which, Dalzell alleges, is due

as one half profits on watch crowns made by the Fahys Watch Case Co. under his patents. Edmund T. Oldham appeared for the plaintiff, and Wm. A. Jenner for the defendants.

Dividends were distributed Monday by the New York Jewelers' Board of Trade to the creditors whom they represented in the failures of Geo. H. Kettmann & Co., Louisville, Ky., and C. P. Pittman, Ennis, Tex. The 40 creditors of Geo. H. Kettmann & Co., whom the Board represented, received 33 1-3 per cent. on their claims, 25 per cent. in cash and a note for 8 1-3 per cent. due Feb 1, 1897.

To the creditors of Pittman, \$1,869.55 was distributed, being 25 per cent. of the 17 claims aggregating \$7,478.20 the Board held.

Dr. William Fogg Heath, who died at his home, 246 W. 123d St., of typhoid pneumonia, May 18, was known to many in the jewelry district. Dr. Heath was born in New Bedford, Mass., in 1858, and came to this city when a young man. He studied dentistry, and, after being graduated, practiced for a few years, when he gave up his profession and went into the jewelry business, in which he was employed by the old house of Carroll, Bishop & Co., and later by Wheeler, Parsons & Hayes, Whiting Mfg. Co. and the Gorham Mfg Co.

John Howard Foote, a widely known dealer of musical instruments, died May 17, at his residence, 399 Madison St., from an attack of grip. He was born in Canton, Conn., Nov. 11, 1833, and at an early age came to New York. In 1853 he was employed by Rohe & Leavitt, dealers in musical instruments, 31 Maiden Lane, and nine years later succeeded to the business of the firm. At that time the musical instrument trade found the greater number of its customers among jewelers who carried these goods as a side line and Mr. Foote soon became well known generally throughout the jewelry trade. Mr. Foote opened a Chicago branch in 1868 and both this and the New York house he conducted under his sole management up to the time of his death.

The Appellate Division of the Supreme Court, Thursday, heard the appeal of Wallach & Schiele from a judgment for \$500 recently awarded Joseph Kleb in his suit to recover a reasonable value for their use of over 200 new designs for jewelry articles, alleged to have been originated by Kleb and used by the defendants. Wallach & Schiele in their appeal contend that there is no pretense that they agreed to pay any fixed sum for designs, and, therefore, the plaintiff, if he was entitled to recover compensation, was bound to show the reasonable value of the designs in order to recover. This he did not do, and having failed to do so, was not entitled to any recovery. Kleb contends that he proved that the designs were valuable and that there were very few workmen in the shop before these designs were introduced, and thereafter the force was largely increased, and that all, or nearly all, of the employes were working on these designs. Fettretch, Silkman & Seybel appeared for Wallach & Schiele; Geo. A. Stearns for Kleb. Decision was reserved.

### Trans-Atlantic Voyagers.

#### TO EUROPE.

Among the passengers bound for Genoa last week on the *Werra* were Edmond E. Robert, Mr. and Mrs. J. Eugene Robert, Miss A. A. Robert and Miss E. E. Robert.

Max J. Lissaner, of Lissaner & Co., New York, accompanied by his wife, sailed for Europe, Friday, on the *Augusta Victoria*.

Mr. and Mrs. E. M. Gattle, New York, were passengers on the *St. Paul*, which sailed Wednesday.

Leon Barré, of Tiffany & Co., New York, and L. Hirsch, New York, were passengers on *La Normandie*, which sailed Saturday.

Otto Sinauer, of Oppenheimer Bros. & Veith, New York, sailed Wednesday on the *Friesland*.

#### FROM EUROPE.

H. Ryrie, Ryrie Bros., Toronto, Can., returned on the *Britannic* last week.

Geo. E. Fahys, of the Fahys Watch Case Co., New York, is expected home from Europe Friday on the *Columbia*.

### Trade Gossip.

The "Diamond Dee" skirt grip, just brought out by Deitsch Bros., 7 E. 17th St., New York, has already met with a very large measure of success. The firm are now producing them in many handsomely chased designs, as well as in some beautiful rhinestone patterns set in sterling silver.

Ryrie Bros., Toronto, Ont., have, with their usual and characteristic enterprise, taken the sole agency for the Rogers Statuette Co.'s goods in Canada. The latter company are especially fortunate in their choice of representatives, and Ryrie Bros. have got a good thing in the sculptured art goods put forth by the Statuette Co.

The self-healing tire is one of the recent most valuable additions to cycling improvement, possessing the wonderful ability to instantly heal any ordinary puncture. This fact will prove of great interest to all lovers of the bicycle, as punctures have hitherto been the source of considerable trouble. There will be no more worry on this subject in the future, if self-healing tires are on the rim.

Among the many beautiful belts which have recently been put on the market by Bippart & Co., Newark, N. J., deserving of special mention are those with silver buckles decorated with enamel centers, in a great variety of artistic designs. An absolutely new feature in belts which Bippart & Co. are introducing, is ribbon with edges of various colors which produce a very pleasing effect. The handsome line of leather belts which this firm are showing includes many patterns mounted with sterling silver buckles, very rich and heavy, in elegant rococo designs, and with oxidized and old gold finishes and with colored enamels. The "Lorraine" belt retainer, for which this firm have applied for a patent, is a very simple and effective device. It is made of sterling silver in a number of graceful styles.

## Special Notices.

Rates 75c. per insertion for notices not exceeding 3 lines (25 words); additional words 2 cents each. If answers are to be forwarded, postage stamps must be enclosed. Two insertions, 15 per cent. off; three insertions, 20 per cent. off; four insertions or more, 25 per cent. off. Payable strictly in advance. Display cards on this page will be charged at \$2.00 per inch for first insertion, subject to same discount as above for subsequent insertions.

Under the heading of **Situations Wanted** on this page advertisements will be inserted for **One Cent a Word** each insertion, no discount. This offer refers to **Situations Wanted only**. Payable strictly in advance. If answers are to be forwarded, postage must be enclosed.

## Situations Wanted.

Notices under this heading **ONLY** are charged at **one cent a word**, payable strictly in advance. If answer are to be forwarded, postage must be enclosed.

**FIRST-CLASS LAPIDARY** with tools and benches is open for engagement. Address T. W. G., care JEWELERS' CIRCULAR.

**WANTED.**—Position by young man, 8 years' experience as watchmaker and salesman; am a competent watchmaker; best of references. Address Lem Clarke, 328 Whitehall St., Atlanta, Ga.

**OPEN FOR AN ENGAGEMENT**, by a first-class watch repairer and good engraver, capable of taking charge of store; own tools, highest of reference. Address X Ray, care JEWELERS' CIRCULAR

**FIRST-CLASS DIAMOND MOUNTER**, setter; also general manufacturing jeweler wishes permanent position; sober, industrious; A1 references; 20 years' experience. Address E. F. M., care JEWELERS' CIRCULAR.

**FIRST-CLASS WATCHMAKER** and optician desires permanent situation with reliable house; 28 years' experience; capable of taking charge of store; own tools and trial case. Address C. F. Baldwin, 404 Main St., Keokuk, Ia.

## Help Wanted.

**WANTED.**—Young man, desirous to improve himself in chronometers and fine watches. Apply to H. H. Heinrich, 102 Fulton St., New York.

**WANTED.**—Experienced traveling salesman to sell watches to the trade in the city and nearby towns; must have the best references. Address Watches, care JEWELERS' CIRCULAR.

## Business Opportunities.

**FOR SALE.**—Entire stock of jewelry, diamonds, watches and fixtures; good location and business in Hartford, Conn. Address H., care JEWELERS' CIRCULAR.

**ONLY JEWELRY STORE** in growing manufacturing town in New York; weekly pay roll averages \$10,000; poor health reason for selling. Address A. B., care JEWELERS' CIRCULAR.

\$1,200 will buy my 6,800 lb. steel-lined safe, plateglass store fixtures and balance of my clocks and silverware; will sell watches and jewelry if wanted; best opening in Oklahoma for a live jeweler. Chas. E. Rose, El Reno, Oklahoma.

**FOR SALE** in Philadelphia, a desirable business in a fine locality; clean stock about \$8,000, which can be reduced if desired; walnut fixtures, fine regulator, safes, etc; good run of work; established 12 years. Address O. E., care JEWELERS' CIRCULAR.

**SPLENDID CHANCE** for young man with small capital, in live town in Southside, Virginia; market place for six counties; five large tobacco warehouses; store excellently located; rent low; safe and other fixtures included. Address Mrs. Otto Salzman, Danville, Va

\$650 00 **SPOT CASH** buys fixtures, material and optical goods of leading jewelry and optical store; established 15 years; western New York; bench work \$1,500 per year; only optician; will sell any other part of stock if desired. Address J. O., care JEWELERS' CIRCULAR.

## To Let.

**TO LET**—A good office on the third floor in the Diamond Exchange Building, 14 Maiden Lane, N. Y.; now occupied by the Fletcher Watch and Jewelry Co. This office will be rented very low to May 1, 1897. Apply to Janitor, or Smith & North, 14 Maiden Lane, N. Y.

## For Sale.

**FOR SALE.**—A Marvin fire-proof safe; outside width 54 inches, height 65 inches, depth 28 inches. R. A. Loveland, 177 Broadway, N. Y.

**CHEAP**—Five burglar and fire-proof safes; handsome solid black walnut glazed office partitions, tables and other fixtures; also complete set of jewelry trunks. Max Freund & Co., 8 Maiden Lane, N. Y.

## FOR RENT.

Large Office, **Corbin Building**, 5th Floor --

Will let very low for **Three Years.**

APPLY, - - - -

**JOSEPH FAHYS & CO.,**  
NO. 54 MAIDEN LANE, N. Y.

## TO RENT.

Back office, first floor, 20x40, new store building, 9 East 16th St., New York. All modern conveniences; fine light, suitable for silversmith or jewelers; rent very moderate.

**EDWARD TODD & CO.**

**WOOD & HUGHES,**  
**STERLING SILVERWARE MANUFACTURERS**  
New York Agents for the Derby Silver Co.,  
**FINE QUADRUPLE PLATED WARE,**  
No. 16 JOHN STREET, NEW YORK  
206 Kearney St., San Francisco, Cal  
**HASKELL & MUEGGE, Agents.**

**SECURITY PIN GUARD**  
PAT'D DEC. 25, 1894  
MANF'D BY SECURITY MFG CO. **25¢**  
**7 ASTOR HOUSE (BROADWAY) N.Y.**

85c. doz. Net Cash. Discount to Jobbers

**SEND FOR CATALOGUE** of books for the jewelry and kindred trades. Just issued. JEWELERS' CIRCULAR PUB. CO., 189 B'way, N. Y.



of the Best Quality, which are offered to Jewelers of recognized standing only.

Trade Mark "SILVER WHITE," registered.

## STERLING SILVER SHIRT WAIST SETS.

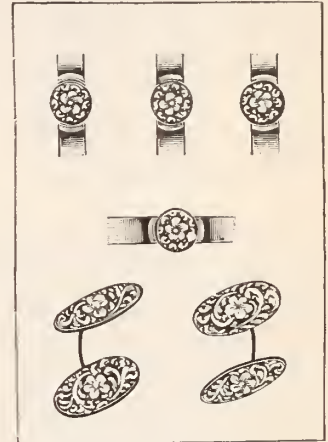

Cut 1/2 actual size.

Guaranteed .925 Fine.

— **ONLY \$3.50 PER DOZ.** —

12 different styles at this price.

This is undoubtedly the best article in the market for the money. Every button has an extra piece of silver soldered on the rim, so as to add to its style, finish and durability, and is not a mere shell like most of the low priced waist sets on the market. We also have these goods in extra heavy, bright cut, chased patterns, at \$4.50 per dozen, and in silver, enameled, with or without Roman finish from \$7.50 to \$15.00 per dozen.

**BIG LINE OF LEATHER BELTS.**

S. C. POWELL, Sterling Silver Novelties,

51-53 MAIDEN LANE, N. Y.

**JOHN T. PECK,**  
**WATCHMAKER**  
— FOR THE TRADE. —

409 WASHINGTON ST.,  
Room 15. BOSTON, MASS.

**PHOTO-MINIATURE.**  
**PORTRAITS \$1.50**  
ON  
**WATCHES**  
The Goldstein Engraving Co.,  
1 MAIDEN LANE, NEW YORK, N. Y.

## THIS TRADE MARK....



on cut glass is a guarantee of superior quality. Designs all new and original. Libbey blanks used exclusively. Send for catalogue.

**STANDARD CUT GLASS CO.,**  
545-547-549 W. 22d St., New York.

**IT IS A FACT**  
**THAT**

The Jewelers' Circular

publishes all the news and represents every branch of the jewelry industry

\$2 Per Year. 4 cts Per Week



**The STATIONERS' ENGRAVING CO.,**  
98 TO 102 NASSAU STREET, NEW YORK.

MAKERS OF

WEDDING INVITATIONS, RECEPTION AND VISITING CARDS

THE STAR OF EMPIRE WESTWARD TAKES ITS WAY!

# WESTERN SUPPLEMENT

## of THE JEWELERS' CIRCULAR

Chicago Office: Room 517, Inter-Ocean Building.

VOL. XXXII.

CHICAGO, WEDNESDAY, MAY 27, 1896.

NO. 17.

### Chicago Notes.

Byron L. Strasburger, New York, was a visitor here the past week.

A. L. Sercomb, of the Meriden Britannia Co., returned Thursday from a visit to the factory.

Jo Ayres, of T. R. J. Ayres & Sons, Keokuk, Ia., will be married June 4 to a prominent lady of that city.

Jo Crawford, H. F. Hahn & Co., is back from his early trip. Ed. Hoffman, of F. C. Happel Co., is expected in a few days.

In a fire at Blue Island, recently, the jewelry store of John Schroeder was burned out; loss, store \$2,000, insurance \$1,000; jewelry loss \$500, no insurance.

Louis Strasburger's Son & Co., have moved their Chicago office from 34 to 38 Washington St., to the Columbus building, 103 State St.

J. H. Rogers, Gridley, Ill., was a buyer here the past week. August Bruder, Fort Wayne, Ind., and E. J. Peck, Braidwood, Ill., were also noticed.

C. P. Dungan, C. A. Barnum and W. C. Wood, of the Meriden Britannia Co., having finished their Spring trips have returned to the salesroom for the Summer.

The Juergens & Andersen baseball team are anxious to get games with jewelry houses for Saturday afternoons. Those who think they can "do the trick" can call on O. R. Hirt, 125 State St., and secure dates.

Rupert Alfred Kettle, Chicago manager of the American Waltham Watch Co., and Georgiana, daughter of Mrs. George W. Champlin, will be married at Trinity Church, Chicago, at 12.30 o'clock, June 2d. Mr. Kettle is one of our most prominent young business men and is a leader also in social life. The charities of the bride-elect are well known throughout the city. Mr. Kettle has just completed a very handsome brown stone residence at 4342 Drexel Boulevard, where the couple will be "at home" after Sept. 1st. Mr. and Mrs. Kettle immediately after the wedding will make a tour of New York and the eastern resorts, returning the latter part of the month.

Benj. Allen denies the statement made in a Chicago daily that Spaulding & Co. had leased the lower five floors of the new Silversmiths' building, to be constructed the coming Summer by Mr. Allen and others. Benj. Allen & Co. will occupy the fifth floor of the structure

when completed; the Gorham Mfg. Co. will have the sixth floor, F. A. Hardy & Co. the seventh, and Simpson, Hall, Miller & Co. have practically settled on securing the eighth. The floor above this will be divided up according to tenants' requirements, while the lower four will be leased to one party if possible. Spaulding & Co. spent \$10,000 in fitting up their store at State and Jackson Sts. and are well satisfied with this location. The dry goods house of A. M. Rothschild would undoubtedly like the entire block on State St. from Van Buren to Jackson Sts., and the securing of the Spaulding corner would give it to them.

### Kansas City.

H. N. Meyer has gone east for a few weeks' stay.

D. Finkelstein has opened a jewelry store at 12 E. 12th St., where he has a very good location and fine fixtures.

Henry Porter, with Edwards & Sloane Jewelry Co., is spending a few weeks fishing in Arkansas.

The out-of-town buyers here last week were: B. R. Smithers, Cameron, Mo.; Jno. Gingrich, Moberly, Mo.; W. H. Meyer, Lawson, Mo.; B. Hoffman, Leavenworth, Kan.; J. B. Lowe, Independence, Mo.; E. L. Sloan, Wamego, Kan.; J. P. Kelley, Marshall, Mo.; W. S. Beasley, Rich Hill, Mo.; Geo. Essig, Plattsburg, Mo.; C. D. Farnham, Brunswick, Mo.

### Minneapolis and St. Paul.

Judge Russell, of the District Court of Hennipin county, a few days ago signed an order discharging J. A. Young as assignee of the Harry F. Legg Jewelry Co., Minneapolis, who assigned two years ago. The estate has been entirely settled. The report filed shows the claims against the company of \$4,047.92 to have been paid in full, besides the paying of the account of the assignee and his attorney. The estate, it is said, yielded considerable to the company.

The tower clock in the new City Hall and Court House building, Minneapolis, has just been completed, and started running on the morning of the 21st inst. This clock is one of the largest in the world, the dial being 22 feet and four inches in diameter, made of ground glass, and illuminated at night by electricity. The minute hand measures 11 feet and the hour hand 7½ feet. The clock is connected with one of the largest and finest

set of chimes of its kind in this country, and will strike the hours, quarters, halves and three-quarters automatically.

Leslie C. Lane, assignee of the Reed & De Mars Jewelry Mfg. Co., Minneapolis, appeared in the District Court before Judge Belden, on the 18th, and asked for the allowance of his final accounting of the estate. The account was allowed as presented, the assignee being allowed \$1,000 for his services, and his attorney, C. B. Holmes, a like amount. The estate will pay 28 cents on the dollar. The court held that the assignee will not be discharged until such time as he can show the court that the order for distribution made on above date has been complied with. Mr. Lane has been busy this week sending out the checks on the basis of 28 cents on the dollar on claims.

### St. Louis.

A slight but perceptible improvement is noted this week in the retail trade.

A. Kurtzborn, Jr., of A. Kurtzborn & Sons, will be married on June 1st, and not on June 24th, as previously announced.

Louis Bernheim, of Bernheim, Cohen & Beer, New York, was here last week. He was not enthusiastic over the state of trade.

Another "topaz diamond" store has been established on Olive St. This new concern has pulled the price of these "gems" down to 50 cents each.

Morris Bauman, of the L. Bauman Jewelry Co., was seen by THE CIRCULAR man last week. He voices the universal statement in saying that trade is very dull. He says he hopes the convention will enliven things a bit.

The stock and fixtures of the C. Boehmer Jewelry Co. were sold on May 21 to Wm. A. Gill, 616 Olive St. The price paid was \$6,000. The assignee will be enabled to pay the preferred creditors in full, and to the balance 30 cents on the dollar. Wm. A. Gill commenced selling the stock at continuous auction on the 23d.

Among visitors the past week were: Isaac Ettinger, Keller, Ettinger & Fink; Mr. Dinkelspiel, Koch, Dreyfus & Co.; Mr. Goldsmith, Leopold Weil & Co.; Mr. Marshuetz, Julius King Optical Co.; Mr. Kent, Wm. H. Ball & Co.; Alvin Strasburger and Sol. Kaiser, L. Strasburger's, Son & Co.; Charles Boynton, Wm. B. Kerr & Co.; Harry Bliss, Krementz & Co.; Joseph Beach, Wilcox Silver Plate Co., and Benj. Eichberg, Eichberg & Co.



**Pacific Coast Notes.**

J. D. Bennett, watchmaker and jeweler, has located in Biggs, Cal.

L. G. Henrichsen is holding a special 60-days' sale in Portland, Ore.

A. W. Mayers, Watsonville, Cal., has moved his jewelry store into the Alexander block.

E. W. Wright, Rosedale, Cal., has bought out J. G. McAlpine's jewelry establishment, Bakersfield, Cal.

Louis Dorais, optician, who is now located at Eureka, Cal., will return to Nevada City, Cal., this month.

C. H. Leggett, Merced, Cal., has filed a petition in insolvency. Mr. Leggett's principal creditors are in San Francisco.

J. Beck, Provo City, Nev., has moved his stock out of a local drug store, and is now nicely located in an elegant new store.

W. H. Fredrick, who recently visited Alaska, has returned to Portland, Ore., and reports his sales in jewelry fairly successful.

Carl King, Kerdrick, Idaho, has purchased the jewelry business of L. A. Kerr, and will continue the business in the White block.

In a recent fire in the T. D. Mott block, Los Angeles, Cal., the store of Ed. Gerson, jeweler, was damaged to the amount of \$1000.

Albert Feldenheimer, a leading jeweler of Portland, Ore., will visit eastern cities in July to lay in extensive stock for his new store now being erected.

Y. H. Boudreau, who recently opened a jewelry store in Redding, Cal., has returned to his old home in Modesto, Cal., where he will open a new store.

The stock of the insolvent jeweler, O. M. Campbell, Petaluma, Cal., had been bid in by J. S. Blackburn for \$2,005, and the business will be resumed at the same place by Campbell himself.

Memhard & Miller, Spokane, Wash., have purchased the stock of jewelry belonging to the Steinmetz Jewelry Co., Helena, Mon., and after holding a short sale will move the balance of the stock to their Spokane establishment.

Detectives have captured one of the thieves who broke into a box car at Saugus, Cal., April 20th, and secured a large amount of silverware valued at from \$700 to \$1,000. About one-half of the stolen property has been recovered.

A. Kaiser, jeweler, has petitioned the trustees of Sonora, Cal., for protection for the

home jewelers. He wants the license tax on peddlers raised from \$5 a month to \$100. The matter has been referred to the City Attorney, who will draft an ordinance.

Carl Entenman, jeweler, Los Angeles, Cal., has brought suit in replevin against Constable Goodman in the township justice's court. Goodman found in Entenman's establishment five diamonds, which he claimed belonged to Major Truman, whose house was burglarized recently and which he kept.

**Detroit.**

C. Baxter, Birmingham, Mich., purchased goods here last week.

A. F. Clark, jeweler and optician, has opened a store in Whitney's bazaar, Lyons, Mich.

J. W. Corley, formerly with Charles Stark & Co., Toronto, Ont., has taken charge of the watch repairing department of Hugh Connolly.

E. F. Hirschgessner, Tecumseh, Mich., announces that he will shortly go out of business. He is holding an auction sale of his stock.

George W. Shellman, whose store in Kalamazoo, Mich., was robbed, was compelled to purchase an entire new stock of optical goods. There is no clue to the burglars or the goods.

Flint, Mich., police last week arrested a gang of hobos, who had a large quantity of jewelry in their possession. The jewelry was new and consisted of finger rings, chains and earrings.

Wright, Kay & Co. have converted one of their show windows into a Russian window. The flag of that country forms the background and intermingled with a large number of fine "Views from Moscow" are samples of Asiatic jewelry, novelties, etc. The whole produces a fine effect.

**Indianapolis.**

While Mr. Foster, of Unger Bros., was in the city last week, he was given a bicycle party by George Sloan. Mr. Foster and Mr. Sloan are planning a trip abroad on their wheels this Summer.

While Joseph Jefferson appeared as Bob Acres in "The Rivals" a Rogers statue of "Fighting Bob" occupied a prominent place in J. C. Walk & Son's window and attracted much attention.

Cards have been issued for the marriage of Joseph Edward Reagan to Miss Florence Wood

**THE PERFECTION SHOW CASE**

FOR FINE JEWELRY TRADE.

WE CHALLENGE THE WORLD TO PRODUCE ITS EQUAL.



IF YOU ARE INTERESTED IN SHOW CASES AND JEWELRY FURNITURE, WRITE US FOR FULL INFORMATION.

**A. H. REVELL & CO.,**

431 to 437 Fifth Avenue, Chicago.

EST. 1870. DR. PETER HENRY, SPECIALIST IN Watch Case Diseases



Key Winders changed to Stem Winder.  
Hunting Case changed to O.s.  
English Case changed to fit American movements.  
Can be cured at  
53 LONGWORTH ST., Cincinnati, Ohio.

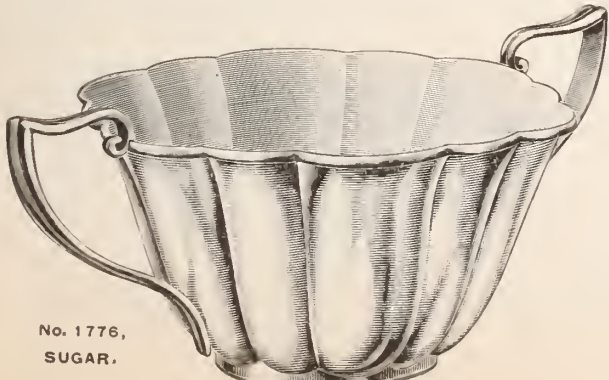

No. 1776, SUGAR.

**Sterling Silver Table Ware.**

**TOWLE MFG. CO.**

NEWBURYPORT, MASS.

CHICAGO.

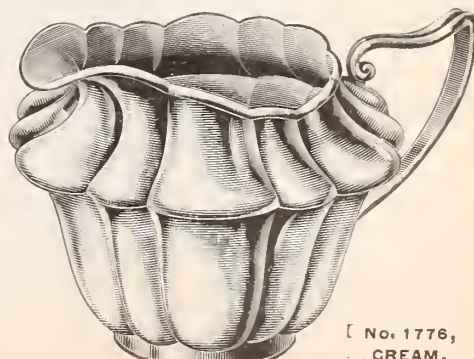

No. 1776, CREAM.

ward, at Roberts Park Church, June 3. Mr. Reagan is the youngest member of the firm of Baldwin, Miller & Co.

W. F. Kattman, Poland, Ind., and A. Hawkins, Noblesville, Ind., were seen at the wholesale houses last week.

Among the guarantors of the annual May Musical Festival Fund are E. C. Miller, J. C. Sipe and Julius C. Walk & Son.

**Louisville.**

THE CIRCULAR of April 15th stated that G. A. Stein had bought the retail jewelry store owned by George H. Kettmann & Co., whereas it should have been G. A. Stein & Bro. H. H. Stein, traveling auditor for the Standard Oil Co., is a half partner in the business.

H. C. Korfrage says he is the first jeweler in Louisville who handled bicycles several years ago. He thinks of closing out his jewelry store on 4th St. and going into the bicycle business exclusively.

Geo. H. Kettmann has made a settlement with his creditors and resumed his business. He thinks, however, he will in a few months leave Louisville for either Chicago or St. Louis.

George H. Casperke, Brandenburg, Ky.; Mr. Cooper, Hodgenville; J. B. Settle, Bowling Green, Ky., and Mr. Conn, Charlestown, Ind., called on the wholesale jewelers here last week.

One of the handsomest jewelry stores in Louisville is that of Jas. K. Lemon & Son,

who had an opening in their new quarters on 4th St. last Monday. Invitations were issued and a large crowd was present. The fixtures are of solid mahogany and rosewood and extend the entire length of the store on either side and into the show windows. The front compartment, on the right, is the diamond room, which is encased in beveled glass and mahogany. On the left is a similar compartment for the optical department, which the firm have conducted for many years. The floor is of handsome mosaic, while the papering is in the popular Delft blue. The vestibule contains the firm name worked in Parian marble mosaic. Mr. Lemon came to Louisville in 1828, and was with Wm. Kendrick until 1842. In 1862 he associated with him his son and the firm became J. K. Lemon & Son, which continued till '69. Jas. K. Lemon then succeeded his father and admitted his son as partner in 1889.

**Cincinnati.**

John Osthoff, of Jos. Noterman & Co., writes from Paris that the diamond market is very brisk. Even small stores sell head ornaments for \$800 to \$1,000. He expects to tour through France and Italy.

Miss Charlotte Duhme, daughter of the late Herman Duhme founder of the old Cincinnati house, will be married June 4th to Chas. B. Eustis, of Eustis Bros., jewelers, Minneapolis.

John Smith, the veteran Main St. jeweler, who has occupied the same stand for the past

quarter of a century, has decided to keep up with the times and is putting in a new modern front to his store.

Jos. Sauer has opened a new store on Vine St.

Joe Phillips, of Bloom & Phillips, is in the northwest and has sent in the best orders they have had this season.

S. B. Harding, Seymour, Ind., who has been at the same place since 1860, is remodeling his store and improving its appearance.

A conference is to be held in Cincinnati the coming week of the leading commercial men for the organization of a credit association. The local body will be known as the Cincinnati Credit Men's Association.

There is on exhibition in Duhme's window this week a magnificent loving cup in Rookwood ware, to be given to the Rev. Dr. Rainsford, of New York, by the Episcopal fraternity of this city, as a token of their appreciation of his services during his stay with them some time ago.

Oskamp, Nolting & Co. will make a gold medal and present it to the Walnut Hill High School, to the pupil making the best record in mathematics. The Seegal medal, to be given by Mrs. Seegal to the same school for the best thesis in English literature, was made by Jos. Noterman & Co., and cost \$85.

The May Festival brought a good many jewelers to town last week. Among them were: H. J. Burt, Liberty, Ind.; E. Devoss, Wilmington, O.; Mrs. W. C. Ward, Winchester, Ky.; W. M. Hinton, Paris, Ky.; H. A. Ross, Cynthia, Ky.; Chas. Haynes, Henn & Haynes, Chillicothe, O.; Judd Williams, Urbana, O., and Herman Smith, of Parkersburg, W. Va., who has been to Chicago on business but stopped over en route home.

This is the Festival week and the whole town has taken on a festive air. The leading jewelry firms show some of the prettiest decorations. The National colors and cedar garlands embellish the front of all the stores. The Loring Andrews Co., successors to E. E. Isbell & Co., have the most elaborate display. Long ruby velvet portieres fastened at the top of the doors at the front entrance with a golden lyre are draped at either side and at the base are two huge golden vases with dwarf cedars. Garlands of smilax and long pieces of tapestry hang from the upper windows.

NEVER BLOTS ADJUSTABLE ALWAYS READY.



**The Whitney Adjustable Fountain Pen.** The only pen made using adjustable feed to regulate the flow of ink.

**EVERY PEN GUARANTEED** and money refunded if not satisfactory. Retailers from \$1.75 to \$5.00. Write for catalogue and discounts to dealers.

R. W. WHITNEY, - CLEVELAND, O.

**PARSONS & SCHOOL**

—FOR—

**WATCHMAKERS,**

PEORIA, - - - - - ILL

Send for Circular and Terms,

**PARSONS & CO.**

**THIS ADV. IS WORTH MONEY** When cut out and sent with an order to the amount of \$5.00 or more, it is good for 25c. in payment. On an order for less than \$5.00 is good for 10c.

**COLUMBIA BICYCLE BELT,**

Pebble, Tan, Pig Skin, Dark and Brown Russia, Bok, etc.

made in Black, Brown and Green Seal or Brown and Green Imported

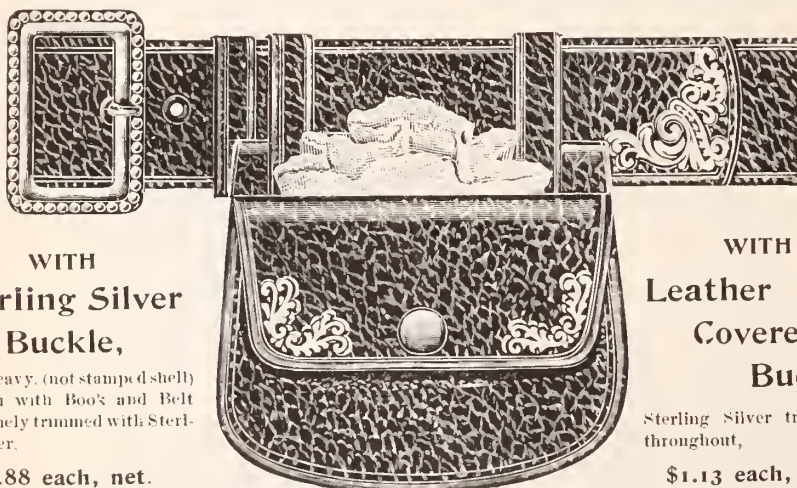

**WITH Sterling Silver Buckle,**

extra heavy, (not stamped shell) 1 1/2 inch with Boo's and Belt handsomely trimmed with Sterling Silver.

\$1.88 each, net.

**WITH Leather Covered Buckle,**

Sterling Silver trimmings throughout,

\$1.13 each, net.

1 1/2 inch Belt, special grain, leather covered buckle, plain round corner chatelaine, belt and book trimmed in Sterling Silver, special at 88c. each, net. We have a Special Line of 1 1/2 inch lined belts with leather covered buckles to match, at from \$1.50 to \$5.50 per doz.

Same, with sterling silver trimmings, at from \$6 to \$9 per doz.

We manufacture these goods throughout from raw material, hence the extra values.

—ORDER SAMPLES AND ILLUSTRATED SHEET.—

THE **O. E. BELL CO.,** Manufacturers, Cincinnati, Ohio.

# IMPORTANT.

## The United States Circuit Court of Appeals

has decided that the Colby patent for pendant setting Watch Cases is invalid, and from this decision there is no appeal.

We are, therefore, the only manufacturers and ours the only valid pendant set device used in the manufacture of pendant setting Watch Cases.

In answer to some inquiries made of us, we wish to say we do not manufacture a pendant setting Watch Case for the new model 16 size Elgin Watch movement.

**The Dueber Watch Case Mfg. Co.,**  
CANTON, OHIO.

A Western customer writes under date of March 25, 1896: "The time for making Class Pins is approaching and we have had several calls this week. Please send us circular of your very *Latest Designs in Class Rings* and quote prices and we will make an effort to get some orders."

Requests for "up-to-date" Designs promptly sent to Jewelers with estimates.

**Henry C. Haskell,**

MAKER,

11 John St., New York.

**A. J. COMRIE,**

AUCTIONEER,

22 John St., N. Y.

SPECIAL SALESMAN OF WATCHES, DIAMONDS.  
BRIC-A-BRAC, FOR ESTABLISHED JEWELERS.

WRITE FOR PARTICULARS

## KETCHAM & McDOUGALL,

MANUFACTURERS OF

GOLD AND SILVER

**THIMBLES**

ESTABLISHED 1832.

**M & D**

TRADE-MARK.

And the improved

**Automatic Eye-Glass Reel.**

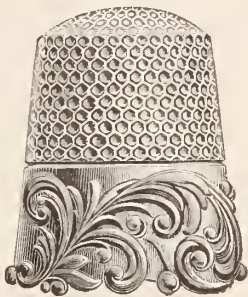

No. 149

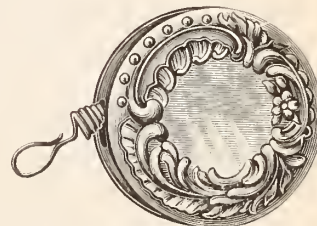

Pat'd Nov. 20, '94.

SEND FOR  
CATALOGUE C.

198 BROADWAY, NEW YORK.



MANUFACTURERS OF FINE

**JEWELRY**

AND  
NOVELTIES

IN GOLD AND SILVER.

355 Mulberry Street.

Newark, N. J.

DEPARTMENT OF  
**ADVICE AND CRITICISM**  
 ON  
**RETAIL JEWELERS' ADVERTISING.**

BY ALFRED MEYER.

[This department is absolutely free to every retail jeweler and optician. Forward for criticism your newspaper ads., booklets, catalogues, novelties, circulars, etc. Ask advice and offer suggestions. Replies in these columns are unbiased. Please make letters as brief as possible. Every letter and ad. sent will receive full attention, though the publication of the matter may sometimes be delayed a week or two. Address letters and other matters to The Jewelers' Circular Pub. Co., 189 Broadway, New York.]

PART XV.

**NOTICE** that jewelers' advertising is falling off in some parts of the country. I attribute this mainly to force of habit, because it shows that these jewelers do not know what advertising means. Advertising is a method for communicating to the public what your business is, what your goods are and how much these goods may be bought for. Noting so much spasmodic advertising, I would infer that most jewelers believe that the public wish to buy jewelry only about Xmas-time. If the jewelers really believe this, they are greatly mistaken. The people need continually this or that thing sold by the jewelers. If it is not only ready-made goods they need, but articles made to order for birthdays, weddings and festivities. They want repairing done. They need eyeglasses at all times. At the present moment they need shirt waist sets, buckles and belts, chains and silver novelties. The majority of the people are ignorant; they do not know that jewelers keep these articles, but do know that the department stores advertise these goods extensively, especially at this time of the year.

The main part of this article is intended to give sufficient argument to urge jewelers to advertise continuously. Use a small quantity of the best quality newspaper space and put in it effective selling talk. This done constantly will bring customers to your house, and ultimately keep them from the department stores.

There may be instances where a shopper for the sake of curiosity only, responds to your shirt waist set ad. Good salesmanship is in demand then, to turn the curious one into a buyer. Try to sell her something; show what is appropriate but inexpensive in the form of a birthday or wedding gift, and the chances are that you will sell more than the shopper intended to buy.

I am far from trying to persuade the jeweler to spend more money in the newspaper than he did the year previous. What, however, I

advise is that jewelers divide their last year's advertising expense, so that at least the firm's name will constantly be before the public eye.

\* \* \*

**AMBROSE KENT & SONS**, Toronto, Canada, sent a 16-page monthly, 10½ x 13½ inch. It is titled "Ambrose Kent & Sons' Monthly, a journal devoted to art and decoration." It is issued by this house's mail order department, and is delivered for the subscription price of 50 cents a year. Before me I have its very first issue, dated "Toronto, March 12, 1896." L. H. Luke, the firm's advertising manager, writes on the first page a very good article entitled "A. K. & Sons' Palatial Jewel House," outlining everything regarding the house in a pleasing manner. He tells how the house originated, how it prospered and what it now is. Mr. Luke writes in a bright, convincing and instructive style. The second page of the monthly contains poetry and humor and an ad. written about A. K. & Sons' business. The third page speaks about "The Diamond." The following 13 pages contain systematically arranged cuts and prices of almost everything the store carries.

The monthly, if mailed to the right class of people, ought rapidly to increase A. K. & Sons' mail order department. It is certainly good, helpful advertising. I would advise A. K. & Sons to use different cuts and different prices in all succeeding issues of the monthly.

\* \* \*

**I** HAVE the second number of "Ambrose Kent & Sons' Monthly," dated Toronto, Can., May, 1896. It is a 16 page, 10½ by 13½ paper, and contains, with illustrations, the goods sold by this progressive jewelry firm. The first page gives an interesting sketch of "Jewels;" it speaks mainly of the diamond. The story is so well told, without superfluous words, that any reader must feel confident that what Kent & Sons say about the diamond is true. Funny sketches add to the interest of the

paper, but of most importance are the illustrations with prices attached, a good description being given of every article. Represented are almost every branch of the house, for example: the diamond and other rings, useful necessities for young and old, silver novelties, watches, forks, spoons and knives, flatware, optical goods, chains, blouse sets and belts. All in all the paper is well gotten up, and there is every reason why it should bring good returns for the mail order department.

\* \* \*

**THIS** ad. sent by D. F. Sullivan jeweler, Rockford, Ill., I consider very good. Evident-

## Appearance Don't Count. . . .

Even a name has ceased to carry weight with it.

Once anything with "sterling" on it could be relied upon.

That was before some stores became the dumping ground for all the "cheap" jewelry made.

Now you're at the mercy of the seller. Then why not buy of dealers you know are all right.

Ladies' Shirt Waist Sets, 4 buttons and cuff links, warranted sterling silver, hand-chased, Rocco border, usually sold for \$1.50, our price..... **75c.**

**JEWELERS ONLY**—not to be found in other stores.



**D. F. SULLIVAN, . . .  
 Jeweler.**

ly a man with common sense, a man that knows how to write a business-bringing advertisement, wrote the ad. I do not know the series of D. F. Sullivan's ads., but if they all compare with this one Mr. Sullivan's advertising must surely prove profitable. I would be pleased to see more printed matter issued by this jewelry firm.

**I**N the *Republican*, of Rockford, Ill., of April 14th, appeared this ad. No doubt all who

## Grand Opera in Chicago will close with a GRAND UPROAR IN ROCKFORD

As a representative citizen, I rise to protest against our people going to Chicago and buying \$10 seats at the Auditorium—and leaving the balance of their coin there also. They come back badly demoralized as to their financial condition, and we hard pushed taxpayers who put an advt. in every entertainment program, get out and shoot off fireworks in season and out, and shoot off our mouths regularly, all get sadly left.

I have solved the problem and will present grand opera in Rockford at 10c. a ticket. Have leased Haskell park for the season.

Band contests between the Peatonia Buglers and Ridott Wind Jammers each afternoon.

Grand Water Carnival in the park fountain.

Speeches by anyone who wishes to orate.

Mademoiselle De Schemerhorn, the pride of South Rockford, will ride fourteen horses around the block. Positively the only lady on earth that dare handle 'em barehanded. All "keep off the grass" signs will be removed. Go and enjoy yourself.

I have thought of making a speech from the top of a citizens' telephone pole and explain how I sell jewelry so cheap, but have decided to stay in the store and rake in the money. I don't think after all, that I can attend the show at all. Keep the ball a rolling.

**N. E. Benoit, The Aristocratic Jeweler.**

read it spoke about it, but there is a question in my mind whether it brought any business. I should think that if Mr. Benoit, with a good selling argument, would have utilized the same space offering cut prices, described well his goods, his business would have brought larger cash returns.

\* \* \*

### Recent Good Ads.

[Under this heading will be reproduced good ads. (introductory portions only) culled from various sources]

Springfield, Ill. J. C. Klaholt.

## Commence- ment Gifts

A large and finer line of goods suitable for Commencement Gifts has never been displayed in the city of Springfield than is comprised in our magnificent stock. They are suitable for either lady or gentleman, and the large variety makes an appropriate selection. Please call and verify statements.

**The Latest Patents.**

ISSUE OF MAY 19, 1896.

**560,199. CUFF BUTTONER.** LEWIS F. EARL, Philadelphia, Pa., assignor to Simons, Bro. & Co., same place.—Filed Sept. 3, 1895. Serial No. 561,220 (No model.)



As an article of manufacture, a cuff-buttoner composed of a unitary piece of metal bent to form a pair of spring-tongs A, B, having thin flat rounded edges and united at the rear by the flattened rounded yoke E, adapted to be passed through the buttonholes of the cuff, one of said tongs having a flat plain surface adapted to receive one link of the sleeve-button, and the other having a stamped-up tongue forming a recess for the shank of the sleeve-button link.

**560,337. WAIST AND SKIRT SUPPORTER.** JOHN M. ANCK, Philadelphia, Pa.—Filed Feb. 24, 1896. Serial No. 582,393. (No model.)

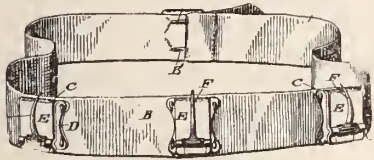

A garment supporter, consisting of a belt having secured thereto a series of supporting devices c, each of said devices being composed of a plate, provided with an elastic limb, integral with the upper end of said plate, and depending therefrom across the face thereof, the lower end of said limb having journal-bearings thereon, and an opening therein, between the said bearings and a hook with journals mounted in said bearings and having a heel passing through said opening and in contact with said plate, the said hook being adapted to bear backwardly against the said limb.

**560,402. EGG-CUTTER GUIDE AND HOLDER.**

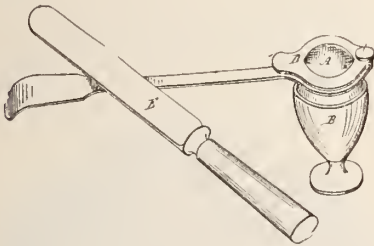

HIRAM B. EVEREST, Riverside, Cal.—Filed Aug 26, 1895. Serial No. 560,484. (No model.)

**560,415. DAMPING DEVICE FOR MUSIC BOXES.** HENRY LANFELDER, Jersey City, N. J.—Filed Jan. 26, 1895. Renewed Nov. 13, 1895. Serial No. 568,871. (No model.)

**560,461. WATCHMAKER'S ROLLER RE-**



MOVER. KENDIG H. BARE, Lancaster, Pa.—Filed Jan. 24, 1896. Serial No. 576,647. (No model.)

**560,489. BELT AND SKIRT ATTACHMENT.**

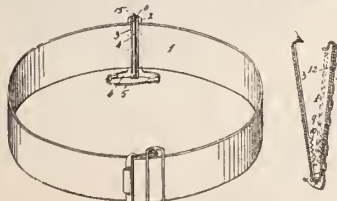

MAX FREUND, New York, N. Y.—Filed Dec. 6, 1895. Serial No. 571,278. (No model.)

As an improved article of manufacture, the belt-slide herein described and shown, consisting of a rigid base-plate 2 provided with corrugations 9 on its inner side and having at one end a catch 7, and a secondary plate 3 hinged at one end to the base-plate and formed integral with the continuous, longitudinal strengthening rib 14 at opposite sides of which are arranged two sets of corrugations 10 to co-operate with the corrugations of the base-plate, said secondary plate having at one end a knob or finger-piece 15 to engage and disengage the catch of the base plate.

**DESIGN 25,499. BADGE.** JOHN D. ADAMS, New



York, N. Y.—Filed Feb. 18, 1895. Serial No. 579,799. Term of patent 14 years.

**DESIGN 25,500. BADGE.** HARVEY M. THUR

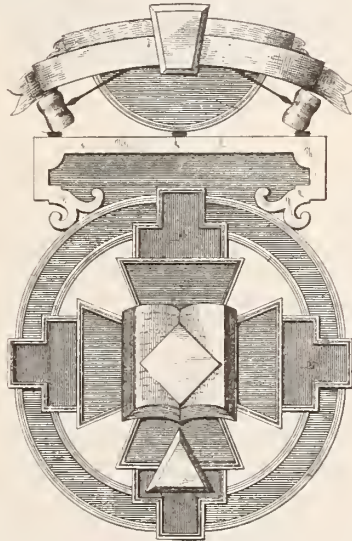

Boston, Mass.—Filed Jan. 23, 1896. Serial No. 576,600. Term of patent 14 years.

**DESIGN 25,501. WATCH CHAIN.** FRANK W.



WOOD, Indianapolis, Ind.—Filed Mar. 18, 1896. Serial No. 583,816. Term of patent 3½ years.

**DESIGN 25,502. SPOON.** IRA B. SMITH, Bristol, Conn. assignor to the Bristol Brass and Clock



Company, same place.—Filed April 13, 1896. Serial No. 587,416. Term of patent 7 years.

**DESIGN 25,503. HANDLE FOR SPOONS, etc.** WILLIAM C. CODMAN, Providence, R. I., assignor to the Gorham Manufacturing Company, same place.—Filed April 1, 1896. Serial No. 585,826. Term of patent 7 years.



to the Gorham Manufacturing Company, same place.—Filed April 1, 1896. Serial No. 585,826. Term of patent 7 years.

**DESIGN 25,504. HANDLE FOR SPOONS, etc.** WILLIAM C. CODMAN, Providence, R. I., assignor to the Gorham Manufacturing Company, same place.



—Filed April 15, 1896. Serial No. 58,827. Term of patent 7 years.

**DESIGN 25,505. SPOON-HANDLE.** EUSTACE CRESS and CHARLES S. COURT, Providence, R. I., assignors to the Watson & Newell Company, Incorporated, Attleborough, Mass.—Filed Mar. 24, 1896. Serial No. 584,695. Term of patent 7 years.



porated, Attleborough, Mass.—Filed Mar. 24, 1896. Serial No. 584,695. Term of patent 7 years.

**DESIGN 25,512. GLASS DISH.** WILLIAM C.

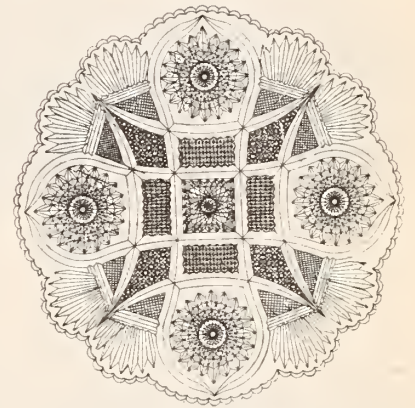

ANDERSON, Toledo, Ohio.—Filed March 19 1896. Serial No. 583,983. Term of patent 7 years.

**TRADEMARK 28,258. OPERA AND MARINE GLASSES.** SIESSFELD, LOESCH & Co., New York N. Y.—Filed April 20, 1896.



*Essential feature.*—The word "MAXIM." Used since February 1, 1896.

**TRADEMARK 28,259. WATCHCASES.** THEOPHILUS ZURBRUGG, Riverside, N. J.—Filed April 22, 1896.



*Essential feature.*—The representation of an arm and hand, the latter clutching or holding a hammer or mallet. Used since 1889.

**TRADEMARK 28,260. WRITING AND NOTE-PAPER AND PAPER USED FOR OTHER AND SIMILAR PURPOSES.** WHITING PAPER COMPANY, Holyoke, Mass., and New York, N. Y.—Filed April 18, 1896.



*Essential feature.*—The words "STATE BOND." Used since 1890.

The "Safety Case" FOR Riding Specs.

SOMETHING NEW . . . .

THIS INGENUOUSLY MADE CASE FILLS A LONG FELT WANT. IT IS STRONG, COMPACT, DURABLE AND CONVENIENT.

Ask Your Jobber for Them.

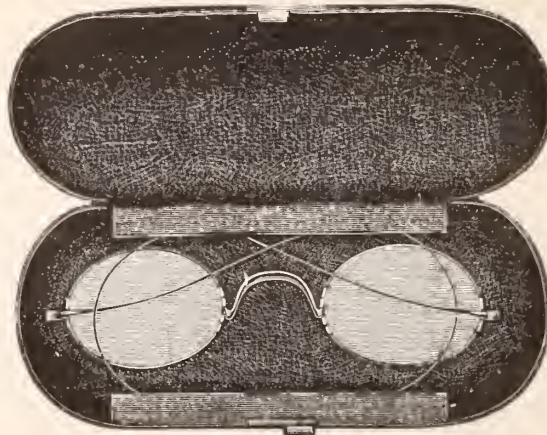

(PATENT APPLIED FOR.)

OUR REGULAR "SAFETY CASE," OF SIMILAR PATTERN, BUT SMALLER, IS THE BEST CASE EVER MADE FOR FRAMELESS, OFFSET EYEGLASSES.

For Sale by all Jobbers

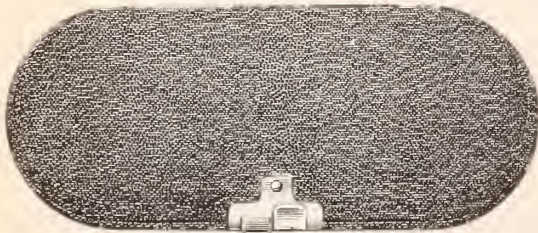

SUSSELD, LORSCH & CO.,  
13 Maiden Lane, N. Y.

**THE SPENCER OPTICAL INSTITUTE**  
THE RECOGNIZED OPTICAL SCHOOL FOR BUSINESSMEN

OUR COURSE PRACTICAL COMPREHENSIVE NONCLASSICAL IN THEORETICAL AND APPLIED OPTICS

OUR STUDENTS ARE THE SUCCESSFUL OPTICIANS

SEND FOR APPLICATION BLANK & PROSPECTUS. CLASSES CONVE NE 1<sup>ST</sup> TUES. EACH MONTH  
SPENCER OPTICAL MANUFACTURING CO. 15 MAIDEN LANE . N. Y.

S. M. LEWIS & CO.

SILVER GOODS A SPECIALTY.

Have Removed  
To the  
LORSCH BUILDING,

37 and 39 MAIDEN LANE, NEW YORK.



A 1  
MUSLIN BUFFS.

Sample sent prepaid on request.  
BE SURE to give size of buff and center hole.

WILLIAMSVILLE MFG. CO.,

18 South Water St., PROVIDENCE, R. I.  
MILLS: WILLIAMSVILLE, KILLINGLY, CONN.

FOR RELIABLE OPTICAL WORK  
SEND TO  
JOS. FRIEDLANDER & BRO.,  
OPTICAL LENS GRINDERS,  
9 MAIDEN LANE, - - NEW YORK.  
SEND FOR DESCRIPTIVE CIRCULAR OF OUR FRAME AND LENS CABINET.



REGINA  
MUSIC BOXES  
LINCOLN BLDG., 14th  
St. & Union Sq. W., N. Y.  
A. WOLFF,  
General Agent.

O. NEWMAN,  
Gold and Silver Electro-Plater.  
Etruscan Coloring a Specialty.  
WATCH CASE POLISHING.  
75 Nassau St., Room 8 Rear Building, New York.

H. M. RICH & CO.,  
Jewelry - Auctioneers,  
21 School Street,  
BOSTON, MASS.

DR. KNOWLES'  
PRIVATE COURSE  
IN OPTICS.  
Lectures with Diploma \$25.00  
Those who desire to study with the Doc-  
tor will send in their application.  
Students received at any time.  
CORRESPONDENCE COURSE PERFECTED.  
The Key to the Study of Refraction.  
50c. per copy,  
For Sale by  
R. H. KNOWLES, M. D.,  
189 Broadway, NEW YORK  
Care of JEWELERS' CIRCULAR.

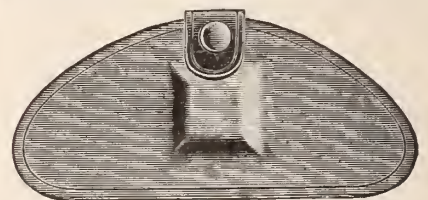

EXTRA THIN.



IN TWO SIZES.

KOENEN'S NEW SHELL CASE  
FOR OFFSET EYEGLASSES.  
THE LATEST AND BEST. THIN AND STRONG.  
Manufactured and Patented by  
A. KOENEN & BRO., 81 Nassau St., N. Y.  
SOLD BY: JOBBING TRADE.

# OPTICAL DEPARTMENT.

## Ocular Refraction.

AS RELATES TO THE CORRECTION OF VISUAL DEFECTS \*

BY R. H. KNOWLES, M. D.

**NOTE.**—The purpose of this series of articles is to give to the student without his having had any previous technical education, a clear and practical course of instruction in optics with its application to the fitting of glasses. The Correspondence Column is open to all readers of THE JEWELERS' CIRCULAR. All questions asked will be fully answered.

XXXIII.

(Commenced Feb. 27, 1895.)

### CHAPTER VII.

**M**USCULAR Asthenopia is that variety of weak sight due to some form of Myopia, either simple or Axial Myopia, Simple Myopic-Astigmatism, Compound Myopic-Astigmatism, or Myo-hyperopic-Astigmatism. In simple or axial myopia where the antero-posterior diameter is too long, the rays of light focus in front of the retina. The radiate fibres of the muscle of accommodation, or in other words the dilator iris, through the sympathetic nerves, render the crystalline lens as flat as possible, thus enabling the rays of light to focus farther back than they otherwise would. The motor-oculi in this instance is in a passive state, allowing the eye-ball to rotate outwardly and an insufficiency of the internal rectus becomes established; thus a tendency of divergence is in the horizontal plane in axial myopia.

In simple myopic astigmatism the superior rectus of one eye and the inferior rectus of its mate become relaxed, and the divergence is in the vertical plane or very nearly so.

In compound myopic astigmatism the internal, the superior and the inferior recti are involved and the divergence is mid-way between the horizontal and vertical planes or at an angle of about 45°, if the myopia and the myopic astigmatism are of the same amount; the greater the amount of myopia the greater will be the tending toward the horizontal plane; and the greater the amount of myopic astigmatism the greater the tending will be away from the horizontal plane.

In myo-hyperopic astigmatism the internal rectus together with the obliques are involved.

After testing the vision by means of both the subjective and objective methods, the muscles controlling the movements of the eyes should undergo an examination with and without the correction; and it will be found in nearly every instance that an insufficiency discovered without the correction will be relieved by means of the lenses alone which correct the error; thus demonstrating that the errors of refraction are in accommodation and muscular asthenopia the cause of the muscular trouble. The rule therefore is to always give the correction, as it can be demonstrated that asthenopia is to vision as four is to one, A. : V. :: 4 : 1. This of course, applies

to those conditions where the nervous system is not involved, which introduces necessarily other problems and different results to be worked out, such as the decentration of lenses or the addition of prisms. Orthoptic exercises and the operation of tenotomy not only for the cosmetic effort, but for a restoration of the eye-ball in equilibrium, which we believe should be the aim of the surgeon in operations upon eyes when the vision can be improved by giving the correction are necessary.

## OPTICAL CORRESPONDENCE.

Will you kindly advise me relative to purchasing a retinoscope, and will you inform me at the same time what concavity the lens should be as I have discovered there are a variety of scopes? Should the electric light demand a ground globe or will the ordinary one do?

V. H.

**ANSWER:**—The Galizowski Retinoscope is the one preferred before others; and if the



MUSCULAR ASTHENOPIA.  
2 Dioptres Myopia. 8° Exophoria.

mirror is a concave one, its surface should be one diopter concave. The gas Argand lamp with adjustable rack should be employed, but when this is impracticable and the electric light is the only one to be had, use the ground glass globes in preference to any others, as the ground glass globe can be employed to both advantages, especially in ophthalmoscopy.

Would you be kind enough and answer the following query:

A patient. A gentleman 53 years of age.

R. E. V.  $\frac{20}{100}$  :  $\frac{20}{20}$  w + 3. D<sup>s</sup>

L. E. V.  $\frac{20}{100}$  :  $\frac{20}{70}$  w - 5. D<sup>s</sup>

For reading I gave him:

R O. D. + 5 D<sup>s</sup>

O. S. - 3. L<sup>s</sup>

Will you give me your opinion as to whether this

is a case of anisometropia, and if the prescription given him for reading is correct?

**ANSWER:**—The above instance has the appearance of a case of anisometropia, as well as having the suggestions of second sight, although the age is in favor of its being the former. By watching the patient, and if the apparent myopia is progressive, and if his history is a good one up until now, it may be a very good indication of being a case of second sight in the left eye.

## Can See the X Rays.

**A** GIRL who can see the Roentgen rays has been found by Dr. Brandes, of Halle, who discovered her. Starting from the fact that the rays do not penetrate lenses, he hunted for some one the lens of whose eyes had been removed, an operation performed not rarely for extreme short-sightedness or for cataract. The girl, who had had the lens of her left eye removed, was able to see the light with it, though her right eye, which retained its lens, could see nothing. Dr. Brandes asserts that the rays affect the retina of the eye, and if anyone's head is enclosed in an opaque vessel near the source of the rays the light can be seen even with closed eyes.—New York Sun.

Fox & Stendicke, 61 Fulton St., New York, are turning out a very fine instrument in their new Javal-Schiötz ophthalmometer. The use of this instrument in quickly determining the amount, kind and axis of astigmatism, together with its effect upon the patient, has made it very popular with opticians and others who give especial attention to fitting glasses according to the most improved methods. The instrument is sold at a moderate price. Full instructions accompany the instrument, showing how to work it. The new folding ophthalmometer for use by opticians who have two or more offices is a great improvement. The instrument is easily taken apart, and fits into a dress suit case, measuring 27 x 15 x 6½ inches. A complete price list is published by Fox & Stendicke and mailed to any one who writes for it.

**W**  
**A**  
**T**  
**C**  
**H**

**GOLD FILLED.**

*Fahys* | 4K

**MONARCH**

**C**  
**A**  
**S**  
**E**  
**S**

**QUICK SELLERS.....**  
**IN STERLING SILVER**  
**ARE MADE BY**

**CODDING BROS. & HEILBORN,**  
North Attleboro, Mass.

**FERD. FUCHS & BROS.**  
**SILVERSMITHS.**  
MAKERS OF STERLING SILVERWARE,  
808-810 Greenwich St., - New York.

## News Gleanings.

John W. Clark, Denver, Col., has sold out.

M. K. Laudenslager has moved to Souderton, Pa.

John James, Paris, Ill., has sold out to Albert Mosel.

D. H. McNaughton, Lockhart, Tex., has given a trust deed.

Henry Hodges, of Paola, Kan., has given a realty mortgage for \$972.

Louis Berchard, Oswego, N. Y., has given a realty mortgage for \$8,500.

The Ed. R. Gifford Jewelry Co. have moved from Edina to Hannibal, Mo.

Gale Douglas has gone out of the jewelry business in Perry, Oklahoma.

Herman Spahr, Orangeburg, S. C., has released a realty mortgage of \$1,400.

O. F. Dingelhof & Co. have succeeded M. J. Dingelhof, Wilmington, N. C.

Judgment for \$343, has been entered against Otto G. Berner, Le Mars, Ia.

Judgment has been entered against J. C. Wilcox, Pleasant Hill, Mo., for \$168.

H. M. Avery, South Haven, Mich., has sold out to Wm. Tall, of Schoolcraft, Mich.

R. S. McCune has purchased the jewelry store of John Woollett, New London, Mo.

Jeweler Reichert, 306 Lackawanna Ave., Scranton, Pa., is going out of business.

J. D. McAulis, Beaver, Pa., will erect a new block, the store of which he will occupy.

A. Barrelet, the pioneer jeweler of Paxton, Ill., has decided to locate in Denver, Col.

It is reported that a jewelry factory will be located in Oxford, Pa., during the year.

C. P. Christiansen has removed his jewelry business from Nephi, Utah, to Salina, Utah.

H. C. Eversole, optician, Seattle, Wash., has had judgment entered against him for \$433.

F. M. Hawkins has given a bill of sale of his jewelry store in Minden, Neb., for \$800.

Isaac Sulzbacker, Florence, S. C., of the firm of Sulzbacker & Son, has given a realty mortgage for \$700.

William Phillips, Stockton, Ill., who formerly had a jewelry store in Warren, Ill., died a few days ago.

J. L. Miskiman has sold his interest in the jewelry and drug business of J. L. Miskiman & Co., Belt, Mont.

J. Jaskulek, of the Northwestern Watch & Jewelry Co., Portland, Ore., has given a chattel mortgage for \$4,352.

Matthew Johnston has purchased the jewelry store belonging to the estate of J. E. Southworth, Santa Clara, Cal.

W. A. Fisher, who operates a general store, drug and jewelry store in Dawn, Mo., has been sued on a note for \$500.

M. S. Darling, Springfield, Mo., has traded his stock of jewelry, and is now operating a general store in Northview, Mo.

Mr. Juvet, Glens Falls, N. Y., is closing

out his stock of jewelry, clocks, etc., and in his new store will devote his time mainly to his optical business.

The store of Harry B. Helms, Steubenville, O., was a few days ago closed by the sheriff on an execution in favor of his father, Alexander M. Helms, for \$7,200.

Last Wednesday morning J. Warren Davis, Portsmouth, N. H., made a voluntary assignment. His liabilities are upwards of \$6,000 and his assets are estimated at \$1,500.

F. M. Yerrick, a prominent jeweler of Jackson, Mich., for many years, has left for Martinsburg, W. Va., where he will locate. Previous to his departure he was banqueted by the veteran Jackson Guard and presented with a bicycle.

The case of Dosh vs. Diebin and Patterson, assignee of the old Keystone Standard Watch Co., Lancaster, Pa., was argued in the Supreme Court at Philadelphia, Pa., last week, the decision of the lower court being reversed.

The jewelry store of M. C. Mertz, Hudson, O., has been closed on an execution issued by Justice Rogers in favor of Spier & Forsheim, New York, for \$215.42. The stock is already mortgaged several times, and there are various other claims.

J. D. Sallade, jeweler, Norristown, Pa., has made 38 handsome badges for the graduating class of the Norristown High School. The background of the badge resembles a six cornered star. The breast part is enameled in blue and white, the class colors, with N. H. S. thereon in letters of gold.

The jewelry and gents' furnishing store of Isaac Goldstein, South Fork, Pa., which was reported robbed of \$300 in money and a gold watch some time a fortnight ago, was subsequently closed by the sheriff, executions aggregating \$17,000 having been issued against him. His branch store at Barnesboro was also closed.

Geo. W. Ludwig, Chambersburgh, Pa., has just had manufactured a handsome souvenir spoon. The bowl represents the diamond on the memorable morning when Gen. Lee and his command passed through there on the eve of the battle of Gettysburgh. The reproduction of the diamond is perfect and old residents recall it just as it appears in the spoon.

Jeweler Blocher, Chambersburgh, Pa., has introduced a selling novelty. He has had manufactured transparent glass paper-weights which bear excellent photographs of Chambersburgh's interesting points: Wilson college, the court house and fountain, the memorial tablet, Central church, etc. Beside these weights he has also a line of Gettysburgh scenes in a like form.

F. Johnson and Wm. Ellis, two alleged burglars were arrested a few days ago at Dean Lake, Mo., while attempting to steal a ride on the blind baggage. Ellis attempted to get away and was shot in the leg. They had burglarized the store of J. H. Moonan, of Miami, the Wednesday morning previous of several watches, gold rings, chains, charms etc. They were traced by the jewelry they had traded and sold.

## New Jewelry Businesses.

G. C. Lang, Barre, Vt.

W. L. Spear, McMechen, W. Va.

Harold Ormsby, Farmington, Me.

Mr. Harrison, East Chatham, N. Y.

G. W. Gardner, E. Main St., Salem, O.

A. B. Wall, 46 Main St. and 6 N. 3d St., Lafayette, Ind.

C. E. Ritchie, formerly with the J. C. Herkner Jewelry Co., Grand Rapids, Mich., has opened a jewelry and repair shop for himself at the corner of Burton Ave. and S. Division St.

The formal opening of the new store at 71 Church St., Burlington, Vt., of Chas. Wyman & Son, began May 15th and continued through next day. The store is one of the most richly furnished in the city. The ceiling is handsomely paneled and delicately tinted, while the show cases are of solid mahogany with plate glass fronts, making a very rich and substantial appearance.

## Connecticut.

The Paris Optical Co., New London, have announced the opening of an optical parlor in that city, at 108 State St.

A. L. Sercomb, Chicago, and H. H. Peck, Waterbury, called at the office of the Meriden Britannia Co., May 18th.

S. Kronholtz, the Stamford jeweler and optician, has recently fitted up a room in the rear of his store as an optical parlor.

W. P. Morgan, of San Francisco, manager of Meriden Britannia Co.'s office there, arrived in Meriden, May 18th, for a few days on business.

Thomas Fromberg, watch and clock maker, for the past two years with Charles Teske, has located at 436 Main St., Hartford, where he will attend to repairing.

H. B. Hoyt and Frank Lauder, appraisers of the estate of jeweler Richard Noack, South Norwalk, met at the store last Monday night with attorney G. H. Vosburgh, Jr., who is trustee, and prepared an inventory for the Probate Court.

In connection with Fritz Werder, Ernst Schall, jeweler, Hartford, has opened in his store in the Corning building, corner of Main and Asylum sts., an ice cream and confectionery store. Mr. Schall will not go out of the jewelry business but will continue in that line in the store on Asylum St., just back of the ice cream department.

Judge Cable, in the City Court, New Haven, put his foot down on a custom which has been in practice in the city for a long time. It is the repaying of pawnbrokers money for stolen articles recovered by the police and returned to the owners. The Judge said: "I am tired of this custom of repaying pawnbrokers money which they have advanced on stolen goods. It has been going on long enough and it is time it is stopped. I don't wish to encourage crime in this way, and I shall instruct officers hereafter in cases where small amounts are received for articles by pawnbrokers to prosecute the pawnbrokers for theft."



**Q**RE always of **Standard Quality**, of **Newest Styles** and **Best Finish**.

They will always sell when anything will, and cost no more than those of doubtful reputation.

Don't wait for our travelers, but send direct to



**Oldest Ring Makers in America.**

**M. B. BRYANT & CO.,** 10 Maiden Lane, N. Y.

Made by Merritt & Co. Springfield, Mass.

**COMFORT AND SECURITY ARE COMBINED IN MERRITT'S PATENT EYE GLASS HOLDERS.**

GOODS ON APPROVAL. CORRESPONDENCE SOLICITED.

**CROUCH & FITZGERALD.**



**Jewelry Trunks and Cases,**

161 Broadway, Bet. Cortlandt and Liberty Sts., 688 B'way, 701 6th Ave., NEW YORK

**NYE'S SUPERFINE OILS.**

Special grades for

**CHRONOMETERS, WATCHES, CLOCKS, JEWELERS' LATHES, ETC., ETC.**



**NYE'S OILS** acknowledged **SUPERIOR TO ALL OTHERS.**

**WM. F. NYE,** Manufacturer, New Bedford, Mass.



IT IS .... **A** **DEAD SURE THING**



...THAT...

**"WAITE, THRESHER'S GOODS SELL."**

WAITE, THRESHER COMPANY, MANUFACTURING JEWELERS, PROVIDENCE, R. I. N. Y. OFFICE, 178 BROADWAY.

# A JEWELER'S NECESSITY



— IS THE —

## “TRADE-MARKS OF THE JEWELRY AND KINDRED TRADES.”

Copyright, 1896, by The Jewe ers' Circular Pub. Co., 189 Broadway, New York.

For seven months THE JEWELERS' CIRCULAR has had under way a work that will comprise the trade-marks of every branch of the Jewelry, Watch, Clock, Silverware, Silver Plated Ware, Optical Goods, Precious Stone, Art Pottery, Bric-à-brac, Cut Glass and cognate lines of the Jewelry Industry.



The work is now nearing completion. We consider it will be the most valuable book that has ever been issued to the Jewelry trade.

It is a work which the retailer and wholesaler will immediately appreciate.

It will be a book of constant reference, and will be consulted more perhaps than any other book issued to the trade.

It will be a book of daily use.

It will be sold at a figure that will guarantee its rapid distribution.

In addition to illustrations of the various trade-marks and the names and the addresses of the firms to whom they belong, and the class of goods to which they appertain, the work will contain other interesting and valuable information bearing upon the subject of trade-marks.



Those firms who have as yet not sent electrotype, print or drawing of their trade-mark or trade-marks are requested to do so at the earliest possible moment.

Members of the Trade, Manufacturers, Wholesalers and Retailers should at once place their orders for

### “TRADE-MARKS OF THE JEWELRY AND KINDRED TRADES.”

\$1 per copy. Bound in Cloth. Payable now or upon delivery of Book. Detach order below and forward to the Jewelers' Circular Publishing Co., 189 Broadway, New York.



#### ADVANCE ORDER BLANK.

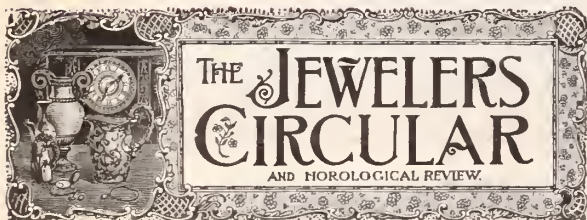

189 Broadway, New York.

1896.

Please file this order for \_\_\_\_\_ copy of

“Trade-Marks of the Jewelry and Kindred Trades”

for which I agree to pay \$1.00 per copy, postage prepaid, upon delivery of book.

Name.....

Street..... City..... State.....

## Workshop Notes.

**To Bend a Glass Tube.**—Fill the tube with finely sifted sand, close both ends, and heat it over the flame of a Bunsen burner. It may in this manner be bent readily without losing its roundness at the elbow.

**Frosting Polished Silver.**—Cyanide of potassium one ounce, dissolved in one-half pint water. Do not hold the silver in your hand, but use boxwood plyers, and apply the mixture to the surface with a brush.

**German Silver.**—An excellent German silver is prepared by smelting in a crucible 55 parts copper, 23 nickel, 17 zinc, 3 iron and 5 tin. This composition is in every respect equal to silver in appearance, fully as hard, and not vitreous.

**Soldering Britannia.**—For soldering Britannia, use the usual chloride of zinc soldering fluid, with a little sal-ammonia in it. An easy flowing solder can be made of tin, one part; bismuth, one-half part; lead, one part; carefully melted together at low heat.

**Vienna Lime.**—Vienna lime and alcohol give a beautiful polish to iron or steel. Select the soft pieces of lime, such as can easily be crushed by the thumb and finger, as they are the most free from gritty particles. Apply with a cork, piece of soft pine wood, leather or chamois.

**Care of Oil-stone.**—Keep an oil-stone covered when not in use. Clean it often with benzine, turpentine, or soap and water. Invariably use a good quality of oil—fine sperm oil is the best. If this oil is not liquid enough, add a little clock oil. Do not put too much oil on the stone, as the addition does not make the latter cut faster.

**Jewelers' Armenian Cement.**—Isinglass soaked in water and dissolved in spirits, 2 ounces (thick); dissolve in this 10 grains of very pale gum ammonia (in tears), by rubbing them together; then add 6 large tears of gum mastic, dissolved in the least possible quantity of rectified spirits. When carefully prepared, this cement resists moisture and dries colorless. Keep in a closely stopped vial.

**Face of a Graver.**—The face of a graver should be quite flat, and the edge obtained by rubbing the face only, and not by getting up the edge from the back; the back square being drawn over the stone to take off the burr, or feather-edge. A fast cutting Turkey stone would leave too coarse an edge on a graver for making small pivots; therefore a good Arkansas stone is preferable for keeping a good edge on a tool.

**Graver Blade.**—A graver having its cutting edges at right angles one with the other (as they must be if the graver is square) will make too wide and shallow a stroke. It will be found that from the edge of the graver on one side to the corresponding edge on the other side, crosswise as it is fitted into the handle, measures one-third more than it does across either of the flat sides of its belly. For kinds of work the tool to be used should be certain diamond in shape endwise, and the distance from edge to edge, crosswise of the blade,

should be equal to a width of a side of its belly.

**Diamond Turning Tools.**—It is sometimes desirable to reduce the dimensions of a hardened steel article that has received a lathe finish without first drawing the temper, as this necessitates a re-hardening and re-tempering. The usual method of lathe reducing of hardened steel articles by corundum wheel grinding is necessarily confined to straights or tapers, no offsets, collets or shoulders being amenable to this style of work. A model maker and bright mechanic has succeeded in utilizing the black diamonds or bort, as a turning tool for hardened steel. He places a crystal in the end of a piece of iron or brass for flat turning, and one on the side of the end or on a corner of the end, for side or shoulder turning. He has succeeded in doing some good work with these crude-looking tools. The chips taken from the hardened steel are literally chips, not turnings, and are very minute. But viewed under the microscope they are seen to be cut from the hardest steel, and not merely disengaged crystals. One of the specimens of work with these bort tools is a well finished V thread, about 32 to the inch. Two different crystals of the diamond were employed to cut and true the thread.

**Exhausted Gold Baths.**—Economy and the superlative degree of care and watchfulness are the fundamental conditions in a manufacturing jewelers' establishment; no material that ever entered and was used in the shop should be thrown away; more or less gold will cling to it, and it has a certain value. Let the jeweler ever remember the Scotch proverb, "Many a mickle make a muckle." A jeweler of Pforzheim, Germany, prompted by curiosity, recently had the soil around his shop analyzed, and it was found that quite a fair quantity of gold dust was carried out of the shop, clinging to the soles of his workmen's shoes. To this category also belong exhausted gold baths, which must be collected and sold to an assayer. It is not an easy job to reduce the gold from a cyanide bath; a chloride of gold solution is more easily handled, as the metal can be precipitated with a solution of sulphate of iron. It is not worth while bothering with a few quarts of cyanide of gold baths yourself; collect quite a lot and then use the following method. Add to the gold bath, either in open air or a well drawing chimney, sulphuric acid until the reaction has become of an acid nature—that is, until the fluid colors blue litmus paper red. Take care when doing this not to breathe the air, as the hydro-cyanic acid escapes in the form of a gas. Then pour the fluid in a porcelain dish and let it evaporate, until it begins to dry. Now add slowly and carefully about one-fourth of the volume of the fluid of concentrated acid, and then heat.

## Aluminium Alloys.

ALL the aluminium alloys are distinguished for their very peculiar colors, which have never yet been noticed in other

metal alloys. Especially interesting are the alloys of aluminium and gold, which give every promise that they will be of importance for purposes of decoration. Aluminium with an alloy of 6 per cent. gold retains its pure color; with 10 per cent., this passes into a brown violet and the metal possesses great capacity for polishing and hardness. A 15 per cent. is violet white, soft, and of fine grain. Equal parts of gold and aluminium give a fairly porous metal of an admirable violet blue shade, while, if the percentage of gold is still increased, the color passes more into pure violet. With 90 per cent. gold, the color is matt violet, and with 94, a handsome rose. Gold alloys with a trifling percentage of aluminium turn, when through heating, into an extremely brilliant violet. Alloys of 50 gold, 45 copper, 5 aluminium are very strong and look like 14 karat gold.

Aluminium with from 4 to 8 per cent. silver is very hard, pure silver white, and takes a high polish. This alloy is already used for models and articles of ornament. Nickel, copper, and aluminium form extremely hard, strong, and fine grained alloys. A red gold alloy of most excellent characteristics is obtained from nickel 24, copper 66, and aluminium 10. A gold-brown alloy is produced by copper 55, nickel 33, aluminium 12.

## To File an Arbor or Drift Square by Hand.

THE most expeditious mode of making a square, as, for example, that of a barrel arbor, is by the use of a proper tool, but in its absence the square must be made by hand.

Soften the jaws of a hand-vise and make four flat faces on them, forming an exact square, either by filing or by attaching pieces by rivets. Having clamped the steel on which a square is to be formed in the vise, hold this in one hand and rest it in a recess in a wood block; with the other hand hold the file, determining its position by laying it on the upper face of the square before applying it to the arbor.

After giving one or two strokes, test the truth of the face formed by again laying the file on the upper face of the vise. Then turn the vise through a quarter of a circle and proceed in the same manner, for the other two faces. Before finishing the square and while there still remains a slight excess of metal on each face, ascertain by examining the end and measuring the length of the faces, whether the square is accurately formed. Set it up in the finishing turns and draw a flat file in the direction of the axis along each face. If the square is to be polished after hardening, proceed in the same manner, using an iron polisher in place of the file, to which longitudinal, transverse and circular motions may be given.

After hardening, the square must be tempered to some shade between pale yellow and a deep blue, according to the purpose for which it is intended.

# THE BRAND,

The unquestionable brand,  
The brand of all brands,  
The first of all brands,  
The tried and true brand.

It's  
The



"ANCHOR" BRAND

## SILVER PLATED WARE.

It counts for everything that's good and true and of artistic design in **Silver Plated Ware.**

No one else makes it. No one makes its equal.

FACTORIES:

Hartford, Conn.  
Norwich, Conn.  
Taunton, Mass.

**WM. ROGERS  
MAN'F'G CO.,**

Office and Salesrooms: Hartford, Conn.

There is no longer any uncertainty about belt pins this season. They will sell, are selling. We make a very large and complete line, at lower prices than ever before. Use the pin stamped "Pat. April 3rd, 1888" if you want the best.

All silver not less than 925-1000 fine.



B. A. BALLOU & CO.,  
61 Peck Street,  
Providence, R. I.

ESTABLISHED HALF A CENTURY.

# MARVIN'S FIRE & BURGLAR SAFES

HAVE MANY PATENTED IMPROVEMENTS  
NOT FOUND IN OTHER MAKES

THAT WILL WELL REPAY AN INVESTIGATION

BY THOSE WHO DESIRE TO SECURE  
**THE BEST SAFE**  
MARVIN SAFE CO.

12 PARK PLACE, NEW YORK.

## MELISHEK & PETTER.

128 Maiden Lane, New York.

MANUFACTURERS OF

WALL AND COUNTER CASES,

FOR JEWELRY, SILVER-  
WARE, ETC.

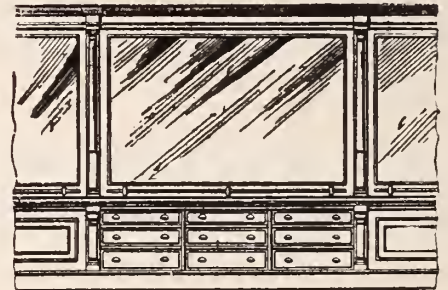

We make to order only, and guarantee our work to be Dust Proof and First-Class in all its details, and to have all the Latest Improvements as regards Shelf Arrangements, Electric Lights, Etc. We will cheerfully furnish Estimates and Sketches for any store free of charge.

CALL AND SEE US.

## AIKIN, LAMBERT & CO.,

MANUFACTURERS OF

FINE GOLD PENS, HOLDERS, PENCILS,  
TOOTH PICKS, and NOVELTIES.

PAUL E. WIRT FOUNTAIN PENS, at new and lower prices . . .  
MERCANTILE FOUNTAIN PENS, guaranteed to give satisfaction.

Catalogues with terms and discounts furnished to the trade.

BRANCH, 103 STATE STREET, - - - CHICAGO.

## AIKIN-LAMBERT JEWELRY CO.,

IMPORTERS OF

# DIAMONDS.

JOBBER IN

WATCHES, JEWELRY, CHAINS  
NOVELTIES, ETC.

LATEST DESIGNS.

LOWEST PRICES

19 MAIDEN LANE, NEW YORK.



### The Rambler's Notes.

WHAT THE RAMBLER SAW AND HEARD AMONG THE DEALERS IN ART POTTERY CUT GLASS BRONZES ETC.

**LARGE AND ELABORATE PEDESTALS.** VERY large and elaborate pedestals are among the pieces just added to the art product department of Geo. Borgfeldt & Co., 18, 20 and 22 Washington Place, New York. The vases and tops of these pedestals are composed of slabs of green and brown imported onyx, while the pillars are of Royal Bonn showing various decorations in flower, figure panels or brown Delft styles. At the top and bottom of the pillars are deep collars in rich gilt.

**CARRARA MARBLES.** IN the marble room of Ferd. Bing & Co.'s building, 10 Washington Place, New York, is a line of Carrara marble figures and busts which will interest all jewelers. These pieces, though finely executed, are no more expensive than many products in Castellina marble of the same sizes. In connection with this line is shown a fine assortment of domestic and Mexican onyx pedestals.

**THE BEAUTY OF BALERIC FINISH.** "BALERIC" is the name which the Bradley & Hubbard Mfg. Co. have given to the most beautiful finish yet produced on the art metal goods they make for the jewelry trade. In color, it is a shaded red-brown, blending into green and orange, similar to the beautiful Rookwood pottery, and its hardness, luster and finish give it the appearance of fine porcelain. The vases and other articles with Baleric finish are also handsomely ornamented with gold, and are now exhibited for the first time at the company's salesrooms, 26 and 28 Park Place, New York.

**AMERICAN ART CHINA.** MANY very artistic productions are to be seen in the china of the Art China Decorating Co., controlled by Levy, Dreyfus & Co., 11 Maiden Lane, New York. The new and handsome designs in plaques, the chrysanthemum treatment on plates, plaques and trays, and the Coalport studded effects on cups and saucers, which

this china now shows, are worthy of high praise, both from an artistic and a decorative standpoint. These pieces are all of the finest French china, and are decorated in this country by American and foreign artists in the



NEW BUILDING OF GLAENZER FRÈRES & RHEINBOLDT.

company's employ. Levy, Dreyfus & Co. are now making a feature of a line of combs, brushes, mirrors and toilet articles with decorated china backs mounted in silver.

THE RAMBLER.

The most popular way of setting the opal is in finger rings and necklaces.

### Glaenger Frères & Rheinboldt's New Home.

THE recent removal of Glaenger Frères & Rheinboldt from 80 Chambers St. to their new building, 26 and 28 Washington Place, New York, marks another step in the northward procession of the importers of fine bronzes, clocks, pottery, etc., from the bounds of the "crockery district" of New York. The new home of Glaenger Frères & Rheinboldt, of which an illustration here appears, is but a few feet west from Washington Square, and is opposite the side of the new University building. It is a white stone and terra cotta brick building, seven stories high, and is fitted with an electric elevator and all other modern conveniences.

On the ground floor in the rear are the offices and counting house of the firm, while in the front is a fine display of choice pieces in bronzes, pedestals, marble statuary and hall clocks and a fine collection of framed miniatures. The second floor is the clock department in which is displayed the largest collection of mantel chimes of all sizes, gilt and crystal regulators, French porcelain, porcelain and bronze, gilt, bronze, faience and traveling clocks, that the firm have ever carried. The third floor is divided into three departments. The front room, decorated in dove gray, contains various lines of bronzes, in busts, groups, statues and small ornamental pieces. Of the two rear rooms, the west room, decorated in red brown, contains the firm's Royal Vienna, Royal Dresden and Royal Berlin lines, while the east room, in bright red, is devoted entirely to Sèvres ware. Here is displayed a collection of extra large Sèvres vases worthy the consideration of connoisseurs and dealers.

The optical department occupies the fourth floor, while the fifth floor contains the lamp department, Teplitz and Bonn pottery, Metlach beer mugs and German china lines. The sixth floor is given over to brushes and other sundries imported by this house and the seventh and top floor contains their Delft pottery, German goods, glassware and miscellaneous lines. The building also has two floors below the street level. The basement is used by Glaenger Frères & Rheinboldt as the stock room and the sub-cellar as the receiving and shipping departments.

## Queries by Circular Readers.

**NOTE.**—Questions under this department will be answered as promptly as possible. Some queries require careful investigation before a satisfactory answer can be given; hence such answers are often seemingly delayed. THE CIRCULAR desires every jeweler to take advantage of this department.

NEW YORK, MAY 7.

Editor of THE JEWELERS' CIRCULAR:

Is it possible to find the number in which you gave the process of soldering aluminum. It will be a great pleasure for

Yours respectfully  
L. BONET.

ANSWER:—In THE CIRCULAR of Jan. 15, 1896, page 43, appeared a lengthy article on aluminum solders.

AKRON, OHIO, May 6, 1896.

Editor of THE JEWELERS' CIRCULAR:

I wish to make a request of you as to the receipt for imitation of inlaying of silver, which is found on page 154 of a book which you published some time ago called "Workshop Notes for Jewelers and Watchmakers." I have melted the pure tin and mixed in the quick-silver as directed and ground it up and it is small as fine sand. Now I wish to know what kind of size to mix it with. I have tried the regular painters' size and it don't seem to work. By answering and trying to inform me as to how it is prepared, you will greatly oblige.

CHAS. B. ZINK,  
With the Foltz Co.

ANSWER:—Ordinary painters' size would act too slowly; the size best suited is perhaps the Japan gold size.

TORONTO, CAN., May 14th, 1896.

Editor of THE JEWELERS' CIRCULAR:

Would you kindly inform me through your columns if I can obtain a reliable book treating on the art of enameling, giving practical illustrations of how to obtain satisfactory results, and which is the best manu-

factured enamel to use; trusting to receive the desired information through your valuable paper

I remain,

L. H. LUKE.

With Ambrose Kent & Sons

ANSWER:—As far as our knowledge extends, the best publication of any matter regarding enameling, is contained in our own book, "Workshop Notes for Jewelers and Watchmakers," pages 129 to 136. This matter was printed in THE CIRCULAR about seven years ago; we consider it to be as practical as any published. The best manufactured enamel, we think, is that sold by A. Sartorius & Co., 28 Barclay St., New York.

## A Hint to Restauranters.

FOUR local newspaper men were comparing notes recently on the restaurants they have known.

"Saw a novel device in Chicago not long ago," said one. "Friend took me through a big cheap jewelry factory. Rubies by the quart, diamonds by the pint. Gold rings till you couldn't rest. 'What's here?' said I, as I pointed to a glass jar filled with creamy pellets.

"'Pearls,' said the foreman. 'Ten cents a gross. We sell 'em to the cheap restaurant men.'

"'What for?' says I.

"'They drop one in each plate of oyster stew,' says the foreman.

"'What for?' says I again.

"'Customer scrapes round in stew. Doesn't see any oysters. Grand kick coming. Finds pearl. Grins ecstatically. Sneaks pearl

into vest pocket. Eats stew. Doesn't complain. Pays check and goes away smiling. See?'—*Cleveland Plain Dealer.*

## Vegetable Diamonds.

THE alkaloid of *Calycanthus glaucus*, discovered and first extracted by Dr. Eccles, may be obtained in crystals which from their high refractive power sparkle very much like diamonds. Some were shown at a recent meeting of the New York section of the American Chemical Society. This alkaloid has the highest refractive power of any known organic substance. A nitroso-compound of calycanthine is thalleioanthine; this forms dark colored salts that in dilute solution are a brilliant green. No therapeutic application of the alkaloids has yet been announced.—*Popular Science News.*

**Relation of Train to Balance.**—The relation of escapement to balance is a subject which is attracting the attention of thinking watchmakers just at the present time, especially as it relates to isochronal adjustment. That the relations of train and escapement to balance and balance spring, are not important factors in isochronal adjustments, but few who have had any experience will contend. No one except a novice would hold that a balance spring perfectly isochronal in a chronometer escapement would be so in a lever using precisely the same balance. It would not even give a close rate.

# BAWO & DOTTER BULLETIN

## HALL CLOCKS==CHIMING CLOCKS.

New Cases now ready—made of oak or mahogany—carved inlaid or trimmed with bronze ornaments—in a great variety of new and beautiful designs. All our cases are made in this country and the material, workmanship and finish is unequalled. **MOVEMENTS**—Elliot's automatic chimes, on musical bars or gongs—Elliot's gong chiming movements with 5 or 9 gongs, and with and without the 8 cup bells, etc.

English recoil and dead beat, hour and half strike, weight movements with beautiful dials.

B. & D.'s new weight movement.

A LARGER OR BETTER STOCK CANNOT BE FOUND.

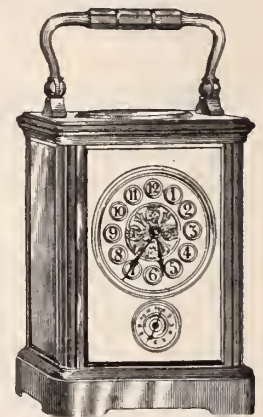

**TRAVELING CLOCKS.**  
Large stock on hand.  
Timers—Strikers—Repeaters—  
¼ Strikers.

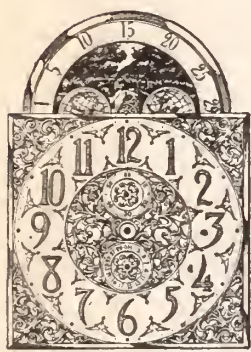

461 ENGRAVED ORNAMENTS RAISED FIGURES—DIAL 47234

**BAWO & DOTTER,** Manufacturers, Importers and  
Commission Merchants,

26, 28, 30 and 32 BARCLAY ST., NEW YORK.

# THE SWAN FOUNTAIN PEN

Reputation World Wide.  
Made upon Distinct Principles.  
Is a Compressed Air Pump.  
Simply Wet the Insides to Provoke  
an Energy.

W. W. Stewart, Inventor and Patentee.

A variety of Styles and Prices

- 3 Sizes Safety Swans.
- 3 Sizes Self-filling Swans.
- 3 Sizes Adjustable Swans.

## MABIE, TODD & BARD,

NEW YORK AND LONDON.

ESTABLISHED 1870.



TRADE MARK.

## FINE CASES,

For Jewelry, Silverware, Etc.

HARDWOOD CHESTS,  
TRAYS AND SAMPLE CASES.

Samuel C. Jackson's Son.

180 Broadway,  
New York.

## The Bonner Combination

RING, STUD and SCARF PIN.  
A Long Screw and a Round Bezel.

Send for Selection Packag.

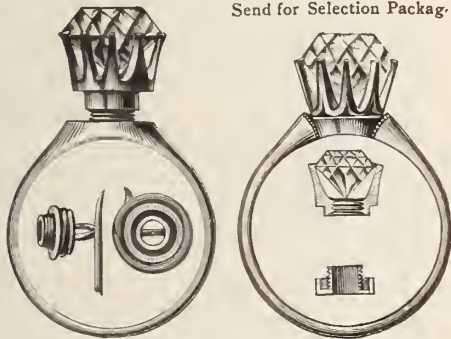

BONNER, RICH & CO.,

41 & 43 Maiden Lane, NEW YORK,  
604 Champlain Building, CHICAGO.

## JACOT & SON,

Importers and Manufacturers of

## Musical Boxes,

39 Union Square, New York,

# AJAX INSULATORS.

PATENTED OCTOBER 28, 1889.

THEY are Cheap; THEY Reduce Wear and Tear of the Case;  
THEY Protect from all Ordinary Magnetic Influences.

Perfect in  
Action.

Convenient  
in Use.



Educate  
Your Customers  
by Talking  
up  
Ajax Watch  
Insulators.

MADE IN ALL SIZES, OPEN FACE AND HUNTING.  
FOR SALE BY JOBBERS.

MANUFACTURED BY

## The Newark Watch Case Material Co.

19 WARD STREET, NEWARK, N. J.

# SURPASSED ALL RECORDS!

AT THE OBSERVATORY OF GENEVA, OUT OF TEN  
MOVEMENTS (*CONSECUTIVE NUMBERS.*) THE

## CHAS. MEYLEN WATCHES

OBTAINED

2 First PRIZES,

4 MEDALS

AND

4 DIPLOMAS.



## MATHEY BROS., MATHEZ & CO.,

— SOLE AGENTS, —

21 AND 23 MAIDEN LANE, NEW YORK.

PLAIN AND COMPLICATED WATCHES.

## ENAMELED AND DIAMOND WATCHES.

**CYCLING PROGRESS  
EXEMPLIFIED.**

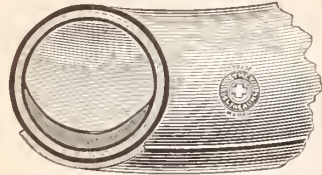

**THE WONDERFUL  
SELF-HEALING TIRES**

are single tube, finest rubber, finest wove Sea Island cotton fibre, re-enforced inside and outside on tread, and no better tire can possibly be made. They are fully guaranteed against all climatic changes, are the most resilient ever made, and when punctured instantly heal the wound of their own volition.

THEY WEIGH NO MORE THAN OTHERS,  
COST NO MORE,  
AND ARE WORTH TEN TIMES MORE.

—SEND FOR THE BOOKLET—  
**WM. H. CAHN, GENERAL MANAGER,**  
48 and 50 Maiden Lane, New York.

**BY EVERY TEST THEY ARE THE BEST.  
THE UNIVERSAL FAVORITES.**



**SUPERB  
Olympic  
BICYCLES**

For sale by more than 2,000  
Jewelers, and constructed to meet  
the demand for finest quality.  
For Adults and Juveniles.

**SEND FOR EXQUISITE  
CATALOGUE.**

Top Grade "Olympics" have SELF-  
HEALING TIRES.

Olympic Cycle Mfg. Co.,  
N. Y. Office: 35 LIBERTY STREET.

General Jobbing Ag'ts, S. F. MYERS & CO.,  
WHOLESALE JEWELERS, Myers' Building, New York

**CHAS. JACQUES  
CLOCK  
CO.,**

22 Cortlandt St.  
NEW YORK.



Hall Clocks,  
Traveling Clocks,  
Gilt Clocks,  
Porcelain Clocks,  
Delft Clocks,  
Mantel Chime  
Clocks,  
Bronzes,  
Sevres Vases.

- - EMMONS - -  
ASSOCIATED LAW OFFICES.

PORTLAND, SEATTLE, TACOMA,  
Oregon. Wash. Wash.  
Foreign Business a Specialty.

**BAWO & DOTTER,**  
26-32 BARCLAY ST.,  
NEW YORK.



P. O. Box 1872.

NO LARGER STOCK  
OF  
**HALL  
CLOCKS**

IS SHOWN IN  
THIS CITY.

Large Stock  
OF  
MOVEMENTS.

NEW DESIGNS  
IN CASES.

**DUBOIS WATCH CASE CO.**  
TRADE  MARK  
REGISTERED.  
FINE HAND MADE  
**SOLID GOLD CASES.**  
A PRIDE TO THE MAKER,  
DEALER & WEARER.

**L. LELONG & BRO.,**  
GOLD AND SILVER

Refiners, Assayers and Sweep Smelters,  
SOUTHWEST CORNER HALSEY AND MARSHALL STREETS,  
**NEWARK, N. J.**

SWEEPINGS A SPECIALTY.

**STERLING**

SHEET AND WIRE SUPPLIED ALL SIZES.

**J. SCHAWEL & CO.,**  
Gold, Silver and Platinum Refiners.  
29 John Street, N. Y.

ALBERT LORSCH.

ALFRED KROWER

**ALBERT LORSCH & Co.,**

LORSCH BUILDING

37 & 39 Maiden Lane,  
NEW YORK.



167 Weybosset St.,  
PROVIDENCE, R. I.

IMPORTERS OF DIAMONDS, RUBIES, EMERALDS, ETC.,  
AND IMITATION STONES THEREOF.

•• Fine Miniatures on Ivory and Enameled Paintings. ••

**WE WILL CONTINUE TO MANUFACTURE**

Our Fine Mountings at our present location, No. 11 Maiden Lane, New York, till May 1st, 1897 when the buildings are to be removed.

**HENRYE. OPPENHEIMER & CO.** OFFICE: 14 MAIDEN LANE, NEW YORK.

DIAMONDS and Cutters. L. & M. KAHN & CO., 172 Broadway, DIAMONDS





# THE JEWELERS' CIRCULAR

AND HOROLOGICAL REVIEW.

Copyright by THE JEWELERS' CIRCULAR PUB. CO.

189 Broadway, New York.

Entered at the Post Office in N. Y. as second-class matter.

VOL. XXXII.

NEW YORK, WEDNESDAY, JUNE 3, 1896.

No. 18.

## CHARACTERISTICS OF ARABIAN ART METAL WORK.

In no department of Arab art is the influence of the style which the Persian Sasanians inherited and developed from Assyrian models more distinctly visible than in metal work, where we find the Persian ornamentation by means of human and animal figures prevail-

caliphs at Cario he saw the throne of El-Mustansir, which was made of pure gold and silver, chased with beautiful inscriptions and hunting scenes; and the inventory of the same caliph's possessions recorded by the historian El-Makrizy describes an extraordinary collection of magnificent objects in the precious metals and stones. All these have disappeared, however, and it is only from the close of the thirteenth century, that we are able to study Egyptian metalwork from objects still in existence; but thenceforward its development may be continuously observed up to the beginning of the sixteenth century. The connection with Mesopotamia is easily traced. Many objects bear the name of the artist and of the city of Mosul, and we see the characteristic style of Mesopotamian ornament in the human figures, hunting scenes, etc., chased in silver, inlaid on bronze. The contemporaneous metal work of Egypt itself reveals the same technical method of inlay and chasing, but the ornament is modified in accordance with the prevailing ideas of all Saracenic decoration in that country. There is more floral and geometrical ornament, of the same style that we see in wood carvings and stone and stucco work of the period, and less of the representation of figures and animals, which is typical of Mosul.

Among the choicest examples in the Arab Museum, London, is the kursy or table of the Mamluk Sultan En-Nasir Mohammed, illustrated on this page, No. 2, on which we see representations of ducks (in allusion, no doubt, to the name of En-Nasir's father Kalaun, which means "duck" in old Turkish), but these figures are quite subordinate to the floral and geometrical decoration. This table is unquestionably a product of the Saracenic art of Egypt, and El-Makrizy tells us that there was a "Market of Inlayers" (Suk-el-Keftiyin) at Cario, and that richly dressed objects, such as a dikka or settle, inlaid with silver and gold, after the manner of our table, formed a prominent feature in wedding gifts. One of them belonging to

Sitt-el-Amam ("Lady of the Turbans"), a merchant's daughter, was so richly decorated that her betrothed gave her 100,000 dirhems (francs) merely to repair it. This passion for costly inlay had already vanished in El-Makrizy's day (he died in 1441), and only a small



INLAID SILVER AND BRASS KURS—No. 1.  
XIVTH CENTURY.

ing in spite of the objections of strict Muslims. The traveler Nasir-i-Khusrau, who visited many Mohammadan countries in 1035-1042, besides noticing the gold and silver work at Tyre and Jerusalem, dwells especially on the triumphs of the goldsmith's art which he saw in Egypt in 1040. In the palace of the Fatimid

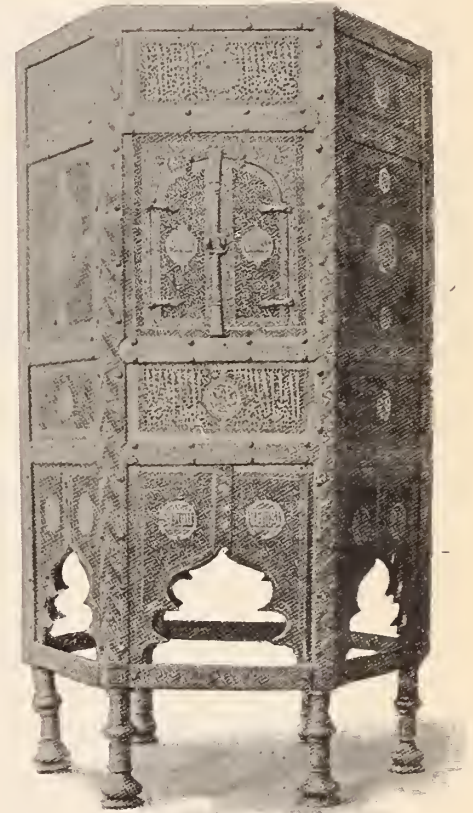

INLAID SILVER AND BRASS KURS—No. 2.  
XIVTH CENTURY.

number of inlayers then plied their trade. The value which the owners placed upon such possessions may be inferred from the fact that they often had their names engraved upon them, and one sometimes finds a series of successive proprietors' names on a single dish or bowl

# OUR DRESDENE BELTS ARE THE LATEST FAD.

**BELTS IN  
LEATHER AND SILK  
WEBBING.**

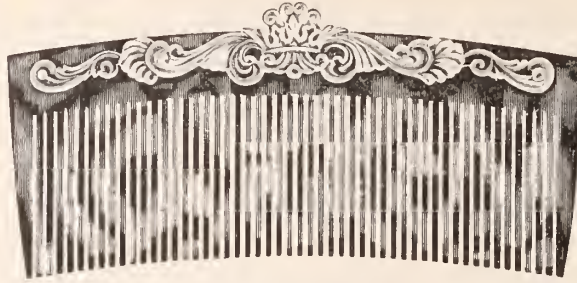

**SIDE COMBS  
MOUNTED IN  
STERLING SILVER  
WITH STONES.**

**NEW YORK OFFICE:  
21 & 23 MAIDEN LANE.**

**FACTORY:  
PROVIDENCE, R. I.**

**BOSTON OFFICE:  
403 WASHINGTON ST.**

## OUR GOODS

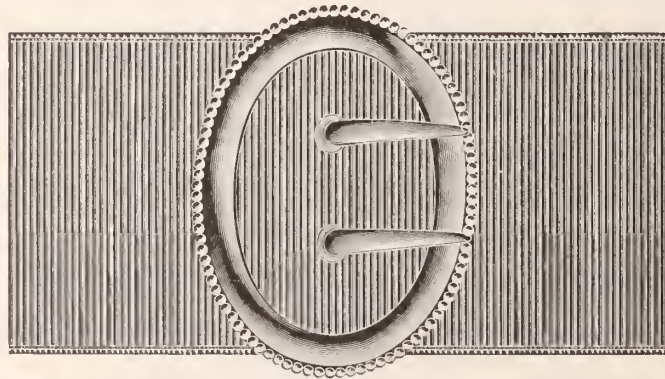

## THE BEST.



# KENT & STANLEY CO., LTD.

**THE SPENCER OPTICAL INSTITUTE**  
 THE RECOGNIZED OPTICAL SCHOOL FOR BUSINESS MEN

OUR COURSE PRACTICAL COMPREHENSIVE NONCLASSICAL IN THEORETICAL AND APPLIED OPTICS

OUR STUDENTS ARE THE SUCCESSFUL OPTICANS

SEND FOR APPLICATION BLANK & PROSPECTUS. CLASSES CONVEENE 1ST TUES. EACH MONTH  
 SPENCER OPTICAL MANUFACTURING CO. 15 MAIDEN LANE. N. Y.

### BAND RING MOUNTING



DESIGN  
PATENTED  
Sept. 24,  
1895.



**CHARLES KNAPP,**  
MANUFACTURING JEWELER,  
41 & 43 Maiden Lane, New York.  
SPECIALTY: SUPERIOR LADIES' and CHILDREN'S RINGS

## “Apparel oft proclaims the man.”

**PARSONS & GREENE CO.**  
P & G CO.

TRADE MARK

HOLYOKE, MASS., U. S. A.

**CHOICE PAPERS**

So with our fine note papers, envelopes and papeteries—all our bands, boxes and labels are neat, tasty and artistic and perfectly in keeping with and a credit to the high grade goods with which they are used. Our fashionable stationery is put up in a manner that appeals to people of refined tastes, and it is a line particularly adapted for jewelers. We **do not** sell to dry goods or department stores. Write for samples.

**PARSONS & GREENE CO.,**  
MANUFACTURING STATIONERS,  
HOLYOKE, MASS.

# NEW ORNAMENTS

... IN ...

## STERLING SILVER.



Many Designs in

Galleries, Belt Buckles,  
Belt Slides **AND** Belt Fastenings,

ALWAYS SOMETHING NEW.

### THOMAS W. LIND,

Manufacturer of

JEWELERS' FINDINGS.

67 Friendship Street,

PROVIDENCE, R. I.

# Buy "The Best"

THE  
"Dueber  
Special"  
BICYCLE.

MAYSVILLE, KY., April 24, 1896.

Dueber Watch Case Mfg. Co., Canton, O.

Dear Sirs: The wheel came all right, and in fact exceeds my expectations. I have ridden the different high grade wheels for twenty years, and find this the easiest running wheel I have ever been on. Yours,

JOHN BALLENGER.

CHICAGO, ILL., April 23, 1896.

Dueber Watch Works, Canton, O.

Gentlemen: After a careful and critical examination of the "Dueber Special" Bicycle, I have no hesitancy in recommending it as a first-class wheel in every respect and I consider it the best wheel I have ever seen. The extreme care bestowed upon the fitting and finish of all parts, will alone recommend it to the watch making fraternity, who as a rule, are critical in these respects. The "Dueber Special" ranks with, if it does not surpass the highest grade wheels on the market. I see no reason why it should not have an enormous sale.

Very respectfully,

GEO. K. HAZLITT.



# Standard Sterling Silver Goods.

Belts,

LEATHER, GILT,  
SILVER AND  
SILK WEBBING.

Waist Sets,

Sleeve Links,  
Hat Pins,

IN

Sterling Silver

AND

Rolled Gold Plate.

600 Useful Articles

IN

## Sterling Silver.



# Foster & Bailey,

Providence, R. I.

NEW YORK,  
SAMPLES ONLY.

CHICAGO,  
SAMPLES ONLY.

The metals employed were copper and its various alloys, which can only be distinguished by chemical tests. The objects include large caldrons, coffers, tables, bowls, censers, candleabra, lamps, bosses and plating on doors, etc. The last are most readily dated and ascribed to Cairo workers; the oldest are the fold-

leaves of the medresa of Barkuk, with bronze foliage coated with silver, and those of El-Ghury, show that the art was still pursued with undiminished skill under the Circassian Mamluks. The various lamps and lanterns or chandeliers in the Museum of the XIVth c. and XVth c., are constructed in tiers to carry numerous

engraved with the name of Allah or the arms of the founder, for heraldic devices were much in vogue in the fifteenth century. Nothing in the way of metal work, however, surpasses for taste or skill the kursis already mentioned, or the little book-box with its delicate designs and enchanting kufic border, which still show traces of the gold inlay which was reserved for the finest class of work. After the sixteenth century bronze fell out of vogue; it was no longer used for the doors of mosques or other public buildings, and although gratings were still made of it, they were no longer skilfully fitted together, but were cast in a single piece. About the second half of the eighteenth century Western influences begin to intrude in the designs.

Besides bronze, the Arab smith worked in iron. Nasir-i-Khusrau mentions the iron-plated doors of the Harem at Jerusalem, and also the massive iron doors of El-Mahdiva in Tunis. In Egypt, iron was not in great demand for artistic purposes, but one may cite the forged iron gratings in certain mosques, especially in that of En-Nasir in the Citadel, which attracted the attention of El-Makrizy. Iron nails arranged in effective patterns were sometimes used to decorate the doors of mosques and some of the old gates of the city quarters, which were formerly closed at night.

[This article is adopted from the Catalogue of the National Museum of Arab Art, London, England.]

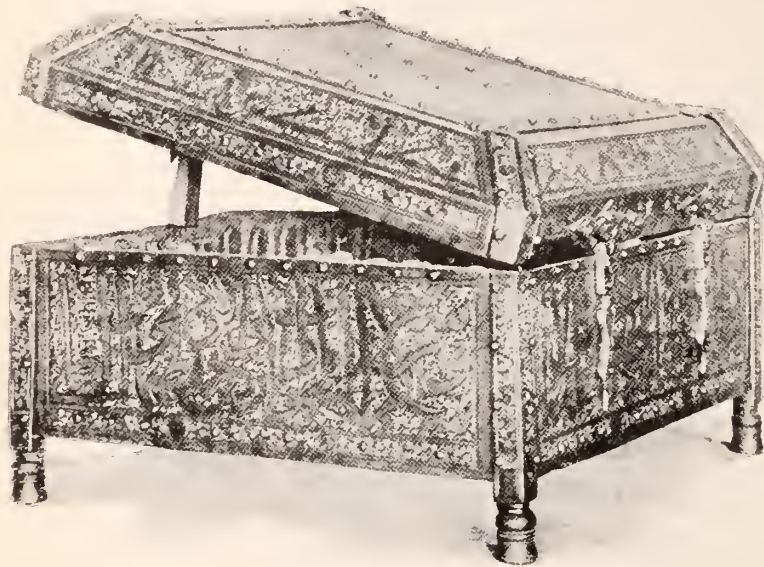

KORAN CASE PLATED WITH BRASS, INLAID WITH SILVER AND GOLD.

ing doors from the mosque of Es-Salih Talai'b. Ruzzik, built A. H. 555 (1160), are covered with starlike polygonal designs in cast bronze on a thin surface of brass. Here the castings are plain; but others are engraved with very graceful designs, as on the doors which came from the medresa of Tatar el-Higaziya, granddaughter of Kalaun, founded in 761 A. H. (1359.) To about the same time (1362) belongs the door of the tomb of Sultan Hasan, with its delicate inlay of gold and silver. The two

little oil lamps, which are prevented from dripping upon the worshippers by a tray which is hung beneath, and which also concealed the unattractive interior. The tray in question is partly in repoussé work, chased with decoration of the latest Mamluk style; for it comes from the mosque of El-Ghury, founded in 1503. The gratings, especially those which closed the windows of sebils (street drinking fountains), were also subjects for decoration, and their knobs were often

**Acid Proof Cement.**—A cement that resists acid is made by melting 1 part Indian rubber with 2 parts linseed oil; add sufficient white bolees for consistency. Neither muriatic nor nitric acid will attack it; it softens a little in heat, and its surface does not dry easily; this is corrected by adding one-half part litharge.

## AMERICAN WATCH CASE CO.,

11 JOHN STREET, NEW YORK.

Manufacturers of FINE SOLID GOLD CASES.

**A.W.C.CO**

Sold DIRECT to  
the RETAIL TRADE only.

## SLOAN & COMPANY,

SUCCEEDING

JOHN A. RILEY & SLOAN CO.,

MANUFACTURING JEWELERS,

23 MAIDEN LANE, N. Y.

HAYS BUILDING.

AUGUSTUS K. SLOAN, Pres.  
FRANK T. SLOAN, Vice-Pres.

BENNET OSBORN, JR., Treas.  
ALLAN A. McDONALD, Sec'y.



## The STATIONERS' ENGRAVING CO.,

98 TO 102 NASSAU STREET, NEW YORK.

MAKERS OF

WEDDING INVITATIONS, RECEPTION AND VISITING CARDS

of the Best Quality, which are offered to Jewelers of recognized standing only.

Trade Mark 'SILVER WHITE,' registered.

**O. NEWMAN,**  
Gold and Silver Electro-Plater.  
Etruscan Coloring a Specialty.  
WATCH CASE POLISHING.

75 Nassau St., Room 8 Rear Building, New York.

**H. M. RICH & CO.,**  
Jewelry - Auctioneers,  
21 School Street,  
BOSTON, MASS.

**DR. KNOWLES'**  
PRIVATE COURSE  
IN OPTICS.

Lectures with Diploma \$25.00

Those who desire to study with the Doctor will send in their application. Students received at any time.

CORRESPONDENCE COURSE PERFECTED.

*The Key to the Study of Refraction.*  
50c. per copy.

For Sale by

**R. H. KNOWLES, M. D.,**  
189 Broadway, NEW YORK.  
Care of JEWELERS' CIRCULAR.

# IMPORTANT.

## The United States Circuit Court of Appeals

has decided that the Colby patent for pendant setting Watch Cases is invalid, and from this decision there is no appeal.

We are, therefore, the only manufacturers and ours the only valid pendant set device used in the manufacture of pendant setting Watch Cases.

In answer to some inquiries made of us, we wish to say we do not manufacture a pendant setting Watch Case for the new model 16 size Elgin Watch movement.

**The Dueber Watch Case Mfg. Co.,**  
CANTON, OHIO.

---

# ROGERS, SMITH & Co

MADISON SQUARE,  
NEW YORK.

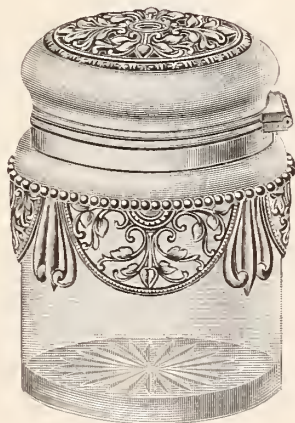

MERIDEN,  
CONN.

GOLD AND SILVER PLATE.

## Jewels in the Czar's Coronation.

IN the coronation of Nicholas III, Czar of Russia, last week, jewels and goldsmiths' work played no inconsiderable part. Before the procession started for the Cathedral of the Assumption, the Grand Almoner, bearing a large golden cross studded with jewels, assisted by two deacons carrying a golden bowl full of holy water, sprinkled the whole route which was to be followed by their Majesties from the Palace to the Cathedral. Richard Harding Davis, in his dispatches to the *New York Journal* wrote as follows:

"The Dowager Empress entered first, and forty priests, with long beards and long hair and vestments stiff with gold, received her, their miters, like great kettles, glittering with jewels. She wore a crown of diamonds and a

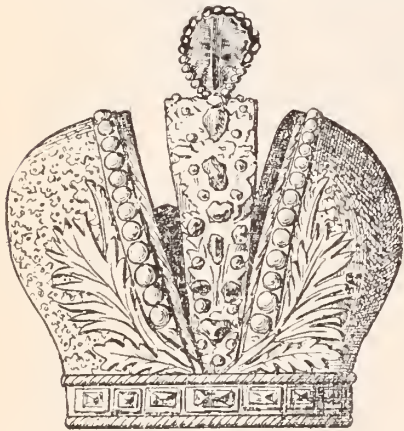

THE CZAR'S CROWN.

From the *New York Herald*.

dress of silver cloth, necklaces and belts of diamonds, and the collar of St. Andrew's in diamonds resting on her mantle. She seated herself on the throne to the left of the platform. The throne was of silver and studded with 880 diamonds. The foreign princes and princesses followed her, the former going to the right of the dais, the latter to the left. A herald in a suit of gold with a gold trumpet came next, followed by Ministers of the Court, bearing the insignia on cushions. Then came the royal robes of ermine carried by four of the grand dukes, who literally staggered

under their weight. During this procession the priests chanted a weird, eerie melody, without accompaniment. To its music came the Emperor and Empress. The young Empress was inexpressibly beautiful, showing that graceful contour of face which her photographs have made familiar. She wore a dress of white satin and silver. Around her neck was a single string of pearls. In the mass of tiaras and diamond ornaments all about her the contrast was striking. She seated herself on the throne of ivory-carved figures to the right of the Emperor, who sat on the large throne of silver, carved with turquoise. \* \* \*

"Two Grand Dukes, his uncle, Vladimir, and young brother, Alexander, took the collars of the different orders from the Emperor's neck and lifted the ermine mantle to his shoulders. It was fifteen feet in length, of gold cloth, covered with double eagles, embroidered with silk and precious stones, and with a cape of ermine. Over this was placed the diamond collar of St. Andrew."

Then the Czar received the crown from the Metropolitan and placed it on his own head and took the globe and scepter in either hand. In the head of the scepter is the Orloff diamond, for which the Russian Government paid the Orloff family \$1,000,000, and ennobled them.

In reference to some of the celebrities present, Mr. Davis wrote:

"There was the Marquis Yamagata, who had met the giant of Eastern diplomacy, Chang, as David met Goliath, and had overthrown him. There was the Crown Prince of Siam, and the French Ambassador, who had made him a dependent on that republic. There was the Queen of Gondah, wrapped in a green shawl, with her bare, brown arms hidden in bracelets, her bare feet in jeweled sandals, and next to her the civilized Queen of Greece in furs and diamonds."

Half of the extent of the cathedral is filled with tombs and altars hidden by a screen, which the same writer describes as follows: "The screen itself is of copper, covered with gold and precious stones, and those who like guide-book accuracy will be interested to know that the gold on the screen is pure gold and weighs 10,800 pounds. It is beaten and embossed into the figures of saints, the faces

being painted and the halos around the head of each being composed of pearls and diamonds."

## Jeweled Dresses Made for the Coronation.

PARIS, France, May 22.—Many gorgeous dresses introducing precious stones have been sent from Paris to be worn at the Czar's coronation fêtes at Moscow. A national dress made for a Russian princess is of cherry colored velvet opening over a front of pearl white satin, embroidered with silver wheatears, among which diamonds glitter here and there. The velvet train is bordered with a rather broad band of raised silver embroidery punctuated with brilliants, the design showing wheatears gracefully intermingled with Louis quatorze motifs. The princess wore the jeweled diadem called *Kaloshnik*.

Very handsome are the two court dresses and the three ball gowns made for the

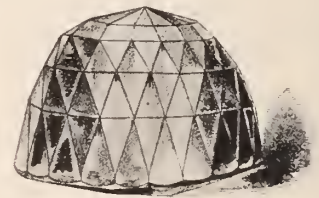

THE ORLOFF DIAMOND—FULL SIZE.

Countess de Montebello, wife of the French ambassador in Russia. One of the gowns is in pale rose satin, showing through a white net glittering with gold spangles. A broad band, embroidered with pearls and turquoises, runs across the bust; a similar band, gradually extending in width, descends from the bust to the feet; in front, one of the dresses is in sky-blue satin. The low-neck corsage is ornamented from the top to the point descending beneath the waist, with bow-knots in jeweled gold lace gradually diminishing in size. The court mantle made for the French ambassadress is in straw colored satin adorned with a magnificent border of raised embroidery exhibiting palms of green gold, with pearls. The mantle is attached on the shoulders, and over each sleeve of the dress worn underneath there is a kind of wing called *chéruse*, which is in dainty silver network punctuated with pearls. The most gorgeous of the court robes is in a pure empire style; it is in ripe corn colored satin embroidered in the same fashion as was the state mantle worn by Empress Josephine at the coronation of Napoleon I., the embroidery consisting of pear shaped pearls set into rosacea divided and wrapped up with a handsome foliage formed of moss green and bronzy gold silk.

JASEUR.

OPPENHEIMER BROS. & VEITH,  
CUTTERS OF DIAMONDS,  
DEALERS IN WATCHES,

65 NASSAU STREET (PRESCOTT BUILDING), NEW YORK.

WOOD & HUGHES,  
STERLING SILVERWARE MANUFACTURERS  
New York Agents for the Derby Silver Co.,  
FINE QUADRUPLE PLATED WARE,  
No. 16 JOHN STREET, - - - NEW YORK  
206 Kearney St., San Francisco, Cal.  
HASKELL & MUEGGE, Agents.

PLATE OF ORIGINAL DESIGNS, NO. 8--LINK BUTTONS, BRUSH BACK, ETC.



*Designed and drawn specially for The Jewelers' Circular*

BY A. BONNIOL & SON, DIE SINKERS, 119 ORANGE ST., PROVIDENCE, R. I.

## JEWELRY IN DEMAND IN VARIOUS PARTS OF THE COUNTRY.

Reports by "The Circular" Correspondents.

### SILVER GOODS, CUT GLASS, BICYCLE CHAINS IN CINCINNATI.

CINCINNATI, O., May 25.—The sales during the past week have been principally the necessities, waist sets and belts. The watch trade has revived somewhat; since the races opened at Oakley the demand for timers has set in. Mr. Galbreath, president of the Duhme Co., says the most notable sales have been in the silver line; cut glass has a fair showing. The June weddings have been an incentive to sales in these lines.

Mr. Hellebush says the bicycle chains have had a good run this week. Oskamp, Nolting & Co. have had a number of sales in flat ware sets. Loring Andrews & Co. advertised marquetry and mahogany, pottery and bronzes for festival buyers; these are the rare bits of bric-à-brac not found in many stores.

### SILVERWARE OF ALL KINDS, AND ENAMEL WATCHES IN LOUISVILLE, KY.

LOUISVILLE, Ky., May 25.—The Louisville jewelers have been selling silver punch and berry bowls, tea sets, combination sets, trunks of silver, a number of the small enamel watches with bow knots and fleur-de-lis, a good deal of Rookwood pottery, but most of all the blouse sets and belts. There have been some diamonds sold.

### LADIES' CYCLING WATCHES AND OPAL RINGS IN TORONTO.

TORONTO, Can., May 26.—The retail trade in this city is, on the whole, quiet. The principal feature is an active demand for silver blouse sets and silver trimmings for leather belts in great variety of assorted leathers. There is a noticeable increase in the sale of good watches, a specialty in the watch trade which is now a good deal called for being ladies' cycling watches. In ladies' rings some large lines have been put on the market, the opal being the favorite stone. Combinations of opal and diamond are popular at present.

Though the extraordinary development of the bicycling craze has had a depressing effect upon the watch trade generally, it has notably increased the demand for chronograph watches for timing purposes, in connection with bicycling. Last week negotiations were

completed for the purchase by the Goldsmiths' Stock Co., Toronto, of the entire stock of chronograph watches held by Schwob Bros., Montreal, agents for the Timing & Repeating Watch Co., Geneva, Switzerland, who are retiring from the Canadian trade. These watches, numbering several hundred, have been put on the market. Moses Schwob has returned to Switzerland, where he will take up his residence.

### SILVER NOVELTIES IN BIRMINGHAM, ALA.

BIRMINGHAM, Ala., May 26.—The jewelers of the city report the greater volume of their business is in silver novelties. Belts and blouse sets take the lead. Business generally with local jewelers is reported quiet.

### CUT GLASS, SILVER, AND JEWELRY FOR WEDDINGS IN DETROIT, MICH.

DETROIT, Mich., May 26.—Detroit retail jewelers, in regard to the present demand for goods, say that they are selling large quantities of medium-priced and cheap belts, in leather, and metallic tinsel with silver trimmings. There is also a heavy demand for shirt waist sets. The demand for watches is slightly below that of previous weeks; this is also true of high-priced jewelry and diamonds. However, there is an increasing interest in cut glassware, silverware, and jewelry for June weddings. Jobbers say that country dealers are also buying the belts, waist sets, and link buttons, besides other seasonable novelties.

### PRIZES AND SUMMER GOODS IN WORCESTER, MASS.

WORCESTER, Mass., May 26.—Since the opening of the sporting season the leading jewelers have received long orders for prizes. F. A. Knowlton furnished the trophy for the *Telegram* bicycle road race. H. Lucke received the order for the City Guards game Memorial Day, and F. A. Knowlton, H. Lucke and Geo. H. Corbett Co. have received orders for medals used for individual time prizes.

Aside from the prize feature of the jewelry trade there has been a good Spring trade in silver novelties, principally belts, buckles and the silver and gold novelties that go to make

up the Summer girl's up-to-date wardrobe. With the approach of June the wedding present trade becomes brisk and this affects all branches of the trade with slight partiality to the silver counter.

### LINK BUTTONS AND BLOUSE SETS IN BURLINGTON, IA.

BURLINGTON, Ia., May 24.—A general improvement in business was shown in April, and May started well. As usual in this section the planting of crops at this season keeps the country trade away and cuts off a portion of the retail trade. As the outlook for a fine crop is good, an increased business is looked for in the late Summer and Fall.

Link cuff buttons and sterling silver blouse sets have been the most extensively advertised articles during the past three weeks. The usual June weddings will make a demand for cut glass and silverware.

### DIAMONDS IN DEMAND IN PHILADELPHIA, PA.

PHILADELPHIA, Pa., May 26.—Many purchases are reported in the diamond business this week. Jewelers also state that there has been a steadily increasing demand for belts of various kinds and for blouse sets.

### FAIR SALES OF SILVERWARE IN DAVENPORT, IA.

DAVENPORT, Ia., May 25.—Davenport, Ia., jewelers report a run on blouse sets and belts, with fair sales of silverware, and watches and clocks moving rather slowly.

### STEADY DEMAND FOR NEW BELTS IN INDIANAPOLIS, IND.

INDIANAPOLIS, Ind., May 26.—While trade is quiet, the jewelers report a steady demand for the new styles in leather belts and shirt waist sets. As June approaches a nice trade in wedding presents is anticipated.

### WEDDING DIAMONDS AND WATCHES IN PITTSBURGH, PA.

PITTSBURGH, Pa., May 25.—Pittsburgh jewelers are doing a steady business in the sale of silver novelties and find that waist sets and belts have the call. Leather belts with silver buckles are much in demand. Wedding diamonds and many watches were sold during the past two weeks, and it is anticipated that June weddings will create a small boom in silver and bric-à-brac. The sale of belts and waist sets will continue well on to mid-Summer.

## VACHERON & CONSTANTIN, GENEVA, SWITZERLAND.



FINEST QUALITY OF WATCH MOVEMENTS, FITTING ALL SIZES OF AMERICAN CASES • INCLUDING

\* V. & C. \*

THE NEW FLAT 16 SIZE ELGIN CASES.

EDMOND E. ROBERT,

Agent for the United States and Canada.

REMOVED TO 3 MAIDEN LANE, NEW YORK.

## CROUCH & FITZGERALD.

Jewelry Trunks and Cases,

161

Broadway,

bet. Cortlandt and

Liberty Sts.,

688 B'way,

701 6th Ave.,

NEW YORK





**HIGH-PRICED GOODS IN GREAT DEMAND IN MONTREAL, CAN.**

MONTREAL, May 25.—The jewelry business in Montreal just now is brisk. There is a good demand for precious stones and more and a greater variety of them are being sold now than ever before. There is an unusually large demand for opals of which more are sold than any other kind of precious stone. Amethysts are also fashionable while as for pearls there never was such a demand for them as there is to-day. With regard to jewelry proper miniature brooches of the most expensive kind are in great demand.

There is a craze for miniature buttons, which, while it has spoilt the demand for low priced miniature brooches, has increased the demand for very fine ones. There is little demand for silver jewelry, but the demand for silver novelties is large. There are new styles in gentlemen's jewelry. The variety of cuff links to-day is very large, and they embrace all kinds of patterns. The demand for tie pins is small.

**Philadelphia Jewelers Will Close Early During the Summer.**

PHILADELPHIA, Pa., May 28.—The manufacturing and jobbing jewelers of Philadelphia have agreed to close their places of business on Saturdays at 1 o'clock and on week days at 5 o'clock P. M. from June 1 to September 15 inclusive. The following firms have agreed to this action :

Louis A. Scherr & Co., Simons, Bro. & Co., David F. Conover & Co., H. Muhr's Sons, Morris Vogel & Bro., Quaker City Watch Co., Pfaelzer Bros. & Co., S. Kind & Co., Jacob Bennett & Son, Henry Euler, M. Sickles & Sons, H. F. Seltzer & Co., Dilsheimer Bros., J. G. Rosengarten & Co., Joseph Deschamps, J. C. Buck & Co., A. R. Justice & Co., John Smedley, Isaac Bedichimer, Joseph Bechtel, Dennison Mfg. Co., D. Kolb's Sons, H. G. Gill, Alfred Humbert, James W. Barry, Garber & Chattin, William Morris & Co., J. A. Schwarz & Co., Hirst & Moreh, L. P. White, James Bingham, Joralemon & Diesinger, W. H. Stetser, F. W. Lewall, Bernard Levy, W. Faber & Sons, Peter L. Krider Co., E. J. Hertz, Hamilton & Diesinger, H. B. Sommers & Co.

Strikingly novel and beautiful are the new "Dresdene" belts which Kent & Stanley Co. Ltd., Providence, R. I., have just brought out. These belts are made with a backing of best silk webbing, faced with celluoid, which is decorated with fine ornamentations in the popular Dresden style. The effect is that produced by genuine Dresden china. The belts can be easily cleaned, and are very light though substantial. They are made with or without eyelets and are mounted with the regular styles of Kent & Stanley buckles.

**FERD. FUCHS & BROS.**  
**SILVERSMITHS.**  
MAKERS OF STERLING SILVERWARE,  
808-810 Greenwich St., - New York.



Made in  
Sterling Silver  
and  
Silver Plate.

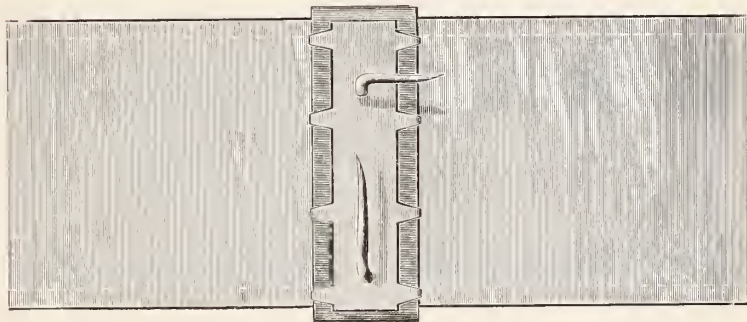

PATENTED.

With our "Never Sag" Belt Attachment, you can wear the popular narrow belts and feel content in the knowledge that your skirt cannot sag, even the fraction of an inch. Your shirt waist too, will always be in its proper position.

**NO BUTTONS TO SEW ON. WILL NOT TEAR THE FABRIC.**

Applied to any width of belt from one inch to two and a half inches.  
Apply our "Never Sag" attachment to your leather slides, it will more than double your sales.

SEND FOR SAMPLES AND PRICES.

**E. L. LOGEE & CO.,** Patentees, 183 EDDY STREET,  
PROVIDENCE, R. I.

**DORFLINGER'S**

**AMERICAN**

**CUT GLASS.**

915 BROADWAY  
36 MURRAY ST.  
NEW YORK.



**DIAMONDS.**  
**Wm. S. Hedges & Co.,**  
 IMPORTERS OF  
 Diamonds and Precious Stones.  
 DIAMOND JEWELRY.  
 170 Broadway, New York.  
 22 Holborn Viaduct, London.

**Alfred H. Smith & Co.,**

IMPORTERS

DIAMONDS

AND

PRECIOUS STONES,

182 BROADWAY, COR. JOHN STREET,  
 NEW YORK.

Venetian  
 Building, 34 & 36 Washington St  
 CHICAGO, ILL.

**Purchasers**

.. OF ..

**RARE GEMS,**

PRECIOUS STONES  
 AND ALL GOODS FOR  
 JEWELRY,

ADDRESS

**R. A. KIPLING, Paris,**  
**19 Rue Drouot, France.**

**L. BONET,**

ESTABLISHED 1866.

**PRECIOUS STONES,**  
 CAMEO PORTRAITS, WORKS OF ART,  
 927 BROADWAY NEW YORK.

DON'T FORGET THE JEWELERS' CIRCULAR PUBLISHING CO.'S BOOK LIST when in want of any technical book in the Jewelry or Kindred Trades.

**SCHULZ & RUDOLPH,**  
 IMPORTERS AND CUTTERS OF  
 AND  
**DIAMONDS OTHER PRECIOUS STONES,**

(Successors to JOHN E. HYDE'S SONS.)

Sole Agents for **The Celebrated Jules Jurgensen Watches.**

28 JOHN ST. and 65 NASSAU ST., NEW YORK.

**The Bowden Rings**

ARE COMPLETE IN VARIETY, CORRECT  
 IN QUALITY AND PERFECT IN FINISH.  
 WE MAKE EVERY VARIETY OF FINGER  
 RINGS.

**J. B. BOWDEN & Co.,**

3 MAIDEN LANE,

 **NEW YORK.**

BRANCH OFFICE:  
 206 KEARNY STREET  
 SAN FRANCISCO, CAL.

**Jeweler Rose's Wife's Illness Preyed Upon His Mind.**

AUBURN, N. Y., May 29.—A. H. Rose, a jeweler in State St., 40 years old, shot himself just above the heart at his home, 88 Wall St., about 5:30 o'clock, Monday morning. His wife has been sick nearly all Winter, and her sickness preyed upon his mind.

His son Edgar heard a pistol shot and found his father sitting up in the doorway leading from the kitchen to the dining-room. Edgar went for a physician while one of his older brothers summoned another. Neither doctor probed for the bullet, as they said it was not in a vital spot. Mr. Rose was taken to the City hospital. He will live.

**Mrs. Burgess Shot by a Tramp.**

NEW HAVEN, Conn., May 25.—Mrs. Burgess, wife of E. T. Burgess, president of the Burgess Cut Glass Mfg. Co., Middletown, was shot by a tramp this forenoon at her residence, at South Farms. The tramp had demanded food and money at the house which was refused. Soon after Mrs. Burgess went to her flower garden and on her return found the tramp robbing the house. On the bureau was a loaded revolver which the tramp had found in a bureau drawer. He grasped the weapon, seized Mrs. Burgess, forced her against the wall and fired. Mrs. Burgess's struggles probably saved her from receiving a fatal wound; as it was she was badly wounded in the wrist. Her screams alarmed the tramp who fled. A police posse is in pursuit of him.

**The Gate City Jewelry Co. Give a Deed of Trust.**

DENISON, Tex., May 28.—Major L. L. Maughs has taken charge of the stock of jewelry of the Gate City Jewelry Co. under a trust deed made by the company. Preferred creditors: Maughs & Peck; Head, Dillard & Muse, \$750; National Bank of Denison, \$1,500; Mrs. Kate H. Bostick, \$6,000; E. L. Green, \$1,500; total, \$9,750. The last three items are notes and have accrued interest, making preferred liabilities fully \$10,000. Assets not known.

Stone Bros., importers and manufacturers of jewelry, 535 Broadway, New York, have commenced the manufacture of sterling silver novelties in an extensive new factory at 138 and 140 W. 14th St. This new branch of their business will be conducted under the able direction of Frederick Schmidt, who was formerly with Tiffany & Co., and who for the past five years has acted as superintendent and designer for Geo. W. Shiebler & Co. A trademark has been adopted by Stone Bros. which consists of three letters "S" crossed by an arrow.

**THIS TRADE MARK . . .**



on cut glass is a guarantee of superior quality. Designs all new and original. Libby blanks used exclusively. Send for catalogue.

**STANDARD CUT GLASS CO.,**  
 545-547-549 W. 22d St., New York

## Early Summer Fashions in Jewelry and Silver.

### A LADY'S RAMBLES AMONG THE JEWELERS.

Pearls are in greater demand than ever and are largely used for necklaces.

\*

All kinds of fancy colored stones are worn, including carbuncles, peridots, amethysts, topazes, turquoises, and above all sapphires.

\*

Birthday watches claim attention. These have dials enameled with the flower of the month or set with the natal stone.

\*

The peculiar greens and blues that prevail in dress fabrics are shown in enamels on gold and silver.

\*

A favorite style of necklace consists of three rows of pearls, each with a separate diamond clasp, so that they can be worn singly, if so required.

The peculiar gilding on silver, known as rose gold, is employed now in the making of toilet articles, bonbon boxes and the like.

\*

Leather dressing bags, with silver mounted furnishings, show fresh improvement and useful additions that appeal to travelers.

\*

Flowers and scrolls represented in brilliants are arranged as a pendant, which is also adapted for wearing in the hair, or as a brooch.

\*

Opals remain fashionable and certainly lend themselves well to the lapidary's art.

\*

A dragon-fly of diamonds, with wings of opal, is a coveted object.

\*

Tortoise-shell spectacle cases are made with chased silver mounts.

\*

Fans are in order, and jewelers have made them more or less gorgeous with miniature medallions and gold and gems.

\*

Diamond aigrettes and hair ornaments of exquisite design are among the sparkling fascinations that rivet attention in jewelers' show cases.

\*

This season is noticeable for the unusual number of fine examples of enameled decoration. This artistic ornamentation pervades every department of the jewelers' and silversmiths' art.

\*

A compact cycling case for women is made in morocco or pigskin, and contains a purse, scent bottle, mirror and watch. The time-piece is inserted in the flap of the case in such a manner that the dial is seen from the outside.

\*

Dainty liqueur bottles are supplemented with silver mounted cut glass drinking cups for punch.

ELSIE BEE.

ESTABLISHED 1840.

## RANDEL, BAREMORE & BILLINGS.

IMPORTERS OF

# DIAMONDS,

AND OTHER PRECIOUS STONES.

**FINE PEARLS A SPECIALTY.**

MANUFACTURERS OF

# DIAMOND JEWELRY

A Large Stock of Fine Mounted Goods Constantly on Hand.  
Goods Sent on Approval and Insured in Transit.

Diamonds Cut, Recut and Repaired.

58 Nassau Street,  
29 Maiden Lane.  
NEW YORK.

1 Tulp Straat,  
AMSTERDAM.

1 St. Andrew's St.,  
Holborn Circus,  
LONDON E. C.

ESTABLISHED 1841.



## CARTER, HASTINGS & HOWE,

MANUFACTURERS OF

# GOLD JEWELRY,

15 MAIDEN LANE, NEW YORK.

A. CARTER,

C. E. HASTINGS,  
W. T. CARTER

G. R. HOWE  
W. T. COUGH

FACTORY, NEWARK, N. J.

JOHN P. CAMPBELL,

MANUFACTURER OF

## WATCH CASES.

ALL KINDS OF SPECIAL CASE WORK.  
REPAIRING A SPECIALTY.

59 Nassau St., Cor. Maiden Lane, New York.

Royal Arcanum and Maltique Ladies' Enamel Cases

HERMAN KOHLBUSCH, SR.

Established 1859  
Manufacturer of  
FINE BALANCES  
AND WEIGHTS for  
every purpose  
where accuracy is  
required. 59 Nassau  
Street, cor.  
Maiden Ln. N. Y.



Repairs (any make)  
promptly made.



## Herman Keck Convicted as a Diamond Smuggler.

PHILADELPHIA, Pa., May 30.—After an interesting three days' trial during which it was evident that somebody deliberately and persistently committed wilful perjury, a verdict of guilty has been reached, and Herman Keck stands convicted in the United States District Court of smuggling 563 diamonds valued at over \$7,000 into this country from Antwerp without the payment of duty and without entry on the customs records. A sealed verdict in the case was rendered before Judge Butler yesterday morning and the result did not appear to create much surprise, the general opinion seeming to be that weighty and convincing evidence had been presented by the Government's witnesses.

Counsel for the defendant made a motion for a new trial immediately after the jury had rendered the decision that pronounced Keck a diamond smuggler. The attorney said he would file his reasons with the court at an early date, and asked that his client be permitted to enter bail for his appearance when wanted. The Judge said that bail would not be accepted unless extraordinary circumstances were shown to exist, and directed counsel to consult with the District Attorney. After the lawyers had conferred, Keck filed an affidavit in which it was substantially set forth that he had many important business matters to arrange which required immediate attention, etc. The Judge finally accepted bail in the sum of \$10,000, the Fidelity and Deposit Co., of Maryland, becoming Keck's surety, pending the disposition of the motion for a new trial.

### FIRST DAY OF THE TRIAL.

When Keck was arraigned in court for trial on Tuesday there was a throng of well known persons present including a number of local jewelers and others interested in the proceedings. It was noted at the start that the alleged smuggling had attracted unusual attention and as the proceedings progressed the manifestations of interest became more pronounced, the attendance being stimulated at each succeeding session. On being placed at the bar of justice, Keck had quite an array of able counsel. He had two Cincinnati attorneys—Francis B. James, and August H. Bodey—and A. S. L. Shields, of this city. District Attorney James M. Beck was assisted in the prosecution by Harvey K. Newitt, who was an assistant district attorney under Ellery P. Ingham, the latter being United States District Attorney when the alleged smuggling occurred. Another of Mr. Ingham's former assistants, Colonel Robert Ralston, was associated with Mr. Beck in the prosecution. Charles S. Hess, of New York, was in attendance in the interests of the Diamond Cutters' and Importers' Protective Association.

Keck had been indicted on two bills, one charging smuggling and the other conspiracy. In the latter bill it is alleged that he conspired with Captain Frank Loesewitz, of the steamer *Rhynland*, and a person known only as Von Hemelreick, to import the diamonds into this

country with intent to commit a fraud against the United States. There is an indictment against the captain of the steamer and against Von Hemelreick who is understood to be in the diamond trade in Antwerp, but Keck's case was the only one placed on trial.

In opening the case for the Government, Mr. Beck said: "This is the most important case to the Government that will be tried during this session." Mr. Beck then explained the provisions of the statutes and detailed to the jury the manner in which the alleged violations took place. Continuing he said: "We are prepared to show you that Mr. Keck was in Antwerp, in February, 1896, and with Von Hemelreick and Loesewitz, visited a cafe. Keck had in his possession the box containing 563 diamonds, which were seized on the *Rhynland*. Instead of going before our Consul there and having them invoiced, he had them given into the possession of Captain Loesewitz, to carry to this country. The captain was given a piece of paper with the address of Mr. Keck's business associate in Cincinnati upon it, and requested to send the box there upon arriving in this country."

Keck, he said, who is a member of several firms and companies in Cincinnati, did not come over on the steamer *Rhynland*, but came over four days later on the steamer *Aller*, touching at New York. The address of the District Attorney was listened to with marked attention and it seemed to make a deep impression. Soon after he had concluded, court adjourned and the real work of the trial did not commence until Wednesday.

### THE SECOND DAY OF THE TRIAL.

There was an increased attendance at the second day of the trial. A delegation of Keck's Cincinnati friends was on hand and so were a large number of local lawyers. There were also many Government office holders, some Secret Service men being in the assemblage. Mr. Beck sprung a big surprise at the start. He had his star witness for a beginning, who proved to be Captain Loesewitz. The latter is a man of large proportions and has voice enough to be heard high above an ordinary storm at sea. He does not speak or understand the English language very well, and this led to some confusion, but in the main the story he told was straightforward and coherent. He has been a seafaring man all his life, lives in Antwerp, and says this is the first time he was ever suspected of being a smuggler.

In his direct examination he said that on the afternoon of Monday, Jan. 27, he called in the city of Antwerp on an old friend of his, a jeweler, named Max Von Hemelreick. Max introduced him to a young man named Herman Keck, and the three went around the corner to the Alsatian Café. Here they drank beer and chatted. Max said that Keck was anxious to have a package taken to America, and he handed Loesewitz a small white box, wrapped in paper and sealed, with the remark that it contained nothing valuable. Keck repeated this assurance, and wrote on a piece of paper, which he later handed to the captain, the address: "F. Von Recht, 21 West Fourth

street, Cincinnati, Ohio, United States of America." To this address the captain was to mail the package when he reached Philadelphia.

That night Loesewitz left for Liverpool, and from there brought the *Rhynland* to this port. In the meantime word that a man named Keck had sent diamonds on the ship reached the custom officials, and they sent men here. The witness described the arrival of the authorities on his ship, and told how he had promptly handed them the box. On cross-examination, Loesewitz said that he had before brought packages of small value over for friends, but had reported them to the custom house officials. The box with the diamonds in it, he said, had not been reported, and he had permitted the custom house officers to leave the ship and go on the wharf without telling them of this box. The witness said that he never heard of Keck before he met him in Antwerp, and he recognized him in Philadelphia at the time of the Commissioners' hearing by his face and not by his name. Loesewitz said that he had lived many years in Antwerp and was born there. He could not recollect having heard of Franz Von Recht, said to be a celebrated diamond cutter of that place. He could not remember whether he had seen Von Recht's picture in newspapers, but he had heard of a party going to America and establishing a diamond cutting business. He claimed he was never engaged in smuggling. He was asked about a vessel he had commanded 17 or 18 years ago; he was not allowed to answer whether she was seized. He was questioned as to whether he had received any remuneration or was promised any pay for bringing the diamonds over. He answered these questions in the negative. He said that he was not promised immunity from prosecution for testifying against Keck. He added that his counsel had told him to tell the truth. Judge Butler asked him whether, by giving the testimony, he expected his chances to be improved, and he answered frankly that he thought it would better his condition.

John C. Gallen, special agent of the Treasury Department, stationed at Philadelphia, was the next witness, and he gave particulars as to the instructions under which the seizure of the diamonds was made. The gems were not on the ship's manifest. He said that just before the seizure was made he asked Captain Loesewitz whether he had a package for the Keck Diamond Co. and received a negative answer. The captain, however, said that he had a package for Von Recht, and produced the box containing the diamonds. Twenty-eight of the diamonds were apart from the others, and were wrapped in separate tissue paper. The witness said that on the day after the seizure the captain gave him a description of Keck, but that he did not give Keck's name, because he had forgotten it.

Suspecting that Keck would follow the diamonds to America, Gallen went over to New York at once to meet the incoming *Aller*, on board of which he found his man. The witness said that he asked him whether his name

was Keck, and the answer was "Yes." He then asked whether he was acquainted with Captain Loesewitz, and the reply was "No." Gallen said he told Keck that he had a package for Von Recht, and that Keck quickly responded that the package he referred to had no address on it. Gallen testified that he showed Keck his card, whereupon the latter declared that he was no smuggler. The witness also testified that the defendant had told him that importations to Cincinnati, of diamonds from the first of the year, were made by the defendant's firms to the amount of \$100,000. This, Gallen said, was not so, the importations to Cincinnati in that time amounting to about \$7,000.

James C. Cummings, special agent of the Treasury Department in New York, corroborated Gallen, and testified that he heard Captain Loesewitz say that he had a package for Von Recht, and after asking for an order for it, saw him produce it. After some further testimony Cummings was asked where he obtained the information which he first gave to Gallen and under which the latter made the seizure. Cummings declined to say. After some little discussion he was directed to answer by the Judge, and said that the information was furnished by Mr. Frankel, the secretary of the Diamond Importers' and Cutters' Protective Association.

Timothy Donohue, a custom house inspector of New York, testified that he searched Keck, who said that he was not doing any smuggling business and that his firm's trade

amounted to \$300,000 a year. Donohue said he heard Keck say to Gallen that he might have been in the Victoria Café, in Antwerp, on Jan. 27, but was not in Alsatian Café. Charles Berry, a Cincinnati letter carrier, testified that the defendant did business as the Herman Keck Mfg. Co., and the Coetermans-Henrichs-Keck Diamond Cutting Co., and that a large quantity of mail was delivered to him for these companies and for F. Von Recht.

After the prosecution had closed and counsel had engaged in a tilt over the admission as evidence of certain papers showing the connection Keck has with certain companies, an understanding was reached and Lawyer Shields opened for the defense. He made a long and vigorous argument. In the course of his address he said that it would be shown that the defendant was a reputable young business man, who, with his father before him, was well known and highly respected in Cincinnati. That the defendant was in Antwerp at the time Captain Loesewitz said he was in the café with him, was admitted, but it would be proven that he was in another part of the city and in company with some one else. There would be testimony that Franz Von Recht was a distinguished man in Antwerp by reason of the medals he had won, and his name was as well known in Antwerp as that of George W. Childs in Philadelphia. Any participation in smuggling by Keck would be proven to be untrue, and it would be shown that he carried on a large and legitimate business.

The calling of witnesses to testify to the



**CYCLES,  
HIGH GRADE.**

Agencies to Jewelers Only.

DISCOUNTS AND CATALOGUE  
ON APPLICATION.

F. KROEBER CLOCK CO.,  
360 Broadway, New York.

SOLE AGENTS FOR THE  
JEWELRY TRADE.

We call the attention of the Jewelry Trade to our new line of

**ROCOCO BELT**

FOR EITHER SILK OR

**BUCKLES**

LEATHER BELTING.

- 8078 OLD GOLD.
- 8079 OXIDIZED.
- 8083 OLD GOLD, ENAMELED.
- 8752 OXIDIZED, ENAMELED.

When ordering, state whether Leather or Silk Belting is desired.



THE DIE WORK,  
DESIGN AND FINISH  
OF THESE GOODS  
ARE OF THE  
HIGHEST ORDER.

OUR

**LORRAINE  
BELT RETAINER**

Is the simplest and most practical Belt Retainer in the market, and is equally satisfactory for Leather or Silk Belting.



FRONT VIEW.

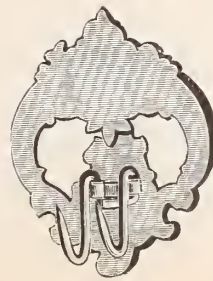

BACK VIEW.

**BIPPART & CO.**

MANUFACTURING JEWELERS,

NEWARK, N. J.

good character of the defendant was then begun. The witnesses examined were Mayor John A. Caldwell, of Cincinnati; Leopold Kleybolte, president of the Western German National Bank, that city, and Jacob Dorst, Louis F. E. Hummel, Edward G. Lohmeyer, and H. H. Mithoefer, jewelers of Cincinnati and Constant and Franz Von Recht. Constant Von Recht, a 24-year-old son of Franz Von Recht, testified that he had lived in Antwerp until last February, when he came to America in company with Keck on the steamship *Aller*. Since then the witness has resided in Cincinnati, where he is employed in the diamond cutting business. He said that his father left Antwerp in March, 1895. Counsel for the defendant asked a number of questions for the purpose of bringing out the fact that the name of F. Von Recht frequently appeared in the newspapers in Antwerp, where the latter had won medals by distinguished acts, one of which was the polishing and cutting of a large diamond for the Exposition. The questions were objected to by District Attorney Beck, and were ruled out.

The witness testified that he saw Keck in Antwerp in January, in 1895, after he had received word in a letter from him from Hanau. Young Von Recht said that he was with Keck on the afternoon of Jan. 27, which is the time that Captain Loesewitz testified he was with Keck in the Alsatian Cafe, when Van Hemelreick handed Loesewitz the small box with the diamonds in it, and Keck gave the captain a piece of paper with the address of F. Von Recht, 21 West Fourth St., Cincinnati, O., on it. The witness said that he was with Keck at the office of Coetermans from 3 o'clock in the afternoon on that day to 5 or half-past 5 o'clock. The witness had received the letter the day before, which informed him that Keck was coming. He said he came to America with Keck, but brought nothing with him in the nature of diamonds. On cross examination the witness said he never saw Keck and Hemelreick together, and he did not know whether they knew each other. He was asked by the Judge how he fixed the date of Jan. 27, and he said that he remembered it because it was just a week before he left Antwerp.

Franz Von Recht, the father of the preceding witness, was also called to the stand. He testified that he had been in Cincinnati 14 months, and that he came over to cut diamonds. He was acquainted with Captain Loesewitz and saw him in Antwerp. He was asked some questions relative to his cutting the large diamond in 1894 for the Exposition, and the many mentions of it in the newspapers, but the court ruled that the questions were irrelevant. The witness said that he never at any time had talked with Keck regarding smuggling, and never knew that he was going to do any smuggling. The parties for whom he works in Cincinnati, he said, only deal in rough diamonds. On cross examination it was brought out that the wit-

(Continued on page 24.)

## St. Louis Devastated by a Cyclone.

ST. LOUIS, Mo., May 30.—At 5 o'clock P. M. Wednesday a tornado struck St. Louis, and the loss of life and property is so appalling that it is as yet impossible to appreciate the extent of the disaster. The hurricane struck first in the southwestern suburbs, and from thence went east-north-east through the city, tumbling down like chaff houses, churches, factories and everything else in its way. It reached the river somewhere below Chouteau Ave. and tore on upon the levee as far north as Washington Ave. The main portion of the tornado leaped the river and went over to East St. Louis, creating enormous damage and loss of life in the portion of that city called "The Island," which is nearest the river. A summary of the damage reveals the fact that there are at least 7,000 houses seriously damaged in St. Louis, a very large proportion of which are absolutely ruined and are uninhabitable and unserviceable.

In East St. Louis 1,000 houses are gone beyond redemption. The loss of life in St. Louis will foot up fully 250; in East Louis 175; the number of injured it is hard to compute. Many of the injured will be incapacitated for months, and it is safe to say that 1,000 persons have been injured to some extent, many of course, not at all seriously. After looking at the wreckage it seems almost a miracle that the number of the dead is not in the thousands. The damage to property is very hard to arrive at; some estimates place it as high as \$50,000,000, while very few go below \$20,000,000; it is safe to place it somewhere between these two figures. That portion of the city that was swept is not what is commonly called the down town district, but is known as the "south side" and begins just south of where the railroads run through the city from east to west.

It seems to be the common opinion that two "cyclone" clouds met just over LaFayette Park, which is bounded by LaFayette, Park, Missouri and Mississippi Aves., and from thence east, the worst damage was created. This park is only 20 acres in extent, but was considered one of the most beautiful spots in St. Louis. Magnificent trees, beautiful walks, Chinese pagodas and a music stand; a small lake with pleasure-boats and swan-houses, and two or three rustic bridges combined to make it a lovely place. Surrounding it on all sides were beautiful residences of substantial citizens, and private "no thoroughfare" places where beautiful homes were located. Now every house in this district is almost unrecognizable. Heavy stone houses are literally knocked to pieces. Beautiful churches are literally swept off of the earth. To the man who has not seen the wreck and ruin this may seem strong language, but it conveys only part of an idea of what has occurred. The park itself, which every St. Louisian looked upon with pride, is a wilderness. If there is a tree which is anything like it was before, the writer did not see it; many of them are torn up by the roots; others are denuded entirely of bark and leaves, and

stand without a single blade of green on them to denote that they were ever the pride of a most beautiful city park. The Chinese pagodas and the music stand are scattered in various portions of the park. The walks cannot be distinguished from the greensward, as pebbles and sand are scattered where they never were before. The iron fence and the iron electric light poles are twisted into fantastic shapes, and the whole place breaths such an air of desolation that it makes one heavy hearted to look at it.

But leaving this park and going further east one comes upon the homes of the poorer class, and it is among these that the principal loss of life occurred. The more substantial houses gave a premonition of warning at least, but the shells that covered many of these poor people came down with a crash, and in one lodging house 16 people have been taken out dead. This was at the corner of 7th and Rutger Sts. In addition to all these all of the steamboats in the harbor to the number of a dozen or more were seriously damaged, two being sunk. One of them, the J. J. Odill, exploded as she sank and killed and drowned a dozen people. Several were so seriously damaged that they cannot be repaired. The upper portion of the stone approach to the Eads bridge on the Illinois side was demolished, and so many unaccountable things occurred that it would take a volume to contain the accounts.

Following is a list of the casualties among the jewelers:

Henry Lowenstien, 1236 S. Broadway, had the sky-lights broken in his store. Quick work with tarpaulins prevented serious damage to the stock.

Ger. Eckhardt, 1242 S. Broadway, sustained heavy loss. His front windows were blown in and the roof fell upon many fine clocks that were stored in the rear part of the store. His loss will foot up several thousand dollars. He is preparing to move his stock to the store formerly occupied by Henry Droste, 6th St. near Olive St.

Wm. Mauch, 1436 S. Broadway, had his front windows blown in and the stock was damaged to the extent of fully \$500. Mr. Mauch's residence at 3327 S. Jefferson St., was badly injured, the loss there being over \$2,000.

J. C. Wegener, jeweler and watchmaker, 1522 S. Broadway, sustained comparatively slight losses at his store, but his residence at 3416 Chippewa St. was damaged to the extent of \$1,500. He is a lucky man, however, as he carries cyclone insurance.

J. F. Schmitt, 1545 S. Broadway, lost fully \$1,200 at his store and residence. One of the landmarks of the vicinity was a large wooden clock in front of Mr. Schmitt's store and residence, the dial of which was 20 feet high. The splinters of the clock now decorate various parts of the neighborhood.

G. Schull, 1321 S. Broadway, has a sadly battered store, but was busily at work putting everything ship-shape when THE CIRCULAR correspondent saw him. Rings of all kinds had been thrown promiscuously into a box, and will require long labor to separate them.

Diamond pins, studs and earrings were in the same state, the cards to which they were attached being covered with a thick layer of grime and dirt.

The residence of S. A. Rider, president of the S. A. Rider Jewelry Co., 2013 S. Compton Ave., was seriously damaged.

The house of Mr. Hagen, salesman for A. Kurtzborn & Son, was practically ruined. It is situated on Compton and Russell Aves.

The store of H. Chambers, corner of Park and Mississippi Aves., was almost totally demolished. Two clocks still stand guard to show where a complete jewelry stock formerly stood.

Wm. Loeffel, 1224 S. Broadway, sustained comparatively slight damages. A sky-light came down with a crash and some cases were broken, but in comparison with the awful devastation in the neighborhood his loss is very small.

The stores in the central part of the city sustained very little damage from the hurricane. Most of them had a pane of glass or two or a sign blown down, but after the reports commenced to come in the dealers were all thankful they were alive.

The St. Louis Clock and Silver Ware Co., 409 N. Broadway, had all their signs blown down. O. J. Pfeffer, treasurer and manager of the concern, sustained serious damage at his residence, 1322 Dillon St. The roof was raised off the house, which was flooded by the heavy rain that fell for two hours after the tornado.

The beautiful home of D. C. Jaccard, of the Mermod & Jaccard Jewelry Co., was situated in Waverly place, near Latayette Park. The roof was blown off and the building sustained serious damage. Several employes of the Mermod & Jaccard Jewelry Co., who lived in the district covered by the worst part of the storm, had their all swept away in the general destruction.

The Southern Hotel was struck by lightning and the guests went without supper that evening. Among them were Mr. Smith, of M. B. Bryant & Co., New York, and Mr. Ettinger, of Keller, Ettinger & Pink, New York. THE CIRCULAR correspondent was told these gentlemen sought the cellar for safety. It is no disparagement to them if they did, as the storm was enough to make any man shake in his boots.

The following letter has been sent to the trade press:

ST. LOUIS, Mo., May 31, 1896.

In view of the terrible calamity which has befallen St. Louis, and in anticipation of the effect it will have upon the jewelers, I would suggest that you lay this matter before the Jewelers' Board of Trade, and recommend leniency toward the St. Louis jewelers, so that they may not be entirely crushed, as they certainly will be in arrears before long, if they are not already so. This done, I believe we will be able to take care of the unfortunates without financial aid.

Yours,

GEO. R. STUMPF,

525 Franklin Ave.

## The Suit of the Whiting Mfg. Co. vs. F. M. Whiting Co.

A number of questions interesting to silversmiths was raised in a recent motion in an action brought by the Whiting Manufacturing Company, New York, against the F. M. Whiting Company, North Attleboro, Mass., to restrain the use of the trade mark and the corporate name of the latter company. The motion was for a preliminary injunction restraining the use of the trade mark and name until the case should come up for trial, and was argued on Tuesday last before Judge Pryor, in Special Term, Part I. The decision of this motion involves, among other things, the nature of silversmiths' trademarks, the right of one maker to use a corporate name similar to that of another, and the extent to which similarity of trade mark is allowed.

The plaintiffs claim that in 1866 they adopted their well known silver stamp of a lion with an additional eagle's head in connection with a shield containing a "W," and have since made this device widely known to the purchasing public by advertising and otherwise, and have also made a point of making their corporate name very widely known in connection with their goods. They have, as is well known, gained a very wide reputation and have created a large demand for their goods. About 1890 the firm of F. M. Whiting & Company adopted a new silver stamp consisting of a griffin in connection with a shield containing a "W," abandoning, except on flat ware, their former device used since 1883, of a disk with rays containing a "W;" in 1895 the business was incorporated as the F. M. Whiting Company.

It was practically admitted upon the motion that the two marks as stamped on silver were indistinguishable except by dealers with the aid of glasses. It was contended, however by the defendants' counsel, Alexander Browne, of Boston, that silversmiths' stamps are in no sense trade marks and should not be protected by the courts as such. He maintained and produced affidavits of employes of the defendant company to show that the only purpose of the silversmiths' stamps and their only use are to indicate to the experienced dealer the name of the maker in order that the dealer may know where to send goods for repair and where to send for duplicates; in short, that the stamp is a private mark and not a trade mark; that the public knows nothing and cares less for the stamp, and that it is often wholly omitted at the request of the retailer; moreover that owing to the size of the articles and to the maker's desire to render the mark inconspicuous, any silversmiths' stamps are mere blurs which however dissimilar the devices may be, are indistinguishable by the public, and often by the dealers themselves; and that in any event the uses of the stamps are such that the manufacturer cannot be injured by their imitation, for the trade in duplicates cannot be diverted from the maker, and the maker is glad to be relieved of goods sent for repair. Mr. Browne further argued that the injunction should be denied, because, as he claimed, the defendant

had adopted and were using the mark without any intention of injuring the plaintiffs, and moreover that the plaintiffs had lost any possible right to relief by lapse of time and by purchasing from defendants goods bearing the mark complained of.

Plaintiffs' counsel, Ralph S. Rounds, produced, however, affidavits from several leading silver manufacturers and dealers to the effect that the chief use and value of a silversmiths' stamp lay in the fact that it enabled the purchasers to determine the make of the goods that they were buying, that the public does observe and remember such stamps upon goods and that such stamps are of great importance and value to their owners, as making their reputation available to them in sales. The plaintiff company also showed by affidavits that they adopted at the start the policy of building up a reputation and business with the general public as well as with the trade, and that their silver stamp has come to be recognized by the public as indicating make and as guaranteeing the quality and fineness of the goods; that their wholesale as well as their retail trade is dependent upon their stamp which has thus come to be of immense value to it. Accordingly, Mr. Rounds argued that the plaintiffs' silver stamp is considered, advertised, and valued by them as a trade mark and not as a mere private mark; that to the plaintiffs it served the purposes and had all the characteristics of a trade mark and that whatever defendants' silver stamp might be, a plaintiffs' stamp is a trade mark and is to be protected as such, and that the same is true of the leading silversmiths of the country.

As to the similarity of the two stamps, the plaintiffs instanced by affidavit a number of cases where retail dealers in New York and elsewhere had been deceived by the defendants' mark upon special examination made to determine where to send the pieces for repair or replacement or to be credited as returned, and also a case in which a retail dealer had mistaken plaintiffs' stamp for defendants' in ordering similar goods. Mr. Rounds argued that the defendants had admitted the confusing similarity of the two marks and that in any event the similarity was put beyond question by the actual confusion caused in the case of experienced dealers. He also contended that the marks as appearing upon the examples of silver submitted were evidently so similar as necessarily to confuse the purchasing public.

As to the injury caused to plaintiffs by the alleged infringement, plaintiffs' counsel argued that although the defendants' stamp might be of such a kind, or of so little value, or used in such a way, that no injury could be caused to defendants by the resulting confusion, nevertheless the plaintiffs were and necessarily must be greatly injured, and their sales greatly impaired by the similarity, for the plaintiffs had based their business upon reputation with, and demand from the general public as well as from the trade, and as the public had come to know and rely upon their stamp as a trade mark, the infringement must

result in loss of sales. Moreover, the similarity of the marks, especially when taken in connection with the similarity of the corporate names, made it possible for unscrupulous dealers throughout the country to palm off defendants' goods as those of plaintiffs. The plaintiffs set out in their affidavits a number of instances in which large local stores where defendants' goods bearing the stamp complained of, were advertised or sold as those of the plaintiffs, and Mr. Rounds argued that upon ordinary principles and under the authorities the defendants must be held liable for such misrepresentation, and for the resulting injury to the plaintiffs, for the reason that such misrepresentation and injury are the result naturally to be expected from the use of such a mark and name. He moreover claimed that apart from all proof of direct injury, the stamp was a trade mark, and should be protected under the authorities which hold that a trade mark is property.

As to defendants' good faith, the plaintiffs contended that this question was entirely irrelevant. If the defendants chose to adopt such a stamp and name as were reasonably likely to deceive the public and injure the plaintiffs and did actually produce such result, they should, under the authorities, be

joined from continuing the infringement even though such a result was not actually intended. As to loss of right by lapse of time, etc., Mr. Rounds insisted that as a matter of fact there was no unreasonable delay after the infringement came to plaintiffs' notice and that as a matter of law and precedent, delay for the whole six years, even if coupled with small purchases from the defendants, cannot debar the plaintiffs from obtaining a preliminary injunction.

As to the similarity of corporate names, the plaintiffs argued upon the basis of the recent case of Charles S. Higgins Co. v. Higgins Soap Co., that the defendants' choice and use of a name so similar to plaintiffs' as to deceive the public and cause confusion injurious to the plaintiffs, should be restrained, even if such name was innocently adopted, upon the general principle that a corporate name is somewhat of the nature of a trade mark and that as corporations may, unlike individuals, choose their own names, they are bound to so choose them as not to infringe upon existing names, in other words, that the privilege generally accorded to individuals of using their own names in absence of actual fraudulent intent is not to be extended to corporations.

The plaintiffs argued that even apart from any question of trade mark, the defendants must be enjoined from using their corporate name, or, in any event, their trade mark in connection with their corporate name, on the theory that such use was "unfair trading" under the authorities, both old and recent, which go far beyond the trade mark law in protecting a man's business and reputation. The plaintiffs demanded a preliminary injunction for the reason that the case cannot be reached for trial before next Winter and that meantime plaintiffs' sales are constantly being injured in such ways as cannot be compensated in damages.

The defendants appeared by Louis C. Regner, of this city, and Alex. P. Browne, of Boston. The facts as presented in their affidavits were that prior to 1878, Frank M. Whiting, who had been an employe of the Whiting Mfg. Co., withdrew and formed the firm of Holbrook, Whiting & Albee, who began the manufacture of silver ware goods at North Attleboro, Mass. In 1878, F. M. Whiting bought out his two partners and continued the business under the firm name of F. M. Whiting & Co. In 1881, his father, Wm. D. Whiting, became a partner, the firm name remaining the same until his father's death in 1891, when it was changed to F. M. Whiting. The following year F. M. Whiting died, and

the business was continued by his widow, mother and two sisters. In 1895 it was converted into a stock company under the name of the F. M. Whiting Co. These being the facts, as practically admitted by the plaintiffs, there could be no contention that the name of the F. M. Whiting Co. had been adopted with any intention of confusing it with the Whiting Manufacturing Company, or with any other intention than that of continuing and preserving the business built up by F. M. Whiting; that no fraud could possibly be alleged against the defendants for taking the name under which they had been doing business for 16 years, and the surrender or abandonment of which would necessarily have meant the sacrifice of the good will of the business. Prior to December, 1895, no complaint had been made by the plaintiffs to the defendants, either against the use of the name or against the use of the so-called "trade mark." In fact, the plaintiffs had purchased goods from the defendants to the amount of \$12,000 to \$15,000, all of it bearing this so-called trade mark, during the five years prior to the beginning of this action, without objecting to it. In regard to the trade mark, it was contended that the winged beast (griffin) used by the defendants was not a trade mark, but a private mark. It was not intended to be remembered by the public, and would have no value to the defendants as a trade mark. The principal contention, however, was that there was absolutely no similarity between the trade mark of the Whiting Mfg. Co. and the identification mark used by the F. M. Whiting Co., when that of the latter company was printed large enough to be distinctly seen, while all, or nearly all marks of this kind had a family resemblance when reduced to microscopic size, and when stamped minutely on silverware the two marks bore no more resemblance one to the other than any other two stamps used in the silverware trade when taken at random.

The defendants introduced affidavits to show that when this mark was adopted in 1890 carte blanche was given the designer, who had never seen the Whiting Mfg. Co.'s trade mark, and that he took this mark for F. M. Whiting from a book of heraldic emblems. "The change in 1890 to this from the mark of a W enclosed," said the counsel, "was due to the fact that when reversed it could hardly be distinguished from the trade mark of the Mauser Mfg. Co., which was an M enclosed."

The counsel for the defendants also contended this mark had never been of any more value to them than any other private mark used merely for identification of their goods among the trade, that might have been adopted, and that the only objection they had to changing it now was the unnecessary expense they would be put to for new dies. As there was practically no allegation of fraud, the counsel insisted that no case had been made out for the Whiting Mfg. Co.

The case was submitted to Judge Pryor, Friday, May 29th, and a decision may be expected shortly.

## Every one of your customers

uses stationery in some form. Probably they would prefer to order through you if you were in position to take such orders. Write to us about it. Our specialty is fine engraving, printing and stamping for the jewelry and stationery trades only. Wedding Invitations, Reception and Calling Cards, etc., etc

**ALFORD & EAKINS,**

Successors to Henry G. Alford,



73  
Nassau  
Street,  
N. Y.

Send for Catalog

showing complete line, over 40 subjects, of the beautiful

# Rogers Statuette Groups....

Genuine American Sculpture. Popular Art at Popular Prices.

ROGERS STATUETTE CO., 441 Pearl St., N. Y.



**Providence.**

All communications for this column, addressed to P. O. Box 1093, Providence, R. I., will receive prompt attention.

William H. Draper is absent in Europe on business.

Ralph and William Hamilton and their foreman, William Lynch, have returned from a pleasant fishing trip to Connecticut.

Ulysses Racine has given a mortgage on real estate on Pine St. for \$1,000 to the Connecticut Building and Loan Association subject to a prior mortgage of \$4,000.

The annual Summer outing of the New England Manufacturing Jewelers' Association will be held on Friday, June 5, at the pleasantly situated grounds of the Hauteive Club, on Narragansett Bay.

M. J. Oppenheimer, I. M. Oppenheimer, Baltimore; A. Krundastader, Chicago; E. M. Rothman, Cleveland; T. Fred Cohen, Milwaukee and Mr. Tallman, jewelry buyer for Marshall Field & Co., Chicago, were in town the past week.

The manufacturing jewelers in this vicinity who are interested in the financial conditions of Newwitter & Rosenheim, New York, have received a statement from the receiver, Philip Rosenheim, which is summarized as follows: Assets, accounts, \$19,222.72, stock, \$5,011.36, total, \$24,234.08; liabilities, total, \$82,822.47, of which \$13,513.47 is for salaries and borrowed money, secured by the transfer of book accounts to the amount of \$17,757.23. The remainder of the liabilities consists of \$300 due a bank, and \$66,308 for merchandise all unsecured.

The Fitzgerald building was closed down the past week to allow of the annual overhauling and repairing of the boilers and engines. This affected the following concerns: Weeden & Barker, Fisher & Co., William G. Hopkins, Catlow Bros., George H. Holmes & Co., Harvey & Otis, Fowler Bros., S. S. Wild & Son, Fletcher, Burrows & Co., E. B. Thornton & Co., W. T. Sherman & Co., M. Fitzgerald & Co., Hutchison & Huestis, E. L. Logee & Co., Place, Peterson & Co., and H. C. Luther.

**The Attleboros.**

W. S. Blackinton, of W. & S. Blackinton, has returned from a trip to Europe.

Nelson S. Davis will start west in a few days for B. S. Freeman & Co. with a handsome line of new samples.

Totten & Sommer Company will, a few weeks hence, succeed Thos. Totten & Co. and J. J. Sommers & Co.

Peter B. Cushman, who died recently here, was formerly a member of the old-time jewelry manufacturing concern of Thayer & Cushman.

The new firm of Frank Fonteneau & Co. are composed of Frank Fonteneau, who was foreman for Young & Stern for about five years; Wm. F. Briggs, Attleboro Falls, formerly of the W. F. Briggs Co. who are succeeded by the new one; and Matthew J. Fagan, Providence.

**Philadelphia.**

James H. Kelly has gone to Europe for a stay of about one month.

Hamilton & Diesinger have made another effort to utilize their Chestnut St. property for building purposes. Argument by counsel for the firm for a modification of the Supreme Court's recent decree restraining the erection of the building as proposed, took place last week, and the matter has been held under advisement. John G. Johnson appeared for the petitioners.

**Pittsburgh.**

Mr. Stieren, optician, sold a piece of improved property on Second Ave., opposite the Pennsylvania Tube Works, for \$10,000.

George V. Brady, Washington, Pa., and E. H. Kennerdell, Tarentum, Pa., spent the early part of last week in the city, buying goods.

John Moss has sued Witzel & Pafenbach, Fifth Ave., for \$100, claiming the amount as the valuation of a clock which, left for repairs, disappeared.

A large plate-glass window belonging to M. J. Smit's new store, Fifth Ave., was cut and badly damaged by the fiend with a diamond mentioned before in this column.

**Louisville.**

Herman Stein, of G. A. Stein & Bro., was in the city last week.

S. Lieberman closed his auction last week on account of dull times.

M. Lorch, of the Lorch Jewelry Co., will go east this week to replenish his stock.

T. J. Pottinger, of Rodgers & Pottinger

Jewelry Co., visited his mother in Chicago last week and went east from there.

The prominent jewelry stores had their windows decorated in yellow and white last week, the colors of the women's clubs, the biennial federation of which was in session in this city.

Jos. C. Wilcox has sold out his jewelry store in Pleasant Hill, Mo.

C. D. Platt, Los Angeles, Cal., has given a chattel mortgage for \$150.

J. M. Bricker, Nevada, Ia., has given a chattel mortgage on his jewelry business for \$464.



BATES & BACON  
"FAVORITE"  
14K

## ALWAYS

Ask to see  
our



BATES & BACON  
"ROYAL"  
14K

**GOLD FILLED**

**WATCH CASES.**



BATES & BACON  
"PURITAN"  
14K

**None Better**

and

**Few Equal.**

# Don't Sell a Trunk Strap

for a leather belt! Did you ever watch a woman put on or take off a trunk strap either on a trunk or on herself? Did you ever see the strap thereafter? Then let her try our "ECCENTRIC" belt and see her delight at finding a belt that LOCKS ITSELF just as tight as she desires and opens in a second.

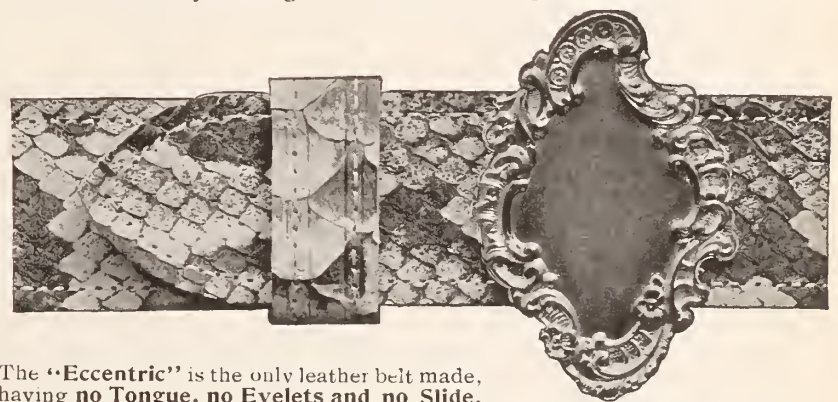

The "Eccentric" is the only leather belt made, having **no Tongue, no Eyelets and no Slide**, that ADJUSTS ITSELF and has solid front sterling buckles, which being independent of the belt will enable you to sell several different colored leathers, to match the wearer's dresses, with each buckle.

*Have you seen our Belt Hook, by using which our belt can be worn with a shirt waist?*

**Sold to Jewelers only.      Samples on Application.**

**THE FINEST BICYCLE BELT IN THE WORLD.**

**SPIER & FORSHEIM,**  **PATENTEES,**  
**31 1/2 Maiden Lane,** **NEW YORK.**

### The Full Decision Regarding the Colby Patent.

The following is the decision in full of Judge Taft, of the United States Circuit Court of Appeals, in the case involving the Colby patent in watch cases:

UNITED STATES CIRCUIT COURT OF APPEALS.  
SIXTH CIRCUIT.  
No. 396.

The Dneber Watch Case Manufacturing Company, John C. Dneber, President, and Winthrop A. Moore, Secretary and Treasurer,  
Appellants,  
vs.  
Royal E. Robbins and Thomas M. Avery,  
Appellees.

Submitted April 16, 1896.  
Decided May 12, 1896.

Before Taft and Lurton, Circuit Judges, and Hammond, District Judge.

This is an appeal from a decree enjoining the infringement of a patent. R. E. Robbins and Thomas M. Avery, as trustees, held the title by assignment to a patent No. 287,001, issued on October 23, 1883, upon an application made February 1, 1883, to Caleb Colby for a new and useful improvement in stem winding watches. It was averred in the bill and appeared in the evidence that the Dneber Watch Case Manufacturing Company had taken a license from Robbins and Avery of the following patents for improvements in watch cases:

No. 192,425, issued June 26, 1877, to Fisher & Lucas; No. 220,916, issued October 28, 1879, to E. C. Fitch; No. 287,001, issued October 23, 1883, to C. K. Colby; and No. 312,856, issued February 24, 1885, to George Hunter.

On the thirteenth of February, 1891, the license was terminated because of the failure of the defendant company to make returns and payments in accordance with its provisions. The defenses set up in the answer were want of novelty, anticipation and non infringement.

The Colby invention relates to the class of watches known as stem-winding watches, in which a key or stem arbor passes through the hollow stem of the case into engagement with the winding arbor of the watch movement, so that by the rotation of the key the watch may be wound. By its longitudinal movement within the stem, the key may be retracted from the winding arbor of the movement sufficiently to allow the movement to be easily lifted out of the case or inserted therein. The gist of the device is in providing a spring latch within the hollow stem by which the key and stem may be latched to each other in such a manner that the key will be held in its inner position but will yield upon effort and allow the key to be retracted a certain distance when the spring will again operate as a latch to secure the key in the second or outer position from which it can, by another effort, be pushed back to its first position. The patent describes the essential feature of the device "as an elastic or spring latch attachment of the stem with the key whereby the latter is free to rotate, but is prevented from being moved longitudinally, except by a special effort." The specifications and drawings describe the various forms of the device. In some of them the spring latch is attached to the stem and engages in a circumferential groove upon the key and in others the spring is attached to the key and engages in a circumferential groove on the stem. In others a shoulder is substituted for the groove.

In others a shoulder is substituted for the groove.

Figures 1 and 2, 6 and 7, 10 and 11 and 12 in the Colby patent give a sufficient understanding of the operation of the device and its variations. The figures are as follows:

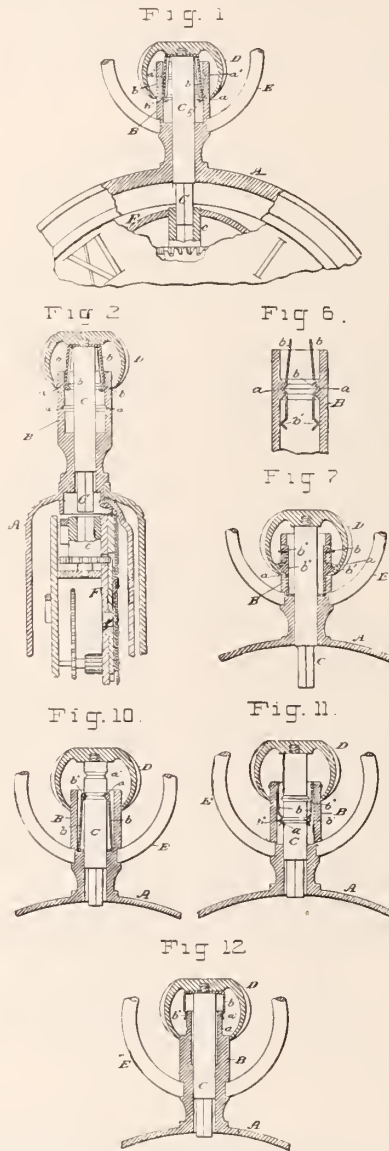

The inventor describes the purpose of his invention as follows:

"My invention relates to a stem-winding pendant for watches, being especially adapted to that class of watches wherein the back of the case is permanently closed and the movement, or the ring in which it is mounted, is hinged to the cup-like case. My pendant may, however, be used in any watch-case.

"In watches having stem-winding pendants the key in the pendant passes into the movement and engages a socket or square in or on the winding arbor, and before the movement can be lifted out or turned on its hinge this key must be disengaged from the movement by withdrawing it far enough to clear the latter. My invention provides a ready means for doing this.

Figure 1 is a vertical mid-section of a watch pendant

provided with my improvements, the plane of the section being taken edgewise of the watch-case, and the key shown as protruding into the hollow of the winding arbor.

Figure 2 is a similar section taken at right angles to Fig. 1, showing the key withdrawn, so as to permit the movement to be lifted out.

"A is the watch-case. B is the tubular stem attached to the case in the usual way. C is the key and D is the crown attached thereto to form a head or thumb-piece, by which the key is turned in winding. These parts, per se, are common in stem winding and setting watches.

"a and a' are two internal circular grooves at different depths in the hollow of the stem. They form latch bearings for the rotating key. To the crown D or the key C, indifferently are secured latch spring or springs bb, preferably four in number, provided with projecting angles or parts b'. These angles spring into and engage one or the other of the grooves a a' and the springs are inserted in the hollow of the stem as shown in Figs 1 and 2. When they key is pressed clear down into the hollow of the stem the elasticity of the springs causes the projections b' to engage in the lower grooves a. The key will now be in engagement with the winding arbor C in the movement F if there be a movement in the case, and by rotating the key in the usual way the watch will be wound up. The bearing which the key finds in the neck of the stem and that which the crown finds on the exterior surface of the stem prevent any lateral play of the key, and the engagement of the latch spring b' in groove a' prevents any longitudinal movement of the key, unless some force is applied to move it. In other words, the key rotates readily, but only yields to extra pressure purposely exerted when an attempt is made to withdraw it longitudinally. If, however, it be desired to disengage the key from the movement for any purpose whatever, the operator may grasp the crown and pull on it with force sufficient to disengage the springs from groove a, when the key may be withdrawn far enough for the projection b' to engage groove a'.

The parts will now assume the position shown in Fig. 2, the key will be withdrawn far enough to be free from the movement, and it may be rotated freely in this position in the bearing found in the groove a'.

"In lieu of employing the two grooves a a' in the stem and one series of projections b' on the springs, I may employ but one groove a, as in Fig. 6, and provide the springs with two series of projections b'.

"In Fig. 7 I have shown a further modification in which the springs are mounted in the hollow of the stem, and the two series of projections b' thereon protrude through slots in the wall of the stem. A groove in the margin of the opening in the hollow crown D takes over and engages the lower one of these projections as clearly shown in said figure.

"In Fig. 10 I have shown the grooves a and a' formed in the shank of the key itself and the latch springs mounted in the stem, and in Fig. 11 I have shown the same arrangement, except that the key is provided with projecting ribs, b' and the springs have recesses a to engage said ribs.

"Fig. 12 I have shown the grooves a a' arranged exteriorly of the stem and the springs arranged to engage them in that position.

"I have shown all these forms and modifications in order to illustrate the many ways in which my invention may be carried out. The essential feature of all is the elastic or spring latch attachment of the stem B with the key C, whereby the latter is free to rotate, but is prevented from being moved longitudinally except by special effort. The annular groove or rib engaged by the spring latch I denominate an 'annular latch device' and it is immaterial whether the projecting part is on the spring or the other part, and it is also immaterial whether the spring be connected with the key or the tubular stem. The operation is the same in either case.

"The upper groove a' in the stem is not absolutely necessary, as it is not necessary that the key shall be rotative when drawn back, as in Fig. 2; but some form of stop should be provided to prevent the key from being entirely withdrawn. This withdrawal of the key is not desirable although it will do no particular harm.

"I have not shown how my key C may be employed as a push-pin for releasing the lid of the case from its spring catch, as I make no claim to this. I will say, however, that the tip of the key passes through the case spring and a shoulder on its shank rests on the latter. The retaining groove a is made wide enough to allow of the necessary slight movement longitudinally of the key. This is a common mode of constructing such push-pin devices.

"It must be borne in mind that my invention is designed to be applied only to the pendants of stem-winding watches wherein the key is mounted rotatively in the stem and projects normally into the movement to engage the winding arbor.

"I am aware that it has been proposed to provide 'key-winding watches' so-called, with a chambered stem, and to insert the key into this stem simply as a retaining pocket wherein it is held by a spring to prevent it from dropping out. In this construction, however, the key does not project into the hollow of the case, nor is it desirable or necessary that the chamber in the stem shall connect with the hollow cavity of the case, except incidentally to provide room. Keys



**W** Means everything that is first quality in Watch Glasses.

**T** They are used by more Watch and case makers than all others.

**F** Their success has induced others to copy the label but not the quality.

**It Pays** to read a live Trade Paper.

*The Jewelers' Circular*

IS ONE.

\$2.00 a year.

mounted in pockets in the stems in this manner do not or need not rotate. In the stem-winding pendant herein shown the key must project into the case and must rotate, and it is not intended that it shall ever be withdrawn from the hollow of the stem or be detached from the case."

The only claim of the patent upon which the charge of infringement is based is the first claim, as follows:

"The combination, in a stem-winding watch, of the tubular stem, a key mounted to rotate in said stem and to project into the movement and engage the winding-arbor, as shown, a spring attached to one of these parts and arranged to engage the other part to form a latch device, as shown, and the said winding-arbor, all arranged substantially as and for the purposes set forth."

The alleged infringement is made under the patent issued to W. W. Bradley and assigned to John C. Dueber, No. 411,420, and dated September 24, 1889.

The patentee declares that his invention consists in providing a watch-case pendant with a peculiar combination of devices that enables the push pin or stem to perform the three-fold purpose of winding the watch, setting the hands of same, and operating the case-spring, the details of said devices being hereinafter more fully described, and then pointed out in the claims.

The drawings of the patent are as follows:

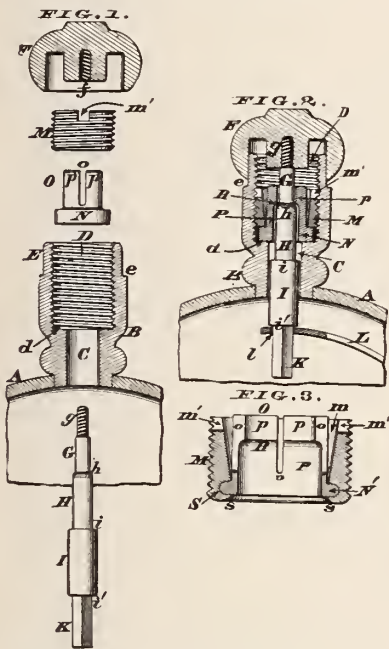

We quote from the explanation of them given by the patentee.

"Fig. 1 is an enlarged sectional elevation showing the various members of my watch-case pendant separated from each other. Fig. 2 is an axial section showing said parts fitted within the pendant and the push-pin held in its normal position by the action of the case-spring. Fig. 3 is an enlarged axial section of the spring clutch and a modified form of the keeper. A represents a portion of the 'center' of a hunting-case watch, and B is a pendant attached thereto, said pendant having at its inner end a smooth bore C opening into a screw-threaded chamber D, of somewhat larger diameter than said bore, thus forming an annular bearing D in said pendant. The opposite or outer end of said chamber is open and this end of the pendant is reduced in diameter, so as to form a neck E and an annular shoulder e, said neck having the hollow crown or knob F fitted around it, which knob is screw-threaded internally as at f, to admit the screw g at the outer end of the shank G of the push-pin or stem.

"h is a rounded or inclined shoulder formed at the junction of said shank with the spindle H of push pin I, the latter having a shoulder i at its upper end and a similar shoulder i' at its lower end, which latter shoulder i' is formed where said pin or stem I joins the square arbor K. This arbor traverses a circular eye L in the free end of the case-spring L, and is arranged to operate either the winding or setting mechanism in the usual manner.

"Engaged with the screw-threaded chamber D is a hollow nut to keeper M, whose bore m is somewhat larger in diameter at top than at bottom, as more clearly seen in Fig. 3, and the upper end of this nut is nickel or slotted at m'm' to admit a suitable turning implement. This nut may either bear against the spring-latch, or it may be coupled together; but as seen in Fig. 2 said nut is screwed down until it comes in contact with an annular collar N at the inner end of said clutch O, the latter having a series of longitudinal slots o extending from its upper end almost to said

collar. Furthermore the inner portion of this clutch is chambered out at P, thereby affording an annular shoulder R between said chamber and the spring-prongs p."

Figure 2 shows the parts properly fitted together and in their normal position.

"When the various parts of this pendant are properly fitted together and occupy their normal positions as seen in Fig. 2, the stress of spring L advances the push-pin I and forces its shoulder h against the shoulder R of the clutch, thereby causing the crown F to recede a slight distance from the shoulder e, in which position of the push-pin the arbor K is in gear with the winding mechanism, but by pushing against the crown until it strikes the shoulder e the spring L will be bent sufficiently to liberate the 'front back' of the watch and allow it to fly open and by properly turning said crown the watch will be wound in the usual manner. This free opening of the case-spring and winding of the watch is due to the fact that the spindle H now occupies the chamber P of the clutch while its prongs p surround the shank G, but do not grasp the same. Therefore, the opening of the case and winding of the watch can be performed without producing any frictional action of the spring-clutch; but when the hands require setting sufficient force is exerted against the crown F to pull it forward until the shoulder i comes in contact with the inner end of collar N, which limits the advance of the push pin and brings its arbor K into communication with the setting mechanism. This advance or outward pull of the push-pin or stem causes its rounded shoulder h to act as a wedge that gradually opens the clutch-prongs p and allows the spindle H to be grasped by them, as seen in Figure 4. Consequently the clutch has now a frictional hold around said spindle, and when the push-pin is turned either to the right or left said clutch turns in unison therewith, because it is not engaged with the chamber D; neither is it secured tightly within said chamber by the nut or other keeper M. After the hands have been set, sufficient pressure is exerted against the crown F to overcome the grasp of the clutch and force the push-pin or stem back to its original position, where it again assumes its normal function of opening the case and winding the watch."

The court below held that the Colby patent was for a new and useful device, and was valid, and that the defendant's device was an infringement thereof, and after the hearing upon the merits entered a decree for a perpetual injunction and referred the question of damages to a master. Pending the reference this appeal was taken, under section 7 of the Court of Appeals act, from the decree below as an interlocutory order granting an injunction.

Taft, Circuit Judge, delivered the opinion of the court.

The decree of the circuit court must be reversed for two reasons: first, because the Colby patent, in view of the state of the art, did not involve patentable invention; second, even if the Colby patent can be sustained, its scope is so narrow, in view of prior inventions, that the defendant's device is not an infringement.

The object of Colby's device was to permit the movement of a stem-winding watch to be lifted out of the case and freed from the stem-arbor or key by withdrawing the key from its connection with the movement back into the stem, and so securing it in both its outer and inner positions in the stem that it could not be moved from either to the other without an effort. The outer and inner positions of the key were secured by spring latches. The spring latches were effected by a spring attached either to the inside of the stem or to the key, the ends or shoulders of which took into or struck against annular grooves or shoulders on the other piece. It was old in the art to permit the movement of the stem winding watch to be removed from the case by withdrawing the key back into the stem. This is shown in the Fitch patent issued October 28, 1879. It has the ordinary stem and stem-arbor. The stem-arbor projects into the movement and engages the winding arbor. A spiral spring working between a shoulder on the inner end of the stem-arbor and the inner end of the pendant or stem, holds the stem-arbor in engagement with the winding arbor. When the movement is to be removed and it is desired to retract the stem-arbor, the owner or operator pulls the crown of the stem-arbor outward, overcomes the force of the spiral or helical spring, and withdraws the stem arbor into the stem sufficiently to permit the lifting of the movement out of the case. A similar patent by Fitch, with the helical spring placed inside the stem instead of inside the case, was an earlier patent by the same inventor. The Fitch patent, it will be observed, had not the spring latch feature of the Colby patent. The spiral spring operated merely to hold the stem arbor, by the constant force of the spring, in operation with the winding arbor, and the spring pressure had to be overcome by the operator

and continuously overcome while the stem remained retracted. The Fitch patent does show, however, the retraction of the stem from one position to another for the purpose of releasing the movement, and it uses as an agent in maintaining one of the two positions, a spiral or helical spring. It presents the same short stem arbor that we find in the Colby patent.

The Lehman patent is for a stem winding and stem setting watch, that is, a watch in which the key in the stem extends into the movement and may be adjusted either to wind or to set the watch by its longitudinal movement in the stem. In order to maintain the key in the inner and outer positions in the stem two annular grooves on the key are provided at its inner end within the case and a spring latch which is secured in the movement takes into one or the other of these annular grooves and holds the stem arbor in position either for winding or setting. The spring, like that in the Colby patent, is strong enough to hold the stem in position against any movement of the crown except by special effort. The Lehman patent thus shows the spring latch inside of the case used upon the stem arbor to secure the inner and outer positions of the stem arbor against anything but special effort. The Lehman patent, however, does not provide for an easy removal of the movement from the case by retraction of the stem arbor.

The Yager patent, invented in 1862, is a French patent for a stem winding and setting watch in which the movement may be easily taken out of the case by a retraction of the stem. The inner end of the key or stem arbor reaching beyond the stem inwardly has two annular grooves. Inside the outer rim of the case is a split spring which embraces the end of the stem arbor. As the stem arbor is pulled outwardly this spring takes into one annular groove of the arbor, and as the arbor is pressed inwardly it takes into the other and thus secures a stationary position of the stem arbor, permits its rotation in either position and prevents its disturbance except by special effort. There is no difference between the spring latch of the Yager patent and the functions which it performs and those which the spring latch in the Colby patent performs except that the spring latch of the Colby patent is located inside of the stem instead of being inside the case. We thus find in the prior art the use of the spring latch upon the stem for the exact purpose which Colby had in mind, namely, of securing the stem in two different positions, the inner and outer positions, from either of which the arbor could not be moved to the other position without special effort.

Even if it required invention to change the location of the spring latch from its position inside the case, as shown in the Yager and Lehman patents, to one inside the stem, as in Colby's device, that change was also suggested in the prior art. It is found in the Fisher & Lucas patent. That was a patent of June 26, 1877. It was not for either a stem-winding or a stem-setting watch. It was a so-called key-winding watch, but the stem of the watch was used as the place in which to hold the key. When the key was to be used as such, it was removed entirely from the stem, and applied as an ordinary key in an old style watch. When not thus used, the key fitted into the stem, and while in the stem operated as a push-pin against the spring which held the case shut, and thus was used to open the case. The key had a crown like that of the stem arbor of a stem-winding watch. The stem did not open into the case of the watch and the key did not reach through the side of the case into the movement as in stem-winding watches. The key was secured in the stem by springs attached to the key, which had annular grooves in them into which the projecting outer ends of the stem took and prevented the key from being removed from the stem except by a pull. This showed the use of the spring latch inside the stem to secure the key in a position from which it could not be moved except by special effort. It showed the spring latch operating between the stem and the stem arbor or key, although the capacity of the key for rotation in the stem was not utilized in the Fisher and Lucas patent, it plainly had such capacity. It is true the key was not used as a key while in its position inside of the stem, but it occupied the place where the ordinary stem arbor is, and so far as the function of retaining the key in one position from which it could not be moved except by special effort the spring and the groove, or in other words, the spring latch of the Fisher & Lucas patent discharged the same func-

tion as the spring latch of the Colby patent. The Colby patent is a mere duplication of the same device in the same place for the same general purpose. By putting the Fisher & Lucas patent alongside the Lehman and Yager and the Fitch patents one finds every element of the Colby patent discharging the same function without accomplishing any new result. The Colby device is possibly a neater form and works in a smoother way, but this is all. It is questionable whether, without reference to the prior art, the use of a latch spring to hold yieldingly a shaft inside of a cylinder in two different positions at different times, would involve patentable invention. Certainly it does not involve patentable invention, when we find the suggestions of every feature of it in the prior patents already referred to.

The fact that for a time the defendant was a licensee of the Colby patent cannot, of course, stop the defendant from disputing its validity in a suit for infringements charged to have taken place after the license was withdrawn. Such a fact in a doubtful case might, however, have considerable evidential force as an admission of the validity of the patent by the licensee. Here, however, we do not have a case involving doubt. More than this, the licensee embraced the Fitch and the Fisher & Lucas patents, and the admission contained in the act of accepting the license thereby loses much of its weight.

Another ground relied upon and strenuously pressed on the court for holding that the Colby patent involves invention is the fact that it has gone into very general use. The Colby device is used chiefly in stem-winding and setting watches and not in a stem-winding watch for which it was invented. It is used in connection with movements made under the Church patent, which we had to consider in the case of *Columbus Watch Company v. Robbins*, 22 U. S. Appeals, page 601. The in and out movement of the stem arbor of the Colby patent was, when united with the Church patent, readily adapted to shift the winding and hand setting train from one engagement to the other, and as the patents were owned by the same persons the Colby device came to be largely used with the Church movement. Its extensive use is due rather to the meritorious

character of the Church invention than to the fact that it has supplied a long felt want in the field of watch making.

Extensive use is only an element to be considered in a case where patentibility and invention are doubtful. Where, as here, the extended use can be attributed to something other than the mere novelty of the device, it loses its evidential force.

Second. Even if the Colby device is to be sustained as valid the prior art is so close to it that its scope must be narrowly limited. The defendants' device does not contain a spring attached either to the stem or to the key. It is attached to a hollow nut or threaded cylinder which moves with the rotation of the key and saves the grinding of the spring ends in the annular grooves or against the annular shoulders, and performs the same function in a somewhat different way. Unquestionably, if the Colby patent could be held to be a pioneer patent and one requiring a broad construction, we should hold that the latch spring contained in the Colby patent is seen in the defendants' device. But the Colby patent must be limited to the particular form shown, and in this view there is a distinguishing difference in that the spring in the defendants' device is not attached to either the key or the stem. It is held in position inside of the stem in a different way, a way which enabled the inventor to prevent the friction of the spring end against the stem or the stem arbor during the rotation of the stem arbor. This is enough to escape infringement.

The learned judge at the circuit held otherwise. An examination of his opinion satisfies us that he gave much too wide a scope to the object and the result of the Colby patent and that the benefits which he pointed out are due wholly to its connection with the Church movement in a stem-winding and setting watch. Of course Colby would be entitled to any benefit which might come from the use of his device in a stem-set watch, although he might never have contemplated its use in such a watch. But the argument that his device must have novelty and invention in it because of its extensive use must fail when it is seen

that the extended use finds its explanation in the novelty and utility of the Church movement with which it is sold, and not in anything either novel or strange in the mechanism of the Colby stem.

The decree is reversed at the cost of the appellants, with instructions to dismiss the bill.

A reporter of THE CIRCULAR called at the office of Robbins & Appleton, agents for the American Waltham Watch Co., to learn what effect the decision of the United States Court, in the Colby patent suit, would have upon the watch case and movement business. Robbins & Appleton made the following statement:

"The United States Circuit Court of Appeals has recently decided against the validity of certain patents on the pendant setting mechanism of watch cases only, known as the 'Colby Patents.' The effect of this decision is to permit the manufacture of pendant setting watch cases without license. It gives no monopoly nor control whatsoever to any case-maker. One of your advertisers has made a misstatement in claiming—'We are therefore the only manufacturers and ours the only pendant setting device used in the manufacture of pendant setting watch cases.'

"The construction of watch movements in which the winding and hands-setting train is moved into or out of engagement with the winding-wheel or the dial-wheels by the longitudinal movement of the stem-arbor, is fully covered by letters patent owned by R. E. Robbins and T. M. Avery, trustees for the American Waltham Watch Co. and the Elgin National Watch Co. It has been decided by the United States Court of Appeals that this patent is good and valid. The trade is hereby notified that each person or firm dealing in infringing movements will be held personally responsible. It should be observed that Waltham and Elgin movements are the only pendant setting watch movements made under this patent.

"With reference to the disingenuous statements in a late newspaper dispatch, we have only to say that the recent Colby patent litigation had nothing whatsoever to do with the suit which was brought a few years ago by Mr. Dueber's company against us and other movement and case manufacturers. The Dueber company simply failed in the trial of that suit and voluntarily abandoned further proceedings without any consideration."

**Imparting Elasticity**—In order to obtain a good temper and desirable elasticity for the parts requiring it, the following process is recommended very highly: The spring and other steel parts of all kinds of watches or clocks are first heated thoroughly, then well rubbed over with ordinary soap, heated to a cherry red and quickly dipped into petroleum, without the fear that it will ignite. The tempering in petroleum has the advantage that the steel parts do not become twisted, and remain perfectly white; they are therefore at once ready for annealing. The springs are upon the annealing plate or broad clock spring annealed light blue, quickly coated with tallow, and burned off twice. Springs treated in this manner will never break.

## "Diamond Dee" "Skirt Grip."

COMBINATION BELT AND SKIRT SUPPORTER  
(PATENT APPLIED FOR.)



UTILITY,  
SECURITY,  
SIMPLICITY.

**Holds the Skirt Up. Holds the Belt in Position. Holds the Waist Down.**

Sterling Silver: { 1 Inch, - - \$12.00 per doz.  
                  { 1 1/2 " - - 13.50 " "  
                  { 1 3/4 " - - 15.00 " "

Silver Plate, - - - } \$24.00 per gross,  
Gold Plate, - - - } assorted sizes.  
Black and Oxidized,

AND UPWARDS.

**DEITSCH BROS., Makers, 7 East 17th St., N. Y.**

# The Jewelers' Circular

AND  
HOROLOGICAL REVIEW.

PUBLISHED EVERY WEDNESDAY BY  
**THE JEWELERS' CIRCULAR PUB'G CO.,**  
189 BROADWAY, NEW YORK CITY.

A JOURNAL DEVOTED TO THE INTERESTS OF JEWELERS, WATCHMAKERS, SILVERSMITHS, ELECTRO PLATE MANUFACTURERS, AND ALL ENGAGED IN KINDRED BRANCHES OF INDUSTRY.

Member of the American Trade Press Association.

Our Editorial columns will contain our own opinions only, and we shall present in other columns only what we consider of interest or value to our readers. Advertising matter will not be printed as news.

Advertising rates in THE CIRCULAR are lower, considering the number of tradesmen reached by its large circulation, than in any other jewelry journal.

Notices of changes in standing advertisements must be received one week in advance; new matter can be received up to Monday.

## INFORMATION FOR SUBSCRIBERS.

### Terms of Subscription, Postage Prepaid.

	PER ANNUM.
United States and Canada, - - -	\$2.00
Foreign Countries in Postal Union, - - -	4.00
Single Copies, - - - - -	.10

New Subscribers can commence at any time.

Payments for THE CIRCULAR when sent by mail, should be made in a Post-Office Money Order, Bank Check or Draft, or an Express Money Order or Registered Letter. All postmasters are required to register letters whenever requested to do so.

Pay money only to authorized collectors having proper credentials.

**Returning Copies** Returning your paper will not enable us to discontinue it, as we cannot find your name on our books unless your address is given.

**Changing Address.** In changing address always give the old as well as the new one. Your name cannot be found on our books unless this is done.

**Discontinuances.** We will continue to send papers until there is a specific order to stop, in connection with which all arrearages must be paid; but such an order can be given at any time, to take effect at or after the expiration of the subscription. All such orders will be promptly acknowledged by mail.

**Liability.** The Courts have decided that all subscribers to Journals are responsible until arrearages are paid in full and an order to discontinue has been received by the publisher.

## THE JEWELERS' CIRCULAR IN EUROPE.

Among the Places in Europe where THE JEWELERS' CIRCULAR is on file are the following:

**LONDON**—First Ave. Hotel, Holborn, E. C.; Holborn Viaduct Hotel, Royal Hotel.

**PARIS**—Hotel de L'Athénée, Rue Scribe.

**BERLIN**—Deutsche Uhrmacher Zeitung, Jager-Strasse, 73.

**GENEVA**—Journal Suisse D'Horlogerie.

**AMSTERDAM**—Continental Club, Hotel Amstel.

**ANTWERP**—Diamond Club, Rue de Pelican.

Vol. XXXII. June 3, 1896. No. 18.

Every line of reading matter in THE JEWELERS' CIRCULAR, with the exception of the few brief extracts from exchanges, always properly credited, is written exclusively for this journal. Each issue of THE JEWELERS' CIRCULAR is copyrighted. Permission to quote is extended to other publications if such quotations are properly credited.

**The Conviction of Herman Keck.** DURING the period of every effort upon the part of Congress to increase the duty on diamonds, the reputable importers of precious stones have urged the legislators to allow the schedule to remain at a low figure, their principal argument being that an increased duty on diamonds would cause an increased volume of smuggling of these precious and easily concealable articles, with its consequent corollaries, diminished revenue to the Government and ruinous demoralization to the diamond importing industry. These urgings were heeded until the imposition of the present tariff law, which its framers started out to make one for revenue only but ended by producing a hybrid affair that has yielded neither revenue nor protection, but has wrought demoralization if not destruction to more than one erstwhile prosperous and progressive industry. The same demagogic spirit which led to the abrogation of all customs duties on raw wool, placed a duty of 25 per cent. on diamonds and precious stones. The several industries depending upon these two classes of imports have suffered in equal though varying degrees.

"It is better that there should be more smuggling than that luxuries should not be heavily taxed" was the reply of Congressman Holman to the argument of the reputable diamond importers. And so diamonds were scheduled at 25 per cent. Also there has been more smuggling; our wise Congressmen did not really think there would be and it is only recently that events have convinced even the Treasury Department that diamond smuggling has increased in volume. The first important exposition was the sixty or more letters on the subject from prominent importers published in the columns of THE JEWELERS' CIRCULAR; the second was the pitiful array of figures representing the importations of precious stones regularly passed through the custom house at New York, presented by Appraiser Bunn to the Treasury Department; the third is the conviction last week, in Philadelphia, Pa., of Herman Keck, of the Coetermans-Henrichs-Keck Diamond Cutting Co., Cincinnati, O., of the charge of attempting to smuggle into the United States 563 diamonds valued in round figures at \$7,000.

This conviction of Keck will serve to dissipate any skepticism that may exist in the minds of Congress as to the extensive smuggling of precious stones into this country. The customs authorities, already convinced that the importers' arguments are founded on rock, have exercised increased vigilance to detect smuggling, and credit for the capture and conviction of Keck is due them, though where they would have been without the co-operation of the Diamond Importers' and Cutters' Protective Association it would be hard to say. In the prosecution of this, his first case in his capacity as United States District Attorney, Jas. M. Beck received the applause of many present at the trial. The mass of convicting evidence he elicited during the three days' duration of the trial made it impossible for

any line of defense to prove effective. Keck's conviction will tend to reduce active dishonesty by inspiring fear of capture and punishment among smugglers, and it will increase the confidence among the authorities in their power to frustrate smuggling enterprises; thus by the reduction of crime the ethical condition of the people in general will be improved. If this is a minor consideration with our legislators, they may consider the material benefit to the people in the re-establishing of the diamond importing industry upon a legitimate basis, by reason of the Keck conviction serving as a forcible argument against the present diamond duty and in favor of the return to the old schedule.

## THE MORTGAGE GIVEN BY ISAAC SULZBACHER.

S. C., May 30, 1896.

Editor of THE JEWELERS' CIRCULAR:

We wish to place ourselves correct as to the item in issue of 27th, that I gave a realty mortgage for \$700. It was in this way. I bought the store into which we moved after the fire, which cost me with all improvements, including upright and counter show case, \$2,000, and I gave a mortgage for unpaid balance on the store for \$700, and \$1,300 was paid in cash; mortgage was given to the Building and Loan Association.

The mortgage was given to the Building and Loan Association, of which I am vice-president. ISAAC SULZBACHER.

## The Statement of the Assignee of the Rockford Watch Co.

ROCKFORD, Ill., May 29.—A statement of the condition of the Rockford Watch Co. has been filed in the County Court by Assignee French. The schedule is a very voluminous document of 101 pages, closely typewritten. The following are the assets: Accounts payable, \$18,751.76; bills receivable, \$5,703.91; due from sundry sources, \$2,512.87; real estate, \$90,185.14; machinery account, \$81,816.16; finished watches, \$59,599.69; cases, \$4,822.29; office and factory sundries, \$4,730.08; watches in process and materials, \$96,899.89; total, \$365,021.77.

The factory premises are subject to a real estate mortgage to secure bonds of the company to the amount of \$150,000, only \$100,000 of which bonds have been issued and these used as collateral for debts of the company. The total figures of the inventory are thus \$465,021.77. Mr. French's bond, in the sum of \$530,044, has been filed.

Phelps & Miller, San Francisco, Cal., have filed suit in the State Circuit Court against W. Friedlander, jeweler, Portland, Ore., for \$639.

J. T. Choate and James Bakie, Jr., have been appointed assignees of S. F. Goodwin, jeweler, Amesbury, Mass.

Two families in Leesburg, O., are in a dangerous condition, having been poisoned by eating dried beef. James Guthrie, jeweler, his wife and two little daughters were the first victims.

### New York Notes.

Battin & Co. have filed a judgment against Gustav A. Linke for \$10,80.

C. F. Thompson has entered a judgment for \$225.69 against Moritz Freudenberg.

R. L. Moorhead & Co. have entered a judgment for \$133.75 against Jos. Rothschild.

Adolph Hazy has given a chattel mortgage on jewelry fixtures to S. Frieden for \$500.

A judgment against B. Eckstein for \$680 has been entered by J. S. Palmer and others.

Ludwig Nissen, of Ludwig Nissen & Co., accompanied by his wife, sails for Europe, June 4th, on the *Columbia*.

Judgments against Jno. L. Disselkoe for \$165.12 and by A. Kaplan for \$71.43.

W. W. Wells and others have given a chattel mortgage on machinery for \$5,000 to the Spencer Optical Manufacturing Co.

Judge Van Wyck, of the City Court, Monday, appointed Louis H. Hahlo receiver for A. H. Seyd in the suit of Kirby, Mowry & Co.

The Brooklyn Watch Case Co., recently absorbed by the Fahys Watch Case Co., are removing their factory and plant to Sag Harbor, Long Island.

Briefs in the suit of A. C. Dalzell against the Fahys Watch Case Co. will be submitted to the referee, Hamilton Odell, Saturday. A decision is not expected before August or September.

The New York Jewelers' Board of Trade last week distributed to the creditors of the Reed & De Mars Jewelry Co., Minneapolis, Minn., whose claims they controlled a dividend of 27.6 per cent.

In the Supreme Court trial term Part VII., Wednesday, Judge Gildersleeve directed a verdict for \$215.45 for S. E. Clairmont, in his suit against Adolph Bechtold; with interest and costs this verdict aggregated \$340.13 and judgment in this amount was entered Thursday.

At a fire that started at 9 o'clock Thursday morning in a boarding-house at 217 E. 34th St., Meyer Schwartz, a jeweler, was found unconscious from suffocation on the top floor and was taken out by policemen. The rescue was a thrilling one, and was cheered by a large crowd.

The Maltby-Henley Co. have been incorporated to manufacture hardware and silver-plated ware in New York city. The capital is \$50,000, and the directors are: G. M. Beach, of Brooklyn; W. J. Henley, New York; C. B. Rogers, Meriden, Conn., and N. Burton Rogers, Danbury, Conn.

Ex-Police Captain Thaddeus C. Davis, who died May 25th, in Astoria, was one time connected with the jewelry trade. Capt. Davis was born in Kent County Maryland, in 1818, and in early life worked as a jeweler in Maiden Lane, and mastered his craft. About 1852 he left the trade to become a lieutenant under the old Municipal Police Department.

The firm of Holbrook & Thornton, silver-smiths, 427 E. 144th St., dissolved May 23rd by mutual consent, Eugene C. Holbrook retiring. William H. Thornton will continue the business at the old address, under the name of Thornton & Co. Holbrook & Thornton, the firm just dissolved, was formed but

a few weeks ago, and succeeded Holbrook & Simmons.

The Board of United States General Appraisers last week decided a protest against the ruling of the Collector on knives and forks about 6 inches long, with decorated china handles and silver blades, valued at 96 shillings per dozen pairs. They were assessed as table knives and forks at 45 per cent, under paragraph 14. The importers claimed the goods were dutiable at 35 per cent, under the same paragraph. The protest was sustained.

It was learned last week that the passenger on the steamship *Trave*, who was suspected of smuggling diamonds into this country, and was searched by the Custom House officers in Hoboken, May 21st, was Henry Elbe, a jeweler of Niagara Falls. Mr. Elbe was indignant at the outrage in searching him. Friends of Mr. Elbe in the vicinity of Maiden Lane told a CIRCULAR reporter that it would be ridiculous to believe that Mr. Elbe would smuggle diamonds.

The appeal of Francesca Thommen from the decision of the General Term of the City Court which reversed her judgment against the Jewelers' & Tradesmen's Co. was up for argument before the Appellate Term of the Supreme Court, last week, but was dismissed by consent. The suit involved the question whether the insurance company should pay Mrs. Thommen, whose husband committed suicide, the policy having a clause providing against suicide, but also providing that this clause should be incontestable after a certain period.

The New York Court of Appeals last week affirmed the judgment of Charles Pickslay against Theo. B. Starr. The suit, which was to recover \$2,500 for salary due and \$852.10 for commissions on sales, was decided in favor of Mr. Pickslay in July, 1893, and the judgment was affirmed by the General Term of the Supreme Court in February, 1894. Mr. Pickslay, who was employed by Mr. Starr for a number of years, alleged that in April, 1889, he entered into a contract with Mr. Starr, at a salary of \$9,000 per year and a commission on sales. On Christmas of the same year, Mr. Pickslay alleged that Mr. Starr, acting in accordance with a custom pursued for several years, presented him with the usual \$2,500 as a Christmas present, and that later Mr. Starr charged this to his salary account and also refused the commissions due on sales. Mr. Starr claimed that he had forgotten that Mr. Pickslay's salary had been raised to \$9,000 when he gave him the \$2,500, and that that sum should have been included in the salary.

F. A. Hubbard, Springfield, Mass., had a special sale all last week, and by making a generous cut in the prices of jewelry and silverware stirred up business to a considerable extent. The jewelry trade, in company with other lines of business, has been unusually dull the past few weeks, and Mr. Hubbard's move had the desired effect. During the first three days of the week he had an immense stock of diamonds on exhibition, and that had the effect of attracting many people to his store.

### The Plan for the New Watch Jobbers' Association.

The plan for the formation of a new association of watch jobbers is about to be sent to the jobbing trade and will be published in full in the next issue of the THE CIRCULAR. The plan, which was drawn by Elihu Root, of New York, has met with the approval of the New York firms who are active in the formation of the new association and a convention of the whole jobbing trade will be called early in July, at which this plan will be submitted.

The basis of the new association will be distinctly different from the old National Association of Jobbers in American Watches and the membership will not be determined by the old lines. The salient feature of the present plan is the provision for a rebate system which has been tried successfully in other trades. The name of the association as well as all minor details have been left for settlement by the jobbers when the convention will be held.

James H. Noyes stated to a CIRCULAR reporter Monday that a meeting of the jobbers had not yet been called but that the copies of the plan would be circulated during this week and the convention, he expected, will be held about the first of next month. He denied the rumor that the new association was to be built on the lines of the American Tobacco Co. (the cigarette trust), as in that company all goods were shipped on consignment and not sold. He said that the rebate system which it is proposed to establish, while new to the watch trade, has been in operation in several other industries and had proven successful in stopping to a great extent indiscriminate cutting of prices. The committee and others who are active in the formation of the proposed association, he said, believe that this system will be successful in the watch trade.

In speaking of the membership, Mr. Noyes said that all watch dealers whom they believed were doing a legitimate jobbing business would be invited to participate in the formation of the new association without reference to whether they were or were not members of the National Association of Jobbers in American Watches.

H. E. Tinker, Redlands, Cal., has sold out to W. A. Truslow.

The following jewelers of Wilmington, Del., have agreed to close their places of business each evening during the week except Saturday, at 6 o'clock during the months of June, July, August and September: C. F. Rudolph, Charles A. Fell, Charles M. Banks, J. T. Montgomery, J. C. Massey, L. Thomas & Co., S. H. Baynard, S. J. Schloss, Millard F. Davis, E. E. Hanf, D. P. Smyth, William C. R. Wright, Joseph Kern, H. E. Thomas & Co.

O. W. Andreae, who about a month ago was arrested upon a warrant sworn out by A. L. Delkin, Atlanta, Ga., upon the charge that he had taken two pictures engraved on gold from the latter's jewelry store, was May 28 honorably discharged after trial in the Superior Court.

## Our Traveling Representatives



Traveling representatives may consider these columns open for the publication of any news or items of interest regarding themselves or their conferees.

**S**ALES MEN calling on the Louisville, Ky., trade last week were; Louis Melchor, F. A. Hardy & Co.; Zack Oppenheimer, H. Z. & H. Oppenheimer, Frederick M. Wheeler, Dominick & Haff; Thos. H. B. Davis, Middletown Plate Co.; Samuel H. Fink, Fink, Bodenheimer & Co.; Charles E. Dorr, Gorham Mfg. Co.; C. B. Bridges, F. M. Whiting Co.; W. H. Boice, Kraus, Boice & Co.; Frank Stanborough, Carter, Hastings & Howe; M. W. Smith, Kent & Stanley Co., Ltd.; Louis Bernheim, Bernheim, Cohen & Beer; George A. Tunne, Benjamin Allen & Co.; L. E. Smith, M. B. Bryant & Co. and a representative of S. Valfer & Co.

Traveling men in Indianapolis last week included: H. P. Cutler, Crane & Theuner; Fred Carpenter, F. M. Whiting Co.; H. R. Richardson, G. A. Dean & Co.; M. L. Jacoby, Providence Stock Co.; Chas. Marsh, C. A. Marsh & Co.; Albert L. Stearns, Roy Watch Case Co.; M. Sachs, S. Valfer & Co.; M. Freidholdt, Volker & Freidholdt; J. E. Zender, for S. Harvey Asborn; H. L. Heffern, National Optical Co.; Gus Rodenberg, S. & B. Lederer; Mr. Fisher, J. M. Fisher & Co.; Herbert W. Van Houten, for C. Sidney Smith; G. V. Dickenson, Elgin National Watch Co.; S. Kaiser, Louis Strasburger's Son & Co.; and representatives of Ferd. Bing & Co. and Bawo & Dotter.

The following traveling salesmen passed through Detroit, Mich., last week: L. B. Stevens, F. H. Noble & Co.; Joseph Becker, Joseph Fahys & Co.; W. O. Lamb, George H. Fuller & Son; Mr. Cook, E. G. Webster & Son; Mr. Caw, Caw's fountain pens; Max Arnstein, Arnstein Bros. & Co.; Nate Wolf, for Sol. Lindenborn; H. H. Bradley, the E. A. Bliss Co.; Stephen P. Kent, George O. Street & Sons; W. C. Barry, Larter, Elecox & Co.; A. J. Sherrard, Enos Richardson & Co.; John W. Casé, H. F. Carpenter & Son; Mr. Harrison, Harrison & Groeschel; and Mr. Butler, George Borgfeldt & Co.

Travelers visiting Boston, Mass., during the week included: Frank Jeanne, William S. Hedges & Co.; Samuel Levy, L. & M. Kahn & Co.; Elmer E. Wood, Charles F. Wood & Co.; L. Combremont; Irving Russell, L. Tannenbaum & Co.; Frank Harmon, M. B. Bryant & Co.; W. S. Campbell, Day, Clark & Co.; W. T. Thompson, Elgin National Watch Co.; Herman A. Friese, Lewis, Kaiser & Luthy; C. L. Power, Ludeke & Power; Benjamin Posner, Wallach & Schiele; Henry Ide, H. C. Hardy & Co.

Paul Gesswein, traveler for F. W. Gesswein

Estate, New York, will represent the house hereafter on the eastern circuit, and Mr. Moore, formerly eastern salesman, will go west.

The travelers in Kansas City, Mo., last week, were: M. Oakley, Thornton Bros.; C. A. Marsh, C. A. Marsh & Co.; H. C. Rowbotham, J. Muhr & Bro.; H. B. Richardson, G. A. Dean & Co.; F. W. Adams, Simpson, Hall, Miller & Co.

Travelers last week in New Haven, Conn., were: Mr. Paine, Dominick & Haff; Mr. Elecox, Larter, Elecox & Co.; Mr. Harrison, Harrison & Groeschel; Mr. Hall, Wilcox Silver Plate Co.; and a representative of Simpson, Hall, Miller & Co.

### Canada and the Provinces.

#### TRADE CONDITIONS.

The uncertainty as to the result of the Dominion election which takes place on June 23, as affecting the tariff, is having a depressing effect upon the manufacturing and wholesale trade. Should the Liberals be successful it is probable that important modifications will be made in the tariff in pursuance of their policy, and the possibility of these changes creates a feeling of insecurity which has a tendency to unsettle business. Trade is likely to continue quiet until the contest is over.

H. J. Dreyfus & Co., Montreal, have dissolved partnership.

W. J. Shortill has commenced business as jeweler in Markdale, Ont.

The premises of J. E. Gagnon, Quebec, Que., were slightly damaged by fire last week.

W. J. Barr, of the Goldsmiths' Stock Co., left on the 27th on a business trip to Montreal and Quebec.

The estate of W. H. Sproule, Ottawa, Ont., who assigned some time since, has paid a dividend of 5¼ per cent.

Harry Allan, representing the firm of Edmund Eaves, Montreal, is making a tour through the eastern townships.

W. A. Wyllie, representing P. W. Ellis & Co. and the Meriden Britannia Co., at Winnipeg, Man., is in Toronto on a visit.

John W. Case, representing H. F. Carpenter & Son, gold and silver refiners, Providence, R. I., now on a trip through Canada, was in Toronto, May 28.

George Robinson, who has for many years kept a jewelry store on St. James St., Montreal, has moved his establishment up town on St. Catherine St.

A moment after bidding his wife and child good-by, on May 23, Joseph R. Desmarias blew his brains out. Desmarias was 27 years of age, and was employed in R. Hemsley's jewelry establishment, St. James St., Montreal.

Among provincial buyers who visited Toronto last week were: Henry Wendt, Clifford; T. M. Ferguson, Niagara; H. A. Felt, Oshawa; W. H. Wegenast, Drumbo; P. Pequegnat, Waterloo; R. H. Jupp, Orillia; and F. W. Spangenberg, Kingston.

Ambrose Kent & Sons, 156 Yonge St., Toronto, are adding to the attractions of their establishment by putting up outside a large

and conspicuous chime clock with an automatic striking figure, made by the E. Howard Watch & Clock Co., Boston, Mass.

R. A. Dickson, jeweler, St. Peter and Notre Dame Sts., Montreal, has made some very extensive improvements to his establishment, which is now considered one of the most handsome stores in the city. Mr. Dickson only recently returned from New York after purchasing a large stock of cut glass, sterling silver goods and novelties.

### Boston.

Carl Smith, of Smith, Patterson & Co., is on a fishing trip at Orange lake, Munsonville, N. H.

President Galpin, of the New Haven Clock Co., was among the visitors in town the past week.

Andrew J. Lloyd, optician, who has been in Europe since the beginning of the year, has returned to Boston.

Chas. Foss has been enjoying a brief outing with a yachting party in a cruise along the New England coast.

Manager Rufus B. Carr, of the E. Howard Watch & Clock Co., is in New York on business for the concern.

A. W. Armington, of Shreve, Crump & Low Co., goes to Europe this week on a business trip for the house.

William A. Thompson is taking a brief vacation, having started last week on a fishing trip in northern New England.

There are a number of Masons of high degree among the Boston jewelers, and to the ranks of the 32d degree members was admitted last week Mr. Crane, of Rand & Crane.

Smith, Patterson & Co. have added a cut glassware department to their business, in charge of Joseph C. Bachelder, who is also at the head of the firm's silver and plated ware department.

Mrs. Nelson H. Brown, importer and jobber of clocks and bronzes, who has been wintering at Coronado Beach, Cal., will return this week from the Pacific coast much improved in health.

C. H. Luengene, New York, is conducting a stock reduction auction sale in the store recently vacated by Boyle Bros., the offerings comprising clocks, bronzes and plated ware from William Fenton, and fancy glassware from the Carlsbad Glass Co.

Buyers in town the past week included: Frank E. Dana, Warren, R. I.; R. H. Harris, Yarmouthport, Mass.; E. W. Folsom, Somersworth, N. H.; W. B. Studley, Rockland, Mass.; C. B. Duckworth, Pawtucket, R. I.; K. Bezanson, Moncton, N. B.

The E. Howard Watch & Clock Co. have the contract for a post clock to be erected on the new race course of the Combination Park Association, Medford. It will be visible from the grand stand and is to have two 36-inch dials. The company will also set up a fine post clock of especial design at Bar Harbor, having an illuminated pair of dials 36 inches in diameter, standing 20 feet above the street level.

**Herman Keck's Conviction.***(Continued from page 14.)*

ness received one-third of the profits for the work done by him.

THE THIRD DAY'S OF THE TRIAL.

Increased interest was displayed in the trial

on the third day, Thursday, when the defendant was placed on the stand in his own behalf. He testified that the Herman Keck Mfg. Co. which is carried on by the defendant and others, was incorporated in 1890, and the Coetermans-Henrichs-Keck Diamond-Cutting Co. was organized in March, 1895, to cut dia-

monds. Keck denied that he was in the particular café, already mentioned, on Jan. 27 last, and also denied that he saw Captain Loesewitz on that day. He said that he had not engaged in any attempt to smuggle. Coetermans, since the present trouble began, was drawing his money out of the business.

After counsel's closing addresses Judge Butler charged the jury, saying that the case was within a narrow compass. If the jury believed Captain Loesewitz, the defendant was shown to be guilty; but if they believed Keck, there should be an acquittal. The case was given to the jury after the summing up of counsel on both sides. At 4.20 o'clock, Thursday morning, the jury retired to deliberate and prepared the verdict as stated above.

## Intrinsic merit

combined with low prices, makes Cahoone's line for the coming season the most attractive ever offered to the trade.



## Cahoone's rings

this year are shown in a host of beautiful designs. Particular attention is called to the Imitation Rose Diamond and Opal Combination Rings. Sold by all leading jobbers.

GEO. H. CAHOONE & CO., Kent & Stanley Building, Providence, R. I.  
N. Y. OFFICE, 21 MAIDEN LANE.

The "Columbia" skirt-holder is the newest thing of its kind on the market. It is a metal band bent so as to form a loop for the belt. The two ends of the band are shaped to clamp together on the inner side and grip the folds of the skirt between them at the same time. This holder is exceedingly simple and strong, has no pins, hooks or buttons, and is easily adjusted or removed. Roeder & Kiersky, 527 Broadway, New York, are making the "Columbia" holder covered with leather to match the various styles of handsome leather belts of their manufacture.

Ivory tea caddies appear to please, especially when they have silver rings and feet.

# IMPORTANT.

A watch movement has been manufactured and sold by the Aurora Watch Co., of Aurora, Ill., and other similar movements are being manufactured and sold by the Illinois Watch Co., of Springfield, Ill., and the Columbus Watch Co., of Columbus, Ohio, in which the winding and hands setting train is moved into or out of engagement with the winding-wheel or the dial-wheels by the longitudinal movement of the stem-arbor. Such construction is fully covered by Letters Patent, Re-issue No. 10,631, issued August 4th, 1885, which patent is owned by us, as has been decided by Judges Blodgett and Sage, of the United States Circuit Courts, in suits against the hereinbefore named Watch Companies, and by the United States Circuit Court of Appeals upon the appeal of the Illinois Watch Company from the adverse decision of the United States Circuit Court. In such decisions the Courts hold that the said patent is a good and valid patent, and that the defendants' movements infringe the same, and injunctions have been issued restraining the said Companies from further infringement.

The trade is hereby notified of our rights under the said Letters Patent No. 10,631, and that in future we shall hold each person or firm dealing in infringing movements personally responsible.

T. M. AVERY,  
R. E. ROBBINS,

Trustees for the American Waltham and Elgin National Watch Companies.



**Trans-Atlantic Voyagers.**

TO EUROPE.

Among the passengers on *La Bretagne* which sailed Saturday were: H. Didisheim, of Hipp. Didisheim & Bro., New York, Mrs. Didisheim and Miss M. Didisheim.

John C. Day, of Day, Clark & Co., Newark, N. J., accompanied by his wife, sailed Saturday on the *Aller*.

J. H. Buck, of the Gorham Mfg. Co., New York, sailed Wednesday on the *Britannic*.

Henry Diepenbrock, New York, sailed Wednesday on the *Kensington*.

R. A. Breidenbach, New York, and S. M. Peck, Cincinnati, O., sailed Wednesday on the *New York*.

Among the passengers on the *Umbria* which sailed Saturday were: James A. Caldwell, Philadelphia, Pa.; M. Ellbogen, of the Stein & Ellbogen Co., Chicago; Samuel Druiff, of S. & S. Druiff, New York, and Mr. and Mrs. R. L. Overton, Brooklyn, N. Y.

Albert Wild, New York, accompanied by his family, sailed yesterday on the *Spree*.

FROM EUROPE.

Henry Tilden, of the Tilden-Thurber Co., Providence, R. I., returned last week on the *Paris*.

W. Michie, Cincinnati, O., returned last week on the *Spree*.

Mr. and Mrs. M. Dreicer, New York, returned last week on the *Lucania*.

Mr. and Mrs. Geo. E. Fahys, of Jos. Fahys & Co., New York, returned last week on the *Columbia*.

Eugene Unger, of Unger Bros., New York, returned last week on the *Majestic*.

**Syracuse, N. Y.**

Among the few courageous seekers after orders in Syracuse, N. Y., the past week were: Fred. Kaufman; Stephen B. Kent, Wm. H. Ball & Co., and Geo. O. Street & Sons; J. A. Watts, Windsor Silver Plate Co.; Henry E. Oppenheimer, Henry E. Oppenheimer & Co.; O. Krause, Arthur W. Ware & Co.; S. E. Vansant, Simons, Bro. & Co.; Jos. Brennan, Buffalo Watch Co.; M. Gattle, Gattle Bros.; Maj. Brooks, Brooks & Pike; Mr. Rosenbaum, L. & J. Adler; A. D. Miller, Pairpoint Mfg. Co.; R. H. Stevens, Mabie, Todd & Bard.

George E. Wilkins is expected home the first of this week from a six weeks' European trip.

S. Harry Lesser left Friday morning for a few days' stay in New York.

H. A. Williams opened a jewelry store at 324 E. Genesee St., Thursday, where he will dispose of the remainder of the stock from his former store at 348 S. Salina St.

The first annual banquet of the New York State Association of Opticians was held in Syracuse on Wednesday, May 20th. Preceding the dinner the regular meeting was held and a paper entitled "The Proper Fitting of Frames" read by James H. Morse, in which the material, method of manufacture, styles of joints, bridges and temples were clearly explained, and illustrated by a variety of shapes and styles. The banquet was served at Hotel Florence and the occasion was voted a success in all its particulars.

**Special Notices.**

Rates 75c. per insertion for notices not exceeding 3 lines (25 words); additional words 2 cents each. If answers are to be forwarded, postage stamps must be enclosed. Two insertions, 15 per cent. off; three insertions, 20 per cent. off; four insertions or more, 25 per cent. off. Payable strictly in advance. Display cards on this page will be charged at \$2.00 per inch for first insertion, subject to same discount as above for subsequent insertions.

Under the heading of **Situations Wanted** on this page advertisements will be inserted for **One Cent a Word** each insertion, no discount. This offer refers to **Situations Wanted only**. Payable strictly in advance. If answers are to be forwarded, postage must be enclosed.

**Situations Wanted.**

Notices under this heading **ONLY** are charged at **one cent a word**, payable strictly in advance. If answer are to be forwarded, postage must be enclosed.

**FIRST-CLASS LAPIDARY** with tools and benches is open for engagement. Address T. W. G., care **JEWELERS' CIRCULAR**.

**WANTED**.—Position by young man, 8 years' experience as watchmaker and salesman; am a competent watchmaker; best of references. Address Lem Clarke, 328 Whitehall St., Atlanta, Ga.

**OPEN FOR AN ENGAGEMENT**, by a first-class watch repairer and good engraver, capable of taking charge of store; own tools, highest of reference. Address X Ray, care **JEWELERS' CIRCULAR**

**FIRST-CLASS DIAMOND MOUNTER**, setter; also general manufacturing jeweler wishes permanent position; sober, industrious; A1 references; 20 years' experience. Address E. F. M., care **JEWELERS' CIRCULAR**.

**Help Wanted.**

**WANTED**.—Young man, desirous to improve himself in chronometers and fine watches. Apply to H. H. Heinrich, 102 Fulton St., New York.

**WANTED, JEWELER**; good steady place and good pay; must be honest, sober and steady. Address R. S. 210, care **JEWELERS' CIRCULAR**.

**Business Opportunities.**

**FOR SALE**.—Entire stock of jewelry, diamonds, watches and fixtures; good location and business in Hartford, Conn. Address H., care **JEWELERS' CIRCULAR**.

**ONLY JEWELRY STORE** in growing manufacturing town in New York; weekly pay roll averages \$10,000; poor health reason for selling. Address A. B., care **JEWELERS' CIRCULAR**.

\$1,200 will buy my 6,800 lb. steel-lined safe, plate glass store fixtures and balance of my clocks and silverware; will sell watches and jewelry if wanted; best opening in Oklahoma for a live jeweler. Chas. E. Rose, El Reno, Oklahoma.

**FOR SALE** in Philadelphia, a desirable business in a fine locality; clean stock about \$8,000, which can be reduced if desired; walnut fixtures, fine regulator, safes, etc; good run of work; established 12 years. Address O. E., care **JEWELERS' CIRCULAR**.

**SPLENDID CHANCE** for young man with small capital, in live town in Southside, Virginia; market place for six counties; five large tobacco warehouses; store excellently located; rent low; safe and other fixtures included. Address Mrs. Otto Salzman, Danville, Va.

\$650 00 **SPOT CASH** buys fixtures, material and optical goods of leading jewelry and optical store; established 15 years; western New York; bench work \$1,500 per year; only optician; will sell any other part of stock if desired. Address J. O., care **JEWELERS' CIRCULAR**.

**To Let.**

**TO LET**—A good office on the third floor in the Diamond Exchange Building, 14 Maiden Lane, N. Y.; now occupied by the Fletcher Watch and Jewelry Co. This office will be rented very low to May 1, 1897. Apply to Janitor, or Smith & North, 14 Maiden Lane, N. Y.

**For Sale.**

**FOR SALE**.—A Marvin fire-proof safe; outside width 54 inches, height 65 inches, depth 28 inches. R. A. Loveland, 177 Broadway, N. Y.

**FOR RENT.**

Large Office, **Corbin Building**, 5th Floor - -

Will let very low for **Three Years.**

APPLY, - - - -

**JOSEPH FAHYS & CO.,**  
NO. 54 MAIDEN LANE, N. Y.

**TO RENT.**

Back office, first floor, 20x40, new store building, 9 East 16th St., New York. All modern conveniences; fine light, suitable for silversmith or jewelers; rent very moderate.

**EDWARD TODD & CO.**

**Fox & Stendicke,**

Manufacturing Opticians,

61 **Fulton St.,**  
New York.

Javal, Schiötz Ophthalmometers, Phorometers, Skiascopic Appartus, etc., etc.

Send for Price List.

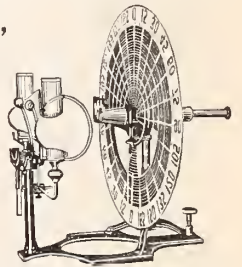

**WE HAVE ON HAND**

A Large Number of Small

**Advertising Cuts**

Specialy Designed for **JEWELERS' ADVERTISING**, such as above, at **75 Cents per Electrotype.**

SEND FOR PROOF SHEET.

**THE JEWELERS' CIRCULAR PUB. Co.,**  
189 Broadway, New York.

THE STAR OF EMPIRE WESTWARD TAKES ITS WAY!

# WESTERN SUPPLEMENT

## of THE JEWELERS' CIRCULAR

VOL. XXXII.

CHICAGO, WEDNESDAY, JUNE 3, 1896.

NO. 18.

### Chicago Notes.

*All communications in reference to the Chicago department of The Jewelers' Circular addressed to S. Parlin, 1527 Wrightwood Ave., Chicago, will receive immediate attention.*

Mr. Joslin, of Joslin & Park, Denver, Col., is visiting here.

Grant Marquardt and wife are back from their visit to Des Moines.

J. E. Heap, Montpelier, O., was a caller at the Chicago Jewelers' Association rooms on the 28th ult.

The Seth Thomas Clock Co. have placed a striking towerclock in the German Church, California, Mo.

A. B. Crawford, Flagstaff, Ariz., came back from the east with a bride, and returned to his territorial home.

G. A. Carpenter, Boston, Mass., is expected at the office of the Crescent Watch Case Co. here, the present week.

Frank Smith, for some time with C. M. McGregor, Pontiac, Ill., has opened in business in that town for himself.

G. K. Shoenberger, treasurer of the Geneva Optical Co., has returned from an inspection of his Pennsylvania mineral lands.

James F. Kelly, several years ago in business in Lead, Dak., was in town looking for a good country location for a new store.

"I have reports from Nebraska that prospects are excellent, crops are good, and dealers much encouraged," said J. W. Forsinger, Friday.

S. Goldsmith, of Goldsmith Bros., is back from a fishing trip to Webb Lake; M. Goldsmith left for a similar excursion in northern Minnesota.

T. R. Barnes, manager for Holmes & Edwards Silver Co. and Manhattan Silver Plate Co., will return this week from a two weeks' stay at the factories.

It is quietly rumored that Paul Shordiche, of Lapp & Flershem, who is not yet a benedict will be a prominent attendant at an interesting social ceremony in the near future.

May 13, before Judge Smith, a judgment by default was granted M. A. Bredt *vs.* J. F. Shambaugh, for \$428.38. Mr. Shambaugh conducts a retail store at 3902 Cottage Grove Ave.

H. M. Tenney, Lapp & Flershem, is in from his Spring trip; A. J. Perry is getting ready for the northwest; J. C. Moreland has just started for the Cripple Creek country, and Paul Shordiche will shortly leave for Michigan.

The Program Clock Co. have incorporated with a capital stock of \$100,000 to "manufacture, buy and sell program clocks and do a general merchandise and manufacturing business." The promoters are Jas. H. Egelston, Andrew J. Reems, and Elmer E. Barrett.

The American Reminder Clock Co. have incorporated with a capital stock of \$2,500 to manufacture, buy, lease or otherwise acquire clocks and other patented devices, and buy, sell and dispose of same. The promoters are E. L. Desjardins, E. S. Donnell and F. H. Mitchell.

Max Ellbogen, of Stein & Ellbogen Co., left Tuesday week on a two months' trip to Europe. Aside from a visit to his old home in Austria the trip is a business one, Mr. Ellbogen's principal purpose being the purchase of rough stones in London for his Chicago diamond cutting works.

"While there is no boom in sight the tend is toward a healthier feeling," said C. H. Knights. "The men on the road are doing a little better and the tone of the trade is healthier. Every day now we hear the expression, 'We are sure the Fall trade will be good,' which cannot be said of this time last year or the year before."

A conical mass of charred jewelry and silverware about five feet high and 15 feet in diameter is all that is left of the contents of the rear storeroom at Lamos & Co.'s, 111 Madison St., destroyed by fire on the 26th ult. The firm have two large salesrooms connected by a passageway. Shortly after noon on the 26th an employe discovered flames in the rear room and an alarm was rung in. The fire was soon put out, but not until the room and contents were a complete wreck. The firm moved to these quarters May 1, and the rear room was filled to the ceiling with cases of unpacked silverware and jewelry, all of which is a total loss. The front salesroom was uninjured and the firm will resume business as soon as the loss is adjusted. Manager Jackson estimates the damage to amount to \$16,000. Lamos & Co. carried an insurance on their total stock of \$29,500.

### Pacific Coast Notes.

The failure of A. S. Josephs, Los Angeles, Cal., is reported.

Jeweler Naher, Fresno, Cal., has removed to better quarters on Mariposa St.

F. M. Hubbard, Colton, Cal., is adding to his establishment a stock of clocks.

J. H. Crandall, Los Angeles, Cal., has opened a jewelry store in San Pedro, Cal.

Y. H. Bourdreau has opened in Modesto, Cal., with a line of watches, clocks, jewelry and silverware.

It is reported that W. Friedlander, Portland, Ore., has failed. He has given a chattel mortgage for \$7,000.

J. W. Fairchild, of Hight & Fairchild, Butte, Mont., has just returned from a three months' pleasure trip to Tahiti.

G. R. Peterman, jeweler, of Phoenix, Ariz., recently paid a visit to Harqua Hala Mining District, in the western part of Arizona.

A. E. Bocks, Woodland, Cal., who recently sold out to Keller & Praet, has purchased the store of Samuel Rich, San José, Cal., and has opened in that place.

S. Goldsmith, successor to Mr. Heller, Dibble Block, Santa Ana, Cal., has leased part of his fine store-room to Rubottom & Farwall, jewelers, who took possession June 1st.

The stock of O. M. Campbell, Petaluma, Cal., which was recently sold out by the assignee, has again passed into his hands and Campbell has opened again at the old stand.

Theodore B. Starr, jeweler of New York, who spent the Winter with his family at Phoenix, Ariz., and Santa Barbara, Cal., has returned to his home much improved in health.

Thieves recently entered the jewelry store of Shusler & Merrill, Chino, Cal., and carried away a lot of jewelry. The thieves proved to be two Mexicans who were subsequently captured in Los Angeles with some of the plunder upon them.

The case of C. D. Platt, at one time a jeweler of Los Angeles, Cal., but who has lately figured in the courts on divers charges, and was convicted of malicious mischief in throwing acid over a lot of clothing, has been granted a new trial, set for June 8th.

W. E. Doty, jeweler and optician, Phoenix, Ariz., is in southern California, where he will leave his wife for the Summer, as Mrs. Doty has not been very well. Mr. Doty will still retain his headquarters at Phoenix, although the last month he was located at Globe, Ariz.

Brothers named Sampson, of Genesee, Idaho, are reported to have discovered an opal mine five miles from Genesee that is proving to be of immense value. A large quantity of these valuable stones has already been taken out, and some of them are of excellent quality. Samples have been sent to New York and Portland, Ore., and the returns show that the owners of the mine have a fortune in sight.

The discovery was made one day while passing over the mine, the opals being found on the surface of the ledge. A tunnel has already been run, and the size and quality of the stones improve as the tunnel is run. The owners have already been offered a good price for the mine.

**Cincinnati.**

All the traveling fraternity are home and the season is practically over.

Jos. Noterman & Co. this year report an unusually large demand for school work. The fad for class pins, medals and badges is becoming a remunerative one to the jewelers.

The only event of note last week was the convening of the committee of opticians at Columbus for the purpose of presenting their views on the recently enacted Medical law. L. M. Prince presided and accompanied the other members, Harry Emrie, of Oskamp, Nolting & Co., Mr. Culbertson, of the Standard Optical Co., Mr. Wagner and Mr. Kline. A paper giving their interpretation of the law, as regarding their line of business, was read before the Board of Registration and Examiners of Medicine. Mr. Prince said he did not understand how the law could interest them as they had nothing to do with medicine, as they fitted glasses mechanically, and the diseases of the eye were not treated by them. The oculists are anxious to interpret the law to their interest and are looking forward to legislation that will destroy the business of the opticians. The board received the Cincinnati committee with cordiality and will render their opinion in a few weeks. The Legislature has closed and this body will not again convene for two years. By that time the opticians all over the State will be well organized and prepared for good, healthy legislation on their behalf. The organizing of the Cincinnati optical men has awakened the craft all through the State and letters of inquiry are coming in with a view of organizing local clubs in all the cities.

Deputy Marshal Sam Smith arrived in Williamson, W. Va., last week with John Jones and John L. Ackey, who robbed the post office and jewelry store at Louisa, Ky. They were captured in the mines at Algoma, and had a large quantity of stamps with them. They confessed to the robbery and turned up the booty.

**St. Louis.**

A. R. Marsh, of Attleboro, Mass., was in town last week.

A. S. Mermod, of the Mermod & Jaccard Jewelry Co., will sail for home on the 25th inst.

In preparation for convention week many of the St. Louis jewelers are putting their stores in extra fine shape.

Howard Rowbotham, of J. Muhr & Bro., Philadelphia, Pa., was in this city last week. He has had a successful trip.

The stock of the defunct C. Boëhmer Jewelry Co. recently bought by Wm. A. Gill, is going rapidly by the continuous auction plan.

In the suit of Mrs. Isabella Aloe against the Fidelity Mutual Life Association, the jury disagreed on the 25th inst. The suit was brought to recover a \$5,000 policy on the life of her husband, the late A. S. Aloe. This is the second mistrial.

Traveling men in town last week were: Mr. Horton, Carter, Hastings & Howe, New York; Mr. Heiser, H. C. Hardy & Co., New York; Mr. Underwood, Champenois & Co., New York; Mr. Marschutz, Julius King Optical Co., Cleveland, O., and B. Hyman, Hirsch & Hyman, New York.

The jewelry store of John Nicholson, South Centerville, Ia., was entered a few nights ago, and robbed of watches, rings and money to the value of \$125. There is absolutely no clue to the marauders.

The Walter & Hafner Jewelry Co., Hillsboro and Smithville, Tex., have incorporated; capital stock, \$20,000; incorporators, L. H. Walter, V. Hafner and Nelson Phillips. The corporation is formed for the purpose of buying and selling goods, wares and merchandise of any description at wholesale and retail.

VISITORS TO THE  
National Republican Convention  
ARE INVITED TO MAKE THE STORE OF

**THE A. S. ALOE CO.,**

...DEALERS IN...

**OPTICAL GOODS,**

THEIR HEADQUARTERS.

512 Locust Street,  
ST LOUIS.

**THE PERFECTION  
SHOW CASE**

FOR FINE JEWELRY TRADE.

WE CHALLENGE THE WORLD TO  
PRODUCE ITS EQUAL.

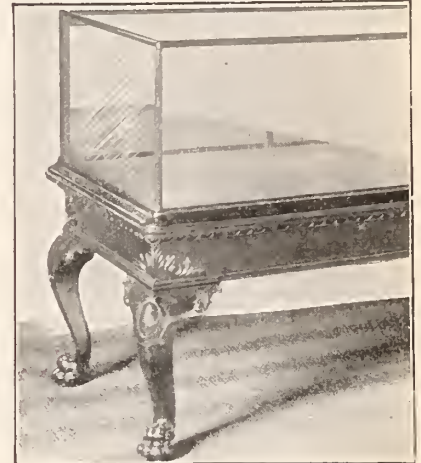

IF YOU ARE INTERESTED IN SHOW CASES AND  
JEWELRY FURNITURE, WRITE US FOR  
FULL INFORMATION.

**A. H. REVELL & CO.,**

431 to 437 Fifth Avenue, Chicago.

**JEWELERS...**  
Visiting ST. LOUIS During the  
National . Republican . Convention

Are Cordially Invited to Call  
On and Inspect the Stock of

**ARLINGTON R. BROOKS,**

—Wholesale Dealer In—

**WATCHES,  
JEWELRY  
AND OPTICAL GOODS,  
GLOBE-DEMOCRAT BUILDING,**

S. W. Cor. 6th and Pine Sts.

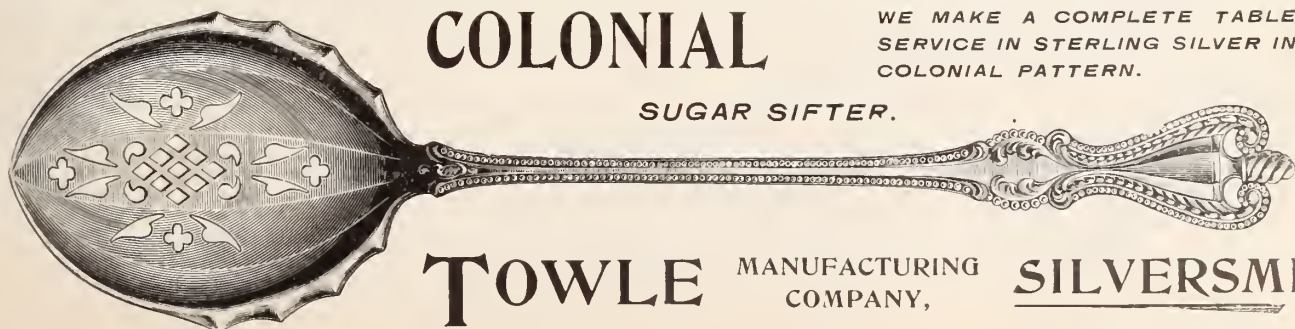

**COLONIAL**

SUGAR SIFTER.

WE MAKE A COMPLETE TABLE  
SERVICE IN STERLING SILVER IN  
COLONIAL PATTERN.



**TOWLE** MANUFACTURING  
COMPANY,

CHICAGO, 149-153 STATE ST.

**SILVERSMITHS,**

NEWBURYPORT, MASS.

JEWELERS ONLY.

### Kansas City.

Howard Potts has opened a jewelry store in Bowsorth, Mo.

E. McCoy, Polo, Mo., spent last week in the city among friends.

I. Goldenberg has opened a wholesale jewelry business at 721 Wyandotte St.

H. Hess, of Woodstock, Hoefer & Co., has returned from a successful western trip.

Chas. E. Manor, jewelers' auctioneer, held a successful sale for C. F. Jennis, Tarkio, Mo., last two weeks.

The residence of R. D. Worrell, jeweler, Mexico, Mo., was robbed last week, a large quantity of jewelry that he had recently brought from his store for safekeeping being taken.

The following out-of-town buyers were here last week: F. Mellush, Ottawa, Kan.; N. Lash, Excelsior Springs, Mo.; D. W. Williams, Independence, Mo.; E. S. Sloane, Wamego, Kan.; H. S. Zinn, Hutchinson, Kan.

A writ of habeas corpus was last week issued by Judge Scarritt, commanding Marshal Keshler to produce Herman Konrad in court last Tuesday morning to testify in the case of Mrs. Christian Harsch vs. the Metropolitan National bank. Last Fall the Metropolitan National seized the jewelry stock belonging to Mrs. Harsch, under foreclosure. Herman Konrad was placed in charge of the stock, but instead of conducting the business in the interest of his employers he packed up the goods and went to Texas. After some time had elapsed Konrad was arrested. Since that time he has been in jail. The grand jury indicted him for grand larceny. On April 21 Konrad pleaded guilty in the Criminal court, but sentence was withheld so as to allow him to testify in the Harsch case. Mrs. Harsch sued the bank for the value of the

jewelry taken by Konrad, claiming that she was not responsible for the man's misdeeds. Konrad is one of her principal witnesses.

### Detroit, Mich.

Elmer E. Vincent, 330 Grand River Ave., has removed his jewelry stock to 334 Grand River Ave.

C. E. Ritchie, formerly of Middleville, Mich., has opened a jewelry store in South Grand Rapids, Mich. He was an employe of the J. C. Herkner Jewelry Co. there.

Burglars last week entered the post office and Jeweler Sensiba's jewelry store, at Stephenson, Mich. The jeweler's safe was left untouched, but a quantity of small goods was taken.

Jeweler M. Swanson, Iron Mountain, Mich., handles a line of bicycles and to boom the trade, held a bicycle race meet on Decoration Day, the winner in which was presented with a \$20 gold medal.

The following Michigan country jewelers were in the city last week: G. W. Stevenson, Port Huron; S. A. Cleveland, Utica; George G. Nichols, Alma; Mr. Strausser, Lewiston; J. S. McLaughlin, Wyandotte; C. E. Montford, Utica; and George Chambers, Mt. Clemens.

The large retail jewelers of Detroit are agitating the question of a Saturday half holiday during the Summer months. Roehm & Son and Smith, Sturgeon & Co. are favorable to the plan and it is known that Wright, Kay & Co. would also enter into such an agreement if the rest would. Last season such an agreement failed because one of the members backed out. Trade on Saturday afternoon here is exceedingly quiet.

### San Francisco.

J. Serex, of Jos. Fahys & Co., is on an eastern tour.

S. Nordlinger, Los Angeles, was in town purchasing a few days ago.

All the leading jewelers have agreed to close their establishments at 2 o'clock P. M. on Saturdays during May, June and July.

Roland F. Allen, of the California Jewelry Co., has returned from an extended trip through Utah, Montana and neighboring States.

The Standard Optical Co. have completed arrangements for the establishment of a college of optics. Dr. R. Bruce Magee, a prominent optician of Lincoln, Neb., will arrive June 1, and expects to start the college July 1, with 25 students.

Alva R. Sheppard, a jeweler, recently murdered his cousin, Mrs. L. E. Aweny, and then cut his own throat. The woman was addicted to the use of morphine, and it is believed from a note left by Sheppard that he considered it his duty to kill Mrs. Aweny.

### Minneapolis and St. Paul.

C. Lee, Minneapolis, has started an auction sale in order to reduce his stock.

A. E. Madsen, of the Reed, Bennett Co. returned from his northern trip last week and reports crop prospects excellent.

Fred. Fiske, of F. O. Fiske & Co., Minneapolis, has returned from a business trip to Chicago and the east.

E. E. Ostrom, optician, No. 329 Nicollet Ave., Minneapolis, last week was robbed of the contents of his show case on the ground floor at the main entrance to the building.

Out-of-town jewelers visiting the Twin Cities on business the past week were: C. O. Winger, Herman, Minn.; Charles Vasalie, Waconia, Minn.; F. F. Nelson, Wilmar, Minn.; Lucien Diacon, Chaska, Minn.

E. W. Kittridge and J. K. Martin, opticians, until recently with C. A. Hoffman, Minneapolis, have formed a partnership under the firm name of Kittridge & Martin, and will do business as manufacturing opticians, at 40 S. 4th St. R. L. Dockeray, formerly watchmaker for J. B. Hudson, has rented part of the store room occupied by Kittridge & Martin, where he has established himself in the jewelry business.

### Indianapolis.

I. L. Lake, Chicago representative of the American Waltham Watch Co., will act as best man at the marriage of Jos. E. Reagan.

May 27, Madame Lillian Nordica, the great prima donna, and Zoltain Doeme, the young Hungarian tenor entered F. M. Herron's jewelry store and asked to be shown plain gold rings. Two Tiffany band wedding rings were purchased and ordered to be engraved with inscriptions. While in the store Mme. Nordica made a remark about May being an unlucky month and suggested that they wait for the all-favored month of June, but the bridegroom would not consent. The purchase of the wedding rings was the first intimation that Indianapolis people had of the approaching marriage. That night Nordica sang at the Indiana May Musical Festival with unusual brilliancy and charm. The next evening the wedding occurred at the residence of the Episcopal bishop. Upon opening the box containing the wedding rings surprise and pleasure must have been felt to find the dainty little package held together by a stick-pin of a double heart and written under it "Good Luck." The purchasers were recognized at the store and the little token of good-will was slipped in by the admiring clerk.

I. P. Riley is resuming business in Montpelier, Idaho.

H. E. Berg has removed his jewelry store from Letts, Ia.

Irwin Davidson has sold out his jewelry store in Fonda, Ia.

The death occurred recently of Archibald MacVicker, Erie, Pa.

A. S. Joseph, Los Angeles, Cal., has made a transfer of his assets.

Wm. Friedlander, Portland, Ore., has been garnished for \$1,707.

Francis Breton, Marysville, Kan., has given chattel mortgage for \$325.

The Salt Lake Clock Co. is the name of a new firm opening in business in Salt Lake City, Utah.



**ELGIN KING**  
100.00 Bicycles  
Are as perfect as the very best material and mechanical genius can make them.  
Write for Catalogue and Agents' Terms.  
Send 10 cts. for Elgin King Scarf Pin.  
Address Dept. A,  
**ELGIN CYCLE CO.,**  
ELGIN, ILL.

**PARSONS & SCHOOL**  
—FOR—  
**WATCHMAKERS,**  
PEORIA, ILL.  
Send for Circular and Terms.  
**PARSONS & CO.**

**News Gleanings.**

N. A. Soggs, Binghamton, N. Y., is conducting an auction sale.

J. Ziller, Charlestown and Huntingdon, W. Va., has assigned to Z. T. Vinson.

J. C. Ewart's jewelry store, Dalton, N. Y., took fire recently and was destroyed.

Chas. L. Dinger, Chester, Pa., has removed from 824 to 815 Edgmont Ave.

The store of Ely & Cook, Sherman, Tex., was burned out on the morning of May 27.

J. Sewell, Sistersville, W. Va., whose store was recently burned out, carried no insurance.

Arlington Ambler, Middletown, N. Y., has leased the store 50 North St. and has removed there.

E. D. Hinkle, New Oxford, Pa., has sold out his stock at auction, and left for Littlestown, his former residence.

Fred Schell, Xenia, O., will occupy part of the first floor of the new Steele building, now nearly completed, in that city.

H. H. Jones, assignee of J. W. Hull, Grafton, W. Va., is advertising to close out the stock and fixtures of the store.

Gideon F. Gallup, jeweler, Catlettsburg, Ky., and Jeannette Thornhill Atkinson will be united in marriage June 17, at The Lexington, Richmond, Va.

Hanson's jewelry store, Evansville, Minn., was burglarized early last Wednesday morning. Some \$60 in jewelry is gone, and the thief is not yet caught.

Thieves broke open the store of L. C. Adams, Colo, Ia., a few days ago, and took four gold watches, men's size, hunting cases, and Trenton movements, and two ladies' gold watches, same style cases and movements.

W. H. Wildenberger, Forest City, Pa. whose store was burnt out recently, has opened his jewelry business in the store-room adjoining his old stand, and will conduct business there during the time his own place is undergoing repair.

L. J. Levine, who conducted a jewelry business in Scranton, Pa., has been indicted for embezzlement and grand larceny. It is stated that the plaintiffs, E. D. Vosbury & Co., Binghamton, N. Y., will bring a charge of obtaining goods under false pretenses later.

Paul Granzin & Son's jewelry store, New Orleans, La., was entered a few nights ago by unknown thieves, who effected an entrance through the rear door. They were evidently frightened off, as nothing is missing. Watches and other articles of jewelry were found next morning scattered about the school room.

The will of Ruth P. Marsh, who was the widow of Benjamin Marsh, Albany, N. Y., whose will was proved on the 15th inst., was proved May 25. Mrs. Marsh died April 20th last, leaving three daughters and one son surviving her. The estate she left amounts to \$26,700; to her daughter, Anna M., she leaves one-fourth of the estate; the remainder to her other daughters, Julia Thacher Seward and Grace Ruth Marsh. Her daughter, Anna M., is appointed executrix.



THE APOLLO.



TRADE MARK

**Our Trade Mark**

**S**een on  
silver  
**S**hows  
sterling



TRADE MARK

✻ ✻ ✻ .925 Fine ✻ ✻ ✻

**J. B. & S. M. KNOWLES CO.,**

PROVIDENCE, R. I.

MAKERS OF . . . . .

**HIGH GRADE**

**Artistic Silverware.**



THE LEXINGTON.

**COMFORT AND SECURITY**  
ARE COMBINED IN  
**MERRITT'S PATENT EYE GLASS HOLDERS.**

Made by Merritt, Caspell & Co. Springfield, Mass.

GOODS ON APPROVAL.  
CORRESPONDENCE SOLICITED.

**JOHN T. PECK,**  
**WATCHMAKER**  
—FOR THE TRADE.—  
409 WASHINGTON ST.,  
Room 15. BOSTON, MASS.

FOR RELIABLE OPTICAL WORK  
SEND TO  
**JOS. FRIEDLANDER & BRO.,**  
OPTICAL LENS GRINDERS,  
9 MAIDEN LANE, - - NEW YORK.  
SEND FOR DESCRIPTIVE CIRCULAR OF OUR FRAME AND LENS CABINET.

ALL KINDS OF  
**SKELETON**  
FOR  
**SILVERSMITH**  
MANUFACTURED BY  
**CHULDER BROS**  
FACTORY AT SOLINGEN, GERMANY. FOUNDED 1850  
545 & 547 PEARL ST., NEAR BROADWAY, NEW YORK

**PHOTO-MINIATURE.**  
**PORTRAITS \$1.50**  
ON  
**WATCHES**  
The Goldstein Engraving Co.,  
1 MAIDEN LANE, NEW YORK, N. Y.

DON'T FORGET THE JEWELERS' CIRCULAR PUBLISHING CO.'S BOOK LIST when in want of any technical book in the Jewelry or Kindred Trades.

These well-known Razors, the quality of which is warranted, possess this great advantage, that they may be used for ten years before they require actual sharpening. Before using them, it is necessary to rub them on good leather strop. Le Coultre's strops (to be had with the Razors), should be used in preference to others.

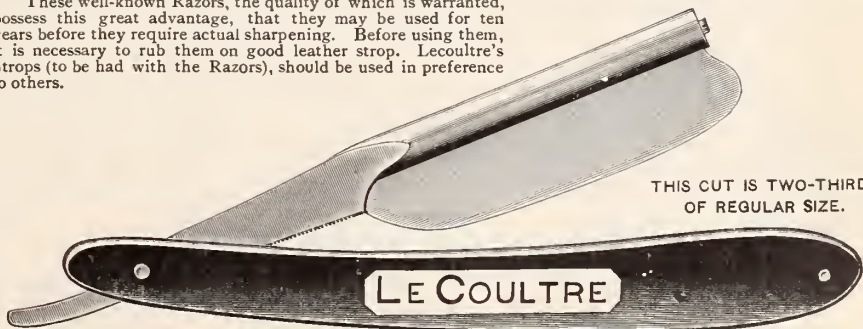

THIS CUT IS TWO-THIRDS OF REGULAR SIZE.

**LE COULTRE**

**MATHEY BROS., MATHEZ & CO.,**

SEND FOR PRICE LIST

SOLE AGENTS. 21 & 23 Maiden Lane, N. Y.

# COMBINATION PURSE AND GLOVE HOOK.

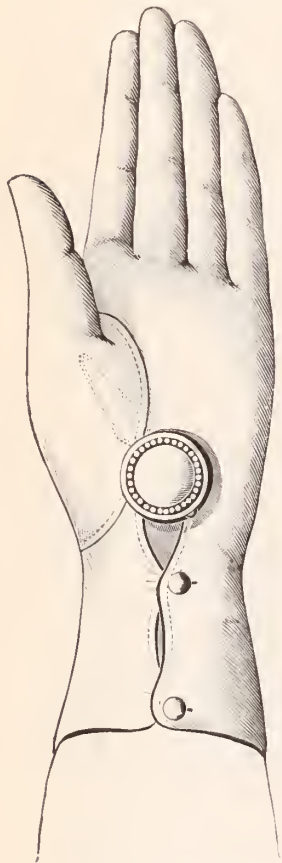

This absolutely new article is bound to have a large sale. It is extremely convenient, serves as an easily accessible carrier for small change such as is required for carfare—is securely held in the palm of the hand and saves its wearer from the insanitary practice of holding coin between the lips.

A SPLENDID NOVELTY  
MADE IN STERLING SILVER.



We are makers  
of Sterling  
Silverware  
Exclusively.

All goods  
925-1000 fine.

## F. M. WHITING CO.,

North Attleboro,  
Mass.

### Connecticut.

Thomas Downey, Watertown, has opened a repair shop.

Business is increasing at the cutlery works, Southington, full time being resumed.

Frank W. Morris, Wallingford, is now traveling for R. Wallace & Sons Mfg. Co.'s Chicago store.

Jeweler John H. Starbuck, New London, has equipped his premises with a dark room for his optical business.

Many of the leading jewelers of New Haven closed their stores in respect for Memorial Day from Friday night to Monday morning.

Newell & Jennings, counsel for the heirs-at-law of the late S. Emerson Root, Bristol, have filed notice of an appeal from the admission to probate of the will of Mr. Root, and the appeal will be entered on the docket of the Superior Court for the September term.

Salesman R. W. Miles, of the Meriden Britannia Co., has succeeded in getting an order which will put the German silver department of that factory on full time soon. The order is for the Aldine hotel, of Philadelphia, which is undergoing extensive alterations.

Jeweler M. Frank, New Haven, went out of his store Sunday morning and inadvertently left the keys in the door. He missed them in a short time and hastened back to the store with all speed to find not only the keys gone but that a thief had hauled over the goods and picked out two gold pins, two watch guards, one bracelet, a gold chain and several other articles, and had made good his escape with the booty. Luckily the diamonds, watches, etc., were locked up in the safe.

An advertisement warning the public against purchasing so-called silverware offered at astonishingly low prices in department stores and citing the cases of prosecutions of department store proprietors in New York and Boston has appeared in New Haven papers. The warning emanates from the Connecticut Jewelers' and Opticians' Association. The good effects of the new silver and gold stamping law enacted by the Connecticut Legislature through the efforts of this association are already felt by the trade throughout the State.

### Emblem Pins.

EMBLEM scarf pins are made in a variety of forms for various trades and callings. For example, there are two pins made especially for druggists' wear; one a gold mortar and pestle, the other formed of a druggist's scales and mortar combined. These are also made up in the form of watch charms, as are many other of these special de-

signs. There are made for butchers one pin with a cleaver, and another having a saw, cleaver and steel combined for a head. A scarf pin made for printers has for its head a gold composing stick. For telegraph operators there is a pin with a ticker for a head. There is a scarf pin made with a head in the form of a palette and brushes, and with the dabs of paint represented by tiny patches of enamel, for artists; for musicians, there is a scarf pin in the form of a lyre. For tanners there is a pin with a pair of tinner's shears for a head; for saddlers, a pin with a head in the form of a saddler's knife. There is a pin with a plane for a head for carpenters, a horse and rider for jockeys, a locomotive pin for locomotive engineers, a lantern for trainmen, and a ticket punch for conductors. There are pins, one with a hook and ladder for head, one with a fire engine, and another with a fire hat and trumpets made for firemen, and there are various other special scarf pins.

Some of these trade pins are worn more in the city and some more in the country; but, altogether their sale is decreasing, while the sale of society pins is increasing, more and more, men preferring the society to the trade pin.

Of emblem pins in general far more than ever before are now sold. They are worn by the members of various military, benevolent, veteran trade, and social organizations, by college societies, and by graduating classes from schools, and they are produced in a very great variety of design.—New York Sun.

### New Jewelry Businesses.

Sam Cunningham, Tarkio, Mo.

Frank J. Duffy, 543 King St., Charleston, S. C.

Geo. V. Turgeon & Co., 72 Lisbon St., Lewiston, Me.

On June A. S. Felker opened a jewelry store at 50 N. Front St., Steelton, Pa.

Samuel Baker, engaged in the jewelry business with a prominent firm in Boston, Mass., for a number of years past, is to open a new store in Roslindale, Mass., soon.

B. A. Shaw & Co., New Castle, Pa., are fitting up a room in the Vance house, Mahoningtown, Pa., and will open up shortly. The business will be in charge of E. E. Smith.

Capt. D. L. Durand, Derby, Conn., has in his possession a common pin, upon the head of which is legibly engraved all of the alphabet. The same was in perfect form but was not visible to the naked eye. Under the rays of a small magnifying glass, however, every letter could be plainly distinguished.

## PAILLARD = = WATCHES NON-MAGNETIC

ARE AS GOOD AS THE BEST.

R. A. LOVELAND, IMPORTER, 177 Broadway, New York.

**The Latest Patents.**

ISSUE OF MAY 26, 1896.

**560,691. CHRONOMETER - ESCAPEMENT.** CARL G. CRONWALL, Chicago, Ill.—Filed Jan. 27, 1896. Serial No. 576,955. (No model.)

**560,812. WATCHCASE-SPRING.** FRITZ MINK, Philadelphia, Pa., assignor to the Keystone Watch Case Company, same place.—Filed Oct. 29, 1895. Serial No. 567,228. (No model.)

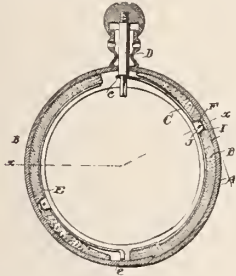

In a watchcase, the combination with the watchcase-center, of a segmental spring supporting piece B inserted therein and provided with an outwardly-flaring notch I, a segmental case-spring, resting against the face of the piece B and having a lug F projecting outwardly and tapering toward its end, fitting into the notch B under the flange of the case-center, and a pin or screw extending through the flange of the center and engaging the lug of the spring, whereby the spring may be detachably secured to the center and may be removed therefrom, without removing the segmental supporting-piece B.

**560,813. WATCH-BOW FASTENER.** FRITZ MINK, Philadelphia, Pa., assignor to the Keystone Watch Case Company, same place. Filed Oct. 29, 1895. Serial No. 567,229. (No model.)

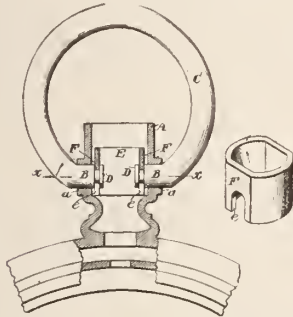

A watch-bow fastener consisting of the pendant having apertures to receive the ends of the bow, the bow having its ends inserted in the apertures and provided with heads, and the locking plate having the two faces which engage the bow and fit behind the heads flattened as at F to present flat faces to the bow-heads.

**560,863. CUFF-BUTTON.** THOMAS A. REYNOLDS, West Hoboken, N. J.—Filed Aug. 25, 1894. Serial 521,310. (No model.)



A button for link cut's comprising a flat shank having one of its terminals formed diagonally or oblique to the plane of the shank and the opposite end bent aside from the plane of the shank and provided with a T-head extending in the opposite oblique direction to the other terminal, and a button-head secured to said terminal and a shoe hinged to the T-head, the button-head and shoe extending in opposite oblique directions to the shank.

**560,895. PINCE-NEZ.** JULES COTTET, Morez-du-Jura, France, assignor to Joseph Raphael, London, England.—Filed June 1, 1895. Serial No. 551,379.

(No model.) Patented in England Dec. 2, 1893, No. 23,129, and Apr. 27, 1894, No. 8,366, and in France May 17, 1894, No. 238,583.

In pince-nez, the combination of the frame united by a bridge-piece having the base portions thereof flattened at each side and tapped with holes, screws fastened in said holes, levers pivotally supported upon



the frame by said screws and carrying at the inner ends thereof the plaquettes for resting against the sides of the nose, and the springs coiled around the screws and having one of their ends bearing against the frame and the other against the levers.

**560,898. STEM-FASTENER FOR WATCHES.** EMILE FLOTTON, Madretsch, Switzerland.—Filed Oct. 11, 1895. Serial No. 685,335 (No model.)

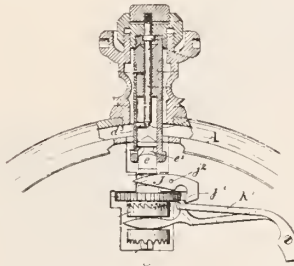

The combination with the outer case and its hollow shank of a removable inner case, a tubular stem passing through the shank and engaging the inner case, a locking spring to hold the parts in engagement and a central pin through the stem to disconnect the locking spring.

**560,926. REPEATING CLOCK.** CHARLES PRAHL, New York, N. Y., assignor, by direct and mesne assignments, of three-fourths to Sigmund Stern and Levy, Dreyfus & Co., same place.—Filed Sept. 6, 1895. Serial No. 561,685. (No model.)

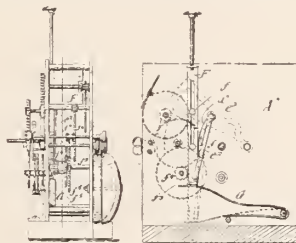

The combination, with a clock-movement, of a crown wheel on the minute-arbor, said crown wheel having eleven short teeth and one longer tooth, step-shaped cams actuated by said crown-wheel, pivotally-mounted toothed hour and minute segments, means for oscillating said pivoted hour and minute segments until arrested by the step-shaped cams, mechanism actuated by the toothed segments for striking respectively and hour and minute bell.

DESIGN 25,514. BADGE. LEWIS A. BROWN, St.



Louis, Mo.—Filed Mar. 30, 1896. Serial No. 585,494. Term of patent 3 1/2 years.

DESIGN 25,543. BADGE. JOHN M. BANKER, Saginaw, Mich.—Filed Feb. 21, 1896. Serial No. 580,263.



Term of patent 7 years.

DESIGN 25,545. BADGE. DAVID KANE, Brockton,

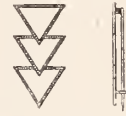

Mass.—Filed Mar. 21, 1896. Serial No. 579,658. Term of patent 7 years.

**The Only Real UNIVERSAL CASE.**

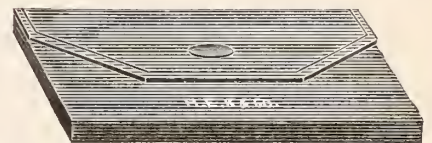
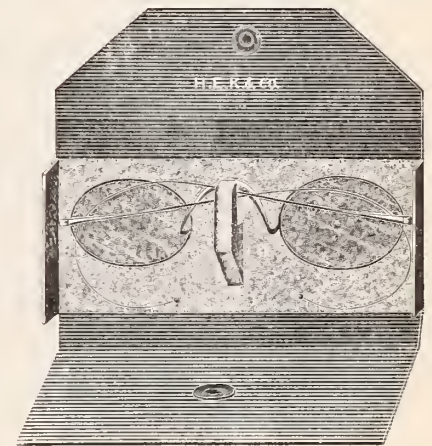

**May be used for either Riding Bow Spectacles or ANY style of Eyeglass.**

ONE great advantage of this case is that one wearing a spectacle and eye glass (or two pairs of spectacles, or two pairs of eye glasses) can be perfectly accommodated with one case—the UNIVERSAL.

**SEND \$1.50 FOR SAMPLE DOZEN.**

**H. E. Kirstein & Co., Rochester, N. Y.**

## MATTERS IN JEWELRY STOREKEEPING.

That this department shall prove mutually beneficial to our readers, it is desirable that the members of the trade generally communicate with THE CIRCULAR regarding any advantageous device or plan that they are utilizing in connection with their business.

### A Mystic Fan Clock for the Show Window.

IN Vol. XXXI., No. 11, THE CIRCULAR published the cut together with translation from *La Nature*, of a fan clock, constructed by Pontus de Tyard, bishop of Chalons, etc. As simply the picture of it has been handed down to our time, nothing of the movement necessary to actuate it is known. Recently

one-half of these are used, the wheel T has in Fig. 2 been sketched as segment, with a division of 26 for the whole circumference.

It results from the preceding that the rack R, moved by the snail S through the intermediary lever-arm H lying upon it, must itself, as well as the wheel T, be propeled 12 teeth farther when the lever H rises from the lowest to the highest point of the snail S.



MYSTIC CLOCK AS A WINDOW SHOW PIECE. FIG. 1

however, a correspondent of the *Deutsche Uhrmacher-Zeitung*, who signs himself W. S., has constructed a movement necessary to produce the motion, and describes it as follows: Fig. 1 is the open face, Fig. 2 the mechanism, connected with a sufficiently strong spring movement with balance.

Let P, Fig. 2, be the front plate of the movement; at *p* is a small prolongation to serve as bearing for the shaft *t*, which opens and closes the fan. The bridge serving as bearing for the front pivot of the shaft *p* is left out in the illustration.

Next, upon the hour pipe is located a snail S, the highest portion of which is controlled by the circumference of the hour wheel, as the former must be a little smaller than the latter, so that it can pass freely on the minute-wheel pinion. Let us next determine the lowest place of the snail in the following manner:

We start from the supposition that the shaft *t*, in order to open the fan, consisting of 13 bars, from a closed condition to a semi-circle, must accomplish  $\frac{1}{2}$  of one-half revolution: this takes place within 12 hours. For the sake of simplicity we also suppose that the pinion or small wheel T, on which a rack R effects the proper motions, must be turned one tooth farther each hour. We therefore obtain 26 as the number of teeth for this wheel T. As only

So as to be able to divide the teeth of the rack upon the wheel cutting machine, it is necessary that for its angular motion be chosen a number of degrees that divide without a remainder in 360° (the periphery of a circle); it is also convenient for the sketching of the mechanism, if the number of the degrees of this angular motion be divisible by 12 (the number of the acting rack teeth). Let us, therefore, try it with an angular motion of 24°, which complies with these two requirements.

The next point of interest is to locate the point of rotation *h* of the rack R and of the lever H in such a manner that a sufficiently high step *s* can be made on the snail (naturally, as far as the diameter of the hour pipe permits it), and that hereby the lever H accomplishes the previously determined angular motion of 24 degrees. So that the tothing of the rack does not become unduly fine—because the teeth have to resist a fairly strong pressure—we shift the rotary point *h* also a little higher up, as has been done in Fig. 2. We now can determine the lowest place of the snail S. We fix it in such a way that the

point of the lever H, lying upon the circumference of the snail, passes from the highest to the lowest point of the snail through a path of 24 degrees.

Having in this manner established the height of the step *s* we can afterwards construct the snail easily by simply letting its circumference, from the lowest point, raise the height of the step *s* one-twelfth for every one-twelfth revolution. Having thereby determined the rotary point of the rack, we ascertain also the depthing distance *ht*; from this we are able to determine the size of the dividing circles for the two toothings of R and T. Under the supposition that this depthing distance amounts to 150 millimeters we go to work as follows:

The rack R must upon 24° of its circumference obtain 12 teeth. As 24 is contained in 360 fifteen times,  $15 \times 12 = 180$  teeth upon the whole circle; that is, the tothing of the rack corresponds to that of a wheel of 180 teeth, while, as already mentioned, for the wheel T 26 teeth come upon the whole circumference. Since, now, in the depthing R T the wheel T may be regarded as pinion, and since the dividing circle of a wheel is proportioned to that of its pinion as the number of teeth of the former to that of the latter, we only need to divide the distance  $ht = 150$  millimeters into two parts, of a ratio of 180:26, to find the radii of the required dividing circles.

This is done in the following way: We add the two proportion numbers 180 and 26, which we will designate with *r* and *t*, and obtain the number 206 for the depthing distance. But since this is really 150 millimeters, we find the two required magnitudes by simple proportion, saying

$$r : 150 = 180 : 206$$

$$t : 150 = 26 : 206$$

From this we obtain the required magnitudes by the following calculations:

$$r = 150 \times 180 : 206 = 131.068 \text{ mm. (radius of the dividing circle of rack R).}$$

$$t = 150 \times 26 : 206 = 18.932 \text{ mm. (radius of the dividing circle of wheel T).}$$

$$\text{Total, } 150.000 \text{ mm.} = \text{depthing distance.}$$

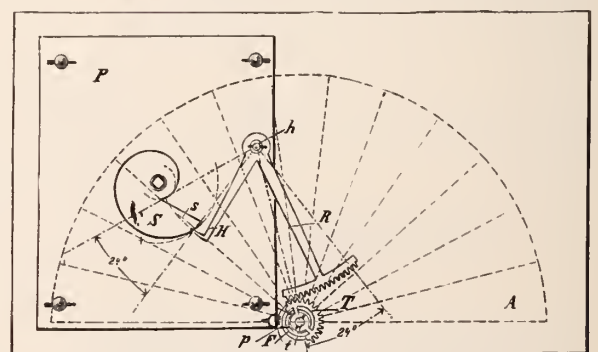

FIG. 2.

Naturally, the depthing distance 150 mm. is merely used to demonstrate, and the true measured distance must be employed.

To find the actual diameter of the two wheels it is only necessary to add to above magnitudes the amount of the rounding height (equal to the breadth of the tooth or



tooth space), which will, in the present case, not only have to be done with the rack R, but also with the wheel T, which is to be regarded as pinion, because this is active in the shutting of the fan as impelling pinion, for which reason it is to be made a little larger than ordinarily.

We calculate, therefore: the operative radius of the wheel, a part of which is represented by the rack R is, according to calculation=131.068 mm., the operative diameter is, therefore,  $2 \times 131.068 = 262.136$  mm. In order to ascertain the breadth of the tooth, we must multiply this diameter by 3.1416 and divide by 360 (number of teeth and tooth spaces). We obtain: Breadth of tooth (height of rounding) =  $\frac{262.136 \times 3.1416}{360} = 2.2875$  mm.

If we add this amount to the radius of the dividing circle of the rack=131.068 mm., we obtain 133.355 mm., or, round,  $133\frac{1}{2}$  mm. as radius, and twice this, therefore, is 267 mm., as diameter for the block from which we have to cut the rack. The fraise employed must measure the ascertained size of tooth (breadth of tooth space) of 2.28 mm.

In the same manner we obtain as diameter for the wheel T:

$2 \times (18.932 + 2.2875) = 42.439$  mm., or, round,  $42\frac{1}{2}$  mm.

After the two toothings have been rounded, the depthing will be faultless. If next we locate on the shaft a suitable strong spring F, the strength of which suffices to shut the fan with a jerk, when the lever H drops from the highest point of the snail S to its lowest, and fastens the central part a, of the first bar A of the fan firmly with the shaft t, Fig. 2, the construction of the mechanism is ended. It will then function as the original did, if the 13 fan bars are united in such a way that in a fully open state they form a true semi-circle. It is obvious that the movement must have sufficient excess of force to overcome the fairly large amount of friction of the lever H on the snail S.

This timepiece is open to the objection that it shows only the hours, and these, even, not always plainly, because at the time of its first construction it was still all-sufficient. As previously stated the time is indicated by the head of the little snake, which is with its tail fastened upon the velvet cushion. As the fan opens but gradually the correct time can be ascertained only when the hour is full. At 8:30 the fan will stand in a position that will be a very indistinct indication of time.

An article for which there will doubtless be a large demand is the Crystal Sperm Chain Lubricant for bicycles, just put on the market by Wm. F. Nye, New Bedford, Mass. This lubricant is made in the form of a solid stick. When in use it is held so that one end comes in contact with the revolving chain which takes up enough of the lubricant to thoroughly oil itself. It affords a clean, convenient and economical method for oiling bicycle chains, a most important point in the case of wheels. The world-wide reputation of the oils of Wm. F. Nye is sufficient guarantee that this new product will be unexcelled for the purpose for which it is intended.

## Queries by Circular Readers.

**NOTE.**—Questions under this department will be answered as promptly as possible. Some queries require careful investigation before a satisfactory answer can be given; hence such answers are often seemingly delayed. THE CIRCULAR desires every jeweler to take advantage of this department.

NEWARK, May 4, 1896.

EDITOR OF THE JEWELERS' CIRCULAR:

Will you kindly inform me where I can get glass balls—such as boys marbles, only of a better quality and of all colors. Also would like to know where I can get long pins such as they use for hat pins—hardened steel or hard pins of any metal that would be the right length.

GEORGE D. HARTMAN.

**ANSWER:**—Real agate marbles are for sale by Rud C. Hahn, 55 Nassau St., New York. Glass marbles, real and imitation agate marbles may be had from Hinrichs & Co., 29 Park Place, New York, and from Robert Foulds, 95 Chambers St., New York. Regarding steel hat pins such as you want, we understand that it is customary for manufacturers to buy from the importers quantities of cheap jet pins, and substitute other heads, the loss of the jet heads being slight. Importers of such articles are A. & H. Veith, 719 Broadway, New York; H. Veit, Son & Co., 622 Broadway, New York; Sullivan, Drew & Co., 600 Broadway, New York. Perhaps the American Pin Co., New York may be able to furnish you what you want.

In response to queries as to the text of the Sterling Silver law recently passed in Rhode Island, we reprint here the measure in full:

**SECTION 1.** Any manufacturer or dealer who makes or sells, or offers to sell or dispose of, or has in his or her possession with intent to sell or dispose of, any article of merchandise marked, stamped or branded with the words "sterling," or "sterling silver," or incased or inclosed in any box, package, cover or wrapper, or other thing in or by which the said article is packed, inclosed or otherwise prepared for sale or disposition, having thereupon any engraving or printed label, stamp, imprint, mark or trademark indicating or denoting by such marking, stamping, branding, engraving or printing that such article is silver or sterling silver, unless 925-1000 of the component parts of the metal of which the said article is manufactured is pure silver, shall be imprisoned not more than six months or fined not more than five hundred dollars for each offence.

**SEC. 2.** Any manufacturer or dealer who makes or sells, or offers to sell or dispose of, or has in his or her possession with intent to sell or dispose of, any article of merchandise marked, stamped or branded with the words "coin" or "coin silver" or incased or inclosed in any box, package, cover or wrapper, or other thing in or by which the said article is packed, inclosed or otherwise prepared for sale or disposition, having thereupon any engraving or printed label, stamp, imprint, mark or trade mark, indicating or denoting by such marking, stamping, branding, engraving or printing that such article is coin or coin silver, unless 900-1000 of the component parts of the metal of which the said article is manufactured is pure silver, shall be imprisoned not more than six months or fined not more than five hundred dollars for each offence.

**SEC. 3.** Any manufacturer or dealer who makes or sells, or offers to sell or dispose of, or has in his or her possession with intent to sell or dispose of, any article of merchandise, whose component parts are made of the same metal soldered together, which article is marked, stamped or branded with the words "sterling" or "sterling silver," unless all of said component parts shall contain not less than 925-1000 parts of pure silver, shall be imprisoned not more than six months or fined not more than five hundred dollars for each offence.

**SEC. 4.** Any manufacturer or dealer who makes or sells, or offers to sell or dispose of, or has in his or her possession with intent to sell or dispose of, any article of merchandise, whose component parts are made of the same metal soldered together, which article is marked, stamped or branded with the words "coin" or "coin silver," unless all of said component parts shall contain not less than 900-1000 parts of pure silver, shall be imprisoned not more than six months or fined not more than five hundred dollars for each offence.

**SEC. 5.** Any manufacturer or dealer who makes or sells, or offers to sell or dispose of, or has in his or her possession with intent to sell or dispose of, any article of merchandise comprised of leather, shell, ivory, pearl, glass, porcelain, pottery, steel or wood, to which is applied or attached a metal mounting marked, stamped or branded with the words "sterling" or "sterling silver"

unless said applied or attached metal mounting shall contain not less than 925-1000 parts of pure silver, shall be imprisoned not more than six months or fined not more than five hundred dollars for each offence.

**SEC. 6.** Any manufacturer or dealer who makes or sells, or offers to sell or dispose of, or has in his or her possession with intent to sell or dispose of, any article of merchandise comprised of leather, shell, ivory, pearl, glass, porcelain, pottery, steel or wood, to which is applied or attached a metal mounting marked, stamped, or branded with the words "coin" or "coin silver," unless said applied or attached metal mounting shall contain not less than 900-1000 parts of pure silver, shall be imprisoned not more than six months or fined not more than five hundred dollar for each offence.

**SEC. 7.** Any manufacturer or dealer who makes or sells or offers to sell or dispose of, or has in his or her possession with intent to sell or dispose of, any article of merchandise comprised of interior works or movements and an exterior case or covering applied or attached thereto marked stamped or branded with the words "sterling" or "sterling silver," unless said case or covering shall contain not less than 925-1000 parts of pure silver, shall be imprisoned not more than six months or fined not more than five hundred dollars for each offence.

**SEC. 8.** Any manufacturer or dealer who makes or sells or offers to sell or dispose of, or has in his or her possession with intent to sell or dispose of, any article of merchandise comprised of interior works or movements and an exterior case or covering applied or attached thereto marked, stamped or branded with the words "coin" or "coin silver," unless said case or covering shall contain not less than 900-1000 parts of pure silver, shall be imprisoned not more than six months or fined not more than five hundred dollars for each offence.

**SEC. 9.** This act shall take effect upon its passage

## Another Black Pearl.

**HENRY NICHOLS**, Riverpoint, R. I., has a black pearl in his possession which he found in a quahaug shell a short time ago and which he thinks may prove as valuable a gem as the one found at Pawtuxet recently and described in these columns a short time since. Mr. Nichols heard of the finding of the Pawtuxet gem and its value, and he decided that he had a find worth taking care of. Previous to that time he had not treasured the little purplish black pebble-like object which he had found in the shell dug from the mud in Apponaug cove, but upon hearing the story of the other find he brought forth his treasure.

A few days ago he called upon a well known Providence jeweler who examined it and gave it as his opinion that the pearl was a valuable one and advised him to submit it to an expert on pearls. The gem is oval in form, about one and one-half inches in circumference, and in color is almost black, with a tinge of purple. To the eye of the connoisseur it may be a beauty and a valuable gem, but its present owner is hardly to be blamed for not knowing he had something valuable in his possession until the story of the fabulous worth of these dusky gems reached his ears.

# FISHING



# TACKLE.

## To Dealers Only.

**SPLIT BAMBOO RODS,**  
From \$10.80 per doz.,  
to \$76.50 each.

**ALL LANCEWOOD RODS,**  
From \$9.90 per doz.,  
to \$3.00 each.

136 page Catalogue Free.  
Send for it.

**ABBEY & IMBRIE,**  
21 VESEY ST.,  
New York.

# A JEWELER'S NECESSITY



— IS THE —

## “TRADE-MARKS OF THE JEWELRY AND KINDRED TRADES.”

Copyright, 1896, by The Jewelers' Circular Pub. Co., 189 Broadway, New York.

For seven months THE JEWELERS' CIRCULAR has had under way a work that will comprise the trade-marks of every branch of the Jewelry, Watch, Clock, Silverware, Silver Plated Ware, Optical Goods, Precious Stone, Art Pottery, Bric-à-brac, Cut Glass and cognate lines of the Jewelry Industry.



The work is now nearing completion. We consider it will be the most valuable book that has ever been issued to the Jewelry trade.

It is a work which the retailer and wholesaler will immediately appreciate.

It will be a book of constant reference, and will be consulted more perhaps than any other book issued to the trade.

It will be a book of daily use.

It will be sold at a figure that will guarantee its rapid distribution.

In addition to illustrations of the various trade-marks and the names and the addresses of the firms to whom they belong, and the class of goods to which they appertain, the work will contain other interesting and valuable information bearing upon the subject of trade-marks.



Those firms who have as yet not sent electrotype, print or drawing of their trade mark or trade-marks are requested to do so at the earliest possible moment.

Members of the Trade, Manufacturers, Wholesalers and Retailers should at once place their orders for

### “TRADE-MARKS OF THE JEWELRY AND KINDRED TRADES.”

\$1 per copy. Bound in Cloth. Payable now or upon delivery of Book. Detach order below and forward to the Jewelers' Circular Publishing Co., 189 Broadway, New York.



#### ADVANCE ORDER BLANK.

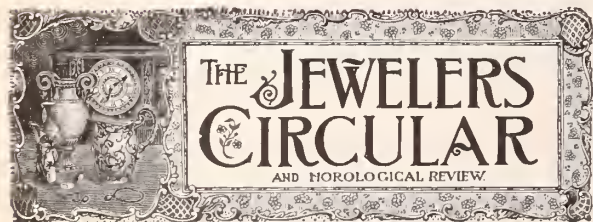

189 Broadway, New York.

..... 1896.

Please file this order for ..... copy of

#### “Trade-Marks of the Jewelry and Kindred Trades”

for which I agree to pay \$1.00 per copy, postage prepaid, upon delivery of book.

Name.....

Street..... City..... State.....

## Workshop Notes.

**Fireproof Cement.**—A very tenacious and fireproof cement for metals is said to be prepared by mixing powdered asbestos with water-glass, to be had in any drug store; it is said to be steam-tight and resist to any temperature.

**To Clean Mercury.**—Strain it through chamois skin, by pressing or squeezing it through the pores two or three ounces at a time. This will be found to be a good way of cleaning mercury of all oxidation and dust, which are all that troubles it generally. But should it have become amalgamated with tin or lead from a dish or cup, the mercury must be passed through the retort.

**Cement for Rubber and Glass.**—For cementing rubber or gutta percha to metal, take pulverized shellac, dissolved in ten times its weight of pure ammonia. In this way the mixture will be of the required consistency. The ammonia penetrates the rubber and enables the shellac to take a firm hold, but as it all evaporates in time, the rubber is immovably fastened to the metal, and neither gas nor water will remove it.

**Olive Green Bronze.**—There are two methods of coloring brass a fine olive green. 1. Dissolve one part of perchloride of iron in two parts of water, and dip the articles therein; you will get a pale or deep olive green, according to the time of immersion. Then wash, dry, and brush. 2. Paint the surface of the brass with a solution of iron and arsenic in nitric acid, polishing with a small quantity of lead glance, and, after heating, coat the whole with a varnish composed of 1 part varnish, 4 parts turmeric, and 1 part gamboge.

**Rapid Silver-plating.**—A well known authority recommended the following: Prepare a powder of three parts of chloride of silver, twenty parts carefully pulverized cream of tartar, and fifteen parts pulverized table salt; mix it into thin paste with water and rub it with blotting paper upon the well cleaned metallic surface. After you are certain that all parts of the article have been touched alike, rub it with very fine chalk powder or dust upon wadding or other soft cloth, wash with clean water, and dry with a cloth.

**Anti-Oxidizer.**—The following is a valuable formula for making an anti-oxidizer for hard soldering, which saves much hard work, the necessity for scouring and rubbing, and an endless amount of polishing afterward. Take five grains of muriate of ammonia, one ounce of soda borax, and one ounce of boracic acid. Dissolve in a small portion of rain water (warm), and keep in a glass bottle. Apply preparation to the article to be soldered with a piece of pegwood. Put the fluid all over article and use any good hard solder. When your solder has flowed dip the article in the cup of pickle. A little brushing, and then it is as bright as ever.

**Good Silver-Plating Solution.**—A person may obtain a good silver-plating solution by dissolving one ounce of cyanide of silver

in 1½ ounces of cyanide of potassium which has previously been dissolved in as little water as possible, then diluting the whole with distilled water to make one quart of solution. This should be placed in a glass vessel—a quart battery jar will answer. Use a strip of sheet silver one or two ounces in weight for an anode, attaching the same by a silver wire. Suspend the cleansed article from copper wire. Two rods of clean brass or copper laid across the top of the jar will serve for making the attachment and the battery connections. This bath will only serve for silvering small articles. For a bath for large articles use cyanide of potassium, 6 ounces; silver (in cyanide), 4 ounces; water, 1 gallon.

**Filing and Tempering Steel Parts.**—The repairer is occasionally compelled to file and temper steel parts for stem winding and repeating mechanisms; for instance, a spring or lever, which on account of their very varying shapes are not to be had in the material stores, so that the repairer must make one or the other himself. A simple method which can also be made use of by workmen of little experience is as follows: The broken spring or complicated steel part is first moistened with soldering fluid and a slight coating of solder supplied. The sheet steel for the raw part is then filed flat for the one side, in the same way moistened with soldering fluid and slightly coated with solder. The former is then laid, well fitted together upon the small piece of sheet steel, and firmly soldered on; the contours are next filed out of the sheet steel with a sharp file, the necessary holes for screws, foot pins, etc., drilled, after which the spring is loosened.

## To Recover Silver from Stonings

THE amount of silver contained in the stonings of large silversmithing establishments is quite an important item, and it is certainly worth while for the foreman or superintendent of such a place to see that the metal is all recovered. The recovery can be effected simply with nitric acid. It is doubtful, however, whether this method is the best and most reliable. Very little on the subject has been published—that is to say, very little that is reliable. It is generally treated, in fact, with a certain degree of superficiality. It is of very little importance to the silversmith to read in random publications that the silver may be recovered from stonings by the use of nitric acid, if it is not stated how much of each shall be taken, or how the silversmith is to go to work to recover the silver. The writer has purposely experimented on the subject, and the following is the result:

The stoning is from time to time taken out of the vessel used for the purpose and passed through a small meshed wire sieve into another vessel which has been half filled with water. By this process the pieces of pumice-stone, coal and blue-stone are strained out. The sediment is left to stand over night in this second vessel, and the next morning the supernatant water is poured off. Some of the lighter black deposit may also pass away. Let it go, as

it contains no silver. If it is Summer the stoning should be set out in the sun to dry; if Winter, it should be dried with artificial heat. When thoroughly dry, it should be red-heated in suitable pans. This process is to be recommended because the mess becomes very much concentrated thereby. Then take for each six pounds of stonings three and one-half pounds of pure nitric acid, of the usual strength. Place the stoning in a large stone or earthen ware vessel, and fill the vessel not more than half full. Pour upon the stonings the indicated weight of nitric acid and cover the vessel.

After twenty-four hours pour in enough hot water to reduce the stonings to a thin paste. Leave the vessel in this condition until the yellow vapors cease to be evolved. When they have stopped pour in more hot water until the vessel is full. When the stoning has deposited again and the water is clear, carefully decant it into another vessel, in which the precipitating with copper will subsequently be performed. Wash the stoning three or four times; in fact, until it contains no trace of silver, which can be recognized if, from time to time, a few grains of salt are thrown into the clear water during the process of washing. After the sediment has deposited, it may be presumed that all the silver has been washed out if the salt dissolves without a white cloud. Pour together the first and second decantings, which contain the largest quantities of silver, and precipitate the latter with copper. It is advisable to take long strips of copper for this purpose, since they are more commodious and can be simply set in the vessel, thus rendering the process of the crystallization of the silver more easily observable. Clean the strips from time to time. If none are at hand, however, take a sheet of copper, perforate it in suitable places, draw a cord through. Tie this to a piece of wood and suspend the plate in the liquor, laying the piece of wood across the vessel.

As was previously said, the first and second decantings contain the greatest amount of silver, which is precipitated with copper, the process being finished in twenty-four hours. The water over the silver must be poured off and the latter washed a few times with warm water. Although the largest quantity of the silver has been obtained in this manner, still the other wash waters also contain a small percentage. But the copper precipitation process would be too slow, and it is best, therefore, to use common table salt. Wash the stoning a few more times with warm water until the few grains of salt thrown in show no cloudiness whatever. Do not hurry the operation. Throw a quantity of salt into the collected washwaters, stir them well, and let them stand for twelve hours. A white deposit chloride of silver, or horn silver, will have become clear. The process may then be regarded as finished. For the sake of satisfying yourself that all the silver has been recovered, throw in a few more grains of salt. If the water remains clear, as well as the stoning, it may be thrown away. The reduction into metallic silver is known to every silversmith.



# New Roy 12 Size Waltham Cases.

Now on the Market.

**S**YMMETRY, STRENGTH, BEAUTY OF FINISH, SWISS HEAD SPRINGS, GOLD DUST BANDS, EXTRA THIN.

These are points of excellence which, as a result of years of experience, we have been able to make the most of, in constructing these splendid cases. They are made for the finer class of trade, only. Leading jobbers handle Roy Solid Gold Cases. Look for this Trade-Mark in every case.



**ROY WATCH CASE CO., 21 Maiden Lane, N. Y.**



## MARINE CHRONOMETERS,

MANUFACTURED BY

**John Bliss & Co., 129 Front St., New York.**

We have on hand a number of Chronometers, by various good makers, not new which have been in service for purposes of navigation, and are excellent instruments. They have been put in perfect repair and will give satisfactory results as to performance. We will sell these Chronometers at low prices, either for cash, or on accommodating terms to suit special cases, or will hire them at moderate rates and allow the hire to apply on purchase.

**SEND FOR CIRCULAR GIVING PRICE & TERMS.**

**NO SOLDER. NO SEAM.**

**SAVE TIME AND MONEY.**

Superior to Anything Ever Shown.  
Apply for Catalogue to

**CHAS. BACHEM, 249-251 N. J. R. R. AVE., NEWARK, N. J.**  
Manufacturer of  
Marquise Heads, Clusters, Ring Shanks, Gypsy Rings, Etc.



# HENRY FERA,

IMPORTER AND CUTTER OF

## DIAMONDS

PRESCOTT BUILDING,  
65 Nassau St. cor. John NEW YORK.  
FACTORY  
60 Fulton St., NEW YORK.

Cutting for the Trade a Specialty,

## ENAMELERS

OF GOLD, SILVER AND PLATED JEWELRY,  
Enameled, Plain and in Colors  
ALSO OF  
**SOCIETY EMBLEMS,  
YACHT AND COLLEGE FLAGS.**  
All Varieties of Painted Enamel Work.

**S. S. WILD & SON,**  
179 Eddy Street, PROVIDENCE, R. I.

Correspondence Solicited.  
Telephone Connection.

## Watchman's Improved Time Detector

12 and 24 Different Keys with  
Safety Lock Attachments.

U. S. Patents 1875-6 and 7. Reissued, 1880  
This Watchman's Time Detector contains all latest improvements. The only perfect instrument in the market. It cannot be tampered with successfully. Warranted in every way

Send for circular  
**E. IMHAUSER, 206 B'way New York U. S. A.**

**J. R. WOOD & SONS,**  
21 & 23 MAIDEN LANE, NEW YORK.

MANUFACTURER OF

**PLAIN SOLID GOLD RINGS.  
SEAMLESS PLAIN SOLID GOLD RINGS.  
ENGRAVED AND CHILD'S RINGS.**

No Ring Stamped Different from Quality.  
Send for Catalogue and Price List.

Old Gold and Silver received and estimated on: if amount allowed does not give satisfaction, notify at once and will return at our expense in same condition as received

**CAMPBELL-METCALF SILVER CO.,  
SILVERSMITHS,**



ALL GOODS 925/1000 FINE.  
Factory, Providence, R. I. Offices, New York and San Francisco.



## The Rambler's Notes.

WHAT THE RAMBLER SAW AND HEARD AMONG THE DEALERS IN ART POTTERY, CUT GLASS, BRONZES ETC.

**CLOCKS FOR FALL TRADE.** THE new lines of French clocks which Bawo & Dotter will show for the Fall trade are now commencing to arrive at the firm's salesrooms, 26-32 Barclay St., New York. In addition to the regular lines of gilt, china, porcelain and bronze clocks and regulators, a larger number of novelties will be shown this year than ever before.

**JARDINIÈRES, FERN POTS, ETC**

FOR the Summer trade, C. L. Dwenger, 35 Park Place, New York, is showing a number of very pretty styles of jardinières, fern pots and flower pots. These goods are in Bonn and German wares with decorations in floral, Delft and other styles. In the line of very large garden pots with pedestals, some new ideas are shown. In one the pedestal, by removing the top, is transformed into a large umbrella stand.

**FRENCH CHINA NOVELTIES.**

THE warerooms of the Empire Cut Glass Co., Para building, Church and Warren Sts., New York, have been increased by the addition of a new room, giving about 50 per cent. more floor space than heretofore. This new department will be devoted to the lines of French china novelties with American decorations, which this company control.

**HANGING PERSIAN LAMPS.**

HANGING Persian lamps for cosy corners, while not an entirely new article to dealers in this country, have become generally in demand but recently and importers of Oriental wares are now for the first time carrying them in large varieties. A. A. Vantine & Co.'s line which is probably the largest in this country is shown in the firm's wholesale warerooms, 18, 20 and 22 E. 18th St., New York. It includes a number of sizes of gilt lamps studded with cut discs of colored glass as well as the regular black brass styles of hanging lamps used in Persia and the Orient.

**GERMAN DELFT NOVELTIES.**

THE line of German Delft pottery and fancy pieces which Hinrichs & Co., 29 Park Place, New York, are now receiving, is the most varied which the firm have yet carried. Novelties, as well as the smaller pieces heretofore common only in French china, now appear in the popular blue decoration. Prominent among these pieces are nut dishes, boudoir sets, biscuit jars, ice dishes and several articles which appear in china for the first time in this market.

THE RAMBLER.

## About Teapots.

HISTORY does not record the name of the original inventor of the teapot, but tradition assigns its birthplace to China and Japan, says a writer in the *New York Sun*. Certain it is that among the earliest spouted and handled utensils of clay that were made in England, many were fashioned after Oriental models. The low cylindrical teapots of "red porcelain," made by the Elers Bros. in Staffordshire, toward the latter part of the seventeenth century, revealed unmistakably an Eastern influence, and this may be said to be true, to a certain extent, of similar vessels produced in all parts of Great Britain for a century afterward.

We are accustomed to think of the Orient as the land of fans and teapots, and numerous collections have been made of Chinese and Japanese patterns. At least two extensive collections of the latter are known to be owned in this country, one of which consists of upward of six hundred specimens, while the other numbers about fourteen hundred designs of almost every conceivable form and character—grotesque, curious, artistic, and ingenious. We are told that in Japan, particularly, teapots abound on every hand, which can be purchased at almost any price, from a few cents to as many dollars.

A naval officer who recently returned from China informed me that he was constantly being importuned by the natives to buy. One day a Chinese vender came aboard the ship with a heavy load of these wares and offered them to the Americans for \$1.50 each. After he had been the rounds without success, the officer, in a spirit of fun, proposed to the merchant to take the lot off his hands for \$2. What was his astonishment when the offer was

promptly accepted, and he found himself the possessor of half a hundred teapots—enough for all his acquaintances, with plenty to spare. And to this day, it is said, he has teapots to give away.

Has any one ever thought of forming a collection of American teapots? I do not know, yet the field is a fertile one and worthy of the attention of any china collector. What is dearer to the feminine heart than the dainty little receptacles for brewing the social beverage? And what is more fascinating than the unearthing of curious old pieces made in this country which we know must be in existence?

The American tea services were imported for a long time before they were manufactured here. Every one is familiar with the old English china of our grandmothers, which included tea caddies and pots of quaint shapes and curious ornamentation—perhaps a "Jackfield," in glossy black, a cauliflower pattern in green, a piece of old Wedgwood in blue and white, a Lowestoft in hard white paste with pink roses, an example of lusted ware resembling burnished silver, or dark blue Staffordshire pottery with printed designs, mayhap with American views. Then there were French, India, Persian, Delft, Dresden, Crown Derby, Spode, Chelsea, and Bristol pieces, but for a long time not a single piece of native American ware, except it might be the commonest earthenware, no record of which has been preserved.

Early in the last century tea began to be used to a considerable extent, and toward the end of the century tea drinking had become general. Not until then do our potters seem to have turned a thought to the manufacture of vessels for use in connection with the Chinese shrub. In 1769 "Tortoise-Shell" and "Green Coler" teapots were made in Boston, as set forth in a newspaper advertisement of the day, but who can identify one of these at the present time? Doubtless some of them survive and are now posing as early English productions with the Whieldon ware which has been found throughout the New England States.

Teapots may also have been produced at the Philadelphia china works about 1772, and probably were, but no examples have yet been brought to light. Soon after the opening of this century, however, several firms in Philadelphia were making them, in imitation of the

**W**  
**A**  
**T**  
**C**  
**H**

GOLD FILLED.

*Lahys* 4K  
MONARCH

**C**  
**A**  
**S**  
**E**  
**S**

ESTABLISHED HALF A CENTURY.

**MARVIN'S**  
FIRE & BURGLAR  
**SAFES**

HAVE MANY PATENTED IMPROVEMENTS  
NOT FOUND IN OTHER MAKES  
THAT WILL WELL REPAY AN INVESTIGATION  
BY THOSE WHO DESIRE TO SECURE  
**THE BEST SAFE**  
MARVIN SAFE CO.

12 PARK PLACE, NEW YORK.

English wares. In 1808 Messrs. Binney & Ronaldson were making red and yellow tea services and two years later black, yellow and red coffee and tea pots were advertised by the Washington pottery in the same city. Even to this day there is an old pottery still in operation in 2d St., where some of the old teapot moulds, used previous to 1820, are yet in existence. By that time various establishments were regularly producing them, particularly the Tucker hard porcelain works in Philadelphia. The patterns were low and graceful and original in design, embellished with rudely painted landscapes in brown.

The presents given to Princess Marguerite d'Orléans on the occasion of her marriage with the Duke de Magenta were extremely varied. The bride received from the Duke d'Aumale an emerald necklace set in an old fashioned style, showing a succession of symmetrical *motifs*, introducing table-cut stones; from the Duke and Duchess d'Acoste an elegant diadem, consisting of large turquoises circled with diamonds; from other aristocratic relations and friends a handsome emerald bracelet, a monogram brooch in brilliants,



Send For New Price List.  
HENRY C. HASKELL,  
11 John St., New York.

a pearl and diamond bracelet, a magnificent pearl necklace of five rows, an artistic jeweled buckle, with the initial M in diamonds, a gold parasol handle set with rubies and diamonds, a painted fan, representing a hunt at Chantilly, etc. The ancient aides-de-camp of the late Marshal MacMahon, the bridegroom's father, presented the young princess with a handsome Louis XVI. table of silver most daintily chased.

**The Handling of Bicycles By Jewelers.**

MONTREAL, Can., May 22.—A new feature in the jewelry business is the selling of bicycles. The irrepressible wheel has even invaded the precincts of gold, silver and precious stones. The first and only jeweler in this city to take up the sale of bicycles as a side issue is A. Mongeau, St. Lawrence St. He is the Montreal agent for the America Bicycle Co., Chicago. Already he has sold four of the "America."

Mr. Mongeau, however, is not altogether optimistic in his views on jewelers selling bicycles. To a CIRCULAR representative he said: "It is hard to sell bicycles for cash. Credit is asked in almost every case and it does not pay us to sell them on credit. Then again, there is too much competition in the business. Not only are there regular bicycle stores in the city, but hardware and gun stores are dealing heavily in them. I keep one bicycle in stock and it is all I have room for. To sell bicycles one must keep a rather large stock on hand."

**S. M. LEWIS & CO.**

SILVER GOODS A SPECIALTY.

37 and 39 MAIDEN LANE, NEW YORK.

**Have Removed**

To the

**LORSCH BUILDING,**

**A. J. COMRIE,**

AUCTIONEER,

22 John St., N. Y.

SPECIAL SALESMAN OF WATCHES, DIAMONDS, BRIC-A-BRAC, FOR ESTABLISHED JEWELERS.

WRITE FOR PARTICULARS

DON'T FORGET THE JEWELERS' CIRCULAR PUBLISHING CO.'S BOOK LIST when in want of any technical book in the Jewelry or Kindred Trades.



**THE QUESTION**

WILL IT TARNISH ? Need

not be asked if your Tissue Paper bears this label.

MANUFACTURED BY

**C. H. Dexter & Sons,**

WINDSOR LOCKS, CONN.

◁ BE SURE YOU GET THIS BRAND ▷

It has been adopted and is now used by the leading manufacturers of this country.

# CARBORUNDUM

THE GREATEST ABRASIVE YET DISCOVERED.

Four times the Labor and Expense-saving qualities of Emery, Corundum or other abrasives. Adapted for Lapidary Work, Grinding, Polishing and every operation where a perfect abrasive is necessary.

Hones, Slabs, Files.

CUT THIS OUT.

**Price List of Carborundum Wheels.**

ACHESON'S PATENT, February 28th, 1893; February 26th, 1895.

DIAM. IN.	THICKNESS IN INCHES.																MAX. REV.
	1/4	3/8	1/2	5/8	3/4	1	1 1/4	1 1/2	1 3/4	2	2 1/4	2 1/2	2 3/4	3	3 1/2	4	
1	\$.15	\$.15	\$.20	\$.20	\$.20	\$.25	\$.30	\$.30	\$.35	\$.40	\$.40	\$.45	\$.50	\$.50	\$.60	\$.70	18000
1 1/2	.20	.25	.25	.25	.30	.30	.35	.40	.40	.45	.50	.55	.55	.60	.70	.75	14000
2	.20	.30	.30	.30	.35	.40	.45	.50	.55	.60	.60	.65	.70	.75	.85	.90	11000
2 1/2	.25	.35	.40	.45	.50	.55	.65	.70	.80	.80	1.00	1.10	1.20	1.25	1.40	1.50	8800
3	.30	.45	.55	.60	.65	.75	.85	1.00	1.15	1.25	1.40	1.50	1.60	1.75	2.00	2.20	7400
3 1/2	.40	.50	.65	.70	.80	1.00	1.15	1.30	1.45	1.65	1.80	1.95	2.10	2.20	2.55	2.90	6300
4	.50	.60	.75	.85	1.00	1.20	1.40	1.60	1.80	2.00	2.20	2.40	2.60	2.80	3.20	3.60	5500
5	.70	.85	.95	1.15	1.25	1.60	1.95	2.30	2.60	3.00	3.30	3.65	3.95	4.25	4.90	5.55	4400
6	.95	1.10	1.30	1.55	1.75	2.20	2.70	3.15	3.60	4.10	4.55	5.00	5.45	5.90	6.80	7.70	3700
7	1.25	1.45	1.65	1.95	2.30	2.95	3.50	4.15	4.80	5.40	6.00	6.60	7.20	7.80	9.00	10.25	3160
8	1.50	1.70	2.00	2.40	2.80	3.60	4.40	5.20	6.00	6.75	7.55	8.30	9.10	9.90	11.45	13.00	2770
9	1.80	2.10	2.40	2.90	3.35	4.30	5.30	6.25	7.25	8.20	9.15	10.10	11.10	12.05	14.00	15.90	2460
10	2.15	2.50	2.85	3.45	4.00	5.15	6.30	7.45	8.60	9.75	10.90	12.00	13.20	14.35	16.60	18.90	2210
12	2.65	3.10	3.70	4.50	5.25	6.80	8.40	9.95	11.50	13.05	14.60	16.20	17.75	19.30	22.45	25.50	1850
14			5.05	6.05	7.00	9.00	11.00	13.00	15.00	16.95	18.95	20.95	22.95	24.90	28.90	32.80	1580
16					9.10	11.70	14.30	16.85	19.95	22.00	24.55	27.15	29.70	32.30	37.40	42.50	1380
18					11.25	14.45	17.70	21.09	24.25	27.50	30.75	34.00	37.25	40.50	47.00	53.50	1230
20						17.50	21.55	25.55	29.60	33.70	37.80	41.90	45.95	50.00	58.00	66.00	1100

The wheels are made with a vitrified bond and pressed under hydraulic pressure. Those over three inches in diameter are turned up after firing. The same numbers are used to designate the degrees of fineness, as are used with Emery, and the wheels are made in seven degrees of hardness, marked SSS, SS, S, M, H, HH, HHH, from extremely soft to extremely hard. In ordering, state diameter, thickness, hole, number and hardness.

## THE CARBORUNDUM CO.

WORKS: MONONGAHELA, PA., AND NIAGARA FALLS, N. Y.

### THE SWAN FOUNTAIN PEN

Reputation World Wide.  
Made upon Distinct Principles.  
Is a Compressed Air Pump.  
Simply Wet the Insides to Provoke  
an Energy.

W. W. Stewart, Inventor and Patentee.

A variety of Styles and Prices

- 3 Sizes Safety Swans.
- 3 Sizes Self-filling Swans.
- 3 Sizes Adjustable Swans.

MABIE, TODD & BARD,  
NEW YORK AND LONDON.

## AMERICAN WATCH TOOL CO.

ESTABLISHED 1872.  
INCORPORATED 1894.

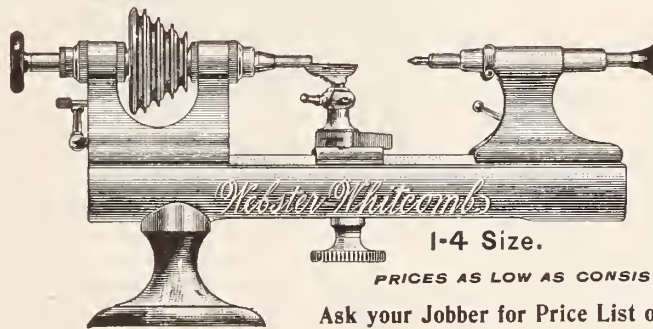

THE  
**Webster-Whitcomb**

1-4 Size.

GROWS IN POPULARITY

PRICES AS LOW AS CONSISTENT WITH QUALITY.

Ask your Jobber for Price List of 1895, or write to us at

Stoney-Batter Works, Chymistry Dist., Waltham, Mass.

### AIKIN, LAMBERT & CO.,

MANUFACTURERS OF

FINE GOLD PENS, HOLDERS, PENCILS,  
TOOTH PICKS, and NOVELTIES.

PAUL E. WIRT FOUNTAIN PENS, at new and lower prices . . .  
MERCANTILE FOUNTAIN PENS, guaranteed to give satisfaction.

Catalogues with terms and discounts furnished to the trade.

BRANCH, 103 STATE STREET, - - - CHICAGO.

### AIKIN-LAMBERT JEWELRY CO.,

IMPORTERS OF

**DIAMONDS.**

JOBBER IN

WATCHES, JEWELRY, CHAINS  
NOVELTIES, ETC.

LATEST DESIGNS.

LOWEST PRICES

19 MAIDEN LANE, NEW YORK.

**CYCLING PROGRESS  
EXEMPLIFIED.**

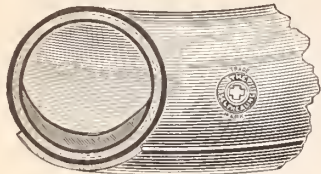

**THE WONDERFUL  
SELF-HEALING TIRES**

are single tube, finest rubber, finest wave Sea Island cotton fibre, re-enforced inside and outside on tread, and no better tire can possibly be made. They are fully guaranteed against all climatic changes, are the most resilient ever made, and when punctured instantly heal the wound of their own volition.

THEY WEIGH NO MORE THAN OTHERS,  
COST NO MORE,  
AND ARE WORTH TEN TIMES MORE.  
—SEND FOR TIRE BOOKLET.—

**W. M. H. CAHN, GENERAL MANAGER,**  
48 and 50 Maiden Lane, New York.

**BY EVERY TEST THEY ARE THE BEST.  
THE UNIVERSAL FAVORITES.**



**SUPERB  
Olympic  
BICYCLES**

For sale by more than 2,000  
Jewelers, and constructed to meet  
the demand for finest quality.

For Adults and Juveniles.

**SEND FOR EXQUISITE  
CATALOGUE.**

Top Grade "Olympics" have SELF-  
HEALING TIRES.

Olympic Cycle Mfg. Co.,  
N. Y. Office: 35 LIBERTY STREET.

**General Jobbing Ag'ts, S. F. MYERS & CO.,**  
WHOLESALE JEWELERS, Myer's Building, New York.

**RECEIVER'S SALE!  
TRADE OPPORTUNITY.**

Entire Stock of

**CHAS. JACQUES CLOCK CO.,**

22 Cortlandt St., New York,

**...Must Be Closed Out...**

**Latest Paris Novelties,  
all New Importations  
of this Spring**

Together with **LARGE STOCK** of

**ELLIOT CHIME CLOCKS,**

And a Fine Line of Other

**HALL CLOCKS.**

By order of

**ALBERT C. WALL, Esq.,**

Receiver.

**BAWO & DOTTER,**

26-32 BARCLAY ST.

NEW YORK.

P. O. Box 1872.



**NO LARGER STOCK  
OF**

**HALL  
CLOCKS**

IS SHOWN IN  
THIS CITY.

Large Stock  
OF  
**MOVEMENTS.**

**NEW DESIGNS  
IN CASES.**

**STERLING**

Sheet and Wire Supplied. All Sizes.

**J. SCHAWEL & CO.,**

Gold, Silver and Platinum Refiners,

29 JOHN STREET, NEW YORK.

**PHILIP BISSINGER & CO.,**

IMPORTERS OF

**PRECIOUS STONES, PEARLS, CORALS and GARNETS,**

ANNOUNCE THEIR

**REMOVAL**

FROM 22 TO

20 JOHN ST., N. Y.



**34 YEARS OF  
HONEST RETURNS**

IS OUR GUARANTEE OF SATISFACTION  
TO ALL OUR CUSTOMERS.

**WE DO OUR OWN SMELTING,**

**JOHN AUSTIN & SON,**

ASSAYERS, REFINERS AND SMELTERS,

74 & 76 Clifford St., Providence, R. I.

**SECURITY PIN GUARD**

PAT'D DEC. 25, 1894  
MANFD BY SECURITY MFG CO. **25¢**

7 ASTOR HOUSE (BROADWAY) N.Y.

85c. doz. Net Cash Discount to Jobbers

**JACOT & SON,**

Importers and Manufacturers of

**Musical Boxes,**

39 Union Square. New York.

**EMMONS  
ASSOCIATED LAW OFFICES.**

PORTLAND, SEATTLE, TACOMA,  
Oregon. Wash. Wash.

Foreign Business a Specialty.

**QUICK SELLERS.....**

IN STERLING SILVER  
ARE MADE BY

**CODDING BROS. & HEILBORN,**

North Attleboro, Mass.

**DUBOIS WATCH CASE CO.**



**FINE HAND MADE  
SOLID GOLD CASES.**

A PRIDE TO THE MAKER,  
DEALER & WEARER.

**X RAYS**

are not needed to see the Xtraordinary merit of the Royal Clusters. The most Xacting Xaminer can find no fault with the Royal Cluster. It is Xactly what your customer has wanted for years. It is a mounting of Xceptional merit, finished with Xtreme care and Xactness.

**HENRY E. OPPENHEIMER & CO., 14 MAIDEN LANE, NEW YORK.**

**DIAMONDS** Importers and Cutters. **L. & M. KAHN & CO.,** 172 Broadway, Cor. Maiden Lane, N. Y., **DIAMONDS**





Copyright by THE JEWELERS' CIRCULAR PUB. CO.

189 Broadway, New York.

Entered at the Post Office in N. Y. as second-class matte

VOL. XXXII.

NEW YORK, WEDNESDAY, JUNE 10, 1896.

NO. 49.

THE LOVING CUP AS AN ART PRODUCT IN SILVERSMITHING.

UPON the seventieth birthday of S. S. Packard, the head of Packard's Business College, New York, which was celebrated at Delmonico's, April 28 last, a beautiful silver loving cup was presented to him by his friends and former pupils located all over the United States, as a testimonial of love and respect.

Wager Swayne, A. Corbin, Jr., and Dr. J. Stedman Converse. Two views of the cup which was designed and made by the Whiting Mfg. Co., 18th St. and Broadway, New York, are here presented. The cup is 15 inches high and has three handles which are decorated with representations of

life. On the base portion of the testimonial are three ornamental panels, as follows: The first shows the birthplace of Mr. Packard, the second, the entrance of the Packard Business College, and the third a scene in the counting room. The three principal panels, located on the main body and between the handles, are



THE PACKARD TESTIMONIAL.—DESIGNED AND MADE BY THE WHITING MFG. CO.

Among the names of the gentlemen and ladies who sat down to the banquet were those of Mayor and Mrs. Strong, C. F. Wingate, Col. Charles E. Sprague, Frank R. Lawrence, president of the Lotos Club, Gen. Horace Porter, Mr. and Mrs. Bronson Howard, Daniel Frohman, Dr. Thomas Hunter, Gen. and Mrs.

ivy and the leaves and the nuts of the horse-chestnut or buckeye, commemorative of Mr. Packard's early life in Ohio. On the body of the cup, above and back of the handles, are in low relief the seals of the three States, Massachusetts, Ohio and New York, where Mr. Packard passed the greater part of his

highly ornamental and interesting. The first shows an excellent portrait in low relief of Mr. Packard, surrounded by palms, laurels, books, etc.; the second displays a group symbolizing education, while in the third is etched the presentation inscription: "Presented to S. S. Packard, Founder and Presi-

# OUR DRESDENE BELTS ARE THE LATEST FAD.

**BELTS IN  
LEATHER AND SILK  
WEBBING.**



**SIDE COMBS  
MOUNTED IN  
STERLING SILVER  
WITH STONES.**

NEW YORK OFFICE:  
21 & 23 MAIDEN LANE.

FACTORY:  
PROVIDENCE, R. I. 403

BOSTON OFFICE:  
WASHINGTON ST.

## OUR GOODS

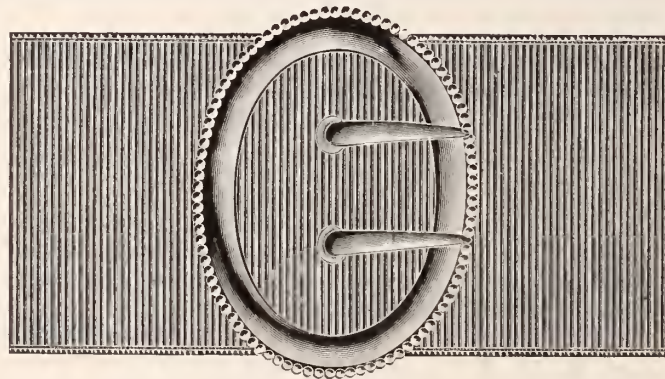

## THE BEST.

# KENT & STANLEY CO., LTD.



SLOAN & COMPANY,  
SUCCEEDING  
JOHN A. RILEY & SLOAN CO.,  
MANUFACTURING JEWELERS,  
23 MAIDEN LANE, N. Y.  
HAYS BUILDING.

AUGUSTUS K. SLOAN, Pres.  
FRANK T. SLOAN, Vice-Pres.

BENNET OSBORN, JR., Treas.  
ALLAN A. McDONALD, Sec'y.

**QUICK SELLERS.....**  
IN STERLING SILVER  
ARE MADE BY  
**CODDING BROS. & HEILBORN,**  
North Attleboro, Mass.

SEND FOR CATALOGUE of books for  
the jewelry and kindred trades. Just  
issued. JEWELERS' CIRCULAR PUB. CO.,  
189 B'way, N. Y.

## “Apparel oft proclaims the man.”



So with our fine note papers, envelopes and papeteries—all our bands, boxes and labels are neat, tasty and artistic and perfectly in keeping with and a credit to the high grade goods with which they are used. Our fashionable stationery is put up in a manner that appeals to people of refined tastes, and it is a line particularly adapted for jewelers. We **do not** sell to dry-goods or department stores. Write for samples.

**PARSONS & GREENE Co.,**  
MANUFACTURING STATIONERS,  
HOLYOKE, MASS.



**New Roy 12 Size  
Waltham Cases.  
Now on the Market.**

**S**YMMETRY, STRENGTH, BEAUTY OF FINISH, SWISS HEAD SPRINGS, GOLD DUST BANDS, EXTRA THIN.



These are points of excellence which, as a result of years of experience, we have been able to make the most of, in constructing these splendid cases. They are made for the finer class of trade, only. Leading jobbers handle Roy Solid Gold Cases. Look for this Trade-Mark in every case.



**ROY WATCH CASE CO., 21 Maiden Lane. N. Y.**

**Buy  
"The Best"**

THE  
**"Dueber  
Special"**  
BICYCLE.

MAYSVILLE, KY., April 24, 1896.

Dueber Watch Case Mfg. Co., Canton, O.

Dear Sirs: The wheel came all right, and in fact exceeds my expectations. I have ridden the different high grade wheels for twenty years, and find this the easiest running wheel I have ever been on. Yours,

JOHN BALLENGER.

CHICAGO, ILL., April 23, 1896.

Dueber Watch Works, Canton, O.

Gentlemen: After a careful and critical examination of the "Dueber Special" Bicycle, I have no hesitancy in recommending it as a first-class wheel in every respect and I consider it the best wheel I have ever seen. The extreme care bestowed upon the fitting and finish of all parts, will alone recommend it to the watch making fraternity, who as a rule, are critical in these respects. The "Dueber Special" ranks with, if it does not surpass the highest grade wheels on the market. I see no reason why it should not have an enormous sale.

Very respectfully,

GEO. K. HAZLITT.



**Standard  
Sterling  
Silver  
Goods.**

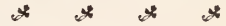

**Belts,**  
LEATHER, GILT,  
SILVER AND  
SILK WEBBING.

**Waist Sets,  
Sleeve Links,  
Hat Pins,**  
IN  
**Sterling Silver**  
AND  
**Rolled Gold Plate.**

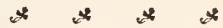

**600 Useful Articles**  
IN  
**Sterling Silver.**



**Foster & Bailey,**  
Providence, R. I.

NEW YORK, CHICAGO,  
SAMPLES ONLY. SAMPLES ONLY.

## Intrinsic merit

combined with low prices, makes Cahoone's line for the coming season the most attractive ever offered to the trade.



## Cahoone's rings

this year are shown in a host of beautiful designs. Particular attention is called to the Imitation Rose Diamond and Opal Combination Rings. Sold by all leading jobbers.

GEO. H. CAHOONE & CO., Kent & Stanley Building, Providence, R. I.  
N. Y. OFFICE, 21 MAIDEN LANE.



A DULL TIME like the present, sets us all at work to improve our goods.

WE have made a special study of One Piece Pin Stems, Joints, Catches, etc., and are furnishing these findings to manufacturers in gold, sterling silver, and other metals

These are acknowledged to be the best made. This sounds big. It is. Will you allow us to demonstrate it to you?

B. A. BALLOU & CO.,  
61 Peck Street,  
Providence, R. I.



of the Best Quality, which are offered to Jewelers of recognized standing only.

Trade Mark 'SILVER WHITE,' registered.

## The STATIONERS' ENGRAVING CO.,

98 TO 102 NASSAU STREET, NEW YORK.

MAKERS OF

WEDDING INVITATIONS, RECEPTION AND VISITING CARDS

ESTABLISHED 1849.

INCORPORATED 1890.

## J. BRIGGS & SONS CO.,

MANUFACTURERS OF

### Gold and Silver Plate and Seamless Wire,

65 CLIFFORD STREET, PROVIDENCE, R. I.

dent of Packard's Business College, New York, on his seventieth birthday, by his pupils, friends and co-workers throughout America, in grateful recognition of his distinguished service in the cause of business education. An educator who inspires in youth high ideals, quickens thought and builds up others into noble manhood and womanhood, benefits humanity and honors God."

Above the picture of the birthplace is the date 1826, and above the portrait, 1896, the figures being applied. The main decorative work is in chasing, there being no repoussé. Perhaps the most artistic feature is the modeling in low relief of the medalion which shows a perfect lifelike portrait of the recipient of the cup. The wreaths of laurel, the ivy and the books and educational insignia are applied. Two of the large panels are modeled in low relief, while the pictures in the small panels at the base are etched work, the inscription panel being partly etched and partly applied. The seals are in low relief modeling. The form of the cup is original while the treatment of the handles, projecting as they do from the body and uniting homogeneously with the base, is entirely new and effective. In its entirety the Packard cup is an emblem of education, an epitome of the life of a noted and respected man, and an expression of the higher possibilities of silversmithing. It is fully worthy of all the praise it has elicited.

### The Swiss Watch Industry Said to be Booming.

WALTHAM, Mass., June 5.—Paul Simon, who has been acting as foreign agent for the American Watch Tool Co., arrived in Waltham, last week. Mr. Simon said in an interview that the Swiss watch factories are running to their fullest capacity, one factory which turns out 2,500 watches a day, being 80,000 behind in orders. He further stated that all through Switzerland up-to-date machinery is being introduced in all the watch factories, they following, as closely as possible, in the line of improvements in machinery, the big American factories, and producing watches so cheaply that they sell all over Europe so readily, that there is not a company in Switzerland of any importance that can keep up with orders.

### A Smuggling Enterprise Suspected on the Pacific Coast.

SAN FRANCISCO, Cal., May 30.—Local diamond dealers are excited over information concerning the doings of one Solomon, a resident of Amsterdam and a dealer in diamonds. Solomon came from Central America a few days ago on the same steamer that brought Gen. Barillas, and it is said that he sold the General \$5,000 worth of mounted goods. The rumor is also that he succeeded in smuggling them.

WE MAKE



STOCK FOR

CANE HEADS,  
UMBRELLA MOUNTINGS  
PENCIL-CASES,  
WATCH-CASES,  
WATCH-CROWNS,  
THIMBLES,  
SPECTACLE AND  
EYE-GLASS BOWS,  
DIAMOND MOUNTINGS,  
&c., &c., &c.

# TWO NEW PIECES FOR

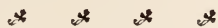

Where would we be if in a quiet season we decided to make **nothing new** till we saw a **demand**?

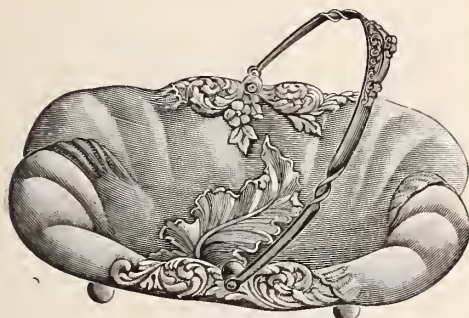

No. 6607. BON-BON DISH.



No. 2846. HAND MIRROR.

# EVERY DAY IN THE YEAR.

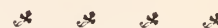

Make the **demand**. Sort up your stock with 25, 50 or 100 new pieces that will make people buy. We furnish goods that sell.



No. 1969. TRINKET TRAY.

FACTORIES,  
NEW BEDFORD, MASS.

SALESROOMS,  
NEW YORK. CHICAGO.  
SAN FRANCISCO. MONTREAL.

## PAIRPOINT MFG. COMPANY.

# CARBORUNDUM

THE GREATEST ABRASIVE YET DISCOVERED.

Four times the Labor and Expense-saving qualities of Emery, Corundum or other abrasives. Adapted for Lapidary Work, Grinding, Polishing and every operation where a perfect abrasive is necessary.

### Price List of Carborundum Wheels.

ACHESON'S PATENT, February 26th, 1893; February 26th, 1895.

DIAM. IN.	THICKNESS IN INCHES.															MAX. REV.	
	1/8	3/8	1/2	5/8	3/4	1	1 1/4	1 1/2	1 3/4	2	2 1/4	2 1/2	2 3/4	3	3 1/2		4
1	\$.15	\$.15	\$.20	\$.20	\$.20	\$.25	\$.30	\$.30	\$.35	\$.40	\$.40	\$.45	\$.50	\$.50	\$.60	\$.70	18000
1 1/2	.20	.25	.25	.25	.30	.30	.35	.40	.40	.45	.50	.55	.60	.60	.70	.75	14000
2	.25	.30	.30	.30	.35	.40	.45	.50	.55	.60	.60	.65	.70	.75	.85	.90	11000
2 1/2	.25	.35	.40	.45	.50	.55	.65	.70	.80	.90	1.00	1.10	1.20	1.25	1.40	1.50	8000
3	.30	.45	.55	.60	.65	.75	.85	1.00	1.15	1.25	1.40	1.50	1.60	1.75	2.00	2.20	7400
3 1/2	.40	.50	.65	.70	.80	1.00	1.15	1.30	1.45	1.65	1.80	1.95	2.10	2.20	2.55	2.90	6300
4	.50	.60	.75	.85	1.00	1.20	1.40	1.60	1.80	2.00	2.20	2.40	2.60	2.80	3.20	3.60	5500
5	.70	.85	.95	1.15	1.25	1.60	1.95	2.30	2.60	3.00	3.30	3.65	3.95	4.25	4.90	5.55	4400
6	.95	1.10	1.30	1.55	1.75	2.20	2.70	3.15	3.60	4.10	4.55	5.00	5.45	5.90	6.80	7.70	3700
7	1.25	1.45	1.65	1.95	2.30	2.95	3.50	4.15	4.80	5.40	6.00	6.60	7.20	7.80	9.00	10.25	3160
8	1.50	1.70	2.00	2.40	2.80	3.60	4.40	5.20	6.00	6.75	7.55	8.30	9.10	9.90	11.45	13.00	2770
9	1.80	2.10	2.40	2.90	3.35	4.30	5.30	6.25	7.25	8.20	9.15	10.10	11.10	12.05	14.00	15.90	2460
10	2.15	2.50	2.85	3.45	4.00	5.15	6.30	7.45	8.60	9.75	10.90	12.00	13.20	14.35	16.60	18.90	2210
12	2.65	3.10	3.70	4.50	5.25	6.80	8.40	9.95	11.50	13.05	14.60	16.20	17.75	19.30	22.45	25.50	1850
14			5.05	6.05	7.00	9.00	11.00	13.00	15.00	16.95	18.95	20.95	22.95	24.90	28.90	32.80	1580
16					9.10	11.70	14.30	16.85	19.95	22.00	24.55	27.15	29.70	32.30	37.40	42.50	1380
18					14.45	17.70	21.00	24.25	27.50	30.75	34.00	37.25	40.50	47.00	53.50	1230	
20					17.50	21.55	25.55	29.60	33.70	37.80	41.90	45.95	50.00	55.00	66.00	1100	

The wheels are made with a vitrified bond and pressed under hydraulic pressure. Those over three inches in diameter are turned up after firing. The same numbers are used to designate the degrees of fineness, as are used with Emery, and the wheels are made in seven degrees of hardness, marked SSS, SS, S, M, H, HH, HHH, from extremely soft to extremely hard. In ordering, state diameter, thickness, hole, number and hardness.

Hones, Slabs, Files.

CUT THIS OUT.

## THE CARBORUNDUM CO.

WORKS: MONONGAHELA, PA., AND NIAGARA FALLS, N. Y.

TARIFF DECISIONS AND CUSTOMS RULINGS.

Reported from Washington expressly to The Jewelers' Circular.

**Duty on Clock Springs and Pins.**

THE protest filed some time since with the General Appraisers by J. C. Metzger & Co. as to the correct classification for duty of certain springs and pins to be used in clocks, under paragraph 173. of the Act of Aug. 28, 1894, which provides for "watches and clocks, and parts thereof, whether separately packed or otherwise, twenty-five per centum ad valorem," has been affirmed, and the decision of the Collector of the port of New York to the contrary has been overruled.

**Hair Pins not Always Jewelry.**

THE Board of General Appraisers have decided that hair pins, even when they are ornamented with fancy heads, are not always to be classed as jewelry. This was evidenced by a decision rendered in the appeal entered by H. Wolf & Co. from an appraisalment made by the Collector of the port of Chicago, by which they were classed under paragraph 336 of the Act of Aug. 28, 1894, as "Jewelry: All articles not specially provided for in this Act, commercially known as 'jewelry,' \* \* \* thirty-five per centum ad valorem." The articles in question were hair

pins composed of metal and glass, with metal as the component material of chief value. The only way in which they differ from the ordinary two-prong hairpin of commerce is that they have attached to the upper part thereof ornaments composed of metal and glass beads, or ornaments which bear some resemblance to precious stones. They are inexpensive, and are neither composed of precious metals nor plated with gold or silver. It was the opinion of the Board that they are not known commercially as "jewelry," and they therefore sustained the claim of the appellants that the articles should have been classified under paragraph 170 of the same Act, which provides for "pins, metallic, including pins with solid or glass heads, hair pins, safety-pins, and hat, bonnet, shawl, and belt pins, not known commercially as jewelry, twenty-five per centum ad valorem"; thus reversing the Collector's decision.

**Clocks for the Treasury Department.**

WASHINGTON, D. C., June 5.—Bids were opened in the office of the superintendent of the Treasury, on June 1st, for supplying eight-day, pendulum wall clocks, with 12-inch dials, of standard make, and electric or synchronizing systems of clocks for United States

public buildings under the control of the Treasury Department, east of the Rocky Mountains. The bidders were as follows:

Eastman Clock Co., Boston, Mass., 12-inch dials, \$10.50 each; 14-inch dials, \$12.69 each.

Seth Thomas Clock Co., New York, regulator No. 2, \$10.45 each.

E. Howard Watch & Clock Co., New York, 12-inch dials, \$12 each.

Owen-Thompson Electric Co., Chicago, Ill., No. 4 master clocks, \$50 each; No. 3 master clocks, \$75 each; secondary clocks, \$22.50 each.

E. Howard Watch & Clock Co., No. 89 master clocks, \$50 each; secondary clocks, \$30 each.

**Manager Dunning a Fugitive from Justice.**

COLUMBUS, O., June 4.—E. M. Blauvelt, the N. High St. jeweler, is anxious to locate W. D. Dunning, formerly a salesman in his employ. Dunning has been employed by Blauvelt for the past six months as manager of the Home Co-operative Watch Co., a concern selling watches and rings in clubs of 40 or 50. Dunning carried several samples with him and canvassed the city getting up these clubs. Recently Blauvelt discovered that some of the contracts turned in by Dunning were forged, and he at once sent for Dunning to come to the store. He came, and attempted to explain, but finally agreed that if nothing was done about the matter he would bring his samples to Mr. Blauvelt and settle up all shortages.

We call the attention of the Jewelry Trade to our new line of

ROCOCO BELT

FOR EITHER SILK OR

BUCKLES

LEATHER BELTING.

- 8678 OLD GOLD.
- 8679 OXIDIZED.
- 8683 OLD GOLD, ENAMELED.
- 8752 OXIDIZED, ENAMELED.

When ordering, state whether Leather or Silk Belting is desired.

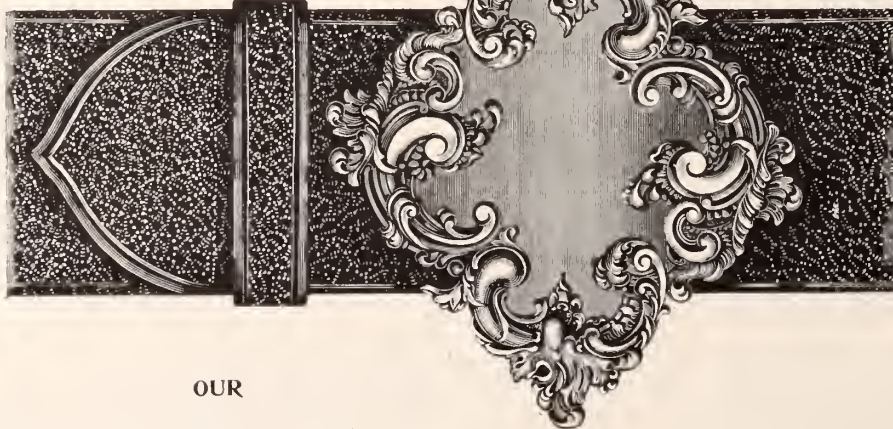

THE DIE WORK, DESIGN AND FINISH OF THESE GOODS ARE OF THE HIGHEST ORDER.

OUR

LORRAINE BELT RETAINER

(Patent applied for.)

Is the simplest and most practical Belt Retainer in the market, and is equally satisfactory for Leather or Silk Belting.



FRONT VIEW.

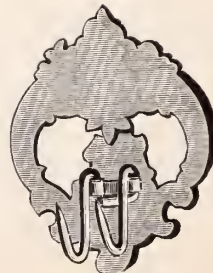

BACK VIEW.

BIPPART & CO.

MANUFACTURING JEWELERS,

NEWARK, N. J.

**Awards in Jewelry Designing, by the N. E. Manufacturing Jewelers' Association.**

PROVIDENCE, R. I., May 29.—At the regular Winter reunion of the New England Manufacturing Jewelers' Association, held last February, a very interesting address was delivered by

Shortly after the reunion this committee met and decided that the appropriation should be divided into three prizes and also that the design for the article of jewelry should be in the form of a two-inch brooch. The conditions of the competition were to be as follows :

and in originality of conception and execution was one of the finest seen in this city for a long time and offers a new thought for jewelers' samples. It is in the form of a wreath of leaves in the centre of which suspends a bangle. The brooch is finished in Roman gold and enamel; at intervals among the leaves pansies are intermingled, while at the bottom is a cherub's head and wings. Several different designs of bangles accompanied this design.

The second and third prizes were also awarded to Mr. Brant. The former is an oval oxidized silver frame for a miniature or cameo. In general design the rococo pattern is followed, and into this a frame has been artistically interwoven. The third is for a miniature brooch, consisting of a foliated scroll frame, having upon each quarter of the circle a cluster of three whole pearls. The leaves in which these scrolls terminate are of bright gold and relieved by flowers of enamel. Inside of this frame is a fine circle of ball beads encircling the miniature.

Having exhausted the awards the committee, who were assisted by President Fanning and other members of the Association, proceeded to select some of the more meritorious for honorable mention. There decisions were as follows:

First.—An Egyptian lotus and asp in gold and green, by Miss Mabel Wootward. This consisted of two branches of lotus, each having three flowers, the stems terminating in a scroll. These met in the center and were tied together by the folds of the serpent, which had coiled about them.

Second.—A conventional design of knife edge wire and groupings of stones. In the drawing turquoises are represented, placed in the form of a cross, with delicate gold ornamentation. This was by Miss Alberta Achorn.

Third.—This is a beautiful thing and many wonder that it was not selected as the recipient of the first prize. It is attractive and clear in its force of design, and impressed the committee very favorably, but for some reason did not come up to the requirements that they had individually formed. It is probable that its rejection was its impracticability for jewelry purposes. Miss Frances Henley is the artist, and she has certainly wrought out a handsome and striking piece of work. It is of the Delft style that has fast regained popularity. The setting is composed of gold and blue enamel, in perfect keeping with the theme in the center—a Holland landscape. There is great strength displayed; the design is odd, and could be adapted to high class and expensive work only.

Miss Anna Phillips' design was the fourth mentioned. It is of radial scrolls, similar somewhat to numerous other knife-edge patterns commonly found in the jewelers' samples. It is very neat, but not strikingly original.

The fifth is a frame for a marine view to be executed in enamel or ivory painting. A line of pearls ornament the upper portion of the frame. This was designed by F. M. Davol.

Sixth—Another of Miss Francis Henley's designs, and well adapted for jewelers' purposes of a high class, is a round miniature brooch in the form of a graceful frame, beautiful interlaced scrolls being the prevalent feature.

Seventh—A small brooch of simple design, the center of which is an opal surrounded by pearls, and these by eight scrolls with rubies and other stones on the outer edge and between the scrolls. Miss Alma Field was the designer.

The new cracker jars are immense in size. A novelty in this direction is of green glass overlaid with silver in ornate patterns.



Warren S. Locke, principal of the Rhode Island School of Design, in the course of which he dilated upon the advantages which might be gained by the manufacturing jewelers of this vicinity should they seek for designs from the school. President Joseph H. Fanning further commented upon this thought, and suggested the appropriation of \$25 to be used in awards for competitive designs. This appropriation was voted, and the matter of details and award was left in the hands of the executive committee, consisting of John M. Buffinton, Frank T. Pearce, and Samuel E. Fisher.

First, adherence to the style of design chosen; second, originality displayed; third, artistic execution. Principal Locke and the students immediately displayed a great interest in the matter and as a result 42 designs from which to make the awards were sent to the committee. This large number was very surprising to the committee, and more so when they came to examine them. All were well executed and worthy of favorable comment and the committee found much difficulty in making their selections.

The first prize design was by John S. Brant

# IMPORTANT.

## The United States Circuit Court of Appeals

has decided that the Colby patent for pendant setting Watch Cases is invalid, and from this decision there is no appeal.

We are, therefore, the only manufacturers and ours the only valid pendant set device used in the manufacture of pendant setting Watch Cases.

In answer to some inquiries made of us, we wish to say we do not manufacture a pendant setting Watch Case for the new model 16 size Elgin Watch movement.

**The Dueber Watch Case Mfg. Co.,**  
CANTON, OHIO.

## AMERICAN WATCH TOOL CO.

ESTABLISHED 1872.  
INCORPORATED 1894.



THE  
**Webster-Whitcomb**

GROWS IN POPULARITY

PRICES AS LOW AS CONSISTENT WITH QUALITY.

Ask your Jobber for Price List of 1895, or write to us at

**Stoney-Batter Works, Chymistry Dist., Waltham, Mass.**

A Western customer writes under date of March 25, 1896: "The time for making Class Pins is approaching and we have had several calls this week. Please send us circular of your very *Latest Designs* in *Class Rings* and quote prices and we will make an effort to get some orders."

Requests for "up-to-date" Designs *promptly* sent to Jewelers with estimates.

**Henry C. Haskell,**

**MAKER,**

**11 John St., New York.**

**A. J. COMRIE,**

**AUCTIONEER,**

**22 John St., N. Y.**

**SPECIAL SALESMAN OF WATCHES, DIAMONDS,  
BRIC-A-BRAC, FOR ESTABLISHED JEWELERS.**

WRITE FOR PARTICULARS



**V**

Means everything that is first quality in Watch Glasses.

**T**

They are used by more Watch and case makers than all others.

**F**

Their success has induced others to copy the label but not the quality.



**Early Summer Fashions in Jewelry and Silver.**

**A LADY'S RAMBLES AMONG THE JEWELERS.**

A new idea for the bicycle girl is a silver bicycle chain with lock, for locking of the wheel.

\*

A charming example of corsage ornament is composed of two rosettes of pearls and diamonds linked with ropes of pearls.

\*

Tortoise-shell furnishings for the writing table are gaining in popularity.

\*

The assortment of semi-precious jewelry offered unusual attractions, notably in necklaces, in which the hues of garnet and aquamarine, of topaz and amethyst are blended with consummate art.

\*

There are splendid liquor flasks for the feminine traveler. These are of cut glass with tops of silver, finished rose gilt.

\*

Traveling bags, now in demand, are more sumptuous than ever. The newest ones contain a leather easel which, taken from an inside pocket, displays an array of silver mounted toilet accessories.

\*

An effectual ornament is a tiara which also forms a necklet of symmetrical pattern. It is composed of scrolls and fleur-de-lys of brilliants, with knife-edged wire below the scrolls studded with brilliants.

\*

Dragon flies with diamond bodies, ruby eyes, gold legs and wings of opal, masquerade as brooches.

\*

A London jeweler has brought out a brooch for fiancées. The setting is a light and graceful one of tiny diamonds, and in the center are two opal love birds. By touching a spring these fly apart, and a miniature likeness of the giver appears.

\*

Cut glass pitchers of tankard shape come in a variety of sizes.

\*

Among the newer handkerchief bags are those woven from silk, with beads interwoven here and there, the bags have mountings of silver, enameled or gilded.

\*

Enameled bonbonnières, set with jewels, are in heart shape, square and oblong.

\*

The leather case of her bicycle clock must now be of the same color as the young woman's costume.

\*

Novelties in German Delft have appeared in the popular blue decoration, and include ice dishes, biscuit jars, boudoir sets and the like.

\*

A necklace well suited to a young lady has one row of pearls encircling the throat, and from this are suspended festoons of pearls, kept in place by brilliants at each junction.

ELSIE BEE.

**ADMINISTRATORS' SALE OF Jewelers' Lathes and Attachments.**

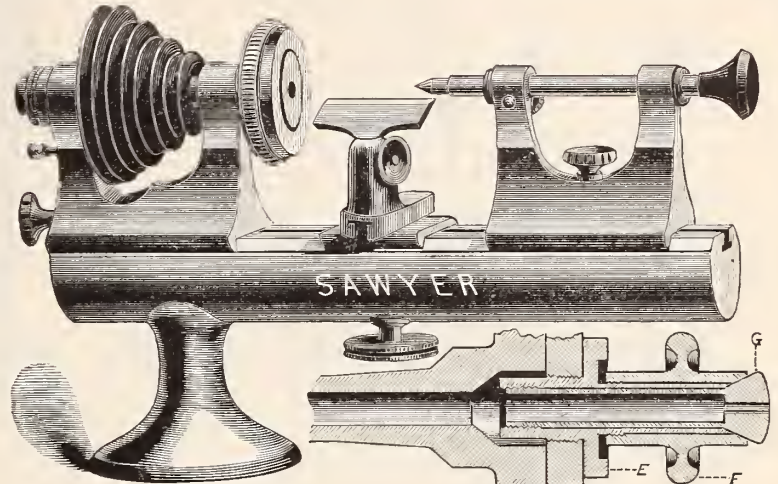

A, Head or Face-plate that carries the rest of centering device; D, Tool holding plate; B, Clamp nut; C, Clamp cap; a, Circular spring that keeps the tool holding plate lightly in position while centering; E, Chuck stock; F, Binding nut; G, Split chuck.

To Settle the Estate of SYLVANUS SAWYER, Late of Fitchburg, Mass.  
**A RARE CHANCE TO PURCHASE AN OUTFIT CHEAP.**  
 SEND FOR CIRCULAR AND PRICE LIST TO B. E. SAWYER, ATHOL, MASS.

**MATHEY BROS., MATHEZ & CO.,**

Brassus, Switzerland. 21 & 23 Maiden Lane, N. Y.

SOLE AGENTS:

**CHAS. MEYLAN WATCHES.**

**SPLITS**

A SPECIALTY.



**IN EVERY HOME**

There is a possibility of placing at least one of these beautiful groups.

Price of this one, \$10.00

A writer in the "New England Magazine" says, "There are few men in this country, among the artists, who know the horse as well as Rogers."

Send for Handsome Catalogue and Trade Prices.

**Rogers Statuette Co.,**  
 441 Pearl St., N. Y.



# Our Trade Mark

Seen on  
silver  
Shows  
Sterling



.925 Fine

J. B. & S. M. KNOWLES CO.,

PROVIDENCE, R. I.

MAKERS OF . . . . .

HIGH GRADE

# Artistic Silverware.

OPPENHEIMER BROS. & VEITH,

CUTTERS OF DIAMONDS,

DEALERS IN WATCHES,

65 NASSAU STREET (PRESCOTT BUILDING), NEW YORK.

## AMERICAN WATCH CASE CO.,

11 JOHN STREET, NEW YORK.

Manufacturers of FINE SOLID GOLD CASES.

Sold DIRECT to  
the RETAIL TRADE only.

**A.W.C.CO**

## PATEK, PHILIPPE & CO., GENEVA, SWITZERLAND.

MAKERS IN THE HIGHEST QUALITY OF

Fine, Plain, Complicated  
And Decorated Watches

IN 15 DIFFERENT SIZES.

INTERCHANGEABLE PARTS.

NEW YORK OFFICE, 68 NASSAU ST. ALFRED G. STEIN, Representative.

**ANY BOOK** pertaining to the Jewelry, Horological, Optical or kindred Trades can be obtained through the Jewelers' Circular Publishing Co., 189 B'way, N. Y. Send for new catalogue, just issued. It is free.

### Interesting Case Bearing Upon the Subject of Stolen Goods.

NEW BRITAIN, Conn., June 5.—A case exciting much interest among New Britain jewelers was on trial here Tuesday. Wm. H. Butler lost a \$125 diamond in a cafe. It was found by Jacob Senf, who, as claimed, abstracted the stone and returned the setting to Butler. Senf afterward sold the stone for \$25 to jeweler Wilbur C. Lewitt, who turned a diamond over to the chief of police, when he and Senf were arrested. Mr. Butler testified that the stone turned over by the jeweler was not his but was a cheap grade stone. He paid \$120 for his stone to Jeweler Kohn, Hartford.

Jewelers William T. Burritt and S. H. Wood, of New Britain, who were called in as experts, both testified that Senf offered to sell them a diamond which was much more valuable than the one produced in court. Senf admitted that he found the diamond and sold it to jeweler Lewitt. Senf was bound over to the Superior Court under bonds of \$500.

Jeweler Lewitt, who bought the diamond and afterwards refused to give it up until he was arrested, was defended by Attorney Gussman, who asked that his client be discharged as he did not know the jewel was stolen. Lewitt testified that he bought the diamond in good faith and paid \$25 for it, and afterwards sold it to Peter Farrell. When the State's evidence was all in Mr. Gussman asked that the case be dismissed on the ground that the section under which the case was brought said that a crime was only committed when the receiver of stolen goods knew when he bought them that they were stolen. Judge Andrews reserved his decision.

Thomas Hutchinson, who has been employed by W. S. Taylor, Utica, N. Y., as traveling salesman, was arrested a few days ago on a warrant charging him with the larceny of watches, scarf pin and rings, in all to the value of \$100. He pleaded not guilty and gave bail for his appearance.



BATES & BACON  
"FAVORITE"  
14K

## ALWAYS

Ask to see  
our



BATES & BACON  
"ROYAL"  
14K

GOLD FILLED  
WATCH CASES.



BATES & BACON  
"PURITAN"  
14K

None Better  
and  
Few Equal.

## The Plan of the Proposed Watch Jobbers' Association.

Below is the plan in full drawn by Elihu Root, on which the proposed new association of watch jobbers is to be based. Copies of this plan have already been and are being sent to the wholesale watch trade in general. The plan is :

We, the undersigned jobbers of American watches, hereby associate ourselves together for the purpose of establishing a certain and trustworthy means of knowing who are entitled to be treated in the trade as wholesale dealers or jobbers; of promoting uniform methods of conducting business in conformity to sound principles of credit; and of securing fair and open competition and preventing secret rebates and discriminations.

To these ends we agree as follows:

I. The name of the association shall be  
II. The members shall be the several individuals, firms and corporations who subscribe to these articles.

III. Every dealer who is legitimately engaged in the wholesale watch or jewelry business, keeping a stock of American movements and cases in proportion to the amount of his general business, and shall be deemed to be a jobber or wholesale dealer. Every dealer doing business within the United States who answers to the foregoing definition of a jobber, and who is of good character and reputation, shall be entitled to subscribe to these articles and to become a member of this association.

IV. There shall be a meeting of the association in each year, at which the members may vote either in person or by proxy. The first meeting shall be held within thirty days after these articles take effect, at a time and place to be fixed by the first three signers of the articles. Each subsequent annual meeting shall be held on the third Tuesday of January, at such place as may be designated by the president. Two weeks notice of every annual meeting shall be given by mail to each member. Each firm and corporation shall be deemed to constitute a single member and shall be entitled to a single vote.

V. The association shall have a president, a vice-president, a secretary and treasurer, and a board of seven directors, all of whom shall be chosen at the Annual Meeting by ballot, and shall serve until the next annual meeting, or until their successors are chosen, and who shall perform the duties usually performed by such officers. The president and vice-president shall be ex-officio members of the board of directors.

VI. Special meetings of the association shall be called by the president whenever five directors request it in writing. Two weeks notice of every special meeting shall be given to each member by mail.

VII. Vacancies in office shall be filled by the board of directors until the next annual meeting.

VIII. The secretary shall use diligence to ascertain what dealers in the United States are entitled to be considered jobbers in accordance with the foregoing definition, and shall keep a list of dealers so entitled in his office, at all times open for inspection of members, and of all manufacturers with whom any members of the association deal, and he shall annually transmit to each member, and to all such manufacturers, as far as known to him, a printed copy of said list, designating thereon which are and which are not members of the association.

IX. Each member agrees to lodge with the secretary during the month of January in each year a true and complete printed copy of his price-list of all American watches, watch movements, and gold-filled, silver, and base metal watch-cases in which he deals; and whenever

he changes his price for any article mentioned in said list, he agrees to communicate the change to the secretary in writing, at least ten days before he begins to sell at such changed price; and whenever he begins to deal in any new article not mentioned in his price-list, he agrees to communicate his price for such article to the secretary before beginning to deal therein. Such lists and prices shall be at all times kept by the secretary at his office, open to the inspection of the members and of the manufacturers conforming to this article, as hereinafter provided. The prices so listed and communicated to the secretary shall be in each case the long price, or the price before deducting any discounts, commissions, rebates or allowances to purchasers, and shall in each case be accompanied by a statement of fixed and uniform rates of discount, commission, rebate or allowance, made, given or allowed by such dealer to his purchasers, if such dealer makes, gives or allows any discounts, commissions, rebates or allowances whatever, or intends so to do. Each member agrees that the prices so listed and communicated to the secretary shall be the true and actual prices at which he sells, and that the rates of discount, commission, rebate or allowance so stated by him to the secretary shall be the true rates, if any, allowed by him upon his sales, and that whenever he changes his price as to any article in any transaction or to any purchaser whatsoever, the change shall be made by changing the list price and giving due notification thereof to the secretary as aforesaid, and not in any case whatever by a change of discount, commission, rebate or allowance, or by any other secret or private variance from the prices held out to the public and listed as aforesaid.

X. Whenever a member fails in business he shall thereby be suspended from membership, and the secretary shall notify all the members thereof. Any member so suspended may be reinstated by the board of directors upon his own application, but only after direct inquiry of all manufacturers to whom he was indebted as to the cause and character of the failure. In case any member so suspended shall not apply for reinstatement within one year, his membership shall cease.

XI. It shall be the duty of the officers and directors to urge upon both retailers and manufacturers the advantage of doing business with jobbers who answer to the requirements and are willing to conform to the provisions of these articles. If any manufacturer of American watches shall agree to adopt and act in his business upon the definition and classification of jobbers herein contained, and shall further enter into an agreement substantially the same as that made by members in and by article IX hereof, the board of directors is authorized to agree with such manufacturer that the price lists and statements of prices and discounts of such manufacturer shall be received, filed, kept open for inspection in the secretary's office of the association, published and distributed in like manner with the lists and prices of members of the association, and further to agree to officially recommend to all members of the association that they make their purchases from such manufacturer and other manufacturers entering into similar relations, and further to agree that in case such manufacturer shall desire to offer special facilities or special advantages to members of the association, the office and the services of the secretary and treasurer of the association and the other organization and machinery of the association may be used by such manufacturer in offering and giving such special facilities. Such agreements shall be made by the president and secretary in the name of the association, under the authority of the board of directors.

XII. A breach by any member of any of the provisions of these articles shall be cause

for expulsion from the association. Dishonesty in business transactions shall be cause for expulsion. The board of directors shall have authority to determine whether applicants for membership conform to the foregoing requirements so as to be entitled to subscribe to these articles, and become members of the association, and to expel members for the causes herein stated.

The board may vest these powers in committees of their number appointed by them, but the action of such committee shall be subject to review by the board on the request of any rejected applicant or accused member.

XIII. The board of directors shall have the general management of the business and affairs of the association. It may adopt by-laws to regulate the business and affairs of the association, subject to alteration by the association at its annual meeting. The board shall hold meetings at such times as they may fix by their by-laws, and such special meetings as shall be called by the president. Five members of the board shall constitute a quorum. Each member of the board may at the annual meeting of the association name an alternate to act in his place whenever he is absent.

XIV. These articles may be amended or altered by vote of two-thirds of the members present in person or by proxy at any annual meeting, but no such amendments or alterations shall be inconsistent with the purposes herein declared.

XV. These articles shall take effect when signed by jobbers of American watches.

Dated, A. D. 1896.

*This agreement, made between*  
(hereinafter called the manufacturer), and  
The  
an association composed of jobbers of American watches, (hereinafter called the association), witnesseth:

In consideration of the mutual promises herein contained and of one dollar to each in hand paid by the other, the parties hereto agree as follows:

*First:* That the manufacturer shall adopt and act in his business upon the definition and classification of jobbers contained in the articles of association of the

*Second:* That the Manufacturer shall lodge with the Secretary of the Association during the month of January in each year a true and complete printed copy of said Manufacturer's price list of all the American watches, watch movements, and Gold-filled silver and Base Metal watch cases produced or sold by said Manufacturer; that whenever said Manufacturer changes the price for any article mentioned in said list the Manufacturer agrees to communicate the change to the Secretary in writing at least ten days before beginning to sell at such changed price, and whenever the Manufacturer begins to deal in any new article not mentioned in said price-list the Manufacturer agrees to communicate the price of such article to the Secretary before beginning to deal therein. That such lists and prices shall be at all times kept by the Secretary at his office open to the inspection of the members of said Association and of all Manufacturers entering into agreements similar to that in this article contained. Such lists and prices and all changes therein as from time to time are communicated to the Secretary, shall be by him communicated to said members and Manufacturers.

The prices so listed and communicated to the secretary shall in each case be the long price before deducting any discount, commission, rebates or allowances to purchasers, and shall in each case be accompanied by a statement of fixed and uniform rates of discount, commission, rebate, or allowance, made, given or allowed by such manufacturer to purchasers, if such manufacturer makes, gives or allows any discount, commissions, rebates or allowances whatever, or intends so to do.

**DIAMONDS.**

**Wm. S. Hedges & Co.,**

IMPORTERS OF

**Diamonds and Precious Stones.**

DIAMOND JEWELRY.

170 Broadway, New York.

22 Holborn Viaduct, London.

**Alfred H. Smith & Co.,**

IMPORTERS

DIAMONDS

AND

PRECIOUS STONES,

182 BROADWAY, COR. JOHN STREET,

NEW YORK.

Venetian Building, 34 & 36 Washington St.

CHICAGO, ILL.

**Purchasers**

... OF ...

**RARE GEMS,**

PRECIOUS STONES  
AND ALL GOODS FOR  
JEWELRY,

ADDRESS

**R. A. KIPLING, Paris,**

**19 Rue Drouot, France.**



**L. BONET**  
ESTABLISHED 1866.

**CAMEO  
PORTRAITS**

Works of Art,  
Precious Stones.

927 BROADWAY  
NEW YORK

DON'T FORGET THE JEWELERS' CIRCULAR PUBLISHING CO.'S BOOK LIST when in want of any technical book in the Jewelry or Kindred Trades.

**SCHULZ & RUDOLPH,**

IMPORTERS AND CUTTERS OF

**DIAMONDS AND OTHER PRECIOUS STONES,**

(Successors to JOHN E. HYDE'S SONS.)

Sole Agents for **The Celebrated Jules Jurgensen Watches.**

28 JOHN ST. and 65 NASSAU ST., NEW YORK.

**The Bowden Rings**

ARE COMPLETE IN VARIETY, CORRECT  
IN QUALITY AND PERFECT IN FINISH.  
WE MAKE EVERY VARIETY OF FINGER  
RINGS.

**J. B. BOWDEN & Co.,**

3 MAIDEN LANE,

**NEW YORK.**

BRANCH OFFICE :

206 KEARNY STREET

SAN FRANCISCO, CAL.

The manufacturer agrees that the prices so listed and communicated to the secretary shall be the true and actual prices at which the manufacturer sells, and that the rates of discount, commission, rebate or allowance, so stated to the secretary, shall be the true rates, if any, allowed by the manufacturer upon sales, and that whenever the manufacturer changes the price as to any article in any transaction or to any purchaser whomsoever, the change shall be made by changing the list price and giving the notification thereof to secretary as aforesaid, and not in any case whatever by a change of commission, discount, rebate or allowance, or by any secret or private variance from the prices held out to the public and listed as aforesaid.

*Third:* That the officers and directors of the association shall officially recommend to all the members of the association that they make their purchases from said manufacturer and other manufacturers entering into similar relations with the association.

*Fourth:* That in case the manufacturer shall desire to offer special facilities or special advantages to members of the association, the office and services of the secretary and other organization and machinery of the association may be used by said manufacturer in offering and giving such special facilities.

*Fifth:* The manufacturer hereby offers to give to all members of the association purchasing goods from the manufacturer a discount or commission of per cent. upon the manufacturer's list prices of all goods so purchased.

*Sixth:* The manufacturer hereby offers for the purpose of inducing the purchase of goods the following special advantage to members of the association, that is to say :

The manufacturer will pay to the treasurer of the association upon the first day of each month, a sum equal to per cent. upon the manufacturer's list price of all goods purchased from such manufacturer by members of the association during the preceding month, such sum to be deposited with such bank or Trust Co. as may be designated by the board of directors, subject to the condition that each member of the association who shall, within thirty days after the first day of the months of April, July, October and January of each year, establish as hereinafter provided, the fact that he has, during the preceding three months, purchased American watches, watch movements, and gold-filled, silver and base metal cases, exclusively from said manufacturer and from such other manufacturers as shall have entered into similar agreements with said association, and from no other manufacturer, and has faithfully kept all the agreements of the articles of association, shall receive from the money so paid in, a sum amounting to per cent. upon the list price of all purchases of American watches, watch movements, and gold-filled, silver and base metal watch cases, made during the preceding three months by such member from such manufacturers or any of them.

*Seventh:* The manufacturer agrees not to extend to or allow to any dealer who is not a member of said association any similar advantage, or any greater commission, discount, rebate, or allowance, than that stipulated for in the foregoing fifth article of this agreement.

*Eighth:* Any part of the sums paid to the treasurer of said association as hereinbefore provided in excess of the sums to which the members show themselves to be entitled, shall become the property of the association.

*Ninth:* The claims of the members of the association to payment out of the fund pursuant to the sixth article, shall be made in writing to the treasurer. They shall state expressly over the signature of the claimant, upon a blank furnished by the secretary, whether the claimant has faithfully kept all the agreements of the articles of association,

and purchased exclusively from the manufacturers specified in the sixth article hereof, and shall state the dates and amount of purchases from each manufacturer, and shall annex the original bills. If the right of any member to the payment of his claim is disputed by any manufacturer, or any officer or member of the association, the controversy arising thereupon shall be submitted to the determination of three arbitrators, one chosen by the treasurer, one by the claimant, and the third by the two so chosen, but none of them shall be either jobbers, manufacturers, or dealers in watches.

*Tenth:* In case the manufacturer reduces the price of any of his goods, he agrees to give a rebate to members of the association, upon all the goods so reduced in price, which they actually have in stock and unsold, at the time the reduction is made.

MR. NOYES CANVASSING THE WESTERN TRADE.

CHICAGO, Ill., June 6.—J. H. Noyes, former secretary of the National Association of Jobbers in American Watches, is here with a proposition for a new association. Papers had previously been sent to all the jobbers and Mr. Noyes is making a circuit of the west for the purpose of getting an expression from them as to the advisability of forming a new association. He states that the trade are favorable and that he is meeting with more encouragement than anticipated.

The object of the association, in a nutshell, is to secure a reasonable profit on certain goods handled and that measures to insure this should proceed from the manufacturers.

THE SENTIMENT OF THE CINCINNATI JOBBERS.

CINCINNATI, O., June 6.—The jobbers are in receipt of a circular letter from J. H. Noyes relating to a new association of watch jobbers to protect prices, etc. A sentiment is desired from the craft on the subject. As far as THE CIRCULAR correspondent can learn there is an indifference on the subject. One jobber said that there would be no sales if the prices were maintained, as only those who were cutting the life out of watch prices were selling any. Many of the jobbers have ceased to push the watch trade. Side lines and novelties are the principal sales. A leading jobber is said to be selling silver watches at a loss. Mr. Noyes is expected in Cincinnati and a meeting will probably be called.

The store of F. W. Maechler, Campbell, Minn., was burglarized a few nights ago and a large amount of cutlery jewelry and was taken. The thieves were captured.

Jacob Katz was released from court by Justice Janetzke in Baltimore, Md., June 3d, charged with obtaining \$34 from Thomas A. Elliott under false pretenses. Katz is a jeweler, and Elliott alleges that he sold him a watch, which Katz said was gold; it was not gold. Katz was about to leave on the steamer *Neckar* for Bremen when arrested. He had jewelry to the value of about \$3,000 in his possession when arrested. His wife and baby waited in vain at the steamship pier to see him off. When he was released, the steamer had gone.

ESTABLISHED 1840.

LANDEL, BAREMORE & BILLINGS,

IMPORTERS OF

DIAMONDS,

AND OTHER PRECIOUS STONES.

FINE PEARLS A SPECIALTY.

MANUFACTURERS OF

DIAMOND JEWELRY

A Large Stock of Fine Mounted Goods Constantly on Hand.  
Goods Sent on Approval and Insured in Transit.

Diamonds Cut, Recut and Repaired.

58 Nassau Street,  
29 Maiden Lane,  
NEW YORK.

1 Tulp Straat,  
AMSTERDAM.

1 St. Andrew's St.,  
Holborn Circus,  
LONDON E. C.

ESTABLISHED 1841.



CARTER, HASTINGS & HOWE,

MANUFACTURERS OF

GOLD JEWELRY,

15 MAIDEN LANE, NEW YORK.

A. CARTER,  
C. E. HASTINGS,  
W. T. CARTER  
G. R. HOWE,  
W. T. COUGH

FACTORY, NEWARK, N. J.

JOHN P. CAMPBELL,  
MANUFACTURER OF  
WATCH CASES.

ALL KINDS OF SPECIAL CASE WORK.  
REPAIRING A SPECIALTY.

59 Nassau St., Cor. Maiden Lane, New York.

Royal Arcanum and Maltigue Ladies' Enamel Cases

HERMAN KOHLBUSCH, SR.

Established 1859  
Manufacturer of  
FINE BALANCES  
AND WEIGHTS for  
every purpose  
where accuracy is  
required. 59 Nassau  
Street, cor.  
Maiden Ln. N. Y.

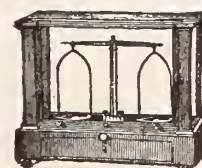

Repairs (any make)  
promptly made.

## Annual Meeting of the Chicago Jewelers' Association.

F. A. HARDY, - - - - - President.  
BENJAMIN ALLEN, - - - - - Vice-President.  
J. A. TODD, - - - - - Secretary and Treasurer.

### DIRECTORS

L. W. FLERSHEM, A. L. SERCOMB,  
G. W. CHURCH, W. M. G. PRALL,  
M. N. BURCHARD, C. H. KNIGHTS.

CHICAGO, Ill., June 3.—The Chicago Jewelers' Association held its annual meeting yesterday, and elected officers and directors for the year as above. Of the officers of the past year J. A. Todd was re-elected, Grove Sackett



F. A. HARDY,  
PRESIDENT, CHICAGO JEWELERS' ASSOCIATION.

was succeeded by Mr. Hardy, and F. M. Sproehle was succeeded by Mr. Allen. The incoming officers are men of the highest standing in their respective lines and cannot fail to advance the interests of the association. F. A. Hardy, president, is head of the great optical house of F. A. Hardy & Co.; Benjamin Allen is a name synonymous with wholesale jewelry throughout the country, and J. A. Todd is manager of the Towle Mfg. Co., silversmiths.

The association over which these gentlemen preside is one of far-reaching benefits to the members and an influential factor in western trade circles. Formed in 1876, it long since ceased to be an experiment, and casting aside the fledgling wings of youth it this season enters upon its 21st year—a year of vigorous manhood. With the object of cultivating friendly relations, promoting the best interests of its members, and obtaining and diffusing accurate and reliable information among its members as to the standing of jewelers and other matters, the Chicago Jewelers' Association has so added to its facilities and extended its operations, that it stands foremost among the commercial bodies of the west, and in its success every man prominent in jewelry jobbing circles has taken an active interest.

The present membership includes the following representative houses:

Benj. Allen & Co., A. C. Becken, Dennison Mfg. Co., Elgin National Watch Co., Geneva Optical Co., Wm. L. Gilbert Clock Co., Gorham Mfg. Co., H. F. Hahn & Co., F. C. Happel Co., F. A. Hardy & Co., Juergens & Andersen Co., C. H. Knights & Co., Lapp & Flershem, Lyon & Healy, G. W. Marquardt

& Sons, Meriden Britannia Co., F. E. Morse Co., New Haven Clock Co., Pairpoint Mfg. Co., Robbins & Appleton, Rockford Silver Plate Co., Rockford Watch Co., Rogers & Hamilton Co., Seth Thomas Clock Co., Simpson, Hall, Miller & Co., Alfred H. Smith & Co., F. M. Sproehle & Co., Stein & Ellbogen Co., Towle Mfg. Co., R. Wallace & Sons Mfg. O. W. Wallis & Co., Waterbury Clock Co., Waterbury Watch Co., Otto Young & Co.

A special feature of association work has been the reports on standing of jewelers and the collection department, conducted under the experienced eye of Abner Hurd, assistant secretary. These departments alone have saved members many times the cost of membership, which simply covers the necessary expenses of operation. The benefits to be derived from membership make it a necessity for every first-class house to receive its reports. The association has handsome quarters on the seventh floor of the Columbus Memorial building, southeast cor. Washington and State Sts.

### The Assets and Liabilities of Wood, Bicknall & Potter.

PROVIDENCE, R. I., June 3.—The petition in insolvency of Wood, Bicknall & Potter was filed in the Appellate Division of the Supreme Court this week. The assignment of the firm to James M. Scott had already been recorded and since that time a list of the assets and liabilities had been prepared and sworn to before Stephen O. Edwards and was filed



BENJ. ALLEN,  
VICE-PRESIDENT, CHICAGO JEWELERS' ASSOCIATION.

with the petition. The liabilities of the firm amount to \$77,628.75; those of George H. Wood to \$2,018.34; those of Frank J. Bicknall to \$10,199.14; those of J. H. Potter to \$5,315.89.

The assets of the company include stock, fixtures, delivery system, real estate taxed at \$6,020, on which there is a mortgage of \$2,000, and book accounts amounting to \$25,000. The individual assets of the partners include real estate at the corner of Thurber's Ave. and Plane St., on Calla St., a quarter interest in an estate corner Nursery and Hamburg Sts., and a quarter interest in a wood lot and farm-

house and lot at Richmond, R. I. The creditors of the house include among their number firms in Bremen, Germany; Liverpool, Eng.; and firms at various places in Massachusetts, Rhode Island, Connecticut, New York, Pennsylvania, New Hampshire, New Jersey, Ohio, Illinois, and Washington, D. C. Among those interested are:

Barbour Silver Co., Hartford, Conn., \$195.96; Adelphi Silver Plate Co., New York, \$446.44; Dominick & Hafl, New York, \$578.40; Manning, Bowman & Co., Meriden, Conn., \$118.60; J. D. Bergen, Meriden, Conn., \$450.06; Middletown Plate Co., Middletown, Conn., \$168.80; Bradley & Hubbard Mfg. Co., Meriden, Conn., \$2,909.93; Coddling Bros & Heilborn, Attleboro Mass., \$135.62; Howard Sterling Co., Providence,



J. A. TODD,  
SECRETARY AND TREASURER, CHICAGO JEWELERS' ASSOCIATION.

\$814.53; Kent & Stanley Co. Ltd., Providence, \$172.36; Meriden Cutlery Co., Meriden, Conn., \$711.59; Pairpoint Mfg. Co., New Bedford, Mass., \$269.70; Reed & Barton, Taunton, Mass., \$132.15; Simpson, Hall, Miller & Co., Wallingford, Conn., \$1,530.41; Whiting Mfg. Co., New York, \$412.16; Derby Silver Co., Birmingham, Conn., \$92.79; Rogers & Hamilton Co., Waterbury, Conn., \$580.57; Wilcox Silver Plate Co., Meriden, Conn., \$1,461.52; C. Dorfinger & Sons, New York, \$240.54; St. Louis Stamping Co., St. Louis, Mo., \$1,203.28; Fessenden & Co., Providence, \$3.01; Palmer & Peckham, North Attleboro, Mass., \$234.69; Miller Bros. Cutlery Co., Meriden, Conn., \$55.90; H. H. Curtis & Co., North Attleboro, Mass., \$124.06; Waterbury Clock Co., New York, \$448.24; Foster & Bailey, Providence, \$43.18; Webster & Co., North Attleboro, Mass., \$136.00; Hamilton & Hamilton, Jr., Providence, \$94.33; Meriden Silver Plate Co., Meriden, Conn., \$28.87; Bristol Brass & Clock Co., Bristol, Conn., \$376.49; Oneida Silverware Mfg. Co., Oneida, N. Y., \$28.26; Homan Silver Plate Co., Cincinnati, \$93.53; W. H. Manchester & Co., Providence, \$5.99; Campbell & Metcalf Silver Co., Providence, \$17.60; Meriden Britannia Co., Meriden, Conn., \$12.53; E. A. Bliss Co., Meriden, Conn., \$10.50; Clafin & Co., Providence, \$38.44; Alling & Co., New York, \$42.75; Alvin Mfg. Co., New York, \$154.90; Wertheimer & Co., New York, \$34.88; W. J. Braitsch & Co., Providence, \$17.88; F. T. Pearce & Co., Providence, \$450.00.

Theo. G. Walpuski and Conrad Leise, proprietors of the American Morocco Case Co., 40 E. 19th St., New York, several months ago established a western branch at 206 State St., Chicago. The Chicago house is conducted under the name of the Western Jewelry Case Co. This venture will doubtless be as successful as the New York company, who are known for the splendid product of their factory. They will manufacture in Chicago as in New York fine cases for jewelry and silverware, hardwood trunks, trays of all kinds and window display forms.

### Death of Augustus S. Chase, President of the Waterbury Watch Co.

WATERBURY, Conn., June 7.—A cable dispatch received in Waterbury to-day announces the death in Paris, France, of Augustus S. Chase, of Waterbury. Mr. Chase was one of Waterbury's foremost men, and a leader in its industrial and financial enterprises. He was president of the following corporations: The Waterbury National Bank, the Waterbury Watch Co., the Benedict & Burnham Mfg. Co., the Waterbury Buckle Co. and the American Printing Co. He was financially interested in other large corporations, was the first treasurer of the city of Waterbury, and had served on the city's School and Water board. He was also treasurer of the Sinking fund. A few years ago he represented the town in the General Assembly. He was 68 years old and was a native of Pomfret, Conn.

Augustus Sabin Chase sailed for Europe March 21, with his wife and one of his daughters. They met the other unmarried daughter in Madrid, she having been pursuing her art studies abroad. The family had been in Paris two weeks and expected to return home soon. His second son, Irving H. Chase, sailed last Wednesday to join them and will be in Paris next Monday. Mr. Chase's death was due to heart failure, but was wholly unexpected.

Mr. Chase was born Aug. 15, 1828. He studied in Woodstock Academy and taught school in Brooklyn, Conn. In 1850 he went to Waterbury and was employed in the Waterbury bank, the presidency of which he has held since 1864. Among concerns with which Mr. Chase was identified either as director or stockholder aside from those mentioned were the American Pin Co., American Mills Co., Waterbury Brass Co., Scovill Mfg. Co., Waterbury Clock Co. and the Bridgeport Brass Co. Mr. Chase had acquired a large fortune. His home was at Rosehill Cottage on Prospect St., Waterbury. On Sept. 7, 1854, he married Martha Clark Starkweather, of Chesterfield, Mass., who survives him, together with six children. His sons are Henry S. Chase, manager of the American Printing Co., and treasurer of the Waterbury Mfg. Co.; Irving H. Chase, secretary of the Waterbury Clock Co., and Fredrick S. Chase, now connected with the Waterbury Mfg. Co. His daughters are: Helen Elizabeth, Mary Eliza, wife of A. R. Kimball, assistant editor of the Waterbury *American*, and Alice Martha.

### Philadelphia.

William H. Parke has withdrawn from George Eakins & Co.

W. J. Englehart and John G. Borhek have been enjoying life at Atlantic City lately.

Charles Hollinshed will soon vacate his present quarters on 8th near Chestnut Sts. and open a new store in the northern section of the city.

S. Kind & Co., will take possession of their new store, 928 Chestnut St., about Sept. 15, and announce a removal sale at their Market St. establishment.

In attempting to capture a burglar one night

last week the police in firing at the fugitive broke the large corner window of the store of the Bailey, Banks & Biddle Co., valued at and insured for \$400.

The Newark Jewelers' Association will come to Philadelphia on June 17 to attend the anniversary of the Jeweler's Association of this city. The Newarkers will present their Philadelphia brethren with a beautifully engraved set of resolutions suitably framed.

For great skill and care exhibited in seeing that the costly Swiss clock hanging in the Franklin Institute has always been properly wound up and kept in good condition, Fred Loos, with Louis A. Scherr & Co., has been presented with a timepiece that is almost the counterpart of the one doing duty in the famous old institution.

Alexander Patterson, well known to the jewelry trade through his connection with Simons, Bro. & Co., was united in marriage June 3, to Elizabeth, daughter of W. J. Jordan. The wedding took place at Wylie Memorial Presbyterian church, in the presence of several hundred guests, including many persons connected with the trade.

An answer in the suit instigated by John G. Borhek, against Mrs. Rebecca Jones Borhek, to show cause why she should not render an accounting as the executrix of the estate of her husband, Edward Borhek, deceased, has been filed in court. Mrs. Borhek deals at length with the details of the case and then proceeds as follows: "Your respondent therefore submits that under the testator's will the petitioner, his son, John G. Borhek, is not entitled to claim as a creditor and a legatee, but should be put to his election in the matter, and should set forth the basis of his claims, and show that it is still subsisting, or, waiving his claim as creditor, should show that he has complied with the directions in his father's will contained before your respondent be required to answer the premises further."

### News Items From Here and There.

J. M. Bricker, Nevada, Ia., gave a mortgage for \$464.

L. U. Folsom, Sumter, S. C., has mortgaged real estate for \$600.

A. K. Chamberlain has removed from Kenosha, Wis., to Foster, Ia.

Walter H. Wiesman, Millsbury, Mass., has sold out to E. C. Putnam.

George E. Seibert, Cedar Falls, Ia., recently gave a bill of sale for \$2,829.

Prof. B. B. Clark, eye specialist, is now permanently located with McAllaster & Humburch Brothers, Rochester, N. Y.

Abel King, of I. Emrich & Co., New York, has recovered from his recent illness and expects to resume his trip on the road within a short time.

The engagement was made public last week of Robert C. Hollister, of the jewelry firm of Wetherell & Hollister, Westfield, Mass., to Miss Freda Steiger.

Samuel Kirk & Sons, Baltimore, Md., dissolved partnership, and were succeeded by Henry C. Kirk. A judgment for \$509 has been issued against Henry C. Kirk, Jr.

### Consolidation of the New York Jewelers' Board of Trade and the Jewelers' Mercantile Agency.

Arrangements have been completed which will practically consolidate the New York Jewelers' Board of Trade and the Jewelers' Mercantile Agency, Ltd., of which De Loid Safford, is president. By these arrangements the latter company will lease their reference book to the New York Jewelers' Board of Trade for the period of 10 years at a stipulated sum per annum, and at the end of that time, if the agreement is carried out, the book will become the property of the Board of Trade. In the meantime the machinery of the two associations will be consolidated and Mr. Safford will supervise and control the publishing of the reference book as heretofore.

The negotiations between the two organizations have been going on for a long time and culminated June 5th in the present arrangement. The contract is not yet signed but is expected to be immediately and will take effect July 1st, so that the July book of the Mercantile Agency will come under the lease. All existing contracts of the Jewelers' Mercantile Agency will be carried out.

Until Jan. 1, 1897, it will be optional on the part of members of the Board of Trade to take the reference book on payment of \$35, but after that date the book will be supplied to all the members, and the dues will be raised from \$90 to \$125 per annum. The present Chicago and Providence branches of the Jewelers' Mercantile Agency will both be continued.

De Loid Safford, president of the Jewelers' Mercantile Agency, Ltd. was ill at his home in Roseville, N. J., and could not be seen. President Hodenpyl, of the New York Jewelers' Board of Trade, when seen by a CIRCULAR reporter, confirmed the details as published above and said that there was no doubt the consolidation would be accomplished and would prove beneficial to both organizations.

A general meeting of the New York Jewelers' Board of Trade was called for yesterday afternoon to confirm the action of the directors in making this agreement.

### Failure of the Inter-State Importing & Manufacturing Co.

SYRACUSE, N. Y., June 8.—The Inter-State Importing & Mfg. Co., doing business in the Sedgwick, Andrews & Kennedy building, have been closed by deputy sheriff P. Cahill on an execution in favor of William H. H. Chamberlin, a printer, for \$273.

The Inter-State Importing & Mfg. Co. were organized last November for the purpose of manufacturing and jobbing jewelry. The capital stock was \$10,000, held by C. A. Lockard, E. A. Kingsbury and H. C. Flood. The business, it appears, has not been successful and complications recently arose.

Leslie C. Lane, as assignee for the Reed & De Mars Jewelry Co., Minneapolis, Minn., has been discharged, upon petition, having satisfied the court that he had performed fully his duties as assignee. His bondsmen were also released from liability.

## OPTICIANS DISCUSS THEIR SCIENCE.

First Annual Meeting of the Optical Society of the State of New York, at Syracuse, June 2 and 3.

SYRACUSE, N. Y., June 5.—The first annual convention of the Optical Society of the State of New York was held in Syracuse, Tuesday and Wednesday, June 2d and 3d. There was a large attendance, delegates being present from all parts of the State. A meeting of the following committees of the association was held at The Yates, at 9 o'clock, Tuesday afternoon: Executive, J. J. Mackeown, chairman, New York; George R. Bausch, Syracuse; W. W. Bissell, Rochester; M. E. Kenney, Utica; E. R. Maion, Binghamton; A. J. Cross, New York; Charles F. Prentice, ex-officio, New York.—Reception, Henry S. Fuller, Syracuse; A. O. Palmer, Cortland; F. G. Wilson, Ithaca.—New membership, B. T. Clark, Utica; A. M. Kenney, Utica; O. H. Wright, Ithaca.—Press, S. M. Shimberg, Syracuse; Clarence Sherwood, Auburn; counsel for the society, T. Channon Press, New York.

The regular session opened at 8 o'clock Tuesday evening in the assembly rooms of The Yates. There were about 75 opticians present and great interest was manifested in the papers under discussion. The meeting was opened by an address by the president, Charles F. Prentice, New York, who spoke in part as follows:

### THE PRESIDENT'S ADDRESS.

This society came into existence with a battle cry, in asserting the rights of opticians before one of the highest tribunals of the people in the State. In its fortified position in Albany the society was assailed by oculists, who had swelled their influence to suppress its cause by securing the aid of all of the State medical societies. Through the political power and the misrepresentations of certain medical oligarchs an unsuccessful attempt was made to stifle the society's bill in committee. The society's opponents offered no argument beyond the claims that the society was a "trust," that its utterances were mere "lingo," and that its bill was a pernicious one that "should be killed." Twelve thousand physicians fought like fanatics under their infuriated leaders to dislodge 11 men who had taken the initiative and only honorable position they could in the interest of justice and the preservation of the vested rights of opticians. Falsifications and intimidations were our opponents' only weapons. The dispensing opticians and the general medical practitioners of the State were literally whipped into line to oppose the society in the interest of scarcely 400 oculists. The petitions of the former were trumped up misrepresentations, prepared at the instigation of certain oculists who compelled dispensing opticians to define the functions of the optician from the oculist's standpoint, and to express an opinion respecting glasses and disease of which they are incompetent to judge. The dispensing opticians, though fully aware of the contrary, were led to assert their fear of a so-called "dangerous monopoly" seeking the power to issue certificates at an extortionate price and, if necessary, also to subsequently revoke them, when its displeasure should fall upon offending holders thereof. These certificates were also claimed by them to confer the right upon opticians to fit glasses to the eyes for various troubles of a medical character, thus, with seemingly legitimate force, trickily giving the impression to laymen that glasses are prescribed for symptoms of disease, instead of for congenital structural defects of the eyes.

The oculists' petitions represented that the fitting of glasses was practicing medicine, and that therefore only a "largely educated mind" was competent to prescribe them. That it takes four years to get a mind into the proper medical condition to appreciate the

relations which exist between certain interesting nervous reflexes and the various congenital structural defects of the eyes with which these symptoms are frequently associated. Dilating upon this point, it was claimed that "the medical degree does not however give one the right to practice medicine, to obtain which one must also pass a State examination." Of course, gentlemen, it would have been very impolitic, though honest, for oculists to have also stated that the medical degree does not carry with it a knowledge of optics, nor give the doctor of medicine the right to practice in that department of science which is entirely foreign to the curriculum of medical training. Nevertheless, it was considered by the oculists that the passage of an optical bill would be unjust to the medical profession as well as to a large class of opticians—20, by the way—who needed, and indeed had no right to ask for any protection other than that already accorded them by benevolent oculists. Furthermore, it was claimed that opticians should not adapt glasses, because of their incompetency to detect many grave diseases which first manifest themselves in the eye, and which are only recognizable through the ophthalmoscope by medicalmen, that the discovery of these symptoms often also led to medical treatment, by which useful lives were frequently prolonged." Such being the case, and to be consistent, all general medical practitioners, who now fail to use the ophthalmoscope as a general diagnostic instrument, should also be debarred from practice in consequence of their criminal neglect of the patient's welfare. In their petitions, and to and through the press, it was represented that the optical society was a "trust" and an organization of opticians, which sought the power to legalize opticians to practice in many instances as oculists.

This, as you well know, is basely false. Contrast this with the objects of the society, which are:

1. To oblige opticians, who adapt lenses to the sight, to pass an examination in theoretical and practical optics before a board of examiners to be appointed by the regents of the State.

2. To insist upon opticians being instructed in the use of the ophthalmoscope and applying it as a precaution against their adapting lenses to diseased eyes.

3. To grant certificates only to qualified opticians who practise in their legitimate capacity of adapting lenses by "treating light," and not in any sense to legalize them to practise medicine or surgery, which is treating disease.

On the other hand, compare the oculists' argument with the following unselfish advantages which would accrue from the society's policy:

1. The public would be protected against those opticians who now in many instances traffic upon postulate skill.

2. The best practical results would be secured to the public through the physico-mechanical services of the theoretically informed practical optician, whose entire efforts should be concentrated in the isolated field of optical science.

3. The public's support of such opticians would protect it against the monopoly engendered by the present collusion between oculists and 20 dispensing opticians in the cities of Buffalo, Brooklyn and New York, and which now threatens an autocratic optical service for the entire State.

4. The skilled optician would prove a valuable and reliable assistant to the general medical practitioner, through the former applying his art exclusively to errors of the sight which are corrigible by lenses, and without in any sense conflicting with the physician's pecuniary interests or prestige in his relations to the patient.

Before disposing of the oculists' petitions let me add, gentlemen, that they took special pity upon you by showing the injustice that would be done yourselves by your having to pay \$25 for the privilege of continuing your business. Incidentally, however, let me also remark that they failed to state that they have only been itching for the opportunity of depriving you of your business altogether, and that, too, without any certificate or specified item of cost to you for the serv-

ice. Do not forget, gentlemen, that they had a potter's field burial in store for you. When a few of us objected they became very solicitous of you respecting the charge imposed upon you by the society to prolong your existence.

Mr. Prentice concluded his address with a strong appeal to the members of the society to throw off the yoke which the oculists insisted upon their wearing, and expressed the hope that the guests of the society would join with them in the crusade against "those medical autocrats who fiendishly and unscrupulously shriek for the legitimate optician's annihilation."

Mr. Prentice was followed by A. Jay Cross, New York, who read an interesting and technical paper on "Practical Skiascopy," illustrated by charts.

Dr. Julius King, of the King Optical Co., New York, addressed the convention on the "Requirements of the Optician, Past, Present and Future," illustrated by the use of charts.

He said he was aware of the fact that in Europe the optician had the priority in the fitting of glasses, and physicians referred their cases of refraction to them. In this country it has only been a few years since there were only opticians in the large cities, and for the accommodation of the people the jewelers kept spectacles for sale, but having no qualifications they were sold like any other article of merchandise and customers were obliged to fit or misfit themselves. A few dozen spectacles of the same P. D. and assorted from No. 5 to 30 constituted an optical stock. Spherical lenses, mostly convex, were the only kind used, and their properties or why they were used were not understood.

The optician has been an evolution, the jeweler realizing the necessity of being able in some way to test the sight and correct the defects of vision. The hand chart and optometer were first called into service. These not being satisfactory, the next advance was the trial lenses and distance charts. These only made more evident the necessity of acquiring sufficient knowledge to use these appliances and led to a course of optical lectures, wherein was taught in a theoretical and practical way the subject of refraction of light, properties of lenses, spherical, prismatic and cylindrical, the signs by which the different errors of accommodation and refraction could be detected and their proper correction by the use of lenses.

In the evolution there is a brighter day coming. With the new optical law in operation, the position of the optician will be secured in the community, but to hold an elevated position the optician must not sail under false colors by calling himself an oculist or physician or undertake to prescribe drugs or medicines and so make himself a quack. He should confine himself to the treatment of light by the use of lenses. It is not sufficient that he be able merely to use the test lenses and talk glibly of the errors of accommodation and refraction, the cone and axis of lenses, spasm of accommodation and muscular insufficiencies, etc. He must become skilled in the use of objective methods and not be entirely dependent on the answers of the patients, and any instrument or appliance that will throw light on the defects he is called upon to correct. The ophthalmoscope should be used not for the purpose of diagnosing any specific disease, but as a precautionary instrument, that by its use he may be able to intelligently decide by the appearance of a normal from an abnormal condition, and so determine what cases lie in his legitimate field for lens correction and what patients should be referred to the oculist for treatment. In other words, the optician must understand what he professes to understand, and if he *knows* a thing he knows it as well as anyone, but he must know it.

His remarks were illustrated by charts, and elicited considerable discussion. Charles F. Prentice then read the following paper on "The Optician Treats Light, The Oculist Treats Disease":



Under this title I shall preface my demonstration by these models as follows:

Lenses, prisms, mirrors and reflectors are mechanical agents utilized by the optician, solely and for no other purpose than to treat light by effecting a change in its direction.

Either separately, or in combination, they constitute the vital part of all optical instruments, so that quite irrespective of the purposes to which such instruments are applied, the fact remains that light is treated by and through them in the manner referred to. He whose business it is to utilize the aforesaid refracting and reflecting elements must acquire his knowledge of their properties through research in works of physical science, which is as foreign to medical science as astronomy is to pill-making. The spectroscope, as a creation of the opticians, in the hands of the astronomer or physicist treats light by changing the direction of solar rays and resolving them into the spectrum. The pill-maker's product, based upon the maker's knowledge of pharmacopia, in the hands of the physician, becomes his agent for the treatment of disease.

The optician, the astronomer and the physicist are as intimately and indispensably related to each other in the field of optics as the pharmacist and the physician are to each other in the province of medical science. When medical eye specialists demand absolute jurisdiction over opticians, it will be quite as just and logical for astronomers and physicists to place druggists under their dictum because the latter sell Canada balsam and chemicals. Of course, opticians do not now generally hold the position referred to in their relations to physicists, because many skilled opticians have directed their attentions more especially to adapting lenses to the sight, which under the recognized definition of the term optician, and without infringement of the existing statutory law, they have been perfectly justified in doing. Such opticians have, however, for a long time recognized the importance of doing such work conscientiously and scientifically, and for that reason have advocated a consideration of its aspects towards the medical profession and the public, by forming a society to further acceptable legislation to all concerned. The present attitude of some oculists towards the society is so unreasonable that it is a mere waste of time and energy to argue with them, but since their argument is intended to deceive laymen, it is the duty of skilled opticians to expose their designs by truthfully instructing the public respecting their relative functions and qualifications. The only channel through which this can be accomplished is the public press, which is ever on the alert to disseminate the truth. Our cause should be of particular interest to the press because it is educational, and for the public benefit.

Mr. Prentice then gave a very full and clear illustration by the means of models of static and dynamic refraction. The models used were the ones exhibited at Albany before the Legislature when the Optical Bill was under consideration.

The next paper on the programme, "Asthenopia and its relations to errors of ocular refraction," was necessarily omitted owing to the absence of R. H. Knowles, M. D.

Next followed an extremely interesting paper on "Skiascopy and Ophthalmoscopy," by L. L. Ferguson, demonstrated by lantern protection. The necessity of the skiascope and the ophthalmoscope in the optician's profession was first explained and the paper called forth considerable discussion. Next H. L. DeZeng, jr., of Buffalo, who is the inventor of a refractometer, explained the nature of the instrument, illustrating it by drawings on the blackboard. Following this was "A Phenomenal Case of Myopia" by F. E. Robbins. The case was as follows:

In August, '92, Miss W., aged 28, came to me suffering from almost continuous headaches, told me she had worn glasses for 12 years. When she was 16 years old and during the commencement exercises at the academy at which she was to graduate, she was taken,

as she thought, blind. She was taken immediately to an oculist who prescribed — 4 D which she had worn to the time that she came to me. She said that ever since she had worn the glasses there had seemed to be a blur before her eyes and that she wanted to rub them all the time. On examination I found vision in each eye 20-400 excepting a—4.5 sphere combined with a — 3.25 cylinder axis 180° gave 20-20. I prescribed the — 4.5 combined with — 3.25 cyl., which relieved the headaches and up to the present time are giving perfect satisfaction.

Owing to the lateness of the hour the last number on the programme, "The Prism-Diometer," by Charles F. Prentice, was omitted.

Wednesday morning at 10:15 o'clock the society met in executive session. The reports of the various committees were read and discussed, and considerable general business transacted. The applications of ten new candidates for membership were acted upon, the membership now numbering 115. This would seem to indicate a healthy growth, as the society organized only about four months ago with a membership of 40. The matter of selecting the place for holding the next annual meeting was discussed and left with the executive committee for decision. The convention adjourned at 10 o'clock.

At 2.45 o'clock p. m. the delegates who had not been compelled to leave for home, boarded the steamer *Colonial* as guests of the Syracuse Optical Co. Starting from Clinton St. bridge, the party proceeded by way of the Oswego canal to Onondaga Lake. Brief stops were made at Long Branch and Pleasant Beach, and at Maple Bay a banquet was served. Fred. F. A. Treuleben, New York, acted as toastmaster, and among those who made addresses were: President, Charles F. Prentice; vice-president, George R. Bausch; treasurer, A. J. Cross; Henry E. Kirstein, S. M. Shimberg, M. E. Kinney, E. R. Mason, L. L. Mincer, and Doctor S. B. Craton.

The formal thanks of the delegates to the Syracuse Optical Company were happily expressed by President Prentice. Among those at the tables were Charles F. Prentice, president; A. Jay Cross, F. F. A. Treuleben, Frederick Boger, J. J. Mackeown, T. Channon Press, New York; August Morck, Warren, Pa.; W. E. Kennedy, H. M. Kennedy, B. T. Clark, Utica; H. E. Kirstein, G. R. Bausch, W. H. Morse, H. C. Meilke, L. L. Mincer, Rochester; Max Elbe, Niagara Falls; Judson L. Newing, E. A. Mason, Binghamton; C. F. Fuller, Phoenix; A. O. Palmer, Cortland; G. S. Connell, Fulton; S. M. Shimberg, N. M. Shimberg, William D. Oertel, R. Mendelsohn, Max Finkenstein, Sam Lavine, G. M. Babbitt, M. Tabosky, Henry S. Fuller, D. R. Hakes, D. J. Coleman, D. L. Coleman, Charles Fix, Julius Shimberg, J. Strassburg, S. Brace Craton, M. D., Syracuse, and representatives of the press.

The dinner lasted from 7 to 9 p. m., when the party broke up to return by the *Colonial* to the Iron Pier and thence to the city by street cars. The members arrived back at The Yates about 10.30 o'clock, p. m., many of them leaving for their homes in the evening.

Julius Kauffman has opened up a jewelry repair shop at 286 Virginia St., Charlestown, S. C.

## Herman Keck Sentenced to One Year's Imprisonment.

PHILADELPHIA, Pa., June 6.—Herman Keck, of the Coetermans-Henrichs-Keck Diamond Cutting Co., Cincinnati, has been refused a new trial, and on Tuesday, June 9th, will be called up for sentence on the charge of attempting to smuggle diamonds into this country from Antwerp, upon which he was lately convicted in the United States District Court.

Argument in the famous case, on the motion for a new trial, took place before Judge Butler, on June 4th, and attracted considerable attention. The addresses of counsel on both sides were made with great vigor, A. S. L. Shields appearing for the convicted man, while United States District Attorney James M. Beck disputed the points Mr. Shields claimed on behalf of Keck. Judge Butler carefully reviewed the case and ruled that he could see no just reason for granting the defendant another trial. The motion for a new trial was overruled and the court ordered that the conviction stand. Mr. Beck will move for the sentence of Keck on Tuesday, and in the meantime the defendant will remain at liberty under the \$10,000 bail furnished by a surety company.

On Wednesday, June 17th, the 563 diamonds seized by Government officials on board the steamer *Rhyndland*, and for smuggling which Keck was convicted, will be sold at public auction. United States Marshall Reilly will conduct the sale at his office, in the Post Office building. In the bills of indictment the diamonds are valued at \$10,000. This figure has been largely reduced by other valuations now ranging in the neighborhood of \$7,000. Some of the stones are pronounced strictly first class in every respect, but in view of the trouble they brought to Keck and others, it is not thought that they will bring anywhere near their full value at this sale.

KECK SENTENCED TO 1 YEAR'S IMPRISONMENT AND FINED \$200.

PHILADELPHIA, Pa., June 9. — Herman Keck was sentenced to-day to one year in the Eastern Penitentiary and fined \$200.

## Last Week's Arrivals.

**THE CIRCULAR** has perfected arrangements for obtaining the names and hotel addresses of all the latest buyers visiting New York, and each day posts in its office, 189 Broadway, a bulletin which every member of the trade is cordially invited to copy.

The following out-of-town dealers were registered in New York during the past week: J. C. Weichel, Scranton, Pa., Imperial H.; W. J. Weichel, Scranton, Pa., Imperial H.; Gen. G. H. Ford, New Haven, Conn., St. James H.; J. B. Mayer, Buffalo, N. Y., Hoffman H.; E. C. Mix, Albany, N. Y., New Amsterdam H.; W. C. Potter, Boston, Mass., St. Cloud H.



## Our Traveling Representatives

Traveling representatives may consider these columns open for the publication of any news or items of interest regarding themselves or their conferees.

**T**HE travelers in Kansas City, Mo., last week were: C. F. Willemin, T. G. Frothingham & Co.; H. C. Bliss, Bliss Bros.; Ernest Block, W. & S. Blackinton; Wm. S. Wightman,

R. F. Simmons & Co.; H. B. Kennion, H. D. Merritt & Co.; M. Solomon, C. P. Goldsmith & Co.; M. S. Jacoby, Providence Stock Co.; G. Rodenberg, S. & B. Lederer; J. C. Hutson, Spencer Optical Mfg. Co.

C. P. Smith, who has traveled for the past 15 years for Otto Young & Co. and C. H. Knights & Co., Chicago, in Indiana, Michigan and Illinois, has accepted a position with Leys, Trout & Co., New York, to show their extensive line in the same territory.

The following traveling salesmen passed through Detroit, Mich., last week: Samuel Heller, L. Heller & Co.; Frank Snow, C. C. Darling & Co.; J. M. Morrow, the American Watch Case Co.; Mr. Tinker, for W. B. Durgin; J. R. Goodwin, Carter, Hastings & Howe; W. O. Lamb, George H. Fuller & Son.

Traveling men representing eastern houses, in Louisville, Ky., last week were: Mr. Baker, Jos. Fahys & Co.; E. H. Pelletreau, Shafer & Douglas; Jacob W. Nevins, J. B. Bowden & Co.; Harry Osborn, Howard Sterling Co.; Albert Holzinger, for Fred Kaufman; Charles F. Ketcham, Riker Bros.; Mr. Foster, Unger Bros.; Mr. Carpenter, R. F. Simmons & Co.; Mr. Gregory, Strobell & Crane; and H. B. Beckett, Dennison Mfg. Co.

Among the traveling men in Philadelphia, Pa., the past week were: C. B. Osborn, William Smith & Co.; A. Rutherford, Kirby, Mowry & Co.; F. I. Locklin, Unger Bros.; E. Eckfeldt, Eckfeldt & Ackley; Charles F. Duffy, Enos Richardson & Co.; G. Goldberg, W. & S. Blackinton; L. P. Cook, J. F. Fradley & Co.; A. Wolff, Alling & Co.; George Read, W. B. Kerr & Co.; C. Booth, Hutchison & Huestis; M. Schwarzkoff, Huger & Schwarzkoff.

Traveling men calling on Davenport, Ia., dealers the past week were: L. E. Smith, M. B. Bryant & Co.; E. L. Brown, Riker Bros.; Rudolph Noel, Albert Lorsch & Co.; M. Van Ness, Unger Bros.; E. C. Bowen, Rogers & Bro.; Mr. Terrill, E. Ira Richards & Co.; S. W. Frohlichstein, Henry Froehlich & Co.; A. B. Daggett, Rogers, Smith & Co.; T. H. Pope, for Frank W. Smith; F. F. Stranger, F. C. Happel Co.; Mr. Tinker, for W. B. Durgin; Mr. Bickert, Warner Silver Mfg. Co.

Traveling men in the Hub the past week included: Albert Bushee, A. Bushee & Co.; Gus Strandberg, E. L. Spencer & Co.; S. O. Bigney; Mr. Kurtz, George W. Cheever & Co.; Charles S.

Isabel, L. Strasburger's Son & Co.; Leverett S. Lewis, Randel, Baremore & Billings; John Cummings, A. C. Cummings & Co.; I. L. Russell, L. Tannenbaum & Co.; F. B. Reynolds, Cory & Reynolds; H. A. Clark, Horton, Angell & Co.; Louis Blackinton, W. & S. Blackinton; C. D. Lyons, Torrey Jewelry Co.; Harry Swift, Packard & Swift, C. A. Whiting, Whiting, Davis & Co.; Daniel Robinson, Robinson & Co.; Henry Thresher, Waite, Thresher Co.

Traveling men in Indianapolis last week included: Mr. Goodwin, Carter, Hastings & Howe; G. W. Bleecker, the Bassett Jewelry Co.; Ed. Patterson, Towle Mfg. Co.; Mr. Brown, Ellis, Livsey & Brown; Edwin L. Mumford, Waite, Thresher & Co., Fred L. Pettee, Waterbury Clock Co.; A. H. Oakley, Thornton Bros.; H. B. Kennion, H. D. Merritt & Co.; J. L. Lake, American Waltham Watch Co.; Ernest Block, W. & S. Blackinton; H. E. Cobb, Daggett & Clap; W. A. Lamb, Geo. H. Fuller & Son; H. D. Mix, Wightman & Hough Co.; N. F. Swift, for G. K. Webster; J. F. Ripley, Watson, Newell Co.; F. B. Lawton, Lawton, Spencer & Sherman; H. C. Bliss, Bliss Bros.; Wm. W. Middlebrook, B. A. Ballou & Co.; Mr. Williams, Arnold & Steere; and representatives of the Natchaug Silk Co. and W. H. Wilmarth Co.

Travelers in Pittsburgh, Pa., last week were numerous, and included: E. Untermyer, Charles Keller & Co.; E. Z. Reed, Reed & Barton; E. P. Tiffany, F. H. Sadler & Co.; J. T. Inman, J. T. Inman & Co.; Edwin L. Mumford, Waite, Thresher Co.; Mr. Lamb, T. I. Smith & Co.; H. E. Cobb, Daggett & Clap; J. F. Granbery, F. H. Cutler & Co.; Lawrence H. Smith, Bippart & Co.; Mr. Kennion, John T. Mauran Mfg. Co.; J. M. Morrow, American Watch Case Co.; Charles B. Bartlett, Whiting Mfg. Co.; M. Stratton, Jr., John W. Reddall & Co., H. C. Bliss, Bliss Bros.; Mr. Williams, Arnold & Steere; C. E. Hancock, Hancock, Becker & Co.; C. F. Ketcham, Riker Bros.; Harry Osborne, Howard Sterling Co.; Wm. W. Middlebrook, B. A. Ballou & Co.; H. B. Bliss, Gorham Mfg. Co.; C. W. Battey, Waite, Mathewson & Co.; Mr. Harmer, Solidarity Watch Case Co.; Wm. Rosenberger, A. Wallach & Co.; Mr. Foster, Unger Bros.; E. I. Rogers, Parks Bros. & Rogers; Mr. Oakley, Thornton Bros.; H. B. Kennion, H. D. Merritt & Co.; H. C. Rowbotham, J. Muhr & Bro.; C. F. Willemin, T. G. Frothingham & Co.; S. O. Bigney, S. O. Bigney & Co.; S. L. Barbour, Barbour Silver Co.; W. C. Barry, Larter, Elcox & Co.; Sam H. Fink, Fink, Bodenheimer & Co.; John A. Abel, Lewis, Kaiser & Luthy; Geo. L. Paine, E. I. Franklin & Co.; George H. Coggswill, Geo. L. Vose & Co.; Wm. Bosselman, T. Quayle & Co.; F. W. Bliss, Link, Angell & Weiss, J. L. Lehweiss, for P. S. Eddy; H. B. Richardson, G. A. Dean & Co.

### Canada and the Provinces.

Cyrille Duquet, Quebec, Que., has assigned. W. Hipwell, Westbourne, Man., is in Toronto upon a visit of some weeks' duration.

The stock of the estate of L. Atkinson, Newmarket, Ont., is advertised for sale by tender,

W. H. McCaw, Port Perry, and F. H. Nettleton, Collingwood, were among recent visitors to Toronto.

The business of L. G. Chamberlain, dealer and manufacturer of spectacles, Toronto, was burned out last week.

George Joseph, well known to the Canadian jewelry trade, is on the road again representing Edmund Scheuer, Toronto.

Harry W. Beatty, son of W. H. Beatty, of the Toronto Silver Plate Co., was married on the 2d inst. to Miss Martha Lee, daughter of J. R. Lee, Toronto.

D. R. Dingwall, Winnipeg, Man., spent some days in Toronto lately accompanied by his son. They have gone to Montreal where Mr. Dingwall, Jr., will study the higher branches of engraving.

B. Kent, of B. & H. B. Kent, 144 Yonge St., Toronto, left for an extended European trip on the 3d, accompanied by his wife and daughters. He expects to place large orders for jewelry and novelties in the English and French markets.

### Boston.

Fred H. Pope, of D. C. Percival & Co., has opened for the season a new Summer residence, built for him at West Falmouth.

Buyers in town during the past week included: Col. Charles Osgood, H. A. Osgood & Son, Lewiston, Me.; L. H. Smith, North Easton, Mass.

President E. C. Fitch, of the American Waltham Watch Co., started last week on a two months' outing, which will be spent mostly at Romaine river, Canada, where his penchant for sport with rod and gun can have full swing.

A brilliant June wedding in Boston society was the marriage last Thursday evening of the daughter of Edwin B. Horn, the Boston retailer. It was followed by a reception at the residence of Mr. Horn, and a number of the prominent jewelers of Boston were among the guests.

Henry W. Patterson, of Smith, Patterson & Co., will sail for London June 29, accompanied by Mrs. Patterson. He goes as a member of the famous Ancient and Honorable Artillery Company, of this city, which is to be the guest next month of the London "Ancients." Louis Blackinton, who represents W. & S. Blackinton as salesman to the Boston trade, will also be in the ranks when the Hubites make their appearance on the other side.

The death occurred, last week, of Thomas Tracey Bouve, a well known collector of precious stones. He read a paper, some years ago, on the subject of precious stones before the Boston Museum of Natural History, which was published in their proceedings. He was from boyhood a devoted student of natural history, and had been a member of the Boston Society of Natural History for upwards of half a century. He was for two periods its treasurer, and for many years its president. He was a member of the American Academy of Arts and Sciences, of the American Association for the Advancement of Science, and an honorary member of various other scientific societies.

## EASTERN MANUFACTURERS FEAST.

Annual Outing of the New England Manufacturing Jewelers' Association, held at Narragansett Bay, June 5.

PROVIDENCE, R. I., June 5.—The hot, sweltering weather of to-day drove a large number of the manufacturing jewelers of Providence, the Attleboros and vicinities from their places of business to the delightful sylvan retreat overlooking Narragansett Bay, known as the grounds of the Hauterive Club. It was the occasion of the seventeenth annual outing and meeting of the New England Manufacturing Jewelers' Association.

The party began to assemble shortly before 11 o'clock and at once proceeded to the club house and registered. Here a couple of hours were passed in renewing old acquaintances, discussing political or trade prospects, examining the handsome designs [see page 7, this issue of THE CIRCULAR], furnished by the pupils of the Rhode Island School of Design in competition for the prizes offered by the Association during the past Winter, and listening to songs by different members of the merry company. One feature of the day's usual enjoyment was missing, the athletic sports afield. Lazily on the veranda of the club house lay the foot and base balls and bats and none seemed inclined to disturb them. Even the valiant Billy Leeder was content to remain quiet, while the veteran umpire, Benny Hall, could only recount his former victories on the diamond.

A light lunch, consisting of little neck clams, crackers, cheese, doughnuts, and cigars, was in waiting at the club house, and of this each one upon his arrival did ample justice. Billiards and pool were enjoyed and other diversions indulged in. At 12 o'clock the members assembled on the lawn beneath the trees and the annual business meeting of the Association was held. The members were called to order by President Fanning, who without any ceremonies or remarks, called upon the secretary, W. Osmond Clark, to read the minutes of the last annual session. This was followed by the report of treasurer, H. P. Carpenter, which showed the amount on hand at the commencement of the year to have been \$915.61; total receipts during the year, \$461.18; total expenditures, \$445.85; leaving a balance on hand of \$930.54; membership, 60.

John M. Buffinton, chairman of the executive committee, made an oral report. He said:

It is the duty, at least so we construe it, for your executive committee to furnish entertainments and see that everyone behaves himself. In what manner we have executed our duties you can best be the judges. There is one matter somewhat out of the usual line that this committee has been called upon to attend to the past year, and that is in regard to the disposition of the appropriation which the association made for premiums for jewelry designs by the pupils of the Rhode Island School of Design. Your committee decided that the brooch would give the larger scope for the pupils to work upon, and as a result forty-two very excellent designs were submitted to us, and from those we selected three for awards of prizes and six others for mention as very creditable. I believe that it will prove very beneficial, not only to the members of this association, but to the jewelers at large, if this method of stimulating a study of designing for jewelry is continued, and it would not be

amiss if another appropriation for a similar purpose should be made at this meeting. Another matter came under your committee's hand, for yesterday we received from the management of the World's Fair the diploma and medal that we have been so long expecting and patiently waiting for.

President Fanning in commenting upon the report of the executive committee said that there was nothing that would prove more useful to the manufacturing jewelers than these competitive designs of jewelry. Among those present was Warren S. Locke, principal of the Rhode Island School of Design, upon whom he wished to call for a few remarks concerning the matter.

Mr. Locke stated that "the competition just spoken of in jewelry designing came the nearest to the ideas of the originator of the school, Mrs. Metcalf, of anything that has yet been attempted by the school. And the exhibit now being held at the school certainly marks a red letter event in the school's history. There is no way in which you gentlemen can better expend \$25 than in this. History and experience teaches this both in this country and Europe. Mrs. Metcalf, at the conclusion of the Philadelphia Exposition in 1876 found that the women's committee from Rhode Island had a small balance left, suggested that this be used as the nucleus for the establishment of a school of design. From that humble beginning there has arisen the excellent school which last Winter your association wisely saw fit to endow with a sum of \$25 for the production of designs useful and appropriate to your business uses. I feel that the results of that competition have been very gratifying and successful and that in the future similar competitions may prove even more so."

PRESIDENT FANNING:—It might be well at this time to make an appropriation to the School of Design for the coming Winter's class.

MR. BUFFINTON:—These competitions must ultimately end in untold advantages to the manufacturing jeweler and I would therefore move that \$25 be appropriated for premiums during the coming Winter. It will certainly take but a short time to reach the height of the idea of the jeweler if such advancement is displayed during the next competition as has marked the last one.

PRESIDENT FANNING:—There is another matter that I desire to call to your attention. You are well aware that we have no place as an Association to keep our papers or books. I would therefore suggest that the diplomas and medal received from the Columbian Exposition be presented to the Chairman of the Executive Committee, Mr. John Buffinton. You are all familiar with the hard work which he performed in making the exhibit of the Association a success and I do not know of any one to whom it might be better consigned for safe keeping and one who would treasure it more highly than Mr. Buffinton.

Upon motion of S. E. Fisher the suggestion of President Fanning was adopted. Mr. Buffinton thanked the Association for their high compliment, but stated that he was not entitled to the whole credit of the committee's work. He then paid a high tribute to the assistance of the other members of the committee, Messrs. Pearce and Fisher.

S. J. Heimberger and T. B. Cory, Providence, and J. E. Lynch, North Attleboro, were elected to membership.

The election of officers resulted in the following choice:—President, Joseph H. Fanning; vice-presidents, A. A. Bushee, O. C. Devereux and W. W. Fisher; secretary, W. Osmond Clark; treasurer, Horace F. Carpenter; executive committee, John M. Buffinton,

Frank T. Pearce and Samuel E. Fisher.

This concluded the business of the meeting, and owing to the excessive heat, the mercury having ascended to above 90° in the shade, the meeting adjourned, and shortly after the dinner call was sounded and the members and their guests wended their way across the lawn to the dining hall, where caterer Walter Earle had prepared an elaborate shore banquet. Seated at the tables were:

D. A. Riddle, vice president O. C. Devereux, Marcus W. Morton, secretary Manufacturing Jewelers' Board of Trade, C. B. Duckworth, president Joseph H. Fanning, Warren S. Locke, principal of the Rhode Island School of Design, vice president A. A. Bushee, Harry P. Smith, Gardiner H. Niles, vice president W. W. Fisher, Walter W. Burnham, secretary W. Osmond Clark, Russell C. Smith, treasurer Horace F. Carpenter, John M. Buffinton, Samuel E. Fisher, Frank T. Pearce, Fred I. Marcy, John Heathcote, Capt Benjamin L. Hall, superintendent of the Soldier's Home; H. T. Wood, C. W. Clissold and W. L. Turner, of the Falstaff Club; Walter S. Hough, Jr., William Halkyard, Frank Cutler, Frank Gladding, O. M. Otis, D. E. Makepeace, G. H. Snell, J. P. Carpenter, Edwin Lowe, William N. Otis, G. R. Niven, William Smith, C. A. Howard, W. S. Grant, W. H. Franklin, E. D. Sturtevant; F. R. Capron, Phineas F. Parsous, E. H. Parsons, of the Waterbury Brass Co.; John P. Bonnett, H. W. Niles, Sigmund Lederer, L. Kranz, F. A. Ballou, Geo. M. Baker, Benjamin Lederer, Edward Hough, William Clark, Jr., A. I. Clark, Edward N. Slate, T. B. Cory, Frank B. Reynolds, B. A. Noble, S. E. Kelley, Horace Remington, B. A. Remington, Edward N. Cook, N. B. Nickerson, William Shackelford, Thos. McWilliams, C. S. Heimberger, Peter Lind, N. L. Ripley, S. Baldwin, Samuel H. Bailey, Walter Gardiner, A. T. Manning, David Bernkopf, Otto D. Wormser, of New York; Geo. M. Andrews, Martin S. Fanning, F. H. Andrews, E. A. Woodmancy, J. W. Lawson, Geo. Becker, Jeremiah D. Fowler, W. R. Ellis, Portland Ore.; Wm. Leeder, W. Rosenfeld, New York; John A. Fowler, Arthur Henius, Charles Broome, Wm. H. Mason, THE JEWELERS' CIRCULAR; Charles H. Mathewson, *Jewelers' Weekly*; Walter B. Frost, *Manufacturing Jeweler*; Chas. A. Selden, *Providence News*; Fred. Austin, *Providence Journal*, and William D. Perrin, *Evening Telegram*.

After dinner the company enjoyed themselves to their own inclination and late in the afternoon took the electric cars for the city.

The diploma presented to Mr. Buffinton is in the usual form of those issued by the World's Fair Committee, and after giving the title of the same, continues as follows:

AWARDED TO THE NEW ENGLAND MANUFACTURING JEWELERS' ASSOCIATION, OF PROVIDENCE, R. I.

*Exhibit:* Bracelets, general line of jewelry, charms, chains, lockets and rings.

*Award:* For bracelets and general line of jewelry. The bracelets and general line of jewelry exhibited are all of good design, well made and finished.

(Signed) DAVID PELL SECOR, Individual Judge.

*Charms:* The extensive exhibit of charms, both in gold and plate, manufactured by houses of the highest reputation, and like other exhibits under the name of the "New England Manufacturing Jewelers' Association" has distinct lines of attractiveness and merit.

*Chains:* This, the most important part of this exhibit held under the auspices of the New England Manufacturing Jewelers' Association, is one that should receive the highest praise for its great extent, admirable arrangement and quality of the work shown. The firms in this exhibit are manufacturers of great reputation for the good quality of the work produced.

*Locketts:* The lockets, both in gold and plate with enamel stones, and some with precious stones, form an exhibit of great interest and attractiveness. It shows excellence in quality, designs, and display.

*Rings:* Comprises the exhibits of many manufacturers, and is of the greatest excellence; many thousand rings are admirably displayed. Good taste in arrangement should be carefully noticed; also ex-



Sterling Silver:  $\left\{ \begin{array}{l} 1 \text{ Inch,} - - \$12.00 \text{ per doz.} \\ 1\frac{1}{4} \text{ " } - - 13.50 \text{ " } \\ 1\frac{1}{2} \text{ " } - - 15.00 \text{ " } \end{array} \right.$

AND UPWARDS.

Silver Plate, - - - } \$24.00 per gross,  
Gold Plate, - - - } assorted sizes.  
Black and Oxidized, }



# DEITSCH BROS.,

MAKERS,

7 East 17th Street,  
NEW YORK.

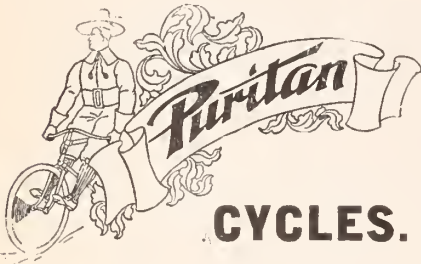

## HIGH GRADE.

Agencies to Jewelers Only.

DISCOUNTS AND CATALOGUE  
ON APPLICATION.

# F. Kroeber Clock Co.,

360 Broadway, New York.

SOLE AGENTS FOR THE  
JEWELRY TRADE.

cellence in quality and designs, finish and the size of the collection.

(Signed) HENRY TILDEN, Individual Judge.

The diploma is signed by H. I. Kimball, President Departmental Committee; John Boyd Thatcher, Chairman Executive Committee of Awards; George R. Davis, Director General; T. W. Palmer, President World's Columbian Commission, and John T. Dickinson, Secretary of the World's Columbian Commission.

### Proceedings of the Philadelphia Horological Society.

PHILADELPHIA, PA., June 8.—The regular monthly meeting of the Philadelphia Horological Society was held Thursday evening, June 4, at its rooms, Bank Hall, Broad St. and Columbia Ave., President Lewis presiding. The Society's meetings are held on the first and third Thursday of each month during the year. The first Thursday is devoted to the reading of essays, answering of the questions that have been deposited in the Question Box and discussions pertaining to the trade. The third Thursday is of a purely social nature, giving the members an opportunity of becoming better acquainted with each other.

After the usual routine business was disposed of, Third Vice-President Brunner took the chair and President Lewis then read a continuation of his paper on "Friction, Lubrication and the Lubricants in Horology." As the time was limited, it was impossible for him to finish the lecture, which will be continued at the July meeting. Alex Kay, of Philadelphia, was elected to membership in the society.

The Society is now entering upon its second year with increased success and has a bright future before it. The organization desires that every watch and clockmaker and storekeeper in the United States and those interested in the betterment and elevation of the trade, should become members. Active membership can be obtained by the payment of \$2.00, or associate membership by the payment of \$1.00, the only difference between the memberships being that an associate member cannot hold office. It will pay the jeweler to join the Society for several reasons. If he lives out of town and meets with a difficult job, or would like to know something concerning the trade, he may write to the secretary and an answer will be promptly sent him. The Society has quite a number of members who stand at the head of the profession and who are well qualified to impart any information pertaining to the practical or theoretical side of the trade. Not of least importance is the effect of membership in the eyes of the public. Nearly every other trade and profession has an organization composed of a majority of its members. Why should not the watchmakers band together and raise the profession in the eyes of the public?

The Society has accepted the generous offer of Geo. K. Hazlitt & Co., Chicago, to publish in book form the copyrighted paper that was read before the society by its president, W. T. Lewis, on "Friction, Lubrication and the

Lubricants in Horology." The book will be a valuable help to all watch and clock makers, as it will be the only book of its kind on the market. It will be on sale in the near future and can be had from the publishers or from the secretary of the Society.

### Edwin F. Kent's Individual Liabilities and Assets.

PROVIDENCE, R. I., June 3.—Stephen O. Edwards, the assignee of Edwin F. Kent, formerly of the Kent & Stanley Co., filed his schedule as assignee yesterday in the Appellate Division of the Supreme Court. This schedule sets forth the assets and liabilities of Mr. Kent as they have been estimated by the assignee. The liabilities are very much in excess of the assets, exceeding them by fully \$170,000. Many of the shares of stock held by Mr. Kent in various companies were considered by the assignee to be valueless and were so rated. The long list of accounts against Mr. Kent is given, amounting to \$190,681.24. The assets are given as follows:

- 1,000 shares Rathbone Mining Co. (par value, \$10,000), no value.
- 100 shares The Portelectric Co. (par value, \$10,000), no value.
- 25 shares Seamless Stock Co. (par value \$2,500), no value.
- 100 preferred shares C. R. Smith Plating Co (par value \$10,000), no value.
- 80 common shares C. R. Smith Plating Co. (par value \$8,000), no value.
- 20 shares Iron Belt Building & Loan Association, Roanoke, Va., \$50.
- Providence Athletic Association, bond, par value, \$100, \$50.
- Equity in real estate, \$7,268 10.
- Claim against Kent-Stanley Co., \$8,000.
- Uncollected rents, \$715.93.
- Equity in 1950 shares of the capital stock of the Kent-Stanley Co., all pledged as collateral, no value.

### Trans-Atlantic Voyagers.

TO EUROPE.

Among the passengers on the *Columbia*, which sailed Thursday, were C. Bühler, New York; Ludwig Nissen, of Ludwig Nissen & Co., New York, and L. Sussfeld, of Sussfeld, Lorsch & Co., New York.

J. R. Mercer, Kansas City, Mo., sailed Wednesday on the *Majestic*.

Among the passengers on the *Lucania*, which sailed Saturday, were S. Frenkel, Toronto, Can.; Mr. and Mrs. Benjamin Kent, Miss Ethel Kent and Miss Lillian Kent, Toronto, Can.; Chas. W. Schumann, New York; Mr. and Mrs. Gus F. Veith, of Oppenheimer Bros. & Veith, New York.

Mr. and Mrs. A. S. Harwood, Boston, Mass., sailed Saturday on *La Bouryogne*.

J. F. Crane, of Mandeville, Carrow & Crane, Newark, N. J., will sail for Europe on the 27th inst.

FROM EUROPE.

Nathan Straus, of L. Straus & Sons, New York, arrived on *La Touraine* last week.

George E. Wilkins and Mrs. Wilkins, Syracuse, N. Y., have returned from a 50 days' trip abroad. They left their daughter at school in Geneva, Switzerland. They traveled through Holland, Belgium, the Rhine country, Switzerland and France.

**Providence.**

*All communications for this column addressed to P. O. Box 1093, Providence, R. I., will receive immediate attention.*

Dexter C. Cheever has removed from 793 Westminster St., to 110 Dexter St.

D. Wilcox & Co. will remove about July 1st to their new building on Washington St.

Cardinal Satolli, escorted by Bishop Harkins, visited the works of the Gorham Mfg. Co., last week.

On Monday a majority of the chain houses of this vicinity started on full time for the first time in two or three months.

Annual repairs have been in progress the past week in the Champlin, Foster & Bailey, Chandler and Briggs & Sons buildings.

Sylvester Eastman is erecting a two story house on Atlantic Ave., and Joseph P. Cory is constructing a new store on Mathewson St.

The Tilden-Thurber Co. will remove to their handsome new building at the corner of Westminster and Mathewson Sts. about July 1.

Charles A. Russell, of Irons & Russell, and Charles H. Fuller, of George H. Fuller & Sons, were two members of a party who recently returned from a fishing and hunting trip in the vicinity of Eustis, Me.

The past week the manufacturing jewelers of this vicinity who had exhibits at the World's Columbian Exposition, received the medals and diplomas that have been so long promised and expected.

Ulysses Racine has mortgaged real estate on Pine St. to the Citizens' Savings Bank, for \$4,500. A previous mortgage of \$1,000 held by the Connecticut Building & Loan Association against this estate, has been discharged.

The What Cheer Pencil Case Co. is the style of a new concern at 95 Pine St., for the manufacture of gold plated and sterling silver pencil cases, pen holders and similar goods. The superintendent of these works is J. F. Ortiz.

The co-partnership heretofore existing between Thomas S. Foster and Samuel A. Bennett, under the style of Foster & Bennett, manufacturers of jewelry, 95 Pine St., has been dissolved. Mr. Foster retires and Mr. Bennett will continue the business at the old stand.

Among the buyers in town the past week were: F. W. Woolman, Cleveland, O.; Eugene M. Stern, S. M. Stern & Co., Philadelphia; A. L. Stone, Stone Bros., Chicago; S. Linz, Dallas, Tex.; George Seelig, Henry Froehlich, and B. Blum, New York; M. Rosengarten, Albany, N. Y.; E. M. Peet, Rochester, N. Y.

Frank W. Crandall, of the manufacturing jewelry concern of Bowes & Crandall, died June 1 after a brief illness with typhoid pneumonia. Mr. Crandall was said to be one of the youngest manufacturing jewelers in the country, being but 28 years old when his promising life was cut short. The deceased was born in this city, and after a common school education entered the stone office of M. D. Rothschild and remained with that concern for a number of years. Later he entered the employ of William R. Richards, as bookkeeper, continuing with their successors, Williams & Payton until 1893, when in

company with Walter Bowes, who had been foreman for Williams & Payton, he started in the manufacturing jewelry business. Mr. Crandall was the traveling member of the concern.

**The Attleboros.**

Richard MacDonald has withdrawn from the firm of Christe, Parker & Co., Wrentham.

C. H. Witherell has returned from a lengthy trip to Maine, where he has been for his health. He is much improved.

The new firm of F. Fonteneau & Co., Attleboro Falls, will be represented on the road this season by Aubrey Cox, formerly traveler for the Mason Jewelry Co.

The entire property of Lincoln, Bacon & Co., Plainville, has been deeded to James D. Lincoln, a former partner of the firm, who, acting as trustee for the benefit of the creditors, will manage the business.

The chain house of J. F. Foley & Co. are out of business after several years' existence. Thomas Hanna is endeavoring to dispose of the property. He was formerly a member of the concern, but upon his withdrawal took a mortgage of \$125, which he has since foreclosed.

Attleboro manufacturers are ready with their new samples. It is generally conceded that there is nothing very decidedly new to offer, but there are certain tendencies that are marked and distinctive. There are few indications in the direction of fads. Most of the jewelers have confined their efforts to regular lines and are showing many samples of their clever designing and careful finish.

The enterprising firm of W. & S. Blackinton are showing a "scorcher" fob chain for wheelmen, a special bicyclist's chain having a spring ring and a bicycle as a charm; another chain with an exact production of a handle bar, a fob with a wheel as a charm, a ladies' chain with a lock and a bracelet with a wheel paddock. In addition to the large line of new patterns always shown by this house, special attention has been given to their King Arthur chains, neck chains and pendants. A new line, consisting of gold stiffened locketts having gold joints and gold rivets, has been added.

Jeweler Linford A. Thomas, Wilmington, Del., and Miss Anna W. Walters were married June 3. After the ceremony Mr. and Mrs. Thomas left for a wedding tour south.

The Only Real  
**UNIVERSAL**  
**CASE.**

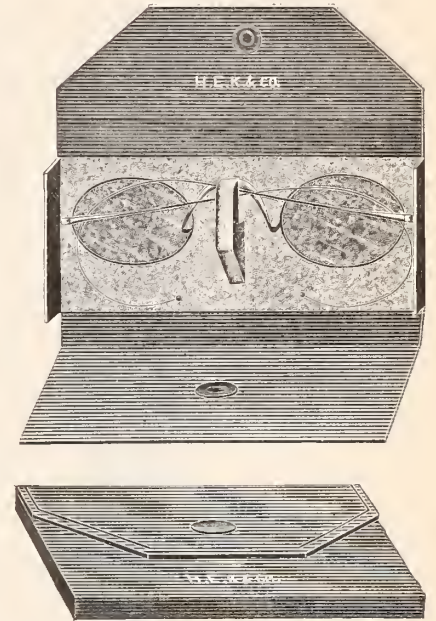

May be used for either  
**Riding Bow Spectacles or**  
**ANY style of Eyeglass.**

ONE great advantage of this case is that one wearing a spectacle and eye glass (or two pairs of spectacles, or two pairs of eye glasses) can be perfectly accommodated with one case—the UNIVERSAL.

SEND \$1.50  
FOR SAMPLE DOZEN.

**H. E. Kirstein & Co.,**  
Rochester, N. Y.

\*\*\*\*\*

**DORFLINGER'S**

**AMERICAN**

**CUT GLASS.**

915 BROADWAY  
36 MURRAY ST.  
NEW YORK.

TRADE  
MARK.

\*\*\*\*\*

# ANNOUNCEMENT



“THE LUXEMBOURG”  
BY  
GORHAM MFG. CO.

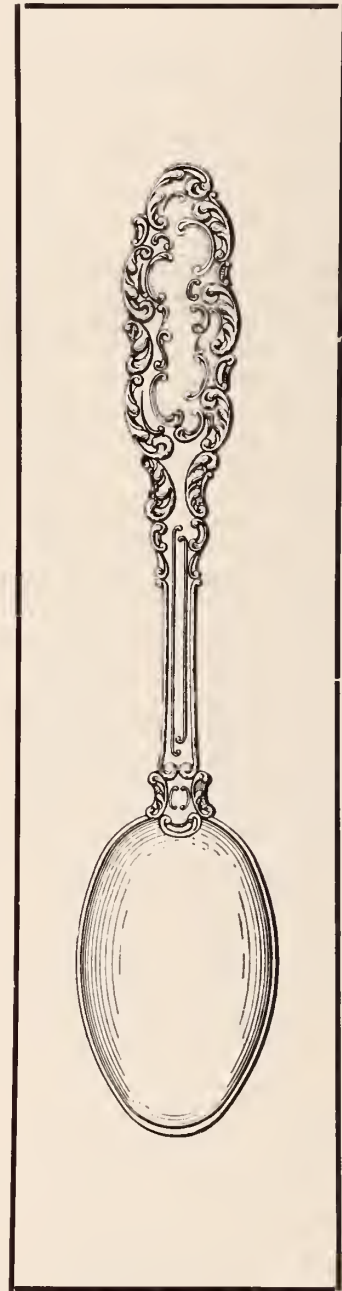

THE  
INFRINGING  
DESIGN.



# TO THE TRADE.

**W**E call your attention to the infringement of our popular "LUXEMBOURG" design for forks and spoons. The popular success of this pattern among the trade and with purchasers of artistic silver ware induced unscrupulous persons to attempt to pirate its leading features.

In order to protect our own interests and the legitimate jewelry trade handling "LUXEMBOURG," and also for the protection of the public against imposition, we brought suit in the United States Circuit Court for the District of Massachusetts against the manufacturers of the infringing pattern which they call "Buonaparte."

The Court, Judge Colt presiding, has recently decided the motion for INJUNCTION in our favor and used, in his opinion, the following emphatic language:

*"Upon the question of infringement I entertain no doubt.*

*"The patent is for a design for the handle of spoons and similar articles, granted to George Wilkinson August 29, 1893. A comparison of the defendants' design with the patented design shows a close imitation.*

*"It is true that upon careful inspection there are certain differences in detail, composition and outline, but these differences are not apparent and would not be observed by the ordinary purchaser, at least until after attention had been called to them. It is sufficient for the purpose determining this motion that, in my opinion, the general resemblance between the two designs would deceive ordinary observers and purchasers, although expert dealers in the trade might at once detect certain differences of detail."*

We also brought suit for infringement against a number of dealers through whom this unlawful pattern was placed upon the market by the manufacturers. In fact, against every dealer where we were able to obtain proof. We shall pursue this policy so that our customers may be assured of complete protection in the use of our "LUXEMBOURG."

In connection with the above, we desire to call the attention of the jewelry trade to the fact that this infringing pattern was brought out for the Dry Goods dealers who, being unable to obtain our "LUXEMBOURG" and finding that the great and popular demand for the "LUXEMBOURG" could not be satisfied by any of the patterns which these Dry Goods stores were able to obtain, they planned to have this infringing pattern made, and they found manufacturers who, with little sense of honor, were willing to make it for them. Unfortunately for these manufacturers, they produced a pattern so clearly a copy that Judge Colt's emphatic decision upon the question of infringement will doubtless be followed by all future authorities.

 **Gorham Mfg. Co.,**  
Silversmiths,  
Broadway and 19th Street.

### The St. Louis Trade Resuming its Normal Condition.

St. Louis, Mo., June 6.—Business is resuming its normal condition after the calamity of last week. The wreckage is being cleared up and people are getting to look more calmly at the disaster. The losses in many cases were over-estimated, though it is perfectly safe to say the tornado cost the city and its inhabitants fully \$20,000,000.

The following notice has been sent out by the Retail Jewelers' Association, of Missouri:  
St. Louis, Mo., June 3, 1896.

Dear Sir:—A terrible calamity has struck this city, and we would like to ascertain if any jewelers, watchmakers or employees of the trade are among the unfortunate sufferers. We would be pleased if you would report to this association any case of want, so that this association can help them out of our special fund. Respectfully  
R. J. A. of M.,  
F. W. BAIER,  
Secretary, 318 N. 4th St.

The Jewelers' Committee appointed to raise funds for the tornado sufferers reported on Friday almost \$800 raised. Among the contributors were: Mermod & Jaccard Jewelry Co., \$150; E. Jaccard Jewelry Co., \$150; J. Bolland Jewelry Co., \$50; L. Bauman Jewelry Co., \$50; H. Hirschberg Optical Co., \$10; Erker Bros. Optical Co., \$25; J. C. McCoy, \$5; A. R. Brooks, \$5; J. W. Cary & Co., \$10; F. W. Baier, \$10; Bauman-Massa Jewelers' Supply Co., \$25; St. Louis Clock & Silverware Co., \$25; Providence Jewelry Co., \$5; A. Kurtzborn & Sons, \$50; E. H. Kortkamp Jewelry Co., \$25; Herman Mauch, \$10; the Lowenstein Jewelry Co., \$10; J. Lowenstein, \$10; C. R. Hettel Jewelry Co., \$10; Zerweck Bros., \$10; M. Morris, \$10; R. Haberman, \$5; Bierbaum & Bohle, \$10; S. A. Rider Jewelry Co., \$25; W. A. Gill, \$10.

Among the contributors who gave substantial amounts unsolicited may be mentioned Keller, Ettinger & Fink and Zack Oppenheimer, both of New York.

M. Eisenstadt Jewelry Co. gave quite a sum of money to several of their employes who lost their property in the storm.

Several of the jewelers on South Broadway, who were affected, and of whom mention was made last week in THE CIRCULAR are doing business with wire screens instead of plate glass in their windows, it being impossible in the rush to get all the broken panes repaired.

The Shepard School gave a picnic on the 6th inst. Herman Mauch is secretary of the committee of arrangements, and they have decided to donate the proceeds to the Public School Relief Fund, many of the schools having suffered severely in the tornado.

In addition to the long list of casualties in the trade published in THE CIRCULAR last week, were the following:

Boos & Des Voignes, 1221 S. Broadway, were damaged to the extent of \$400.

Frederick Halter, 2010 S. Jefferson Ave. was right in the "cyclone district" but his damage is only placed at \$60.

A. L. Steinmeyer, of the E. Jaccard Jewelry Co., owned some tenement houses at Rutger

and 3d Sts., which were damaged to the extent of \$3,200. Mr. Steinmeyer took his loss philosophically and it is characteristic of this disaster that every one seems not to be thinking of dollars and cents, but merely how to help along their suffering fellow-men.

F. J. Tomek, 1411 S. Broadway, was damaged to the extent of \$250.

Philip Frech, of the Phil. Frech Watch and Jewelry Co., lived in the storm district at 2119 S. Jefferson Ave. His loss on household effects will foot up \$200.

A. Kuhn & Co.'s store, 1748 Chouteau Ave., was considerably damaged. The roof of the building was blown off, and much of the stock rendered unsalable.

Pelton Bros. Silver Plate Co., 717 S. 6th St., suffered severely. The loss on stock amounted to \$1,500. The building, which is owned by O. Z. Pelton, was damaged in the sum of \$3,000. A number of girls worked here, but they were all congregated in the office during the storm, and notwithstanding some of them became almost hysterical, they were all kept under control and nobody was injured.

The residence of Edward C. Zerweck, of Zerweck Bros., 2620 Allen Ave., was badly damaged, and to make matters worse Mr. Zerweck was in bed ill at the time. Fortunately he was on the first floor, as all above it was carried away by the wind. The damage to furniture, etc., will amount to \$400 or \$500.

### Death of James H. Dederick.

James Herman Dederick, surviving partner of Dederick & Co., 18 Maiden Lane, New York, died suddenly Sunday night, at his home in Bayonne, N. J. Death is supposed to have been caused by heart failure due to old age.

Mr. Dederick was one of the oldest smelters and refiners in the jewelry trade, having started in that business about 45 years ago. He was born at Catskill, N. Y., in March, 1815. From the time he was a young man he was connected with the jewelry trade in various lines and about 1850 formed the firm of Dederick, Sears & Co., refiners, who were succeeded by Dederick & Co., composed of J. H. Dederick and Zachariah Dederick. Since his brother's death, a year or so ago, James H. Dederick continued alone. He was well known throughout the entire jewelry trade and leaves many friends who mourn his loss.

### Death of Joseph H. Washburn.

NATICK, Mass., June 5.—Joseph Hills Washburn, jeweler, died at his home in S. Main St., a few days ago of dementis. He was born in Hancock, N. H., June 10, 1829. He was graduated from Peterboro academy, learned watchmaking and engaged in the jewelry business in Roxbury and Chicopee until 1855 when he went to Michigan. Returning he became inspector at the Tremont watch factory in Boston, whence he came to Natick. He was a generous giver to charities. A wife and a son survive him.

### The American Watch Co. not yet prepared to make a Statement.

Boston, Mass., June 6.—A. V. Huyler, of N. H. White & Co., and E. S. Smith, of Smith & North, New York, are the authors of a circular sent out from the proposed Jobbers Association organization committee, and it is stated that one of the committee has been in Boston this week obtaining signatures to the call for the convention. Of the score or more handlers of watches in jobbing lots in this city nearly all have signed this call.

Royal Robbins, of the American Waltham Watch Co., when asked whether that company would be in the agreement, said that only the outline of the project had been submitted to him. In advance of the convention he was not prepared to make any statement. Consideration of the matter would have to come before the directors as a whole, and as president E. C. Fitch is now on a vacation, nothing would be done about it officially before his return, and probably not before the factory vacation is over, early in August.

### Kind Words Regarding "The Circular."

TORONTO, April 20, 1896.

Paper is well worth the money.

EDMUND SCHEUER.

CAMBRIDGE, May 25th, 1896.

I look for the arrival of THE CIRCULAR with longing eyes. No sheet I have ever seen contains so much practical information as THE CIRCULAR. Yours for prosperity,

H. E. WHEELER.

CARROLLTON, OHIO.

I send to you this day, check for \$2. Kindly continue THE CIRCULAR for another year, as I am well pleased with same.

F. P. BOEGEL.

SAGINAW, E. S. MICH., Apr. 23, '96.

Enclosed find the check \$2.00 to pay enclosed bill which please receipt and return. THE CIRCULAR is a fine trade paper and does lots for the jeweler.

BROWN & GRANT.

MERCED, CAL., May 1st, 1896.

Enclosed find check for \$4.00 covering subscription to Jan. 24th, '96. "A Good Paper."

C. H. LEGGETT.

WILLMANTIC, CONN., May 2nd, '96.

Can hardly afford to do without paper. Enclosed find check for enclosed bill and oblige.

J. H. TRACY.

CATALANI'S JEWELS.

Catalani, like most prima donnas, had a great weakness for showing off her jewelry.

"You see dis brooch?" she would say: "de Emperor of Austria gave me dis. You see dese earrings? De Emperor of Russia gave me dese. You see dis ring? De Emperor Napoleon gave me dis," and so on.

Braham, the tenor, in imitation of this, would say, pointing to his umbrella:

"You see dis? De Emperor of China gave me dis." Then pointing to his teeth, "De Emperor of Tuscany gave me dese."—*San Francisco Argonaut.*



# The Jewelers' Circular

AND  
HOROLOGICAL REVIEW.

PUBLISHED EVERY WEDNESDAY BY

THE JEWELERS' CIRCULAR PUB'G CO.,

189 BROADWAY, NEW YORK CITY.

A JOURNAL DEVOTED TO THE INTERESTS OF JEWELERS, WATCHMAKERS, SILVERSMITHS, ELECTRO-PLATE MANUFACTURERS, AND ALL ENGAGED IN KINDRED BRANCHES OF INDUSTRY.

Member of the American Trade Press Association.

Our Editorial columns will contain our own opinions only, and we shall present in other columns only what we consider of interest or value to our readers. Advertising matter will not be printed as news.

Advertising rates in THE CIRCULAR are lower, considering the number of tradesmen reached by its large circulation, than in any other jewelry journal.

Notices of changes in standing advertisements must be received one week in advance; new matter can be received up to Monday.

## INFORMATION FOR SUBSCRIBERS.

### Terms of Subscription, Postage Prepaid.

United States and Canada, - - -	PER ANNUM.	\$2.00
Foreign Countries in Postal Union, - - -		4.00
Single Copies, - - - - -		.10

New Subscribers can commence at any time.

Payments for THE CIRCULAR when sent by mail, should be made in a Post-Office Money Order, Bank Check or Draft, or an Express Money Order or Registered Letter. All postmasters are required to register letters whenever requested to do so.

Pay money only to authorized collectors having proper credentials.

**Returning Copies:** Returning your paper will not enable us to discontinue it, as we cannot find your name on our books unless your address is given.

**Changing Address.** In changing address always give the old as well as the new one. Your name cannot be found on our books unless this is done.

**Discontinuances.** We will continue to send papers until there is a specific order to stop, in connection with which all arrearages must be paid; but such an order can be given at any time, to take effect at or after the expiration of the subscription. All such orders will be promptly acknowledged by mail.

**Liability.** The Courts have decided that all subscribers to Journals are responsible until arrearages are paid in full and an order to discontinue has been received by the publisher.

## THE JEWELERS' CIRCULAR IN EUROPE.

Among the Places in Europe where THE JEWELERS' CIRCULAR is on file are the following:

**LONDON**—First Ave. Hotel, Holborn, E. C.; Holborn Viaduct Hotel, Royal Hotel.

**PARIS**—Hotel de L'Athénée, Rue Seribe.

**BERLIN**—Deutsche Uhrmacher Zeitung, Jager-Strasse, 73.

**GENEVA**—Journal Suisse D'Horlogerie.

**AMSTERDAM**—Continental Club, Hotel Amstel.

**ANTWERP**—Diamond Club, Rue de Pelican.

Vol. XXXII. June 10, 1896. No. 19.

Every line of reading matter in THE JEWELERS' CIRCULAR, with the exception of the few brief extracts from exchanges, always properly credited, is written exclusively for this journal. Each issue of THE JEWELERS' CIRCULAR is copyrighted. Permission to quote is extended to other publications if such quotations are properly credited.

THE large attendance at the convention last week of the Optical Society of the State of New York, the long established reputation as opticians of many of the attending members, and the high scientific character of the several addresses made before the assemblage should warrant a favorable hearing by the New York Legislature on the application for the passage of a bill incorporating the organization, when next it is presented before that body.

IT is from time to time desirable to say in this page that the columns of THE CIRCULAR are open for the expression of opinions by any member of the trade, provided his communication is signed with his name, or his name, in some manner, is made known to the editor. However, while space is afforded such communications, it does not necessarily follow that we coincide with the opinions or endorse the statements given in them.

A NEW tariff question has been raised in the case of the return to this country from London of the diamonds stolen from the Burden family, of New York. The gems, under the law, have been re-imported into the United States and are liable to duty. It seems an injustice that the Burdens, through no fault of their own, should lose \$17,000, as they will do, if the Treasury Department decides that the diamonds are dutiable. However, should the gems get through the custom house without payment of duty, and should the case serve as a precedent, it is a question whether, in the future, some gigantic scheme of smuggling could not be concocted, based upon a hatched-up robbery.

### The Horological Trade In America.

WE are not evincing a lack of patriotism when we say that America is far behind the countries of Europe in the importance of its organizations for the advancement of art, science, and the various departments of thought. The sentiment of patriotism will not urge us to claim that the United States have any organizations equaling in compass and power the different Royal societies of Great Britain, such as the Royal Academy, the Royal Geographical Society, and the Royal Society of Antiquaries, or the French Academy and the Society of Beaux Arts, of France. For the advancement of industry in some of its branches, such as electrical appliances and machinery, the United States can boast of several influential bodies, as the National Electric Light Association and the Society of Electrical Engineers; but in the minor industries few societies exist of so comprehensive and powerful a character as their counterparts in the older countries. Notably is this so in the horological industry. Switzerland, England, France and Germany possess organizations whose proceedings are followed with keen interest by all watch manufacturers, dealers and repairers, and whose promulgations carry great weight. The reports of the Swiss Horological Society and of the British Horological Society

have lasting effects upon the entire watchmaking industry of the respective countries. These institutions tend to maintain horology in its place among the highest of applied sciences, and the watchmaker in his position as a person of scientific skill and ingenuity. It is to only once more reiterate an often expressed assertion, that the United States require some institution which will prevent the ancient and delicate craft of watchmaking from degenerating into a skillless avocation, which has seemed to be its fate for several years past. The founding of the Philadelphia Horological Society was a step in the right direction, and it is gratifying to learn from its officers that some measure of success has already been attained. However, there is yet an extensive field for the expansion of its influence, which can be fulfilled only by a large increase in its membership. It appears to us that no watchmaker should require any arguments to urge him to have his name enrolled as a member of this society. Its nominal cost would be many times compensated for in the good effect upon his business that the announcement to his public that he is a member of a recognized body of horologists would create. We think that any mechanician should be anxious that his knowledge of his craft be as full and complete as possible. Membership in an organization which disseminates valuable information, as does the Philadelphia Horological Society, will tend to achieve this end. Every circumstance, even the egotistic desire for self success, should urge the watchmaker to become a member of this society. The advancement and betterment of the horological trade generally means the advancement and betterment of the watchmaker individually.

### Are Diamonds Stolen in America and Returned from Europe Dutiable?

WASHINGTON, D. C., June 6.—The Treasury Department has under consideration the question of compelling the Burdens to pay duty on their stolen diamonds. This question will not be settled until after the trial, when evidence has been secured to identify the stones. But even with identification the investigation of the authorities is not at all certain to end. The diamonds under the law have been reimported into the United States and are liable to duty.

Treasury experts recognize that an injustice would be done to the Burdens if they were required to pay duty, as the stones were stolen and returned to this country with the thieves. The law must be looked into, however, they say, before the diamonds can be turned over to their rightful owners. Secretary Carlisle informed Collector Kilbreth that he could lend the Burden diamonds to the State to be used as evidence at the trial of the robbers, but that he could not release them until it was determined whether they were dutiable.

COLUMBUS, GA., May 14th, 1896.

Please find enclosed money order to renew my subscription to THE CIRCULAR. Can't do without it.  
C. M. KINSEL.

### New York Notes.

Jules Racine & Co. have filed a judgment for \$70.85 against Herman Harris.

A judgment against Julius Freudenheim for \$203.45 has been entered by L. Hirsch.

A judgment against Chas. Kuhn, Jr., Geo. Doerflinger and Frederic Storm, for \$3,141.04 has been filed by Frederick Beltz.

A judgment for \$1,274.32 against the Meriden Britannia Co., A. H. Page and J. H. Ringot, has been entered by G. W. Stephens, as receiver.

The Pairpoint Mfg. Co. showed in their window, 46 Murray St., last week, the prizes to be awarded at the Bicycle Concert and Carnival, which opened Saturday at the Madison Square Garden.

Mrs. Emily A. Hart, daughter of Henry Randel, of Randel, Baremore & Billings, was married June 2d to H. H. Rogers, vice-president of the Standard Oil Co. The ceremony took place at the residence of Mr. Randel, 38 E. 38th St.

John Konvalinka, a dealer in furs who has occupied the store at 36 Maiden Lane for many years, and who was well known in the jewelry district, died Wednesday at his residence 208 Park Place, Brooklyn. He was 74 years old.

E. L. Anrich, Friday, entered judgments against the following: Berl Bonner for \$2,394.86; Morris Damash for \$45.71; M. Flengelman for \$122.28; Simon Glanz for \$164.60; E. M. Pilzer for \$778.78; and Elias Pitzele for \$102.60.

A decision of the Appellate Division of the Supreme Court, handed down Friday, reverses the judgment for \$500 obtained by Jos. Kleb against Wallach & Schiele, and orders a new trial of the action. The suit was over a disputed claim for the use of certain designs for jewelry.

Metzger Model Mfg. Co., of New York city, have been incorporated to manufacture and sell plush and silverware and jewelry cases and boxes, etc. The capital is \$5,000. Louise A. Metzger and Charles F. Metzger, of Brooklyn, and C. E. Metzger, of New York city, are the directors.

Henry Baremore Billings, the son of Chester Billings, of Randel, Baremore & Billings, was married Thursday to Laura Van Court Ross, daughter of P. Sanford Ross, Newark, N. J. The ceremony was performed by the Rev. Lyman Whitney Allen at the South Park Presbyterian Church, Newark.

The prize contest in declamation by the freshman class, Williams College, which took place Wednesday evening, June 3, 1896, was won by J. Mandly Hills, Brooklyn, the son of James E. Hills, New York representative of Horton, Angell & Co. and A. Bushee & Co. Mr. Hills was the closing speaker and won the first prize.

The five suits brought by the United States against M. S. and J. S. Von Wezel, to recover \$1,000 each, for diamond workers alleged to have been brought from Europe in violation of the Contract Labor Law, were on the calendar of the United States Circuit Court

last week, but have been allowed to go over until Fall.

In the Yorkville Police Court Wednesday, Michael Enright, of 693 E. 185th St. and James Regan, 341 E. 75th St., were prisoners charged with selling brass watches for gold. They sold to a German an alleged gold watch for \$6, and were taken into custody. The complainant would not appear against them, and each was fined \$10 for disorderly conduct.

A limited partnership to be known as Haviland & Abbot has been formed by Frederick Haviland, Edgar W. Abbot and Mary M. Gager, to commence July 1, 1896, and terminate Dec. 31, 1899. The general partners are Fred, Haviland and E. W. Abbot and the special partner is Mary M. Gager, who contributes \$25,000. The firm will continue the business of importing china, bronzes, etc., heretofore conducted by O. A. Gager & Co. and their successors, Haviland & Abbot.

While a carboy of strong nitric acid was being hoisted to the third floor of 90 Mechanic St. Newark, Thursday, the rope sling slipped and the carboy fell to the second floor and broke. Charles Cory, an employe of A. J. Hedges & Co., manufacturing jewelers, who was superintending the hoisting, was drenched with the acid and badly burned. An ambulance was summoned and Cory was removed to St. Barnabas Hospital. He was frenzied with pain, but it was thought that his burns were not necessarily mortal injuries. Cory is 39 years old and has a wife and family.

Deitsch Bros., manufacturer of leather, ebony, ivory, and tortoise shell goods, silver novelties, etc., 7 E. 17th St., have purchased the premises, 25x100 feet, at 14 E. 17th St. The present structure on this site will be removed and in its place Deitsch Bros. will erect an eight-story fire-proof building which will be fitted up with factory and offices especially for the use of manufacturing jewelers. The building will occupy the entire depth of the lot and will have all modern conveniences, including electric lights, elevator, steam heat, and steam power. The building, it is expected, will be ready for occupancy by May 1st, 1897.

Henry Hayes, President of the Jewelers' League, is to be married to-day in Binghamton, N. Y., to Miss L. M. Allen, of that city. The ceremony will be performed at the residence of the bride's mother. Mr. and Mrs. Hayes will sail for Europe on their wedding trip. Among the many wedding presents is a beautiful real bronze figure, *Mussée du Bois*, by Eugene Maudon, which was presented by the officers and executive committee of the Jewelers' League. The figure is about 28 inches high, and was accompanied by an onyx pedestal. Another beautiful present which has been sent to Mr. and Mrs. Hayes is a beautiful silver service presented by members of the Jewelers' Safety Fund Society, of which Mr. Hayes has been president for 10 years. The set consists of five pieces, and is one of the finest obtainable from Tiffany & Co. Nearly all the New York members of the Jewelers' Safety Fund

Society are among the subscribers for this present.

Some time ago 19 diamonds brought over from Antwerp on May 12th, by B. Schlessinger, were seized by customs officers, because it was discovered that they were worth 6,000f, instead of 1,000f, at which they were entered. Collector Kilbreth was recently informed that the diamonds belonged to H. Bernwald, a diamond merchant, at Antwerp, and that they had been carried off without his knowledge. Chas. Mali, the Belgian Consul in this city, also notified the Collector that Mr. Schlessinger, of Antwerp, had arrived in New York with a package containing diamonds worth 6,000f, and that he was informed that the diamonds belonged to somebody else, and he asked that they be detained until he heard further from the Belgian government. When Schlessinger called at the Appraiser's Stores to get the diamonds he was told that somebody else claimed them. It is understood that the case has been called to the attention of the United States District Attorney MacFarland.

### Proceedings of the Jewelers' League.

The regular monthly meeting of the executive committee of the Jewelers' League was held on Friday, June 5th. There were present Vice-Presidents Bowden, Bardel, Greason, Chairman Van Deventer, Messrs. Kursch, Street and Fessenden and L. Stevens, Jr., secretary. The minutes of the previous meeting were read and approved. Nine requests for charge of beneficiary were received and upon motion granted and the following applicants were admitted to membership:

Sec. A:—Henry E. Hall, San Francisco, Cal., recommended by G. M. Van Deventer and D. Untermeyer; A. Livingston, New York city, recommended by E. Livingston and L. Stevens, Jr.; W. E. Dowd, New York city, recommended by C. E. Bulkeley and F. S. Salisbury; Chas. H. Hoadley, Providence, R. I., recommended by T. W. Manchester and A. L. Ambony.

The next meeting will be held July 3rd, 1896.

The suit of W. J. Stone against Charles S. Bell, arising out of differences in the settlement of the jewelry firm of Stone & Bell, Ypsilanti, Mich., has been discontinued. Bell paid Stone \$210.

Rudolph Schmidt, optician, Rochester, N. Y., has secured the electric clock contract for the new Monroe County court-house at \$980; also the contract for an indoor telephone system for the same building at \$420.

H. Rife, a traveling jeweler, was arrested May 27, in San Jose, Cal., on complaint of the station agent at Templeton, on a charge of attempting to extort \$50 from the Southern Pacific Co. He claimed that his trunk had been broken into on the train between San Luis Obispo and Templeton and demanded \$50, which the railroad company refused to pay, as they were satisfied that Rife's story was not true. He was taken to Templeton.

DEPARTMENT OF  
**ADVICE AND CRITICISM**  
 ON  
**RETAIL JEWELERS' ADVERTISING.**

BY ALFRED MEYER.

[This department is absolutely free to every retail jeweler and optician. Forward for criticism your newspaper ads., booklets, catalogues, novelties, circulars, etc. Ask advice and offer suggestions. Replies in these columns are unbiased. Please make letters as brief as possible. Every letter and ad. sent will receive full attention, though the publication of the matter may sometimes be delayed a week or two. Address letters and other matters to The Jewelers' Circular Pub. Co., 189 Broadway, New York.]

PART XVI.

FOR the jewelry store opening of G. A. Spies, Irwin, Pa., a four-leaf zig-zag edge "greeting" was gotten out. The front page was embossed. Its purpose was to invite people to the "grand opening" and acquaint them with the fact that besides a display of diamonds, gold watches, etc., there would be a beautiful gold watch and chain given to the person making the most trips to and purchases at the store on the opening days. That this "greeting leaflet" was an effective, good advertisement, is proven by the fact that the winner of the watch and chain made 23 purchases.

\* \* \*

Dan S. Jones, jeweler, Independence, Ia., sent a newspaper with one of his 5-inch double-column ads. in it. With the dis-

The public are becoming wiser daily. They are beginning not to believe that every jeweler or other merchant can afford to give "big values at little prices." Therefore it is by all means necessary—when quoting an article with description and price—to give the reason for its cheapness. It is anything but good policy to quote everything you have for sale in one ad. Mr. Jones could have made two good business-bringing ads. out of his one ad. The one should have been started with "Beauty in Gold, Silver and Glass," and the other with "50 second-hand watches in good order." However, Mr. Jones is a good ad. writer, but he lacks the knowledge necessary to convince customers to buy immediately. Mr. Jones and others should always put themselves, when writ-

of the ad. lies in the manner the tale is told about the knives, the way it acquaints the reader with

**JEWELERS**  
**NEED**  
**ANY**  
**KNIVES?**

Let us call your attention to our special triple silver plated Knives and Forks. These goods are made for us by the largest silverware factory in this country. The Knives are plated on the best of steel and the Forks on hard white metal. Every piece has our name stamped on it, and we guarantee them to wear to the entire satisfaction of the purchaser. Liberal, don't you think? Notice the low price we now name, \$1.85 per set of six pieces (illustration three-fourths size.)

CUT  
 OF  
 KNIFE.

Truby's,  
 Independence,  
 Kansas.  
 Mail  
 orders  
 promptly  
 filled.

**OPTICIANS**

the fact that the set of 6 pieces, as per illustration, can be bought for \$1.85. The ad. is written convincingly, so that it will urge the reader to buy; an ad. should not be expected to do more. Were I in Independence, Kan., and had I read the ad., I should have replied to it; and if the goods were as described, certainly should have bought.

\* \* \*

This ad. of the Mermod & Jaccard Jewelry Co., St. Louis, Mo., occupying one inch of space, is very good. However, it is not good policy to say "\$5 and up," nor any other price and up, because the average person may misunderstand you, may surmise that the price quoted is but a bait, and that

he will be forced into buying

**WE WILL  
 TEST YOUR  
 EYES FREE!**

And if you don't require Glasses, will tell you so. You cannot afford to take any chances. Gold Frame Glasses, \$5 up. Steel Frames, \$1 up. Mail orders filled. Send for test card.

**MERMOD & JACCARD'S,**  
 Broadway, cor. Locust.

something for much more money. The best thing to do is to advertise an article at a definite popular price. This will make people call at the store, and the ad. has therefore done its duty. The salesman must complete the work, namely, make the sale.

\* \* \*

From a Los Angeles, Cal., paper I clipped this ad. of Lissner & Co.

LOS ANGELES, CAL.

**Becoming  
 Glasses....**

*How many opticians in fitting glasses select the style of frame that is most becoming to each individual? Our opticians, while giving glasses and frames that are perfectly comfortable to the eye as well as to the face, always choose or advise the style that will look the best. We offer expert service in the filling of Oculists' prescriptions.*

**LISSNER & CO.,**  
 Opticians,  
 South Spring Street,  
 Broadway and 13th St., Oakland.

All but lacking the prices and descriptions of the glasses, it is a good, convincing ad. The display is very good.

\* \* \*

This ad. of Whitney, jeweler, Clinton, Ia., is well displayed.

CLINTON, IA.

**The Wedding Ring.**

That magic Circle that binds two hearts in one and fills the world with conjugal Felicity.

**Diamond Solitaire Rings.**

They do say our rings are a talisman of good fortune. Get acquainted with our rings.

**WHITNEY,**  
**THE JEWELER,**  
**18 HIGH STREET.**

It needs, like most jewelry ads. all over the country, the addition of articles with prices, to make it a good, business-bringing announcement.

**Beauty in Gold,  
 Silver and Glass,**

as in all other articles, depends in the artistic taste displayed in the manufacture. No matter what beautiful or precious metals may be used in the manufacture, if the artistic taste is lacking, there is no beauty in the result. We have always borne this fact in mind in the selection of our goods, and the result is that the artistic element enters into even our most inexpensive pieces of Jewelry, Silverware and Cut Glass. We are giving

**Big Values at  
 Little Prices**

*In Gold Watches, Silverware, Clocks, Rings and Cut Glass. Watch our show window for new things. We have in good repair 50 Second Hand Watches that we will sell very cheap to close out.*

**Dan S. Jones,**  
 Repairing. The Jeweler.

play and border of the ad. I cannot find fault.

The ad. itself contains too much matter, more than one idea. Mr. Jones should have stopped the ad. at "we are giving big values at little prices;" or he should rather have added one or more items, each with description and price; one item each of jewelry, silverware and cut glass. No doubt the ad. would then have brought considerably more business than it did.

ing an ad., in the places of "bargain hunters" for jewelry. Continually writing ads. as they are seen with the eyes of a customer will put Mr. Jones in a position to construct some very effective advertisements.

\* \* \*

This is about as good an ad. as I have ever seen written about knives.

The border is attractive. The ad. in itself is sincere, and written in an honest strain. The beauty



**WE HAVE  
ON HAND**

A Large Number of Small

## Advertising Cuts

Specially Designed for JEWELERS' ADVERTISING, such as above, at

75 Cents per Electrotpe.



SEND FOR PROOF SHEET.



THE JEWELERS' CIRCULAR PUB. CO.,

189 Broadway, New York.

## Business=bringing retail jewelry ads.

by the year, at \$5 per week.

I will not do this work for more than **one** reliable jeweler in a town.

Each jeweler who accepts my services gets this agreement from me.

Gentlemen:—

I have accepted your offer to write your newspaper advertisements for one (1) year from date, for the sum of two hundred and sixty (\$260) dollars yearly—payable in instalments of five (\$5) dollars per week, Saturdays.

You to be the only jewelry house I shall write newspaper advertisements for in the city of . . . . .

This includes advice on all matters in advertising and store management, and the placing of all of the advertisements.

You are privileged to cancel this agreement at any time, by paying for time in force at the rate of ten (\$10) dollars per week.

Very truly yours,

ALFRED MEYER,

P. O. Box 2254,

New York.

### The Latest Patents.

ISSUE OF JUNE 2, 1896.

**561,316.** WORKMAN'S TIME-RECORDER. DANIEL HEPP, (Chicago, Ill.—Filed Apr. 23, 1895. Serial No. 546,859 (No model.)

**561,383** TELESCOPIC SIGHT. BRADLEY A. FISKE, U. S. NAVY.—Filed May 29, 1893. Serial No. 474,872. (No model.)

**561,431.** STAMP-HOLDER AND MATCH-



SAFE. CONRAD PRAGER, Etna, Pa.—Filed Feb. 12, 1896. Serial No. 578,994. (No model.)

In combination, an outer receptacle or box provided with a hinged cover and having an inner wall on each side, a slide adapted to fit between the walls, and having longitudinal flanges, and a spring for operating the cover.

DESIGN 25,553. BADGE. LEWIS A. BROWN, St. Louis, Mo.—Filed March 30, 1896. Serial No. 585,493. Term of patent 3½ years.

DESIGN 25,554. BADGE. JOSEPH S. BLINN, New Haven, Conn., assignor of the Scovill Manufac-



turing Co., Waterbury, Conn.—Filed Apr. 27, 1896. Serial No. 589,325. Term of patent 3½ years.

DESIGNS 25,555 AND 25,556. BADGES. JOHN J.

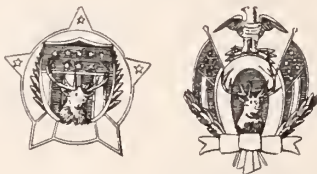

GLIN, Lowell, Mass.—Filed Feb. 24, 1896. Serial Nos. 580,583 and 580,584. Term of patents 7 years.

DESIGN 25,557. WATCH-CHAIN. FREDERIC E. STURDY, Attleborough, Mass., assignor to J. F. Sturdy's Sons, same place.—Filed Apr. 9, 1896.



Serial No. 586,978. Term of patent 7 years.

DESIGN 25,558. SPOON, &C. PIERRE B. NOYES, Niagara Falls, N. Y., assignor to the Oneida Com-



munity, Limited, Kenwood, N. Y.—Filed Apr. 25, 1896. Serial No. 589,130. Term of patent 3½ years.

DESIGN 25,559. SPOON HANDLE, &C. CHARLES ORBORSE, New York, N. Y., assignor to the

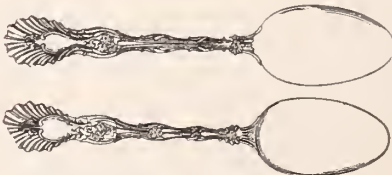

Whiting Manufacturing Company, same place.—Filed Apr. 30, 1896. Serial No. 589,779. Term of patent 7 years.

DESIGN 25,568. BRUSH BACK OR SIMILAR ARTICLE. HENRY A. WEHMAN, Philadelphia, Pa.—Filed Aug. 30, 1895. Serial No. 861,041. Term of patent 3½ years.



DESIGN 25,570. GLASS DISH. WILLIAM C. ANDERSON, Toledo, Ohio, assignor to the Libbey Glass

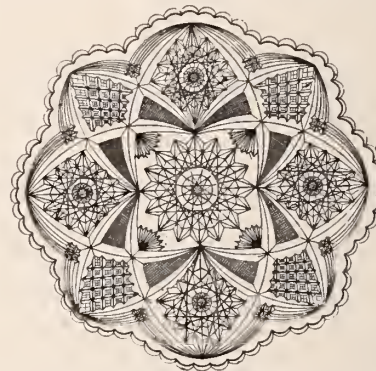

Company, same place.—Filed March 19, 1896. Serial No. 583,982. Term of patent 7 years.

DESIGN 25,575. CASE OR BOX. EDWIN JOHN FLETCHER, New York, N. Y., assignor to the

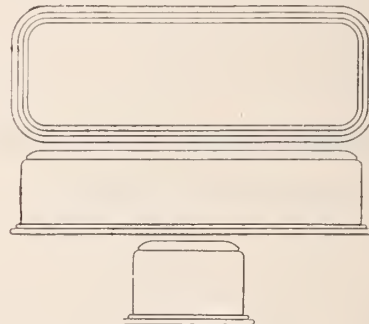

Whiting Manufacturing Company, same place.—Filed April 8, 1896. Serial No. 586,755. Term of patent 7 years.

DESIGN 25,576. CASE OR BOX. EDWIN JOHN FLETCHER, New York, N. Y., assignor to the

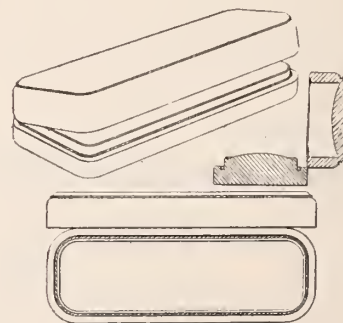

Whiting Manufacturing Company, same place.—Filed April 8, 1896. Serial No. 586,756. Term of patent 7 years.

TRADEMARK 28,321. PINS, JEWELRY AND BLJOUTERIE. DAVID N. COOK, Salem, Mass.—Filed April 29, 1895.

## FIRST CHURCH.

Essential Feature.—The words "FIRST CHURCH." Used since April 1, 1896.

## Special Notices.

Rates 75c. per insertion for notices not exceeding 3 lines (25 words); additional words 2 cents each. If answers are to be forwarded, postage stamps must be enclosed. Two insertions, 15 per cent. off; three insertions, 20 per cent. off; four insertions or more, 25 per cent. off. Payable strictly in advance. Display cards on this page will be charged at \$2.00 per inch for first insertion, subject to same discount as above for subsequent insertions.

Under the heading of **Situations Wanted** on this page advertisements will be inserted for One Cent a Word each insertion, no discount. This offer refers to **Situations Wanted only**. Payable strictly in advance. If answers are to be forwarded, postage must be enclosed.

## Situations Wanted.

Notices under this heading **ONLY** are charged at one cent a word, payable strictly in advance. If answer are to be forwarded, postage must be enclosed.

**FIRST-CLASS LAPIDARY** with tools and benches is open for engagement. Address T. W. G., care JEWELERS' CIRCULAR.

**FIRST-CLASS WATCHMAKER**; best of references, desires permanent position in or near New York. Address R. H. W., care JEWELERS' CIRCULAR.

**WATCHMAKER** would like position with a reliable house; 15 years' experience on fine and complicated work; full set of tools. Address Elgin, care JEWELERS' CIRCULAR.

**WANTED AT ONCE**, position by first class watchmaker and engraver; good jewelry repairer; own tools; salary, \$15 per week; best references furnished. Address H. C. Morey, 215 Newcastle St., Brunswick, Ga.

**POSITION** by young man 24 years of age, several years' experience in jewelry business; salesman and general repairer; open until Sept. 15th; sober and practical; best of references. Address W. B. W., care JEWELERS' CIRCULAR.

## Help Wanted.

**WANTED.**—Experienced traveling salesman to handle best American line of spectacles through New York State and the East. Address Optics, care JEWELERS' CIRCULAR.

**WANTED.**—First-class traveling salesman with established trade in western or central States to represent both jobbers' and manufacturers' line. The O. E. Bell Co., Cincinnati, Ohio.

## Business Opportunities.

**ONLY JEWELRY STORE** in growing manufacturing town in New York; weekly pay roll averages \$10,000; poor health reason for selling. Address A. B., care JEWELERS' CIRCULAR.

\$1,200 will buy my 6,800 lb. steel-lined safe, plate glass store fixtures and balance of my clocks and silverware; will sell watches and jewelry if wanted; best opening in Oklahoma for a live jeweler. Chas. E. Rose, El Reno, Oklahoma.

**FOR SALE** in Philadelphia, a desirable business in a fine locality; clean stock about \$8,000, which can be reduced if desired; walnut fixtures, fine regulator, safes, etc.; good run of work; established 12 years. Address O. E., care JEWELERS' CIRCULAR.

\$650.00 **SPOT CASH** buys fixtures, material and optical goods of leading jewelry and optical store; established 15 years; western New York; bench work \$1,500 per year; only optician; will sell any other part of stock if desired. Address J. O., care JEWELERS' CIRCULAR.

## A. WITTAUER,

SUCCESSOR TO  
J. EUGENE ROBERT & CO.,  
IMPORTER AND MANUFACTURER OF  
PLAIN AND COMPLICATED

WATCHES AND  
WATCH MOVEMENTS,  
19 Maiden Lane, New York.

## To Let.

**TO LET**—A good office on the third floor in the Diamond Exchange Building, 14 Maiden Lane, N. Y.; now occupied by the Fletcher Watch and Jewelry Co. This office will be rented very low to May 1, 1897. Apply to Janitor, or Smith & North, 14 Maiden Lane, N. Y.

## For Sale.

**FOR SALE.**—A Marvin fire-proof safe; outside width 54 inches, height 65 inches, depth 28 inches. R. A. Loveland, 177 Broadway, N. Y.

## FOR RENT.

Large Office,  
5th Floor - - **Corbin Building.**

Will let very low for  
Three Years.

APPLY, - - - -

**JOSEPH FAHYS & CO.,**  
NO. 54 MAIDEN LANE, N. Y.

## TO RENT.

Back office, first floor, 20x40, new store building, 9 East 16th St., New York. All modern conveniences; fine light, suitable for silversmith or jewelers; rent very moderate.

**EDWARD TODD & CO.**

W  
A  
T  
C  
H

GOLD FILLED.



C  
A  
S  
E  
S

S  
P  
E  
C  
I  
A  
L

**SPECIAL**  
IN  
**THE JEWELERS'**  
**CIRCULAR**

Produce the  
results desired.

N  
O  
T  
I  
C  
E  
S

**BOOKS**

— FOR —

**JEWELERS.**

THE  
JEWELERS' CIRCULAR  
PUB. CO.  
189 BROADWAY, N. Y.

Send for  
New Catalogue  
of 200 Books

pertaining to the Jewelry, Watchmaking, Assaying, Engraving, Optical and Kindred lines, published or for sale by the Jewelers' Circular Publishing Co. The only complete Catalogue published for these trades.

Sent Free upon Application.

The Jewelers' Circular Pub. Co.,  
189 BROADWAY, N. Y.

THE STAR OF EMPIRE WESTWARD TAKES ITS WAY!

# WESTERN SUPPLEMENT of THE JEWELERS' CIRCULAR

VOL. XXXII.

CHICAGO, WEDNESDAY, JUNE 10, 1896.

No. 19.

## Chicago Notes.

All communications in reference to the Chicago department of *The Jewelers' Circular*, addressed to S. Parlin, 1527 Wrightwood Ave., Chicago, will receive immediate attention.

Simons, Bro. & Co. are stocktaking, after two months of very busy work.

J. A. Limbach, representing Foster & Bailey, left Sunday week for a month of business west.

G. A. Carpenter, Boston, Mass., spent the week at the Crescent Watch Case Co.'s Chicago office.

G. F. Schmidt has discontinued his store at 865 Clybourn Ave. and located at 85 Dearborn St.

A. W. Engel & Co. have moved from Dearborn St. to the southwest cor. State and Chestnut Sts., North side.

D. A. Wilkins, Ostby & Barton Co., came in Wednesday from the east, with a nice line that has produced good business.

John H. Mather, manager for George H. Fuller & Son, has been ill for two weeks with typhoid, but is now improving.

Joseph Ruff, formerly of the Grand Pacific Hotel, opposite Board of Trade, has moved to Monroe St., just east of Dearborn St.

Louis Manheimer returned the middle of the week from West Baden Springs, Ind., where he has been drinking the waters.

Acceptances are received almost daily by O. W. Wallis & Co., and there now seems to be no doubt that the settlement will shortly be completed.

Jobbers generally are more advanced in their preparation toward Fall catalogues than usual and are pushing manufacturers for advertising cuts.

Travelers from the east are numerous, mostly here on "catalogue" business, and the "carriers" usually seen about the hotels are all employed. The travelers are doing fairly well this trip, and are in good humor. Watch and case manufacturers will enter the field as soon as the jewelry men are out of the way.

Manson & Baker, who failed some 10 or 12 years ago, at Rockford, Ill., are in town endeavoring to effect a settlement, and are offering 10 cents cash. Judgments entered at the time of the failure amounted to between \$5,000 and \$6,000, divided among 15 to 20 creditors.

Feb. 29, M. A. Bredt filed a *praecipe* in a plea of trespass on the case of promises against J. F. Shambaugh, jeweler, 3902 Cottage Grove Ave., for \$500 damages, returnable to the March term of court. Writ was served March 1, 1896. April 21 defendant was given till May 1

to plead. May 11 Shambaugh denied plaintiff's charge and claimed good defense. On the same day, however, the motion for plea was stricken from the files, and in default of plea judgment entered for \$428.38 and costs. On this judgment, and despite the fact that in February previous

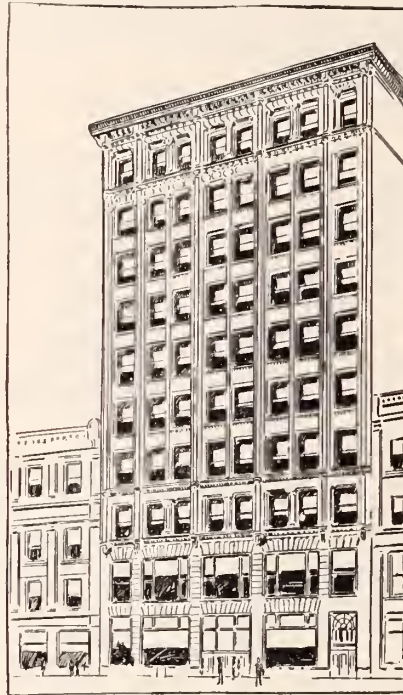

THE SILVERSMITHS' BUILDING, CHICAGO.  
NOW ERECTING.

Shambaugh had given a bill of sale to his mother, Bredt had execution issued, and put a sheriff in charge of Shambaugh's store, whereupon Shambaugh settled the Bredt judgment. The judgment was secured on two promissory notes from Shambaugh to Bredt—one dated Dec. 31, 1895, for \$323.14, carrying six per cent. for sixty days; and the other of date Feb. 1, 1896, same interest, and sixty days, for \$100. These notes were indorsed M. A. Bredt, John M. Bredt & Co. "I would have replevied the stock," said Mr. Shambaugh, "but as I intended to pay the account anyway, I paid it at the time rather than have my business closed up for a week or more." Mr. Shambaugh manages the store for his mother, and says his outstanding liabilities are local, and will aggregate but a small amount, the largest single account being for about \$113. The bill of sale to Mrs. Shambaugh was in consideration of money advanced the son, when he opened up at his present location.

## Louisville.

George H. Kettmann is in St. Louis on a business trip.

S. Lieberman has removed from 4th St. to Market St. between Floyd and Preston Sts.

R. L. Marshall, retail jeweler, Elizabethtown, Ky., called on the wholesale firms here last week.

T. J. Pottinger, of Rodgers & Pottinger Jewelry Co., has returned from his second trip east in the last few weeks.

W. Kendrick's Sons are presenting to their customers a novel and instructive little book showing the evolution of the timepiece.

The early closing movement among the 4th St. jewelers was again introduced last week, but Mr. Wolf still strenuously objects, and it will not be carried out before July 1st.

## Pittsburgh.

Frank H. Hartman spent a part of last week in Canton, O.

M. J. Huhn & Co. have removed from Fourth Ave. to 254 Fifth Ave.

George West, of West, White & Hartman, is in "off the road" until Aug. 1.

J. Shimp and W. H. Maire, of the Dueber Watch Case Mfg. Co., were here last week.

Edward Purkey was convicted of stealing \$200 worth of jewelry from B. E. Arons, and received a six months' sentence to the workhouse.

Grafner Bros. are improving their store by putting in new show cases and an elevator, and by painting.

A number of jewelers visited the city last week. Among them were noted: H. H. Weylan, Kittanning, Pa.; A. A. Poole, Washington, Pa.; Geo. V. Brady, Washington, Pa.; A. C. Kuntz, Natrona, Pa.; H. S. Johnston, Apollo, Pa.; J. C. Rhodes, Homestead, Pa.; B. Neville, Dawson, Pa.; N. C. Cochran, Fairmount, W. Va.; John Linnenbrink, Rochester, Pa.; William Hunt, Uniontown, Pa.; Mr. Kerr, Mars, Pa.

Twenty-eight diamonds, ranging in weight from one-half to two and a half karats, were found in Allegheny one week ago Friday by John Dunn, an Irish stonemason, employed by Contractor Huckenstein. Dunn was engaged in tearing away the old foundation of a house that occupied the corner of East and 1st Sts. for 30 years, and found the unset sparklers wrapped in a piece of chamois skin several feet beneath the surface. Their value is estimated at \$2,500. No one claims the stones.

**Pacific Coast Notes.**

J. D. Bennett has opened in Newcastle, Cal., as a repairer.

Mr. Naher, Sacramento, Cal., has removed to 1921 Mariposa St.

A. P. Hall has succeeded to the business of Jeweler Frutig, Gilroy, Cal.

L. Hunziker has opened a new jewelry and optical store in Moscow, Idaho.

R. C. Richmond, Arcata, has added a large stock of jewelry to his establishment.

Harry Rawson has purchased the jewelry stock formerly owned by W. P. Kooper, Moscow, Idaho, and will continue the business.

A. F. Lowenthal, who travels for A. Eisenberg, San Francisco, has just returned to San Francisco, after traveling through the north-west four weeks.

Bishop Page's store, Payson, Utah, was burglarized recently, jewelry and showcase goods to the value of \$150 being stolen.

W. Friedlander, Portland, Ore., has given the Commercial National Bank, of that city, a realty mortgage for \$7,447, and a chattel mortgage for \$7,697, and has conveyed realty for \$650. The principal creditors are San Francisco firms.

**Kansas City.**

F. A. Schaak, Kansas City, Kan., has gone to New York for a few weeks' visit.

Victor H. Kohn, with H. Oppenheimer, returned last week from an extended eastern trip to New York, Boston and Chicago.

F. W. Meyer has returned from St. Louis, where he spent some time last week. Mr. Meyer just escaped the cyclone, although some members of his family were slightly injured.

John Truby, senior member of the Truby Jewelry Co., Independence, Kan., died suddenly of heart disease last Monday. Mr. Truby was one of the early settlers of the town, being one of the first jewelers in Kansas. He was very popular among the travelers and with the trade in general.

Among the out-of-town buyers here last week were: B. R. Smithers, Cameron, Mo.; Niel Hudson, Winfield, Kan.; C. L. Taylor, Sedalia, Mo.; J. A. Wills, with J. Eller & Co., Richmond, Mo.; B. Hoffman, Leavenworth, Kan.; A. Melliush, Ottawa, Kan.; H. E. Conklin, Chanute, Kan.; Geo. Hudson, Winfield, Kan.; Geo. E. McCoy, Polo, Mo.; Geo. Hayward, Independence, Mo.

The jewelers of this city have united to fight the excessive telephone rates

and have agreed to have all telephones removed or pay the rates established by the city instead of the company's excess rate. The following jewelers have signed: Woodstock, Hoefler & Co.; J. A. Norton & Son; Edwards & Sloane Jewelry Co.; Hugh Oppenheimer; W. E. Cannon & Co.; H. E. Wuerth, and Meyer Jewelry Co.

**Detroit.**

Dr. Carpenter, oculist and optician, has opened headquarters over the store at 146 Woodward Ave.

C. L. Comfort, jeweler, Syracuse, N. Y., and Miss Ena White, Monroe, Mich., were married last week.

Horace W. Steere, of Arnold & Steere, was in the city last week looking after his store here, and visiting the trade.

R. E. Brackett, Lansing, Mich., last week finished 112 gold and silver medals which will be given as prizes in the intercollegiate athletic meet in Albion, Mich.

S. K. Selkirk, father of jeweler A. T. Selkirk, Charlotte, Mich., died last week from a stroke of apoplexy. He was 76 years of age and formerly conducted a large jewelry establishment in Kalamazoo. Mr. Selkirk was a prominent Knights Templar.

Hugh Connolly, Opera House jeweler, has devised a walking stick with a representation of the head of William McKinley on the end of it. He has asked Mayor Pingree to allow the use of his portrait for the same purpose.

R. S. Patterson & Co., jewelers, book and musical dealers, Port Huron, Mich., have dissolved partnership. Three separate firms will take the place of the old concern. R. S. & J. D. Patterson will constitute the firm of jewelers. They will occupy their old location.

Minnie Howard last week presented a check to Siebel Brothers, Saginaw, Mich., for \$18, signed by Jesse Cummings. She said he gave it to her to buy a diamond engagement ring. She got the ring but the check was worthless. Minnie gave up the ring and broke off the engagement, and the firm refuse to prosecute Cummings.

Harry Lockwood was last week placed on trial here charged with stealing a watch from jeweler Albert Schaub, 105 Gratio Ave. It is alleged that Ollie Lemming held the attention of Schaub while Lockwood took the watch which had been left at the store for repairs. The jury disagreed, and he will be tried again.

**Indianapolis.**

Wm. Hirsch, Union City, Ind., recently suffered a \$400 loss from a fire in his jewelry store.

E. C. Miller and family left Indianapolis on the 6th and sailed for an extended trip abroad on June 9.

C. M. Hunnicutt, Rockville, J. W. Hudson, Fortville, A. Meissen, Cicero, Thos. F. Cahill, Spencer, visited the Capital city last week to buy goods.

General trade is very dull, but the sale of remembrances for the June graduates and presents for the June weddings has been very good. The Indianapolis bride now considers a loving cup necessary if she is to begin house-keeping in the latest and most complete fashion. The cup to be used at the wedding feast and at all family gatherings, as well as on special occasions.

AVOCA, IOWA.

Please find enclosed postal note for two dollars (2.00) in full of our one (1) year subscription to THE CIRCULAR. I have taken THE CIRCULAR through our local news agent for the last three or four years, and could not do business without it. Wishing you success, I am,

M. BARNES.

**THE PERFECTION**

**SHOW CASE**

FOR FINE JEWELRY TRADE.

WE CHALLENGE THE WORLD TO PRODUCE ITS EQUAL.

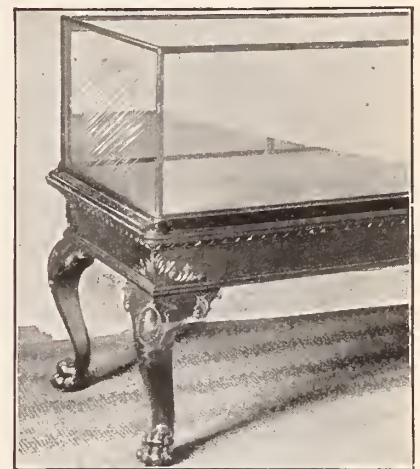

IF YOU ARE INTERESTED IN SHOW CASES AND JEWELRY FURNITURE, WRITE US FOR FULL INFORMATION.

**A. H. REVELL & CO.,**

431 to 437 Fifth Avenue, Chicago.

**COLONIAL**

IN STERLING SILVER TABLE WARE.



SMALL SUGAR TONGS.

JEWELERS ONLY.

**TOWLE**  
MANUFACTURING COMPANY,  
NEWBURYPORT, MASS.

Chicago, 149-153 State St.

**ONE**Agent wanted in every town  
to sell the**STRICTLY HIGH GRADE****\$100.00 BICYCLES**Write for Catalogue and Agents'  
Terms.Send 10 Cents for Elgin King  
Scarf Pin.

Address Department B,

**ELGIN CYCLE CO.,**  
ELGIN, ILL.VISITORS TO THE  
**National Republican Convention**  
ARE INVITED TO MAKE THE STORE OF**THE A. S. ALOE CO.,**

...DEALERS IN...

**OPTICAL GOODS,**  
THEIR HEADQUARTERS.512 Locust Street,  
ST LOUIS.**JEWELERS...**Visiting **ST. LOUIS** During the  
**National . Republican . Convention**Are Cordially Invited to Call  
On and Inspect the Stock of**ARLINGTON R. BROOKS,**

— Wholesale Dealer In—

**WATCHES,****JEWELRY**  
AND **OPTICAL GOODS,**  
**GLOBE-DEMOCRAT BUILDING,****S. W. Cor. 6th and Pine Sts.**EST.  
1870.**DR. PETER HENRY,**

SPECIALIST IN

**Watch Case Diseases**Key Winders  
changed to  
Stem WindersHunting Case  
changed to O.sEnglish Case  
changed to fit  
American  
movements

Can be cured at

**53**  
**LONGWORTH ST.,**  
Cincinnati, Ohio.**PARSONS & SCHOOL**

— FOR —

**WATCHMAKERS,**

PEORIA, ILL.

Send for Circular and Terms,

**PARSONS & CO.****Cincinnati.**

L. Gutman has returned from a fishing expedition on the Lakes.

The Cincinnati factories still report a large amount of work coming in.

The O. E. Bell Co. dropped some of their travelers, but are now negotiating with two others. They still want a few more.

Fox Bros. &amp; Co. received another shipment of diamonds last week, and will be ready to outfit all their travelers with a star line on their next trip.

Clemens Oskamp has just completed a renovation of his splendid premises. The entire salesroom is laid in tiling and the ceiling is handsomely frescoed.

J. Frohman, of Frohman, Wise &amp; Newman, leaves for a vacation this week. It is said that he has bought a farm and will try his hand this Summer in his new pursuit.

The eastern men in Cincinnati last week became discouraged and stayed only one day, where they used to stay three or four days. They get in in the morning and leave on the evening train.

Albert Bros. are putting in a large line of silver novelties, toilet sets, etc., and are placing in extra cases for their display. They got a corner on a certain line and expect to make these articles "hum."

There have been a number of visitors in town interviewing the trade, among them; Victor Bogart, Lexington, Ky.; John Bollinger, Maysville, Ky.; Dr. Le Fevre, Hillsboro; D. W. Barnes, Marion.

Peter Henry says it is rather fortunate for him that people continue to smash their watches. Some of the watches that come in for repair look as if something worse than a cyclone struck them.

Jos. Mehmert has just returned from an extended trip through the south and says that although the business there amounts to almost nothing now, there are very promising prospects for a good Fall trade, as the crops are excellent.

The Cincinnati opticians held another meeting last week and the committee made their report on their trip to Columbus. The organization bids fair to become a strong one as all the trade are united and perfect harmony prevails. President Prince stands at the head of the profession in Cincinnati and has a strong following from the numerous houses who are in the organization.

The Cincinnati Wholesale Jewelers' Association held their regular monthly meeting Tuesday last, President Gutman presiding. There was a very large attendance and much interest was manifested in the subject of the credit system, which was discussed at length. A special meeting is called for next Saturday to take some steps toward the formation of a

system that will meet all the wants of the members.

The State convention of the Ohio Retail Jewelers' Association convene at Piqua on the 9th, 10th, 11th, of June. The principal business of the meeting will be the election of officers and the appointment of delegates to the National Convention which occurs on the 16th, 17th and 18th of July, at Atlantic City. A large delegation of Cincinnati jewelers will go over to the National meeting, but it is thought that few will go up to the State convention. Ed. Lohmeyer, Louis Hummel, H. H. Mithoefer and probably a few others will go to Piqua. They will also go to the National meeting.

**St. Louis.**

A. S. Wormwood, of the Illinois Watch Co., is in the city.

Henry Estinghausen, of the Attleboro Jewelry Co., is away to southern Illinois points.

The regular monthly meeting of the board of directors of the Missouri Retail Jewelers Association will take place June 10th.

Gerhard Eckhardt, 1242 S. Broadway, is rapidly disposing of his stock by the continuous auction plan. He will shortly remove to the old stand of J. A. Droz, 6th near Olive Sts.

The following traveling men were in town last week: A. J. Sherrard, Enos Richardson &amp; Co.; Mr. Weinberg, Low, Weinberg &amp; Co.; W. P. Stowe, W. H. Wilmarth &amp; Co.; Mr. Vasselet, E. B. Thornton &amp; Co.

The medals, cups and other prizes to be contested for at the great Sharpshooters' Festival in this city on June 13th, 14th and 15th, are on exhibition in the windows of the Mermod &amp; Jaccard Jewelry Co. They represent an outlay of \$10,000.

Mermod &amp; Jaccard Jewelry Co. received on June 5 their World's Fair award. Among other reasons for them obtaining it the award says: "For the high excellence, uniform grade, and fine quality of the diamonds and precious stones, and for the artistic and exquisite beauty and originality of the mountings. The graceful outlines and original conceptions and beauty of their Louis Quinze designs of solid silverware as shown in their breakfast, tea and dinner services, as well as on their Pompadour, Lorraine and St. Louis patterns of silver spoons and forks."

**Columbus, O**

H. J. Heimberger, the new South side jeweler, has invented an article which will be presented to the public later, when more fully perfected.

F. F. Bonnet is the only jeweler who carries stationery. The past year he has added largely to his stock and now has a handsome and complete line of goods.

Our jewelers are seeking revenge on the bicycle dealers by adding bicycles to their stock. The jewelers say that heretofore it was customary to give a son or daughter a gold watch at the time of graduation, but now a wheel is the popular gift.

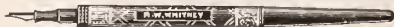
**NEVER BLOTS ADJUSTABLE ALWAYS READY.****The Whitney Adjustable Fountain Pen.**  
The only pen made using adjustable feed to regulate the flow of ink.**EVERY PEN GUARANTEED**and money refunded if not satisfactory. Retailers from \$1.75 to \$5.00. Write for catalogue and discounts to dealers.  
**R. W. WHITNEY, 236 SUPERIOR ST., CLEVELAND, O.**



## News Gleanings.

Chas. P. Bloom, Mercur, Utah, has left the city.

W. H. Hoyt has opened a new jewelry store in Ordway, Col.

A. E. Tinker has sold out his jewelry store in Redlands, Cal.

H. L. Rogers has sold out his jewelry business in Mercur, Utah.

Helm's jewelry store, Steubenville, O., is again open for business.

A. E. Winter has opened a new jewelry store in Columbus, Kan.

H. E. Hindelang, Ogden, Utah, has given a chattel mortgage for \$550.

B. Talazac is offering his jewelry store in Los Angeles, Cal., for sale.

The trust deed given by E. & E. Rose, Joplin, Mo., has been released.

Cox & Peden have gone into the jewelry business in Mt. Vernon, Mo.

The jewelry store of C. P. Christensen, Mercur, Utah, has been closed.

C. E. Van Voorhees, Monett, Mo., is selling out his stock of jewelry at auction.

The jewelers of Erie, Pa., have decided to close their stores four nights a week.

Rowe & Beeler have purchased the jewelry store of J. C. Wilcox, Pleasant Hill, Mo.

George Horspool, Galesburg, Ill., is selling out his stock at auction. T. A. Dawson, of Chicago, is the auctioneer.

In a fire in Afton, Ia., the store of Harry Harman, dealer in jewelry and queensware, was burned out; loss \$5,000.

W. E. Disher has succeeded to the book, cigar and jewelry business of the St. Edwards News Co., St. Edwards, Neb.

John A. Musch, Mellette, S. D., has given a bill of sale on his jewelry and drug business for a consideration of \$1.00.

M. A. Keepert, 132 9th St., Reading, Pa., will shortly remodel and enlarge his store room. A workshop will be added to the rear, in which will be placed several machines for use in the manufacture of rings and badges.

Burglars entered the jewelry store of Michael Donawicz, Mt. Carmel, Pa., on the night of May 31 and took everything in sight. The articles stolen include 50 silver watches that were being repaired and belonged to different parties about town, 12 new gold watches, five revolvers and three dozen plated watch chains. The loss is estimated at over \$500.

Burglars entered the jewelry store of Arthur M. Bean, 435 7th St. S. W., Washington, D. C., last Friday night, and stole a number of gold watch cases and a gold chain. An entrance was effected by breaking a plate glass window in the front of the store. Mr. Bean discovered next morning when he went to open his store that some one had visited it during the night.

A few days ago the jewelry stock of the late Geo. Barrett, Boone, Ia., was sold at auction to satisfy a mortgage amounting to \$3,500, held by the wife of the deceased. Mr. Mellish, a son of Mrs. Barrett, was the only bidder, and secured the stock for \$2,800. Attorney Crooks appeared and announced that his firm

represented clients who had claims against the stock, and would contest the sale because it had not been properly advertised, and the mortgage given by Mr. Barrett to his wife was without consideration.

## New Jewelry Businesses.

H. W. Button, Victoria, Tex.

Bardo & Calvert, New Brighton, S. I., N. Y.  
D. S. Porter, Bennett block, Avon Park, Fla.

George C. Lang, formerly of the jewelry firm of Lang & Campbell, Morrisville, Vt., has opened a jewelry store in Barre, Vt.

The Ernst Jewelry Co., at Pueblo, Col., have incorporated with a capital stock of \$3,000, in single shares of \$10, for the manufacture, sale and repairing of jewelry. The promoters are: Lawrence L. Ernst, R. M. Ernst and Frederick W. Text, of Pueblo.

A petition for a charter for the Atlanta Watch Co., Atlanta, Ga., was filed in the clerk's office, May 30th, by L. D. Quintt Teakle, as attorney for E. R. Black, S. R. Peck and others. The petition asks that the company be chartered for the space of 20 years, with a capital stock of \$3,000, of which 10 per cent. shall be paid in before business is started. The business of buying, selling and making watches and other jewelry shall be conducted, and the headquarters of the company shall be at Atlanta.

## Some Views Regarding "The Circular."

BELTON, TEXAS.

Vol. XXXI., No. 19, of your CIRCULAR has never reached us, and being desirous of having unbroken volumes, can you not send us the above number? W. S. HUNTER & Co.

LOS ANGELES, Cal., May 14, '96.

For over 20 years our senior partner, Mr. James A. Montgomery, has been a subscriber to your worthy paper. The name has not been changed to our firm name. Each week the numbers are duly read in our office and appreciated for their valuable information, their practical application, and the bright, newsy character of the items you record.

MONTGOMERY BROS.

## Connecticut.

The E. Ingraham Co., Bristol, now running five days a week, after July 1 will run 6 days a week.

The property and stock of the insolvent estate of jeweler Richard Noack, Norwalk, were sold at public auction, June 6.

M. P. Leghorn's jewelry store, New Britain, was damaged to the extent of \$200 by fire May 28th. The fire broke out in an adjoining store.

Mrs. Burgess, wife of President Burgess, of the Burgess Cut Glass Co., Middletown, has been very ill from nervous prostration since she was shot recently.

Geo. B. Steel, Waterbury, has been appointed superintendent of the rolling department by the Bristol Brass and Clock Co., succeeding Ira B. Newcomb, deceased.

Frederick Linsley Roessler, of Roessler & Son, New Haven, was united in marriage June 3d, at the parsonage of St. Mary's church, to Miss Helen Agnes Mulligan, of New Haven.

P. H. Stevens & Co.'s show window, Bristol, was on Memorial Day most artistically and attractively arranged with red, white and blue, which effectively set off the dainty ware and jewelry displayed.

Fire Commissioner Kohn, of Henry Kohn & Sons, Hartford, had the honor of receiving the order for an elegant diamond stud for a presentation gift, from 50 special agents and representatives of the fire insurance companies doing business in that section.

The following Hartford jewelers signed an agreement to close their stores at 5 o'clock P. M. (Saturdays excepted), during the Summer months, beginning June 1st: Henry Kohn & Sons, C. H. Case & Co., Hansel, Sloan & Co., Mayer, Grace & Mayer, Ernst Schall Co.

The city of New Haven has just paid S. Goodman & Co., jewelers, \$10 for damage done one of their show windows by the falling of a projecting sign from an upper story, which was blown down in a gale of wind one night. The city authorities have since that accident, and owing to other causes, passed a stringent ordinance regarding projecting signs.

# NICKEL "Sun" TIMER

WITH 30 MINUTE REGISTER.

\$4.25, less 6° for Cash.



BYRON L. STRASBURGER & CO.,

Importers of Watches and Makers of Diamond Jewelry,

11 MAIDEN LANE, NEW YORK.

COMBINATION  
PURSE AND  
GLOVE  
HOOK.

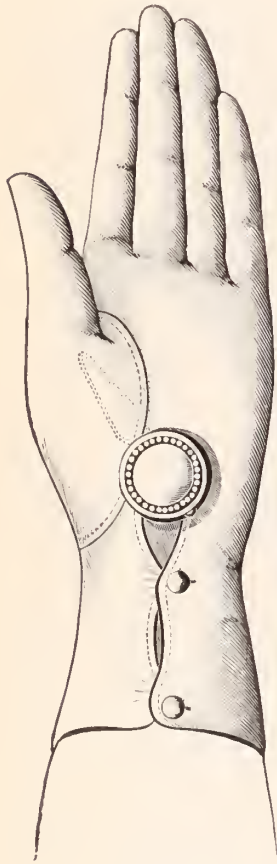
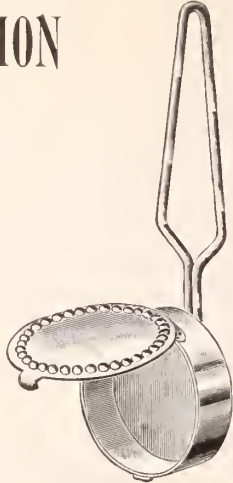

This absolutely new article is bound to have a large sale. It is extremely convenient, serves as an easily accessible carrier for small change such as is required for car-fare—is securely held in the palm of the hand and saves its wearer from the insanitary practice of holding coin between the lips.

A SPLENDID NOVELTY  
MADE IN STERLING SILVER.



We are makers  
of Sterling  
Silverware  
Exclusively.  
All goods  
925-1000 fine.

F. M. WHITING CO.,  
North Attleboro,  
Mass.

Letters to The Editor.

THE DUEBER CO.'S INTERPRETATION OF THE  
COLBY PATENT SUIT DECISION.  
CANTON, O., June 5th, 1896.

Editor of THE JEWELERS' CIRCULAR,

Your enterprise in publishing the full text and illustrations of the recent decision in our favor, in the United States Circuit Court of Appeals, at Cincinnati, O., of the Pendant Set Watch Case Suit, is highly commended, and is read by the trade with great interest. The only error in same is in the last sentence, in which the word "appellants" should read "appellees" as the costs must be paid by the defeated parties. The Clerk of the Court informed us of this error of the printer, as stated above.

The statement made by the other side, that "the effect of this decision is to permit the manufacture of Pendant Setting Watch Cases, without license," is not correct, as will be seen later. We would also inform the trade that, in all probability, the decision of the courts, in regard to pendant setting watches, will doubtless be reversed on a re-hearing of the points involved, and any watch manufacturer who has any desire to make a pendant setting watch, can do so, providing sale is found for them. We also wish to state that, while it is true that the Colby Patent litigation had nothing to do with the settlement of the so-called trust suits brought by this company against the members thereof, this very pendant setting device was one of the, at the time, strong points which held that organization together.

The statement that we failed in the trial of suit is misleading. The jury disagreed, as the trade well knows, and further trial might have shown different results had not a mutual agreement to drop the litigation been presented to us by the other side, and entered into by this company.

Yours respectfully,  
THE DUEBER WATCH CASE MFG. CO.

ADJUSTABLE FEED PENS AND OTHER MATTERS.

BROOKLYN, N. Y. June 3, 1896.

Editor of THE JEWELERS' CIRCULAR:

Please add the word "feed" in the ad. of Mabie, Todd & Bard, in your paper as per copy inclosed to make the line read "3 sizes adjustable feed Swans."

This is necessary by reason of the ad. of one Whitney in yours of May 26, '96, which is misleading as the inclosed circular explains that 1892 was the year in which such were made. The application for the patent was before the Patent Office Examiner in 1886, was delayed by an interference until about 1889, and made in 1892. The matter is now before the court in the case of W. W. Stewart against the American News Company, for selling the Wirt pen and also one made under this later patent; there is not a fountain pen of prominence on the market but what has features of Stewart's disclosures.

It is the same as regards elastic cushions to prevent bone-shaking; in the '70s the writer disclosed and patented a structure, an elastic

cushion to assist the aged or infirm to retain the elasticity of youth in locomotion. One of these structures shows an elastic tube attached to the instep of a boot, as the proper place for resiliency; compressed air cushions are also shown. It is plain that after such a disclosure, the attachment of elastic cushions to other parts of the body or a vehicle is an adaptation merely. *Munsey's Magazine* for May, 1896, says in 1889 an Irish boy named Dunlop in Belfast complained of the bone-shaking qualities of his wheel, and an indulgent father studied out and invented a hollow rubber tube filled with compressed air." Yet after all this we read a warning to dealers in bicycles that the patents of Nov. 29, '92, and May 23, '93, for improvements in pneumatic tires, "cover the manufacture, sale and use of all single tube or hose pipe tires in the market." How can this be? Such a broad interpretation would enervate jewelers and others who may invent non-puncturing devices; for them the information about elastic cushions to prevent jarring of the human frame is given.

W. W. STEWART.

Report of Watch Inspection on the  
Illinois Central Railroad.

CHICAGO, Ill., June 6.—The report of the second quarterly inspection for 1896 of watches on the Illinois Central Railroad, has just been issued by J. W. Forsinger, general inspector, third floor, Columbus building, as follows:

Examined.....	4,528
Compared with standard time weekly.....	2,699
Average days' run for rated watches.....	25
Average daily variation in seconds for rated watches.....	.5
Rejected as unsafe.....	25

The following for the second quarter of 1896, shows the condition of watches on the Eastern Illinois:

Examined.....	455
Compared with standard time weekly.....	308
Average days' run for rated watches.....	19
Average daily variation in seconds for rated watches.....	.7
Rejected as unsafe.....	1

Chicago Great Western report:

Examined.....	631
Compared weekly.....	331
Days' run.....	23
Variation.....	.7

The report speaks well of the high grade required for this difficult service, and the thoroughness with which the inspection is conducted.

A Few Words of Compliment.

LOCKPORT, N. Y., June 4, 1896.

Enclosed find \$2 to renew our subscription to JEWELERS' CIRCULAR. We appreciate the good work you are doing in the interest of the legitimate jewelry trade.

BROWN, HIXSON & Co.

DEL NORTE, COL., May 9, 1896.

It is utterly impossible to get along without your valuable paper, "THE JEWELERS' CIRCULAR," therefore we enclose P. O. order for \$2, amount of subscription due for 1896.

CHARLES TUCKER & SON.

**Queries by Circular Readers.**

**NOTE.**—Questions under this department will be answered as promptly as possible. Some queries require careful investigation before a satisfactory answer can be given; hence such answers are often seemingly delayed. The Circular desires every jeweler to take advantage of this department.

New York, June 2, 1896.

Editor of THE JEWELERS' CIRCULAR:—

Some time since I saw a paragraph stating that after Lincoln's assassination the National Jewelers' Association passed a resolution to the effect that all dummy clocks used for sign or advertising purposes should be painted to mark the hour when the martyred President died. This seemed to me a very beautiful idea, and I gave the alleged fact to the readers of the *Advocate*, of whose editorial staff (as Lincoln would say), "I am one of which." Thereafter for a time I revelled in admiration of the sentiment of the Jewelers' Association, but was rudely awakened by discovering that Abraham Lincoln died at 7.23 A. M., and not at 8.17, the hour usually represented on the dummy clocks.

Can you tell me whether there is such an organization as the National Jewelers' Association? If so, do you know whether any such action relative to Lincoln's death was taken? If you do not know, can you tell me who would be the best person to address to get information?

"Floating lies" are disagreeable to meet at any time; it is humiliating to find one's self in the attitude of furnishing favoring breezes for their further travels on the journalistic seas. I would like to sink this one, if possible, or prove it to be legitimate flotsam.

JOSEPHINE L. BALDWIN, *Christian Advocate*.

**ANSWER:**—At the time of the assassination of President Lincoln there was no National Jewelers' Association in this country. The National Retail Jewelers' Association, as it exists to-day, W. F. Kemper, secretary, 2326 Franklin Ave., St. Louis, Mo., is of comparatively recent birth, and has had nothing to do with the subject referred to in your letter. The story why all the dummy clocks point to 18 minutes past 8 o'clock first appeared in an article in the *New York Sun*, Nov. 18, 1888, of which the following is a reprint:

"A reader of the *Sun*, who was also, as all *Sun* readers are, an observing man, recently sent a letter to this office asking why it was that every clock and watch maker who slung an imitation clock or watch outside his shop as a sign had the hands painted on the face at exactly 18 minutes after 8 o'clock. This was a poser to every clock seller a reporter asked. The signs came that way to them, they said. The majority of them had never noticed the curious coincidence. If asked where they got their signs painted the reply was that they left the order with their wholesale dealer and the sign came along. That was all they knew about it.

"Inquiries among the wholesalers in Murray street and Maiden Lane developed the

curious fact that there is no competition in the trade of painting clock signs. A man named Groot [Grou] has a practical monopoly of the Chicago market and the territory for hundreds of miles around. In Cincinnati W. H. Smith does the business without competition, and in this city, and for as many miles around as New York commands the clock trade, W. L. Washburn enjoys a laborious but enviable monopoly.

"This state of affairs is brought about by the wholesale clock and watch dealers themselves, who got used to patronizing these three dealers many years ago, and never got enough out of the habit of it to give any other painter the ghost of a show to succeed with an opposition shop.

"But Father Washburn, said one wholesale dealer, is father of them all, and of emblematic signs as well. He was the first painter to make a sign emblematic of any business, and he started in way back in '53. Why, the big concerns that make metal signs don't bother him at all. He gave his ideas to the whole world to copy, and the world got rich. The friends he made back in the '50s have stuck to him ever since, and one branch of the business has stuck so close that no competitor in other branches of sign work ever thinks of getting a clock or watch sign to make, and if by chance he did, he'd probably be so scared he'd probably send the customer to Father Washburn.

"Mr. Washburn was painting a clock on a big star when the reporter called. He was an old man with a happy face and a white beard. There were clock signs mapped out, half done, and finished, hanging all around, and every blessed one of them had the hands pointed at 18 minutes after 8 o'clock.

"The reason all the dummy clock hands point to that hour," said Mr. Washburn, "is because I paint them all and I always paint that hour. When I painted the first emblematic sign ever painted as a matter of business, back in '53, it was a clock. I don't know how I put in the hands. All I remember about it is that it was for P. T. Barnum's old concern on Cortlandt street, the Jerome Clock Company since gone up the spout. I painted the hands any way I chose, up, down, crosswise, or together, as my mood dictated, from that time up to April 14, 1865. That night the news was flashed into the city that Lincoln had been shot in Ford's Theatre. I was working on a sign for Jeweler Adams, who used to keep on Broadway, opposite

Stewart's, at that time. I was making a great clock to hang outside. Adams came running in while I was at work. He was a strong Lincoln man. He said:

"Point those hands at the hour Lincoln was shot, that the deed may never be forgotten."

"I painted the hands, therefore, at eighteen minutes after eight. The idea struck me forcibly, and when I came to look at the effect I found it was the most convenient arrangement since it displayed both the hands well, and left the top half of the clock free to paint in the name of the clock seller if desired. "So I threw all my stencils away and made new ones for that hour. I have never varied from the system since, and that's the reason all the clock signs point as they do. The Chicago and Cincinnati people I find, are doing the same thing. They don't know the story, but they were probably won to my plan by the capability of that particular arrangement for artistic display in painting."

This story was quoted and reprinted throughout the country. We have seen the son of Mr. Washburne, referred to in the article, and he indorses it. He says that about the time of the assassination his father made a clock dummy for a man named Barnum (not P. T.), and upon his request painted the hands pointing to 18 minutes past 8. This disposition of the hands had some reference to the assassination of the President. However, it will be seen that this disposition is a graceful one, as the hands divide the dial symmetrically, without interfering with the seconds hand, and without causing asymmetry, which would be the case if the hands were in a corner of the dial, as they would be if they pointed, for instance, to 9 o'clock. There is no doubt that this disposition of the hands was dictated in some degree by a sense of symmetry and beauty on the part of the painter.

BOSTON, MASS., June 2, 1896.

Editor of THE JEWELER CIRCULAR.

Can you tell us who makes the "Puritan" pattern in solid silver flatware?

KATTELE BROS.

**ANSWER:**—The "Puritan" pattern in silver flatware is made exclusively, we understand, for Daniel Low, Salem, Mass., by Frank W. Smith, Gardner, Mass. We presume Mr. Low sells the goods at both wholesale and retail.

PROVIDENCE, R. I. May 28, 1896.

Editor of THE JEWELERS' CIRCULAR:

I herewith like to ask you a favor by informing me who are the manufacturers of the Interlocking Glove Buttoner No. 1, patented Feb. 22, 1887, as I have some call for them.

JULIUS EICHENBEEG.

**ANSWER:**—The patentee of this glove buttoner, patent No. 358,118, was Thos. B. Hodge, Providence, R. I.

**DR. KNOWLES' PRIVATE COURSE IN OPTICS.**

Lectures with Diploma \$25.00

Those who desire to study with the Doctor will send in their application.

Students received at any time.

CORRESPONDENCE COURSE PERFECTED.

*The Key to the Study of Refraction.*

50c. per copy,

For Sale by

R. H. KNOWLES, M. D.,  
189 Broadway, NEW YORK.  
Care of JEWELERS' CIRCULAR,

**FINE CASES . . . . .**

for Jewelry, Silverware, etc.  
Hardwood Chests, Trays and sample cases. Business established in 1876.

Samuel C. Jackson's Son, 180 B'way, N. Y.

**JOHN T. PECK,  
WATCHMAKER**

—FOR THE TRADE.—

409 WASHINGTON ST.,

Room 15,

BOSTON, MASS.

**THIS TRADE MARK . . . .**



on cut glass is a guarantee of superior quality. Designs all new and original. Libby blanks used exclusively. Send for catalogue.

STANDARD CUT GLASS CO.,

545-547-549 W. 22d St., New York.

# The "Safety Case" FOR Riding Specs.

SOMETHING NEW . . . .

THIS INGENUOUSLY MADE CASE FILLS A LONG FELT WANT. IT IS STRONG, COMPACT, DURABLE AND CONVENIENT.

Ask Your Jobber for Them.

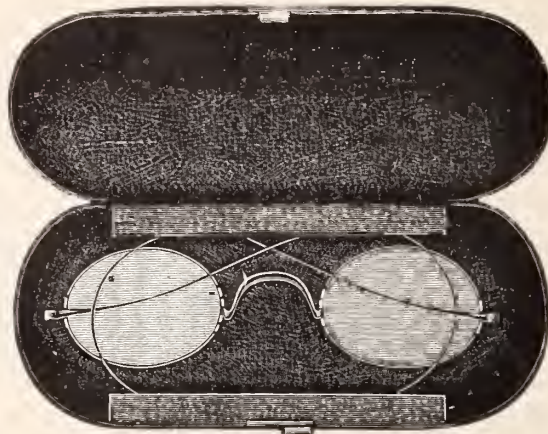

(PATENT APPLIED FOR.)

OUR REGULAR "SAFETY CASE," OF SIMILAR PATTERN, BUT SMALLER, IS THE BEST CASE EVER MADE FOR FRAMELESS, OFFSET EYEGLASSES.

For Sale by all Jobbers

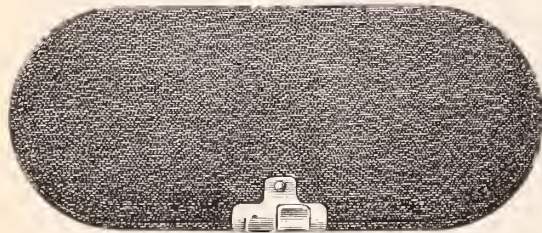

**SUSSFELD, LORSCH & CO.,**  
37 and 39 Maiden Lane, N. Y.

**Fox & Stendicke,**

Manufacturing Opticians,

61 Fulton St., New York.

Javal, Schiötz Ophthalmometers, Phorometers, Skiascopic Apparatus, etc., etc.

Send for Price List.

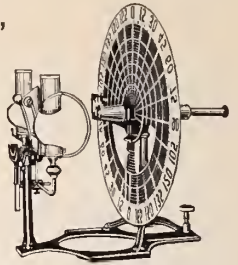

**O. NEWMAN,**  
Gold and Silver Electro-Plater.  
Etruscan Coloring a Specialty.  
WATCH CASE POLISHING.

75 Nassau St., Room 8 Rear Building, New York.

FOR RELIABLE OPTICAL WORK SEND TO

JOS. FRIEDLANDER & BRO.,  
OPTICAL LENS GRINDERS,  
9 MAIDEN LANE, - - NEW YORK.

SEND FOR DESCRIPTIVE CIRCULAR OF OUR FRAME AND LENS CABINET.

**THE SPENCER OPTICAL INSTITUTE**  
THE RECOGNIZED OPTICAL SCHOOL FOR BUSINESSMEN

OUR COURSE PRACTICAL COMPREHENSIVE NONCLASSICAL IN THEORETICAL AND APPLIED OPTICS

OUR STUDENTS ARE THE SUCCESSFUL OPTICIANS

SEND FOR APPLICATION BLANK & PROSPECTUS. CLASSES CONVEENE 1ST TUES. EACH MONTH  
SPENCER OPTICAL MANUFACTURING CO. 15 MAIDEN LANE . N. Y.

**WM. SMITH & CO.,** 5 and 7 MAIDEN LANE, NEW YORK.  
61 PECK ST., PROVIDENCE, R. I.

ESTABLISHED 1854.

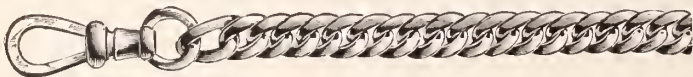

MANUFACTURERS OF

**Gold, Silver and Rolled Plate Chains and Jewelry.**

Novelties in Gold and Silver Bead Necklaces and Bracelets. Also a large line of Chain Trimmings and Silver Rings

## Optical Books.

Any book pertaining to the subject of ophthalmology can be obtained through the Jewelers' Circular Publishing Company. Send for new catalogue just issued. It is free.

**FERD. FUCHS & BROS.**  
**SILVERSMITHS.**  
MAKERS OF STERLING SILVERWARE,  
808-810 Greenwich St., - New York

**H. M. RICH & CO.,**  
**Jewelry - Auctioneers,**  
21 School Street,  
[BOSTON, MASS.]

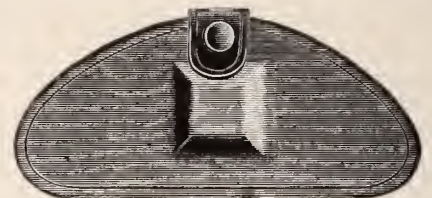

EXTRA THIN.



IN TWO SIZES.

**KOENEN'S NEW SHELL CASE**

FOR OFFSET EYEGLASSES.

THE LATEST AND BEST. THIN AND STRONG.

Manufactured and Patented by

**A. KOENEN & BRO.,** 81 Nassau St., N. Y.

— SOLD BY JOBBING TRADE.

# OPTICAL DEPARTMENT.

## Ocular Refraction.

AS RELATES TO THE CORRECTION OF VISUAL DEFECTS \*

BY R. H. KNOWLES, M. D.

**NOTE.**—The purpose of this series of articles is to give to the student without his having had any previous technical education, a clear and practical course of instruction in optics with its application to the fitting of glasses. The Correspondence Column is open to all readers of THE JEWELERS' CIRCULAR. All questions asked will be fully answered.

XXXIV.

(Commenced Feb. 27, 1895.)

### CHAPTER VII.

**R**EFLEX ASTHENOPIA is that variety of weak sight, pure and simple, due to a leak made upon the nervous system so that the muscles controlling the movement of the eyes suffer secondarily, in consequence of

Asthenopia we may mention several diseases, such as dyspepsia, together with disturbances which arise from the genito-urinary apparatus. Reflex Asthenopia, from whatever cause, may be so severe as to produce diplopia, either homonymous or crossed, which would have to attain as high as 16 degrees in order to cause the patient to see double.

In summarizing the three varieties of Asthenopia, it will be seen that Asthenopia may be considered as the primary or initial stage of squint, and that strabismus may be considered the more advanced or permanent stage. If the cause of either the primary or even the advanced stage be due to an error of refraction, the proper course to pursue is to correct that error, and then if there remains a trace of muscular insufficiency, Orthoptic exercises should be performed instead of pre-

ceptional cases, which only prove the rule.

If the strain placed upon the muscles is so great that convergent strabismus or the advanced stage is established in accommodative asthenopia, or divergent squint is the result of an insufficiency of the internal rectus in muscular asthenopia, the course to pursue is to correct the error first and then if this proceeding does not suffice, to experiment with prisms. Finally, in the above two varieties, if neither result in a restoration of balance of the muscles, place the patient in the hands of an ophthalmic surgeon for the purpose of performing tenotomy. He should operate with a view to restoring the eye in equilibrium, if both eyes can be made to have vision approximately as good as perfect, as well as for the cosmetic effect alone. In passing it might be well to state that if a solution of sulphate of atropine (four grains to the ounce of water, a drop in the eyes three times daily for three days), will straighten the eyes in a case of convergent strabismus; alone, the correction for the hyperopia will result in the eyes becoming restored to equilibrium.

In reflex asthenopia, if vision is good in both eyes, the proper course to pursue is to place the patient in the hands of his or her family physician for treatment of the disease, and if in the judgment of the refractionist, prisms should be worn, they may be prescribed.

In demonstrating the various kinds of heterophoria, several phorometers have been devised, and the art of employing this instrument for such a purpose is called phorometry.

(To be Continued.)



PHOROMETRY.

which we have precisely the same symptoms as in the other varieties, but in this particular kind there is no error of refraction, although with the error there may be also conjoined a reflex disturbance.

Among the causes which bring about Reflex

scribing prisms or decentered lenses, as it will readily be seen that by giving the gymnastic exercises for the muscles a tonic effect with ultimate restoration to equilibrium will be secured, while in giving temporary prismatic relief, the muscles are allowed to remain passive, and the rest thus secured cannot result in permanent good except in very ex-

### A SUGGESTION FOR SETTING JEWEL PINS.

ROCKPORT, MASS., May 16, 1896.

Editor of THE JEWELERS' CIRCULAR:

I notice an article on setting jewel pins in your last issue. Having never seen the plan I have used for 46 years set forth, by which the hair spring or roller plate scarcely ever needs be removed, I will give it to you for what it is worth. Take an old, small round file, draw the temper, put the small end in a wood handle, cut the square end off leaving a quarter inch of the square, filing it to wedge shape; now select a jewel pin to fit the fork, take on a pegwood point some liquid shellac and lubricate the jewel hole, place the jewel in the hole with a small bit of hard shellac placed at the back of the pin. Now heat the large end of the file and place it against the edge of the roller; do this two or three times until the shellac has boiled up hard. Then if the pin needs turning heat the file and touch the jewel only and it will come to position wanted.

If a substitute for a ruby pin has to be used a piece of a cambric needle broken to the size and length with the ends ground smooth is far better than a brass pin; in all cases I think a little oil in the fork gives a smoother impulse.

Yours, etc.,

M. MANNING.

# A JEWELER'S NECESSITY



— IS THE —

## “TRADE-MARKS OF THE JEWELRY AND KINDRED TRADES.”

Copyright, 1896, by The Jewelers' Circular Pub. Co., 189 Broadway, New York.

For seven months THE JEWELERS' CIRCULAR has had under way a work that will comprise the trade-marks of every branch of the Jewelry, Watch, Clock, Silverware, Silver Plated Ware, Optical Goods, Precious Stone, Art Pottery, Bric-à-brac, Cut Glass and cognate lines of the Jewelry Industry.



The work is now nearing completion. We consider it will be the most valuable book that has ever been issued to the Jewelry trade.

It is a work which the retailer and wholesaler will immediately appreciate.

It will be a book of constant reference, and will be consulted more perhaps than any other book issued to the trade.

It will be a book of daily use.

It will be sold at a figure that will guarantee its rapid distribution.

In addition to illustrations of the various trade-marks and the names and the addresses of the firms to whom they belong, and the class of goods to which they appertain, the work will contain other interesting and valuable information bearing upon the subject of trade-marks.



Those firms who have as yet not sent electrotype, print or drawing of their trade-mark or trade-marks are requested to do so at the earliest possible moment.

Members of the Trade, Manufacturers, Wholesalers and Retailers should at once place their orders for

### “TRADE-MARKS OF THE JEWELRY AND KINDRED TRADES.”

\$1 per copy. Bound in Cloth. Payable now or upon delivery of Book. Detach order below and forward to the Jewelers' Circular Publishing Co., 189 Broadway, New York.



#### ADVANCE ORDER BLANK.

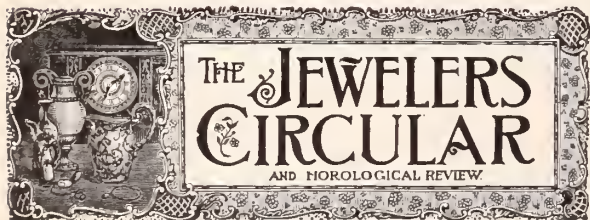

189 Broadway, New York.

1896

Please file this order for ..... copy of

“Trade-Marks of the Jewelry and Kindred Trades”

for which I agree to pay \$1.00 per copy, postage prepaid, upon delivery of book.

Name .....

Street ..... City ..... State .....

## Workshop Notes.

**Scarce Brass Alloys.**—Bristol brass (Prince metal), six parts copper, two zinc; Japanese brass (Sinchu), ten parts copper, five zinc; white brass, one part copper, eight zinc, one iron—very suitable for statue casts in place of bronze.

**Nickel-Plating.**—For nickel-plating we would recommend the Bunsen type of battery. Although the same battery can be used to good advantage in gold and silver plating, it would be more satisfactory to use a small battery for the two last named metals. Either of these batteries can be readily procured of dealers in electrical supplies at a cost varying from \$2.50 to \$3, and are better and cheaper than can be made at home. For experimental purposes the proportions for the plating solutions can be reduced to any quantity desired.

**To Clean Brass.**—The method prescribed for cleaning brass, and in use in all the U. S. arsenals, is claimed to be the best in the world. The plan is to make a mixture of one part common nitric acid and one-half part sulphuric acid, in a stone jar, having also ready a pail of fresh water and a box of sawdust. The articles to be treated are dipped into the acid, then thrown into the water, and finally rubbed with sawdust. This immediately changes them into a brilliant color. If the brass has become greasy, it is first dipped into a strong solution of potash and soda in warm water; this cuts the grease, so that the acid has full power to act.

**Rouge as Polishing Agent.**—Good coarse redstuff or sharp rouge cuts very quickly, if used properly with a hard, sharp steel polisher, and should be prepared like all polishing agents, on a hard steel block. The blocks set in round boxwood boxes (as used in England) are better than the square ones in tin cases, as the lid to the wooden ones fits better and excludes the air and dust. It is unwise to mix too much at a time, as, if the oil gets even a little thick, the rouge is useless. When it is mixed with oil, it should be well beaten up with burnisher, kept for this purpose, until it is quite smooth and of the consistency of paste. In mixing fine red rouge, the dust may be thrown away and the lumps only be used, as any dust mixed with it will scratch the work; this must be well beaten with the burnisher until it is quite smooth, and left a little thicker than the sharp rouge.

**Brass Finishing With Acids.**—Many articles of brass cannot readily be finished by the file or abrading substances, owing to the intricacies of their surfaces. Especially is this true of brass castings of an ornamental character. But a most elegant finish can be obtained by means of acid, which may be protected, if desired, by means of lacquer or varnish; the acid finish, however, is generally preferred without the addition of a varnish. If the work to be finished is greasy, it should be cleared by heating and dipping in acidulated water—vinegar and water, or washing soda in water—and then in clear water. The finishing bath may be either nitric acid two parts, water one part, or one part sal-am-

moniac, one part sulphuric acid, one part nitric acid, one part water; all by measure, and the sal-ammoniac to be dissolved in water until a saturated solution is obtained. The articles should not be allowed to remain in the acid more than ten seconds, then taken out, plunged into clear, cold water, then into soapy water, and then dried in hot sawdust.

## Correcting a Defective Cylinder Escapement.

**A**LTHOUGH the cylinder escapement is easiest to repair, many workmen do it in an unworkmanlike manner; and when, after having cleaned the watch, they find that it will not run as it should, they are compelled to do all their work over again. When you get a cylinder watch to clean and repair, do as follows:

Before you take the movement down, see whether the depthing of the escapement is too deep or shallow, and how the scape-wheel enters into the entrance. Then, after having observed the proportions of cylinder and escape-wheel, take out both. After having taken off the balance-spring from the cylinder, see whether the teeth of the wheel fit to the cylinder. The tooth must have in the cylinder just as much shake as the cylinder has between each tooth-space. An escape-wheel with short, stubby teeth, or teeth ruined by grinding and rounding by some botch, must be renewed at once, because a correct timing of the watch is out of the question, in spite of all painstaking.

If the cylinder of a watch left for repairs is worn at the entrance, do not at once commence to grind, because the operation will open the lips unduly wide. No matter how well the escapement with unduly wide cylinder lips is set in order, it can never be timed with anything like precision, because the tooth point reaches beyond the center of the cylinder, and the escape wheel draws this on. This defect is also frequently found in new watches, and the motion of the balance will then be slow and short. The error is easily found by enlarging the strength of the spring by pushing the fourth wheel; the balance will not then make longer vibrations as it should, but stop entirely. There is no other remedy than to replace the defective cylinder.

Next examine the pivots and jewel holes. When repolishing the pivots be very careful not to make them unequally thick. If a pivot is greatly worn, do not polish it by making it too thin and put in a new jewel hole, but make a new pivot of the size of the old. Watches with unequally thick pivots cannot be timed, because the changing of positions of the watch is responded to by differences of friction. When rounding the pivot make the end neither too pointed nor too flat.

The jewel-holes must be in good order and correctly fit the cylinder as well as the escape wheel, as otherwise the depthing would now be deeper, then shallower, according to the varying positions of the watch. The cap jewels also must be good, and lie firm and flat.

Then take the escape-wheel and scrutinize it closely with the magnifier. It will be found that among ten wheels there are at least nine, the teeth of which are broad or thick in front. Watches with such scape teeth cannot be timed, as the friction on the cylinder is unduly strong, in consequence of which the motion deteriorates largely even after a few weeks. It is necessary, therefore, to point the teeth by grinding about two-thirds of the lifting from above and toward the point until this is as fine as a hair. Next, polish the lifting faces with the rounding polishing file. When finished neither corner nor face must be seen in the lifting, even with a strong magnifier, but the latter must present a clean curve from one end to the other. Also take care, when grinding one tooth, not to touch the next with the stone, because, if even a small portion is ground away from the back of only one tooth, the whole escape wheel is ruined.

When, now, the teeth have been clearly pointed in the described manner, pass the rounding polishing file a few times around each tooth-point, so that in place of the sharp point you have a nicely polished rounding, to be noticed however only with a strong magnifier.

If the teeth of a cylinder escape-wheel are too long, shorten them in front, never on the back, and then observe the directions just given in pointing them.

Examine whether the wheel runs flat; if not, place wheel and cylinder first into the movement, and be guided by the entrance, whether the low places should be raised, or whether it is better to depress the high.

This will give a moderate shake to cylinder and wheel. The entrance must be so that the cylinder can never touch the stalk of the escape teeth even with its oil. The depth of the depthing must stand so that every tooth drops securely upon locking. If, on the contrary, the depthing is placed even a little too deep, the watch can be timed just as little as when the depthing is too shallow or the cylinder opened too wide. When next the balance is well poised and the balance-spring in good order, the watch, when delivered, will give thorough satisfaction as far as it is possible with a cylinder escapement.

It can occur that the vibration of the balance is too long. This, also, is a defect. If in such a watch the mainspring is not too strong, turn down the height of the escape-wheel, so that it has less lifting. For this use a small piece of a very soft spring blade with a little oil and oilstone dust and apply it against the teeth of the revolving wheel. After a few revolutions of the fly-wheel the lifting is already smaller; then polish the teeth with rouge or diamantine in the same manner.

The contract for furnishing the Senior German favors at Yale University has been given to Black, Starr & Frost, New York. The ladies' souvenir favors will be silver belt buckles representing the Yale seal; the gentlemen's silver match boxes.

# NEW ORNAMENTS

... IN ...

## STERLING SILVER.



Many Designs in

Galleries, Belt Buckles,  
Belt Slides **AND** Belt Fastenings,

ALWAYS SOMETHING NEW.

### THOMAS W. LIND,

67 Friendship Street,

Manufacturer of  
JEWELERS' FINDINGS.

PROVIDENCE, R. I.

# AJAX INSULATORS.

PATENTED OCTOBER 28, 1889.

THEY are Cheap; THEY Reduce Wear and Tear of the Case;  
THEY Protect from all Ordinary Magnetic Influences.

Perfect in  
Action.  
Convenient  
in Use.



Educate  
Your Customers  
by Talking  
up  
Ajax Watch  
Insulators.

MADE IN ALL SIZES, OPEN FACE AND HUNTING.  
FOR SALE BY JOBBERS.

MANUFACTURED BY

## The Newark Watch Case Material Co.

19 WARD STREET, NEWARK, N. J.

ESTABLISHED HALF A CENTURY.

# MARVIN'S

FIRE & BURGLAR

# SAFES

HAVE MANY PATENTED IMPROVEMENTS  
NOT FOUND IN OTHER MAKES  
THAT WILL WELL REPAY AN  
**INVESTIGATION**  
BY THOSE WHO DESIRE TO SECURE  
**THE BEST SAFE**  
MARVIN SAFE CO.

12 PARK PLACE, NEW YORK.

## THE SWAN FOUNTAIN PEN

Reputation World Wide.  
Made upon Distinct Principles.  
Is a Compressed Air Pump.  
Simply Wet the Insides to Provoke  
an Energy.

W. W. Stewart, Inventor and Patentee.

A variety of Styles and Prices

- 3 Sizes Safety Swans.
- 3 Sizes Self-filling Swans.
- 3 Sizes Adjustable Feed Swans.

### MABIE, TODD & BARD,

NEW YORK AND LONDON.

## The Bonner Combination

RING, STUD and SCARF PIN.  
A Long Screw and a Round Bezel.

Send for Selection Package

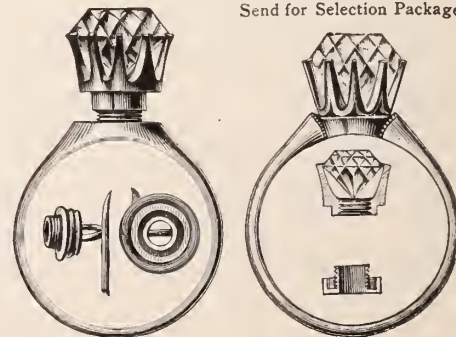

### BONNER, RICH & CO.,

41 & 43 Maiden Lane, NEW YORK,  
604 Champlain Building, CHICAGO.





## The Rambler's Notes.

WHAT THE RAMBLER SAW AND HEARD AMONG THE DEALERS IN ART POTTERY, CUT GLASS, BRONZES, ETC.

AFTER waiting nearly three years, L. Straus & Sons have at length received the diploma and medal awarded them for their beautiful exhibit of cut glass at the World's Columbian Exposition. The diploma which speaks in high terms of L. Straus & Sons' exhibit is now to be seen in the firm's art glass warerooms, 42-48 Warren St., New York. The wording of the award which is signed by C. Colne, individual judge, is as follows: "The designs are original, very handsome and most skillfully executed. The cutting is bold, the sharp angles are well kept, the workmanship is perfect and the polish excellent. There are a number of very large pieces which are finely cut, in itself an evidence of skillful workmanship as pieces of such sizes are very difficult to handle. Among others may be mentioned a 12 ft. candelabrum with 42 arms; a large druggist's bottle diamond cut; a punch set, with an egg shaped bowl; an epergne having four horizontal dishes and a top vase, and also two large heavy punch bowls. All this work calls forth the highest tributes to American skill and originality in conception. For original, artistic and tasteful designs, fine and regular workmanship in cutting, excellent polish and general perfection."

AMONG the seasonable articles recently received by Charles Ahrenfeldt & Son, 52 Murray St., New York, are fine assortments of pots and pedestals. In the German and Austrian wares there are many sizes of palm and other garden pots, and urns with stands, showing elaborate decorations, while a beautiful collection of extra large pots is shown in Royal Bonn and Bonn Delft.

GREAT OPPORTUNITY TO BUY CLOCKS AT LOW PRICES.

THE receiver's sale of the stock of the Chas. Jacques Clock Co., 22 Cortlandt St., New York, which is now in progress, affords the trade an opportunity seldom offered

to get new goods at inviting prices. The stock of this firm, which the receiver is closing out, contains some of the latest Paris novelties in porcelain and gilt, bronze and other clocks, all fresh importations this Spring, together with a large stock of Elliot chime clocks and a fine assortment of hall clocks.

FALL PREPARATIONS BY LAZARUS, ROSENFELD & LEHMANN.

LAZARUS, Rosenfeld & Lehmann are now clearing out their import samples in order to make room for the new Fall goods which have commenced to arrive. The firm are now making extensive preparations for the Fall trade, and in this connection are about to make sweeping changes in their stores, 58-62 Murray St., New York. Their warerooms will be entirely rearranged, redecorated and renovated so as to afford greater facilities to their patrons.

THE RAMBLER.

## Historic Delft Ware.

A HISTORICAL set of old English blue and white Delft ware was made by William Ridgway in 1811, in Staffordshire, England, the subject being "The Beauties of America." The most famous buildings of the time are depicted, among them being: The Capitol, at Washington; Octagon Church, Boston; City Hall, New York; Atheneum, Boston; Library, Philadelphia; Pennsylvania Hospital, Philadelphia; Exchange, Charleston; Bank, Savannah; Canot House, Boston; Mount Vernon; Deaf and Dumb Asylum, Hartford; Almshouse, New York; State House, Boston; Hospital, Boston.

The pieces were purchased by Mr. McHugh from Miss Eleanor H. Frick, librarian of the Pratt Institute, Brooklyn. The ware has been in the possession of the Frick family since 1816, and had never been moved from the family homestead in Danville, Pa., until sent to Mr. McHugh. The excellent condition of the various pieces is accounted for by the fact that no one of them ever found its way to the kitchen during its term of service of 30 years. So highly was the ware prized that the washing of these dishes was done in the dining-room after meals.

About 1845 blue and white ware became distinctly old-fashioned, and these pieces were carefully packed away in the family garret,

only to be discovered among other relics the past year, in season for the revived interest in blue Delft.

The story of this set, which is believed to be the only one in existence, was communicated to Mr. McHugh, and its immediate purchase for his collection was the result.

## The Ring California Gave Pierce.

ONE of the most curious as well as most valuable of American rings was presented to President Pierce in 1852 by the citizens of California, says the *San Francisco Chronicle*. It is of massive gold, weighing upward of a pound; the circular portion is cut into squares, which are embellished with beautifully executed designs, the entire group presenting a pictorial history of California. The seal of the ring is really a lid, which swings upon a hinge, and is covered with the arms of the State of California, surmounted by the Stars and Stripes. Underneath is a square box divided by bars of gold into nine separate compartments, each containing a pure specimen of the varieties of ore found in the country. On the inside is the following inscription: "Presented to Franklin Pierce, the fourteenth President of the United States."

SOLOMON DIDN'T KNOW.

King Solomon was the wisest man that ever lived. People came from miles around just to look at the receptacle of so much wisdom. One day a young man came to him and knelt before his throne.

"O King, live forever," said the young man. "I am in love. I bought the object of my affection a diamond pin. She allowed me to kiss her, and later accidentally called me 'dear,' and blushed and apologized. Does she care anything for me?"

"I don't know," said King Solomon.—*Chicago Tribune*.

I. G. Walestead, Cavalier, N. Dak., has given a chattel mortgage on his jewelry business for \$174.

Geo. E. Seibert has given a bill of sale of his jewelry business in Cedar Falls, Ia., for \$2,829.

J. Jaskulek, of the Northwestern Watch & Jewelry Co., Portland, Ore., has been garrisoned for \$904.

**New Spring Winder With Improvements.**

THERE are so many new, and novel, and improved, &c., bow-frasing machines, some of them quite practical, on the market, that one should think it barely possible inventive talent could devise another essentially differing from the rest. And yet THE CIRCULAR is from time to time called upon

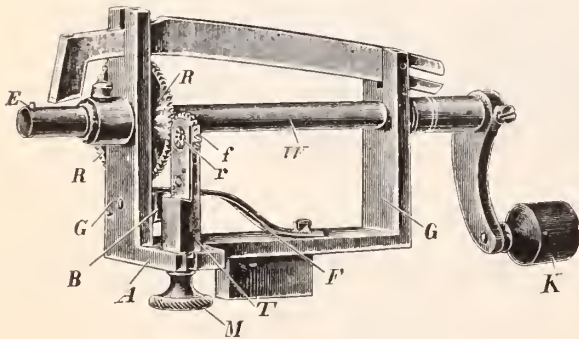

to prove the fallacy of this presumption. For instance, Robert Steurer, of Chaux-de-fonds, Switzerland, has united two separate machines into one that is quite practical: a spring-winder, which, by a few auxiliaries, can be altered readily into a bow-frasing machine. The frame G of the spring-winder has for this purpose been furnished with a projection A to which by means of the set-screw M a support T composed of two bridges is fastened, in the upper part of which a small steel wheel, f lies in bearing.

The axis of this steel wheel is chamfered out in a slightly conical shape, so that it may serve for the reception of the low fraise r, which is simply pressed from the left into the chamfering, and finally pressed out again from the other side. The projection A has a

slot, through which passes the thread of the screw M, which facilitates the rapid taking out of the support T from the frame, by opening the set-screw M only one half turn.

Upon the arbor W of the spring-winder is, by means of a large brass shell, screwed on a large steel wheel, R, which stands in depthing with the small steel wheel f, while at the same time, when the spring-winder is used, it takes the place of the ratchet wheel for the click B. The number of teeth of the wheel R is proportioned to that of the wheel f, as 3:1; at every revolution of the crank K, therefore, the fraise f, revolves three times.

When using the fraising arrangement, the click-spring F is placed in the center of the click B, so that it is out of depthing with the steel wheel R. The disposition of the spring-winder is of the usual kind; the little machine is furnished with four different sets, E, of 6, 5, 4, and 3 millimeters in diameter, as well as with seven bow fraisers, of the latter of which one serves for fraising male centers, while the other six are used for fraising the ends of bow-rings.

**The Dyeing of Jewels.**

THE dealer in precious stones as well as the jeweler must constantly exercise great vigilance lest he should be deceived by dyed jewels, especially diamonds, the trickery in the production of which has advanced almost to the state of art, even the dealer with an experience of years being occasionally deceived. Before entering more fully into the details of this dyeing, which is practiced with aniline colors, it is in place to state that hitherto it has been impossible to impart to

paste the pure color of certain jewels; for instance, a pure ruby red or emerald green cannot be produced by melting color substances, any paste prepared in this manner being of an "off" color and easily recognizable by an expert.

The following remarks do not apply to imitation jewels used on the stage or by workers in bronze, etc., but only to those handled and treated by the jeweler, namely the well known doublets. As is known the doublet is an imitation of a jewel, the lower part, the culet, of which is an appropriately colored paste, while the upper part, the table, is an inferior genuine gem, being fastened upon the culet with a water-clear cement. These doublets, however, can readily be distinguished by the expert.

Since solutions of aniline dyes possess the property of imparting to genuine jewels as well as glass paste, a deep, rich color, if the jewels be long enough immersed in the dyes, and since they possess the property of imparting precisely the characteristic color of a genuine jewel, the swindler has it not only in his power to dye cut glass paste, but also inferior cut gems, the color of ruby, emerald or sapphire, since fuchsine is of the handsomest ruby red shade, while bleu de Paris imitates absolutely that of the sapphire, and aniline green that of the emerald. Such a fraud can be made still more complicated by using genuine off colored rubies, sapphires or emeralds, and dyeing them with the corresponding aniline dyes, thereby raising their value tenfold. It is exceedingly difficult to recognize this fraud, because the color of such a well corroded jewel can no longer be washed off even with hot water; only the bleaching power of sunlight might after a time assist in revealing the swindle. The price of the ruby is much higher than that of the yellow Cape diamond, but if the latter is dyed deep ruby red, it will become a ruby diamond of a fire not possessed by even the best ruby, and such a jewel will excite the admiration of all lovers of jewelry and will command a high price. This fraud is at present being worked in Europe for all it is worth.

**THE BRAND,**

The unquestionable brand,  
The brand of all brands,  
The first of all brands,  
The tried and true brand.

It's  
The



"ANCHOR" BRAND

**SILVER PLATED WARE.**

It counts for everything that's good and true and of artistic design in Silver Plated Ware.

No one else makes it. No one makes its equal.

FACTORIES:  
Hartford, Conn.  
Norwich, Conn.  
Taunton, Mass.

**WM. ROGERS  
MAN'F'G CO.,**  
Office and Salesrooms: Hartford, Conn.

**WOOD & HUGHES,  
STERLING SILVERWARE MANUFACTURERS**

New York Agents for the Derby Silver Co.,  
**FINE QUADRUPLE PLATED WARE,**  
No. 16 JOHN STREET, NEW YORK  
206 Kearney St., San Francisco, Cal.  
HASKELL & MUEGGE, Agents.

**CAMPBELL-METOALF SILVER CO.,  
SILVERSMITHS,**



ALL GOODS 925/1000 FINE.  
Factory, Providence, R. I. Offices, New York and San Francisco.

**JACOT & SON,**  
Importers and Manufacturers of  
**Musical Boxes,**  
39 Union Square, New York.

ARE always of **Standard Quality**, of **Newest Styles** and **Best Finish**.

They will always sell when anything will, and cost no more than those of doubtful reputation.

Don't wait for our travelers, but send direct to

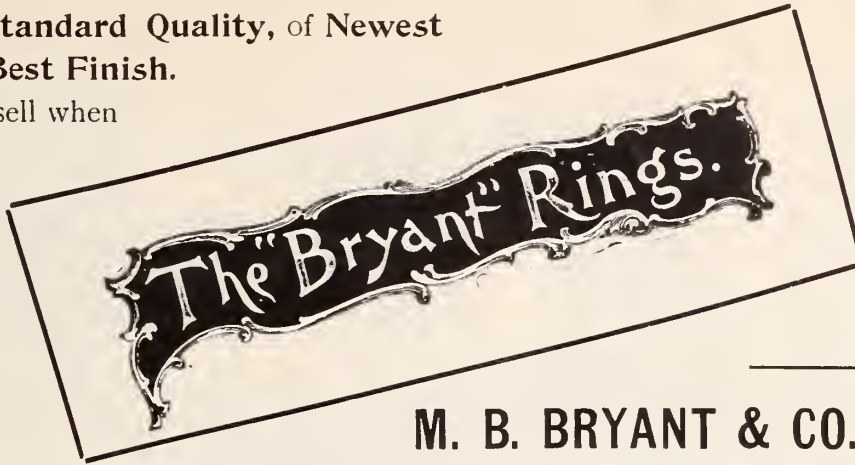

**Oldest Ring Makers in America.**

**M. B. BRYANT & CO.,** 10 Maiden Lane, N. Y.

### NYE'S SUPERFINE OILS.

Special grades for

CHRONOMETERS, WATCHES, CLOCKS, JEWELERS' LATHES, ETC., ETC.



NYE'S OILS acknowledged SUPERIOR TO ALL OTHERS.

WM. F. NYE, Manufacturer, New Bedford, Mass.

We carry the largest, finest and most complete line of Mounted Diamond Jewelry of any house in America.

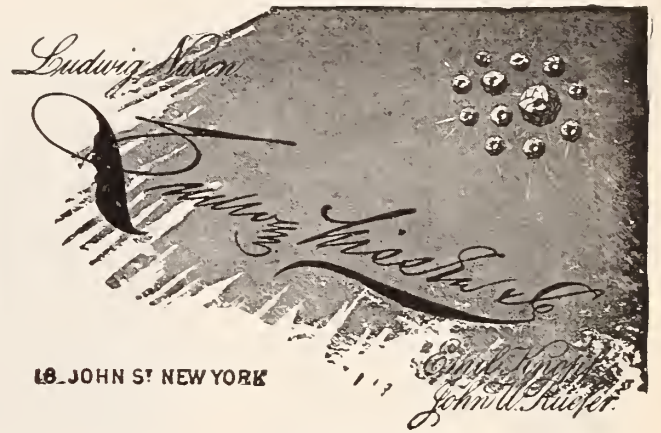

18 JOHN ST NEW YORK

### CROUCH & FITZGERALD.

Jewelry Trunks and Cases,

161 Broadway, Bet. Cortlandt and Liberty Sts., 688 B'way, 701 6th Ave., NEW YORK



No. 149

### KETCHAM & McDOUGALL,

MANUFACTURERS OF GOLD AND SILVER THIMBLES

ESTABLISHED 1832.



TRADE-MARK.

And the improved

Automatic Eye-Glass Reel.

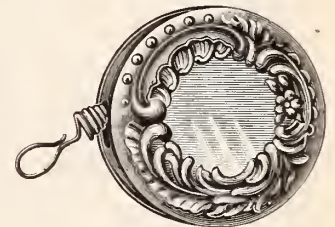

Pat'd Nov. 20, '94.

SEND FOR CATALOGUE C.

198 BROADWAY, NEW YORK.

ANY BOOK pertaining to the jewelry or kindred trades can be obtained from the JEWELERS' CIRCULAR PUB. CO., 189 B'way, N. Y. Send for Catalogue.

### AIKIN, LAMBERT & CO.,

MANUFACTURERS OF

FINE GOLD PENS, HOLDERS, PENCILS, TOOTH PICKS, and NOVELTIES.

PAUL E. WIRT FOUNTAIN PENS, at new and lower prices . . . . .  
MERCANTILE FOUNTAIN PENS, guaranteed to give satisfaction.

Catalogues with terms and discounts furnished to the trade.

BRANCH, 103 STATE STREET, - - - CHICAGO.

### AIKIN-LAMBERT JEWELRY CO.,

IMPORTERS OF

**DIAMONDS.**

JOBBERS IN

WATCHES, JEWELRY, CHAINS NOVELTIES, ETC.

LATEST DESIGNS.

LOWEST PRICES

19 MAIDEN LANE, NEW YORK.



**CYCLING PROGRESS  
EXEMPLIFIED.**

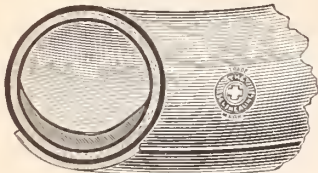

**THE WONDERFUL  
SELF-HEALING TIRES**

are single tube, finest rubber, finest wove Sea Island cotton fibre, re-enforced inside and outside on tread, and no better tire can possibly be made. They are fully guaranteed against all climatic changes, are the most resilient ever made, and when punctured instantly heal the wound of their own position.

THEY WEIGH NO MORE THAN OTHERS,  
COST NO MORE,  
AND ARE WORTH TEN TIMES MORE.  
—SEND FOR FIRE BOOKLET—

**Wm. H. CAHN, GENERAL MANAGER,**  
48 and 50 Maiden Lane, New York.

**BY EVERY TEST THEY ARE THE BEST,  
THE UNIVERSAL FAVORITES.**



**SUPERB  
Olympic  
BICYCLES**

For sale by more than 2,000  
Jewelers, and constructed to meet  
the demand for finest quality.  
For Adults and Juveniles.

**SEND FOR EXQUISITE  
CATALOGUE.**

Top Grade "Olympics" have SELF-  
HEALING TIRES.

Olympic Cycle Mfg. Co.,  
N. Y. Office: 35 LIBERTY STREET

General Jobbing Ag'ts, S. F. MYERS & CO.,  
WHOLESALE JEWELERS, Myer's Building, New York

**RECEIVER'S SALE!**

**TRADE OPPORTUNITY.**

Entire Stock of

**CHAS. JACQUES CLOCK CO.,**

22 Cortlandt St., New York,

**...Must Be Closed Out...**

Latest Paris Novelties,  
all New Importations  
of this Spring

Together with LARGE STOCK of

**ELLIOT CHIME CLOCKS,**

And a Fine Line of Other

**HALL CLOCKS.**

By order of

**ALBERT C. WALL, Esq.,**

Receiver.

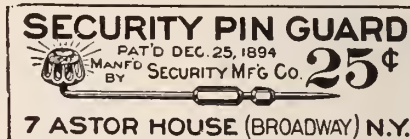

7 ASTOR HOUSE (BROADWAY) N.Y.  
85c. doz. Net Cash Discount to Jobbers

**BAWO & DOTTER,**

26-32 BARCLAY ST.

NEW YORK.

P. O. Box 1872.

NO LARGER STOCK  
OF

**HALL  
CLOCKS**

IS SHOWN IN  
THIS CITY.

Large Stock  
OF  
MOVEMENTS.

NEW DESIGNS  
IN CASES.



**DUBOIS WATCH CASE CO.**

TRADE MARK REGISTERED.

FINE HAND MADE  
**SOLID GOLD CASES.**

A PRIDE TO THE MAKER,  
DEALER & WEARER.

**L. LELONG & BRO.,**

GOLD AND SILVER

Refiners, Assayers and Sweep Smelters,

◁ SOUTHWEST CORNER HALSEY AND MARSHALL STREETS, ▷

**NEWARK, N. J.**

SWEEPINGS A SPECIALTY.

**STERLING**

SHEET AND WIRE SUPPLIED ALL SIZES.

**J. SCHAWEL & CO.,**

Gold, Silver and Platinum Refiners.

29 John Street, N. Y.

ALBERT LORSCH.

ALFRED KROWER

**ALBERT LORSCH & Co.,**

LORSCH BUILDING

37 & 39 Maiden Lane,

NEW YORK.



167 Weybosset St.,

PROVIDENCE, R. I.

IMPORTERS OF DIAMONDS, RUBIES, EMERALDS, ETC.,  
AND IMITATION STONES THEREOF.

•• Fine Miniatures on Ivory and Enameled Paintings. ••

**X RAYS**

are not needed to see the Xtraordinary merit of the Royal Clusters. The most Xacting Xaminer can find no fault with the Royal Cluster. It is Xactly what your customer has wanted for years. It is a mounting of Xceptional merit, finished with Xtreme care and Xactness.

**HENRY E. OPPENHEIMER & CO., 14 MAIDEN LANE, NEW YORK.**



Copyright by THE JEWELERS' CIRCULAR PUB. CO. 189 Broadway, New York. Entered at the Post Office in N. Y. as second class matter.

VOL. XXXII. NEW YORK, WEDNESDAY, JUNE 17, 1896. NO. 20.

THE ART OF THE MEDALLEUR.

THE art of the medalleur is destined to thrive when its disciples are filled with ardor for its advancement. That such is true is evinced by the good work recently produced by many medalleurs, among which is to be noted the noble Depew Medal, executed by the comparatively unknown medalleur, Victor O. Brenner, of New York. The accompanying illustrations are almost self-asserting of the artistic merit of the medal. It is the result of Mr. Brenner's perseverant application of his leisure moments, he being impelled towards its conception and completion by purely æsthetic motives. Being thus produced it has gained its reward, by meriting the praise of all connoisseurs. Though the artist never felt the influence of an art school, yet he was taught by his father the rudiments of the art wherewith he has accomplished what would be the pride of many an art academy.

The obverse of the medal presents an admirable bust of Dr. Depew with the inscription "Dr. Chauncey M. Depew, born April 1834." The detailed features of the portrait are skilfully wrought. The reverse presents a wealth of design and masterly execution. On a pile of rugged rocks sits Hermes, the stern guide of commerce. At his side is figured a classic Greek woman draped in a softly entwining veiling. Lovingly appealing, and with scroll in hand, she forms an admirable symbol of persuasion or eloquence. Vegetation springing forth about them is the embodiment of prosperity and cheer. The vivid de-

scription of an advancing train with all the intricate details of the engine forms an active and significant back-ground. From amidst the puffing smoke Columbia is seen quietly to ascend, as if to pronounce benison on the admirable characteristics of the famous orator. Beneath the figure is the inscription: "Pride of Columbia, Son of Commerce and Eloquence." In its entirety the medal is as happy a conception as is its subject. Mr. Brenner's friends, not content that this work of beauty should lie dormant in the art

ers in Paris are executing orders for this expensive fad. The process of engraving a diamond is an exceedingly lengthy one. The cost is proportionately great.

Hitherto it has been considered impossible to engrave a diamond, because no tool can be found hard enough to cut the stone. The use of electricity, however, rendered this possible. An electric motor of very high speed actuates a flexible shaft to the end of which is attached the tiny cutting tool, loaded with diamond dust. The diamond is firmly set in a bed of lead and the engraver works the freely-moving shaft in any direction necessary, like a dentist's drill. He can thus cut any pattern in a diamond by the little tool, which revolves at an enormous speed. This is reversing the usual process of cutting a diamond. The lapidary's wheel rotates on a fixed axis, while he moves



OBVERSE.



REVERSE.

THE DEPEW MEDAL—DESIGNED AND MADE BY V. O. BRENNER.

society's cabinet, where the artist will deposit the first impression, have suggested that he lend his dies for the purpose of striking souvenirs for mementos of occasions rendered memorable through Dr. Depew's participation. Mr. Brenner will act upon the suggestion, and thus will be insured to him recognition of his artistic production.

Engraved Diamonds a Fad.

THE newest kind of jewel is an engraved diamond. Several of the swell jewel-

the diamond around. This method is entirely too clumsy for the delicate process of engraving, so the diamond is fixed and the tool revolved at the tremendous speed which can be given by an electric motor. The operator can then see just exactly what he is doing. Only flat or table diamonds can be engraved.

A prominent Parisian jeweler has turned out a bicycle scarf pin made out of two single diamonds. The result is an exact representation of a bicycle in miniature, made entirely of diamonds.—New York World.

Sleeve links set with olivines and brilliants are exceedingly tasteful.

# KENT & STANLEY CO., LTD.,

## JEWELERS AND SILVERSMITHS,

### SEAMLESS GOLD FILLED CHAINS, JEWELRY, SILVER NOVELTIES.

NEW YORK OFFICE,  
21 and 23 Maiden Lane.



BOSTON OFFICE,  
403 Washington Street,

FACTORY, PROVIDENCE, R. I.

## NEW DESIGNS IN ALL LINES.

ALL OUR SILVER GOODS ARE GUARANTEED 925-1000 FINE.

### THE SPENCER OPTICAL INSTITUTE

THE RECOGNIZED OPTICAL SCHOOL FOR BUSINESS MEN

OUR COURSE PRACTICAL COMPREHENSIVE NONCLASSICAL IN THEORETICAL AND APPLIED OPTICS

SEND FOR APPLICATION BLANK & PROSPECTUS. CLASSES CONVEENE 1ST TUES. EACH MONTH  
SPENCER OPTICAL MANUFACTURING CO. 15 MAIDEN LANE . N. Y.

OUR STUDENTS ARE THE SUCCESSFUL OPTICANS

### BAND RING MOUNTING



DESIGN PATENTED  
Sept. 24,  
1895.



**CHARLES KNAPP,**  
MANUFACTURING JEWELER,

41 & 43 Maiden Lane, New York.  
SPECIALTY: SUPERIOR LADIES' and CHILDREN'S RINGS



### CHOICE PAPERS

## PARTICULAR ATTENTION

IS CALLED TO THE NEAT AND RICH  
STYLE OF OUR BOXING. OUR GOODS  
LOOK HANDSOMELY ON THE SHELF  
AND THE QUALITY ATTRACTS THE  
PURCHASER.

TRY THEM.

**PARSONS & GREENE CO.,**  
MANUFACTURING STATIONERS,  
HOLYOKE, MASS.

# Intrinsic merit

combined with low prices, makes Cahoone's line for the coming season the most attractive ever offered to the trade.



## Cahoone's rings

this year are shown in a host of beautiful designs. Particular attention is called to the Imitation Rose Diamond and Opal Combination Rings. Sold by all leading jobbers.

GEO. H. CAHOONE & CO., Kent & Stanley Building, Providence, R. I.  
N. Y. OFFICE, 21 MAIDEN LANE.



### The STATIONERS' ENGRAVING CO.,

98 TO 102 NASSAU STREET, NEW YORK.

MAKERS OF

WEDDING INVITATIONS, RECEPTION AND VISITING CARDS

of the Best Quality, which are offered to Jewelers of recognized standing only.

Trade Mark 'SILVER WHITE,' registered.

# Buy "The Best"



THE  
"Dueber  
Special"  
BICYCLE.

MAYSVILLE, KY., April 24, 1896.

Dueber Watch Case Mfg. Co., Canton, O.

Dear Sirs: The wheel came all right, and in fact exceeds my expectations. I have ridden the different high grade wheels for twenty years, and find this the easiest running wheel I have ever been on. Yours,

JOHN BALLENGER.

CHICAGO, ILL., April 23, 1896.

Dueber Watch Works, Canton, O.

Gentlemen: After a careful and critical examination of the "Dueber Special" Bicycle, I have no hesitancy in recommending it as a first-class wheel in every respect and I consider it the best wheel I have ever seen. The extreme care bestowed upon the fitting and finish of all parts, will alone recommend it to the watch making fraternity, who as a rule, are critical in these respects. The "Dueber Special" ranks with, if it does not surpass the highest grade wheels on the market. I see no reason why it should not have an enormous sale.

Very respectfully,

GEO. K. HAZLITT.



# Standard Sterling Silver Goods.

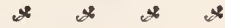

## Belts,

LEATHER, GILT,  
SILVER AND  
SILK WEBBING.

## Waist Sets,

Sleeve Links,  
Hat Pins,

IN

Sterling Silver

AND

Rolled Gold Plate.

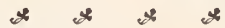

600 Useful Articles

IN

Sterling Silver.



# Foster & Bailey,

Providence, R. I.

NEW YORK,  
SAMPLES ONLY.

CHICAGO,  
SAMPLES ONLY.

### The Shah's Jewels.

It is at Ghoum, one of the holy towns of Persia, in the mosque sheltering the tombs of the previous Shahs belonging to the actual dynasty, that the remains of Nasr-ed-Din have

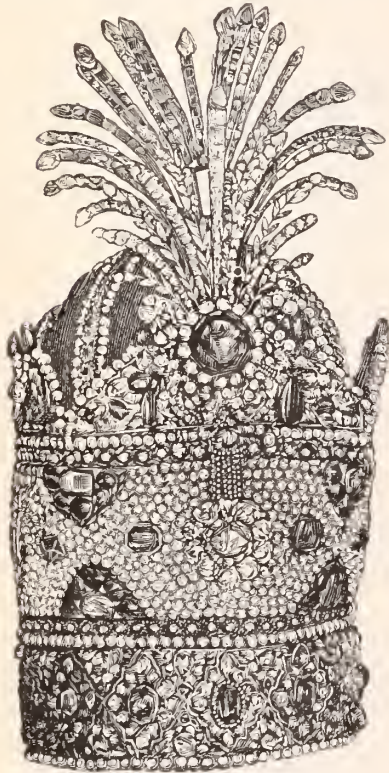

THE SHAH OF PERSIA'S CROWN.

been deposited. This sanctuary is most gorgeously decorated; its portals and domes are covered with sheets of gold, and the tombs are surrounded with massive silver railings.

The Shah's private jewels have been valued at 300,000,000 francs and include a big diamond known as the Darya-i-Nur; the Peacock

throne, encrusted with rubies and diamonds to the amount of 103,000,000 francs, which Nadar Shah carried off from Delhi, and a globe of jewels worth 25,000,000 francs. The Shah's crown is of the shape of a pot. It is embroidered with pearls and adorned with splendid gems. At the top is an enormous stone bound with pearls from which shoots up, fan like, a magnificent diamond aigrette.

The jewels of the late Shah, says the *Pall Mall Gazette*, are the greatest sight in their way that the world can show, and are worth several millions. The Kaianian crown is shaped like a flower pot with the small end open and the other closed, having at the top an uncut flawless ruby as big as a hen's egg. Two Persian lambskin caps are adorned with splendid aigrettes of diamonds, and there are gauntlets and belts innumerable covered with pearls and diamonds, the handsomest being the Kaianian belt, about a foot deep, weighing 18 pounds, one dazzling mass of diamonds, pearls, emeralds and rubies. Drinking bowls studded with jewels; swords, one or two of which are worth a quarter of a million each; epaulettes of diamonds, and armlets so contrived that the brilliants revolve and keep up an ever-changing scintillation, seem to realize the wonders revealed by Aladdin's lamp in the cave. There are dresses embroidered thickly with jewels; trays of pearl, ruby and emerald necklaces, and hundreds of diamond, ruby and turquoise rings.

The first place among the gems belongs to the famous Darya-i-Nur, or Sea of Light, sister diamond to our Punjab trophy, Kuh-i-Nur. It is an inch and a half long, an inch broad, and three-eighths of an inch thick. The inscription of Fath Ali Shah's name on one side reduced the value of the stone incalculably. As Yahya Khan said: "Deux millions! mais, deux millions de quoi—de francs, de piastres, que

sais-je?" It is not very brilliant, but it has a wondrous history. The Persians say that the Sea of Light and the Mountain of Light were jewels in the sword of Afrasiab, who lived 3,000 years B. C. Rustem took them from Afrasiab, and they continued in the crown of Persia till they were carried away by Timur, from whom they descended to Muhammad Shah, King of Delhi, and were brought by Nadiar from India. When he was slain, Ahmed Shah Abdalli carried off the Kuh-i-Nur, which descended to Shah Shuja, and was taken from him by Ranjit Singh; but the Darya-i-Nur remained in Persia.

Among the rings is one in which is set the famous Pitt diamond sent by George IV. to Fath Ali Shah. Sir H. Sutherland used to tell the story of the acceptance of this gift. A Persian nobleman had been sent from Teheran to Sir H. Jones to stop him from going there, the French influence being all-powerful at that time. Sir Harford Jones argued in vain with the Persian Khan, who remained unimpressed; and finally he said, "Well, if it must be so, I will return to my country and give up the hope of making my countenance while in the presence of the Shah. But this must return with me," and he drew the ring from his waistcoat pocket.

The Khan was breathless with pleased surprise for a moment then shouted, "Stop, stop! Elchi; may your condescending kindness increase! This alters the matter. I will dispatch a message to the heaven-resembling threshold of the Asylum of the World. I swear by your head you will be received with all honor. Mashallah! It is not every one that has diamonds like the Inglis."

The result was that Sir Harford entered Teheran by one gate as Gen. Gardanne made a hasty and hastened exit by the other. Another enormous diamond is the Taj-i-Huma, or Diadem of the Phoenix, as big as the top of a man's thumb. There are sapphires as big

## DORFLINGER'S AMERICAN

## CUT GLASS.

915 BROADWAY  
36 MURRAY ST.  
NEW YORK.



### Fox & Stendicke,

Manufacturing  
Opticians,

61 Fulton St.,  
New York.

Javal, Schiötz  
Ophthalmometers,  
Phorometers, Skia-  
scopic Appartus,  
etc., etc.

Send for Price List.

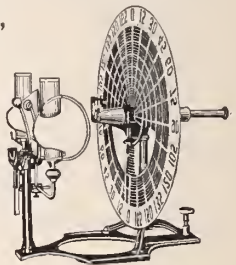

**RAZZLE RINGS**  
MADE BY HENRY C. HASKELL, N.Y.

Send  
For  
New  
Price  
List.

HENRY C. HASKELL,  
11 John St., New York.

### AMERICAN WATCH CASE CO.,

11 JOHN STREET, NEW YORK.

Manufacturers of FINE SOLID GOLD CASES.

Sold DIRECT to  
the RETAIL TRADE only.

**A.W.C.CO**

**O. NEWMAN,**  
Gold and Silver Electro-Plater,  
Etruscan Coloring a Specialty.  
WATCH CASE POLISHING.

75 Nassau St., Room 8 Rear Building, New York.



# IMPORTANT.

## The United States Circuit Court of Appeals

has decided that the Colby patent for pendant setting Watch Cases is invalid, and from this decision there is no appeal.

We are, therefore, the only manufacturers and ours the only valid pendant set device used in the manufacture of pendant setting Watch Cases.

In answer to some inquiries made of us, we wish to say we do not manufacture a pendant setting Watch Case for the new model 16 size Elgin Watch movement.

**The Dueber Watch Case Mfg. Co.,**  
CANTON, OHIO.

**CROUCH & FITZGERALD,**



**Jewelry Trunks  
and Cases,**

161  
Broadway,  
Bet. Cortlandt and  
Liberty Sts.,  
688 B'way,  
701 6th Ave.,  
NEW YORK

**HENRY FERA,**

IMPORTER AND CUTTER OF

**DIAMONDS**

PRESCOTT BUILDING,

65 Nassau St. cor. John NEW YORK.

FACTORY

60 Fulton St., NEW YORK.

Cutting for the Trade a Specialty,

## NEW ORNAMENTS

... IN ...

## STERLING SILVER.

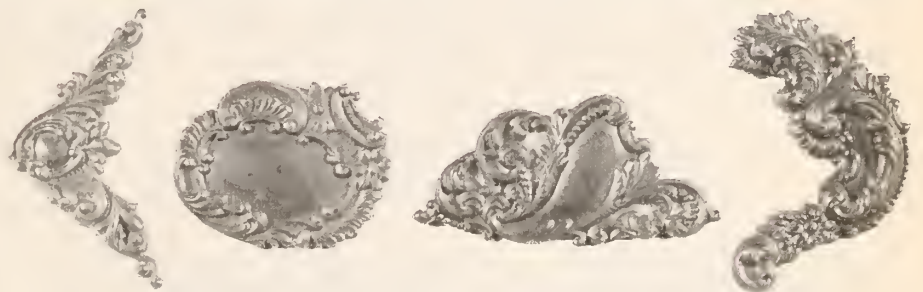

Many Designs in

Galleries, Belt Buckles,  
Belt Slides AND Belt Fastenings,

ALWAYS SOMETHING NEW.

**THOMAS W. LIND,**

67 Friendship Street,

Manufacturer of

**JEWELERS' FINDINGS.**

PROVIDENCE, R. I.

**DIAMONDS.**  
**Wm. S. Hedges & Co.,**  
 IMPORTERS OF  
 Diamonds and Precious Stones.  
 DIAMOND JEWELRY.  
 170 Broadway, New York.  
 22 Holborn Viaduct, London.

**Alfred H. Smith & Co.,**

IMPORTERS

DIAMONDS

AND

PRECIOUS STONES,

182 BROADWAY, COR. JOHN STREET,  
 NEW YORK.

Venetian Building. 34 & 36 Washington St.  
 CHICAGO, ILL.

**Purchasers**

.. OF ..

**RARE GEMS,**

PRECIOUS STONES  
 AND ALL GOODS FOR  
 JEWELRY,

ADDRESS

**R. A. KIPLING, Paris,**  
**19 Rue Drouot, France.**

**L. BONET,**  
 ESTABLISHED 1866.

**PRECIOUS STONES,**  
 CAMEO PORTRAITS, WORKS OF ART,  
 927 BROADWAY NEW YORK.

DON'T FORGET THE JEWELERS' CIRCULAR PUBLISHING CO.'S BOOK LIST when in want of any technical book in the Jewelry or Kindred Trades.

**SCHULZ & RUDOLPH,**  
 IMPORTERS AND CUTTERS OF  
**DIAMONDS AND OTHER PRECIOUS STONES,**

(Successors to JOHN E. HYDE'S SONS.)

Sole Agents for The Celebrated Jules Jurgensen Watches.

28 JOHN ST. and 65 NASSAU ST., NEW YORK.

**The Bowden Rings**

ARE COMPLETE IN VARIETY, CORRECT  
 IN QUALITY AND PERFECT IN FINISH.  
 WE MAKE EVERY VARIETY OF FINGER  
 RINGS.

**J. B. BOWDEN & Co.,**  
 3 MAIDEN LANE,

 **NEW YORK**

BRANCH OFFICE :  
 206 KEARNY STREET  
 SAN FRANCISCO, CAL.

as marbles, and many rubies and pearls the size of nuts, and more than a hundred emeralds from half an inch square to an inch and three-quarters long and an inch broad. Besides the largest turquoise in the world, about four inches long, there is another of unique beauty, perfect in color, three-quarters of an inch long, and three-eighths of an inch broad.

In the sword scabbard, which is covered with diamonds, there is not a single stone smaller than the nail of a man's little finger. Lastly, there is an emerald the size of a walnut, covered with the names of Kings who have possessed it.

**Death of George L. Streeter.**

NEW HAVEN, Conn., June 10.—George L. Streeter, formerly a well known jeweler in this city, died suddenly yesterday at his home in East Orange, N. J. The cause of death was pneumonia.

Mr. Streeter was 30 years ago in the wholesale grocery business in this city, being the senior member of the firm of Streeter & Barrows. After a year or two he sold out and went into the jewelry business on Chapel St. below Union St. He was a practical jeweler. He later, for 10 or 15 years, occupied the store now occupied by S. Goodman & Co. About six years ago his health became poor and selling out his business here he removed to Fredericksburg, Va., for a change of climate. He remained there about two years. Finally his health becoming better he removed to East Orange, N. J., where he established a successful jewelry and art stationery business, which he was conducting at the time he was taken with his last illness.

Mr. Streeter was about 76 years of age, and leaves a wife but no children, although he had lost several.

**Nelson H. Davis' Insolvency Proceedings Ended.**

WORCESTER, Mass., June 11.—Before Judge William T. Forbes in the Court of Insolvency, yesterday, Nelson H. Davis, jeweler, 375 Main St., was given his discharge, his offer in composition of 25 cents having been accepted. Mr. Davis failed several weeks ago, owing about \$15,000. His liabilities amounted to \$6,000, and in the Court of Insolvency he offered 20 cents in composition. C. F. Stevens, representing several firms, objected to the offer. Two weeks ago, Blackmer & Vaughan, counsel for Mr. Davis, increased the offer to 25 cents. This has been accepted, and the business settled.

After Mr. Davis received his discharge he disposed of the business to William H. Robinson, of Worcester, Mass., and Herbert H. Hilton, of Boston. The new firm will conduct the business under the firm name of the Robinson-Hilton Co. Mr. Davis will undoubtedly start a new store soon.

Mr. Robinson has long been connected with the jewelry business. He started for himself in this city in 1867 and after 10 years went to New York. From there he went to Providence, and since returning to Worcester he had been associated with Mr. Davis nine years. He was receiver at the store from the

time of the failure until the settlement of the insolvency proceedings. Mr. Hilton has been in the jewelry business in Boston. He has come to Worcester to live and will be actively engaged in the business.

**Stockholders of the Elgin National Watch Co. Meet.**

CHICAGO, Ill., June 11.—The annual meeting of the stockholders of the Elgin National Watch Co. was held in Chicago yesterday forenoon. W. J. Gilbert, A. B. Church, G. D. Sherman, W. W. Sherwin and E. D. Waldron, of Elgin, were present. The annual reports of the officers were read and directors for the ensuing year chosen. They are T. M. Avery, Charles Fargo, C. H. Hulburd, George H. Laffin, O. S. A. Sprague, M. A. Ryerson and J. M. Cutter. All were re-elected excepting Benjamin Allen, J. M. Cutter being substituted for him.

The condition of the company has improved materially the past year, and the outlook for a further improvement this Fall is favorable.

**Latest Connecticut Corporation Returns.**

NEW HAVEN, Conn., June 12.—The latest corporation returns just announced officially are: J. D. Bergen Co., Meriden, capital \$60,000, real estate \$1,700, personal estate \$17,000, debts \$33,500, credits \$28,000.

Rogers & Bro., Waterbury, capital \$62,500, real estate \$25,000, personal estate \$100,000, debts \$25,000, credits \$125,000.

C. F. Monroe Co., Meriden, capital \$40,000, real estate \$11,339, personal estate \$36,390, debts \$30,419, credits \$22,691.

Eagle Sterling Co., Glastonbury, capital \$20,000, real estate \$6,049, personal estate \$26,081, debts \$15,189, credits \$3,059.

Bridgeport Brass Co., capital \$150,000, real estate \$100,000, personal estate \$250,000, debts \$165,000, credits \$100,000.

**Incorporation of the Russell Brothers Company.**

CINCINNATI, O., June 11.—The Russell Brothers Company, of this city, have incorporated with a capital stock of \$10,000 in single shares of \$100, for the dealing in all kinds of jewelry and fancy goods.

The promoters are Edw. F. Kurman, Andrew Earls and Catherine Russell.

The new eyeglass case which Levy, Dreyfus & Co., 9 and 11 Maiden Lane, New York, are now placing on the market, has a number of striking advantages. Thin metal is the material used for the body of the case. It is covered with leather and lined with velvet. The hinge is of metal and is very strong and durable. The clasp is a decidedly unique one; it does not project outside the case like a button or strap. Inside of the clasp and a part same is a small metal hook upon which are hung the glasses by their bow. This case is known as the "Perfect Protection" metal case. It is roomy enough to admit high offset nose-pieces, yet it is very compact.

ESTABLISHED 1840.

**RANDEL, BAREMORE & BILLINGS,**

IMPORTERS OF

**DIAMONDS,**

AND OTHER PRECIOUS STONES.

**FINE PEARLS A SPECIALTY.**

MANUFACTURERS OF

**DIAMOND JEWELRY**

A Large Stock of Fine Mounted Goods Constantly on Hand.  
Goods Sent on Approval and Insured in Transit.

Diamonds Cut, Recut and Repaired.

58 Nassau Street,  
29 Maiden Lane,  
NEW YORK.

1 Tulp Straat,  
AMSTERDAM.

1 St. Andrew's St.,  
Holborn Circus.  
LONDON E. C.

ESTABLISHED 1841.



**CARTER, HASTINGS & HOWE,**

MANUFACTURERS OF

**GOLD JEWELRY,**

**15 MAIDEN LANE, NEW YORK.**

A. CARTER,

C. E. HASTINGS,  
W. T. CARTER

G. R. HOWE  
W. T. COUCH

FACTORY, NEWARK, N. J.

**FERD. FUCHS & BROS.**

**SILVERSMITHS.**

MAKERS OF STERLING SILVERWARE,

808-310 Greenwich St., - New York

**HERMAN KOHLBUSCH, SR.**



Established 1859  
Manufacturer of  
FINE BALANCES  
AND WEIGHTS FOR  
EVERY PURPOSE  
where accuracy is  
required. 59 Nassau  
Street, cor.  
Maiden La. N. Y.  
Repairs (any make)  
promptly made.



**ALWAYS**

Ask to see  
our

**GOLD FILLED**

**WATCH CASES.**

**None Better**

and

**Few Equal.**

BATES & BACON  
"FAVORITE"  
14K

BATES & BACON  
"ROYAL"  
14K

BATES & BACON  
"PURITAN"  
14K



**HIGH GRADE.**



Agencies to Jewelers Only.



DISCOUNTS AND CATALOGUE  
ON APPLICATION.



**F. Kroeber Clock Co.,**

360 Broadway, New York.

SOLE AGENTS FOR THE  
JEWELRY TRADE.

FOR RELIABLE OPTICAL WORK  
SEND TO

JOS. FRIEDLANDER & BRO.,  
OPTICAL LENS GRINDERS,

9 MAIDEN LANE, NEW YORK.

SEND FOR DESCRIPTIVE CIRCULAR OF OUR FRAME AND LENS CABINET.

**WOOD & HUGHES,**  
**STERLING SILVERWARE MANUFACTURERS**  
New York Agents for the Derby Silver Co.,  
**FINE QUADRUPLE PLATED WARE,**  
No. 16 JOHN STREET, NEW YORK  
206 Kearney St., San Francisco, Cal.  
**HASKELL & MUEGGE, Agents.**

## CLASSES OF JEWELRY IN DEMAND IN VARIOUS PARTS OF THE COUNTRY.

Reported by "The Jewelers' Circular" Correspondents.

**Plated Ware, Silverware, Cut Glass, Waist Sets in Columbus, O.**

COLUMBUS, O., June 9.—Inquiry among the leading jewelers as to the style and class of goods sold at this time resulted as follows: Barnitz & Nunemacher report having sold a number of wedding presents and graduating presents. The sale of rings has been good. The sale of plated silverware is picking up.

F. F. Bonnet reports the sale of cut glass and silverware to be good. Wedding presents have been in demand. Haines & Oberer state the sale of waist and belt sets in gold and silver far exceeds the sale of all other lines of goods. M. Blauvelt is kept busy with the sale of waist and belt sets.

**Diamond Pendants, Enamel Watches and Buttons in Louisville, Ky.**

LOUISVILLE, Ky., June 10.—The Louisville jewelers report trade to be greatly improved in the last two weeks. There has been a good run on silver for June weddings, and a number of handsome diamond pendants have been sold. The small enamel watches and buttons are still selling well, with the usual run on belts and link buttons with blouse sets.

**Silverware, Silver Novelties and Ladies' Chatelaine Watches in Toronto, Can.**

TORONTO, Can., June 8.—The large number of fashionable and other weddings during the early days of the month have given a marked impetus to the local jewelry business. owing to the demand for wedding presents. The principal run is on silverware and sterling silver novelties. Purchases, though numerous, have not as a rule been costly, the tendency being toward comparatively inexpensive gifts. A line of ladies' chatelaine watches in gunmetal and silver is selling well. In anticipation of the Summer influx of tourists, Ambrose Kent & Sons show a neat Toronto souvenir spoon in enamel and silver gilt with the city coat-of-arms.

**Silverware Moving Freely in Detroit, Mich.**

DETROIT, MICH., June 10.—The demand for goods, such as there has been, has appeared to be along the same lines as previously reported. Shirt waist sets and belts of all descriptions and other Summer novelties have been in fair demand. The only noticeable difference is with silverware, which has moved quite freely.

**The Heavier Goods and Diamonds in Demand in Elmira, N. Y.**

ELMIRA, N. Y., June 10.—June being the month of weddings, jewelers are reporting an extensive trade in the heavier pieces, such as rich cut class, entire sets of silver, rare china, and not to say the least, diamonds. There is a fair trade in general stock.

The fair graduates also come in for their share of attention, which generally follows the line of dainty articles and souvenirs in sterling silver, there being every conceivable style displayed from which to make selection.

**Belts and Waist Sets the Call in Kansas City, Mo.**

KANSAS CITY, Mo., June 9.—Trade is quiet in Kansas City but still a good number of small sales are made. The chief demand is for ladies' small goods; sterling silver shirt waist sets are selling very fast. Quite a number of leather belts with plain sterling silver clasps are called for, while a good number of fancy silver and gold plated belts were sold early in the season. The chief demand now is for something cheaper and more plain.

**Real Tortoise Shell Ornaments in Much Demand in New Haven, Conn.**

NEW HAVEN, Conn., June 10.—New Haven jewelers report that articles specially in demand the present season are belts and buckles, cut glassware and the general field of articles specially suitable for wedding gifts. Real tortoise shell ornaments are also in much demand.

**Satisfactory Sales of Pottery and Art Goods in Lynchburg, Va.**

LYNCHBURG, Va., June 6.—The retail trade in this city report business quiet, though there have been considerable sales in waist sets and belts. The largest business done for the past month has been in college medals, emblems, etc., as this is the season of commencements. Owing to the favorable season for all classes of crops, a good outlook for Fall business is anticipated. High grade jewelry, diamonds, etc., are slow sale, except for wedding presents. Retail jewelers have had to contend with dry goods houses, which carry the commoner grades of belts, etc., and their trade has been cut into to a considerable extent by them. Some of the dealers have introduced the higher grades of pottery and art goods, and they are meeting with satisfactory results.

**Miniatures, Plaques, Silverware and Pendants in Cincinnati, O.**

CINCINNATI, O., June 9.—The demand in the jewelers' line in Cincinnati at the present time is somewhat of a varied nature. The High School commencements made a demand for presents for the graduates, and the jewelers came in for a large share. Clemens Hellebush, Clemens Oskamp, Frank Herschede and Thos. Lovell all report sales the past week to be largely in silver. Mr. Herschede says his largest sales have been in miniatures and fine plaques. At Hellebush's large pieces of silver, such as berry bowls, have been ordered for

weddings. Oskamp, Nolting & Co. have sold a number of beautiful pearl and diamond pendants.

The Arcade jewelers have sold during the past week many silver novelties. This is a thoroughfare for all the strangers that come to the city, and they invariably patronize one of the many jewelers who make such attractive displays. The waist sets business is subsiding with the jewelers. So many drygoods stores and notion houses have cut the prices in the cheap lines, that the patronage has drifted largely to these stores.

What the jeweler is now anxious about is the Summer trade. What are the manufacturers bringing out to meet this season? As yet they have brought out nothing new.

#### Silver Goods in Greatest Demand in Burlington, Ia.

BURLINGTON, Ia., June 9.—All sorts and descriptions of linkcuff buttons are being offered by Burlington jewelers this month. Sterling silver is by far in greatest demand, both in cuff buttons and shirt studs. Blouse sets also are rapid selling articles. Many new and original designs are shown both in silver and gold, but five of the former are sold to one of the latter.

#### Some Summer Goods Sold in New Bedford, Mass.

NEW BEDFORD, Mass., June 12.—Local jewelers are very generally unanimous in regard to the trade at present—there isn't much of it. The only trade of consequence is in Summer novelties such as buckles, belt sets or negligee costume trimmings, fancy mounted parasols, etc. Watches and high cost jewelry, gems and the like are selling very feebly.

There is perhaps one exception to this state of affairs. Henry B. Howland declares that business was never better and his trade is good in all lines. The hope is expressed that in Fall conditions will greatly improve. Mr. Howland's boom may be explained by the fact that he has just put in a new plate glass front of nearly double former capacity and makes a fine showing of goods. He says that since he added the front trade has increased fully one half.

#### Bicycling Pins and Chatelaine Watches in Providence, R. I.

PROVIDENCE, R. I., June 12.—Among the retail jewelers the principal business at present is in belts and waist sets, the former predominating. Every lady wants a belt and these dainty articles of adornment are to be obtained at any price from 25 cents to \$10. Novelties in pins for the lapel, especially those in any way suggesting or pertaining to cycling, are also much sought after and command good prices. Chatelaine watches with bow knots and fleur-de-lis bars are selling readily. Everything is in silver. The past week has seen an unusually brisk trade in silverware, both plated and solid, bric-à-brac and cut glassware and fine potteries. The cause of this is the assignee's sale of Wood, Bicknell & Potter, and the removal sale of the Tilden-Thurber Co. The demand for these

goods has also been considerably accelerated by the number of June weddings.

Among the manufacturers a majority are at sea as what to prepare for the coming season. Manufacturers of the above lines, however, are moving, but not driving, and all are waiting patiently for developments. With the approach of the athletic season those concerns who make badges and other souvenirs suitable for prizes are receiving occasional orders. The manufacturers of cheap goods are anxiously watching the current of political events in order to be the first on the market with campaign trinkets immediately upon the announcement of the favored candidates. As a whole there is nothing to complain of at the present time.

#### General Dulness in the City of Brotherly Love.

PHILADELPHIA, Pa., June 13.—The approach of July has been attended by a decided falling off in every department of the jewelry business not even excepting the sale of belts, blouse sets and various other articles usually in great demand at this season of the year. There has been, it is true, some extensive selling at spasmodic intervals, but this trade was not sufficient to counteract the frequent periods of dulness; so that June, so far, has been an unfavorable month for the trade generally. The activity exhibited at times was due mainly to special events of importance. There were a number of important matrimonial events, and in connection with these several thousand presents changed hands. The commencement exercises at various educational institutions had a stimulating effect on the sale of a class of goods appropriate for the occasions, and between the brides and the graduates there was a brief period of trade activity. Beyond this there were few calls for valuable goods.

#### Silverware and Cut Glass Moving in Indianapolis, Ind.

INDIANAPOLIS, Ind., June 13.—There has been a good sale of silverware and cut glass for the June weddings. The retail dealers have trouble to meet the constant demand for novelties; especially is this demand hard to satisfy when a customer calls for something new and something that the jeweler will promise will not be repeated in design. The jeweler is fast becoming a slave to the "fad" craze.

#### Carbon Harder than Diamond.

**M.** MOISSON is reported to have discovered a substance harder than the diamond in the form of a compound of carbon and boron, produced by heating boracic acid and carbon in an electric furnace at a temperature of 5,000°. This compound is black and not unlike graphite in appearance, and it appears likely to supersede diamonds for boring rock, cutting glass, and other industrial purposes. It will even cut diamonds without difficulty, and it can be produced in pieces of any required size.—*Nature*.

# The Raines Law

DOES NOT PROHIBIT  
THE USE OF THIS

## Lemonade Stirrer

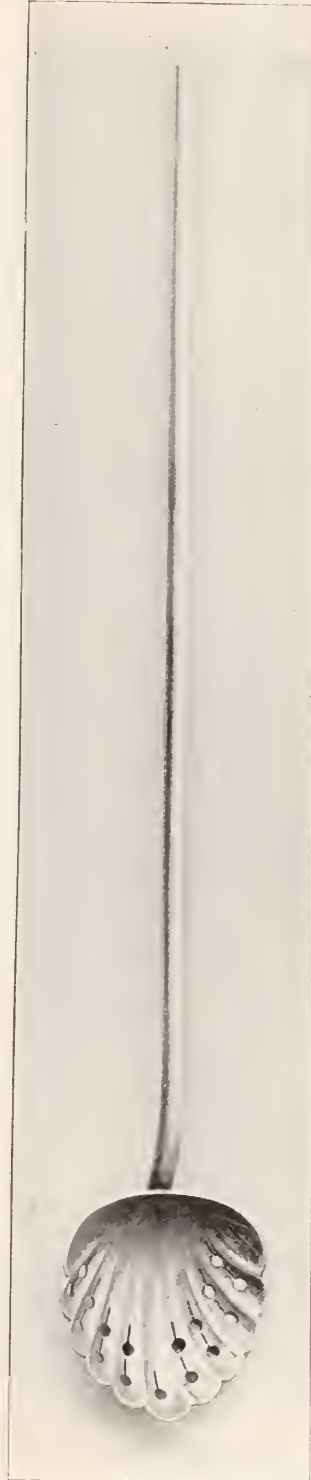

YOU  
CAN  
STIR  
YOUR  
DRINK  
WITH  
THIS  
SPOON  
AND  
USE  
THE  
HOLLOW  
HANDLE  
FOR A  
STRAW.

ORDER  
SOME  
AT  
ONCE  
AND  
STIR  
YOUR  
OWN  
DRINK,  
OR  
ORDER  
AND  
STIR  
YOUR  
TRADE.

STERLING,  
GOLD  
BOWL,  
USEFUL  
PRACTICAL  
AND  
SELLS  
AT  
SIGHT.  
PRICE  
RIGHT.

SEND ORDERS TO

**J.B. & S.M. Knowles Co.,**

SILVERSMITHS,

PROVIDENCE, R. I.

**Summer Fashions in Jewelry and Silver.**

A LADY'S RAMBLES AMONG THE JEWELERS.

Empire fans lead the fashion, and when quite up-to-date, dangle at the end of a long gold chain.

Butterflies with their wings unfolded or closed, flashing now the crimson of the carbuncle, now the rich purple of the amethyst, or the brightness of the emerald, are among favorite models in brooches.

Included in the opulent traveler's outfit is a bill book which holds letters of credit, and made of elephant's hide with gold mounts.

The fashion for ladies' sleeve links gives enterprising jewelers scope for many new designs.

Silver candlesticks are quite the rage, and those in Colonial pattern continue to please.

Chocolate sets of Coalport china afford a pleasing wedding present, and one popular this season.

Belts of white kid, jeweled with turquoise, give instance of the expense lavished on this accessory to Summer dress.

Lilliputian bicycle clocks of silver are now



**Sterling Silver:**

- 1 Inch, - \$12.00 per doz.
- 1 1/4 " - 13.50 "
- 1 1/2 " 15.00 "

and upwards.

- Silver Plate, - - \$24.00
  - Gold Plate, - - )
  - Black and Oxidized, ) per gross,
- assorted sizes.

**DEITSCH BROS.,**  
MAKERS,  
7 East 17th Street,  
NEW YORK.

numbered with gifts presented to women who ride the wheel.

Stationery cases of tortoise shell are mounted in silver.

Fan chains of gold, with pearls at intervals, are made a little heavier than are the lorgnette chains.

For flowers there are quaint shaped vases in cut glass, with colored glass feet.

An English fashion likely to become popular here among lady cyclists is that of the cycle bracelet. This is a curb chain affair in the middle of which is a whistle so set that the wearer is enabled to use it without detaching the chain from the wrist.

Many of the toys of sterling silver which find their way to bric-à-brac cabinets in the house beautiful, are very quaint. The stork is a favorite subject with the Dutch designers. Some designs represent miniature Queen Anne tea sets.

There are some unique knick-knacks in tortoise shell which are charming as gifts, such as little receptacles for stamps, puff boxes, paper knives and the like.

June wedding presents include everything from a cut-glass claret jug to a magnificent chest of silver.

A novel necklace consists of graduated flexible links, thickly incrusting with diamonds, and made to clasp closely around the throat.

ELSIE BEE.

J. A. Musch, Mellette, S. Dak., has sold real estate valued at \$500.

S. Schroeder, Centralia, Mo., has given a chattel mortgage for \$272.

Frank E. Fearl, Hutchinson, Kan., has given a chattel mortgage on his jewelry stock for \$200.

**The Annual Meeting of the Ohio Retail Jewelers' Association.**

PIQUA, O., June 11.—The jewelers who are here to attend the fourteenth annual convention of the Ohio branch of the National Retail Jewelers' association were: C. B. Bargman, of Toledo; Louis F. E. Hummel, Henry B. Rohs, H. H. Mithoefer, Cincinnati; E. G. Lohmeyer, Newport, Ky., and F. Pieper, Covington, Ky. Although the attendance was unusually small this fact did not detract in the least from a profitable discussion of affairs connected with the trade as well as social features attendant.

The first meeting, which was a short one, was held shortly before noon Tuesday, and immediately afterward the attending members were dined at the Plaza. Another meeting took place that afternoon.

**New Bedford, Mass.**

Louis E. Shurtleff has purchased Nathaniel Hathaway's sloop yacht *Addie*.

J. H. Glover, recently of Fall River, has entered the employ of Henry B. Howland, as a watch and jewelry repairer. Mr. Howland's repairing force now numbers four men.

William F. Nye, the Pairpoint Mfg. Co., and the Morse Twist Drill Corporation have received World's Fair medals and diplomas given in token of the superiority of their exhibits at the Columbian exposition.

Frank M. Jenkins has opened an optical and repairing establishment of his own on Purchase St. Mr. Jenkins was formerly with C. W. Haskins, this city, but afterward removed from the city for several years. About a year ago he returned, and has since been with Geo. S. Kelley.

**WOMAN'S CONSIDERATION FOR WOMAN.**

"Mamma," asked the little girl, pointing at the woman on the other side of the car, "what makes the lady wear her rings outside her glove?"

"Hush," said the mother in an aggravated stage whisper. "Don't be rude. The lady wears her rings outside her glove to keep them from blackening her fingers."—*Indianapolis Journal*.

**E. KIRSTEIN'S SONS CO.,**  
MANUFACTURERS OF  
**Optical Specialties,**  
ROCHESTER, N. Y.  
NEW CATALOGUE NEARLY READY.  
SEND US YOUR BUSINESS CARD.

### Proceedings of the Jewelers' Security Alliance.

The regular monthly meeting of the executive committee of the Jewelers' Security Alliance was held at the Alliance office, June 12th. There were present: J. B. Bowden, president; Bernard Karsch, treasurer; H. H. Butts, chairman; and Messrs. Abbott, Wood, and Ball, and Geo. H. Hodenpyl, secretary.

The following firms were admitted to membership: Abelson & Liberman, 113 and 115 Genesee St., Utica, New York; H. Healy, 331 Myrtle Ave., Brooklyn, N. Y.; Clarence F. Pierce, 189 Broadway, New York; David B. Pickering, 65 Nassau St., New York; Louis E. Reinsch, 399 Main St., Buffalo, N. Y.; John E. Shepard, 170 Broadway, New York.

### Prominent Jewelers as Officers of the Review Club of Chicago.

CHICAGO, Ill., June 13.—About 100 members attended the annual meeting at Kinsley's of the Review Club, the organization which during the past year has perpetuated the good features in the work of its predecessor, the Sunset Club, and has improved on them.

The election of officers for the ensuing year resulted as follows: President, G. J. Corey, manager, Pairpoint Mfg. Co.; 1st vice-president, J. P. Byrne, of Lyon & Healy; 2d vice-president, General John McNulta; 3d vice-president, A. H. Revell, head of A. H. Revell & Co.; treasurer, G. A. Jewett; secretary, J. C. Moore.

The organization is composed of men of all business callings and enlists the best business men of the city. There are now 800 members, including the lunch auxiliary with a membership of some 265, who daily lunch together in the club's quarters on the third floor at Kinsley's, known as the "Pink Room."

### The Carborundum Company Doing a Large Business.

PITTSBURGH, Pa., June 13.—The stockholders of the Carborundum Company, at a meeting in Monongahela City, June 9, voted to increase the capital stock from \$100,000 to \$200,000. The company have lately bought an important Canadian patent, and find customers for 25 per cent. of their product in the Dominion. The plant at Niagara Falls is in full operation, and the company's condition is very satisfactory.

### Capt. James W. Cusack Retires from Business Life.

TROY, N. Y., June 11.—Captain James W. Cusack sold to-day his long established business to Charles B. Alexander and E. B. Williamson, who will continue the business at the same store in the *Times* building. Mr. Alexander has been associated as a clerk with Captain Cusack for about nine years. Mr. Williamson has been connected with the Ludlow Valve Co. for a number of years.

Captain Cusack will retire from active mercantile pursuits. He has conducted a jewelry store in Troy for about 45 years, and has become one of the most reliable jewelers in this

part of the State. His store in the *Times* building has been considered among the first jewelry establishments in this vicinity. His retirement is taken with a view to resting after a long business career. The new firm will be Alexander & Williamson.

### Pittsburgh.

F. McBurney, traveler for Heeren Bros. & Co., is on the sick list.

Leo G. Weil will shortly travel for a well known eastern house.

E. J. Bubb, this city, struck a 100-barrel well last week at Wildwood.

Herman Cerf, of the firm of M. Bonn & Co., has returned from an eastern trip.

Walter Powell, Cumberland, Md., is running an auction, and will remodel his store.

J. Mazer, formerly with M. Mazer, Allegheny, is now with C. C. Corcoran, Wood St.

C. E. Yelgerhouse, the Erie, Pa., optician, was in the city last week for the Saengerfest.

On Saturday last, the rooms of A. E. Siviter, Verner building, were entered and robbed of \$50 worth of material.

A. M. Andrews and Philip Bauman, of Heeren Bros. & Co., have gone to Atlantic City and Cambridge, respectively.

F. A. Robinson, Clarksburg, W. Va., passed through the city last week with his family en route home after a lengthy southern trip.

C. J. Duncan, Canal Fulton, O., was in the city last week, and bought a large invoice of goods, preparatory to starting a new store at Canal Fulton.

Mrs. Rachel Susman, widow of Louis Susman, the Wylie Ave. jeweler, who died some three months ago, died at 9 o'clock, May 31 at the family home, 13 Wylie Ave., aged 70 years.

Heeren Bros. & Co. made 25,000 medals for the Saengerfest. These were of brass, gold plated, and found a ready sale among the host of visitors. The manufacturing department of the firm is working double time.

Among the jewelers who visited the city last week, and "did" the Saengerfest were: Leo Furtwangler, Greensburg, Pa.; H. Reineman, McKeesport, Pa.; A. Teplitz, McKeesport, Pa.; James Bruce, Burgettstown, Pa.; Charles Lohman, McKee's Rocks, Pa.; E. Kaiser, Brownsville, Pa.; F. A. Heberlein, New Brighton, Pa.; H. Wubbeler, Beaver Falls, Pa.; Frank Worrell, Washington, Pa.; A. A. Poole, Washington, Pa.; J. R. Grieb, Butler, Pa.

The jewelry firm of Boukofsky, Washington St., Oakland, Cal., has been attached on a judgment in favor of D. A. Currin, San Francisco, in the sum of \$2,000.

Hasso R. Pestalozzi, Milwaukee, Wis., has made a voluntary assignment to Lawrence Murphy. The bond of \$5,000 was signed by John A. Holt and James I. Jones as sureties.

James Davidson, jeweler, who was once a resident of Hamilton, Ont., but who had been in Montreal for some years, is fitting up a handsome store on the corner of King and Mary Sts., Hamilton, and will open up business in a few days.

## SOMETHING NEW.

# Lemonade Spoons.

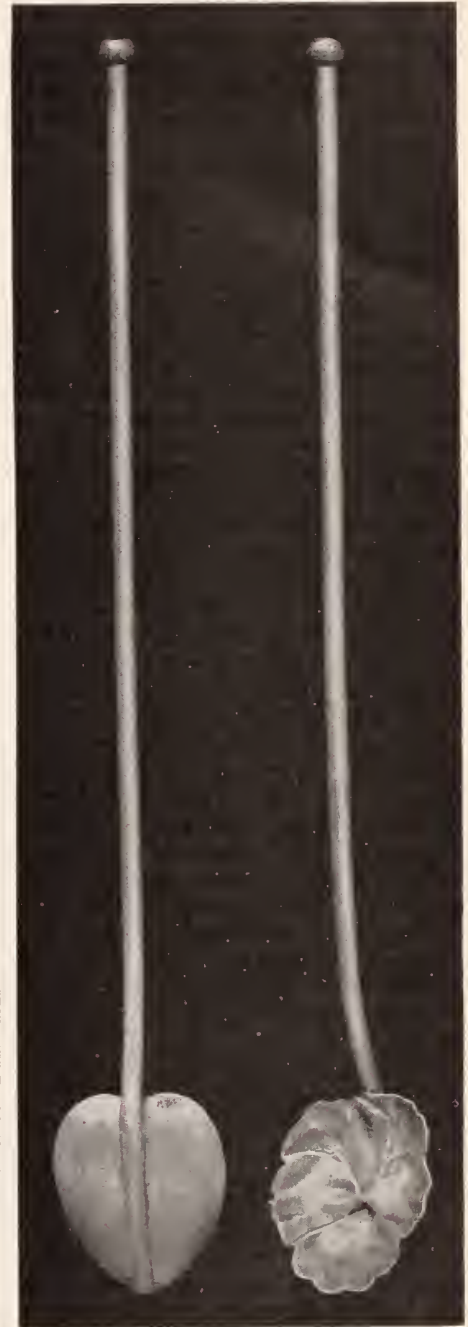

5463 GOLD BOWLS. 5462

The handles are hollow and can be used instead of a straw, and easily cleaned.

STERLING SILVER

925-1000 FINE.

MANUFACTURED BY

## Barstow & Williams,

28 Fountain St., Providence, R. I.

Something New every week in the Year.

## THE GENESIS AND ARTISTIC DEVELOPMENT OF THE LOVING CUP.

Copyright, 1896, by THE JEWELERS' CIRCULAR PUB. CO.

## PART I.

THE newspapers have almost daily during the past year reported the presentations of loving cups to noted persons, societies, clubs and winners in races and competitions. The loving cup has come to be a reward of merit for special effort and special good work. It has proven to be the solution of the controversial problem, as to what is the most appropriate thing to demonstrate one's practical appreciation of another's qualities or efforts. This difficulty has been especially prominent when the recipient for the mark of recognition is a public person. The past banqueting season was particularly remarkable for the number of loving cups given to honored guests. This practice of donating a loving cup has been found to fill all requirements. The honored person is the recipient of a work of art of enduring qualities and intrinsic value, and one that represents the sentiments of love, good-will and fellowship. For this use of the loving cup, the silversmiths are called upon to tax their fullest knowledge of their art to produce works possessing elaborate and ornate, yet harmonious and consistent effects. Large sums of money are spent on these productions, cups valued at \$1,000 being quite common. However, the popularity of the loving cup does not stop here. Not only are first-class silversmiths making them by the score, but silver-plated ware makers, glass makers, and potters are producing them by the hundreds. Loving cups are not only made in sterling silver, but in English art pottery, electro silver-plate, rich cut glass, American pottery, Bohemian glass, and German and French pottery, which indicates that the article is of wide-spread popularity and is demanded in many avenues of life.

Societies organized for all purposes now have their loving cups and bestow them upon those they honor, the ceremonious rite of the presentation and use of the cup having become a prodigious fad. Not only has the loving cup become the recognized emblem of victory in the yacht race, golf game, rowing match, foot ball match, curling match and every variety of sport and contest, but it is the *ne plus ultra* of wedding gifts, no bride being thoroughly content with her lot unless she receives one. Also it appears that there is to be inaugurated in this country the old English custom of presenting a fitch of bacon and a loving cup to couples who have been married a year, and who during that period have never quarreled nor spoken a cross word to each other.

This custom, the common story goes, originated in Essex County, England, about 500 years ago, when a wealthy nobleman bequeathed a sum of money, the interest of which was to be used for buying the cups. The winning couple are selected by a jury of six bachelors and six spinsters. The suc-

cessful competitors must swear that during their 12 months of married life no harsh words have been spoken and no quarrels have occurred. Frederick Barr, Westchester, N. Y., has given funds for a trial of the plan in this country, and the first presentation will be made July 16 at a fête at Sherman Park. A committee, composed of William Launder, Frederick Barr and Henry Klaus, of Westchester, Charles Smith, of Unionville, Charles F. Van Orden, of Yonkers, C. L. Breece and Samuel Prescott, have been making the arrangements, and the young married folks of Westchester are making entries for the contest. We suspect Mr. Barr's scheme has something to do with the sale of lots at Sherman Park; however, his scheme may result in increasing the already wide-spread popularity of the loving cup.

To trace the genesis\* of any article of domestic use, whose nomenclature has changed with the passing centuries, is an extremely difficult if not impossible task. What we to-day call the loving cup is of ancient origin, though the term is of modern birth, so modern in fact, that it is only in works treating of present day customs that it is employed, and then only sparingly. All that the Century Dictionary has to say on the subject is: "Parting cup—a drinking cup having two handles on opposite sides, as distinguished from Loving Cup, which usually has more." This definition is all right as far as it goes and will support the assertions of those who claim that a two-handled cup is really a stirrup cup and not a loving cup, though at the present day both may be used for similar purposes. However, as every utensil in the domestic economy has passed through modifications in the cycling of the centuries, perhaps there is no truer method for arriving at the origination of any given article than to trace its uses to the very beginning. The twig with a cavity dug into it, used by prehistoric man to carry liquid in small quantities to his mouth, was as much a spoon as the present King's pattern. Reversely, every article resembling in outward form the convention loving cup of to-day, is not a loving cup or even a stirrup or parting cup; for unearthed cinerary urns, whose environment convince archaeologists were products of the iron, bronze or even stone periods, have remarkably similar shapes to many of the prize two-handled loving cups that are the pride of clubs to-day; while if the multiplicity of handles was to govern the employment of terms we would call a four-handled cinerary urn, which has

been dug from the grave of some long-forgotten contemporary of the bronze period, a loving cup, which is not reasonable. Of course it may be argued that these urns were used as drinking vessels during the lives of them whose bone ashes they contained when unearthed. But such arguments would be only speculative and they would rest upon no foundation in fact. It is only known that the urns were used for burial purposes; there is evidence of nothing else. Every thing that has been used by man to hold liquids of sufficient quantities to quench thirst, to form part of a ceremony, or to satisfy the desire for imbibing some variety drink, is a cup; and it is for us to subdivide the forms and customs of drinking to determine the origination of any variety of drinking utensil; in other words we must trace customs, and, if in the course of our delvings we should come across the custom and the shape of the article employed agreeing with those of to-day, our labor will be all the more interesting. But before we enter upon our task, we will quote the little treating of the loving cup distinctly as such that appears in authoritative works.

In an extended series of articles by John W. Miles, entitled "The Cup—Its Art and Customs," which appeared in THE JEWELERS' CIRCULAR in its issues of 1883 and 1884, the author refers to "a beautiful wassail horn at Queen's College, Oxford, presented by Queen Philippa. It is now used as a loving cup. The horn is Buffalo and surrounded with three silver gilt bands with the word 'waceyl' engraved three times upon each. Connected with the two lower bands are bird's-claw feet, upon which it rests. The small end terminates in a monster's head. This can be removed and the horn sounded, and, as according to the statutes, the students were to be summoned by the sound of a horn, this horn may have been used for that purpose as well as for drinking. The celebrated Cawdor horn is much more elaborate, having a foot of silver upon which rests the horn between the royal supporters. It is said to have been the first drinking vessel used by Henry, Earl of Richmond, after landing in England in 1485, and presented by him to David up Evan, son of Roderick the Great, who lived at Llwyndafydd in Llandisiliogogo, and there entertained the Earl and his men in his expedition against Richard III." This quotation Mr. Miles gives from Cripp's "Old English Plate."

Continuing Mr. Miles writes: "The introduction of Christianity did not alter the custom of wassailing, but rather gave it a religious aspect. The wassail bowl or cup became a part of the table furniture in the great monasteries, and received the name of *poculan caritatis*, which may be freely translated a grace cup or loving cup. Or if used exclusively for secular purposes it often has re-

\*The word genesis, in its broad definition, was used in the title of a paper, "The Genesis and History of the Cup," prepared by Charles E. Buckley, of the Whiting Mfg. Co. The word appeared to us to be fraught with meaning, and it is with Mr. Buckley's permission that THE JEWELERS' CIRCULAR uses it in the copyrighted title of this article.



ligious inscriptions or mottoes. A very popular kind of drinking vessel of the olden time of 'Merrie England' was the Mazer bowl. They were made of wood, usually maple, and mounted at the rim in gold or silver. The larger bowls, holding half a gallon or more, were on feet. Handsomely polished they

cups made for a long time, and they are of every size and degree of finish. The two loving cups, the property of Harvard University, are good examples. That with the gadrooned base and cover has the well-known London maker's mark, 1 C, mullet below, lobed shield. It is engraved with a coat of arms and the inscription:

The Gift  
of the  
Hon. William Stoughton  
Who died at  
Dorchester  
July 7th  
1701.

"Among the numerous pieces of plate of which this maker's mark is to be found are the plain tankards ex dono Sebright, at Jesus College, Oxford (1685). The plainer loving cup has also a coat of arms, and the inscription:

From  
the Bequest of  
Col. Samuel Brown,  
of  
Salem,  
1731.

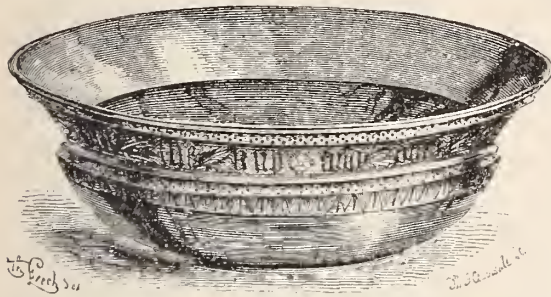

MAZER (TEMP. RICHARD II.)  
From "Old English Plate."

formed a very beautiful cup, and the metal work was often richly chased, while engraved on the bottom St. Christopher appeared before the eyes of the wassailer as he finished the bowl. The one figured bears the legend,

"In the name of Trinitie  
Fille the kup and drmk to Me."

We quote the part regarding the Mazer, because we will have more to say regarding it later on. We have quoted from Mr. Miles' admirable work all that appears to us to relate to the loving cup, as this article is commonly understood to be; we will call upon him again for data to support the broader interpretation of the term. J. H. Buck in his "Old Plate" refers to the loving cup as follows:

"The maker, John Burt, was a Boston goldsmith; his name is to be found on the large flagon presented to the New North Church in 1745, now in possession of King's Chapel."

In Cripp's standard work "Old English Plate" the only specific mention of either the loving cup or the wassail bowl or cup we find is that quoted by Mr. Miles and printed above; while John Hungerford Pollen's "Gold and Silver," a notable book on the gold and silversmith's work in the South Kensington Museum, has only the following to say on the subject: "The wassail bowl was round like the Mazers, passed from hand to hand and was the favorite drinking vessel. It was sometimes covered with costly work; enameled with the arms of the owner, or had curious emblems and choice old legends expressive of hearty good-will and fellowship, inscribed on the rim and cover. St. Christopher engraved on the bottom appeared before the eyes of the wassailer as he drained the bowl."

In "An Illustrated Descriptive Catalogue of the Collection of Antique Silver Plate formed by Lord Londesborough," written by Frederick W. Fairholt, F. S. A., and "printed for private reference" in 1860, appears the following paragraph: "In addition to the continental trade guilds, there were also companies of cross-bowmen and arquebusiers, who met to practice shooting, and who had their banqueting halls well furnished with silver plate. The



LOVING CUP (1731) HARVARD UNIVERSITY.  
From "Old Plate."

"This brings us to the XVIII. century and the simple but massive two-handled cups, with covers, that marks the reigns of Queen Anne and the earlier part of the Georgian period. These seem to have been the only

finest cups in Lord Londesborough's collection originally did duty at Gorichern, in Holland, for such a society, and specimens of others once appertaining to guilds are also in the collection; and the cut on next page

represents one of the largest in the series, which appears, from an inscription upon it, to have belonged to a German company of clothes workers, and also further informs us

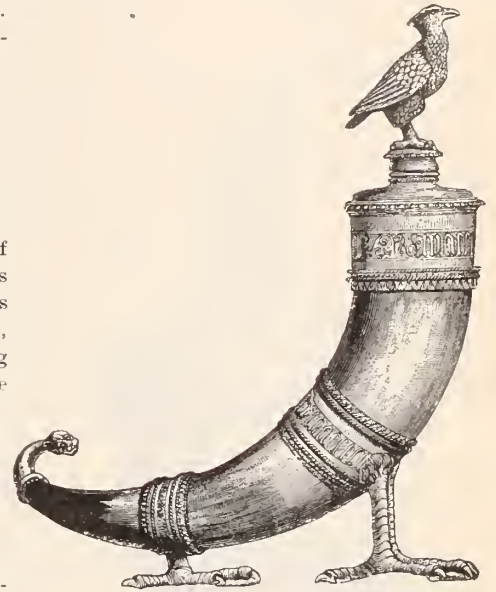

WASSAIL HORN (14TH CENTURY), AT QUEEN'S COLLEGE, OXFORD.

From "Old English Plate."

that it was the work of a certain goldsmith named Michael Klaemet, in the year 1647. It is formed of silver, and is nearly three feet in height; it is hung all round with small silver shields, containing the arms, badges, or 'merchant-marks' of various members of the fraternity, who were probably thus commemorated for benediction to the company, when these 'loving cups' passed round the table on public occasions. The dates on these escutcheons range between the years 1653 and 1693." This paragraph with the cups it refers to opens a broad field for treat-

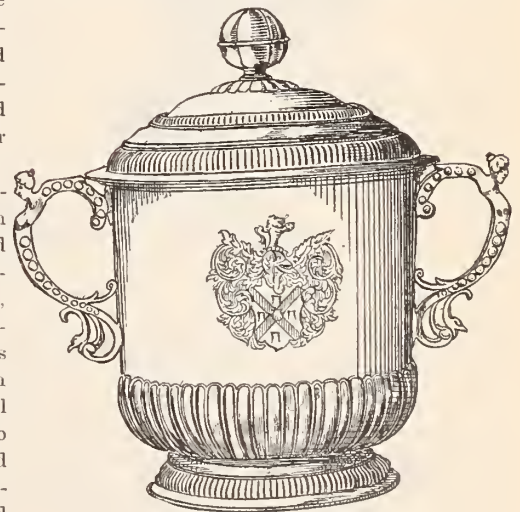

LOVING CUP (1700) HARVARD UNIVERSITY.  
From "Old Plate."

ment of the loving cup in its mediæval forms; but before continuing this portion in the history of the development of the loving cup, we will trace as far back in time the custom consisting of groups of persons drinking out

of the same large vessel, which is the essential purpose of the loving cup, whatever be its



LOVING CUP (1647) GERMAN  
COMPANY OF CLOTHES WORKERS.

shape or the material used in its construction.  
(To be continued)

#### Official Statement of the Affairs of the United States Watch Co.

WALTHAM, MASS., June 12.—In the course of the settlement of the estate of the late Emil C. Hammer, treasurer and almost sole owner of the United States Watch Co., it was necessary to go through the form of dissolving the corporation. Thorvald F. Hammer, a brother of the late E. C. Hammer, is now the owner of the property. At present the factory is being run profitably on the regular 6, 16 and 18 size movements and there is no intention of making a cheaper line of goods as was recently stated in a trade sheet. The work of the fac-

tory on the regular lines will be continued as before.

The above statements are official and are from T. F. Hammer direct.

#### Death of Judge H. Sidney Hayden, a One-time Jeweler.

HARTFORD, Conn., June 10.—The funeral services of Judge H. Sidney Hayden, of Windsor, for many years a noted jeweler, took place to-day, at his residence and later at Grace Church, Windsor, where the remains were viewed by a great number of people.

Mr. Hayden was born in Windsor, the eighth of a family of eleven children. Nathaniel, the oldest son, spent the early part of his life in Charleston, S. C., in the establishment known as the Hayden Store, dealing in jewelry and military goods. He retired to private life in 1842, but becoming interested in the Chatham National Bank of New York he was elected president of that institution, which office he held 15 years, the stock increasing 100 per cent. in value during that time. He was one of the first bank presidents to urge the policy of supplying the government with money needed to maintain its supremacy.

Judge Hayden's boyhood days were spent in Windsor. At the age of 16 he entered the country store then conducted in Windsor by the Loomises. After spending three years there he went to Charleston, S. C., and joined his brother in the Hayden Store, then the finest store of the kind in the country. He became deeply interested in the success of the business and in 1843 became the head of the firm, on his brother's retirement.

#### Newwitter & Rosenheim's Offer of 20 Cents in Composition Refused.

PROVIDENCE, R. I., June 11.—A meeting representing a large percentage of the creditors of Newwitter & Rosenheim, New York, was held at the rooms of the Manufacturing Jewelers' Board of Trade, Tuesday. The official statement of the firm's condition as presented by the receiver, Philip Rosenheim, is as follows: Total liabilities, \$82,822.47, including \$13,513.47 for borrowed money and salaries. These latter claims have been secured by a transfer of open accounts amounting to \$17,157.23; leaving an indebtedness of \$3,000 due the Mechanics and Trades Bank, and \$66,309 due for merchandise, neither of which is secured. The total assets amount to \$24,534.08, which include book accounts which, at face value, amount to \$19,222.72, and in which are the accounts above referred to as transferred to secure claims of salaries and borrowed money, and stock on hand estimated at \$5,011.36.

The receiver made an offer of 20 per cent. payable in well secured notes, but this was declined, and the creditors stated that an offer in cash of not less than 25 per cent. of the respective claims would receive consideration, although no definite action was taken to accept an offer of 25 per cent. The receiver

also gave notice that the stock had been advertised to be sold at private sale and that bids for the same would be received until June 18, the receiver reserving the right to reject any or all bids.

#### Aftermath of the Terrible St. Louis Cyclone.

St. LOUIS, Mo., June 13.—Clarence White, of the J. Bolland Jewelry Co., said to THE CIRCULAR correspondent: "Two days after the tornado a gentleman called in the store and bought a bill of goods. I had never seen him before; in fact he said he was a non-resident and asked for some information in regard to the 'cyclone district.' I directed him, and in the afternoon he came back, and asked if I would receive a contribution for the fund for the sufferers. I assented and he drew out a cheque for \$100, signed it F. W. Bles, and gave it to me. I do not know where he came from, and he did not seem to care to be ostentatious about what he was doing, and evidently was influenced by the scriptural injunction not to let his left hand know what his right hand did."

J. Bolland, of the J. Bolland Jewelry Co., had losses on property by the cyclone amounting to fully \$1,000, F. W. Drosten had a loss of \$300, and Geo. R. Stumpf, \$300.

At the meeting of the board of directors of the Missouri Retail Jewelers' Association, held June 10, a committee was appointed consisting of Geo. R. Stumpf, chairman, and Herman Mauch and Arnold Zerweck, associate members, to look after all jewelers and members of kindred trades who had suffered by the cyclone. THE CIRCULAR man called upon the committee and found them very busy; they have already afforded relief to five different people.

Mr. Chambers whose store was so badly wrecked in the cyclone, mention of which was made in THE CIRCULAR, was seriously injured as well. He was taken to the City Hospital, but as soon as he was able to be moved he was taken to Benton, one of the suburbs of St. Louis.

Gerhard Eckhardt has moved to his new location, 6th near Olive St.

A. J. Carter, of Sloan & Co., New York, remitted \$10 on the 13th inst, to A. L. Steinmeyer, to be placed to the credit of the fund that has been raised for the tornado sufferers.

#### POETRY AND BUSINESS.

One of the principal objects of poetry is to produce a sensation of pleasure. When a stanza of poetry contains an order for goods, as in the verses below, the sensation of pleasure is enhanced a hundredfold.

"With the gentle breath of Summer,  
Comes a postal from the hummer,  
Saying, send a diamond ring, size eight.  
Ten dollars is to be the price,  
Have it clear, white and nice,  
And in every way right up-to-date.  
You can make your own selection,  
For I've found without exception,  
Your judgment on diamond rings is great."

This poem was received by B. L. Strasburger & Co., 17 Maiden Lane, New York.

### Keck Released till the Final Disposition of the Case by the Supreme Court.

PHILADELPHIA, Pa., June 13.—When Herman Keck, of Cincinnati, O., was sentenced by Judge Butler in the United States District Court on June 9, he was taken by a Government official to the Eastern Penitentiary to serve the sentence of one year. His counsel, A. S. L. Shields, and some western attorneys lost no time in carrying the case to the United States Supreme Court, and were granted the necessary writ of error by Justice Shiras upon which to secure their client's release, pending final disposition of the matter by the higher tribunal.

Accordingly Clerk Lincoln, of the United States District Court here, went to the Penitentiary yesterday and surprised Keck by presenting the papers calling for the release of the convicted man. Bail has been entered in the sum of \$10,000 for Keck's appearance when wanted. The Equitable Trust Co. are now his surety.

### An Unusual Method of Paying His Wages.

POMEROY, O. June 10.—Chas. C. Beach, for a year a salesman in Hart & Co.'s jewelry store was arrested on the charge of grand larceny, and bound over to court in the sum of \$200. Beach is charged with taking \$150 worth of goods from the store in which he was employed, to satisfy a claim of that amount which he had against the firm for labor. The case embodies some peculiar com-

plications. Mr. Beach, who has borne a good reputation while in this city, has been in the habit, as he claims, of taking whatever wages might be due him from time to time from the stock and charging it to himself on the books. This he claims to have done with the knowledge and consent of Mr. Hart. Recently he gave notice that he intended to resign his position Saturday evening. The firm owed him over \$150 salary and on Friday he selected that amount of goods from the stock at wholesale prices, in the presence of two witnesses, and charged himself with the same on the books, adding 6 per cent. as profit to the firm.

Mr. Hart, who had been absent at Gallipolis for some time, returned Saturday and made a row about the matter, finally having a warrant issued for the arrest of Mr. Beach. Beach claims to have acted on the advice of an attorney in the matter, and supposed he was doing perfectly right.

The following former students have returned to the Parsons' Horological Institute, Peoria, Ill., to complete their course: Allen Lee, Centralia, Kan.; J. O. Rome, Rome, Tex.; D. C. Vanderhoef, Lodia, O., and C. A. Chenwooth, Richmond, Ind. New students who arrived during this month to the 12th inst., were: M. J. Abbott, Forrest Grove, Ore.; A. C. Holland, Lapeer, Mich.; E. A. Bultman, Sumter, S. C.; G. W. Ellis, Butler, Mo.; Joe Mantz, Peoria, Ill.; Walter Little, Cumberland, Md., and Albert and Milton Danner, Tuskegee, Ala.

### Trans-Atlantic Voyagers.

TO EUROPE.

Henry F. Cook, of the Fahys Watch Case Co., New York, accompanied by his wife, sailed for Europe Thursday, on the *Normania*. On the same steamer were: B. H. Davis, of B. H. Davis & Co., New York, and Henry J. Lingg, New York.

Capt. R. E. Burdick, of the Bowler & Burdick Co., Cleveland, O.; C. H. Dorflinger, of C. Dorflinger & Sons, New York; A. W. Maddock, of Maddock & Co., New York, were passengers on the *Paris*, which sailed for Europe June 13th.

Thos. Le Boutillier, of Le Boutillier & Co., New York, was a passenger on the *Etruria*, which sailed for Europe June 13th.

Leon Barre, of Tiffany & Co., New York; J. Wertheimer, New York, and M. A. Benziger, of Benziger Bros., New York, sailed for Europe June 13th, on *La Touraine*.

FROM EUROPE.

A. Ludeke and Maurice L. Powers, of Powers & Mayer, New York, arrived from Europe last week on the *Teutonic*.

Thomas Benfield, Newark, N. J., arrived on the *New York*.

Simon Frankel, of Jos. Frankel's Sons, New York, is due from Europe June 19th, on the *Fuerst Bismarck*.

Murray M. Henry, jeweler, McKeesport, Pa., has presented the members of No. 3 fire station with an elegant eight-day clock.



## A Prize Winner

IN COMPETITION WITH  
114 DIFFERENT WHEELS.

In the voting contest inaugurated by THE NEW YORK EVENING TELEGRAM, to determine which Bicycles were the

most popular with the Bicycle riders,

## THE "REGENT" TOOK 3RD PRIZE,

having received an enormous number of votes, in such company as the oldest wheels; Columbia, Rambler, Victor, Humber, &c. This contest, in which many thousands of ballots were cast, clearly showed which bicycles **BEST SATISFIED THE RIDERS**. The "Regent" has been on the market but a short time and its record in achieving **SUCH GREAT POPULARITY IN SO SHORT A TIME STANDS UNPRECEDENTED**.

SEND FOR CATALOGUE AND TERMS TO

**THE UNITED STATES CYCLE CO.,**

30 MAIDEN LANE, NEW YORK.

SELL THE

**"REGENT"**

AND SATISFY

YOUR CUSTOMERS.

## PULSE OF THE JOBBING TRADE ON THE PROPOSED ASSOCIATION.

### Expressions of Opinion from the Principal Jobbing Centers.

#### NEW YORK JOBBERS ABOUT EQUALLY DIVIDED ON THE SUBJECT.

From a canvas of the New York watch jobbing trade made by a CIRCULAR reporter Monday it would appear that the chances are against the formation of an association of watch jobbers on the basis embodied in the plan recently drawn by Elihu Root which was published in full in THE CIRCULAR last week; at least such is the case if the opinions of the New York jobbers be any criterion of the feeling of the entire trade. Among those opposed to an association based on Mr. Root's plan are some of the largest jobbers in the trade such as Henry Ginnel & Co., C. G. Alford & Co., Hayden W. Wheeler & Co., Keller, Ettinger & Fink, Oppenheimer Bros. & Veith, and S. F. Myers & Co.

Many opponents of organization under this plan, however, expressed themselves as not against any movement that would tend to stop the cutting of prices. Others were opposed to organization under any plan. James H. Noyes, who has been calling upon the jobbers in the west, returned Monday. He told a CIRCULAR reporter that there was no doubt that a convention of jobbers would be called for about the middle of July, to be held in New York city. The sentiment outside of New York, he said, was almost universally in favor of a convention, though the trade was not committed to any plan for organization.

In speaking of the reception of Mr. Root's plan by the trade in the west, Mr. Noyes said that considering the time they had had to examine it, he thought their expressions of opinion were reasonably favorable.

Among the houses seen by a CIRCULAR reporter were the following:

Weis & Oppenheimer—Had not given the matter much thought, but did not think they would go in any association.

David Keller, Keller, Ettinger & Fink—Would not join. The plan was all right as far as it went and so was the old association, but he believed no organization of jobbers would be effective or do any good.

Mr. Brainerd, Middleton & Brainerd Co.—Had not been approached, but would not join as he never yet knew of a combination that was not broken or made to be broken by a favored few.

H. H. Butts, of Hayden W. Wheeler & Co.—Did not favor the organization on general principles and would not join.

C. G. Alford & Co.—At this office THE CIRCULAR reporter was informed that the firm were opposed to the movement.

Oppenheimer Bros. & Veith—While not against organization, they did not believe in the plan proposed.

Adolph Goldsmith, of A. Goldsmith & Son—Had signed the agreement and was in favor of

the association, but did not think it would go through as the plan embodied some features which were objectionable to manufacturers and others and were opposed by the jobbers.

Avery & Brown—Did not care to express an opinion.

F. R. Simmons, Henry Ginnel & Co.—Opposed the movement because it put a premium on dishonesty and could not be effective.

R. L. & M. Friedlander—Had signed and believed the plan effective, and that a combination is necessary, as there is no money in the watch business without it.

Sweet & Ellsworth—Had not given the subject any consideration, and had not yet determined whether they favored the plan or not.

J. T. Scott & Co.—Were in favor of any plan or movement that would prove effective in stopping ruinous competition.

S. F. Myers & Co.—Would not join, as they believed an organization on the basis proposed would be unjust and illegal.

J. W. Sherwood opposed the plan as the honest man would not benefit by it. The need of the trade was a demand for goods, and the association could not create this demand.

The opinions of E. S. Smith, of Smith & Knapp, and N. H. White, of N. H. White & Co., in favor of the association have already been published.

Koch, Dreyfus & Co. will support any plan adopted by the trade and join the association if the majority of the large houses give it their support.

Adolphe Schwob—Against the plan, if it is as published in THE CIRCULAR last week, as he believes it ineffective. He is not against organization.

Aikin-Lambert Jewelry Co.—Favor this or any other method that will stop the present evils resulting from the cutting of prices, and are favorably impressed with Mr. Root's plan.

#### THE CHICAGO JOBBING TRADE EAGER TO SEE AN ASSOCIATION FORMED.

CHICAGO, Ill., June 13.—A meeting of Chicago jobbers of American watches was held in the Columbus building Tuesday, the 9th inst., to consider the plans for a new association of watch jobbers as framed by Elihu Root, of New York. The discussion was of a purely informal nature and was in thorough accord with the views understood to be held by the New York jobbers, at whose suggestion the meeting was called. Mr. Noyes, of New York, outlined the matters that might be brought before a meeting of jobbers if a National convention could be brought about. The Chicago jobbers expressed themselves as willing, in fact desirous, of meeting the jobbers of American watches in other cities in convention for the purpose of talking over the state of the watch trade, and to devise ways and means of placing

the trade on a more satisfactory basis. There was a practical unanimity of opinion that a National convention and full discussion would result in the betterment of trade in the way of correction of certain evils that have gradually crept in.

It was regarded as a necessity that manufacturers should aid in attaining these desirable results, but it seems probable that if the jobbers can agree there will be no obstacles placed in their way by the manufacturers.

The following resolution was adopted:

CHICAGO, June 9th, 1896.

At a meeting of the jobbers in American watches held this afternoon, Mr. M. A. Mead was called to the chair and the following resolution was submitted.

Mr. Otto Young moved, seconded by Lem. W. Flershem and resolved that we are in favor of meeting in convention the jobbers of American watches in the United States for the purpose of considering the state of the watch business and whether there may not be some method adopted to put upon a more satisfactory basis.

Otto Young & Co., Lapp & Flershem, Benj. Allen & Co., H. F. Hahn & Co., F. C. Happel Co., C. H. Knights & Co., Stein & Ellbogen Co., M. F. Barger & Co., A. Hirsch & Co., M. A. Mead & Co., F. Lewald & Co., B. F. Norris, Alister & Co.

General manager John M. Cutter, of the Elgin National Watch Co., was Friday asked by THE CIRCULAR representative for an opinion on the plan drawn by Elihu Root and published in full in THE CIRCULAR of last week. He replied:

"There are so many interests involved and so many conditions to be changed in order to comply with the articles of agreement between jobbers and manufacturers that it is impossible for any one man now to say whether all that is desired can be accomplished or not. It is too early yet to give an opinion on the subject. If we were the only parties interested it would be a very easy matter to prescribe a cure for many of the existing evils."

#### ST. LOUIS JEWELERS EXPRESS VARIOUS IDEAS ON THE SUBJECT.

ST. LOUIS, Mo., June 12.—J. H. Noyes was in the city this week calling upon the jobbers relative to forming a new association of wholesale dealers in watches. THE CIRCULAR correspondent interviewed the following dealers in regard to the proposition, and while none of them spoke of Mr. Noyes' visit they gave their ideas in regard to such action.

Meyer Bauman, of L. Bauman Jewelry Co.: "I am in favor of a jobbers' association that would be for the social benefit of the members thereof. And it might also apply itself to any particular grievances that might come up from time to time. But I am not in favor of an association that would be organized for any particular manufacturer or manufacturers."

Edwin Massa, of the Bauman-Massa Jewelry Co.: "I am in favor of such an organization if it is practicable, but even if it was formed I do not believe under the proposed plan it would be carried out. Anything of this kind to be effectual must of necessity originate with the manufacturers."

M. Eisenstadt, of the M. Eisenstadt Jewelry

Co.: "From what I can understand there is one manufacturer of watch cases and movements who will not co-operate. In that event it will be simply useless to advocate an association for the reason that it will be impossible with that factory on the outside to control either the product or regulate the price. Even should all manufacturers co-operate, under the present conditions of trade it would be impossible for the jobbers forming the association to use the entire production, thus creating dissatisfaction among the manufacturers, who would be unable to place their product among the members of the association, and compel them to find an outlet for their product in other channels. My experience with associations has been that they start out to do what is right, but they eventually result in the gain and profit of a few to the detriment of the majority of the members. We are opposed to an association of any kind. An improved condition of trade will solve the problem and maintain prices, better than any association."

J. H. Rivers, of the Providence Jewelry Co.: "We have sold goods at list prices right along and shall continue to do so, association or no association."

S. A. Rider, of the S. A. Rider Jewelry Co.: "I am very favorably inclined towards an association of this character, because I think it would give the legitimate jobber a chance to make a profit. The larger jobbers had not kept faith with the old association, and the smaller ones had to follow in their footsteps. I can't see why any class of men should do business for nothing."

#### THE BOSTON JOBBING TRADE DIVIDED IN ITS ENDORSEMENT.

BOSTON, Mass., June 13.—The Boston jobbers are not what might be termed enthusiastic over the project of forming a new association of jobbers in American watches, and two prominent houses declined to sign the call for the convention.

President Charles F. Morrill, of the Boston Jewelers' Club, speaking for the Morrill Bros. Co. and the E. A. Whitney Co., said to-day that both these corporations had signified their approval of the association idea, and he hoped to see a strong organization effected, one that should unite all interests and be productive of stability in the matter of prices.

David C. Percival, Sr., of D. C. Percival & Co. says: "If an association can be formed that can be made effective, I am in for it. The last one worked well enough at the start, but toward the latter part of its career it became demoralized. I hope this one when it is formed will be a permanent success."

M. N. Smith, of Smith, Patterson & Co., said that this firm did not sign the call. "We don't believe it will produce the results the promoters hope to have it accomplish," he added, "judging by previous attempts and their outcome, not only in the watch jobbing line, but in associations among the silverware men, other branches of trade, and combinations generally."

Some of the other jobbers, while admitting that they signed the call for the convention, had no decided opinion to express for or against the project. Most of them would favor it, however, if they could be assured that the association membership would adhere to its original purpose and maintain a strong combination to hold prices firmly.

Harwood Bros. take the same ground that Smith, Patterson & Co. do in the matter. C. F. Morrill said that when the convention meets the Morrill Bros. Co. will probably send a representative to the gathering.

#### LOUISVILLE JOBBERS HEARTILY IN FAVOR OF THE MOVEMENT.

LOUISVILLE, Ky., June 13.—The Louisville jewelers are taking great interest in the movement to organize a watch jobbers' association such as was outlined in THE CIRCULAR, June 10th. The jobbers are, of course, the ones most concerned. George H. Kettman & Co. said to a representative of THE CIRCULAR that they were heartily in favor of the movement. Mr. Lorch, of the Lorch Jewelry Co., said he had just read what THE CIRCULAR had to say in regard to the jobbers' association, and that he thought such an organization would be very beneficial to the trade. He thinks, however, it will be difficult to establish the association in Louisville.

#### PHILADELPHIA JOBBERS THINK SUCH AN ASSOCIATION ADVANTAGEOUS.

PHILADELPHIA, Pa., June 13.—The June 10 issue of THE JEWELERS' CIRCULAR containing detailed plan for the formation of a watch jobbers' association, attracted considerable interest. The article was read with care and the prevailing opinion seemed to be that some such movement would be advantageous to the trade. Of late, business has been so quiet that an apathetic feeling now exists among the tradesmen and it is doubtful indeed if any combined action on their part could be secured at this particular season. Some of the principal jobbers are inclined to believe, however, that with vigorous pushing, the promoters of the enterprise will be enabled to gain a substantial foothold in this city during the Fall months.

#### THE TRADE OF CINCINNATI WANT A MORE CENTRAL MEETING PLACE.

CINCINNATI, O., June 13th.—J. H. Noyes, ex-secretary of the old National Association of Jobbers in American Watches, was in Cincinnati to-day interviewing the jobbers with a view of resurrecting the old association, or rather of organizing a new one for the protection of prices, etc.

He stated that a meeting would be held in New York, July 13th, invitations to attend which will be sent out to the jobbing trade everywhere for representation, and he hoped a full attendance would be the result. Some of the trade ask: Why did not the promoter of this scheme make the place of meeting more central? No doubt many would like to attend, but the expense of a trip to New York from the western points is quite an item.

#### PITTSBURGH DEALERS GENERALLY ENDORSE THE MOVEMENT.

PITTSBURGH, Pa., June 13.—Circular letters from Mr. Noyes regarding the formation of the new watch jobbers' association have been received by the jobbers of this city, and while it is too early to give definite opinions as to the beneficial results to be derived from joining the association, the general idea prevailing is that the movement is a good thing. Among those who have signified their intention of joining are: G. B. Barrett & Co., Goddard, Hill & Co., Heeren Bros. & Co., and M. Bonn & Co.

West, White & Hartman can see as yet no material benefit to be derived by them, as they handle but one line of watches. This firm unite in saying the organization is a needful one for those dealing in different lines. The watch trade has during the past two weeks assumed a more cheerful aspect, and dealers are pleased with the outlook.

#### SYRACUSE JEWELERS FAVOR THE IDEA OF AN ASSOCIATION, BUT DOUBT ITS FEASIBILITY.

SYRACUSE, N. Y., June 13.—The general opinion among Syracuse jobbers seems to be that the proposed watch jobbers' association is a good idea if such an organization could be maintained. With the prevailing dull times, however, dealers are so anxious to sell that nearly every one cuts prices, and few could be depended upon to stand by the agreement published at length in last week's CIRCULAR. There is a prevailing idea that the scheme would not go through.

The following are copies of the letters sent by the committee to the manufacturers and jobbers:

(Letter to Manufacturers.)

NEW YORK, May 28th, 1896.

Gentlemen: Inclosed please find a copy of the plan for a new organization of jobbers of American watches, which has been drawn up by Hon. Elihu Root, at the request of a number of jobbers who were sufficiently interested in the matter to guarantee the necessary expense of securing his services. Mr. Root has had a very extensive experience in matters of this kind, and believes that the organization which he has arranged would prove practical and effective in securing the objects desired, while at the same time he has been careful to make it free from all legal objections, as it contains nothing that is contrary to either the national laws or those of any of the States.

At a meeting of interested jobbers, the general principles laid down were approved, and the undersigned were appointed a committee to further the movement, and bring it to the notice of the jobbers in other sections of the country, with a view of calling a convention to consider the subject and perfect the details, if a sufficient number of the jobbers are in favor of doing so to make it advisable.

In the mean time this copy is sent for your information, and the plan is commended to your favorable consideration.

Yours truly,

A. V. HUYLER, }  
E. S. SMITH, } Committee.

(Letter to Jobbers)

For several months a number of the New York jobbers have been talking together about the demoralized state of the American watch business, and trying to find some way to bring about a better condition of affairs. They disliked to move in the matter without consulting with the jobbers in other sections of the country, but as it seemed to be absolutely

necessary to have some general principles laid down for consideration, before anything could be done, they finally decided to engage Hon. Elihu Root to draw up a plan for a new organization of jobbers, requesting him to confine it to the main points involved, leaving all details to be settled by a convention of jobbers, in case one should be called as a result of their action. Mr. Root has had a very extensive experience in matters of this kind, and believes that the plan which he has outlined would prove to be practical in operation and effective in securing the objects desired, while at the same time he has been very careful to keep it entirely free from anything which would be contrary to either the national laws or those of any of the States.

At a meeting of the jobbers interested, the general idea advanced by Mr. Root was approved, and the undersigned were appointed a committee to further the movement.

This copy is sent for your information, and we have requested Mr. Noyes to call upon you regarding it, as he has assisted Mr. Root, and is therefore better acquainted with all the points than any one else, and able to explain the plan.

He will be in your city in a few days, and if you are in favor of having a convention called to consider the subject, he will be glad to hear your views as to the best time and place for holding it. Yours truly,

A. V. HUYLER,  
E. S. SMITH,  
Committee.

A reporter of THE CIRCULAR approached on the subject some lawyers well known in the trade, among them Edmund T. Oldham, of Wilbur & Oldham, attorneys for the Dueber Watch Case Mfg. Co., who furnished his views in the form of the following communication:

NEW YORK, June 13, 1896.

Editor of THE JEWELERS' CIRCULAR:

I cannot think of any reason for drawing a new contract for a watch jobbers' association except a belief, in the minds of the jobbers, that there is something the matter with the old. If I have hit upon the true reason for framing the new plan, I do not hesitate to say that the jobbers are greatly mistaken.

As between the new and old plan, the old one is better at all events in so far as it expressly covers many more of the details.

If there is an impression that the success of the Dueber action, as far as it went (that is to say, the decision of all the courts on demurrer that the Dueber Company had a good cause of action against the defendants), was due to any defect or illegal thing contained in the agreement of Feb. 8th, 1887, it is a great mistake.

Nothing on the face of the Feb. 8, 1887 agreement was illegal, but it contained a provision that the By-laws might be added to or subtracted from, and that a committee of six should act in conformity with those By-laws.

Now, is there anything in that Feb. 8 agreement which provides for the remarkable circulars that were sent out by Mr. Noyes?

Is there anything in that agreement of Feb. 8, 1887, which provides for the things that were done to Mr. Mansfield?

Is there anything in that agreement of Feb. 8, 1887, which provides for a thousand and one things that the Big Six, so called, actu-

ally did in its desperate attempts to hold the Association together?

No.

But it was for these things that Dueber brought his action. It was the doing of these things that Dueber proved upon the trial. And it was whether or not the doing of these things (not mentioned in the Feb. 8th, 1887 agreement, not provided for in that agreement even if you read between the lines), was the sole reason for the loss of Dueber's business that was submitted to the jury. They could not agree.

The Feb. 8th agreement cannot be improved until one is made which will give all parties a right to go into Court with an unblushing front and demand its enforcement.

What's the use of making agreements providing for a penalty that if a man breaks his agreement he shall have his ears cut off, if, when the knife is upraised, the Court will say stop. Surely, if the members know that this will be the result of any attempt to enforce any punitive provisions of the agreement, they will do as they please.

It has occurred to me frequently that if the manufacturers should publish a price list in which they announce that as an inducement to the trade they would hereafter sell exclusively to jobbers, and that to all purchasers of over one million dollars' worth of goods per annum a discount of such and such per cent. would be allowed and to none others; to take advantage of such an offer and which, if jobbers were thereby induced to purchase, would constitute a CONTRACT, it would be necessary to do such a business as that no single jobbing house could avail themselves of it.

Consequently a number of them could employ some person not possessing means enough to act independently, and furthermore of sterling honesty, as their exclusive buyer for a year at a commission which would be a fraction of a per cent. of the discount, and it seems to me that with very little difficulty this same operation might be repeated as between the jobbers and retailers.

Of course this is only a suggestion. It would need the assistance of someone thoroughly familiar with the business to co-elaborate with Mr. Root. Mind you, I don't say this is in any sense a plan. There may be very serious obstacles, perhaps technical difficulties, in the way. My sole idea is to work upon a plan which is to be, above all things else, a contract, for I am convinced that until such a contract is framed no plan will ever succeed.

It has really never been decided whether the old plan, in so far as it is contained in the agreement of Feb. 8th, 1887, could have been enforced or not, but I am reasonably sure that this new plan could not be enforced, if only because it does not contain any words of obligation.

"To agree to officially recommend." "The offices of the jobbers' association to be used to publish offers by manufacturers of special facilities, etc."

Surely such expressions as these mean nothing in law.

If the publication in your issue of this week is a true copy and a full and complete copy, I have no hesitancy whatever in expressing my belief that the new plan is *nudum pactum*.

EDMUND T. OLDHAM.

#### The Death of Charles Field Haviland.

PARIS, June 12.—Charles Field Haviland died this morning at Chateau Masmarrant, his country home near St. Victornien, after an illness of two years.

Chas. Field Haviland, one of the best known manufacturers of Limoges china in the world, was born in North Castle, Westchester county, N. Y., Aug. 1, 1832. His ancestors settled in Westchester county as early as 1711. Soon after the birth of his son, the elder Haviland moved from his old home to Brooklyn, where his son attended the public schools. After finishing the course there he entered Haverford College. He left Haverford in 1851 for France to enter the French pottery business in the employ of Haviland & Co., in Limoges. He began his work on January 1, 1852, and later in the same year he married Mlle. Louise Mallevergne, a granddaughter of Francois Alluaud, who was one of the oldest manufacturers in Limoges, having founded the Alluaud manufactory in 1797.

In 1859 Mr. Haviland left the employ of Haviland & Co. to start in business for himself, in conjunction with his uncle, Richard F. Haviland, of New York. The line taken up by this firm was the decoration of pottery, using chiefly that which was manufactured at the Alluaud manufactory. This work he continued for about nine years, and in 1868 he became a manufacturer of French porcelain at Vierzon and Limoges. In 1876 he assumed control of the Alluaud factory at Limoges, and continued in the management of it until his retirement from business in 1881. In 1870 Mr. Haviland, in connection with Oliver A. Gager, also formed the firm of Charles Field Haviland & Co., doing business at 49 Barclay St. In 1881, upon his retirement from business, Mr. Haviland sold his interest in the New York house to his partner, who continued the business under his own name. The present name of the firm is Haviland & Abbot, 29 Barclay St., the head of the firm being a younger brother of the founder. In Limoges, Mr. Haviland's successors at the Alluaud factory were E. Gérard, Dufraissieux & Co. Mr. Haviland was a special partner in this firm until the time of his death. Mr. Haviland will be buried in the family burial ground near the chateau in which he died. He leaves a widow, one son and one daughter. The son is a manufacturer of brandy at Jarnac.

Powers & Mayer, diamond importers, 208 Fifth Ave., New York, announce from their London house, 105 Hatton Garden, that Maurice L. Powers has personally selected an extensive stock of fine diamonds, pearls, and fancy precious stones; and has secured the very latest and richest artistic diamond mounting designs to be found in the leading cities of the continent.

# The Jewelers' Circular

AND  
HOROLOGICAL REVIEW.

PUBLISHED EVERY WEDNESDAY BY

THE JEWELERS' CIRCULAR PUB'G CO.,

189 BROADWAY, NEW YORK CITY.

A JOURNAL DEVOTED TO THE INTERESTS OF JEWELERS, WATCHMAKERS, SILVERSMITHS, ELECTRO-PLATE MANUFACTURERS, AND ALL ENGAGED IN KINDRED BRANCHES OF INDUSTRY.

Member of the American Trade Press Association.

Our Editorial columns will contain our own opinions only, and we shall present in other columns only what we consider of interest or value to our readers. Advertising matter will not be printed as news.

Advertising rates in THE CIRCULAR are lower, considering the number of tradesmen reached by its large circulation, than in any other jewelry journal.

Notices of changes in standing advertisements must be received one week in advance; new matter can be received up to Monday.

## INFORMATION FOR SUBSCRIBERS.

### Terms of Subscription, Postage Prepaid.

United States and Canada, . . . . .	PER ANNUM.	\$2.00
Foreign Countries in Postal Union, . . . . .		4.00
Single Copies, . . . . .		.10

New Subscribers can commence at any time.

Payments for THE CIRCULAR when sent by mail, should be made in a Post-Office Money Order, Bank Check or Draft, or an Express Money Order or Registered Letter. All postmasters are required to register letters whenever requested to do so.

Pay money only to authorized collectors having proper credentials.

**Returning Copies:** Returning your paper will not enable us to discontinue it, as we cannot find your name on our books unless your address is given.

**Changing Address.** In changing address always give the old as well as the new one. Your name cannot be found on our books unless this is done.

**Discontinuances.** We will continue to send papers until there is a specific order to stop, in connection with which all arrearages must be paid; but such an order can be given at any time, to take effect at or after the expiration of the subscription. All such orders will be promptly acknowledged by mail.

**Liability.** The Courts have decided that all subscribers to Journals are responsible until arrearages are paid in full and an order to discontinue has been received by the publisher.

## THE JEWELERS' CIRCULAR IN EUROPE.

Among the Places in Europe where THE JEWELERS' CIRCULAR is on file are the following:

**LONDON**—First Ave. Hotel, Holborn, E. C.; Holborn Viaduct Hotel, Royal Hotel.

**PARIS**—Hotel de L'Athénée, Rue Scribe.

**BERLIN**—Deutsche Uhrmacher Zeitung, Jager-Strasse, 73.

**GENEVA**—Journal Suisse D'Horlogerie.

**AMSTERDAM**—Continental Club, Hotel Amstel.

**ANTWERP**—Diamond Club, Rue de Pelican.

Vol. XXXII. June 17, 1896. No. 20.

Every line of reading matter in THE JEWELERS' CIRCULAR, with the exception of the few brief extracts from exchanges, always properly credited, is written exclusively for this journal. Each issue of THE JEWELERS' CIRCULAR is copyrighted. Permission to quote is extended to other publications if such quotations are properly credited.

### The Proposed Watch Jobbers' Association.

THAT the making and the dealing of watches have, during the past two to three years, been profitless enterprises has been the common knowledge of all manufacturers and all jobbers and retailers of these timepieces. Among the causes that have led to this condition of affairs have been the universal depression in business, and the turning of a large portion of the spending capital of the people from its erstwhile customary channels into a new and special channel, the bicycle. However, these causes are of a transient nature; but during the period of their existence a third circumstance has arisen to which the profitlessness of the watch business is mainly due, and which will produce most disastrous results to the industry at large unless radical changes are soon effected. This cause of the demoralization of the watch business is the ruinous and unlimited cutting of prices. Only fools and old women quote senseless aphorisms to serve as arguments. Whenever some plan is suggested to stem the tide of ruinous competition, an opponent voice is sure to be heard saying that competition is the life of trade. Instead of being the life, competition, as we see it to-day, is the degradation and death of trade. When through the merciless cutting of prices, and the consequent diminution and final disappearance of profits, it becomes necessary to so reduce the wages and curtail the hours of labor of thousands of factory work people, that they can be said to live only because they do not die, or it becomes necessary to throw out of work entirely thousands of work people, any plan that will obviate this condition of affairs must be considered good and beneficent.

The plan prepared by Elihu Root to serve as the basis for a watch jobbers' association, published in last week's issue of THE CIRCULAR, has aroused much discussion and some opposition in the trade; but from the dispatches and interviews of our correspondents located in the great jobbing centers, printed on pages 16, 17 and 18, of this issue, it will be seen that a large number of jobbers favor the plan, while the jobbing trade are almost unanimous in desiring that some system be adopted to stop the present price slashing practices. It is to be hoped that a system be soon adopted; but let this system, plan, association or agreement take the form of a mutual contract, non-compliance with which by any member will be a subject for court interference. Lawyers have told us that such a contract can be made drawn, which will not collide with either the National anti-trust laws or any State anti-trust laws. If an organization can be formed, whose members will sign such a contract, the watch business may return to its old time condition of prosperity. The retailers, whose interests THE CIRCULAR has first in mind, will ultimately be the greatest gainers, for the stability of the market will keep the watch business in its legitimate channels, and these dealers will be able to reap a living profit in their business, which is the very reasonable desire of every merchant.

### The Threatened Invasion of Japan.

THE House Ways and Means Committee, which during the recent session of Congress devoted much time to the question of the menace to manufacturers by the threatened invasion of the cheap products of Oriental, especially Japanese labor, on June 9, made an interesting report, which throws considerable light on the subject. After reviewing the causes that have placed Japan in the commercial arena, the report says that the sudden awakening of Japan from the Oriental slumber of centuries is being followed by an equally rapid westernizing of her methods of industry. The Japanese do not have the inventive faculty of Americans, or even of Europeans, but their imitative faculties are wonderful. Their standard of living would be regarded as practical starvation by the workmen of the United States, and hours of labor average 12 a day. Skilled workmen as blacksmiths, carpenters, masons, compositors, tailors, and plasterers receive in Japanese cities only from 26 to 33 cents, and factory operatives 5 to 20 cents per day in our money. The report has the following to say in respect to the Osaka Watch Co.'s factory regarding which some details, as authoritative as have been possible to obtain, have already been published in THE CIRCULAR:

"Recently a watch factory, with American machinery, was established by Americans, although the stock is held in the names of Japanese, as foreigners will not be permitted to carry on manufacturing in their own names until 1899, and the progress made indicates that the enterprise will prove a success." The wonderful imitative qualities of the Japanese are well evidenced in this connection alone. The company were organized on Nov. 15, 1895, and the factory has been running only since last January; yet the 12 American experts who were engaged to teach the Japanese workmen in the various processes that enter into the production of a watch have some time since been dispensed with, with perhaps the single exception of P. H. Wheeler, the superintendent, who, according to last reports, was still with the company. As to the wages of the operatives in this factory, Mr. Wheeler, in an article in this Journal, Feb. 26, 1896, wrote: "They receive on an average only 18 cents per day, silver." The report further says:

"While your committee have not found that any articles of importance made by factory methods in Japan, outside of cheap silks, handkerchiefs, matings, rugs, etc., have as yet invaded the markets of the United States, most of the articles as yet imported from Japan being hand-made or household woven goods, yet it is probable that the rapid introduction of machinery into Japan will, within a few years, make Japanese factory products, especially fine cottons, silks, and other articles in which the labor cost here is an important element in production, a more serious competitor in our markets than the products of Great Britain, France and Germany have been, simply for the reason that Japanese wages are lower than European wages, and

Japanese labor likely soon to become as effective with machinery as European labor is. This result will be counteracted somewhat by the inevitable tendency of contact with civilization to improve the standard of living, and consequently the wages of the Japanese workmen."

The Japanese competition will differ, not in kind, but in degree, from European competition, and the committee knows no remedy outside of absolute prohibition against convict labor goods, or the imposition of duties on competing goods equivalent to the difference of cost and distribution. Notwithstanding there is at present no apparent lack of expedients to check the threatened competition, if this competition gives signs of assuming the proportions that are feared, the most drastic legislation should be adopted to crush it, even if a special exclusion law is necessary. The productions of modernized Japan are not like those of other countries, namely the fruition of decades of inventive development, but are the last and full expressions of other nations' genius, produced by human parrots. However, if the observations of one of the American watchmaking experts since returned to America have any weight, the American watch manufacturers have as yet little to fear from competition with the Japanese. "The Japs are fine imitators, but they are not worth much as mechanics. They are not exact enough and do not appreciate the value of care in their work. They do not have and do not seem able to develop that fine mechanical discrimination so characteristic of the good workman. They simply imitate and they pick up what they do get with wonderful rapidity, but they do not get all the fine points. Still they have made a remarkable beginning, and their acquirement of the finer points in watchmaking as well as in the other mechanical arts, is only a matter of time, and perhaps a short time at that."

#### THE CIRCULAR REPORT OF THE N. E. M. J. ASSOCIATION OUTING PREEMINENT.

PROVIDENCE, R. I., June 10th, 1896.

Editor of THE JEWELERS' CIRCULAR:

I have your issue of June 10th. I wish to congratulate your reporter on the neat way in which he eclipsed all local reporters in reports of the occasion.

Yours truly,

WARREN S. LOCKE.

R. I. School of Design.

When the result of the ballots in the New York Evening Telegram's bicycle contest was announced last Wednesday, it showed that the "Regent" bicycle had received the third greatest number of votes. It was in popularity behind only the "Columbia" and "Rambler" and ahead of 114 other makes. The "Regent" bicycle is sold by R. L. & M. Friedlander, 30 Maiden Lane, New York, who feel justly proud of the position in public esteem their wheel has been shown to occupy. These wheels, by the way, are used by the New York Post Office employes.

#### New York Notes.

Jules Racine & Co. have entered a judgment for \$253.79 against Gallo Bros. & Volpe.

A judgment for \$300.76 against Benj. S. Wise has been entered by Jules Racine & Co.

T. B. Starr has satisfied the judgment for \$4,301.78 entered by Chas. Picketslay, July 17, 1893.

The Mechanics' and Traders' Bank has entered a judgment for \$3,047.59 against Newwiter & Rosenheim.

The judgment for \$158.38, entered by Tiffany & Co., Oct. 15, 1891, against Chas. S. Develin, has been satisfied.

Adolph Goldsmith & Son, 68 Nassau St., have been elected to membership in the New York Jewelers' Board of Trade.

The store of Benedict Bros., Cortlandt St. and Broadway, was closed Monday, owing to the death of Mary Evelyn, daughter of Reed Benedict, which occurred Friday, from heart failure.

Anna Fairchild, the only daughter of Leroy W. Fairchild and sister of Leroy C. Fairchild, of Leroy W. Fairchild & Co., died at Orange, N. J., Saturday. The funeral services will be held at noon to-day at St. Stephen's Church, 57 W. 46th St.

Jacques Spiegel was appointed Saturday receiver in supplementary proceedings for Frank Pollatschek, of 223 E. 71st St., by Judge Andrews, of the Supreme Court, on the application of Max Pollatschek, and the bond was fixed at \$10,000. Pollatschek was an instalment dealer in jewelry at 191 Broadway, and failed a few months ago.

Chas. Lahey, a 16-year-old boy, of Williamsburg, was remanded in the Ewen St. Police Court on the charge of forgery. Harris Woronov, a jeweler, 727 Grand St., Brooklyn, swore that on June 6 Lahey attempted to purchase a watch with a check for \$40, which contained a forged indorsement of the payee's name. Lahey said he found the check and endorsed it himself.

The Alvin Mfg. Co. have finished the beautiful prize cup presented by the Brooklyn Eagle as a trophy for miniature yacht races. It is a two-handled loving cup, 10 inches high, and has on one side a large and perfectly modeled eagle with outspread wings, while upon the reverse is etched an illustration of a toy yacht and the inscription "Brooklyn Eagle Perpetual Challenge Trophy for Model Yachts."

The Sheriff, Monday, received an attachment against S. Harris, jeweler at 382 Grand St., for \$930 in favor of Julia Dietz which was obtained on the ground that he had disposed of his property. Herman J. Dietz said that he called at the store on June 8, when he saw there a stock of diamonds and jewelry worth \$20,000, but when he called again Saturday all the stock had disappeared, except \$2,000 or \$3,000 worth. The Sheriff was informed that Mr. Harris had given a bill of sale of the stock to an auctioneer for \$1,900. Herman J. Dietz, who made the affidavit, was formerly a diamond dealer at 68 Nassau St. and failed about a year ago in a similar manner to Harris but for a larger sum.

Daniel H. Stites, at one time a wholesale jeweler at 57 Maiden Lane, was held in \$1,000 bail by Justice Tighe, in the Butler St. Court, Brooklyn, Thursday morning on a charge of perjury. His daughter-in-law, Mrs. Alice Stites, the complainant, says that when Stites was examined in supplementary proceedings on Dec. 2, 1895, he swore falsely that he had not owned any stock in any corporation except the Stites Jewelry Company, for five years prior to the date of the examination. Mrs. Stites says that he did own stock in the Journeay & Burnham Company, Brooklyn, and the Hall-Marvin Safe Company, New York. Stites was arrested on the same charge several months ago, but the Grand Jury failed to indict.

On July 18, 1895, Samuel Dimond's store, 23 Riverdale Ave., Yonkers, was reported to have been robbed of nearly \$1,000 worth of diamond rings, gold watches, chains, trinkets. The theft was in the afternoon, and no one knew how it was done. The police doubted the story of Dimond, and not until eight months after did they gain any information about the robbery. A woman named Marinceo recently notified the authorities that her little brother Joseph had been the robber, and said she saw her mother extract a number of diamond rings, watches and some money from a flower pot and afterward pawned them in New York. The mother, Mary Marinceo, who is 55 years old, and the boy who is 13, were both arrested. Mrs. Marinceo was tried last week in the County Court at White Plains, on the charge of receiving stolen goods, and was convicted and sentenced Thursday to two years in Auburn Prison. The boy has been sent to the House of Refuge.

Free entry was granted last week for the Burden jewelry recovered in London, with the provision that when the seals on the package are broken a Customs officer shall be present to see that it contains only the articles inventoried when the extradition papers were granted for the thieves who stole the jewels. Special Deputy Collector, Jos. J. Couch, in speaking of the question which has arisen over the Burden jewels as to whether or not they should pay duty, said to a CIRCULAR reporter, Monday, that the goods were still under seal and in the hands of the District Attorney of New York, to be used only as evidence against the thieves. The question of duty had not been settled and the authorities were still waiting an opinion from the Treasury Department. All diamonds, he explained, whether stolen or not, are primarily dutiable and even though an exception be made in cases of involuntary exportation and return, the identification must be so thorough as to preclude the possibility of fraud, before the goods will be admitted free. He did not think the conviction of the thief or thieves was absolutely necessary to obtain their surrender from the Custom House.

The Long Island City Star of June 11th, contained a complimentary note about J. Feinberg, jeweler, 56 Vernon Ave., that city, and called attention to the additions he had recently made to his store.



## Special Notices.

Rates 75c. per insertion for notices not exceeding 3 lines (25 words); additional words 2 cents each. If answers are to be forwarded, postage stamps must be enclosed. Two insertions, 15 per cent. off; three insertions, 20 per cent. off; four insertions or more, 25 per cent. off. Payable strictly in advance. Display cards on this page will be charged at \$2.00 per inch for first insertion, subject to same discount as above for subsequent insertions.

Under the heading of **Situations Wanted** on this page advertisements will be inserted for **One Cent a Word** each insertion, no discount. This offer refers to **Situations Wanted only**. Payable strictly in advance. If answers are to be forwarded, postage must be enclosed.

## Situations Wanted.

Notices under this heading **ONLY** are charged at one cent a word, payable strictly in advance. If answer are to be forwarded, postage must be enclosed.

**FOREMAN.**—By first-class jeweler and silver novelty maker, position as foreman. Best references. Address C. A. S., care JEWELERS' CIRCULAR.

**WATCHMAKER** would like position with a reliable house; 15 years' experience on fine and complicated work; full set of tools. Address Elgin, care JEWELERS' CIRCULAR.

**A DESIGNER** familiar with the best class of work in sterling silver is open for immediate engagement, or would give part of his time. Address H. A. G., care JEWELERS' CIRCULAR.

**YOUNG MAN**, 8 years' experience as watchmaker and salesman; also bicycle repairing and selling; age 25; single; best references; own tools. W. H. Hettesheimer, Washington C. H., Ohio.

**WANTED AT ONCE**, position by first class watchmaker and engraver; good jewelry repairer; own tools; salary, \$15 per week; best references furnished. Address H. C. Morey, 215 Newcastle St., Brunswick, Ga.

**POSITION** by young man 24 years of age, several years' experience in jewelry business; salesman and general repairer; open until Sept. 15th; sober and practical; best of references. Address W. B. W., care JEWELERS' CIRCULAR.

**WANTED**—An opportunity to represent reputable manufacturers on the Pacific coast by an experienced traveling salesman, thoroughly acquainted with the better class of trade on the coast. Address F., care JEWELERS' CIRCULAR.

**SITUATION WANTED** as a watchmaker's assistant, salesman, etc.; can repair watches, clocks jewelry and engrave coffin plates; is of sober, industrious habits, honest and faithful; A1 references. Address H. M. Stansbury, Pawtucket, R. I.

**I HAVE A YOUNG MAN** in my employ who is worth more than I can afford to pay; I would like to get him a permanent position; he is a good watch and clock maker and jewelry repairer, and good habits. Address Lock Box 894, Lyons, N. Y.

## Help Wanted.

**WANTED.**—Experienced traveling salesman to handle best American line of spectacles through New York State and the East. Address Optics, care JEWELERS' CIRCULAR.

## Business Opportunities.

**FOR SALE**, Brooklyn, N. Y., jewelry store; good location, low rent; inventory about \$1,000; can reduce. For particulars address A 82, care JEWELERS' CIRCULAR.

**\$1,200** will buy my 6,800 lb. steel-lined safe, plate glass store fixtures and balance of my clocks and silverware; will sell watches and jewelry if wanted; best opening in Oklahoma for a live jeweler. Chas. E. Rose, El Reno, Oklahoma.

**FOR SALE** in Philadelphia, a desirable business in a fine locality; clean stock about \$8,000, which can be reduced if desired; walnut fixtures, fine regulator, safes, etc.; good run of work; established 12 years. Address O. E., care JEWELERS' CIRCULAR.

**\$650 00 SPOT CASH** buys fixtures, material and optical goods of leading jewelry and optical store; established 15 years; western New York; bench work \$1,500 per year; only optician; will sell any other part of stock if desired. Address J. O., care JEWELERS' CIRCULAR.

## To Let.

**TO LET**—A good office on the third floor in the Diamond Exchange Building, 14 Maiden Lane, N. Y.; now occupied by the Fletcher Watch and Jewelry Co. This office will be rented very low to May 1, 1897. Apply to Janitor, or Smith & North, 14 Maiden Lane, N. Y.

## For Sale.

**FOR SALE.**—A Marvin fire-proof safe; outside width 54 inches, height 65 inches, depth 28 inches. R. A. Loveland, 177 Broadway, N. Y.

## FOR RENT.

Large Office,  
5th Floor - - **Corbin Building.**

Will let very low for

Three Years.

APPLY, - - - -

**JOSEPH FAHYS & CO.,**

NO. 54 MAIDEN LANE, N. Y.

**SPECIAL** IN **NOTICES**  
IN  
**THE JEWELERS' CIRCULAR**  
Produce the results desired.



It Pours Good Things  
IN  
**THE JEWELERS' CIRCULAR!**

Optical Department, Workshop  
No es, Retail Advertising, Seasonable Fashions, Buyers' Bureau  
Connoisseur.

\$2 per year—4c per week.

**WATCH**

**GOLD FILLED.**



**CASES**

I VIEW A BUSINESS

with the eyes of  
a customer==

write because of this business-bringing advertisements.

I have been an ad-writer all my life—know "how" and "where" to advertise.

As I will handle the advertising for but *one* jeweler in a town, you had better address me *now*. My price is \$5 per week by the year.

For further particulars look up my advertisement in the THE CIRCULAR of June 10th, page 24-d.

ALFRED MEYER,

P. O. Box 2254,

New York.

Send for  
New Catalogue  
of 200 Books

pertaining to the Jewelry, Watchmaking, Assaying, Engraving, Optical and Kindred lines, published or for sale by the Jewelers' Circular Publishing Co. The only complete Catalogue published for these trades.

Sent Free upon Application.

The Jewelers' Circular Pub. Co.,

189 BROADWAY, N. Y.



PRIZE  
MEDALS  
From  
EXCLUSIVE  
DESIGNS,

for out-door  
Sports.  
Club Pins  
of every  
description.

HENRY C. HASKELL.

11 John Street, New York.

Send for estimates.

### Providence.

All communications for this column, addressed to P. O. Box 1093, Providence, R. I., will receive prompt attention.

A. Levy, of Philadelphia, was in town the past week.

S. A. Baldwin started last week for the west in the interests of Baldwin, Ford & Co.

D. M. Watkins & Co. is the style of a new firm of designers, tool makers and die sinkers recently started at 59 Page St.

A majority of the manufacturing jewelers are removing with their families to their Summer homes in the country and by the seashore.

Charles E. Hancock, of Hancock, Becker & Co., will be one of the committee in charge of the Young Men's Christian Association Juniors' Camp at Mount Hope Bay this Summer.

Many of the shops in this vicinity that have been closed for one and two weeks for annual repairs, have started up again. Prospects are reported to be encouraging for a fair business during the Summer and early Fall.

John S. Brandt, who was awarded the three prizes offered by the New England Manufacturing Jewelers' Association, through the Rhode Island School of Design, is the designer for the jewelry concern of Cory & Reynolds.

Secretary M. W. Morton, of the Manufacturing Jewelers' Board of Trade, has been disseminating to the interested members a cash settlement of 20 cents on the dollar to the creditors of E. B. Floyd & Co., Boston, Mass., who failed some months ago.

Several of the manufacturing jewelers of this vicinity will remove the coming Fall into the new Metcalf building, Pine, Richmond and Page Sts., and the new Wilcox building, Washington St., both of which are rapidly nearing completion.

George W. Dover, of Dover & Pritchard, denies the story that has been going the rounds for several days, that this concern has or is about to dissolve. Mr. Dover and family have just returned from a pleasure trip to Pittsburgh, Pa., the home of Mrs. Dover's parents, and a few days ago his partner, George W. Pritchard, started on a pleasure trip to California.

### Philadelphia.

President Sackett, of the Jewelers' Club, has been enjoying the silvery waves at Cape May.

After Sept. 15 there will be five extensive jewelry establishments on Chestnut St., between 9th and 10th Sts.

The first award of a Simon Muhr scholarship has been made, Harold Harrison Tryon securing the coveted prize.

Harry Weinrich, who has been traveling in the west representing J. A. Schwarz & Co., has returned after a successful trip.

Some important amendments to the rules governing the awards of the Simon Muhr scholarships have been made by the executors of the estate and the Board of Education. The amended rules have been submitted to the Board of City Trusts.

In the Orphan's Court Judge Hanna has filed an adjudication of the first account of Judge Mayer Sulzberger, William B. Hackenberg and Fannie Muhr, trustees of the estate of Simon Muhr, who died in February, 1895. The pecuniary legacies have been paid, and the annuities are provided for. The schedule for the distribution of \$91,800, presented by the trustees, was approved. A balance of \$26,180.16 is to be the subject of future accounting.

His shopmates and the officers of the Philadelphia Horological Society, of which he is secretary, tendered a banquet to Chas. Murset, foreman of the watch-repairing department of the Bailey, Banks & Biddle Co., on the evening of the 9th inst., previous to his departure on a trip to places of interest in the Western States and Alaska. His itinerary comprises St. Louis, Yosemite Valley, San Francisco, Sitka, Juneau, returning by way of the city of the Mormons, Pike's Peak, Cripple Creek, Denver, Omaha, and Chicago. He expects to be absent two months.

A clock with a history was recently brought to this city for repairs, by the owner, John Lindsay, of Chester. The time-piece is known as a "grandfather's clock." It was manufactured in England nearly 150 years ago. During the Revolutionary war it was owned by Gen. William Brook, of Haverford township. The British plundered the house

one night, and being short of bullets they stole the heavy leaden weights of the ancient time piece. One weight was subsequently recovered, but the other was melted and run into bullets for use in fighting Gen. Washington's army.

### Syracuse.

Charles L. Becker, of Becker & Lathrop, returned Saturday from a week's stay in New York.

S. Harry Lesser, of A. Lesser's Sons, left last Monday for a three weeks' trip among his customers in Ohio.

It is 14 months ago that deputy Sheriff Kratz took Marcus Marks from his berth of manager for Zanoni, the mind reader, and brought him to Syracuse charged with having a hand in the theft of the tray of diamonds from Becker & Lathrop's store. Last August there was the trial and the disagreement of the jury. That cost the county \$2,500. Now there will be another trial, and it opens Monday morning. During all this time Marks and his alleged quondam partner in the tray of diamonds deal have known what it is to have their meals without the trouble of ordering them, and known where they were going to sleep every night.

### Last Week's Arrivals.

**THE CIRCULAR has perfected arrangements for obtaining the names and hotel addresses of all the latest buyers visiting New York, and each day posts in its office, 189 Broadway, a bulletin which every member of the trade is cordially invited to copy.**

The following out-of-town dealers were registered in New York during the past week: O. H. Fasoldt, Albany, N. Y.; Ashland H.; G. S. Prindle, Washington, D. C.; Hoffman H.; F. R. Biedler, Baltimore, Md.; Imperial H.; M. E. Mead, Chicago, Ill.; Normandie H.; E. R. Bennett, Amherst, Mass.; E. A. Rasch, Detroit, Mich.; Imperial H.; D. O'Hara, Waltham, Mass.; Astor H.; F. H. Noble, Chicago, Ill.; Park Ave. H.; R. E. Burdick, Cleveland, O.; Astor H.; L. Burt, Detroit, Mich.; Continental H.; A. Kurtzborn, Jr., St. Louis, Mo.; Waldorf H.; A. S. Mermod, St. Louis, Mo.; Westminster H.; E. B. Felsenthal, Chicago, Ill.; Holland H.; A. LaFrance, Elmira, N. Y.; Astor H.; E. D. Vosburg, Binghamton, N. Y.; Grand H.; J. G. Rosengarten, Philadelphia, Pa.; Grand H.; J. C. Hauck, Pittsburgh, Pa.; J. W. Field, Galveston, Tex.; Everett H.; E. Steinmeyer, St. Louis, Mo.; Morton H.; D. M. Marquardt, Des Moines, Ia.; St. Denis H.; A. Linz, Dallas, Tex.; Park Ave. H.; L. Linz, Dallas, Tex.; Park Ave. H.; T. Hurlbert, Philadelphia, Pa.; Westminster H.; J. F. Baumgardner, Toledo, O.; Westminster H.; T. G. Hawkes, Corning, N. Y.; Imperial H.; W. H. Rider, Danbury, Conn.; Continental H.

### IN EVERY HOME

There is a possibility of placing at least one of these beautiful groups.

Price of this one, \$10.00

A writer in the "New England Magazine" says, "There are few men in this country, among the artists, who know the horse as well as Rogers."

Send for Handsome Catalogue and Trade Prices.

**Rogers Statuette Co.,**  
441 Pearl St., N. Y.



## News Gleanings.

A. B. Kelly, Camp Point, Ill., died recently.

W. S. Bailey, Pomona, Cal., has released a mortgage.

W. F. Ott has opened a new jewelry store in Tulsa, I. T.

Fred. Schoulte, Port Huron, Mich., is advertising to sell out.

W. H. Appel, Lancaster, Pa., has moved to 1315 Hamilton St.

James Kelly, Bancroft, Ia., has given a bill of sale for \$1,143.

B. F. Lent, Sumner, Ill., has given a realty mortgage for \$175.

E. Rose, Joplin, Miss., has released a realty trust deed for \$5,800.

R. K. Henderson, Rudd, Ia., has given a chattel mortgage for \$330.

E. F. West, Plymouth, Ill., has given a chattel mortgage for \$175.

H. J. Bently is the successor to the Hanks' jewelry business, Postville, Ia.

A meeting of creditors of Reed McCraney, Martinez, Cal., has been called.

Topliff & Co., formerly jewelers in St. Paul, Minn., have been sued for \$767.

William H. Lynn, Stevens Point, Wis., has given a chattel mortgage for \$250.

C. P. Smith, Henderson, Tex., has advertised his jewelry business for sale.

A. C. Abeytia, East Las Vegas, N. M., is pronounced to be dangerously ill.

The effects of Sam Boukofsky, Oakland, Cal., have been attached for \$2,000.

E. J. Giering, South Bethlehem, Pa., has quit business and gone to New York.

W. F. Rust, Milbank, S. Dak., has added a stock of confectionery to his business.

J. J. Kelley has given a bill of sale of his jewelry business in Bancroft, Ia., for \$1,100.

The mortgagees are in possession of the jewelry store of J. L. Hosmer & Co., Kansas City, Mo.

Cox & Peden have succeeded to the jewelry business of Cox & Noltensmeir, Mt. Vernon, Mo.

Bert H. Weesner, Pawnee, Kan., has given a chattel mortgage on his jewelry store for \$116.

The manufacturing jewelry firm of Mathieu & Maison, San Francisco, Cal., have dissolved partnership.

J. Walter Ash, jeweler, Binghamton, N. Y., was fined \$25 for selling lottery chances on a watch. He paid the fine.

A certificate of incorporation has been granted the Kansas City Optical College, Kansas City, Mo.

Zach. Rice, jeweler, Landisburg, Pa., has purchased the property on Carlisle St., owned by Capt. Sheibley's heirs; price \$800.

Fred Law, foreman in the finishing department of the Manhattan Silver Plate Co.'s factory, Lyons, N. Y., died June 6. He was 38 years old.

A delegation of prominent Democrats waited on jeweler R. C. Hitchler, Nanticoke, Pa., last

week and requested him to be a candidate for Register of Wills.

The Hamilton Watch Co.'s factory, Lancaster, Pa., will take the usual Summer vacation of five weeks, closing on June 19th and opening on July 27th.

L. Thomas & Co.'s new optical parlor, Wilmington, Del., has recently been enlarged and refitted. Mr. Thomas is a graduate of the Philadelphia Optical College.

I. L. Pearl, jeweler, Mt. Carmel, Pa., who has been receiving expert medical treatment for sciatica, in Philadelphia, for several weeks past, has returned home much improved in health, but not entirely cured.

Stephen G. Massey, jeweler, 3d and Kerlin Sts., Chester, Pa., will occupy the store at 824 Edgemont Ave., recently vacated by Charles L. Dingler, who is now located across the street and has one of the finest fitted up jewelry establishments in the city.

The rays of the sun focussed through a reading glass in the window of Herman's optical rooms, Market St., Williamsport, Pa., at about six o'clock a few evenings ago, igniting a curtain. The blaze was discovered and extinguished, although not before considerable damage was done. The loss is estimated at \$45.

While Aaron C. Haag, watchmaker, Bernville, Pa., was working at his bench a few evenings ago, lightning struck his dwelling. The bolt passed into the cellar and thence up into the room, where it jumped from a lot of tools to the vice at which Mr. Haag sat. It then entered the drawers, melted tools, splintered a leg of the table, and finally entered Mr. Haag in the leg, ripping his trousers into shreds and tearing one of his shoes from his foot. Mr. Haag was hurled from his seat and his clothes were ignited. A red streak marks his leg where the electricity passed from the knee to the foot. Beyond a sensation of numbness, the man escaped injury.

"Our business requires more space. Under-selling department stores did it," is the terse inscription on a sign at C. F. Gillman's new store on N. Clark St., Chicago, Ill.

## Minneapolis and St. Paul.

Haldor Anderson, Michigan City, N. Dak., recently removed to Fessenden, N. Dak.

Chas. Beard, of Sischo & Beard, St. Paul, was married last week to Miss Helen Lovatt.

J. H. Bryant, for many years past with Bullard Bros., St. Paul, has quit the jewelry business.

W. B. Smith, St. Paul, has returned from the east and has opened in business again at corner of Robert and Sixth Sts.

Robert Reed, of the Reed-Bennett Co., Minneapolis, was elected delegate to the State convention that elects delegates to the National Democratic Convention to be held in Chicago soon.

Out-of-town jewelers visiting the Twin Cities the past week were: L. Schaeffer, Shakopee, Minn.; C. H. Todd, New Richmond, Wis.; A. Westerbaum, St. James, Minn.; O. W. Peterson, Hudson, Wis.; John Fredell, Center City, Minn.

Anton Peterson, jeweler, 28 years of age, residing at 249 Cedar Ave., Minneapolis, committed suicide some time last Saturday night or Sunday by shooting himself through the head with a revolver. Peterson came to this city from New York in the first part of April. The only cause for the deed that seems reasonable is that he became discouraged over business matters. He was, however, of a jovial disposition.

M. L. Cohen, jeweler, Minneapolis, has been at work on a handsome solid silver plate which is to ornament the convention table manufactured by Minneapolis students. The plate measures 6½ by 5 inches and in large black letters bears the inscription "Made for and used by the presiding officer of the National Republican Convention at Minneapolis, Minnesota, June, 1892, by the manual training department of the South Side High School." In the lower corner appear the names of Superintendent C. M. Jordan and Instructor M. H. Towner. This table will be used at the St. Louis convention by the presiding officer. After the convention the table will be on exhibition in the curio room of the State University.

"Sun"

NICKEL TIMER

WITH 30 MINUTE REGISTER.

\$4.25, less 6<sup>o</sup> for Cash.

BYRON L. STRASBURGER & CO.,

Importers of Watches and Makers of Diamond Jewelry,

11 MAIDEN LANE, NEW YORK.

THE STAR OF EMPIRE WESTWARD TAKES ITS WAY

# WESTERN SUPPLEMENT

## of THE JEWELERS' CIRCULAR

VOL. XXXII.

CHICAGO, WEDNESDAY, JUNE 17, 1896.

NO. 20

### Chicago Notes.

*All communications in reference to the Chicago department of The Jewelers' Circular, addressed to S. Parlin, 1527 Wrightwood Ave., Chicago, will receive immediate attention.*

The Elgin National Watch Co. are employing over 2,300 people at present and are keeping the working organization as near intact as possible in order that in the event of a revival of business they may keep pace with it. During the Summer the operatives are given a Saturday holiday. The company look forward to better conditions, dependent upon a general industrial improvement.

J. H. Leyson, Butte, Mon., returned home from a visit to his mother in Waltham, Mass.

William Shuttles, Jr., of W. Shuttles & Son, Dallas, Tex., will become a benedict in October, the bride-elect being a Dallas lady.

The Towle Mfg. Co. report quite an improvement in sales the past two weeks and regard the business situation generally as better than for some time past.

D. A. Wilkins, representing Ostby & Barton Co., and J. A. Limbach, for Foster & Bailey, leave for the Pacific Coast Friday of this week on a month or five weeks' trip.

E. B. Frank, Pairpoint Mfg. Co., left last week for a pleasure visit at Baltimore, Md., and Norfolk, Va. O. H. Hull is now on a vacation in Wisconsin.

Mr. Barker, R. Wallace & Sons Mfg. Co., reports from St. Louis the largest business he has ever secured there, and the Chicago salesmen report several large city orders.

L. D. Robinson, Washington, Ia.; Mr. Richards, El Paso, Tex.; H. C. Kachlein, Ft. Wayne, Ind., and J. W. Ford and M. V. B. Elson, Freeport, Ill., were among the buyers in the city last week.

A beautiful wheel has been on exhibition the past week at the Dearborn St. retail store of the Fowler Cycle Co. All metal work of the wheel was silver plated except spoke wires, which were gold plate. The frame and front fork were handsomely ornamented in raised mixed floral design of gold and silver in combination, giving the bicycle a rich appearance. The plating was done by the Sercomb-Sperry Co., 147 State St.

It will be a week or more before C. D. Peacock will get into his new quarters, northeast corner State and Adams Sts. In the opinion of many, the store will be the finest in the world, and Mr. Peacock quietly remarks that it is the model for this country. Of great assistance in reaching this result has

been the beautiful cabinet and show case work of A. H. Revell & Co., this city, for whom Mr. Peacock has words of warmest praise. C. D. Peacock will generally enlarge the departments for the new store, especially in leather and optical goods, and contemplates an entirely new feature, the addition of a department for society stationery.

### St. Louis.

Mr. Marx, of the Kossuth Marx Jewelry Co., New York, is in the city.

Col. Isaac Potter, Providence, State Committeeman for Rhode Island, came to the city on the 11th inst. and will stay here during the entire term of the convention.

E. Jaccard Jewelry Co. have received the contract for a solid silver loving cup to be contested for at a regatta to be given by the Interlake Yachting Club, at Put-in-Bay, O.

Henry Estinghausen, of the Attleboro Jewelry Co., arrived home Wednesday, and will go out again on the 15th inst. This time he will go to San Francisco, and expects to be gone six weeks.

J. C. Armstrong, Ottawa, Kan., ex-president of the Kansas Retail Jewelers' Association, is expected in the city on the 16th inst. to be the guest of Herman Mauch, president of the National Retail Jewelers' Association.

Mr. Hunter, the representative of Alex. Pirie & Co., paper manufacturers, Aberdeen, Scotland, was in the city on the 11th inst. calling upon some of our leading jewelers who make a specialty of carrying fine paper.

Walter W. Trigg, a jeweler, aged 24, left his home, 1622 Olive St., Wednesday morning last, and has not been seen since. His wife has asked the police to locate him. She knows no cause for his disappearance.

Louis A. Schoen, assistant manager of the Holmes & Edwards Silver Co., and of the Barbour Silver Co., this city, was married to Miss Malinda Yeager at the residence of the bride's parents, 3943 Vest Ave., on June 3d.

Among representatives of jewelry manufacturers in the city last week were: Mr. Hudson, H. F. Barrows & Co., North Attleboro, Mass.; Mr. Tiffany, F. H. Sadler & Co., Attleboro, and Mr. Sweet, Hayward & Sweet, Providence, R. I.

A prominent wholesaler told THE CIRCULAR correspondent that the ordinary link cuff-button is seldom called for now. The lever-link has taken its place and in his estimation it was only a question of a short time until

the latter would be used almost exclusively.

A number of visitors have arrived in town to be present at the excitement of Convention week. Among out-of-town jewelers in the city at present may be mentioned: John Earp, Le Mar, Mo.; Charles Miller, California, Mo.; C. J. Smith, Fairfield, Ill.; W. E. Clingenpeel, Eldorado, Ill.

### Kansas City.

A. Rush has taken a position with S. Streicher, as watchmaker.

J. R. Mercer left last week for an extended European trip. He will be gone until about the middle of August.

R. Michaels & Co. are disposing of part of their stock at auction, with auctioneer Chas. H. Manor in charge. Mr. Michaels is disposing of his surplus stock and will still continue business at his present location, 925 Main St.

The out-of-town buyers here last week were: H. M. Price, Chanute, Kan.; Jas. B. Hayden, Topeka, Kan.; S. H. Avey, Auburn, Neb.; L. H. Hoffman, Leavenworth, Kan.; J. L. Potts, Marceline, Mo.; J. J. Stott, Paola, Kan.

### Louisville.

George H. Kendrick has gone to Lagrange to spend the Summer.

H. H. Stein, traveling auditor for the Standard Oil Co. and a partner of G. A. Stein, the 4th St. jeweler, is in the city for a month's rest.

George H. Kettmann has perfected his arrangements to move to St. Louis and will leave July 1st. John F. Garland will still travel for the house. Mr. Kettmann will retain his same force of clerks. His address will be 104 N. 6th St.

Samuel Raff, a partner of Jules Steineau, has bought an interest in Lorch's wholesale store, on Main St. Mr. Lorch has bought Geo. H. Kettmann's fixtures, and will go on the road while Mr. Raff will have charge of the store. Mr. Steineau has made Mr. Raff an offer for his interest in the 4th St. store.

The Pestalozzi Jewelry Co., Milwaukee, Wis., June 9th, filed articles of dissolution with the register of deeds.

Richardson & Lineburg, Mt. Ayr., Ia., have dissolved as far as the jewelry branch of the business is concerned, the new firm being Richardson & Co., with Hugh Richardson as manager. Mr. Lineburg will continue as a member of the firm in the musical instrument line, taking active charge.

**Pacific Coast Notes.**

A jewelry store has been opened at Baden, Cal., by A. J. Potter.

O. H. Johnson, jeweler, Garfield, Wash., has filed declaration of homestead.

Claims amounting to \$13,500 have been filed against H. H. Day, Tacoma, Wash.

Carl King has purchased the jewelry business of L. A. Kerr, Kendrick, Idaho.

Chas. S. Carnes, late of San Jose, Cal., has opened a jewelry store in Healdsburg, Cal.

Frank Dobrowky has severed his connection with his father in the jewelry business, Redding, Cal.

J. Beck, Provo City, Utah, has removed to Barney's new store from his old location in the Pyne & Maiben drug store.

The dwelling house of Charles St. Louis, jeweler, Grant's Pass, Ore., was recently destroyed by fire. No insurance.

A. Kaiser opened his jewelry establishment in Sonora, Cal., recently and 450 persons registered at his store as visitors the opening day.

The jewelers of Eureka have signed an agreement to close their stores every evening at 7 o'clock. The agreement went into effect June 1st.

Powell Bros., Great Falls, Mon., have moved their jewelry store to 215 Central Ave., where, in addition to their jewelry stock, they will carry a full line of Lovell Diamond bicycles.

The sheriff at Great Falls, Mont., has received inquiry regarding George M. Mason, jeweler, also is wanted in Loveland, Col., on a charge of grand larceny. Mason is a very dressy fellow, and left Loveland, March 30, carrying away two trunks of silverware.

**San Francisco.**

L. Carrau, of Carrau & Green, is on a north-western trip.

The stock of Sam Bukofsky, Oakland, was attached June 2.

I. Zemansky, formerly of Sacramento, Cal., has opened a jewelry store on Kearny St., this city.

The San Francisco creditors of A. S. Joseph, Los Angeles, accepted 40 cents on the dollar in payment for their claims. Joseph owes for merchandise about \$2,500.

A special sale of jewelry was opened some days ago by A. Stefanoni, at the corner of 13th St. and Broadway, Oakland, under the management of Hugh Maulden.

**Detroit.**

E. H. Pudrith, with Eugene Deimel, has returned from a trip through Michigan.

G. G. Case, jeweler, Jackson, Mich., has removed to new quarters in Carter Bros. block.

The following out-of-town Michigan jewelers were here last week: Mr. Stevenson, Lewiston; D. B. Seeley, Milan; William Parks, Reese; C. E. Montford, Utica; and Mr. Van Stone, Saginaw.

Gustav Strengson, an old watchmaker and jeweler in the employ of Traub Bros., was killed last week in an elevator at 212 Jefferson Ave. Many years ago he was a watchmaker for Rolshoven & Co., and later started a jewelry store at the corner of Champlain and Antoine Sts. He removed to Woodward Ave.

Louis F. Lee last week stole a necklace and locket from the jewelry store of A. F. Toepel, 118 Gratiot Ave. The wife of the jeweler recognized him as a suspicious character, and tipped her husband. He got a club and held the young man at bay until officers arrived. The thief was recognized as a forger wanted for some time.

Webb C. Ball, Cleveland, O., was here last week en route home from Toronto. He was getting opinions on a new movement invented by him and manufactured by the Hamilton Watch Co., Lancaster, Pa., in which company he is interested. He is inspector for the Lake Shore Railroad and has reappointed Smith, Sturgeon & Co. local inspectors.

**THE PERFECTION SHOW CASE**

FOR FINE JEWELRY TRADE.

WE CHALLENGE THE WORLD TO PRODUCE ITS EQUAL.

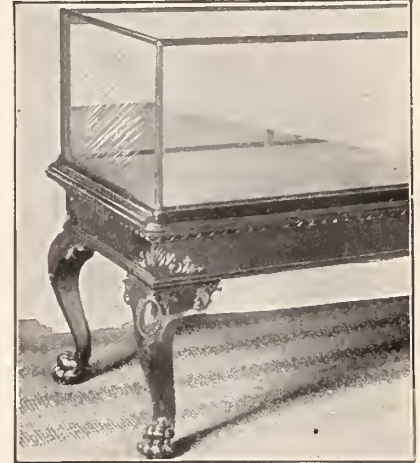

IF YOU ARE INTERESTED IN SHOW CASES AND JEWELRY FURNITURE, WRITE US FOR FULL INFORMATION.

**A. H. REVELL & CO.,**

431 to 437 Fifth Avenue, Chicago.

**AUSTRALIAN OPALS**

IN THE ROUGH. TRADE ONLY

ARTHUR F. CATE,

1125 WALNUT ST., - - DES MOINES, IOWA, U. S. A.

**PARSONS & SCHOOL**

FOR WATCHMAKERS,

PEORIA, - - - - - ILL.

Send for Circular and Terms.

PARSONS & CO

**ONE**

Agent wanted in every town to sell the

**STRICTLY HIGH GRADE**



**\$100.00 BICYCLES**

Write for Catalogue and Agents' Terms.

Send 10 Cents for Elgin King Scarf Pin.

Address Department B,

**ELGIN CYCLE CO.,**

ELGIN, ILL.

**TOWLE MANUFACTURING COMPANY,**  
**SILVERSMITHS,**  
**CHICAGO. NEWBURYPORT, MASS.**

JEWELERS ONLY.

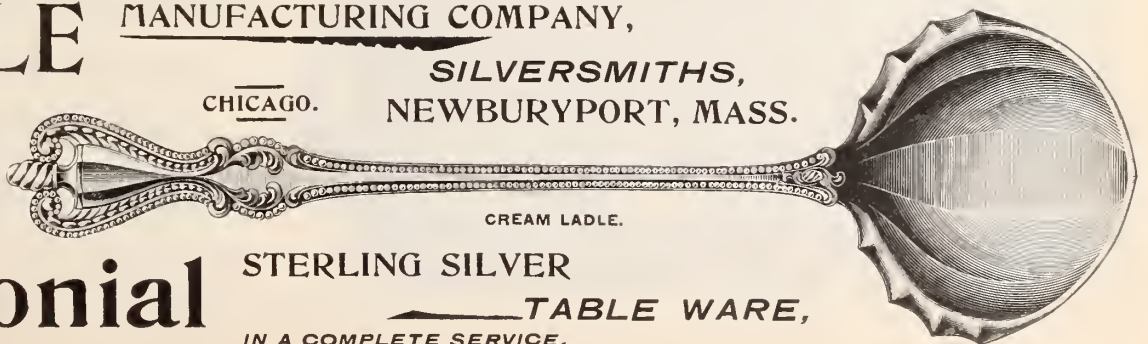

CREAM LADLE.

STERLING SILVER

TABLE WARE,

IN A COMPLETE SERVICE.



**Colonial**

where he was compelled to discontinue business. He has been in the employ of Traub Bros. for the last six years.

### Indianapolis.

J. C. Sipe has sold his fast pacer for \$1,000 Oscar Derndinger, Indiana man for Baldwin, Miller & Co., is in off the road.

Mr. and Mrs. J. E. Reagan have gone to housekeeping in E. C. Miller's house on North Delaware St. Mr. Miller and family have gone abroad for an indefinite length of time.

July 10 John Gardner expects to start on the road for the new wholesale house of Gardner & Ross. Just now the firm are busy buying their new line and arranging the stock. John Gardner and Fred Ross form the wholesale firm, while John Gardner, Edward Gardner, and Fred Ross form the retail and manufacturing firm of Gardner Bros. & Ross, 56 N. Penn St.

### Cincinnati.

Frank Herschede has moved into his new store on 4th St.

Inquiries at the factories elicit the same information: "We are still making school medals and pins."

President Herman, of the Board of Affairs of Cincinnati, has decided to have aluminium street name signs erected in the down town districts.

Joseph Becker, the Cincinnati representative of the Fahys Watch Case Co., and the

Brooklyn Watch Case Co., is east this week, visiting his firms.

It will be interesting to the old customers of Isa Schroder to hear that he will on his next trip carry a new side line, "The Little Red Men," which he will explain to them.

Bloom & Phillips are arranging for a large line of new samples in their sample room on 14th St., and will be able to show as pretty goods as seen on this side of the Alleghenies.

C. B. Goldsmith has returned from what he terms a purely social trip, as far as sales are concerned. In some places he was the guest of his customers several days, enjoying fishing, etc.

One of the live young jobbing houses of Cincinnati is pushing forward and will soon be domiciled in a whole building of three or four floors. The deal will soon be completed.

A. Herman, of D. Schroder & Co., struck a new customer up in the State, who is opening a new store, and now all the "boys" are trying to figure out who he is, so as to give him a call.

Mrs. Herman G. Huffman, wife of a well-known jeweler of Clyde, O., has sued for divorce, charging infidelity with various women in Clyde and a prominent society young lady of Maumee. The case has created much gossip and indignation in Clyde.

A wholesale presentation of gold Past Masters' jewels by Vattier Lodge, Free and Accepted Masons, will take place in this city within the next few weeks. The jewels have been made by Michie Bros., and are consider-

ed the most beautiful Past Masters' jewels ever presented in this city.

The Cincinnati Wholesale Jewelers' Association are trying to effect some kind of a credit system for mutual benefit, and will discuss the matter at an early date. There are a few houses in Cincinnati who have a thorough system, such as Oskamp, Nolting & Co. who have a system which covers east, south and far south-western fields, and it costs them a good deal of money each year to keep in touch commercially with this great territory. There are some houses who do not pay out a cent for information, while others pay large sums annually to Bradstreet and Dun for very meager information. If the forces combine, and each jobber conscientiously performs his duty, this large outlay individually can be largely reduced.

### New Jewelry Businesses.

Ernest Sudden, Brewer, Me.

Frank R. Cooley, Milford, N. J.

G. C. Lang, Eastman block, Barre, Vt.

G. Anderson, *Press* building, Belmar, N. J.  
Geo. Kerich, repair shop, Breckenridge, Mich.

H. J. Hittorff has resumed at 104 Lake St., Oak Park, Ill.

William Atherholt, 2204 W. 3d St., South Chester, Pa.

C. S. Schneider, Faribault, Minn., has recently gone out of the jewelry business, and is now running the Leland Hotel, Wells, Minn.



No. 1004 and 1008. Closed.

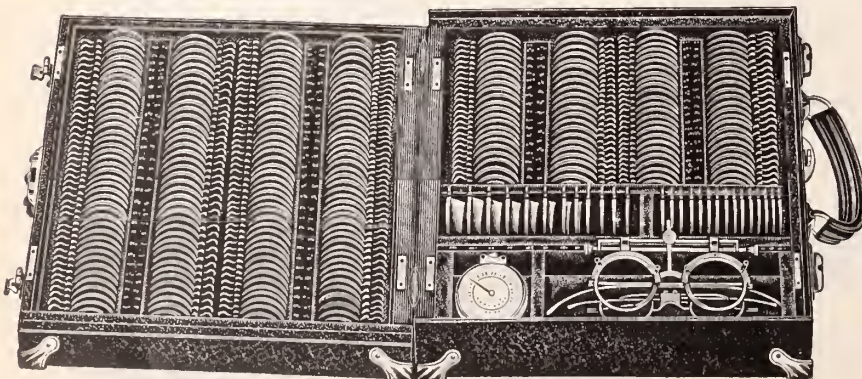

NEW STYLE FOLDING TRIAL CASES. No. 1004 and 1008. Open.

SEND FOR CATALOGUE AND MENTION JEWELERS' CIRCULAR.

"ALWAYS AHEAD"  
OTHERS FOLLOW.

# Geneva Optical Company,

67-69 WASHINGTON ST., CHICAGO.

## New Catalogue Now Ready.

**NEW PRICES**  
**NEW INSTRUMENTS**

For Oculists and Opticians.

Prescription Work to Order,  
Promptly and Accurately.

**Connecticut.**

The stock of Richard Noack, South Norwalk, has been sold at public auction.

Jeweler Chris Strobel, of Waterbury, has been appointed an alternate district delegate to the Chicago Democratic Convention.

Jeweler C. C. Carroll, Wallingford, has been receiving the congratulations of friends, the occasion being the arrival of a daughter at his home.

Charles Ernest died in Meriden, June 8, aged 64 years. He had worked as an inspector for the Meriden Britannia Co. nearly 40 years. He was one of the leading Germans of Meriden.

Noah Pomeroy, of Hartford, died in San Francisco, Cal., June 9, from an attack of pneumonia. Mr. Pomeroy was about 80 years old. He made a fortune in the clock-making business in Bristol.

James W. Clark, son of the Hon. Austin S. Clark, Hartford, and Miss Margaret George, of Chicago, were married at Mr. Clark's residence last Wednesday afternoon. The groom is a member of the firm of the F. E. Morse Co., dealers in diamonds and jewelry, Chicago.

The officers of the Middletown Plate Co and 50 others of Middletown's leading men on June 9 memorialized Senator J. W. Douglass, of that city, requesting him to use his influence to have the Connecticut delegates vote for McKinley at St. Louis on the first ballot.

The New Haven Clock Co., have taken out a city permit to erect a brick shop, one story high, 25 feet by 50, as an addition to their plant. Work at this establishment in the watch department continues very brisk, the hands working full time. In the marine and pendulum clock departments business is less active, the men working five days a week.

A rumor was in circulation last week to the effect that the E. N. Welch Mfg. Co. had been consolidated with the Waterbury Clock Co., and that the Forestville works would be started at once. A reporter made inquiries Friday afternoon and the fact of any consolidation was authoritatively denied. The company have commenced the repairs on the dam which was damaged by the three Spring floods, and it will soon be in shape so the pond can filled.

**Worcester, Mass.**

The Clark-Sawyer Co. have offered the Worcester Boat Club a beautiful silver loving cup for a series of pleasure boat races.

John B. Holmer, representing the Rochester Optical Co., Rochester, N. Y., has been spending several days in Worcester. He said to THE CIRCULAR reporter that as he sees it business in general has entered upon a revival.

Goldsmith & Frank, 14 Maiden Lane, New York, recently completed what they believe to be the largest ring mounting ever made. The ring is a flat band, one inch wide with a star set, and weights 48 dwts. A 7 karat diamond was mounted in the setting. The ring was made for a resident of Mobile, Ala. and was ordered through Julius Goldstein, jeweler, of that city.

**The Latest Patents.**

ISSUE OF JUNE 9, 1896.

**561,576. SKIRT-SUPPORTING BELT.** JOSEPH

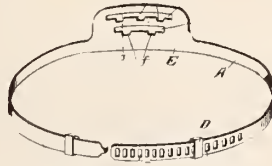

M. FLANNERY, Braddock, Pa.—Filed Feb. 17, 1896. Serial No. 579,559. (No model.)

**561,702. TIMING INSTRUMENT FOR VEHICLES.** EDWARD G. DORCHESTER, Geneva, N. Y.—Filed April 20, 1895. Serial No. 546,513. (No model.)



In combination with the wheel *a*, segment *C* pawl and ratchet transmitting motion from said segment to the wheel, the tumbler *15* actuating said segment, and the wheel *e* actuated by the wheel of the vehicle, the wheel *a* fixed to wheel *e* and provided with the teeth *a'* and the radially-movable pins *k* and the cam-ring *s* mounted revolubly on the wheel *a* and pushing by its cams the aforesaid pins outward to project from the teeth.

**561,802. MICROMETER-CALIPERS.** SAMUEL H. MARKHAM, Pittsburg, Pa.—Filed May 8, 1895. Serial No. 548,469. (No model.)

**561,893. EAR-RING.** VINCENT JANSKY, New York, N. Y.—Filed Mar. 27, 1896. Serial No. 585,040. (No model.)



An ear-ring, consisting of a front plate provided with a central screw-threaded stem that can be passed through the lobe of the ear, said front plate having a forwardly extending eye at its upper part, a setting or drop containing the diamond or other precious stone and provided with an eye engaging the eye of the front plate, said drop being arranged directly in front of the front plate and means applied to the screw-threaded central stem of the front plate for securing the ear-ring in position.

**561,897. COMBINATION-PENHOLDER** JONAS



A. LARSSON, Taluca, Ill.—Filed May 20, 1895. Serial No. 549,943. (No model.)

**561,930. STEREOSCOPE.** HENRY S. WALBRIDGE,

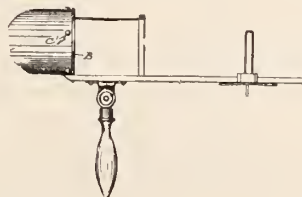

North Bennington, Vt.—Filed Nov. 23, 1895. Serial No. 569,914. (No model.)

DESIGN **25,600. POCKET-BOOK, &c.** PHILEMON O. DICKINSON, Newark, N. J.—Filed Apr. 30, 1896.



Serial No. 589,784. Term of patent 3 1/2 years.

DESIGN **25,601. POCKET BOOK, &c.** PHILEMON O. DICKINSON, Newark, N. J.—Filed April 30, 1896.



Serial No. 589,785. Term of patent 3 1/2 years.

DESIGN **25,603. EYEGGLASS HOOK.** STEPHEN J. CLULEE, Attleborough, Mass., assignor to the Bay State Optical Company, same place.—Filed March



18, 1896. Serial No. 583,818. Term of patent 7 years.

DESIGN **25,604. CANE HEAD.** JOHN T. MORRIS,



Baltimore, Md.—Filed May 12, 1896. Serial No. 591,298. Term of patent 3 1/2 years.

DESIGN **25,605. PAPER KNIFE.** HENRY C. KIRK,



Jr., Baltimore, Md.—Filed March 3, 1896. Serial No. 577,065. Term of patent 7 years.

TRADEMARK **28,349. WATCH CASES.** BATES & BACON, Attleborough, Mass.—Filed May 11, 1896.

**PURITAN.**

Essential Feature—The word "PURITAN." Used since February, 1891.

TRADEMARK **28,350. JEWELRY AND SILVERWARE.** THE STONE STERLING SILVER CO., New York, N. Y.—Filed May 6, 1896.



Essential Feature—Three "S's" pierced by an arrow. Used since April 1, 1896.

## Our Traveling Representatives



Traveling representatives may consider these columns open for the publication of any news or items of interest regarding themselves or their conferees.

THE following traveling salesmen passed through Detroit last week: C. Heller, L. Heller & Son; Mr. Sinnock, Ehrlich & Sinnock; Mr. Gregory, Strobell & Crane; Mr.

Parker, Osmun-Parker Mfg. Co.; Thomas Davis, Middletown Plate Co.; Mr. Tinker, for William B. Durgin; and Walter Shute, Day, Clark & Co.

Arrivals of traveling men in New Haven, Conn., last week were: James Donald, Ripley-Howland Mfg. Co.; Charles Ballard, Hayden W. Wheeler & Co.; Bradford B. Knapp; representative of Rogers, Smith & Co.; Mr. Hollister, Hollister Brothers; and representative of Wood & Hughes.

Among the representatives of leading jewelry houses in St. Louis the past week were: A. Kingsland, Reeves & Sillocks, Newark, N. J.; John A. Abel, Lewis, Kaiser & Luthy, New York; Chas. B. Bartlett, Whitney Mfg. Co., New York; and H. W. Sowade, A. J. Grinberg & Co., New York.

The travelers in Kansas City, Mo., last week were: L. Stern, Young & Stern; H. D. Mix, Wightman & Hough Co.; H. H. Bradley, E. A. Bliss Co.; M. S. Mills, Gorham Mfg. Co.; David E. Watts, Wm. Harvey & Co.; Mr. Gregory, Strobell & Crane, A. J. Sherrard, Enos Richardson & Co.; R. E. Kehl, F. H. Noble & Co.

Traveling men calling on Louisville, Ky. dealers last week were: Frank Stanborough, Carter, Hastings & Howe; A. Kingsland, Reeves & Sillocks; J. E. Bucher, Rogers, Smith & Co.; Albert Holzinger, for Fred. Kaufman; Charles B. Bartlett, Whiting Mfg. Co.; Mr. Foster, Unger Bros.; M. B. Markham, for A. Wolff; H. H. Bradley, E. A. Bliss Co., and Laurence H. Smith, Bippart & Co.

Included among the traveling men who visited Philadelphia, Pa., last week were: Frank P. Woomer, Mauser Mfg. Co.; Samuel E. Coggins, Towle Mfg. Co.; Thomas Smallwood, Jr., for J. Pouyat; Harry Beach, Wilcox Silver Plate Co.; Mr. Cheney, Ludwig Nissen & Co.; Mr. Bodenheimer, Fink, Bodenheimer & Co.; Mr. Larter, Larter, Elcox & Co.; Vincent P. Tommins, Middletown Plate Co.

Travelers in Pittsburgh, Pa., last week were: J. F. Dean, Reed & Barton; C. A. Boynton, Wm. B. Kerr & Co.; M. Stein, Wendell Mfg. Co.; A. Kingsland, Reeves & Sillocks; Albert Holzinger, for Fred. Kaufman; Frank L. Wood, Carter, Hastings & Howe; A. W. Atwater, Joseph Fahys & Co.; Mr. Goldberg,

W. & S. Blackinton; C. O. E. Hartung, Sussfeld, Lorsch & Co.; I. C. Nicholson, Flint, Blood & Co.

The Indianapolis, Ind., trade was visited last week by the following traveling men: W. A. Bigelow, W. H. Ball & Co.; Mr. Allen, C. H. Allen & Co.; Wm. Bosselman, T. Quayle & Co.; Louis Smith, M. B. Bryant & Co.; E. A. Tyler, Ansonia Clock Co.; J. M. Phillips, Hamilton & Hamilton, Jr.; R. Moorhead, R. L. Moorhead & Co.; Geo. C. Booth, Hutchison & Huestis; Geo. Pearse, Short, Nerney & Co.; J. S. Platt, Foster & Bailey; Mr. Solomon, C. P. Goldsmith & Co., and representatives of H. Wexel & Co., and F. Fonteneau & Co.

Among the travelers calling on Syracuse, N. Y., trade the past two weeks were: Harry C. Larter, Larter, Elcox & Co.; A. F. Carter, Sloan & Co.; P. H. Donner, for H. H. Kayton; W. H. Browne, Wilcox Silver Plate Co.; H. W. Frohlichstein, Henry Froehlich & Co.; George Ellsworth Herrmann, Gorham Mfg. Co.; Coleman E. Adler, Byron L. Strasburger & Co.; Arthur Lape, Simpson, Hall, Miller & Co.; Mr. Harris, for J. Goldberg; Mr. Baer, for Wm. I. Rosenfeld; D. Schwab, H. Z. & H. Oppenheimer; Frank W. Harmon, M. B. Bryant & Co.; John W. Case, H. F. Carpenter & Son; W. R. Shute, Day, Clark & Co.; Emil Meyer and Louis Oppenheimer, Max Freund & Co.; Fred. Clarkson, Snow & Westcott; Harry F. Hayes, Howard Sterling Co.; Mr. Whiting, S. E. Fisher & Co.; H. C. Van Ness, Unger Bros.; E. Horton, J. B. Bowden & Co.; F. G. Burgess, John Scheidig & Co.; E. C. McCarter, Whiting Mfg. Co.; J. M. Fisher, J. M. Fisher & Co.; C. Kettlely, Albro & Co.; S. Glenn Walmsley, Tenner & Baum; M. L. Hammel, Keller, Ettinger & Fink.

Traveling men visiting the Hub the past week included: Robert Hamilton, Hamilton & Hamilton, Jr.; C. E. Hancock, Hancock, Becker & Co.; Thomas G. Frothingham; George Osborn, William Smith & Co.; Ed. Gowing, Watson, Newell Co.; Mr. Stanley, T. I. Smith & Co.; George Parks, Parks Bros. & Rogers; Mr. Barker, Weedens & Barker; Mr. Marden, Marden & Kettlely; E. A. Potter; George L. Vose; Mr. Regnell, Regnell, Bigney & Co.; Mr. Case, Lord & Case; George H. Holmes; E. W. Holden; Mr. McDonald, McDonald, Culver & Teed; Mr. Kurtz, George W. Cheever & Co.; Mr. Grover, Grover & Gleason; Mr. Lincoln, Reed & Lincoln; Mr. Brower, R. L. Griffith & Son; E. B. Thornton; W. S. Metcalf, Plainville Stock Co.; Mr. Whiting, S. E. Fisher & Co.; E. L. Spencer; Mr. Bennett, Bennett, Melcher & Co.; Mr. Mowry, Kirby, Mowry & Co.; Mr. Knapp, Seymour-Knapp-Warren Co.; E. J. Ettlinger; Mr. Cobb, Cobb, Evans & Co.; Henry G. Thresher, Waite, Thresher Co.; Mr. Hildebrand, for H. C. Lindol; E. B. Kingman; W. D. Earl; F. L. Tappan.

### Wilmington, Del.

L. Thomas & Co. have enlarged their optical department.

Williard Davis is enlarging his already handsome store.

Harry E. Thomas, of H. E. Thomas & Co., is proud in being a father.

All the jewelers of Wilmington have decided to close their stores at 6 o'clock P. M. every evening except Saturday during the four months of June, July, August and September.

### Boston

Eben Hardy, the Province Court manufacturer of lenses, has a new yacht this season which was built for him down east. She is known as the *Magnolia*.

The June meeting of the New England Association of Opticians took place June 16th, at Young's Hotel. The feature of the meeting was an address from Dr. J. A. Tenney on "Operations on the Eye."

Buyers in town the past week included F. M. Nichols, Taunton, Mass.; Fred. H. Hendrick, representing A. P. Hendrick, Nashua; H. E. Washburn, Plymouth, Mass.; H. H. Snow, South Braintree.

The Central Plating Works, of Boston, have incorporated with a capital stock of \$5,000 in single shares of \$100. to do a general plating business. The promoters are: Elisha Otis, John C. Robinson and Harry E. McDonald. Charles F. Morrill says he shall commence tearing down the old building at the corner of Bromfield and Washington Sts. the first of August, and as soon as it is razed, he will erect a new tall mercantile building on the site, to be known as the Jewelers' Exchange.

The time of the Summer shutdown at the American Watch factory in Waltham is announced as beginning June 30 and ending Aug. 5. The employes are pleased with the assurance that the vacation will last but five weeks, as a longer period of idleness was anticipated.

Henry B. Lowery, a Boston young man, is wanted in Troy, and has been arrested in the Charlestown district on a charge of being implicated in a diamond robbery there last February. Counsel and friends of Lowery claim that the charge is a trumped up one and will fight the requisition of New York State for his extradition.

Some of the finest X-ray pictures that have been secured in Boston since the discovery of the process have been made by Fred W. Ruggles, head of Robbins, Appleton & Co.'s material department, with an electrical outfit, cabinet and photographic apparatus designed and constructed by himself. Some of his photos have been pronounced by scientists to whom they have been exhibited the best they have ever seen.

Among the jewelers, as well as in the optical trade, there are a number of enthusiastic yachtsmen, including the Percivals, father and sons, Charles F. Morrill, Reginald C. Robbins and several of the retailers. D. C. Percival launched last week his new knockabout, the *Sally*, successor to a boat of the same name which he had last season. D. C. Percival, Jr., has also just put in commission the yacht *Rondina*, which he sailed in a number of regattas last year. The new *Sally* is swifter than her predecessor, which was a prize winner with a proud record.



### New Way of Arranging the Barrel in Stem-winders, Etc.

WHEN in a barrel of the ordinary style the mainspring breaks, says M. Kopp, of Hohenstein, Germany, the inventor of the following device, in the *Deutsche Uhrmacher Zeitung*, serious damage is frequently done to the train; the pieces of the spring, which are forced apart with great violence, one of

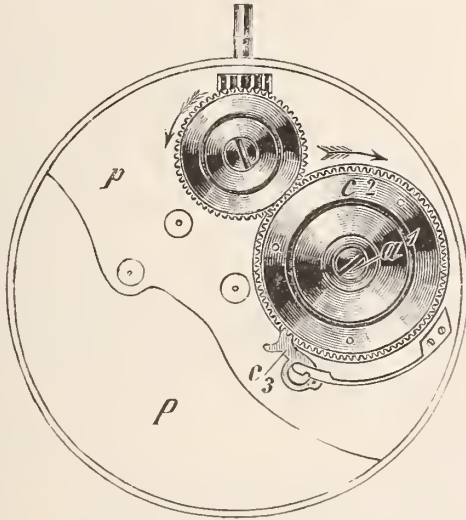

Fig. 1.

which pieces remains connected with the side of the barrel, fly against the sides and impart a terrible jar, whereby the teeth of the barrel or the lever of the center wheel are often bent, if not broken. To avoid these disagreeable consequences of the breakage, and at the same time simplify the putting in of a new spring, I have devised the following arrangement of the barrel:

Fig. 1 is the plan, Fig. 2 the cross section of stem-winder, in which the barrel is placed in

fits precisely, but without pinching, upon the square part  $b^1$  of the steel part  $bb^1$ , Fig. 4. In other respects, the barrel F, together with the cover  $d$  runs upon the core  $cc^1$  in the usual manner.

The parts shown in Figs. 3, 4, 5, are mounted in such a way that the great wheel  $f$  is with the pipe  $b$  first pushed upon the stud  $a$ ; next comes the barrel F with the core  $cc^1$  upon the square  $b^1$ , and finally the whole is fastened with a screw  $a^1$  with a small disc un-

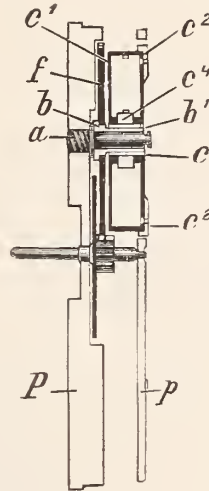

Fig. 2.

derneath, entering into the stud  $a$ , Fig. 3. This permits both the turning of the great wheel  $f$  upon the stud  $a$ , and that of the barrel F upon the core  $c^1$ .

The barrel ratchet  $c^2$ , Figs. 1 and 5, is with several screws fastened upon the barrel F. The spring hooks are disposed of in the ordinary way; one on the core, one on the barrel. It will be seen from above description however, that in winding the watch not the core is turned but the barrel. Since,

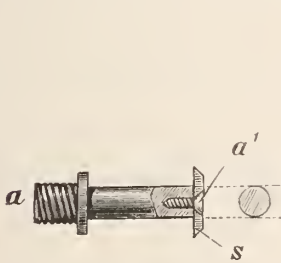

Fig. 3.

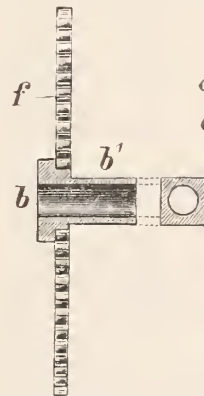

Fig. 4.

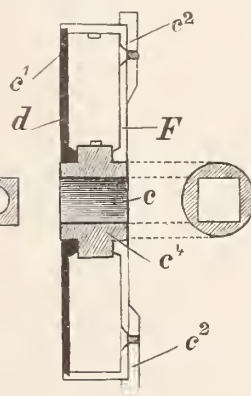

Fig. 5.

the new manner.  $P$  is the movement plate,  $p$ , the three-quarter plate. In Figs. 3, 4, 5 the several parts of the barrel are represented;  $a$  is a heavy steel stud screwed into the movement plate  $P$ , and serves as pivot for the great wheel  $f$ , which is riveted upon a long steel pipe  $bb^1$  (see Figs. 2, 3, 4). The front (or upper) part  $b^1$  Fig. 4, of this steel pipe is shaped square outside. The core  $c^1$ , Fig. 5, is furnished with a square perforation  $c$ , which

now, the large wheel is entirely separate from the barrel, the jar occasioned by the breaking of the spring, can be exerted only upon the teeth of the ratchet wheel or click, consequently upon parts sufficiently strong to resist even the most violent shock of this kind without damage.

Another advantage of this arrangement is that the barrel, when a new spring has to be put in, can be withdrawn with great ease

from the movement. When the click  $c^3$  (see Fig. 1) is turned about one quarter of a turn to the left—whereby the pin at its head drops in the small notch of the clickspring, thus holding the click secure in this position—it is simply necessary to loosen the screw  $a^1$  after which the barrel can be lifted from the stud; or else the movement may simply be turned around after having loosened the screw and the barrel falls off readily.

The great wheel may also be retained upon the stud by a locking screw in a suitable place in the plate, by which it is secured with sufficient shake at the toothed rim. The barrel may also be arranged in this manner in mantel clocks or large music boxes, for which a breakage of the mainspring is still more injurious.

### Workshop Notes.

**Hot Sawdust.**—Let me call the attention of the advantage of using the sawdust hot. It does the work in one-fourth the time, and is much more satisfactory.

**Oiling Cannon Pinion.**—When putting on the cannon pinion, see that it is tight enough, and give it a very little oil, as the friction then lasts better than when it is dry.

**Balances.**—A gold balance is preferable to one of steel. It is true, this metal has the advantage of being less affected by alterations of temperature, but on the other hand, gold is not liable to rust or to magnetism.

**Burnishers.**—The surface to be burnished must be free from scratches, which the burnisher does not remove, but renders more distinct by contrast; and the burnisher must be kept highly polished, for the surface burnished can never be smoother than the burnisher. Burnishing polished pivots with the glossing burnisher preserves them from wearing. Very little if any, of the metal is removed by burnishing in the ordinary way, although watchmakers sometimes use what are called cutting burnishers to form pivots. The cross section of these burnishers scratches the outline of the pivot it is desired to form, and they are roughened by rubbing on a lead block charged with coarse emery. The pivot is finished with a smooth burnisher. Silver-smiths use burnishers of agate.

**Reducing Pallet Drops.**—If the repairer has done any work on clock pallets, which necessitated filing and closing them, he will find when placing them in the frames along with the scape wheel that the "drop" in the perpendicular pallet has increased considerably. This drop can be reduced by altering the front pivot hole of the pallets, or by taking the steady pins out of the back cock and moving it down, or by both methods, care being taken to steady-pin the back cock in its new position after moving it. The drop of the horizontal pallet can only be altered by bending the pallets in the vise. The acting faces of the pallets, if it be a re-coiling escapement, should be shaped so as to produce a slight recoil or retrograde motion of the escape wheel, after a tooth has escaped from the one pallet on to the other.

DEPARTMENT OF  
**ADVICE AND CRITICISM**  
 ON  
**RETAIL JEWELERS' ADVERTISING.**

BY ALFRED MEYER.

[This department is absolutely free to every retail jeweler and optician. Forward for criticism your newspaper ads., booklets, catalogues, novelties, circulars, etc. Ask advice and offer suggestions. Replies in these columns are unbiased. Please make letters as brief as possible. Every letter and ad. sent will receive full attention, though the publication of the matter may sometimes be delayed a week or two. Address letters and other matters to The Jewelers' Circular Pub. Co., 189 Broadway, New York.]

PART XVII.

WITH the following letter, Hardy & Hayes, Pittsburgh, Pa., sent six ads., each occupying a space of 3½ inches double column.

PITTSBURGH, Pa., May 18, '96.

Editor of THE JEWELERS' CIRCULAR:

GENTLEMEN: We send you a half dozen of our ads. for criticism, etc. These are from our swell society paper. They appear always on the personal column page and next reading matter. We always take a text and try to drive home a single idea, sometimes with prices, and sometimes without. We have read with much interest your criticisms and jewelers' ads. and trust you may keep it up.

Yours, HARDY & HAYES.

By J. Hardy.

Taking them all in all the ads. are too general, though one idea is embodied in each. They are "talking ads." rather than "selling ads." It is prices, descriptions of articles, and a good, sound reason for the prices being low that impress the shopper. We reproduce the six ads. here. The first ad. is the best of them.

merchants. They are one of Pittsburgh's finest houses. If this dry goods house carries nothing in the line of jewelry, or whatever a jewelry house like Hardy & Hayes carries, I consider it a good point to use such a house as Hugus & Hacke as a lever to draw trade. It is good advertising for both houses, for the reason that when Hardy & Hayes' ads. are read, and the words "next Hugus & Hacke" noticed, the reader may be put in mind of this, that, or the other thing needed from both stores. The use of the name of a fine house, of one that has long been established and is well known, creates a better impression than the number of the jewelry store. However, should Hugus & Hacke carry goods such as are likely to be found in a jewelry store such as that of Hardy & Hayes, advertising a competitor would be a detriment to the jewelry store. If Hugus & Hacke have a jewelry

duced on next page were received. The first ad. headed "Gifts That Are Sensible" occupied 8 inches of news-paper space.

The other one headed "Perhaps You'll Decide To-day," took up 6 inches of space.

Both ads. are of a convincing nature. The first is especially good, because it quotes prices. If D. F. Sullivan would continually give in his advertise-

...Superb Easter Display...

Dainty Novelties  
 in Silver

FROM 25C TO \$500.

HARDY & HAYES,  
 JEWELERS,

Phone 2357 211 Fifth Avenue Next Hugus & Hacke.

Dainty  
 Enameled Watches,

With beautiful Pins to match, in Fleur-de-lis, Bugs, Twists, Hearts, Ties, etc., are the latest fad. Come and see the lovely ones we have, and at prices that will surprise you.

Hardy & Hayes,  
 JEWELERS,

Phone 2357.  
 Next Hugus & Hacke. 211 Fifth Avenue.

Chests Filled with Silver...

Superb special ones just fitted up. Common sense ones in compact cases. In fact, all kinds. This is the Family Gift. It lasts for generations and is always referred to with pride. We can fit up a handsome chest from \$20.00 to \$1000.00. Estimates given with pleasure. Your inspection solicited by

Hardy & Hayes,  
 JEWELERS

Phone 2357  
 Next Hugus & Hacke 211 Fifth Avenue.

The Libbey Cut Glass

Is the kind we sell. Stands highest, sells best. No foreign trash sold by us. The Libbey is the clearest, deepest cut and most brilliant cut glass made. It is surprising what a nice piece you can get from us at \$5.00 to \$10.00.

HARDY & HAYES,  
 JEWELERS,

Phone 2357  
 Next Hugus & Hacke 211 Fifth Avenue.

Our Silver  
 Department

Is in the rear of the store, away from the hurly-burly. Comfortable rocking-chairs and tables make it a comfort to shop here. Everything you want from a 25c. salt spoon to a \$1000.00 chest of silver. No trouble to show goods. We will be glad to see you to give you ideas at

HARDY & HAYES,  
 — JEWELERS, —

Phone 2357.  
 Next Hugus & Hacke.

211 Fifth Avenue.

I am going to say something about Hardy & Hayes' address. I find reasons for upholding their present method, and reasons for condemning it. Hardy & Hayes' address to their ads. is as follows:

HARDY & HAYES,

Jewelers.

211 Fifth Avenue.

Phone 2357.

Next Hugus & Hacke.

The point to be criticised is their using the phrase "next Hugus & Hacke," in their advertisements.

Hugus & Hacke, to the best of my knowledge, are retail dry goods

department, I would advise Hardy & Hayes to drop using in their ads. "next Hugus & Hacke," for it is unwise to give free advertising to a direct competitor. In such an instance it would be best if Hardy & Hayes would say in their ads. "near to . . . Street."

\* \* \*

IN THE CIRCULAR of May 27th was reproduced and criticised in this department one of the ads. of D. F. Sullivan, Rockford, Ill., and because the writer considered the ad. very good, asked for more printed matter issued by this firm. In response the two ads. repro-

ments the description of an article with price, just as he did in the ad. reproduced in the issue of May 27th, and be as sound with reasons as he has been with the three ads.

## Perhaps You'll Decide To-Day . . . . .

What to buy for Wedding or graduating gifts.

## We Have

The newest gifts, the gifts that last longest and look the best and please the most people. All the popular fads and fancies. We've something for EVERYBODY, from a few cents to as many dollars.

**D. F. Sullivan,**  
JEWELER.

## GIFTS

That are Sensible. . . .

Not gifts of a day's delight, but gifts for a lifetime. Gifts that keep the memory of the giver always before one. Gifts that last as long as friendship—those are the sensible gifts.

### WATCHES.

We have two hundred to show you; some reliable and very pretty ones as low as \$10 Dainty long chains to go with them as low as \$2, yet reliable.  
No better graduating gifts.

### RINGS.

In Diamonds, Opals, Pearls, etc.—from \$2.85 to \$15 and up. These are much appreciated gifts and last for years as a reminder of the giver.

### WEDDING RINGS.

We have them, the best the goldsmith makes—14, 18 and 22k.

**D. F. SULLIVAN,**  
JEWELER.

submitted, he certainly will have some of the best and cleanest ads. in the jewelry line in this country.

This ad. of J. Goldstein, Mobile, Ala., is

## DON'T TELL YOUR FRIENDS



That your goods come from our store—if bought elsewhere—It's not fair to us, because we sell only first class, warranted.....

JEWELRY, WATCHES AND DIAMONDS.

## WE PRIDE OURSELVES

On the excellence of our goods—

Silver Ware, Cut Glass and Jewelry.

Our Prices always reasonable.

**J. GOLDSTEIN,**  
60 Dauphin Street.

nically set up and is fairly well written. It needs only to be supplemented with a list of articles and prices to make it a business-bringing ad.

## Imports and Exports for April, 1896, and the Preceding Ten Months.

WASHINGTON, D. C., June 8.—The summary statement of imports and exports for

Jewelry, etc.....	\$49,306	\$66,744
Precious stones, etc.....	22,277	18,070

There is a jeweler in the Bowery whose window display is unique. Among the articles is a massive sterling silver spade, with a three-

### IMPORTS OF MERCHANDISE.

ARTICLES.	APRIL.		TEN MONTHS ENDING MARCH—	
	1895	1896	1895	1896
	Values.	Values.	Values.	Values.
CLOCKS AND WATCHES, AND PARTS OF:	<i>Dollars.</i>	<i>Dollars.</i>	<i>Dollars.</i>	<i>Dollars.</i>
Clocks and parts of.....dut...	31,032	38,698	272,456	477,850
Watches, watch materials, and movements.dut...	82,032	74,449	856,437	948,015
JEWELRY, MANUFACTURES OF GOLD AND SILVER, AND PRECIOUS STONES:				
Diamonds and other precious stones rough or uncut, etc.....free...	9,934	20,778	547,079	104,372
Jewelry, and manuf'r's of gold and silver...dut...	97,289	34,617	549,040	931,876
Precious stones, and imitations of, not set...dut...	62,5339	429,102	5,860,486	5,391,699
Imported from—				
United Kingdom.....	4,920	2,075	380,049	43,253
France.....	197	75	71,246	1,545
Netherlands.....		16,788	49,783	16,963
Other Europe.....	4,314	1,846	34,191	41,587
Brazil.....	593		11,367	
Other countries.....			443	1,024
Total diamonds, etc.....	9,934	20,778	547,079	104,372
United Kingdom.....	247,584	131,874	2,264,755	1,996,918
France.....	126,195	57,209	1,270,516	1,497,771
Germany.....	24,446	21,748	271,419	358,286
Netherlands.....	240,670	104,563	1,555,404	1,193,402
Other Europe.....	74,271	140,244	637,832	1,225,762
British North America.....	30	4,770	86,277	19,225
Mexico.....	351	334	8,591	24,168
East Indies.....	6,281		6,942	297
Other countries.....	2,800	2,077	7,490	8,046
Total jewelry, precious stones, etc.....dut..	722,628	463,719	6,409,526	6,323,875

### EXPORTS OF DOMESTIC MERCHANDISE.

CLOCKS AND WATCHES:				
Clocks, and parts of.....	62,734	89,655	697,305	744,880
Watches, and parts of.....	35,281	43,150	288,137	424,861
Total.....	98,015	132,805	985,442	1,169,741
Jewelry, and manufactures of gold and silver..	59,392	60,700	595,427	717,346
Plated ware.....	24,361	27,466	284,503	344,381

### EXPORTS OF FOREIGN MERCHANDISE.

CLOCKS AND WATCHES, AND PARTS OF:				
Clocks and parts of.....dut...			137	311
Watches, and watch materials, etc.....dut...	2	806	113	8,609
JEWELRY, MANUFACTURES OF GOLD AND SILVER, AND PRECIOUS STONES:				
Jewelry, and manuf'r's of gold and silver...dut...	3,396	3,508	66,723	38,860
Precious stones, and imitations of, not set...dut..		189	1,161	19,076

the month ending April 30, 1896, and the ten months ending the same date, compared with the corresponding periods of 1895, has been issued, and contains the above figures relative to the jewelry trade.

The merchandise remaining in warehouse on the last day of April, 1895 and 1896, respectively, was as follows:

	1895	1896
Clocks, etc.....	\$41,676	\$52,424
Watches, etc.....	15,816	37,028

foot handle of costly wood that is silver bound. It bears this inscription: "This spade was used by the Most Hon. the Marquis of Normanby, Governor of Queen land, on Jan. 30, 1873, when His Excellency turned the first sod of the Brisbane and Ipswich Railway." Why is that spade on the New York Bowery?—*New York Evening World.*

Louis Hanson, lately of Menomonee, Wis., has removed to River Falls, Wis.

# OPPENHEIMER BROS. & VEITH,

CUTTERS OF DIAMONDS,

DEALERS IN WATCHES,

65 NASSAU STREET (PRESCOTT BUILDING), NEW YORK



NO  
SOLDER.

NO  
SEAM.

SAVE TIME AND MONEY.

Superior to Anything Ever Shown.  
Apply for Catalogue to

**CHAS. BACHEM,** 249-251 N. J. R. R. AVE.,  
NEWARK, N. J.  
Manufacturer of

Marquise Heads, Clusters, Ring Shanks, Gypsy Rings, Etc.

## Advertising Cuts

Specially Designed for JEWELERS'  
ADVERTISING, such as above, at  
75 Cents per Electrotpe.

SEND FOR PROOF SHEET.

THE JEWELERS' CIRCULAR PUB. CO.,  
189 Broadway, New York.



WE HAVE  
ON HAND

A Large Number of Small

These well-known Razors, the quality of which is warranted, possess this great advantage, that they may be used for ten years before they require actual sharpening. Before using them, it is necessary to rub them on good leather strop. Lecoultre's Strops (to be had with the Razors), should be used in preference to others.

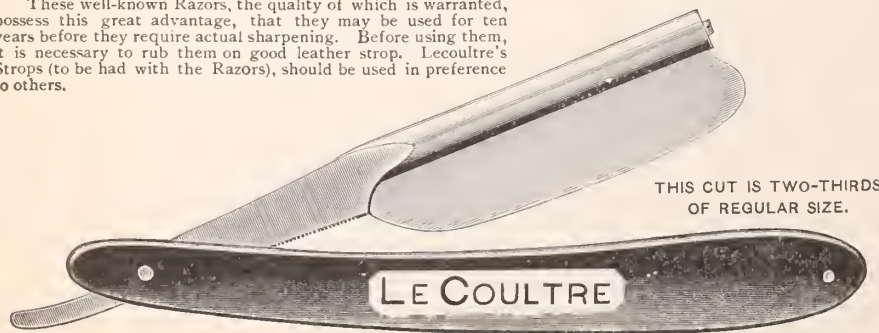

THIS CUT IS TWO-THIRDS  
OF REGULAR SIZE.

LE COULTRE

**MATHEY BROS., MATHEZ & CO.,**

SEND FOR  
PRICE LIST

SOLE AGENTS. 21 & 23 Maiden Lane, N. Y.

ESTABLISHED HALF A CENTURY.

**MARVIN'S**  
FIRE & BURGLAR  
**SAFES**

HAVE MANY PATENTED IMPROVEMENTS  
NOT FOUND IN OTHER MAKES  
THAT WILL WELL REPAY AN  
INVESTIGATION  
BY THOSE WHO DESIRE TO SECURE  
THE BEST SAFE  
MARVIN SAFE CO.

12 PARK PLACE, NEW YORK.

## ENAMELERS

OF GOLD, SILVER AND PLATED JEWELRY,  
Enameled, Plain and in Colors

ALSO OF  
SOCIETY EMBLEMS,  
YACHT AND COLLEGE FLAGS.  
All Varieties of Painted Enamel Work.

## S. S. WILD & SON,

179 Eddy Street, PROVIDENCE, R. I.

Correspondence Solicited.  
Telephone Connection.

## DR. KNOWLES' PRIVATE COURSE IN OPTICS.

Lectures with Diploma \$25.00  
Those who desire to study with the Doc-  
tor will send in their application.  
Students received at any time.  
CORRESPONDENCE COURSE PERFECTED.  
The Key to the Study of Refraction.  
50c. per copy,

For Sale by  
R. H. KNOWLES, M. D.,  
189 Broadway, NEW YORK.  
Care of JEWELERS' CIRCULAR.

## A. J. COMRIE,

AUCTIONEER,  
22 John St., N. Y.  
SPECIAL SALESMAN OF WATCHES, DIAMONDS,  
BRIC-A-BRAC, FOR ESTABLISHED JEWELERS.  
WRITE FOR PARTICULARS

ALL KINDS OF  
**S KELETON S**  
FOR  
SILVERSMITH  
MANUFACTURED BY  
**CHULDER BRO**  
FACTORY AT SOLINGEN, GERMANY. FOUNDED 1850  
545 & 647 PEARL ST., NEAR BROADWAY, NEW YORK



## The Rambler's Notes.

WHAT THE RAMBLER SAW AND HEARD AMONG THE DEALERS IN ART POTTERY, CUT GLASS, BRONZES, ETC.

### BEAUTIFUL CORDIAL SETS.

IN direct contrast with their many intricately cut decanters and glasses, are the cordial sets now shown by C. Dorffinger & Sons, 36 Murray St., New York. These sets have but little, and in many cases no cutting whatsoever, but owing to their graceful shapes and beautiful polish and color, they are worthy to be ranked with the finest productions in crystal. They consist of a decanter or jug and six glasses. The jug is in several instances silver mounted and with the glasses shows the mark of the cutter's wheel only at the base. One set contains a jug of yellow glass, the small glasses having crystal stems and yellow bowls decorated with gold.

### A NEW PROCESS IN CHINA DECORATING.

THE interest of amateur and professional china decorators as well as that of dealers in fine china, will, no doubt, be centered on the new trays and plates produced by the Art China Decorating Co., decorated by what is said to be an entirely new process. The beautiful floral decorations these pieces contain are not only rich and artistic but absolutely natural and have been produced by photographing flower sprays directly upon the china and then painting the impressions in natural colors. It will be seen that conventionality is here absolutely eliminated from the design and nature substituted, giving the pieces so decorated an indescribable charm that is seldom met with in commercial productions. Levy, Dreyfuss & Co., 11 Maiden Lane, New York, who control the product of the Art China Decorating Co., are showing a variety of these plates and trays.

### POPULARITY OF THE "PALMETTO" CUTTING.

FEW patterns in the cut glassware of T. B. Clark Co. have ever attained the popularity that their "Palmetto," a cutting of this Spring, now commands. Originally used almost exclusively in champagne jugs, vases and other slender pieces, it is now cut in almost all the articles made by this company, and has

proven as adaptable for and as beautiful in the small pieces as the tall vases. Among the articles in which the "Palmetto" has recently appeared are small ice tubs, small footed bowls and cheese dishes with covers. A new and extra tall jug has just been produced by the T. B. Clark Co., and may be seen at their salesrooms, 860 Broadway, New York. The jug is 16 inches high and is cut in all patterns.

### NEW LAMPS OF THE PHOENIX GLASS CO.

A NOVELTY of distinctly Oriental inception is to be seen in the dainty perfume lamps shown by the Phoenix Glass Co., 42 Murray St., New York. They are about the size of the small princess lamps but have no globes and burn perfume by means of a hot carbon. The decorations of these lamps are delicate and artistic, and show many styles and varieties of treatment. An intermediate grade of large banquet lamps has succeeded the rich line of special lamps recently mentioned. The new assortment contains beautiful pieces, banquet size, decorated in Empire and Colonial styles.

THE RAMBLER.

### A Clock Made of Bread.

BREAD is the most curious material out of which a clock has ever been constructed. There was, and may still be, in Milan, a clock made of bread. The maker was a native of Milan, who devoted three years of his time to the task. He was very poor, and, being without means to purchase the necessary metal for the making of a clock, he set apart regularly a portion of his bread each day, eating the crust and saving the soft part. To solidify this he made use of a certain salt, and when the various pieces were dry they became perfectly hard and insoluble in water. The clock was of fair size, and kept good time.—*Philadelphia Record.*

Louis Weber, jeweler, Lancaster, Pa., at the close of the season will give a handsome solid gold locket set with nine diamonds to the most popular member of the Lancaster Club. The player receiving the greatest number of votes will get the locket. Any person above 15 years of age may vote by calling at Mr. Weber's store.

## Modern Cut Glass.

CUT glass was formerly for the few. Since its manufacture has been greatly extended in this country, it is now within the reach of a greater number. In common use the pressed and the blown glass take no mean place among the products of science. They are now made so delicate, clear and sparkling that the better specimens are not to be lightly esteemed. Among them are those thin tumblers that by the sand-blast process of engraving are decorated with a multitude of designs, such as arabesques, flowers and monograms.

A visit to any of the large glass establishments in our cities will convince the most conservative person that American cut glass is the finest in the world. The first thing to catch the eye are lovely rose bowls that, while transparently showing the stems of blossoms, enhance their brilliance by their iridescence. They are spherical in form, with truncated poles, so that while standing with broad bases so as to be not readily overturned, they can receive a large handful of spreading sprays. These bowls are, in fact, desirable for almost every flower that grows. The tall vases are equally appropriate and elegant and range from 15 to 18 inches high.

Turning from these accessories to articles of table use, we learn that the individual salts are not wholly banished from the good graces of some families. Beside them are knife rests, mustard cups, with silver tops, of a variety of sizes, and bottles into which is poured Worcestershire sauce from the unsightly receptacle in which it comes from the market. There are also oyster sets—holding pepper, salt, mustard and sauce—and cruets not yet banished on account of their convenience. Coming to compote and berry dishes, we find an array long and bewildering. There are numberless bowls suited alike to ice cream, salads, berries and punch, which will be appreciated by housewives with modest incomes. This same class will also prize the locked liquor sets with polished wood frame and cut-glass bottles. These cases are open, showing the rich cuttings, yet so made that they can be locked at one end, thus being safe from light fingers. A writer in *The Decorator and Furnisher*, who calls attention to the foregoing, along with numerous other articles, decorated and useful in cut glass and crystal, says:

To show cut glass at its best there should be provided in the dining-room a corner cabinet, with many shelves and glass doors. Back of the shelving should be felt or plush of some dark, rich coloring that harmonizes with the other furnishings, such as ruby or plum. Arranged on these shelves, with the smaller pieces in front, these fine accessories of the table are always in evidence.

To show the brilliance of their facets requires much attention. Cut glass should be washed in warm suds with a brush, moderately stiff, but not harsh. With it every crevice must be entered, since dust mars its peculiar iridescence. It may be rinsed in warm water, and then, if the pieces are not too large, plunged into sawdust to dry. Then brush again with a dry, soft whisk and you have the facets sparkling like the diamonds they so much resemble. Where the sawdust is not practicable, wipe the articles with tissue paper until every particle of moisture is absorbed. This is almost as good as to use the sawdust.—*Syndicate Article of American Press Association.*

### Swiss Watchmakers and Factories.

It is most interesting to compare the different methods by means of which the highest grade of mechanical perfection is attained in various countries, says a writer in *Cassier's Magazine*. Notwithstanding the high character of American watches, for example, the finest Swiss watches still maintain their great reputation. The Swiss workman receives the

parts from the manufacturer in the rough, takes them to his home, puts his best individual skill into the finishing and assembling, and brings the completed watches to his employer. The latter inspects the work, and out of a batch of, say fifty, watches, he selects five or six as worthy of his own attention and puts the others into his regular trade under one general trade name. The selected watches he readjusts, working over them for days, weeks, and months before he considers them worthy to bear his own name, and it is these watches which go to those who have not only the money to buy but also the patience to wait.

A prominent firm of American jewelers, chafing under the inconvenience of this old world method of doing things, sought to introduce American methods and see if the highest grade of Swiss watches could not be made more methodically. A factory was built, enticing rates of wages were offered to the most skilful workmen, and the experiment was tried. But, alas! the Swiss workman soon found out that no regular wages could pay him for his loss of liberty. To be on hand when the whistle blew in the morning, to have his stated hour for dinner and his fixed hour for quitting at night—these restrictions he could not long stand. Formerly he had worked when he felt like it and stopped when it pleased him, and when he was paid for one job he took his time to begin with the next, generally waiting until his funds ran low. The factory plan did not work for long, and the idle building now bears silent testimony to the Swiss love for independence, which is as much a factor in

present life as it has been in past history.

The fact that much of the work of the Swiss watchmakers and instrument makers is done in this primitive manner does not in the least detract from its high quality, but it rather adds to its perfection by embodying in each article the individual skill of the workman. The writer desired to procure one of the famous Goldschmidt aneroid barometers, and only after some difficulty and many inquiries did he succeed in finding the whereabouts of the maker at all. At last he was directed to the quaint street in the quarter of the city of Zurich, known as the "Trittligasse" (the street of the little steps). There he found a gate in a wall bearing the desired number, but no name or sign of any description to indicate what was within. Knocking to obtain admission, he was finally let into a garden, over another wall and up a picturesque set of steps and ushered into a little room, in which was work of the finest description. A few men and boys, a couple of women—this was the working force; but here were products which surpassed the finest instruments of any he had ever seen. Each article was shown and handled as if it had been a personal pet, hardly to be parted with; and it was, indeed, interesting to see how every instrument was calibred and tested and recorded in a manner which could not but prove that for such work individualism had its advantages over collectivism. The articles were indeed "manufactured" in true etymological sense of the term "hand made," and head made, too, for that matter; and all this in a little outbuilding, accessible only after diligent search and many misadventures.



**V** Means everything that is first quality in Watch Glasses.

**T** They are used by more Watch and case makers than all others.

**F** Their success has induced others to copy the label but not the quality.

## PAILLARD = = WATCHES NON=MAGNETIC

ARE AS GOOD AS THE **BEST.**

R. A. LOVELAND, IMPORTER, 177 Broadway, New York.



## SOLID GOLD CASES

ARE ALL STAMPED WITH THIS TRADE MARK AND WARRANTED BY

THE ROY WATCH CASE CO.

CAMPBELL-METOALF SILVER CO.,  
SILVERSMITHS,



ALL GOODS 925/1000 FINE.  
Factory, Providence, R. I. Offices, New York and San Francisco.

H. M. RICH & CO.,  
Jewelry - Auctioneers,  
21 School Street,  
BOSTON, MASS.

# CARBORUNDUM

THE GREATEST ABRASIVE YET DISCOVERED.

Four times the Labor and Expense-saving qualities of Emery, Corundum or other abrasives. Adapted for Lapidary Work, Grinding, Polishing and every operation where a perfect abrasive is necessary.

Hones, Slabs, Files.

## Price List of Carborundum Wheels.

ACHESON'S PATENT, February 28th, 1893; February 26th, 1895.

DIAM. IN.	THICKNESS IN INCHES.															MAX. REV.	
	¼	⅜	½	⅝	¾	1	1¼	1½	1¾	2	2¼	2½	2¾	3	3½		4
1	\$.15	\$.15	\$.20	\$.20	\$.20	\$.25	\$.30	\$.30	\$.35	\$.40	\$.40	\$.45	\$.50	\$.50	\$.60	\$.70	18000
1½	.20	.25	.25	.25	.30	.30	.35	.40	.40	.45	.50	.55	.55	.60	.70	.75	14000
2	.20	.30	.30	.30	.35	.40	.45	.50	.55	.60	.65	.70	.75	.85	.90	11000	
2½	.25	.35	.40	.45	.50	.55	.65	.70	.80	.90	1.00	1.10	1.20	1.25	1.40	8800	
3	.30	.45	.55	.60	.65	.75	.85	1.00	1.15	1.25	1.40	1.50	1.60	1.75	2.00	7400	
3½	.40	.50	.65	.70	.80	1.00	1.15	1.30	1.45	1.65	1.80	1.95	2.10	2.20	2.55	6300	
4	.50	.60	.75	.85	1.00	1.20	1.40	1.60	1.80	2.00	2.20	2.40	2.60	2.80	3.20	5500	
5	.70	.85	.95	1.15	1.25	1.60	1.95	2.30	2.65	3.00	3.30	3.65	3.95	4.25	4.90	4400	
6	.95	1.10	1.30	1.55	1.75	2.20	2.70	3.15	3.60	4.10	4.55	5.00	5.45	5.90	6.80	3700	
7	1.25	1.45	1.65	1.95	2.30	2.95	3.50	4.15	4.80	5.40	6.00	6.60	7.20	7.80	9.00	3160	
8	1.50	1.70	2.00	2.40	2.80	3.60	4.40	5.20	6.00	6.75	7.55	8.30	9.10	9.90	11.45	2770	
9	1.80	2.10	2.40	2.90	3.35	4.30	5.30	6.25	7.25	8.20	9.15	10.10	11.10	12.05	14.00	2460	
10	2.15	2.50	2.85	3.45	4.00	5.15	6.30	7.45	8.60	9.75	10.90	12.00	13.20	14.35	16.60	2210	
12	2.65	3.10	3.70	4.50	5.25	6.80	8.40	9.95	11.50	13.05	14.60	16.20	17.75	19.30	22.45	1850	
14			5.05	6.05	7.00	9.00	11.00	13.00	15.00	16.95	18.95	20.95	22.95	24.90	28.90	1580	
16					9.10	11.70	14.30	16.85	19.95	22.00	24.55	27.15	29.70	32.30	37.40	1380	
18					11.25	14.45	17.70	21.00	24.25	27.50	30.75	34.00	37.25	40.50	47.00	1230	
20						17.50	21.55	25.55	29.60	33.70	37.80	41.90	45.95	50.00	58.00	1100	

CUT THIS OUT.

The wheels are made with a vitrified bond and pressed under hydraulic pressure. Those over three inches in diameter are turned up after firing. The same numbers are used to designate the degrees of fineness, as are used with Emery, and the wheels are made in seven degrees of hardness, marked SSS, SS, S, M, H, HH, HHH, from extremely soft to extremely hard. In ordering, state diameter, thickness, hole, number and hardness.

## THE CARBORUNDUM CO.

WORKS: MONONGAHELA, PA., AND NIAGARA FALLS, N. Y.

### THE SWAN FOUNTAIN PEN

Reputation World Wide.  
Made upon Distinct Principles.  
Is a Compressed Air Pump.  
Simply Wet the Insides to Provoke  
an Energy.

W. W. Stewart, Inventor and Patentee.

A variety of Styles and Prices

- 3 Sizes Safety Swans.
- 3 Sizes Self-filling Swans.
- 3 Sizes Adjustable Feed Swans.

MABIE, TODD & BARD,

NEW YORK AND LONDON.

## AMERICAN WATCH TOOL CO.

ESTABLISHED 1872.  
INCORPORATED 1894.

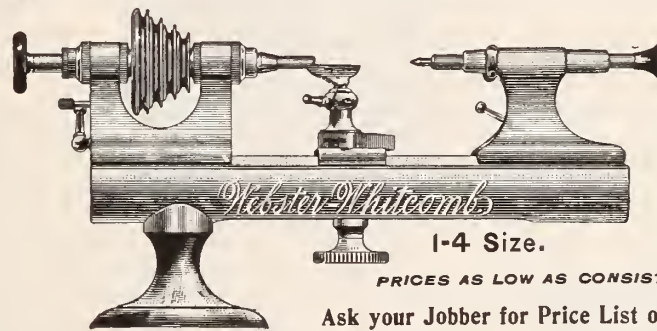

THE  
**Webster-Whitcomb**

GROWS IN POPULARITY

PRICES AS LOW AS CONSISTENT WITH QUALITY.

Ask your Jobber for Price List of 1895, or write to us at

Stoney-Batter Works, Chymistry Dist., Waltham, Mass.

### AIKIN, LAMBERT & CO.,

MANUFACTURERS OF

FINE GOLD PENS, HOLDERS, PENCILS,  
TOOTH PICKS, and NOVELTIES.

PAUL E. WIRT FOUNTAIN PENS, at new and lower prices . . .  
MERCANTILE FOUNTAIN PENS, guaranteed to give satisfaction.

Catalogues with terms and discounts furnished to the trade.

BRANCH, 103 STATE STREET, - - - CHICAGO.

19 MAIDEN LANE, NEW YORK.

### AIKIN-LAMBERT JEWELRY CO.,

IMPORTERS OF

**DIAMONDS.**

JOBBERS IN

WATCHES, JEWELRY, CHAINS  
NOVELTIES, ETC.

LATEST DESIGNS.

LOWEST PRICES

**CYCLING PROGRESS  
EXEMPLIFIED.**

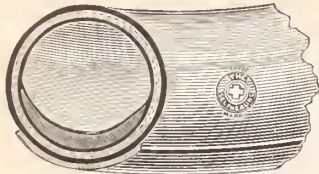

**THE WONDERFUL  
SELF-HEALING TIRES**

are single tube, finest rubber, finest wove Sea Island cotton fibre, re-enforced inside and outside on tread, and no better tire can possibly be made. They are fully guaranteed against all climatic changes, are the most resilient ever made, and when punctured instantly heal the wound of their own volition.

THEY WEIGH NO MORE THAN OTHERS,  
COST NO MORE,  
AND ARE WORTH TEN TIMES MORE.

—SEND FOR TIRE BOOKLET—

**Wm. H. CAHN, GENERAL MANAGER,**  
48 and 50 Maiden Lane, New York.

BY EVERY TEST THEY ARE THE BEST.  
THE UNIVERSAL FAVORITES.



**SUPERB  
Olympic  
BICYCLES**

For sale by more than 2,000  
Jewelers, and constructed to meet  
the demand for finest quality  
For Adults and Juveniles.

SEND FOR EXQUISITE  
CATALOGUE.

Top Grade "Olympics" have SELF-  
HEALING TIRES.

Olympic Cycle Mfg. Co.,  
N. Y. Office: 35 LIBERTY STREET

General Jobbing Ag'ts, S. F. MYERS & CO.,  
WHOLESALE JEWELERS, Myer's Building New York.

**RECEIVER'S SALE!**

**TRADE OPPORTUNITY.**

Entire Stock of

**CHAS. JACQUES CLOCK CO.,**

22 Cortlandt St., New York,

**...Must Be Closed Out...**

Latest Paris Novelties,  
all New Importations  
of this Spring

Together with LARGE STOCK of

**ELLIOT CHIME CLOCKS,**

And a Fine Line of Other

**HALL CLOCKS.**

By order of

**ALBERT C. WALL, Esq.,**  
Receiver.

**BAWO & DOTTER,**

26-32 BARCLAY ST.

NEW YORK.

P. O. Box 1872.



NO LARGER STOCK

OF

**HALL  
CLOCKS**

IS SHOWN IN  
THIS CITY.

Large Stock  
OF  
MOVEMENTS.

NEW DESIGNS  
IN CASES.

**STERLING**

Sheet and Wire Supplied. All Sizes.

**J. SCHAWEL & CO.,**

Gold, Silver and Platinum Refiners.

29 JOHN STREET, NEW YORK.

**SLOAN & COMPANY,**

SUCCEEDING

JOHN A. RILEY & SLOAN CO.,

**MANUFACTURING JEWELERS,**

23 MAIDEN LANE, N. Y.

HAYS BUILDING.

AUGUSTUS K. SLOAN, Pres.  
FRANK T. SLOAN, Vice-Pres.

BENNET OSBORN, JR., Treas.  
ALLAN A. McDONALD, Sec'y.



**34 YEARS OF  
HONEST RETURNS**

IS OUR GUARANTEE OF SATISFACTION  
TO ALL OUR CUSTOMERS.

WE DO OUR OWN SMELTING,

**JOHN AUSTIN & SON,**

ASSAYERS, REFINERS AND SMELTERS,

74 & 76 Clifford St., Providence, R. I.

**SECURITY PIN GUARD**

PAT'D DEC. 25, 1894  
MANFD BY SECURITY MFG CO. **25¢**

7 ASTOR HOUSE (BROADWAY) N.Y.

85c. doz. Net Cash Discount to Jobbers

**THIS TRADE MARK....**



on cut glass is a guarantee of superior  
quality. Designs all new and original.  
Libby blanks used exclusively. Send  
for catalogue.

STANDARD CUT GLASS CO.,  
545-547-549 W. 22d St., New York.

**QUICK SELLERS.....**

IN STERLING SILVER  
ARE MADE BY

**CODDING BROS. & HEILBORN,**

North Attleboro, Mass.

**DUBOIS WATCH CASE CO.**

TRADE MARK



REGISTERED.

FINE HAND MADE  
**SOLID GOLD CASES.**

A PRIDE TO THE MAKER,  
DEALER & WEARER.

**JACOT & SON,**

Importers and Manufacturers of

**Musical Boxes,**

39 Union Square. New York.

**X RAYS**

are not needed to see the Xtraordinary merit of the Royal Clusters. The most Xacting Xaminer can find no fault with the Royal Cluster. It is Xactly what your customer has wanted for years. It is a mounting of Xceptional merit, finished with Xtreme care and Xactness.

**HENRY E. OPPENHEIMER & CO., 14 MAIDEN LANE, NEW YORK.**

**DIAMONDS** Importers and Cutters. **L. & M. KAHN & CO.,** 172 Broadway, New York. **DIAMONDS**





Copyright by THE JEWELERS' CIRCULAR PUB. CO.

189 Broadway, New York.

Entered at the Post Office in N. Y. as second-class matter

VOL. XXXII.

NEW YORK, WEDNESDAY, JUNE 24, 1896.

NO. 21.

## THE GENESIS AND ARTISTIC DEVELOPMENT OF THE LOVING CUP

Copyright, 1896, by THE JEWELERS' CIRCULAR PUB. CO.

## PART II.

THERE cannot be a doubt that in the earliest period of human society, man would soon feel the necessity of possessing vessels capable of receiving and containing any liquids he might desire for food, drink or occasional refreshment. Mention is very early made of the employment of skins of animals for bottles and vessels. It is reasonable to believe that what we call pottery was an immediate successor to vessels made of skins, there being very ancient records of the employment of such articles. There are no certain proofs by which to determine the era of the invention of pottery. What is known, however, is that articles of pottery were anciently used for purposes approaching those of the loving cup of to-day, and in this connection it is interesting to note that the Portuguese word for cup is *porcellana*.

There seems to be no remains of the ancient Egyptians, Assyrians, Babelonians and Persians that would lead one to infer that these people

ramis, but as Mr. Miles observes, this name was probably used in the same sense in which we call the obelisk in Central Park, "Cleopatra's Needle," for such an enormous piece of plate could not possibly be put to any prac-

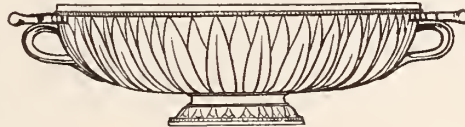

GREEK KYLIX.

tical purpose. The Assyrians and Babelonians were fond of immoderate drinking, but according to the sculptures, the banqueting contained no passage of a cup from one guest to another. In the Assyrian sculptures, the attendants are seen to dip the wine cups into a huge bowl or vase which stands on the ground and reaches as high as a man's chest, and carry them full of liquor to the guests. Each guest holds a cup in his right hand. The first mention of cups employed in the manner of the loving cup of to-day is of the Greek kylixes, which Dr. Birch in his "History of Pottery" says, held about a "pint, or even from 4 to 7 heminai, and were probably passed around from guest to guest." The *Kylix* was the most famous of the Greek cups. It was so called from being turned on a lathe. It was generally a flat, shallow and extremely wide saucer, with two handles, and a tall stem or foot, and was decorated with red figures of the finest style, both on the exterior and interior. Those of the earliest period are distinguished by their deeper bowl and taller stem, while the bowl of those of a later period, with black figures, is unprovided with a foot. Others ornamented with paintings of a strong and fine style have a shallow bowl, recurved handles rising rather higher than the lip, and a

stem not so high as the earlier kylixes. Their shape is one of the most elegant of the cup handed down from antiquity. In banqueting scenes depicted upon them they are often represented as being twirled around upon the finger in the supposed Sicilian game of *kotabos*. These cups, usually of clay, were made often in fine wood or glass and gilded. The cup from the tomb of Koul-Oba, of Scythia (fourth century, B. C.) illustrated here, is of silver and in the form of the kylix of the Greeks. There were two of these found, absolutely alike and having the peculiarity of a loose disk fitting into the bottom of the interior. In the shape of the cup, which is perfectly plain, there is a simple beauty which was always so strongly developed in the work of the Greek artists. The article is thought to have been used as a drinking cup, and that when required the disk was placed in the interior, converting it into a vessel for pouring out li-



CUP FROM THE TOMB OF KOUL-ObA;

had any custom approaching that embodied in the use of the loving cup. They had drinking cups, which were very highly prized, but they seem to have been designed for use by one person only. Pliny speaks of an Assyrian bowl weighing 15 Attic talents (about \$18,000.) This was called the drinking bowl of Semi-



GREEK KANTHARUS.

bations to Apollo. If this is a true kylix, it is the earliest known true predecessor of the loving cup.

There were other Greek cups which from their size and shape, it is reasonable to infer were used by more than one person, thereby possessing the essential element of a loving cup.

# KENT & STANLEY CO., LTD.,

JEWELERS AND SILVERSMITHS,

SEAMLESS GOLD FILLED CHAINS, JEWELRY,  
SILVER NOVELTIES.

NEW YORK OFFICE,  
21 and 23 Maiden Lane.



BOSTON OFFICE,  
403 Washington Street,

FACTORY, PROVIDENCE, R. I.

## NEW DESIGNS IN ALL LINES.

ALL OUR SILVER GOODS ARE GUARANTEED 925-1000 FINE.

# AJAX INSULATORS.

PATENTED OCTOBER 28, 1889.

THEY are Cheap; THEY Reduce Wear and Tear of the Case;  
THEY Protect from all Ordinary Magnetic Influences.

Perfect in  
Action.  
Convenient  
in Use.



Educate  
Your Customers  
by Talking  
up  
Ajax Watch  
Insulators.

MADE IN ALL SIZES, OPEN FACE AND HUNTING.  
FOR SALE BY JOBBERS.

MANUFACTURED BY

## The Newark Watch Case Material Co.

19 WARD STREET, NEWARK, N. J.

## The Bonner Combination

RING, STUD and SCARF PIN.  
A Long Screw and a Round Bezel.

Send for Selection Package

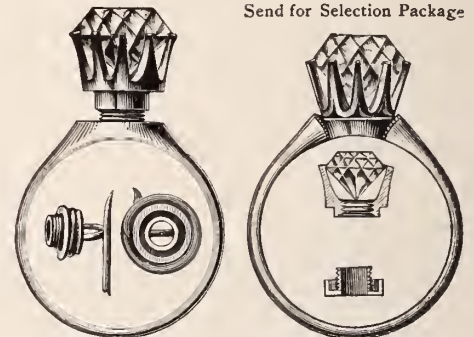

BONNER, RICH & CO.,

41 & 43 Maiden Lane, NEW YORK,  
604 Champlain Building, CHICAGO.

## CROUCH & FITZGERALD.

Jewelry Trunks  
and Cases,

161

Broadway,  
Bet. Cortlandt and  
Liberty Sts.,  
688 B'way,  
701 6th Ave.,  
NEW YORK.



# Buy "The Best"

## THE "Dueber Special" BICYCLE.

MAYSVILLE, KY., April 24, 1896

Dueber Watch Case Mfg. Co., Canton, O.

Dear Sirs: The wheel came all right, and in fact exceeds my expectations. I have ridden the different high grade wheels for twenty years, and find this the easiest running wheel I have ever been on. Yours,

JOHN BALLENGER

CHICAGO, ILL., April 23, 1896.

Dueber Watch Works, Canton, O.

Gentlemen: After a careful and critical examination of the "Dueber Special" Bicycle, I have no hesitancy in recommending it as a first-class wheel in every respect and I consider it the best wheel I have ever seen. The extreme care bestowed upon the fitting and finish of all parts, will alone recommend it to the watch making fraternity, who as a rule, are critical in these respects. The "Dueber Special" ranks with, if it does not surpass the highest grade wheels on the market. I see no reason why it should not have an enormous sale.

Very respectfully,

GEO. K. HAZLITT.

## NEW ORNAMENTS

... IN ...

## STERLING SILVER.



Many Designs in

Galleries, Belt Buckles,  
Belt Slides **AND** Belt Fastenings,

ALWAYS SOMETHING NEW.

THOMAS W. LIND,

Manufacturer, of

JEWELERS' FINDINGS.

67 Friendship Street,

PROVIDENCE, R. I.



# Standard Sterling Silver Goods.

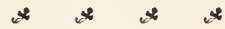

## Belts,

LEATHER, GILT,  
SILVER AND  
SILK WEBBING.

## Waist Sets,

Sleeve Links,  
Hat Pins,

IN

Sterling Silver

AND

Rolled Gold Plate.

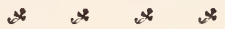

600 Useful Articles

IN

Sterling Silver.



REGISTERED.

## Foster & Bailey,

Providence, R. I.

NEW YORK,  
SAMPLES ONLY.

CHICAGO,  
SAMPLES ONLY.

Among these was the *Kalos* or cask, a name given according to Kallimachos, to all pottery that was used at banquets. It appears also to have been employed as a *situla*, or bucket, and it is possible that the deep semi-oval vase of pale

The *Kothon* almost seems to have been a Lacedaemonian name for a military cup used for drinking water, and adapted by its curved mouth to strain off the mud. A specimen illustrated in the group approaches greatly the two handed loving cup of to-day. Many examples of the *rhyton* occur. The great peculiarity of this cup was that it could not be set down without drinking the contents. It may be divided into two shapes: first a cylindrical cup terminating in the head of an animal, and with a flat banded handle, the lip slightly expanding. In the second kind the body is fluted, longer, and more horn-like, and terminates in the head or forepart of an animal, which is pierced so as to let a jet of fluid flow out. These vessels sometimes have a small circular handle at the side to suspend them to the wall. Many of them are entirely of terra-cotta. They were first mentioned by Demosthenes, and it appears from Polybios that there were several statues of *Klino*, the cup bearer of Ptolemy Philadelphus, holding a *rhyton* in his hand. The *rhyton* has been reproduced in modern form as a loving cup by silversmiths, a notable example being the Gerry cup, of the New York Yacht Club, won by *Wasp*, made by the Whiting Mfg. Co., New York. One side of this modern *rhyton* is presented in this article.

The productions of the potter never perhaps attained greater excellence as to form than in the drinking cup. If any specimens of fictile ware represent the shapes mentioned

by Homer, who in the true poetic spirit always speaks of cups as made of precious metals, they must be looked for in the primitive vases of Melos and Athens. The great cup described by Homer seems to be very near the loving cup in its character and uses. "The great cup, ornamented with golden studs, was produced, which the old man had brought from home. It had four handles, and two golden doves were placed on each, and it had two stems. When full, anyone else could hardly lift it from the table, but



GREEK RHYTONS.

varnish and generally with figures of a late style either embossed or painted, was the *kados*. In the "Eirene" of Aristophanes, Trygaios persuades a helmet-seller to clap two handles on a helmet and convert it into a *kados*. From this it is to be inferred that the *kados* was no small article, that it held more liquid than one could drink and that its two handles facilitated its passing from one guest to another.

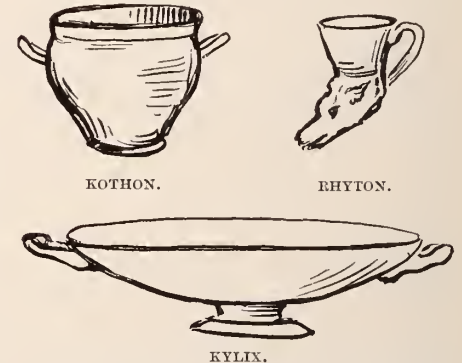

KOTHON.

RHYTON.

KYLIX.

CONVENTIONAL FORMS OF ANCIENT GREEK DRINKING CUPS.

old Nestor with ease." The cups mentioned by Homer are the *depos*; the *aleison*, a cup with two handles; the *kissybion*, so called from its being made of ivy

**DORFLINGER'S**

**AMERICAN**

**CUT GLASS.**

915 BROADWAY  
36 MURRAY ST.  
NEW YORK.

TRADE  
  
MARK.

**W**  
**A**  
**T**  
**C**  
**H**

GOLD FILLED.

*Fabry's* 14K  
**MONARCH**

**C**  
**A**  
**S**  
**E**  
**S**

FINE CASES . . . . .

for Jewelry, Silverware, etc.  
Hardwood Chests, Trays and  
sample cases. Business estab-  
lished in 1876.

Samuel C. Jackson's Son, 180 B'way, N. Y.

**AMERICAN WATCH CASE CO.,**  
11 JOHN STREET, NEW YORK.

Manufacturers of **FINE SOLID GOLD CASES.**

Sold DIRECT to  
the RETAIL TRADE only.

**A.W.C.CO**

**A. J. COMRIE,**  
AUCTIONEER,  
22 John St., N. Y.

SPECIAL SALESMAN OF WATCHES, DIAMONDS,  
BRIC-A-BRAC, FOR ESTABLISHED JEWELERS.  
WRITE FOR PARTICULARS

**PATEK, PHILIPPE & CO.,** GENEVA, SWITZERLAND.  
MAKERS IN THE HIGHEST QUALITY OF

Fine, Plain, Complicated  
And Decorated Watches  
IN 15 DIFFERENT SIZES.

INTERCHANGEABLE PARTS.

NEW YORK OFFICE, 68 NASSAU ST. ALFRED G. STEIN, Representative.

**QUICK SELLERS.....**  
IN STERLING SILVER  
ARE MADE BY

**CODDING BROS. & HELLBORN,**  
North Attleboro, Mass.

**THIS TRADE MARK....**

 on cut glass is a guarantee of superior quality. Designs all new and original. Libbey blanks used exclusively. Send for catalogue.

**STANDARD CUT GLASS CO.,**  
545-547-549 W. 22d St., New York.

# TWO NEW PIECES FOR

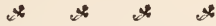

Where would we be if in a quiet season we decided to make **nothing new** till we saw a **demand**?

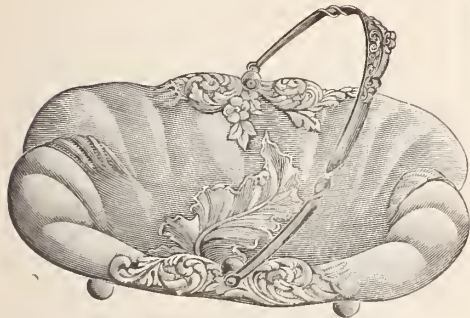

No. 6607. BON-BON DISH.

FACTORIES,  
NEW BEDFORD, MASS.



No. 2846. HAND MIRROR.

# EVERY DAY IN THE YEAR.

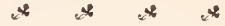

Make the **demand**. Sort up your stock with 25, 50 or 100 new pieces that will make people buy. We furnish goods that sell.

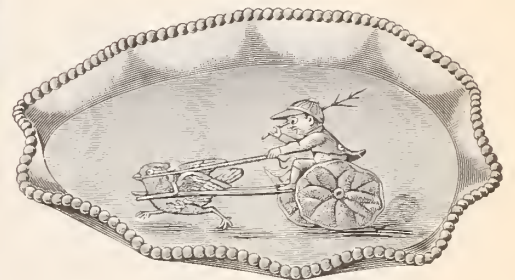

No. 1969. TRINKET TRAY.

SALESROOMS,  
NEW YORK. CHICAGO.  
SAN FRANCISCO. MONTREAL.

## PAIRPOINT MFG. COMPANY.

# CARBORUNDUM

THE GREATEST ABRASIVE YET DISCOVERED.

Four times the Labor and Expense-saving qualities of Emery, Corundum or other abrasives. Adapted for Lapidary Work, Grinding, Polishing and every operation where a perfect abrasive is necessary.

### Price List of Carborundum Wheels.

ACHESON'S PATENT, February 28th, 1893; February 26th, 1895.

DIAM. IN.	THICKNESS IN INCHES.																MAX. REV.
	1/4	3/8	1/2	5/8	3/4	1	1 1/4	1 1/2	1 3/4	2	2 1/4	2 1/2	2 3/4	3	3 1/2	4	
1	\$.15	\$.15	\$.20	\$.20	\$.20	\$.25	\$.30	\$.30	\$.35	\$.47	\$.40	\$.45	\$.50	\$.50	\$.60	\$.70	18000
1 1/2	.20	.25	.25	.25	.30	.30	.35	.40	.40	.45	.50	.55	.55	.60	.70	.75	14000
2	.20	.30	.30	.30	.35	.40	.45	.50	.55	.60	.60	.65	.70	.75	.85	.90	11000
2 1/2	.25	.35	.40	.45	.50	.55	.65	.70	.80	.90	1.00	1.10	1.20	1.25	1.40	1.50	8800
3	.30	.45	.55	.60	.65	.75	.85	1.00	1.15	1.25	1.40	1.50	1.60	1.75	2.00	2.20	7400
3 1/2	.40	.50	.65	.70	.80	1.00	1.15	1.30	1.45	1.65	1.80	1.95	2.10	2.20	2.55	2.90	6300
4	.50	.60	.75	.85	1.00	1.20	1.40	1.60	1.80	2.00	2.20	2.40	2.60	2.80	3.20	3.60	5500
5	.70	.85	.95	1.15	1.25	1.60	1.95	2.30	2.60	3.00	3.30	3.65	3.95	4.25	4.90	5.55	4400
6	.95	1.10	1.30	1.55	1.75	2.20	2.70	3.15	3.60	4.10	4.55	5.00	5.45	5.90	6.80	7.70	3700
7	1.25	1.45	1.65	1.95	2.30	2.95	3.50	4.15	4.80	5.40	6.00	6.60	7.20	7.80	9.00	10.25	3160
8	1.50	1.70	2.00	2.40	2.80	3.60	4.40	5.20	6.00	6.75	7.55	8.30	9.10	9.90	11.45	13.00	2770
9	1.80	2.10	2.40	2.90	3.35	4.30	5.30	6.25	7.25	8.20	9.15	10.10	11.10	12.05	14.00	15.90	2460
10	2.15	2.50	2.85	3.45	4.00	5.15	6.30	7.45	8.60	9.75	10.90	12.00	13.20	14.35	16.60	18.90	2210
12	2.65	3.10	3.70	4.50	5.25	6.80	8.40	9.95	11.50	13.05	14.60	16.20	17.75	19.30	22.45	25.50	1850
14			5.05	6.05	7.00	9.00	11.00	13.00	15.00	16.95	18.95	20.95	22.95	24.90	28.90	32.80	1580
16					9.10	11.70	14.30	16.85	19.95	22.00	24.55	27.15	29.70	32.30	37.40	42.50	1380
18					11.25	14.45	17.70	21.00	24.25	27.50	30.75	34.00	37.25	40.50	47.00	53.50	1230
20						17.50	21.55	25.55	29.60	33.70	37.80	41.90	45.95	50.00	58.00	66.00	1100

The wheels are made with a vitrified bond and pressed under hydraulic pressure. Those over three inches in diameter are turned up after firing. The same numbers are used to designate the degrees of fineness, as are used with Emery, and the wheels are made in seven degrees of hardness, marked SSS, SS, S, M, H, HH, HHH, from extremely soft to extremely hard. In ordering, state diameter, thickness, hole, number and hardness.

Hones, Slabs, Files.

CUT THIS OUT.

## THE CARBORUNDUM CO.

WORKS: MONONGAHELA, PA., AND NIAGARA FALLS, N. Y.

wood, or from its being ornamented with carvings representing the foliage of ivy; the *kypellon*, or later *kymbion*, which among the Kretons and Kryprians had either two or four handles; and the *amphikypellon*, having two handles, one at each side. The *karchesion* was used by Dionysos and his "wassail rout." It had two handles. The Athenians had 72 kinds of cups.

Drinking vases were also formed from large horns of the Molossian and Pæonian oxen, rimmed with silver or gold, some having lids of precious metal. Some authorities trace the loving cup to the *kantharos* of the Greeks, and in fact the specimen depicted



THE GERRY CUP (NEW YORK YACHT CLUB.)—A GREEK RHYTON.

on page 4 shows great similarity to the later day article. The *kantharos* had high loop handles at the side, and was a drinking cup, being sacred to Bacchus. The cup illustrated was decorated on the neck and lower body with goat's skin, while the main portion of the cup bore the thyrsus in pairs, alternating with scenic masks and other ornaments, all in bold relief.

As another evidence of the antiquity of vessels with a multiplicity of handles, there was the *seleukis*, named after King Seleukos. Its shape has been recognized in some of the paintings of Pompeii. It appears to have had four handles. Again there was the *hybria* or water vase, known from the word *ΗΥΒΡΙΑ* inscribed over a vase of this shape which Polyxene has let fall in going out of Troy to draw water from the fountain. The two small side handles are cylindrical, the large ones are riband-like or moulded. The vessel thus has four handles.

Surrentum, upon the eastern coast of the Bay of Naples, was renowned for drinking cups. There were potteries here in the time of Pliny, celebrated for producing excellent cups.

(To be continued.)

## TARIFF DECISIONS AND CUSTOMS RULINGS.

Reported from Washington expressly to the Jewelers' Circular.

### The Classification of Certain Knives and Forks.

Decisions at once favorable and adverse have been rendered by the Board in the case of an appeal entered by Baerach & Freedman, New York, relative to the rate and amount of duty collectable on certain merchandise imported by them through the port of New York, on Sept.

cent.; but the Collector's decision on the forks was sustained.

### The Classification of Field Glasses.

On Sept. 14, 1885, J. W. Hampton, Jr. & Co. imported per *Etruria*, certain goods which were classified by the Collector of the Port of New York as "optical instruments" and as such they were assessed at 40 per centum ad valorem under paragraph 98 of the act of Aug. 28, 1894. The goods in question were field glasses with aluminium frames and the importers claimed that they should have been properly classified under paragraphs 102 or 177 at 35 per centum ad valorem. In their appeal, made to the General Appraisers, they refer to a previous appraisal rendered by the Board, 927, in which a similar article was held to be dutiable under the act of 1890 as a manufacture of glass. The appraisers, in reply, draw attention to the fact that in the act of 1890 there was no special provision made for "opera glasses and other optical instruments," as done by Congress in the Act of 1894, where they have characterized opera glasses as optical instruments. It was the opinion of the Board that field glasses were properly classified as "optical instruments," and the assessment of duty by the Collector was affirmed.

### The Late Augustus S. Chase.

WATERBURY, Conn., June 11.—The late Augustus S. Chase, of this city, announcement of whose death and a summary of whose business connections were given in last week's CIRCULAR, had not been perfectly well for several years, but much benefit to him from his European trip was expected and he had improved at first, only to succumb at last to fatal heart weakness. At Madrid, Spain, he began to decline in strength. In addition to the long list of prominent corporations of which he was either president or a director or both, given in last week's CIRCULAR, he was a trustee, with Hon. E. C. Lewis, of the Brown & Bros. estate, trustee of the Waterbury Savings bank, member of the board of agents of the Bronson library, treasurer of the water board sinking fund for the city of Waterbury, treasurer of St. Margaret's school, one of the original incorporators and vice-president of the Waterbury Hospital, member of the prudential committee of the Waterbury Industrial School, member of the advisory committee of the Young Women's Friendly League, administrator of the estate of Charles Benedict with Gillman C. Hill, administrator of the estate of Erastus L. DeForest with Leman W. Cutter. He was, too, executor, administrator and trustee of many other estates and trust funds.

25, 1895. The merchandise consisted of knives and forks, about six inches in length, having decorated green china handles and silver blades, while the prongs were gilded. The goods were valued at \$23.34 per dozen pairs and were assessed for duty by the Collector of the port at 45 per centum ad valorem under the provisions of paragraph 140 of the Act of Aug. 28, 1894 as "Table and carving knives and forks, valued at more than \$4 per dozen pieces, 40 per centum ad valorem," and the appellants claimed that they should have been classified under a further provision of the same paragraph at 35 per centum ad valorem, namely: "All other table knives and forks, x x x x and all fruit knives, thirty-five per centum ad valorem." The Board made the following findings: (1) That the goods are table knives and forks, and as such are valued at more than \$4 per dozen; (2) that the knives are fruit knives, and as such they would be more properly classified for duty at 35 per centum ad valorem, and in this particular the claim of the appellants is affirmed, namely that 35 per cent. shall be claimed on merchandise to the value of \$47.15 less discount of 22½ per

# A JEWELER'S NECESSITY



— IS THE —

## “TRADE-MARKS OF THE JEWELRY AND KINDRED TRADES.”

Copyright, 1896, by The Jewelers' Circular Pub. Co., 189 Broadway, New York.

For seven months THE JEWELERS' CIRCULAR has had under way a work that will comprise the trade-marks of every branch of the Jewelry, Watch, Clock, Silverware, Silver Plated Ware, Optical Goods, Precious Stone, Art Pottery, Bric-à-brac, Cut Glass and cognate lines of the Jewelry Industry.



The work is now nearing completion. We consider it will be the most valuable book that has ever been issued to the Jewelry trade.

It is a work which the retailer and wholesaler will immediately appreciate.

It will be a book of constant reference, and will be consulted more perhaps than any other book issued to the trade.

It will be a book of daily use.

It will be sold at a figure that will guarantee its rapid distribution.

In addition to illustrations of the various trade-marks and the names and the addresses of the firms to whom they belong, and the class of goods to which they appertain, the work will contain other interesting and valuable information bearing upon the subject of trade-marks.



Those firms who have as yet not sent electrotype, print or drawing of their trade-mark or trade-marks are requested to do so at the earliest possible moment.

Members of the Trade, Manufacturers, Wholesalers and Retailers should at once place their orders for

### “TRADE-MARKS OF THE JEWELRY AND KINDRED TRADES.”

\$1 per copy. Bound in Cloth. Payable now or upon delivery of Book. Detach order below and forward to the Jewelers' Circular Publishing Co., 189 Broadway, New York.



#### ADVANCE ORDER BLANK.

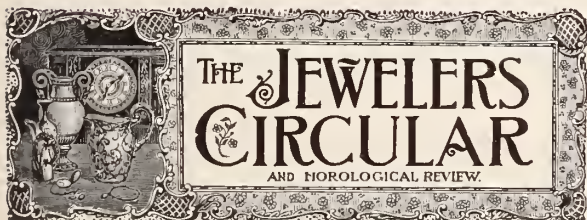

189 Broadway, New York.

..... 1896

Please file this order for ..... copy of

“Trade-Marks of the Jewelry and Kindred Trades”

for which I agree to pay \$1.00 per copy, postage prepaid, upon delivery of book.

Name.....

Street..... City..... State.....

**DIAMONDS.**  
**Wm. S. Hedges & Co.,**  
 IMPORTERS OF  
**Diamonds and Precious Stones.**  
**DIAMOND JEWELRY.**  
**170 Broadway, New York.**  
 22 Holborn Viaduct, London.

**Alfred H. Smith & Co.,**

IMPORTERS

**DIAMONDS**

AND

PRECIOUS STONES,

**182 BROADWAY, COR. JOHN STREET,**

**NEW YORK.**

Venetian Building, **34 & 36 Washington St.**

**CHICAGO, ILL.**

**BATES & BACON**  
**"FAVORITE"**  
 14K

**ALWAYS**

Ask to see  
 our

**BATES & BACON**  
**"ROYAL"**  
 14K

**GOLD FILLED**  
**WATCH CASES.**

**BATES & BACON**  
**"PURITAN"**  
 14K

**None Better**  
 and  
**Few Equal.**

**HERMAN KOHLBUSCH, SR.**

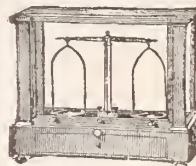

Established 1859  
 Manufacturer of  
**FIN E BALANCES**  
**AND WEIGHTS** for  
 every purpose  
 where accuracy is  
 required. 59 Nassau  
 Street, cor.  
 Malden La. N. Y.



Repairs (any make)  
 promptly made.

**SCHULZ & RUDOLPH,**  
 IMPORTERS AND CUTTERS OF  
**DIAMONDS AND OTHER PRECIOUS STONES,**

(Successors to JOHN E. HYDE'S SONS.)

Sole Agents for **The Celebrated Jules Jurgensen Watches.**

**28 JOHN ST. and 65 NASSAU ST., NEW YORK.**

**The Bowden Rings**

ARE COMPLETE IN VARIETY, CORRECT  
 IN QUALITY AND PERFECT IN FINISH.  
 WE MAKE EVERY VARIETY OF FINGER  
 RINGS

**J. B. BOWDEN & Co.,**

**3 MAIDEN LANE,**

**NEW YORK.**

BRANCH OFFICE :

206 KEARNY STREET  
 SAN FRANCISCO, CA

**The Store of R. Michaels & Co. Closed Under Mortgage.**

KANSAS CITY, Mo., June 18.—The store of R. Michaels & Co., 925 Main St., was closed Tuesday under a chattel mortgage given to Emil Pollack, trustee, by Rose Michaels and Abraham Michaels, proprietors. The mortgage was for \$3,500, of which \$2,000 was due to the National Bank of Commerce, \$500 to Nathan Speer, Kansas City, and \$1,000 to Aaron J. Michaels, Brooklyn. Later a second mortgage appeared subject to the first, of which \$250 was due the Meyer Jewelry Co.; \$130 to Herman Oppenheimer, and \$82 to J. A. Norton & Son, all of this city. A third chattel mortgage for \$5,090 secured all New York creditors.

The assets are not yet known, but it is doubted if they will equal the liabilities. An auction was recently held which reduced the stock. Joseph Michaels opened here in business in 1883 and Abraham was admitted in 1885.

**The E. N. Welch Mfg. Co. Reorganized.**

HARTFORD, Conn., June 18.—The E. N. Welch Mfg. Co. plant at Forestville may soon resume clock manufacturing, the concern having been reorganized with \$300,000 capital.

The old company reduced their capital stock from a half million dollars to \$100,000, and it was reported that the stockholders would put \$200,000 new stock on the market, and that when \$100,000 was taken the reorganization would be perfected. The company have met with success in their plans, and among the subscribers are John H. Sessions, \$10,000; John H. Sessions, jr., C. S. Treadway, J. S. Deming & Co., A. Toplin, Miles L. Peck, S. R. Mitchell and Hobert Booth. The machinery in the different shops has been put in order, and when business warrants it, the plant will again be put in operation.

**The Store of James P. Slattery Attached.**

MANCHESTER, N. H., June 16.—An attachment has been placed upon the store of James P. Slattery. The liabilities are about \$12,500; the assets about \$9,912.90, consisting of stock (taken at cost) \$7,757.42, repairing material, \$100, fixtures, \$1,000, cash on hand \$100, book accounts \$655.48.

A meeting of the creditors is called at 3 o'clock P. M., Tuesday, June 23d, at the office of O'Connor & Shea, 20 Opera House block, Hanover St., this city. Creditors are requested to attend with correct statements of accounts.

H. Lichtenstein & Co. have discontinued their wholesale jewelry business in Salt Lake City, Utah.

There was a small fire in the jewelry store of Frank A. Conant, Santa Barbara, Cal., but slight damage was none.

Samuel Henderson, Springfield, S. Dak., has given a realty mortgage for \$850.

L. W. Hensell has moved his jewelry business from Snohomish to Seattle, Wash.



**Among the African Diamond Mines.**

UNSUCCESSFUL EFFORTS TO BREAK THE DE BEERS MONOPOLY—THE FAILURE OF PROMISING MINES—THE DECAY OF I. D. B.

KIMBERLEY, May 15.—Owing to the political troubles, of which you have doubtless read, there has not been such an active interest as formerly in matters affecting the diamond industry. Nevertheless the boom in new diamond mines continues, although side by side with the advent of fresh and promising concerns, many of the older and more questionable small projects are experiencing the throes of failure. The activity in the quest for new diamond mines doubtless indicates the wide desire existing here to discover something that will be a real rival to De Beers and to destroy the monopoly that colossal corporation has created in the supply of the world's diamonds. Another strong motive probably is that a new venture, which even remotely threatened competition with De Beers, would be exceedingly valuable to the owners, as they might feel assured that the company would acquire their rights at almost any kind of fancy price so as to keep up the close monopoly.

As yet, however, the De Beers company have not been forced in this manner to any great extent. They paid heavily for the Wesselton mine, but they keep its value as a producer of diamonds a secret. Robinson's diamond mine, of which so much was expected and predicted, is now almost silent, and experts are saying that it can never be classed among the few payable diamond mines, however economically it may be worked. It may be stated in this connection that the De Beers company originally held one-quarter share in the Robinson mine, and helped the endeavors made to demonstrate its payable character. In the end, however, the De Beers directors abandoned their holding at a great sacrifice, which it is presumed they would not have done had they not been absolutely certain that the course taken was a proper one.

Not quite so much is heard now of I. D. B. and it is apparent that the elaborate detective system has, temporarily at any rate, broken the back of the iniquitous traffic. Indirectly the Transvaal gold fields have helped towards this consummation by attracting a great portion of the shady population from this center. These persons, however, have not mended their ways much, and are almost as great a hindrance to the gold industry as they were to the diamond trade.

ST. GEORGE.

Liquor glasses and flask have colored stems and handles in desirable shades.

Dressing bags are coveted possessions of modern travelers; a luxurious as well as serviceable bag is made in pig skin with hand chased silver mountings. The side frames with the cut glass bottles and other fittings, can be lifted out and placed ready for use on the dressing table.

ESTABLISHED 1840.

**RANDEL, BAREMORE & BILLINGS**

IMPORTERS OF

**DIAMONDS,**

AND OTHER PRECIOUS STONES

**FINE PEARLS A SPECIALTY.**

MANUFACTURERS OF

**DIAMOND JEWELRY**

A Large Stock of Fine Mounted Goods Constantly on Hand.  
Goods Sent on Approval and Insured in Transit.

**Diamonds Cut, Recut and Repaired.**

58 Nassau Street,  
29 Maiden Lane,  
NEW YORK.

1 Tulp Straat,  
AMSTERDAM.

1 St. Andrew's St.,  
Holborn Circus,  
LONDON E. C.

ESTABLISHED 1841.



**CARTER, HASTINGS & HOWE,**

MANUFACTURERS OF

**GOLD JEWELRY,**

**15 MAIDEN LANE, NEW YORK.**

A. CARTER,

C. E. HASTINGS,  
W. T. CARTER

G. R. HOWE  
W. T. GOUGH

FACTORY, NEWARK, N. J.



**The STATIONERS' ENGRAVING CO.,**

98 TO 102 NASSAU STREET, NEW YORK.

MAKERS OF

WEDDING INVITATIONS, RECEPTION AND VISITING CARDS

of the Best Quality, which are offered to Jewelers of recognized standing only,

Trade Mark "SILVER WHITE," registered.

## Intrinsic merit

combined with low prices, makes Cahoone's line for the coming season the most attractive ever offered to the trade.



## Cahoone's rings

this year are shown in a host of beautiful designs. Particular attention is called to the Imitation Rose Diamond and Opal Combination Rings. Sold by all leading jobbers.

GEO. H. CAHOONE & CO., Kent & Stanley Building, Providence, R. I.  
N. Y. OFFICE, 21 MAIDEN LANE.

## Summer Fashions in Jewelry and Silver.

A LADY'S RAMBLES AMONG THE JEWELERS.

The wearing of gems has never in the history of this country been so wide-spread and extensive as at the present time.

\*

A novelty for the table is a silver spoon with long handle in vine pattern, and shallow bowl perforated in a leaf design, for serving green peas.

\*

A new curling box of silver plate contains the usual lamp and curler: the novelty lies in the handle of the curler, which is supplied with a hinge that enables its being placed in a very small place.

\*

Numerous and charming are the combination sets for coffee and liquors.

\*

Simple bodices of chiffon or tulle are rendered things of beauty with gorgeous embroideries, fastened with diamonds, pearls and other jewels.

\*

Crushed morocco in shades of green is fashionable for card cases, purses and photograph frames.

\*

Attractive toilet sets come in canary yellow opaque glass, set in silver.

\*

Nothing more dainty can be imagined than some of the silver coffee sets which include Coalport china cups and saucers in new colorings and designs.

\*

A beautiful brooch is a star of diamonds with an opal centre.

\*

The artistic tendencies of designers is pleasingly illustrated in the newer tortoise-shell articles for the toilet and writing tables. Their intrinsic as well as artistic value is enhanced with gold or silver mountings.

\*

A charming necklace is composed of three rows of pearls fastened with an oblong shaped ornament of diamonds with a pendent pearl drop; this ornament is detachable and can also be utilized for a brooch or corsage decoration.

\*

Conspicuous for the beauty of its design is a hair ornament that blends fine scroll work with light feathery sprays of single small stones.

ELSIE BEE.

S. L. Ackerman, Scranton, Pa., has been closed by the sheriff on an execution for \$1,136.

The Armstrong Braiding Co., Portland, Me., have incorporated with a capital stock of \$75,000 in single shares of \$100, for the "manufacturing, buying and selling all kinds of braided, twisted and woven goods and jewelry." Bulkeley Wells, Manchester, Mass., H. L. Harding, Boston, Mass., and A. H. Armstrong, Sandwich, Mass., are the promoters.



**E. KIRSTEIN'S SONS CO.,**  
MANUFACTURERS OF  
**Optical Specialties,**  
ROCHESTER, N. Y.  
NEW CATALOGUE NEARLY READY.  
SEND US YOUR BUSINESS CARD.



## Why We Are Leading Locket Sellers.

Our line is most complete—Styles the very newest—We make lockets of all kinds—Gold Lockets, Gold Filled Lockets, Gold Front Lockets, Platinum and Gold Lockets,

Sterling Silver Lockets. We know all about Lockets—have nothing to think of or talk of but Lockets and similar goods. A large line of fobs, flat and drop seals.



Ask your jobber to show you our new Fall lines.

**WIGHTMAN & HOUGH CO.,** Providence and N. Y.

**Items of Interest in Connection with the St. Louis Convention.**

ST. LOUIS, Mo., June 18.—The National Republican Convention which convened in this city June 16, did not attract as many visitors to the city as were expected. The leading hotels made great preparations to accommodate the expected rush, which materialized only in part. Many out-of-town jewelers, however, availed themselves of the cheap railroad rates and came to the city. Among Illinois jewelers were the following: Phil Herbert, Murphysboro; Aug. Kalbitz, Red Bird; John G. Weber, Marine; T. C. Woodman, Greenfield; J. P. Dickie, Bunker Hill; Frank Barnett, Edwardsville; D. Richenbach, Carmi; Otto Rink, Carlyle; L. J. Appel, Highland; J. H. Booth and E. H. Goulding, Alton; A. Yarnall, Morrisonville; Fred Simon, Collinsville; J. M. Cunningham, Flora; G. Anderson, Taylorville; L. A. Gardner, El Paso; Mr. Knapp, Belleville; Mr. Trask, of Trask & Plain, Aurora; J. C. Klaholt, Springfield. Among Missouri jewelers were: Thos. Powell, Columbia; J. P. Shepard, Hannibal; J. A. Key, Piedmont; John H. Giergrich, Moberly; Chas. Mauch, of Mauch & Adams, Marshall; Aug. Wintler, Poplar Bluff; Nat. Strauss, Louisiana; E. S. Lawbaugh, St. Mary's; Wm. E. Sams, of Sams & Worden, Clinton; Geo. Porth, Jefferson City; H. R. Stevens, Nevada. From other points also a number came, among whom may be mentioned J. B. Hayden, Topeka, Kan., and J. C. Armstrong, Ottawa, Kan. The former is president and the latter is the ex-president of the Kansas Retail Jewelers' Association.

Wm. Riker, Newark, N. J., was one of the delegates to the National Republican Convention. It was the first time he had been in St. Louis for 15 years.

Mr. Gornelich, a prominent jeweler of Boonville, and a representative in the Missouri State Legislature, was an interested auditor.

J. G. Fuller, J. G. Fuller & Co., New York, was here last week, the guest of A. Kurtzeborn.

Several prominent jewelers from the south took in the convention. Clarence Fitch, Tampa, Fla., and L. M. Kneply, Dallas, Tex., were among them.

Business picked up quite a little last week at down town stores as a result of the numerous strangers in town. Phil. Frech, of the Phil Frech Watch & Jewelry Co., said he had three kinds of souvenir spoons in stock before the convention, but that he only has two now. One kind had a representation of the Convention Hall on it. They went out speedily and he could not supply all demands for them.

One of the novelties largely sold here to convention visitors was silver-plated plates with illustrations of the Convention Hall, Eads Bridge, Shaw's Garden and other St. Louis views engraved on them. The E. H. Kortkamp Jewelry Co. did a thriving trade in this class of goods.

The gavel which was used by the permanent chairman was received at the headquarters of the local committee Monday morning,

and turned over to the Mermod & Jaccard Jewelry Co., by Secretary Gaiennie. It was later presented to the chairman by Senator Berry, one of the Illinois delegates. The gavel is an excellent piece of wood carving, done by W. H. Bartels, of Carthage, Ill., who is reported one of the most artistic carvers in the country. Mr. Bartels selected the wood—a hickory log taken from the log cabin occupied by President Lincoln at New Salem, Ill., in 1832. There are panels on either side which are filled in with inscribed plates of gold and silver. The silver end bears this inscription:

Made by W. H. Bartels, Carthage, Ill.  
From a Log of the Cabin  
Occupied by Abraham Lincoln,  
In 1832, at New Salem, Ill.

The inscription on the gold plate reads:

National Republican Convention  
Held at St. Louis, June 16, 1896.  
Nomination.  
For President.

The gavel was to be presented to the nominee at the conclusion of the proceedings.

**Sudden Death of Warren S. Gurney.**

BROCKTON, Mass., June 19.—Warren S. Gurney, aged 57, of the firm of Gurney Bros., jewelers, was found dead in bed at his home, on Court St., this city, this morning. His family is at Monument Beach. The servant became alarmed at his non-appearance. An examination showed that he died from a stroke of apoplexy.

Mr. Gurney enlisted as a private in Company A, Fifty-sixth Regiment, Dec. 11, 1863, and was discharged at the close of the war. He was detailed as a musician in the regimental band recruited by P. S. Gilmore. Mr. Gurney was in the jewelry business from the end of the war, and for all but the first few years was a member of the firm of Gurney Bros. He leaves a widow and two grown sons.

**Death of Joseph Gosling.**

CINCINNATI, O., June 20.—Jos. Noterman & Co. are closed to-day on account of the death of Joseph Gosling, junior member of the firm. Mr. Gosling associated himself with Joseph Noterman, when the latter retired from the firm of Noterman & Jonas, some years ago. Two years ago he began to decline in health and resorted to every known means to ward off the dread disease, consumption, but to no avail. He spent the most of the last year in Colorado and Mexico and returned last Fall much improved, but he again gradually grew worse and was planning to go west when death overtook him. He leaves a wife and four children with a host of friends to mourn his loss.

The death of Mr. Gosling will not interfere with the business of the firm, which will continue the same as before. Mr. Gosling had not been actively connected with the business the past year owing to his poor health and his death was not a surprise to his nearest friends.



**Sterling Silver:**

1 Inch, - \$12.00 per doz.  
1 1/4 " - - 13.50 "  
1 1/2 " - - 15.00 "  
and upwards.

Silver Plate, - - } \$24.00  
Gold Plate, - - } per gross,  
Black and Oxidized, }  
assorted sizes.

**DEITSCH BROS.,**  
MAKERS,  
7 East 17th Street,  
NEW YORK.



**YOUR WINDOW DISPLAY.**

Is it as attractive as it might be? One or two Rogers Statuettes will add greatly to its interest. Send for beautiful Catalogue. Above depicted group, lists at \$8.00 only.

**ROGERS STATUETTE CO.,**  
441 PEARL STREET, N. Y.

## Death of John Hoare.

At about 4 o'clock Tuesday afternoon, June 16, John Hoare, of the cut glass firm of John Hoare & Co., Corning, N. Y., was in the private office of Edward Holbrook, president of the Gorham Manufacturing Co., 19th St. and Broadway, New York. Noticing that Mr.



THE LATE JOHN HOARE.

Hoare was showing signs of illness, Mr. Holbrook asked him if he was feeling well, to which Mr. Hoare replied that he was suffering from a severe attack of dyspepsia, at the same time expressing a desire to see a physician. Mr. Holbrook immediately sent for Dr. Norris, who responded at once. The physician found that Mr. Hoare was suffering from a gaseous trouble of the stomach, and gave him some remedies, after which Mr. Hoare went to his hotel, the Everett House. In the evening the physician called again, and immediately pronounced the disease angina pectoris. It was then deemed advisable to notify the sick man's family in Corning, which was done by telegraph. Mr. Hoare died at 1 o'clock, P. M., Wednesday, the remains being forwarded to Corning on the 9 o'clock P. M. train Thursday, the deceased's son, James, accompanying them.

CORNING, N. Y., June 19.—John Hoare was born in Cork, Ireland, April 12, 1822, and was the oldest but one of a large family of children of James and Mary Hoare. After learning the trade of glass cutting with his father, when he was 20 years of age he went to England, where he worked for different firms, rising from the position of journeyman to that of foreman. In 1848 he commenced business for himself and five years later, in 1853, he came to New York with his family, landing in America with a half sovereign as his sole resources. However his skill and experience enabled him to quickly find employment and he began work for E. V. Haughworth & Co. Determined to start into business, in one year, with five partners, he formed a glass cutting

firm of which he was the active member. Two years more passed and Mr. Hoare purchased the interest of two of his partners and the firm-name became Hoare & Burns. Later he purchased the glass cutting business of the Brooklyn Flint Glass Co., and the firm of Gould & Hoare were formed. In 1861 the firm became Hoare & Dailey, which was continued until 1868 when Mr. Hoare came to Corning, retaining, however, for several years his business interests in New York city.

Of his prominence in the cut glass business, the "Landmarks of Steuben County" says: "The statement must be made in full justice to him that among the men who have contributed to the establishment of the splendid industry of glass making and rich glass cutting in Corning, none are entitled to greater honor than John Hoare. In every department and detail of the art of glass cutting, Captain Hoare was skilled, whether as a designer or practical cutter. Indeed, in many respects he was a pioneer of the industry in America; he was the first man who turned glass in a lathe, and to-day his strongest and most formidable competitors in business are men who learned the art of designing and glass cutting in his shops and under his personal instruction." Mr. Hoare's firm have been awarded many prizes for their exhibitions, notably among them being the four World's Fair medals recently received.

The artistic and elaborate products of the firm have attracted the curiosity of travelers to so great an extent that a large portion of the time of the proprietor and his employes has been devoted to the instruction of visitors. No man was more affable, cordial and entertaining to a party of attentive, receptive and earnest guests. An hour with Captain Hoare was always a "feast of reason and a flow of soul." His fertile brain and deft hands produced and supplied the first complete set of cut glassware ever placed in the White House at Washington, which occurred during the second term of President Grant, comprising 100 different pieces of unrivaled design and finish. The first premium of Tiffany & Co. at the Paris Exposition in 1889 for mounted glassware was in a measure due to Mr. Hoare's talent and handiwork in the crystal art.

Although averse to public life, Mr. Hoare was prevailed upon to accept, in 1874, the Democratic nomination for President of the village of Corning. The nomination was indorsed by the Republicans and he received the entire vote of both parties. He was a member of the Masonic order, a 32d degree man, belonged to the Knights of Honor, and had passed through all the degrees of the Odd Fellows. While in Brooklyn he became a member of the National Guard, in Albany of the Military Association, and in England a Forester. He has ever since his residence in Corning been prominently identified with Christ Church, of the city, and has served as vestryman for over 20 years, and for several years has held the office of senior warden. He took great delight in his church and manifested his interest with liberality.

John Hoare was married to Catherine

Dailey, Nov. 16, 1845. Eight children have been born to the couple, four of whom are living. Six grew to maturity; they are: James, of the present firm of J. Hoare & Co.; Mrs. Catherine White, Mrs. Wm. H. Sayles, John, Jr., who died when 30 years of age, Timothy, who lived until he was 31, and Dr. Joseph D.

Personally Captain Hoare was beloved by all. His kind ways and gentle disposition always invited confidence. In his home he was an ideal father and husband. His fame as an entertainer was known far and wide, and in business he was loved by his employes, respected by those who dealt with him and admired by those who observed his methods. As a citizen no one loved Corning more, or did more for its advancement and welfare. He was an ardent Republican and protectionist, and his personal efforts and purse were ever at the service of his party. Although over 74 years of age, he was as active and energetic as a man of 40, and his sudden death will be regretted and cause sorrow in every household in Corning.

### Execution Issued to the Sheriff Against E. Happich & Co.

PHILADELPHIA, Pa., June 19.—Execution was issued this week from the Common Pleas Court in favor of Mrs. Tillie Gallaschick, formerly Ickler, and Mary Roessler, executrices of the estate of Jacob Ickler, against the firm of E. Happich & Co., jewelers, 230 N. 8th St. The members of the firm are Ernest P. Happich, William Kop, of this city, and Frank A. Vehe, of New Jersey. The executions were issued on a note for \$10,000, made on April 2, and payable in one day.

William Kop, a member of the firm, stated to a reporter that five years ago the present members of the firm, who were then employes of Jacob Ickler, bought out his interest and at his death agreed to pay his heirs the sum of \$25,000. Of this sum \$15,000 has been paid, and the amount represented by the note was the balance due by them. He said that the action of the executrices in having an execution issued was entirely unexpected, and that at the present time he could give no accurate statement as to the liabilities or assets of the firm, but that he was convinced that the stock on hand would be sufficient to meet all liabilities. He also declared that owing to the suddenness of the action it was impossible for him to state whether or not an assignment would be made.

### E. Howard Watch & Clock Co. to Supply the Government with Clocks.

WASHINGTON, D. C., June 19.—The Secretary of the Treasury has awarded the E. Howard Watch & Clock Co., New York, the contract for delivering ordinary clocks at the various public buildings east of the Rocky Mountains at \$12 each.

T. Howard Craig has moved from Oskaloosa, Ia., to Champaign, Ill., and on July 1 will open a new store. The new firm will be known as Ferguson & Craig.

# IMPORTANT.

## The United States Circuit Court of Appeals

has decided that the Colby patent for pendant setting Watch Cases is invalid, and from this decision there is no appeal.

We are, therefore, the only manufacturers and ours the only valid pendant set device used in the manufacture of pendant setting Watch Cases.

In answer to some inquiries made of us, we wish to say we do not manufacture a pendant setting Watch Case for the new model 16 size Elgin Watch movement.

**The Dueber Watch Case Mfg. Co.,**  
CANTON, OHIO.

**W. F. EVANS & SONS**  
ESTABLISHED 1805.  
SOHO CLOCK FACTORY,  
Handsworth, Birmingham, ENGLAND.  
TURRET CLOCK.

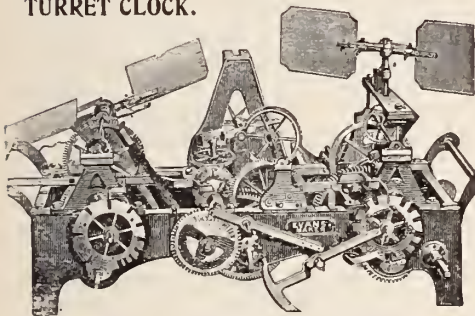

WESTMINSTER CHIMES.

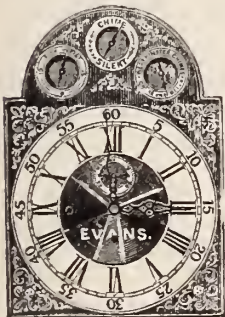

GRANDFATHER CLOCK.

With arch brass dials to chime upon Bells, Gongs, and Harrington's Patent Tubes.

DON'T FORGET THE JEWELERS' CIRCULAR PUBLISHING CO.'S BOOK LIST when in want of any technical book in the Jewelry or Kindred Trades.

MANUFACTURERS OF  
CHURCH,  
CHIME and  
QUARTER

**CLOCKS,**

SCHOOL AND  
HOUSE CLOCKS.

**A** **AMERICAN** ESTABLISHED 1872.  
INCORPORATED 1894.  
**WATCH TOOL CO.**

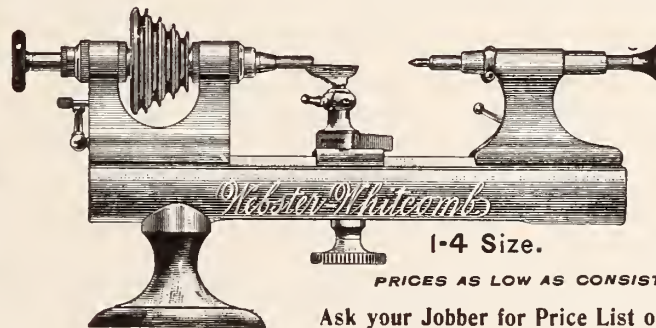

THE  
**Webster-Whitcomb**

GROWS IN POPULARITY

PRICES AS LOW AS CONSISTENT WITH QUALITY.

Ask your Jobber for Price List of 1895, or write to us at

**Stoney - Batter Works, Chymistry Dist., Waltham, Mass.**



**WE HAVE  
ON HAND**

A Large Number of Small

### Advertising Cuts

Specially Designed for JEWELERS'  
ADVERTISING, such as above, at

75 Cents per Electrottype.



SEND FOR PROOF SHEET.



THE JEWELERS' CIRCULAR PUB. CO.,

189 Broadway, New York.

### Sale of the 563 Diamonds Smuggled on the "Rhymland."

PHILADELPHIA, Pa., June 18.—Public sale was yesterday made in United States Marshall Reilly's office, of the 563 diamonds seized last Winter in the possession of Captain Frank Loeswitz, on the steamship *Rhymland*, and upon the charge of smuggling which from Antwerp to Philadelphia, Herman Keek, Cincinnati, O.,

or \$29.50 per karat. Lot No. 3 was knocked down to E. M. Poulin for \$900, or \$28.25 per karat. He also secured lot No. 4 for \$765, or \$28.25 per karat. L. Ottinger, of New York, secured lot No. 5 for \$735, or \$28.75 per karat. L. Brunhild, of this city, became the possessor of lot No. 6 paying therefor \$794, or \$29 per karat. Mr. Poulin managed to get the remaining three lots. For lot No. 7 he paid

pointed in the quality of the diamonds. Some were valuable stones, he said, but the majority were "yellow diamonds and badly cut at that." The feeling prevailed at the sale that some influence was being exerted to secure control of all the diamonds in order that they would never be known in the market as "the Keek diamonds."

### Call for the Meeting of the Alabama Retail Jewelers' Association.

BIRMINGHAM, Ala., June 19.—Wm. Rosenstihl, Jr., secretary of the Retail Jewelers' Association, of Alabama, has issued the following circular letter:

OFFICE OF SECRETARY  
RETAIL JEWELERS' ASSOCIATION OF  
ALABAMA ANNUAL MEETING.

BIRMINGHAM, ALA., June 19, 1896.

Dear Sir:—The secretary has been in correspondence with a majority of the members of the association, and in every instance all favor Montgomery as a meeting place, and as the National Convention will meet early in July at Atlantic City, N. J., and rather than be late the meeting of our association will be called promptly. We hope, at this convention, every member will be on hand. Laws must be framed for passage in our next Legislature, grievances must be presented, and business of every importance must be attended to. The meeting of our association is hereby called to meet Friday, June 26, 1896, at Montgomery, Ala. Delegates will be selected to National Convention. Answer without fail if you will attend.

WM. ROSENSTIHL, JR.,  
Secretary R. J. A., Alabama.

### Large Silver and Silver-plated Ware Factory for Hartford, Conn.

MERIDEN, Conn., June 19.—It is said that a new manufacturing enterprise is to locate in Hartford. The proposition is to combine the Norwich branch of the William Rogers Mfg. Co. and the sterling silver business now conducted by the Eagle company at Glastonbury, and remove the business to Hartford, where it will be conducted under one management. The William Rogers company have been the selling agents for the Eagle company and have created a demand for the product which exceeds the output of the Eagle Company's limited plant and capital.

The Rogers company will continue to act as selling agents and will be able to double their sales. President Watrous, of the Rogers company, is largely interested in the enterprise, which gives promise of being profitable and prosperous. The knife department at Norwich now employs 100 men and it is expected that the new concern will employ 250 to 300 men. F. W. Giddings, of New Britain, will be engaged in the management and he is quite a large stockholder. He has sold quite a quantity of stock in that city.



DEPUTY MARSHAL MARPLE AUCTIONING OFF THE DIAMONDS SMUGGLED ON THE "RHYMLAND."  
[From the Philadelphia Times.]

was recently convicted and sentenced to one year's imprisonment and to pay \$200 fine. The diamonds were forfeited to the United States. There was about 100 persons present, and many of them were experts and dealers in precious stones.

Chief Clerk Thomas Marple was the auctioneer. The buyers were required to pay \$100 down, and the balance after the confirmation of the sale by Judge Butler. The diamonds were arranged in nine lots. Each lot was in a separate bottle, on which there was a label, stating the number of stones and the number of karats.

The first lot, consisting of sixty-four stones, weighing  $24\frac{1}{2}$  1-64 karats, was sold to E. M. Poulin, of Boston, for \$2,104.56. The bidding was started at \$20 per karat and stopped when it reached \$30.50. It advanced but 25 cents at a time, and a score of those present took a hand in the game before the top notch was reached. L. Brunhild got lot No. 2 for \$710,

\$651, or \$28 a karat; lot No. 8, \$692, which is \$29.75 a karat, and lot No. 9, the most valuable of them all, \$510, or \$33.50 a karat.

The sale occupied a little less than an hour, and the total amount realized was \$7,863, as against an appraisement of \$6,700.

There were only two purchasers; E. M. Poulin, Boston, Mass., bought lots 1, 3, 4, 7, 8 and 9—weighing about 148 karats. L. Brunhild, Philadelphia, brought lots Nos. 2 and 6, and, after the sale, a party who had purchased lot No. 5, threw it into Mr. Brunhild's purchases, and the three lots were charged to Mr. Brunhild. The proceeds of the sale go to the Government. It was the general opinion among the parties present that good prices were realized.

Some of the dealers present thought that the diamonds were to be disposed of in one lot and they intended to bid on the stones. One expert who represented a prominent Chestnut St. firm said that he was disap-

ESTABLISHED 1849.

INCORPORATED 1890.

**J. BRIGGS & SONS CO.,**

MANUFACTURERS OF

**Gold and Silver Plate and Seamless Wire,**

65 CLIFFORD STREET, PROVIDENCE, R. I.

WE MAKE



STOCK FOR

CANE HEADS,  
UMBRELLA MOUNTINGS  
PENCIL-CASES,  
WATCH-CASES,  
WATCH-CROWNS,  
THIMBLES,  
SPECTACLE AND  
EYE-GLASS BOWS,  
DIAMOND MOUNTINGS,  
&c., &c., &c.

### Interesting Speeches at the Testimonial Dinner to John Gordon Gray.

We recently received from Queen & Co., Philadelphia, a pamphlet reproducing the speeches at the Testimonial Entertainment given by the stockholders and late creditors of that firm to John Gordon Gray, on Thursday evening, April 16, 1896. Perhaps the most interesting feature in the addresses was that of Mr. Gray in which he reviewed the circumstances which led to the failure of the house.

"I cannot accept for myself alone the kind expressions of your Chairman," said Mr. Gray. "That I am here to-night is simply due to the fact that circumstances chanced to make me the representative in a matter of some importance to a number of people. The house of Queen & Co. had gone through the long financial strain following upon the panic of 1893, bending under the weight of a large indebtedness incurred partly through the necessity of providing for the wants of a rapidly extending business, whose development, just as it seemed to be on the point of almost indefinite expansion, was suddenly arrested by the narrowing of manufacturing and railroad enterprise throughout the country. And when, in August, 1894, to these causes of commercial depression were added the increasing difficulty of making collections and the calling in of loans, and that word of dread to commercial ears, 'assignment,' was spoken, there was but one sentiment among those interested in the house, and that was that at whatever cost every debt must be paid in full. [Applause.] While it is true that the indebtedness was large (it was about \$180,000), the assets also was large, being more than two to one. On the other hand, the expert appraisers appointed by the court, in making an appraisal on the basis of such prices as the assets might be expected to bring at public sale, appraised them at little more than half of the indebtedness.

"Everything then depended upon how we should be permitted to handle those assets. When Dr. Johnson went about with ink horn and quill, making an inventory of Thrales' brewery, he said: 'We are not selling vats and kettles and tubs, but the potentiality of wealth beyond the dreams of avarice.' All businesses are not breweries, and few businesses, especially in these times, I am sorry to say, have such potentiality as the good doctor described; but all are alike in this respect, that their principal asset is their potentiality of money making. It was our good fortune to be enabled to preserve our assets from degenerating into 'vats and tubs'—tubs which, if thrown upon the public, would have been of even less value than those of the ordinary kind. Through the kindness of our creditors the business was preserved in life; its factories and industries went on in their usual course; its workmen were kept at work and their wages paid; its connections, customers, and agencies were retained; and every one connected with the house—the managers, superintendents, and employes in general—worked with earnest and self-sacrificing effort to assist me, in a spirit that deserves my warmest acknowledgment. Mr. Samuel L. Fox, long the head of the house, who had for some time been practically out of the active management, returned to work again, placing himself wholly at the command of the house, and working with his old-time energy and with inspiring courage and self-forgetfulness for its rehabilitation.

"My grateful thanks are due to my counsel, Mr. Jones, Mr. Carson, and Mr. Beeber, who displayed an even more than professional interest in the preservation of the house and to whose advice I owe much. And to the Creditors' Committee my thanks and the thanks of

every one connected with the house are due. To them—standing, as they did, between the creditors and the assignee, and representing the confidence of the creditors in the work that was being done—we owe it that we were enabled to proceed without complication. And, finally, to the great body of the creditors themselves we owe everything for that time which was so valuable. 'Time and I,' said Walter Scott in the midst of his difficulties 'time and I against any two.' This 'time,' so necessary, so indispensable to us, we owe, gentlemen, to your wise and generous forbearance. Again I thank you all."

The address of Prof. E. J. Houston, on the necessity of scientific investigation, brought out many points of interest to opticians. He said among other things:

"Scientific men are to a certain extent divided into two classes—those who think that the highest phase of science is found in what they call pure science, *i. e.*, conceptions which are never actually carried into execution, and those who believe that the highest phase of science consists in the practical application of the conception. In this as in similar cases, I think, the truth is to be found in an intermediate position, *viz.*, that the highest phase of science comes from a combination of both the pure and the applied; but in these busy days it not infrequently happens that neither the pure nor the applied sciences are able to do all the work that is required. It seems to me that it is eminently fitting that in a club of the character of the Manufacturers' Club a question of this kind should be discussed. We live in a city that is one of the first manufacturing cities on the continent; a city that has both numerous laboratories and institutions in which students are prepared for working in laboratories. So far as the results are concerned there is very little difference between a laboratory experiment and the actual manufacture of some finished product from raw material, save on the scale upon which the processes are carried out. There is, however, a very great difference, from the pocketbook aspect, as between the failure of the laboratory experiment and a failure in the character of the product of a large manufacturing establishment. The highest phase of physical science is found when its conceptions are materialized by actual application in the laboratory. It goes without saying, therefore, that any association or company that can embody in a workable form the ideas that have been evolved in pure science and carried out in applied science, must prove of very great value, not only to science itself, but to the community at large.

"I only need call your attention to the eminent standing in the scientific world of some few of the manufacturers of philosophical instruments and instruments of precision. I know that comparisons are invidious, and in particularizing in this off hand way from mere memory I may omit some very celebrated names, but among those that now occur to me I would mention Koenig, of Paris; Hartman & Braun, of Germany; Salleron, Dubosq & Runkhorff, of Paris; Société Gènevoise, of Geneva and Elliott, of London, and our own Queen & Co., of Philadelphia. These are names that are known all over the scientific world. To see those names stamped upon a piece of apparatus means reliability and accuracy. Many of the gentlemen whose names I have mentioned occupy very high positions, indeed, in the scientific world. It seems to me that it is not necessary to claim for J. W. Queen & Co. the right of public recognition merely from my standpoint as an electrician because of their ability to make good electrical apparatus (and we all know that they can do this), for should I do so I should perhaps slight the great amount of equally good work they do in other directions.

"It seems almost like 'carrying coals to

Newcastle' to tell the people of Philadelphia of the efficient character of the work performed by J. W. Queen & Co. in their various departments of optical instruments, mathematical instruments, microscopic and philosophical apparatus, magic lanterns and stereopticons, a host of meteorological apparatus, photographic apparatus and supplies, and, last but not least, chemical apparatus. But it would, however, be unfair to them if, in this very brief *résumé*, I did not call attention to a phase of their manufacturing interests in which Messrs. J. W. Queen & Co. occupy a very exalted position.

"Philadelphia is essentially the city of medical colleges. It is probably (and in saying this I trust I am not treading on the toes of any visitor) 'the' center of the medical sciences and professions. But, do you know, gentlemen, that it is also entitled to the distinction of being, probably, if not the most, one of the most celebrated centers for the manufacture of optical apparatus that exists in any part of this country? There are probably more opticians and oculists in Philadelphia, proportionately to the population, than in any other large city. And the reason, I think, is evident. In 1864 Dr. Donders, of Utrecht, published a very remarkable book—remarkable then but not now, in this age of the rapid multiplication of books and birth of new ideas—entitled 'The Anomalies of Accommodation and Refraction of the Eye.' There was in existence at that time a very wide-awake firm, that of J. W. Queen and S. L. Fox, who at once saw their opportunity, both as business men and as scientific men. They made a study of the principles of Dr. Donders' work, and in this way there was brought about what, I suppose, we might call a wedding or union between the oculist on the one hand and the practical optician on the other—a result which has been prolific of good to that portion of humanity that feels itself growing older and needs to have its defects of vision accommodated."

### Prompt Capture of a Desperate Burglar.

PROVIDENCE, R. I., June 19.—A successful attempt was made some time Sunday night to burglarize the larger retail store of Herman A. Ockel, Westminster St. The store is located on the second floor of the Phenix building, and includes two rooms. The place was closed up as usual Saturday night, and when the clerk arrived Monday morning to open up, he discovered everything in confusion. Mr. Ockel was immediately notified, and a hasty examination revealed the shortage of several hundred dollars' worth of goods. The detectives were at once notified, and it was not long before they had obtained a clue which resulted in disclosing that the burglars were three negroes who had committed the deed in broad daylight during Sunday afternoon. They had cut their way through a door in the rear room, and while one of the trio watched in the hallway the others proceeded to loot the store. The booty was dropped from a rear window, and taken away in a wagon.

Monday afternoon the detectives were notified that a negro was at the store of John Nelson, N. Main St., with a lot of jewelry, clocks, etc., that answered the description of the goods taken the day before from Ockel's place. Detectives Cannon and Nickerson proceeded to Nelson's and arrested a man giving his name as Henry Turner. A portion of the booty was found upon him and he was locked up. He pleaded not guilty, but would not tell who his companions were.

**Decision in the Suit of the Whiting Mfg. Co. vs. the F. M. Whiting Co.**

The following is the full decision of Judge Pryor, of the New York Supreme Court, in the suit for temporary injunction of the Whiting Mfg. Co., New York, against the F. M. Whiting Co., North Attleboro, Mass., to restrain the latter concern from using their trade-mark and corporate name:

N. Y. SUPREME COURT,  
Special Term, Part I., May 1896.

Whiting Manufacturing Co.

vs.

F. M. Whiting Company.

PRYOR, J.

Memorandum.

The discretion of the court in granting or withholding an injunction *pendente lite*, is determined by these considerations:

1. If the injunction be sought under subdivision I, section 604 of the Code, to prevent an act which would render the judgment ineffectual, the relief will be readily conceded; because otherwise by success in the suit plaintiff would receive no reparation for his wrong. But, if the interim injunction is to issue pursuant to the provisions of section 603 of the Code, and so accords upon a motion relief title to which must be determined by a full and formal trial, then as by the ultimate decision the claim may be defeated, the court will refuse to anticipate the judgment by an interlocutory stay, unless the right be clear and the occasion exigent. *Bronk v. Rilet*, 50 Hun. 489-492. *Van Vechten v. Howland*, 12 Abb. N. S. 461, *Howe v. Howe Machine Co.* 50 Barb. 236; *Hart v. Ogdensburg, etc.*, Co. 20 Suppl. 918; *Olmsted v. Loomis*, 6 Barb.; 152 *Electric, etc.*, Co. v. *Whiting* 17 Weekly Dig. 263. This distinction in the grounds and objects of preventative *reliefe pendente lite* reconciles an apparent conflict in the authorities, and accounts for the greater facility with which preliminary injunctions are allowed in one class of cases than in another.

2. Unless meanwhile irreparable injury will ensue to the plaintiff, ordinarily he will be denied an interim injunction, and be left to establish his right by plenary proof upon the trial. *Grill v. Wiswall*, 82 Hun. 281; *Howe v. Howe & Co.* 50 Barb. 236.

3. So, laches in the assertion of the right, will be fatal to an application for a preliminary injunction. *Van Rens v. The New York College &c.*, 4 Hun. 620; *Estes v. Worthington* 22 Fed. Rep. 822 1 High on Injs. Sec. 7.

The action is for an injunction against the infringement of plaintiff's name and trade-mark, and the motion, to restrain the defendant *pendente lite*. Defendant contests the claim both as to name and trade mark; but I am of the opinion upon the proofs, that plaintiff's right, in either aspect, is free from reasonable question. My doubt is as to the violation of the right. "Whiting Manufacturing Company" is obviously not an identical appellation with "F. M. Whiting Company." Nor is it clear that the public has been so misled by the similarity of names, as to patronize the defendant under the impression that it was dealing with the plaintiff. As to the trade marks, when distinctly stamped, it is impossible, with the least attention, to confound the two devices. But they are habitually printed by both parties so small and so faint as to be undistinguishable except upon the closest scrutiny or by the eye of an expert. The confusion, then, arises not from similarity of figure, but rather from obscurity of impression. Does a deception so caused and

for which each party is responsible give a right to injunctive relief? The proof is that the devices are indistinctly stamped from the necessities of the trade. Was it not incumbent upon the defendant to select a trade mark with reference to this necessity, and so peculiar as still not to be mistaken for plaintiff's? I incline, though not without difficulty and hesitation, to the conclusion that the plaintiff may maintain the action for injunctive relief; but I am confident that the right is not so manifest nor the occasion so urgent as to justify an interdict upon the defendant before judgment. It appears, moreover, that the plaintiff has been apprised, perhaps for several years, of defendant's infringement, and has itself dealt in defendant's wares stamped with the challenged trade mark. This, in not such acquiescence as to bar relief, involves at all events an admission on plaintiff that its injury is not so grievous and irreparable as to require instant redress by the extraordinary process of injunction. The cause may be tried in October; and for any damage which the plaintiff may sustain meanwhile the defendant is abundantly able to respond. *Howe v. Howe Machine Co.*, 50 Barb. 286; *Central, etc. R. R. Co. v. Bleecker St. etc. R. R. Co.* 49 How. 233.

**The Trial of Marcus Marks.**

SYRACUSE, N. Y., June 21.—The case of Marcus Marks, charged with the larceny of \$2,500 worth of diamonds from Becker & Lathrop, was recalled for trial on Monday.

One of the most bitter and personal of legal fights known in the history of criminal trials in the county of Onondaga was participated in by Assistant District Attorney Cowie, when in opening the case, he referred to the prisoner's "well-known standing in the criminal world." This, followed by similar remarks, aroused the resentment of attorney Edgar N. Wilson, who appears for Marks, and occasioned a scene which made the intervention of the Court necessary to avert a personal collision. The jury were excused temporarily in order that their minds might not be affected by the charges that counsel made against each other in connection with the case.

E. Gilbert Lathrop, of Becker & Lathrop, was the first witness called, and related the story of the robbery and identified the prisoner as one of three men who entered his store and committed the crime. On Thursday the examination of Mr. Lathrop was continued, counsel for prisoner endeavoring to break down his identification of Marks. With his cross-examination began a scene of abusive bulldozing such as has seldom been witnessed in the courthouse, and which repeatedly called for the interference of the Court. In fact this line of conduct went so far that prisoner's counsel narrowly escaped commitment for contempt, his idea being apparently that it was his function to conduct the District Attorney's side of the case as well as his own, and also to regulate the conduct of the Court.

At Friday's session the matter of identification was continued with much quarreling between court and counsel. The question of identity turned on the clothes worn by the three men concerned in the robbery. On Saturday a big row broke out over the admission of a photograph claimed to be that of Marks and which had been identified by some previous witnesses as Marks' picture. The

jury were entitled to a half holiday on Saturday afternoon, but preferred to continue on with the case. Saturday afternoon was also taken up with the subject of identification and court adjourned until Monday at 10 A. M. The trial is expected to last until Wednesday at least and possibly longer.

**Organization of the Opticians' Society of Pennsylvania**

PENNSYLVANIA, Pa., June 22.—The Opticians' Society of Pennsylvania organized in the Hotel Lafayette this evening and concluded before adjournment to admit New Jersey to all the rights and privileges of the organization. Fully 50 active practising opticians were in attendance, the representative men including C. S. Gill, Lancaster, Pa.; C. Peoples, Chester, Pa.; Geo. F. Applegate, Trenton, N. J.; H. C. Herman, Williamsport, Pa., and J. E. Boyle, Lancaster, Pa.

Mr. Herman acted as temporary chairman, and a permanent organization was effected as follows: President, A. Martin; 1st vice-president, H. C. Herman; 2nd vice-president, C. A. Longstreth; secretary, F. A. Haines Moore; treasurer, T. E. Leech.

Letters regretting their inability to attend the meeting were received from B. S. McGlenn, Pittsburgh; A. J. Potter, Frankford; Dr. H. M. Smith, Scottdale; J. C. Shapley, Mechanicsburg, and Kauffman Bros., Harrisburg, all of Pennsylvania.

The members of the executive committee in addition to the officers are: C. S. Gill, Lancaster; G. S. Brinkersopp, West Philadelphia; and C. H. Flagg, Philadelphia.

**Last Week's Arrivals.**

**THE CIRCULAR** has perfected arrangements for obtaining the names and hotel addresses of all the latest buyers visiting New York, and each day posts in its office, 189 Broadway, a bulletin which every member of the trade is cordially invited to copy.

The following out-of-town dealers were registered in New York during the past week: F. B. Sherman, jewelry buyer for B. F. Larabee & Co., Boston, Mass., Vendome H.; J. H. Foster, jewelry buyer for Dey Bros., Syracuse, N. Y., 66 Grand St.; H. E. Kirshtein, Rochester, N. Y., Hoffman H.; B. Ginsburg, Boston, Mass., Normandie H.; E. E. Ephraim, Galveston, Tex., Astor H.; L. C. Reisner, Lancaster, Pa., Astor H.; E. D. Vosburgh, Binghamton, N. Y., Grand H.; M. Streicher, Chicago, Ill., Astor H.; F. A. Drexel, Detroit, Mich., St. Denis H.; J. Hyman, Chicago, Ill., Hoffman H.; J. Mitchell, Toledo, O., Metropolitan H.; P. F. Slade, jewelry buyer for Tootle, Wheeler & Motter, St. Joseph, 338 Broadway; J. G. Kent, Toronto, Can., Astor H.; J. Serex, San Francisco, Cal., Astor H.

Optician Dr. J. L. Wronker, New London, Conn., distributes free to all who will call at his office a book treating on the errors of sight.



## News Gleanings.

A. J. Burnham, Aurora, Ill., has sold out.  
 M. Kentwortz, Waterman, Ill., has sold out.  
 George Horspool, Galesburg, Ill., is selling out at auction.  
 Max Frumin, Steelton, Pa., has removed to 41 N. Front St.  
 T. A. Robinson, Erie, Pa., has mortgaged real estate for \$1,000.  
 A. S. Keller, Marion, O., has been succeeded by Keller Bros.  
 The store of R. J. Bachar, Carey, O., was lately damaged by fire.  
 Frank Herr has removed from Egg Harbor, N. J., to Ocean City, N. J.  
 Alex. Hobbs, Milton, Mass., has given a real estate mortgage for \$2,500.  
 Anglade Bros., New Orleans, La., have dissolved; Wm. Anglade will continue.  
 Davidheiser & Bower, Birdsboro, Pa., have removed to a building on Furnace St.  
 The Buskirk Jewelry Co., of Boston, have closed out business at Ticonderoga, N. Y.  
 Max Meyer & Bro. Co., Omaha, Neb., have sold out the bulk of their stock of jewelry.  
 H. U. Seaman, Washington, Pa., has removed to the Brady building, in that town.  
 E. A. Phelps, of Phelps & Miller, San Francisco, Cal., has given a mortgage for \$5,000.  
 S. P. Emelle has moved his jewelry business from Rock Springs, Wyo., to Montpelier, Idaho.  
 In a fire in Lamar, Col., a few days ago, the jewelry store of L. W. Keil suffered a loss of \$500, insured.  
 Samuel Henderson, Springfield, South Dak., has mortgaged his store for \$500 and refuted for \$350.  
 Alma Marker, Idaho Falls, Idaho, recently sustained a small burglar loss in her jewelry and stationery store.  
 The marriage of W. E. Blocher, jeweler, Chambersburg, Pa., and Miss Blanch Ash, Allegheny, took place June 23d.  
 The suit for \$904 brought by the Northwest Watch & Jewelry Co. against J. Jaskulek, Portland, Ore., has been dismissed.  
 The stock and fixtures of the Diamond Palace, Missoula, Mont., were recently sold by the sheriff for \$2,000 to W. E. Graham, who bid them in for the creditors.  
 Tony Hill, a negro jeweler of Atlanta, Ga., was sent to jail in default of a \$1,000 bond last week, by United States Commissioner Broyles, for making and passing counterfeit money.  
 The regular monthly meeting of the New York State Association of Opticians was held at their rooms in the Pike Block, Syracuse, N. Y., on June 17th. An executive session was held and business of importance discussed.  
 The jewelry and notion store of W. Y. Bygate & Co., Pittsburg St., Scottsdale, Pa., was burglarized a few nights ago of between \$200 and \$300 worth of goods, most of which was in the jewelry line. The robbers gained

entrance by boring the lock off the door.

Edward Tyler and Walter Grossman, two young white men from Manassas, were arrested in Alexandria, Va., last week on a telegram from the town sergeant of Manassas. Tyler has been engaged in the jewelry business there for several years, while Grossman claims he is a barber out of work.

L. A. Piaget & Co., Paterson, N. J., in competition with several of New York's jewelry firms, have received the award of the contract for making the badges to be awarded to the survivors of the century road race, June 20th, under the auspices of the Associated Cycling Clubs of New Jersey.

Edmund F. Baumgart, June 16 filed application in the Civil District Court in Houston, Tex., to have his disabilities of minority removed, alleging in his petition that he is possessed of about \$300 capital, which is controlled by his mother as guardian; that he is now enabled to purchase a stock of jewelry and engage in that business with which he is familiar, and that it is his means of making a livelihood.

William C. Snyder, who officiated as sovereign commander of the local Knights of Malta in conferring the Red Cross Degree upon 50 candidates on the evening of June 18, in Shamokin, Pa., was found dead in bed next morning. He was in unusually good health and spirits at midnight, but expired from rheumatism of the heart. Mr. Snyder was exactly 31 years of age at the hour of his death. He was a leading jeweler of Shamokin.

Mrs. Edna M. Hill has filed a bill in the Superior Court in Chicago, Ill., for a divorce from her husband, William T. Hill. The latter is engaged in the wholesale jewelry business at 207 State St. In her bill Mrs. Hill tells the court that her husband owns real estate valued at \$75,000 and that he is also the owner of personal property to the value of \$20,000, and she asks that the defendant be directed to pay her alimony. He is accused of great cruelty.

On Thursday a suit was on trial in Judge Neff's room of the Common Pleas Court, Cleveland, O., against Helen S. Shields, wife of the ex-County Treasurer, for the recovery of \$1,500. Sipe & Sigler, jewelers, want the above sum for goods they claim to have sold to Mrs. Shields. One day two years ago Mrs. Shields says that her attention was attracted by a man ringing a bell in front of Sipe & Sigler's store. She entered and selected goods amounting to \$1,500, which she ordered laid aside for her. She says further that she commenced to hear complaints from other women who had purchased goods there. She then went back to the store and refused to pay for the goods.

Last Monday night the town of Manassas, Va., was considerably excited over the sudden departure of two young men, Edward Tyler and E. H. Lyles. They have been in partnership in the watch repairing and jewelry business for several months. They had not paid their rent, and the owner of the store room levied upon their goods to recover the amount due him. They took with them sev-

eral watches, two of which they pawned Tuesday morning in Washington, before their arrest, for \$8 and \$10 respectively. They were apprehended by the sheriff on the charge of felony, but producing the goods, they were tried and convicted for attempting to remove from their store goods which had been levied upon. They were sentenced to 30 days each in jail.

Samuel Herst, who for a long time past had a jewelry store in Springfield, Ill., has gone from the city and left a number of creditors behind him. For a long time he was located at E. M. Kreigh's place, at 214 S. 6th St., and recently his store here was robbed. Mr. Kreigh took up a subscription for him at that time, and succeeded in raising about \$400. Mr. Herst had been out of the city for two weeks, but only in the last few days has his absence been discovered by his creditors. It is understood that he has gone to Denver, Col., and that his wife and three children are now making preparations to join him there. His stock was all purchased on the instalment plan, and this was all sent back to the dealers.

## New Jewelry Businesses.

H. W. Elden, Bendersville, Pa.  
 A. C. Norton, Port Allegany, Pa.  
 J. Wells, 39 Chenango St., Fairfield N. Y.  
 M. Hamberg, 2006 Orthodox St., Frankford, Pa.  
 Herman Idzal, Hotel Aborn block, Des Moines, Ia.  
 C. Goldstein, optician, 1404 Main St., Columbia, S. C.  
 E. M. Love and C. W. Costella have formed a partnership and engaged in the jewelry business in Lake City, Ia.

## All the Creditors of H. H. Day to Share Equally in the Estate.

TACOMA, Wash., June 16.—Judge Parker has given a decision in the assignment case of H. H. Day, the insolvent jeweler, over which there has been some controversy between the secured and unsecured creditors. He held that the assignment to Dr. J. W. Cloes was made prior to the chattel mortgages on the stock given to certain preferred creditors, and that on this account the lien of unsecured creditors was of equal force with the mortgages. Under the decision all of the creditors, both secured and unsecured, will be allowed to share equally in the proceeds of the estate.

**Balance-spring Tables.**—A round plate of brass of about 22 mm. in diameter and one mm. in thickness, stands upon four small feet, about 10 mm. high, flat on top and furnished with nine small holes for the reception of cylinder as well as anchor or chronometer balance-springs, and to offer facilities for turning them upon it. This little table is preferable to the riveting too commonly made use of for this purpose.

## The Painted Hands of Dummy Clocks.

The publication in THE CIRCULAR of the letter from one of the staff of the *Christian Advocate* in reference to the painting of the hands on dummy clocks, together with the article which appeared some years ago in the *New York Sun* which first announced that the

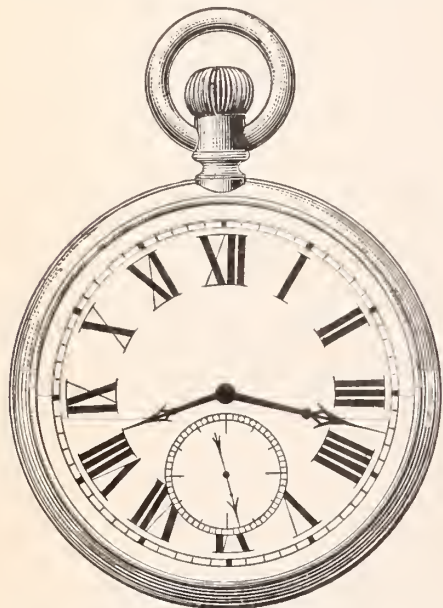

A DUMMY CLOCK SHOWING POSITION OF HANDS.

disposition of these hands, namely, pointing to 8:18 o'clock, had some connection with the death of Abraham Lincoln, has aroused considerable discussion on the subject, as will be inferred from the subjoined letters and newspaper editorial:

BOSTON, Mass., June 15th, 1896.

Editor of THE JEWELERS' CIRCULAR:

The article in your issue of June 10th, as to the painting of of dummy clocks hands to show the time as eight o'clock and eighteen minutes is very interesting. But why, may I ask, should any paper, especially one like yours, seek to perpetuate an error when it so easy to expose it? If "the reader of the *Sun*, who was an observing man" had been of an inquiring mind as well he would have learned that President Lincoln was shot at a few minutes after ten, or somewhere between ten and half past, or about two hours after the time noted on the signs alluded to. The statement of the son of the artist that "this disposition of the hands had some reference to the assassination," will do for the penny a liner to pad his articles with, but the editor of THE CIRCULAR should nail all such lies and not send them sounding down the years to deceive the people who are all too ready to believe what they see in print.

Yours very truly,

WM. P. SHREVE.

If Mr. Sheve will again read the matter in THE CIRCULAR of June 10, he will see that we do not positively endorse the story of Mr. Washburne, but reprint it so as to give the source of the tradition. It is reasonable to suppose that a man who has been painting clock faces for over 30 years should possess more or less knowledge as to why he

has in every case painted the hands to represent a certain hour and minute. If Mr. Washburne states the truth, as far as he is concerned, the discrepancy between the true time Lincoln was shot, 10.30, and that as represented by the dummy clocks, 8.18, may be due to an error on the part of the person who ordered the first dummy. Old watch and material dealers have always thought that the position of the hands denoted the time of the shooting of Lincoln. However the scientific reasons for the disposition of the hands, given in the following letter from Read Benedict, are worthy of consideration:

NEW YORK, June 19, 1896.

Editor of THE JEWELERS' CIRCULAR.

My attention has been called to your answer to a question in relation to the hands of dummy clocks. Sometime ago I had occasion to send the following communication to the *New York Sun* which may throw some light on this question.

Yours truly

READ BENEDICT.

To The Editor of The *Sun*—SIR: I saw in a newspaper of Friday last a statement that the hands of dummy or sign clocks generally indicate 19 minutes past 8 o'clock because at that minute and hour Abraham Lincoln died. This is an error, for history tells us that the martyr President died at 7:22 in the morning, a fact which can easily be ascertained.

Some time since the editor of the *Literary Digest* asked our opinion why these clocks were thus painted, and our answer was printed in that journal. It seems that dummy clocks or watches indicate 8 o'clock and eighteen and one-half minutes, because that is the position on the dial where time can be shown, the hands being on opposite sides, and making a perfect angle, and also being equally distant by minute marks or degrees from the figures 12, taking that as a starting point. We admit though, that the hands can be reversed, indicating 3 o'clock, 41 1-2 minutes.

There is but one other place on the dial where the time would be correct, and show the hands equally distant from the figures 12, that is at 13 3-4 minutes past 9 o'clock, or, with the hour and minute hands reversed; but this would not be so desirable, as the hands would be almost directly at right angles across the face of the dial. This can be easily tested by any one with his watch.

It must be remembered that while the minute hand makes the circuit of the dial of sixty minute degrees, the hour hand moves but five-minute degrees, therefore the movement of the hour-hand one minute degree necessitates the movement of the minute hand twelve minutes, or one-fifth of the whole.

We have in our possession an old dummy sign watch, used by the late Mr. Samuel W. Benedict in the early part of the present century, manufactured long before the death of the lamented Lincoln, which indicates exactly 8:18 1-2 o'clock.

Yours Truly, READ BENEDICT.

Under the title, "Curious Origin of a Trade Custom," the *Buffalo, N. Y., Commercial*, of June 13, published the following editorial:

"One of the staff writers of the *Christian Advocate*, under date of June 2nd, sent a note to a trade journal, THE JEWELERS' CIRCULAR, asking for information as to the authenticity of the story that the hands of all dummy clocks used for advertising purposes point to eighteen minutes past eight, 'because Lincoln died at that time.' The writer says:

Some time since I saw a paragraph stating that after Lincoln's assassination the National Jewelers' Association

passed a resolution to the effect that all dummy clocks used for sign or advertising purposes should be painted to mark the hour when the martyred President died. This seemed to me a very beautiful idea, and I gave the alleged fact to the readers of the *Advocate* of whose editorial staff (as Lincoln would say), "I am one of which." Thereafter for a time I revolved in admiration of the sentiment of the Jewelers' Association, but was rudely awakened by discovering that Abraham Lincoln died at 7:23 A. M., and not at 8:18, the hour usually represented on the dummy clocks.

"THE JEWELERS' CIRCULAR further explains that there was no National Jewelers' Association in existence in 1865, and that the present association had no connection with the matter. Then it quotes from the *New York Sun* of Nov. 18, 1888, an explanation that it regards as trustworthy: 'A reader of the *Sun* sent a letter to that office, asking why it was that every clock and watchmaker who hung an imitation clock or watch outside his shop as a sign had the hands painted on the face exactly 18 minutes after 8 o'clock. This was a poser to every clock seller a reporter asked. The signs came that way to them, they said. The majority of them had never noticed the curious coincidence. Investigation showed that three men, one Washburn, in New York, Grout, in Chicago, and Smith, in Cincinnati, made most of these dummy clocks. The pioneer in the business was Washburn, who told the *Sun* man that up to April 14, 1865, he painted the hands without rule; after that always at 18 minutes past 8. The night Lincoln was killed, said he—

"I was making a great clock to hang outside Adams came running in while I was at work. He was a strong Lincoln man. He said:

"Point those hands at the hour Lincoln was shot, that the deed may never be forgotten."

"I painted the hands, therefore, at eighteen minutes after eight. The idea struck me forcibly, and when I came to look at the effect I found it was the most convenient arrangement, since it displayed both the hands well, and left the top half of the clock free to paint in the name of the clock seller if desired.

"So I threw all my stencils away and made new ones for that hour. I have never varied from the system since, and that's the reason all the clock signs point as they do. The Chicago and Cincinnati people, I find, are doing the same thing. They don't know the story, but they were probably won to my plan by the capability of that particular arrangement for artistic display in painting."

"THE JEWELERS' CIRCULAR remarks that it has seen Mr. Washburn's son about this story and that he substantiates it. The account questioned by the correspondent of the CIRCULAR was wrong mainly in making the moment that in which Lincoln died instead of the one when he was shot. The only criticism we have to offer on what seems so interesting a contribution to the subject of trade customs is that Lincoln happened to be shot at five minutes past ten and not at eighteen minutes past eight. Still we would not think of insisting that a small fact like this should be used to spoil a curious tradition."

An enterprising Philadelphia jeweler in business during the Summer in Atlantic City, on the boardwalk, has offered to supply a solid gold spike upon which he will engrave the name of Mrs. F. P. Stoy, wife of the Mayor, the date of the dedication, etc., provided the authorities will agree to have the spike driven into the walk in front of his place.

# The Jewelers' Circular AND HOROLOGICAL REVIEW.

PUBLISHED EVERY WEDNESDAY BY

THE JEWELERS' CIRCULAR PUB'G CO.,

189 BROADWAY, NEW YORK CITY.

A JOURNAL DEVOTED TO THE INTERESTS OF JEWELERS, WATCHMAKERS, SILVERSMITHS, ELECTRO-PLATE MANUFACTURERS, AND ALL ENGAGED IN KINDRED BRANCHES OF INDUSTRY.

Member of the American Trade Press Association.

Our Editorial columns will contain our own opinions only, and we shall present in other columns only what we consider of interest or value to our readers. Advertising matter will not be printed as news.

Advertising rates in THE CIRCULAR are lower, considering the number of tradesmen reached by its large circulation, than in any other jewelry journal.

Notices of changes in standing advertisements must be received one week in advance; new matter can be received up to Monday.

## INFORMATION FOR SUBSCRIBERS.

### Terms of Subscription, Postage Prepaid.

United States and Canada, - - -	PER ANNUM.	\$2.00
Foreign Countries in Postal Union, - - -		4.00
Single Copies, - - - - -		.10

New Subscribers can commence at any time.

Payments for THE CIRCULAR when sent by mail, should be made in a Post-Office Money Order, Bank Check or Draft, or an Express Money Order or Registered Letter. All postmasters are required to register letters whenever requested to do so.

Pay money only to authorized collectors having proper credentials.

**Returning Copies** Returning your paper will not enable us to discontinue it, as we cannot find your name on our books unless your address is given.

**Changing Address.** In changing address always give the old as well as the new one. Your name cannot be found on our books unless this is done.

**Discontinuances.** We will continue to send papers until there is a specific order to stop, in connection with which all arrearages must be paid; but such an order can be given at any time, to take effect at or after the expiration of the subscription. All such orders will be promptly acknowledged by mail.

**Liability.** The Courts have decided that all subscribers to Journals are responsible until arrearages are paid in full and an order to discontinue has been received by the publisher.

## THE JEWELERS' CIRCULAR IN EUROPE.

Among the Places in Europe where THE JEWELERS' CIRCULAR is on file are the following:

**LONDON**—First Ave. Hotel, Holborn, E. C.; Holborn Viaduct Hotel, Royal Hotel.

**PARIS**—Hotel de L'Athéné, Rue Scribe.

**BERLIN**—Deutsche Uhrmacher Zeitung, Jager-Strasse, 73.

**GENEVA**—Journal Suisse D'Horlogerie.

**AMSTERDAM**—Contineental Club, Hotel Amstel.

**ANTWERP**—Diamond Club, Rue de Pelicaun.

Vol. XXXII. June 24, 1896. No. 21.

Every line of reading matter in THE JEWELERS' CIRCULAR, with the exception of the few brief extracts from exchanges, always properly credited, is written exclusively for this journal. Each issue of THE JEWELERS' CIRCULAR is copyrighted. Permission to quote is extended to other publications, if such quotations are properly credited.

### The Size of a Teaspoon.

A FEW physicians as well as one or two members of the medical press, are agitating the manufacture of uniform size teaspoons. The following is a copy of a letter that embodies the principal objections to the present state of affairs:

Editor of The Medical Record:

SIR:—I recently addressed a note to the Gorham Mfg. Co., silversmiths, of your city, directing attention to the wide variation in the capacity of teaspoons and asking if a pattern of uniform and definite capacity could not be adopted by the silversmiths of the country. This seems almost too much of a trifle to bring to the notice of your distinguished journal, but inasmuch as teaspoons are the universal standard, in domestic use, of measuring doses, and as they vary between the colonial spoon of one drachm and the modern spoon (tea) of two drachms, it might be of sufficient importance, as a matter of convenience to the profession, to invite some co-operation in an effort to obtain a teaspoon of standard capacity. It is manifestly unsafe, at present, to direct doses of a teaspoonful when there is so great a difference as a drachm in the contents. I have measured probably three hundred teaspoons during the past two years and have found that most of those of recent design hold one and one-half drachms, some two drachms, and none one drachm, excepting the very old and rare spoons.

D. E. WALKER, M. D.

ILLION, N. Y., May 18, 1896.

We are inclined to lock upon this movement as being in its origination one of those freaks of inquiry which take possession of isolated individuals who, carried away by the profundity of their discoveries, gradually evolve mountains from mole hills—in their own minds. Of course it would seem that the physician should measure the bowl of the spoon which is to be used in taking the medicine he prescribes, especially if a slight overdose of such medicines is deleterious in its effects upon the patient. However, as any movement, no matter howsoever trivial it may be (as Dr. Walker admits in his letter his movement is) directed against any condition that "menaces the public health," is likely ultimately to receive support, it may be well for the silversmiths to consider the matter at once.

### Opticians Organizing.

THE opticians throughout the country are at last apparently awakening to an appreciation of the need of an organization among them to serve as a bulwark against evils and dangers besetting them from not only without their field of activity but within its very confines. The Optical Society of the State of New York is firmly rooted, the Optical Society of Ohio is an established fact, and now the Opticians' Society of Pennsylvania is in the lists for the achieving of the following laudable objects: The elevation and advancement of the profession and the mutual intercourse and benefit of its members; to encourage opticians to perfect themselves in the study of optics and the scientific adaptation of lenses in correcting errors of refraction; to discourage the haphazard and indiscriminate sale of spectacles by irresponsible and ignorant persons.

### The Proposed Jobbers' Association.

In speaking of the proposed Jobbers' Association, Monday, J. H. Noyes said that many firms outside of New York, who had expressed themselves as against Mr. Root's plan after glancing over it, had changed their minds when the plan was explained to them, and were willing to give it their support. Nothing further, he said, had up till then been decided upon, but it was certain that the convention of jobbers would be called for July 15th, in New York.

### KANSAS CITY JOBBER'S WOULD ENDORSE A PRACTICAL SCHEME.

KANSAS CITY, Mo., June 18.—In regard to the proposed watch jobbers' association, it may be said that the jobbers of Kansas City are not specially in favor of it; in fact, only two firms expressed their willingness to join.

Herman Oppenheimer was a member of the old association and was one of the committee that presented the report that virtually killed it. Mr. Oppenheimer believes that a new association will be no better than the old, and that members will cut prices on the quiet; but if an association can be made to keep prices staple he would heartily endorse it.

Hugh Oppenheimer says the western jewelers need no association whatever, and that every jobber should look after his own individual territory and see that no one can undersell him.

Mr. Edwards, of Edwards & Sloane Jewelry Co., believes jewelers should look into all points before entering a new association, and that as to trying to have all jobbers sell to the legitimate jewelry trade only, he asserts that the trouble lies with the manufacturers, in their over production and desire to sell wherever they can.

M. Benjamin is in favor of a new association if carried out in all its intended details.

### THE MINNEAPOLIS JOBBER'S FAVOR AN ASSOCIATION.

MINNEAPOLIS, Minn., June 19.—The Minneapolis jobbers are all in favor of a new jobbers' association, if the organization will be binding and strong enough to control the sale of cases and movements, keep them in the proper channels of trade, and protect the jobbers in rebates. C. H. Carpenter, of the Minneapolis Jewelry Mfg. Co., stated that he had no argument to offer and that the new association would be a good thing for jobbers. Their firm will join the association. The Reed-Bennett Co. approve of the idea and remarked that they would become members of the organization if all conditions were favorable. S. H. Clausin & Co., who handle American watches extensively, will be on the side of the majority.

### J. H. NOYES TO VISIT PHILADELPHIA.

PHILADELPHIA, Pa., June 18.—J. H. Noyes will come to Philadelphia soon to urge members of the trade to unite in forming a National association in the interests of dealers in watches.

## New York Notes.

Alois Kohn & Co. have filed a judgment for \$1,139.34 against Morris Singer.

E. Kirstein's Sons Co. have filed a judgment against Mrs. J. E. Jarck for \$266.26.

L. S. Friedberger & Co. have entered a judgment for \$146.18 against Adolph Meyer.

Moritz Moos, 41 Maiden Lane, has given a chattel mortgage on office fixtures to Wallach & Schiele for \$2,088.

John B. Yates, of the John B. Yates Co., has been elected vice-president of the New York Bicycle Carnival Association.

The Sheriff last week received an attachment for \$3,421 against Albert H. Moore, Philadelphia, Pa., in favor of T. B. Starr, for jewelry.

Wm. I. Rosenfeld, 8 Maiden Lane, has rented the entire basement of the building, 174 Broadway and 1 Maiden Lane, which he has fitted up as a bicycle salesroom.

The European diamond market, said Simon Frankel, of Jos. Frankel's Sons, who returned last week, is still strong particularly in colored stones. Diamonds, he said, were scarce and business is good.

Secretary H. M. Condit, of the New York Jewelers' Board of Trade, visited Bridgeport, Conn., Friday, to investigate the failure of Breckbill & Benedict, of that city, and obtain for the creditors a report and statement of the condition of the insolvents' affairs.

Jacques Levy, who kept a jewelry and notion store at 1299 Broadway, made a hurried removal recently and his whereabouts could not be ascertained by a reporter who attempted to locate him. Levy removed his stock suddenly June 13th, leaving the store vacant. He has but few creditors in the jewelry trade.

An action against the 23 diamonds taken from James Baxter, of Montreal, when he was captured in Maiden Lane last March, was tried before Judge Brown and a jury, in the United States Circuit Court, Thursday. It was a suit *in rem* to declare the diamonds smuggled and subject to confiscation. No one appeared on behalf of the jewels and the jury brought in a verdict against the goods. They have been confiscated and will be sold at auction in due time.

In a dispatch published in a Newark paper of June 17th it was stated that Jno. B. McGrath, of Summit, N. J., had found a purse containing diamonds valued at several thousand dollars belonging to a salesman for Leopold Weil & Co., New York, to whom the stones were returned. At the office of Leopold Weil & Co., 51 Maiden Lane, a CIRCULAR reporter was told that no loss had been reported to them, but that the truth of the dispatch would be ascertained by an investigation.

The case of the Leroux jewelry seized by the United States for having been smuggled, commenced Thursday. It was conducted by the United States Marshall Hayden in the Circuit Court room in the Federal building. The final appraisal, made just before the sale, placed the total value of the jewelry at \$31,572.06. The amount realized Thursday was about \$8,500. Among the pieces which

brought the highest bids were some loose diamonds which sold for \$230, and three watches which were disposed of at \$167.50, \$182.50, and \$150.

## A Call from the New York Optical Society.

The Optical Society of the State of New York have issued the following call to the trade:

### A CALL TO OPTICIANS.

At the Society's meeting recently held in Syracuse on June 2nd, in executive session, a resolution was passed authorizing the publication of the first draft of the Constitution and By-laws of the society. This was done in view of the fact that, although the society has issued abundant literature setting forth its loyalty to the interests of opticians, the officers have been repeatedly applied to for copies of the Constitution and By-laws; many opticians claiming that they could not consistently join the Society without first being made familiar with the document.

It is now to be hoped that every optician who has an interest in his future, and who intends to remain in business in this State, will without procrastination, make application to the secretary.

The opticians of the State, who remain indifferent to the Society, cannot expect to have their interests protected by it. The future agitation for legislation remedying existing evils can only result favorably to the interest of those who promote it, whereas indifference on the part of others must be accepted by the Society as an acknowledgement that they desire no consideration or protection of their business interests.

The Society's legislative bill will be revised accordingly, and unless a greater interest is manifested by the opticians of the State, many of them may find themselves in the unfortunate position of those who are now being menaced by the medical bill, which was passed in Ohio on Feb. 27th, 1896.

The optician who cannot defend himself is very short sighted indeed not to avail himself of the opportunity to have others do it for him, particularly when the chance is offered him on such easy terms. Between now and October the opportunity is open to every optician of good standing in this State to join the Society, on payment of the annual dues only. The opticians then in the Society as members will decide its future legislative policy at the meeting to be held in October next. Should its decision result unfavorably to those who are not members, it is evident that they will have no one to blame but themselves. Delinquent opticians should therefore at once apply to the secretary for membership-blanks.

H. W. APPLETON, *Secretary.*

By order Executive Committee.

President Chas. F. Prentice has appointed H. W. Appleton as secretary of the Society, and to fill the unexpired term of the office made vacant by the former secretary's resignation on June 2.

H. L. Baker, Bluffton, has on exhibition a tiny gold engine that is probably the smallest working engine and boiler in the world. The inside of the cylinder measures  $1\frac{1}{2}$  by  $2\frac{1}{2}$  millimeters. The stroke of the piston is but two millimeters and the smallest screw is four one-thousandths of an inch. The stem valve is two one-thousandths of an inch and the engine, if placed upright, will hardly cover the end of an unsharpened lead pencil. A drop of water fills the boiler. Mr. Baker worked two years at odd hours making the machine.

## Death of Mark O. Wheaton.

ATTLEBORO, MASS., June 21, — Mark O. Wheaton, of Wheaton, Richards & Co., manufacturing jewelers, died to-day, of rheumatic fever, at the age of 64 years. Mr. Wheaton was a member of the State Legislature, a Grand Army veteran and prominent in all local affairs.

## Providence.

A meeting of the creditors of Wood, Bicknell & Potter who recently made an assignment to attorney James M. Scott, was held last Tuesday afternoon in the office of Lorin M. Cook. There were creditors present representing \$38,000. The only business transaction was the selection of Mr. Scott as permanent assignee.

Thomas Trimble, a former employe of J. A. Foster & Co., who was indicted on a charge of stealing a variety of articles from Foster's store, retracted his former plea of not guilty and Wednesday morning pleaded *nolo contendere*. The articles stolen included a watch, sheets of gold foil, diamonds, jewelry and a considerable sum of money in small change. All of the goods have since been returned, and Trimble's lawyer pleaded for leniency on the part of the court, as the prisoner had a wife and three children dependent upon him. Judge Wilbur imposed a fine of \$150 and costs without imprisonment.

## Trans-Atlantic Voyagers.

### TO EUROPE.

W. N. Le Cato, manager of the retail department of the Gorham Mfg. Co., New York, and W. C. Codman, superintendent of the factory in Providence, R. I., sailed for Europe June 17th on the *New York*.

Mr. and Mrs. L. Bonet, New York, sailed on the *La Gascoigne*.

Geo. L. Fox, of M. Fox & Co., New York, and H. Van Slochem, New York, sailed on the *Campania*.

### FROM EUROPE.

Jacob Muhr, of J. Muhr & Bro., Philadelphia, Pa., sailed for home on the *St. Paul* from Southampton, June 20th.

Among the passengers who arrived on the *Fuerst Bismarck*, Friday, were Simon Frankel, of Jos. Frankel's Sons, New York; Albert Krower, of Albert Lorsch & Co., New York, and M. Straus, Brooklyn, N. Y.

## THE RING GIVEN TO PRESIDENT FRANKLIN PIERCE.

SAN FRANCISCO, June 16, 1896.

Editor of THE JEWELERS' CIRCULAR:

Noticing under the heading of "The Connoisseur" an item relative to the ring given to Franklin Pierce by the citizens of California, would call your attention to a slight error in regard thereto.

The ring was made by me, and did not "weigh over half a pound." It was presented by several citizens of Sacramento and contained some of the best specimens of ore ever taken from the State.

Very respectfully,  
A. ANDREWS.

## Special Notices.

Rates 75c. per insertion for notices not exceeding 3 lines (25 words); additional words 2 cents each. If answers are to be forwarded, postage stamps must be enclosed. Two insertions, 15 per cent. off; three insertions, 20 per cent. off; four insertions or more, 25 per cent. off. Payable strictly in advance. Display cards on this page will be charged at \$2.00 per inch for first insertion, subject to same discount as above for subsequent insertions.

Under the heading of **Situations Wanted** on this page advertisements will be inserted for **One Cent a Word** each insertion, no discount. This offer refers to **Situations Wanted only**. Payable strictly in advance. If answers are to be forwarded, postage must be enclosed.

## Situations Wanted.

*Notices under this heading ONLY are charged at one cent a word, payable strictly in advance. If answer are to be forwarded, postage must be enclosed.*

**SALESMAN**, ten years with Tiffany & Co., and five years with Gorham Mfg. Co., desires position; refers to above firms; fall or sooner if possible. B. S. M., care JEWELERS' CIRCULAR.

**POSITION** by young man 24 years of age, several years' experience in jewelry business; salesman and general repairer; open until Sept. 15th; sober and practical; best of references. Address W. B. W., care JEWELERS' CIRCULAR.

**FIRST-CLASS WATCHMAKER** and optician desires permanent situation with reliable house; 28 years' experience; capable of taking charge of store; own tools and trial case. Address C. F. Baldwin, 404 Main St., Keokuk, Ia.

**SITUATION WANTED** as a watchmaker's assistant, salesman, etc.; can repair watches, clocks, jewelry and engrave coffin plates; is of sober, industrious habits, honest and faithful; A1 references. Address H. M. Stansbury, Pawtucket, R. I.

**I HAVE A YOUNG MAN** in my employ who is worth more than I can afford to pay; I would like to get him a permanent position; he is a good watch and clock maker and jewelry repairer, and good habits. Address Lock Box 894, Lyons, N. Y.

**TRAVELING SALESMAN** of 15 years' experience with established trade in Illinois, Michigan, Minnesota and Wisconsin, will negotiate with good manufacturer or jobber of jewelry to carry their line on salary or commission; best of references. Address E. M. B., care JEWELERS' CIRCULAR.

## Help Wanted.

**LAPIDARY WANTED.**—None but a thorough workman, who can furnish unquestioned references need apply. 5 Dutch St., N. Y. Top floor.

**WANTED.**—Experienced traveling salesman to handle best American line of spectacles through New York State and the East. Address Optics, care JEWELERS' CIRCULAR.

**WANTED.**—A traveling man for Nebraska, Iowa, Missouri and Minnesota; new jewelry firm; has established trade; a fine line, and carries everything needed by jewelers; by Aug. 1st; state experience, etc. O. N., care JEWELERS' CIRCULAR.

## Business Opportunities.

**MUST SELL;** large town, competition light. will reduce to suit; stock, etc., now about \$3,000, going at a bargain. Address G. H., care JEWELERS' CIRCULAR.

**\$1,200** will buy my 6,800 lb. steel-lined safe, plate glass store fixtures and balance of my clocks and silverware; will sell watches and jewelry if wanted; best opening in Oklahoma for a five jeweler. Chas. E. Rose, El Reno, Oklahoma.

**FOR SALE** in Philadelphia, a desirable business in a fine locality; clean stock about \$8,000, which can be reduced if desired; walnut fixtures, fine regulator, safes, etc.; good run of work; established 12 years. Address O. E., care JEWELERS' CIRCULAR.

**\$650.00 SPOT CASH** buys fixtures, material and optical goods of leading jewelry and optical store; established 15 years; western New York; bench work \$1,500 per year; only optician; will sell any other part of stock if desired. Address J. O., care JEWELERS' CIRCULAR.

**FOR SALE**, in Spencer, Mass., midway between Springfield and Boston, an old established jewelry store with little competition; about 8,000 inhabitants, in a pleasant manufacturing town; good stock, fine regulator, worth \$300; steel lined large safe, etc.; stock and fixtures inventoried last March at \$5,800; rent of store, \$2.00 per year; lighted with gas, and has running water; store can be bought for sixty cents on the dollar, for cash or good security; a good chance for a young man. Address E. F. Sibley, Spencer, Mass.

## To Let.

**TO LET**—A good office on the third floor in the Diamond Exchange Building, 14 Maiden Lane, N. Y.; now occupied by the Fletcher Watch and Jewelry Co. This office will be rented very low to May 1, 1897. Apply to Janitor, or Smith & North, 14 Maiden Lane, N. Y.

## For Sale.

**FOR SALE.**—Crouch & Fitzgerald trunk and three leather sample cases, watch trays, etc. Address B. C., care JEWELERS' CIRCULAR.

**FOR SALE.**—A Marvin fire-proof safe; outside width 54 inches, height 65 inches, depth 28 inches. R. A. Loveland, 177 Broadway, N. Y.

**FOR SALE, CHEAP**, two wall cases, each 25 feet long, 18 inches deep, 9 feet high; solid walnut, slide up doors, closets below, moveable shelves; cost \$1,000, sell for \$275. R. C. Green & Son, Pottsville, Pa.

## Miscellaneous.

**SILVERSMITHS AND JEWELERS** wishing designing or modelling done outside by artist of large experience in that line, please address N. W., care JEWELERS' CIRCULAR.

## FOR RENT.

Large Office, 5th Floor - - **Corbin Building.**

Will let very low for  
Three Years.

APPLY, - - - -

**JOSEPH FAHYS & CO.,**  
NO. 54 MAIDEN LANE, N. Y.

## FOR SALE.

Two Fine Black Walnut Wall Cases, twelve feet long. Two twenty-four feet long. One twenty-five feet long. These cases have vertical sliding doors, and were made by B. & W. B. Smith, and are in perfect condition.

**REED & BARTON,**  
37 Union Square, New York.

**BOOKS**

— FOR —

**JEWELERS.**



**THE**  
**JEWELERS' CIRCULAR**  
**PUB. CO.**

189 BROADWAY, N. Y.

## Send for New Catalogue of 200 Books

pertaining to the Jewelry, Watchmaking, Assaying, Engraving, Optical and Kindred lines, published or for sale by the Jewelers' Circular Publishing Co. The only complete Catalogue published for these trades.

Sent Free upon Application.

The Jewelers' Circular Pub. Co.,  
189 BROADWAY, N. Y.

**F** YOU WANT A POSITION  
YOU NEED A SALESMAN  
YOU NEED A WORKMAN  
YOU DESIRE TO EXCHANGE  
YOU WANT A PARTNER  
YOU WISH TO SELL OUT  
YOU HAVE TOOLS TO SELL  
YOU HAVE A PLACE TO LET  
YOU WANT ANYTHING

USE THE  
**SPECIAL NOTICE PAGE**  
OF THE

**JEWELERS' CIRCULAR,**

Published Every Wednesday.

## Our Traveling Representatives



Traveling representatives may consider these columns open for the publication of any news or items of interest regarding themselves or their confreres.

**T**RAVELING representatives in Indianapolis last week included: E. I. Rogers; Parks Bros. & Rogers; Chas. Marsh, C. A. Marsh & Co.; F. N. Vaslett, Fletcher, Burrows & Co.; C. Vaslett, Thornton Bros.; Mr. Pelletreau, R. Blackinton & Co.; Sol. Caro, Marble, Smith & Forrester, J. T. Inman & Co., and James Bergman.

Eastern jobbers and manufacturers represented in the Twin Cities the past week were: Waite, Thresher Co., by Mr. Mumford; S. & B. Lederer, by G. Rodenberg; Providence Stock Co., by Mr. Jacoby; Meriden Britannia Co., by W. C. Wood.

Among travelers in St. Louis, Mo., last week were: Herbert W. Van Houten for C. Sydney Smith; F. R. Horton, Carter, Hastings & Howe; Lewis E. Fay, Kirby, Mowry & Co.; C. B. Bartlett, Whiting Mfg. Co.; A. Kingsland, Reeves & Sillocks; Clarence Pettit, Hayden Mfg. Co.; Howard Rowbotham, J. Muhr & Bro.

Among the traveling men in Philadelphia, Pa., the past week were: George W. Wagoner, the Whiting Mfg. Co.; A. Rutherford, Kirby, Mowry & Co. F. R. Krugler, H. H. Curtis & Co.; M. Hopkins, Meriden Silver Plate Co.; Mr. Lewis, S. M. Lewis & Co.; Mr. Middleton, Gorham Mfg. Co.; P. Tommins, Middletown Plate Co.

The travelers in Kansas City, Mo., last week were: C. F. Couts, E. G. Webster & Son; Edgar L. Brown, Riker Bros.; M. Gregory, Strobell & Crane; A. J. Sherrard, Enos Richardson & Co.; W. T. Willis, Gorham Mfg. Co.; M. Wilmot, Bauman-Massa Jewelry Co.; W. L. Mason, Hayden W. Wheeler & Co.; H. H. Bradley, E. A. Bliss Co.; F. R. Horton.

The Jewelry Travelers' Association of New England will hold their sixth annual mid-summer outing and banquet at the Relay House, Bass Point, Nahant, Saturday, July 11. The feature of the outing will be an old-time shore dinner with all the frills and fixings. A sail from Boston to Nahant in one of the harbor excursion boats will be a pleasant appetizer for the dinner.

Traveling men in Boston, Mass., the past week included: S. F. McClannin, Kent & Stanley Co., Ltd.; A. A. Wood, Howard Sterling Co.; Mr. Cary, J. B. & S. M. Knowles Co.; Ed. Eckfeldt, Eckfeldt & Ackley; Herbert Barker, J. W. Reddall & Co.; Frank Wood, Carter, Hastings & Howe; W. D. Elcox, Larter, Elcox & Co.; A. L. Stearns, Roy Watch Case Co.; A. W. Atwater, Brooklyn Watch Case Co.

The jewelry traveling man was an exceed-

ingly scarce article in Syracuse, N. Y., the past week, the few specimens discovered being: George B. Osborne, Wm. Smith & Co.; Col. John Shepherd, Keystone Watch Case Co.; Charles Barber, Gorham Mfg. Co.; S. D. McChesney, William B. Kerr & Co.; Mr. Gregory, Strobell & Crane; F. C. Klein, for A. Wittnauer.

The following traveling salesmen passed through Detroit, Mich., last week: Charles B. Bartlett, Whiting Mfg. Co.; Harry Osborne, Howard Sterling Co.; George Bleecker, The Bassett Jewelry Co.; H. A. Bliss, Krementz & Co.; James H. Donnelly, The Alvin Mfg. Co.; A. Kingsland, Reeves & Sillocks; Mr. Gregory, Strobell & Crane; Mr. Parker, Osmun-Parker Mfg. Co.; Walter Shute, Day, Clark & Co.; L. E. Smith, M. B. Bryant & Co.; Charles F. Ketcham, Riker Brothers; Will H. Maire, the Dueber Watch Case Mfg. Co.; Mr. Sinnock, Ehrlich & Sinnock; Mr. Rogers, Park Bros. & Rogers; Mr. Bigney, S. O. Bigney & Co.; Mr. Wexel, Wexel & Co.; and Mr. Levy, for Adolphe Schwob.

Among the travelers who registered in Pittsburgh, Pa., last week were: L. E. Smith, M. B. Bryant & Co., and a participant in the late St. Louis cyclone (not the convention); H. B. Richardson, G. A. Dean & Co.; Herbert W. Van Houten, for C. Sydney Smith; C. A. Marsh, C. A. Marsh & Co.; S. Sichel, Eichberg & Co.; Mr. Steere, Arnold & Steere; Mr. Kennon, J. T. Maura Mfg. Co.; J. Beattey, S. E. Champlin & Son; Mr. Gregory, Strobell & Crane; J. D. Underwood, Champenois & Co.; Lewis P. Cook, J. F. Fradley & Co.; L. V. Benson, LaPierre Mfg. Co.; J. Fred. Crane, Mandeville, Carrow & Crane; Mr. Parker, Osmun-Parker Mfg. Co.; Clarence Pettit, Hayden Mfg. Co.

### Boston.

W. B. Durgin, Concord, N. H., was among the visitors in town last week.

Mrs. Nelson H. Brown has returned from her outing in California.

E. V. Clergue, New York representative of the E. Howard Watch & Clock Co., was in Boston the past week.

H. W. Holbrook & Co. have been succeeded by the Bentley Jewelry Co. Mr. Holbrook retires and T. B. Bentley, of the firm, continues as head of the business.

The requisition from Troy, N. Y., for Henry B. Lowery, for the alleged larceny of diamonds from a jeweler of that city, has been honored by the court here, and Lowery has been taken to New York State to stand trial.

Garibaldi & Bruns, Charlotte, N. C., have been in town the past week stocking up for their new store in that place. While in this section they have been the guests of George T. Howard, of the Towle Mfg. Co., Newburyport.

The E. Howard Watch & Clock Co. will close the watch factory for a two weeks' vacation in August. Business in the bicycle department is so brisk, however, that there may be no shut-down of that part of the establishment.

Last Thursday evening two men worked the

ring substitution game in the store of Edwin Ruben, 31 Green St., securing a diamond ring valued at \$115. One of the pair engaged the jeweler's attention with a request to be shown some watches while the other was performing the sleight-of-hand trick with the rings.

### Philadelphia.

The contract for making the silver service for the battleship *Iowa* has been awarded to J. A. Caldwell & Co., of this city. The service is to cost \$5,000. It is composed of 40 pieces, weighing 1,970 ounces.

The members of the Union Republican Club, who left for St. Louis June 13th, were presented with a pretty souvenir by the firm of Simons, Bro. & Co. The gifts were badges to be worn at the convention. At the top was the spread eagle in sterling silver on a pin of the same material, while from this hung a miniature American flag of silver.

### Pittsburgh.

A. E. Siedle sold real estate on Collins Ave., E. E., for \$4,125.

Wallace Optical Co. have improved their building, 624 Penn Ave.

The American Watch Co. have opened a new office at 1,723 Fifth Ave.

The store of Leo G. Weil, 428 Smithfield St., was closed by the constable on a landlord's warrant, June 18.

Chas. O'Brien, lately traveler for Goddard, Hill & Co., now with C. C. Corcoran, Wood St., will become a benedict this week.

Visiting jewelers last week included: George V. Brady, Washington, Pa.; E. H. Kennerdell, Tarentum, Pa.; John Linnenbrink, Rochester, Pa.; Mr. Hunt, Uniontown, Pa.

A unique window display is that of R. Siedle & Sons, which represents a lilliputian wedding party. The central figures are a doll bride, bridegroom, and minister, arrayed in regulation bridal attire. Above the heads of the party is a sign which reads, "We sell the rings for this ceremony." It is needless to state that the window attracts.

### Louisville.

Mr. Boegerhausen will close out his stock and deal exclusively in tools and materials.

James H. Kelsey, Middletown Plate Co., was here last week to attend the Knights of Honor Convention and to call on the jewelers.

Salesmen calling on the Louisville trade last week were: A. J. Sherrard, Enos Richardson Co.; Jacob Marx, Kossuth Marx Jewelry Co.; E. H. Pelletreau, Shafer & Douglas; J. C. Miller, H. Keck Mfg. Co.; Mr. Hamilton, Meriden Bronze Co.; and Mr. Kingsland, Reeves & Sillocks.

A. Steffanoni has given a bill of sale of his jewelry store in Oakland, Cal., to H. R. Davis.

Gen. Geo. H. Ford was Grand Marshal June 17, of the procession in New Haven, Conn., which marched to the Ancient Cemetery and decorated the graves of Revolutionary soldiers and of Roger Sherman.

## Queries by Circular Readers.

**NOTE.**—Questions under this department will be answered as promptly as possible. Some queries require careful investigation before a satisfactory answer can be given; hence such answers are often seemingly delayed. **THE CIRCULAR** desires every jeweler to take advantage of this department.

CHICAGO, Ill., April 28, 1896.

Editor of THE JEWELERS' CIRCULAR:

Will you kindly inform us, if possible, the name of the manufacturer who uses the trade mark illustrated below.



One of our customers has inquired for a spoon pattern named "Celine," which she claims has this trade mark upon it, and as a matter of business education we should like to know who made it. Thanking you in advance, we remain,

Very truly yours,

TOWLE MFG. CO.

**ANSWER:**—We infer that the pattern is that of Frank W. Smith, Gardiner, Mass. He manufactures a pattern called "Cellini," and in a piece in this pattern which we have seen, the mark stamped in it resembles the drawing above, although in reality it is as follows:



We think that the pattern which your customer desired is really the "Cellini," which as commonly pronounced might be spelt "Celine." The Gorham Mfg. Co. also have a "Cellini" pattern.

PENN YAN, N. Y., June 15, 1896.

Editor of THE JEWELERS' CIRCULAR:

Mr. E. H. Hopkins of this place gives me your address. I wish the addresses of persons who deal in all kinds of pearls, especially those from fresh water mussels. A party in Florida has sent me a lot she took while obtaining the shells for me, and wants me to find a purchaser for them. Mr. Hopkins says he has seen such advertisers' "ads." in your paper but looked in vain for them the other day. If such parties have advertised with you in the past, I hope you will kindly refer me to them and greatly oblige.

Yours truly,

B. H. WRIGHT.

**ANSWER:**—Among the dealers who buy American pearls are: Randel, Baremore & Billings, Maiden Lane and Nassau St., New York; Lassner & Nordlinger, 68 Nassau St., New York; E. Karelson & Co., 68 Nassau St., New York; S. Lyons & Son, 68 Nassau St., New York; J. Frankel's Sons, 68 Nassau St., New York.

WILLIAMSPORT, Pa., June 13, 1896.

Editor of THE JEWELERS' CIRCULAR:

Please send us the address of the importers of the Jules Jurgensen watches, in your city.

BLACK & Co.

**ANSWER:**—Schulz & Rudolph, 28 John St. and 65 Nassau St., New York, are sole agents in America for the Jules Jurgensen watches.

ONEIDA, N. Y., June 15, 1896.

Editor of THE JEWELERS' CIRCULAR:

Will you kindly send us the address of the Jewelers' Board of Trade of your city and oblige.

ONEIDA SPECIALTIES CO.

**ANSWER:**—The address of the New York Jewelers' Board of Trade is Sheldon building, 68 Nassau St., New York.

## Connecticut.

Henry Harris, Hartford, has begun a daily closing out sale at auction. He says he is obliged to go out of business as his health is failing by continuous confinement in the store.

Sheriff W. A. Booth served a writ of attachment last week on the stock in Linus H. Hill's jewelry store, Wallingford, in the interest of Benjamin H. Wooding. The attachment is returnable before Justice H. W. Andrews on June 25.

P. H. Stevens, the Bristol jeweler, has assumed entire control of the jewelry business at 7 N. Main St., and the firm name will be P. H. Stevens, instead of P. H. Stevens & Co. The store has been under Mr. Stevens' active management since its inception.

Judge Andrew rendered his decision in the case of jeweler M. C. Le Witt, New Britain, which he has withheld for two weeks. He finds probable cause in the case and returns the defendant for trial at the September term of the Superior Court. Bonds were fixed at \$500.

M. Greenberg, who has conducted a jewelry store at 222 E. Main St., Bridgeport, has left the city to seek other fields. Business has been very poor of late and he decided to leave town. A number of watches which had been left for repair have also departed. Mr. Greenberg shipped his goods to New York.

The New Haven Clock Co.'s shop shut down June 16, for an indefinite period and over 500 employes of the company are out of work. Walter Camp, secretary of the company, states that the shut-down was not an unusual thing.

He says that each year the company are obliged to suspend operation for a short time on account of the dulness of the trade. He says that the time for the shut-down this year is a little earlier than usual because the dull season commenced earlier than in former years.

## His Silver Mug

"DO you want any tin cups to-day?" asked a salesman in a big Chestnut St. jewelry store of a customer. The latter laughed and said: "No. I've had the last one I got from you for three years."

When the last speaker had gone out, the salesman turned to another customer and remarked: "There's a funny thing. That man who just left is the proprietor of a big hotel down at Atlantic City. He has a passion for silverware and always keeps a solid silver cup at the big ice cooler in the office. Some people can't resist the temptation to steal a handsome silver mug when it comes in their way with nobody in sight. So for a time the hotel proprietor was kept busy buying silver mugs. He used to lose one about every two months, and yet he wouldn't give up the fad. Finally he hit upon a happy expedient. He had us make him a cup of solid silver, built upon the model of the ordinary tin cup, such as one finds at drinking fountains in the park. The deception was so clever that no one thought it worth his while to steal this cup, and it has been in use for three years."—*Philadelphia Record.*

## A. WITTAUER,

SUCCESSOR TO

J. EUGENE ROBERT & CO.,

IMPORTER AND MANUFACTURER OF  
PLAIN AND COMPLICATED

WATCHES AND

WATCH MOVEMENTS,

19 Maiden Lane, New York.

# OPPENHEIMER BROS. & VEITH,

CUTTERS OF DIAMONDS,

DEALERS IN WATCHES,

65 NASSAU STREET (PRESCOTT BUILDING), NEW YORK.

THE STAR OF EMPIRE WESTWARD TAKES ITS WAY!

# WESTERN SUPPLEMENT

## OF THE JEWELERS' CIRCULAR

VOL. XXXII.

CHICAGO, WEDNESDAY, JUNE 24, 1896.

NO. 21\*

### Chicago Notes.

*All communications in reference to the Chicago department of The Jewelers' Circular, addressed to S. Parlin, 1527 Wrightwood Ave., Chicago, will receive immediate attention.*

M. Benjamin, Kansas City, Mo., was in this city last week.

Most of the travelers from Chicago are in from their early trips.

John B. Eberhardt, South Chicago, is away on a few weeks' pleasure trip.

Philip Muhr, of J. Muhr & Bro., Philadelphia, Pa., is expected in Chicago shortly.

W. F. Adams, Simpson, Hall, Miller & Co., in on a six weeks' vacation, visiting his parents in Boston.

The jobbing houses are busy with catalogue work, though with many the work is nearly completed.

E. A. Dorrance, Simon, Bro. & Co., returned from his outing at his cottage at Antioch, Ill., and went east Friday on business.

H. C. Wilson, Crescent Watch Case Co., is spending this week with jobbers in Cincinnati, Indianapolis, St. Louis and Kansas City.

Stocktaking has made the week a busy one for Lapp & Flershem and H. F. Hahn & Co. Both firms report stocks in excellent condition.

George Gubbins, for the Courvoisier-Wilcox Mfg. Co., is showing the Essex and Courvoisier-Wilcox lines of cases in cities in the central west.

"Business has been pretty good," reports Manager Midlen, of the Gorham Mfg. Co. "The month so far has exceeded the earlier expectations."

Ed. Hoffman, the popular traveler for F. C. Happel Co., was married at his home in Ohio, Thursday, the 18th. Mr. and Mrs. Hoffman will reside in Chicago.

The salesrooms of the Towle Mfg. Co., 149-151 State St., have been entirely redecorated the past two weeks, and present a most attractive and inviting appearance.

T. J. Dale, whose home was formerly in Elgin, Ill., has started a new store in Kenosha, Wis., buying his first stock the past week. Mr. Dale is a practical watchmaker.

Stephen Holland, manager of credits for B. F. Norris, Alister & Co., is enjoying himself with rod and line at Vicksburg, Mich., the first vacation he has taken in 15 years.

Harry Hansell, for a long time a prominent figure in the salesrooms of B. F. Norris, Alister & Co., has established an office with a

general line of jewelry on the 8th floor, Columbus Memorial building.

O. W. Wallis & Co. have incorporated with a capital stock of \$10,000 in single shares of \$100, to "buy and sell watches, clocks, jewelry and other goods and merchandise." Obed W. Wallis, Traiton W. Wallis and Oscar N. Norine are the promoters.

The engagement is announced of Miss Cecile Young, eldest daughter of Otto Young, and Lawrence Heyworth, a college bred man of one of our leading families, and a prominent society leader in the younger circles. The wedding will be solemnized some time during the coming Winter.

J. F. Kiser, formerly of the wholesale jewelry firm of Kiser & Solether, Fostoria, O., has formed the firm of Kiser Bros., Muncie, Ind., for the manufacture of both flat and hollow silver ware. The firm have a large and well equipped plating plant at the corner of Hoyt Ave. and Liberty St., with prospects of good business in the future.

Manager Barnes, Holmes & Edwards Silver Co., recently returned from the factory, reports that the company have three new patterns of flatware in general lines. The "Liberty" and the "Irving" are now on the market, and the "Lincoln" will be out in time for Fall trade. All three are scroll designs and are handsome and attractive patterns. The Chicago house reports that their trade is better than a year ago, which, in turn, was better than the trade the previous year.

### Indianapolis.

F. P. Herron and wife have returned from a trip to Shelbyville, Ind.

A cablegram from E. C. Miller announced his safe arrival across the Atlantic.

Several retail jewelers are handling bicycle lanterns, but the trade in wheels is considered over for this season.

John Gardner, of Gardner & Ross, has sent his card to the Indiana jewelers asking them to expect a visit from him about July 15th.

John Wimmer has completed some repairs and improvements in his rooms and now has one of the most complete optical establishments in the west.

Jewelers have settled down to Summer quiet, and are not looking for much more trade until September. Belts still hold front rank as ready sellers.

Local travelers are out on their last trips for the season. Chas. W. Lauer, for Heaton, Sims & Co., and D. J. Reagan, for Baldwin, Miller & Co., are working in from Illinois.

### Detroit.

A. T. Selkirk, jeweler, Charlotte, Mich., has removed to new quarters.

Charles Hammond, of Smith, Sturgeon & Co., has returned from a trip to Europe.

R. Breitenbecher, for many years at the corner of Farrer and Bates Sts., has removed to 78 Gratiot Ave.

The model of the \$75,000 Hahnemann monument to be erected in Washington, was on exhibition at Roehm & Sons last week. It was brought here for the purpose of being shown to the Materia Medica Institute of Homoeopathy, which met here.

The silverware to be used in the New Harrington Hotel, Port Huron, Mich., will be manufactured by Reed & Barton, and furnished through the firm of R. S. & J. D. Patterson. The service was on exhibition in that firm's windows last week.

### Minneapolis and St. Paul.

F. W. Terhune, Barron, Wis., has sold out his business to G. Gabriel.

The Minneapolis Jewelry Mfg. Co. are adding a gold, silver, and nickel plating department to their establishment.

The business of A. H. Schleuder, New Ulm, Minn., who died a short time ago, will be continued by his son, Herman Schleuder.

Out-of-town jewelers visiting the Twin Cities the past week were: A. Mealey, Delano, Minn.; John Wasalie, Vaconia, Minn.; G. Gabriel, Barron, Wis.

E. H. Murdock, Minneapolis, has been appointed official photographer of the Great Northern Railroad, and has started out on a trip from this city to the coast taking views along the route for the company.

E. N. Marshall has gone out of the jewelry business in Midland, Tex.

The jewelry store of L. W. Keil, Lamar, Col., was destroyed by fire lately.

C. E. Van Voorhees has made an assignment of his jewelry store in Monette, Mo.

Attachments amounting to \$3,000 have been filed against Wm. Friedlander, Portland, Ore.

J. M. Bricker, Nevada, Ia., has given chattel mortgages on his jewelry store amounting to \$101.



**Pacific Coast Notes.**

S. J. Smith, jeweler, has located in La Porte, Cal.

Irwin Runyeon, Redlands, Cal., is selling out his stock.

Chas. Haas & Son, Stockton, Cal., are building an elegant new front to their store.

C. H. Steinmetz has leased a building in Suisun, Cal., and will open a jewelry store.

James E. Schenck, the Elsinore, Cal. jeweler, has been appointed postmaster at that place.

Albert Hansen has returned home to Seattle, Wash., after an extended visit to the principal points in California.

M. German, A. V. Travis, and M. E. Clark, all of San Diego, Cal., have opened a jewelry store at Prescott, Ariz.

A conditional bill of sale has been filed by J. E. Sancier, Rossland, the booming mining camp in British Columbia.

The store of D. O. Rideout, Draper, Utah, was robbed some nights ago, 12 watches and a small amount of cash being taken.

L. C. Henrichsen, Portland, Ore., has been sued for \$1,603, the result of his recent assignment to the Commercial National Bank.

A. B. Crawford, jeweler, Flagstaff, Ariz., went to Chicago and was married on May 28th to Miss Annie I. Howard, of Turner's Falls, Mass.

Considerable damage was done to the fine jewelry stock of A. J. Thomas, Missoula, Mont., recently, by a breakage in the water pipe located over the store.

Pacific Coast jewelers say that while business is dull, the indications are favorable. Trade in the northwest is reviving and money is easier in San Francisco.

Harry Rawson, jeweler, Moscow, Idaho, has added to his establishment a large stock of crockery, lamps and china ware formerly owned by McGuire & Brown.

Realty was conveyed recently by the following jewelers of the northwest: Harry Rawson, Moscow, Idaho, \$300; J. S. Luckey, Eugene, Ore., \$1; Elie Ritchott, Wallace, Idaho, \$125.

**Kansas City.**

J. L. Tracey, Liberty, Mo., was married last week to Miss McDaniels.

J. C. Dueber, Canton, O., was in Kansas City several days last week, making the acquaintance of local dealers.

Fire in Howe City, Kan., last week, destroyed the store of S. S. Skadden. Most of

his goods were saved and the loss is fully covered by insurance.

H. Stephens, 924 Main St., was robbed of a quantity of watches and jewelry. Frank Williams has been captured and is held on suspicion of being the thief.

Among the out-of-town buyers here last week were J. J. Stott, Paola, Kan.; Amos Plank, Hutchinson, Kan.; Otto Burklund, Osawatomie, Kan.; L. Megede, Richmond, Mo.; Sol. Marks, Lawrence, Kan.; C. E. Wardin, Topeka, Kan.; S. J. Huey, Excelsior Springs, Mo.

A two-leaf folder entitled "Come Ye Disconsolate," contains the following rhymes in reference to the Swan fountain pen, patented by W. W. Stewart and manufactured by Mabie, Todd & Bard, New York:

Brace up! this is the season of smiles and flowers.  
 When nature is doing her very best,  
 Combining genial sunshine with grateful showers  
 To make mossy slopes on which we rest.  
 If you cannot afford a bicycle  
 Then patronize the trolley,  
 Don't become an icicle  
 And preach of expense and folly.  
 But buy a Swan Fountain Pen,  
 Make notes of all that you may see  
 When visiting some cozy-nook or gien;  
 Or sketch an inspiration, with fancy free,  
 Nature the beautiful does to you appeal,  
 And appetite will rejoice at even a crust,  
 So don't feel badly for the want of a wheel,  
 Resolve to have a Swan Fountain Pen, or bust.

—W. W. STEWART.

**THE PERFECTION SHOW CASE**

FOR FINE JEWELRY TRADE.

WE CHALLENGE THE WORLD TO PRODUCE ITS EQUAL.

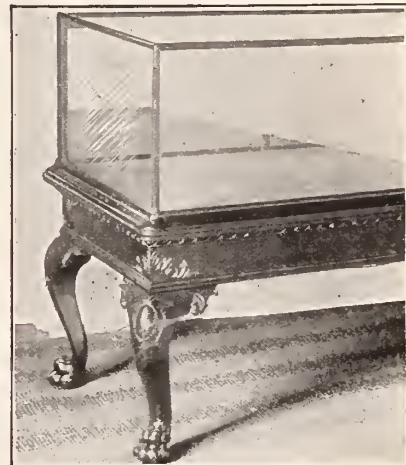

IF YOU ARE INTERESTED IN SHOW CASES AND JEWELRY FURNITURE, WRITE US FOR FULL INFORMATION.

**A. H. REVELL & CO.,**

431 to 437 Fifth Avenue, Chicago.

**AUSTRALIAN OPALS**

IN THE ROUGH. TRADE ONLY

ARTHUR F. CATE,  
 1125 WALNUT ST., - - DES MOINES, IOWA, U. S. A.

**PARSONS & SCHOOL**

—FOR—  
**WATCHMAKERS,**  
 PEORIA, - - - - - ILL.  
 Send for Circular and Terms  
**PARSONS & CO.**

**ELGIN KING**  
**\$100.00 BICYCLES**  
 ARE  
**SWIFT, STRONG,**  
**LIGHT AND HANDSOME.**  
 None better in any respect  
 Write for Catalogue and Agents' Terms.  
 Send 10 Cents for Elgin King Scarf Pin.  
 Address Department B,  
**ELGIN CYCLE CO.,**  
 ELGIN, ILL.

**COLONIAL.**

STERLING SILVER.

**TOWLE MANUFACTURING CO.,**

NEWBURYPORT, MASS.

CHICAGO.

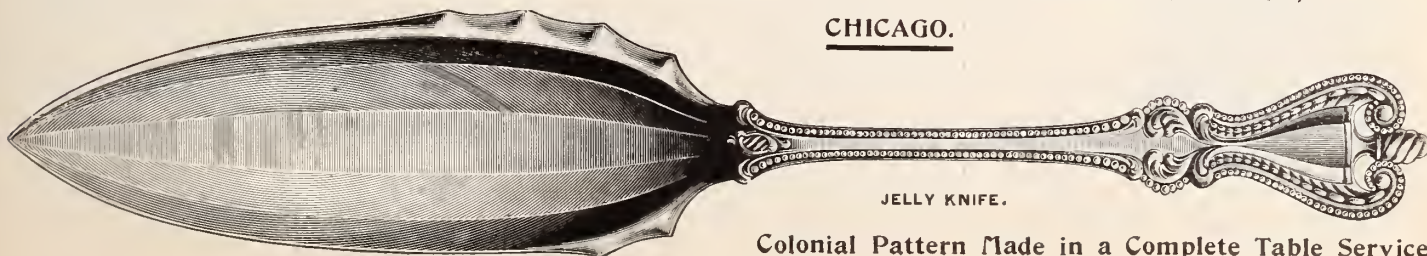

JELLY KNIFE.

Colonial Pattern Made in a Complete Table Service

### Cincinnati.

Wm. Oskamp, of Oskamp, Nolting & Co., has gone to Kansas City with his family to attend the silver wedding of his sister.

The Cincinnati Wholesale Jewelers' Association postponed their meeting for the discussion of the credit system until their next regular meeting.

C. J. Bene, of Bene, Lindenberg & Co., leaves for the east this week. S. Lindenberg and family will spend the hot months at their usual resort in the mountains.

Owing to there being another manufacturer who has adopted the name, "Royal," for cases, the Bell Watch Case Co. will drop the name this year and call the "Royal" case the "Bell Extra."

A. A. Greene, of the A. A. Greene Co., Providence, R. I., is on his way home from a trip through the west. He says he has sold more goods than he anticipated when he started out.

H. Von Reith, who recently came over from Europe and was associated with the Coetermans-Henrichs-Keck Diamond Cutting Co., Cincinnati, sails for Europe on the *Friesland* with four of the men he brought over.

The Homan Silver Plate Co. are putting in new cases for the display of their new goods for the Fall trade. Their sample room will be one of the handsome t in the city, and the visiting trade will find it the most attractive.

Bloom & Phillips were closed Saturday out of respect for John Hoare, the founder of the J. Hoare & Co. cut glass works at Corning, N. Y., whose death notice they had just received. This firm are the sole agents in this city for J. Hoare & Co.

The Ohio Retail Jewelers' Association who held their meeting at Piqua, O., last week decided that hereafter the State meetings and monthly meetings will be held in Cincinnati. The delegates to the National meeting will be appointed at the regular meeting this week. The election of officers of the State Association resulted as follows: President, A. Thoma, Piqua; vice-president, H. Rohs, Cincinnati; secretary, E. G. Lohmeyer, Newport, Ky.;

NEVER BLOTS. ADJUSTABLE ALWAYS READY.



**The Whitney Adjustable Fountain Pen.**

The only pen made using adjustable feed to regulate the flow of ink.

EVERY PEN GUARANTEED and money refunded if not satisfactory. Retailers from \$1.75 to \$5.00. Write for catalogue and discounts to dealers.

R. W. WHITNEY, 236 SUPERIOR ST., CLEVELAND, O.

EST. 1870. DR. PETER HENRY, SPECIALIST IN Watch Case Diseases

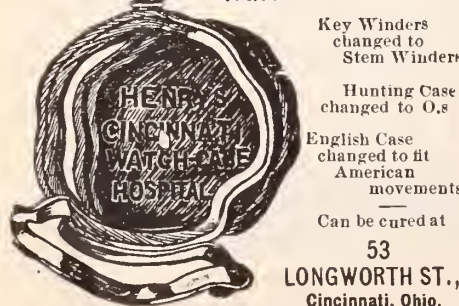

Key Winders changed to Stem Winders

Hunting Case changed to O.s

English Case changed to fit American movements

Can be cured at

53 LONGWORTH ST., Cincinnati, Ohio.

treasurer, Fred Pieper, Covington, Ky., board of directors, Louis Hummel, chairman, H. H. Mithoefer, Louis Honneck, Joseph Nurre, Cincinnati, and Fred Pieper, Covington.

The O. E. Bell Co. have secured the four story building at 412 Vine St., and will move their factory and stock there next week. The first floor will be the offices, the second the shipping department, the third the factory for the manufacture of leather novelties and the repair department, while the fourth will be devoted to the manufacture of the silver novelties which the company began last year with good success. The building has been renovated and equipped for their purposes and everything is in first class shape for the big industry in prospect. George Sheppardson, formerly with the Gorham Mfg. Co., has connected himself with the O. E. Bell Co. and will represent them on the road.

### St. Louis.

W. F. Kemper, president of the Missouri Retail Jewelers' Association, left for Louisville, Ky., on the 21st inst.

Pelton Bros. Silver Plate Co. resumed work on the 22nd inst. They have had an enforced shut-down since the cyclone, a portion of their building having been blown away.

The St. Louis Silver Co. are busily engaged on their new catalogue, which will be out in a month or six weeks. Tea sets tall, narrow urn shape are sold in large numbers by this concern.

Wild Bros. Jewelry Co., 104 N. 6th St., had a scare on the afternoon of the 19th inst. A small fire occurred next door and a dozen engines responded to the alarm. The blaze was extinguished promptly. In the meantime the large stock of watches, diamonds, etc. in the show windows had been stowed away in the safes of the concern.

### The Sapphire and Ruby Mines Of Southeastern Siam.

WHATEVER importance attaches to Chentabun as the second port of Siam is due to its position in relation to the gem-producing areas of southeastern Asia. Before the discovery of the sapphire and ruby mines, Chentabun was a poor fishing village. It is still a town of only 5,000 inhabitants, but it has secured a considerable measure of prosperity, and this prosperity dates from the time when the mines were first occupied by experienced gem-diggers from Burmah, British subjects who came over in increasing numbers and here founded Burmese mining communities, who have lived and been governed by themselves in all respects as if they were still in Burmah.

The mines are situated about midway between Chentabun and Battambang, to the east of a line joining the two points. There are two chief mining areas, separated by a wooded range of high hills, the Patat range, which runs northwest and southeast; on the northern slope of the hills is the sapphire district of Pailin, on the southern is the ruby district of Nawong. [The line of demarcation

is well defined, though a few inferior sapphires are found at Nawong and a few inferior rubies at Pailin. At present the Pailin mines are the more productive. They are on the main road, some 50 miles from Battambang. To reach them occupied me three days on pony back, and rarely have I passed through a more dull and uninteresting country than this vaunted province at Battambang. Along this road there is scarcely any cultivation and hardly any population. Long grass smothers the country for miles, the dust rises in clouds, the ground under foot is as hard as a metal road and as uneven as the bed of a mountain creek. There is an occasional village of half-a-dozen houses, and two other villages more important, with a combined population of 250. During the rains the country is almost impassable from the abundance of water; during the dry season the chief difficulty is the scarcity of water. Water can now only be obtained in muddy ponds churned and fouled by bullocks and buffaloes. The first night we reached the miserable village of Thangain. A wretched old hut, tumbling down and half open to the sky, was shown us as the *sala*, or resting-place for travelers. It was so bad that I refused to occupy it. "Send for the *kumnan* (the headman)," I said, "and I will occupy his house." "It is worse than this one," was the reply. The second night we camped out in the open.

The Pailin mines are spread over an area six miles by two, and consist of 13 mining villages, the chief of which are Baw Taka and Baw Dineo. These two are more than four miles apart, but they are joined by an excellent road cut through the forest and well drained. Sapphires are found all over this district; the whole country-side is riddled with holes sunk in the red soil down to the sapphire layer. Formerly the stones were found quite near the surface, but these places have long since been exhausted, although the Burmese still continue to turn over the old heaps in the firm conviction that precious stones grow. Now the stones are found at a depth of from 15 feet to 25 feet, in a reddish, gravelly layer of varying thickness up to eighteen inches. The pit sunk is usually some five feet in diameter, and either square or circular. Soil is raised in bamboo baskets attached to the end of a balance lever, and when the sapphire layer is reached the stratum is carried to the nearest water and washed carefully for stones. Not more than one shaft in three pays for its working expenses, but when the sapphire layer is struck the profits may be large indeed. It is all a question of luck. To dig and work out one shaft occupies two or three men one month. Two or three Burmese generally go into partnership and hire Laos miners to work for them and sink the shaft at the rate of two ticals (2s. 8d.) per eighteen inches. Occasionally sapphires of considerable value reward the miner, but the sapphires of Pailin are of more commercial value because of their quantity than because of their intrinsic excellence.—London Times.

DEPARTMENT OF  
ADVICE AND CRITICISM

ON  
RETAIL JEWELERS' ADVERTISING.

[This department is free to every retail jeweler and optician. Forward for criticism your newspaper ads., booklets, catalogues, novelties, circulars, etc. Ask advice and offer suggestions. Replies in these columns are unbiased. Make letters as full and particular as desirable. Every letter and ad. sent will receive full attention, though the publication of the matter may sometimes be delayed a week or two. Address all letters and other matters to The Jewelers' Circular Pub. Co., 189 Broadway, New York.]

PART XVIII.

of slang anywhere and in any manner; and an advertisement is meant to appeal to the whole



Expert Opticians.

You cannot be too careful about your eyes—especially should children's eyes be closely observed. Granulation, inflammation, drooping of the lids, squinting, pain in the eye-balls, a feeling as of sand in the eyes, are some of the indications of the need of glasses. We test astigmatic and all defective sight, guaranteeing the most perfect result possible. Why not save the oculist's exorbitant charges of from \$5 to \$50? We can give the best of references from those we have served and have given satisfaction to. Shall be pleased to have you consult with us at any time. J. F. JARVIS & SON, Expert Opticians 64 South Fourth avenue, Mt. Vernon, N. Y.

public. Mr. Fritz's five inches of space in the Oil City newspaper were well nigh wasted. The cut with an attractive, pleasing head-

TEST YOUR OWN EYES  
Try Each Eye Separately.

If the lines in this figure do not appear equally black at a distance of about three feet, it indicates defective sight, which should be at once corrected.  
Eyes Examined Free Correspondence Invited.  
MISS FRANCES WILZINSKI, Graduate Optician,  
871 First Ave., Lang's Drug Store, Seattle, Wash.

line, such as "As Beautiful as the Stars," together with specifications of appropriate gifts with low prices, would have made a much more effective ad., both as a money maker and as a builder of a desirable business reputation.

Recent Good Ads.

[Under this heading will be reproduced good ads. (introductory portions only) culled from various sources.]

LANCASTER, PA.

**THE HAMMOCK SEASON**

Is prolific with engagements. The engagement ring should come from my store, and later on the Wedding Presents.

Everything in Plain, Oval or Flat Band Rings. Of course you know I have a large assortment of DIAMOND RINGS, which are often preferred by the lady.

W. W. APPEL, 170 N. Queen Street,  
JEWELER AND OPTICIAN.

goods play little part, for the main object is to cause people to visit the optician's store to have their eyes examined.

The second class of pictorial advertising is that embodied in

This sort of advertising is not productive of immediate cash results, but it is a good policy of the jeweler to occasionally advertise in a manner that will tend to perpetuate the belief that the jeweler's wares are products of skill and art, and are not mere merchandise as the goods in the department stores are apt to be considered.

The third class of ad. illustrations are those seen in the ads. of J. Goodman & Son, Columbus, O., and Harvey Fritz, Oil City, Pa. They are pictorial representations of the catch lines of the ads. This method of advertising is widespread, especially in the smaller cities, towns and villages. The cuts in these cases are chic and pertinent, and thus fulfil their purpose, namely to attract the eye. But the remaining portions of the ads. are worthless. "Our prices are lower than the lowest" is a sentence which when first used may have produced large results; but it is trite and threadbare now, and has no effect. Everyone's prices are lower than the lowest. "Our stock is complete;" the same is to be said of this sentence.

THE use of chic, pretty or unique pictures in advertising is recognized as being advantageous. The average person likes to look at pictures, and in a page that contains both plain reading

**W. H. WILLIAMS & SON,**  
... Diamond Experts ...  
**CLEOPATRA'S JEWELS**

are a part of history. They have figured in poetry, painting, and song. And yet, the jewelers of Cleopatra's day really knew little about cutting and setting jewels. The modern lapidary and jewel setter is as far ahead of the ancients as the modern woman is ahead of Cleopatra. The world's best workers in gold, silver and precious stones have contributed to make our stock worthy of your attention. You are welcome to come and look when you like—buy when you are ready.

12 North Pearl St., Albany, N. Y . . . .

matter and pictorial ads. the latter will receive first attention from the reader. It must be constantly remembered that the two principal essentials in effective advertisement writing are that the ad. must be attractive by reason of its superficial individuality; and that the wording must be impressive. Pictures afford great opportunity for achieving the first result. A pointless and commonplace picture is worse than useless; and when it is remembered that the newspaper space occupied by the picture is usually large and expensive, it will be seen that considerable discrimination in the selection of illustrations is desirable. We present here five advertisements representing three classes of illustrations for retailers' newspaper advertising. First, there are the two optical ads.; the peculiar cuts attract by reason of their apparent meaninglessness. This will cause the reader to read the matter under the cut, and when this point is gained the object of the ad. is achieved. In such advertising, prices and descriptions of

the ad. of W. H. Williams & Son' Albany, N. Y. The evident purpose of the ad. is to impress upon the mind of the public the high character of the jewelry handled

**THESE ARE FOR YOU.**

Hadn't you better take them while you have the chance?  
Our prices are lower than the lowest.  
Our stock of DIAMONDS, in Ear Drops, Rings, etc., is complete.

**J. GOODMAN & SON,**  
Watches and Diamonds,  
9 East Town St., Columbus, O.

by the firm. The figure of Cleopatra is appropriate and lends artistic effect to the ensemble.

**OUT OF SIGHT**

Is the line of Sterling Goods, Cloeks, Cut Glass, Bric-a-Brac and Carvers in my stock, suitable for wedding presents.

**HARVEY FRITZ,**  
Jeweler and Optician,  
32 Seneca Street. Oil City

Messrs. Goodman & Son should have specified some goods with attractive prices. We doubt the propriety of using slang in advertising; some people detest the use

**Canada and the Provinces.**

W. A. Fenwick, Guelph, Ont., has given up business there and gone to Shelburne, Ont.

Hattie A. Fox, wife of Alex B. Odell, Sherbrooke, Que., is registered proprietress of the jewelry establishment of A. B. Odell & Co., of the same city.

Among recent visitors to Toronto were: L. Atkinson, New Market, Ont.; John England, Niagara Falls, south; T. F. Ferguson, Niagara, Ont., and Thomas Fitton, Exeter, Ont. The last has opened a branch store in Dashwood.

E. C. Fitch, president of the American Watch Co., passed through Montreal recently, on his way to his fishing and hunting preserve on the Romaine River, Labrador. He was accompanied by his son Charles, A. K. Sloan, of Sloan & Co., New York, and Dr. Brown, New York.

P. W. Ellis, jewelry manufacturer and wholesale dealer of Toronto, is taking a very active part in the political campaign. He is an effective speaker and has taken the Conservative platform at several meetings in favor of the maintenance of the present protective tariff, his addresses showing a great command of facts and statistics relative to trade conditions.

John Wanless & Co., Toronto, display in their window a fine trophy presented to the 48th Highlanders of this city, by John Wanless, Sr., as a prize for a shooting competition among members of the regiment. It consists of a handsome dirk and sheath, the latter being of solid ebony, mounted with silver and set with white cairngorms. It is of the firm's own manufacture and a very handsome piece of work.

Letters patent have been issued incorporating James Lewis Patterson, bookbinder; James Knowles, manager; Robert Alfred Eaton, commercial traveler; John Duthie, bookbinder, and William James Palmer, manufacturer, all of Montreal, by the name of "The Canadian Watch Case Company," with a capital stock of \$10,000, divided into 200 shares of \$50 each. The offices and factory of the company are situated on Craig St., Montreal.

Ambrose Kent & Sons, Toronto, are very busy this season on medals for provincial and other educational institutions. Some very elaborate and tasteful designs are being produced. Instead of the usual style, some medals are being made as pendants, with catches, etc., to allow of their being used as brooches. In some cases they are set with pearls and turquoises and display enameled crests.

Cyrille Duquet, Quebec, has suspended payment. It is understood that he will attempt to get an extension of time. The building of his new store is given as the principal cause of his difficulty, it having cost more than he contemplated. The liabilities are about \$18,000. It is claimed that he has a surplus of \$15,000 in stock, etc., besides a fair margin in his real estate. He has had some heavy losses in the past, but the impression is that he will be able to arrange satisfactorily, and continue business as usual.

**The Latest Patents.**

ISSUE OF JUNE 16, 1896.

**561,985. TIME-RECORDER.** EGBERT S. GAINES, Chicago, Ill.—Filed Mar. 25, 1895. Serial No. 543,078. (No model.)

**562,032. POCKET-BOOK.** JOSEPH ROSS, New

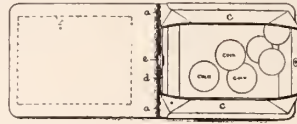

York, N. Y.—Filed Sept. 14, 1895. Serial No. 562,505. (No model.)

**562,060. COLLAR, CUFF AND STUBBUTTON.** ORESTA W. YOUNG, Chicago, Ill.—Filed Mar. 28, 1895. Serial No. 543,605. (No model.)

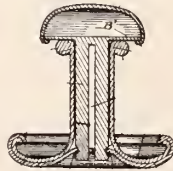

A cuff, collar and stud button consisting of a shank having a longitudinal slot therein with a groove near one end thereof and a circular disk at the other end, a crown attached to the circular disk by being turned over the peripheral edge thereof, an outer and hollow shank such hollow shank having a circular base, and a shoe having an aperture therein corresponding in diameter with the smallest diameter of the first-named and slotted shank, and such shoe attached to the circular base of the hollow shank by being turned over the peripheral edge of such circular base.

**DESIGN 25,632. BROOCH OR PIN.** SAUL PRAGER, New York, N. Y.—Filed Feb. 8, 1896. Serial No.

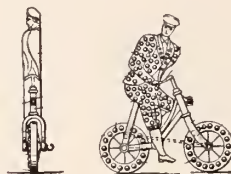

578,612. Term of patent 3½ years.

**DESIGN 25,633. SPOON.** PIERRE B. NOYES, Niagara Falls, N. Y., assignor to the Oncida Com-



munity, Limited, Kenwood, N. Y.—Filed May 4, 1896. Serial No. 590,232. Term of patent 3½ years.

**DESIGN 25,634. SPOON, &C.** ERNEST W. CAMPBELL, Providence, R. I., assignor to the Holmes



& Edwards Silver Company, Bridgeport, Conn.—Filed May 4, 1896. Serial No. 590,230. Term of patent 7 years.

**DESIGN 25,635. SPOONS, &C.** AUSTIN F. JACKSON, Taunton, Mass.—Filed April 21, 1896. Serial No.



588,523. Term of patent 14 years.

**DESIGN 25,636. HANDLE FOR KNIVES, &C.** PHILEMON O. DICKINSON, Newark, N. J.—Filed



Jan. 29, 1896. Serial No. 577,318. Term of patent 3½ years.

**DESIGN 25,637. NAPKIN-RING.** JOHN HASSELBRING, Brooklyn, N. Y.—Filed May 9, 1896. Serial

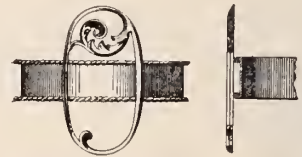

No. 590,949. Term of patent 3½ years.

**DESIGN 25,638. EYEGLASS OR SPECTACLE CASE.** JOHN CASEY and MURRAY S. CHISM, Phil-



adelphia, Pa.—Filed Apr. 16, 1896. Serial No. 587,867. Term of patent 7 years.

**TRADEMARK 28,383. NOTE, WRITING AND OTHER PAPERS.** WHITING PAPER COMPANY, Holyoke, Mass., and New York, N. Y.—Filed Apr. 18, 1896.

**ARGYLE LINEN**

Essential feature.—The words "ARGYLE LINEN." Used since 1880.

**TRADEMARK 28,401. THERMOMETERS.** THE



R. HOEHN Co., New York, N. Y.—Filed Apr. 6 1896.

Essential feature.—A figure of a red cross. Used since Feb. 1, 1896.

The Waterbury, Conn., National Bank directors have passed resolutions in honor of the memory of the late Augustus S. Chase, in the course of which they say: "In making this announcement the board of directors desires to give expression to a keen feeling of personal bereavement, as well as to a profound sense of the loss this institution sustains in the death of one, who for nearly 32 years, acceptably to the stockholders and the public, filled the office of its president."

## Workshop Notes.

**Waterproof Glue.**—In a cool place soak eight ounces of glue in a quart of good milk over night, and boil it next day; it will resist moisture much better than glue dissolved in water.

**Steady-pins.**—Two steady pins, well adjusted, are quite sufficient, and much better than pins made in the common, careless way, with which the bridge often goes on rather hard at the beginning, and allows some shake when close to the plate. The steady-pins should not be too long, for if they are they bend too easily. The length must not exceed double their thickness, and the pin wire must be drawn as hard as possible. To be effective, they must stand as far apart as the foot of the bridge will allow.

**Diamantine.**—The use of diamantine for polishing surfaces that perform a rubbing motion, such as the lifting of the teeth of cylinders and the largest pivots in watches, should be discountenanced. It is true diamantine makes a very handsome black polish, but no confidence can be placed in this polishing agent; on account of its great hardness particles will enter into the steel and be retained in it, and when the watch commences to go, it may be expected that the surface charged with the diamantine will quickly wear out the jewel hole or metal in which it works.

**Precipitating Gold in Gold Baths.**—The baths, when no longer fit for use, are filtered into a white glass flask, rendered alkaline with a little bicarbonate of soda, and a concentrated alcoholic solution of magenta is added. drop by drop, until the liquid has assumed the deep red hue of raspberry syrup. The flask is then exposed for six or eight hours to the light of a bright window. At the end of this time the gold is found to be deposited as a violet powder, whilst the supernatant liquor has become colorless. It is carefully decanted, so as to preserve merely the sediment. When a sufficient quantity of protoxide of gold has been thus collected, it is carefully washed upon a filter, dried, and the filter is burnt. The dry residue and the ash of the filter are then dissolved in *aqua regia*, and the solution, diluted with distilled water, is separated by filtration from the insoluble part.

**Oilstones.**—To keep a graver in good condition, the oilstone must always be fit for use. Constant use will soon cause its surface to lose its flatness, and bad hollows will soon appear upon it. When in that condition, it need not be thrown away and replaced by a new. It will pay to expend a little time and some hard and uninteresting labor upon it in facing it down. This can be done by rubbing the stone upon the coarsest piece of emery cloth that can be obtained. In doing this, see that the bench or piece of wood upon which the cloth is placed does not round upward, as in that case the surface of the stone would become concave in form, the very worst shape it possibly can have. A stone is in the best condition to sharpen gravers upon when

its surface is smooth, free from hollows, and in form slightly convex. The Arkansas oilstone only needs a finer finish than the coarsest cloth will give.

**Watch in beat.**—If you look on the bottom plate, by the rim of the balance, you will find three small dots or holes, likewise one on the balance rim. This is your guide for putting the watch in beat. If the watch is in beat at the one hole on the balance when turned around until it escapes will be exactly over one of the end holes of the three on the bottom plate. If not in beat by this method, you should make it so by loosening or unsevering the section of the bottom plate on which the balance bridge is screwed, and moving backward or forward just as it is until in beat, being careful not to bend anything. By this method you will find it easy and accurate. If the dot on the balance is not over the center dot on the lower plate, the cylinder has not been riveted correctly on the balance. This can be remedied by putting the dot on the balance rim perfectly over the center dot on the bottom plate after getting in beat.

**Caution About Breguet Spring.**—A Breguet spring should never be applied to a watch with an index. It is, perhaps, the best form of spring for a pocket watch, having all the properties in action of the cylindrical spring, and the great advantage of flatness in form, but any attempt at producing a good time-keeper with this spring and curb-pins will end in failure. And any attempt at getting time in positions by pressing the outer coil of the flat spring against the outer or inner pin is mere botching, and, even if successful, would require to be repeated every time the balance had to be taken out. For flat springs, with regulators, it would be highly advisable to pin a spring into the collet, in order to get the stud-hole and curb-pins to correspond. The end of the overcoil of a Breguet spring should run into the hole in the stud before being pinned in, and if the stud is screwed into the cock without the balance it will easily be seen whether the jewel-hole is in the center of the hole in the spring collet, as it should be.

## Watch and Lubricating Oils.

“THE principal demands,” says *Neue Erfindungen und Erfahrungen*, “generally made of a lubricating oil, are uniformity, and non-alteration—that is, the oil or the composition must always, and as often as it is composed, have the same qualities, and must change either not at all or at most very little after a prolonged storage; in this is embraced the thickening and gumming, whereby the resistance is increased. Another demand is that its indifference towards the parts of the mechanism be very large—that is, that its chemical properties shall keep the metallic parts with which it comes into contact as much as possible from destruction, and finally that it remain of a uniform consistence in varying temperatures.

“As regards watch oil, the latter condition is the principal, that therefore the oil remain

uniformly fluid, so that by thickening and gumming it suffer no change, and that it does not corrode the fine parts of the mechanism.”

So far so good. But the writer, Mr. Brunner, then betrays his woeful ignorance by saying that the “best lubricant for watches is either fine olive oil or freshly pressed sweet almond oil, either alone or mixed in equal portions.” As regards olive oil, it becomes viscid already at 38° F., and at 25° F. it congeals into a buttery mass. Nor does it keep; it becomes rancid very easily and proves to be a bad lubricant in all respects. The oil may, of course, be refined and the last traces of inherent acidity removed by diligent shaking with a certain quantity of caustic-soda lye. The color of the oil is removed by treating with alcohol. It is possible to obtain in this way pale oil entirely free from acid, but the thickening and becoming rancid cannot be counteracted by any known remedy, and for this reason it is useless as watch oil.

The oil of sweet almonds is better in certain respects, but equally possesses inherent defects that make it unfit as watch oil. If a watchmaker, reader of *THE CIRCULAR*, lives in a country or district where he cannot readily procure the really excellent American watch oil, and is compelled to prepare an oil himself, *THE CIRCULAR* would say that perhaps bone oil—neat’s foot oil—is best adapted. Of high merit is its quality of remaining fluid even at a low temperature; nor does it become rancid if thoroughly refined. Bone oil may be prepared specially for the purpose by exposing it to a very low temperature and then skimming off the congealed portion. It is still better to dissolve the oil in benzine and to submit the solution to cold, whereby the solid fats separate still more easily. The benzine is to be evaporated or distilled off after the separation, and the watchmaker will find that among the several makeshifts an oil prepared in this manner will suit him best.

Of late the employment of mineral oil is becoming prominent. It is to be refined as follows: The raw mineral oil is first shaken diligently with a saturated solution of hypochlorate of soda, and then placed aside to clarify; the clear decanted oil is next repeatedly shaken with milk of lime and again left to clarify. The separated oil is then shaken with one-third its volume of concentrated soda lye, and rectified by distillation. Brunner recommends the following method: 75 parts heavy coal tar oil are mixed with 1½ parts chloride of lime. To this are then added 2 parts crude hydro-chloric acid. The mixture must be strongly stirred after the addition of the acid, and then left to stand for six hours. After this time the oil is decanted from the watery fluid and repeatedly shaken with each 4 parts soda lye, and then filtered through blotting paper.

Since the refining of the mineral oil is fairly tedious, while the bone oil can be purified in such a manner that it offers a safe guarantee, it is to be preferred to the former, except in cases where a chronometer or watch is to be taken to a highly northern latitude. Mineral oil never congeals from cold.

# The "Safety Case" FOR Riding Specs.

SOMETHING NEW . . . .

THIS INGENUOUSLY MADE CASE FILLS A LONG FELT WANT. IT IS STRONG, COMPACT, DURABLE AND CONVENIENT.

Ask Your Jobber for Them.

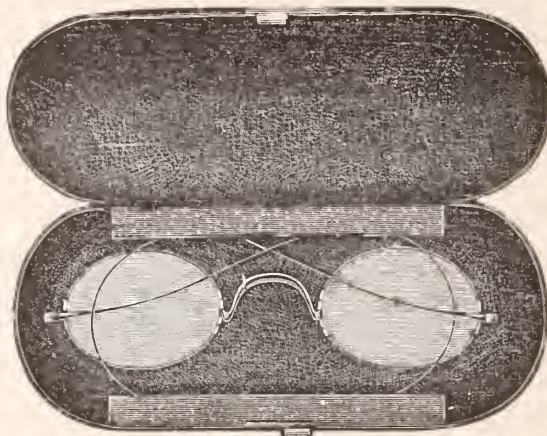

(PATENT APPLIED FOR.)

OUR REGULAR "SAFETY CASE," OF SIMILAR PATTERN, BUT SMALLER, IS THE BEST CASE EVER MADE FOR FRAMELESS, OFFSET EYEGLASSES.

For Sale by all Jobbers

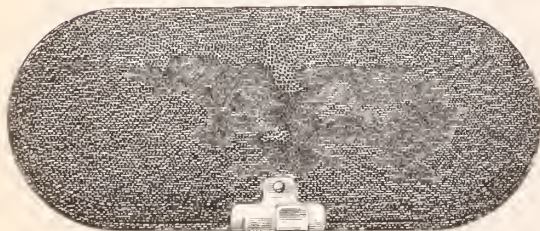

**SUSSFELD, LORSCH & CO.,**  
37 and 39 Maiden Lane, N. Y.

**THE SPENCER OPTICAL INSTITUTE**  
THE RECOGNIZED OPTICAL SCHOOL FOR BUSINESS MEN

OUR COURSE PRACTICAL COMPREHENSIVE NONCLASSICAL IN THEORETICAL AND APPLIED OPTICS

OUR STUDENTS ARE THE SUCCESSFUL OPTICANS

SEND FOR APPLICATION BLANK & PROSPECTUS. CLASSES CONVENE 1ST TUES. EACH MONTH  
SPENCER OPTICAL MANUFACTURING CO. 15 MAIDEN LANE. N. Y.

**WM. SMITH & CO.,** 5 and 7 MAIDEN LANE, NEW YORK.  
61 PECK ST., PROVIDENCE, R. I.

ESTABLISHED 1854.



MANUFACTURERS OF

**Gold, Silver and Rolled Plate Chains and Jewelry.**

Novelties in Gold and Silver Bead Necklaces and Bracelets. Also a large line of Chain Trimmings and Silver Rings.



**V**

Means everything that is first quality in Watch Glasses.

**T**

They are used by more Watch and case makers than all others.

**F**

Their success has induced others to copy the label but not the quality.

**Fox & Stendicke,**

Manufacturing Opticians,

61 Fulton St., New York.

Javal, Schiötz Ophthalmometers, Phorometers, Skiascopic Apparatus, etc., etc.

Send for Price List.

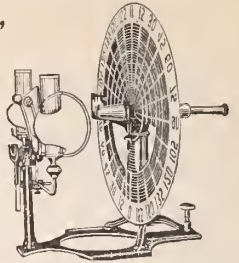

FOR RELIABLE OPTICAL WORK

SEND TO

JOS. FRIEDLANDER & BRO.,

OPTICAL LENS GRINDERS,

9 MAIDEN LANE, - - NEW YORK.

SEND FOR DESCRIPTIVE CIRCULAR OF OUR FRAME AND LENS CABINET.

## Optical Books.

Any book pertaining to the subject of ophthalmology can be obtained through the Jewelers' Circular Publishing Company. Send for new catalogue just issued. It is free.

## DR. KNOWLES' PRIVATE COURSE IN OPTICS.

Lectures with Diploma \$25.00

Those who desire to study with the Doctor will send in their application.

Students received at any time.

CORRESPONDENCE COURSE PERFECTED.

*The Key to the Study of Refraction.*

50c. per copy,

For Sale by

R. H. KNOWLES, M. D.,  
189 Broadway, NEW YORK.  
Care of JEWELERS' CIRCULAR.

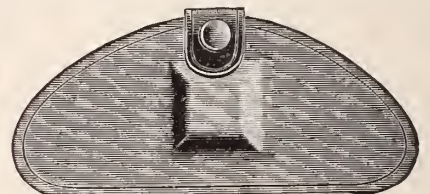

EXTRA THIN.



IN TWO SIZES.

**KOENEN'S NEW SHELL CASE**

FOR OFFSET EYEGLASSES.

THE LATEST AND BEST. THIN AND STRONG.

Manufactured and Patented by

**A. KOENEN & BRO.,** 81 Nassau St., N. Y.

SOLD BY JOBBING TRADE.

# OPTICAL DEPARTMENT.

## Ocular Refraction.

AS RELATES TO THE CORRECTION OF VISUAL DEFECTS\*

BY R. H. KNOWLES, M. D.

**NOTE.**—The purpose of this series of articles is to give to the student without his having had any previous technical education, a clear and practical course of instruction in optics with its application to the fitting of glasses. The Correspondence Column is open to all readers of THE JEWELERS' CIRCULAR. All questions asked will be fully answered.

XXXV.

(Commenced Feb. 27, 1895.)

### CHAPTER VIII.

**D**R. R. H. KNOWLES prepared an address on "Asthenopia and its Relation to the Errors of Ocular Refraction," for the recent meeting of the Optical Society of the State of New York, which, on account of his enforced absence, was not read. It was essentially as follows:

That prisms and decentered lenses play an important part in the prescriptions of the refractionist goes without saying, but that prisms are prescribed and lenses are decentered, in many instances when they should not be, is the writer's reason for presenting an article in behalf of suffering humanity who have enough with which to contend without additional burdens placed upon them, and that, in many instances, the lenses are prescribed by refractionists who have a little knowledge of the subject and who do know how to make tests for muscular insufficiencies, makes it imperative to make the subject an exhaustive one, and in many instances when they are in doubt about the muscular strain and the consequent nervous phenomena, in which cases prisms and decentered lenses do nothing but result in permanent injury.

Asthenopia, or weak sight, as the term implies, refers to a strain placed upon the muscles controlling the movements of the eyes in which we have, as a result, pain and blurring, especially while reading, and in consequence of which there is a headache which locates itself in the temporal region and at the base of the brain.

The pain to which allusion is made is due to the strain placed upon the weakened muscle in its effort to maintain equilibrium, and the failure to do this allows the eyeball to rotate upon its axis and the blurring of the image results.

The nice adjustment of the muscles controlling the movements of the eye, other things being equal, depends upon the vision. If the eyes are in Emmetropia they will also be in Orthophoria, exceptional instances are found in the reflex variety alone, and this one exception proves the rule.

Again, it will be found that Asthenopia is the forerunner of a more pronounced state and that if the error is allowed to go uncorrected, vision in one of the eyes, from want of use, will become more or less Amblyopic so that

Asthenopia should be considered as the primary or initial stage of squint and strabismus the more advanced stage.

For our convenience in the study of Asthenopia, we subdivide the subject under three headings.

Asthenopia { Accommodative,  
Muscular,  
Reflex.

Accommodative Asthenopia suggests to the mind that hypermetropia is the cause of the Asthenopic symptoms, that in Axial Hyperopia the strain is placed upon the external rectus caused by over-stimulation of the sphincter iris in the act of Accommodation together with excess of convergence from extra activity of the internal rectus acted upon through the third pair of nerves, the motor-oculi, the result will be that in hypermetropia there will be a proportional amount of esophoria. In simple hyperopic astigmatism the tending of one eye to turn downward while its mate will tend to turn upward in a direction toward one another, the obliques being involved and in consequence of which we have right and left cyclophoria. In compound hyperopic astigmatism, the external rectus together with the obliques, there will be a proportionate hyperesophoria. If the hyperopia exceeds the hyperopic astigmatism the tendency will be more in esophoria than hyperphoria and vice versa if the hyperopic astigmatism is in excess. In hypero-myopic astigmatism the external rectus together with the superior and inferior recti are relaxed.

Muscular asthenopia is due to some form of myopia. In axial myopia the internal rectus is not sufficient to maintain equilibrium because the third pair of nerves are not stimulated as the dilator iris through the influence of the sympathetic nerves renders the crystalline lens as flat as possible, and thus the tendency is outward with a resultant insufficiency of the internal rectus, and consequent exophoria.

In simple myopic astigmatism there is an insufficiency of the superior and inferior recti, right and left hyperphoria. In compound myopic astigmatism the internal, the superior and inferior recti are relaxed in hyperexophoria. In myo-hyperopic astigmatism the internal rectus and the obliques are not sufficient to maintain equilibrium.

Reflex asthenopia depends upon the nervous system for a cause as the weakness placed upon the muscles controlling the movements of the eye is secondary and symptomatic of some disease outside of the eye. Dyspepsia, diseases of the genito-urinary tract, are all causes bringing about asthenopic symptoms, and in no instance, pure and simple, can an error of refraction be found in this variety, although in the other varieties the reflexes may also be associated with them.

From the foregoing remarks it will be seen that errors of refraction play a large factor in bringing about asthenopia, and even the more

advanced type, strabismus. That if a solution of atropine will straighten the eye, the correction alone is all that should be prescribed for, if after the correction is given and prisms are conjoined with the correction, the question naturally arises what is being done for the permanent restoration of the weakened muscles if it is allowed to remain relaxed, and even forced to remain in that state? It seems that a permanent injury will result rather than a restoration, and we defeat the very purpose we should strive to gain.

Orthoptic exercises should be exercised in order to produce a tonic effect of the weakened muscles, and as the normal tendency, like diseases, is toward recovery, the additional gymnastic exercises facilitate this recovery, whereas prisms or decentration of lenses will retard.

In summarizing, first correct the existing error of ocular refraction; second, experiment with prisms, and finally, if the pain, blurring and headache continues and there still remains any heterophoria, or if the advanced stage is pronounced, and there is some form of heterotropia, an operation of tenotomy is in order, with a view of not only acquiring a cosmetic benefit but that the eyes themselves shall be restored to equilibrium.

### The Bailey Patent Rubber Guard.

**T**HE American Optical Co., Southbridge, Mass., have obtained the exclusive right in the United States, Canada and Mexico to make the Bailey patent rubber nose guard, and are prepared to furnish them mounted on eyeglasses of all styles, or as guards only. The company can also furnish the rubber



facing in strips or sheets. This guard accomplishes what has never yet been obtained by any other covering for eyeglass guards; it holds the glasses securely in position and is not affected by perspiration or different positions of the head; made cup-shape it holds like a fly's foot, and being soft and flexible at the top the pressure is very light and comfortable, if the spring is properly adjusted, and owing to the construction of the guard the spring does not need to be as strong as an ordinary guard eyeglass; the distance between the cups allows ventilation and does not retard the circulation; the impression caused by wearing this guard is very light and soon passes away when the glasses are removed. This guard can be furnished by any jobber.

Jeweler Frank Kline, Royersford, Pa., will present a gold and silver medal to the two scholars in the highest grades who make the best average in their studies. The medals have been on exhibition and will be presented on the night of the commencement.

## A reputation the world over

THE "ROGERS"  
ANCHOR BRAND OF  
SILVER PLATED WARE  
HAS MET ALL COMERS  
FOR THE PAST FIFTY  
YEARS.

IT HAS BEEN PERFECTED WHEREVER THERE HAS BEEN A CHANCE TO BRING IT NEARER TO PERFECTION. ITS BEAUTIFUL DESIGNS AND ITS THROUGH AND THROUGH QUALITIES HAVE WON FOR IT A GOOD REPUTATION THE WORLD OVER.



"ANCHOR" BRAND

FACTORIES:

Hartford, Conn.    Norwich, Conn.  
Wallingford, Conn.    Taunton, Mass.

WM. ROGERS  
MAN'F'G CO.,

Office and Salesrooms:  
Hartford, Conn.



A DULL TIME like the present, sets us all at work to improve our goods.

WE have made a special study of One Piece Pin Stems, Joints, Catches, etc., and are furnishing these findings to manufacturers in gold, sterling silver, and other metals.

These are acknowledged to be the best made. This sounds big. It is. Will you allow us to demonstrate it to you?

B. A. BALLOU & CO.,  
61 Peck Street,  
Providence, R. I.

**W. H. SCHWARTZ & CO.**  
MANUFACTURERS OF FINE  
**JEWELRY**  
AND  
NOVELTIES  
IN GOLD AND SILVER.  
355 Mulberry Street.  
Newark, N. J.

ESTABLISHED HALF A CENTURY.

**MARVIN'S**  
FIRE & BURGLAR  
**SAFES**

HAVE MANY PATENTED IMPROVEMENTS  
NOT FOUND IN OTHER MAKES  
THAT WILL WELL REPAY AN  
**INVESTIGATION**  
BY THOSE WHO DESIRE TO SECURE  
**THE BEST SAFE**  
MARVIN SAFE CO.

12 PARK PLACE, NEW YORK.

## THE SWAN FOUNTAIN PEN

Reputation World Wide.  
Made upon Distinct Principles.  
Is a Compressed Air Pump.  
Simply Wet the Insides to Provoke  
an Energy.

W. W. Stewart, Inventor and Patentee.

A variety of Styles and Prices

- 3 Sizes Safety Swans.
- 3 Sizes Self-filling Swans.
- 3 Sizes Adjustable Feed Swans.

**MABIE, TODD & BARD,**

NEW YORK AND LONDON.

**O. NEWMAN,**  
Gold and Silver Electro-Plater,  
Etruscan Coloring a Speciality.  
WATCH CASE POLISHING.

75 Nassau St., Room 8 Rear Building, New York.

**H. M. RICH & CO.,**  
Jewelry - Auctioneers,  
21 School Street,  
BOSTON, MASS.

**FERD. FUCHS & BROS.**  
**SILVERSMITHS.**  
MAKERS OF STERLING SILVERWARE,  
808-810 Greenwich St., - New York





## The Rambler's Notes.

WHAT THE RAMBLER SAW AND HEARD AMONG THE DEALERS IN ART POTTERY, CUT GLASS BRONZES ETC

NEW B & H. BANQUET LAMPS

THE banquet lamps for this season shown by the Bradley & Hubbard Mfg. Co., at their salesrooms, 26 & 28 Park Place, New York, are slightly shorter than those of last year, but have founts of the same size as formerly. Over 100 different new varieties are shown in many pleasing patterns and finishes. Two very graceful styles of lamps are in height midway between the banquet and table sizes.

THE POPULAR FERN POT.

ONE of the many articles in French china whose combined utility and beauty have given it a place among the leading china novelties, is the fern pot, which this year is shown in large varieties. In one make alone, the A. K. Limoges china, the assortment this season has been increased manifold over that of last year, and show decorations of an almost infinite variety. Among the most popular ferneries shown by C. L. Dwenger, 35 Park Place, New York, who controls this ware, are the footed varieties in the small oval and large round shapes.

NEW WEDGWOOD GOODS.

AT the salesrooms of Hinrichs & Co., 29-31 Park Place, New York, a new line of the standard pieces in Wedgwood Jasper ware have just been opened and are now on display. Vases, jugs, Etruscan vases, ewers, jars, teapots, sugars, creams, urns, caddies and cracker jars are shown in but one color, the dark blue, but are obtainable in several sizes. Four sizes of the celebrated Portland vase are shown in this color.

THE RAMBLER.

## Modern Japanese Porcelains.

A WRITER in the *Japan Mail*, of Yokohama, discussing the aims of the modern Japanese ceramist and the principles which now guide him, says the porcelains of Hozen and the faiences of Satsuma and Kioto, to

which the ceramic art of Japan owed its distinction before the present reign, never could compare with the productions of the Chinese kilns. Chinese potters, from the early years of the Ming dynasty to the end of the 18th century, were unrivaled as makers of porcelain, and the representative specimens of their work remained, until lately, far beyond the imitative capacity of European or Asiatic experts. Faience and pottery in all forms the Chinese despised, with the exception of the kind known in the west as "baccaro," and even this was popular because of its special utility as the ware of the tea-drinker rather than for its decorative beauty.

The artistic productions of Chinese kilns in their palmiest days were porcelains, whether of soft or hard plate, while Japan owes all her ceramic distinction to her faience. In the wide field of monochromes and polychromes, striking every note of color, from the richest to the most delicate, the Chinese developed wonderful skill, whereas the Japanese can scarcely be said to have worked it at all. Here the Chinese used to stand alone and apparently inaccessible, while the Japanese devoted themselves to faience and produced their wonderful old Satsuma. In the early years of the new era in Japan there was a period of complete art prostitution, when attempts were made to satisfy what was thought to be foreign taste; but in course of time the Japanese potters began to find inspiration in the monochromes and polychromes of the Chinese kilns.

The extraordinary value attached by American connoisseurs to the red glazes of China, led the celebrated Miyagawa to attempt to imitate the rich and delicate "liquid dawn" monochrome, and his example was followed by many others, so that the Japanese began to renew their ceramic reputation by reverting to Chinese models. There are now seven kilns in various parts of Japan devoted to this work of renaissance. The writer describes the special characteristics of each of these. It seems that of the seven artists controlling these establishments six produce their chromatic effects by mixing the coloring matter with the glaze, while Seifu of Kioto paints the porcelain with a pigment over which runs a translucent, colorless glaze. On the whole, it appears that the Japanese ceramist, after many efforts to cater to the tastes of the West, concludes that his best

hope is to devote all his technical and artistic resources to reproducing the celebrated wares of China, and it is not a little remarkable that China, at the close of the 19th century, should be once again furnishing models for Japanese eclecticism. Yet it is doubtful whether in this respect the Japanese will ever attain the excellence of his Chinese masters.

## Limoges Centennial.

THE city of Limoges is preparing to celebrate the centenary anniversary of the introduction of the manufacture of hard porcelain into France. The origin of this grand industry dates back but a hundred years, and the forthcoming celebration will demonstrate the progress accomplished and the point of perfection attained to-day in that admirable product of French industrial art. The exhibition of the Limoges porcelain industry will be opened on July 1 in the great halls of the Limoges City Hall.

The exposition will show the entire history of the manufacture of porcelain from its inception down to our days, indicating the progress made in the choice of first material, in tools and machinery, in the firing of porcelain and in the form and decorating of the product. Besides hard porcelain, the exposition will be open to all ceramic productions of the district, comprising architectural decorative ware, terra-cottas, faiences and artistic earthenware. The great factories of Limoges will all be represented, and the exhibition promises to be very interesting.

## Souvenir Spoons as a Record of Race Winnings.

A CUSTOMER of Spott & Jefferson, jewelers, Little Rock, Ark., has a novel way of keeping a record of her horse's winnings. With the opening of the Spring meeting in Little Rock she made a contract with the jewelers to furnish her with a tablespoon of Gorham pattern for each stake race won, and to engrave in the bowl of the spoon the name of the horse, the name of the stake, the city where won, and the time.

So far, nine tablespoons have been engraved for her, and the end is not in sight, for she has a stable full of winners.

## Gold and Silver Dishes for the Czar.

AMONG the innumerable presents which the Russian imperial couple have received from their loyal subjects, gold and silver dishes play a prominent part, says the *London News*. It is an old Russian custom to offer salt and bread on such dishes, of which the imperial house now possesses several thousands. During the present festivities about 300 were presented to the imperial couple, most of them having been made by Moscow jewelers.

A correspondent of the *Lokalanzeiger*, who saw them there, writes: "There were great round dishes or trays weighing a hundred weight and a half, with exquisite work in relief. Such, for instance, was the much admired present of the nobility of Pensa. This dish seems to be made completely of gold and silver ears of corn, out of which peep the coats of arms of the chief towns. The salt cellar belonging to it is a sheaf of rye, and is so exquisitely worked that one almost doubts whether the ears are not real. Other dishes are small and elegant, as, for instance, the three-cornered one from the Orenburg Cossacks, representing an oak wreath with an enamel band intertwined in the national colors. Wreath and band encircle a relief representing Cossack attributes.

"Exquisite is a large dish completely covered with gayly colored enamel in pure Byzantine style. The costly present comes from Nishni-Novgorod, and cost, with the salt cellar, 2,000 rubles. The Bourse Committee of this town has given a still more valuable

present—a dish which is adorned with precious stones from Siberia. A wreath of dark violet amethysts winds around the edge, while the center is covered with garnets and white mountain crystals. Siberian amethysts are celebrated for their color, and are comparatively cheap.

"One of the Cossack hordes sends an original dish of oxidized silver. The edge forms a frame to a picture, which is also dark, and represents Bogdan Chmelnitzki signing the union treaty between the Ufraine and Moscovia. The salt cellar belonging to it is an exact copy of the monument raised at Kiev to this celebrated Attaman, whom Russophiles regard as a hero, but whom the Saporag Cossacks look upon as a traitor. About a dozen dishes have beautiful portraits of the imperial couple; one, from the merchants in Charkow, was executed from drawings by M. Wasanezoff, the most celebrated painter of ecclesiastical pictures in Russia.

"The dish of the St. Petersburg Bourse has the Czar's monogram in large diamonds and rubies. It is the most expensive of all the dishes I saw. The top of the salt cellar belonging to it consists of a ruby the size of a small hazelnut and of magnificent color and brilliance.

"Of pictures and images of saints, there are dozens. Some are of gold and silver, some are carved in wood by patient peasants, who cannot even count up to five, and yet produce regular works of art with a simple pocketknife. Every material which can be worked into anything has been used, even paper and linen. Pearls especially are much used. The garments of the saints are covered

with small pearls, and this has a charming effect. St. Nicholas, the worker of miracles, who is particularly revered in Russia, and the Czarina Saint Alexandra, the patron saint of the young Empress, are among those most represented. Most of these pictures and images of saints will later on be distributed among the numerous churches of the poor villages. The most valuable or artistically rare ones remain in the cathedrals of the two capitals."

The same correspondent tells a story which, if it is well founded, certainly shows M. Witte's financial talent. On his advice medals were struck to be bestowed upon all those who served under the late Czar, either in the military or in the civil service. Every man who receives such a medal would have to pay two rubles for it, while the cost to the State is 25 kopecks, or an eighth of a ruble. *Se non vero*.

### BREAKING SETS.

LADY CUSTOMER (in china shop)—Do you break these sets?

DEALER—No, madame; the purchasers' servants usually attend to that.—*Houston Post*.

### A COSTLY RING.

"Have you any idea of the price of the most costly ring ever made?" asked Mrs. Watts, looking up from her paper, from which she had been reading about jewels. "Dunno," answered Mr. Watts; "I know the one I put on your finger has been costing me from \$2,000 to \$2,200 a year ever since."—*Indianapolis Journal*.

## SLOAN & COMPANY,

SUCCEEDING

JOHN A. RILEY & SLOAN CO.,

MANUFACTURING JEWELERS,

23 MAIDEN LANE, N. Y.

HAYS BUILDING.

AUGUSTUS K. SLOAN, Pres.  
FRANK T. SLOAN, Vice-Pres.

BENNET OSBORN, JR., Treas.  
ALLAN A. McDONALD, Sec'y.

## MATHEY BROS., MATHEZ & CO.,

Brassus, Switzerland.

21 & 23 Maiden Lane, N. Y.

SOLE AGENTS:

## CHAS. MEYLAN WATCHES.

# SPLITS

A SPECIALTY.

**RAZZLE RINGS**  
**FOZZLE**

MADE BY HASKELL N.Y.

HENRY C. HASKELL,  
11 John St., New York.

Send  
For  
New  
Price  
List.

## WOOD & HUGHES, STERLING SILVERWARE MANUFACTURERS

New York Agents for the Derby Silver Co.,  
FINE QUADRUPLE PLATED WARE,  
No. 16 JOHN STREET, - - NEW YORK  
206 Kearney St., San Francisco, Cal.  
HASKELL & MUEGGE, Agents.

**SECURITY PIN GUARD**  
PAT'D DEC. 25, 1894  
MANFD BY SECURITY MFG CO. **25¢**  
7 ASTOR HOUSE (BROADWAY) N.Y.

85c. doz. Net Cash Discount to Jobbers

## JACOT & SON,

Importers and Manufacturers of

## Musical Boxes,

39 Union Square. New York.

SEND FOR CATALOGUE of books for the jewelry and kindred trades. Just issued. JEWELERS' CIRCULAR PUB. CO., 189 B'way, N. Y.

**Q**RE always of **Standard Quality, of Newest Styles and Best Finish.**

They will always sell when anything will, and cost no more than those of doubtful reputation.

Don't wait for our travelers, but send direct to

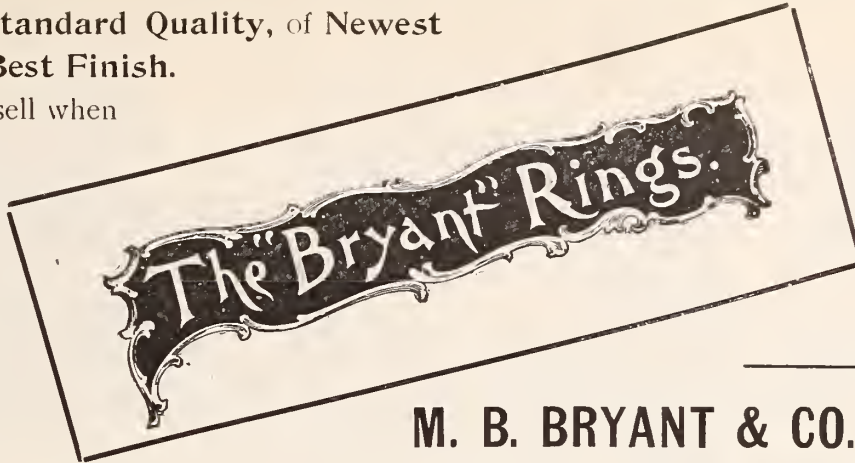

**Oldest Ring Makers in America.**

**M. B. BRYANT & CO.,** 10 Maiden Lane, N. Y.

**NYE'S SUPERFINE OILS.**

Special grades for



CHRONOMETERS, WATCHES, CLOCKS, JEWELERS' LATHES, ETC., ETC.

NYE'S OILS acknowledged SUPERIOR TO ALL OTHERS.

**WM. F. NYE,** Manufacturer, New Bedford, Mass.

We carry the largest, finest and most complete line of Mounted Diamond Jewelry of any house in America.



**KETCHAM & McDOUGALL,**

MANUFACTURERS OF

**GOLD AND SILVER THIMBLES**

ESTABLISHED 1832.



TRADE-MARK.

And the improved

**Automatic Eye-Glass Reel.**

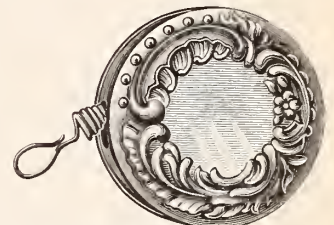

Pat'd Nov. 20, '94.

SEND FOR CATALOGUE C.

198 BROADWAY, NEW YORK.

**COMFORT AND SECURITY**  
ARE COMBINED IN MERRITT'S PATENT EYE GLASS HOLDERS.

Made by Merritt Gargill & Co. Springfield, Mass.

GOODS ON APPROVAL. CORRESPONDENCE SOLICITED.

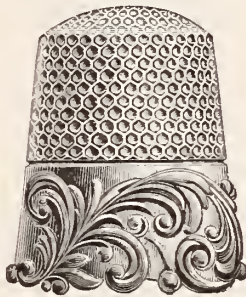

No. 149

**AIKIN, LAMBERT & CO.,**  
MANUFACTURERS OF  
**FINE GOLD PENS, HOLDERS, PENCILS, TOOTH PICKS, and NOVELTIES.**

PAUL E. WIRT FOUNTAIN PENS, at new and lower prices . . .  
MERCANTILE FOUNTAIN PENS, guaranteed to give satisfaction.

Catalogues with terms and discounts furnished to the trade.

BRANCH, 103 STATE STREET, - - - CHICAGO.

**AIKIN-LAMBERT JEWELRY CO.,**  
IMPORTERS OF  
**DIAMONDS.**

JOBBERS IN

**WATCHES, JEWELRY, CHAINS, NOVELTIES, ETC.**

LATEST DESIGNS.

LOWEST PRICES

**19 MAIDEN LANE, NEW YORK.**



**CYCLING PROGRESS  
EXEMPLIFIED.**

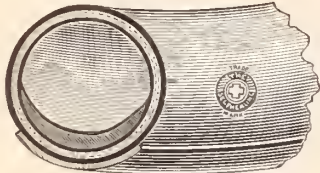

**THE WONDERFUL  
SELF-HEALING TIRES**

are single tube, finest rubber, finest wove Sea Island cotton fibre, re-enforced inside and outside on tread, and no better tire can possibly be made. They are fully guaranteed against all climatic changes, are the most resilient ever made, and when punctured instantly heal the wound of their own volition.

THEY WEIGH NO MORE THAN OTHERS,  
COST NO MORE,  
AND ARE WORTH TEN TIMES MORE.

— SEND FOR TIRE BOOKLET —

**Wm. H. CAHN, GENERAL MANAGER,**  
48 and 50 Maiden Lane, New York.

BY EVERY TEST THEY ARE THE BEST.  
THE UNIVERSAL FAVORITES.



SUPERB  
**Olympic**  
BICYCLES

For sale by more than 2,000  
Jewelers and constructed to meet  
the demand for finest quality.  
For Adults and Juveniles.

SEND FOR EXQUISITE  
CATALOGUE.

Top Grade "Olympics" have SELF-  
HEALING TIRES.

Olympic Cycle Mfg. Co.,  
N. Y. Office: 35 LIBERTY STREET

General Jobbing Ag'ts, S. F. MYERS & CO.,  
WHOLESALE JEWELERS, Myer's Building, New York.

**RECEIVER'S SALE!**

**TRADE OPPORTUNITY.**

Entire Stock of

**CHAS. JACQUES CLOCK CO.,**

22 Cortlandt St., New York,

**...Must Be Closed Out...**

Latest Paris Novelties,  
all New Importations  
of this Spring

Together with LARGE STOCK of

**ELLIOT CHIME CLOCKS,**

And a Fine Line of Other

**HALL CLOCKS.**

By order of

**ALBERT C. WALL, Esq.,**

Receiver.

No jeweler or watch repairer should  
be without a copy of "WORKSHOP  
NOTES," a new and very useful book  
for the workshop. Send for circular  
containing a complete index of the  
book, and judge of its merits for  
yourself.

**BAWO & DOTTER,**

26-32 BARCLAY ST.

NEW YORK.

P. O. Box 1872.

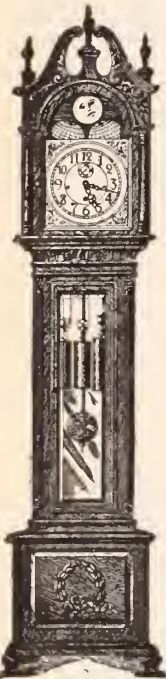

NO LARGER STOCK  
OF

**HALL  
CLOCKS**

IS SHOWN IN  
THIS CITY.

Large Stock  
OF  
MOVEMENTS.

NEW DESIGNS  
IN CASES.

CAMPBELL-METOALF SILVER CO.,  
SILVERSMITHS,



ALL GOODS 925/1000 FINE.  
Factory, Providence, R. I. Offices, New York and San Francisco.

**DUBOIS WATCH CASE CO.**



FINE HAND MADE  
**SOLID GOLD CASES.**

A PRIDE TO THE MAKER,  
DEALER & WEARER.

**L. LELONG & BRO.,**

GOLD AND SILVER

Refiners, Assayers and Sweep Smelters,

◁ SOUTHWEST CORNER HALSEY AND MARSHALL STREETS, ▷

**NEWARK, N. J.**

SWEEPINGS A SPECIALTY.

**STERLING**

SHEET AND WIRE SUPPLIED ALL SIZES.

**J. SCHAWEL & CO.,**

Gold, Silver and Platinum Refiners.

29 John Street, N. Y.



TRADE MARK REGISTERED

**SOLID GOLD CASES**

ARE ALL STAMPED WITH THIS  
TRADE MARK AND WARRANTED BY

**THE ROY WATCH CASE CO.**

ALBERT LORSCH.

ALFRED KROWER

**ALBERT LORSCH & Co.,**

LORSCH BUILDING

37 & 39 Maiden Lane,

NEW YORK.



167 Weybosset St.,

PROVIDENCE, R. I.

IMPORTERS OF **DIAMONDS, RUBIES, EMERALDS, ETC.,**  
AND IMITATION STONES THEREOF.

• • Fine Miniatures on Ivory and Enameled Paintings. • •

**DIAMONDS** Importers and Cutters. **L. & M. KAHN & CO.,** 172 Broadway, Cor. Maiden Lane, N. Y. **DIAMONDS**



# THE JEWELERS' CIRCULAR

## AND HOROLOGICAL REVIEW.

Copyright by THE JEWELERS' CIRCULAR PUB. CO.

189 Broadway, New York.

Entered at the Post Office in N. Y. as second-class matter

VOL. XXXII.

NEW YORK, WEDNESDAY, JULY 1, 1896.

No. 22.

### THE GENESIS AND ARTISTIC DEVELOPMENT OF THE LOVING CUP.

Copyright, 1896, by THE JEWELERS' CIRCULAR PUB. CO.

#### PART III.

THE cup from the tomb of Koul-Oba, of Scythia (fourth century, B. C.), in its larger details of design is seen in a modern

development in the Vigilant Cup, here shown, produced by the Gorham Mfg. Co., New York. The cup was a recognition by the New York Yacht Club of the disinterested patriotism of Geo. J. Gould, in his sending of *Vigilant*, the successful defender of the America's cup, of 1893, from European waters at a great expense, to test the racing qualities of *Defender*. The design of the cup is graceful, suggestive in every detail of the sea, with a freedom from conventionality especially manifest in the treatment of the handles, which have a clear, free, artistic sweep. The cup is in the form of a Greek kylix, with spreading handles. It stands on an ebony base in the form of a Roman altar, decorated with four applied silver figures of mermaids, draped with streaming festoons of seaweed. The top of the base is made to turn, showing the cup on all sides. Around the spreading neck

of the cup is a band of flowing water, out of which rises the head of a singing Circe, whose falling hair mingles with

on the back the seal of the club in relief. The base of the cup is beaded, nautilus shells, with seaweed being placed at the four corners. The inscription on the front of the cup, below the Circe is as follows: "The New York Yacht Club to George J. Gould, Esq., in recognition of his sportsmanlike conduct in placing the *Vigilant* at the disposal of the club in defence of America's cup during the season of 1895." The cup is 14 inches in height and the base 11 inches. The handles have a spread of 24 inches, and the whole cup weighs 150 ounces. It is in soft oxidized finish, and is an exceedingly handsome and creditable piece of work.

Regarding the drinking customs of the Romans, little can be written. The gallants had a habit of drinking as many glasses as there were letters in the names of their mistresses. Martial wrote: "Six cups to Naevia's health go quickly round, And be with seven the fair Justina's crown'd"

Regarding the drinking customs of the Romans, little can be written. The gallants had a habit of drinking as many glasses as there were letters in the names of their mistresses. Martial wrote:

"Six cups to Naevia's health go quickly round, And be with seven the fair Justina's crown'd"



THE VIGILANT CUP—FOUNDED ON THE GREEK KYLIX.

of the base is made to turn, showing the cup on all sides. Around the spreading neck

the waves. On the sides of the rock, opposite the handles, are two æolian harps, and

We find no specific mention of a custom resembling that embodied in the use of the lov-

# KENT & STANLEY CO., LTD.,

## JEWELERS AND SILVERSMITHS,

### SEAMLESS GOLD FILLED CHAINS, JEWELRY, SILVER NOVELTIES.

NEW YORK OFFICE,  
21 and 23 Maiden Lane.



BOSTON OFFICE,  
403 Washington Street,

FACTORY, PROVIDENCE, R. I.

## NEW DESIGNS IN ALL LINES.

ALL OUR SILVER GOODS ARE GUARANTEED 925-1000 FINE.

### THE SPENCER OPTICAL INSTITUTE THE RECOGNIZED OPTICAL SCHOOL FOR BUSINESS MEN

OUR COURSE PRACTICAL COMPREHENSIVE NONCLASSICAL IN THEORETICAL AND APPLIED OPTICS  
SEND FOR APPLICATION BLANK & PROSPECTUS. CLASSES CONVE NE 1ST TUES. EACH MONTH  
SPENCER OPTICAL MANUFACTURING CO. 15 MAIDEN LANE . N. Y.

OUR STUDENTS  
ARE THE  
SUCCESSFUL  
OPTICANS

### BAND RING MOUNTING



DESIGN  
PATENTED  
Sept. 24,  
1895.



**CHARLES KNAPP,**

MANUFACTURING JEWELER,  
41 & 43 Maiden Lane, New York.

SPECIALTY: SUPERIOR LADIES' and CHILDREN'S RINGS



HOLYOKE, MASS., U. S. A.

## CHOICE PAPERS

## PARTICULAR ATTENTION

IS CALLED TO THE NEAT AND RICH  
STYLE OF OUR BOXING. OUR GOODS  
LOOK HANDSOMELY ON THE SHELF  
AND THE QUALITY ATTRACTS THE  
PURCHASER.

TRY THEM.

**PARSONS & GREENE Co.,**  
MANUFACTURING STATIONERS,  
HOLYOKE, MASS.

## Why We Are Leading Locket Sellers.

Our line is most complete—Styles the very newest—We make lockets of all kinds—Gold Lockets, Gold Filled Lockets, Gold Front Lockets, Platinum and Gold Lockets,

Sterling Silver Lockets. We know all about Lockets—have nothing to think of or talk of but Lockets and similar goods. A large line of fobs, flat and drop seals.



Ask your jobber to show you our new Fall lines.

WIGHTMAN & HOUGH CO., Providence and N. Y.

## VACHERON & CONSTANTIN, GENEVA, SWITZERLAND.



FINEST QUALITY OF WATCH MOVEMENTS, FITTING ALL SIZES OF AMERICAN CASES INCLUDING

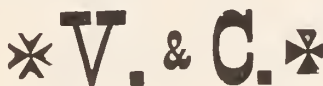

THE NEW FLAT 16 SIZE ELGIN CASES.

EDMOND E. ROBERT,

Agent for the United States and Canada.

REMOVED TO 3 MAIDEN LANE, NEW YORK.

## NEW ORNAMENTS

... IN ...

## STERLING SILVER.



Many Designs in

Galleries, Belt Buckles,  
Belt Slides AND Belt Fastenings,

ALWAYS SOMETHING NEW.

THOMAS W. LIND,

Manufacturer of  
JEWELERS' FINDINGS.

67 Friendship Street,

PROVIDENCE, R. I.



# Standard Sterling Silver Goods.

Belts,

LEATHER, GILT,  
SILVER AND  
SILK WEBBING.

Waist Sets,

Sleeve Links,  
Hat Pins,

IN

Sterling Silver

AND

Rolled Gold Plate.

600 Useful Articles

IN

Sterling Silver.



Foster & Bailey,

Providence, R. I.

NEW YORK,  
SAMPLES ONLY.

CHICAGO,  
SAMPLES ONLY.

ing cup, though the Romans had chalices and large drinking cups such as the Greeks had.

The early Scandinavians having been heavy drinkers, it is supposed in some quarters that the custom of passing around a common drinking cup in an assemblage of people originated with these people. We have seen, however, that the Greeks, in this custom, must have antedated the Vikings, even presuming that the custom obtained among the latter people at all. Paul B. Du Chaillu, in his exhaustive work, "The Viking Age—The Early History, Manners, and Customs of the Ancestors of the English-speaking Nations," does not make this matter altogether clear. However, he translates from the sagas many extracts that show the drinking customs of the

many besides in the hamlet who all drank together during Yule. A short way off was another hamlet. \* \* \* They were to drink during the half of the Yule at each other's farm, etc." The ceremony at the sacrifice was as follows: "Fires were to burn on the middle of the temple floor and kettles to be put on them; the drinking horns had to be carried around the fire. \* \* \* The horn (toast) of Odin must be drunk first, for the victory and power of their king; and then the horn of Njord and Frey, for a good year and peace. \* \* \* Men also drank horns for those of their kinsmen who had been great men; these were called *Minni* (memorial horns)."

The belief in a Valhalla (the hall of the

Fight every day;  
They slay whom they choose  
And ride from the fight  
And sit together well agreeing."

"Every day after having dressed they put on their war clothes and go out into the enclosure and fight and slay each other. This is their game; near day meal, (chief meal, corresponding in time to breakfast), they ride home to Valhalla and sit down to drink.

"There are others that have to serve in Valhöll (Valhalla), carry drink and table-dressing and the beer cups. These are called Valkyrias." No Prohibition party could then have received much support, for it is said in the sagas that even Odin, the God of Gods, did not eat, for wine was to him both food and drink.

In the descriptions of the wedding feasts of the Norsemen no specific mention of the use of a loving cup is made, though drinking formed a prominent part of the ceremonies and recreations. The feasts often lasted a month. The *erfi-öl* (ale or inheritance feast) was a very important ceremony, at which the heir took formal possession of the property of his kinsman. But in this ceremony, the heir took a horn of ale, made a vow, and drained the horn to the bottom. Mr. Chaillu devotes a whole chapter to the drinking customs, feasts and entertainments of the early Scandinavians. Every event above the common in the life of the people, was celebrated by a feast, a fashion which has by no means disappeared from among the Norseman's descendants. Occasionally the women drank together with the men. "Before the tables were put up, the jarl said that the seats would be allotted there, that men and women should drink together, as many as could, but those who were without companions should drink by themselves. \* \* \* Then they drank together, and were very merry that evening, and the next day too." "It was the law of Vikings, even if they were at feasts, to drink in parties. \* \* \* King Grammer told his daughter Hildigunn to make herself ready and carry ale to the Vikings. She took a silver cup, filled it, and went before King Hjöröard and said: "Hail, all Ylfingar, to Hrolf Kraki's memory!" She drank half of it and handed it to Hjöröard."

But to see the loving cup employed with all its real significance we must look into the customs of the people of England. An early form in England of this drinking utensil was



FROM BAYEUX TAPESTRY, SHOWING DRINKING HORNS, BOWLS, ETC., SIMILAR TO THOSE IN EARLY SCANDINAVIAN FINDS.

From "The Viking Age," Copyright by Chas. Scribner's Sons.

early Scandinavians, and from some of these extracts inferences may be drawn that the custom prevailed. In quoting from that portion of the sagas treating of the winter sacrifice called *Vetrarblot*, Oct. 14, he says: "That autumn the news was told King Olaf from Thrándheim that the Thrands had had great feasts during the winter nights; there had been great drinking. The King was told that all cups were hallowed to the Asar, according to ancient custom." "Thorodo was with another man at Thorar's. There was a great Yule-feast, the ale being provided by each one himself. There were

slain), by the Vikings made the people of the North most powerful and skilled warriors. To fall gloriously on a battlefield was held to assure a certain entry to Valhalla; it was a sign of the favor of Odin. This part of the Valhalla faith was so deeply rooted in the minds of the people that it lasted to the very end of the Pagan era, or about the 12th century. Still there was a sameness in the life of the warriors who entered the hall of the slain. They appear to have divided their time between drinking and fighting:

"All the *Einherjar*

In the grass plot of Odin

DORFLINGER'S

AMERICAN

CUT GLASS.



915 BROADWAY  
36 MURRAY ST.  
NEW YORK.

SECURITY PIN GUARD  
PAT'D DEC. 25, 1894  
MANFD BY SECURITY MFG CO. 25¢  
7 ASTOR HOUSE (BROADWAY) N.Y.

85c. doz. Net Cash Discount to Jobbers

ALL KINDS OF  
S KELETON S  
FOR  
SILVERSMITH  
MANUFACTURED BY  
S CHULDER BRO S  
FACTORY AT SOLINGEN, GERMANY. FOUNDED 1850  
545 & 547 PEARL ST., NEAR BROADWAY, NEW YORK



# ROGERS, SMITH & Co.

MADISON SQUARE,  
NEW YORK.

MERIDEN,  
CONN.



## GOLD AND SILVER PLATE.

# CARBORUNDUM

THE GREATEST ABRASIVE YET DISCOVERED.

Four times the Labor and Expense-saving qualities of Emery, Corundum or other abrasives.  
Adapted for Lapidary Work, Grinding, Polishing and every operation where a perfect abrasive is necessary.

### Price List of Carborundum Wheels.

ACHESON'S PATENT, February 28th, 1893; February 26th, 1895.

DIAM. IN.	THICKNESS IN INCHES.																MAX. REV.
	1/4	3/8	1/2	5/8	3/4	1	1 1/4	1 1/2	1 3/4	2	2 1/4	2 1/2	2 3/4	3	3 1/2	4	
1	\$.15	\$.15	\$.20	\$.20	\$.20	\$.25	\$.30	\$.30	\$.35	\$.40	\$.40	\$.45	\$.50	\$.50	\$.60	\$.70	18000
1 1/2	.20	.25	.25	.25	.30	.30	.35	.40	.40	.45	.50	.55	.55	.60	.70	.75	14000
2	.20	.30	.30	.30	.35	.40	.45	.50	.55	.60	.60	.65	.70	.75	.85	.90	11000
2 1/2	.25	.35	.40	.45	.50	.55	.65	.70	.80	.90	1.00	1.10	1.20	1.25	1.40	1.50	8800
3	.30	.45	.55	.60	.65	.75	.85	1.00	1.15	1.25	1.40	1.50	1.60	1.75	2.00	2.20	7400
3 1/2	.40	.50	.65	.70	.80	1.00	1.15	1.30	1.45	1.65	1.80	1.95	2.10	2.20	2.55	2.90	6300
4	.50	.60	.75	.85	1.00	1.20	1.40	1.60	1.80	2.00	2.20	2.40	2.60	2.80	3.20	3.60	5500
5	.70	.85	.95	1.15	1.25	1.60	1.95	2.30	2.60	3.00	3.30	3.65	3.95	4.25	4.90	5.55	4400
6	.95	1.10	1.30	1.55	1.75	2.20	2.70	3.15	3.60	4.10	4.55	5.00	5.45	5.90	6.80	7.70	3700
7	1.25	1.45	1.65	1.95	2.30	2.95	3.50	4.15	4.80	5.40	6.00	6.60	7.20	7.80	9.00	10.25	3160
8	1.50	1.70	2.00	2.40	2.80	3.60	4.40	5.20	6.00	6.75	7.55	8.30	9.10	9.90	11.45	13.00	2770
9	1.80	2.10	2.40	2.90	3.35	4.30	5.30	6.25	7.25	8.20	9.15	10.10	11.10	12.05	14.00	15.90	2460
10	2.15	2.50	2.85	3.45	4.00	5.15	6.30	7.45	8.60	9.75	10.90	12.00	13.20	14.35	16.60	18.90	2210
12	2.65	3.10	3.70	4.50	5.25	6.80	8.40	9.95	11.50	13.05	14.60	16.20	17.75	19.30	22.45	25.50	1850
14			5.05	6.05	7.00	9.00	11.00	13.00	15.00	16.95	18.95	20.95	22.95	24.90	28.90	32.80	1580
16					9.10	11.70	14.30	16.85	19.95	22.00	24.55	27.15	29.70	32.30	37.40	42.50	1380
18					11.25	14.45	17.70	21.00	24.25	27.50	30.75	34.00	37.25	40.50	47.00	53.50	1230
20						17.50	21.55	25.55	29.60	33.70	37.80	41.90	45.95	50.00	58.00	66.00	1100

The wheels are made with a vitrified bond and pressed under hydraulic pressure. Those over three inches in diameter are turned up after firing. The same numbers are used to designate the degrees of fineness, as are used with Emery, and the wheels are made in seven degrees of hardness, marked SSS, SS, S, M, H, HH, HHH, from extremely soft to extremely hard. In ordering, state diameter, thickness, hole, number and hardness.

Hones, Slabs, Files.

CUT THIS OUT.

## THE CARBORUNDUM CO.

WORKS: MONONGAHELA, PA., AND NIAGARA FALLS, N. Y.

the tankard, which then was of considerable size, holding two to three quarts. In order to restrain the intemperance consequent upon drinking from so large a vessel, King Eadgar, (959-975) ordained that pins or nails should be fastened into the cups or horns at stated intervals, and those who should drink beyond these marks should be punished. Thus arose

the day were enjoined by the canons of Archbishop Anselm not to attend drinking-bouts or 'drink to pegs.' The Anglo-Saxons' drinking vessels were usually of horn or glass or sometimes wood, generally ash. This people appear to have had a kind of aversion to clay.

But the direct predecessor of the loving cup



FIG. 1



FIG. 2



FIG. 3

TYGS OF MEDIEVAL ENGLAND.

the famous peg-tankard. The phrase "drink a peg" is used even to-day. Joseph Mayer, F. S. A., in his work "On the Art of Pottery," refers to the same fact as follows: "At no distant period, it was the custom for the whole of the company to drink out of the same vessel. William, of Malmsbury says: 'Formerly the vessels was regularly divided for to prevent quarrels. King Edgar commanded the drinking vessels to be made with knobs on the inside, at certain distances from each other; and decided that no person, under a certain penalty, should either himself drink, or compel another to drink, at one draught more than from one of these knots to another!' One now in the Ashmolean Museum, Oxford, belongs to the 15th century. It is of wood, holds two quarts, and has on the inside a row of eight pins, one above the other. This would give to each person a gill of liquor, the first drinking to the top peg, the second to the next and so on. Mr. Miles says: "It was often arranged, however,

of to-day may be said to be the tyg, a common domestic article of the 16th, 17th and 18th centuries. But before we speak of the tyg, we will devote a little space to its precursor, the cruskin, or cruse or cruske, much in use in the middle ages. References are frequently found to this vessel, as a "crusekyn de terre," and as having, in some instances, been mounted with silver. Usually, however, they were plain cups of earthenware or of wood, generally ash, the latter partaking somewhat of the form of our present basin. Llewellynn Jewitt, in his "The Ceramic Art of Great Britain," says: "I am inclined to think, too, that the pipkin, or porringer, was also called a cruske or cruskin. The term is still in use in Ireland, where a 'cruskin of whiskey' is a common form of expression." Some of the forms of the cruskin, as at present in use in Ireland—made of wood—are shown in the engravings.

The godet, or goddard, was another drinking cup much in vogue at this period, and was

staple manufacturers of the potters of that day. They were the ordinary drinking cups of the period, and were made with one, two, three, four or more handles. Mr. Jewitt says: "The two handled ones are said to have been 'parting cups,' and those of three or four handles 'loving cups,' being so arranged that three or four persons drinking out of one, and each using a different handle, brought their lips to different parts of the rim." Thus is specifically described the loving cup custom as conceived to-day. Specimens of some of the forms of these tugs are shown in this article. Two of these, with three handles each, 1 and 3, were found in a long disused lead mine at Great Hucklow; another, 2, has three handles and a spout, and is ornamented with bosses of a lighter color, being a swan, a flower, and a spread eagle. The two handled cups were of the same general form as those with one handle. These utensils were in brown pottery.

The posset pot was not, as some writers have asserted, a precursor of the loving cup. Though it was passed around the company, each person took only a spoonful in turn. It was used almost universally on Christmas night. A curious mug was in the family of Richard Keys, Burslem. It was a quaint drinking mug, separated by four handles into four compartments, and four persons might use it, yet each drink from his own place.

Mr. Chaffers, in his history of pottery and porcelain, has gathered together a surprising number of allusions to the Flemish "long-beard" from old authors. It was turned out in different sizes, from the great gallon tankard to the 6 inch pint pot. He quotes from Lansdowne a petition of William Simpson, Merchant to her Majesty, Queen Elizabeth, to grant him the monopoly of importing "drinking stone pots," which trade was wholly in foreign lands. Saving the doubtful Elizabethan ware, says Joseph Mayer, F. S. A., in his work "On the Art of Pottery," our native potters had not yet attempted anything more elaborate than the well-known "butter pots" and the three-handled "tygs" of Staffordshire."

(To be continued.)

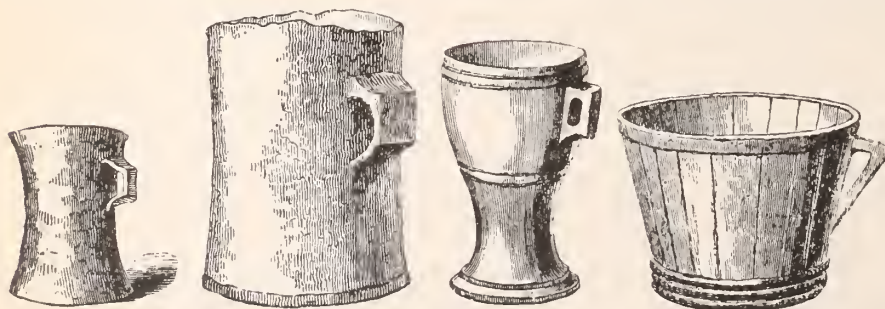

IRISH CRUSKINS OF TO DAY.

that if one drank short of the peg or beyond it he was obliged to drink again, hence if he chose to intentionally miscalculate, he might drink the entire contents. The consequence of two or three such errors can be imagined. In fact, so greatly did the use of the cup increase dissipation that the priests, who appear to have been *par excellence*, the *bon vivants* of

evidently a kind of large cup or bowl, in which spiced liquor was mixed and drunk by gossips and friends.

Thomas Toft and Ralph Toft, of Staffordshire, made at this period among other articles of domestic use, tygs of various forms. Tygs were made in considerable numbers, and indeed appear to have constituted one of the

**W** **GOLD FILLED.** **C**  
**A** **WATCH** **CASES**  
**T** **4K**  
**H** **MONARCH** **S**

FOR RELIABLE OPTICAL & WORK  
SEND TO  
JOS. FRIEDLANDER & BRO.,  
OPTICAL LENS GRINDERS,  
9 MAIDEN LANE, - - - NEW YORK.  
SEND FOR DESCRIPTIVE CIRCULAR OF OUR FRAME AND LENS CABINET.

**CUT GLASS FOR SILVERSMITHS.**



**STANDARD CUT GLASS CO.,**  
545 to 549 West 22nd Street,  
NEW YORK.

**Imports for the Three Months  
Ending Dec. 30, 1895.**

WASHINGTON, D. C., June 20.—The latest published statistics concerning the importing trade of the United States show that during the three months ending Dec. 30th, 1895, this country received jewelry, precious stones, etc., as follows:

Australia, Brisbane—opals and sapphires...	\$1,019 16
Melbourne—opals .....	551 03
Austria-Hungary, Prague—Jewelry.....	375 00
Reichenberg—Jewelry and precious stones.....	68 171 04
Vienna Amber .....	1,351 14
Belgium, Antwerp—Diamonds .....	235,358 56
Ivory.....	9,600 54
Brussels—pearls and precious stones.....	6,023 80
British Honduras—Corals .....	55 50
Cana'a, Clifton—Scrap German silver.....	433 06
Silver plated ware.....	258 00
Fort Erie—Jewelry.....	850 00
Galt—Ivory buttons .....	2,385 00
Pulmerston—Silverware.....	400 00
Port Sarnia—Coins and medals .....	200 00
St. Catharine's—Scrap Platinum .....	180 50
Toronto Jewelers' sweepings.....	2,280 00
Montreal—Jewelers' sweepings.....	5,350 00
Statuary.....	659 50
Chinese vases.....	1,103 00
Sherbrooke—Diamonds.....	1,000 00
Columbia, Cartagena—Ivory nuts.....	1,723 62
Colon—Ivory nuts.....	11,185 16
Tortoise shell .....	537 22
Panama—Ivory nuts.....	1,229 84
Mother-of-pearl .....	16,287 93
Tortoise shell.....	46 78
Denmark, Copenhagen .....	\$ 504 11
France, Dijon—Optical goods .....	438 90
Stones, precious and false. .	80 00
Watches .....	682 10
Paris—Clocks, watches, etc .....	80,953 00
Jewelry and precious stones.....	332,040 00
Optical and scientific instruments .....	118,857 00
Platinum .....	75,496 00
Rheims—Watch crystals .....	1,551 72
Statuary.....	1,240 78
Germany, Augsburg—Watch mainsprings...	2,104 72
Mathematical instruments...	2,037 49
Bremen—Cutlery .....	315,271 98
Optical and scientific instruments.....	30,079 75
Brunswick—Scientific and optical instruments .....	1,192 86
Frankfort—Jewelry .....	1,041 07
Optical goods.....	8,433 57
Platina wire and platinum...	91,722 48
Silverware .....	12,147 67
Frieburg—Clocks.....	11,328 75
Furth—Optical and scientific goods..	2,940 16
Hamburg—Raw ivory.....	11,415 03
Hanover—Scientific instruments.....	806 66
Kehl—Ivory carving.....	267 67
Konigsburg—Amber, raw and ambroid.....	25,055 30
Mayence—Agate ware, jewelry and imitation.....	84,012 00
Munich—Statuary .....	7,126 12
Stettin—Amber goods .....	2,684 43
Stuttgart—Jewelry .....	3,782 03
Weimar—Optical goods.....	3,420 52
Guatemala.—Tortoise shell.....	\$ 385 28
Italy, Carrara—Marble Statuary.....	14,030 70
Alabaster works .....	65 00
Florence—Alabaster Statuary .....	7,322 00
Bronzes.....	526 00
Jewelry.....	255 00
Leghorn—Alabaster works .....	1,765 60
Milan—Statuary .....	820 25
Naples—Bronzes.....	1,512 95
Jewelry .....	148 80
Rome—Bronzes .....	716 70
Marble statuary and pedestals.....	7,665 30
Venice—Jewelry.....	182 00
Mexico, Guaymas—Pearls.....	3,000 00



THIS TRADE MARK MEANS THAT EVERY ARTICLE UPON WHICH IT IS STAMPED, IS **925-1000 PURE SILVER.**

IT ALSO MEANS THAT GOODS SO STAMPED ARE NOT SOLD TO DRY GOODS OR DEPARTMENT STORES, BUT ARE CONFINED TO THE LEGITIMATE JEWELRY TRADE.

NEW YORK,  
CHICAGO,  
SAN FRANCISCO.  
WORKS, PROVIDENCE.

**Gorham Mfg. Co.,**  
SILVERSMITHS.

**E. KIRSTEIN'S SONS CO.,**  
MANUFACTURERS OF  
**Optical Specialties,**  
ROCHESTER, N. Y.  
NEW CATALOGUE NEARLY READY.  
SEND US YOUR BUSINESS CARD.

**COMFORT AND SECURITY**  
ARE COMBINED IN  
**MERRITT'S PATENT EYE GLASS HOLDERS.**  
GOODS ON APPROVAL.  
CORRESPONDENCE SOLICITED.

Made by Merritt, Gargill & Co. Springfield, Mass.

**WHITE'S EYE SHADE.**  
**W. B. WHITE & SON,**  
90 South St., Boston,  
MANUFACTURERS OF  
**Spectacle and Eye-Glass Cases.**  
White's Adjustable Eye Shades and Specialties in Fancy Leather Goods, Etc.  
**CASES MADE TO ORDER.**

**AMERICAN WATCH CASE CO.,**  
11 JOHN STREET, NEW YORK.  
Manufacturers of **FINE SOLID GOLD CASES.**  
**A.W.C.CO** Sold DIRECT to the RETAIL TRADE only.

**DIAMONDS.**  
**Wm. S. Hedges & Co.,**  
 IMPORTERS OF  
**Diamonds and Precious Stones.**  
**DIAMOND JEWELRY.**  
**170 Broadway, New York.**  
 22 Holborn Viaduct, London.

**Alfred H. Smith & Co.,**  
 IMPORTERS  
**DIAMONDS**

AND

**PRECIOUS STONES,**

**182 BROADWAY, COR. JOHN STREET,**  
**NEW YORK.**  
 Venetian Building, **34 & 36 Washington St.**  
**CHICAGO, ILL.**

**BATES & BACON**  
 "FAVORITE"  
 14K

**ALWAYS**

Ask to see  
our

**BATES & BACON**  
 "ROYAL"  
 14K

**GOLD FILLED**

**WATCH CASES.**

**BATES & BACON**  
 "PURITAN"  
 14K

**None Better**

and

**Few Equal.**

**HERMAN KOHLBUSCH, SR.**

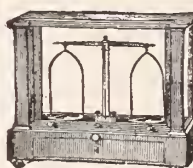

Established 1859  
 Manufacturer of  
**FINE BALANCES**  
**AND WEIGHTS** for  
 every purpose  
 where accuracy is  
 required. 59 Nassau  
 Street, cor.  
 Malden La. N. Y.



Repairs (any make)  
 promptly made.

**SCHULZ & RUDOLPH,**  
 IMPORTERS AND CUTTERS OF  
**DIAMONDS AND OTHER PRECIOUS STONES,**

(Successors to JOHN E. HYDE'S SONS.)

**Sole Agents for The Celebrated Jules Jurgensen Watches.**

**28 JOHN ST. and 65 NASSAU ST., NEW YORK.**

# The Bowden Rings

ARE COMPLETE IN VARIETY, CORRECT  
 IN QUALITY AND PERFECT IN FINISH.  
 WE MAKE EVERY VARIETY OF FINGER  
 RINGS

**J. B. BOWDEN & Co.,**  
**3 MAIDEN LANE,**

NEW YORK

BRANCH OFFICE :  
 206 KEARNY STREET  
 SAN FRANCISCO, CA

La Pas—Pearl shell.....	1,794 64
Mazatlan—Tortoise shell.....	149 12
Nuevo Laredo—Jewelry.....	2,005 00
Paso del Norte—Onyx.....	21 00
Opals.....	158 00
Vera Cruz—Onyx.....	34,590 26
Netherlands, Amsterdam—Diamonds, rough.....	96,892 04
Diamonds, polished.....	51,705 08
Rotterdam—Tortoise shell.....	1,520 00
Russia, Moscow—Bronzes.....	3,070 18
Silverware.....	8,175 41
St. Petersburg—Silver and Gold articles.....	2,828 28
Society Islands—Mother-of-pearl shells.....	11,662 00
Puerto Rico—Tortoise shell.....	1,066 76
Straits Settlements—Tortoise shell.....	3,967 68
Sweden and Norway, Bergen—Silver goods.....	1,319 50
Switzerland, Chaux de fonds—Watches and Watch materials.....	252 650 01
Geneva—Watches and watch materials.....	36,929 15
Jewelry.....	439 60
Turkey in Asia, Jerusalem—Mother of pearl.....	1,476 55
United Kingdom, Dublin—Silverware.....	174 83
Leith—Clocks.....	131 27
London—Clocks and watches.....	10,114 15
Ivory.....	92,924 35
Precious stones.....	252,176 90
Scientific and optical instruments.....	22,412 66
Sheffield—Pearl manufactures.....	9,521 97
Silver goods.....	463 56

### Connecticut.

The clock factory of the E. Ingraham Co., Bristol, shut down June 27th for the month of July.

The Gilbert Clock Co., Winsted, shut down Saturday night to give their employees a two weeks' vacation.

E. A. Bliss, president of the E. A. Bliss Co., Meriden, sailed on June 20 for Paris on a business and pleasure trip.

Charles Roe, traveler for the E. Ingraham Co., Bristol, has returned home from an eight weeks' trip through England, Scotland and Ireland.

D. J. Katz, who went from New Haven to Ansonia, some three months ago, and established a jewelry store in Sperry block has decided to close out his stock.

Fire did \$60,000 damage to the property of the Grilley Co., New Haven, of which Gen. Geo. H. Ford, the jeweler, is president and a prominent stockholder. The loss is about covered by insurance.

At a meeting of the directors of the Waterbury Watch Co., Henry S. Chase was elected a director to fill the vacancy caused by the death of his father, Augustus S. Chase, the late president of the company.

The finance committee of Meriden has voted to abate from \$25,000 to \$8,000 the joint assessment against the Meriden Britannia Co. and the Bradley & Hubbard Mfg. Co. on their reservoir property near Meriden.

A letter from Linius A. Hill, the absconding Wallingford jeweler, posted in New York, was received in Wallingford a few days after his departure. It stated that he was troubled financially and concluded to leave for awhile. His jewelry and watch repairing store is in the Sheriff's hands.

Alderman W. F. Rogers, of C. Rogers & Bros., Meriden, is able to be about, although not to attend to business, after passing through the most serious illness he has had in 20 years. The trouble was a combination of grip, malaria and stomach weakness that threatened for a short time to result seriously.

**Summer Fashions in Jewelry and Silver.**

**A LADY'S RAMBLES AMONG THE JEWELERS\***

The rumor is again afloat that earrings are coming into favor. To the Duchess of York is attributed the revival.

\*

Open-faced watches lead the fashion.

\*

Ebony knobs and handles are of frequent occurrence on silver tea and coffee services.

\*

There are silver bread trays with polished wood centers after the fashion of the gallery tea trays.

\*

Mustard pots of pierced silver are provided with colored glass linings.

\*

A new idea in way of long chains is represented by chains made of finely wrought links of gold and platinum and studded with single small stones.

\*

New and novel are the lemonade spoons with hollow handles, designed to be used in place of straws.

\*

A smart little bicycle bag fitted outside with a watch and inside with a mirror, is among numerous contributions to the fashionable craze.

\*

Decidedly attractive are the pendant watches decorated in the new enamel on silver.

\*

Traveling sets, including belt, bag and purse, are now made to match in all the fashionable leathers. These are light in weight, and mounted in silver.

\*

"Date" jewelry and "Lucky" ornaments are always in more or less demand.

\*

The newest watch for men is thin, open-faced and in a case remarkable for its simplicity.

\*

The spider and its web furnishes the model for a gold and gem brooch.

\*

The miniature belt is composed of a series of miniatures set in gilt or silver and attaching with links of the same metal.

\*

Flexible bracelets afford a twofold purpose, the usual one or, clasped together, a collarette.

\*

Leading silversmiths are making a specialty of reproducing old time tea services for households that are without heirlooms in this direction.

\*

A dragon-fly brooch composed of colored diamonds—brown, yellow and a variety of tints—is decidedly unique.

\*

A desirable tea tray is large and oblong, and has a handle at each end with a coat of arms, crest or monogram in the center.

\*

Turquoise butterflies, made to fasten with a hidden spring to any part of the dress, aid in the craze for gem decoration. **ELSIE BEE.**

ESTABLISHED 1840.

**RANDEL, BAREMORE & BILLINGS**

IMPORTERS OF

**DIAMONDS,**

AND OTHER PRECIOUS STONES

**FINE PEARLS A SPECIALTY.**

MANUFACTURERS OF

**DIAMOND JEWELRY**

A Large Stock of Fine Mounted Goods Constantly on Hand.

Goods Sent on Approval and Insured in Transit.

**Diamonds Cut, Recut and Repaired.**

58 Nassau Street,  
29 Maiden Lane,  
NEW YORK.

1 Tulp Straat,  
AMSTERDAM.

1 St. Andrew's St.,  
Holborn Circus,  
LONDON E. C.

ESTABLISHED 1841.



**CARTER, HASTINGS & HOWE,**

MANUFACTURERS OF

**GOLD JEWELRY,**

**15 MAIDEN LANE. NEW YORK.**

A. CARTER,

C. E. HASTINGS,  
W. T. CARTER,

G. R. HOWE,  
W. T. GOUGH,

FACTORY, NEWARK, N. J.

**WOOD & HUGHES,**  
STERLING SILVERWARE MANUFACTURERS  
New York Agents for the Derby Silver Co.,  
**FINE QUADRUPLE PLATED WARE**  
No. 16 JOHN STREET, NEW YORK  
208 Kearney St., San Francisco, Cal.  
**HASKELL & MUEGGE, Agents.**

**FERD. FUCHS & BROS.**  
**SILVERSMITHS.**  
MAKERS OF STERLING SILVERWARE,  
808-810 Greenwich St., - New York.

### Programme of the National Retail Jewelers' Association Convention.

PHILADELPHIA, Pa., June 27.—The following is the programme of the Fourth Annual Convention of the National Retail Jewelers' Association of the United States, and of the Seventh Annual Convention of the Pennsylvania Retail Jewelers' Association, to be held at Haddon Hall, Atlantic City, N. J., July 14, 15 and 16:

**THE FIRST DAY, Monday, July 14th.**—Convention of the Pennsylvania Association, 10 A. M.; entertainment committee will receive members and visiting jewelers in Haddon Hall, headquarters for both conventions.

The president will open the convention by an address of welcome. Routine business; a specially prepared address by a prominent member on a subject of interest. 1 P. M., session adjourns for dinner.

Afternoon session convenes at 2:30. Address by D. C. Levy, of Philadelphia—"What Constitutes Hard Times for the Retail Jeweler." Routine business until 4; adjournment. Excursion to the Inlet and Brigantine Beach, where the members and visiting jewelers and their ladies will sup.

Evening session will be held at Haddon Hall at 8 o'clock, to be followed upon adjournment by a social reception and smoker.

**THE SECOND DAY.**—9 A. M. Opening of National Convention by national president at Haddon Hall. Presentation of delegates' credentials to national secretary. Roll call of national officers and delegates. Reading of



### YOUR WINDOW DISPLAY.

Is it as attractive as it might be? One or two Rogers Statuettes will add greatly to its interest. Send for beautiful Catalogue. Above depicted group, lists at \$8.00 only.

**ROGERS STATUETTE CO.,**  
441 PEARL STREET, N. Y.

minutes of previous convention.

10.30.—Reports of officers and standing committees. Nominations for National officers to serve on term '96-'97.

12.00.—Recess for surf bath and dinner.

2 P. M.—Afternoon session convenes. Reports of Delegates and presentation of resolutions and recommendations to the convention. Appointment of committee to take these under advisement. Address by W. I. Lewis, president Philadelphia Horological Society—"The Conditions which Render Watch Repairing Profitable." Address by members and visiting jewelers.

3 P. M.—Adjournment. Members and guests and their ladies then embark on board of yacht at the Inlet for ocean sail if wind is favorable. If no wind, visit to Absecom lighthouse or excursion to Longport and by steamer to Ocean City. All Retail Jewelers are respectfully invited to be present.

7.30.—Short evening session. Executive meeting of special committees to prepare reports and recommendations to be acted upon at following morning session. Adjournment at 8.30 to Schauffler's Music Garden.

**THE THIRD DAY.**—9.00 A. M. Delegates and officers reconvene in executive session. Reports of special committees and action on recommendations.

Address by an officer of the New York Jewelers' Association.

12.00—Adjourn for surf bath and dinner.

2.00 P. M.—Afternoon session. Election of National officers for ensuing year. Selection of next meeting place. Address by Nathaniel C. Fowler, Jr., Doctor of Publicity, on advertising for the retail jewelers. Addresses by visitors.

4 P. M.—Adjournment. Afternoon recreation to be announced.

**EVENING.**—7.30. Short business session to finish all unfinished business. Adjournment *sine die*. Grand hop.

The above programme is subject to slight changes as emergencies may suggest. Delegates will come together promptly on time. All resolutions and recommendations from State associations must be handed to the national secretary in writing. All arrangements are in charge of entertainment committee Pennsylvania Association. State associations are requested to have their delegates instructed as to business they desire to have placed before the convention.

#### POETRY ON A PEWTER.

Beer is a compound so adulterate grown,  
As to be hated needs but to be known,  
But foully foaming, at the pint-pot's brink,  
Men first distrust, then dally with, then  
DRINK.

A German genius fills a long-felt want by providing mirrors which will not break. He simply employs celluloid where glass was heretofore used. A perfectly transparent, well polished celluloid plate receives a quick-silver backing like that of a glass mirror. This backing is in turn protected by another celluloid plate which also mirrors, so that practically a double mirror is furnished.

### Annual Meeting of the Alabama Retail Jewelers' Association.

BIRMINGHAM, Ala., June 27.—The annual meeting of the Alabama Retail Jewelers' Association was held yesterday in the rooms of the Commercial and Industrial Association, Montgomery. The meeting went to Montgomery as the choice of a large majority of the members, the choice being ascertained by secretary Wm. Rosenstihl, of this city, by correspondence, some weeks ago.

President E. H. Hobbs, of Selma, called the session to order, and the roll call showed the following members present: W. F. Spurlin, C. A. Nettles, Crowler & Sons, Bascom Dowling, Wm. Rosenstihl & Sons, C. L. Ruth, Wm. Black, Julius A. Weiss, A. Speaker, F. M. Lynch, Rosenstihl Bros., E. Gluck, H. C. Abbott & Bro., Henry Robinson, D. G. Hall, Wm. H. Welch, F. L. Zimmerman, J. C. Welsh, E. H. Hobbs, J. L. Schweizer.

President Hobbs reviewed the actions of the association for the past 12 months, and among other things gave a number of valuable hints as to the further work of the association.

F. L. Zimmerman and Bascom Dowling submitted letters looking to the regulation of the work of repairs and abuses along that line.

Reports of the secretary and treasurer were, after being read, submitted to the committee on finance.

A question of reduction of dues was raised by J. L. Schweizer, and, acting on that suggestion, the dues were reduced to \$1. Funds in the treasury were found sufficient for all present needs.

The election of officers resulted as follows: C. L. Ruth, Montgomery, president; E. H. Hobbs, Selma, vice-president; Julius A. Weiss, Montgomery, 2nd vice-president; Wm. Rosenstihl, Jr., Birmingham, secretary, re-elected; Wm. Welch, Demopolis, treasurer, re-elected; board of directors, J. C. Welch, Uniontown, Bascom Dowling, Ozark, H. J. Rosenstihl, Union Springs, Wm. Black, Montgomery, F. L. Zimmerman, Troy.

President Ruth, E. H. Hobbs and J. L. Schweizer were appointed to draft and submit laws to the Legislature that will be for the benefit of their business.

President Ruth was chosen delegate to the National Association. Bascom Dowling was appointed alternate.

Resolutions were passed thanking THE JEWELERS' CIRCULAR and other jewelry papers for kindness shown the jewelers of Alabama and the State Association in particular. Adjournment was taken till June, 1897, the place of meeting to be chosen by mail ballot of the majority of the members.

Charles H. Munroe, Searsport, Me., has purchased the jewelry stock of Calvin Hewey, Belfast, Me. Mr. Monroe has not yet decided whether or not he will move the stock to Searsport or whether he will come to Belfast. Mr. Monroe is the manager of the company that manufactures gold and silver solder at Searsport. He would like to move the concern to Belfast.

**Death of William H. Williams.**

ALBANY, N. Y., June 24.—William Hart Williams, one of the oldest and most highly respected citizens of this city, died this morning, at 9 o'clock in the home of his son-in-law, Dexter Hunter, Loudonville. Mr. Williams had been ill some months. Last year he passed through a long period of illness, and



THE LATE WILLIAM H. WILLIAMS.

so serious was his condition at one time last Fall that his daughter, Mrs. Hunter, was called from the enjoyment of a European trip to his bedside. He rallied, however, and soon recovered his wonted health.

Mr. Williams was the fifth son of Solomon and Hepzibah Williams. He was born at Berkshire, since renamed Newark Valley, Tioga county, Dec. 10, 1811. His grandfather Azariah Williams, was born in Hartford, Conn., in 1728, and his father was born in Stockbridge, Mass., in 1763. He married Margaret Parsons Foote, daughter of the Hon. John Foote, in Hamilton, Feb. 11, 1835. Of the four children born to them, but two survive, Robert D. and Margaret S., wife of Dexter Hunter. Mr. Williams removed to this city in 1845, and was engaged in the jewelry business ever since, being active until within a short time of his demise. He was one of the oldest business men in this city, and probably was one of the oldest jewelers, in point of experience, in the United States. Mr. Williams was a member of the Masonic fraternity for a number of years, having been raised to the degree of Master Mason in Masters' Lodge, No. 5, on March 17, 1856. He is the second oldest member of the lodge. On Feb. 26, 1866, he was created a Sublime Prince of the Royal Secret, thirty-second degree, Ancient Accepted Scottish Rite.

The funeral services will take place at the home of Dexter Hunter, Loudonville, on Friday morning, 9 o'clock.

**Re-appraisements of Jewelry and Semi-Precious Stones.**

WASHINGTON, D. C., June 25.—Recent re-appraisements before the United States Board of General Appraisers are as follows: 2589-9799, importation of precious stones, in the

form of jewelry, from Bombay, India, received Aug. 15, 1895, invoiced as "Indian Jewelry," entered at \$147.42, and advanced to \$171.56. 2906, importation of precious stones, cut but not set, received from H. J. Schleich, Oberstein, Jan. 14, 1896, invoiced as flat cat's eyes, moonstones, marquise, black onyx, intaglio and tiger stones, on all of which advances to 40 per cent. were made.

**Assignment of Two Bridgeport Firms.**

BRIDGEPORT, Conn., June 26.—This morning two jewelry firms assigned in insolvency and their assignees were appointed by the probate court. The first firm to apply to the courts for the settlement of their business was Breckbill & Benedict. They were represented by Toomey & Lynch, who asked for the appointment of Patrick Coughlin as assignee. The court regarded the petition favorably and appointed Mr. Coughlin. The failure of this firm created a great deal of surprise, and a good deal of sympathy is felt for them. Business has been very poor lately, and the firm have been loaded with goods which they could not dispose of. A number of bills have come due but, while the stock in the store will cover their indebtedness and leave several thousand dollars besides they were unable to raise the necessary amount of money. Both members of the firm are popular.

Yesterday attorney J. T. Lynch made an application to Judge F. B. Hall for the appointment of a receiver but the latter refused to consider the motion as he had a press of other business to attend to. This morning Sheriff Hamilton served a writ of attachment on Breckbill & Benedict for \$500 in favor of Rogers & Brother, Waterbury. The total amount of the firm's indebtedness is \$9,600.

The other firm that had to take a similar course was George F. Stevenson & Son. They assigned to Charles E. Williams and their liabilities amounted to \$6,100. They have been in the jewelry business in this city for the past 25 years, and years ago had the bulk of the business. Lately their trade has fallen off and they moved from their old stand in the Wheeler building across the street to the store formerly occupied by jeweler J. B. Capron. Their assets will not cover the liabilities. They consist of a house and lot in East Bridgeport, which are encumbered, and the stock in the store. One of their heaviest creditors is the Nathaniel Wheeler estate, to whom was owed \$900 for rent.

The newest skirt holder is the Cole Patent Seamless Skirt and Trousers Grip, now offered to the trade in a great variety of dainty and beautiful patterns. The manufacturers of this article, the Tennant Co., 33 Union Square, New York, have already received a large number of orders for the device from leading dealers. The Cole Grip is stamped out of one piece of heavy sterling silver. There are neither rivets, hinges nor loose parts. The grip can be applied in a moment, and holds the skirt and belt securely in position. For men's use this new grip will be found especially suitable. It is made in different sizes to fit all widths of belts.

**NORTHERN PACIFIC RAILWAY TIME SERVICE.**

The rapid commercial and industrial growth of the United States with which the building of railroads keeps a corresponding pace necessitates a system of time service; the transaction of business in all branches and the network of railroads spread over the American Continent has reached such proportions where accuracy of time is of great importance; the method of railroading, the continuous improvements in constructing locomotives, the speed obtained within recent years, and the great number of trains from the Atlantic to the Pacific are phenomenal as compared with those of 15 or 20 years ago. The time when people waited hours for the arrival of trains is a thing of the past. Commerce of to-day has reached such proportions that the business man is kept hard at work at his desk and figures upon a few minutes, or seconds, to reach his destination.

The time service has become a necessity; the protection of life and property demands it; the various transactions in business and the public in general depend upon accuracy of time. It is therefore necessary that railroad companies should adopt a reliable system of time service on their respective roads.

High grade watches without a thorough time system are by no means a safeguard. To obtain satisfactory results the time service should be under the supervision of a competent and responsible man who will devote his time to that particular branch as is done on the Northern Pacific R. R. and every detail in connection with the service to be looked after by such party.

The rules governing the time service on the Northern Pacific are strictly enforced. Their employes are provided with the very best grades of watches and comply promptly with the rules. The Northern Pacific R. R. Co. which ranks among the foremost transcontinental lines has the most efficient time service in the United States and it is to be hoped that other roads will follow their example.

HAVING PURCHASED  
THE ENTIRE  
STOCK OF

**BLOCH AINÉ,**

CONSISTING OF LARGE  
QUANTITIES OF

**Emeralds,**

**Rubies,**

**Sapphires,**

**Whole Pearls,**

**Roses and**

**Diamonds,**

we offer the above goods as  
well as our regular stock to  
the Trade at advantageous  
prices.



**H. Z. & H.**

**Oppenheimer,**

48 & 50

Maiden Lane,

New York.

### Special Agent Gallen's Testimony in the Keck Trial.

It being claimed by Herman Keck, Cincinnati, O., that a part of the report published in THE CIRCULAR of June 10, of the testimony of Special Agent Gallen, of the United States Treasury, given in the trial of Mr. Keck in Philadelphia, was misleading, the examination of Mr. Gallen is printed below, copied direct from the stenographer's report in the possession of the District Attorney, forwarded to THE CIRCULAR from Philadelphia, for this purpose:

John C. Gallen, having been duly sworn, was examined as follows:

BY THE DISTRICT ATTORNEY:

Q. What is your official position?

A. Special Agent of the United States Treasury Department.

Q. Stationed where?

A. At Philadelphia.

Q. Please say exactly what you know in relation to the landing of the *Rhineland*, and of the subsequent landing of the *Aller*?

A. Acting on information received that at the instance of Herman Keck, the captain of the *Rhineland* had endeavored to smuggle diamonds, I met the steamship *Rhineland* upon her arrival here on the 11th day of last February, about 4 or 5 o'clock in the afternoon. I went aboard and examined the passenger list to see if Keck was on board, or anyone under that name, and I also examined the manifest to find if there was any diamonds. I found no one, particularly on the passenger list, corresponding to the name of Herman Keck, and no diamonds appeared on the manifest.

Q. When did the Custom House inspectors get on board the *Rhineland*?

A. The weather was very rough that day and the boarding officers boarded just as she was coming into the dock. I then asked one of the custom inspectors to examine closely the baggage of one or two of the cabin passengers whom I suspected, to ascertain whether they had any large quantity of jewelry, after which I went into the chart-room, where the Captain was with Special Agent Cummings. I spoke of the weather and other topics, and then I said, "Captain," to whom I was unknown, "you have a package for the Coeterman Diamond Company—the Coeterman-Keck Diamond Company, 24 West Fourth street, Cincinnati, Ohio." I repeated the name of the company. He said, "No, I have no such package." I said, "I beg leave to differ with you," and indicating with my fingers, I said, "You have a small package which you received while in Antwerp." He said, "I have a package for Van Reeth, of 21 West Fourth street, Cincinnati, Ohio, and I will give it to you if you have an order for it."

Q. At that time, I understand you to say, he did not know you were a Treasury Agent?

A. No, sir. I was unknown.

Q. Had you ever met him before?

A. Never met him before to know him. I then said, "Captain, I have an order for them." He said, "Show me the order, and I will go

and get the package." I replied, "Captain, I would like to see the package first before delivering the order, and I want to speak to you in private."

Q. Was there anything on your clothes like a badge or anything else, to show what you were?

A. No, sir; none whatever. He was doing some writing at the time, I think finishing the log, and he asked me to wait until he finished, and I said, "Certainly." After the lapse of about five minutes, the Captain arose and said, "You remain here and I can go and get the package." As soon as the Captain left the chart-room, I quietly, and unperceived by him, followed him and saw him enter his room, and just as he emerged he had a package in his hand. As soon as I saw it I said, "Captain, that is the package I want." He said, "Where is your order?" I produced my card as United States Treasury Agent. He refused to let me have it until I was identified as a Custom House officer. A young man was present at the conversation opposite the Captain's room, who represented the Steamship Company—we agreed to go back to the chart-room, where I again insisted upon getting this package—and this young man who represented the Steamship Company, who was present, advised the Captain to give the package to me, which the Captain did. I then searched thoroughly the Captain's room, and also other parts of the vessel, but did not find any other dutiable stuff. After which I went into the chart-room again and opened the package in the presence of the Captain—broke the seal and opened the package.

Q. Did you have any conversation with the Captain as to where he got this package? I mean before this.

A. No, sir; I did not have any conversation with him.

Q. You have told us all that took place up to the time that you broke the seals?

A. Substantially.

Q. I understand you to say that you told him that he had a package for the Coeterman-Keck Diamond Co., and he denied it?

A. Yes, sir.

Q. The Captain mentioned he had a package for Van Reeth?

A. Yes, sir. I broke the seals and opened the package in the presence of the Captain and found it contained diamonds.

Q. Do you know how many diamonds?

A. We counted them the next day at my office, and I think the number was 563.

Q. Were they cut or uncut diamonds?

A. The condition they are in now. I am not a judge of diamonds.

Q. Look at that box and tell me whether that is the box?

A. Yes, sir; that is the box which I seized.

Q. Was the box in that condition, with the exception of the tearing of the paper?

A. With the exception of the tearing of the paper. That paper was around the box, and then there was another seal right in the corner.

Q. It was torn off in the tearing of the paper?



A. Yes, sir.

Q. Was there any address whatever upon the box?

A. No address on the box whatever.

Q. Was there any paper inside of the box?

A. There was a small paper containing twenty-eight diamonds and some writing on it.

Q. Tell me whether or not that is the paper? (Paper shown witness.)

A. Yes, sir; that is the paper that contained the twenty-eight diamonds in the box. Those twenty-eight diamonds were separate.

Q. I understand these diamonds were all in the packages that they are now?

A. Yes, sir. But the twenty-eight were separated from the others.

Q. They were wrapped up?

A. Yes, sir.

Q. Is that the paper they were wrapped in when you opened the box?

A. They were wrapped in finer paper, tisse paper, and then placed in cotton. The twenty-eight were in a separate piece of paper in the same package.

Q. I understand you to say those are not the papers they were wrapped in?

A. I don't think so. It was very soft tissue paper. That one with the marks on contained the twenty-eight diamonds.

Q. The captain was present when the box was opened?

A. Yes, sir.

Q. Did you have any conversation with him as to where he got this package?

A. Not at that time.

BY THE COURT.

Q. Did he tell you anything about the diamonds?

A. Yes, sir; the day before, he did.

Q. That day?

A. No, sir; he did not.

Q. He did not make any explanation?

A. No, sir.

Q. You asked him for the diamonds and you took them?

A. Yes, sir.

Q. Did you tell him why?

A. No, sir.

Q. Did you tell him by what authority?

A. Yes, sir; I told him I was a United States Treasury Agent and this package containing diamonds was not on the manifest.

Q. And you took them, therefore, as smuggled goods?

A. Yes, sir.

Q. You told him that?

A. Yes, sir.

Q. And he did not make any explanation?

A. He said he was no smuggler.

Q. Did he say anything else?

A. Not that day. I did not ask him anything.

BY THE DISTRICT ATTORNEY:

Q. Did he say whether he knew what was in the package?

A. He said he didn't know what was in the package.

Q. Did he say anything when the box was opened and the diamonds displayed?

A. He said he didn't know the contents of that package.

Q. What took place next day?

A. The next day he called at my office and I asked him if he had any explanation to make.

(Objected to.)

THE COURT: His declarations cannot be used against the defendant. What this man said when the diamonds were first found upon him might be evidence as part of the res gestae, and it would be safe to admit it, but what he said afterward certainly is not evidence against this defendant.

BY THE DISTRICT ATTORNEY:

Q. Did the captain give you a description of the man who gave the diamonds to him?

(Objected to. Objection over-ruled. Exception for defendant.)

A. Yes, sir.

Q. What was the day when he gave you the description?

A. The day after I seized the diamonds.

Q. What was the description that the captain gave of the man whom he alleged gave him, the captain, the diamonds?

A. He described him as a man about the size of Collector Reed, not quite as stout, a small, reddish brown mustache, small features, small eyes and blonde complexion.

BY THE COURT:

Q. Did he name the man?

A. No, sir; he could not give me his name.

Q. That is, he did not remember it?

A. He did not remember it.

BY THE DISTRICT ATTORNEY:

Q. That was before you mentioned the name to him?

A. Yes, sir.

Q. Acting on that description and information, what did you do?

A. I went over to New York to await the arrival of the *Aller*, which was due on the 14th of February last.

Q. From what Port does the *Aller* sail?

A. I couldn't say whether it was Antwerp or Bremen; I don't know.

Q. When did the *Aller* get in.

A. She arrived about nine o'clock Friday evening.

Q. Tell us in your own way what took place on the *Aller*.

A. I went down on the revenue cutter about three o'clock in the afternoon from New York and went down the Bay to about Staten Island, a little below where we boarded the *Aller* about eight o'clock. I went into the dining-room and other parts of the vessel to see if I could discover a man answering to the description furnished me by the captain. After a short time I picked out a man corresponding to that description, who was in company with a young man.

Q. Who did you pick out on the captain's description?

A. That gentleman there (pointing to defendant).

Q. You mean the defendant, Herman Keck?

A. Yes, sir.

Q. Had you at that time any information whatever, except the information of the captain, to pick Herman Keck out?

A. No other description whatever.

Q. How many passengers were on the *Aller*?

A. I could not say. I should judge there would be about ninety or about that. I would not be able to say.

Q. You mean ninety first cabin passengers?

A. Yes, sir.

Q. She is a pretty large steamer, is she not?

A. Yes, sir; very large. One of the largest that sails from New York.

Q. Tell us in your own way what you did when you picked out the defendant.

A. I followed him around the steamer, and as he was coming out of the urinal into the corridor leading to the dining-saloon, I went up to him and said "Is your name Keck?" He said, "Yes." I asked him, "Are you acquainted with Captain Loesewitz of the steamship *Rhineland*?" He said, "No." He was not acquainted with the captain. Then I said, "I have a package which I obtained from the captain to be delivered to a man named Keck expecting to arrive at New York on the steamer *Aller*." He said, "I am not the man." I said, "Do you belong in Antwerp or the United States, Cincinnati?"

BY THE COURT.

Q. He said he was not the man?

A. Yes, sir. He said he was not the man. I said I had a package which I obtained from Captain Loesewitz of the steamship *Rhineland* for a man named Keck who is expected to arrive on that steamer. He said, "I am not the man." I asked him if he belonged to Cincinnati or Antwerp. He said Cincinnati. Then I said, "You are not the man I am looking for."

BY THE DISTRICT ATTORNEY.

Q. Did he give his address in Cincinnati at the time?

A. I don't recollect.

Q. Was that all the conversation that took place at that particular time?

A. That is all that took place on the *Aller*.

Q. What took place next? Who was the young man who was with him?

A. I was informed his name was Van Reeth as on of one of the managers of the Coeterman-Keck Diamond Company of Cincinnati, Ohio.

Q. They were traveling together?

A. Yes, sir.

Q. What took place next?

A. After Mr. Keck and his companion's baggage were examined by the custom officers of New York, I took him to a room on the pier and said to him again, "Is your name Herman Keck?" He said, "Yes." There were several custom house officers present there.

Q. Are any of them here?

A. Yes, sir. Mr. Murray was present, Mr. Donohue, Mr. Brown and Special Agent Cummings. He said "Yes." I asked him again if he was acquainted with Captain Loesewitz of the steamship *Rhineland*, and he said he was not. I said, "I received a package containing diamonds in the possession of the captain at Philadelphia on the 11th, and from the description furnished me, corresponding so closely to yourself, I will have to ask you

to come over to Philadelphia on the next train and ascertain if the captain can identify you as the person." He said, "It would not pay me to be engaged in any business of this kind. We are worth \$300,000." I said, "That is true. The captain may possibly want to throw the blame on you and relieve himself."

He said, "Certainly, I will go with you to Philadelphia." I turned around to make preparation to take the next train. Before I finished, Keck turned around and said, "I don't think I will go. I haven't been treated right here to-night." I said, "I am not responsible for that." He said, "I will insist on my rights. You will have to get the necessary papers to take me to Philadelphia."

Q. He said he would require the necessary legal papers before going to Philadelphia?

A. Yes, sir.

Q. Did you have any conversation with him as to who he was, what his business was and where it was?

A. Yes, sir. I turned around then and said to him, "This package"—I held it in my hand that way.

Q. Illustrate to the jury just how this incident happened.

Witness illustrated to the jury by holding box covered with his hand and stated: I held the package in that position in my hand and said to him, after he refused to go with me, I said, "Here is the package which belongs to your firm, the Coeterman-Keck Diamond Company of Cin-

**Here is Something New  
that will Sell Every Day.**

## A SKIRT SUPPORTER That Supports.



Can be applied to any kind of belt in a second and holds garment immovably.

**Supersedes All Other Clumsy Devices.**

**EQUALLY PRACTICAL  
FOR BOTH SEXES.**

Made in plain Sterling, Sterling Gilt and 14K. Gold, of a Uniform Heavy Weight.

**PRICES IN STERLING.**

1 in. \$5.00 per doz.	1½ in. \$7.00 per doz.
1¼ in. 6.00 " "	2 in. 8.00 " "

Rose Gilding, \$2.00 per dozen Extra.

**THE TENNANT Co.,**  
33 Union Square, N. Y.

cinnati." He said, "There is no address on that package."

Q. I want to ask you whether it was possible for him to have seen that there was no address on that package at the time?

(Objected to. Objection overruled.)

Q. Was the package held by you at that time so that Keck could see it?

A. No one could see it. I kept the package in my own pocket. No one saw it but myself.

BY THE COURT:

Q. You had not shown it to him?

A. No, sir.

Q. You had it how in your hand?

A. That way (illustrating). I did not want him to see the package at all.

Q. You say he could not see whether it had an address on it or not?

A. I don't think he could, because my object in holding the package was so that he could not.

BY THE DISTRICT ATTORNEY:

Q. That was your specific object, so that he could not see it?

A. Yes, sir. He said, "There is no address on that package." I said, "That is a good description of the package. There is no address on it." But I said, "The captain was instructed to deliver it to Van Reeth, 21 West Fourth street, Cincinnati, Ohio." He said, "That is a different firm from the Keck Co." I said, "Are you not a member of the same firm with Van Reeth?" He said, "Yes, I am." I said, "Then this package belongs to your firm?" He said, "It does not." I said, "We have the diamonds in Philadelphia and they belong to some one." He said, "I am the only one that has a right to purchase diamonds for either one of those concerns."

Q. What two firms were they?

A. I said the Coeterman-Keck Company and the Van Reeth.

Q. I understood you to say that he admitted that he was a member of the firm of Van Reeth?

A. The same firm as Van Reeth.

Q. You have no doubt about that?

A. No doubt whatever.

Q. You held that box so the palm of your hand would cover at least three sides?

A. Yes, sir. I held it down close to the sides so he could not see it.

Q. Who met Mr. Keck at the dock, if you know?

A. The gentleman who I ascertained to be Mr. Jones, an attorney for Mr. Keck.

Q. A member of the New York Bar?

A. I think he was a member of the Cincinnati Bar.

BY THE COURT:

Q. Where did you meet him?

A. I met him at the pier. Just as soon as Keck walked down and landed on the pier he was met by a person named Jones, Keck's attorney from Cincinnati.

Q. At that time you had not seen Keck?

A. I saw him on the *Aller*, when we boarded her by Staten Island.

Q. How long was that before?

A. We boarded her about 8 o'clock.

Q. You say the man met him at what hour?

A. About 9 o'clock.

Q. Just as Mr. Keck came on shore?

A. Just as he came on the dock.

BY THE DISTRICT ATTORNEY:

Q. On the *Aller* you had not charged him with smuggling?

A. No, sir; not the least.

Q. You had said on the *Aller* that he was not the man you were looking for?

A. Yes, sir. That is right.

Q. Did he state what his business was in Cincinnati?

A. He said his companies were the pioneers of the diamond industries in the west.

Q. Did he make a statement in regard to the amount of diamonds that he had imported into this country?

A. Yes, sir. He said that he had imported into the Port of Cincinnati one hundred thousand dollars worth of diamonds from the first of the year. I said to him, "You are mistaken," that I had a telegram in my pocket in reply to a telegram sent to the Appraiser at the Port of Cincinnati, and that the total amount of his importations of diamonds at the Port of Cincinnati from the first of January to that date did not exceed the value of the assignment which I found in the possession of the captain at Philadelphia, and they were valued at seven thousand dollars. He said, "What are the amounts of my importations?" I said "You know. I am not going to tell you."

Q. You are positive that he said it was through the Port of Cincinnati that he imported the one hundred thousand dollars worth of diamonds since the first of January?

A. There is no doubt about it. From the first of January to date.

Q. Did he give the business address of the Coeterman-Keck-Henrickson Diamond Company?

A. I think he said one was located at 21 and the other at 19 W. 4th St., Cincinnati, Ohio.

Q. When was it that you first saw, and under what circumstances, that slip of paper addressed to F. Van Reeth, 21 W. 4th St., Cincinnati?

A. I first saw that paper at the hearing before Commissioner Bell on the case against Keck.

Q. You did not get it from the captain?

A. No, sir.

Q. Did you see it gotten from the captain?

A. At that hearing.

Q. Who produced it at the hearing?

A. The captain. At the hearing before Commissioner Bell, Captain Loeswitz produced this paper, and that was the first time I saw it.

Q. Did you make any search of Van Reeth's baggage, who came over with him?

A. No, sir; I made no searches of either the baggage of Van Reeth or Keck.

Q. Were you present?

A. I was present, but some distance away.

Mrs. A. E. Hahn, Westerly, R. I., has sold her store to A. L. Castritius.

### Seizure of Precious Stones Claimed to Have Been Smuggled.

PHILADELPHIA, Pa., June 27.—Special agent John C. Gallen, of the United States Treasury, has made a seizure of diamonds. With Special Inspectors John Johnson and Harry A. Chester, he visited the First National Bank of Conshohocken on Monday and seized nearly \$1,500 worth of precious stones. It is alleged that they were smuggled into this country by David Squires, an Englishman and former resident of Frankford. In 1889 he was convicted of smuggling and sent to the Eastern Penitentiary for five years. Since his release from prison he has made several trips to England and landed in Boston on the return voyages with importations of jewelry.

Two weeks ago Squires was arrested on a criminal charge and taken before Justice of the Peace Haywood of Conshohocken. While he was incarcerated there he was visited by his mother, to whom he attempted to give two well filled purses. The purses were intercepted, however, and found to be filled with diamond rings and other jewelry. The goods were deposited at the bank for safe keeping and the special agents of the Treasury Department notified. Squires made a claim that the goods belonged to him and said they were purchased in this city. He gave the address of a jeweler but it was learned that he had only purchased articles worth \$160 there. On being relieved of the criminal charge he made an appointment with Mr. Gallen and he said the whole affair would be fully explained at their meeting. He failed to keep this appointment, however, and is now supposed to be hiding in Canada. After Squires' disappearance the goods were seized and Mr. Gallen is now endeavoring to ascertain how they came to be in this country. The jewelry seized is said to be of English manufacture. There are 15 diamond rings containing in all 108 stones. Fifty-two are ordinary diamonds and the remainder consists of 14 rubies, 20 sapphires, 20 roses, one marquise and one emerald.

### Pennsylvania Opticians Eager to Organize.

PHILADELPHIA, Pa., June 29.—At the inaugural meeting of the Opticians' Association of Pennsylvania, 26 persons signed the roll as members of the organization. The next meeting will be in September, when by-laws for the control of the association will be presented by a committee appointed for that purpose. At that meeting it is confidently expected that the membership will be increased to 50 and some enthusiasts express a belief that before the organization is a year old there will be at least 100 active members.

The object of the organization is to be the elevation and advancement of the profession, the encouragement of opticians to perfect themselves in the study of optics and the scientific adoption of lenses in correcting errors of refraction; and to discourage the hap-hazard and indiscriminate sale of spectacles by irresponsible and ignorant persons.

It was decided that New Jersey opticians should be included in the membership.

### Philadelphia Jewelers Anxious to Play a Baseball Game With New Yorkers.

PHILADELPHIA, Pa., June 30.—What promises to be one of the most interesting baseball games ever played in this country will take place in or near New York early in August. The Jewelers' Club of this city has just authorized President Sackett to organize a baseball team from among the members of the organization, and issue a challenge for a game to be played against a team composed of New York players, and at this early stage the movement has become a vigorous one.

Mr. Sackett is one of the best all-round amateur players in this section and he will captain the team. There are others in the trade who know how to play good ball and now that the "Phillies" are in disrepute the jewelers here are confident that they will soon be able to make the professional players feel envious. The New York representatives will be asked to name a suitable date. Aug. 1 or the following Saturday (Aug. 8), would meet with favor here. The local players will charter a special car and leave Broad St. station for New York on the day the game is scheduled to be played. They will have an abundance of good things with them and by way of encouragement any member fortunate enough to reach first base during the game will be rewarded with a substantial solitaire. There are a dozen players ambitious to cover themselves with glory and mud if necessary should the game be played on a wet day. The New Yorkers will not be restricted in the choice of grounds. Any suitable place within a radius of 20 to 30 miles of that city will be acceptable to the team that represent the Quaker combination.

### Ex-President Curtis, of the Meriden Silver Plate Co., Assigns.

MERIDEN, Conn., June 26.—Robert H. Curtis, until a few months ago president of the Meriden Silver Plate Co., and one of the most widely known citizens of Meriden, made an assignment to-day. A hearing on the confirmation of the trustee named, Benjamin Page, will be held in the Probate court on July 1.

The liabilities are said to be \$60,000 and the nominal assets are estimated to be nearly that sum.

W. A. Ingraham, president of the E. Ingraham Co., Bristol, Conn., left June 26 for Cottage City, where his family is staying during the Summer months.

John Cummings, secretary of the Holmes & Edwards Silver Co., Bridgeport, Conn., has met with a very sad bereavement in the death of his son, W. Edgar Cummings, aged 29 years, who was bookkeeper for the Holmes & Edwards Co., and who died in Philadelphia, Pa., June 26, from the effects of injuries received by falling on the ice several years ago. He had been undergoing treatment in Philadelphia. The funeral took place Monday in Bridgeport. Interment in Lakeview cemetery.

### Last Week's Arrivals.

**THE CIRCULAR** has perfected arrangements for obtaining the names and hotel addresses of all the latest buyers visiting New York, and each day posts in its office, 189 Broadway, a bulletin which every member of the trade is cordially invited to copy.

The following out-of-town dealers were registered in New York during the past week: T. Kaufman, jewelry buyer for Kaufman Bros., Pittsburgh, Pa., 746 Broadway; T. H. Magill, jewelry buyer for T. H. Magill & Co., Troy, N. Y., St. Denis H.; M. L. Carter, Danbury, Conn., St. Denis H.; J. E. Burr, Carbondale, Pa., Grand H.; F. Lewald, Chicago, Ill., Astor H.; B. V. Arnstine, Cleveland, O., Astor H.; S. Shuttles, Dallas, Tex., Astor H.; A. G. Paul, Boston, Mass., Marlboro H.; A. R. Burnham (Reid & Hughes) Waterbury, Conn., Park Ave. H.; G. F. Washburne (Washburne Credit House) Boston, Mass., Broadway Central H.; L. Leiter, Syracuse, N. Y., Hoffman H.; R. A. Kettle, Chicago, Ill., Holland H.; C. C. Offerman, Illinois, Astor H.; A. R. Meyer, Kansas City, Mo., Holland H.; A. M. Rothschild, Chicago, Ill., Holland H.; Mr. Glenny, Buffalo, N. Y., Murray Hill H.; B. Allen, Chicago, Ill., St. Cloud H.; C. J. Bene, Cincinnati, O., Imperial H.; S. Greenberg, San Francisco, Cal., Metropolitan H.; G. E. Wheelhouse, Utica, N. Y., Continental H.; W. L. Hoskins, Oswego, N. Y., Grand H.; C. Weichel, Scranton, Pa., Westminster H.; S. Aloe, St. Louis, Mo., Hoffman H.; M. Bauman, St. Louis, Mo., Marlboro H.

### Trans-Atlantic Voyagers.

#### TO EUROPE.

Herman Keck and F. Von Reeth, of the Coeterman-Henrichs-Keck Diamond Cutting Co., Cincinnati, O., sailed Wednesday on the *Friesland*, for Europe.

R. F. Polack and wife, York, Pa., will sail July 4th, for an extended trip through Europe.

Mr. and Mrs. C. A. Keene, Boston, Mass., will sail from New York, July 4th, on the *Lucania*, of the Cunard Line. They will be absent about two months on a pleasure trip to London, Hamburg, Paris, the Alps and many other European points.

Thos. Chadwick, New York, and Chas. P. Hansel, of Hansel, Sloan & Co., Hartford, Conn., sailed Saturday on the *Umbria*.

Albert Lorsch, of Albert Lorsch & Co., New York, accompanied by Mrs. Lorsch and Miss Elsie Lorsch, and J. F. Crane, of Mandeville, Carrow & Crane, Newark, N. J., sailed Saturday on *La Bretagne*.

#### FROM EUROPE.

S. Konijn, B. Konijn and Mrs. Konijn, and Mr. and Mrs. Paul E. Treibs, of Treibs Bros., New York, arrived last week on the *Lucania*.

J. Muhr, of J. Muhr & Bro., Philadelphia, Pa., arrived last week on the *St. Paul*.

Andrew Linton is enjoying a trip to Europe. He will be absent several months.

## Ten Sterling Silver Demurrers Sustained and two Refused.

Judge Fitzgerald, of the Court of General Sessions, New York, in a decision handed down Monday sustained the demurrers of the proprietors of 10 of the 12 department stores indicted in May, 1895, for violating the Sterling Silver law. The demurrers are sustained on technical grounds, there being a flaw in the indictments which did not allege that the word "sterling" on the articles denoted that they were .925 part pure silver.

Judge Fitzgerald in his opinion holds the law not unconstitutional. Two of the indictments, against Bloomingdale Bros. and Jno. Daniel & Son, did not contain this error, so the demurrers interposed by these firms are overruled and these firms will have to stand trial. The full text of Judge Fitzgerald's decision is as follows:

Court of General Sessions of the Peace for the City and County of New York.

No. 1. The People of the State of New York  
against

Charles P. Webster, Isidor Straus and Nathan Straus.

No. 2. The People of the State of New York  
against

John M. Hughes, Albert B. Hilton and Frederick Hilton.

No. 3. The People of the State of New York  
against

Isaac Stern, Benjamin Stern and Louis Stern.

No. 4. The People of the State of New York  
against

Albert F. Jammes.

No. 5. The People of the State of New York  
against

Henry C. F. Koch and Adolph Riesenber.

No. 6. The People of the State of New York  
against

Geo. A. Hearn, Arthur H. Hearn, Geo. S. Schanck and Clarkson Cowl.

No. 7. The People of the State of New York  
against

Hugh O'Neill.

No. 8. The People of the State of New York  
against

Samuel Adams and John Flanagan.

No. 9. The People of the State of New York  
against

James Simpson and William Crawford.

No. 10. The People of the State of New York  
against

Samuel Ehrich and Julius Ehrich.

### APPEARANCES

Horace Russell, Esq., for defendant Hilton & Hughes; Frederick R. Coudert and Chas. E. Adams for other defendants.

Hon. John R. Fellows, District Attorney and Assistant District Attorney Geo. Gordon Battle, for the people.

Fitzgerald J. Demurrers have been interposed in all the above entitled actions, and as a decision upon the first two practically disposes of the others, I will consider the different points raised by the counsels as applying to each and rule upon all for the reasons set forth, as determining the two cases under immediate consideration. The statute alleged to have been violated, reads as follows: "Penal Code, section 364-A. A person who makes or sells or offers to sell or dispose of, or has in his possession, with intent to sell or dispose of, any article of merchandise marked, stamped or branded with the word 'sterling' or 'sterling silver,' contained or enclosed or inclosed in any box, package, cover, wrapper or other thing in, by or which said article is packed, inclosed or otherwise prepared for sale or disposition having thereon any engraving, printed label, stamp, imprint mark or trademark, indicating or denoting by such marking, stamping, branding, engraving or printing that such article is silver, sterling silver or solid silver, unless nine hundred and twenty-five one-thousandths of the component parts of the metal of which the said article is manufactured is pure silver, is guilty of a misdemeanor."

Each of the indictments contains two counts, the first count charging that the defendant did "unlawfully sell, offer to sell, and dispose of to the person mentioned therein, a certain article of merchandise described therein, which said article of merchandise was then and there marked, stamped and branded 'sterling' nine hundred and twenty-five parts of the metal of which the said article was then and there manufactured, not being then and there pure silver."

The second count charges the defendant with "having in his possession, with intent to sell and dispose of the same, some article of merchandise, which said article was then and there marked, stamped and branded with the word 'sterling' nine hundred and twenty-five one-thousandths of the component parts of the metal, of which said article was then and there composed not being pure silver."

It is contended that the indictments are demurrable on three grounds:

First, upon the ground that the statute is unconstitutional, because in the case of all persons who had silverware of the sort described in their possession when the act took effect its operation must be to confiscate such silverware, and so it deprives the owners of their property without due process of law.

Second, on the ground that the indictment fails to charge guilty knowledge or criminal intent.

Third, on the ground that the indictment fails to specify that the word "sterling" indicates and denotes that the said articles was then and there sterling silver.

It is claimed that the statute is unconstitutional, and that its enforcement would result in confiscation; that a person who had in his possession with intent to sell or dispose of any of the merchandise which this act declared unlawful, even though he had lawfully acquired it, became *eo instante* guilty of a misdemeanor. While not feeling called upon to determine upon the demurrer, the question of the constitutionality of the act, still in view of the vigor and earnestness with which this point is pressed, I must say that a careful examination of the authorities submitted, leads me to the conclusion that the act in question in no way violates the restraints of the constitution. It is argued that the statute fails to exclude from its operation, but on the contrary affirmatively includes within such operation, the case of every person who at the instant the law went into effect, had in his possession with intent to sell or dispose of, any of the articles mentioned in the sec-

tion. There is no question of the fact that possession with intent to sell was lawful before the passage of this section. The failure to exclude previous possession from its operation when simple possession (unaccompanied by intent) is made criminal; is very different from failure to where an act is declared criminal only when accompanied with particular intent. The case of the People against Weinheimer, in the 13th, New York, mainly relied upon by the defendants, does not, in my opinion, support their claim. The mere possession (of liquors), innocent of any intent to sell (except for specific uses), elsewhere than in a dwelling house, was made criminal by the act then under consideration. and Judge Hubbard says at page 455:

"I have examined the first section of the law with care, to see if it could be construed in such manner as to make the keeping in any place except a dwelling house criminal only *when accompanied with an intent to sell,*" and Judge Selden, in the same case, at page 435 uses the following language:

"It is not sufficient that they impair the value of the property in ever so great a degree, because this destroys no right. It leaves to the owner, unimpaired, his right to keep, to use and dispose of the article. It does not, therefore, deprive him of any right of property. All regulations of trade, with a view to the public interests, may, more or less, impair the value of property, but they do not come within the constitutional inhibition unless they particularly take away or destroy those rights of which property consists. Its destruction must be for all specific purposes, total, not that a merely colorable preservation of some minute and trifling interest would uphold the act. The substantial right of property must be saved, and the provisions must be such as may easily be considered as intended to regulate, rather than subvert and destroy property."

The provisions of the section now under consideration are such as to *regulate* rather than *subvert and destroy* property. It is an exercise of the police power of the Legislature to prevent frauds upon the public by requiring that all silverware so marked shall contain a fixed quantity of silver. The effacement of the mark from such merchandise previously acquired may impair its merchantable value, but it cannot be held that by this act the property is destroyed, or the owner deprived thereof without due process of law. *Berthoff v O'Reilly*, 74 N. Y., 509; *In re Jacobs*, 98, N. Y., 98; *People vs. Marks*, 99, N. Y., 377.

Neither do I think that the second ground upon which the demurrers are submitted is a tenable one. It is sufficient that the indictment follows the language of the statute defining the crime, or that words of similar import are employed.

It is well settled that an indictment for a statutory offense charging facts constituting the crime in the words of the statute, and containing averments as to time, place, person and other circumstances to identify the particular transaction is good as a pleading, and justifies putting the defendant on trial. *People vs. West*, N. Y., 295, *Whartons Criminal Law*, Section 364, *People vs. Taylor*, 3 Denio, 391.

The rules of criminal pleading require that the indictment must state facts constituting the offense.

When an indictment is framed upon a statute, it must state all the circumstances which constitute the definition of the crime in the statute, so as to bring the accused precisely within it. *People against Williams*, 92 of Hun 354.

As the learned counsel for the defendants, Hilton, very forcibly expresses it in his brief, "The sale of a steel scissors with the word 'sterling' upon it, could not reasonably be construed into a violation of the section," and yet if these indictments were held to be

good all the allegations they contained could be established on just such facts.

The learned District Attorney was evidently misled by the punctuation into deeming the words "indicating or denoting by such marking, stamping, branding, engraving or printing, that such article is silver, sterling silver or solid silver," as only applying to the latter clause of the section following the semi-colon in the fourth line, but in my judgment the correct interpretation of the whole section would hold it applied equally to articles mentioned in the first clause; as to "package, box, cover or wrapper containing such articles," as mentioned in the second clause. Punctuation is in no case controlling upon interpretations. (Bishop on Statutory Crimes, Section 78).

The purpose and essence, the only conceivable reasons for such an enactment are that it was intended to prevent fraud and imposition. Its object is to protect the public from deception, to guard them against the snares of the wily trader, who might seek to lure a purchaser into the belief that he was getting an article of standard value when, in fact, he was only receiving one of an inferior kind.

As the defect in the indictments is a material one, the demurrers must be allowed.

Judge Fitzgerald's decision on the two demurrers which he overrules is as follows:

Court of General Sessions of the Peace for the City and County of New York.

People of the State of New York  
against  
John Daniel, John Daniel, Jr.,  
and Geo. J. Daniel.

People of the State of New York  
against  
Lyman G. Bloomingdale and  
Joseph B. Bloomingdale.

FITZGERALD, J. As these indictments are free from the material defect referred to in the opinion of the court disposing of the other cases, the court overrules the demurrers therein, with leave to the defendants to plead over.

At the office of Frederick R. Coudert, general counsel for the indicted dry goods men, a CIRCULAR reporter was told that the law firm believed an appeal would be taken from the decision overruling the indictments against Bloomingdale Bros. and Daniel & Son, and an attempt made to have the appellate term of the Supreme Court declare the law unconstitutional.

DeLos McCurdy, counsel for the silversmiths indicted at the instigation of the drygoods men, was seen by a CIRCULAR reporter, Monday, and questioned as to effect the decisions of Judge Fitzgerald would have on his cases. Mr. McCurdy said that as the department store indictments were dismissed not upon the unconstitutionality of the law, but owing to a technical error which did not appear in the indictments charging his clients with the same offense, the dismissal could have no bearing on his cases, except to expedite the trials as it leaves the District Attorney no excuse for delaying them any longer.

Assistant District Attorney Unger, who has charge of the calendars of the various parts, was asked by a CIRCULAR reporter if the silversmiths' cases would now go to trial. He could not yet tell when they would come up, as he saw no opportunity of putting the cases on at present. All the calendars, he explained, were choked with cases of people who were in the Tombs without bail, as the prison cases are given preference every Summer. Col.

Fellows had notified him to advance the silversmiths' cases as soon as Judge Fitzgerald's decision was handed down, but that order was given nearly two months ago, before the rush began.

**The Forthcoming Meeting to Organize a Jobbers' Association.**

The invitations sent to the jobbers in American watches to attend a convention for the purpose of discussing the proposition to form a new jobbers' association were sent out last week. The date of the convention as announced in THE CIRCULAR last week will be July 15th. It will be held in the banquet hall of the Café Savarin, New York, the home of the meetings of the old National Association of Jobbers in American Watches. The call to the jobbers reads as follows:

New York, June 24, 1896.

Gentlemen:—You are cordially invited to attend a convention of the jobbers of American watches in the United States to be held in the Banquet Hall of the Café Savarin, in the Equitable building in this city on Wednesday, July 15, 1896, commencing at 10 A. M.

This convention is called in response to a strong desire among the jobbers for an opportunity to come together and discuss the present condition of the American watch business, and, if possible, to secure such changes in the methods of conducting the same, as will make it more satisfactory to all concerned.

The convention is not committed to any particular plan, but the one which was drawn up for the New York jobbers Hon. Elihu Root will be brought before the meeting, and any other plans or suggestions which may be offered by any jobber present, will be welcomed and will receive due consideration.

If you desire to secure a reasonable return for the expense and risk of handling watches, do not fail to attend the convention; or, if you find it impossible to be present, give your proxy to some one who will be there and will act in your interest, and in the meantime, please give the general subject your careful consideration, that you may be ready to act upon the important questions which will come up for settlement.

Yours truly,  
A. V. HUYLER, (N. H. White & Co.),  
E. S. SMITH, (Smith & North),

Committee.

**THE TORONTO JOBBERS DIVIDED IN THEIR VIEWS.**

TORONTO, Can., June 27.—The proposed plan for a new association of American watch jobbers has hitherto excited but little interest among the trade here. While all are disposed to admit the desirability of some more effective restraint upon reckless competition than at present obtains, most appear to be doubtful of the efficacy of the proposed scheme. The general opinion appears to be that if any effective check is to be placed upon the cutting of prices it must be by the action of manufacturers rather than the jobbers.

Walter J. Barr, manager of the Goldsmiths' Stock Co., said: "I do not think it will be effective; the manufacturers should diminish materially the number of wholesalers with whom they do business. They should map out the territory determining from their experience the number of agents sufficient to supply that territory with their goods. The manufacturers have displayed a short-sighted selfishness in conducting their business without any regard to the permanent stability of those hand-

ling their goods. The only adequate remedy for the existing state of things would be to curtail production and limit the number of agents. The proposed scheme throws upon the jobbers the responsibility which rightly belongs to the manufacturer."

M. E. Ellis, of P. W. Ellis & Co., said: "I don't consider it practicable. The weakest point is the fact that it seems to allow an unlimited number of commissions and rebates—at least the wording implies such allowances in excess of the regular discounts. It should be the fundamental principle of such an association to treat all alike. The fact that it exposes the whole of a merchant's business, disclosing the amount of his purchases, is an objectionable feature, as many business men have a decided aversion to allow competitors to know what they are doing. The weak point in the former association is not overcome, large purchasers for the retail trade being placed on the same level with jobbers. The safeguards outlined are insufficient to compel those who do not adhere to their agreements made with the association to keep faith. Our feeling is that in the absence of arrangements which would absolutely insure the carrying out of agreements we would much prefer to control our own business to suit ourselves. We believe any movement to correct the disastrous cutting of prices must come from the manufacturers, who can regulate the sale by selling only to those jobbers who carry on business satisfactorily on terms specified by themselves."

Edmund Scheuer:—"An association would be beneficial to manufacturers, jobbers and retailers alike, as the keen, almost insane competition among all classes of dealers in watches has reduced the watch trade to a very unprofitable one. The success of an association of the kind would entirely depend upon the co-operation of all manufacturers interested and it could only be put on a sound, healthy basis by their faithful observance of its provisions."

A. C. Anderson, of A. C. Anderson & Co.:—"I see no objection. It seems to be a feasible plan, much more simple than others and more easily worked out. No doubt an association is needed very badly. The fact of the matter is that most of the retailers who are able to pay cash get watches at about the same prices as jobbers. We have no protection at all, each trying to out-do the other in giving customers the most of our profits. I am favorable to the formation of an association on a basis just as strict as the laws will allow."

S. Frenkel said:—"There is no question that such an association is badly needed. Something is necessary to rectify the evil of departmental stores buying direct from the manufacturer, but I am disposed to doubt whether in a time of depression like the present any effective way of limiting cut-throat competition can be found. Every one wants to get some special advantage in the way of rebates, etc., and the thing has become so universal that it is difficult to see what remedy can be applied, especially as the law against combines stands in the way."

### Boston.

The American Waltham Watch Co.'s factory is closed for the annual Summer vacation.

Reginald C. Robbins, who is commodore of the Beverly Yacht Club, is on a cruise in Buzard's Bay.

A. E. Fisk, head of Smith, Patterson & Co.'s diamond department, returned last week from a fortnight's vacation.

Austin T. Sylvester attended the reunion of the Third Army Corps veterans, of which body he is a prominent member, at Portland, Me., Thursday.

Fred C. Graves is the latest member of the jewelry trade to join the ranks of the yachtsmen. He has just received from the builders a 33-footer, sloop rig, and will sail her from Winthrop this season.

The E. B. Floyd & Co. Corporation have incorporated with a capital stock of \$10,000 in single shares of \$100, to do a wholesale and retail business in watches and jewelry. Jere Taylor, Eng. B. Floyd and Albert Roscoe are the promoters.

Henry W. Patterson sailed Monday, June 29, accompanied by Mrs. Patterson, for London, being a member of the Ancient & Honorable Artillery Company, of Boston, which is to be the guest of the London namesake of the organization during the month of July.

July 4th Charles F. Morrill, as commodore of the South Boston Yacht Club, will lead a big fleet of harbor craft on a yachting cruise along the New England coast to the eastward, probably going as far as Portland, Me. The trip will be planned to cover a period of 10 days.

A. H. Brooks, known to the trade as an expert watchmaker, having been for a number of years in the employ of the American Waltham Watch Co., Waltham, and previous to that time with William Davis & Son, London, has taken charge of the repair department at C. A. Keene's establishment.

F. W. Ruggles, whose X-ray photographs are attracting a great deal of attention in this vicinity on account of their perfection of detail and also by reason of the fact that the apparatus for taking the pictures is his own construction, lectured one evening last week at Hudson, Mass., on the subject before an interested company of people.

James W. Tufts contemplates removing his silverware and fountain factory to much larger quarters in a building to be erected in the near future on Atlantic Ave., this city. The structure is to have a frontage of 180 feet on Congress St., and run to Fort Point channel, where wharf space will be obtained. It will be six stories high and the available floor space will be about 170,000 square feet. A long lease of a large part of the building has been taken in advance of its construction, and it will conform to the requirements of the future occupants in all important details.

---

### Pittsburgh.

Leo. G. Weil will shortly go on the road for Fred Kaufman, New York.

The American Swiss Watch Case Co. have

opened an office in room 43, Eichbaum building.

The Grogan estate sold a frame house, with lot 22 x 100, on Frazier St. near Boquet, for \$1,200.

Charles Holyland, with G. B. Barrett & Co., was married to Miss Margaret Taylor, of Allegheny, June 30.

Harry Roberts, a messenger boy employed by B. E. Arons, decamped with \$183, and has not been located.

A. E. Siedle has closed a deal with Sarah Kennedy for the two lots on the east side of Hailman St. Together they are 53 x 138 feet, and cost \$4,000.

Charles Weinhaus & Sons, jewelers' auctioneers, have charge of the auction sale of the World's Fair Japanese exhibit, purchased by Shuman Bros.

C. C. Corcoran furnished the team trophy for the Pittsburgh-Cleveland road race. The trophy is a superb one, worth \$250, and the cup is 29 inches high with a diameter of 19 inches.

Visiting jewelers in Pittsburgh, Pa., last week were: Adam Fisher, Greensburg, Pa.; R. H. Wolfe, Smithton, Pa.; J. C. Rhodes, Homestead, Pa.; C. C. Marsh, Sistersville, W. Va.; H. H. Weylman, Kittanning, Pa.; Frank Worrell, Washington, Pa.

As a delegate to the International League of Press Clubs, THE CIRCULAR correspondent visited the wonderful plant of the Carborundum Company, at Niagara Falls. A box of carborundum and a whetstone were carried away by each guest as a souvenir of the visit.

A plate glass show window of Emanuel De Roy's store, 643 Smithfield St., was broken by a small missile and \$200 worth of rings and badges was stolen. This is the second attempt made to rob stores in this manner. The police here protest against the practice of leaving valuable goods in the show windows over night.

J. W. Hull & Co., Grafton, W. Va., assigned last week. Many local firms are interested.

The Pittsburgh correspondent of THE CIRCULAR made a brief call upon Webb C. Ball, Cleveland, O., last week. Mr. Ball reported a satisfactory trade, owing to numerous conventions held there. He has enlarged his floor space 30 feet, which addition will be devoted to silver.

Hardy & Hayes have presented to the Carnegie Art Gallery a work of art that is eminently appropriate to adorn a Pittsburgh collection. It is a bronze bust entitled "Hiawathe," depicting the head and shoulders of a typical Indian chief. This bust was made by Mr. Koenig, a German sculptor now in Philadelphia, and is the only work of this kind produced by Mr. Koenig.

---

### Philadelphia.

Harry Schimpf and his family have gone to Atlantic City for the Summer.

Driesbach & Co., opticians, have associated with H. R. Smith, 1610 Susquehanna Ave.

The Presentation Watch Co. is the name of a new concern at 1312 Filbert St.

James W. Brath, lapidary and dealer in precious stones, has opened an establishment at 1346 Chestnut St.

Charles B. Lynch has his family located at Sea Isle City, where he has a cottage. Mr. Lynch is vice-president of the Property Owners' Association at that resort.

The excavations are being made for Hamilton & Diesinger's new building on Chestnut St. above 12th St., and it is expected that the structure will be ready for occupancy in the Fall.

The plant of the Ledig Mfg. Co., 248 N. 8th St., which was recently partly destroyed by fire, is about to be rebuilt, and the owners are taking estimates on some building materials.

Walter Eakins, junior member of George Eakins & Son, left June 22 for California. He will reside permanently at Los Angeles, to which place his father, George Eakins, will also remove as soon as he closes out business.

Jacob Muhr, who left Southampton on the *St. Paul*, June 20, reached his Chestnut St. office at 12:30 o'clock, June 27, just 30 minutes before closing time. The attaches of the office, who were preparing for a Saturday half-holiday, extended a hearty welcome on his return from abroad.

While riding a bicycle last Saturday evening, Arthur Kampnan, jeweler, Germantown, received serious injuries. It was shortly after 8 o'clock, while he was riding his bicycle on School Lane, near the township line, he collided with a wagon driven by a Mr. Steel, and was thrown violently to the ground. He was quickly removed to his home, where several doctors were called in, and it was found that he sustained a fracture of three ribs, and was injured internally.

---

### A Permanent Receiver Appointed for Newwitter & Rosenheim.

Judge Andrews, of the New York Supreme Court, Friday signed a decree in the suit by Morris J. Newwitter against his partner, David Rosenheim, to dissolve the partnership of Newwitter & Rosenheim, jobbers of jewelry, 513 Broadway, New York. The suit was commenced May 8th, and Philip Rosenheim was appointed temporary receiver of the firm. Judge Andrews' decree dissolves the firm, appoints the temporary receiver permanent receiver with the usual powers, and names John H. Judge referee to take account of what is due to the parties to the action and report what dividend shall be paid to the creditors.

---

Monroe Engelsman, the well known partner of the firm of Louis Weil & Co., has succeeded to the diamond cutting and importing business of that firm, which he now conducts under his own name. Mr. Engelsman has just returned from Europe, bringing a quantity of new goods which he is placing before the trade. One of his importations includes 1,000 karats of large diamonds which will be ready about July 10th.

# The Jewelers' Circular AND HOROLOGICAL REVIEW.

PUBLISHED EVERY WEDNESDAY BY  
**THE JEWELERS' CIRCULAR PUB'G CO.,**  
189 BROADWAY, NEW YORK CITY.

A JOURNAL DEVOTED TO THE INTERESTS OF JEWELERS, WATCHMAKERS, SILVER-SMITHS, ELECTRO-PLATE MANUFACTURERS, AND ALL ENGAGED IN KINDRED BRANCHES OF INDUSTRY.

Member of the American Trade Press Association.

Our Editorial columns will contain our own opinions only, and we shall present in other columns only what we consider of interest or value to our readers. Advertising matter will not be printed as news.

Advertising rates in THE CIRCULAR are lower, considering the number of tradesmen reached by its large circulation, than in any other jewelry journal.

Notices of changes in standing advertisements must be received one week in advance; new matter can be received up to Monday.

## INFORMATION FOR SUBSCRIBERS.

### Terms of Subscription, Postage Prepaid.

United States and Canada, - - -	PER ANNUM.	\$2.00
Foreign Countries in Postal Union, - - -		4.00
Single Copies, - - - - -		.10

New Subscribers can commence at any time.

Payments for THE CIRCULAR when sent by mail, should be made in a Post-Office Money Order, Bank Check or Draft, or an Express Money Order or Registered Letter. All postmasters are required to register letters whenever requested to do so.

Pay money only to authorized collectors having proper credentials.

**Returning Copies** Returning your paper will not enable us to discontinue it, as we cannot find your name on our books unless your address is given.

**Changing Address.** In changing address always give the old as well as the new one. Your name cannot be found on our books unless this is done.

**Discontinuances.** We will continue to send papers until there is a specific order to stop, in connection with which all arrearages must be paid; but such an order can be given at any time, to take effect at or after the expiration of the subscription. All such orders will be promptly acknowledged by mail.

**Liability.** The Courts have decided that all subscribers to Journals are responsible until arrearages are paid in full and an order to discontinue has been received by the publisher.

## THE JEWELERS' CIRCULAR IN EUROPE.

Among the Places in Europe where THE JEWELERS' CIRCULAR is on file are the following:

**LONDON**—First Ave. Hotel, Holborn, E. C.; Holborn Viaduct Hotel, Royal Hotel.

**PARIS**—Hotel de L'Athénée, Rue Scribe.

**BERLIN**—Deutsche Uhrmacher Zeitung, Jager-Strasse, 73.

**GENEVA**—Journal Suisse D'Horlogerie.

**AMSTERDAM**—Continental Club, Hotel Amstel.

**ANTWERP**—Diamond Club, Rue de Pelican.

Vol. XXXII. July 1, 1896. No. 22.

Every line of reading matter in THE JEWELERS' CIRCULAR, with the exception of the few brief extracts from exchanges, always properly credited, is written exclusively for this journal. Each issue of THE JEWELERS' CIRCULAR is copyrighted. Permission to quote is extended to other publications, if such quotations are properly credited.

## Possible Increased Diamond Tariff in Canada.

Parliament of an increased tariff on diamonds a possibility of the near future. That there is a disposition on the part of the Liberals to effect this change may be inferred from the following letter from one of Canada's foremost jewelry firms:

MONTREAL, Can., June 26th, 1896.

Editor of THE JEWELERS' CIRCULAR:

We are anxious to lay before our Minister of Customs any information we can give on the results of the duty on diamonds in your country. We noticed some time ago that you published several articles on this subject. May we ask you to let us have copies of anything published on this subject and send us the account for same and we will gladly pay.

Yours truly,  
HENRY BIRKS & SONS.

We gladly forwarded to Messrs. Birks & Sons a number of copies of THE CIRCULAR, and as our many friends in Canada may desire to be posted in the same facts sought for by this firm, we will review the contents of these numbers bearing upon the evils of the present United States diamond tariff: Copies of Jan. 8, 15, 22 and 29, and Feb. 5 and 19, 1896, contain a long series of letters from prominent importers and dealers in precious stones throughout the country, in which they give their impressions of the evils of the present diamond tariff of the United States. These copies of THE CIRCULAR have been submitted by the diamond trade to the Treasury Department, and have received much consideration, the Treasury Department officials conceding that the claims of the importers and dealers are sound and reasonable. This series of letters has furnished the most effective argument to the advocates of a low tariff on precious stones. On page 20, Feb. 5th, 1896, is a report submitted to the Treasury Department by the Appraiser of Customs in New York, Mr. Bunn, in which he calls attention to the great loss of revenue to the Government through the increased duty on diamonds; also an interview with Mr. Bunn by one of THE CIRCULAR's representatives. This report was a stunning blow to the advocates of a high tariff on diamonds. On page 21, Feb. 12th, is an editorial on this subject. On pages 18 and 23, of Feb. 19th, there is a report and editorial respectively of the unearthing of an elaborate diamond smuggling scheme, the party arrested being ultimately convicted. On page 23, March 4th, is another editorial on the subject of the diamond tariff. Pages 16 and 23 of March 11th, contain respectively an account of and editorial on the decision of the United States Circuit Court of Appeals in the test case brought by Jos. Frankel's Sons, in reference to the tariff on diamonds. On page 19, Jan. 1st, 1896, is an editorial on this tariff. In the issue of Dec. 11, 1895, is an editorial in which we present figures that prove that a considerable amount of diamonds is smuggled over the border from Canada; the logic of this

editorial was so conclusive that the article was used with great force by the diamond importers in their endeavors to have the old diamond schedule returned. In the issue of Jan. 1, 1896, page 23, is published a letter from Congressman Quigg to President Nissen, of the New York Jewelers' Association, on the diamond tariff. On page 6, of March 18th, is a letter of President Nissen to David C. Townsend, of E. Aug. Neresheimer & Co., in which he reviews certain facts that he had obtained from official sources, and offers comments, based on experience and observation, upon the evils of the diamond tariff.

## Letters to the Editor.

### THE COLBY PENDANT SET DECISION.

NEW YORK, June 25, 1896.

Editor of THE JEWELER'S CIRCULAR:

We are somewhat surprised at the communication in THE CIRCULAR signed by the Dueber Watch Case Mfg. Co., inasmuch as every statement contained in it, with the exception of the remark as to "appellants" and "appellees," is erroneous.

1. The Colby decision unquestionably opens the manufacture of pendant setting cases, to all as we before stated.

2. The validity of the pendant setting movement patents has been confirmed by the courts of last resort, also as we stated, and any infringers will be prosecuted.

3. This patent matter had no relation whatever with the subject of the suits recently abandoned by the Dueber Co. in New York.

4. The proposition for the abandonment of these latter did not come in any way, directly or indirectly, from the defendants, but came directly from the plaintiffs—the Dueber Co.

Yours truly, ROBBINS & APPLETON.

### THE OHIO WATCHMAKERS' AND JEWELERS' ASSOCIATION

NEWPORT, Ky., June 24, 1896.

Editor of THE JEWELERS' CIRCULAR:

I take the first opportunity to inform you about the Ohio Watchmakers' and Jewelers' Convention, held at Piqua, O. After being five years out of office, I am again compelled to go into harness. Times are too hard and so the convention was not a boomer.

The officers elected are as follows: A. Thoma, president, Piqua, O.; H. Rohs, vice-president; Ed. G. Lohmeyer, secretary; F. Pieper, treasurer; board of directors, L. F. E. Hummel, H. H. Mithoefer, J. H. Lentz, Lewis Hohnack, J. J. Nurre.

Reports were acted upon, but nothing new was attempted.

The association has made Cincinnati its permanent headquarters, so the association has ceased being migratory.

The old "guard" as underlined above [A. Thoma, H. Rohs, E. G. Lohmeyer, F. Pieper, L. F. E. Hummel, H. H. Mithoefer, J. H. Lentz], will try hard to improve the association this coming year.

The board of directors are delegated to elect delegates to the national convention at Atlantic City.

Yours truly,  
ED. G. LOHMEYER, Sec.

### New York Notes.

A judgment against Horace Craighead as executor, for \$101.12, has been entered by F. E. Guy.

Josephine Noekin, 239 Eight Ave., has renewed a chattel mortgage on jewelry fixtures for \$1,000 to R. Muller.

The remaining jewelry stock of the late Constant F. Wadsworth, Peekskill, N. Y., was purchased by a firm in this city last week.

Rudolph C. Hahn, importer of precious stones, 65 Nassau St., has been elected a member of the New York Jewelers' Board of Trade.

The Holmes & Edwards Silver Co. have arranged with the Whiting Mfg. Co. to carry a full line of the latter company's sterling silver ware at their salesroom, 2 Maiden Lane, in connection with their own brand of sterling silver inlaid and silver plated flatware.

Israel Sternseher, 17 John St., gave a chattel mortgage for \$1,200 last week to I. Woolstein, refiner, 25 John St. Sternseher's shop was closed when a reporter called, but Mr. Woolstein, who holds the mortgage, said that matters would be adjusted and the shop running again within a few days.

The Whiting Mfg. Co., of New York city, have filed with the Secretary of State a certificate of an increase in their capital stock from \$300,000 to \$1,000,000. The company have a paid in capital of \$300,000, and their debts and liabilities amount to \$170,000.

Wm. B. Ball and Mrs. Harriet Ball, Norwich, Conn., and Wm. E. Hicks, Lowell, Mass., have completed a course in ocular refraction under the direction of R. H. Knowles, M. D. Dr. Knowles with his family are now located for the Summer at 72 Cookman Ave., Ocean Grove, N. J. Correspondence may be addressed him at 106 E. 23d St., New York.

The firm of Louis Weil & Co., importers of diamonds, 45 Maiden Lane have been dissolved, and Monroe Engelsman, one of the partners, has succeeded to and will continue the business under his own name. He will import and cut diamonds and precious stones. Louis Weil, of Amsterdam, Holland, will continue to represent the interests of this house in Europe.

Superintendent Hyde, of Tiffany & Co., in speaking of the rumor circulated last week to the effect that the firm were soon to move to 34th St., said he could not imagine how the rumor originated as it was without foundation. There was not the least truth in the report. The rumor of Tiffany & Co.'s removal, he said, had been a periodic one for the past 10 years.

While about to alight from a Lexington Ave. cable car, at 23d St., Thursday noon, Paulding Farnham, of Tiffany & Co., met with a strange and disagreeable accident. Mr. Farnham had stepped on the platform when the car suddenly came to a standstill, throwing him with several other passengers upon the floor. Mr. Farnham was badly cut about the face, legs and body, and though not serious his injuries have been painful.

A notable transaction of the past week was the sale of the R. A. Loveland stock of Pail-

lard non-magnetic watches to Albert C. Becken, Chicago. Mr. Becken has also purchased the patents covering this watch, and purposes to manufacture and put upon the market a very complete line of the same. We understand the business will be continued as a strictly wholesale house at the same place, 177 Broadway, with A. A. Abbott in charge as manager. Mr. Abbott has managed the business for Mr. Loveland the past 18 months and by fair dealing, careful attention to the interest of his customers, and clean cut business methods has enhanced the popularity of the Paillard watches, and won the confidence of the trade.

Jacob Samek, pawnbroker, has brought an action against Mordecai S. Kaufman, a former diamond dealer of John St., and property clerk John F. Harriot, which brings up the Gomez case again. Nearly four years ago Mrs. Minnie Gomez obtained on memorandum several thousand dollars' worth of diamonds, which she pawned. Kaufman had her arrested upon the charge of grand larceny. She was held in bail for trial in the General Sessions, and the police took the property from the pawnbrokers and turned it over to the property clerk. Kaufman, to secure his property, instituted replevin proceedings, and the sheriff took the property from the property clerk. The pawnbrokers moved in the Court of Common Pleas to be substituted as the defendant in the replevin action in the place of the property clerk, but the Court refused permission and Kaufman got the jewelry and diamonds. In this present suit Kaufman's attorneys have interposed the defense that he was the owner of the diamonds and that he never legally parted with the possession of them.

### Made Money by Divulging a Diamond Smuggling Scheme.

BOSTON, Mass., June 25.—Franz Werner, 50 years of age, was brought to Police Headquarters to-day and booked as a confidence man. He is from New York. Werner had an elaborate scheme to get money out of people who were willing to engage in the business of smuggling diamonds. He made his victims acquainted with the details of his scheme, offered to give them \$10,000 for every trip across the ocean, and took from them then \$50 as a guarantee of good faith.

### Safe-Crackers Work Under A Blaze of Light.

DETROIT, Mich., June 29.—E. H. & F. H. Tighe's jewelry store was burglarized last night of \$60 worth of goods and \$3,000 worth of microscopic orders. The safe was cracked, though it is under a cluster of incandescent lights. The police are censured for the crime.

Dwight B. Hills, manufacturer of lever clocks, Plainfield, Conn., has been receiving the congratulations of his friends upon his having passed the silver anniversary of his wedding. Mr. and Mrs. Hills celebrated their silver wedding June 22nd at their residence in Plainfield, and were the recipients of many beautiful mementos.

### Providence.

All communications for this column, addressed to P. O. Box 1093, Providence, will receive prompt attention.

J. J. Rollins has started in the enameling business at 19 Page St.

The employes of the Nicholson File Co. began their vacation on Saturday for two weeks.

Both members of Tuck & McAllister are on the road, Mr. Tuck in Maine and Mr. McAllister in Iowa.

Graham Bros. is the name of a new firm of manufacturers of electroplated white stone goods at 363 Eddy St.

A recently established concern for the manufacture of plated buttons, etc., is J. G. Kenyon & Co., 363 Eddy St.

Snow & Westcott have commenced removal from 19 Snow St. to the new Metcalf building, corner Richmond, Pine and Page Sts.

Charles C. Wientge, for many years designer for the Howard Sterling Co., has entered the firm of Lebkeucher & Co., Newark, N. J., manufacturers of silverware.

James G. Lynch has sold out his business at 19 Page St. to W. S. Luther & Co., who have given up their shop at 40 Potter St. and taken the shop formerly occupied by Mr. Lynch.

The Summer vacation of the employes of the Gorham Mfg. Co. began Friday. It has been customary for these works to shut down a week or two at this time of the year; this year they will remain closed for two weeks.

The Tilden-Thurber Co. will be located in their handsome new building at the corner of Westminster and Mathewson Sts. on July 6th. All of the fixtures in their old store are to be sold. This firm are having an immense clearance sale.

A representative of Garibaldi & Bruns, Charlotte, N. C., has been in town the past week making purchases. Other recent buyers were Mr. Arnstine, of Arnstine Bros. & Mier, Cleveland; Sol Cerf, of Sol Cerf & Co., Pittsburgh; and A. Kingsbacher, Pittsburgh, Pa.

### Death of Archibald D. Simmons.

PROVIDENCE, R. I., June 27—With the demise of Archibald D. Simmons, another pioneer of the jewelry business in this vicinity has joined the great majority after a useful life. He was born in this city in 1827. Early in life he decided what business he would pursue, and entered on his career with a determination that he would be second to none in his chosen profession. He was eminently successful in his ambition. For 33 years he had exclusive charge of the business of the firm of J. W. Richardson & Co., manufacturers of gold society emblems, and although the firm is to-day composed of younger men than the founders of the business. Mr. Simmons has been retained as manager through all the changes of more than three decades, his ability, discretion and integrity, which he prized more than life, being appreciated by all who became interested in the conduct of the firm. A widow, a daughter and two sons survive the deceased.



## Special Notices.

Rates 75c. per insertion for notices not exceeding 3 lines (25 words); additional words 2 cents each. If answers are to be forwarded, postage stamps must be enclosed. Two insertions, 15 per cent. off; three insertions, 20 per cent. off; four insertions or more, 25 per cent. off. Payable strictly in advance. Display cards on this page will be charged at \$2.00 per inch for first insertion, subject to same discount as above for subsequent insertions.

Under the heading of **Situations Wanted** on this page advertisements will be inserted for One Cent a Word each insertion, no discount. This offer refers to **Situations Wanted only**. Payable strictly in advance. If answers are to be forwarded, postage must be enclosed.

## Situations Wanted.

Notices under this heading **ONLY** are charged at one cent a word, payable strictly in advance. If answer are to be forwarded, postage must be enclosed.

**POSITION** as traveling salesman; experienced. Address K 42, care JEWELERS' CIRCULAR.

**POSITION AS WATCHMAKER**, 20 years' experience. Address D., care JEWELERS' CIRCULAR.

**YOUNG MAN** wants a situation as watch and clockmaker. Address M. A., care Dupré, 312 W. 27th St., New York City.

**POSITION** as traveling salesman for South and South-western states, in jewelry or kindred lines. Address G. D., care JEWELERS' CIRCULAR.

**POSITION** by young man to travel south and south west with his father, who has had 10 years' experience; expenses and small salary. Address M. K., care JEWELERS' CIRCULAR.

**POSITION WANTED**, by traveling salesman; 10 years on road for Maiden Lane house in Middle and Western states; A1 references; who wants my services? Hustler, care JEWELERS' CIRCULAR.

**POSITION** by young man 24 years of age, several years' experience in jewelry business; salesman and general repairer; open until Sept. 15th; sober and practical; best of references. Address W. B. W., care JEWELERS' CIRCULAR.

**FIRST-CLASS DIAMOND MOUNTER**, setter; also general manufacturing jeweler, wishes permanent position with reliable house; 20 years' experience; A1 reference. Address E. M., 2907 Baltimore Ave., Kansas City, Mo.

## Help Wanted

**WANTED**.—Two retail optical salesmen of good appearance, and capable of adjusting frames; references required. Address Accurate, care JEWELERS' CIRCULAR.

**WANTED**.—Experienced traveling salesman to handle best American line of spectacles through New York State and the East. Address Optics, care JEWELERS' CIRCULAR.

**IMPORTERS** of precious stones and pearls want experienced salesman to call on manufacturing jewelers in New York and Newark. Offers treated confidentially. Address T., care JEWELERS' CIRCULAR.

## Business Opportunities.

**SPLENDID OPPORTUNITY** for a good workman, Brooklyn, N. Y.; good location, work pays all expenses, rooms in rear of store for living, all for \$600, half its value. Address B. N. Y., care JEWELERS' CIRCULAR.

**A RARE CHANCE** of a lifetime to buy a large jewelry store in a manufacturing city of over 60,000 inhabitants in Massachusetts; a big opportunity for a live man to make money. Address S. A. M., care JEWELERS' CIRCULAR.

\$1,200 will buy my 6,800 lb. steel-lined safe, plate glass store fixtures and balance of my clocks and silverware; will sell watches and jewelry if wanted; best opening in Oklahoma for a live jeweler. Chas. E. Rose, El Reno, Oklahoma.

**FOR SALE** in Philadelphia, a desirable business in a fine locality; clean stock about \$8,000, which can be reduced if desired; walnut fixtures, fine regulator, safes, etc.; good run of work; established 12 years. Address O. E., care JEWELERS' CIRCULAR.

\$650.00 **SPOT CASH** buys fixtures, material and optical goods of leading jewelry and optical store; established 15 years; western New York; bench work \$1,500 per year; only optician; will sell any other part of stock if desired. Address J. O., care JEWELERS' CIRCULAR.

**MAKE DIAMONDS** of pure crystalized carbon, of large size. J. E. Rankin, of Elk Rapids, Mich., desires to associate with himself persons with capital who would like to invest in this manufacture, as he wishes to perfect his plan and obtain a patent; The best of references given and required. J. E. Rankin.

**FOR SALE**, in Spencer, Mass., midway between Springfield and Boston, an old established jewelry store with little competition; about 8,000 inhabitants, in a pleasant manufacturing town; good stock, fine regulator, worth \$300; steel lined large safe, etc.; stock and fixtures inventoried last March at \$5,800; rent of store, \$200 per year; lighted with gas, and has running water; store can be bought for sixty cents on the dollar, for cash or good security; a good chance for a young man. Address E. F. Sibley, Spencer, Mass.

## For Sale.

**FOR SALE**.—A Marvin fire-proof safe; outside width 54 inches, height 65 inches, depth 28 inches. R. A. Loveland, 177 Broadway, N. Y.

**FOR SALE, CHEAP**, two wall cases, each 25 feet long, 18 inches deep, 9 feet high; solid walnut, slide up doors, closets below, moveable shelves; cost \$1,000, sell for \$275. R. C. Green & Son, Pottsville, Pa.

### FIXTURES FOR SALE.

Tilden-Thurber Co., Jewelers and Silversmiths, Providence, R. I., offer their present Store Fixtures for sale, consisting of Wall Cases of various lengths, Counters and Show Cases 10 feet long (some are fitted with Fletcher system), 1 Watch Case eight feet long (fitted with the Fletcher system), with trays and base for same. Gas and Electric Light Fixtures, Tables and various furnishings. All the above fixtures are of black walnut and the best make, and will be sold low for immediate removal.

## NOTICE OF DISSOLUTION.

Notice is hereby given that the copartnership heretofore existing and carried on under the firm name and style of Louis Weil & Co., has this day been dissolved by mutual consent.

Mr. Louis Weil will liquidate the affairs of the said copartnership through Mr. Monroe Engelsman who has been duly appointed his authorized agent therefor, at his office, 45 Maiden Lane, in the City of New York.

Signed } LOUIS WEIL.  
          } MONROE ENGELSMAN.

Dated July 1st, 1896.

## FOR RENT.

Large Office, 5th Floor - - **Corbin Building.**

Will let very low for  
Three Years.

APPLY, - - - -

**JOSEPH FAHYS & CO.,**

NO. 54 MAIDEN LANE, N. Y.

## A. C. Wrede Chattel Mortgages His Stock.

HOUSTON, Tex., June 25.—In the county clerk's office Tuesday afternoon A. C. Wrede, doing a jewelry business at 409 Travis St., filed a chattel mortgage, transferring his stock to J. P. Rotge, as trustee for the benefit of the following creditors:

Ira P. Jones, \$50; Houston Jewelry Co., \$36.94; Houston Post, \$10.96; Gas company, \$3.90; Leonard Krower & Co., \$820.99; Waterbury Watch Co., \$39; F. J. Bersse, New York, \$200; Henry Froehlich & Co., \$172.46; Z. Oppenheimer, \$143.31; E. A. Cowan & Co., \$494.90; Hayden W. Wheeler & Co., \$78; Skillman, Vanderveer & Williams, \$23.50; Rogers & Bro., \$188.97; S. Valfer & Co., \$37.50; Elliott W. Longley, \$176.60; H. Z. & H. Oppenheimer, \$15; P. Grusberg, New York, \$58; Max Frennd & Co., \$20; L. H. Keller & Co., \$199.51; Fred Kaufman, \$40.97; E. S. Johnson & Co., \$16.

## The Jury Decides Marcus Marks Did Not Steal Becker & Lathrop's Diamonds.

SYRACUSE, N. Y., June 24.—Marcus Marks is not guilty of the theft of Becker & Lathrop's diamonds. That was the agreement of the jury, reached at 6:10 o'clock this morning, and reported to the court two hours latter. There were only the officers in charge of the jury present when the knock came, and a voice said that agreement had been reached.

This afternoon Deputy Sheriff Reese of Utica came after Marks and took him to Pent-Up. Marks went along very willingly.

The schedule of liabilities of Geo. H. Kettmann & Co., Louisville, Ky., the jewelers who assigned some time ago, was filed June 22, and shows the amount of same to be \$15,829.62.

Stephen Messerer, jeweler, 15 Springfield ave., Newark, N. J., informed the police last Monday that his living apartments over his store had been entered by a thief the night before who carried off diamonds, jewelry and trinkets to the value of about \$200. The family was absent at the time and the apartments were entered by means of a skeleton key.

## FOR SALE.

Two Fine Black Walnut Wall Cases, twelve feet long. Two twenty-four feet long. One twenty-five feet long.

These cases have vertical sliding doors, and were made by B. & W. B. Smith, and are in perfect condition.

**REED & BARTON,**

37 Union Square, New York.

SEND FOR CATALOGUE of books for the jewelry and kindred trades. Just issued. JEWELERS' CIRCULAR PUB. Co., 189 B'way, N. Y.

# Our Traveling Representatives



Traveling representatives may consider these columns open for the publication of any news or items of interest regarding themselves or their conferees.

**GEO. B. MILLER**, who has been connected with Wallace & Sons for 27 years, will hereafter represent the Bridgeport Brass Co., with headquarters in Bridgeport, Conn.

Hustling after orders in Syracuse, N. Y., the past week in spite of the warm weather, were noticed: H. C. Bliss, Bliss Bros.; T. C. Nicholson, Flint, Blood & Co.; Chas. E. Bride; H. D. Mix, Wightman & Hough Co.; A. Kingsland, Reeves & Sillocks; Mr. North, Smith & North; V. L. Burgesser, Krenmentz & Co.; J. Goldberg; W. T. Mason, H. Wexel & Co.

Traveling men visiting the Hub the past week included: John L. Shepherd, Keystone Watch Case Co.; H. E. Slater, Champenois & Co.; Horace D. Sherrill, Sinnock & Sherrill, Charles Roe, E. Ingraham Co.; Mr. Moulds, New Haven Clock Co.; Charles Power, Ludeke & Power; Herman A. Friese and John A. Abel, Lewis, Kaiser & Luthy; F. C. Allen, for A. Wittnauer; Fred Clarkson, Snow & Westcott.

Traveling men in New Haven, Conn., last week were: Mr. Griscom, Bippart & Co.; Mr. Clarkson, Snow & Westcott; Mr. Carrow, Mandeville, Carrow & Crane; Frank Wood, Carter, Hastings & Howe; Mr. Carter, Sloan & Co.; representatives of Silver City Plating Co.; David Harris; Mr. Bleecker, Bassett Jewelry Co.; Dick Everitt, Daggett & Robbins; Mr. Hall, Wilcox Silver Plate Co.; Mr. Meyer, Simpson, Hall, Miller & Co.; Mr. Schwab, H. Z. & H. Oppenheimer.

The following traveling salesmen passed through Detroit last week: Mr. Foster, Unger Brothers; D. I. Byers, the Cincinnati Gold & Silver Refining Co.; J. R. Goodwin, Carter, Hastings & Howe; H. B. Bliss, Gorham Mfg. Co.; E. W. McAllister, Irons & Russell; Mr. Fonteneau, F. Fonteneau & Co.; C. C. Offerman, William Smith & Co.; Charles B. Bartlett, Whiting Mfg. Co.; James H. Donnelly, Alvin Mfg. Co.; A. Kingsland, Reeves & Sillocks; George W. Bleecker, Bassett Jewelry Co.; Clarence Pettit, Hayden Mfg. Co.

Travelers in Pittsburgh, Pa., last week were: Edwin L. Mumford, Waite, Thresher Co.; E. I. Rogers, Parks Bros. & Rogers; Harry Scofield, Lincoln, Bacon & Co.; J. G. Fuller, J. G. Fuller & Co.; W. W. Middlebrook, B. A. Ballou & Co.; A. A. Greene, A. A. Greene Co.; H. B. Kennion, H. D. Merritt & Co.; A. J. Sherrard, Enos Richardson & Co.; J. A. Granbery, Cutler & Granbery; Sol Caro, for James Bergman; Mr. Whiting, S. E. Fisher & Co.; C. F. Willemin, T. G. Frothingham & Co.; H. D. Mix, Wightman & Hough Co.

## The Latest Patents.

ISSUE OF JUNE 23, 1896.

**562,415** CYCLOMETER. URIAH E. PENNY, Chicago, Ill., assignor of one-half to Harris Haas, same place. Filed July 11, 1895. Serial No. 555,633. (No model.)

**562,424**. INSTRUMENT FOR USE BY OCULISTS AND OPTICIANS. FREDERIC G. RITCHIE, New York, N. Y.—Filed April 12, 1895. Serial No. 545,443. (No model.)

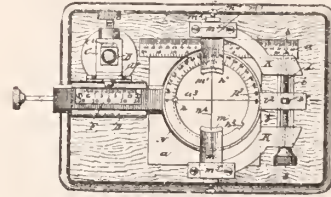

An instrument of the character described, constructed with a revolving cell adapted to hold or support a lens or prism, and having a scale thereon, and a bed or base below said cell, and having a scale and line thereon.

**562,430**. ADVERTISING CLOCK. CAMILLO SPAVENTA, New York, N. Y.—Filed June 28, 1895. Serial No. 554,389. (No model.)

**565,516**. WATCH MOVEMENT HOLDER. CHARLES M. EVANS, Reading, Pa.—Filed Jan. 29, 1896. Serial No. 577,294. (No model.)

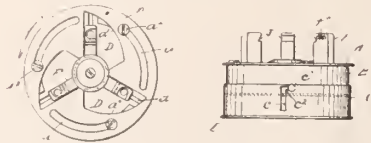

In a movement holder and escapement-deptening tool, the movement holder jaws, sliding in one guide plate and operated collectively by an operating plate E, in combination with a locking plate A, for locking said jaws.

**562,539**. CLOCK-WINDING MECHANISM. WILHELM JEEGER, Niedereschach, Germany. Filed Dec. 3, 1895. Serial No. 570,915. (No model.) Patented in France Sept. 7, 1893, No. 232,681; in Germany Dec. 7, 1893, No. 77,766; in Austria-Hungary Mar. 14, 1894, No. 51,451 and No. 81,300, and in England July 10, 1894, No. 13,360

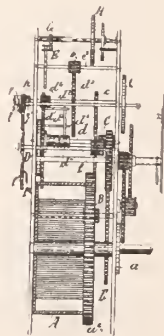

The combination in a clock-movement provided with a mainspring, of an equalizing-spring, the shaft of which is connected with the shaft of the mainspring, and the shaft of the escapement-wheel, by separate systems of intermediate gearing, the system connecting with the escapement-wheel, embracing the wheel *f1*, having pins *f2* and *f3*, as described, and the cylinders *gg1*, adapted to be engaged by the pins *f2* and *f3*.

**562,656**. INSIGNIA AND CAMPAIGN BUTTON. AUGUSTUS PHELPS, Newark, N. J. Filed

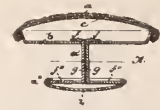

Jan. 3, 1896. Serial No. 574,191. (No model.)  
**562,729**. SPECTACLE FRAME. REYNOLD J. KIRKLAND, Grand Rapids, Mich. Filed Apr. 25, 1895. Serial No. 547,156. (No model.)



In spectacles having bows adapted to attach the same to the head, the combination with the lens-frame, of the flexible strips connecting the bows and lens-frame, and means for bending and retaining said flexible strips with relation to the bows.

**562,730**. THIMBLE. URIAH A. KNAUSS, Bethlehem, Pa., assignor of two-thirds to William H. Jacobs and John B. Mciwell, South Bethlehem, Pa.—Filed March 5, 1896. Serial No. 581,963. (No model.)



A thimble provided with an exteriorly-arranged needle-grasping clamp movable by pressure thereon toward the wall of the thimble.

DESIGN **25,655**. BUTTON. WASHINGTON W. PIERCE,



Huntsville, Ala.—Filed May 2, 1896. Serial No. 590,030. Term of patent, 7 years.

DESIGN **25,656**. BUTTON BADGE. COLLIN C.



Groones, Brookland, D. C.—Filed May 18, 1896. Serial No. 592,064. Term of patent 3 1/2 years.

DESIGN **25,657**. BADGE. JAMES L. SIBLEY, Ma-

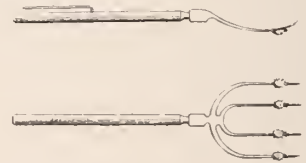

rietta, Ga.—Filed May 20, 1896. Serial No. 592,366. Term of patent 3 1/2 years.

M. H. Livingston has been appointed temporary receiver of the R. Michaels jewelry establishment, 925 Main St., Kansas City, Mo., on motion of the National Bank of Commerce, which is one of the principal creditors of the concern. The appointment was made by Judge Dobson, and Livingston furnished bonds for \$10,000. Emil Pollak, the trustee in whose hands the stock and fixtures were placed on the day of the failure, gave way to Mr. Livingston at once.

### Skiascopy and Ophthalmoscopy.

At the recent convention in Syracuse, N. Y., of the Optical Society of the State of New York, L. L. Ferguson, refractionist and instructor of optics with the Julius King Optical Co., New York, made an address on "Skiascopy and Ophthalmoscopy" as follows:

The skiascope and ophthalmoscope are two instruments which to the optician are absolutely indispensable, and the knowledge of their proper uses cannot be too widely disseminated among those who should or are supposed to use them.

First in importance is the ophthalmoscope, for the very patent reason that at one glance it enables the capable optician to determine the normal from the abnormal, to determine the presence of pathological conditions of either the retina, choroid or optic nerve.

In projecting these slides it is not my intention to convey to you the idea that you must be able to differentiate between these pathological conditions so that you will be able to diagnose and inform your clients as to just what the matter is, for frankly it is none of your business; yoursphere of action ceases the moment you have discovered anything which would convey to you the suspicion that medication was necessary.

Now, unfortunately, there are too few that understand how to use the ophthalmoscope, and more than opticians are included in that category.

The mere act of placing an ophthalmoscope up to your client's eye, and peering through it without the knowledge of how to intelligently rotate into position the proper lenses is humbug pure and simple! For upon your ability to relax your accommodation and to differentiate between the linear distances from the macula and the optic papilla to the crystalline lens, depends your ability to diagnose between the normal and the abnormal.

You must remember that 1.00 dioptre is equivalent to 1-3 of a M. M. as regards retrocession or protrusion of the optic nerve in optic atrophy, glaucoma and papillitis respectively, and that to correctly observe such conditions it is essential that your accommodation should be held in complete abeyance and your client's as much as possible by having your office rather dark and directing him to fix vision on some particular object in the distance.

You know that the emmetropic eye is adapted for parallel rays of light and as such the emergent rays travel in the same direction, i. e., parallel.

Now if the ophthalmoscopist can inspect the retina of his client's eye with his accommodation entirely relaxed, the light which is deflected by the mirror into the observed eye will again be reflected by the retina and emerge parallel, enter the observer's eye and without effort be brought to a point on the retina.

Now if the observed eye be hypermetropic the emergent rays will be divergent and as such it neutralizes the convexity of the dioptric media of the observer's eye, and to restore the equation it necessitates the rotation of a convex lens into position.

In a myopic eye the emergent rays are convergent and as such it is treated by the interposition of a concave lens, whose angle of divergence equals the angle of convergence of the emitted rays.

The indirect method is probably the best for a general ensemble of the eye, for while the magnification is only 4 or 5 times it gives a greater field of vision than the direct method, which gives magnification of about 18 times.

So then use the indirect method, and if anything particularly attracts your attention, proceed to use the direct method, which, with its

attendant higher power, gives you a larger image of what you desire to see.

Frequently persons will be found where the pigmentation of the choroid is so intense that nearly all the rays of light deflected by the mirror upon the retina is absorbed, consequently the illumination is so poor with the direct method that it is best to resort to the indirect, which by its smaller magnification and the larger amount of rays bent thereby into the eye gives a greater volume of vergent rays.

To summarize matters first use the indirect method to determine the presence of diseases of the retina or choroid, then with the direct method determine the refraction of the eye at the macula, and then at the optic nerve.

This done you have completed your search for pathological disturbances in the posterior portion of the eye, and incidentally secured an approximate judgment as to the amount of ametropia which you must afterward confirm by using your skiascope.

There are about twenty specific diseases that should be detected with the ophthalmoscope; most assuredly out of this number there are many that present various phases, but a large percentage are rare, and it may not be your lot to see them all in a decade.

Cataracts are fairly common; there are about eight varieties, and it requires but a modicum of skill to diagnose them. Simply rotate a strong ex. lens, say a plus 11.00 D to the aperture of the ophthalmoscope, deflect the light into the pupil, and first examine the central field, and then the periphery by directing your client's gaze upwards, downwards, inwards and outwards, while you illuminate the lens obliquely to see if there is an incipient cataract.

For detecting opacities of the anterior chamber and cornea oblique illumination a convex lens of about two inches focal length is the best. Accomplish this by focalizing the rays from an artificial luminous source laterally upon the spot you wish to examine.

Opaque bodies of course will interrupt the transition of light and will appear darker in ratio to their opaqueness.

Now then you have thoroughly inspected your client's eyes and finding nothing that would deter you as a conscientious optician from exercising your inalienable right to adapt the necessary glasses, you may proceed with whatever method you may choose, either subjective or objective.

Skiascopy is the simplest form of objective methods and as such cannot be too well understood and too often used by opticians generally. I shall not enter into an analysis of the method as it has been ably demonstrated by our fellow member, Mr. Cross, but confine myself to a bare exposition of its cardinal principles. Mirrors of two kinds may be used. The plane is to be preferred, as it admits of any distance between the observer and observed, save the regulation 1. meter.

The emitted rays from a hypermetropic eye are divergent from the moment they leave the cornea; therefore with the plane mirror the reflex rays or penumbra move in the same direction as the mirror. So much for diagnosing the ametropia. Now to correct simply impose the strongest convex lens that does not reverse the penumbra—myopia—the reverse, emitted rays are convergent—therefore the penumbra moves in the contrary direction to the movement of the mirror—to correct impose the strongest concave lens that does not reverse the penumbra.

Recollect that in skiascopy you are dealing only with a quadrant of the dioptric media at a time; finish up the first meridian with ophericals, then measure the meridian at R. A. and if just the same amount of penumbral movement is observed in the already corrected meridian, you have while correcting one angle unconsciously all; therefore the eye is either hypermetropic or myopic equally in all

meridians and requires merely a spherical lens to correct.

But if when one meridian is corrected and you direct your attention to the meridian at R. A. and find the penumbra is more plainly visible, moving either with or against according to the nature of the ametropia, interpose a cylinder either plus or minus and let the axis be coincident with the position of the band of light which is a phenomenon more or less conspicuous in all forms of regular stigmata.

Irregular astigma is indicated by the fundus reflex being of uneven intensity, assuming the appearance of being mottled, due to the different angles or indices of refraction of the cornea; the adaptation of cylindrical lenses to such conditions at its best is unsatisfactory, but if prescribed the weakest possible cylinder that gives fair results will be the best. The asymmetry of the cornea in such cases precludes it absolute correction by a lens of equivalent refraction, as it is impossible to grind a cylindrical lens that has *practically* more than one axis.

Irregular mixed astigma is not infrequent, the phenomenon of which is the simultaneous subdivision of the emitted light, one-half traveling in the same direction as the mirror, the other half at the opposite end of the same meridian, moving against the mirror. This form is probably congenital, and is not due to cicatricial formations caused by corneal ulcers, etc., which is, as a rule, the etiology of the more mottled phenomena.

In such cases, the safest procedure is to get the best vision attainable, by spherical lenses, and not to attempt to correct the cornea which may have half a dozen indices of refraction, by imposing thereon a cylinder which has practically but one. Conical cornea is more quickly diagnosed by Skiascopy than by other methods. The appearance sequent thereto is the brilliant illumination of the whole fundus, save a portion which assumes the shape of a cone, the apex of which designates the locality of greatest projection.

### Fox & Stendicke,

Manufacturing Opticians,

61 Fulton St., New York.

Javal, Schiötz Ophthalmometers, Phorometers, Skiascopic Apparatus, etc., etc.

Send for Price List.

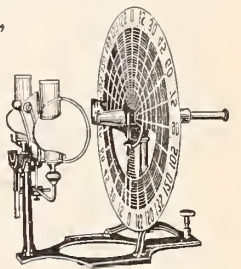

WE HAVE ON HAND

A Large Number of Small

### Advertising Cuts

Specially Designed for JEWELERS' ADVERTISING, such as above, at 75 Cents per Electrotype.

SEND FOR PROOF SHEET.

THE JEWELERS' CIRCULAR PUB. CO., 189 Broadway, New York.

THE STAR OF EMPIRE WESTWARD TAKES ITS WAY

# WESTERN SUPPLEMENT

## of THE JEWELERS' CIRCULAR

VOL. XXXII.

CHICAGO, WEDNESDAY, JULY 1, 1896.

NO. 22.

### Chicago Notes.

*All communications in reference to the Chicago department of The Jewelers' Circular, addressed to S. Parlin, 270 Garfield Ave., Chicago, will receive immediate attention.*

Mr. Bidwell, of Bidwell & Tappert, Monticello, Ia., has been making purchases for his firm.

Numerous June weddings have been productive of increased orders to sterling silver houses.

Mr. Loeb, Wabsworth Watch Case Co., returned Monday from a general trip and a visit east.

Ralph E. Lovewell makes his debut in the jewelry trade as an assistant to George E. Marshall & Co.

J. W. Hamilton, Danville, Ill., a prominent man in the business, was among the buyers of the week.

Manager Weidig, Jos. Fahys & Co., is in New York on business matters for two or three weeks.

J. G. Lewis and wife, Dwight, Ill., passed through Chicago to spend the Summer at Lake Minnetonka, Mich.

H. S. Noyes, manager for Bates & Bacon, has gone to the factory and New York, to be absent two to three weeks.

E. A. Dorrance, manager for Simons, Bro. & Co., returned Saturday from the east and spent Sunday at his Summer cottage in Antioch, Ill.

American Horological Society, of Chicago, Ill., without capital stock, have incorporated; Incorporators, Oscar Hartung, J. H. Purdy and C. H. Hazlitt.

B. F. Simpson, of Otto Young & Co., who has been traveling in the northwest, says prospects there are very good. Crops are in good shape, and dealers are confident of a trade above the average of recent years on the advent of Fall business.

Mr. and Mrs. J. G. Lietsch, Mount Union, Ia.; W. H. Steever, Henry, Ill.; M. L. Larson, Batavia, Ill.; Wm. L. Winslow, Ironwood, Mich.; A. I. Chamberlain, Foster, Ia., and Arthur Rovelstad, Elgin, Ill., looked over the market the past week and made purchases.

"We have had more orders the past week than for the balance of the entire month preceding it," said W. H. Vogell, of Alfred H. Smith & Co. "It was a general business, with orders from all parts of the country, and shows to us that there is a better feeling in trade circles."

James H. Donnelly, in charge of the Alvin

Mfg. Co.'s Chicago office, 5th floor Columbus Building just returned from a Michigan trip, reports a greater confidence among dealers in that section than existed earlier in the season and it was thought the completion of the nominations of National conventions would greatly aid in restoring a stronger feeling of confidence.

O. W. Wallis reports an almost clean sheet of acceptances of his recent offer. The incorporation of the new company has been effected. Mr. Wallis will be the active manager, and the company have received much encouragement and many offers of assistance in their new enterprise. The ordinary working expenses have been reduced to a minimum and the business is being conducted on the safest of principles.

Harry Pierce, who attempted to steal a tray of jewelry from the jewelry store of F. D. Brown, 739 Lincoln Ave., last week, was held in the criminal court. C. Ternandt, a jeweler, 401 Larabee St., identified Pierce as the man who stole a watch from him a short time ago. Pierce's method was to make a purchase, have it wrapped up, and then run away with it before paying. It is understood he has also victimized jewelers by taking a tray to the front of the store "for a better light" and when near the door make a dash for the street and escape.

Frank Schultz, wanted on the charge of larceny, was arrested last week. Schultz had been employed in the jewelry store of F. R. Cross, 310 92d St., for several months, and had always carried a key to the place. On last Saturday night 19 watches and 22 gold rings were taken from the stock. When Schultz was searched at the police station four watches and two rings, which were later identified by Mr. Cross as his property, were found. The prisoner finally admitted selling seven watches and eight rings to Night Clerk Howard of the Alhambra Hotel, for \$3. The property was found in Howard's room.

### Detroit.

Fred Grimm, Mt. Clemens, Mich., purchased goods here last week.

Fred Gillam, formerly with D. D. Shane, Grand Ledge, Mich., has opened a jewelry store in that place.

Fred A. Drexel, wholesale jeweler here, was last week united in marriage to Miss Sarah K. Hotchkiss, of Waterbury, Conn.

West Cook, representing E. G. Webster & Son New York, has closed up the Detroit office for the Summer and is in New York.

### St. Louis.

Edwin Massa is on a trip to Ohio.

B. F. Hodgins has resigned his position with M. Eisenstadt Jewelry Co. and has left for New York.

Gerhard Eckhard, 308 N. 6th St., is putting in a handsome new front, and making many other improvements that will greatly enhance the beauty of his store.

Owing to the convention of the National Retail Jewelers' Association, the board meeting of the Missouri Retail Jewelers' Association will be held July 1st, and the annual meeting of the same organization July 8.

Herman Manch, president of the National Retail Jewelers' Association, was honored by Damon Lodge No. 29 K. of P. last week, by being elected as a representative to the Grand Lodge K. of P., which meets at Sedalia, Mo., in October.

The original "topaz diamond" establishment has shut up shop. This place opened business about two months since, and charged \$1.00 each for the stones. Before they closed out last week the price had fallen to 5 cents each for the "gems."

A man calling himself Mr. Stone, was introduced to N. Roitman, jeweler, 802 Franklin Ave., by a Mrs. Kauffman, who was known to the jeweler. He purchased a gold watch and chain valued at \$78.80, which he claimed was going to be presented to a member of Robt. E. Cowan Lodge, No. 131, Knights of Pythias. Pursuant to instructions of Stone, Roitman took the jewelry to the ante-room of the lodge, Monday evening, Jan 22. There he met Mr. Stone and gave him the watch and chain, as he stated he wanted to show it the members. When Mr. Stone returned from the lodge room he gave Roitman a check signed "Henry F. Taylor, Chancellor Commander." Subsequently Roitman learned the check was worthless, as the lodge had nothing to do with buying the watch and chain, and Mrs. Kauffman knows nothing about Stone, who has decamped.

John Hoffman, jewelry peddler, Dunmore, Pa., was arrested last week on the charge of obtaining goods under false pretenses. The allegation is that he took home a bill of goods amounting to \$17.20 from the store of A. T. McWilliams, 120 Penn Ave., agreeing to pay for them if on examination they met with his approval. Now it is said he refuses to return the goods or pay for them.

**Pacific Coast Notes.**

Y. H. Boudreau, of Modesto, Cal., has removed his jewelry store to 10th St.

George Lamax has opened a jewelry shop in Crane & Virdens' drug store, Ventura, Cal.

Emil Henschober, Port Townsend, Wash., has been in San Francisco on a business trip.

Leon Carrau, of Carrau & Green, San Francisco, is in the northwest on an extended business trip.

S. E. Lucas & Son, retail jewelers, Los Angeles, Cal., have filed a petition of insolvency. Liabilities, \$2,668.48; assets, \$167.50.

C. Hadenfelt, of Rothschild & Hadenfelt, San Francisco, has returned from an extended business trip through Colorado, New Mexico and adjoining States.

D. Jones' store, Santa Cruz, Cal., was burglarized one night recently, three trays of jewelry being taken.

Max Kuner, watchmaker, Los Angeles, Cal., has removed to 215 S. Spring St., in the Holtenbeck Hotel block.

Cyrus Fred Douglass, a jeweler, Lompoc, Cal., has obtained a divorce from his wife on the ground of unfaithfulness.

San Francisco jewelers have not as yet begun handling bicycles to any extent, with the exception of Lundy, of the "Emporium."

E. S. Barton, of Reed & Barton, Taunton, Mass., who has been visiting in the City of Mexico, has returned to the United States.

A. J. Bailey & Bro. will enlarge their watch and jewelry establishment by adding the office vacated by F. E. Trask, in Ontario, Cal.

Edward Rudolph, a San Francisco jeweler, 55 years old, committed suicide on the night of June 14th. Long continued illness was the cause.

A petition of voluntary insolvency has been filed by A. E. Lutnezky, Santa Maris, Cal. The schedule of liabilities shows debts to the amount of \$1,130.48, the largest amount, \$566.56, being owed to S. B. Dinkelspiel & Co., San Francisco. The value of all the assets of the insolvent is given as \$550.68.

On Saturday night, June 6th, fire broke out in the show window of F. H. Conant's jewelry store, 728 State St., Santa Barbara, Cal. Mr. Conant dropped a lighted match to the floor of the window, which was covered with several layers of tissue paper. The flames were smothered out before the fire department arrived, but considerable damage was done by the smoke and his loss will amount to several hundred dollars.

**Indianapolis.**

Louis Burgheim has opened a new jewelry store on Virginia Ave.

Carl F. Walk will spend his vacation camping in northern Wisconsin.

Baldwin, Miller & Co. have made their salesroom very cool and attractive looking with a number of palms and foliage plants.

Traveling men in Indianapolis, last week included Mr. Keene, Ostby & Barton Co.; M. E. O'Donald, Courvoisier-Wilcox Mfg. Co.; Jack Fuller, J. G. Fuller & Co.; C. F. Willemin, T. G. Frothingham & Co.; Mr. Wilson, Crescent Watch Case Co.; H. E. Osborn, Osborn & Co.; Mr. Bliss, Gorham Mfg. Co.; Fred. Foster, Unger Bros.; and a representative of J. W. Richardson & Co.

Two men have been going about the northern part of Indiana representing themselves to be employes of the State Board of Health. They visit a house, state that the board of health has just issued an order requiring all persons to be examined for defective eyesight, and that they have been retained to fit the glasses. They have thus been able to sell many pairs of cheap spectacles at fancy prices to persons possessed of perfect eye-sight.

July 4th has brought some badgework to the manufacturing jewelers. Craft & Koehler have secured the order for four handsome gold badges as well as a number of diamond studs and rings to be given as prizes by the Indiana Cycle Track Co. Geo. G. Dyer is working on 12 gold and silver badges for the Fort Wayne bicycle meet, July 4th. He has also furnished a very fine gold badge set with diamonds for the retiring State G. A. R. Commander, and a beautiful \$100 gold badge to be contested for at the July meet of the Limited Gun Club.

J. R. Hendricks was arrested a few days ago at a jewelry store on Edmond St., St. Joseph, Mo., on the charge of being a fugitive from Tennessee. The arrest was made at the instigation of A. G. Wilson, city marshal of Brookfield, and it alleged that Hendricks robbed a jeweler, W. P. Richards, at Union City, Tenn., on the night of May 9th, of a set of jeweler's tools, valued at \$100.

**AUSTRALIAN OPALS**

IN THE ROUGH. TRADE ONLY

ARTHUR F. CATE,  
1125 WALNUT ST., - - DES MOINES, IOWA, U. S. A.

**THE PERFECTION SHOW CASE**

FOR FINE JEWELRY TRADE.

WE CHALLENGE THE WORLD TO PRODUCE ITS EQUAL.

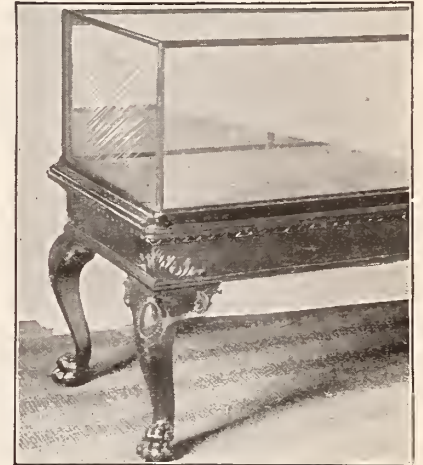

IF YOU ARE INTERESTED IN SHOW CASES AND JEWELRY FURNITURE, WRITE US FOR FULL INFORMATION.

**A. H. REVELL & CO.,**

431 to 437 Fifth Avenue, Chicago.

**ELGIN KING**  
100.00 Bicycles

Are as perfect as the very best material and mechanical genius can make them.

Write for Catalogue and Agents' Terms.  
Send 10 cts. for Elgin King Scarf Pin.

Address Dept. A,  
**ELGIN CYCLE CO.,**  
ELGIN, ILL.

**TOWLE MANUFACTURING COMPANY,**

\*\*\* SILVERSMITHS \*\*\*

COLONIAL.

NEWBURYPORT, MASS.



COFFEE SPOON.

149-153  
STATE ST.,  
CHICAGO.

**PARSONS & SCHOOL**  
—FOR—  
**WATCHMAKERS,**  
PEORIA, ILL.  
Send for Circular and Terms.  
**PARSONS & CO.**

### Cincinnati.

W. Wise, of Bloom & Phillips, has left for a trip south.

M. Brooks, of Brooks & Dole, Madison, Ind., was in Cincinnati last week buying goods.

Jos. Sauer has removed from 934 Monmouth St., Newport, Ky., to 908 Vine St., Cincinnati.

Jos. Noterman, Jr., has been appointed administrator of the estate of his late father-in-law, George Mabus, who died last week.

Eugene Frohmyer has left for Put-in-Bay for a vacation, Gus Frank for French Lick Springs, and A. Herman is at Mt. Clemens.

Two female diamond thieves were caught in St. Louis last week, Dora Donegan and Jennie Monroe, and the capture is considered the best made this season. Both are known in Cincinnati.

The Bell Watch Case Co. have established an agency in San Francisco, with Simon Caro as manager. He will also represent the O. E. Bell Co. in jewelry and leather goods, and the Cincinnati Silver Co.

Oskamp, Nolting & Co. have given a handsome silver trowel to the Emanuel Baptist Church on Freeman Ave., now in course of construction. The trowel will be sold at the dedication to the highest bidder. It is valued at \$100.

The Cincinnati Wholesale Jewelers' Association attended the funeral of Jos. Gosling, of Jos. Noterman & Co., in a body, and several of the members were the pall-bearers. The funeral was largely attended by friends from surrounding towns.

The Gustave Fox Co. are very handsomely established in the upper rooms at 4 W. 4th St. This firm are the makers of the standard Elk goods, which are patented and for which they have gained a reputation throughout the United States. The meeting of the Elks in July has kept them busy on emblems for the occasion.

The event of the past week was the opening of Frank Herschede's new store on 4th St. It is voted the handsomest store in town. The furniture and fixings are of mahogany of the most artistic designs. The two floors were decorated with flowers and pot plants in profusion, which lent beauty to the occasion. A special feature of the exhibit was the magnificent display of table silver loaned by the leading makers of this country, which attracted much attention. The spacious rooms were crowded with an appreciative assembly on both opening days.

### News Gleanings.

Correll & Co., Concord, N. C., has assigned. Horace Shepard, Bronson, Mich., has sold out.

Chas. E. Van Voorhees, Monett, Mo., has assigned.

J. E. Colony, Bangor, Me., has assigned to B. C. Addison.

J. D. Walker has removed from Cuero, Tex., to Yoakum, Tex.

T. H. French, Hopedale, Mass., is closing out his business.

S. S. Powell has opened a new jewelry store in Hailey, Idaho.

Bennett & Guyselman, Urbana, O., will dissolve partnership.

Joseph Clay, Atlanta, Ga., has given a chattel mortgage for \$400.

Daniel C. Fischel, Troy, N. Y., has removed to Green Island.

L. W. Hensell, Shohomish, Wash., has removed to Seattle, Wash.

G. B. Richardson has sold out his jewelry store in Martinsburg, Ia.

W. H. Hooper has disposed of his jewelry business in Moscow, Idaho.

A. F. Jahnke, Richmond, Va., is advertising his stock for sale at auction.

Simon Eyerman will soon quit the jewelry business in Kansas City, Mo.

Windle & Bolster, Fall River, Mass., have renewed their mortgage for \$800.

Alston & Maxwell, Tuscaloosa, Ala., have given a realty mortgage for \$5,000.

The death is reported of J. H. Wuerth, of J. H. Wuerth & Son, Leavenworth, Kan.

A. Hauerbach, Salt Lake City, Utah, has lately disposed of some mining interests.

Williams Bros. have succeeded to the jewelry business of J. W. Williams, King City, Mo.

Thayer & Adams, Belfast, Me., have dissolved. Mr. Adams will continue the business.

Fred Jensen has given a chattel mortgage on his jewelry business in West Bend, Ia., for \$260.

Richard Krumpf has discontinued the jewelry store he has been operating in Portland, Ore.

J. H. Leyson, Butte, Mon., has returned home from an extended visit to his old home in New England.

H. C. Kachlein, Lafayette, Ind., is in Chicago, where he is examining plans for his new apartment house.

E. C. Putnam, West Boylston and Milbury, Mass., has mortgaged his stock and fixtures at Milbury, for \$700.

Carlson Bros., Bellewood, Pa., are disposing of their stock at auction. They expect to leave for Sweden in a few days.

H. B. Johnson has removed from Ocean Grove, N. J., to the corner of Cookman Ave. and Bond St., Asbury Park, N. J.

The deputy sheriff last week sold out G. L. Ackerman's jewelry store, Wyoming Ave., Scranton, Pa., on a judgment of \$1,136.67. The sale brought \$118, the purchaser being William M. Ackerman, the father of the jeweler.

Sometime during last Friday night the store of M. C. Wells, Main St., Towanda, Pa., was entered by burglars, and a large quantity of watches and jewelry taken. The thieves gained an entrance by prying open the rear door.

Yon Yonson's jewelry store, Huguenot St., New Rochelle, N. Y., was the scene of an attempted robbery on the morning of June 11. The windows in the rear of the store were broken. The thieves were scared away by Mr. Yonson.

On June 23, the wedding of E. H. Froelich and Miss Minnie Wild took place at the parsonage of St. Michael's German Lutheran Church, Harrisburgh, Pa. Mr. Froelich is a son of Mr. John Froelich, a well known merchant of that city, and is a jeweler in Kane, Pa.

Herman B. Lodde, Lafayette, Ind., will soon occupy handsome new quarters. Work was begun last week on the erection of a two-story brick building on the lot adjoining his present room on the east. The room will be 60 feet deep and will be occupied by Mr. Lodde as soon as completed.

A telegram received at Lyons, N. Y., June 19, from Brooklyn announced the death in that city of the wife of president Orlando F. Thomas, of the Manhattan Silver Plate Co. and the Bank of Wayne. Mrs. Thomas has been confined to her bed in Brooklyn since October last with consumption.

The jewelry store of W. S. Musselman, W. Broad St., Quakertown, Pa., was broken into last Saturday night and robbed of about \$500 worth of jewelry and silverware. The thieves gained entrance by cutting a hole in the ceiling from the room above the store. A man named Frank Nuttley was captured at Lansdale. He had a bundle of jewelry.

### Canada and the Provinces.

The stock of W. B. Boxall, Toronto, was sold at auction June 24.

H. Pollock, of the jewelry firm of H. Pollock & Co., Winnipeg, Man., died last week.

A. Frank, of Goldsmith & Frank, New York, has been in Toronto on a business trip,

C. H. Clark, representing the Rogers Silver Plate Co., New York, was in Toronto lately.

The stock of J. L. Mitchell, Halifax, N. S., was taken possession of under bill of sale, last week.

C. A. Wisner, jeweler and druggist, London, Ont., has sold out his drug business to A. W. Spence.

Samuel C. Hood, Yarmouth, N. S., has registered consent for his wife, Annie E. Hood, to do business in her own name.

Robert Cox, Enterprise, Ont., assigned to G. D. Hawley, and a meeting of creditors was held on June 27th. Liabilities \$2,000.

On the 24th inst., Miss Ida Kent, daughter of Ambrose Kent, retail jeweler, Toronto, was married to Rev. T. Egerton Shore, M. A., B. D.

Among Provincial buyers in Toronto last week were: W. B. Webb, Allendale; A. Galbrath, Shelburne, and W. R. Jackson, St. Thomas.

**O. NEWMAN,**  
Gold and Silver Electro-Plater.  
Etruscan Coloring a Specialty.  
WATCH CASE POLISHING.

75 Nassau St., Room 8 Rear Building, New York.

**H. M. RICH & CO.,**  
Jewelry - Auctioneers,  
21 School Street,  
BOSTON, MASS.

**Fashions and Novelties in London.**

AMONG the novelties the jewelers of London are having a run on are modeled figures of red Indians, perfect little works of art in bronze colored in faithful imitation of nature. One is of a Cherokee or Mohawk warrior with his bark canoe; others represent him executing a war dance, crouching beneath his shield in a posture of defence, or resting after the toils of battle, wrapped in his buffalo robe. Another novelty is an inkstand and table-gong combined, the former composed of a silver mounted ram's horn representing a dolphin. Sets of silver five o'clock tea knives—some shaped like the old pistol handled knives in



STERLING SILVER INKSTAND AND BELL.

miniature, others with shell design or fluted handles—form another novelty in good demand. Small silver cases for engagement rings are quite unique; and a new idea for a wedding present is the Marlborough perfume burner, shaped like an ordinary cut-glass scent bottle, with a handsome silver top, but containing a wick, which, when lighted, heats an aluminium ball that diffuses a delicious fragrance through the room. Military badges, mounted as paper weights on leather stands of any regimental colors, make effective ornaments for the writing table.

Watches to be fixed to the handle-bar of a bicycle are having a good sale in London, and



MOHAWK WARRIOR WITH CANOE.

ladies' cycling belts in silver mounted leather, with a purse secured in a side pocket by a spring, are both smart looking and convenient.

Bags of every conceivable description are sold in large quantities, from the Queen Anne carriage bags in crimson, green and other tints of crushed morocco, reminiscent of the reticules of our great-grandmothers, to kit and

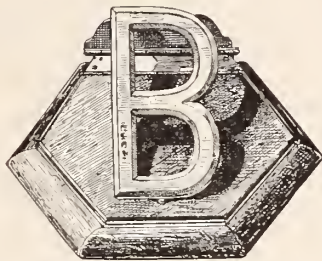

STERLING SILVER PAPER PRESS.

knockabout bags in a variety of sizes and leathers, with expanding mouths and delightful holding capacity. Beautifully enameled pendant watches in the new *émaille sur argent*; turquoise butterflies, made to fix with a hidden spring to any part of the dress, as if momentarily poised there; little silver charms to ornament exhibition tables; Algerian belts with rococo buckles; serviette rings in pierced silver, with twisted initials; delightfully fitted miniature writing boards for traveling offer a range of selection for wedding gifts. The silver taper and sealing stand in the illustration is a new accessory to the writing table.

A charming old world engagement ring is among the latest novelties a fashionable London jeweler is making. Our great-grandmothers loved to wear three narrow gold bands, closely set all round with stones; one, say, a ruby circlet, the second an emerald, the third

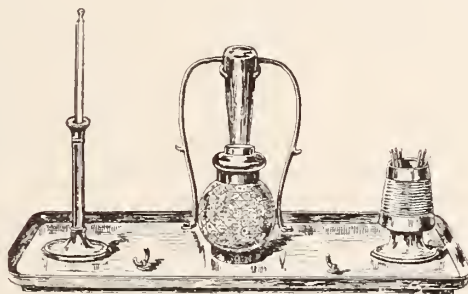

INK STAND, WITH SEALING TRAY, &C.

a diamond. This is the idea revived as a novelty. It is intended that the bride's birth-month stone and that of her fiance shall adorn two of the bars, and that the diamond, the emblem of innocence, shall go between to link the couple together. This is the sort of ring that the young man gave his sweetheart in the fashionable period of 1830.

**A Jewel of a Wife.**

A certain Russian nobleman visiting Paris was noticed to be constantly plunged in deep sadness. He wore on his finger a very remarkable ring, large enough for a bracelet, and which extended over his hand like a buckler for the ring finger. It was of a greenish color and was traversed by red veins.

A lady, meeting him in public, ventured to say:

"You wear a very handsome ring."

"It is not a ring," he answered, "but a sepulchre."

"This jewel," he continued, "is my wife. I had the misfortune to lose her some years since in Russia. She was an Italian, and died the bed which awaited her after this life. I carried her body to Germany, where I was acquainted with a celebrated chemist, whom I directed to make of the body a solid substance which I could carry about with me. Eight days after he sent for me and showed me the empty coffin amid a horrid collection of instruments and alembics. The jewel was lying upon the table. He had, through means of some corrosive substance, reduced and compressed that which was my wife into this jewel, which shall never more leave me."—*Chips*.

**IT HAD A DIFFERENT RING.**

"As a new woman," he said, "I suppose you will object to the wedding ring as a symbol of man's tyranny."

"Of course I shall," she replied. "Under no circumstances would I consent to wear such a thing. It is not essential to a marriage and it stands for all that is objectionable in the marriage relation."

"And on the same theory," he continued, "I suppose you will refuse to wear an engagement ring also."

"Well—no," she answered slowly and thoughtfully. "That's a very different matter."

"But, theoretically it—"

"There is no use arguing," she interrupted. "I don't care what it is theoretically. Practically it is very often a diamond, while the wedding ring is only plain gold, and that makes all the difference in the world."—*Chicago Post*.

**AMONG THE HEALERS.**

It was a social occasion which had called together a number of men who are eminent in their respective professions. The person who asked questions was there, and, as soon as he was able, engaged the attention of the man who knows everybody.

"Who is that man with the dark glasses?" was the first inquiry.

"That's Dr. Lensen."

"What is his business?"

"He's an oculist."

"And who was the gentleman who put a speaking trumpet to his ear every time anybody spoke to him?"

"That's Dr. Tympan."

"Has he a speciality?"

"Yes. He's an aurist."

"And the man who has such a phenomenally husky voice; who is he?"

"That is Dr. Eppa Glottis. He's the famous throat specialist."—*Detroit Free Press*.

**LOVE WILL FIND A WAY.**

He pledged his heart, he pledged his love,

He pledged his promise sweeter,

And then to buy the engagement ring,

He pledged his gold repeater.—*Puck*.

DEPARTMENT OF  
**ADVICE AND CRITICISM**  
 ON  
**RETAIL JEWELERS' ADVERTISING.**

[This department is free to every retail jeweler and optician. Forward for criticism your newspaper ads., booklets, catalogues, novelties, circulars, etc. Ask advice and offer suggestions. Replies in these columns are unbiased. Make letters as full and particular as desirable. Every letter and ad. sent will receive full attention, though the publication of the matter may sometimes be delayed a week or two. Address all letters and other matters to The Jewelers' Circular Pub. Co., 189 Broadway, New York.]

**PART XIX.**

WOOSTER, O., June 13, 1896.

Editor of THE JEWELERS' CIRCULAR:

I herewith send you booklet for criticism. This little book I got printed here in Wooster at \$5.00 per thousand. I located in this little town 18 months ago with a handsome store and stock of \$20,000. The first thing I did was to advertise in all of the county papers that I would deliver free of charge and keep in order a fine (Vamoose, New Haven), clock to all elhures within a radius of 10 miles of Wooster, my card being painted in gold on the front glass. I have given away 50 of these clocks (cost \$5.40 each) in this county; it is the best advertising I have ever done and brings to me as customers the best people in the county. I am better known in this county after a residence of 18 months in the State than my competitors who have been in business in this town for 20 years.

Respectfully,

W. H. BRADSHAW.

The pamphlet which Mr. Bradshaw sent with the above letter consists of 12 pages, 4½ x 3 inches. The front disclosed the title "Time" and a cut of the trademark of the Rockford Watch Co., "Quick Train Rockford Watch." The second page contains a half tone illustration of the interior of the store. Four pages are devoted to general reading matter about time, watch repairing, the classes of goods sold at the store, and a warning to the people of Wooster against having dealings with transient opticians and spectacles peddlers. Three pages are given over to a reprint of the birth-month gem poem. The letter press is printed in red ink. As a general advertising device, this pamphlet has some effective elements. The dissemination of the birth-month gem poem is conducive to an increased sale of gem jewelry. It is not unlikely that many of the recipients of the little book will retain it if only because it contains unique information, namely the sentiments of gems in relation to the different months.

Inasmuch as the cost, \$5.00 per 1,000, is not excessive, and as the book, we presume, is not circulated through the mails, but is given to visitors to the store and other persons without any direct cost for distribution, the advertisement gained is cheap. However,

the device is not a bringer of immediate business. In advertising by the retailer to the public, immediate returns can be obtained only by the specification of goods, with descriptions and prices. Such matter is susceptible of being presented to the public in an unlimited number of ways, but the foregoing elements must be embodied.

Therefore, if Mr. Bradshaw distributed his pamphlet in "one fell swoop", he would have added greatly to its business-bringing ability if he had described—with illustrations if possible—and given the prices of a number of timely and seasonable goods. In this circumstance the book would have really been an advertisement of certain lines, presented in an agreeable and attractive manner.

The clock scheme evidently achieved its purpose, and therefore must be accepted as being a good one. If Mr. Bradshaw's gauge of its results is not too highly colored, the \$270 which the scheme cost, besides that for newspaper advertising, was money well expended.

\* \* \*

The following clipped from a Washington, D. C., daily, is a neat and impressive specimen of a general ad. The arrangement and

WASHINGTON, D. C.  
**NEW STOCK.  
 NEW PRICES.**

**Louis XV**

Style of design in silver, while not new, is by reason of its extreme beauty, a permanent favorite.

We have a choice variety of single pieces in this pattern, massive and rich.

A princely wedding gift can be selected here for a comparatively small sum.

**J. KARR'S SONS,  
 JEWELERS, 945 Pa. Av.**

style of type lend themselves to easy reading of the ad., which is an important element in all advertising, with the exception of that puzzle variety of ad. which produces effect if sparingly used. The

ad. announces a pattern in silverware which maintains its position as a favorite. The matter is well worded and possesses tone, but we do not see why the "new prices" are not specified. Undoubtedly J. Karr's Sons' competitors in the trade know their prices on this pattern; and if they are averse to bringing their prices, which may be higher, in opposition to those of the drygoods stores, they should point out strongly that the Louis XV. is a pattern made exclusively for the jewelry trade, and is the embodiment of all knowledge acquired during years of study and experience by one of the foremost houses in the silversmithing world; and should specify with prices pieces which the drygoods stores perhaps do not handle or cannot sell any cheaper than the jewelers. Tiffany & Co., New York, announce occasionally the price per ounce of their flatware, and we do not think they suffer by this method.

\* \* \*

A Philadelphia jewelry firm, while using a little amount of space, produce effective ads. They usually advertise a distinct, timely line of goods, and occupy from 2½

"I don't want to wear the same belt every day." You don't have to—if you've got one of our leather belts—we sell extra leathers to fit our buckles and you can change in an instant, without trouble, to any color you like. With one buckle, you can have belts to match any costume.

Just stop here, and see how.

to 3 inches of space at the foot of a reading column. The ads. are always set in the same type, namely 10 pt. Old Style, without display lines or borders. The ads are clear and readable, and their phraseology has the ring of truth. We reproduce three of these ads.

There are numerous readers of newspapers who find more items of interest at the bottoms of the

columns than at the tops. These readers are really searches for tidbits and the ads. possess as lively interest to them as the reading matter. Again there are numerous readers who read head lines and pass their gaze rapidly to the bottoms of the column to learn the

1000 Solid Silver Buckles with silk webbing, \$1.25 to \$2.50 each. Were \$3.50 to \$6.00 each. Prices reduced because we don't want to carry them to next season.

The finest buckles. Nothing light or "tinny" about them. If you picked 'em up on the roadside they wouldn't be much cheaper.

A nice belt always comes in, doesn't it?

Delft—a small but choice lot of the real thing—Joost Thoofft & Labouchere—has just come to us. We have made the prices extraordinarily low, so low in fact that the imitation of German Delft isn't worth anything by comparison.

When you can buy real Dutch Delft Vases for \$3.25 who wants the other?

conclusions of the incidents. It may be safely asserted that as many persons see the bottoms of the newspaper columns as the tops, and in several papers like the New York Sun and Philadelphia Times, in which the short columns are filled out with humorous, chic and interesting short items, "bottom of column" is as good advertising position as "top of column."

\* \* \*

**Recent Good Ads.**

[Under this heading will be reproduced good ads. (introductory portions only) culled from various sources.]

[Printers' Ink.]

**GOOD EYES**

Are at a premium nowadays. Constant straining soon causes defective vision. We offer you, free, the services of our competent oculists, who will advise you correctly. Reasonable charge for glasses.

Examination of the Eyes Free.

**NO CHARGE**

Step in and have your watch regulated, no charge if bought of us or not, you will receive the same courtesy. Our watchmakers have 20 years' experience. A class of the finest watch repairing done in the Northwest. We solicit watches by express and give prompt attention. Clocks called for and delivered.

**JACOBS & CO.,  
 Jewelers,  
 410 Nicollet Avenue.**



## MATTERS IN JEWELRY STOREKEEPING.

That this department shall prove mutually beneficial to our readers, it is desirable that the members of the trade generally communicate with THE CIRCULAR regarding any advantageous device or plan that they are utilizing in connection with their business.

### Attractive Actresses in Jewelers' Windows.

SIXTH avenue pedestrians were much surprised to see what appeared to be the head and shoulders of a well known variety actress peeping coyly from a jeweler's window the other day. What was more astonishing, the actress was fairly covered with jewels; ears, coiffure, throat, neck and shoulders all ablaze with gems. What could it mean? Had the enterprising shop keeper hired the actress at so much a day to wear his goods and pose for the public in his store window? If so, it opened up a delightful and diamondiferous field for the profession. It might be before long that the "shop window specialty" would rank quite as high and pay probably better than a "song and dance act." A little closer investigation, however, cut short these reflections. The head and shoulders were nothing more than—head and shoulders, sure enough, but they had been carefully cut out of the actress's latest and most life-like "lith." But the scheme worked. Fully two-thirds of all the passers-by that afternoon stopped to stare in at the window with its unusual occupant.—*New York Evening Sun.*

The bust of a handsome young woman whose neck is encircled by a beautiful necklace with a diamond star pendant attracts considerable attention in the window of T. L. Bear, jeweler, 204 Market St., Camden, N. J. The poise of the head, the life-like smile and the delicate work on the drapery of the bust show that a master hand has fashioned the clay. It is the work of Frans L. Engdahl, the sculptor who has his studio in the Temple building. The subject is Miss Annie Burkam, a society girl of Cincinnati. She is a sister of Carrie Radcliffe, of the Stuart Robson Co.

### A Novel and Original Advertising Scheme.

NO advertising scheme ever attracts so much attention as one that is new, original and unique. Such a one was given to the public of Providence, R. I., recently, and in consequence the streets about the enterprising jeweler's store were packed so that the police were obliged to take action to keep the thoroughfare free for passage. The crowds also attracted the attention of an agent of the Society for the Prevention of Cruelty to Animals, who said that E. E. Hosmer must call off his mice or there would be trouble. Mr. Hosmer is the proprietor of the jewelry establishment at the corner of Westminster and Franklin Sts., and he conceived the idea of a vice-presidential mouse race. The idea worked to a charm and the rodents made more fun than a barrel of monkeys. It was

this way: Mr. Hosmer caught a dozen small mice and painted them all colors of the rainbow, so as to distinguish them. Then he placed the collection inside of a plate glass cage, which also contained a revolving disc, a flying trapeze, and several hunks of imported cheese hung a-mouse-and-a-half above the disc.

When the animals felt gay they would jump upon the disc and every time their feet would step forward the thing would fly round lickity-split. Then the mice would chase themselves and the fun began. In order to bring the contest thoroughly up-to-date the proprietor called the race a competitive contest for the vice-presidential nomination, with all due respect to the human candidates, of course. One Saturday afternoon the race commenced. At the word "go," a little red mouse with a husky squeak broke away from the field and rushed to the front at a speed which for the moment rattled his competitors. All of a sudden the red mouse was taken with a strange desire to do a circus act. He took a flying start and before he knew what had happened he found himself perched upon the trapeze. Then he filled himself with the imported cheese, grew sleepy and fell off the trapeze into a dish of water. His red coloring washed off, and when the agent of the society happened around a few hours later he told Mr. Hosmer that the show must cease. He thought the red mouse had been treated miserably.

The agent gave Mr. Hosmer until dark to cease the unique advertisement. Mr. Hosmer said that the mice were not being ill-treated, and so the show was going to continue. At dusk the agent had not reappeared, and the vice-presidential contest was still on at full tilt, although the colors of some of the contestants were considerably bedraggled. Mr. Hosmer, however, reaped a good harvest during the afternoon and evening.

### An Adventure with Burglar Alarms.

A LARGE Chicago jewelry house recently appointed a new superintendent. Prior to his arrival the duties of the position were filled by an employe, who was named as assistant superintendent.

All entrances to the jewelry house, the windows and the vaults are connected with electric wires, which run to detective headquarters, and are there attached to a burglar alarm. Something was the matter with the alarm, and it went off of its own volition three times within the week prior to the new superintendent's arrival. As soon as the alarm rang detectives were sent to surround the store, while one of their number was dispatched to the

residence of the assistant superintendent, who went down to the store, with his keys and admitted the officers.

The superintendent arrived Friday night. The jewelry store closed at noon Saturday. At 3 o'clock in the afternoon the burglar alarm at headquarters rang furiously. Officers went on a keen jump to the store, while another went as usual for the assistant superintendent. Some one had heard of the arrival of the recently engaged superintendent, and he was likewise sent for.

The assistant superintendent reached the store first, and found that the burglar alarm had gone on a strike of its own accord again, and the officers were sent back to headquarters. The assistant superintendent went home. In a few minutes the superintendent reached the store, unlocked the door, and entered. His opening the door rang the burglar alarm at headquarters once more. Down came the detectives with a rush. They found the stranger superintendent walking round in the store, peeping into this place and that place, and here and there, trying a vault door to see if it was secure. When he saw the officers he blew them up for being slow, and said that twenty places could be robbed while they were getting round.

"I am the superintendent here," he said, "and this dilatoriness shall be reported."

"Pretty good bluff, that," said a gray-headed detective, "but it won't work. See? You come along with us."

And forthwith they dragged him to headquarters. The superintendent had nothing with him to prove his identity, and he was compelled to submit to the humiliation of being taken under guard to the far South Side to have his character vouched for by a subordinate.—*Chicago Tribune.*

### The Popularity of Stick-Pins.

"MORE stick-pins are being used than ever," said a Bangor jeweler to a reporter of the Bangor, Me., *Commercial*, recently, "and I don't know where the end of the craze is to be. There are all sorts of freak things in the market and they are multiplying daily, too. Of course, the wealthy folks don't run much to these queer things—they like stick-pins all right enough but they want jewels in them and variety is expected there; it is in the cheaper grade of pins that sell amongst the small buyers that you can see a new design about once a week, and sometimes oftener. Down in my shop I've got a lot of catalogues that show all sorts of styles; there are trotting horses, Trilby feet, shoe buckles, baby's heads, revolvers, daggers, boxing gloves, death's heads, dumb-bells, skates, guns, ships, fishing rods, bicycles, nursing bottles, beer glasses and baseballs. I sell a lot of them, but the big department stores in Boston and the fakirs of the street dispose of the most of them; they bring a tremendous profit, and I have heard of at least two concerns that are making them that are growing wealthy out of the curious business."



Copyright, 1896, by The Jewelers' Circular Pub. Co., 189 Broadway, New York.

A Jeweler's Necessity

For eight months THE JEWELERS' CIRCULAR has had under way a work that will comprise the trade-marks of every branch of the Jewelry, Watch, Clock, Silverware, Silver Plated Ware, Optical Goods, Precious Stone, Art Pottery, Bric-à-brac, Cut Glass and cognate lines of the Jewelry Industry.

The work is now nearing completion. We consider it will be the most valuable book that has ever been issued to the Jewelry trade.

It is a work which the retailer and wholesaler will immediately appreciate.

It will be a book of constant reference, and will be consulted more perhaps than any other book issued to the trade.

It will be a book of daily use.

It will be sold at a figure that will guarantee its rapid distribution.

In addition to illustrations of the various trade-marks and the names and the addresses of the firms to whom they belong, and the class of goods to which they appertain, the work will contain other interesting and valuable information bearing upon the subject of trade-marks.

Members of the Trade, Manufacturers, Wholesalers and Retailers should at once place their orders for

"TRADE-MARKS OF THE JEWELRY AND KINDRED TRADES."

\$1 per copy. Bound in Cloth. Payable now or upon delivery of Book. Detach order below and forward to the Jewelers' Circular Publishing Co., 189 Broadway, New York.

ADVANCE ORDER BLANK.



189 Broadway, New York.

..... 1896  
Please file this order for ..... copy of

"Trade-Marks of the Jewelry and Kindred Trades"

for which I agree to pay \$1.00 per copy, postage prepaid, upon delivery of book.

Name.....

Street..... City..... State.....

### Caloric Engine for Watch-makers.

**J.** SCHORRBACHER, Gaimersheim-Ingolstadt, Bavaria, has invented and patented in Germany a 1-60 H. P. "hot-air motor" (caloric engine), for the use of watchmakers and small tradesmen who require but little power to propel a small machine. As the

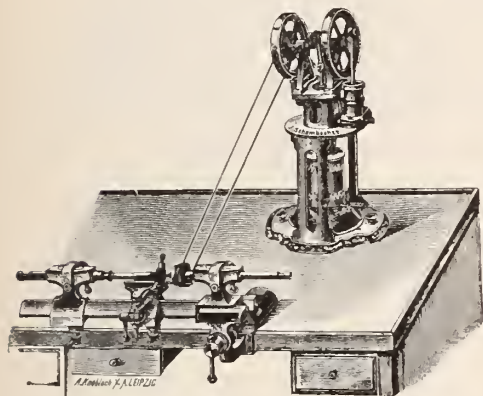

mechanism looks (on paper) quite practical, THE JEWELER'S CIRCULAR translates the article from the Leipzig *Handels-Zeitung* for the examination of its readers.

It may perhaps appear incredible, says our authority, that the watchmaker, similar to other mechanics, may with advantage use the power of a motor, yet such is the fact. . . . As shown in accompanying illustration, the motor is to be used for propeling the lathe; it has more than sufficient power, a steady, noiseless motion, and all other desirable qualities, and permits the workman to use both hands. Besides this, it will also render excellent service in drilling, fraising, grinding, polishing, etc.

For workshops with a number of workmen, a larger motor may be used, and the power may be transported by belting to any part of the shop. In this case, it is of advantage to keep up the power during work hours. The motor of 1-60 H. P. is 450 millimeters (about 18 inches) high and 200 millimeters (about 8 inches) deep and broad, and weighs 7 kilograms (about 15 pounds). The machine makes 600 revolutions per minute, and the power is large enough for all work occurring in watchmaking. The chief parts are of hard cast-steel or bronze. The machine uses alcohol, but so little that the expenses of running are barely 1 pfennig (¼ cent) per hour. The price of this 1-60 H. P. machine is 38 marks. It can also be had in the sizes of 1-40, 1-20, 1-10, and 1-5 H. P.

### Pendulum With Lever Compensation.

**T**HE compensation pendulum invented by me and described in the following article, says Herm. Fritsche, in *Deutsche Uhrmacher Zeitung*, equalizes the differences of rate caused by the changes of temperature by having the hole divided into two parts which can, corresponding to the variations of temperature, be slid up or down by means of two jointed levers. The advantages of this pendulum may be summed up as follows:

1. No mercury is used, as this volatilizes in time.
2. All steel parts are dispensed with, and no disturbances of any kind due to magnetism can occur.
3. Every watchmaker can easily make one himself and compensate it precisely, the principle of construction being similar to that of a compensated balance.

Accompanying illustration shows the pendulum in reduced size; *a* is a brass ring of about 50 millimeters diameter, 10 mm. radial thickness and 15 to 20 mm. breadth; the latter is controled by the diameter of the glass tube *l*, which is pushed from below through the ring *a*. The ring has two square notches, *b b*, on both sides, in which the weight bars, *c c*, move freely. Beside this are two knifelike bevels, *d d*, upon which the weight bars, *c c*, rest, each of a half-round filed-out shape. The two bars, *c c*, are in the center united movably one with the other by a joint *f*. Upon their ends projecting beyond the ring *a* are the two cylindrical weights, *i i*, which can be displaced by means of the rating screws, *k k*, that is, advanced nearer to the center of the ring, or withdrawn farther from it.

Upon the central part of the joint *f* rests a sort of cup *g*, in the hollow of which lies the screw *h* with its point. This screw, the length of which may be varied, forms the lower end of a brass rod *m* contained loosely within the above-mentioned glass tube *l*, and which braces with its upper end against the cap *p*, in which the upper end of the tube *l* is fastened. The diameter of the tube is 10 mm., the sides

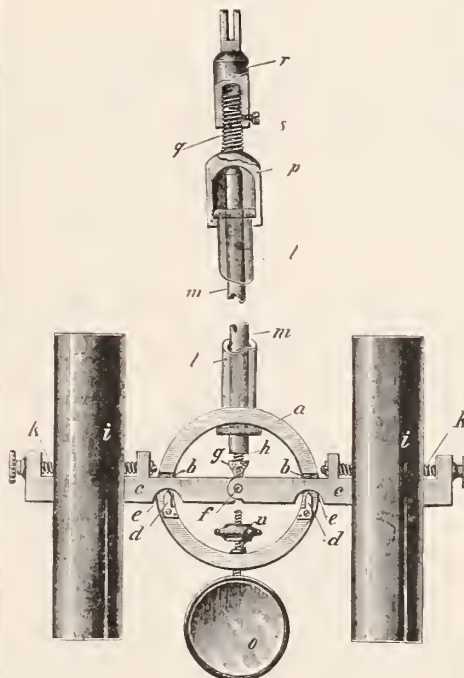

are 2 mm. thick; the diameter of the brass rod is about 5 mm. For the sake of fastening the glass tube *l* more easily, I have on each end melted a strong glass ring.

By aid of the movable screw *h*, the two weight bars *c c* are set in such a way that in mean temperature they stand truly horizontal. The

weight of the bob—by which in this case all the parts from *a* to *k* are to be understood—is borne by the glass tube *l*, while the brass rod *m*, which expands much more than glass, has to effect the compensation. The brass rod is regulated by the displacement of the two weights *i i*; if the compensation is too little, the weights are moved outward, and the reverse.

The cap *p* ends above in a heavy thread *q* which seizes in the shell *r* of one piece with the pendulum hook. By means of this thread is effected the bulk of the rating of the clock, after which the parts *q* and *r* are fastened by the set screw *s*. The mean-timing, that is, a daily difference of at most one minute, is done by screwing higher or lower the rating screw *n* at the lower part of the ring *a*. For the last close rating is a cup at the upper end of the pendulum rod (the cup is not shown in the sketch), in which small weights are placed during the going of the clock, and from which they may be withdrawn as readily. At the lowest end of the pendulum is a mirror *o*, usual with astronomical pendulum clocks, to show the slightest trembling of the pendulum. Since brass extends one-half more than glass, the length of rod and tube may be about the same; the main part of the compensation is at any rate effected by displacing the weights *i i*. If any one objects to glass on account of its great fragility, he may use a steel tube. I used such a pendulum for the last two years, and its rate is perfect.

### French Drum Clock.

**A**S is known, there is a small French clock inclosed in a brass cylindrical case called the "drum clock." Its chief distinguishing feature is that it never goes for any length of time. The escapement is a continual source of trouble to clock repairers. It receives impulse at every other vibration only. The clocks have going barrel and the idea of the escapement appears to be that by providing a long frictional rest at one of the pallets, the extra pressure of the scape-wheel tooth when the mainspring is fully wound, will be sufficient to prevent any considerable increase in the arc of vibration of the pendulum. But the clocks often stop from deficiency of power when the spring is nearly down, and stop when they are fully wound, because the small and light pendulum has not energy enough to unlock the pallet. The best that can be done is to alter the resting pallet to a straight form, and see that the wheel teeth and pallets are well polished.

**Concerning Pivots.**—Pivots must be hard, round, and well polished; their shoulders are to be flat, not too large, with ends well rounded off so that they do not wear the cap jewel.

**Good Mucilage.**—An adhesive mucilage for labels, suitable for bottles or glass may be prepared by soaking glue in strong vinegar, then heat to boiling and add flour. This paste is very adhesive and does not decompose.

# OPPENHEIMER BROS. & VEITH,

CUTTERS OF DIAMONDS,

DEALERS IN WATCHES,

65 NASSAU STREET (PRESCOTT BUILDING), NEW YORK.

These well-known Razors, the quality of which is warranted, possess this great advantage, that they may be used for ten years before they require actual sharpening. Before using them, it is necessary to rub them on good leather strop. Lecoultre's Strops (to be had with the Razors), should be used in preference to others.



THIS CUT IS TWO-THIRDS OF REGULAR SIZE.

## MATHEY BROS., MATHEZ & CO.,

SEND FOR PRICE LIST

SOLE AGENTS. 21 & 23 Maiden Lane, N. Y.



### MARINE CHRONOMETERS,

MANUFACTURED BY

John Bliss & Co., 129 Front St., New York.

We have on hand a number of Chronometers, by various good makers, not new, which have been in service for purposes of navigation, and are excellent instruments. They have been put in perfect repair and will give satisfactory results as to performance. We will sell these Chronometers at low prices, either for cash, or on accommodating terms to suit special cases, or will hire them at moderate rates and allow the hire to apply on purchase.

SEND FOR CIRCULAR GIVING PRICE & AND TERMS.

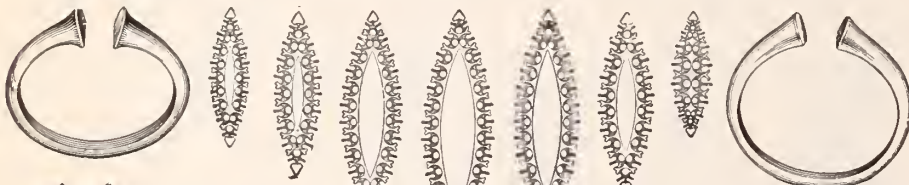

NO SOLDER.

NO SEAM.

SAVE TIME AND MONEY.

Superior to Anything Ever Shown.  
Apply for Catalogue to

CHAS. BACHEM, 249-251 N. J. R. R. AVE., NEWARK, N. J.

Manufacturer of

Marquise Heads, Clusters, Ring Shanks, Gypsy Rings, Etc.



# HENRY FERA,

IMPORTER AND CUTTER OF

## DIAMONDS

PRESCOTT BUILDING,

65 Nassau St. cor. John NEW YORK.

FACTORY

60 Fulton St., NEW YORK.

Cutting for the Trade a Specialty,

ESTABLISHED HALF A CENTURY.

**MARVIN'S**  
FIRE & BURGLAR

**SAFES**

HAVE MANY PATENTED IMPROVEMENTS

NOT FOUND IN OTHER MAKES

THAT WILL WELL REPAY AN INVESTIGATION

BY THOSE WHO DESIRE TO SECURE

THE BEST SAFE  
MARVIN SAFE CO.

12 PARK PLACE, NEW YORK.

## THE SWAN FOUNTAIN PEN

Reputation World Wide.

Made upon Distinct Principles.

Is a Compressed Air Pump.

Simply Wet the Insides to Provoke an Energy.

W. W. Stewart, Inventor and Patentee.

A variety of Styles and Prices

3 Sizes Safety Swans.

3 Sizes Self-filling Swans.

3 Sizes Adjustable Feed Swans.

MABIE, TODD & BARD,

NEW YORK AND LONDON.



## The Rambler's Notes.

WHAT THE RAMBLER SAW AND HEARD AMONG THE DEALERS IN ART POTTERY, CUT GLASS, BRONZES, ETC

A NEW LINE OF GEO. JONES' **H**ALF a dozen entirely new and artistic decorations in Geo. Jones' Crescent china may be seen in the warerooms of Chas. Ahrenfeldt & Son, 52 Murray St., New York. The goods which have just been put on exhibition are principally plates, trays, cups and saucers, teapots, sugars and creams. One very pretty decoration shows a border consisting of a mass of small green flowers on a background of gold.

**ARTISTIC LAMPS**  
IN VARIETY. **G**EO. BORGFELDT & CO. have just opened several hundred varieties of lamps in large banquet and princess sizes which are to be seen in the firm's art goods department on the 3d floor of 18-22 Washington Place, New York. The lamps are of china and opalescent glass mounted with gilt, and have detachable founts. All varieties of decoration are shown including Delft, Dresden, large and small flower, fleur de lis and gilt styles. The colorings of many pieces are exceptionally fine.

**VIENNA**  
"ETAIN" PIECES. **T**HE line of Vienna Etain pieces just put on display by Ferd. Bing & Co., 10 Washington Place, New York, is expected to prove very popular with the jewelry trade. Fine ornamental pieces in jardinières, vases, paper weights, ink stands, trays, etc., show finely modeled figures, and are in silver and bronze finish. A very large vase has a fine treatment of water effects, and shows two well modeled mermaids. Paper weights are formed of large and small groups of dogs, and figures and groups of wheelmen. The card trays are handsomely embossed.

**SILVER-MOUNTED**  
**CUT GLASS.** **B**EAUTIFUL specimens of cut glassware mounted in sterling silver have been added to the cut glass department of L. Straus & Sons, 42-48 Warren St., New York. Among the most prominent articles are claret and

champagne jugs with richly embossed wide silver bands, cigar and tobacco jars and bon-bon boxes with silver tops. The firm's richest cuttings are shown in the pieces mentioned.

**CUPID**  
DECORATIONS. **C**UPID panels and decorations, involving cupid treatment, are now being extensively shown in the products of the Royal China Decorating Co., 35 Warren St., New York. The artists employed by this company at their factory in Jersey City, where the French china blanks are decorated, have spent much time and effort in perfecting this style of decoration, and the work they now produce is hardly surpassed, even in the finest imported wares. Trays, plaques and plates of all kinds are among the principal pieces on which this cupid treatment is seen.

**NEW CUT**  
GLASSWARE. **T**HE Empire Cut Glass Co. are now more than ever before devoting their efforts to the production of the finest and most expensive cuttings, and large, rich articles of cut glassware. One of the latest high-grade patterns to be shown at their warerooms in the Para building, Warren and Church Sts., New York, is called "Cyrana," and contains elaborate rosette work. A pretty and brilliant yet inexpensive new pattern is the "Bermuda" which appears on a full line of articles common to cut glass. A new line of cigar, tobacco and cigarette jars is now in preparation.

## Pottery Over 3,000 Years Old.

**I**N digging out the colossal statue of Rameses II., 9 ft. 4 in. of Nile mud had to be removed before the platform was reached. It is known that this platform was laid in the year 1361 B. C., when Rameses was still living. Therefore 3½ in. of accumulated Nile mud represents the lapse of a century, it being known that 3,200 years have passed since the platform was put down. Under that platform was found 30 ft. more of Nile mud before the original sandy soil was reached, hence many years must have elapsed from the time of the Nile's first overflow down to the time of Rameses II. The curious part of the story is

this: Pottery and fragments of the same were found on the original sandy soil 30 ft. under the base of the statue, which would seem to indicate that the Egyptians understood the potter's art at a very early date.

## TEAR BOTTLE.

**G**LASS, wherein a Greek girl's tears  
Once were gathered as they fell,  
After these two thousand years  
Is there still no tale to tell?

Buried with her in her mound  
She is dust long since, but you  
Only yesterday were found  
Iridescent as the dew—

Fashioned faultlessly, a form  
Graceful as was hers whose cheek  
Once against you made you warm  
While you heard her sorrow speak.

At your lips I listen long  
For some whispered word of her,  
For some ghostly strain of song  
In your haunted heart to stir.

But your crystal lips are dumb,  
Hushed the music in your heart;  
Ah, if she would only come  
Back again and bid it start!

Long is Art, but Life, how brief!  
And the end seems so unjust;  
This companion of her grief,  
Here to-day, while she is dust!

—Atlantic

## Stray Fragments.

Queen Victoria owns £400,000 worth of china.

Bowls, dishes and plates are made from the hair of rabbits and other animals in Russia. The articles are felted and afterward varnished. The utensils have the appearance of papier maché or varnished leather.

About the year 680, it is said, the first glass window was put in. The Romans are credited with being the makers of the first glass bottle made in the world. This was about the year 70. Glass bottles were not made in England until 1558.

In China the mixing is stored for two or three years, but in Meissen ten months is considered sufficient. This storing is most important. There are still supplies of the oldest porcelain clay found near Aue, in the Erzgebirge, which gives a reddish tone to the paste; it is used for particularly delicate figures.

**Black Diamonds From Coal Gas.**

**M.** GUSTAVE ROUSSEAU recently communicated to the *Comptes Rendus* a remarkable statement referring to his experiments upon the cyclical condensation of carbon. It appears that, in the course of some investigations into the nature of certain manganese, cobaltites, and ferrites, M. Rousseau obtained some metamorphoses which led him to the discovery of a new phenomenon in chemical physics—that is to say, the so-called cyclical transformations to which can be subjected a particular radical under different temperatures. Thus certain compounds of manganese and soda can be formed at a given temperature, changed into something different by raising the temperature, and finally reconverted into the original compound at a still higher heat. From these analogies, M. Rousseau thought that, if hydrocarbons were heated through the range of temperature between bright red and 3,000° C., there might be produced in turn the various isomeric states of carbon, each of which presents its own degree of stability according to its place in the thermometric scale. It is known that the hydrocarbons form amorphous carbon by decomposition at red heat; while all varieties of carbon are transformed into graphite in the voltaic arc. M. Rousseau claims to have established the novel fact that carbon presents the cycle graphite-diamond-graphite in an interval of temperature comprised between

2,000° and 3,000° C. He worked with acetylene to solve this problem, because this carbon compound has a certain stability at high temperatures, and is endowed with a marvelous plasticity, besides polymerizing easily into a series of carburets more and more condensed. Acetylene was heated in an electric arc furnace, producing both black diamonds and graphite. The experiment was of a difficult character; and much acetylene escaped treatment.

Mr. Rousseau says that the hydrocarbons of coal gas can be made to furnish acetylene, under the action of heat; and in one experiment of forty minutes' duration, he was able to obtain twenty milligrammes of black diamond in this way: He caused a current of illuminating gas, saturated with vapor the of benzine, to pass into a hallow block of quicklime, where the voltaic arc was maintained. Unfortunately, owing to leakiness of the furnace, the gas burned; and after two hours' heating, he could only find a small quantity of graphite mixed with some grams of carbonado. M. Rousseau proposes to continue these experiments, with a furnace hermetically sealed, and constructed of refractory material not containing carbonates. He also intends to substitute for coal gas the highly condensed carburets derived from coal tar or petroleum residuum.—*Journal of Gas Lighting.*

**Oil for Lubricating.**—I tried the experiment of mixing enough graphite obtained in its finest powder from one of the graphite

crucible companies, with a high quality of watch oil, to make a pasty mass. The lubricant has kept its place for two years, remaining unchanged, and is a striking example of the value of a lubricant made up of the permanent qualities of graphite and the wastening qualities of the watch oil. In adapting such a lubricant to clocks and watches, two difficulties will present themselves. The mixture of the graphite and the oil being mechanical, the graphite will gradually settle to the bottom of bottles holding it, and next, it is difficult to get a powdered graphite free from grit. Both these difficulties can be overcome, the second most easily, by preparing the graphite by some method of precipitation which will give the final powder an impalpable form.

A well known optician in England sells a thousand glass eyes a year, and he reckons that the number of glass eyes used annually in the United Kingdom is about fifty thousand. The average life of a good English glass eye is 12 months. Some people wear two glass eyes for the sake of appearances; and it is very difficult indeed to tell a glass eye if it fits properly. Teardrops gradually destroy the enamel of the glass eye, and nothing has been discovered to resist the acid contained in a tear. Many ladies with artificial eyes have secured husbands; and, indeed, play can be effectively made with a glass eye. Winking is even possible.



**W. T. F.**

Means everything that is first quality in Watch Glasses.

They are used by more Watch and case makers than all others.

Their success has induced others to copy the label but not the quality.

**J. R. WOOD & SONS,**  
21 & 23 MAIDEN LANE, NEW YORK.



**PLAIN SOLID GOLD RINGS.**  
**SEAMLESS PLAIN SOLID GOLD RINGS.**  
**ENGRAVED AND CHILD'S RINGS.**  
No Ring Stamped Different from Quality.  
Send for Catalogue and Price List.

Old Gold and Silver received and estimated on: If amount allowed does not give satisfaction, notify at once and will return at our expense, in same condition as received.

**DR. KNOWLES' PRIVATE COURSE IN OPTICS.**

Lectures with Diploma \$25.00  
Those who desire to study with the Doctor will send in their application.  
Students received at any time.  
CORRESPONDENCE COURSE PERFECTED.  
*The Key to the Study of Refraction.*  
50c. per copy,  
For Sale by  
**R. H. KNOWLES, M. D.,**  
189 Broadway, NEW YORK.  
Care of JEWELERS' CIRCULAR.

**CROUCH & FITZGERALD.**



**Jewelry Trunks and Cases,**  
161 Broadway,  
Bet. Cortlandt and Liberty Sts.,  
688 B'way,  
701 8th Ave.,  
NEW YORK.

**A. J. COMRIE,**  
AUCTIONEER,

22 John St., N. Y.  
SPECIAL SALESMAN OF WATCHES, DIAMONDS.  
BRIC-A-BRAC, FOR ESTABLISHED JEWELERS.  
WRITE FOR PARTICULARS

**JACOT & SON,**

Importers and Manufacturers of  
**Musical Boxes,**  
39 Union Square. New York

**QUICK SELLERS.....**

IN STERLING SILVER ARE MADE BY  
**CODDING BROS. & HEILBORN,**  
North Attleboro, Mass.



**The STATIONERS' ENGRAVING CO.,**  
98 TO 102 NASSAU STREET, NEW YORK.  
MAKERS OF  
WEDDING INVITATIONS, RECEPTION AND VISITING CARDS  
of the Best Quality, which are offered to Jewelers of recognized standing only.  
Trade Mark "SILVER WHITE," registered.



**THE QUESTION ?**  
 WILL IT TARNISH Need  
 not be asked if your Tissue Paper bears  
 this label.

MANUFACTURED BY  
**C. H. Dexter & Sons,**  
 WINDSOR LOCKS, CONN.

◁ BE SURE YOU GET THIS BRAND ▷

It has been adopted and is now used by the leading  
 manufacturers of this country.

**ENAMELERS** ❁ ❁

OF GOLD, SILVER AND PLATED JEWELRY,  
 Enameled, Plain and in Colors  
 ALSO OF  
**SOCIETY EMBLEMS,**  
**YACHT AND COLLEGE FLAGS.**  
 All Varieties of Painted Enamel Work.

**S. S. WILD & SON,**  
 179 Eddy Street, PROVIDENCE, R. I.

Correspondence Solicited.  
 Telephone Connection.

**Watchman's Improved Time Detector**  
 12 and 24 Different Keys with  
 Safety Lock Attachments.

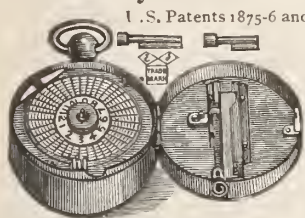

U. S. Patents 1875-6 and 7. Reissued, 1880  
 This Watchman's  
 Time Detector con-  
 tains all latest im-  
 provements. The  
 only perfect instru-  
 ment in the market.  
 It cannot be tam-  
 pered with success-  
 fully. Warranted  
 in every way

Send for circular  
**E. IMHAUSER,** 206 B'way New York  
 U. S. A.

DON'T FORGET THE JEWELERS' CIRCULAR PUB-  
 LISHING CO'S BOOK LIST when in want of any tech-  
 nical book in the Jewelry or Kindred Trades.

**A** ESTABLISHED 1872.  
INCORPORATED 1894.  
**AMERICAN WATCH TOOL CO.**

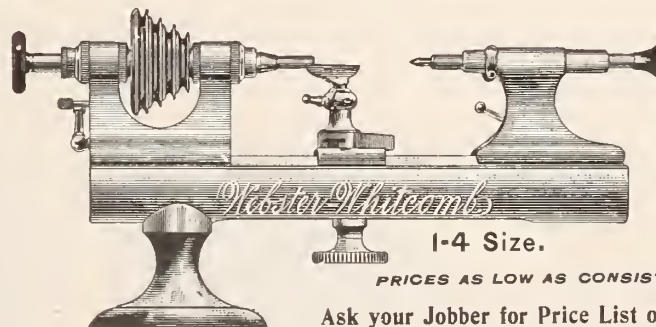

THE  
**Webster-Whitcomb**

1-4 Size.

GROWS IN POPULARITY

PRICES AS LOW AS CONSISTENT WITH QUALITY.

Ask your Jobber for Price List of 1895, or write to us at

**Stoney-Batter Works, Chymistry Dist., Waltham, Mass.**

**PAILLARD = = WATCHES**  
**NON-MAGNETIC**

ARE AS GOOD AS THE **BEST.**

**R. A. LOVELAND,** IMPORTER, 177 Broadway, New York.

**AIKIN, LAMBERT & CO.,**

MANUFACTURERS OF

**FINE GOLD PENS, HOLDERS, PENCILS,  
 TOOTH PICKS, and NOVELTIES.**

PAUL E. WIRT FOUNTAIN PENS, at new and lower prices  
 MERCANTILE FOUNTAIN PENS, guaranteed to give satisfaction.

Catalogues with terms and discounts furnished to the trade.

BRANCH, 103 STATE STREET, - - - CHICAGO.

**19 MAIDEN LANE, NEW YORK.**

**AIKIN-LAMBERT JEWELRY CO.,**

IMPORTERS OF

**DIAMONDS.**

JOBBERS IN

**WATCHES, JEWELRY, CHAINS  
 NOVELTIES, ETC.**

LATEST DESIGNS.

LOWEST PRICES



**CYCLING PROGRESS  
EXEMPLIFIED.**

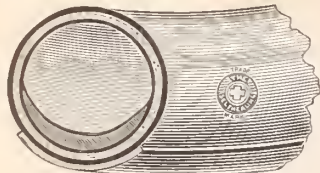

**THE WONDERFUL  
SELF-HEALING TIRES**

are single tube, finest rubber, finest wove Sea Island cotton fibre, re-enforced inside and outside on tread, and no better tire can possibly be made. They are fully guaranteed against all climatic changes, are the most resilient ever made, and when punctured instantly heal the wound of their own volition.

THEY WEIGH NO MORE THAN OTHERS,  
COST NO MORE,  
AND ARE WORTH TEN TIMES MORE.

— SEND FOR TIRE BOOKLET —

**Wm. H. CAHN, GENERAL MANAGER,**  
48 and 50 Maiden Lane, New York.

**BY EVERY TEST THEY ARE THE BEST.  
THE UNIVERSAL FAVORITES.**



**SUPERB  
Olympic  
BICYCLES**

For sale by more than 2,000  
Jewelers, and constructed to meet  
the demand for finest quality.

For Adults and Juveniles.

**SEND FOR EXQUISITE  
CATALOGUE.**

Top Grade "Olympics" have **SELF-  
HEALING TIRES.**

Olympic Cycle Mfg. Co.,

N. Y. Office: 35 LIBERTY STREET

**General Jobbing Ag'ts, S. F. MYERS & CO.,**

**WHOLESALE JEWELERS,**

Myer's Building, New York.

**RECEIVER'S SALE!**

**TRADE OPPORTUNITY.**

Entire Stock of

**CHAS. JACQUES CLOCK CO.,**

22 Cortlandt St., New York,

**...Must Be Closed Out...**

**Latest Paris Novelties,  
all New Importations  
of this Spring**

Together with **LARGE STOCK** of

**ELLIOT CHIME CLOCKS,**

And a Fine Line of Other

**HALL CLOCKS.**

By order of

**ALBERT C. WALL, Esq.,**

Receiver.

**BAWO & DOTTER,**

26-32 BARCLAY ST.

NEW YORK.

P. O. Box 1872.



**NO LARGER STOCK**

OF

**HALL  
CLOCKS**

IS SHOWN IN  
THIS CITY.

Large Stock  
OF  
**MOVEMENTS.**

**NEW DESIGNS  
IN CASES.**

**STERLING**

Sheet and Wire Supplied. All Sizes.

**J. SCHAWEL & CO.,**

Gold, Silver and Platinum Refiners,

29 JOHN STREET,

NEW YORK.

**SLOAN & COMPANY,**

SUCCEEDING

JOHN A. RILEY & SLOAN CO.,

**MANUFACTURING JEWELERS,**

23 MAIDEN LANE, N. Y.

HAYS BUILDING.

AUGUSTUS K. SLOAN, Pres.

FRANK T. SLOAN, Vice-Pres.

BENNET OSBORN, JR., Treas.

ALLAN A. McDONALD, Sec'y.



**34 YEARS OF  
HONEST RETURNS**

IS OUR GUARANTEE OF SATISFACTION  
TO ALL OUR CUSTOMERS.

WE DO OUR OWN SMELTING,

**JOHN AUSTIN & SON,**

ASSAYERS, REFINERS AND SMELTERS,

74 & 76 Clifford St., Providence, R. I.



PRIZE  
MEDALS  
From  
EXCLUSIVE  
DESIGNS,

for out-door  
Sports.  
Club Pins  
of every  
description.

**HENRY C. HASKELL.**

11 John Street, New York.

Send for estimates.

**DUBOIS WATCH CASE CO.**



**FINE HAND MADE  
SOLID GOLD CASES.**

A PRIDE TO THE MAKER,  
DEALER & WEARER.

**CAMPBELL-METCALF SILVER CO.,  
SILVERSMITHS,**



ALL GOODS 925/1000 FINE.  
Factory, Providence, R. I. Offices, New York and San Francisco

**ROY PHOTO MINIATURES**

GIVE THE BEST RESULTS.

**ROY WATCH CASE CO., 23 MAIDEN LANE, NEW YORK.**

**DIAMONDS** Importers and Cutters. **L. & M. KAHN & CO.,** 172 Broadway, **DIAMONDS** Cor. Maiden Lane, N. Y.



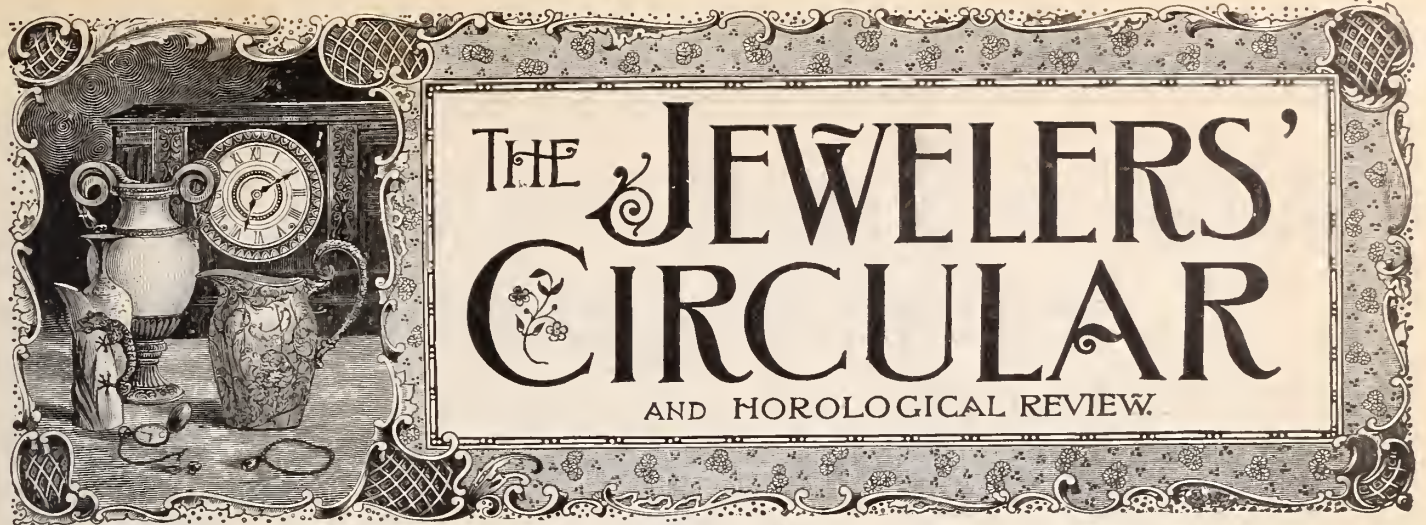

Copyright by THE JEWELERS' CIRCULAR PUB. CO.

189 Broadway, New York.

Entered at the Post Office in N. Y. as second-class matter

VOL. XXXII.

NEW YORK, WEDNESDAY, JULY 8, 1896.

No. 23.

## THE GENESIS AND ARTISTIC DEVELOPMENT OF THE LOVING CUP.

Copyright, 1896, by THE JEWELERS' CIRCULAR PUB. CO.

## PART IV.

It is a natural evolution that the articles of utility made of clay, wood or baser metals prevailing among the common people should be duplicated in the precious metals for the

thus entirely preserved. The lower end of the body is decorated with representations of dolphins which are modeled and applied. The scrolls suggesting water motions are chased and the sea weed decoration is applied. The ornamental detail at the juncture of the handle with the rim represents a spread sailor's Turk's head knot, which is modeled, cast and joined to the handle. The figures of the sailors working the windlass are modeled and applied. Above them are the words and music of the sailors' hoisting song. The cup is not conventional though based upon the ancient tyg.

The *Eagle* cup designed and made by the Alvin Mfg. Co., New York, as a prize presented by the Brooklyn, N. Y., *Eagle*, as a

the Collection of Antique Silver Plate formed by Albert Lord Londesborough," by Frederick W. Fairholt, F. S. A., are illustrated and described a number of silver pieces which the author characterizes as loving cups, they having been used in the manner of the ordinary loving cup. Some of these cups are here presented. They originally did duty at Gorichem in Holland, among societies of cross-bowmen and arquebusiers who met to practise shooting and who had their banquetting hall well furnished with plate. Descriptions of these loving cups are as follows:



THE MONTAUK CUP—A MODERN TYG IN SILVER.

tables of the sovereign and nobles. The tyg, however, is nowhere in authoritative works presented as being made of any precious material. To-day the tyg is commonly followed as the basis of the silver loving cup. Presented on this page are two specimens of the silver loving cup or tyg of to-day. The Montauk cup of the New York Yacht Club belongs to the three-handled variety. It is 10 inches high and its surface is a net-work of fine low chasing and etching. This cup was designed and executed by the Whiting Mfg. Co., New York.

There is practically no base, the handles uniting homogeneously with the bottom and top of the cup. The outline of the body is

trophy in miniature yacht races, is founded on the two-handled tyg of mediæval England. The cup is 10 inches high and has on one side, that shown in the engraving, a large and perfectly modeled eagle with outspread wings, while upon the reverse is etched a picture of a miniature yacht and the inscription, "Brooklyn *Eagle* Perpetual Challenge Trophy for Model Yachts." In the course of this series of articles we will present many specimens of the modern loving cup, founded on its different ancient models.

In "An Illustrated Descriptive Catalogue of



THE EAGLE CUP—A MODERN TYG IN SILVER.

Plate I.—1. A cup, the body formed of a cocoa-nut, elaborately carved with the story of Pyramus and Thisbe. It is richly mounted in silver, the cover of elegant design, surmounted by the figure of a Swiss soldier resting on a two-handed sword.—2 is a cup of silver, chased in high relief with the story

# KENT & STANLEY CO., LTD.,

JEWELERS AND SILVERSMITHS,

SEAMLESS GOLD FILLED CHAINS, JEWELRY,  
SILVER NOVELTIES.

NEW YORK OFFICE,  
21 and 23 Maiden Lane.



BOSTON OFFICE,  
403 Washington Street,

FACTORY, PROVIDENCE, R. I.

## NEW DESIGNS IN ALL LINES.

ALL OUR SILVER GOODS ARE GUARANTEED 925-1000 FINE.

## AJAX INSULATORS.

PATENTED OCTOBER 28, 1889.

THEY are Cheap; THEY Reduce Wear and Tear of the Case;  
THEY Protect from all Ordinary Magnetic Influences

Perfect in  
Action.  
Convenient  
in Use.



MADE IN ALL SIZES, OPEN FACE AND HUNTING  
FOR SALE BY JOBBERS.

MANUFACTURED BY

### The Newark Watch Case Material Co

19 WARD STREET, NEWARK, N. J.

Educate  
Your Customers  
by Talking  
up  
Ajax Watch  
Insulators.

## The Bonner Combination

RING, STUD and SCARF PIN.  
A Long Screw and a Round Bezel.

Send for Selection Package

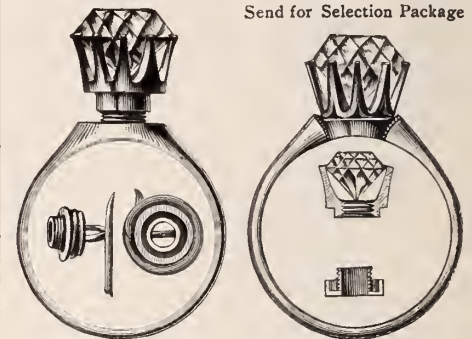

BONNER, RICH & CO.,

41 & 43 Maiden Lane, NEW YORK,  
604 Champlain Building, CHICAGO.

## CROUCH & FITZGERALD.

Jewelry Trunks  
and Cases,

161

Broadway,

Bet. Cortlandt and  
Liberty Sts.,

688 B'way,

701 6th Ave.,

NEW YORK.



## Why We Are Leading Locket Sellers.

Our line is most complete—Styles the very newest—We make lockets of all kinds—Gold Lockets, Gold Filled Lockets, Gold Front Lockets, Platinum and Gold Lockets,



Sterling Silver Lockets. We know all about Lockets—have nothing to think of or talk of but Lockets and similar goods. A large line of fobs, flat and drop seals.



Ask your jobber to show you our new Fall lines.

WIGHTMAN & HOUGH CO., Providence and N. Y.



**V**

Means everything that is first quality in Watch Glasses.

**T**

They are used by more Watch and case makers than all others.

**F**

Their success has induced others to copy the label but not the quality.

## NEW ORNAMENTS

... IN ...

## STERLING SILVER.



Many Designs in

Galleries, Belt Buckles, Belt Slides **AND** Belt Fastenings,

ALWAYS SOMETHING NEW.

THOMAS W. LIND,

Manufacturer of JEWELERS' FINDINGS.

67 Friendship Street,

PROVIDENCE, R. I.



# Standard Sterling Silver Goods.

Belts,

LEATHER, GILT, SILVER AND SILK WEBBING.

Waist Sets,

Sleeve Links, Hat Pins,

IN

Sterling Silver

AND

Rolled Gold Plate.

600 Useful Articles

IN

Sterling Silver.



TRADE MARK REGISTERED.

Foster & Bailey,

Providence, R. I.

NEW YORK, SAMPLES ONLY.

CHICAGO, SAMPLES ONLY.

of the Prodigal; the cover surmounted by a boar. The workmanship of this and the preceding cup is exceedingly fine, and apparently Swiss; No. 3, a cup of silver, dated 1592, embossed and chased. It formed part of the plate once belonging to the company of arquebusiers of Gorichem, in Holland, and is surmounted with a figure of their patron saint, St. George; their arms, two golden crossbows on a blue ground, being enameled in a shield below. The whole of the silverwork and plate belonging to the fraternity was sold by them about 40 years ago and secured by Lord Londesborough for his collection. It comprises the present cup, and one precisely similar; that forming Fig. 4 of Plate I

Plate II.—No. 1 is a great standing cup and cover, silver, elaborately chased, once the property of the fraternity of arquebusiers at Gorichem. It is surmounted by the figure of St. Christopher; and the body of the cup decorated with representations of stag and boar hunting.—No. 2 is a cup of similar design to the preceding, once belonging to the same persons. It is decorated with hunting scenes, bears the date of 1593, and the names of the donors, whose enameled coat of arms hangs

Arnoldo Clevesteymo Jurisconsulto et Exsenatore implorata sacra suprema Themidis ope fortiter Connestebyls in pristinam dignitatem restitutis Fratres sclopetarij unanimiter me strennitatis et infracti animi monumentum inque animi grati testimonium Eternitati consecrarnut ita votum ac tumque est Gorincheni in aede publica Societatis omnibus et singulis presentibus ipsis Calendis Junij anno salutis M. D. C. LXXVI. Insignia horum trium Connestabliorum in operculo meo sunt conspicua." On the lid are the arms of Adriaen Boxel (a cross fleury), Adriaen van Sprang (a tree on a mount), and Arnoldus Clevestijn (ar. on a demi-lion beneath three roses on fess between three trefoils), are chased in relief,

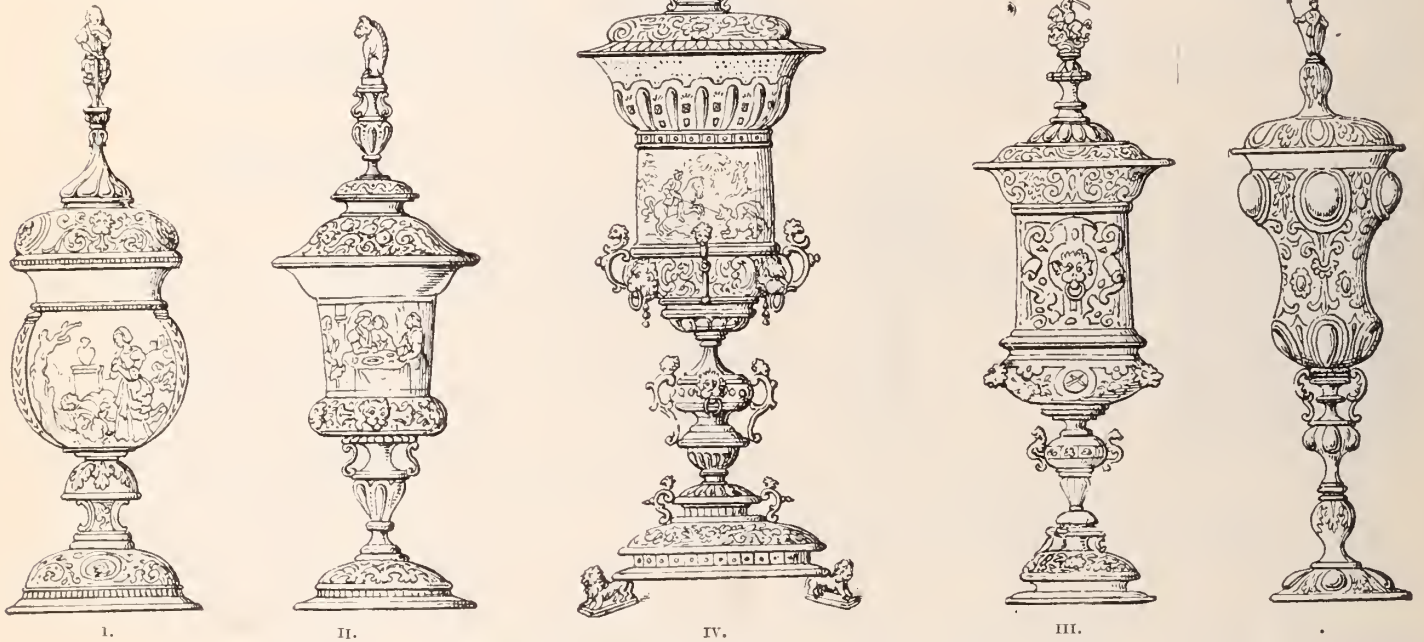

PLATE I.—CONTINENTAL LOVING CUPS IN THE LONDESBOURGH COLLECTION.

and Fig. 5; another, similar to the last, the cups, Figs. 1, 2 and 3 on Plate II, and other works; No. 4 (plate I) is a cup of silver, dated 1603. On the bowl is represented the legendary history of St. George and the Dragon. It bears the mint mark of Amsterdam, and is remarkable for the extreme delicacy and beauty of its workmanship. The lions' heads round the bulb and base hold moveable rings, from which hang gilt pendants. No. 5 is a cup of silver chased with ornament in high relief, and surmounted by the figure of a Roman soldier.

from the lions' heads on the lower part of the body of the cup.—No. 3 is a cup, of silver, the lid having the upper bulb formed of strawberry leaves in open-work; the foliations of the base of the cup are plates applique. The body of the cup is divided by scroll lines into two compartments filled with an inscription, of which the following is a copy: "Calix loquitur. Obvim et injuriam a satrapa Gorinchomiensi superiori Anno ordini et societati sclopetariorum illatam et a presidibus ejus ordinis et Connestabyls Adriano Boxel et Adriano van Sprang Exconsulibus nec non

with their names engraved beneath. This inscription is repeated in Dutch on the other side. On the foot is engraved this distich in the Dutch language, with the author's name, Hubert Brouwer:

"Gekreucht, wiert weer Herstelt door yveren beleydt Dees Eer heeft Boxel, met van Sprangh en Clevesteyn; Het voor-recht van de Schuts. Door Heers sucht of door nyt Van die haer Wap'ne n staen Gedreven op dit Pleyn."

Other cups in the Londesborough collection of the same character as the foregoing are the following. Plate III.—Standing-cup and cover

DORFLINGER'S  
AMERICAN



CUT GLASS.

915 BROADWAY  
36 MURRAY ST.  
NEW YORK.

WATCH

GOLD FILLED.



CASES

A. J. COMRIE,

AUCTIONEER,  
22 John St., N. Y.

SPECIAL SALESMAN OF WATCHES, DIAMONDS,  
BRIC-A-BRAC, FOR ESTABLISHED JEWELERS.

WRITE FOR PARTICULARS.

# TWO NEW PIECES FOR

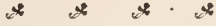

Where would we be if in a quiet season we decided to make **nothing new** till we saw a **demand**?

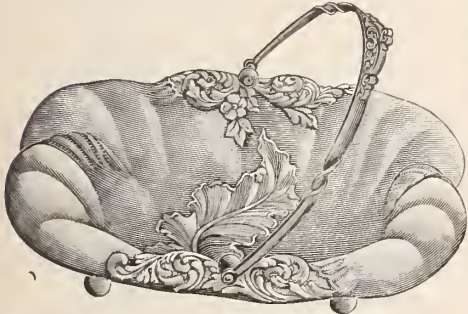

No. 6607. BON-BON DISH.



No. 2846. HAND MIRROR.

# EVERY DAY IN THE YEAR.

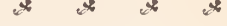

Make the **demand**. Sort up your stock with 25, 50 or 100 new pieces that will make people buy. We furnish goods that sell.



No. 1969. TRINKET TRAY.

FACTORIES,  
NEW BEDFORD, MASS.

SALESROOMS,  
NEW YORK. CHICAGO.  
SAN FRANCISCO. MONTREAL.

## PAIRPOINT MFG. COMPANY.

# CARBORUNDUM

THE GREATEST ABRASIVE YET DISCOVERED.

Four times the Labor and Expense-saving qualities of Emery, Corundum or other abrasives. Adapted for Lapidary Work, Grinding, Polishing and every operation where a perfect abrasive is necessary.

### Price List of Carborundum Wheels.

ACHESON'S PATENT, February 28th, 1893; February 26th, 1895.

DIAM. IN.	THICKNESS IN INCHES.														MAX. REV.		
	1/8	3/16	1/4	5/16	3/8	1	1 1/4	1 1/2	1 3/4	2	2 1/4	2 1/2	2 3/4	3		3 1/2	4
1	\$.15	\$.15	\$.20	\$.20	\$.20	\$.25	\$.30	\$.30	\$.35	\$.40	\$.40	\$.45	\$.50	\$.50	\$.60	\$.70	18000
1 1/2	.20	.25	.25	.25	.30	.30	.35	.40	.40	.45	.50	.55	.55	.60	.70	.75	14000
2	.20	.30	.30	.30	.35	.40	.45	.50	.55	.60	.60	.65	.70	.75	.85	.90	11000
2 1/2	.25	.35	.40	.45	.50	.55	.65	.70	.80	.90	1.00	1.10	1.20	1.25	1.40	1.50	8800
3	.30	.45	.55	.60	.65	.75	.85	1.00	1.15	1.25	1.40	1.50	1.60	1.75	2.00	2.20	7400
3 1/2	.40	.50	.65	.70	.80	1.00	1.15	1.30	1.45	1.65	1.80	1.95	2.10	2.20	2.55	2.90	6300
4	.50	.60	.75	.85	1.00	1.20	1.40	1.60	1.80	2.00	2.20	2.40	2.60	2.80	3.20	3.60	5500
5	.70	.85	.95	1.15	1.25	1.60	1.95	2.30	2.60	3.00	3.30	3.65	3.95	4.25	4.90	5.55	4400
6	.95	1.10	1.30	1.55	1.75	2.20	2.70	3.15	3.60	4.10	4.55	5.00	5.45	5.90	6.80	7.70	3700
7	1.25	1.45	1.65	1.95	2.30	2.95	3.50	4.15	4.80	5.40	6.00	6.60	7.20	7.80	9.00	10.25	3160
8	1.50	1.70	2.00	2.40	2.80	3.60	4.40	5.20	6.00	6.75	7.55	8.30	9.10	9.90	11.45	13.00	2770
9	1.80	2.10	2.40	2.90	3.35	4.30	5.30	6.25	7.25	8.20	9.15	10.10	11.10	12.05	14.00	15.90	2460
10	2.15	2.50	2.85	3.45	4.00	5.15	6.30	7.45	8.60	9.75	10.90	12.00	13.20	14.35	16.60	18.90	2160
12	2.65	3.10	3.70	4.50	5.25	6.80	8.40	9.95	11.50	13.05	14.60	16.20	17.75	19.30	22.45	25.50	1350
14			5.05	6.05	7.00	9.00	11.00	13.00	15.00	16.95	18.95	20.95	22.95	24.90	28.90	32.80	1580
16					9.10	11.70	14.30	16.85	19.95	22.00	24.55	27.15	29.70	32.30	37.40	42.50	1380
18					11.25	14.45	17.70	21.00	24.25	27.50	30.75	34.00	37.25	40.50	47.00	53.50	1230
20						17.50	21.55	25.55	29.60	33.70	37.80	41.90	45.95	50.00	58.00	66.00	1100

Hones, Slabs, Files.

CUT THIS OUT.

The wheels are made with a vitrified bond and pressed under hydraulic pressure. Those over three inches in diameter are turned up after firing. The same numbers are used to designate the degrees of fineness, as are used with Emery, and the wheels are made in seven degrees of hardness, marked SSS, SS, S, M, H, HH, HHH, from extremely soft to extremely hard. In ordering, state diameter, thickness, hole, number and hardness.

## THE CARBORUNDUM CO.

WORKS: MONONGAHELA, PA., AND NIAGARA FALLS, N. Y.

of silver, the largest piece in the entire collection being twenty-six inches in height. It is of much interest as a piece of old English workmanship, bearing the mint marks of a leopard's head, a lion passant, the maker's initials, A. R., in monogram, and the Assay-office letter denoting its manufacture in the year 1613. Plate IV.—Covered cup or hanap, of silver-gilt. Within the lid is the

late president of the Meriden Silver Plate Co. A schedule of the assets and liabilities of said estate was filed, of which the following is a synopsis: Assets—Homestead, No. 861 Broad St., \$16,200; house and lot, 835 Broad St., \$8,000; lot corner Broad and Atkins, \$4,000; lot in Clinton, Conn., \$100; 728 shares Meriden Silver Plate Co., \$18,200; furniture, \$100; note, \$100; total, \$46,700. Liabilities—Mort-

gage running through the residence, could be heard. A body of former employes of Mr. Chase from the Waterbury Mfg. Co. marched to the funeral in a body as a mark of respect. Hundreds were standing about the grounds, and the line reached down the walk to Prospect St., where a considerable body of people had gathered, extending down toward the green, at which place another body of several hundred assembled.

The Rev. Dr. Edmund Rowland of St. John's church read the opening sentences of the Episcopal burial service. A short time after the service the burial took place at the family plot in Riverside cemetery. The honorary pallbearers were the directors of the Waterbury National Bank, Lemman W. Cutler, A. M. Blakesley, Homer Heiminyway, J. M. Burrall, Henry L.

Wade, Nelson J. Welton, James S. Elton and A. H. Scovill. The active bearers were Martin Carroll, Frank McDonnell, John Johnson, Michael J. Keefe and Thomas J. Seerey. The Waterbury National Bank and the Silas Bronson Library were closed this afternoon, and the American counting room from 2 to 4.30 o'clock. Several factories also shut down



PLATE IV.

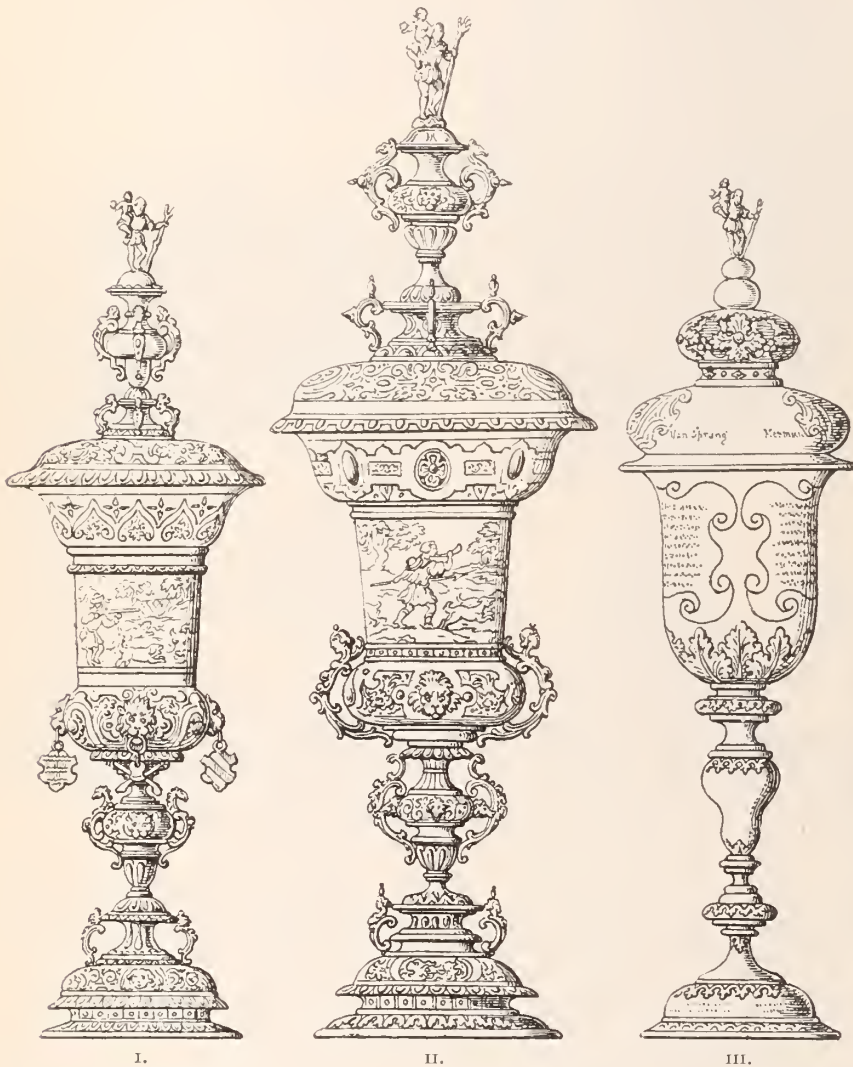

I.

II.

III.

PLATE II.—CONTINENTAL LOVING CUPS IN THE LONDESBOROUGH COLLECTION.

inscription, denoting it as the gift of the magistrates of the city of Hersbroeck, in the Low Countries, to one of the Stanleys during the Thirty Years war. Beneath the foot is a larger inscription to the same effect in the German Language. Plate V. is a globular cup of silver, gilt all over. It is surmounted by a figure of Cupid singeing a butterfly; the ornament on the bowl and cover is double cut and applique. It is apparently of French workmanship, about 1660.

(To be continued.)

#### Schedule of Assets and Liabilities of R. H. Curtis' Estate.

MERIDEN, Conn., July 1.—In the Probate Court this morning Judge Thayer approved the appointment of Benjamin Page as trustee on the insolvent estate of Robert H. Curtis,

gages, \$20,850; notes, \$31,795.09; open accounts, 1,249.21. Total, \$53,894.30.

#### Last Rites to the Memory of Augustus S. Chase.

WATERBURY, Conn., July 2.—The funeral of Augustus S. Chase, late president of the Waterbury Watch Co., who died in Paris on June 7, took place this afternoon at Rose Hill. The services were marked by impressiveness and simplicity. The residence and grounds were thrown open and there was a large gathering, which included associates in many commercial and manufacturing interests, former employes, their wives and children and residents in general. Many were massed on the lawn, from which point the speakers, standing in the south end of the



PLATE V

#### A. B. Griswold & Co.'s New Jewelry Building.

NEW ORLEANS, La., July 2.—A new building, projected for 726 Canal St., is to be occupied by the well known firm of jewelers, A. B. Griswold & Co. They had supervision of the plans, having taken a 10-year lease on the building, and will occupy the four floors, every one of which will be arranged to

suit their views as suitable for a jewelry establishment. The name of the firm will be built in the front walls of the new store, and it will be handsomely decorated and made especially attractive as a place of business. It is somewhat of an innovation for one of the old, long-standing firms to leave the lower side of Canal St. and come to the upper side, but the members of the firm appear elated over the prospects, and believe that they will do even better there than they have in their



PLATE III.

present stand. They say as the building will be larger than their present place, and built with the especial object of a jewelry store, they will be enabled to display their goods to a better advantage. The new place will be fitted up in the most elegant style, and Griswold & Co. hope to show to the public one of the prettiest jewelry stores in the South. They expect to move into their new quarters by Nov. 1.

Frederick F. Bilhoefer was arrested last week on a warrant sworn out by W. U. Watson, jeweler, 457 Main St., Buffalo, N. Y. Watson alleges that Bilhoefer stole from him a lens for testing the eyes. Bilhoefer says he was Watson's partner in business until recently, and that the lens belongs to him.



THIS TRADE MARK MEANS THAT EVERY ARTICLE UPON WHICH IT IS STAMPED, IS **925-1000 PURE SILVER.**

IT ALSO MEANS THAT GOODS SO STAMPED ARE NOT SOLD TO DRY GOODS OR DEPARTMENT STORES, BUT ARE CONFINED TO THE LEGITIMATE JEWELRY TRADE.

NEW YORK,  
CHICAGO,  
SAN FRANCISCO.  
WORKS, PROVIDENCE.

**Gorham Mfg. Co.,**  
SILVERSMITHS.

## OPPENHEIMER BROS. & VEITH,

CUTTERS OF DIAMONDS.

DEALERS IN WATCHES,

65 NASSAU STREET (PRESCOTT BUILDING), NEW YORK.

**E. KIRSTEIN'S SONS CO.,**  
MANUFACTURERS OF  
**Optical Specialties,**  
ROCHESTER, N. Y.

NEW CATALOGUE NEARLY READY.  
SEND US YOUR BUSINESS CARD.

## AMERICAN WATCH CASE CO.,

11 JOHN STREET, NEW YORK.

Manufacturers of **FINE SOLID GOLD CASES.**

**A.W.C.CO**

Sold DIRECT to  
the RETAIL TRADE only.

## TARIFF DECISIONS AND CUSTOMS RULINGS.

Reported from Washington expressly to The Jewelers' Circular.

**Rock Crystal**  
**Dutiable as a**  
**Precious Stone.**

On Sept. 3, 1895, R. C. Hahn imported, through the port of New York, certain merchandise, which was assessed for duty by the Collector of the Port at 30 per centum ad valorem under paragraph 86 of the Act of Aug. 28, 1894, which provides for "All articles composed of earthen or mineral substances, \* \* \* not specially provided for in this Act, \* \* \* if not decorated." This assessment and classification were appealed to the Board of General Appraisers. The specimen of the merchandise which was submitted to the Board was an irregular shaped piece of rock crystal, about 10x12 inches in dimensions and weighing about 20 pounds. From the testimony presented it was proved that rock crystal is classified in trade as precious stone, and the piece in question was unset. It was faced or ground on one side, in order to show the quality of the stone, but was otherwise "unmanufactured." The protest contained four grounds of objection against the Collector's classification of duty, only one of which was considered worthy of note, viz.: that it would more properly have been dutiable under the last clause of paragraph 338 of the same Act as an "uncut precious stone," and, as such, would have been dutiable at 10 per

centum ad valorem. This protest was sustained, and the Collector's decision reversed.

**Duty on Alabaster**  
**Statuary.**

Among the many protests that are constantly being brought to the attention of the Board of General Appraisers, was one entered by Geo. Borgfeldt & Co., relative to the consistency of a decision rendered by the Collector of Customs of the Port of New York, assessing duty on certain statuettes and busts imported by that house on June 27, 1895. The statuettes in question were composed of alabaster, and were assessed for duty under paragraph 105, of the Act of Aug. 28, 1894, as follows: "Manufactures of alabaster, not specially provided for in this Act, 45 per centum ad valorem." The importers did not question the justice of this classification, but their reason for entering protest against same was that at other ports, they claimed similar goods were admitted free of duty. The Board did not coincide with this view and the protest was accordingly over-ruled.

A. H. Ewert has taken the place of manager of the establishment of Sam Moore, Ukiah, Cal., formerly held by Julius Lutke.

## Death of Cyreneus W. Haskins.

NEW BEDFORD, Mass., June 30.—Cyreneus W. Haskins, one of the oldest established and best known jewelers in New Bedford, or, for that matter, in Bristol County, died at his home on County St., Saturday. The whole span of Mr



THE LATE CYRENEUS W. HASKINS.

Haskins' life, up to two years ago, was spent in the jewelry business, and in its pursuance he attained a large measure of success.

Mr. Haskins learned the jewelry trade as a boy with Sylvester Childs, leaving afterwards to enter the employ of Benjamin Dexter, by whom he was later given an interest in the business, the firm style becoming Dexter & Haskins. Subsequently Mr. Dexter died and Mr. Haskins continued on his own account. In his younger days Mr. Haskins was an enthusiastic fireman, and for some years was a member of the Protecting Society. He was an influential and consistent member of the First Christian church and the Sunday school, for a considerable time as superintendent. He was also a member of the Wamshutta club. He was connected with the directorate of several of the Fall River mills, and was interested in many local enterprises. He was a director in various corporations of this city, among them the Citizens' National bank, Bristol Mfg. Co. and city manufacturing corporations. His counsel was always highly prized by his business associates.

About three years ago, Mr. Haskins retired from active business, selling his jewelry store to G. H. Griffen, who in turn sold it to H. S. Francis, who has since been succeeded by L. E. Shurtleff. Mr. Haskins built up the stand till it was known as the leading jewelers' business in the city. He leaves a widow and three daughters.

## A reputation the world over

THE "ROGERS"  
ANCHOR BRAND OF  
SILVER PLATED WARE  
HAS MET ALL COMERS  
FOR THE PAST FIFTY  
YEARS.

IT HAS BEEN PERFECTED WHEREVER THERE HAS BEEN A CHANCE TO BRING IT NEARER TO PERFECTION.

ITS BEAUTIFUL DESIGNS AND ITS THROUGH AND THROUGH QUALITIES HAVE WON FOR IT A GOOD REPUTATION THE WORLD OVER.



"ANCHOR" BRAND

FACTORIES:

Hartford, Conn.    Norwich, Conn.  
Wallingford, Conn.    Taunton, Mass.

WM. ROGERS  
MAN'F'G CO.,

Office and Salesrooms:  
Hartford, Conn.

ESTABLISHED 1849.

INCORPORATED 1890.

J. BRIGGS & SONS CO.,

MANUFACTURERS OF

Gold and Silver Plate and Seamless Wire,

65 CLIFFORD STREET, PROVIDENCE, R. I.

WE MAKE

STOCK FOR

CANE HEADS,  
UMBRELLA MOUNTINGS  
PENCIL-CASES,  
WATCH-CASES,  
WATCH-CROWNS,  
THIMBLES,  
SPECTACLE AND  
EYE-CLASS BOWS,  
DIAMOND MOUNTINGS,  
&c., &c., &c.



**Formation of the National Association of Credit Men.**

The New York Credit Men's Association have issued the following circular letter announcing the organization of the National Association of Credit Men:

GENTLEMEN:—It affords us great pleasure to be able to report the organization of "The National Association of Credit Men," just consummated at Toledo, Ohio. The convention was a most important one, dealing as it did with matters of interest to the commercial industries of this entire country. Representatives were present from all sections of our land, and everyone seemed imbued with a common spirit, that of the improvement of existing conditions, and the reform of abuses now so prevalent. The formation of the association has been effected upon such a broad basis as to commend itself to every merchant. Reforms of importance will now be taken up and pushed with the power of organized force, and although the first year will undoubtedly be devoted to establishing branches and pushing the growth of the association, still work will be commenced at once looking to the protection of credits. Perhaps the very first step that will be taken will be the adoption of a uniform statement blank, which has been conceded as of great importance but which has been impossible heretofore of achievement because of the lack of such an organization.

Our New York association, as the first to be established, was accorded much honor in the convention, and its judgment was sought in the deliberations of the representatives present. It is not too much to say that the effectiveness of this national association and its local branches in all parts of the United States will be more or less dependent upon the New York body. If the judgment of the merchants of this city is favorable as shown by a large membership, it will have a great weight in other cities throughout the country generally.

Such cities as New Orleans, Kansas City and St. Louis have recognized the influence such an association could wield and have organizations numbering one hundred to one hundred and twenty-five members, and certainly in proportion *New York's association should have at least one thousand.*

We invite to membership every individual, firm or corporation in this city extending credit, realizing that as everyone so engaged will reap the benefits from our organization, they should contribute to that end at least the small amount of our annual dues.

Permanent quarters for our local association will be opened as quickly as the membership will warrant, so that members will have a central meeting place for discussion, social intercourse, and where insolvent debtors may meet their New York creditors in a body, for the presentation of such facts as may seem essential.

New York City, by reason of its business interests, must lead in movements of this character, and for that cause we seek the approval of merchants generally in the work which we are undertaking through this movement. Every additional member gives us increased power and effectiveness, and we urge applications for membership from every wholesale industry in this city, not alone upon the ground of self-interest, but because the conditions it is possible to establish through such an organization will augment the welfare of the entire country. Respectfully yours,

THE NEW YORK CREDIT MEN'S ASSOCIATION.  
M. E. Bannin, Pres't.  
H. J. Sayers, Sec'y.

Nathan Cohen, for many years a jeweler of Princeton, Ill., died at his home in Chicago recently. His illness was of short duration, and his end peaceful. He was 62 years of age.

**Executions Against an old New York Retail Jeweler.**

Executions for \$9,772 against Edwin Bennett, retail jeweler, 1294 Broadway near 34th St., New York, were issued to the sheriff Wednesday. They were on two judgments, one for \$6,669 in favor of W. H. H. Childs, and the other for \$3,103 in favor of Julia A. Bennett, both on notes for money loaned. He allowed judgment to be taken against him on these claims. The store was closed when a CIRCULAR reporter called Thursday, and the deputy sheriff in charge was making an inventory of the stock. He said that the goods seized fully covered his executions, but whether or not there was any surplus he could not say. Mr. Bennett was not at the store nor was there anyone to represent him.

Edwin Bennett is one of New York's oldest retail jewelers. He has been in business over 30 years, succeeding Freeman & Bennett, and was generally considered financially sound. He is said to have but few creditors.

**New Standard Watch Order of the Santa Fe R. R. System.**

ST. JOSEPH, Mo., July 2.—The Santa Fé trainmen all over the system are much worked up over the new standard watch order which was recently issued by the officials of the road. The order requires uniformity in watches, which will insure uniformity in time, and thus prevent many accidents. The ques-

tion agitating the men is whether they will be obliged to buy new or certain brands of watches or whether those they now are possessed of will be allowed to be retained.

The circular sent out states that the standard watch must be a 17 jewel movement. However, all watches in the possession of men prior to June 1 of a lower jewel, which on inspection are found to run within the required variation, will be accepted. All watches purchased after June 1 must be 17 jewel, but as all watch companies manufacture that movement, the men may choose any make they desire.

The Waltham watch is recommended by Time Inspector Montgomery from the fact that he has an agreement with the company to replace all watches which fail to run within the required variation. A similar agreement has been made with Dueber-Hampden Co.

A very fine pamphlet entitled "Views Within Our Works" has been issued by the Brown & Sharpe Mfg. Co., makers of machinery and tools, Providence, R. I. Its 32 pages, 9x12 inches, are filled with large and beautiful engravings of interior views of the company's factories, together with a view of their exhibit at the World's Columbian Exposition. The company's object in publishing this book is to recall their works to those who have visited them and to indicate to others the nature and extent of their facilities for satisfactorily manufacturing machine tools, and small tools for machinists' use.

**HERE IS A POINTER.**

*A DEVICE TO HOLD THE NECKTIE DOWN. KEEPS THE TIE FROM SLIPPING UP THE COLLAR.*

**EVERY MAN SHOULD HAVE ONE.**

SOMETHING  
NEW.

◆ ◆ ◆ ◆  
ASK YOUR  
JOBBER TO  
SHOW YOU  
THIS COLLAR  
BUTTON.



**CAPRON & CO., 43 SABIN ST., PROVIDENCE, R. I.**

**DIAMONDS.**  
**Wm. S. Hedges & Co.,**  
 IMPORTERS OF  
 Diamonds and Precious Stones.  
**DIAMOND JEWELRY.**  
 170 Broadway, New York.  
 22 Holborn Viaduct, London.

**Alfred H. Smith & Co.,**  
 IMPORTERS  
**DIAMONDS**  
 AND  
**PRECIOUS STONES,**

182 BROADWAY, COR. JOHN STREET,  
 NEW YORK.  
 Venetian Building. 34 & 36 Washington St  
 CHICAGO, ILL.

**BATES & BACON**  
 "FAVORITE"  
 14K

**BATES & BACON**  
 "ROYAL"  
 14K

**BATES & BACON**  
 "PURITAN"  
 14K

**ALWAYS**  
 Ask to see  
 our  
**GOLD FILLED**  
 WATCH CASES.  
 None Better  
 and  
 Few Equal.

**HERMAN KOHLBUSCH, SR.**



Established 1859  
 Manufacturer of  
**FINE BALANCES**  
 AND WEIGHTS for  
 every purpose  
 where accuracy is  
 required. 59 Nassau  
 Street, cor.  
 Maiden Ln. N. Y.



Repairs (any make)  
 promptly made

**SCHULZ & RUDOLPH,**  
 IMPORTERS AND CUTTERS OF  
**DIAMONDS** AND OTHER **PRECIOUS STONES,**

(Successors to JOHN E. HYDE'S SONS.)  
 Sole Agents for **The Celebrated Jules Jurgensen Watches.**  
 28 JOHN ST. and 65 NASSAU ST., NEW YORK.

# The Bowden Rings

ARE COMPLETE IN VARIETY, CORRECT  
 IN QUALITY AND PERFECT IN FINISH.  
 WE MAKE EVERY VARIETY OF FINGER  
 RINGS

**J. B. BOWDEN & Co.,**  
 3 MAIDEN LANE, NEW YORK.

## Classes of Goods in Demand at Various Points.

### BELTS, PINS AND BUTT NS HAVE THE CALL IN PROVIDENCE, R. I.

PROVIDENCE, R. I., June 30.—Belts in all styles continue among all the leading sales, although pins, buttons and other novelties suggestive of sports and the seashore find ready sale. The bicycle designs lead, closely followed by yachting. Class pins and emblems have been much sought after the past week in supplying graduates from the several schools and institutions at commencement.

The manufacturers of campaign goods are just booming now and barrelsful of these trinkets are being shipped daily. It is the makers of the cheaper lines who are the busiest although such firms as are making the finer grades find enough to run their factories full time and capacity.

### SUMMER GOODS MOVE IN PHILADELPHIA, PA.

PHILADELPHIA, Pa., June 29.—There has been a spirited demand for various articles of silverware during the past week. The approach of July brought an increase in the sale of blouse sets, belts, and other articles for Summer wear, and as a whole, the week ended with better results than were noticeable during the preceding week. The same conditions existed among opticians, where there was a brisk but brief demand for certain kinds of goods, including thermometers and an ordinary grade of eye-glasses.

### LEATHER BELTS, COMBINATION PINS AND SUMMER JEWELRY IN ELMIRA, N. Y.

ELMIRA, N. Y., June 30.—Leather belts are very popular and largely in demand. A necessary accessory to this article is the combination pin and skirt holder, which comes in beautiful designs of silver. Satisfactory sales are reported in blouse sets, both in gold and silver. There are also a great many silver bicycle equipments that are very popular among the lady cyclists.

There has been an effort to introduce what is known as Summer jewelry. This comes in various articles, all silver, and the several pieces represent the different Summer sports. Jewelers are still advertising cut glass and heavy silver pieces.

### NOVELTIES HAVE THE CALL IN CINCINNATI.

CINCINNATI, O., July 1.—One of the latest novelties in silver for table decoration which is having a ready sale is the fruit dish and flower holder combined. One of the prettiest and most unique is a round dish in elaborate floral design, surrounded by five horns of plenty. When the dish is heaped with fruit and the horns filled with flowers the effect is beautiful.

Some of the jewelers are having sales on a small but very ingenious article called the "Monopress," consisting of two strips of celluloid in which are two fancy initials. With it anyone can emboss his or her own stationery. Opals and diamonds are dividing interest in

the sales of gems in Cincinnati. Butterfly veil pins are in demand, from the baby butterfly scarcely as big as a pea to great ones that hover in the garden. The colors are as vivid as the real ones, while some are made entirely of pearls.

Several of the jewelers report that the sale of watches has revived.

**SILVERWARE IN FIRST DEMAND IN SYRACUSE, N. Y.**

SYRACUSE, N. Y., July 2.—Syracuse jewelers report an unusually large call for silver, with tableware first and silver novelties second. June weddings have been productive of a good call for silver tea sets. Watches are slow.

**SILVER GOODS AND LADIES' BRACELETS IN SAN FRANCISCO.**

SAN FRANCISCO, Cal., June 25.—A. I. Hall & Co. report present sales mainly in silver goods and ladies' bracelets. Carran & Green have been selling mainly silver novelties and leather belts. Rothschild & Hadenfeldt report silver novelties in first demand. Andrews' Diamond Palace is selling watches and diamonds; W. K. Vanderslice & Co., small jewelry and silver novelties.

**Mortgage Claim Against the Columbus Watch Co. Allowed.**

COLUMBUS, O., July 2.—Receiver Bruck, of the Columbus Watch Co., has been ordered by Judge Badger to allow the \$6,000 mortgage bond claim of the State Savings Bank and Trust Co. against the property of the defunct watch company in full (\$6,000) and pay dividends on it as a general claim. The trust company advanced the watch company \$6,000, taking as security six \$1,000 bonds secured by mortgage on real estate and the note of the company for the full amount. The property was sold, but failed to bring more than \$2,000 and now the claim will be treated as a general one.

**The Liabilities and Assets of Breckbill & Benedict.**

BRIDGEPORT, Conn., July 1.—The list of the debtors of the insolvent estate of Breckbill & Benedict, with a schedule of assets, was filed in the Probate Court to-day. There are 70 names on the debtor list, and the amount totals about \$10,000. The assets are only \$8,509.59, as follows: Stock and general merchandise, \$6,359.61; tools and machinery, \$600; fixtures, \$1,049.98; book accounts, \$509. The assets of the personal estate of Frank Benedict, a member of the insolvent firm, were filed also, as follows: House, lot and furniture, valued at \$5,500. Fred Breckbill has no personal estate. The firm are doing business continuously.

Patrick Coughlin has been appointed trustee of the estate and the appraisers are Charles H. Davis and E. W. Button.

It is said that every time the clock ticks a baby is born into the world. People who have had triplets want to stop the clock.—New Orleans *Picayune*.

ESTABLISHED 1840.

**RANDEL, BAREMORE & BILLINGS**

IMPORTERS OF

**DIAMONDS,**

AND OTHER PRECIOUS STONES.

**FINE PEARLS A SPECIALTY.**

MANUFACTURERS OF

**DIAMOND JEWELRY**

A Large Stock of Fine Mounted Goods Constantly on Hand.  
Goods Sent on Approval and Insured in Transit.

Diamonds Cut, Recut and Repaired.

58 Nassau Street,  
29 Maiden Lane,  
NEW YORK.

1 Tulp Straat,  
AMSTERDAM.

1 St. Andrew's St.,  
Holborn Circus,  
LONDON E. C.

ESTABLISHED 1841.



**CARTER, HASTINGS & HOWE,**

MANUFACTURERS OF

**GOLD JEWELRY,**

**15 MAIDEN LANE, NEW YORK.**

A. CARTER

C. E. HASTINGS,  
W. T. CARTER,

G. R. HOWE,  
W. T. COUCH,

FACTORY, NEWARK, N. J.

**WOOD & HUGHES,**  
**STERLING SILVERWARE MANUFACTURERS**  
New York Agents for the Derby Silver Co.,  
**FINE QUADRUPLE PLATED WARE**  
No. 16 JOHN STREET, NEW YORK  
206 Kearney St., San Francisco, Cal.  
**HASKELL & MUEGGE, Agents.**

**FERD. FUCHS & BROS.**  
**SILVERSMITHS.**  
MAKERS OF STERLING SILVERWARE,  
808-810 Greenwich St., - New York.

**Consolidation of the New York Jewelers' Board of Trade and the Jewelers' Mercantile Agency.**

The final contract which practically consolidates the New York Jewelers' Board of Trade and the Jewelers' Mercantile Agency, Ltd., was signed Friday morning. By this agreement the Board of Trade leases the business and reference book of the Mercantile Agency at a stipulated sum per annum for a period of 10 years, at the end of which time, if the contract be carried out, the reference book becomes the property of the Board of Trade. De Loid Safford, president of the Jewelers' Mercantile Agency, will continue as heretofore to get out the reference book, which now appears in its usual form except that under its title are the words "New York Jewelers' Board of Trade, Lessees."

All the existing contracts of the Jewelers' Mercantile Agency will be carried out, but after their expiration the reference book will be supplied only to members of the Board of Trade. After Jan. 1, 1897, the annual dues of the Board of Trade will be raised from \$90 to \$125 and all members will be supplied with a reference book. Until January members of the Board have the privilege of obtaining the July book, the first to be issued under the contract, on the payment of \$35.

The two organizations will soon be brought under one roof and a committee to take charge of this part of the proceedings has been appointed. It is believed that the quarters into which both concerns will be brought are those now occupied by the Jewelers' Mercantile Agency, 214 Broadway. The report and the inquiry departments of both the Board of Trade and Mercantile Agency will be combined and the inquiry department as well as the reference book will be under the personal control of De Loid Safford.

The following firms were elected members of the New York Jewelers' Board of Trade at the last meeting of the directors: Henry Freund & Bro., 5 Maiden Lane, New York; A. Wittnauer, 19 Maiden Lane, New York; Rees, Zimmern & Rees, 65 Nassau St., New York; Wendell & Co., New York and Chicago.

**Proceedings of the Jewelers' League.**

The regular monthly meeting of the executive committee of the Jewelers' League was held on July 1st. There were present: Vice-Presidents Bowden, Bardel and Greason, Chairman Van Deventer, Messrs. Beacham, Smith, Street, Karsch and Fessenden and L. Stevens, secretary. The minutes of the previous meeting were read and approved. Two requests for change of beneficiary were received and upon motion granted. The following applicants were admitted to membership:

*Sec. A.* Henry J. Fink, New York, recommended by L. Stevens, Jr., and F. T. Oertel; John F. Garland, Louisville, Ky., by S. Heymann and F. M. Welch; Thos. J. Juzek, Elgin, Ill., by P. S. Bartlett and W. H. Cloudman; Ike Lavenson, Philadelphia, Pa., by M. Herzberg and A. Herzberg; Jas. J. Meyer,

Matteawan, N. Y., by F. L. Howard and L. Stevens, Jr.

*Sec. B.* Wm. A. Larrabee, Providence, R. I., recommended by H. C. Tilden and H. Tilden.

The last death in the League occurred on April 26, 1896. The beneficiary has been paid and the League does not owe one dollar at this date. The next meeting of the executive committee will be held on Aug. 7, 1896.

**George H. Crumb Killed While Bicycling.**

CLEVELAND, O., July 3.—One of the saddest accidents which has ever happened in Cleveland occurred Wednesday morning while George H. Crumb, the secretary and treasurer of the Bowler & Burdick Co., was riding his bicycle to the city. He was riding with a friend on Prospect St., upon which thoroughfare the Euclid and Wade Park Ave. car lines operate. As the bicyclers approached Fern Alley, a paved street extending from Prospect St. to Euclid Ave., his friend suggested taking that route to reach the city by way of Euclid Ave. He was unable to make the turn into the course and turned toward the left to make a circle. Just as Mr. Crumb turned onto the car track a rapidly moving car struck him and in a moment he was under it and was carried a number of feet before the car could be brought to a standstill. He was then found to be wedged beneath the gearing.

It was necessary to lift the car from the rails in order to release Mr. Crumb. He was unconscious and was removed to the Charity Hospital. There it was found that two ribs and the collar bone were fractured in addition to which Mr. Crumb was terribly cut about the head and injured internally. Two hours after his arrival at the hospital he died, having failed to regain consciousness. His wife was at the bedside when he passed away.

Mr. Crumb was one of the best known business men in the city, and had a host of friends. He was the son of C. A. Crumb, who for years was engaged in the brokerage business under the firm name of Crumb & Baslington. He was 36 years old and is survived by a widow and three children. He had been secretary and treasurer of the Bowler & Burdick Co. for six years, having been with that company for eight years. In addition he was connected with the Knights Templar and Shriners and was treasurer of the Royal Arcanum and Kirk's Military Band. The news of his death was a great shock to his friends and among his business associates his untimely end is spoken of with deep regret. Owing to the absence of the senior member of the firm, R. E. Burdick, the position made vacant by Mr. Crumb's death will be filled by Justin Snow.

**Anthony Kaiser at Last Succeeds in "Fooling the Patrolman."**

DETROIT, Mich., July 4.—Anthony Kaiser, a well known jeweler here, 32 years of age, committed suicide yesterday at mid-night by jumping into the Detroit river. Shortly before that hour he remarked to Patrolman Carmichael that he would fool them yet. The policeman found his clothes on the dock. The body has been recovered.

Kaiser was for many years in the jewelry business with his father at 213 Gratiot Ave., but recently the old gentleman became too old to manage the business and it was disposed of. Since then Kaiser has been idle. He was given somewhat to drink, and was under the influence of liquor at the time of his death. He had a habit of undressing himself and going to sleep in the most unseemly places.

**Wore the Diamond in His Leg.**

GUS FOX tells a story to the Cincinnati *Enquirer* about the famous Orloff diamond, named after Count Orloff, the first European who bought it. Fox says: "It was originally the eye of an idol in Trichinopoli. It was stolen according to the accepted account, by a Frenchman, who escaped with it to Persia, where he sold it for an equivalent in our money of \$8,000 to a Jewish merchant.

"The Jewish merchant sold it to an Armenian named Shafras, who had traveled in Russia, and conceived the idea of taking the diamond to that country and selling it to the Empress Catherine for a great sum. Shafras paid him \$60,000 for it.

"Having secured the stone, the next question with Shafras was how to get it to Russia, or rather how to conceal it when he was searched by robbers, as he was sure to be on the road. The journey was a long and perilous one, and thieves abounded everywhere. Shafras thought of swallowing the stone when he should be taken by the robbers, but was obliged to give that plan up, as the diamond was too large to swallow.

"He began to feel he had a white elephant on his hands, when a thought occurred to him. He procured a sharp lance, made a cut in the fleshy part of his left leg, and thrust the diamond into the wound. He sewed up the cut with a needle and a silver wire. It healed, leaving the diamond embedded fast in the leg, quite out of sight.

"Then he started for Russia. On the way he was seized by robbers again and again, and was thoroughly searched. Being an Armenian, and suspected of going to Russia to trade, the thieves marveled greatly at finding nothing of value upon his person.

"He arrived in Russia at last, and, after extracting his diamond, visited the Empress. He was willing to sell it for about \$150,000, but the Empress had not so large an amount in cash for the purchase, and Shafras preferred to go on to Amsterdam, the seat of the diamond cutting industry, where he had the stone polished.

"Here Count Orloff, an extremely wealthy Russian, saw the diamond, and was filled with a determination to secure it for the Russian crown. He did secure it, but Shafras exacted from the Russian Government \$400,000, an annuity of \$20,000, and a title of nobility. He died a millionaire.

"The Orloff diamond weighs 195 carats, and is about the size of a pigeon's egg. It is smaller than the Koh-i-Noor, in the possession of the English Queen, which is supposed to be worth \$3,750,000."

## Men, Women and Watches.

(CHARLES DUDLEY WARNER IN HARPER'S MAGAZINE.)

A man gets great pleasure out of a good watch. It is a most beautiful piece of mechanism. It is an ornament and a companion. He becomes attached to it for its individual qualities and excellences. Every watch has a character of its own—that is, every good watch that has any character at all; for it must be confessed that the great majority of watches of the trade have not so much distinct character as the majority of men and women. Even the excellent watches made by machinery, with interchangeable parts, are not alike. A fine watch is a sensitive thing; it needs a good master, who appreciates it, and partakes of its own system of regularity; and it is sensitive to the weather, to change of position, and, I sometimes think, to the personal temperament of the one who carries it. This is the reason why women and watches seldom get on well together. I doubt if a fine watch has those feminine qualities which make women so attractive. The watch is nothing if it is not methodical and regular. It is exasperated by fitful and jerky treatment. And this quality of steadfastness makes it not loved of women as men love it. They like it as an ornament, as a decoration, like the ring and the brooch, and it is sometimes a convenience in order to tell them about (not exactly) what time it is. Women do not, as a rule, except in cases of entire emancipation, care what time it is exactly. They can go without a watch with no sense of incompleteness in their lives, whereas a man feels lost without his faithful time-keeper.

This relation of woman to the watch needs to be seriously considered for the light it may throw not only upon the differentiation of the sexes, but upon their adaptation for keeping this world going in its various functions. It is possible that here is a kind of touchstone which can be applied. For instance, if a woman finds that she has the same feeling toward a watch that a man has, is she not justified in concluding that she has the qualities needed for success in what are still called masculine occupations? And in trying to bring about the reform—that is, the complete emancipation (the word is an awkward one, but it is used here because it has the syllable "man" in it) should not the first effort be to put the sex into proper relations with the watch? There is evidently a great truth here somewhere, and the topic is worthy of an essay, but that would lead me quite away from the present intentions of this paper.

I am trying to convey a definite idea of the enjoyment a man has in his watch. It is an object pleasing to him in itself, but his regard for it depends upon the perfection of its mechanism and its exact performance. No Roman probably ever had the same feeling in regard to his clepsydra—the ingenious water device for teaching the great fact that De Quincey dwells upon, the fact that there is no

present, only a past and a future, since the most infinitesimal division of the coming and going drop of water could never hit the atom that was not just disappearing or had not yet arrived. The Roman could have no personal attachment to such a piece of philosophical or laboratory apparatus. It is no doubt the exactness of the watch as a timekeeper that pleases a man and adds to his egotism as an owner of it. He is jealous of its reputation. He resents criticism of it. Nothing sooner raises heat in the male mind than a comparison of another man's watch unfavorable to his. He trusts his tried machine. He has infinite satisfaction in knowing that he has the exact time. Nothing more upsets him and lowers his self-esteem than to have a favorite watch go back on him. To lose confidence in it is somehow to suffer a fundamental shock in the general integrity of things.

But I will not emphasize this aspect of the subject. What I speak of here is the man's enjoyment of his watch, which depends upon its quality, and is quite independent of the delight of a savage in a "ticker," or of the small boy in the coarse machine whose winding up is as much a labor as the walking round a capstan on shipboard to raise an anchor. Thanks to the number of good watches made, this is a common enjoyment. And the singular and significant fact about this happiness is that multitudes are content to experience it without any desire to make a watch. Very few people think that because they have this capacity to enjoy a watch, they therefore are under an obligation to go into the business of watch making, and impose their crude machines upon the public. It requires, all admit, skill and peculiar gifts and long apprenticeship to produce a fine watch, and, by common consent, we go to a watch maker when we desire a good timepiece. The capacity to enjoy is no certain sign of the ability to produce. To be sure, the world is full of what might be called syndicate work in the way of watches, machine made, to sell, not to be exact, or to last long, and not to give much satisfaction. A plea can be made for this sort of mediocrity that a poor watch is better than none, and so forth. I am aware that a plausible argument can be made for the university extension of cheap and inaccurate watches. But to make this or to refute it will again lead me astray

from my subject. The subject is simply this—that a man may enjoy a fine watch and yet have no responsibility on him to try to make one.

## Witty Local Notices.

A GOOD form of advertising is that with which jeweler W. E. Cross, Amsterdam, N. Y., is favored by the local newspapers. This advertising consists of reports of fictitious incidents occurring in this store, which contain elements of humor. These incidents are founded upon more or less ancient jokes which, however, do not seem to have yet reached the inhabitants of Amsterdam. The following which appeared in the *Daily Democrat* of May 21st, is an example:

A citizen took his watch to Jeweler W. E. Cross to-day and asked the reason of its stopping. "Well," said Cross, "there's a bedbug in it." "Why, how could a bedbug get in a watch?" "Easily enough," replied the witty jeweler; "it went in between the ticks."

This joke seemed to possess so much vitality that it was repeated in the issue of June 3rd, in the same paper, as follows:

A fellow entered Jeweler Cross' establishment yesterday, and, announcing that he wished to purchase a clock for his bedroom, was shown several time pieces. Finally he selected one and had it delivered at his residence. This morning he came down town with it and stated to Mr. Cross that it wouldn't do, as it ticked too loudly. "Why don't you sleep between the ticks," was the timely reply of the witty man who "pushes the button and allows the whistle to do the rest."

The humor that exists between bed bugs, ticks and watches was appreciated by the ancient Medes and Persians—only the ancient Medes and Persians did not have watches, though they undoubtedly had the bugs.

Mr. Cross writes that these notices are not paid locals and that the one first quoted was the best of all, caused a great deal of comment, and proved a very good advertisement. We do not see why other jewelers cannot accept Mr. Cross' mode of advertising. The items are very good reading matter to the public and establish a reputation for humor and wit for the jeweler which is apt to prove advantageous.

## A. WITTNAUER,

SUCCESSOR TO

J. EUGENE ROBERT & CO.,

IMPORTER AND MANUFACTURER OF  
PLAIN AND COMPLICATED

WATCHES AND  
WATCH MOVEMENTS,  
19 Maiden Lane, New York.

THE SIMPLEST STRONGEST  
AND BEST  
**SKIRT SUPPORTER**  
MADE.



Twin Hooks Hold Shirt Waist  
and Skirt Immovably.

MADE OF A SOLID PIECE OF STERLING  
SILVER WITHOUT SOLDER.

Prices to the Trade in Plain Sterling.

1 in. \$5.00 per doz.	1½ in. \$7.00 per doz.
1¼ in. 6.00 " "	2 in. 8.00 " "

Rose Gilding, \$2.00 per dozen Extra.

Made in plain Sterling, Sterling Gilt and 14K  
Gold, of Heavy Weight, Only.

A VARIETY OF PATTERNS.

**THE TENNANT CO.,**  
SILVERSMITHS,  
33 Union Square, N. Y.



**YOUR WINDOW DISPLAY.**

Is it as attractive as it might be? One or two  
Rogers Statuettes will add greatly to its interest.  
Send for beautiful Catalogue. Above depicted  
group, lists at \$8.00 only.

**ROGERS STATUETTE CO.,**  
441 PEARL STREET, N. Y.

**News Gleanings.**

H. N. Price, Chanute, Kan., has given a  
chattel mortgage for \$800.

C. B. Griffin, San Diego, Cal., has sold out  
his jewelry store.

D. T. McCulloch, Wilmington, N. C., has  
removed to 25 S. Front St.

H. Franklin, Beeville, Tex., is selling out  
his stock of jewelry at auction.

John E. Payne, Guilford, Mo., recently  
filled a chattel mortgage.

O. C. Moore has opened a new jewelry store  
in Orient, Ia.

E. F. Smith is preparing to go out of the  
jewelry business in Suisun, Cal.

E. B. Nan Ness, Mound City, Kan., has  
disposed of real estate valued at \$300.

W. A. Bowes has moved his jewelry store  
from Miller, S. Dak., to Faulkton, S. Dak.

J. E. Conley has given a bill of sale of  
his jewelry store in Nebraska City, Neb., for  
\$2,000.

D. Rust has succeeded to the drug and  
jewelry business of Rust & Manley, Whiting,  
Ia.

Leopold Kabie has moved his jewelry store  
from Cheyenne, Wyo., to Colorado Springs,  
Col.

Peterson & Davidson have succeeded to the  
jewelry business of M. Peterson, Eldorado  
Springs, Mo.

Charles L. Dinger, Chester, Pa., has started  
on a business trip to Chicago, Milwaukee and  
Laporte, Ind.

A thief a few nights ago carried off the  
small stock of A. P. Wilder, Eau Claire, Wis.,  
leaving the jeweler penniless.

W. R. Stidham, Commerce, Tex., dealer in  
drugs and jewelry, has filed a trust deed  
making H. C. Barker trustee, with preferred  
creditors.

Bennett & Guyselman, Urbana, O., are sell-  
ing their stock at auction to close their part-  
nership, which ends by contract. P. R. Ben-  
nett, Jr., will retire, and C. F. Guyselman  
will continue the business in the same room.

Chas. Bornemann, manufacturing jeweler,  
Jersey City, was robbed of a valuable dia-  
mond pin Thursday while riding in a street  
car. Mr. Bornemann is the inventor of a  
safety guard catch for pins which he did not  
wear.

W. O. Blase, jeweler, Wilkesbarre, Pa., has  
on exhibition in the windows of his store a  
bridle and hunting bag, at one time owned by  
the noted Indian chief, Sitting Bull, and also  
a pistol presented to Texas Harry, by the no-  
torious bandits, Frank and Jesse James.

On July 1st, Murray C. Leinbach, of Antes  
Fort, Pa., took charge of the Keystone Jewelry  
Store, Lock Haven, Pa. J. B. Rosser, who  
has had charge of the store since last Spring,

will go to Adams county, where he will start  
in business for himself.

W. F. Main and family, Iowa City, Ia., left,  
July 1, for Providence, R. I.

Charles E. Simonton, Washington, N. J.,  
has sold out to D. W. Drake.

Wood & Darling, Haverhill, Mass., have  
dissolved partnership, and Henry Wood, of  
the firm, continues.

Philip H. Young, jeweler, Dodge City, Kan.,  
was united in marriage July 2 with Miss Flor-  
ence McMichael at Kinsley, Kan. The couple  
will be at home in Dodge City after Aug. 15.

Murray M. Henry, McKeesport, Pa., bade  
his family goodbye Monday morning, June 22,  
visited his shop on Sinclair St., then disap-  
peared. He is 28 years of age and well known  
in the city. He has been talking of going to  
Cuba or South America of late.

J. H. Leyson, Butte, Mon., has manufac-  
tured a gavel for the Chicago Democratic con-  
vention, of 16 parts silver to one of gold.  
The expense was met by a popular subscrip-  
tion of the people of Butte, no one being al-  
lowed to give more than 50 cents.

The jewelers of Waterloo, Ia., have pub-  
lished a card agreeing to close their places of  
business at 7:30 o'clock p. m., except Satur-  
day evenings, and evenings of Illinois Central  
pay days. The arrangement went into effect  
June 22, and continues until Nov. 15.

The Massachusetts Year Clock Co., Port-  
land, Me., have incorporated for the purpose  
of manufacturing and selling clocks, with  
\$250,000 capital stock, of which \$300 is paid  
in. The officers are: President, Anson C.  
Barnes, Wakefield, Mass.; treasurer, Charles  
A. Firth, Wakefield, Mass.

The following jewelers of Middletown, N.  
Y., will close from July 7th to September 25th,  
inclusive, at 6 o'clock p. m., Mondays and Sat-  
urdays excepted; D. C. Dusenberry & Son, C.  
J. Giering, F. D. Kernochan, A. M. Ambler,  
B. F. Gordon, J. W. Preston, H. S. Dusen-  
berry & Son, Chas. L. Swezy.

An attempt was made to rob the jewelry  
store of H. C. Held, Grand Island, Neb., a  
few nights ago. The burglars cut the panel  
out of the back door and gained admittance  
to the back room of the store, but the par-  
tition door was locked and they gave up the  
job and departed without securing any valu-  
ables.

A few days ago some boys found eight  
battered and broken watches at Locust  
Mountain, Mt. Carmel, Pa. They were  
identified as part of the stock  
stolen from Max Dorewicz's store some  
four weeks ago. It was reported that about  
60 watches were stolen at the time.  
Mr. Dorewicz has already given 35 per-  
sons, whose timepieces were stolen from his  
store, other watches in their place.

**RAZZLE RINGS**  
**POZZLE**  
MADE BY HENRY C. HASKELL, N. Y.

HENRY C. HASKELL,  
11 John St., New York.

Send  
For  
New  
Price  
List.

**FINE CASES . . . . .**

for Jewelry, Silverware, etc.  
Hardwood Chests, Trays and  
sample cases. Business estab-  
lished in 1876.

Samuel C. Jackson's Son, 180 B'way, N. Y.

D. K. Talbot, Ladd, Ill., has assigned.

A. E. Marcher, Los Angeles, Cal., has given a realty mortgage for \$900.

Philip O. Alley, Port Jefferson, N. Y., has gone out of business.

The store of D. W. Prentice, Whitney, Tex., was burnt out lately.

Frank P. Mooney, Salem, Mass., has given a chattel mortgage for \$1,000.

Leonard Krower & Co., New Orleans, La., have dissolved partnership; Leonard Krower succeeds to the business.

Burdette C. Barnes, formerly of the Kasper & Barnes, is now associated with Rowe Bros., corner State and Monroe Sts., Chicago.

The Knickerbocker Silver Co. are removing their factory from New York city to their newly purchased property in Port Jervis, N. Y.

Louisa A. Wood, jewelry, Washington Ave., Detroit, Mich., July 2, filed nine chattel mortgages amounting to \$1,900, in favor of creditors.

Charles C. Mussina, Williamsport, Pa., is making some fine improvements in his jewelry store. He has dropped the windows down to a nice position, and the tops are ornamented with cathedral glass.

The jewelers of Norristown, Pa., decided to close their respective places of business on July 4th; also every evening at 6 o'clock (Mondays and Saturdays excepted) commencing July 7th, and ending Sept. 15th.

Charles H. Rice, jeweler, Bennington, Vt., is a victim of the bicycle. While returning from a ride to North Bennington he collided with a team. His shoulder struck the wagon, breaking his collar bone. Mr. Rice is able to be around his store, but is carrying his arm in a sling.

Andrew J. Anderson died in Elgin, Ill., recently. For many years he was employed at the watch factory in Rockford, and when that institution began to lay off its help he opened a jewelry store on E. State St. He was engaged in this business some time. Deceased was 47 years old.

About 10 minutes before 10 o'clock on the evening of July 1, the jewelry store of Mr. Perkins, at the corner of Main and Bank Sts., St. Albans, Vt., was entered by a burglar and between \$75 and \$100 worth of jewelry consisting largely of diamond settings, etc., was taken. The thief entered through a very small opening in the window on the back side of the store while the night clerk, who sleeps in the store, had stepped out for a few minutes after the store was closed for the night.

The marriage of Arthur Wood Kennard, of Boston, and Miss Helen Lucy Stebbings, of Cazenovia, N. Y., was solemnized June 30, at St. Peter's Episcopal church in Cazenovia. It was one of the most elaborate and largely attended events of the kind that has recently taken place in central New York. The bride is a member of one of the very oldest and most aristocratic families of Cazenovia, being a daughter of the late John Stebbings, a granddaughter of the late Sidney T. Fairchild, and a niece of ex-Secretary of the Treasury, Charles S. Fairchild. The groom is a son of the late member of that name of Bigelow, Kennard & Co., jewelers, Boston.

## New Jewelry Businesses.

Geo. Miller, Auburn, Cal.

Chas. S. Carnes, Healdsburg, Cal.

A. J. Potter, Baden, Cal.

Wm. B. Joseph, Catskill, N. Y.

D. G. Fischel, Green Island, N. Y.

Wm. F. Sellers, 1115 Eleventh Ave., Altoona, Pa., on Aug. 1st.

MacMillan & Beyer, Schenectady, N. Y., have leased a vacant store in the Kline row at the corner of Market and Division St., Amsterdam, N. Y., and will open a jewelry store in a few days.

## The "Indiana" Silver Service.

IN their establishment on Union Square, New York, Tiffany & Co. have placed on exhibition the beautiful silver service which they have just completed for the battleship *Indiana*, and Monday afternoon tendered a private view of it to the press. The service, with the massive oak bound chests, makes a brilliant display. The whole service is of sterling silver, 925-1000 fine, and consists of about 40 pieces. Almost all the pieces are large ones, as experience has demonstrated that forks and spoons and other similar small objects, when used aboard ship, develop an incurable tendency to disappear; and as no part of the money appropriated was diverted for the purchase of the ordinary individual pieces, the generous fund enabled Tiffany & Co. to give the fullest play to their artistic abilities.

The keynote of the artistic and graceful decorations is the beautiful centerpiece. This superb piece is a large flower or fruit dish, measuring 28 inches, and about 10 inches in height. Its graceful rolling form suggests the rolling swell of the sea; but, while giving due recognition to the nautical claims of the subject, any tendency to overburden this beautiful and costly service with purely nautical subjects has been studiously avoided. In the center, on either side of the centerpiece, are large medallions, one bearing in relief, the seal of the State of Indiana, and the others, also in relief, a facsimile of the famous Soldiers' and Sailors' Monument in Indianapolis. Similar medallions are introduced upon all the pieces of the service. Surrounding the medallions are nautilus shells and seaweed, and depending from these are garlands of wild roses or eglantines, which with the oak, sycamore, acorns, and shrubs, symbolize the principal flora and trees of the State.

The centerpiece weighs 297 ounces, or nearly 25 pounds. It is richly gold lined, and over the top is a silver gilt wire network covering for cut flowers, which can be removed, and the dish used as a jardiniere; or if the lining is taken out, it will also serve as a fruit dish. Ranking next to this in richness of effect come the massive candelabra; these have nine lights each, and stand 22½ inches high exclusive of candles and shades, and weigh over 36 pounds. The arms of the candelabra are gracefully twined, and the sconce cups and saucers are formed by the eglantine flowers. The large salver, another of the pieces, is ob-

long in form, 24 inches long, and weighs over 200 ounces. The salver has two handles, and in the large open center space is a fine etching, measuring 11 inches, of the Soldiers' and Sailors' Monument. Beneath the monument, in the center of an elaborate bit of ornamentation, appear the seal of the State of Indiana, and the words, "Presented to the Battleship Indiana by the Citizens of Indiana, 1896." A similar inscription has been introduced as a decoration upon the punch bowl. In addition to these inscriptions, there is etched upon the underside of each piece

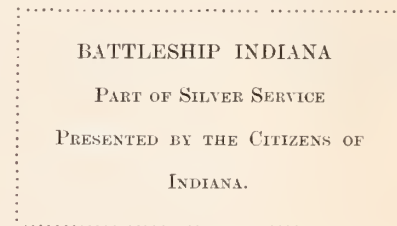

The handsome tea set, consisting of tea kettle, stand and lamp, tea pot, coffee pot, sugar bowl, cream pitcher and slop bowl, weighs over 200 ounces, so that the tray and tea service alone weigh over 34 pounds. Then there is the massive punch bowl, with a capacity of four gallons. In this piece, to the general decorations, have been added grape leaves and large bunches of the fruit. The bowl stands 11 inches high, measures 19½ inches across the top of widest part, and weighs about 18 pounds. The remaining pieces consist of a 24-inch meat dish intended for a large roast; a 26-inch fish dish, an 18-inch meat dish, two round 13-inch entree dishes, two gravy boats, two double vegetable dishes, arranged so that by unlocking the handles from the top, the covers are converted into dishes; four compotiers, each gilt in the center, standing 6¼ inches high; two small fruit dishes, one very handsome ice cream dish with richly decorated lattice work drainer; one ice cream slicer, one salad bowl, spoon and fork, all lined with gold; one ice bowl and tongs, four hors d'oeuvre dishes, gold lined, and one water pitcher with a capacity of 10 pints.

The service was designed by John T. Curran, of Tiffany & Co.'s silver factory, and in its entirety contains nearly 200 pounds of sterling silver, 925-1000 fine. The silver service is fitted into three handsome and substantial oak chests lined with red chamois and bound with brass, and bearing brass plates suitably inscribed.

The executive committee of the Indiana battleship fund is composed of the following gentlemen: Governor Claude Matthews, chairman; Charles R. Williams, vice; Col. Wm. R. Holloway, secretary; John H. Holliday, treasurer; General Lew Wallace, Hon. S. P. Sheerin, Hon. A. W. Brady, Hon. Thomas Taggart and Dr. J. Livingston Thompson. The fund was raised by public subscription under the auspices of the Indianapolis *News*.

The firm lately known as J. W. Williams, King City, Mo., is now known as Williams Bros.

## Our Traveling Representatives



Traveling representatives may consider these columns open for the publication of any news or items of interest regarding themselves or their conferees.

**J**ULY 6th the traveling men for Baldwin, Miller & Co. start out on the road after two weeks' vacation, with a full line of Fall samples. D. J. Reagan goes to Iowa and Oscar Derndinger to southern Indiana.

Traveling men in Pittsburgh, Pa., last week were very few. Among them were: C. M. Dillon, Meriden Cutlery Co.; H. J. Steward, Enos Richardson & Co.; H. C. Walton, Wadsworth Watch Case Co.; Mr. Sinnock, Ehrlich & Sinnock; E. A. Manheimer, Illinois Watch Case Co.

The following traveling salesmen passed through Detroit, Mich., recently: Mr. Gallagher, Sinnock & Sherrill; E. A. Manheimer, Illinois Watch Case Co.; D. I. Byers, Cincinnati Silver and Gold Refining Co.; J. R. Goodwin, Carter, Hastings & Howe; Mr. Foster, Unger Brothers.

Among the traveling men in Boston, Mass., the past week were: G. B. Osborn, William Smith & Co.; William H. Jones, Jones & Woodland; D. Untermeyer, Charles Keller & Co.; Herbert Bliss, Bliss Bros.; George Whiting, S. E. Fisher & Co.; Frank Harmon, M. B. Bryant & Co.; Herbert Barker, John W. Reddall & Co.

Traveling men in Indianapolis, Ind., last week included: Mr. Davis, Wm. Roger Mfg. Co.; C. H. Higbee, Potter & Buffinton; E. A. Manheimer, Illinois Watch Case Co.; Mr. Sinnock, Ehrlich & Sinnock; J. J. Hogan, Rogers & Hamilton Co.; G. C. Hudson, H. F. Barrows & Co. and representatives of F. C. Klein & Bro. and L. H. Keller & Co.

Few and far between are the traveling salesmen in Syracuse, N. Y., these hot days. Noticed in town last week were: M. L. Jacoby, Providence Stock Co.; H. B. Kennion, H. D. Merritt & Co.; Milton S. Rodenberg, S. & B. Lederer; Charles F. Irons, Irons & Russell; C. F. Goodwin; J. W. Phillips, Hamilton & Hamilton, Jr.; M. B. Markman, for A. Wolff; Mr. Pearce, Bay State Optical Co.

Among the salesmen who have called on Cleveland, O., firms the last two or three weeks are: J. R. Goodwin, Carter, Hastings & Howe; Mr. Allen, for A. Wittnauer; Mr. Lane, Geoffroy & Co.; David Kaiser, Lewis, Kaiser & Luthy; Walter Shute, Day, Clark & Co.; Mr. Smith, Bippart & Co.; Mr. Rose, Durand & Co.; and the representatives of M. B. Bryant & Co., Chas. Keller & Co., and others.

Paul R. Shordiche, a popular traveler for Lapp & Flershem, Chicago, and Miss Emma

Blaine, daughter of Mr. and Mrs. Christopher Blaine, were married June 30 at La Grange, Ill. The bride is a charmingly attractive young lady of Reese, Mich. Mr. Gam, of Smith & Gam, Madison, Wis., was best man. The presents were numerous, a set of solid silver flatware being the gift of the groom's co-workers. Paul is a favorite, and there was a shortage of rice and old shoes in La Grange after the wedding.

### San Francisco.

W. P. Morgan has returned from the east. A. Hirschman will move on Aug. 1st from Sutter St. to 10 Post St.

James L. Davis, vice-president of the California Optical Co., is quite ill.

H. H. Adams, of Phelps & Miller, left for the east last week. He is to be gone about six weeks.

Max L. Shirsper has taken charge of the optical department for T. Lundy at the Emporium.

J. W. Babcock, Sacramento, Cal., Joseph Schulte, Jr., Monterey, and N. H. Wilson, Merced, were in town recently on business.

The only son of C. Muller, the pioneer optician of this city, died a few days ago at the age of seven years.

Isadore Nordmann has given up his European trip, and it is said he will look up a business connection in this city.

Among eastern people in town recently were: E. A. Wilkins, Ostby & Barton Co.; J. A. Limbach, Foster & Bailey; H. A. Cobb, Daggett & Clap, and Mr. Block, W. & S. Blackinton.

### Pacific Coast Notes.

W. E. Smith is about to locate in Yreka, Cal.

J. L. Bush has opened a repair shop in Greenville, Cal.

C. E. W. Bowers has opened a new store in Seattle, Wash.

The creditors of H. H. Day, Tacoma, Wash., have agreed on a settlement of 15 cents.

Z. F. Vaughn, Lakeport, Cal., has opened an office at Little Lake Hotel, Willits, Cal.

E. F. Smith, Suisun, Cal., is reported to be packing up his stock intending to retire from business.

A. A. Bocks, formerly of Woodland, Cal., has bought the store of Sam Rich, San José. Mr. Rich will go to Oakland, where he will manage the store of M. Lissner & Co.

George B. Collins, a practical watch maker of Florence, Ore., is thinking of locating at Newport, on the coast of Oregon, where he will establish a small jewelry store.

Judgment by default in favor of the Meriden Britannia Co. for \$600, against William Friedlander, Portland, Ore., has been granted; also one in favor of Z. A. Oppenheimer vs. William Friedlander.

L. L. Berens, formerly in the Fisher block, Whatcom, Wash., has moved to 1375 College St., consolidating his jewelry with the optical business formerly conducted by his father, B. A. Berens. L. L. Berens will manage the combined establishment.

### St. Louis.

Morris and Meyer Bauman, of the L. Bauman Jewelry Co., are in New York.

Mr. Steiner, Sr., father of Fred Steiner, a local jeweler, died and was buried last week.

A. S. Mermod, of the Mermod & Jaccard Jewelry Co., arrived home from his European trip last week.

The Full Jewel Bicycle Club, composed of jewelers and kindred tradesmen, contemplate making a run to Springfield, Ill., in the near future.

Geo. F. Heidet, representing C. F. Rumpp & Sons, Philadelphia, Pa., dealers in fine leather goods and jewelers' novelties, was in town last week.

A suburban land company are extensively advertising lots at \$50 to \$60 each, and offer as an extra inducement to throw in with the first 100 lots sold, a solid gold watch with each lot.

July 6 the E. Jaccard Jewelry Co. commenced to entirely remodel their store. When the improvements are complete this establishment will be one of the finest in the country.

Goodman King, of the Mermod & Jaccard Jewelry Co., told THE CIRCULAR man that the members and employes of the firm were beginning to scatter on their Summer vacations, and that he did not look for much life in the trade for a month or six weeks to come.

One of the largest contracts of the kind ever received by a local firm was obtained recently by the E. Jaccard Jewelry Co. It was for 8000 silver souvenirs for the Suburban Concert Garden, in this city. They will all be given away July 17 and will cost a considerable sum each.

The annual meeting of the Missouri Retail Jewelers' Association will be held on Wednesday evening, July 8. At this meeting the officers and directors to serve the ensuing year will be elected, and the election of delegates to the National Convention will take place. After the business is over there will be a "smoker." The committee appointed by the Missouri Retail Jewelers' Association to disburse the funds given by eastern manufacturers for the cyclone sufferers have made their report. They return thanks to the generous donors and state that about 15 people employed in the trade were relieved. In this connection it might be well to state that there are several watchmakers who have lost their all, and additional funds could be placed to advantage.

Used by the chairmen of the two Republican National conventions, the first of them now being the Republican candidate for President of the United States, the table made by the manual training schools of the South Side high school in 1892, has been returned from St. Louis to Minneapolis. It is now in M. L. Cohen's jewelry store, Minneapolis, where it is awaiting a second silver plate, which will tell its St. Louis history just as the first one relates the part it played in the convention of 1892.



## Philadelphia.

T. Morris Knight is stopping at Atlantic City.

Westcott Bailey has gone to Europe. He was one of the passengers on the *St. Paul* last week.

Charles F. Duffy, Enos Richardson & Co., and Frank L. Wood, Carter, Hastings & Howe, were in Philadelphia last week.

The Howard Sterling Co., of Providence, R. I., have been granted permission to open a branch office in Philadelphia.

Within the next ten days the remaining scholarships provided for by the will of Simon Muhr, deceased, will be awarded. A list of eligibles has been submitted to the persons authorized to make the awards.

Frederick E. Leiber committed suicide at the boarding house, 238 N. 12th St., Sunday, June 28, by shooting himself in the head with a revolver. Ill health and domestic troubles are reported as responsible for the tragic affair. At one time Leiber was a prosperous jeweler of Newark, N. J. He was 48 years of age.

President I. Herzberg, of the Pennsylvania Retail Jewelers' Association, will go to Atlantic City, on Monday, July 13, to make final preparations for the annual convention of the organization to be held there July 14, 15 and 16. It is thought that at least 400 persons connected with the State and National organizations will be present. The National convention will also convene on this occasion.

One of the most elaborate displays of silverware ever seen in this city was on exhibition in several of the Chestnut St. show windows the past week. J. E. Caldwell & Co. displayed the 40 pieces of silverware manufactured for the battleship *Iowa*; Sackett & Co. exhibited the prizes for the People's Regatta; Simons, Bro. & Co. had on display many elaborate cups to be awarded in athletic competitions, and the *Evening Telegraph* window contained the numerous prizes that journal will give in connection with a bicycle carnival on the evening of July 4.

---

## Connecticut.

The Meriden Britannia Co.'s factory shut down July 3, for the Summer vacation.

The clock and watch shops in Thomaston shut down but one day for the Fourth.

The Phelps & Bartholomew Clock Co., Ansonia, have closed until July 13 for inventory and repairs.

W. B. Coulter, the Waterbury optician, has removed his office from the Lilley block to 70 Bank St., room 2.

The Wilcox Silver Plate Co., Meriden, shut down the factory July 2. The date of the factory starting up has not been decided upon.

The factory of the Holmes & Edwards Silver Co., Bridgeport, shut down June 26 for two weeks, during which time the annual inventory will be taken.

The C. Rogers & Bros.' factory, Meriden, shut down Friday for a few days. As soon as boiler and machinery are looked after the factory will start up.

Strauss & Macomber, New London jewelers, give to every purchaser of \$1 worth of goods a sample package of "Witchcloth," for polishing all kinds of metal.

The will of Noah Pomeroy, the deceased clock manufacturer, was admitted to probate in Hartford last Tuesday. All the property is given to his wife, Mary Jane Pomeroy, who is named as executrix.

W. W. Myatt, the Ohio representative of the Meriden Britannia Co., arrived in Meriden Saturday night after a two months' visit to England. Mr. Myatt was a passenger on the *Lucania*, which made a record run during the race with the *St. Paul*.

The land for a union evangelical chapel at Pine Orchard, a Summer shore resort near New Haven, has been provided by the generous donation of a suitable lot by the Messrs. Wallace, of R. Wallace & Sons Mfg. Co., Wallingford. The lot is of ample size, and is a very eligible location, not far from the shores.

C. A. Hamilton, of Waterbury, has been elected president of the newly organized Housatonic Brass Co., successors of the Housatonic Brass Co., whose factory in Wallingford was destroyed by fire a few weeks ago. C. E. Minor, of New Haven, is secretary of the new concern, and E. A. Russell, of New Haven, treasurer. The new company's capital is \$10,000. The new concern will manufacture the same line of brass novelty goods as those made by the old Housatonic Brass Co.

C. Rogers & Bros., Meriden, are having a two-story brick building added to their large factory on Butler St. The building is 81 x 45 feet and will be used for table cutlery purposes in all its branches. On account of the extensive cutlery business of this company they were obliged to build to meet the demand. The new building will be fitted up in first class shape for the manufacture of table cutlery. The steel blanks which have formerly been bought will hereafter be made by the company after the work in the new building is begun. Gilbert Rogers says it will be one of the best equipped factories in the country when finished. All the latest improved machinery for making cutlery will be put in. This new department will employ between 50 and 60 men. The work is being pushed so that they can begin work in it by Aug. 1st.

---

## Syracuse.

Edward C. Howe left Friday for the Thousand Islands accompanied by his wife.

Calvin S. Ball left on July 4th for a stay at his cottage on Round Island, Thousand Islands.

C. A. Richardson, Lebanon, N. H. who failed recently, offers 50 cents on the dollar to settle his indebtedness.

E. B. McClelland's jewelry store will be closed on Saturdays during July and August in accordance with his custom of several years past.

The case of Frederick Tyrell came up in the county court before Judge Ross last Tuesday morning. He pleaded guilty to a charge of petit larceny in stealing a diamond ring

several weeks ago from Chas. H. Miller, jeweler. Judge Ross imposed a sentence of one year's imprisonment in the Onondaga County Penitentiary.

C. E. Eager has a novel advertisement in his Warren St. window. A marksman clad in corduroy is taking aim at a target covered with watches of different sizes. His suit is covered with jeweled pins and badges and a silver mounted pencil represents his rifle. A card in the window announces that "We hit the mark on prices."

---

## Boston.

D. C. Percival, Jr., is having his knockabout *Sally* put in racing trim and will enter her in a number of regattas this month and next.

E. B. Floyd & Co. have been settling up with creditors on the basis of the firm's composition offer, preparatory to continuing business as a corporation.

Last Wednesday night the electric alarm signal in the Bay State Watch Case Co.'s office, 309 Washington St., informed the burglar signal service that someone was within. Since the company ceased manufacturing, their tools have been stored in the old work room, and when the messengers from the burglar alarm company arrived on the scene they found there one John Healy, and he was placed under arrest, charged with breaking and entering. In a room elsewhere in the building, formerly occupied by Healy, the police found a number of tools bearing the stamp of the watch case company.

---

## Pittsburgh.

John Schmidt, formerly a jeweler in Homestead, Pa., died last week at his residence in that town.

D. L. Cleland, Butler, Pa., was in the city last week on his way home from an extended visit to eastern cities.

A special to local papers stated that the store of George Stevenson, Johnstown, Pa., was burned out. No insurance.

William Heeren bought a residence and lot 26x106 feet at Bellefonte and Elmer Sts., Twentieth ward, for \$5,000 from Prof. Gustave Guttenberg.

Visiting jewelers in the city last week were: John Linnenbrink, Rochester, Pa.; E. H. Kennerdell, Tarentum, Pa.; Charles Clark, Cornwallville, Pa.; R. H. Wolfe, Smithton, Pa.; E. L. Walker, Verona, Pa.

The jewelry store of Murray M. Henry, Sinclair St., McKeesport, was closed by the sheriff July 1, on an execution issued by his brother-in-law, J. B. Gillman, for \$1,200. J. K. Skelley has entered a civil suit against Henry for a bill of \$300, and a constable has levied on the goods. Henry has been missing since two weeks ago, and his whereabouts are unknown. Pittsburgh firms were "caught" in this failure.

---

After an absence of four months mostly in the south, Milford E. Bliss is back again in his former position with the Mosberg Mfg. Co., Attleboro, Mass.

## Letters to the Editor.

### VALUABLE INFORMATION ANENT THE DIAMOND TARIFF IN "THE CIRCULAR."

MONTREAL, CAN., July 2d, 1896.

Editor of THE JEWELERS' CIRCULAR:

We beg to thank you very much for the papers and information you have given us about the diamond question; they will be very useful to us. Yours truly,

HENRY BIRKS & SONS.

### NOT A SUBJECT FOR SYMPATHY.

NNW YORK, July 1, 1896.

Editor of THE JEWELERS' CIRCULAR:

The item in to-day's CIRCULAR dated Bridgeport, Conn., June 26th, is incorrect so far as regards the failure of Breckbill & Benedict, and we hardly think that any sympathy need be felt for them. The sympathy if any should be bestowed upon their creditors, who were misled into giving them credit by representations that are believed to be absolutely false.

One partner made a statement less than a year ago that they were worth nearly \$18,000 over and above all their debts and the other partner within three days after, made a statement that they were worth at least \$20,000 over and above all their liabilities. These statements are in existence and can be produced at the proper time.

These people seem to have bought plenty of goods for the dullest period the jewelry trade has ever known and now they make a statement that they are worse off than nothing and want their creditors to accept 25 cents on the dollar.

"Statements" are worthless unless they are true. People who make statements that are not true and obtain credit thereon are criminally liable for obtaining goods under false pretenses and should be held to a strict accountability, as we hope this firm will be.

Truly yours,

A. V.

### DUEBER ANSWERS ROBBINS & APPLETON'S COMMUNICATION AS TO THE COLBY PATENT DECISION.

CANTON, O., July 2, 1896.

Editor of THE JEWELERS' CIRCULAR:

We are not surprised at the communication in THE CIRCULAR, signed by Robbins & Appleton, inasmuch as every statement contained in it is erroneous.

1st. Robbins & Appleton not "sitting in Chambers" as Judges upon future Pendant Setting litigation, cannot be supposed to be infallible in their predictions as to the outcome of any proceeding that may be herein-after instituted affecting the Colby Patent.

2nd. As the validity of Pendant Setting Movement Patents is still a question before the Court, we fail to see how Robbins & Appleton have inside information as to the outcome of such litigation, or any knowledge of which way such suits will be decided, and "bluffs" will not frighten any who care to manufacture Pendant Setting watches.

3d. We agree with the honorable gentlemen that "This patent matter had no relation whatever with the subject of the suits recently

abandoned by" Major Appleton, representing all the defendants in the case.

4th. The statement that "The proposition for the abandonment of the so-called trust suits did not come in any way directly or indirectly from the defendants, but came directly from the plaintiffs, the Dueber Co.," is a deliberate and malicious falsehood, and no one knows better that it is one than Robbins & Appleton.

Yours truly,

THE DUEBER WATCH CASE MFG. CO.,  
Per W. A. Moore, Secretary.

### Proceedings of the Philadelphia Horological Society.

PHILADELPHIA, Pa., July 6.—The regular monthly meeting of the Philadelphia Horological Society was held in its rooms at Bank Hall, S. E. Cor. Broad St. and Columbia Ave., Thursday evening, July 2d. The regular business was disposed of, after which President Lewis continued his lecture on "Friction, Lubrication and the Lubricants in Horology," which will be finished at the next meeting. Any one desiring the lecture in book form can have it by addressing the secretary of the society. The book will be ready for delivery shortly.

It is the intention of the society to establish a bureau for the sale of books pertaining to the trade, and also to take subscriptions for trade periodicals, the revenue to be devoted to the maintenance of the society. The bureau is in charge of a committee who have already quite a number of sample books in the society's rooms, and who will shortly be in possession of all the principal books relating to horology.

The society has added to its membership J. E. Ellis, Toronto, Ont., who, having read the proceedings of the society, sent in his application for membership.

### The Gorham Mfg. Co. Score Another Victory Over An Infringing Dry Goods Store.

Below is given the decision in the case of the Gorham Mfg. Co. vs. Hayden Bros., rendered July 2:

IN THE CIRCUIT COURT OF THE UNITED STATES, WITHIN AND FOR THE DISTRICT OF NEBRASKA.

GORHAM MANUFACTURING COMPANY,  
Complainant,

vs.

Hayden Brothers, and William Hayden, Edward Hayden and Joseph Hayden.  
Defendants,

No. 334,  
Docket R.  
DECREE.

This cause came on to be heard at this term and was argued by counsel, and thereupon upon consideration thereof, it was ordered, adjudged and decreed as follows, viz:

That the said defendants, Hayden Brothers, and William Hayden, Edward Hayden and Joseph Hayden and each of them be and they are hereby perpetually enjoined from in a manner, directly or indirectly, advertising for sale any silverware or goods of any kind, not the make, product or manufacture of the Gorham Manufacturing Company, as "Gorham Silverware," or as in any way characterized or designated by the word "Gorham" or the words "Gorham Manufacturing Company."

## Last Week's Arrivals.

**THE CIRCULAR has perfected arrangements for obtaining the names and hotel addresses of all the latest buyers visiting New York, and each day posts in its office, 189 Broadway, a bulletin which every member of the trade is cordially invited to copy.**

The following out-of-town dealers were registered in New York during the past week:

C. J. Bene, Cincinnati, O., Astor H.; L. M. Sigler, Cincinnati, O., Astor H.; A. M. Field, Asheville, N. C., Astor H.; A. W. Paul, Boston, Mass.; C. R. Connell, Scranton, Pa., H. Imperial; L. Lewis, jewelry buyer for R. H. White & Co., Boston, Mass., 70 Green St.; C. Strobel, Waterbury, Conn., Murray Hill H.; E. Knight, jewelry buyer for Richardson & Knight, Jackson, Mich., 622 Broadway; M. Garson, jewelry buyer for Garson, Kerngood & Co., Rochester, N. Y., H. Imperial; H. Frank, jewelry buyer for H. Frank, Natchez, Miss., 22 Howard St.; O. R. Rick, jewelry buyer for Adam, Meldrum & Anderson, Buffalo, N. Y., 120 Franklin St.; D. Auer, Albany, N. Y., Astor H.; F. R. Biedler, Baltimore, Md., Imperial H.; H. Alkan, Buffalo, N. Y., Astor H.; M. Eiseman, Chicago, Ill., Broadway Central H.; J. W. Field, Galveston, Tex., Everett H.; A. S. Levy and J. Levy, Hamilton, Ont., Astor H.; H. Castelberg, Baltimore, Md., Astor H.

## Trans-Atlantic Voyagers.

### TO EUROPE.

John L. Borsch, Philadelphia, Pa., was a passenger on *La Bourgogne*, which sailed for Europe July 4.

Westcott Bailey, Philadelphia, Pa., J. T. Lynch, New York, and L. M. Sigler, Cleveland, O., were passengers on the *St. Paul*, which sailed July 1.

Geo. E. Marcus, of Marcus & Co., New York, Mr. and Mrs. C. A. Keene, Boston, Mass., and H. Siegel, of L. Straus & Sons, New York, were passengers on the *Lucania*, which sailed July 4.

### FROM EUROPE.

Richard Pinkstone, Philadelphia, Pa., Louis Sickles, of M. Sickles & Sons, Philadelphia, Pa., and M. Van Wezel, New York, arrived from Europe on the *Etruria*.

Emanuel Arnstein, of Arnstein Bros. & Co., New York, and Henry Hirschberg, St. Louis, Mo., arrived on the *Normannia*.

J. S. MacDonald, Baltimore, Md., arrived on the *Germanic*.

M. Goodfriend, of Goodfriend Bros., New York, arrived on the *New York*.

A. S. Mermod, of the Mermod & Jaccard Jewelry Co., St. Louis, Mo., arrived from Europe.

M. Lippert and M. Gordon, jewelers, Denver, Col., have been arrested charged with complicity in the numerous burglaries committed of late. A quantity of chopped-up silverware was found, which has been identified as that belonging to one, Major Downing.

# The Jewelers' Circular

AND  
HOROLOGICAL REVIEW.

PUBLISHED EVERY WEDNESDAY BY

THE JEWELERS' CIRCULAR PUB'G CO.,

189 BROADWAY, NEW YORK CITY.

A JOURNAL DEVOTED TO THE INTERESTS OF JEWELERS, WATCHMAKERS, SILVERSMITHS, ELECTRO-PLATE MANUFACTURERS, AND ALL ENGAGED IN KINDRED BRANCHES OF INDUSTRY.

Member of the American Trade Press Association.

Our Editorial columns will contain our own opinions only, and we shall present in other columns only what we consider of interest or value to our readers. Advertising matter will not be printed as news.

Advertising rates in THE CIRCULAR are lower, considering the number of tradesmen reached by its large circulation, than in any other jewelry journal.

Notices of changes in standing advertisements must be received one week in advance; new matter can be received up to Monday.

## INFORMATION FOR SUBSCRIBERS.

### Terms of Subscription, Postage Prepaid.

	PER ANNUM.
United States and Canada, . . . . .	\$2.00
Foreign Countries in Postal Union, . . . . .	4.00
Single Copies, . . . . .	.10

New Subscribers can commence at any time.

Payments for THE CIRCULAR when sent by mail, should be made in a Post-Office Money Order, Bank Check or Draft, or an Express Money Order or Registered Letter. All postmasters are required to register letters whenever requested to do so.

Pay money only to authorized collectors having proper credentials.

**Returning Copies** Returning your paper will not enable us to discontinue it, as we cannot find your name on our books unless your address is given.

**Changing Address.** In changing address always give the old as well as the new one. Your name cannot be found on our books unless this is done.

**Discontinuances.** We will continue to send papers until there is a specific order to stop, in connection with which all arrearages must be paid; but such an order can be given at any time, to take effect at or after the expiration of the subscription. All such orders will be promptly acknowledged by mail.

**Liability.** The Courts have decided that all subscribers to Journals are responsible until arrearages are paid in full and an order to discontinue has been received by the publisher.

## THE JEWELERS' CIRCULAR IN EUROPE.

Among the Places in Europe where THE JEWELERS' CIRCULAR is on file are the following:

**LONDON**—First Ave. Hotel, Holborn, E. C.; Holborn Viaduct Hotel, Royal Hotel.

**PARIS**—Hotel de L'Athénée, Rue Seribe.

**BERLIN**—Deutsche Uhrmacher Zeitung, Jager-Strasse, 73.

**GENEVA**—Journal Suisse D'Horlogerie.

**AMSTERDAM**—Continental Club, Hotel Amstel.

**ANTWERP**—Diamond Club, Rue de Pelican.

Vol. XXXII. July 8, 1896. No. 23.

Every line of reading matter in THE JEWELERS' CIRCULAR, with the exception of the few brief extracts from exchanges, always properly credited, is written exclusively for this journal. Each issue of THE JEWELERS' CIRCULAR is copyrighted. Permission to quote is extended to other publications, if such quotations are properly credited.

## One Cause of the A PROMINENT Retailers' Dull jobber says that the Trade. continued dulness of trade among the

retail country jewelers is due to the fact that these dealers are not enterprising enough. The retail jeweler lets the trade he ought to have go to the dry goods and notion houses, and then complains that these firms get all the business. The reason these houses are getting the jewelry business of the towns is that they make an attractive display of their goods, and attract customers who have heretofore patronized the jeweler. He said he had been in towns where the jeweler's display was a medley of goods, the arrangement of the show cases lacking all artistic taste or even ordinary care. "I heard one lady remark that she did not believe the jeweler had any salad forks, for she never saw anything of that kind in his store. Probably they were in his safe or covered up with other goods. If the country jeweler hopes to keep his trade he has to wake up and make an effort to hold it."

Though there have been larger circumstances over which the jeweler has no control, entering into the causes of his depressed business, the deductions of this jobber are founded on sound premises. In his methods for bringing his business before the public notice and attention, the jeweler is far behind the dry goods and notions dealers. His advertisements are trite, colorless, unattractive, uninteresting and lacking of business bringing qualities. While the dry goods dealer presents to the public from day to day a list of timely articles and specifies attractive prices, the jeweler advertises his business card with some general statements that have been used so often that whatever effect they may once have produced has long since disappeared. His windows too often contain no effective system of arrangement, while those of the dry goods dealer are one of the interesting features of the town. The jeweler must fight the department stores with their weapons. All things being equal or even nearly equal, the average person would rather buy jewelry, watches, silverware, clocks, fine bric-à-brac, cut glass, etc., in a jewelry store than in a department store. The disposition of the country jeweler of preferring to tinker a watch to making a sale, must also be entirely dissipated before he can compete successfully with the accomplished merchant, as the dry goods man usually is.

## Changes in the Do- AS we pointed out minion Tariff. of THE CIRCULAR

tariff revision is among the probabilities that Canadian business men may be called upon to face as a result of the recent election. It is not likely, however, that there will be any material changes so far as relates to the jewelry and kindred trades. The cry that a change of government was likely to result in a general disturbance of business interests was raised purely for political effect. Though the Liberal party are

theoretically free traders, it is universally admitted that the people will not hear of direct taxation, and that revenue requirements will necessitate the maintenance of the tariff substantially as at present. Any modifications which the incoming government are likely to make—which cannot in any event be considerable—will be in the direction of cheapening necessities of life and raw materials in the staple lines of manufacture. There is no industry which has less reason to dread interference than the jewelry and silverware, these products being considered under a revenue tariff, legitimate subjects for high taxation. The proposers of an increased tariff on diamonds will be met with a rehearsal of the experiences of the United States Government in this connection, as narrated in several issues of THE JEWELERS' CIRCULAR, and it is not at all likely that the schedule will be changed. Whatever changes may eventually be brought about, it is not expected that any effort will be made to revise the tariff at the short Summer session of the Dominion Parliament. It seems to be regarded as probable that the period intervening between the present and the early part of next year will be taken up by a careful inquiry into the conditions of the industries to be affected by tariff changes. It is not thought likely, according to present information, that the principle of protection will be entirely eliminated in the effort to bring the tariff rates to a revenue basis.

## Eugene F. Cuendet Allowed \$2,000 a Year to Maintain His Station.

ST. LOUIS, Mo., July 3.—On Wednesday, July 1st, the St. Louis Probate Court gave Eugene F. Cuendet an allowance of \$2,000 a year. This was done to enable him to maintain himself in keeping with his station in society. He filed a statement making substantially the following claims: He is the son of the late Eugene J. Cuendet, of the E. Jaccard Jewelry Co., who died in 1894. He is at present 17 years of age, and upon attaining his majority will inherit the following amounts: \$250,000 from his father's estate, \$60,000 from his grandfather's estate, and \$6,500 from his grandmother's estate. In his petition he states that he is learning the business with a view to becoming manager of the E. Jaccard Jewelry Co., that he desires to extend his acquaintance among the trade, and that it is necessary he come out in a social way. But to do this requires money. His curator, Reed Northrop, allows him \$1,500, but he figured that \$2,000 a year was necessary. He assured the Court that he had no bad habits such as the use of intoxicants, but on the contrary his tastes were very modest, and averred that if given the \$2,000 he would not squander it but would carefully use it for the purposes indicated.

From all accounts the young man is as he represents himself to be. He is of exceptional good habits, and the amount he asks for, considering his prospective wealth, is not extravagant. I am told that he will inherit in round numbers from all sources fully \$500,000.

### New York Notes.

Sol. Lindenborn has filed a judgment against Markus Singer for \$1,043.73.

R., L. & M. Friedlander have entered a judgment for \$635.02 against Isaac Boltansky.

A judgment for \$166.57 against Joseph and Amelia Rundback has been entered by T. C. Campbell.

The jewelry business of Thomas Kirkpatrick, now at 941 Broadway, will be removed next Fall, to Fifth Ave. and 33d St.

The trade are cautioned to deal guardedly with a man who, representing himself as a real estate dealer from Yonkers, has attempted to get goods on memorandum from firms in Maiden Lane and vicinity.

An error last week made it appear that Rud C. Hahn has been elected to the New York Jewelers' Board of Trade. Mr. Hahn was elected a member of the New York Jewelers' Association, 146 Broadway.

Albert C. Wall, receiver of the Chas. Jacques Clock Co., 22 Cortlandt St., New York, notifies all creditors to present their verified claims to him at 1 Montgomery St., Jersey City, N. J., on or before Sept. 1, 1896.

In the Morrisania Police Court, Wednesday C. W. Mayer, who said he was a jeweler, of 308 E. 75th St., was charged by Mrs. Julia Tompkins, of West Chester, with the larceny of jewelry valued at \$125, and was held in \$1,000 bail for trial by Magistrate Cornell.

De Los McCurdy, counsel for the silver-smiths indicted at the instigation of the department stores on charges of violating the silver law, said Friday that from assurances he had been given by the District Attorney, the trial of these cases would not go over until Fall, but would come up during the hot weather.

The New York Jewelers' Board of Trade have received from their Atlanta attorney a draft for about \$3,500, being 25 per cent. cash settlement and all expenses incurred, as well as attorneys' fees and court costs in the matter of A. F. Pickert. The creditors' bill instituted in behalf of the creditors represented by the Board has been dismissed.

The last payment to the creditors of Wm. H. Sandifer, formerly a jeweler under the Fifth Avenue Hotel, who failed three years ago, was recently made by Frederick Beltz, the substituted trustee of Mr. Sandifer. The total amount which the creditors received was 40 per cent. on their claims. This was taken as a compromise and releases of indebtedness have been executed to Mr. Sandifer.

Jacobson Bros., diamond dealers, of this city, have made an application at St. Paul, Minn., for the appointment of a receiver for Topliff & Co., jewelers, of that place. They allege that they are creditors to the amount of \$750; that Topliff & Co. have turned over their stock to L. B. Booker for \$17,000, when it is worth much more than that, and that the notes of Booker running for 21 and 25 years were taken.

By a deal consummated Monday afternoon C. W. Schumann's Sons have purchased from

Mrs. Lynch her interest in the lease of the store occupied by this firm at 22d St. and Broadway. Mrs. Lynch held a lease of the premises for the nominal sum of \$14,000 per annum and relet the store to C. W. Schumann's Sons about five years ago at \$21,000 per annum, an advance of \$7,000. By the arrangements made Monday Messrs. Schumann paid \$25,000 cash to Mrs. Lynch for the equity in her lease which has yet six years to run.

A special meeting of the stockholders of the Leroy W. Fairchild & Co., manufacturers of gold pens and novelties, 290 Fourth Ave., will be held at the company's office, July 30th. The meeting is called to determine whether or not the capital stock of the company shall be increased to \$75,000.

On Monday Emil Magnus, a dealer in cutlery and plated ware, 20 Warren St., made an assignment to William G. Chittick, Jr., giving preference for \$1,990, as follows:—Aglæ H. Magnus for \$1,325; to Louis Gates for \$165, and to the Bridgeport Silver Plate Co. for \$500.

An attachment for \$938.50 was recently issued to the sheriff against Philip Robinson & Co. and L. Kellar & Co., diamond dealers, London, England, in favor of Selden R. Hopkins. The attachment was issued in an action about to be commenced by Hopkins to recover the value of his services as accountant. The sheriff levied on the claim of Philip Robinson & Co. against M. Fox & Co. A CIRCULAR reporter was informed Friday that the case would probably be adjusted by the parties in interest within a few days.

The trial of Mrs. Charles Querin and one Rheinhardt, charged with larceny by Frank Polatschek, formerly an instalment jeweler at 191 Broadway, came up before Judge Cowing, in General Sessions, June 30. The husband of Mrs. Querin is alleged to have caused Polatschek's recent failure by absconding after stealing and pawning several thousand dollars' worth of jewelry, and Mrs. Querin and Rheinhardt were indicted as confederates. On the trial Polatschek told his story, and Rheinhardt confessed his share in pawning the jewelry. The prisoners' lawyer argued that the defendants had not committed larceny, since they acted under the orders of Querin, from whom they received the goods. Judge Cowing sustained them, saying "these people should have been indicted for a conspiracy to defraud, not for larceny."

Unger Bros., Newark, N. J., have purchased the frame factory on Bleecker St., adjoining their big jewelry manufacturing plant, known as the Paxton factory. The purchase was made of James T. Ball, and the old shop will be torn down immediately to make room for a large extension to the Unger plant. This is the third time in the last few months that this firm have made additions to their shops, and when this extension is completed the capacity of the plant will have been more than trebled. The factories will now extend through the entire block, from Halsey St. to Bleecker St.

### Providence.

All communications for this column, addressed to P. O. Box 1093, Providence, will receive prompt attention.

Dutée Wilcox has been elected a director of the City Savings Bank.

Daggett & Robbins have started in the manufacture of 14 k gold rings, pins, etc., at 7 Beverly St.

Frank M. Bloomer, of C. G. Bloomer & Sons, and wife have been enjoying a delightful carriage drive through Connecticut.

Horace Remington is about to build two 2½ story two family houses at the corner of Lenox Ave. and Melrose St.

A quarterly dividend of 11-2 per cent. upon the preferred and common stock of the Gorham Mfg. Co. was payable on the 1st inst.

B. A. Ballou, who was severely injured by being thrown from his carriage nearly two years ago, is able to be out by the use of crutches.

J. P. Trafton, Los Angeles, Cal.; A. Rosenfeld, New York; and Mark Streicher, M. Streicher & Co., Chicago, were among the visitors here last week.

Charles A. Towne *et ux.* have discharged two real estate mortgages, amounting to \$2,400, held by the Roger Williams Savings Fund and Loan Association, and one of \$375, held by S. A. Randall & Son.

The copartnership heretofore existing between Winfred S. Luther and William Norton as W. S. Luther & Co., manufacturing jewelers, has been dissolved by the withdrawal of Mr. Luther. The business will be continued by Mr. Norton, as William Norton, at 19 Page St.

Capt. Jerome Fitzgerald, son of Michael Fitzgerald, and recently of the Hope Silver Mfg. Co., this city, was united in marriage to Miss Christine C. O'Keefe, at St. John's Church, on the 1st inst. The couple will reside in Toronto, Can., where Mr. Fitzgerald is now engaged in business.

Mrs. Sarah Hopkins, wife of James N. Hopkins, well known in manufacturing jewelry circles of this city, died at her husband's residence last Sunday morning, in the 75th year of her age. She had been a kind, benevolent woman. The golden wedding of herself and husband was celebrated a little over four years ago.

Judge Tillinghast, on Tuesday last, authorized James M. Scott, assignee of Wood, Bicknell & Potter, to carry on the business of his assignors until Jan. 1, 1897, at the risk of said insolvent estate. The petition of Assignee Scott was, a short time ago, referred to Lorin M. Cook, registrar in insolvency, and on the latter's recommendation the request to be permitted to continue the business was granted.

The following jewelers of Springfield, Mass., closed their stores all day July 4: L. S. Stowe & Co., Robinson & Son, E. A. Whipple, F. E. Ladd, F. A. Hubbard, Chris. Kuenzel, Eldredge & Penny, A. O. Winans, Woods & Hosley, Charles S. Saxton, Albert A. Bush, M. D. Fletcher, J. F. Burpee & Co., jewelry department.

## Special Notices.

Rates 75c. per insertion for notices not exceeding 3 lines (25 words); additional words 2 cents each. If answers are to be forwarded, postage stamps must be enclosed. Two insertions, 15 per cent. off, three insertions, 20 per cent off; four insertions or more, 25 per cent. off. Payable strictly in advance. Display cards on this page will be charged at \$2.00 per inch for first insertion, subject to same discount as above for subsequent insertions.

Under the heading of **Situations Wanted** on this page advertisements will be inserted for **One Cent a Word** each insertion, no discount. This offer refers to **Situations Wanted only**. Payable strictly in advance. If answers are to be forwarded, postage must be enclosed.

## Situations Wanted.

*Notices under this heading ONLY are charged at one cent a word, payable strictly in advance. If answer are to be forwarded, postage must be enclosed.*

**POSITION** as traveling salesman for South and South-western states, in jewelry or kindred lines. Address G. D., care **JEWELERS' CIRCULAR**.

**POSITION WANTED** by a young man. 21 years of age, 5 years' experience; can do watch and clock work and jewelry repairing. Address Walter A. Willmot, Salem, N. J.

**POSITION** by young man to travel south and south west with his father, who has had 10 years' experience; expenses and small salary. Address M. K., care **JEWELERS' CIRCULAR**.

**POSITION WANTED**, by traveling salesman; 10 years on road for Maiden Lane house in Middle and Western states; AI references; who wants my services? Hustler, care **JEWELERS' CIRCULAR**.

**WANTED**.—Position in wholesale or retail store by young man 25 years of age; have had seven years' experience in retail store and have managed one for the past three years; am first-class workman on watches, clocks and jewelry jobbing; also good salesman; best of recommendations. Address N. Y. 72, care **JEWELERS' CIRCULAR**.

## Help Wanted.

**WANTED**—Two retail optical salesmen of good appearance, and capable of adjusting frames; references required. Address Accurate, care **JEWELERS' CIRCULAR**.

**WANTED**.—Experienced traveling salesman to handle best American line of spectacles through New York State and the East. Address Optics, care **JEWELERS' CIRCULAR**.

**WANTED**.—A first class jewelry salesman, one with an acquaintance with New England retail trade preferred, to carry a gold line; only those willing to work need apply. Address, stating age, experience, reference and salary, to R. P., care **JEWELERS' CIRCULAR**.

## Business Opportunities.

**SPLENDID OPPORTUNITY** for a good workman, Brooklyn, N. Y.; good location, work pays all expenses, rooms in rear of store for living, all for \$600, half its value. Address B. N. Y., care **JEWELERS' CIRCULAR**.

**\$1,200** will buy my 6,800 lb. steel-lined safe, plate glass store fixtures and balance of my clocks and silverware; will sell watches and jewelry if wanted; best opening in Oklahoma for a live jeweler. Chas. E. Rose, El Reno, Oklahoma.

**FOR SALE** in Philadelphia, a desirable business in a fine locality; clean stock about \$8,000, which can be reduced if desired; walnut fixtures, fine regulator, safes, etc; good run of work; established 12 years. Address O. E., care **JEWELERS' CIRCULAR**.

**\$650.00 SPOT CASH** buys fixtures, material and optical goods of leading jewelry and optical store; established 15 years; western New York; bench work \$1,500 per year; only optician; will sell any other part of stock if desired. Address J. O., care **JEWELERS' CIRCULAR**.

## Miscellaneous.

**WANTED**.—Grading mill, drop presses and other machinery for the manufacture of sterling silver flatware. Address Box 299, Syracuse, N. Y.

**J. W. RANDALL**, Mountain Grove, Mo., watch-maker for the trade. Write for prices; send 15 cents for sample staff; always send the old one if possible. I can save you money.

## FOR RENT.

Large Office, **Corbin Building**, 5th Floor - -

Will let very low for **Three Years**.

APPLY, - - - -

**JOSEPH FAHYS & CO.,**  
NO. 54 MAIDEN LANE, N. Y.

## FOR SALE.

Two Fine Black Walnut Wall Cases, twelve feet long. Two twenty-four feet long. One twenty-five feet long. These cases have vertical sliding doors, and were made by B. & W. B. Smith, and are in perfect condition.

**REED & BARTON,**  
37 Union Square, New York



**WE HAVE ON HAND**

A Large Number of Small **Advertising Cuts**

Specially Designed for **JEWELERS' ADVERTISING**, such as above, at **75 Cents per Electrotype.**

SEND FOR PROOF SHEET.

**THE JEWELERS' CIRCULAR PUB. CO.,**  
189 Broadway, New York.



## A Loving Wife's Advice.

She urges her worrying husband, in order to increase his business, to read from week to week

**THE 20 DEPARTMENTS**

IN **THE JEWELERS' CIRCULAR,**  
**\$2 00 PER YEAR.**

## The Latest Patents.

ISSUE OF JUNE 30, 1896.

*NOTE: Owing to the late receipt of the number of the Official Gazette of the Patent Office of above date, the diagrams of the following patents are unavoidably omitted. They will be published in the next issue of THE CIRCULAR.*

**562,812.** FOUNTAIN PEN. VERNE E. MINICH, Paola, Kans.—Filed Oct. 24, 1895. Serial No. 566,742. (No model.)

**562,953.** BUCKLE. JOSEPH FORSHEIM, New York, N. Y.—Filed Mar. 24, 1896. Serial No. 584,601. (No model.)

**562,998.** WATCH-BOW PLIERS. HENRY W. WILDT, Alexandria, Va.—Filed Feb. 26, 1896. Serial No. 580,791. (No model.)

**563,052.** ELECTRIC PROGRAM-CLOCK. DORA OGDEN, Columbus, Ind., assignor of one-half to Gerie L. Reeves, same place.—Filed Oct. 12, 1895. Serial No. 565,442. (No model.)

**563,126.** NOSE PIECE FOR EYEGLASSES. JOHN L. BORSCH, Philadelphia, Pa.—Filed Jan. 2, 1896. Serial No. 573,989. (No model.)

**DESIGN 25,687.** BADGE. CHARLES REHLIN, Allegheny, Pa.—Filed April 10, 1896. Serial No. 587,033. Term of patent, 3½ years.

**DESIGN 25,688.** BADGE. HENRY DOTZENROTH, Pittsburg, Pa., assignor to Leopold W. Vilsack, same place.—Filed March 26, 1896. Serial No. 585,028. Term of patent, 3½ years.

**DESIGN 25,689.** FINGER RING. FRANCIS J. LINGG, Philadelphia, Pa.—Filed April 27, 1896. Serial No. 589,327. Term of patent, 7 years.

**DESIGN 25,690.** SPOON, ETC. EDWARD W. SCOTT, Attleboro, Mass., assignor to the Watson & Newell Company, same place.—Filed Feb. 25, 1895. Serial No. 589,749. Term of patent, 7 years.

**DESIGN 25,691.** HANDLE FOR SPOONS, &C. WILLIAM C. CODMAN, Providence, R. I., assignor to the Gorham Manufacturing Company, same place.—Filed May 29, 1896. Serial No. 593,673. Term of patent, 14 years.

**DESIGN 25,692.** HANDLE FOR SPOONS, &C. AUSTIN F. JACKSON, Taunton, Mass.—Filed May 26, 1896. Serial No. 593,184. Term of patent, 7 years.

**DESIGN 25,693.** HANDLE FOR SPOONS, &C. GEORGE ROCKWELL, Meriden, Conn.—Filed May 27, 1896. Serial No. 593,346. Term of patent, 7 years.

**DESIGN 25,694.** WATCH-PLATE. WEBSTER C. BALL, Cleveland, Ohio.—Filed Feb. 26, 1894. Serial No. 501,607. Term of patent, 14 years.

**DESIGN 25,695.** WATCH-PLATE. WEBSTER C. BALL, Cleveland, Ohio.—Filed Feb. 26, 1894. Serial No. 501,608. Term of patent, 14 years.

**DESIGN 25,696.** WATCH-CROWN. WILLIS S. RICHARDSON, Newark, N. J.—Filed March 18, 1896. Serial No. 583,819. Term of patent, 7 years.

**DESIGN 25,697.** COLLAR BUTTON. BARNET I. JOHNSTON, Lafayette, Ind.—Filed Nov. 8, 1895. Serial No. 568,366. Term of patent, 14 years.

**DESIGN 25,703.** BOOK-MARK. ANNA M. ROTHERY, New York, N. Y.—Filed May 22, 1896. Serial No. 592,652. Term of patent, 14 years.



It Pours Good Things  
IN  
**THE JEWELERS' CIRCULAR!**

Optical Department, Workshop  
No es. Retail Advertising, Sea-on  
able Fashions, Buyers' Bureau.  
Connoisseur.

**\$2 per year—1c per week,**

THE STAR OF EMPIRE WESTWARD TAKES ITS WAY

# WESTERN SUPPLEMENT

## of THE JEWELERS' CIRCULAR

VOL. XXXII.

CHICAGO, WEDNESDAY, JULY 8, 1896.

NO. 23.

### Chicago Notes.

All communications in reference to the Chicago department of *The Jewelers' Circular*, addressed to S. Parlin, 270 Garfield Ave., Chicago, will receive immediate attention.

Sol Kaiser went east Saturday for a couple of weeks.

Mr. Stephens, Escanaba, Mich., bought goods here last week.

C. E. Patterson, Towle Mfg. Co., came in to attend the wedding of a sister.

Methvin Bros., Temple, Tex., were among buyers for the week from a distance.

G. W. McLellan, of G. W. McLellan & Bros. St. Paul, Minn., called on the trade last week.

Al. Sproehnle took a few days' recreation at Brown's Lake, Wis., 80 miles from Chicago, going and returning a wheel.

Vice-president George H. Robinson, of the Gorham Mfg. Co., was at the Chicago sales-rooms a couple of days last week.

C. D. Peacock moved, Tuesday of last week, into his new retail jewelry palace, northeast corner State and Adams Sts.

Lem Flershem went to Detroit the middle of the week to meet Mrs. Flershem, who had been visiting a son and daughter at eastern colleges.

A. L. Sercomb and family are enjoying an outing at Norwood, Mich., and will probably be there a month, Mr. Sercomb making frequent visits to Chicago.

Mr. Gleason, C. H. Knights & Co., is back from a visit to his old home in Windham County, Vt., the home also of the senior member of the firm.

Silver houses report improved conditions generally, with increased sales over those of a year ago. Jobbers in general lines notice a slightly better trade, but not so marked an increase as in silver and optical lines.

"We have just wound up our business for the first six months of 1896," said Louis Manheimer, "and I find it considerably ahead of the same months last year. I look for a good Fall trade and am buying largely with that idea."

F. G. Thearle, Jr., was called home by phone Wednesday of last week by the

serious illness of Mrs. Thearle, who had suffered a stroke of paralysis, affecting one entire side. Mrs. Thearle was resting easier late in the week.

There is absolutely nothing in the report that the Elgin National Watch Co. have received an order for 100,000 watches. The report was denied at the time by Mr. Avery, and he said to *THE CIRCULAR* reporter that there was no basis for such a report.

Ferguson & Craig is the name of a new jewelry firm just opening up in Champaign, Ill. Mr. Ferguson was formerly with H. F. Steck, Washington, Ia., and Mr. Craig is also an Iowa boy, hailing from Oskaloosa. The firm paid cash for their goods and seem wide-awake young business men.

Chamberlain & Allen, Marshalltown, Ia., some six months ago dissolved partnership, Mr. Chamberlain continuing the business. George J. Allen's retirement was caused by continued ill health. He has now completely regained health and opened a new store in that city.

### Cincinnati.

J. Somers, of Bene, Lindenber & Co., is at French Lick Springs during July.

C. J. F. Bene is in the east and will wind up at New York, where he will buy more new goods for the firm.

Visitors in town last week were: Fred J. H. Schell, Xenia; A. Aaron, Springfield, and Dr. LeFevre, Hillsboro.

A. G. Schwab, of A. G. Schwab & Bro., leaves for New York this week. Mose Schwab is taking a vacation, and will return this week.

D. Jacobs & Co., wholesale jewelers, W. 6th St., have moved into very handsome quarters at 604 Race St. which are being fitted in modern style.

S. Labusher, northwest traveler for O. E. Bell & Co., will go to his home at Milwaukee for a short vacation and return to go on his trip the latter part of the month.

Albert Bros. are beginning to receive early shipments of silver novelties, and sales are already being made in the very handsome toilet

sets which have nothing cheap about them except the price.

J. W. Abbott, who conducts a jewelry and notion store at Pocahontas, W. Va., is in Cincinnati hunting his wife, who ran away with the stock while he was away on a visit. He offers a reward for her apprehension or the recovery of his goods.

The baseball nines of Jos. Noterman & Co. and A. & J. Plaut played a game at the Country Club grounds last Saturday, the former winning by a score of 36 to 10. After the game the two nines were the guests of Jos. Noterman at the club house. About a hundred jewelers were among the interested spectators.

Ed. Crononger, of the firm of Eichelberger & Co., manufacturing jewelers, W. 5th St., has been selected as grand marshal and leader in the monster parade of bicyclers on Aug. 3, in which 30,000 cyclers are expected to participate from Cincinnati and the surrounding suburbs, including Covington and Newport.

The opticians will come together this week and form the association which has been in embryo the past month. They are very much in earnest, and having felt the pulse of the trade at large in the State, they feel encouraged to go ahead and organize. The temporary organization at Cincinnati has not been idle. Numerous inquiries are coming in from the country trade regarding the association.

### Canada and the Provinces.

Mr. Leiser, of Lenz & Leiser, Victoria, B. C., was in Toronto a few days since.

F. C. Davey, jeweler, Deseronto, Ont., was married on June 24th to Miss Tillie Wilson, Belleville.

W. H. Scott, jeweler, Queen St. W., Toronto, has left on a trip to England expecting to be absent two months.

Provincial buyers in Toronto last week included: J. L. Wilson, Woodstock; J. W. Jackson, St. Thomas; L. Atkinson, Newmarket, W. H. Hooper, Cobourg.

W. J. Barr, manager of the Goldsmiths' Stock Co., Toronto, left last week on a purchasing trip to New York, Boston and the Attleboros. He will return about the 15th.



**ASK YOUR JOBBER FOR  
S. O. BIGNEY & CO.'S HIGH  
GRADE**

# CHAINS

**THEY EQUAL SOLID GOLD IN STYLE AND FINISH.**

NOTE TRADE-MARK.

**San Francisco.**

Leon Carrau, of Carrau & Green, has returned from a trip to Alaska.

Col. Andrew . of the Diamond Palace, will begin an auction sale on Sept. 1st.

W. K. Vanderslice is spending his Summer vacation at Los Gatos with his family.

A. Armer, of Armer & Weinshenk, has gone up the Sacramento valley on business.

Charles Hadenfeldt, of Rothschild & Hadenfeldt, has gone to New York on a seven weeks' trip.

M. L. Levy had \$1,700 of stock in the San José Street Railroad Co., which recently failed.

Charles H. Steinmetz, for 28 years a watchmaker in San Francisco, has gone to Suisun to locate.

Nat Raphael has given notice that he will go out of business in this city by the first of next year.

W. K. Barmour, representing the Keystone Watch Case Co., has returned from an extended fishing expedition up the coast to Point Arena.

The creditors of A. Steffanoni, Oakland, have granted him an extension of time. He is a good business man and will likely pull out of his present embarrassment.

E. A. Heuschobler, Port Townsend, Wash., has been in town looking up an available opening for business in California. He has decided to remain in Port Townsend for the present.

Sheriff Whelan June 22 served an attachment on the stock of jewelry belonging to Thomas Lundy, at the Emporium, to secure a claim for \$299 in favor of Thomas W. Beals.

Trade is reported generally duller than at this time last year. Among the recent arrivals in town from the interior were John Hood, Santa Rosa, H. Jacoby, Oroville, and Charles Noack, Sacramento.

Alfred Isson has asked the Grand Jury to indict Superior Judge Sanderson for malfeasance in office. Isson sued his brother-in-law, George Stierlen, for \$50,000 for alienating his wife's affections. Certain letters in the case the Judge held pending the appeal of the damage suit and refused to deliver them to Isson.

**Pacific Coast Notes.**

C. Truelson, Petaluma, Cal., has re-established himself in business in that town.

J. K. Bayse, Seattle, Wash., recently took a short trip to Juneau, Alaska.

Faraday & Monette have opened in the jewelry business in Trail Creek, B. C.

Edward B. Lewis, Pacific Grove, Cal., has erected a beautiful two-story residence on Forest Ave.

George Muller, San Francisco, has opened up a watchmaking and optical store in Auburn, Cal.

The store of D. Jonas, of Santa Cruz, Cal., was burglarized recently, three trays of jewelry being taken.

S. J. Smith, jeweler, is now located at La Porte, Cal., and will remain in that section for a short time.

The tower in the large Fithian Block, Santa Barbara Cal., will be surmounted by a handsome clock.

A. Corwin, a Stockton jeweler, is about to open a jewelry store in Merced, Cal., where he was once a resident.

J. R. Densmore has moved his jewelry business into the building formerly occupied by D. C. Clapp, at Azusa, Cal.

Julius Lutke, who was for several years in Ukiah, Cal., sold out and has gone to Healdsburg, Cal., where he will continue the jewelry business.

C. H. Wright has in his show window in Eureka, Cal., three pair of spectacles that are real curios. They are very crude affairs and were in use 120 years.

A. Feldenheimer, Portland, Ore., has secured permission from the city council to erect a large ornamental and useful clock in front of his new store.

Mrs. Truslow, wife of jeweler F. A. Truslow, Redlands, Cal., joined her husband on June 17th, coming out with her two children from Johnson City, Tenn.

Charles D. Platt, the Los Angeles jeweler who was recently arrested on a charge of malicious mischief, has obtained his freedom, and has located at 175 Court St.

A. O. Gott, jeweler, Alameda, Cal., has constructed a working model of the apparatus necessary to control the clappers when they strike the bells of a set of chimes for the City Hall that shall ring out "America" twice every day.

The D. F. Wetzel Co., Spokane, Wash., have incorporated with a capital stock of \$10,000 in single shares of \$1.00, to do a wholesale and retail jewelry business and repairing of all kinds. D. F. Wetzel, W. M. Byers and H. Lange are the promoters.

**THE PERFECTION SHOW CASE**

FOR FINE JEWELRY TRADE.

WE CHALLENGE THE WORLD TO PRODUCE ITS EQUAL.

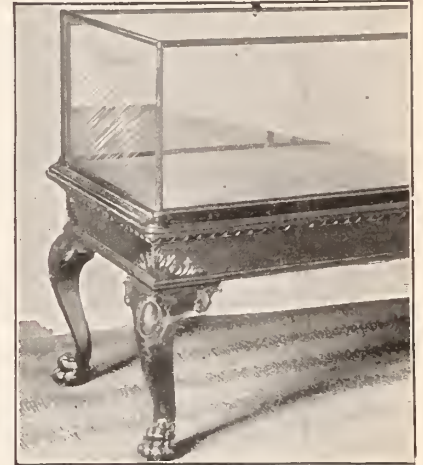

IF YOU ARE INTERESTED IN SHOW CASES AND JEWELRY FURNITURE, WRITE US FOR FULL INFORMATION.

**A. H. REVELL & CO.,**

431 to 437 Fifth Avenue, Chicago.

**AUSTRALIAN OPALS**

IN THE ROUGH—TRADE ONLY

ARTHUR F. CATE,  
1125 WALNUT ST., - - DES MOINES, IOWA, U. S. A.

**PARSONS & SCHOOL**

FOR WATCHMAKERS,  
PEORIA, - - - - - ILL

Send for Circular and Terms.  
**PARSONS & CO.**

**TOWLE MANUFACTURING COMPANY, NEWBURYPORT, MASS. SILVERSMITHS.**



CHICAGO.

LEMONADE SPOON.

ICED TEA,  
ICED COFFEE,  
LEMONADE.

**Colonial** TABLE WARE IN STERLING SILVER.



SOLD ONLY TO JEWELERS.

The police department of Spokane, Wash., has enough spurious jewelry on hand to stock a good sized store. This consists of gold spectacles, rings and a variety of stones, which have been found on the persons of hobos and other prisoners.

Albert Mayer, secretary and treasurer of the Empire Jewelry Co., Seattle, Wash., was married on June 14th to Miss Leah Phillips, daughter of Mr. and Mrs. Phillips, formerly of Victoria, B. C.

**Cleveland, O.**

A. T. Hubbard, of the Cowell & Hubbard Co., is spending a month at Alexandria Bay, N. Y.

R. E. Burdick, of the Bowler & Burdick Co., is at present in Europe on a trip com-

binning pleasure and business.

About the only goods that are being sold by Cleveland jewelers are articles for ladies' Summer wear, such as belts, blouse sets, etc. During the month of June there were a number of large weddings which enlivened the silver business to some extent, but the normal trade calls for fancy articles in silver with some little call for gold goods.

**Detroit.**

A. W. Kludt, Lennox, Mich., purchased goods here last week.

L. Black & Co. will remove into new quarters at 156 Woodward Ave., July 10.

A severe wind and rain storm recently blew in several windows of the store of Wright, Kay & Co. and leveled their big sign to the pavement.

Prizes for the races and sporting events held by the Congregational churches of the city last week were donated by Hugh Connolly and LeHeup & Thomas, jewelers.

Frank P. D'Arcy, jeweler, Kalamazoo, Mich., recently stocked up W. H. Snyder, who gave a chattel mortgage to George H. Phillips. Snyder, it appears, also gave a bill of sale to a brother. Last week Mr. D'Arcy began suit in replevin to recover, and succeeded in finding part of the goods.

George L. Lowe got out 1,000 badges for the Evacuation Day exercises, which will take place here July 11. On that date, 1796, the British left Fort Shelby for good. On one side of the medal is a fac-simile of Fort Shelby and on the other the circumscription.

**Indianapolis.**

Julius C. Walk & Son took their annual inventory of stock last week.

Jas. M. Comstock has been elected treasurer of the Indianapolis Cycle Club.

Chas. Forger will shortly open a new jewelry store in Franklin, Ind.

John Phillips and John Johnson, the diamond thieves who perpetrated a bold theft on jeweler W. J. Strang, Terre Haute, Ind., last February, were sentenced July 1st to two years in the penitentiary.

In a long list of prizes for the bicycle meet, July 4th, were a great variety of articles, but the jewelers furnished the bulk of them: Four gold medals valued at \$73, six watches valued at \$110 and 14 diamond rings and studs valued at \$354.

A man registering as J. D. Rodman, of New York, spent several days last week in Richmond, Ind., and represented himself as a traveling salesman for the Max Marx Cigar Co., of New York. He visited Chas. H. Hamer's jewelry store and purchased a diamond ring for \$75, in payment presenting a check drawn on Max Marx & Co. Rodman was given the ring and change without arousing suspicion, but upon settling his hotel bill with a similar check the clerk had him arrested. The checks proved to have been forged.



**WITCHKLOTH.**

A specially prepared Kloth. Will remove tarnish from Silver and Gold instantly. Selling by the thousands to families for home use.

No. 1 SIZE, PER GROSS, - - - \$12.00  
 No. 2 " " " - - - 24.00

**LAPP & FLERSHEM,**

WHOLESALE SUPPLY AGENTS TO JEWELERS OF THIS KLOTH.

195, 197, 199 STATE STREET, CHICAGO, ILL.

NEVER BLOTS ADJUSTABLE ALWAYS READY.



**The Whitney Adjustable Fountain Pen.**

The only pen made using adjustable feed to regulate the flow of ink.

EVERY PEN GUARANTEED

and money refunded if not satisfactory. Retailers from \$1.75 to \$5.00. Write for catalogue and discounts to dealers.

R. W. WHITNEY, 236 SUPERIOR ST., CLEVELAND, O.

EST. 1870. DR. PETER HENRY, SPECIALIST IN Watch Case Diseases



Key Winders changed to Stem Winder  
 Hunting Case changed to O.s  
 English Case changed to fit American movements  
 Can be cured at  
 53 LONGWORTH ST., Cincinnati, Ohio.

**ONE**

Agent wanted in every town to sell the

**STRICTLY HIGH GRADE**



**\$100.00 BICYCLES**

Write for Catalogue and Agents' Terms.

Send 10 Cents for Elgin King Scarf Pin.

Address Department B,

**ELGIN CYCLE CO.,**  
 ELGIN, ILL.

**Shape of Jewel Holes.**—The jewel holes must be round, smooth, and not larger than are requisite for the free motion of the pivot, which is surrounded with oil. Their sides must be parallel to those of the pivots, so that they sustain the pressure of the pivot equally at all points of their length. The holes, if of brass or gold, must have been hammered sufficiently hard, so that the pores of the metal are closed to prevent too rapid a wear. It is well if the oil sinks are of a size to accommodate a sufficient quantity of oil, which, if too little, would soon dry out or become thickened with the worn-off particles of the metal. The underturning of the pinion leaves are conical, but in such a way that the thickest part is nearest to the pivot, because by this disposition the oil is retained at the pivot by attraction and does not seek to spread into the pinion leaves, as is often the case, especially with flat watches, in which this provision is frequently slighted.



**Chicago as a Jewelers' Headquarters for Bicycles.**

CHICAGO, Ill., July 3.—While as yet the adoption of the bicycle business as a department for jewelry stores has not generally been carried into effect in Chicago, there seems no good reason why it should not become an established part of the trade. Those who have added bicycles to their stocks give many good reasons for doing so, and express satisfaction with the step taken. A special feature to which they call attention is the fact that the season for wheels is at its floodtide at a time when little is doing in jewelry lines; and when one's entire time is taken up with jewelry—as during the holiday season—the bicycles require no time, as there is then no demand for them.

The person who rides a wheel must have a watch; the ladies require belts, buckles and waist sets, and what more natural than that they should be purchased where the wheel is bought; and thus the jeweler not alone makes a profit on the wheel but the buyer becomes identified with his store and the jeweler secures a regular customer for other articles.

Foreseeing the time when the bicycle will be handled by many jewelers, a number of Chicago's prominent jobbers have given the subject attention, with the result that the sale of wheels has become a prominent part of their Spring work. There is a tendency, fight against it as one will, toward a decrease in Spring jewelry sales, and in still

further decreasing them the bicycle is destined to play no small part, thus curtailing the trade of a season and throwing the heavy demand into the few months preceding the Winter holidays.

In the "A. C. Becken Specials" the house of A. C. Becken places its name on a wheel that after a careful and experienced mechanical examination Mr. Becken regards as of the highest grade of construction. To the trade the reputation of this house is firmly established and its name stands for honesty and fair dealing. Two years ago in these columns mention was made of the rapid progress of the firm in the jobbing trade of Chicago. The progress thus auspiciously begun has continued since. The extension of the same business principles to the bicycle department—an honest article at an honest price—a high grade wheel sold strictly on its merits—has given A. C. Becken an enviable reputation in this line. There are shown "Becken Special," Model No. 1 (for men); "Becken Special," Model No. 2 (for ladies), "Becken Special," Model No. 3 (for men), and "Becken Special," Model No. 4 (for ladies). The finish is a wine color that is used only on these wheels, the formula for which is a close secret, and efforts of older factories to imitate it have so far proved unavailing. The firm has had printed circulars without the discount stated, which are designed to be given to customers of the retailer, and these may be had by addressing the firm, Columbus Memorial building, southeast corner State and Washington Sts.

M. C. Eppenstein & Co., Champlain building, northwest corner State and Madison Sts., have made a big hit with their Elgin Cycle Co. wheels, of which company Mr. Eppenstein is president. The factory occupies the south end of the Illinois Watch Case Co. building, Elgin, Ill., a vast structure 395 feet long with main part 40 feet, and wings 30 feet wide, three and four stories high, and fully equipped with every facility devised for the perfect making of strictly high grade wheels. The firm show the "Elgin King," "Elgin Queen," "Elgin Prince," "Elgin Princess," and the "Elgin Double Diamond Tandem"—a truly royal line of wheels. The "Special" weighs but 18 lbs.; King, 22 1-2; Queen, 21; Prince, 22 1-2; Princess, 21, and Tandem, 38. All frames are of Mannesmann seamless, cold drawn steel tubing, and the spokes are of finest quality of piano wire made by the Excelsior Needle Co. All bearings are made of Jessop tool steel, tempered, ground and polished at the the Elgin factory, and absolutely true. The sprocket wheels are drop forged and detachable, constructed so that they can be removed to change the gear without taking off the pedals. In finishes the "Special" is in maroon; the King and Queen in royal blue striped with gold; the Prince and Princess in black striped with gold; with other color enamels optional. The improved crank hanger used is so constructed that it entirely dispenses with the old style of lock-nut and washer and instead the crank is brought close to the hanger.



Weight, 23 to 25 pounds.

BECKEN'S SPECIAL, MODEL No. 1.

Price, \$96.00.

**You Know**

Our A1 standing in the jewelry business, and our enviable reputation for square dealing : : : :

It is the same in our Bicycle business. We offer the best goods at an honest price. Not at cost, as some say they do, but at a small profit. : : :

Every Wheel Fully  
Guaranteed . . . .

**STRICTLY HIGH GRADE WHEELS.**

For Specifications, write for our circular. Will also send advertising matter for distribution among your customers.

Becken's Special, Model No. 1, 1 1/2 inch tubing, . price, \$96.00  
Ladies' Wheel, Becken's Special, Model No. 2,  
1 1/2 inch tubing, . . . . . 96.00

The Becken, Model No. 3 (same as No. 1, one-inch tubing) . . . . . price, \$80.00  
Ladies' Wheel, The Becken, Model No. 4 (same as No. 2, one-inch tubing) . . . . . " 80.00

Write for our Liberal Discounts,

**A. C. BECKEN,**

THE CHICAGO WHOLESALE JEWELER.

Columbus Memorial Building, 103 STATE STREET, CHICAGO.

# The "Safety Case" FOR Riding Specs.

SOMETHING NEW . . . .

THIS INGENUOUSLY MADE CASE FILLS A LONG FELT WANT. IT IS STRONG, COMPACT, DURABLE AND CONVENIENT.

Ask Your Jobber for Them.

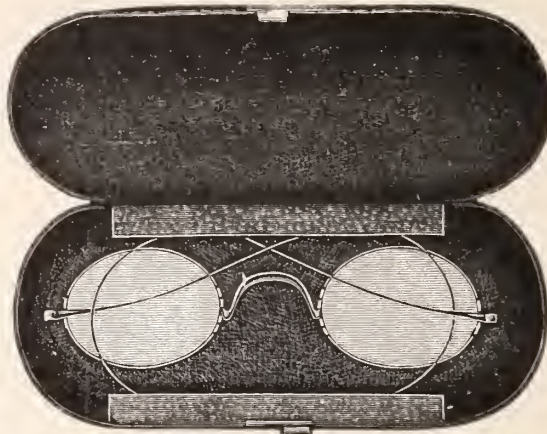

(PATENT APPLIED FOR.)

OUR REGULAR "SAFETY CASE," OF SIMILAR PATTERN, BUT SMALLER, IS THE BEST CASE EVER MADE FOR FRAMELESS, OFFSET EYEGLASSES.

For Sale by all Jobbers

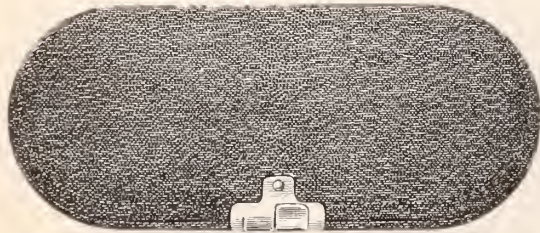

**SUSSFELD, LORSCH & CO.,**

37 and 39 Maiden Lane, N. Y.

## THE SPENCER OPTICAL INSTITUTE

OUR STUDENTS ARE THE SUCCESSFUL OPTICIANS.

OUR COURSE.

PRACTICAL,  
COMPREHENSIVE,  
NON-CLASSICAL.



YOUR GAIN.

KNOWLEDGE,  
PRACTICE,  
WEALTH.

SPENCER OPTICAL MANUFACTURING CO., 15 Maiden Lane, N. Y.

Made by Merritt Gargill & Co. Springfield, Mass.

**COMFORT AND SECURITY ARE COMBINED IN MERRITT'S PATENT EYE GLASS HOLDERS.**

GOODS ON APPROVAL. CORRESPONDENCE SOLICITED.

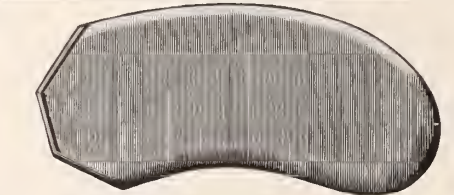

WHITE'S EYE SHADE.



**W. B. WHITE & SON,**

90 South St., Boston,

MANUFACTURERS OF

**Spectacle and Eye-Glass Cases**

White's Adjustable Eye Shades, and Specialties in Fancy Leather Goods, Etc.

LARGE STOCK OF CASES ALWAYS ON HAND.

**Fox & Stendicke,**

Manufacturing Opticians,

61 Fulton St., New York.

Javal, Schiötz Ophthalmometers, Phorometers, Skiascopic Appartus, etc., etc.

Send for Price List.

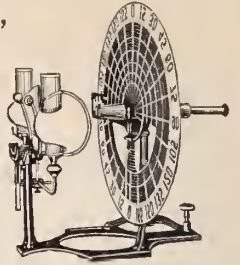

FOR RELIABLE OPTICAL WORK

SEND TO

JOS. FRIEDLANDER & BRO.,  
OPTICAL LENS GRINDERS,  
9 MAIDEN LANE, - - NEW YORK

SEND FOR DESCRIPTIVE CIRCULAR OF OUR FRAME AND LENS CABINET.

## Optical Books.

Any book pertaining to the subject of ophthalmology can be obtained through the Jewelers' Circular Publishing Company. Send for new catalogue just issued. It is free.

## DR. KNOWLES' PRIVATE COURSE IN OPTICS.

Lectures with Diploma \$25.00

Those who desire to study with the Doctor will send in their application.

Students received at any time.

CORRESPONDENCE COURSE PERFECTED.

*The Key to the Study of Refraction.*

50c. per copy,

For Sale by

**R. H. KNOWLES, M. D.,**  
189 Broadway, NEW YORK  
Care of JEWELERS' CIRCULAR.

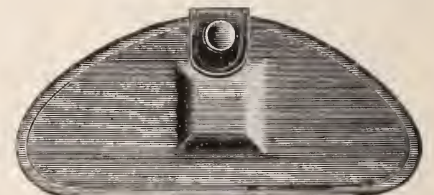

EXTRA THIN.



IN TWO SIZES.

## KOENEN'S NEW SHELL CASE

FOR OFFSET EYEGLASSES.

THE LATEST AND BEST. THIN AND STRONG.

Manufactured and Patented by

**A. KOENEN & BRO.,** 81 Nassau St., N. Y.

SOLD BY JOBBING TRADE.



**The STATIONERS' ENGRAVING CO.,**

98 TO 102 NASSAU STREET, NEW YORK.

MAKERS OF

WEDDING INVITATIONS, RECEPTION AND VISITING CARDS

of the Best Quality, which are offered to Jewelers of recognized standing only.

Trade Mark "SILVER WHITE," registered.

# OPTICAL DEPARTMENT.

## Ocular Refraction

AS RELATES TO THE CORRECTION OF VISUAL DEFECTS \*

BY R. H. KNOWLES, M. D.

**NOTE.**—The purpose of this series of articles is to give to the student without his having had any previous technical education, a clear and practical course of instruction in optics with its application to the fitting of glasses. The Correspondence Column is open to all readers of THE JEWELERS' CIRCULAR. All questions asked will be fully answered.

XXXVI.

(Commenced Feb. 27, 1895.)

### CHAPTER VIII.

#### PHOROMETRY.

**T**he phorometer is an instrument the purpose of which is to measure the relative strength of the muscles controlling the movements of the eye, and it should be found in the office of all refractionists. There are several kinds of phorometers in favor, among them being Wilson's, Prentice's and the Stevens' instruments, the value of each being in the order named.

The Wilson instrument contains all the good points in the others, and in addition has several features peculiar to itself. As this instrument contains everything necessary,

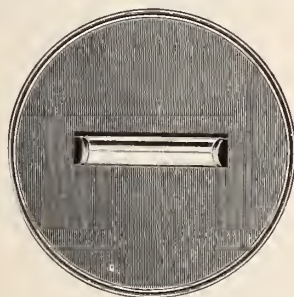

MADDOX SINGLE ROD.

and as with it the tests can be carried out to a hair-like nicety, we will dwell upon this one to the exclusion of the others.

The instrument consists of two discs; the one contains two rotary prisms and the other

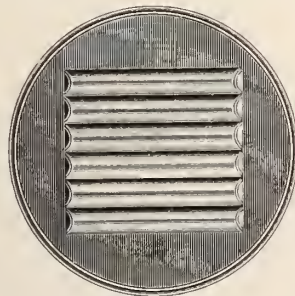

MADDOX MULTIPLE ROD.

the several prisms, double prisms and a cylinder of about 16 diopters convex, essentially the same thing as the Maddox glass rod. The equalizing bar and upright rod constitute the remaining part of the instrument.

The tests which may be made with this instrument are the Stevens or the Graeffe, the Prentice, the Savage and the Maddox double prism and the Maddox cylindrical or glass rod tests.

It would be useless to enter into the details

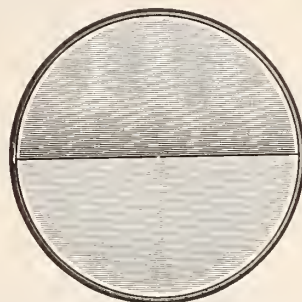

MADDOX DOUBLE PRISM.

of the foregoing tests for muscular insufficiency without first understanding the subject for which these several comparative tests are indicated. This much, however, may be said: that errors of refraction constitute a cause. It is not only necessary to test vision by means of the trial-case but an ophthalmoscopic test should also be made, then the comparative tests by means of the phorometer should be made in order to know what relations exist between the errors of refraction and the muscles which control the movements of the eye.

By referring to the series of articles preceding this series an understanding of the subject may be had, so that the value of instrumental tests can be relatively appreciated. An idea seems to prevail among the majority of refractionists that the phorometer is chiefly employed with a view of prescribing prisms. This is not only a serious fallacy, but the object of this instrument is rather to know when not to employ prisms.

Muscular tests should always be made at the time when vision is taken and a complete record should be made of every case so that valuable advice can be given and a reference for use should future occasion require the same.

(To be continued)

### Friction.

**F**RICITION is defined to be the resistance experienced when one hard body is rubbed upon another, caused by the tendency of the asperities which exist on all surfaces, however highly polished, to interlock together with the natural attraction which bodies have for each other, and possibly some electric action. The force necessary to overcome friction varies directly as the weight or pressure with which the bodies are kept in contact, and is independent of the amount of surface over which the weight or pressure is spread. If the surfaces are too small in proportion to the pressure they will be rapidly

worn away, and if the disproportion be very great, one or both of the surfaces will be destroyed by abrasion.

With most substances used for the acting surfaces of machines this abrading action would very quickly develop itself were the surface allowed to come into absolute contact; therefore, a film of some lubricant is interposed, which, of itself, has a retarding influence; but in machines of any size or weight the amount is very small, compared with the friction proper—the attrition of the metallic surfaces. The viscosity of the unguent employed is also proportioned to some extent to the weight, but it is possible to have the weight so small that, even with the most fluid unguent, the adhesion of the unguent is far greater in amount than the attrition of the metallic surfaces. In the balance-staff pivots of a watch, for instance, there can hardly be said to be friction at all. Nearly the whole of the resistance arises from the adhesion of the oil, the amount of which is exactly proportionate to the extent of the surfaces in contact, instead of to the weight; and as the fluidity of the oil cannot be kept constant, owing to the action of the metallic surfaces and the atmosphere, the varying sum of the resistance is a source of great perplexity to watchmakers. The surfaces in contact are, therefore, wisely made very small in cases where the greater part of the resistance arises from the adhesion of the oil. Toward the barrel, where the pressure is greater, larger surfaces are desirable, and a thicker oil should be used.

When very thin oil, which is proper for the escapement, is used to the center and fusee pivots one often hears of complaints of these pivots becoming dry and cutting. In clocks, the barrels and train pivot holes are often improperly reduced to nearly the same lengths at the verge and escape holes. Where extra surface is desired for the bearings of arbors, etc., it should be obtained by increasing the length and not the diameter, for if the diameter of a pivot or bearing of any kind is doubled the resistance to motion is doubled also, because the revolving surface is then twice the distance from the center of motion.

**Colored Alloy.**—Generally speaking alloys have the same color as the principal metal; this does not hold good always, especially with aluminium. Two chemists recently prepared an alloy with 78 parts gold and 22 parts aluminium, of a handsome purple color with ruby reflex.

**Examining a Watch.**—When taking a watch down, after having taken off the dial, observe whether anything stands higher than the plate. The screw, barrel arbor, and stop-work of low grade watches are invariably higher than they should be and the touching on the dial of the movable parts, such as the minute pinion and the the stopwork, often causes the watch to stop. The pressure of the screw-heads at ends, and barrel arbor against the dial is apt to cause this to break.

## MATTERS IN JEWELRY STOREKEEPING.

That this department shall prove mutually beneficial to our readers, it is desirable that the members of the trade generally communicate with THE CIRCULAR regarding any advantageous device or plan that they are utilizing in connection with their business.

### A Lilliputian Wedding in the Window.

**A**N attractive window display was that recently of R. Siedle & Sons, 254 Fifth Ave., Pittsburgh, Pa., which represented a Lilliputian wedding party. The display was in one of the small windows of the store, measuring about 45x15 inches. The engraving herewith is produced from a photograph of the display, which was taken from the window and rearranged just as it had appeared therein. The central figures were a

that cartoons do in a political way to newspapers. He said that it was his belief that one illustration, well thought out and executed, will convince more than columns of argument in words. Beside a good cut it is necessary to have an interesting story to go with it; in other words, the cut should be a part of the story. On the other hand the story must be as good as the cut; a good cut with a poor advertising story is only half a good ad.; the man who designs the cut should also design the story to go with it.



LILLIPUTIAN WEDDING.—WINDOW OF R. SIEDLE & SONS, PITTSBURGH, PA.

doll bride, bridegroom and minister, all in the regulation bridal attire. Above the heads of the party was a sign, which read "We furnish the rings." In front of the group was an extensive display of wedding rings in cases. The whole display proved to be unique and attracted the attention and interest of numerous passers-by.

### Advertising Cuts and Windows.

**A** WELL-KNOWN advertising man and window dresser for a large western house, in a recent interview, gave many practical hints as to the best way to advertise a retail store in the newspapers. The best method, he said, is to get up new ideas in a pictorial way, which will prove attractive and different from those of any other advertiser. Pictures in ads. bear the same relation to retail stores

"I believe in taking enough space for ads. to tell what I have to say, and to cut the space to fit the ad., not the ad. to fit the space, and in keeping with the business-endeavoring to be done. An ad. should never have a crowded appearance. White space judiciously used is well used."

In advertising an exclusive retail store, such as a jewelry store, he asserts that the best way is to elaborate upon the quality of the goods more than simply putting in a few low prices as leaders and bait. He thinks it is better to give a reader some idea of the kind of goods that the store contains and to submit it to their judgment to call and see for themselves that the goods are as advertised.

The advertisement should be a bright, entertaining, amusing, newsy invitation to come to the store. In designing [advertisements,

the window display should receive careful thought and consideration. Good window displays should supplement current ads. If the latest goods predominate in your ad. they should also predominate in your windows, and the more attractive and artistic the window is the more passing trade you will get, the better advertised will be the store and the goods.

### Poetry in Local Puffs.

**T**HE following from the Mt. Sterling, Ky., *Advocate*, are unique local puffs which are adaptable to any jeweler's store:

"THE LEADING JEWELRY HOUSE of central Kentucky was established over twenty-one years ago. It carries a most complete stock of clocks, watches, diamonds, jewelry, etc., and is to be found on Main St. Yes:—

This is the place for trading fair,  
In gold, diamonds, or silverware,  
Watches, brooches, bracelets, rings,  
And other costly, brilliant, things  
Of rare design and grand display,  
They seem to mock the orb of day.

"Mr. J. W. Jones, that social and genial gentleman, is the proprietor. His name carries a power of strength with it, and when coupled with the jewelry business means reliability, correct representation, and honest goods for honest money. He makes a specialty of repairing fine and complicated watches and jewelry mounts, and sets diamonds, and does all kinds of engraving. All of his goods are sold under a strict guarantee to be just as represented, and his prices are the very lowest."

C. C. FREEMAN:

"Watches, clocks and jewelry on Main St. He has been established for one year, and in that short space of time has secured a name and fame as a practical repairer and honorable dealer that any one might be proud of.

Now, if your watch or clock won't run,  
You have had it fixed galore,  
Until disgusted you declare,  
You'll have it fixed no more,  
Give C. C. Freeman a chance;  
Take it to his shop,  
He will guarantee to make it run,  
Keep time and never stop.

"Mr. Freeman handles a large line of jewelry, watches with the world's best movement, diamonds, silverware and fancy goods, all at bottom prices."

### To Clean Windows.

**C**HOOOSE a dull day, or at least a time when the sun is not shining on the window, as when the sun shines on the window it causes it to be dry-streaked, no matter how much it is rubbed. Take a painter's brush and dust them inside and out, washing all the woodwork inside before touching the glass. The latter must be washed simply in warm water diluted with ammonia. Do not use soap. Use a small cloth with a pointed stick to get the dust out of the corners; wipe dry with a soft piece of cloth. Do not use linen, as it makes the glass linty when dry. Polish with tissue paper or old newspapers. This can be done in half the time taken where soap is used, and the result will be brighter windows.—*Montreal Pharmaceutical Journal*.



# TRADE-MARKS OF THE JEWELRY AND KINDRED TRADES.

Copyright, 1896, by The Jewelers' Circular Pub. Co., 189 Broadway, New York.

A  
Jewelers'  
Necessity

For eight months THE JEWELERS' CIRCULAR has had under way a work that will comprise the trade-marks of every branch of the Jewelry, Watch, Clock, Silverware, Silver Plated Ware, Optical Goods, Precious Stone, Art Pottery, Bric-à-brac, Cut Glass and cognate lines of the Jewelry Industry.

The work is now nearing completion. We consider it will be the most valuable book that has ever been issued to the Jewelry trade.

It is a work which the retailer and wholesaler will immediately appreciate.

It will be a book of constant reference, and will be consulted more perhaps than any other book issued to the trade.

It will be a book of daily use.

It will be sold at a figure that will guarantee its rapid distribution.

In addition to illustrations of the various trade-marks and the names and the addresses of the firms to whom they belong, and the class of goods to which they appertain, the work will contain other interesting and valuable information bearing upon the subject of trade-marks.

Members of the Trade, Manufacturers, Wholesalers and Retailers should at once place their orders for

**"TRADE-MARKS OF THE JEWELRY AND KINDRED TRADES."**

\$1 per copy. Bound in Cloth. Payable now or upon delivery of Book. Detach order below and forward to the Jewelers' Circular Publishing Co., 189 Broadway, New York.

Those firms who have as yet not sent electrotype, print or drawing of their trade-mark or trade-marks are requested to do so at the earliest possible moment.

**ADVANCE ORDER BLANK.**

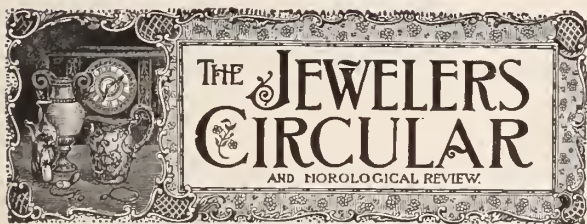

189 Broadway, New York.

..... 1896

Please file this order for ..... copy of

"Trade-Marks of the Jewelry and Kindred Trades"

for which I agree to pay \$1.00 per copy, postage prepaid, upon delivery of book.

Name .....

Street..... City..... State.....

## A Few Modern Tower Clocks.

[From the *Deutsche Uhrmacher Zeitung*.]

IN Paris, at the foot of the well known hill Montmartre, is one of those immense bazars, several of which have flourished already for a number of years in the elegant capital of France, with its countless hosts of daily visitors from all parts of the globe it is known as the "Maison Dufayel";\* the front of the building is ornamented by a large tower,

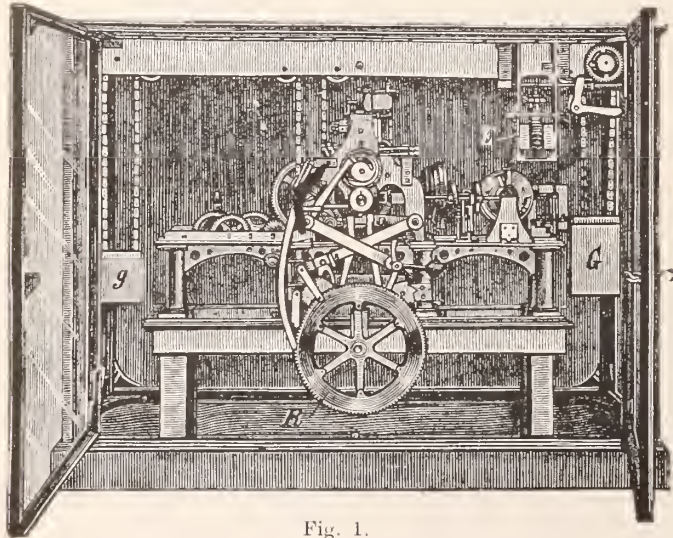

Fig. 1.

with electric arc lamps which at night send their illumination into the far distance. The tower clock is a masterpiece of modern horology. Another still more interesting clock stands in the interior of the building—at the foot of the large staircase. We compile the following article from an interesting account in *La Nature*:

The tower clock has four dials in the gable of the front of the building. The central dial has a diameter of three meters (1 meter = 39.37 inches) and indicates the hours and minutes. The three other dials are only half as large; the left one shows the barometric heights, that to the right the lunar phases, while the last, above the principal dial, indicates day and date. It is for this purpose furnished with three concentric hands, of different lengths, of which the smallest shows the week day, the second the month, and the largest the date. The motion of these hands is automatically regulated by a suitably calculated and arranged movement.

Fig. 1 is a rear view of the going train as seen from the back, and was constructed by the Paris watchmaker, Chateau. As the disposable place was contracted the clock movement could be constructed in proportionately small dimensions only. The pendulum is only about 865 millimeters long. The only weight, hanging on a strong kind of fusee chain, has a falling height of only 800 millimeters. The endless chain is passed over a number of rolls to the left, and is then kept in necessary tension by a counterweight *g*. So soon as the

weight *G* has approached the bottom of the clock chamber within a few millimeters, it closes an electrical contact, which then forthwith actuates the small electric motor *E*. This small dynamic machine then winds up the run-down weight, until it abuts above on a second contact, which interrupts the electrical current again. The electric motor is simply connected with the conduit that furnishes the electric light of the building; in its lowest position the weight cuts the current

in, in the highest it actuates the cutting-out arrangement.

Fig. 2 represents the mechanism of the striking train in the left half of the illustration, where the large drum is visible. The smaller drum to the right belongs to the chime of bells, which is unlocked by a pressure upon a button, and the hammers of which play several pieces automatically by the revolution of the drum.

The clock train can be recognized quite distinctly in the illustration. In the upper part of the central piece is visible a fusee disc, which actuates upon a lever leading to the great wheel *R*. This is the actuating arrangement for the date train, the hands of which are concentric with the wheel *R*. The striking trains are located in the cupola of the clock tower. They act upon ten bells freely suspended in a circle. The quarters are chimed by a melody divided into four parts, of which the first part is sounded in the first quarter, the second in the second, etc. At the full hour, the four parts of the melody are played first, after which the hour strokes are struck in simple tones. The striking train is unlocked by electrical contacts, which are closed by the going train.

But beside this, there is a small keyboard of ten keys underneath the drum of the bell-chime, by which the bells may be sounded by a musician. The winding of the striking train as well as of the chime of bells is automatically effected by electricity. The electric motor can be seen below to the right in Fig. 2.

Several discs and rolls will be seen on the half of the going train to the right, which look almost like a small lathe. It is an in-

geniously conceived and novel apparatus by which the indications of an ordinary aneroid barometer are transferred to the above mentioned dial,  $1\frac{1}{2}$  meters large, on the exterior of the building. This transport is effected by electricity in the most perfect manner. The contrivance of this apparatus, contrary to the hitherto usual arrangements of a similar kind, in which the statement is effected by an index direct on the barometer tube, is of such a kind that the size of the dial reproduced is entirely unlimited.

The movements mentioned up to now were constructed new by the firm, Chateau. The calendar clock represented in Fig. 3, however, in the staircase house of the building, is somewhat older, and passed through remarkable fortunes to be recited hereafter. Let us first look at the technical arrangement of this peculiar work of art which was named "chronologometer" by its constructor, the celebrated Paris watchmaker, Wagner. All the wheels of this movement, which is corrected automatically by electricity each day by the tower clock, Fig. 1, are placed upon a strong steel pillar, which imparts to the movement a peculiar appearance, that attracts attention still more than the numerous single parts.

The actual going train with the escapement and pendulum is on the side turned away from the examiner, therefore behind the center pillar. The rope of the weight as well as the block and fall are hidden in the hollow pillar, and the weight in its fall moves within a hollow in the foot.

The movement actuates first the two hands of the small dial which is close above the en-

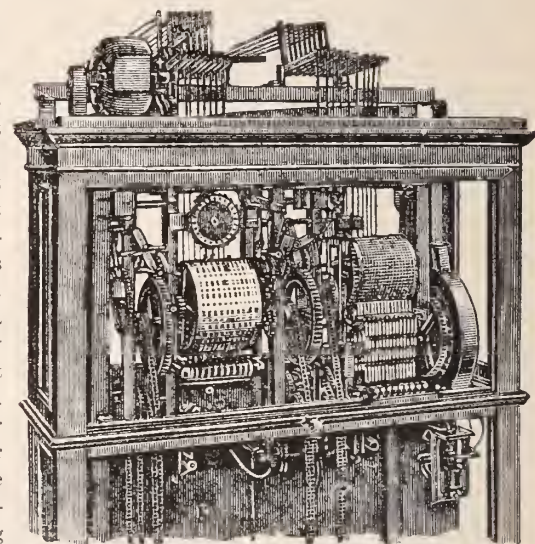

Fig. 2.

circling rod to protect the glass sides of the case. One hand, visible through a round hole, indicates stellar time; the other hand, mean solar time. The difference of the two hands is effected in such a way that the former is mounted upon a wheel of 365 teeth, the second upon one of 366; these two wheels

\*It carries on an immense business on the instalment plan, and had, in 1895, 883,000 "abonnés" on its books; beside this, it sells for cash. —NOTE BY ED.

are revolved by the same pinion. The hours of the mean solar time are thereby changed into the shorter stellar hours.

Behind the dial is visible a horizontal rim from which may be learned the present day of the week. Above it, occupying the center of the clock, is the actual calendar, in the center of which is the sun in the shape of a large sphere. The dial rim is divided into 365 parts. (In each leap year the hand must at the 29th of February be set back one day.) The dial rim consists of three concentric zones, of which the outer and inner are immovable, while the central may, by means of a button, be displaced by an angle inclosing seven days. Upon the inner rim are engraved the 365 days of the year, together with the ecclesiastical feast days; the outer has the names of the months, while the division of the central movable rim shows the name of the week days. In every year, on April 14, the latter are displaced in such a way that Easter comes together with the day on which it occurs.

Immediately connected with this triple rim will be seen to the left above and the right below, two opposite lying small dials, which revolve once annually around the sun and at the same time around themselves, for which purpose they gear with suitable pinions into a large stationary wheel. The dial visible above to the left carries in its center the earth with its axis inclined  $23^{\circ} 27'$  toward its path of revolution. In consequence of the just now described mechanism it makes one revolution around its axis in 24 hours, and another around the sun in 365 days.

Around the earth revolves at the same time, at an inclination of  $5^{\circ}, 08' 47''$ , the moon with a speed corresponding to actuality, so that the eclipses always take place on their true days. At the same time the hand on the dial rim indicates the days of age of their satellite. The system of the revolutions of the earth and moon are exceedingly complicated. Mr. Chateau made an entirely new mechanism, because the old showed several errors of construction and calculation.

The small dial to the right below is divided into lunar months according to the rules of the Mohammedan calendar—one of 29 days alternating with one of 30. The date is shown by a prolongation of the large hand on the central (main) dial, which concurs in the movement around the sun. This prolongation is fastened in the center of the lunar months' dial and here forms a pivot around which the latter revolves. The revolution of this small dial around its own axis takes place in the same manner as with the mechanism of the earth; it rolls, so to say, along on the periphery of the stationary toothed wheel.

Above the central calendar movement will be seen a large wheel which carries a small disc, and behind it a pale dial rim, above which is a second small disc of equal size. The wheel makes one revolution in four years, while the dial rim accomplishes one in 28 years. From this follows that in every leap year the small disc of the large wheel stands truly vertical under the upper disc. Exactly

between the two discs there stands upon the dial the week day on which the 29th of February falls. Of the two discs, the lower is furnished with a small hand, and the word "leap year," the upper with "February 29."

The clock movement, the wheels of which revolve slow and slower the higher they are situated, is continued on the other side of the central column, where it revolves the hand of the large backward showing dial A, which contain in four spiral coils the 400 year figures from 1,600 to 2,000, and which therefore turns once around its axis in a century.

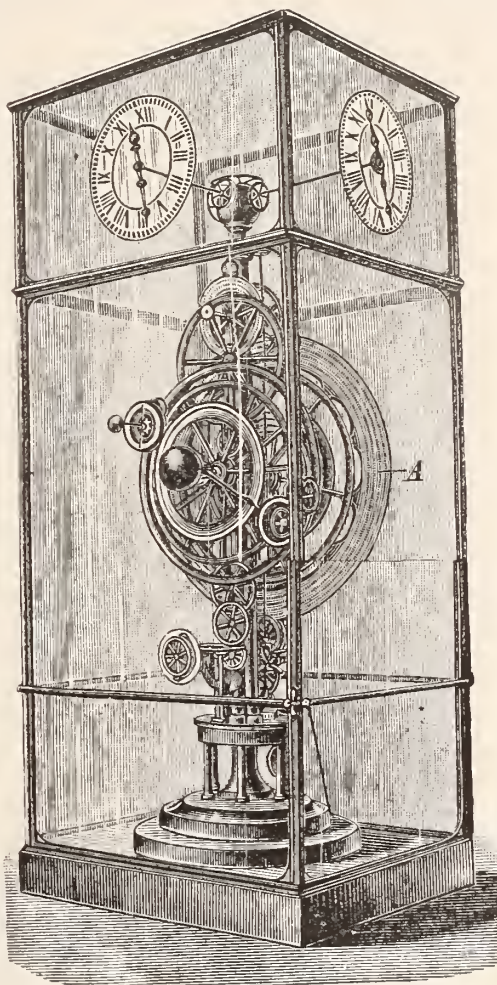

Fig. 3.

This hand is composed of two parts sliding one upon the other; the outer movable part is continually pushed out by a projection gearing into a deepened spiral winding, so that the hand lengthens gradually, whereby its point shows always upon the proper century coil. Each of the year figures is composed of four single numbers engraved upon copper tablets and fastened to the division circle by means of a screw and nut. In the year 2,000 this tablet may be taken off and a new series of 400 year figures formed by interchanging and renewing, without altering anything on the mechanism. Besides the 400 year figures the division circle also carries 4,800 month indications and 4,800 day indications. The space occupied by each year figure is divided

into 12 parts, each of which contains the name of a month and number of days.

Behind this division circle is finally still another large rim divided into 40 parts; each division contains the requisite indications for one century (from 1,600 to 5,600) for the reconstruction of the just now described century dial. This rim revolves in 4,000 years (!) once around its axis, so that its fixed hand always points to the correct date of the current century.\*

As will be seen from Fig. 3, the entire movement is located in a large casing of heavy glass, on the upper part of which three ordinary dials (front and two sides) indicate the time.

By considering the work of engraving the various parts of this marvelous piece of mechanism, it will be found the different dials contain more than 15,000 statements, composed of about 25,000 words, and nearly 100,000 letters of figures engraved upon copper.

This clock was conceived and commenced by Wagner, who called it "chronologometer." After his death his successor, Collin, completed and set it up in the *Grand Café Parisien*, on the site of the present labor bourse, but which suspended about 15 years ago. Although the age of the chronologometer does not extend beyond a few decades, it has had a truly eventful history. After the suspension of the *Café Parisien*, the movement was taken down and taken to the world-renowned pawnshop, Mont-de-Piété. Here it remained until last year, when it was finally sold. It was naturally in a pitiful state, and its restoration consumed much time and trouble, as Mr. Chateau was compelled, as already stated, to reconstruct a part of the planet wheels, which had been calculated wrongly.

THE CIRCULAR rejoices to state, however, that for the last several months the clock performs excellently; especially the electrical transport of the barometer to the exterior dial could not be more perfect, and the system will no doubt be used also for other purposes.

**Concerning Adjustment.**—Mr. Potter, of Geneva, Switzerland, says that to adjust very closely all watches of high grade is possible, but not practical, because the labor, time, and consequent cost would never be paid for. Taking the watches as they are made, one with the other (though all of a high grade if you like), we are more or less in the same boat, at the mercy of wind and tide. Even the most learned and experienced are mere children in the art. Adjustment to temperature, isochronism, together with flat and hanging, is fully and completely under the control of any one who wishes to make it; but the correction of errors in all the positions in watches by the quantity is an unknown art. The mysteries involved in it mock our best efforts.

[\* QUERY: Did the constructor of this clock imagine that the work of his hands would successfully resist the wear and tear of the "tooth of time" not to speak of the natural enemies, rust, etc?—The Editor.]



The strength and durability of our patent safety pins, has made it practical for us to freely replace all broken pins returned to us ; but since the market has been flooded with cheap imitations which are constantly breaking, we have been over-run with broken pins (not our make) until the expense, even of returning them, has become a serious matter ; and we hereby inform the trade that we can no longer do this except at the expense of the sender, and request that they look for the patent date on the inside of the pins before sending to us.

B. A. BALLOU & CO.,  
61 Peck Street,  
Providence, R. I.

## MATHEY BROS., MATHEZ & CO.,

Brassus, Switzerland. 21 & 23 Maiden Lane, N. Y.

SOLE AGENTS :

## CHAS. MEYLAN WATCHES.

# SPLITS

A SPECIALTY.

## AMERICAN WATCH TOOL CO.

ESTABLISHED 1872.  
INCORPORATED 1894.

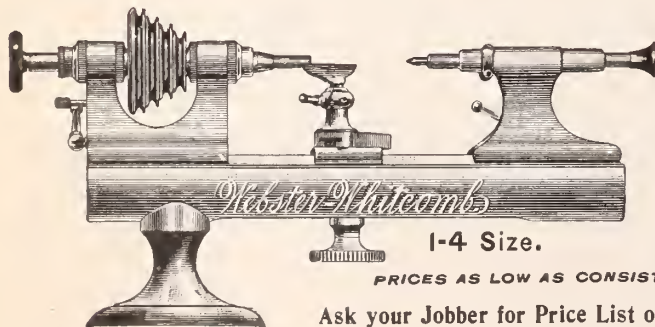

THE  
**Webster-Whitcomb**

1-4 Size.

GROWS IN POPULARITY

PRICES AS LOW AS CONSISTENT WITH QUALITY.

Ask your Jobber for Price List of 1895, or write to us at

Stoney-Batter Works, Chymistry Dist., Waltham, Mass.

ESTABLISHED HALF A CENTURY.

## MARVIN'S FIRE & BURGLAR SAFES

HAVE MANY PATENTED IMPROVEMENTS  
NOT FOUND IN OTHER MAKES  
THAT WILL WELL REPAY AN  
INVESTIGATION  
BY THOSE WHO DESIRE TO SECURE  
THE BEST SAFE  
MARVIN SAFE CO.

12 PARK PLACE, NEW YORK.

## THE SWAN FOUNTAIN PEN

Reputation World Wide.  
Made upon Distinct Principles.  
Is a Compressed Air Pump.  
Simply Wet the Insides to Provoke  
an Energy.

W. W. Stewart, Inventor and Patentee.

A variety of Styles and Prices

- 3 Sizes Safety Swans.
- 3 Sizes Self-filling Swans.
- 3 Sizes Adjustable Feed Swans.

## MABIE, TODD & BARD,

NEW YORK AND LONDON.

O. NEWMAN,  
Gold and Silver Electro-Plater,  
Etruscan Coloring a Specialty.  
WATCH CASE POLISHING.

75 Nassau St., Room 8 Rear Building, New York.

H. M. RICH & CO.,  
Jewelry - Auctioneers,  
21 School Street,  
BOSTON, MASS.

QUICK SELLERS.....  
IN STERLING SILVER  
ARE MADE BY  
CODDING BROS. & HEILBORN,  
North Attleboro, Mass.





## The Rambler's Notes.

WHAT THE RAMBLER SAW AND HEARD AMONG THE DEALERS IN ART POTTERY, CUT GLASS, BRONZES, ETC.

**THE COMING POPULARITY OF FINE ENGLISH POTTERY.**

THE impression seems to prevail among certain large importers of fine china, that English wares, particularly such lines as Doulton, Crown Derby and Royal Worcester, will have the call this Fall. The manager of one large importing house whom a CIRCULAR representative saw, said that there was no doubt that Royal Worcester and similar goods will be in great demand next season; in support of this statement he instanced some large orders which the English factories have received. One for Royal Worcester goods given by a single firm amounted to many thousands of dollars, which was larger than this firm had ever before given even in Royal Worcester's most popular days.

**NEW HALL CLOCKS.**

SOME pleasing effects in hall clock cases may be seen in the store of the Charles Jacques Clock Co., 22 Cortlandt St., New York. The variety of these cases is very large, and the decorations in many are entirely new and original and are controlled by this company. In quality, also, there is to be found a wide range from the moderate priced to the richest and most expensive variety of cases on the market. The cases are fitted with Elliot movements chiming on gongs and bells.

**CATALOGUE OF ARTISTIC LAMPS.**

THE catalogue of the new general lines of decorated glass lamps made by the Phoenix Glass Co., is one of the finest volumes of color printing which has ever come into the trade. All of the company's new banquet, library and princess lamps, as well as their decorated glass globes, are here depicted in all their shades and colorings. The catalogue consists of about 20 sheets of heavy paper, 11x15 inches, each sheet showing from two to six lamps or nine globes. The volume may be obtained by jewelers who will apply either to the company's office, 46

Sixth Ave., Pittsburgh, Pa., or to their New York salesrooms, 42 Murray St.

**ORIENTAL AND SPANISH DANCING GIRLS.**

SOME of the latest products of the Art China Decorating Co., shown by Levy, Dreyfus & Co., 11 Maiden Lane, New York, include large plaques artistically-hand painted. The subjects show Oriental and Spanish dancing girls depicted with all the colorings of their native costumes. A full line of plates now appears decorated with figures and groups of French and Spanish girls and men.

THE RAMBLER.

## Decorated Glassware of Bohemia.

IT can but add to the appreciation of the ornamental glassware from this mountain country to know something of its production. The materials are found in this part of Austria in abundance, and the heavy growth of timber affords the best of fuel for glass making.

Driving over the perfect roads, lined with evergreen trees, winding over hills, beside the mountain streams, descending to the valleys, little hamlets enliven the scene with quaint church towers, houses with odd gables, thatched roofs, irregular in arrangement, clustered together formerly for mutual protection and now for the social intercourse and convenience of its inhabitants, especially during the long Winter months. Along the main street on either side are seen pretentious buildings. These are the warehouses where is received the beautiful ruby, rose, emerald, amber and crystal glass forms from the distant factories.

The skilful glass blower has, as the result of years of practice, learned his art. Watch one of these men gather a bulb of glass on the end of the blow-pipe with scarcely a glance at the model or outline drawing, reproduce exactly the desired shape, turning, twisting, swinging the long pipe, blowing just enough of air in to expand it, rounding it with a piece of soft wood, shearing off the top while still hot. A touch of the callipers proves it right to a fraction. From the warehouse in the town the shrewd managers drive close bargains for piece work, as may be imagined, and in baskets, women, many of them prematurely

old, bear away on their backs to their homes the glass articles, to decorate with gold, or color, as may be desired.

Men, women and children work when not in the fields, and in every town will be found the art school sustained by public tax, where the hand and eye are early trained; and in this out-of-the-way country, with few natural advantages, the result of even this limited teaching bears fruit in original designs, unique and beautiful. Few strong young men are seen, they are away in the army. It is a sad sight to see the old women, and even little girls, bearing burdens of wood, hay, glass, or supplies, with bended backs, over the mountain roads. Well may the boy feel glad, though his burden be heavy, as he wends his way back to the warehouse, where the decoration is fixed by fire, to receive the money for the labor of the family; a misstep might destroy the work of many days.

There exist, also, many large factories where the peasants labor at glass blowing, cutting, engraving, gilding, and decorating, but could we know the trials, losses and discouragements of both workmen and proprietors from broken, melted and imperfect pieces, we would better appreciate the patience necessary to perfect the common Bohemian chimney, the fine cut and gilded service of table glass, or expensive vase.—*The Ceramic Monthly.*

## Fragments.

Burglar-proof glass has been invented by a Dresden manufacturer. It is made by pouring molten glass over a network of steel wire. It is especially adapted for skylights and jewelers' windows.

In a volume called "On Short Leave to Japan," by Captain Younghusband, he tells us that at a railway station near Nikko they give you a cup of tea for about a penny; *this includes the teapot and teacup.*

Aluminium will mark a glass or "paste" diamond, but not the true gem, provided the surface is wet. This fact has now been applied in the production of a mechanical tester, which consists of a small disc of aluminium, rapidly revolved by an electric motor. The stone to be tested is wetted and held against the edge of the disc by means of a spring clamp.

### Workshop Notes.

**Banking Pins.**—The banking pins have nothing whatever to do with overbanking. They only regulate the run, or, in other words, the distance the pallet jewels travel in toward the escape wheel. If the banking pins are too far apart, the scape teeth reach too far up the locking planes of the pallet jewels, and the balance, therefore, having to carry the fork so great a distance before the scape-wheel teeth act on the impulse planes, meet with so much resistance that the motion is very much decreased and often causes the watch to stop altogether.

**The Banking of the Fork.**—In a correct escapement the fork should bank against the pins immediately when the scape-tooth has dropped from one jewel to the other. If the watch overbanks, the fork is either too short or the roller too small; in most cases, unless the roller has been tampered with, the trouble lies with the fork. Its effective length should be such that, when the power is on the watch, if the guard point of the fork is pressed against the roller, it will, on being released, return to the bankings.

**Size of Fork.**—In no case should the fork be so short that it can be wedged against the roller, as the watch would be liable to stop at any time, and if it received a jar, would, in all probability, start off again, and cause a great deal of trouble in locating the stoppage, in addition to the annoyance to customers.

**To Color Iron and Steel Brown.**—In 4 parts water dissolve 2 parts crystallized chloride of iron, 2 parts chloride of antimony, and a trifle of tannic acid, and apply this moisture with cloth or sponge upon the sur-

face; then let it dry. Repeat the application according to the depth of color desired. This coating fully protects the steel against damages by humidity. The chloride of antimony should be as little acid as possible.

**Blue Springs.**—Mr. Glasgow says that there is no advantage gained by bluing a spring, as it is not thereby kept free from rust. Indeed, it is said that steel, when blued, is in a state of incipient oxidation, and it is known that the blue spring is more frequently found rusted in a ship's chronometer than the bright portion of the escapement.

**Brightening Tarnished Gold.**—The Barcelona *Chronómetro* recommends as a brightener of tarnished gold the following: Place the object in a porcelain or crystal vessel containing the following composition: 80 grains hypochlorite of lime, 80 grains bi-carbonate of soda, and 20 grains table salt, dissolved in one quart water. After an immersion of several minutes, take out the article, wash it, bathe it in alcohol, then dry it in sawdust. The tarnished article will hereby become as bright as new. The preparation may be preserved in a well stoppered bottle.

**To Tighten Cannon Pinion.**—To tighten a cannon, file in the side with a small round file, and punch it until right; tighten the Swiss center arbor, roll it between two files, and oil it slightly when you put it in.

**Repairing Pinion Leaves.**—When pinion leaves are broken, a new pinion is best, but sometimes they can be repaired by placing in a small soft brass and driving it down to the leaves after they are set in position; then soft solder it to the leaves, digging out the solder with a sharp broach; then apply oil so that it will not rust.

### THE BOWL OF ALBEMARLE.

*An Independence Day Legend.*

'T WAS Lady Ashe of Albemarle:  
She heard bold Tarleton boast  
That he the British flag would set  
On every planter's house he met  
On Carolina's coast:  
That, when the Carolinas fell,  
He would return and quaff  
His victory in the honored hall  
Where met the patriots, and call  
On Lady Ashe of Albemarle  
To bring her family beaker out;  
The cavaliers should cheer and shout—  
'T would make old England laugh!  
O Lady Ashe, O Lady Ashe,  
What wilt thou do, where wilt thou be,  
When courtly Tarleton asks of thee  
The bowl of Albemarle?

'T was in the hall of Albemarle;  
The feast was spread they set  
The empty goblets on the board  
Where erst the patriots met.  
The fire upon the oak walls gleamed,  
And on the men looked down  
From green festoons of mistletoe  
With berries white as winter's snow,  
The flag of England's crown.  
Then Tarleton ealed on Lady Ashe  
To bring him in the hall  
The goblet of her family pride,  
The goblet ancient wines had dyed,  
The bowl of Albemarle.  
O Lady Ashe what wilt thou do?  
A patriot's daughter should be true;  
Their flags are red, and thine is blue,  
My dame of Albemarle.

The legend old of Albermarle!  
The oaken door swung wide,  
And Lady Ashe came to the board,  
And Tarleton stood beside.  
She raised the bowl above her head;  
'T was filled with roses. Then—  
"It matches well the red flag!" said  
Gay Tarleton to his men.  
The roses o'er the astrals burned,  
And fragrant grew the air,  
As slowly she the goblet turned  
Above her shining hair.  
Flower after flower, the roses red  
She dropped upon her stately head.  
Their beauty charmed their perfume filled  
The high colonial hall  
As, one by one, my lady spilled  
The blossoms great and small;  
Till empty in her hand she held  
The bowl of Albermarle!

The bowl, the bowl of Albermarle,  
She turned it in the air,  
And here a rose and there a rose  
She spilled upon her hair.  
A prophet's fire then stirred her blood,  
And on the cup once more  
Gazing with flashing eyes, she stood;  
Then smiling in defiant mood  
She dashed it on the floor!  
The startled guard advance apace,  
But stood my lady there,  
The patriot triumph in her face,  
The roses in her hair.  
O Lady Ashe, my Lady Ashe,  
All silent is the hall,  
Thy cheeks are red, the patriots' white,  
And Tarleton's ashen in the light;  
Speak, Dame of Albermarle!

"My gallant general, hear!" she said,  
"We've heard your merry boast,  
That you would line with British flags  
The Carolinian coast,  
And that from our old cup should be  
Your wine of victory spilled;  
My courtly general, thou art weighed,  
For there's one promise thou hast made,  
That on the land or on the sea,  
Can never be fulfilled!"  
In voiceless hall, 'mid staring men,  
Still stood my lady there,  
The patriot glory in her face,  
The roses in her hair!

The broken bowl of Albemarle!  
Life teaches life, and he  
Whose will from self itself has freed,  
A thousand wills may free!  
O Lady Ashe, my Lady Ashe,  
Who heard proud Tarleton boast,  
It is the Rose of Albemarle  
The gallant riders' toast  
Who woke in dawns of dewy morns  
And followed golden peals of horns  
Down Carolina's coast,  
And Freedom's new-born banners set  
On every plauter's house they met!

—H. BUTTERWORTH, in *The Youths' Companion*.

## PATEK, PHILIPPE & CO., GENEVA, SWITZERLAND.

MAKERS IN THE HIGHEST QUALITY OF

### Fine, Plain, Complicated And Decorated Watches

IN 15 DIFFERENT SIZES.

INTERCHANGEABLE PARTS.

NEW YORK OFFICE, 68 NASSAU ST.

ALFRED G. STEIN, Representative.

## SLOAN & COMPANY,

SUCCEEDING

JOHN A. RILEY & SLOAN CO.,

MANUFACTURING JEWELERS,

23 MAIDEN LANE, N. Y.

HAYS BUILDING.

AUGUSTUS K. SLOAN, Pres.  
FRANK T. SLOAN, Vice-Pres.

BENNET OSBORN, Jr., Treas.  
ALLAN A. McDONALD, Sec'y.

## WM. SMITH & CO., 5 and 7 MAIDEN LANE, NEW YORK. 61 PECK ST., PROVIDENCE, R. I.

ESTABLISHED  
1854.



MANUFACTURERS  
OF

### Gold, Silver and Rolled Plate Chains and Jewelry.

Novelties in Gold and Silver Bead Necklaces and Bracelets. Also a large line of Chain Trimmings and Silver Rings.

A Boston man has a clock which he "thinks would run 10,000 years." Show the clock a Boston girl in bloomers and see—  
Chicago *Dispatch*.

ARE always of **Standard Quality**, of **Newest Styles** and **Best Finish**.

They will always sell when anything will, and cost no more than those of doubtful reputation.

Don't wait for our travelers, but send direct to

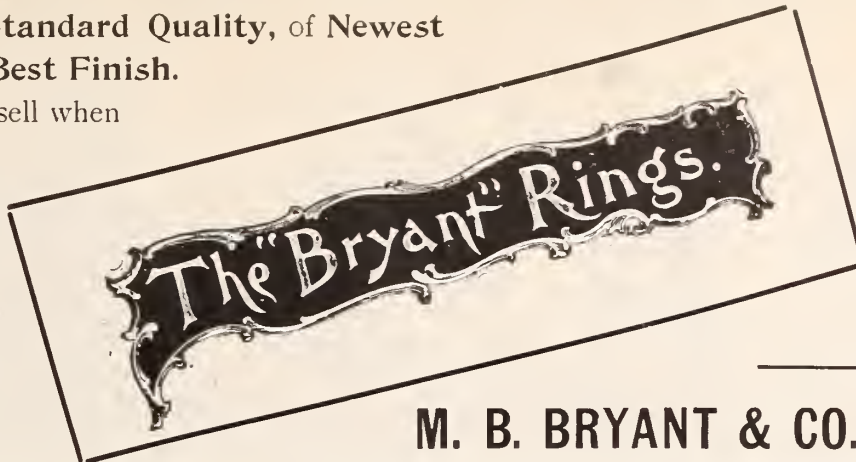

**Oldest Ring Makers in America.**

**M. B. BRYANT & CO.,** 10 Maiden Lane, N. Y.

### NYE'S SUPERFINE OILS.

Special grades for

CHRONOMETERS,  
WATCHES,  
CLOCKS,  
JEWELERS'  
LATHES,  
ETC., ETC.



NYE'S OILS acknowledged SUPERIOR TO ALL OTHERS.

**WM. F. NYE,**  
Manufacturer,  
New Bedford,  
Mass.

We carry the largest, finest and most complete line of Mounted Diamond Jewelry of any house in America.



18 JOHN ST NEW YORK

### KETCHAM & McDOUGALL,

MANUFACTURERS OF

GOLD AND SILVER  
**THIMBLES**

ESTABLISHED 1832.



TRADE-MARK.

And the improved

**Automatic Eye-Glass Reel.**

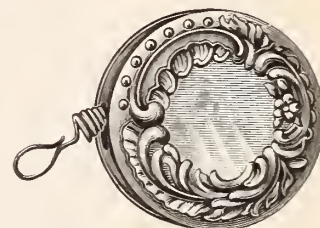

Pat'd Nov. 20, '94.

SEND FOR CATALOGUE.

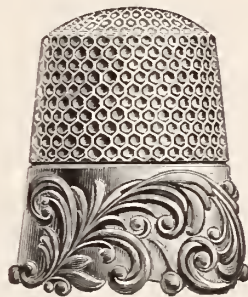

No. 149

198 BROADWAY, NEW YORK.

### SECURITY PIN GUARD

PAT'D DEC. 25, 1894  
MANFD BY SECURITY MFG CO. **25¢**

7 ASTOR HOUSE (BROADWAY) N.Y.

85c. doz. Net Cash. Discount to Jobbers

### JACOT & SON,

Importers and Manufacturers of

**Musical Boxes,**

39 Union Square, New York.

SEND FOR CATALOGUE of books for the jewelry and kindred trades. Just issued. JEWELERS' CIRCULAR PUB. CO., 139 B'way, N. Y.

### AIKIN, LAMBERT & CO.,

MANUFACTURERS OF

FINE GOLD PENS, HOLDERS, PENCILS,  
TOOTH PICKS, and NOVELTIES.

PAUL E. WIRT FOUNTAIN PENS, at new and lower prices . . .  
MERCANTILE FOUNTAIN PENS, guaranteed to give satisfaction.

Catalogues with terms and discounts furnished to the trade.

BRANCH, 103 STATE STREET, - - - CHICAGO.

19 MAIDEN LANE, NEW YORK.

### AIKIN-LAMBERT JEWELRY CO.,

IMPORTERS OF

**DIAMONDS.**

JOBBERS IN

**WATCHES, JEWELRY, CHAINS  
NOVELTIES, ETC.**

LATEST DESIGNS.

LOWEST PRICES



**CYCLING PROGRESS  
EXEMPLIFIED.**

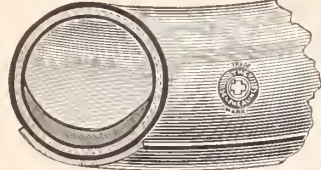

**THE WONDERFUL  
SELF-HEALING TIRES**

are single tube, finest rubber, finest wove Sea Island cotton fibre, re-enforced inside and outside on tread, and no better tire can possibly be made. They are fully guaranteed against all climatic changes, are the most resilient ever made, and when punctured instantly heal the wound of their own volition.

THEY WEIGH NO MORE THAN OTHERS,  
COST NO MORE,  
AND ARE WORTH TEN TIMES MORE.  
— SEND FOR TIRE BOOKLET —

**Wm. H. CAHN, GENERAL MANAGER,**  
48 and 50 Maiden Lane, New York.

BY EVERY TEST THEY ARE THE BEST.  
THE UNIVERSAL FAVORITES.



SUPERB  
**Olympic**  
BICYCLES

For sale by more than 2,000 Jewelers, and constructed to meet the demand for finest quality. For Adults and Juveniles.

SEND FOR EXQUISITE CATALOGUE.

Top Grade "Olympics" have SELF-HEALING TIRES.

Olympic Cycle Mfg. Co.,  
N. Y. Office: 35 LIBERTY STREET

General Jobbing Ag'ts, S. F. MYERS & CO.,  
WHOLESALE JEWELERS, Myer's Building, New York

**RECEIVER'S SALE!**

**TRADE OPPORTUNITY.**

Entire Stock of

**CHAS. JACQUES CLOCK CO.,**

22 Cortlandt St., New York,

**...Must Be Closed Out...**

Latest Paris Novelties,  
all New Importations  
of this Spring

Together with LARGE STOCK of

**ELLIOT CHIME CLOCKS,**

And a Fine Line of Other

**HALL CLOCKS.**

By order of

**ALBERT C. WALL, Esq.,**

Receiver.

**CUT GLASS FOR SILVERSMITHS.**



**STANDARD CUT GLASS CO.,**

545 to 549 West 22nd Street,  
NEW YORK.

**BAWO & DOTTER,**

26-32 BARCLAY ST.

NEW YORK.

P. O. Box 1872.

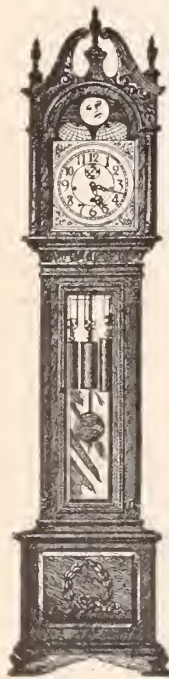

NO LARGER STOCK

OF

**HALL  
CLOCKS**

IS SHOWN IN  
THIS CITY.

Large Stock  
OF  
MOVEMENTS.

NEW DESIGNS  
IN CASES.

CAMPBELL-METOALF SILVER CO.,  
SILVERSMITHS,



ALL GOODS 925/1000 FINE.

Factory, Providence, R. I. Offices, New York and San Francisco.

**DUBOIS WATCH CASE CO.**

TRADE MARK REGISTERED.

FINE HAND MADE  
**SOLID GOLD CASES.**

A PRIDE TO THE MAKER,  
DEALER & WEARER.

**L. LELONG & BRO.,**

GOLD AND SILVER

Refiners, Assayers and Sweep Smelters,

◁ SOUTHWEST CORNER HALSEY AND MARSHALL STREETS, ▷

**NEWARK, N. J.**

SWEEPINGS A SPECIALTY.

**STERLING**

SHEET AND WIRE SUPPLIED ALL SIZES.

**J. SCHAWEL & CO.,**

Gold, Silver and Platinum Refiners.

29 John Street, N. Y.

**ROY PHOTO MINIATURES**

GIVE THE BEST RESULTS.

**ROY WATCH CASE CO., 23 MAIDEN LANE, NEW YORK.**

ALBERT LORSCH.

ALFRED KROWER

**ALBERT LORSCH & Co.,**

LORSCH BUILDING

37 & 39 Maiden Lane,

NEW YORK.



167 Weybosset St.,

PROVIDENCE, R. I.

IMPORTERS OF DIAMONDS, RUBIES, EMERALDS, ETC.,  
AND IMITATION STONES THEREOF.

•• Fine Miniatures on Ivory and Enameled Paintings. ••

**DIAMONDS** Importers and Cutters. **L. & M. KAHN & CO.,** 172 Broadway, Cor. Maiden Lane, N. Y., **DIAMONDS**

# THE JEWELERS' CIRCULAR

AND HOROLOGICAL REVIEW.

Copyright by THE JEWELERS' CIRCULAR PUB. CO.

189 Broadway, New York.

Entered at the Post Office in N. Y. as second-class matter

VOL. XXXII.

NEW YORK, WEDNESDAY, JULY 15, 1896.

NO. 24.

## INGENUITY IN MINIATURE REPRODUCTION.

THE engraving on this page shows a remarkable automaton, made by L. Houriet-Wuille, professor in the horological school of St. Imier, and now exhibited at the Swiss National Exposition, at Geneva, Switzerland. This work, which in the illustration is on a scale of one-seventh, represents a watchmaker at his work bench surrounded by all the tools and appliances, large and small, including his bench lamp, which he is called upon from time to time to use. The absolute accuracy with which these different articles have been executed is astounding. Mr. Houriet has at all times loved to reproduce in miniature objects of all kinds. This tiny workman and his tools have been produced with the greatest care and the work has been pastime for the creator for several years.

He commenced by making a Swiss lathe, not thinking at the time that one day it would be accompanied by all the rest of a watch-

maker's tools. The lathe was finished in 1873. Since then Mr. Houriet has been making smaller tools on the same scale, and when the

a work bench built on the same scale; he therefore made the work bench, but when it was finished he felt that something was lack-

ing, namely, the workman—the watchmaker—he who works at home, happy and contented with his lot, because he has in hand a well paying piece of work. The whole group was to serve as a reminder of the true watchmaker of yore, the workman who produced an horological mechanism. Mr. Houriet, the designer and constructor of the work, is a nephew of A. Houriet, with Edmond E. Robert, 3 Maiden Lane, New York.

It will be readily seen that it was easy work to make and to seat the figure upon the round stool, and then to operate the whole. But what of the troubles! There was also pleasure during the time devoted to the construction. Mr. Houriet went forward, little caring



AUTOMATON WATCHMAKER AT HIS WORK BENCH.

collection, which contains at least 70 pieces, was finished, the maker thought they would produce excellent effect when arranged upon

whether his ideas would turn out as he wanted them. After the watchmaker automaton was once in his place, Mr. Houriet desired to see

# KENT & STANLEY CO., LTD.,

## JEWELERS AND SILVERSMITHS,

### SEAMLESS GOLD FILLED CHAINS, JEWELRY, SILVER NOVELTIES.

NEW YORK OFFICE,  
21 and 23 Maiden Lane.



BOSTON OFFICE,  
403 Washington Street,

FACTORY, PROVIDENCE, R. I.

## NEW DESIGNS IN ALL LINES.

ALL OUR SILVER GOODS ARE GUARANTEED 925-1000 FINE.

### THE SPENCER OPTICAL INSTITUTE

OUR STUDENTS ARE THE SUCCESSFUL OPTICIANS.

OUR COURSE.

PRACTICAL,  
COMPREHENSIVE,  
NON-CLASSICAL.



YOUR GAIN.

KNOWLEDGE,  
PRACTICE,  
WEALTH.

SPENCER OPTICAL MANUFACTURING CO., 15 Maiden Lane, N. Y.

### BAND RING MOUNTING



DESIGN  
PATENTED  
Sept. 24,  
1895.



**CHARLES KNAPP,**

MANUFACTURING JEWELER,  
41 & 43 Maiden Lane, New York.

SPECIALTY: SUPERIOR LADIES' and CHILDREN'S RINGS



HOLYOKE, MASS., U S A.

## CHOICE PAPERS

## PARTICULAR ATTENTION

IS CALLED TO THE NEAT AND RICH  
STYLE OF OUR BOXING. OUR GOODS  
LOOK HANDSOMELY ON THE SHELF  
AND THE QUALITY ATTRACTS THE  
PURCHASER.

TRY THEM.

**PARSONS & GREENE Co.,**  
MANUFACTURING STATIONERS,  
HOLYOKE, MASS.

# HENRY FERA,

IMPORTER AND CUTTER OF

# DIAMONDS

PRESCOTT BUILDING,

65 Nassau St. cor. John NEW YORK.

FACTORY

60 Fulton St., NEW YORK.

Cutting for the Trade a Specialty,

## DR. KNOWLES' PRIVATE COURSE IN OPTICS.

Lectures with Diploma \$25.00

Those who desire to study with the Doctor will send in their application.

Students received at any time.

CORRESPONDENCE COURSE PERFECTED.

The Key to the Study of Refraction.

50c. per copy,

For Sale by

R. H. KNOWLES, M. D.,

189 Broadway, NEW YORK.

Care of JEWELERS' CIRCULAR.

## CROUCH & FITZGERALD.

Jewelry Trunks and Cases,

161

Broadway,

Bet. Cortlandt and Liberty Sts.,

888 B'way,

701 6th Ave.,

NEW YORK.



## THE SWAN FOUNTAIN PEN

Reputation World Wide.

Made upon Distinct Principles.

Is a Compressed Air Pump.

Simply Wet the Insides to Provoke an Energy.

W. W. Stewart, Inventor and Patentee.

A variety of Styles and Prices

3 Sizes Safety Swans.

3 Sizes Self-filling Swans.

3 Sizes Adjustable Feed Swans.

## MABIE, TODD & BARD,

NEW YORK AND LONDON.

## Why We Are Leading Locket Sellers.

Our line is most complete—Styles the very newest—We make lockets of all kinds—Gold Lockets, Gold Filled Lockets, Gold Front Lockets, Platinum and Gold Lockets,

Sterling Silver Lockets. We know all about Lockets—have nothing to think of or talk of but Lockets and similar goods. A large line of fobs, flat and drop seals.



Ask your jobber to show you our new Fall lines.

WIGHTMAN & HOUGH CO., Providence and N. Y.

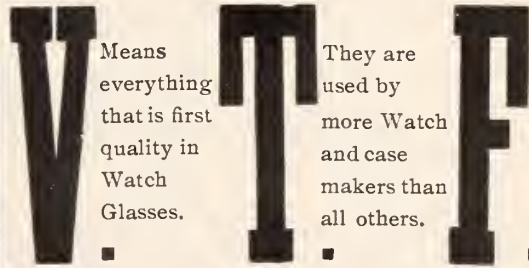

Means everything that is first quality in Watch Glasses.

They are used by more Watch and case makers than all others.

Their success has induced others to copy the label but not the quality.

## NEW ORNAMENTS

.. IN ..

## STERLING SILVER.



Many Designs in

Galleries, Belt Buckles, Belt Slides AND Belt Fastenings,

ALWAYS SOMETHING NEW.

## THOMAS W. LIND,

Manufacturer of

JEWELERS' FINDINGS.

67 Friendship Street,

PROVIDENCE, R. I.

**DIAMONDS.**  
**Wm. S. Hedges & Co.,**  
 IMPORTERS OF  
**Diamonds and Precious Stones.**  
**DIAMOND JEWELRY.**  
**170 Broadway, New York.**  
 22 Holborn Viaduct, London.

**Alfred H. Smith & Co.,**

IMPORTERS

**DIAMONDS**

AND

PRECIOUS STONES,

**182 BROADWAY, COR. JOHN STREET,**

**NEW YORK.**

Venetian Building. **34 & 36 Washington St**

**CHICAGO, ILL.**

**BATES & BACON**  
 "FAVORITE"  
 14K

**ALWAYS**

Ask to see  
 our

**BATES & BACON**  
 "ROYAL"  
 14K

**GOLD FILLED**  
**WATCH CASES.**

**None Better**

and

**Few Equal.**

**BATES & BACON**  
 "PURITAN"  
 14K

**HERMAN KOHLBUSCH, SR.**

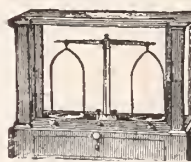

Established 1859  
 Manufacturer of  
 FINE BALANCES  
 AND WEIGHTS for  
 every purpose  
 where accuracy is  
 required. 59 Nas-  
 sau Street, cor.  
 Malden La. N. Y.



Repairs (any make)  
 promptly made

**SCHULZ & RUDOLPH,**  
 IMPORTERS AND CUTTERS OF  
**DIAMONDS AND OTHER PRECIOUS STONES,**

(Successors to JOHN E. HYDE'S SONS.)

**Sole Agents for The Celebrated Jules Jurgensen Watches.**

**28 JOHN ST. and 65 NASSAU ST., NEW YORK.**

# The Bowden Rings

ARE COMPLETE IN VARIETY, CORRECT  
 IN QUALITY AND PERFECT IN FINISH.  
 WE MAKE EVERY VARIETY OF FINGER  
 RINGS

**J. B. BOWDEN & Co.,**

**3 MAIDEN LANE,**

**NEW YORK.**

him work. Having decided that this should be the crowning piece of his dream, he made the hand, although he had never attempted such work before; he was required to frequently employ the file. The one hand completed, it appeared to be sufficiently natural, and the artist made the other. He next constructed the different parts of the body. But when trying to make the head, he found the work too difficult; the one made he considered to be unfit for exhibition at the National Exposition, or even to belong to the corporation of watchmakers. He therefore bethought himself of the artists at Brienz, and furnished the school of sculpture of that city the dimensions and necessary explanations; a short time afterwards he received a very handsome head, which, however, is not that now upon the shoulders of the watchmaker, because the gaze, in place of being fixed upon the work in hand, was directed to the other side of the bench. It was therefore necessary to make a second head, and this time the job was more successful. A clock movement, hidden in the body of the bench, serves as motor for actuating the leg, the fly-wheel and the lathe for 10 minutes.

This beautiful piece was therefore, except the head, constructed entirely by Mr. Houriet, and is justly entitled to figure high among the works by amateurs, where it will most certainly be admired, even by laymen.

## **New System of Standard Time of the Southern New England Telephone Co.**

NEW HAVEN, Conn., April 8.—The management of the Southern New England Telephone Co. announce that in a few weeks they will make a number of important extensions in their service. President M. F. Tyler and his corps of assistants are at work perfecting plans for a standard time service. There is now being manufactured for the company a large number of clocks which may be attached to the telephone wire. The timepiece is the invention of E. B. Baker, the company's general superintendent, and unlike the clocks used by other standard time concerns it is not actuated by an electric current, but has a regular movement, and is provided with an automatic electric self-winding mechanism, the power for which is supplied by a local battery.

The plan of the company is to sell these clocks to the subscriber and connect them to the telephone wire. Then twice every 24 hours synchronize them with a standard timepiece controlled by the Winchester observatory. The clocks are to be sold to the subscriber outright and no fee is to be charged for the work of synchronizing it twice daily. The company will, however, take charge of its maintenance and only charge what it costs them to keep the batteries in order, which will be a very nominal price. It is believed that the clocks will not need attention more than four times annually.

A jewelry store in East Troy, Pa., was entered last week by tramps, and valuables to the amount of \$500 taken.



**Summer Fashions in Jewelry and Silver.**

**A LADY'S RAMBLES AMONG THE JEWELERS\***

The bicycle lends itself to jewelers as a model, in witness whereof is the wheel chate-line, simulating in precious metals the bicycle wheel.

\*

Numbered with imported novelties is a silver toast rack which can be adjusted to the ordinary coffee cup. It accomodates two slices of toast.

\*

Miniatures set in a gold frame work afford popular buckles.

\*

Richly decorated cabinets with Vernis-Martin panels and glass shelves, divide favor with *bijouterie* tables with glass tops.

\*

The Summer girl wears the Trilby heart, with this difference: it contains a tiny mirror instead of photograph.

\*

There are watch chains that take their pattern from the bicycle chain.

\*

Very beautiful are the belt buckles of gold set with turquoises.

\*

Colored stems are becoming general in liquor sets.

\*

A large class of customers appreciate handsome cut glass inkstands with silver tops, which really hold a sufficient quantity of ink, and do not want refilling at the most inconvenient moment.

\*

Imported belts of enamel work on metal, are very beautiful.

\*

A novelty in diamond hair ornaments has a semicircle of stones, on which rests a gracefully modeled bird, set on a flexible mount.

\*

The newest bicycle belt is made with a little pocket at the side. The cover of the pocket is cut so that the face of a watch may be seen and thus combine a watch case and purse.

\*

Very unique is the necklace composed of a rope of pearls and rope of diamonds.

ELSIE BEE.

"The Jobbers' Handbook" for 1896, published by Walter B. Frost & Co., Providence, R. I., is issued. This book is 3 x 5 inches in dimensions, and is therefore of convenient shape for reference. It contains a list of manufacturing jewelers and kindred tradesmen, and as much care has been exercised in its production, this list is practically complete and reliable.

Fire broke out in the jewelry store of Ludwig Glasser, 106 State St., Olean, N. Y., at 11 o'clock last Monday night, completely destroying the entire building. Loss is placed at \$2,500. Origin of the fire unknown.

ESTABLISHED 1840.

**RANDEL, BAREMORE & BILLINGS**

IMPORTERS OF

**DIAMONDS,**

AND OTHER PRECIOUS STONES.

**FINE PEARLS A SPECIALTY.**

MANUFACTURERS OF

**DIAMOND JEWELRY**

A Large Stock of Fine Mounted Goods Constantly on Hand.  
Goods Sent on Approval and Insured in Transit.

Diamonds Cut, Recut and Repaired.

58 Nassau Street,  
29 Maiden Lane.  
NEW YORK.

1 Tulp Straat,  
AMSTERDAM.

1 St. Andrew's St.,  
Holborn Circus.  
LONDON E. C.

ESTABLISHED 1841.



**CARTER, HASTINGS & HOWE,**

MANUFACTURERS OF

**GOLD JEWELRY,**

**15 MAIDEN LANE, NEW YORK.**

A. CARTER

C. E. HASTINGS,  
W. T. CARTER,

C. R. HOWE,  
W. T. GOUGH,

FACTORY, NEWARK, N. J.

**WOOD & HUGHES,**  
**STERLING SILVERWARE MANUFACTURERS**  
New York Agents for the Derby Silver Co.,  
**FINE QUADRUPLE PLATED WARE**  
No. 16 JOHN STREET, NEW YORK  
206 Kearney St., San Francisco, Cal  
HASKELL & MUEGGE, Agents.

**FERD. FUCHS & BROS.**  
**SILVERSMITHS.**  
MAKERS OF STERLING SILVERWARE,  
808-810 Greenwich St., - New York.

## Among the African Diamond Mines.

KIMBERLEY, June 10.—Work goes steadily on at the De Beers mine, and there seems nothing to indicate that the supply of diamonds from this source will slacken for the next quarter of a century. An incident this week was the finding of a monster diamond weighing 513 karats. It is octahedron in shape, and is the largest stone ever found in any of the four mines owned by the De Beers Company. Several bigger ones have been found at the Jagersfontein Mine, in the Orange Free State, notably the famous "Jagersfontein Excelsior," said to be the very largest diamond in the world. This gem, by the way, is proving somewhat of a white elephant to the syndicate of owners who have had it lodged in the Bank of England, London, for several years, awaiting a purchaser. The value they put upon it is £1,000,000, and as diamond fanciers with £1,000,000 to spend are rather scarce just now, a deal is not easy. Some time ago negotiations were in progress with the object of securing the unique gem for the Crown of the Emperor of Germany, but they have fallen through. The diamond found in the De Beers Mine this week, however, is not likely to have such a romantic history as the Jagersfontein stone. It is unfortunately spotted, and, therefore, of relatively small value. The company proposed to christen it the "Barnato Diamond," but Mr. Barnato declined to honor a spotted stone

with his name, and some other cognomen will no doubt be adopted. The stone will be shipped to Europe next week.

I have just seen a parcel of stones from the Robinson Diamond Mine. They amount to 1,600 karats, and represent one month's output. They vary in size and quality, but on an average they may be classed as the highest priced goods in the market, fully equal to Jagersfontein, and in quotable value superior to De Beers pool prices. They go to London by this mail.

There is still much activity in the quest for new diamond mines, and large sums must have been sunk during the past 12 months in these enterprises. The reports from different new centers are encouraging, and in some cases rather exciting, but time alone can disclose whether the enthusiasm has been premature.

There is a growing agitation in favor of a tax upon diamonds. The principal objections to such a proposal appear to be that such an impost would be practically an export tax instead of an import one, such as we are already accustomed to; that it would be a tax levied upon one limited portion of the Colony, and on one particular industry; and that it would tell very heavily on the poorer diamond mines. In the case of a rich mine it may be assumed that one half the diamonds produced go to pay working expenses and the value of the other half represents the profits made. In the poorer mines the proportion of the diamonds produced which are required to pay working expenses may be represented

by three-fourths or four-fifths, while only one fourth or one-fifth represents the profit made. In the case of the debris washer and the river digger as much in some cases as nine-tenths of the diamonds produced are absorbed by working expenses, and only one-tenth is left as profit. A diamond tax would, of course, have to be levied on the whole amount of diamonds produced, without any reference to the profit made after paying working expenses, and would thus obviously press most severely on those branches of the industry which are making the least profit.

ST. GEORGE.

## Commissioner's Report on Last Year's Optical Patents.

WASHINGTON, D. C., July 8.—In the report of the Commissioner of Patents to Congress of the last fiscal year, concerning the business of the Patent Office, Mr. Seymour says:

"Invention appears to go in waves: while in none of the 214 classes in the Patent Office is there very complete stagnation, and in many there is a steady and regular average of work, in some others a noticeable increase in the number of applications will be for a length of time displayed.

"The relations which exist between industrial demand and inventive activity are very close. Each may be dependent upon the other. In any line in which there is little or no call there will be but little inventive effort; on the other hand, should any change or advance in industrial conditions cause a sudden increased demand for some article, means for producing that article or its equivalent will be created very rapidly in the brains of ambitious inventors."

There has not been a very marked activity along the lines of optical inventions. But a number of patents issued have been of unusual importance. An important scientific invention in this class is specially referred to by Mr. Seymour; it is the solarometer by Beehler, patent No. 533,340, January 25, 1895. This invention relates to instruments for taking observations of heavenly bodies and solving mechanically the parts of the astronomical triangle used in navigation and like work, the principal feature and object of which is to determine the position or the compass error of a ship at sea, independently of the visibility of the sea horizon. If the horizon is clouded and the sun or known star is visible, a ship's position can still be determined by the solarometer.

An important invention has been made by Fiske for determining the position and distance of distant objects, and is described in patent No. 418,510, December 31, 1889. The purpose of the Fiske invention is to provide a method by which the individual in charge of a gun may direct it upon a given target when the distance of said target is not known to him, and even when he is unable to see the target from the point where he is stationed, by reason of fog, smoke, breast works, or other causes. He accomplishes this object by stationing observers at points distant from the gun itself, which points are at the extremities of a known base line and command

# ARNSTEIN BROS. & Co.,

Importers and Cutters of

# DIAMONDS

65 NASSAU STREET,

CUTTING WORKS,  
45 JOHN STREET.

NEW YORK.

a view of the area within the range of the gun. The observers discover the position and range of the object by triangulation and set certain pointers. By means of electrical connections between these pointers and pointers at the gun station, based on the system of the Wheatstone bridge, the latter pointers, or the guns themselves serving as pointers, may be placed in position to indicate the line of fire.

That worthy benevolent and fraternal organization, the Jewelers' League of New York, has a record so far this year that must give great satisfaction to its members. The death losses since the beginning of the year have been only 12, and until this week there has been no death since Apr. 26th. This death loss just reported is the only claim unpaid, and it will be paid with the promptness for which the League is noted. When the number of members, 2,500, is taken into consideration, it will be seen that great care must have been taken in the selection of risks. The League is purely benevolent and fraternal in character, all its officers, with the exception of the secretary, serving without compensation. Young men connected with the trade should write to L. Stevens, Jr., 170 Broadway, New York, and ask for information in regard to the League. Every jeweler should join this organization for the benefit of his family.

Application has been made at New Orleans, La., for a receiver of the Orleans Jewelry Store, of that city.



THIS TRADE MARK MEANS THAT EVERY ARTICLE UPON WHICH IT IS STAMPED, IS **925-1000 PURE SILVER.**

IT ALSO MEANS THAT GOODS SO STAMPED ARE NOT SOLD TO DRY GOODS OR DEPARTMENT STORES, BUT ARE CONFINED TO THE LEGITIMATE JEWELRY TRADE.

NEW YORK,  
CHICAGO,  
SAN FRANCISCO.  
WORKS, PROVIDENCE.

**Gorham Mfg. Co.,**  
SILVERSMITHS.

**DORFLINGER'S**

**AMERICAN**

**CUT GLASS.**

915 BROADWAY  
36 MURRAY ST.  
NEW YORK.



# CARBORUNDUM

THE GREATEST ABRASIVE YET DISCOVERED.

Four times the Labor and Expense-saving qualities of Emery, Corundum or other abrasives. Adapted for Lapidary Work, Grinding, Polishing and every operation where a perfect abrasive is necessary

## Price List of Carborundum Wheels.

ACHESON'S PATENT, February 28th, 1893; February 26th, 1895.

DIAM. IN.	THICKNESS IN INCHES.																MAX. REV.
	1/8	3/8	1/2	5/8	3/4	1	1 1/4	1 1/2	1 3/4	2	2 1/4	2 1/2	2 3/4	3	3 1/2	4	
1	\$.15	\$.15	\$.20	\$.20	\$.20	\$.25	\$.30	\$.30	\$.35	\$.40	\$.40	\$.45	\$.50	\$.50	\$.60	\$.70	18000
1 1/2	.20	.25	.25	.25	.30	.30	.35	.40	.40	.45	.50	.55	.55	.60	.70	.75	14000
2	.20	.30	.30	.30	.35	.40	.45	.50	.55	.60	.60	.65	.70	.75	.85	.90	11000
2 1/2	.25	.35	.40	.45	.50	.55	.65	.70	.80	.90	1.00	1.10	1.20	1.25	1.40	1.50	8800
3	.30	.45	.55	.60	.65	.75	.85	1.00	1.15	1.25	1.40	1.50	1.60	1.75	2.00	2.20	7400
3 1/2	.40	.50	.65	.70	.80	1.00	1.15	1.30	1.45	1.65	1.80	1.95	2.10	2.20	2.55	2.90	6300
4	.50	.60	.75	.85	1.00	1.20	1.40	1.60	1.80	2.00	2.20	2.40	2.60	2.80	3.20	3.60	5500
5	.70	.85	.95	1.15	1.25	1.60	1.95	2.30	2.60	3.00	3.30	3.65	3.95	4.25	4.90	5.55	4400
6	.95	1.10	1.30	1.55	1.75	2.20	2.70	3.15	3.60	4.10	4.55	5.00	5.45	5.90	6.80	7.70	3700
7	1.25	1.45	1.65	1.95	2.30	2.95	3.50	4.15	4.80	5.40	6.00	6.60	7.20	7.80	9.00	10.25	3160
8	1.50	1.70	2.00	2.40	2.80	3.60	4.40	5.20	6.00	6.75	7.55	8.30	9.10	9.90	11.45	13.00	2770
9	1.80	2.10	2.40	2.90	3.35	4.30	5.30	6.25	7.25	8.20	9.15	10.10	11.10	12.05	14.00	15.90	2460
10	2.15	2.50	2.85	3.45	4.00	5.15	6.30	7.45	8.60	9.75	10.90	12.00	13.20	14.35	16.60	18.90	2210
12	2.65	3.10	3.70	4.50	5.25	6.80	8.40	9.95	11.50	13.05	14.60	16.20	17.75	19.30	22.45	25.50	1850
14			5.05	6.05	7.00	9.00	11.00	13.00	15.00	16.95	18.95	20.95	22.95	24.90	28.90	32.80	1580
16					9.10	11.70	14.30	16.85	19.95	22.90	24.55	27.15	29.70	32.30	37.40	42.50	1380
18					11.25	14.45	17.70	21.09	24.25	27.50	30.75	34.00	37.25	40.50	47.00	53.50	1250
20					17.50	21.55	25.55	29.60	33.70	37.80	41.90	45.95	50.00	58.00	66.00	1100	

The wheels are made with a vitrified bond and pressed under hydraulic pressure. Those over three inches in diameter are turned up after firing. The same numbers are used to designate the degrees of fineness, as are used with Emery, and the wheels are made in seven degrees of hardness, marked SSS, SS, S, M, H, HH, HHH, from extremely soft to extremely hard. In ordering, state diameter, thickness, hole, number and hardness.

Hones, Slabs, Files.

CUT THIS OUT.

# THE CARBORUNDUM CO.

WORKS: MONONGAHELA, PA., AND NIAGARA FALLS, N. Y.



Copyright, 1896, by The Jewelers' Circular Pub. Co., 189 Broadway, New York.

A Jeweler's Necessity

For eight months THE JEWELERS' CIRCULAR has had under way a work that will comprise the trade-marks of every branch of the Jewelry, Watch, Clock, Silverware, Silver Plated Ware, Optical Goods, Precious Stone, Art Pottery, Bric-à-brac, Cut Glass and cognate lines of the Jewelry Industry.

The work is now nearing completion. We consider it will be the most valuable book that has ever been issued to the Jewelry trade.

It is a work which the retailer and wholesaler will immediately appreciate.

It will be a book of constant reference, and will be consulted more perhaps than any other book issued to the trade.

It will be a book of daily use.

It will be sold at a figure that will guarantee its rapid distribution.

In addition to illustrations of the various trade-marks and the names and the addresses of the firms to whom they belong, and the class of goods to which they appertain, the work will contain other interesting and valuable information bearing upon the subject of trade-marks.

Members of the Trade, Manufacturers, Wholesalers and Retailers should at once place their orders for

**"TRADE-MARKS OF THE JEWELRY AND KINDRED TRADES."**

\$1 per copy. Bound in Cloth. Payable now or upon delivery of Book. Detach order below and forward to the Jewelers' Circular Publishing Co., 189 Broadway, New York.

Those firms who have as yet not sent electrotype, print or drawing of their trade-mark or trade-marks are requested to do so at the earliest possible moment.

**ADVANCE ORDER BLANK.**

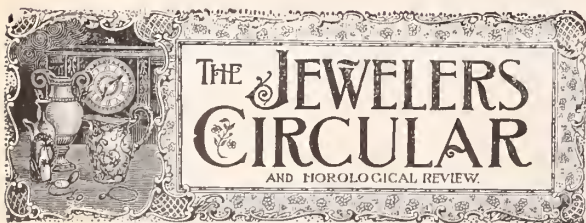

189 Broadway, New York

..... 1896

Please file this order for ..... copy of

**"Trade-Marks of the Jewelry and Kindred Trades"**

for which I agree to pay \$1.00 per copy, postage prepaid, upon delivery of book.

Name .....

Street.....

City.....

State.....

**Outing of the New England Jewelry Travelers' Association.**

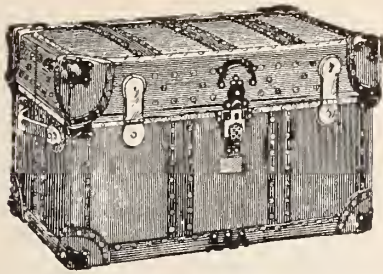

THE EMBLEM OF THE NEW ENGLAND JEWELRY TRAVELERS.

BOSTON, Mass., July 11.—The most popular "trunk" line out of Boston this afternoon was the route taken down the bay by the natty little steam yacht *Skylark*, bound for the landing at the Relay House, Bass Point, Nahant. The occasion was the annual mid-summer outing of the New England Jewelry Travelers' Association, but the participating members had all left their sample trunks behind them this afternoon, and only carried to the wharf a bit of pasteboard on whose face was the sign of the association trunk, admitting them to the inner circle of the elect.

When upward of two dozen voyagers had stowed themselves away comfortably aboard the launch she was pointed for the land of fish dinners and lost no time getting there. At the hotel a very enjoyable banquet found due appreciation from appetites whetted by the sail down the harbor. President Edward W. Merrill sat at the head of the table, and Commodore Chas. F. Morrill, who has been the host of the members on board the *Navarch* in previous years, was the honored guest of the occasion.

A brief time was devoted to business. Amendments to the by-laws were proposed and adopted, providing for the admission of employes of jewelry concerns, who are not road representatives, to associate membership in the organization.

Brief addresses were a feature of the after dinner programme, among the speakers being the president, Mr. Morrill, ex-president John L. Shepherd, of New York, secretary William C. Wales and Robert M. Hamilton. Commodore Morrill stated that in the new building which he is to have built for him in Boston he would like to provide quarters for a permanent club home for the traveling men's association. Messrs. Wales, Shepherd and Hamilton all favored the eventual enlargement of the organization to embrace travelers in kindred trade lines and perhaps the making of the jewelry association the nucleus for an association of all traveling men in this section, after the type of the New York commercial travelers' club. It was also voted that the next meeting of the association be a ladies' night banquet occasion. This event will take place in December next.

On the return trip a sail of about two hours was enjoyed in the wide stretch of harbor, and the time passed pleasantly, with songs and drummers' yarns to beguile the passing moments. The *Skylark*, which was chartered

by E. W. Martin and Robert M. Hamilton and placed at the disposal of the executive committee for the day, proved to be just the boat in which to go off "on a lark." Three rousing cheers and a vote of thanks were given for the Providence contingent, which was declared by vociferous acclamation to be "all right."

Among those participating were: Edward W. Merrill, salesman for D. C. Percival & Co.; Charles F. Morrill, of Morrill Bros. Co.; Edward W. Martin, Martin, Copeland & Co.; William C. Wales, Waterbury Watch Co.; John L. Shepherd, Keystone Watch Case Co.; Horace P. Howard, Towle Mfg. Co.; W. N. Arzen; T. Frank Bell; Robert M. Hamilton, Hamilton & Hamilton, Jr.; James H. Conner; Charles M. Ballard, Hayden W. Wheeler & Co.; Harry F. Hayes and A. A. Wood, Howard Sterling Co.; Fred. J. Wildes and Horace B. Pearson, Shreve, Crump & Low Co.; Henry R. Arnold, Edward S. Roberts, William E. Clement and Frank E. Buffum, D. C. Percival & Co.; George E. Morrill, Morrill Bros. Co.; George M. Kingsbury, Jr., Hamilton & Hamilton, Jr.; George L. Swett, Simpson, Hall, Miller & Co.; Frank F. Place; Thomas G. Frothingham, T. G. Frothingham & Co.; Walter B. Snow, Poole Silver Co.

Letters of regret were read at the banquet from Fred. H. Carpenter and Wade C. Wil-

liams, now in San Francisco, and from ex-president Daniel Stevens.

**Cincinnati Wholesalers Discuss Interesting Subjects.**

CINCINNATI, O., July 11.—The Cincinnati Wholesale Jewelers' Association held their regular monthly meeting Tuesday, president L. Gutman presiding. Several matters of minor importance were taken up, but the principal subject of interest was the credit system that the jewelers feel is of the greatest importance to them. Owing to the absence of several of the members from the city, the matter was laid over until the next meeting when a full attendance is expected and something done with the subject.

The matter also of the new National Jobbers' Association was discussed, and, as mentioned in a previous issue of THE CIRCULAR, the Cincinnati jobbers do not favor it as a jobbers' association, but think that if the manufacturers were in earnest about abating the cutting evil and other abuses, they could remedy the matter themselves; and that no amount of good can be accomplished by the jobbers alone. The meeting adjourned without taking any decisive steps in the matter.



**E. KIRSTEIN'S SONS CO.,**  
MANUFACTURERS OF  
**Optical Specialties,**  
**ROCHESTER, N. Y.**

NEW CATALOGUE NEARLY READY.  
 SEND US YOUR BUSINESS CARD.





**"PLAYING DOCTOR."**

Here is another of Rogers' beautiful groups, filled with humor and life. It represents three interesting children at play, cleverly grouped, so that a most artistic effect is given without destroying the naturalness of the scene.

Price, \$9.00. Send for Catalogue. Agents wanted.

**Rogers Statuette Co.,**  
 441 Pearl St., N. Y.

## Death of Adolph Luthy.

Adolph Luthy, of Lewis, Kaiser & Luthy, has passed away, and in his death New York has lost one of her oldest and most widely known manufacturing jewelers. Mr. Luthy died Tuesday, July 7, after an illness of a



THE LATE ADOLPH LUTHY.

week's duration, at his home, 154 West 136th St., New York, from a disease of the gall bladder. He had suffered from this trouble more or less for the past year.

Adolph Luthy was a native of Switzerland, where he was born in October, 1841. He was but seven years old when his parents came to the United States and settled in Cincinnati, O. In this city Mr. Luthy grew up, and when old enough to go to work learned the jeweler's trade under Mr. Saradino, foreman for Duhme & Co. With Duhme & Co. Mr. Luthy worked until 1861, when his young blood being fired by President Lincoln's call for troops, he left his work to enlist in the 9th Ohio volunteers, and served with them through the war. At the close of the Rebellion he returned to Cincinnati, but shortly afterward, in 1866, he went to New York and obtained a position in the factory of Randel, Baremore & Billings.

After remaining here about two years he worked for a short time with Downing & Kellar, and then became foreman and designer for the firm of Baldwin, Sexton & Peterson, with whom he remained until the firm's dissolution about 1882. It was during the years Mr. Luthy had charge of Baldwin, Sexton & Peterson's factory that his fame as a designer and maker of jewelry spread through the trade and the "Luthy" mountings became celebrated with the jewelers all over the country.

After the dissolution of Baldwin, Sexton & Peterson, Mr. Luthy first started in business for himself, forming a partnership with John Haug under the firm name of Luthy & Haug. The firm dissolved about 1885 and Mr. Luthy formed the firm of A. Luthy & Co. with E.

Aug. Neresheimer as a partner. Mr. Neresheimer's interest was purchased by F. W. Lewis, in December 1884, the firm name remaining the same, but on Jan. 1, 1889, when David Kaiser was admitted, the firm style was changed to Lewis, Kaiser & Luthy which has continued ever since. Mr. Luthy was always the factory man of his firm, and was the patentee of over a dozen devices in pins, earrings, etc., which are to-day among the most widely known and popular mountings handled by the trade.

Mr. Luthy's death will be deeply regretted by all who knew him. He was a genial, even-tempered, straight-forward man. Every one who knew him was his friend and none his enemy. The deceased was a member of the Jewelers' League and of the Arion Society. He leaves a widow and four children. The funeral services, which were held at his residence Wednesday evening, were attended by a large delegation from the jewelry trade.

The partnership of Lewis, Kaiser & Luthy, manufacturing jewelers, 35 Ann St., New York, which was dissolved by the death of Adolph Luthy, July 7, will be continued by F. W. Lewis and David Kaiser, the remaining partners, under the old firm name.

### Election of Officers of the Missouri Retail Jewelers' Association.

ST. LOUIS, Mo., July 10.—The Missouri Retail Jewelers' Association held their annual meeting on Wednesday evening, July 8. The election of officers resulted as follows: President, Gerhard Eckhardt; first vice-president, O. H. Kortkamp; second vice-president, Chas. G. Derleth; recording secretary, George R. Stumpf; financial secretary, Arnold Zerweck; treasurer, F. W. Bierbaum; directors, Herman Mauch, C. W. Hoen, C. Osterhorn, John Schmidt, J. Ryser, John Zeitler, William Henkler, F. H. Niehaus and W. F. Kemper. The following were selected to represent the local association as delegates and alternates at the National Convention at Atlantic City: George R. Stumpf, Arnold Zerweck, C. G. Derleth, O. H. Kortkamp, F. H. Niehaus and F. W. Bierbaum. The Missouri Association is in a flourishing condition. At the meeting the annual reports of the retiring officers, president, recording secretary and financial secretary, were accepted and placed on the minutes. A motion was carried to recommend the Northeastern Burglars' Insurance Co., Boston, Mass.

### Fred. Lomberg Proves an Easy Victim to a Buncoing Watchmaker.

ST. LOUIS, Mo., July 10.—A man named Fred. Lomberg, whose father, a watchmaker in Washington, Mo., recently died, received \$600 from the latter's estate. Several weeks since he came to St. Louis and asked the M. Eisenstadt Jewelry Co. to hold the check for this amount pending a decision on his part as to what he should do with it. While they were averse to receiving the money, still they did so on his earnest solicitation. A few days after his arrival in St. Louis he met a man

named Jas. B. Johnson, who was a good talker, a trim dresser and an experienced watchmaker. He had recently come to town and had applied to the M. Eisenstadt Jewelry Co. for work. He learned that Lomberg had some money, and suggested that it be invested in a jewelry business. Lomberg bit at this, and went to the Eisenstadt Co. and told them his cousin was going into partnership with him. On this representation the money was turned over to him. Then Johnson and Lomberg went out to find a location for the proposed business.

A vacant store at 1012 N. Vandeventer Ave. was selected, and then Lomberg turned over his \$600 check to Johnson to pay the rent for the store, buy a stock of goods, etc. The next morning Johnson failed to appear. After waiting some time Lomberg decided to go to his partner's residence, but on arriving there found that gentleman gone, and he has not laid eyes on him since. Johnson had cashed the check, and all efforts to locate him so far have proved futile. Lomberg immediately took steps to cause the arrest of Johnson, but failed to secure a warrant, the circuit attorney claiming that Lomberg and Johnson were partners at the time the latter decamped with the money.

Lomberg subsequently told the M. Eisenstadt Jewelry Co. that the reason he told them that he was going in business with his cousin was that he had been told by Johnson to make this statement. The latter was evidently under the impression that his scheme would be tripped up if it became known, and that the M. Eisenstadt Jewelry Co. would warn Lomberg if he told them what he was going to do with the money.

### Fire in Fitzgerald Building, Providence.

PROVIDENCE, R. I., July 7.—A fire that started in the extensive factory building of M. Fitzgerald, Eddy St., did considerable damage in three of the manufacturing jewelry establishments upon the fifth and sixth floors of that building. There are nearly 30 concerns in this building and had the fire not been discovered when it was, it would have been attended with a considerable destruction of property with heavy loss.

Just before 7 o'clock last night one of the employes of E. L. Logee & Co., as he was leaving the building, discovered smoke issuing from the sixth floor. He at once sent out an alarm and upon the arrival of the department it was found that the shops occupied by Phil. Riley & Co. and Catlow Bros. were all aflame. The interiors of the shops of these two concerns were nearly thoroughly destroyed and the shop of M. Fitzgerald on the floor beneath was badly damaged by water.

The damage done to the building, the stock and machinery of the three occupants who were affected by the fire amounts to about \$10,000, about half of which constitutes the damage to the building. There is a total insurance upon the building of \$50,000 divided among several companies. Phil. Riley & Co. have an insurance of \$2,000 and Catlow Bros. one of \$3,000. M. Fitzgerald's stock is insured for \$1,500.

**News Gleanings.**

W. H. Reed will go out of the jewelry business in Toronto, Kan.

H. H. Sawyer, Kansas City, Kan., has been sued on a note for \$897.

Frank Hester, Lawrence, Kan., has been sued for a small amount.

T. P. Whiting has removed from Jasper, N. Y., to Harrison Valley, Pa.

The stock of S. W. Bramley, Kingsston, N. Y., is being sold at public auction.

Martin Koch's jewelry business, Hazleton, Pa., has been sold at constable's sale.

H. M. Berry, Wichita, Kan., has paid the mortgage for \$1,200 which he recently gave.

C. E. Abbott, Herrington, Kan., has given a chattel mortgage on his jewelry store for \$1,534.

An attachment for \$138 has been placed on real estate belonging to J. B. Patterson, Riverside, Cal.

A cage of squirrels in the window of Kohn's jewelry store, Missoula, Mont., is proving a great drawing card.

O. E. Reese, Joplin, Mo., has given a trust deed for \$250, and one has been released against him for \$600.

J. Barney Rentz has opened a new jewelry store in Miami, I. T., having moved there from Baxter Springs, Kan.

Wm. Holloway, who operates both a jewelry store and hotel in Friday Harbor, Wash., has given a chattel mortgage for \$135.

The Tebbets Jewelry Co., Bangor, Me., have

bought the business of W. O. Colomy, jeweler, Main St., and took possession at once.

Emil A. Henschober, who is in the jewelry business in Port Townsend, Wash, has changed his name to Emil A. Schober.

W. J. Abbot, jeweler, Pocohontas, Va., who has been hunting his wife and her paramour, found them in Sistersville, W. Va., after a four days' search. She has promised to go home.

These jewelers of Chambersburg, Pa., have agreed to close their respective places of business each evening at 6 o'clock P. M., Saturday excepted, beginning Monday, July 6, and ending Sept. 15, 1896: Geo. W. Ludwig, W. E. Blocher, A. V. Reineman, I. S. Riker.

Articles of incorporation of the Shook-Sellner Co., Omaha, Neb., have been filed. The company are a reorganization of the Shook-Patterson Jewelry Co. The new company have a capital stock placed at \$30,000, and C. L. Shook, George Sellner and E. E. Johnson are the incorporators.

Zora Trumbo was arrested a few days ago in Morehead, Ky., on a charge of breaking into the jewelry store of Hamilton Bros. He was held over on a \$500 bond. About noon Trumbo was seen to enter the store from a rear window while the proprietors and clerk were at dinner. When they returned they found missing twelve gold filled watches valued at \$200.

F. E. Hewitt, a traveling salesman for a jewelry house, was robbed while on a train on the Chicago Great Western railway last Mon-

day night between Reinbeck and Waterloo, Ia. He had two sample cases with him and while asleep in the chair car with the cases by his side, one of them containing rings to the value of \$400 was taken. The robbers made their escape from the train without being detected.

**Proceedings of the Jewelers' Security Alliance.**

The regular monthly meeting of the executive committee of the Jewelers' Security Alliance was held at the Alliance office on the 10th inst. There were present J. B. Bowden, president; Bernard Karsch, treasurer; H. H. Butts, chairman, and Messrs. Kroeber and Abbott and Geo. H. Hodenpyl, secretary.

The following firms were admitted to membership: Ferguson & Craig, 33 Neil St., Champaign, Ill.; Glorieux & Woolsey, Irvington, N. J.; Maier & Berkele, 93 Whitehall St., Atlanta, Ga.; L. W. Rubinstein, 54 Maiden Lane, New York.

**HE GOT THE PLACE.**

Merchant—Have you had any experience in chinaware?

Applicant—Years of it, sir.

Merchant—What do you do when you break a valuable piece?

Applicant—Well er—I usually put it together again and place it where some customers will knock it over.

Merchant—You'll do.—*London Fun.*

**LEATHER GOODS FOR FALL.**

NEW LINE NOW READY.

Comprises Full Assortments. . . . .



LEVANT.

**POCKETBOOKS,  
CARD CASES,  
BILL BOOKS,  
CHATELAINE BAGS  
and BELTS** in all lengths  
and widths.

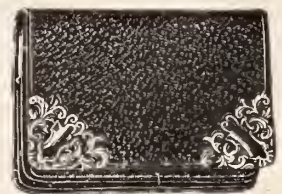

CREPON.

We manufacture all our own goods and use only Sterling Silver and Gold Mountings.

We have special facilities for filling

**MAIL ORDERS.**

Such orders from dealers who have no account with us should, to receive prompt attention, be accompanied by New York City references.

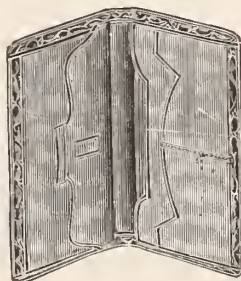

SEAL.

Also many other Novelties which cannot be enumerated in this limited space.

We have prepared an unusually fine and extensive line of these goods in anticipation of an increased demand for these popular articles in the fall. Exclusive and artistic patterns. Our prices are right.

*J. J. Cohn*

**65 NASSAU STREET,**

(New Prescott Building.)

**NEW YORK.**

PRESIDENTIAL CAMPAIGN BUTTONS, ETC.

PART I.

For many years past the occurrence of the Presidential election, while it has tended to depress general business, has helped out the jewelry industry to some extent in satisfying the demand for badges, emblems, buttons and various insignia bearing upon the Presidential candidates and the political questions at issue. Many manufacturers in the east have in years past looked forward with much hope to this

before the people are the most engrossing that have occupied attention since the war. Men are divided by principles. They have convictions which are deep and sound, and they would sacrifice time and money for the ideas that possess them. These men want badges to wear on their coats in order to let their fellows know just where they stand. The badge is more than an indication; it is an



SOME CAMPAIGN EMBLEMS PRODUCED BY WHITEHEAD & HOAG.

event, but this stimulus to business has gradually decreased as far as the legitimate jewelry trade is concerned, until to-day this part of the manufacturing branch of the jewelry industry is comparatively small. This year the manufacturers who have gone into the production of this class of goods, with few exceptions, are carrying out orders for individuals who have patented designs and who market the goods themselves; however, there are a few firms who have made a great run on badges and emblems, and who have produced hundreds of thousands of these goods.

Notwithstanding the comparatively small part the regular manufacturing jewelers play in the production of campaign goods, it is probable that this will be the greatest year ever known for campaign badges. The issues

argument and a challenge to further discussion.

No sooner were the Republican nominations made than Whitehead & Hoag, the well known badge and button manufacturers, of Newark, N. J., placed the McKinley and Hobart badges and buttons on the market, some of which are here illustrated, and they were quickly snapped up by ardent Republicans. The most conspicuous of these symbols is a medallion, two inches in diameter, containing excellent likenesses of the two candidates, suspended by a small silk American flag from an ornamental gold colored clasp. Tens of thousands of these badges are already worn.

The Gold-Bug badge made by this firm, showing one's adherence to the single monetary standard, is a solid piece of yellow metal

made to represent a gold beetle about an inch in length. The largest of the buttons is over an inch in diameter. One bears upon its face a likeness of McKinley, surrounded by the folds of the Stars and Stripes. The Stars and Stripes are well colored. Another of the same size bears portraits of McKinley and Hobart. There's another McKinley and Hobart button that is not more than half an inch in diameter. Even at that size the likenesses are very good.

The elephant button made by Whitehead & Hoag is an out-and-out Republican emblem. "Grand Old Party" are the words it bears. Then comes the "M-c Kin-ley, Sis-Boom-Ah! Hobart" cheer button. There are three buttons out for the silverites. One is colored to represent half silver and half gold, and bears stamped on it the figures "16 to 1," and another is a blue faced clock with the hands at 16 minutes to 1 o'clock. A number of distinct Democratic badges will be shown next week.

Between 300 and 400 employes are kept busy in the big factory of this firm at Newark, N. J., producing all sorts of buttons and badges for bicyclists, societies, etc., campaign buttons, of course, having the call now. Skilled artists, designers and metal workers are constantly engaged on new ideas.

THE GOLD BUG AND THE SILVER BEE.

Smith Bros., Providence, R. I., are driven on a campaign novelty, the "gold bug." This represents a bug about an inch and a half in length with its wings folded. By touching a small spring these wings expand and upon one is seen the photograph of McKinley and

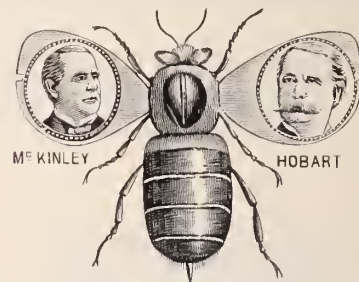

THE BELLEW GOLD BUG OR SILVER BEE.

on the other that of Hobart. They are also now making a silver bee for the Democrats similarly constructed. The firm are making these goods for the inventor, T. S. Bellew, Providence, R. I., who received a patent on the device on May 1, 1896. The sale of these campaign emblems, which are made in either gold or silver plate, is very large, 250 hands, it is said, being kept at work producing them.

MCKINLEY HATS, ETC.

Payton & Williams, 176 Broadway, New York, are disposing of large quantities of campaign goods in many designs. Of McKinley hat buttons, as shown, four varieties are made: hat of gold plate, with cockade of silver plate, hat of silver plate with cockade of gold plate, enameled in blue, hat of gold plate with cockade of silver plate, and enameled in blue, hat of silver plate and cockade of gold plate. The "Favorite Republican Button" is a four leaf clover, in red, white and blue hard enamel,



one leaf containing the words "Honest Ballot," the next, "Honest Money," the next, "Protection," and lowest "Reciprocity." The "Favorite Democratic Button" is a three leaf clover in red, white and blue hard enamel, the leaves disclosing the words, "Tariff for Revenue," "Sound" and "Money." The McKinley sound money button is finished



CAMPAIGN BUTTONS—WILLIAMS & PAYTON.

in pure gold plate. It contains a portrait of the Republican nominee, surrounded with the words "Protection. Sound Money." The "Free Silver Coinage" lapel button is in blue hard enamel of silver plate, with the center of gold plate. Other campaign goods produced by this house are a Prohibition button in white hard enamel, a Populist button in red, white and blue hard enamel, a "Republican League" lapel button in red, white and blue hard enamel, National Association of Democratic Clubs button in red, white and blue hard enamel, American flag buttons and pins, and Cuban flag buttons and pins.

The cut below shows the leading badge which Wm. H. Luther & Son, Providence, R.

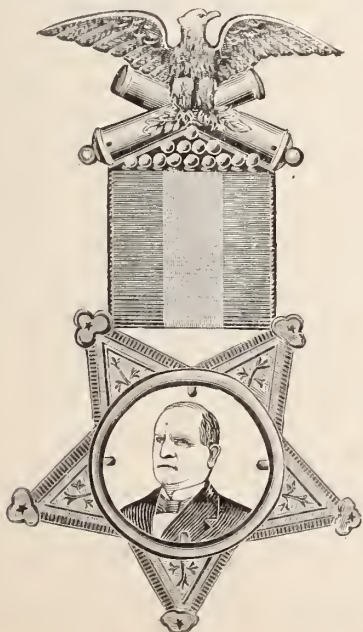

CAMPAIGN BADGE—WM. H. LUTHER & SON.

I., have made during the last three campaigns with increased sales each year. This firm probably make the largest assortment of this class of goods in the country. The line includes lapel buttons and badges.

THE LITTLE NIPPER.

R. F. Outcault's series of "Hogan's Alley" pictures in the colored supplement of the New York *Sunday World* have become famous in the field of comic journalism. The doings of the youngsters in Hogan's Alley are proving and laughable successors of those of Palmer Cox's Brownies, while the boys and girls are as definite and comical characterizations as Artist Cox's creations. Notwithstanding the burlesque exaggerations of the events depicted, an atmosphere of truth pervades them, the doings and sayings of the urchins being based upon existing idiosyncrasies of thought and action in a certain plain of society. An especially comical character is the bare footed urchin of Mongolian



THE LITTLE NIPPER—WILLIAMS & PAYTON.

aspect and in yellow pinafore who always forms the center of the group. He is of Mugwump tendencies and has now declared himself for McKinley. This figure, which has been dubbed "The Little Nipper," after music hall singer Chevalier's ballad, has become especially famous, and has been perpetuated in metallic form by Williams & Payton, Providence, R. I., as illustrated above, in which he announces that "Hogan's Alley is out fer McKinley." This device, which is enameled in yellow, makes an admirable campaign pin, and will undoubtedly have a boom.

(TO BE CONTINUED.)

Pigeons as a Means for Smuggling Diamonds.

A New York newspaper last week published an alleged expose of a gigantic scheme to smuggle diamonds into this country by means of carrier pigeons. Among other things it said:

"According to information received at the custom house the smugglers are training a number of homing pigeons to fly from the lower bay to a dovecot in this city. When these pigeons are sufficiently trained the gang proposes to use them as winged smugglers and to have them carry diamonds into port. A member of the gang will take the birds to Europe. There he will meet other members



It Pours Good Things

IN THE JEWELERS' CIRCULAR!

Optical Department, Workshop Notes, Retail Advertising, Seasonable Fashions, Buyers' Bureau Connoisseur.

\$2 per year—4c per week.

who have purchased a quantity of precious stones. He will take the stones and pigeons and sail for New York. As he nears this port

**WATCH** **GOLD FILLED.** **CASES**  
*Fabry's* 4K **MONARCH**

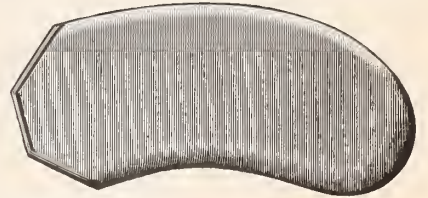

**WHITE'S EYE SHADE.** **W. B. WHITE & SON,**  
 90 South St, Boston,  
 MANUFACTURERS OF  
**Spectacle and Eye-Glass Cases.**

White's Adjustable Eye Shades and Specialties in Fancy Leather Goods, Etc.  
 LARGE STOCK OF CASES ALWAYS ON HAND.

**COMFORT AND SECURITY ARE COMBINED IN MERRITT'S PATENT EYE GLASS HOLDERS.**  
 Made by Merritt, Gargill & Co. Springfield, Mass.  
 GOODS ON APPROVAL. CORRESPONDENCE SOLICITED.

**Fox & Stendicke,**

Manufacturing Opticians,  
 61 Fulton St., New York.  
 Javal, Schiötz Ophthalmometers, Phorometers, Skiascopic Apparatus, etc., etc.  
 Send for Price List.

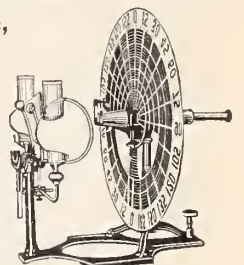

**SECURITY PIN GUARD**  
 PAT'D DEC. 25, 1894  
 MAN'D BY SECURITY MFG CO. **25¢**  
**7 ASTOR HOUSE (BROADWAY) N.Y.**

85c. doz. Net Cash. Discount to Jobbers

ALL KINDS OF **SKELETON** FOR **SILVERSMITH** MANUFACTURED BY **CHULDER BRO**  
 FACTORY AT SOLINGEN, GERMANY. FOUNDED 1850  
 545 & 547 PEARL ST., NEAR BROADWAY, NEW YORK.

he will attach the stones in small parcels to the pigeons and, awaiting a favorable opportunity, will release the birds. Other members of the gang in this city will be on the watch and receive them. There will be little danger, less difficulty and big profits. The outlay for the 'plant' will be small. Pigeons cost little and are easily trained. As a matter of fact, however, it is said that the gang has taken the owner of a large number of homing pigeons into their counsels and he is to guarantee the smugglers against loss. On the other hand, he is to share liberally in the profits if his birds prove to be expert smugglers. Detectives are working on the case and trying to locate the gang and the dove-cot. Close watch will be kept on incoming steamers."

### Pittsburgh.

Harvey F. Wattles is at Mt. Clements, Mich.

J. Rudert, McKeesport, Pa., is closing out at auction.

B. F. Rosen, McKeesport, has removed to Bellwood, Pa.

Max Arnheim, Liberty St., is on the sick list with typhoid fever.

Mr. Blank, Penn Ave., is closing out his stock and fixtures to quit the business.

E. J. Bubb, manufacturing jeweler, has sold out his interest to J. Haley. Mr. Bubb will devote himself in the future to his Wildwood oil interests.

The sheriff has sold out the store of F. Henry, McKeesport, Pa. Mr. Henry left the city several weeks ago. Nothing has been learned of his whereabouts.

Heeren Bros. & Co. are putting the finishing touches on their new building. When finished it is said the store will be the finest jewelry house west of New York.

Harry Reinhart, of Grafner Bros., will travel for Leo. G. Vilsack. Chas. O'Brien, formerly traveling salesman for Mr. Vilsack, will manage the store for W. G. Johnston & Co.

Philip Gillespie, of W. G. Johnston & Co., will open a new store in the Park building as soon as it is completed. Mr. Gillespie will be assisted by his brother, who will also be one of the firm.

John Zug, Carnegie, Pa.; J. C. Rhodes, Honesdale, Pa.; Leo Furtwangler, Greensburg, Pa.; Bert Neville, Dawson, Pa.; N. C. Cochran, Fairmount, W. Va., were the visiting jewelers in town the past week.

The jewelers in this city are much gratified at the condition of business for this time of the year. The general report is that they are selling more diamonds and watches besides higher priced goods generally.

J. P. Steinman, Federal St., Allegheny, has purchased additional frontage to his store, and added 40 feet in the rear. Mr. Steinman intends remodeling the place, adding new cases and fixtures.

During the past week the following Pittsburgh jewelers have left the city for their vacations: J. Kintz, Heeren Bros. & Co., has gone to the mountains in the eastern part of the State; O. E. Heineman to Atlantic City;

Harry Heeren to the Cheat River for a season of fishing; Will Terheyden will spend his vacation on Lake Erie; R. Siedle will be in the east looking up new goods; A. M. Andrews, Atlantic City.

### Connecticut.

The flatware department at C. Rogers & Bros.' factory started again July 8.

The Middletown Plate Co. have closed for repairs. The men will probably have two weeks' vacation.

Jeweler C. C. Carroll, Wallingford, will open a branch store in the building in Wallingford, formerly occupied by L. A. Hill.

The Watrons Mfg. Co., and Simpson, Hall, Miller & Co., of Wallingford, closed their works, July 3, for their Annual summer vacation.

Appraisers were in Danbury, July 8, for the purpose of inventorying the property of Frank Benedict, of Breckbill & Benedict, Bridgeport.

The Meriden Britannia Co., Wilcox Silver Plate Co., C. Rogers & Bros., M. B. Schenck & Co., Edward Miller & Co., and other corporations have petitioned the Meriden city government for a reduction of the water rent rates, which are held to be excessive.

Notices were posted in the shops of the Seth Thomas Clock Co., July 6, that the works will be closed on the night of July 16 until Aug. 3. This is a somewhat shorter period than usual, and the notice being given so early is appreciated by the employes.

### Boston.

John B. McCloskey, with Nelson H. Brown's clock house, spent convention week in Chicago.

D. C. Percival, jr., is in camp at Hingham this week with the crack 1st corps of cadets, of which he is a member.

George Howard has been on a yachting trip along the north shore to Boothbay Harbor the past fortnight with a party of Boston friends.

Buyers in town the past week included: George O. Foye, Athol, who was the guest, Independence Day, of Horace P. Howard, of the Towle Mfg. Co., at Newburyport; Mr. England, of England & Leavitt, Worcester.

A. W. Armington, buyer of diamonds and gems for Shreve, Crump & Low Co., is in London this month and Frank Fuller, buyer of foreign bronzes, clocks, and art curios for the company, has gone to Paris on a business trip.

O. A. Drinkwater's many friends welcome him back to business once more with much pleasure. He has been on the sick list for several months, but is now able to return to his desk at Morrill Bros. Co.'s establishment.

### Philadelphia.

Joseph T. Bailey, Clement Weaver and Samuel Jacquette, of Bailey, Banks & Biddle Co., have returned from abroad.

M. Zineman & Bro. have hit upon a novel scheme. They announce that colored eye-

glasses to protect the eyes from sun and dust will be given, free of charge, to bicycle riders. The glasses are enclosed in leather cases.

Clark Brothers, Chestnut St., recently announced a reduction and "change in business" sale. The impression soon prevailed that a change in the partnership was contemplated. This is denied, however, and a representative of the firm stated at the store that the "change in business" was simply a mistake of the sign painter. W. L. and H. W. Clark, he said, will continue the business as formerly.

President Sackett, of the Jewelers' Club, who is organizing a base ball team with a view to playing a championship game with New York jewelers, is experiencing considerable difficulty in having his amateur ball players line up for practice. Hot weather interfered with his plans, the players complaining generally of the torrid temperature. They now advocate the scheduling of a game for September or October instead of early August as was first contemplated.

A. C. Becken, wholesale jeweler, Columbus Memorial building, Chicago, says the Paillard Non-Magnetic Watch Co. are here to stay, both at the old stand, 177 Broadway, New York, and the salesroom of A. C. Becken in Chicago. Mr. Becken bought the entire stock, consisting of 18, 16 and 6 sizes in fine complete watches and also the patents on Paillard balance and hair springs, and as soon as practicable the entire line will be carried at competing prices, including a full line of material. Mr. Becken has received many compliments from his friends in the trade who appreciate that the name and watch of the Paillard Non-Magnetic Watch Co. are to live on in the future. All agree that the adjustment of a watch is valueless when in the presence of magnetism and that electric and magnetic influences have a much greater effect on the rate of a watch than either temperature, position, or isochronism. The Paillard non-magnetic movements are of the newest models, containing all the latest improvements, and have received the unqualified endorsement of the most renowned horologists, electricians, and scientists of the world, and for excellence of finish, beauty, strength, durability and accuracy as timekeepers are unsurpassed. Mr. Becken says that in this age of electricity there is a growing demand for non-magnetic high grade movements and that it will be his aim to cater to customers who are in business for profit rather than for sentiment and that he will see to it that jewelers can afford to please their customers and at the same time make good their guarantees. Consumers have always been ready to pay a good price for these movements and thousands now in the pockets of wearers speak volumes in their praise. They have withstood the most severe tests and exacting criticism, and to-day have a high reputation for timekeeping, under all conditions. Mr. Becken is one of Chicago's most progressive jobbers and was quick to see the business advantages to accrue from his recent great purchase.

**The Latest Patents.**

ISSUE OF JULY 7, 1896.

**563,268. PERPETUAL CALENDAR FOR**



WATCHES OR CLOCKS. JOHN D. FAZEL, Winfield, Kans.—Filed Mar. 6, 1893. Serial No. 464,830. (No model.)

**563,452. COLLAR-BUTTON.** EDWARD W.



CREECY, Washington, D. C.—Filed Feb. 14, 1894. Serial No. 500,146. (No model.)

**564,456. BUFFING-WHEEL.** WALLACE H. DIVINE, Utica, N. Y., assignor to B. H. Divine,



same place.—Filed Mar. 30, 1896. Serial No. 585,391. (No model.)

**563,534. WATCH-HOLDER FOR CONDUCTORS, MOTORMEN, &C.** RICHARD S. WILES

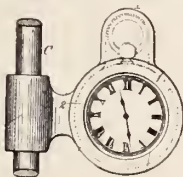

and HENRY A. GROUX, West Orange, N. J.—Filed Apr. 20, 1896. Serial No. 578,095. (No model)

**563,566. NAPKIN-HOLDER** NICHOLAS F.

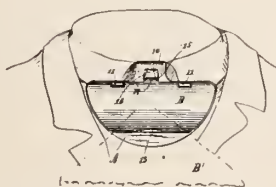

CLARKSON, New York, N. Y.—Filed Apr. 20, 1896. Serial No. 588,351. (No model.)

**563,618. CLOCK PENDULUM.** CHARLES M. RHODES, Highland, N. Y.—Filed June 3, 1896. Serial No. 476,445. (No model.)

The combination with the oscillating escapement and its actuating mechanism, of an arm fixed to swing with the rocking escapement and a normally vertical

balance bar mounted near its center of gravity to vibrate and engaged with the said swinging arm to re-

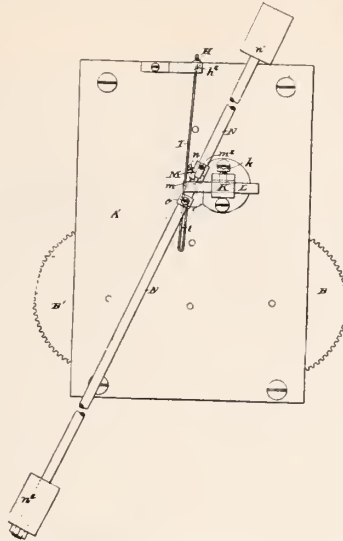

ceive an impulse in each direction of the vibratory movement.

**563,581. CASE.** EDWIN J. FLETCHER, New York, N. Y., assignor to the Witing Manufacturing

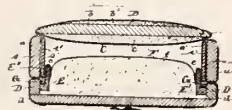

Company, same place.—Filed April 30, 1896. Serial No. 589,636. (No model.)

**563,717. OPHTHALMOSCOPE.** FREDERICH KNAUER, Wiesbaden, Germany, assignor to Emil B. Mey-

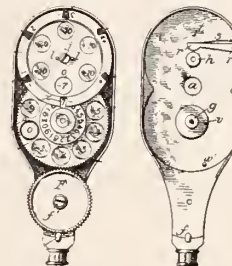

rowitz, New York, N. Y.—Filed Nov. 29, 1895. Serial No. 570,379. (No model) Patented in Germany Sept. 12, 1893, No. 76,518.

**25,752. BADGE.** AUGUSTUS B. ELLISON, St. Louis,



Mo.—Filed April 4, 1896. Serial No. 586,294. Term of patent 3½ years.

Mrs. T. S. Hoffman, wife of a prominent jeweler of Greensburg, Pa., last week drank a quantity of sulphuric acid in mistake for medicine. Every effort to save her life failed and she died last Tuesday night in the greatest agony. She was 64 years old.

The jewelry business of Kennon Mott, Brunswick, Ga., was placed in the hands of a temporary receiver last Saturday. Judge J. C. Lehman was appointed receiver. Mr. Mott claims that the receivership was the result of disputed accounts.

George German keeps a jewelry store at 639 Ocean Ave., Jersey City, N. J. He closed up at 9 o'clock on Friday and started for a spin along the Boulevard on his wheel. About an hour later the burglar alarm in his store began to work so vigorously that a crowd gathered in front of the store. Five policemen were about to break the door open when Mr. German arrived and unlocked it. A search of the establishment failed to unearth any burglar. A St. Bernard dog, which had been locked in the store, had stepped on a secret panel in front of the safe and started the burglar alarm.

**THE SIMPLEST STRONGEST AND BEST SKIRT SUPPORTER MADE.**



Twin Hooks Hold Skirt Waist and Skirt Immovably.

MADE OF A SOLID PIECE OF STERLING SILVER WITHOUT SOLDER.

Prices to the Trade in Plain Sterling.  
 1 in. \$5.00 per doz. | 1½ in. \$7.00 per doz.  
 1¼ in. 6.00 " | 2 in. 8.00 "

Rose Gilding, \$2.00 per dozen Extra.

Made in plain Sterling, Sterling Gilt and 14K Gold, of Heavy Weight, Only.

A VARIETY OF PATTERNS.

**THE TENNANT Co.,**

SILVERSMITHS,

33 Union Square, N. Y.

**NOVELTY.. Hat Guards.**

EVERY MAN WANTS ONE.

Sterling

Silver

.925 Fine

\$4.50

Per Dozen.

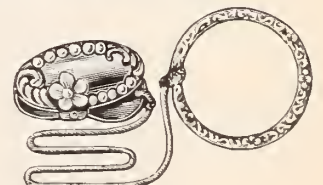

S. C. POWELL,

51 and 53 Maiden Lane, N. Y.

## EFFECT OF FREE SILVER COINAGE UPON THE SILVERWARE INDUSTRY.

Prominent Silverware Manufacturers and Dealers Express Decided Views on the Possibility of the Election of a Free Silver President.

Should the possibility of the election of William J. Bryan, on a free silver platform ultimately prove a reality, the industrial and commercial world in general would be affected to its very foundation. The silverware industry and consequently the jewelry business generally would be affected in a double sense, for they consume a large part of the silver used in the industrial arts. In order to learn how the silversmiths and jewelers feel on the subject, a letter, of which the following is a copy, was sent just after the nomination of Mr. Bryan, to a number of prominent silverware manufacturers and dealers:

New York, July 10, 1896.

Gentlemen:—We would like to publish your opinion as to the effect upon the Silverware Industry, the election of a Free Silver President would have.

The aggregation of these expressions of opinion from the entire silverware industry may be used with great effect in the campaign, for or against, depending upon the consensus of opinion.

You may make your communication as long as you desire.

Yours truly,

The Jewelers' Circular Pub. Co.

### TEMPORARY ADVANCE OF PRICES, THEN COLLAPSE.

NEWBURYPORT, Mass., July 11, 1896.

Editor of THE JEWELERS' CIRCULAR:

In all lines of legitimate business stability in values is desirable, even essential, if the best results are to be obtained.

It is generally conceded that the election of a Free Coinage Executive and Congress would result in a great advance in the price of silver bullion. Some eminent authorities insist that this advance could be but temporary, and would be followed by a collapse.

This is exactly what followed the enactment of the Sherman law, and we think that no one will now deny that the result was injurious both to the manufacturer and dealer.

Truly yours,

TOWLE MFG. Co.

### DISASTROUS TO THE SILVERWARE AND EVERY OTHER INDUSTRY.

PROVIDENCE, R. I., July 11, 1896.

Editor of THE JEWELERS' CIRCULAR:

We have your favor of yesterday stating that you would like to have an expression of our opinion as to what effect the election of a Free Silver President would have upon the silverware industry.

This subject we consider too weighty and too comprehensive to be discussed within the space of an ordinary letter, and besides, we feel that this important topic should be treated by abler hands than ours.

The writer has never claimed to be a prophet or the son of a prophet and he does not feel competent to hazard a prediction even, but lest he should be charged with timidity, he ventures to express his personal opinion, which is that of a firm believer in the gold standard, that the effect of the election of a Free Silver President, provided he should have a Congress to support him in the measures that he would be likely to advocate, would be disastrous not only to the silverware industry but to every other manufacturing interest in this country.

For the last 20 years we have been measuring values in this country by a gold yardstick, which we will assume is 36 inches in length. Should we change this standard to a silver yardstick 18 inches in length, which, in my opinion would follow silver mono-metalism, I believe that such a radical change would be disastrous to the business of the country. In my judgment it would not be alone the capitalist and the employer of labor who would have to face disaster, but the suffering entailed by this change of values would be felt most keenly by the farmer and wage earner.

My letter is already longer than I intended to write, and, in conclusion, let me express the hope that the things which we now fear will not come to pass. Yours truly,

HOWARD STERLING Co.

HIRAM HOWARD, President.

### GENERAL COLLAPSE AND RUIN OF THE SILVERWARE INDUSTRY.

PROVIDENCE, R. I., July 11, 1896.

Editor of THE JEWELERS' CIRCULAR:

In response to your letter asking our opinion as to the effect upon the silverware business the election of a Free Silver President would have, we would say that silver would rise in price and remain considerably higher for some months, perhaps for a year; this would take away what little profit there is in silver goods at the present time, as prices cannot be promptly regulated to new conditions. But before free coinage had been in effect 12 months, collapse would surely come, silver go down, gold would go up, and silver dollars would be worth something more than Continental and Confederate money; still, it would take two or three to buy a dollar dinner for a workingman's family.

The product of our mines, all the silver of Mexico, the tons and tons in the vaults of England, Germany, France and other countries would be sent here to be coined, and panic, ruin and bankruptcy would be the order of the day, and who in this then beautiful but God forsaken country would care to buy sterling manicure or toilet articles, or seven hundred other beautiful silver novelties even

if they do have the F. & B. plainly stamped on them, or any other stamp, in fact. The effect of the passage of a free silver bill would be ruin to all our industries, silverware business included. Yours very truly,

FOSTER & BAILEY.

### RUINATION TO THE SILVERWARE AND OTHER INDUSTRIES.

NEW YORK, July 11, 1896.

Editor of THE JEWELERS' CIRCULAR:

In my opinion the election of a Free Silver President would not only be disastrous to the silverware industry but nearly every other. The price of silver would have but little to do with it. I cannot understand how any sane business man, even if he were the owner of a silver mine, be he Democrat or Republican, can support any candidate on the Chicago platform. Very truly yours,

S. COTTLE,

of S. COTTLE Co.

### FREE SILVER COINAGE A GENERAL EVIL TO THE COUNTRY.

PROVIDENCE, R. I., July 11, '96.

Editor of THE JEWELERS' CIRCULAR:

In answer to your communication as to the effect upon the Silver Industry the election of a Free Silver President would have, would answer that we can not see where the Silver Industry would be affected any differently from all business that requires a sound currency for its basis. Stripping this silver question of all its glamour we find quite a number of silver mines closed. Since silver dropped from \$1.20 to 60 cents per ounce, the government when it stopped purchasing silver at the rate of 4 millions a month closed the working of a good many of these mines. These mines can produce silver from 60 to 100 cents per ounce, and under the free coinage act could have their product coined at a small expense to themselves, and as long as the long suffering public would carry them round for currency would be able to market their product; and there are those who are foolish enough to think that some day they may be able to get their silver dollars for almost nothing. There was never a greater fallacy. The laboring man always has the great burden to bear; if the currency is poor, he must be poor, for he can not afford to exchange it for gold; the loss is too great for him. When the great nations of the earth adopt gold as the base of their currency, we must, for while we have a great and good country we can not stand alone; we want the friendship, not the pity; the good fellowship and the grand interchange of the products of the world on an equality with the best.

The product of the silversmith must be sold on the market and his pay for his goods must be in the common currency of the country; and if that currency be debased below the level of other nations, then both the manufacturer and the employer must suffer whatever the loss may be to reach the value of his product in gold, for this is no experiment but a solid fact, and becomes so more and more every day. Russia is to-day putting

herself in a strong position on the gold side, and I am sorry to say, at our expense, for many of the gold dollars withdrawn from our vaults have found their way to Russia.

I can not but feel that the sober judgment of our people will assert itself this Fall and never for a moment harbor the idea that this country can stand alone in the fight with a currency that would be the ridicule and make us the laughing stock of all the strong nations. Respectfully yours,

FESSENDEN & Co.

#### PRICES WILL BE INFLATED FOR A TIME, THEN CRASH.

PROVIDENCE, R. I., July 11th, 1896.

Editor of THE JEWELERS' CIRCULAR:

In response to your request for our opinion as to the effect upon the silverware industry, by the election of a Free Silver President, we feel as all good business men must feel that have capital at stake, that it would result in a most disastrous calamity to our industry, as it would in all others.

We buy silver as a commodity, not as currency, and consequently it has its price fixed by the law of supply and demand, and while for a time by the act of a new Congress the price will be inflated, just as water finds its level, so will silver find its market value, and price; and we should value our goods in proportion, but when it does find its level, as a commodity, then it brings its own disaster as a currency, and when that time comes (God spare it), the worst financial panic will fall on this country that has ever been known. For we, as a United States, have no more power to set the legal standard of an inferior metal for a circulating medium than we have to say when the sun shall rise, and until we have an international agreement as regards the purchasing power of an ounce of silver, just so long must silver stand at its own intrinsic value to the only recognized standard of value that the world has ever known or will ever know, and that is gold. There can be but one standard as there is but one sun, one north star, and when the mariner can set his compass by two north stars then can we have two standards of value, and until that time comes we must accept the inevitable or go down with a crash in our foolish endeavor to get something for nothing.

Yours, W. H. MANCHESTER & Co.

#### NOTICE.

*Several of the letters received partake more of a political than of a commercial nature. We would desire those firms who intend to send replies to endeavor to give their opinions on the effects of the adoption of free silver coinage upon the silver ware trade, as users of silver bullion and sellers of silver manufactures.*

**Balance Spring.**—The balance spring is best placed upon a piece of glass, not too thick, which lies upon a piece of white paper, whereby the disturbing shadow is prevented altogether. Much twisting of the spring is injurious to it, as it is very difficult to time a watch with a bent spring.

### San Francisco.

G. Greenzweig has returned from a vacation trip in Napa county.

J. B. Klune, of Klune & Floberg, Sacramento, Cal., has been in town on business.

Reports from travelers through the Sacramento and San Joaquin valleys give encouraging prospects for a good trade this Fall. The crops in all except the southern portion of the State have been from one-third to one-half more than usual.

B. W. Freer, of the Waterbury Watch Co., has returned from a very successful trip of four months' duration through the Rocky Mountain and southwestern States. Harry E. Heacock, San Francisco manager of this company, sails for Honolulu on the 23d, to look after the company's interests in the islands.

Phelps & Adams are successors to Phelps & Miller, 118-120 Sutter St. This firm are managers of the San Francisco offices of the Gorham Mfg. Co., Middletown Plate Co., Rogers & Hamilton Co., E. N. Welch Mfg. Co., Parker Clock Co., Elgin National Watch Co., Larter, Elcox & Co., Martin, Copeland & Co., Kremenitz & Co., T. G. Hawkes & Co.

### Pacific Coast Notes

E. Meyben, Chico, Cal., has been quite ill the past month.

The son of T. M. Frye, Oakland, Cal., aged 23 years, died suddenly last week.

Judgment for \$1,000 has been granted against L. C. Hendrichsen, Portland, Ore.

A. C. Corwin, Stockton, Cal., has gone into partnership with C. H. Leggett, at Merced.

F. W. Carter, San Luis Obispo, Cal., has been making alterations and improvements in his store.

Walter Rose has been appointed assignee of the estate of S. E. Lucas & Son, jewelers, Los Angeles, Cal.

M. Saier, Fresno, Cal., has removed to a larger store from a location where he had been for 12 years.

Chas. Haas and Robert Haas, Stockton, Cal., have both been putting in fine new fronts in their stores.

H. J. Kuechler and J. Glick, Stockton, Cal., have consolidated their businesses and formed a co-partnership.

About 12 designs for the silver service for the United States battleship *Oregon*, have been submitted to the committee having the matter in hand.

A. Feldenheimer, Portland, Ore., furnished the Dosch gold medal awarded for the best essay in horticulture. Mr. Dosch is State Commissioner for Oregon.

J. L. McCulloch, Princeville, Ore., was married June 28th to Mrs. Jane Compton, daughter of E. M. White, a prominent and highly respected citizen of Oregon.

Yates Brothers, Milton, Ore., have an \$85 music box in their window, which will be given away by chance, to be decided by tickets allotted to each purchaser. It is proving quite an attraction.

A. F. Blackwell, formerly of Pittston, Pa., has opened a jewelry store in Avoca, Pa.

### Last Week's Arrivals.

**THE CIRCULAR has perfected arrangements for obtaining the names and hotel addresses of all the latest buyers visiting New York, and each day posts in its office, 189 Broadway, a bulletin which every member of the trade is cordially invited to copy.**

The following out-of-town dealers were registered in New York during the past week: L. Krower, New Orleans, La., at Albert Lorsch & Co.'s, 37 Maiden Lane; M. Bauman, St. Louis, Mo., H. Imperial; S. Illeh, Jr., Albany, N. Y., Grand Union H.; A. Dilsheimer, Philadelphia, Pa., Astor H.; J. Drukker, St. Louis, Mo., H. Imperial; M. J. Davidow, Scranton, Pa., Hoffman H.; G. H. Boehmer, St. Louis, Mo., Hoffman H.; W. Meckes, Cleveland, O., Westminster H.; L. Shuttles, Dallas, Tex., Astor H.; E. A. Dayton, Omaha, Neb., Astor H.; C. Hadenfeldt, San Francisco, Cal., Astor H.; W. J. Hammond, Detroit, Mich., Holland H.; J. K. Davison, Philadelphia, Pa., Broadway Central H.; L. J. McCollough, Pittsburgh, Pa., St. Cloud H.; S. W. McKim, jewelry buyer for Meinstock, Lubin & Co., Sacramento, Cal., 274 Church St.; J. Liepold, jewelry buyer for Liepold Bros., Selma, Ala., Stuart H.; B. J. Buren, jewelry buyer for Seelig, Buren & Co., Helena, Ark., 22 Howard St.; W. B. Ragland, Waco, Tex.; Mr. Adams (Phelps & Adams) San Francisco, Cal.; G. Weil, Danville, Pa., Union Square H.; H. L. Ide, Springfield, Ill., Sturtevant H.; E. Williams, Lynchburg, Va., Broadway Central H.; G. M. Tibbs, buyer, M. E. Smith & Co., Omaha, Neb., 338 Broadway; A. H. Bonnet, Columbus, O., Westminster H.; C. H. Knights, Chicago, Ill., Holland H.; J. M. Cutter, Chicago, Ill., Holland H.; A. I. DeRoy, Pittsburgh, Pa., Broadway Central H.; J. Bennett, Minneapolis, Minn., Grand H.; J. P. Trafton, Los Angeles, Cal., Astor H.; M. Eliasof, Albany, N. Y., Imperial H.

### Trans-Atlantic Voyagers.

#### TO EUROPE.

T. M. Knight, Philadelphia, Pa., was a passenger on the *Ems*, which sailed July 11th.

L. Tannenbaum, of L. Tannenbaum & Co., New York, left for Europe July 11th, on the *Etruria*.

#### FROM EUROPE.

Mr. Sinauer, of Oppenheimer Bros. & Veith, New York, has returned from Europe.

David C. Townsend, of E. Aug. Neresheimer & Co., New York, and O. L. Sypher, New York, were passengers on the *St. Louis*, which arrived last week.

The store of A. G. Baxter, East Troy, Pa., was entered by burglars a few nights ago, and jewelry, watches and other goods to the value of about \$200 were taken.

Z. J. Pequignot, Philadelphia, Pa., has rented a handsome residence for the Summer in Lansdowne, Pa.

## Our Traveling Representatives



Traveling representatives may consider these columns open for the publication of any news or items of interest regarding themselves or their confreres.

**M**R. WILLIS, representing the Gorham Mfg. Co., New York, and A. R. Dorchester, with Fessenden & Co., Providence, R. I., were in St. Louis last week.

The following traveling men registered in Pittsburgh, Pa., last week: J. B. Richardson, Wm. C. Greene & Co.; Frank Wood, Carter, Hastings & Howe; Mr. Dillon, Meriden Cutlery Co.; L. E. Fay, Kirby, Mowry & Co.

Among the travelers in Kansas City, Mo., last week were: E. O. Baumgarten, Pairpoint Mfg. Co.; Henry Freund, H. Freund & Co.; Robert J. Hillinger, for H. S. Stanton; G. W. Whiting, Belknap, Johnson & Powell; Edgar L. Brown, Riker Bros.; C. F. Coutts, E. G. Webster & Son; F. R. Horton, Carter, Hastings & Howe; Samuel Jacobson, Jacobson Bros.

Among the lonesome specimens of the jewelry traveler noticed in Syracuse, N. Y., the past week were: Carl H. Lebkuecker, Alvin Mfg. Co.; Edwin L. Mumford, Waite, Thresher Co.; William Guiler, Carter, Hastings & Howe; Mr. Heyman, Stern Bros. & Co.; Mr. Miller, Seth Thomas Clock Co.; F. S. Sherry, Jos. Fahys & Co.; Mr. Ellison, Parks Bros. & Rogers.

Included among the traveling men to visit Philadelphia, Pa., lately were: John Taylor, Kremetz & Co.; Charles Duffy, Enos Richardson & Co.; Charles Perret, Jules Racine & Co.; Charles Willemin, T. G. Frothingham & Co.; Frank I. Locklin, Unger Bros., E. B. Osborne, William Smith & Co., and Mr. Simpson, Riker Bros.

### Cyrille Duquet Assigns on Demand of Schwob Bros.

QUEBEC, Can., July 9.—Cyrille Duquet assigned yesterday on demand of Schwob Bros., Montreal. The assets are placed at \$12,448, which include a stock in trade valued at \$19,447, and immovable property valued at \$18,500. The liabilities amount to \$31,325, and the principal creditors are: Quebec Building Society, \$31,825; Schwob Bros., \$9,854; Banque Jacques Cartier, Quebec, \$1,175; Banque Nationale, \$1,700; Goldsmith & Frank, New York, \$1,503; Levy Bros. Co., Hamilton, \$1,045; Goldsmith's Stock Co., Toronto, \$717; Banque du Peuple, Quebec, \$700; Saunders, Saurie & Co., \$465; Smith, Patterson & Co., Boston, Mass., \$340; Henry Pearce, Montreal, \$331; Simpson, Hall, Miller & Co., Montreal, \$268, and Chanteloup Mfg. Co., Montreal, \$225. F. X. Gosselin, N. P., has been named provisional guardian.

### Detail Description of Tilden-Thurber Co.'s New Establishment.

PROVIDENCE, R. I., July 8.—This morning the Tilden-Thurber Co. threw open to the public the doors of their new store at the corner of Westminster and Mathewson Sts. for the first time. The proprietors feel justly proud of their fine establishment, which enables this city to compete in this respect with any store in the country. In point of convenience and artistic arrangement these new quarters cannot be excelled in New England. A handsome exterior, elegant and substantial fittings of the interior, high studded rooms, well lighted day and evening, and handsome stock and fixtures are but few of the noteworthy points about this new building.

For the purpose for which it is used this building is one of the finest in the country. The airy style of the two sides of the building fronting on Westminster and Mathewson Sts. is a good indication of what is revealed within. Four stories and a basement are in use by the firm, all fitted in a substantial style that shows no expense was spared. Fixtures throughout the structure were supplied by Service & Hoffman, Rochester, N. Y. On the first floor these are of mahogany and rosewood. The walls are of a blue tint, and the ceiling is in white, relieved by embossed festoons in gold. Large plate glass windows near the top of the walls easily swing open and insure almost perfect ventilation. The floor is devoted to precious stones, silver ware, shell work and the like. Around the sides of this floor are ranged cases of rosewood and plate glass, and in the central part is a continuous, elliptical shaped case of similar material. The Fletcher system of shelving is used in all the cases. In the rear of the store on the first floor is an alcove furnished in mahogany for silverware which is displayed in high upright cases. A feature of these cases is the ease with which the large plate glass doors may be raised. By themselves the doors would require four men to lift them, but by an ingenious system of balances, a child may raise one.

Three elevators, one for passengers, communicate with the different floors of the building. The staircase is at the rear of the building. On the first floor, near the staircase, is the engraving and repair department, situated in plain view in an easily approached location for the convenience of customers. Passing to the second floor, the cut glass and fine pottery department is encountered. Fixtures on this floor are in black walnut. The cut glass is arranged in cases with tops of mirror plate, which exhibits the beauty of the ware at its finest. In cases at the other side of the room are placed bronzes and porcelain wares from all parts of the world. Wares from France, England, Austria, Italy, China and Japan are in the list, representing an aggregate of thousands of dollars and containing many rare and very costly specimens.

The third floor is utilized for the dinner ware department, and in the rear for the ecclesiastical department, comprising church furnishings from the Gorham factory. Cases

of white and massive dining tables uphold the fine exhibition of dinner ware. The offices are on this floor, equipped with all that can facilitate office work. In time it is intended to use part of this floor for an Oriental section, where the rich and highly colored wares from the east may be inspected to advantage. The art galleries and the art department occupy the fourth floor, together with a space reserved in the rear for the workshops. Etchings, paintings and views are tastefully arranged in the art department, which is a harmony of quiet tones and dull colors.

The public art gallery is hung with terra cotta plush, with a divan of the same in the central portion, in whose comfortable depths the connoisseur may luxuriate for hours surrounded by the works of famous artists. Another gallery of smaller dimensions and of the same general tints is destined for private exhibitions or the exhibition of some especially noted works.

A pneumatic cash system, in which the pipes are hidden in the floor, is an introduction to be remarked. The building is also well protected against fire by a combination of the thermostat and the automatic sprinklers. The thermostat gives warning of an excessive increase in the temperature before the sprinklers are sufficiently heated to be set in motion, and also gives notice if the sprinklers are set off by accident. The exterior is noticeable for its substantial simplicity. It is of granite and brown stone with trimmings and facing of marble.

### Syracuse.

H. J. How has been confined to his home by sickness the past week.

Olin H. Bright, jeweler, Ithaca, has made a general assignment in favor of his creditors.

Wm. H. Lothrop, with Hitchcock & Morse, is spending his vacation at his home in Portland, Me.

Miss Watts, of Ann Arbor, arrived last Tuesday for a two week's visit with her brother, Herbert C. Watts, optician for Calvin S. Ball.

### Sipe & Sigler Must Pay Mrs. Shields instead of Vice Versa.

CLEVELAND, O., July 7.—Sipe & Sigler, jewelers, met with a loss in their suit against Mrs. Helen M. Shields, the wife of ex-County Treasurer Shields. The jewelry firm sued Mrs. Shields for \$500, and the jury, after having been out for two days, brought in a verdict for \$16.45 for Mrs. Shields on her cross-petition. Some time ago Mrs. Shields purchased about \$1,500 worth of jewelry from the firm, and she ordered the goods laid aside for her. It is said that part of the goods were delivered to her, but in the meantime she heard that the goods were not what they had been represented to be, and she refused to accept them. The suit commenced was to compel her to pay for them, and the jury turned around and declared that the jewelry firm owed Mrs. Shields money.

# The Jewelers' Circular

AND  
HOROLOGICAL REVIEW.

PUBLISHED EVERY WEDNESDAY BY

THE JEWELERS' CIRCULAR PUB'G CO.,

189 BROADWAY, NEW YORK CITY.

A JOURNAL DEVOTED TO THE INTERESTS OF JEWELERS, WATCHMAKERS, SILVERSMITHS, ELECTRO-PLATE MANUFACTURERS, AND ALL ENGAGED IN KINDRED BRANCHES OF INDUSTRY.

Member of the American Trade Press Association.

Our Editorial columns will contain our own opinions only, and we shall present in other columns only what we consider of interest or value to our readers. Advertising matter will not be printed as news.

Advertising rates in THE CIRCULAR are lower, considering the number of tradesmen reached by its large circulation, than in any other jewelry journal.

Notices of changes in standing advertisements must be received one week in advance; new matter can be received up to Monday.

## INFORMATION FOR SUBSCRIBERS.

### Terms of Subscription, Postage Prepaid.

United States and Canada, - - -	PER ANNUM.	\$2.00
Foreign Countries in Postal Union, - - -		4.00
Single Copies, - - -		.10

New Subscribers can commence at any time.

Payments for THE CIRCULAR when sent by mail, should be made in a Post-Office Money Order, Bank Check or Draft, or an Express Money Order or Registered Letter. All postmasters are required to register letters whenever requested to do so.

Pay money only to authorized collectors having proper credentials.

**Returning Copies** Returning your paper will not enable us to discontinue it, as we cannot find your name on our books unless your address is given.

**Changing Address.** In changing address always give the old as well as the new one. Your name cannot be found on our books unless this is done.

**Discontinuances.** We will continue to send papers until there is a specific order to stop, in connection with which all arrearages must be paid; but such an order can be given at any time, to take effect at or after the expiration of the subscription. All such orders will be promptly acknowledged by mail.

**Liability.** The Courts have decided that all subscribers to Journals are responsible until arrearages are paid in full and an order to discontinue has been received by the publisher.

## THE JEWELERS' CIRCULAR IN EUROPE.

Among the Places in Europe where THE JEWELERS' CIRCULAR is on file are the following:

**LONDON**—First Ave. Hotel, Holborn, E. C.; Holborn Viaduct Hotel, Royal Hotel.

**PARIS**—Hotel de L'Athéné, Rue Scribe.

**BERLIN**—Deutsche Uhrmacher Zeitung, Jager-Strasse, 73.

**GENEVA**—Journal Suisse D'Horlogerie.

**AMSTERDAM**—Continental Club, Hotel Amstel.

**ANTWERP**—Diamond Club, Rue de Pelican.

Vol. XXXII. July 15, 1896. No. 24.

Every line of reading matter in THE JEWELERS' CIRCULAR, with the exception of the few brief extracts from exchanges, always properly credited, is written exclusively for this journal. Each issue of THE JEWELERS' CIRCULAR is copyrighted. Permission to quote is extended to other publications, if such quotations are properly credited.

## Ten Years' Mineral Production in the United States.

An interesting tabular chart has been issued by the U. S. Geological Survey. In it we note that the production of precious stones has not fluctuated to any great extent during the last decade. In 1886 the value of precious stones found in the United States was \$119,056; in 1887, \$163,600; in 1888, \$139,850; in 1889, \$188,807; in 1890, \$118,833; in 1891, \$235,300; in 1892, \$312,050; in 1893, \$264,041; in 1894, \$132,250; in 1895, \$113,621.

The United States has not been a great yielder of platinum, but it is remarkable to note, however, that the value of the small amount of metal yielded has increased from year to year. In 1886, there were produced 50 ounces (troy), valued at \$100 or \$2.00 per ounce; in 1887, there was produced 448 ounces valued at \$1,838, or \$4.00 an ounce, in 1888, 500 ounces, valued at \$2,000 or \$4.00 an ounce; in 1889, 500 ounces, valued at \$2,000 or \$4.00 an ounce; in 1890, 600 ounces, valued at \$2,500 or \$4.16 an ounce; in 1891, 100 ounces valued at \$500 or \$5.00 an ounce; in 1892, 80 ounces valued at \$550 or \$7.00 an ounce; in 1893, 75 ounces valued at \$517 or \$7.00 an ounce; in 1894, 100 ounces valued at \$600 or \$6.00 an ounce; in 1895, 150 ounces valued at \$900 or \$6.00 an ounce. These values are interesting in comparison with those of gold and silver, the chart under consideration showing that the quantity of silver produced in 1895 was 47,000,000 ounces, (troy) of the coining value of \$60,766,300 or \$1.2929 per ounce, and of gold, 2,273,629 ounces of a valuation of \$47,000,000 or \$20.672 per ounce.

This table also evidences the wonderful progress that has been made in the processes for the production of aluminium. In 1886, 3000 pounds of the valuation of \$27,000 were produced; in 1887, 18,000 pounds valued at \$59,000; in 1888, 19,000 pounds valued at \$65,000; in 1889, including aluminium alloys, 47,468 pounds valued at \$97,335; in 1890, 61,281 pounds valued at \$61,281; in 1891, 150,000 pounds valued at \$100,000; in 1892, 259,885 pounds valued at \$172,824; in 1893, 339,629 pounds valued at \$206,903; in 1894, 550,000 pounds valued at \$316,250; and in 1895, 920,000 pounds valued at \$464,600. From these figures we see that the price of this metal, which at one time approached that of silver, has rapidly depreciated from \$9.00 a pound in 1886, to 50½ cents a pound in 1895, intervening values being \$3.27 in 1887, \$3.42 in 1888, \$2.05 in 1889, \$1.00 in 1890, 67 cents in 1891, 66 cents in 1892, 78 cents in 1893 and 57 cents in 1894.

THE conservatism of jewelers in general is the subject of constant comment among contemporaneous merchants in other branches of business; but in one respect the jewelers are notably progressive, namely, in the fostering and improvement of their organizations. In the consolidation of the Jewelers' Mercantile Agency with the New York Jewelers' Board of Trade by which the latter becomes the lessee of the credit reference book and directory

and rating facilities of the former, an organization results which in influence upon a trade generally, and in usefulness to its members particularly, is unequalled by any of its kind in any other industry. The New York Jewelers' Board of Trade, to-day, is the only body of its class in the industrial and commercial world, which publishes a complete and reliable credit rating reference book and directory. That this acquisition to the machinery of usefulness of the Board is proving successful is evidenced by the rapid increases that are being made to the membership of the organization.

## Seizures of Jewelry Upon the "Havel."

Special Agents Brown, Donohue and Murray, of the Treasury Department, made seizures of jewelry from three passengers on the *Havel* upon her arrival at the Bremen pier, Wednesday evening. One of the passengers was I. Friedman, of Dattelbaum & Friedman, manufacturers of rings, 4 Maiden Lane, New York, from whom 30 gold rings were taken. The Treasury agents claim that Mr. Friedman attempted to escape after paying duty on \$50 worth of presents, but was detained and the rings discovered in his pockets.

Mr. Friedman was seen at his office by a CIRCULAR reporter Thursday and admitted he was the man from whom the jewelry was taken, but said that the matter was all due to a mistake. The rings seized, he said, were samples and were worth but \$21. Before bringing them to this country he had questioned United States Consul Judd, at Vienna, whether or not they were dutiable. The consul, he said, told him they were probably not dutiable if brought in as samples, as he believed a manufacturer could bring sample goods to this country free of duty. Mr. Friedman says that he relied on this advice and paid duty on other goods he imported but did not think it necessary to declare the rings.

He intimated that it was ridiculous to suppose that a large firm like his would attempt to evade duty on \$21 worth of rings. The duty, he said, would be paid that day and the matter settled.

The other passengers of the *Havel* from whom jewelry was taken were: Otto Gallum, of Milwaukee, who had eight brooches, two gold watches, four gold chains and one pearl locket; and Louis Grunsinger, who had two watches, two rings, one scarf pin and one pair of earrings. All of the articles were confiscated and the men released.

The funeral of the late J. Kent Worthington, who died at Logansport, N. J., took place last Wednesday afternoon at Haverford, Pa. Mr. Worthington was a native of Hartford county, Maryland. He was educated at Westtown Boarding School, Chester county, Pa., and for a time was engaged in the wholesale jewelry business in Philadelphia. At the time of his death he was a stockbroker. He had been a member of the Philadelphia Stook Exchange since July 10, 1877.

### New York Notes.

A. Wallach & Co. have entered a judgment for \$264.79 against Freudenheim & Abramson.

E. I. Franklin & Co. have entered a judgment for \$209.22 against Newwitter & Rosenheim.

F. E. Leimbach has entered a judgment against Charles L. Krugler and Charles L. Krugler, Jr., for \$1,064.08.

The judgment for \$629.11 entered June 25th against Mordecai S. Kauffman by M. Goldstein, has been satisfied.

The engagement was announced last week of F. Kohn, wholesale jeweler, 37 and 39 Maiden Lane, to Miss Sophie Cahn.

Irwin French, assignee of the Rockford Watch Company, Rockford, Ill., has applied for membership in the New York Jewelers' Board of Trade.

The marriage of L. W. Rubinstein, 54 Maiden Lane, to Miss Cora Rice, of Niagara Falls, has been announced. The happy young couple left on the *Havel* for a short trip abroad.

A suit has been commenced in the Supreme Court by Erdman, Levy & Mayer on behalf of Fink, Bodenheimer & Co. to recover about \$2,400 from E. Wertheimer & Co., claimed to be due on two promissory notes.

B. M. Henschel, formerly with Marx, Veit & Co., has regained his good health and will soon call on his trade in the interest of S. C. Powell, maker of silver novelties and gold goods, 51 and 53 Maiden Lane, New York. Chas. Levy will soon call on his trade in the south in the interest of Mr. Powell.

John St., between Broadway and Nassau St., is soon to possess a new skyscraping edifice. The Anderson Estate has filed with the Building Department plans for a 12 story brick building to replace the five story structure now on the site of Nos. 12, 14 and 16 John St. The cost of the new building is placed at \$175,000.

At 3:20 o'clock on the morning of July 6, fire broke out on the fourth floor of the five story stone front building, 181 William St., in rooms occupied by John Mooney, and extended to the top floor to the premises occupied by Marshall & Gerard, watchspring manufacturers. Marshall & Gerard's loss is placed at \$200, covered by insurance. The cause of the fire is not known.

The new building on Wooster St., between 3d and 4th Sts., has been leased by George Borgfeldt & Co., at \$56,000 a year for 17 years. The lease is the largest negotiated in this city for many years. The building, which has just been completed by Gutwillig Bros. & Hirsh, is 11 stories in height and of fire-proof construction throughout. It occupies the entire block front, 210 feet, on the easterly side of Wooster St., and has a depth of 60 feet on 3d and 4th Sts.

At the regular monthly meeting of the board of directors held on the 9th inst., the following firms were elected to membership in the New York Jewelers' Board of Trade: M. B. Bryant & Co., Green Bros., David Marx, New York, and J. S. Voss & Son, Cincinnati, O. D. J. Mahony, manufacturer of silverware,

117 W. 28th St., New York, has applied for membership in the New York Jewelers' Board of Trade.

B. H. Merzbacher, a peddler of jewelry, committed suicide Thursday at Coney Island. Deputy Sheriff Whoriskey received a writ of replevin from Hays & Greenbaum for about \$1,600 worth of jewelry belonging to Koch, Dreyfus & Co., which was in the possession of Merzbacher. The sheriff found the goods called for in a case in Merzbacher's boarding house at 332 East Fifty-seventh St., consisting of diamonds, watches, chains, rings, pins, etc., which were seized under the writ.

Hamann & Koch, retail jewelers, 7 Maiden Lane, are offering \$500 for the return of a gray-black pearl, pear shaped, weighing thirty-nine grains, and set as a gentleman's scarfpin, lost by one of their customers. The name of the owner is withheld for personal reasons. The pin was missed only two or three days ago from a pin cushion, where the owner had placed it two weeks ago. Its value is placed at \$1,000. The reward will be given and no questions asked the person who returns it.

### Sheriff in Possession of the Business Rosenbush, Quitman & Aronson.

The sheriff Monday closed up the store of Rosenbush, Quitman & Aronson, wholesale jewelers at 487 Broadway, New York, on a confessed judgment for \$170 in favor of Epstein Brothers for services rendered. There was no stock of any account there, only the fixtures. Erdman, Levy & Mayer, representing two of the creditors, said they had obtained a bill of sale of the stock to secure Max Schlanger, of Boston, a creditor for about \$1,800.

The stock taken would not, they said, realize the amount of their claim. Accounts aggregating about \$1,900 have been turned over to Eisenstein & Rosenberg to secure a debt of about \$1,700, money loaned.

Mr. Mayer estimated the total liabilities of the defunct firm at about \$10,000 of which about \$6,000 was for merchandise due to creditors in Providence and Attleboro.

The firm were composed of David Rosenbush, Mrs. M. D. Quitman and Samuel Aronson, who recently started the Empire Jewellery Mfg. Co., but a few months ago changed the business into a partnership under the style of Rosenbush, Quitman & Aronson. Rosenbush and Aronson were both formerly employes of E. Wertheimer & Co.

PHILADELPHIA, Pa., July 6, 1896.

Editor of THE JEWELERS' CIRCULAR:

Can you inform us whether the engine of J. Schorrbacher, of your last issue, page 31, can be bought in this country? If so, where?

HESELPOTH & SMETHURST.

ANSWER.—Inquiry among the principal dealers in such machines fails to elicit the name of any one who handles it. Why not address J. Schorrbacher, Gaimersheim-Ingolstadt, Bavaria?

Elias M. Rothman, 139 Broadway, Cleveland, O., has made an assignment. The assets are \$10,000 and the liabilities \$16,000.

### Providence.

All communications for this column, addressed to P. O. Box 1093, Providence, will receive prompt attention.

S. C. Shurtleff & Co. have removed from 107 Friendship St. to 59 Page St.

Since the agitation of the silver question the price of the white metal has advanced in price here to 71 cents.

The Board of Directors of the Manufacturing Jewelers' Board of Trade will meet at their rooms Saturday afternoon, the 18th inst.

R. L. Griffith & Son will be one of the manufacturing concerns to remove to the new Metcalf building, Richmond, Page and Pine Sts.

Arthur S. Cumrefors is now with the Edwin Lowe Gold Plate Co. He was formerly for many years bookkeeper and traveler for E. N. Cook.

W. F. Main, Iowa City, Ia., has been in town on a visit to his manufactory at 67 Friendship St. He is getting out a handsome new line of goods.

Julius Stern, of Heilborn, Brandt & Stern, New York, and M. Weber, of Pichel & Weber, New York, called upon the manufacturers in this vicinity the past week.

Recent buyers in town were: L. Krower, New Orleans; D. Buxton, W. S. & D. Buxton, Springfield, Mass.; Mr. Skidmore, C. B. Rouss & Co., New York, and W. S. Shuttles, W. S. Shuttles & Son, Dallas, Tex.

The gold badges for the Providence City Council Fourth of July Committee were manufactured by Harvey & Otis, and were very handsome and appropriate. The bicycle prizes for the same occasion were made by Lewis Patstone & Co.

The trophy won June 22 by the New England Whist Association at the sixth congress, held at Manhattan Beach, N. Y., has been on exhibition the past few days in the window of the Tilden-Thurber Co.'s new store, this city. It was given by Brooklyn to the American Whist League to be played for by teams representing the auxiliary associations. The trophy is held subject to challenge. It is a fine piece of workmanship and design, made by the Gorham Mfg. Co., of this city. It is in the form of a shield, and is mounted on highly polished antique oak. The material is heavy bronze, with a scroll work design elaborately chased. In the center within the border of bronze is the seal of the City of Brooklyn and below this an enamel whist hand can be plainly seen. In the center is an inscription of presentation by Brooklyn to the American Whist League, and at the base is left space for the name of the winning association to be engraved.

UNION, IOWA, June 27, 1896.

Editor of THE JEWELERS' CIRCULAR:

Can you give us the name of the people who make a D. F. B. chain, warranted 10 years? The D. F. B. is stamped in the tag.

WARREN SMITH.

ANSWER.—The D. F. B. chain is manufactured by the D. F. Briggs Co., Attleboro, Mass.



## Special Notices.

Rates 75c. per insertion for notices not exceeding 3 lines (25 words); additional words 2 cents each. If answers are to be forwarded, postage stamps must be enclosed. Two insertions, 15 per cent. off; three insertions, 20 per cent. off; four insertions or more, 25 per cent. off. Payable strictly in advance. Display cards on this page will be charged at \$2.00 per inch for first insertion, subject to same discount as above for subsequent insertions.

Under the heading of **Situations Wanted** on this page advertisements will be inserted for **One Cent a Word** each insertion, no discount. This offer refers to **Situations Wanted only**. Payable strictly in advance. If answers are to be forwarded, postage must be enclosed.

## Situations Wanted.

Notices under this heading **ONLY** are charged at one cent a word, payable strictly in advance. If answer are to be forwarded, postage must be enclosed.

**WANTED.**—A position as salesman in a precious stone house; well acquainted in the trade; can give best references. Address Stones, care **JEWELERS' CIRCULAR**.

**POSITION** by young man to travel south and southwest with his father, who has had 10 years' experience; expenses and small salary. Address M. K., care **JEWELERS' CIRCULAR**.

**SITUATION WANTED** by first-class jeweler and engraver in first-class establishment; unquestionable references; permanent situation desired; north-west preferred. Address A., care **JEWELERS' CIRCULAR**.

**WANTED.**—Situation by a first-class jewelry jobber, diamond setter, fine clock repairer and good engraver; south or west preferred; first class references. Address Charles W. Stegman, 174 Dodge St., Cleveland, Ohio.

**WANTED.**—Position in wholesale or retail store by young man 25 years of age; have had seven years' experience in retail store and have managed one for the past three years; am first-class workman on watches, clocks and jewelry jobbing; also good salesman; best of recommendations. Address X. Y. 72, care **JEWELERS' CIRCULAR**.

## Help Wanted.

**WANTED.**—Experienced salesman to sell a fine line of solid gold stone rings on commission, to retail trade in New York and vicinity. Address O. M. C., care **JEWELERS' CIRCULAR**.

**WANTED.**—Two retail optical salesmen of good appearance, and capable of adjusting frames; references required. Address Accurate, care **JEWELERS' CIRCULAR**.

**WANTED.**—Experienced traveling salesman to handle best American line of spectacles through New York State and the East. Address Optics, care **JEWELERS' CIRCULAR**.

**WANTED.**—A first class jewelry salesman, one with an acquaintance with New England retail trade preferred, to carry a gold line; only those willing to work need apply. Address, stating age, experience, reference and salary, to R. P., care **JEWELERS' CIRCULAR**.

## Business Opportunities.

\$1,200 will buy my 6,800 lb. steel-lined safe, plate glass store fixtures and balance of my clocks and silverware; will sell watches and jewelry if wanted; best opening in Oklahoma for a live jeweler. Chas. E. Rose, El Reno, Oklahoma.

**FOR SALE** in Philadelphia, a desirable business in a fine locality; clean stock about \$8,000, which can be reduced if desired; walnut fixtures, fine regulator, safes, etc.; good run of work; established 12 years. Address O. E., care **JEWELERS' CIRCULAR**.

\$650.00 **SPOT CASH** buys fixtures, material and optical goods of leading jewelry and optical store; established 15 years; western New York; bench work \$1,500 per year; only optician; will sell any other part of stock if desired. Address J. O., care **JEWELERS' CIRCULAR**.

## For Sale.

**FOR SALE.**—Three notes aggregating \$105, together with interest, all of which are long overdue; will sell at a bargain; maker, E. E. Teape, jeweler, Canon City, Colorado. Address C. W. Little & Co., 32 Cortlandt St., New York.

## FOR RENT.

Large Office, 5th Floor - - **Corbin Building.**

Will let very low for Three Years.

APPLY, - - -

**JOSEPH FAHYS & CO.,**

NO. 54 MAIDEN LANE, N. Y.

## FOR SALE.

Two Fine Black Walnut Wall Cases, twelve feet long. Two twenty-four feet long. One twenty-five feet long.

These cases have vertical sliding doors, and were made by B. & W. B. Smith, and are in perfect condition.

**REED & BARTON,**

37 Union Square, New York

## Workshop Notes.

200 PAGES BOUND IN CLOTH.

The most complete book of the kind ever published.

A perfect encyclopedia of information.

With a copy of **Workshop Notes** and 52 numbers of **The Jewelers' Circular** (a year's subscription price,

\$2.00), any jeweler will have all the trade literature he needs.

**SEND \$2.50 AND GET BOTH.**



## A Loving Wife's Advice.

She urges her worrying husband, in order to increase his business, to read from week to week

**THE 20 DEPARTMENTS**

IN **THE JEWELERS' CIRCULAR,**  
PER \$2 00 YEAR

## Official Notice of the Combination of the Jewelers' Mercantile Agency and the New York Jewelers' Board of Trade.

Official notification of the lease of the business of the Jewelers' Mercantile Agency, Ltd. by the New York Jewelers' Board of Trade has been sent to the members of both associations through the following circular letters:

NEW YORK, July 7, 1896.

*Gentlemen:*—We are pleased to inform you that the leasing of the plant and business of the Jewelers' Mercantile Agency Ltd., by this Association has been completed, and all the papers in relation thereto have been executed; therefore for the present, our members and the subscribers to the Jewelers' Mercantile Agency, Ltd., (whose subscriptions have not expired) can, when they desire trade information procure mercantile reports from the Jewelers' Mercantile Agency, Ltd., 214 and 216 Broadway, Chicago, Ill., and Providence, R. I., as well as from this office; until such time as the two offices are consolidated into one; and the reports of the Agency and the Board of Trade condensed.

The Collection Department of this Association, is also at the service of the subscribers to the Jewelers' Mercantile Agency, Ltd., as well as to the members of this Association, and will endeavor to satisfactorily handle all business that is placed with it.

Yours respectfully,

N. Y. JEWELERS' BOARD OF TRADE,

A. J. G. HODENPYL, *President* (V).

H. M. CONDIT, *Secretary*.

NEW YORK, July 12, 1896.

*Dear Sir:*—In accordance with our circular letter to you of recent date, you are hereby notified that the business of The Jewelers' Mercantile Agency, Limited, has been leased to The New York Jewelers' Board of Trade.

Your contract with the Jewelers' Mercantile Agency, Limited, will be carried out in every particular as to use of Reference Books, Reports, etc., Mr. D. L. Safford remaining in charge.

The Collection Department of the Board of Trade is also at your service, and will endeavor to satisfactorily handle all business that is placed with it.

The greatly enlarged membership as a result of this consolidation, gives a much broader field for investigation as to credits, and must result in a much better service to the trade than any other agency can furnish.

At the expiration of your present subscription, we trust you will become members of the Board of Trade, and receive its many benefits in addition to what you have received from, Yours truly,

THE JEWELERS' MERCANTILE AGENCY, LIMITED.

D. L. SAFFORD, *Pres't.*

No jeweler or watch repairer should be without a copy of "**WORKSHOP NOTES**," a new and very useful book for the workshop. Send for circular containing a complete index of the book, and judge of its merits for yourself.

THE EMPIRE WESTWARD TAKES ITS WAY

# WESTERN SUPPLEMENT

## of THE JEWELERS' CIRCULAR

VOL. XXXII.

CHICAGO, WEDNESDAY, JULY 15, 1896.

NO. 24.

### Chicago Notes.

All communications in reference to the Chicago department of *The Jewelers' Circular*, addressed to S. Partin, 270 Garfield Ave., Chicago, will receive immediate attention.

Mr. Hitchen, of Landers, Frary & Clark, is on a vacation till August.

Mr. and Mrs. R. A. Kettle have returned from their eastern wedding trip.

Mr. Smith, of Reichenberg, Smith & Co., Omaha, Neb., will be here on the 15th.

A. Gahlenbeck, Pensacola, Fla., was here as a delegate to the Democratic National Convention.

Charles Hoefler, of Woodstock, Hoefler & Co., Kansas City, dropped in to chat with friends the past week.

W. Kinnea, a missionary for the Elgin National Watch Co., has returned to the city after a six months' absence.

Mr. Tompkins, G. W. Marquardt & Sons, is spending the week at Avon, Ill., and will return with his family Thursday.

Mr. and Mrs. G. W. Marquardt, Sr., are visiting their sons here. Miss Della Marquardt, graduated from Vassar, is spending the Summer with her brothers.

C. H. Knights left for Boston, Mass., Friday for a short visit to a brother and went thence to New York to attend the convention of jobbers of American watches.

H. S. Noyes, manager of Bates & Bacon's Chicago office, is expected back this week from three weeks of recreation and lobster fishing on the Atlantic coast.

During his absence in the east Mr. Loeb, of the Wadsworth Watch Case Co.'s Chicago office, was elected a member of the Lakeside Club, one of the swell South Side social organizations.

The engagement as announced of Harry Hahn, son of H. F. Hahn and for some time associated with his father in business, and Miss Kohn, daughter of Mr. and Mrs. Joseph Kohn. The marriage is set for October.

The condition of Mrs. F. J. Thearle, Jr., is somewhat improved and hopes are entertained for her complete recovery. While as yet feeling has not returned to the side afflicted by

paralysis, she takes nourishment and digestion is good.

C. C. Lavell, a jeweler of Racine, and a music dealer of that city occupy opposite sides of the same store. Mr. Wiegand, for several years with J. W. Spence, has formed a tripartite partnership with the first named parties and will prove a valuable member of the firm, being both a musician and a jeweler and capable of taking charge of either side of store.

Politics has been uppermost in the minds of the trade the past week by reason of the exciting scenes at the Democratic Convention; nevertheless, good buyers were in town in the persons of Mr. Bloomer, of Bloomer Bros., Clayton, Ia., who spent several days here; Mr. Hall, of A. F. Hall & Co., Janesville, Wis.; E. Kirchgiesner, Tecumseh, Ia.; G. F. Schmermond, Granville, O.; C. H. Reynolds, Alpina, Mich.; J. H. Schmidt, Clinton, Ill.; son of L. Beckman, Kendallville, Ind.; Mr. Egger, nephew of Albert Miller, Dundee, Ill.; Harry Harmon, Afton, Ia.; Dr. Palmer, Palmer & Taylor, Blair, Neb., and Ed. Moses, of G. N. & E. R. Moses, Great Bend, Kan.

The entire scheme of decoration in C. D. Peacock's new store is in strict accordance in its design as well as color treatment with the requirements and demands, as well as symbolic suggestions of the business. The tones throughout are blue green. To a certain extent a monochrome treatment is demanded. The central feature of the ceiling is a large painting of Benvenuto Cellini. This painting was executed by Charles Holloway, assisted by Emil Phillipson. To the north and south of it are two large circular paintings representing the lapidary and the watchmaker respectively, both on the same monochrome treatment as the central one, designed by Heinrich Meixner, and painted by him with the assistance of Mr. Phillipson. Unquestionably the crowning effects are the ten jewels designed and painted by Charles Holloway, representing in the first group the ruby, diamond, sapphire, moonstone, and pearl, and in the second group the topaz, emerald, amethyst, catseye and olivine. It is not alone that in each and every case the pose in itself would indicate the jewel, but also in

the adapting the peculiar color effects of each stone, giving it either the radiance or the density of the jewel represented. The wall frieze is of a most beautiful design. Although also kept in almost monochrome treatment, all the color effects of the peacock have been suggested, though kept sufficiently subdued so as not obtrusively to present themselves.

### St. Louis.

Henry Lowenstein, 1230 S. Broadway, who suffered to the extent of \$180 during the cyclone, has everything shipshape again.

J. F. Schmitt, 1500 S. Broadway, has had nightly auctions for a week past, disposing of a great deal of stock damaged during the recent cyclone.

Mrs. Isabella Falconer Massa, mother of Edwin Massa, died in Keene, O., on July 5. Her son was with her for two weeks before her death.

A. S. Aloe Co. will move from their present location, 514 Locust St., about Jan. 1, 1897, to 514 Olive St., where they will have larger quarters, and be much more centrally located.

F. W. Bierbaum, who was re-elected director of the Missouri Retail Jewelers' Association on the 8th inst., had other honors fall to him on the same day. He was likewise re-elected a director of the Northwestern Savings Bank, and his birthday fittingly rounded out the 8th of July.

M. Eisenstadt Jewelry Co. completed last week a beautiful gavel which will be presented to the National president at the convention of retail jewelers at Atlantic City, N. J., by the Missouri Retail Jewelers' Association. It is made of solid sterling silver, 925-1000 fine, handle and all. The gavel proper is surrounded by two bands made from 14k. gold. The following inscriptions are on it: Front, "Presented to the National Retail Jewelers' Association of the U. S., by the Retail Jewelers' Association of Mo., July 14, 1896;" reverse, "From bullion received from various assays;" top of gavel proper, coat of arms of the State of Missouri; reverse, trade mark of the N. R. J. A. It will go from St. Louis in a beautiful solid oak case.



**ASK YOUR JOBBER FOR  
S. O. BICNEY & CO.'S HIGH  
GRADE**

# CHAINS

**THEY EQUAL SOLID GOLD IN STYLE AND FINISH.**

NOTE TRADE-MARK.

**Detroit.**

R. J. F. Roehm, of Roehm & Son, was in New Baltimore, Mich., last week.

Frederick Drexel, wholesale jeweler, has returned from a wedding trip spent in the east.

H. Koester and L. Schaub, jewelers, attended the annual meeting of the Elks at Cincinnati.

Will Nisbett, jeweler, Grand Rapids, Minn., was in Detroit last week. He is making a tour a wheel.

W. A. Sturgeon, of Smith, Sturgeon & Co., accompanied by his wife, is making a trip through Thousand Islands.

The following traveling salesmen passed through Detroit last week: Mr. Barry, Larter, Elcox & Co.; and Mr. Moorhead, R. L. Moorhead & Co.

Levy Rubin, who has been closing out William W. Scott's jewelry stock at Saginaw, Mich., has concluded to locate in that city permanently in the jewelry business.

The following country jewelers were in the city recently purchasing goods: Charles Spencer, Cass City, Mich.; William L. Wilson, Port Huron, Mich.; and Leo. Gumberts, Gumberts Bros., Evansville, Ind.

George De Vol, a smooth fingered colored man, was arrested last week at the instance of Rudolph D. Carstens, jeweler, Grand Rapids, Mich. He went into the store and asked to look at a \$5 stick pin. Later a \$15 opal pin was found missing.

**Mrs. Emma Moritz Petitions for a Respite.**

NEW ORLEANS, La., July 8.—Mrs. Emma Moritz, engaged in the retail jewelry and optical business at 1,035 Canal St., has filed a petition in the Civil District Court, asking for a respite. She asserts that owing to the dullness of trade she finds herself with a large stock on hand, which she has not been able to dispose of as rapidly as expected; that debts have matured and are rapidly maturing and the proceeds of her assets are insufficient to meet these debts as they fall due; that she needs a delay in order to pay her creditors.

Petitioner further represents that she has ample assets and is solvent; that she desires a meeting of her creditors to grant her a respite of 6, 12 and 18 months, paying one third

of her indebtedness at each of said periods; that, in the meantime, all proceedings against her, as well as her property, be stayed.

**Indianapolis.**

John Wimmer, optician, lost a young daughter last week after a short illness.

Chas. W. Fogg, Keystone Watch Case Co., and Chas. A. Moore, Moore & Co., were in Indianapolis last week.

F. T. Warring, Bluffton, Ind., now has associated with him H. L. Baker, recently doing business in Reed City, Mich.

David Gribben, of Gribben & Gray, N. Illinois St., received a serious injury in falling from his bicycle last week. He is still confined to his bed.

Wm. T. Marey has displayed in his window the badge and the jewel of the Surgeon Major of the Red Cross Association of England, recently presented to Dr. R. C. Kelsey, of Indianapolis.

**Pacific Coast Notes.**

Mrs. Edward J. Pierpont, wife of E. J. Pierpont, jeweler, Tucson, Ariz., committed suicide June 25th. She was about 23 years of age and went west with her husband from Naugatuck, Conn., nearly two years ago. She was a consumptive and committed the rash act through despondency.

J. B. Patterson, jeweler, Riverside, Cal., has been sent to jail for contempt of court in failing to comply with an order to pay alimony to his wife, pending the trial for divorce now being prosecuted by Mrs. Patterson.

**THE PERFECTION SHOW CASE**

FOR FINE JEWELRY TRADE.

WE CHALLENGE THE WORLD TO PRODUCE ITS EQUAL.



IF YOU ARE INTERESTED IN SHOW CASES AND JEWELRY FURNITURE, WRITE US FOR FULL INFORMATION.

**A. H. REVELL & CO.,**

431 to 437 Fifth Avenue, Chicago.

**PARSONS & SCHOOL**

FOR WATCHMAKERS,

PEORIA, ILL

Send for Circular and Terms,

**PARSONS & CO.**

**ONE**

Agent wanted in every town to sell the

**STRICTLY HIGH GRADE**



**\$100.00 BICYCLES**

Write for Catalogue and Agents' Terms.

Send 10 Cents for Elgin King Scarf Pin.

Address Department B,

**ELGIN CYCLE CO.,**

ELGIN, ILL.



**STERLING SILVER.**

**Colonial**

**JEWELERS ONLY.**



CONFECTION SPOON.

**TOWLE**

MANUFACTURING COMPANY,

NEWBURYPORT,

CHICAGO.

MASS.

A. Steffanoni, Oakland, Cal., has compromised with his creditors at 50 cents;  $\frac{1}{3}$  cash,  $\frac{1}{3}$  three months and  $\frac{1}{3}$  six months in endorsed notes.

### Cincinnati.

Charles Swigart, a brother of Eugene and John Swigart, will travel next season for Albert Bros.

Clemens Oskamp received the order for the magnificent jewel presented to Geo. B. Cox by the order of the Elks.

Albert Bros. have a pretty little novelty which they will use when the season opens. It is a cut glass pepper and salt set on a tray with a tiny silver spoon, the whole selling for 25 cents.

Jas. Wilson, who was arrested in Rochester, N. Y., and brought back to Cincinnati by H. A. Dodt, the Arcade jeweler, for obtaining jewelry to the amount of \$125 on false pretenses was dismissed on a compromise.

Bloom & Phillips, manufacturers' agents, have their new books containing the photographs of their new lines and will start out next week to see their customers who are inquiring about the new goods. They are the sole agents also for the hand painted ivory and celluloid triple mirrors, manufactured by the Dennison Mfg. Co.

The O. E. Bell Co. are equipping their fourth floor for a manufacturing jewelers' department. They have engaged a well known man who was at the head of a one-time big jewelry concern in Cincinnati, and who will

take charge of the factory, which will engage in the manufacture of jewelry, do all kinds of repair work and do ordered work.

Visitors in town last week were: N. Klein, Muncie, Ind.; John Selbert, Frankfort, Ky.; Dr. LeFevre, Hillsboro, O.; Fred Nagel, Paducah, Ky.; J. B. Settle, Bowling Green, Ky.; E. M. Hilton, Nicholasville, Ky.; B. Krummeyer, Evansville, Ind.; Jack Bitterman, of Bitterman Bros., Evansville, Ind.; J. L. Thuman, Evansville, Ind.; Henry Dehnell, Sandusky, O.; M. Schaub, Detroit, Mich.; John Abels, Dayton, Tenn.; W. Smith, Parkersburg, W. Va. They were in town for the Elks' big convention.

Cincinnati was given over entirely to the Elks last week. The merchants vied with each other in decorations. The Arcade was a bower of red, white and blue. The jewelers made a special effort to adorn their stores. The travelers who were home entertained and assisted in receiving the great crowds. Oskamp, Nolting & Co. presented a large bronze elk, three feet high, to the lodge making the best appearance in the parade, the Terre Haute members carrying off the prize. The bronze elk was displayed in Oskamp, Nolting & Co.'s window all week and drew large crowds around it.

### Kansas City.

A. L. Hosmer is selling out his stock at 716 Walnut St.

T. J. Furner has opened a jewelry store at 918 Main St., a very good location.

H. F. Wells, Woodstock, Hofer & Co., has started out on an extended western trip; Gus Lyons is in Iowa for M. Benjamin.

The stock of R. Michaels & Son, who failed recently, is being sold at public auction by B. Stern & Co. Emil S. Pollak, the trustee, is managing the sale.

The following out-of-town buyers were in the city last week: E. B. Van Ness, Mound City, Kan.; O. Kolstad, Pleasant Hill, Mo.; I. Eller, Richmond, Mo.; Chas. Wallgas, Galena, Kan.; Amos Plank, Hutchinson, Kan.; E. Hostetter, Garden City, Mo.; E. S. Gregory, Gallatin, Mo.

Alex Levin, Milwaukee, Wis., has assigned. Elias A. Biggs, Williamsport, Ind., has been sold out.

E. Smith, Duluth, Minn., will open a branch store in Virginia, Minn.

The New York *Evening Telegram* of July 8th contained a two column article with illustrations of the factory of the United States Cycle Co., giving the history of the "Regent" bicycle made by this concern, and the rapid growth of its popularity the past two years since the factory became the property of R., L. & M. Friedlander, 30 Maiden Lane, N. Y.

### HIS HAPPIEST MOMENT.

"What was the happiest moment of your life?"

"It was the moment when the jeweler took her engagement ring back and allowed me half price for it."—*Cleveland Leader*.



No. 1004 and 1008. Closed.

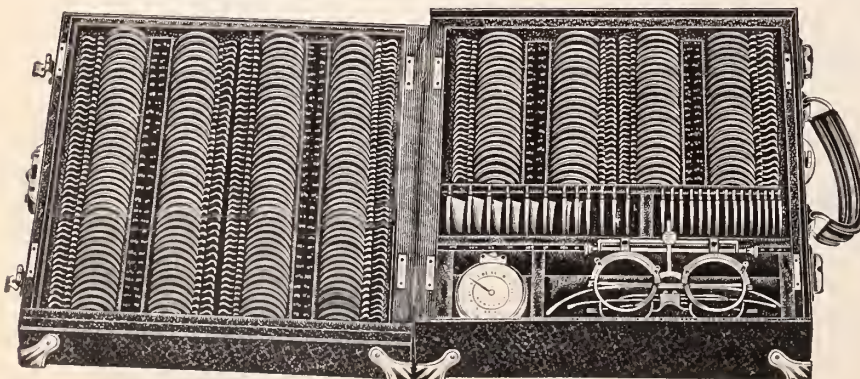

NEW STYLE FOLDING TRIAL CASES. No. 1004 and 1008. Open.

SEND FOR CATALOGUE AND MENTION JEWELERS' CIRCULAR.

"ALWAYS AHEAD"  
OTHERS FOLLOW.

# Geneva Optical Company,

67-69 WASHINGTON ST., CHICAGO.

## New Catalogue Now Ready.

**NEW PRICES**  
**NEW INSTRUMENTS**

For Oculists and Opticians.

Prescription Work to Order,  
Promptly and Accurately.

# PAILLARD NON-MAGNETIC MOVEMENTS

## WILL BE SOLD AT RECEIVER'S PRICES FOR THE NEXT 60 DAYS.



18 Size, Paillard Non-Magnetic. Open Face only.

**No. AA Extra.** Nickel; 15 fine ruby jewels in gold settings; adjusted to temperature, isochronism and five positions; Breguet hair spring; patent micrometer regulator; double sunk dial; handsomely damasked and finely finished throughout.  
Regular price, \$25 00    Cut price, \$15 00



18 Size, Paillard Non-Magnetic. Open Face only.

**No. A.** Nickel; 15 ruby jewels in gold settings; adjusted to temperature, isochronism and three positions; Breguet hair spring; patent micrometer regulator; gold screws; double sunk dial.  
Regular price, \$18 00    Cut price, \$10 00



18 Size, Paillard Non-Magnetic. Open Face only.

**No. B.** Nickel; 15 ruby jewels in gold settings; adjusted to temperature, isochronism and three positions; Breguet hair spring; patent micrometer regulator; double sunk dial.  
Regular price, \$14 00    Cut price, \$8 00



18 Size, Paillard Non-Magnetic. Open Face only.

**No. C.** Gilded; 15 ruby jewels in gold settings; adjusted to temperature, isochronism and three positions; Breguet hair spring; patent micrometer regulator; double sunk dial.  
Regular price, \$12 00.    Cut price, \$6 00



16 Size, 3-4 Plate, Paillard Non-Magnetic. Hunting and Open Face.

**No. 71.** Nickel; 20 finest quality red ruby jewels in gold settings; jeweled center; full cap jeweled escapement; Breguet hair spring; accurately adjusted to temperature, isochronism and all positions; micrometer regulator; double sunk dial; finely damasked and finished throughout.  
Regular price, \$50 00    Cut price, \$25 00



16 Size, 3-4 Plate, Paillard Non-Magnetic. Hunting and Open Face.

**No. 72.** Nickel; 18 fine ruby jewels in gold settings; center jeweled; cap jeweled escape wheel; Breguet hair spring; accurately adjusted to temperature, isochronism a.d six positions; micrometer regulator; double sunk dial.  
Regular price, \$35 00    Cut price, \$17 50



16 Size, 3-4 Plate, Paillard Non-Magnetic. Hunting and Open Face.

**No. 73.** Nickel; 16 ruby jewels in gold settings; jeweled center; Breguet hair spring; adjusted to temperature, isochronism and four positions; micrometer regulator.  
Regular price, \$25 00    Cut price, \$12 50



16 Size, 3-4 Plate, Paillard Non-Magnetic. Hunting and Open Face.

**No. 74.** Nickel; 15 ruby jewels in settings; Breguet hair spring; adjusted to temperature, isochronism and three positions; micrometer regulator.  
Regular price, \$18 00.    Cut price, \$9 00

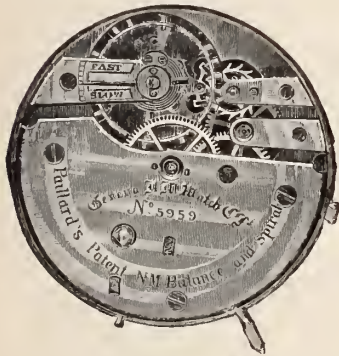

16 Size, Paillard Non-Magnetic. Hunting only.

**No. 61.** Nickel; 20 finest ruby jewels; center jeweled in gold setting; full cap jeweled escapement; adjusted to temperature, isochronism and six positions; micrometer regulator; Breguet hair spring; double sunk dial.  
Regular price, \$60 00    Cut price, \$30 00



16 Size, Paillard Non-Magnetic. Open Face only.

**No. 82.** Gilt; 15 jewels in settings; adjusted to heat and cold; Breguet hair spring; patent micrometer regulator.  
Regular price, \$12 00    Cut price, \$5 75

**No. 83.** Gilt; 11 jewels (top plate) in settings; exposed pallets; flat spring; straight regulator.  
Regular price, \$7 50    Cut Price, \$4 00

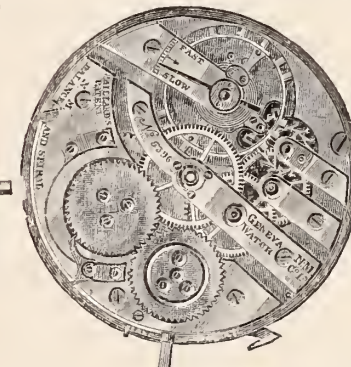

Monard Model. Paillard Non-Magnetic. Hunting only.

**No. 520.** 20 jewels.  
**No. 525.** 17 jewels.

These movements are all finely finished throughout; come in gold, filled or silver cases.

Write for our confidential net cash price.



Duret Model. Paillard Non-Magnetic. For Special Casing. Hunting only.

**No. 625.** 17 fine jewels; finely finished throughout; come complete in gold, filled or silver cases.

Write for our confidential net cash price.

# A. C. BECKEN,

## 103 STATE ST.,

## CHICAGO, ILL.

COLUMBUS MEMORIAL BUILDING.

## "Advertising for Jewelers."

AN ADDRESS DELIVERED BEFORE THE NATIONAL JEWELERS' ASSOCIATION, FOURTH ANNUAL CONVENTION, AT ATLANTIC CITY, N. J., BY NATH'L C. FOWLER, JR., OF NEW YORK CITY.

**Y**OU said, come.  
I came.

You asked me to tell you about what I think about advertising, and about what experience makes me think I know about advertising for jewelers.

If you agree with me, then follow me, for nobody objects to follow himself, or the man who thinks as he thinks.

If you don't agree with me, then try to learn advertising affirmatives from my advertising negatives.

What I say, in my own peculiar self-conceited way, may be kind enough to start the train of thought through the tunnels of your mind, and may stop it at the bumper of advertising.

Something to sell, a place of sale, somebody to sell it, and something to tell everybody where it is, and that is advertising, constitute the four links in the chain of business.

If everybody knows you have nothing to sell, or nobody knows you have something to sell, you will die for the want of what you haven't, or you'll die of the decomposition of what you have.

If the grocer and the market man, and the dealer in milk, must advertise the things which people must have, how much more must the man of luxury and semi-necessity tell the people that he has something to sell?

Nearly every jeweler advertises, and if these advertising jewelers are successful, and most of them are, it is fair to assume that success in jewelry needs advertising.

I do not mean to say that all jewelers of failure do not advertise, but I never knew a jeweler of success who did not advertise.

The advertising of jewelry not only tends to sell jewelry, but it stimulates a desire for the ornamental and beautiful.

Half the people do not know how inexpensive good jewelry is, and they do not realize the necessity of good time watches and good wear in silverware.

It is the business of advertising to educate the people into having what they can afford to have, and to appreciate the home brightening and stimulating power of beauty, convenience and ornament, and to know that the better class of luxuries are simply happy necessities.

The man with a poor watch may think he does not need a new one, or he may put off the buying of one.

It is the business of advertising to make the poor watch seem to be as bad as it is, and to preach the doctrine of promptness, and to connect these things with the watch you sell.

Half the women who can afford watches do not have them.

Advertising should stand as a disciple of equality, and declare that woman, as well as man, should be watched.

There are not half clocks enough in your town.

There should be a kitchen clock, a servant's clock, a dining room clock, a parlor clock, a hall clock, and several chamber clocks in every house of comfortable dimensions.

Too many clocks don't spoil the house.

Now is the time to have good time in every room.

It is the business of advertising to create an irresistible longing for clocks, and it should make the very walls of clockless rooms cry for time.

Let advertising show the people how ashamed the brass looks, peeping up from under its worn coat of white, and let advertising suggest that the new silverware will so brighten the table that the cheerful wife, by adding to the poor man's happiness, makes it easier for him to earn twice the money it costs.

Many a well-to-do family pays a big rental on the open ice pitcher, and more than enough to stand the cost of a silver one.

It is the business of advertising to put a silver ice pitcher on every sideboard.

Half the people don't wear glasses who ought to wear glasses, and philanthropic advertising benefits them, and makes money for you.

Most jewelers earn the most of their money preceding the holidays, and when the money-making days have passed, they virtually pull down the blinds of effort, sleep in the back of their stores, half awaking on the uneven hours, to snore a growl at the trade they haven't asked to come.

Dull times arrive with periodical regularity, but the dullest times are always in the store of the dullest jeweler, who cries hard times so much that he hasn't time to help change the times.

If people want a thing, they will have it, if they have the money to buy it with, and there is always some money in circulation, and the man who gets that money, whether he be a grocer or a jeweler, is he who keeps everlastingly at business, and continuously tells the people that he is after business.

Folks will not buy of the unsuccessful merchant, nor will they trade at the dull store.

People would rather be jammed in a crowd, in the store that is crowded, than buy the same thing in the store of vacancy.

The jeweler who doesn't advertise in dull times, simply announces to his local world that business isn't good with him.

It is the business of business to talk business, even when there isn't any business.

You have something to sell.

You want people to take it away from you for a consideration.

You want to sell that something more than somebody wants to buy it, and he who wants the most, must go the farthest to get it.

It is your business to meet the customer more than half way; yes, all of the way.

Advertising is the most convenient and economical means of going after a customer.

Advertising doesn't sell jewelry, for that isn't the business of advertising.

Advertising educates, suggests, creates desire, and assists the seller in selling.

Advertising is the accessory before the sale, and the salesman's ally.

Advertising brings the customer to the store, and leaves him there, and it is your business to keep him there, and make him exchange what he has for what you have.

The lazy jeweler wants advertising to do all the work.

Some jewelers expect good advertising to make up for poor clerks, and other jewelers expect poor advertising to assist good clerks.

A hundred dollar advertisement and a seven dollar clerk will sell about as few goods as a twenty dollar clerk and a seven dollar advertisement.

All the advertising in the world will not sell jewelry, or anything else, unless the goods are worth buying, and the clerks know how to sell them.

In good goods, good clerks, good stores, and good advertising, is good profit.

Don't advertise yourself as

<p>John Smith, Jeweler, 100 Smith Avenue, Smithville.</p>
---

Advertising like this may do good, so may the smooth bored gun bring down the enemy, but it hits by accident, and when it hits it may crush rather than penetrate its game.

The word "Jeweler" stands for everything in general, and for nothing in particular.

The jewelry establishment contains a conglomeration of metallic everything, and to sell those things it is necessary to advertise them one at a time, that each bright piece may shine in its own brilliancy, and that its rays may not be refracted by those from the other bright things beside it.

The would-be buyer of a watch knows that watches are sold by jewelers, but the word "Jeweler" does not suggest that his watch is worn out, or that he needs a new one.

The woman who wants a breast pin, or a ring, or anything else, does not find in the word "Jewelry" suggestion or advice.

A single diamond in your window looks larger than each of a dozen diamonds of the same size.

A single item in your advertisement stands out in the full strength of its identity.

An advertisement of a watch attracts all watch buyers.

An advertisement of a wedding ring interests all women, and will stimulate engagements.

An advertisement of clocks of every size and price may not sell a clock, for the clock buyer stands as a fool among many clocks, and chooses none, because he does not know which to choose.

An advertisement of a kitchen clock sells kitchen clocks, and the buyer who begins at the kitchen, may end at the attic.

An advertisement of silverware means nothing, but an advertisement of a silver spoon, stands for spoons, and fairly dips into the pocketbooks of spoon buyers.

The old conventional line, "Fine watch repairing," doesn't make people send watches to you, because it does not suggest the thought, but when you advertise, "Your watch needs

cleaning," or "Is your watch running right?" every reader instinctively thinks of his watch, and part of them will bring their watches to you.

The jeweler has no business to advertise generally.

The jewelry store is a store of specialties, each one standing by itself.

An advertisement of a silver thimble will sell thimbles, and it will bring to the store people who want cake dishes and other things.

If the advertisement brings people with money into your store, whether they come to buy a five cent article or a thousand dollar diamond, or even if they come for shopping purposes only, and you don't sell them, advertising isn't to blame, for the trouble is with you and yours.

Don't advertise your name in the largest type and what you sell in the smallest type.

You are not for sale, and until you are, advertise what you sell, not the people who sell it.

Put what you have for sale in the largest type, and let your name come at the bottom.

If people want your goods, they'll find you, even if your name is in the smallest type.

Advertise something new, or have your advertisement of something old so bright that old goods seem like new goods.

The local newspaper is the one great indispensable advertising medium, and all else is valuable when used in conjunction with newspaper advertising.

Finely printed circulars pay, and the higher the grade of printed matter, the more profitable it is.

The jeweler has no business to use the flyer and hand-bill.

Give people advice on the care of jewelry, and of watches and clocks.

Issue little booklets on how to make the clock keep time, and on how to take care of the watch.

Send out a circular, or little book on the polishing of silverware.

Offer to examine watches, and to regulate them, for nothing.

Become the local authority on jewelry in the broadest sense, and by giving away advice and suggestion add to your popularity.

Read your trade papers, and when you are through with them, give them to your clerks to read.

Every line of a trade paper contains something of interest to you, and every advertisement is news.

If the poorest paper of your craft was ten times as poor as it is, the poorest jeweler among you is not too poor to buy it, for among the chaff will be found kernels of wheat, and a line here and there will suggest, even if it does not inform.

Few people have an idea of what they want until somebody tells them, and often they do not purchase a thing until their mind slips the buying cog, and advertising is the only influence that can press back the gate of memory, and let out buying action.

The woman who wears one ring can be made to wear two rings, and the man who

finds fault with his boy, because his boy is not on time, can be made to buy a timepiece for his boy.

Advertise the accepted doctrine of promptness, and tell people that you furnish the means at so much per piece.

The man who has his watch cleaned every twentieth of a century can be made to bring you his watch every year.

You can become a business philanthropist.

You can make people prompt.

You can make their eyes see clearer.

You can teach them to admire the beautiful.

Advertising will do these things for you, and will keep constantly turning before the eyes of your people a sparkling jeweled panorama of gems of beautiful usefulness, and of home brightening glowing, and every time these pictures float before the public eye is seen your name, and folks learn of you, by your advertising, what they should have, and where to get it.

Make your store the shopping headquarters. Check bundles for nothing.

A little extra room you can generally spare, and a few chairs and a pitcher of ice water are not expensive.

Invite ladies to meet other ladies in your store.

Don't write "Welcome" on the wall or weave it into the mat, but let your atmosphere be impregnated with cordiality.

Politeness is a commodity of profitable proportion, and the man who is polite never needs to urge anyone to buy.

Advertise, and do not ask advertising to do more than advertising's share.

In the sense of advertising are the dollars of business.

**To Polish Steel.**—Take crocus of tin oxide and graduate it in the same way as in preparing diamond dust, and apply it to the steel by means of a piece of soft iron or bell metal made in proper shape, and prepared with flour of emery, the same as for pivot burnishing. Use the coarsest of the crocus first, and finish off with the finest. A better finish can be given to iron or steel than can be imparted by the use of polishing powders of any kind whatever. The German method of polishing steel is performed by the use of crocus on a buff wheel. Nothing can surpass the beauty imparted to steel or even iron by this process.

## WHAT THE JEWELERS' CIRCULAR CONTAINS and DOES.

- Matters in Jewelry Store Keeping** {
  - Makes your show windows a source of direct profit.
  - Makes your store a regular commercial enterprise.
  - Causes your business to be better known to your public
  - Keeps your business bright and up-to-date.
- Optical Department** {
  - Perfects you in your knowledge of optics.
  - Keeps you posted in new optical appliances.
  - Tells you how to make your optical dept. profitable
- The Connoisseur** {
  - Looks after your art goods department.
  - Informs you as to the latest products in china, pottery, cut glass and metal goods, etc.
  - Makes your experiment a success.
- Workshop Notes and Technical Articles** {
  - Posts you as to methods for doing all repairing jobs
  - Perfects you in your knowledge of Horology.
  - Perfects you in your knowledge of jewelry making and repairing.
  - Perfects you in your knowledge of watch repairing.
- Elsie Bee's Fashions** {
  - Tells you the leading fashions in Jewelry, etc.
  - Tells you what to buy and what to avoid.
  - Tells you what is salable and what is not.
  - Tells you what will be fashionable.
- News Gossip Editorials** {
  - Saves you from thieves by disclosing their tricks.
  - Saves you from burglars by showing the vulnerable points of a jewelry store.
  - Captures Malefactors for you by spreading accurate descriptions of them.
  - Saves you from failure by showing you why others fail.
  - Saves you from legal troubles by defining new laws.
  - Saves you from injudicious purchasing by telling you the fashions, state of trade, etc.
- Advice and Criticism Retail Advertising** {
  - Makes your newspaper advertising pay.
  - Teaches you in Pamphleteering.
  - Saves you money in your advertising account.
  - Eases the burden of advertisement writing.

BUYERS' INFORMATION BUREAU. QUERIES BY CIRCULAR READERS.

WORLD OF INVENTION.

All for **\$2.00** a Year. All for **4 CENTS** a Week.

## MATTERS IN JEWELRY STOREKEEPING.

That this department shall prove mutually beneficial to our readers, it is desirable that the members of the trade generally communicate with THE CIRCULAR regarding any advantageous device or plan that they are utilizing in connection with their business.

### Cash Register System for a Jewelry Store.

THE National Cash Register Co., Dayton, O., are publishing a large number of pamphlets describing various systems for taking care of transactions which occur between clerks and customers in a retail store. One of these pamphlets, entitled "System No. 293, for Jewelry Stores," is just



THE NO. 79 NATIONAL CASH REGISTER.

printed upon the detail strip, so that it may be checked up. Indicators showing the amount of the sale appear, and a bell is rung to call the attention of the customer to this indication. The amount being also printed upon the check makes it impossible for any mistakes to occur, in handling cash sales, without immediate detection.

Credit sales are taken care of in the same way. When goods are sold on credit the clerk fills out the small red "charge" slip, writing in the name, date, items and amount. He takes this to the register, presses the red "charge" key and turns the handle, and puts the slip in the drawer. He puts the check which is issued upon a "charge" pin file. A record of this transaction is made upon the detail strip, so that the "charge" slips may be checked up from this strip; also from the checks on the pin file.

Cash received on account and paid out is taken care of in the same way, different colored slips being used for each transaction. When a coin or bill is to be changed the clerk presses his initial key and turns the handle. The check which is thrown out he puts upon a "no sale" pin file. The check shows the clerk's initial and three "zeros" thus indicating that the drawer has simply been opened by this clerk to make change.

In retail stores there are but five transactions, which can occur between clerks and customers: Cash sales, credit sales, cash received on account, cash paid out, changing a coin or bill as an accommodation. All of these the register takes care of in exactly the same way.

The machine is an automatic cashier, which is always in its place ready for business. It facilitates every transaction, works fast, and makes no blunders. No matter in what part of the store the proprietor may be he can tell by the color of the indicators, which correspond with the color of the different slips (the cash indicators being white), what has been done by a customer leaving his store. At the close of the day's business the adding wheels of the register will show the total amount of the cash sales.

The number of checks on the "charge," "received on account" and "paid out" pin

files will show the number of "charge," "received on account" and "paid out" transactions, and the checks on the "no sale" file the number of such transactions. The detail strip will show each transaction as it occurred. The company guarantee the mechanical accuracy of the register.

**Examine Escapement Pivots.**— See that the pivots of the parts of the escapement are well polished, of proper length to protrude

CHARGE.	
<i>Feb. 25 1896</i>	
<i>R. Kevin Brumbaugh</i>	
<i>one ring</i>	15
<i>R.</i>	

THE CHARGE SLIP.

through the holes, and neither bull headed nor taper. A conical pivot should be conical only as far as the shoulder; the part that runs in the hole must be perfectly cylindrical. A pivot must have perceptible and equal side shake, or, if any difference be made, the pallet pivots should fit the closest. Both balance staff pivots should be of exactly the same size. The end shakes should all be equal. Bad pivots, bad uprighting, excessive and unequal shake in the pivot holes are responsible for much of the trouble experienced in position timing. With unequal end shakes the pallet depth is liable to be altered, owing to the curved form of the pallet faces. The action of the escapement will also be affected if the end shakes are not equal by a banking pin slightly bent, a slight inaccuracy in up-righting and other minor faults. The infinitesimal quantity necessary to derange the wheel of end pallet action may be gathered from the fact that a difference of 0.002 of an inch is quite enough to make a trifling pallet depth or correct depth quite unsound.

4317 FEB 25
GEO. A. CUTTING, Jeweler.
This Check Good for 5% in Trade. YOU PAID.
A 6.50

THE TICKET.

out. It is gotten up in a very attractive form, and is beautifully illustrated with cuts of checks, order slips, registers and the different key arrangements. The system is very elaborately described at length. In brief it is as follows:

A No. 79 total and detail adding and check-printing register is used. The keys are arranged to make a separate record of repairs, "charge," "received on account" and "paid out" transactions and to print the initials of the clerks on the checks and detail strip. The system can be used with or without a rebate check. When cash sales are made the clerk presses his initial key and the keys showing the proper amount, and turns the handle. Upon the check which is automatically thrown out into a receiver is printed the consecutive number of the sale, the date, the owner's business card, an agreement for rebate if desired, the clerk's initial and the amount of the sale. The amount is totally added upon the adding wheels, and also



**Workshop Notes.**

**Gravers.**—Gravers must be of good steel, complete, properly tempered, sharpened to hold the point, with a good common sense handle, all ready for use, of different shapes and sizes, but all should be first-class. They will prove better than poor ones as a gift, even if they seem to come too high. It will pay to get the best.

**Qualities of a Drill.**—A drill may be asserted to be good if it satisfies the following conditions: The point must be in the middle of the blade; it must be made of good steel that is carefully hardened, without being heated to the proper temperature; and it must be quite true—in other words, in rotating it must run with such trueness throughout the entire length that it will stand the end pressure required to cause it to bite, and will not bend.

**Polishing Broaches.**—These are usually made of ivory, and used with diamond dust, loose, in place of having been driven in. Oil the broach slightly, dip it into the finest diamond dust, and work it into the jewel the same as you would the brass broach. Unfortunately, too many watchmakers fail to attach sufficient importance to the polishing broach. The sluggish motion of watches nowadays is more often to be attributed to rough jewels than to any other cause.

**Using a Large File.**—Many watchmakers seem afraid of a large job, thinking, as I remember a red-ink contributor saying in a trade journal, it detracts from the poetry of watchmaking to use a large file. To such I would say, some portions of your work must commence coarse, no matter how fine you may finish it. For large turnings one needs a good sized band from the foot wheel, and that drawn pretty tight, as it is important to do work rapidly and cut a good sized chip, which cannot be done unless you have the power.

**Cleaning Soap for Metals.**—A German technical paper publishes the following receipt for the preparation of a cleaning soap for bronze and silverware: 50 parts finely cut cocoa soap is, by heating, dissolved in a sufficient quantity of water to form a thick paste; again, five parts crocus are stirred up with a little water, and 1½ parts carbonate of ammonium are mixed with it and stirred into the soap paste after cooling. The obtained paste is preserved in a stone jar, well tied with a bladder or parchment paper.

**To Turn the Taper.**—The taper to which staffs and pinions are turned are usually about the same, although in foreign watches the arbors of pinions are usually cylindrical and have no taper, but in American watches the wheels are set on a hub which is driven on the arbor, and for this reason most American pinion arbors are made about the same taper as we find in balance staffs; consequently we can use the same slips for grinding and polishing pinion arbors as we do for balance staffs. In such cases when pinion arbors are cylindrical, a slip exactly square is to be used.

**Centering a Chuck.**—In centering a chuck the greatest care must be exercised. The center should be accurately caught with a finely pointed graver, while the lathe is in motion, which should be braced on the T-rest brought up to just about on a line with the center of chuck, and directly across its face. A very small dot is about all that is really required, but a very small center is at times quite difficult to find. The writer makes a center of a rather shallow V-shape, always making sure that the bottom is absolutely central, so that it will hold the finest pivot. These finely cen-

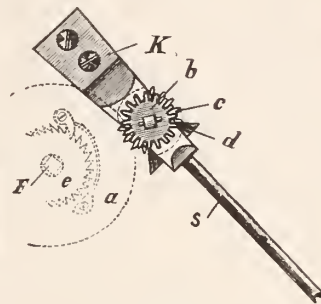

Fig. 1.

tered chucks are only necessary when centering the pivoted end of a finished or partly finished staff.

**The Ingold Fraise.**—As is known, the Ingold fraise is a pinion shaped cutter for correcting inaccuracies in the shape of wheel teeth, invented by Ingold, a Swiss watchmaker. It consists really of a hardened pinion, with square, sharp points. The fraise is gradually brought into depth, in a specially arranged depthing tool, with a wheel the teeth of which are incorrect, and rotated by means of a ferrule and bow. The fraises do not supersede the rounding-up tool, but may often be used after it with advantage, for if a wheel contains any thick teeth, they would not be corrected in a rounding-up tool which also of necessity leaves the teeth slightly hollow. The fraises cut the teeth into the direction they move on the pinion in working, and therefore leaves a surface which works with the least friction.

**Use of Drip for Drills.**—It must not be forgotten that: 1. If a drill is drilling too rapidly it will heat, and thus become softened as though too much tempered. It is with a view to prevent this that, when operating upon iron or steel, many workmen now and then dip the drill into a cold liquid (turpentine is good for this purpose), dry it and resume drilling, the hole being liberally supplied with oil. 2. When a blade is left too hard, or if the cutting edge be too acute, or if a feather edge has been left by the oilstone, small hard particles that are detached from the drill will imbed themselves in the hole. This will especially be the case if it is worked too rapidly, or with jerks. Such particles render the operation of drilling very slow and difficult. 3. For a given throw of the bow, the velocity increases as the diameter of the ferrule is reduced, and the force applied increases with this diameter and the tension of the strings on the bow.

**Device for Winding Wall Clocks.**

THE necessity of using a chair or steps for winding high hanging wall clocks is a great inconvenience for people loving ease and comfort. A German inventor has therefore devised a winding mechanism by which such a clock can be wound from the ground.

Fig. 3 is a side view of the mechanism, Figs. 1 and 2 are front views of the principal parts, naturally on a diminished scale. *p*, Fig. 3 is the back plate, *f* the barrel arbor, somewhat prolonged backward. Upon the pro-

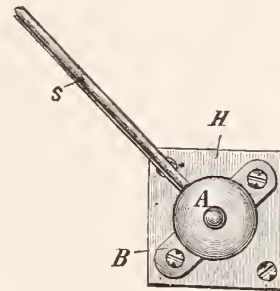

Fig. 2.

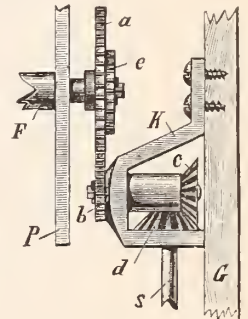

Fig. 3.

longation of this arbor is fastened with a revolving motion upon a round pivot a wheel *a*, and behind this, but upon a square, a maintaining-power wheel *e*.

To the back wall, *G*, of the clock case is screwed the bridge *K*, in which lie in bearing two arbors. The one, a short arbor, is in front furnished with a small toothed wheel *B*, behind with a conical pinion *c*; the former depths into the large toothed wheel *a*, the latter with a second conical pinion *d*.

The arbor of this latter is prolonged into a rod *s*, about 1-2 yards long, which passes through the side of the case and leads (see Fig. 2) to a wooden piece of board fastened to the wall of the room. Upon this board lies with the bridge *B* a second pair of conical wheels (similar to those in Fig. 3), which end in a turned wooden knob *A*. When this is rotated, the pinion *b*, Fig. 1, and with it the wheel *a* must rotate.

The illustrations show the mechanism for a clock with striking train, because in this instance only is it necessary to have the maintaining power *e*. In clocks with simply a going train the wheel *a* can hit direct upon the barrel arbor. If there is a striking train, a wheel with maintaining power is also placed upon the barrel arbor, and then placed with an intermediate wheel into depthing with the wheel *a*. When now the button *A* is revolved to the right, the going train is wound, as the click takes the ratchet wheel *e* along; the wheel of the striking train goes empty during this time. When, however, the revolution is to the left, the click of the going work slides backward over the ratchet teeth, and the wheel *a* moving empty upon the arbor *F* winds the striking train.

The jewels worn both abroad and at home are growing apace in gorgeousness, especially the finger rings, corsage ornaments and decorations for the hair.

## New Kind Spectacles for High-Grade Myopia.

THOSE of the readers of THE CIRCULAR who are also engaged in the manufacture and sale of optical goods will be interested in the following perhaps important invention of Dr. Franz Heilborn, oculist of Breslau, Germany. The inventor says in the *Central Zeitung für Optik und Mechanik*:

The physician who is requested by a high grade myopic person to furnish him with a suitable pair of spectacles will find himself in a certain quandary. The strong concave lenses, even if a full or very high clearness of vision is attained by their use, are open to the objections that they diminish the size of objects, disarrange the projection, disfigure the objects, and are too heavy. Many extremely short sighted persons therefore refuse strong concave lenses, because they cannot stand them. Beside this, adepts have also pointed

nearly two years been used by high grade myopic persons. They consist of a combination of a feeble concave lens of 5 or 6 D., and a German silver disc, which in most cases is placed behind the lens, and which is perforated in an entirely peculiar manner. These spectacles are to be used especially as working spectacles. The myopia, under debate here, moves within the limits of at least 10 D to 20 D., and beyond ( $4, 3\frac{2}{3}, 3\frac{1}{3}, 3, 2\frac{5}{6}, 2\frac{2}{3}, 2\frac{1}{3}, 2, 2, 2$ , etc., according to the old scale).

The holes in the disc are arranged in concentric circles, and the sharpness of vision produced by their use is the highest in comparison with the results of the stenopæic apparatus, including even the perforated spectacles constructed by Dr. A. Roth. The radical arrangement of the holes in the disc produces a new technical effect, which may be stated in the following three points:

According to Snellen's law of refraction, the rays falling from a center equally far upon a

—provided the eye were to remain immovably fixed behind it. But the eye is constantly in motion, so that the line of vision falls very easily beside the hole in the disc. There must consequently be also other holes, laterally from the central hole, to permit the eye to look through. The motions of the eye occur in circles around a point of revolution—that is, the mathematical line of sight, in its individual motions, describes radii of a circle starting from the place of rest, the center of which is the point fixed by the place of rest. When, now, the holes in the disc are likewise placed in radii, the point of intersection of which is a central hole, then by the lateral motion, the eye will readily find a corresponding hole.

It will also be seen from the smallness of the above mentioned optic angle that the distance of the holes one from the other (found empirically) is entirely definite. They must stand sufficiently far apart that the fields of view seen through them (which in consequence of the diffraction of the light on the periphery of the holes, are naturally larger than they should be according to the magnitude of the optic angle) just touch one another. If the holes stand too far apart, the field of view is interrupted; if too close, the eye will endeavor to look through two holes at the same time, and the fields of view cover one the other, thereby giving rise to disagreeable diffraction circles.

As third reason for the peculiar operation of the radial disposition of the holes in the disc may be regarded the circumstance that principally the concentric circles nearest to the center become active in seeing, while those more toward the periphery serve for illuminating the field of view. The concentric arrangement is best suited to the shape of the pupil, which is equally round. Again, it is well to have as many holes as possible, even though within a certain limit, and this is effected in the readiest way by dividing the holes upon the periphery of circles, because these holes will occupy the relatively smallest space. Not only is the distance of the holes in the discs found empirically, but also their size and number are the results of several years' experiments.

As will be seen from the illustration, the discs are to be hinged behind the lenses, and are kept in place by a small hook on the nose-piece. As regards the practical experiences with the use of the radial spectacles, they are as follows: An examination was always conducted in such a way that the high grade myopic persons were first tried with concave or cylindrical lenses or combinations of them; next with spectacles with a single stenopæic hole or in combination with single concave or cylindrical lenses; third, with Roth's perforated spectacles alone or in the combination mentioned just now; fourth, with the radial spectacles alone or in the combination mentioned just now. In nearly every instance in the test with the last, there was an increased sharpness of sight, as compared to the other three. From numerous experiments, the following is quoted:

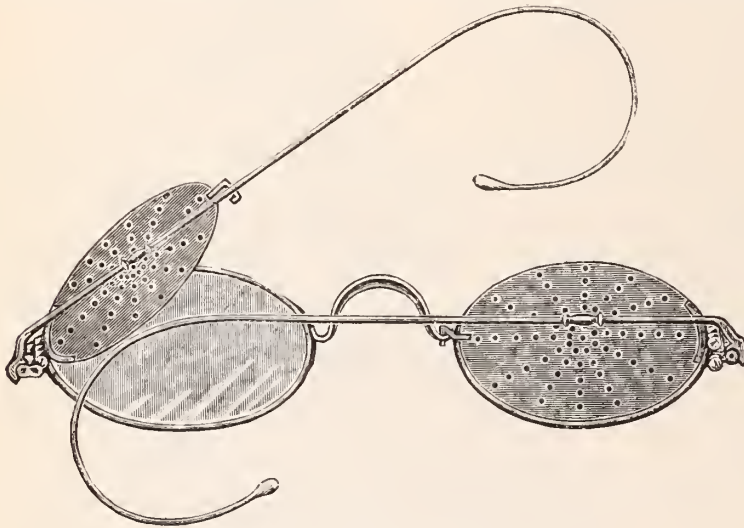

SPECTACLES FOR HIGH GRADE MYOPIA.

out that these strong lenses are directly injurious. Prof. Hermann Cohn, whose inquiries into the subject of myopia are most eminent, says in his excellent *Text Book on the Hygiene of the Eye*, "I have seen lately that by the wearing of such strong spectacles the myopia increased even in the thirties of age." For this reason, many oculists therefore recommend concave lenses up to 6 D. only; others go as high as 8 D.

Such relatively weak lenses, however, are of an illusory value only for the extreme degrees of myopia, as they compel the patient to work at too close a distance; it is the predominant opinion of the greater number of oculists that "the origin and increase of myopia is due to the exertion of the muscle of accommodation, or to the interior straight muscles of the eye for producing the necessary convergence for seeing close by, or to the effect of the trochlear." It would therefore be a great relief to extremely short sighted persons to wear a pair of spectacles which, although they contain feeble lenses, permit them to work at a proper distance,

From these premises emanated the spectacles described in the following; which have for

spherical surface (cornea), are refracted uniformly, and therefore unite in one point. Consequently, those rays which pass through the holes lying upon the periphery of concentric circles will intersect at one point, and the points of intersection of all these luminous pencils will, considering the closeness of the concentric circles, lie close one to the other, in the so-called focus. By the accommodation of the eye, a sharply defined picture is produced upon the retina, while all those rays passing through holes not lying upon the peripheries of concentric circles are refracted unequally, will not intersect in one point, and are subject therefore to more or less divergence.

A second point of the special action of the radical arrangement of the holes is as follows:

The angle limiting the central field of view is very small (not even one-half of a degree). Our test lenses for determining the central sharpness of vision embrace an angle of 5 minutes in the corresponding normal distance; for this reason, when perforated spectacles are used, which are situated closely before the eye, this will look through only one hole, and, indeed, a single hole would suffice

Mrs. R. B., 35 years, R. E.—11.0 D S. = 6-6;  
L. E.—10.0 D S. = 6-8;  
reads without glasses S. > 6-60;  
with stenopæic hole S. > 6-60;  
with Roth's spectacles S. = 6-60 — 6-40 barely;  
with radial spectacles S. = 6-20 — 6-18 barely;  
with Roth's spectacles and combination of ... 7.0  
D; S = 6-6 (with the right eye);  
with radial spectacles and combination of ... 4.0 D;  
S = 6-6.

High grade myopic persons soon accustom themselves to these working spectacles, and are little disturbed by the small obscurity. At any rate, a good illumination is necessary for the use of these spectacles. While less short-sighted persons are improved by using them as working spectacles, because they can either with very feeble concave lenses or without them keep their work at a proper distance, and yet refuse to wear the radial spectacles, as the dark circles occurring in the field of view annoys them, this objection is not raised in many cases by persons of a high grade of myopia, and—good illumination always supposed—they state the field of view to be free. The first test with the radial spectacles is best made with direct entering sunlight.

Doctors should employ the radial spectacles in the above indicated manner as test for the different grades of myopia, especially for the higher grades, and it furnishes them many interesting results for judging of the higher grades. These test spectacles consist of a simple frame with two discs perforated in above stated manner. The concave lenses may be placed both in front and behind the discs.

As previously stated, it is well to first try the person with concave lenses, and next with the test spectacles, placing different lenses before the discs, until the highest degree of sharpness of vision is obtained. It has occurred already that isolated cases of high grade myopia were not influenced by these experiments. If, for instance, a patient has —12, full sharpness of sight is in many cases produced with disc and—6, or 7 D. If this short-sightedness could not be influenced by the radial spectacles, it would be equivalent to saying that the patient has attained with —11.0 D. or 10.0 D. the highest attainable sharpness of sight (because from 1 to 2 D. difference may be supposed as caused by the divergence of the periphery rays). These latter cases in which the highest sharpness of sight was not produced by the radial spectacles with weaker lenses, show in a remarkable manner a bad condition of the sharpness of sight. It is questionable whether these cases can be called simple cases of myopia, while on the other hand the larger number of cases of myopia in which the highest sharpness of sight, produced with discs, and relatively much feebler concave lenses, might be called a combination of myopia and astigmatismus irregularis. Many circumstances are in favor of this astigmatismus irregularis, which might then be considered as a constant companion of high grade myopia, and explained by the length growth of the bulbus.

It is at any rate of interest to the examining physician to be able to definitely state in every case of high grade myopia whether it

would generally be possible by the above explained method of examination to diminish each time the high-grade myopia, and by how many dioptries.

In many forms of complicated astigmatism also the radial spectacles without concave lenses might be employed where cylindrical lenses would either fail of effect or could not be borne.

### Ivory Production.

AN exchange states: "The future of the ivory industry is giving a good deal of concern to those who are specially interested in it. The total consumption of ivory amounted, on an average, between the years 1879 and 1883, to 1,843,600 pounds. In the four years between 1889 and 1893 this average had fallen to 1,423,400 pounds. A reduced import and consequent rise of prices for the raw ivory caused the increased use of cheaper materials in substitution for ivory. For instance, in the first named period there were used for knife handles, combs and 'various articles,' respectively, 490,600 pounds, 409,200 pounds and 149,600 pounds, while in the latter period the figures of consumption under these three heads were 189,400 pounds, 200,000 pounds and 74,800 pounds. But there are two purposes for which no effective substitute for ivory has yet been found, viz., the mounting of piano keys and the making of billiard balls. In the first period these were credited respectively with a consumption of 354,200 pounds and 127,600 pounds, and in the latter four years with an average of 356,400 pounds and 107,800. The size of billiard balls varies in different countries. In most of the northern countries small balls are used; in moderately warm climates medium sizes are preferred, while in tropical countries the taste of the billiard players runs to the largest sizes.

"America and France absorb half the annual supply of balls, the remainder being taken by England, Germany and the other countries. In bad financial years the consumption of balls will run down from 110,000 or 115,000 to 80,000 or 85,000. As those elephants' teeth which are the best suited for billiard balls are getting scarcer and scarcer, great difficulty is experienced in meeting the present demand, and prices are rapidly advancing, being at present more than \$4 per pound for good quality. The best teeth are those of full grown female elephants of the higher regions of Equatorial Africa. These teeth usually weigh from 12 to 18 pounds each, but are never heavier than 30 pounds. Bull elephant teeth are often flat and diseased in the center. America, Russia, England and Italy buy the best billiard balls, while France and Germany, for the sake of

cheapness take many inferior balls, such as are obtained from the points of other teeth, and from hard West African teeth. Under the microscope, ivory is seen to consist of millions of infinitely small cells or tubes, filled with a glue-like substance. To this construction, calling to mind that of honeycomb, ivory owes the wonderful elasticity which, in combination with other qualities, is not possessed by any other substance. For perfect billiard balls the grain and weight of the different parts of the ivory would be uniform, so as to give equal balance and rolling. This accounts for the high prices that are asked for the choicest kind of billiard ball ivory.

"It is believed by experts that in twenty or thirty years a really fine ivory ball will be a rare article, and that with the disappearance of ivory the game of billiards will lose much of its interest. Another use of ivory for which no substitute gives satisfaction, is the covering of piano keys. All good players say there is no substance that can equal ivory in smoothness and delicacy of touch. The speed of execution of the modern virtuoso, often involving several thousand finger contacts in a few minutes, is such that the more minute fraction of an increase in the 'drag' of the keys would be fatal to the success of a performance. This augmentation of 'drag' is the inevitable accompaniment of all substitutes heretofore tried. It is not surprising, therefore, that the sale of ivory keys has always shown a steady increase, and this branch of the ivory trade is the one that is likely to last the longest time."

**Soldering Glass.**—Recent investigations by Margot have established that an alloy, composed of 95 parts of tin, and 5 of zinc, melts at 200° C., becomes firmly adherent to glass, and is unalterable, and exhibits an attractive metallic luster. An alloy, consisting of 90 parts tin, and 10 of aluminium melts at 390° C., becomes strongly soldered to glass, and is possessed of a very stable brilliancy. With these two alloys it is possible, it is claimed, to solder glass as easily as it is to solder two pieces of metal, and this operation may be done by the soldering of two pieces of glass, when heated in a furnace, by rubbing their surface with a rod of the solder, the alloy, as it flows, being evenly distributed with a tampon of paper or a strip of aluminium, or an ordinary soldering iron can be used for melting the solder.

#### AN EVIDENCE.

Trivet—Miss Tenspot takes a great interest in politics.

Dicer—Does she?

Trivet—She has had her new shirt waist trimmed with campaign buttons.—*Judge.*



The STATIONERS' ENGRAVING CO.,

98 TO 102 NASSAU STREET, NEW YORK.

MAKERS OF

WEDDING INVITATIONS, RECEPTION AND VISITING CARDS

of the Best Quality, which are offered to Jewelers of recognized standing only.

Trade Mark 'SILVER WHITE,' registered.

# OPPENHEIMER BROS. & VEITH,

## CUTTERS OF DIAMONDS,

## DEALERS IN WATCHES,

65 NASSAU STREET (PRESCOTT BUILDING), NEW YORK

These well-known Razors, the quality of which is warranted, possess this great advantage, that they may be used for ten years before they require actual sharpening. Before using them, it is necessary to rub them on good leather strop. Lecoultre's Strops (to be had with the Razors), should be used in preference to others.



THIS CUT IS TWO-THIRDS OF REGULAR SIZE.

# MATHEY BROS., MATHEZ & CO.,

SEND FOR PRICE LIST

SOLE AGENTS. 21 & 23 Maiden Lane, N. Y.

## SLOAN & COMPANY,

SUCCEEDING

JOHN A. RILEY & SLOAN CO.,

MANUFACTURING JEWELERS,

23 MAIDEN LANE, N. Y.

HAYS BUILDING.

AUGUSTUS K. SLOAN, Pres.  
FRANK T. SLOAN, Vice-Pres.

BENNET OSBORN, JR., Treas.  
ALLAN A. McDONALD, Sec'y.

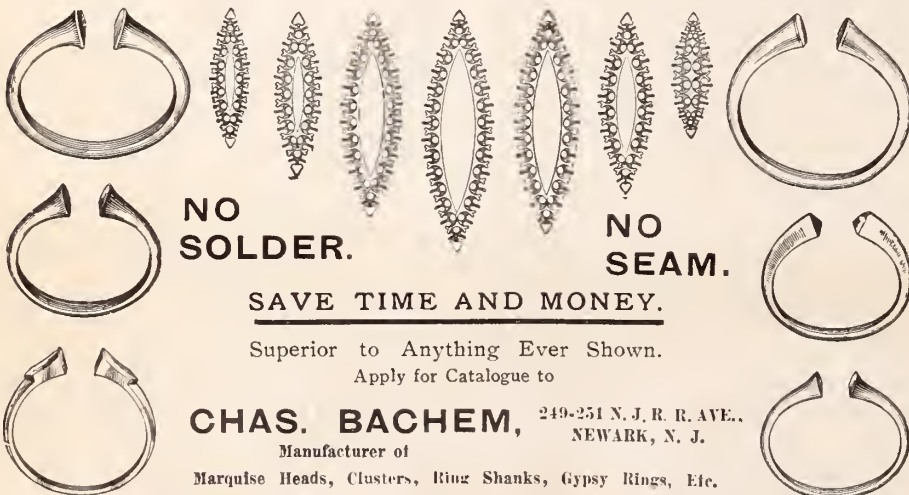

NO  
SOLDER.

NO  
SEAM.

SAVE TIME AND MONEY.

Superior to Anything Ever Shown.  
Apply for Catalogue to

**CHAS. BACHEM,** 249-251 N. J. R. AVE.,  
NEWARK, N. J.

Manufacturer of  
Marquise Heads, Clusters, Ring Shanks, Gypsy Rings, Etc.



FOR RELIABLE OPTICAL & WORK  
SEND TO  
JOS. FRIEDLANDER & BRO.,  
OPTICAL LENS GRINDERS,  
9 MAIDEN LANE, - - NEW YORK.  
SEND FOR DESCRIPTIVE CIRCULAR OF OUR FRAME AND LENS CABINET.

## CUT GLASS FOR SILVERSMITHS.



STANDARD CUT GLASS CO.,  
545 to 549 West 22nd Street,  
NEW YORK.

## JACOT & SON,

Importers and Manufacturers of

## Musical Boxes,

39 Union Square, New York.

## A. J. COMRIE,

AUCTIONEER,

22 John St., N. Y.

SPECIAL SALESMAN OF WATCHES, DIAMONDS.  
BRIC-A-BRAC, FOR ESTABLISHED JEWELERS.

WRITE FOR PARTICULARS.

## ENAMELERS

OF GOLD, SILVER AND PLATED JEWELRY,  
Enameled, Plain and in Colors

ALSO OF  
SOCIETY EMBLEMS,  
YACHT AND COLLEGE FLAGS.

All Varieties of Painted Enamel Work.

## S. S. WILD & SON,

179 Eddy Street, PROVIDENCE, R. I.

Correspondence Solicited.  
Telephone Connection.



WE HAVE  
ON HAND

A Large Number of Small

## Advertising Cuts

Specially Designed for JEWELERS'  
ADVERTISING, such as above, at

75 Cents per Electrotpe.



SEND FOR PROOF SHEET.



THE JEWELERS' CIRCULAR PUB. CO.,  
189 Broadway, New York.



## The Rambler's Notes.

WHAT THE RAMBLER SAW AND HEARD AMONG THE DEALERS IN ART POTTERY, CUT GLASS, BRONZES, ETC.

### NEW HOLBEIN WARE.

**P**ROMINENT in the magnificent display of English pottery made by Bawo & Dotter, 26-32 Barclay St., New York, is a most complete line of Holbein ware, the latest product of the Doulton kilns. Though introduced some months ago, the line is now shown extensively for the first time by Bawo & Dotter in vases, trays, candlesticks, jugs, etc., of various sizes. The deep, dark rich colors, olive green, ochre-brown and yellow, in the quaint decorations consisting principally of heads and flowers in relief, make this line one of the most desirable the jeweler can find among new English wares.

### NEW BRONZE FINISHES.

**T**WO new and richly beautiful finishes which, with the Baleric mentioned a few weeks ago, are now attracting the attention of the trade to the lamp department of Bradley & Hubbard Mfg. Co.'s salesrooms, 26 and 28 Park Place, New York, are called Dresden gold and Etruscan gold. The former consists of matt gold panels with beaded edge in Colonial style, upon a background of bright gold, while the Etruscan is a dead, almost cream, gold finish whose rich effect must be seen to be appreciated. Both are shown in a full line of banquet lamps in connection with onyx and metal in other finishes.

### HAVILAND & CO.

**A** NEW special partnership under the New York laws has been formed by the members of Haviland & Co., importers and manufacturers of fine French china and porcelain, Limoges, France, and New York. Charles Edward Haviland and George Haviland, of Limoges, France, are the general partners; and Mary Conklin Miller Haviland, Jeanne Haviland Camu and Albert Haviland, of Limoges, and Gustave Boutelleau and Georges Boutelleau, of Barbezieux, France, are the special partners. Mary Conklin Miller Haviland has contributed the sum of twenty-five thousand dollars, Jeanne Haviland Camu, eight thousand dollars, Albert Haviland, twenty-five thousand dollars; Gustave Boutelleau, three thousand

dollars, and George Boutelleau, three thousand dollars, as capital to the common stock. The period at which the said partnership is to terminate is the 31st day of December, 1933.

### NEW PRODUCTIONS IN CROWN PAIRPOINT.

**S**OME of the most artistically perfect decorations to be produced in the Crown Pairpoint ware of the Pairpoint Mfg. Co. may be seen on some new vases and jars recently added to the company's New York salesrooms, 46 Murray St. The paintings are large figure panels showing Eastern groups or Oriental dancing girls. A very beautiful specimen of the company's Crown Milano ware is a large lamp just received, containing on the body and decorated globe, immense hand painted portraits of Mozart and Beethoven.

### INVOICE OF MARBLE STATUARY.

**M**ARBLE statuary is now carried for the first time by Lazarus, Rosenfeld & Lehmann, 60 Murray St., New York. The first line to be received by this firm has just been opened and contains large and small busts, figures and groups. The pieces are all of Carrara marble and appear in some of the standard as well as many of the latest popular subjects.

THE RAMBLER.

## Useful and Ornamental China.

**W**ONDERFUL in extent and beauty is the importation of china and pottery this season, says a writer in *The Ceramic Monthly*. Never has one had greater opportunity to revel in things beautiful than amid the plaques, jars, vases, afternoon tea sets, and other innumerable articles, useful, ornamental, and artistic, shown in the shops at this time. The blue and white Delft ware is particularly handsome in plaques. Two of these of very large size, with reproductions of Rembrandt's paintings, representing respectively himself and a burgher of his time, are most wonderful in finish. It may be here noted that owing to its porous composition, Delft is not found in tea pots, tea cups, or such pieces of useful nature. The vases and jars are very beautiful in design, and are peculiar in their small range of variety of shapes,

closely following the antique models seen so plentifully in Hollandisch houses. Beautiful specimens of Haviland and Doulton are being shown. An empire set of Haviland in tea plates with two large bread plates, paintings of Josephine and her court ladies on the twelve small plates, and Napoleon on the bread plates is taken from Sèvres designs.

In the Doulton china is shown a wonderful set of game plates. They are painted by Wilson: each one shows a different species of game bird. The border is a deep creamy tint with pearl enamel decoration. A vase of Doulton is exquisitely decorated in raised white enamel work on blue ground. A compotier in the elaborate rococo style of decoration is another example of Doulton. Two beautiful specimens of Coalport are, first, a set of three pieces—coffee pot, cream jug and sugar bowl of pretty design—decorated in fine enameling, which is so thin in composition that it has the appearance of a perfectly flat surface. The second piece is a tea caddy of white ground and dull gold decoration.

Royal Viennese or Austrian china is wonderful in richness of color and fineness of decoration. A covered coffee cup on feet in black and gold effects has a painted medallion of fine workmanship. A large round plaque has a well executed reproduction of the modern painting, "The Three Fates;" the border work is also very fine and elaborate. An unusual specimen of royal Meissen, more familiarly known as Dresden china, is a deep set tray of small proportions and black background, over which is a scroll pattern in mosaic effects—blue, dull pink and white effects connected by brown tracery. Most wonderful specimens of Majolica ware have been imported, the most novel is the Brittany pottery, exact in the reproduction of antique shapes, and decorated with the costumes of the olden days. Each piece has somewhere on it the arms of Brittany. A pitcher of flat shape and open neck is decorated with a boy piper of quaint device. A flat tray has a market scene, a group of peasants weighing and over-seeing the weighing of some commodity of food. A beautiful specimen of Conte-galli is a round jardiniere decorated in the gay colorings for which this ware is noted. A clock with stand is of the same ware, also a picture frame of butterfly design with spread wings, in which is the open space for the photograph.

DEPARTMENT OF  
ADVICE AND CRITICISM  
ON  
RETAIL JEWELERS' ADVERTISING.

[This department is free to every retail jeweler and optician. Forward for criticism your newspaper ads., booklets, catalogues, novelties, circulars, etc. Ask advice and offer suggestions. Replies in these columns are unbiased. Make letters as full and particular as desirable. Every letter and ad. sent will receive full attention, though the publication of the matter may sometimes be delayed a week or two. Address all letters and other matters to The Jewelers' Circular Pub. Co., 189 Broadway, New York.]

PART XX.

IN the matter of newspaper advertising to the general public, the jewelers of London are ahead of their contemporaries in New York and other American cities. The jeweler of London is a merchant first; he is a dealer in merchandise, and he moves his stock as merchandise. In his advertise-

ment, he keeps ever before his mind that these are goods, many of them being as necessary articles of apparel as the hat and shoe or of utility as the chair and table.

Advertising he does not consider a luxury or a manifestation of dilettantism; but an industrial force, an important wheel in the

more potent agency than any other; for a man may be able to do business without clerks, salesmen, counters, show cases, incandescent lights, carpets, rugs, gold paint, Lincrusta-Walton; but he cannot do business if he does not in some manner let people know that he is in business, that he has

seem to begrudge himself any space in the journals he selects to advertise in, but he utilizes every modicum of space he engages. The ad. reproduced herewith from the London *Queen* (June 10) occupied 1/2 page in that large and voluminous journal, the page size being 15 1/2 x 10 inches. In this same issue, the writer notes that Mappin & Webb occupy an entire page for illustrations, descriptions and prices of sterling silver and "Prince's plate," and 1/2 page for fitted traveling bags; J. C. Vickery 1/2 page for jewelry, bicycle cases and novelties, illustrated, described and price marked; the Goldsmith's and Silversmith's Company 1/2 page for silver goods, 1/2 page for dia-

Goods Sold at Wholesale Prices, Designs are Exact Size, & all Goods sent Free & Safe by Post. Illustrated Catalogue (3000 Illustrations) of Novelties in Jewellery, Silver, & Electro-Plate Post-Free.

SPECIAL.—The Association of Diamond Merchants, 6, Grand Hotel Buildings, Trafalgar Square, W.C., give highest prices for Precious Stones, Second-hand Jewellery, and Old Gold, having customers who prefer Second-hand Articles. This has been a successful department with the Association many years. Anything sent to them receives attention by return of post.

1896

New Signal Scarf Pin, best Gold, beautifully enamelled in colours, £1. 5s. Let us keep together for and Gold mutual protection. Scarf Pin Any signals made to real Pearl order, as Scarf Pins, Ball, 12/6 Brooches or enamelled in Matchboxes.

18-ct. Golf Ring, real Pearl Ball, £1. 7s. 6d. 15-ct. lighter, 17s. 6d.

Handsome Diamond Pendant, contains 50 Brilliants, no Roses; forms also Brooch or Hairpin. Stones set transparent, £17. 15s. A Round Pendant, same pattern same price. Bracelet Band for same, £3. 15s.

Three Row Diamond New Moon Brooch, £10 10s

New Pattern Bracelet, 2 Brilliants and 1 Ruby or Sapphire Centre, £5. 15s.

Gold Safety Pin Brooches, this one 3s. 6d.; larger, 4s. 6d.; 5s. 6d.; 7s. 6d.

Same in Silver, 1s. 1s. 3d., 1s. 6d. each. Smaller size in Gold, 2s. 6d.

New Tie Brooch, containing 4 Diamonds, £5. 5s.

New Diamond Star Brooch, Pendant, or Hair Ornament. 25. Choice whole Pearl Head Necklace for above, £5. 5s.

A variety of larger Stars in Stock.

Best Gold Brooch, Diamond Head, £1. 15s. with Ruby or Sapphire, £1. 7s. 6d.; Pearl, £1. 5s.

Solid Gold, Ruby Eyes. 12s. Lighter makes, from 9s. 6d.

Best Gold Scarf Pin. Smaller size, 5s.

New Diamond Brooch, containing 23 Diamonds and 1 whole Pearl, £4. 4s. Bracelet to match, £5. 5s. A Brooch in 2nd quality Diamonds, without Pearl, £2. 17s. 6d.

Set with 4 Brilliants and 1 whole Pearl, 75s.

Brilliant half-Hoop Ring, 18-ct. Gold Mounts, £33. 15s.

Diamond Partridge Scarf Pin, £3. 3s. All Gold, £1. 15s.

New Match Stand, Sterling Silver Mount, 7s. 6d. Any Flag to order. Grouse, Wild Duck, Snipe, Woodcock, and Pheasant Scarf Pins same prices.

New Pattern Ruby & Sapphire Pearl ends.

Diamond Brooch, centre, whole £4. 4s.

18-carat Gold Ring, £1. 15s. 15-carat, lighter make, £1. 1s.

Diamond Gamecock Scarf Pin, £4. 4s.; small size, £3. 3s. All Gold, £1. 15s.

New Pattern Brooch, 3 Rubies or Sapphires, 2 whole Pearls, 9 Brilliants, and 15s. 6d.

New Moon Brooch, 7 Brilliants and 8 Rose Diamonds, £5. All Rose Diamonds, £4.

Best Gold, Pearl Brooch, 17s. 6d.

New Moonstone Interchangeable Brooch, and Diamond Baggie and £3. 3s.

New Scarf Pin, Stones set transparent in Ruby and Diamonds, 30s. Diamonds and Sapphires or Turquoise same price.

Our Special Ordained Silver Brooch, complete, with Ordained Steel Keyless Watch, warranted, £2. 2s. New letter monogram, keyless monogram, £3. 3s.; or monogram, £3. 3s.; or with any two-letter monogram, £4. 4s. Dressed monogram with Diamond, £5. 5s. Smaller Watch & Brooch in Gold, £2. 1s. Ordained Ribbon Bow Brooch, complete in case, £1. 1s.; or with Silver Initial set with Diamond, £2. 2s.

Best Old Brooch, Flags enamelled in correct colours. Come Alongside, £2. 2s.

THE ASSOCIATION OF DIAMOND MERCHANTS, JEWELLERS, & SILVERSMITHS, 6, GRAND HOTEL BUILDINGS, TRAFALGAR SQ., LONDON, W.C. Diamond Cutting Factory: AMSTERDAM. Telegrams: "Ruspoli, London."

ments he makes it clear to the public that he has goods to sell; that he is in business to sell goods and that his store is stocked with goods. He tries to move his stock, as the draper, the hatter, the shoer, and other dealers in merchandise move theirs. While remembering that jewelry and silverware are products of indus-

trading machinery of commerce. The cost of advertising is considered to be as necessary a part of the expenses as the cost of clerks, salesmen, show cases, counters, chairs, incandescent lights. All these are agencies for the bringing and retaining of trade; so is advertising. And if we look deeper into the subject, we will find that advertising is a

method he adopts to thus inform the public is advertising. These facts the London jeweler seems to feel. The average American jeweler, undoubtedly, feels them also, but there are many who look upon advertising as a savable expense and a trial to the nerves. The London jeweler doesn't

mond jewelry, 1-6 page for a new flexible curb chain bracelet; Streeter & Co. 1/2 page for gem mountings; Mappin Bros., 1/2 page for dressing bags and toilet accessories and 1 page for silver goods; Thornhill 1/2 page for miscellaneous articles; Benson, 1/2 page diamond jewelry, and 1-8 page for watches; Wilson & Gill 1/2 page silver toilet

articles, etc. All these ads., filling eight large pages, showed goods of timely interest, fully described and attractively priced. This is not an unusual volume of business, for it is seen weekly, not only in the *Queen*, but in the *Lady's Pictorial*, the *Illustrated London News*, the *Graphic* and other large weekly papers. All the ads. are filled with interesting information, and contain such a large quantity of articles that many dimly formed demands in present making must be satisfied. In the ad. here shown are illustrated 45 articles, with descriptions and prices. Not a modicum of space is wasted, and even a casual glance at the ad. must convince one that the stock of the firm must be broad, comprehensive and extensive. Compare the *Queen's* display of jewelry ads. with that of its American contemporary, *Harper's Bazar*. On looking over a copy of the issue of this journal for July 5 we find no jewelers' ads. whatever. However, if there were any jewelers' ads., they would be rather specimens of finical typesetting than commercial announcements. They would occupy a few inches of space each, and would likely be void of busi-

ness bringing attributes. Isn't it possible for a jeweler to select a quantity of timely and seasonable articles and push their sale by proper advertising? These are dog days, but the world does not stand still.

\* \* \*

Charles Austin Bates, the advertising expert, writes in *Printer's Ink*, the following regarding the advertising of Ambrose Kent & Sons, Toronto, Ont.:

"Most of the ads. sent are really first rate. There is, in almost all of them, a too evident straining after display, and this often defeats its own ends, by giving the ad. a spotty, mixed-up appearance. The simplest, good, readable type, with a strong head-line, and perhaps a border, is about the best that can be done in the way of display. The addition of an illustration to an advertisement of this sort displays it perfectly if the illustration is good. Fanciful arrangement of types and borders is more likely to hurt an advertisement than to help it.

"An advertisement is meant to be read, and the easier and simpler you can make the operation the better will be the results. Chop-

ping the ad. up into disjointed parts merely serves to make it more difficult to read—serves to lessen the number of its readers. Most of these Kent ads. have the positive merit of quoting definite prices. I reproduce some of these because they may be useful to other jewelers.

**KENT'S Richmond Street.  
THE WHEELS O TIME**

Dinner Spoiled—Husband mad—Servant girl ugly—The Ancient Clock did its best—it's old enough to rest—its going qualities have gone—you want a Good Clock and temper saver—an intelligent clock that won't mislead you—we have them for THREE DOLLARS—you save time and worry by purchasing one. We sell all kinds at all prices—and every clock fits the price.

—Residents of the city when entertaining friends from the country are cordially invited to visit our showrooms, which are now recognized as one of the chief attractions of the city.

**AMBROSE KENT & SONS,  
Watchmakers and Jewelers,  
5 and 7 Richmond St. West,  
TORONTO.**

CANADA'S GREATEST JEWELRY STORE.

**If Your Boy**

is not on time, the chances are it is no fault of his. HAS HE A WATCH? If not, then you are to blame for his being behind time. He might have a first-class timepiece as low as ONE SEVENTY-FIVE

UP TO SIX, according to style and quality; all the style anybody could ask. Good enough for you, too, if you need a watch.

**AMBROSE KENT & SONS,  
156 Yonge St.,  
5 and 7 Richmond St. West, TORONTO.**

CANADA'S GREATEST JEWELRY STORE.

**Your Wife's Watch**

ought to be a good one. Her minutes are valuable—you see that at meal time. Have you not learned her requirements?

**She Needs a Watch**

that she can risk anywhere—accurate, stylish and genuine, moderate in price. Our special movements cased in 14-kt gold cases, handsome as a fifty-dollar watch, though it costs only thirty down to

**TWENTY DOLLARS.**  
Mail orders filled promptly.  
**AMBROSE KENT & SONS,  
156 Yonge St.,  
5 and 7 Richmond St. West,  
TORONTO.**

CANADA'S GREATEST JEWELRY STORE.

**Parents . . .**

give your boys good watches and they'll treasure them as a Vanderbilt would a million dollars. We have Boy's Watches silver case, Waltham movement—a most excellent timepiece. We warrant them

**SIX DOLLARS.**  
"Buy Only the Best!"  
Order by mail from  
**AMBROSE KENT & SONS,  
156 Yonge St.,  
5 and 7 Richmond St. West,  
TORONTO.**

CANADA'S GREATEST JEWELRY STORE.

**KEEP AN EYE  
ON YOUR EYES.**

Do not postpone the use of glasses a moment if you feel the need of them.

Remember the longer your eyes are deprived of the aid they need the worse they become—consult OUR DOCTOR OF REFRACTION. He will subject you to a careful examination of your eyes—turnish at moderate cost spectacles or eye-glasses in steel, nickel or gold, with best quality lenses.

**AMBROSE KENT & SONS,  
156 Yonge St.,  
5 and 7 Richmond St. West, TORONTO.**

**O. NEWMAN,**  
Gold and Silver Electro-Plater.  
Etruscan Coloring a Specialty.  
WATCH CASE POLISHING.  
75 Nassau St., Room 8 Rear Building, New York.

**H. M. RICH & CO.,**  
Jewelry - Auctioneers,  
21 School Street,  
BOSTON, MASS.

**QUICK SELLERS.....**  
IN STERLING SILVER  
ARE MADE BY  
**CODDING BROS. & HEILBORN,**  
North Attleboro, Mass.

**A** **AMERICAN** ESTABLISHED 1872.  
INCORPORATED 1894.  
**WATCH TOOL CO.**

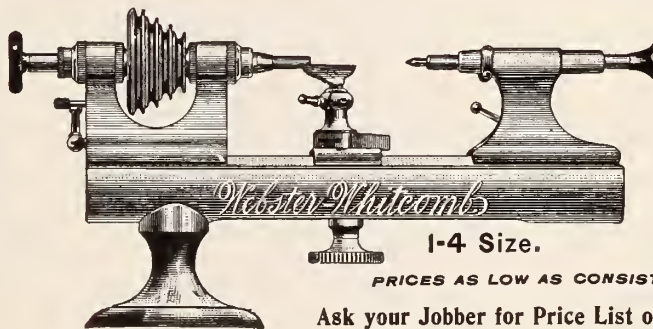

THE  
**Webster-Whitcomb**

GROWS IN POPULARITY

PRICES AS LOW AS CONSISTENT WITH QUALITY.

Ask your Jobber for Price List of 1895, or write to us at

**Stoney-Batter Works, Chymistry Dist., Waltham, Mass.**

**AIKIN, LAMBERT & CO.,**  
MANUFACTURERS OF  
FINE GOLD PENS, HOLDERS, PENCILS,  
TOOTH PICKS, and NOVELTIES.

PAUL E. WIRT FOUNTAIN PENS, at new and lower prices . . .  
MERCANTILE FOUNTAIN PENS, guaranteed to give satisfaction.

Catalogues with terms and discounts furnished to the trade.

BRANCH, 103 STATE STREET, - - - CHICAGO.

**AIKIN-LAMBERT JEWELRY CO.,**  
IMPORTERS OF  
**DIAMONDS.**

JOBBERS IN

**WATCHES, JEWELRY, CHAINS  
NOVELTIES, ETC.**

LATEST DESIGNS.

LOWEST PRICES

**19 MAIDEN LANE, NEW YORK.**

CYCLING PROGRESS  
EXEMPLIFIED.

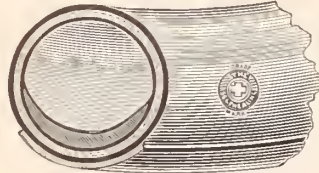

**THE WONDERFUL  
SELF-HEALING TIRES**

are single tube, finest rubber, finest wove Sea Island cotton fibre, re-enforced inside and outside on tread, and no better tire can possibly be made. They are fully guaranteed against all climatic changes, are the most resilient ever made, and when punctured instantly heal the wound of their own volition.

THEY WEIGH NO MORE THAN OTHERS,  
COST NO MORE,  
AND ARE WORTH TEN TIMES MORE.

SEND FOR TIRE BOOKLET.  
Wm. H. CAHN, GENERAL MANAGER,  
48 and 50 Maiden Lane, New York.

BY EVERY TEST THEY ARE THE BEST.  
THE UNIVERSAL FAVORITES.



SUPERB  
**Olympic**  
BICYCLES

For sale by more than 2,000 Jewelers, and constructed to meet the demand for finest quality. For Adults and Juveniles.

SEND FOR EXQUISITE CATALOGUE.

Top Grade "Olympics" have SELF-HEALING TIRES.

Olympic Cycle Mfg. Co.,  
N. Y. Office: 35 LIBERTY STREET

General Jobbing Ag'ts, S. F. MYERS & CO.,  
WHOLESALE JEWELERS, Myer's Building, New York.

**RECEIVER'S SALE!**

TRADE OPPORTUNITY.

Entire Stock of

CHAS. JACQUES CLOCK CO.,

22 Cortlandt St., New York,

...Must Be Closed Out...

Latest Paris Novelties,  
all New Importations  
of this Spring

Together with LARGE STOCK of

ELLIOT CHIME CLOCKS,

And a Fine Line of Other

HALL CLOCKS.

By order of

ALBERT C. WALL, Esq.,

Receiver.

**BAWO & DOTTER,**

26-32 BARCLAY ST.

NEW YORK.

P. O. Box 1872.



NO LARGER STOCK  
OF

**HALL  
CLOCKS**

IS SHOWN IN  
THIS CITY.

Large Stock  
OF  
MOVEMENTS.

NEW DESIGNS  
IN CASES.

**STERLING**

Sheet and Wire Supplied. All Sizes.

**J. SCHAWEL & CO.,**

Gold, Silver and Platinum Refiners,

29 JOHN STREET, NEW YORK.

**AMERICAN WATCH CASE CO.,**

11 JOHN STREET, NEW YORK.

Manufacturers of FINE SOLID GOLD CASES.



Sold DIRECT to  
the RETAIL TRADE only.

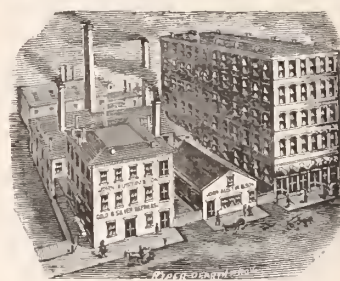

**34 YEARS OF  
HONEST RETURNS**

IS OUR GUARANTEE OF SATISFACTION  
TO ALL OUR CUSTOMERS.

WE DO OUR OWN SMELTING,

**JOHN AUSTIN & SON,**

ASSAYERS, REFINERS AND SMELTERS,  
74 & 76 Clifford St., Providence, R. I.



PRIZE  
MEDALS  
From  
EXCLUSIVE  
DESIGNS,

for out-door  
Sports.  
Club Pins  
of every  
description.

HENRY C. HASKELL.

11 John Street, New York.

Send for estimates.

**DUBOIS WATCH CASE CO.**



FINE HAND MADE  
SOLID GOLD CASES.

A PRIDE TO THE MAKER,  
DEALER & WEARER.

CAMPBELL-METCALF SILVER CO.,  
SILVERSMITHS,



ALL GOODS 925/1000 FINE.

Factory, Providence, R. I. Offices, New York and San Francisco.

**ROY PHOTO MINIATURES**

GIVE THE BEST RESULTS.

ROY WATCH CASE CO., 23 MAIDEN LANE, NEW YORK.

**DIAMONDS** Importers and Cutters. **L. & M. KAHN & CO.,** 172 Broadway, Cor. Maiden Lane, N. Y., **DIAMONDS**



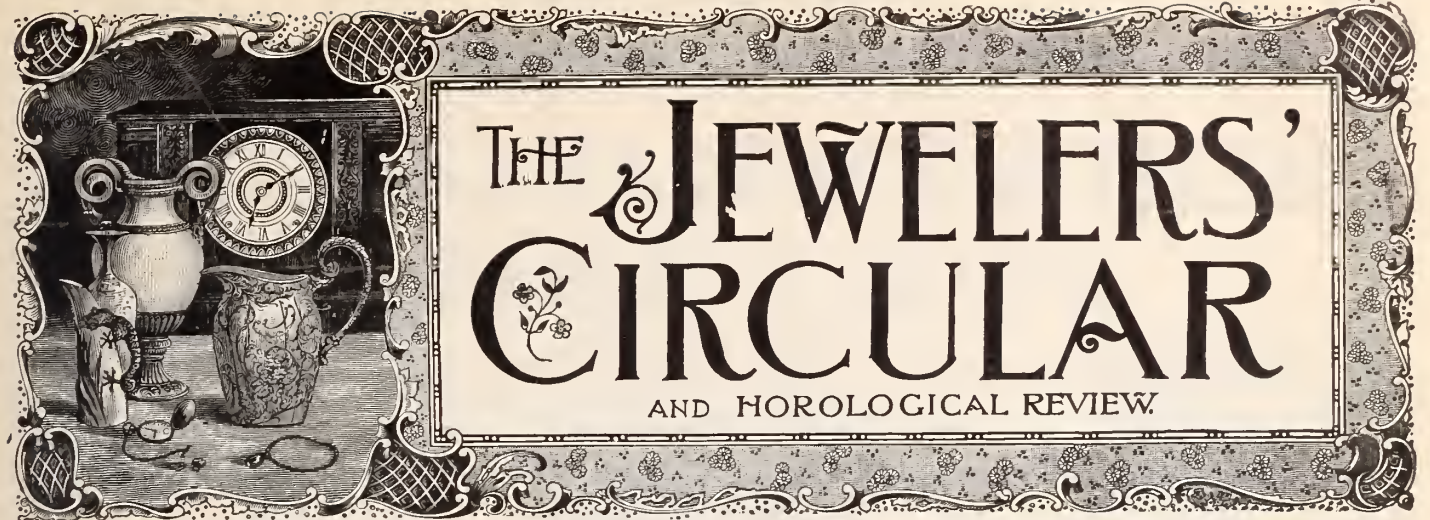

Copyright by THE JEWELERS' CIRCULAR PUB. Co.

189 Broadway, New York.

Entered at the Post Office in N. Y. as second-class matter

VOL. XXXII.

NEW YORK, WEDNESDAY, JULY 22, 1896.

No. 25.

## ART WORK FOR A BATTLESHIP.

THE battleship *Iowa* will soon be equipped with a magnificent service of silverware, designed and executed in the highest class of the modern silversmiths' art. The State of Iowa some time ago appropriated \$5,000 for such a service to be presented to the great battleship, which is now being completed at the Cramp shipbuilding yard in Philadelphia,

piece, one soup tureen, one soup ladle, one punch bowl, one platter for punch bowl, one fish dish, two fish carvers, one meat dish, two entree dishes, one salad bowl, two salad servers, two double vegetable dishes, two single vegetable dishes, two gravy boats, four compotiers, one water pitcher, one round salver, two black coffee pots, two sugar bowls, two

Capitol buildings and the battleship *Iowa*, and along the edges festoons of corn surrounding the seal of the State. A lower compartment of the centerpiece is for fruit. The meat platter will be an attractive piece. The edge will consist of festoons of the State flower, the wild rose, with bunches of corn, the chief product of Iowa, at each end, and on one end

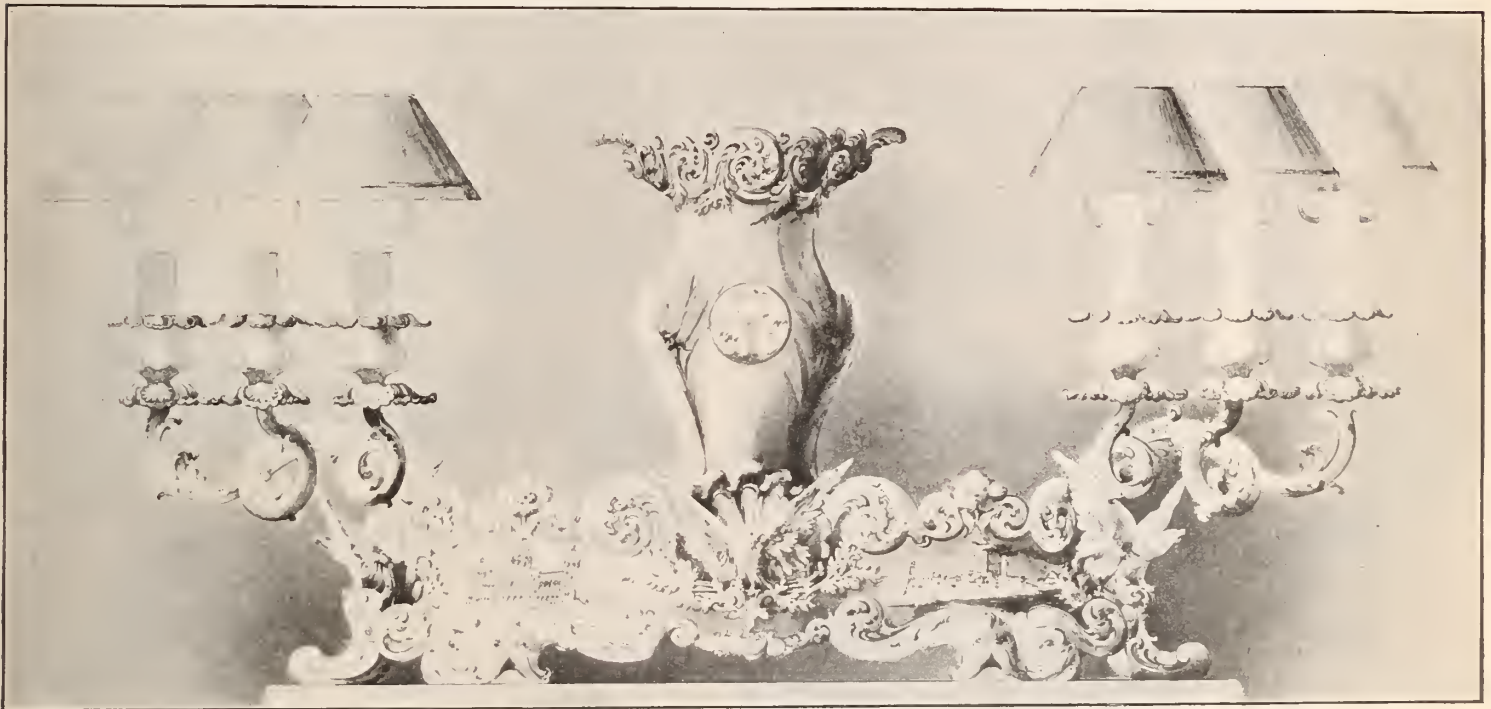

CENTERPIECE OF THE SILVER SERVICE FOR THE BATTLESHIP "IOWA."

Pa., as a recognition of the honor paid to the State by the selection of that name. But few sets of designs were submitted to the committee of State officials, the contract being awarded J. E. Caldwell & Co., Philadelphia, Pa. The centerpiece of the service is here depicted, being reproduced from a photograph of the original design. The set will consist of 40 pieces as follows: one center-

cream pitchers, two bread trays, two butter dishes and four olive or bonbon dishes. The centerpiece, as can be seen, will be an elaborate work. From the center will rise a vase for flowers, and from each end will project elaborate candelabra of five lights each. The body of the piece will be in raised work, and about it will be four large cast eagles. On either side will be designs of the Iowa State

will appear the seal of the State, and at the other that of the Navy Department. Throughout the whole service the designs will be conspicuously emblematic of the country and the State it represents, and its thorough appropriateness will be as evident as its great beauty. The 40 pieces will contain at least 1,970 ounces of sterling silver. J. F. Thomas, of J. E. Caldwell & Co., obtained the contract for the service.

# KENT & STANLEY CO., LTD.,

JEWELERS AND SILVERSMITHS,

SEAMLESS GOLD FILLED CHAINS, JEWELRY,  
SILVER NOVELTIES.

NEW YORK OFFICE,  
21 and 23 Maiden Lane.



BOSTON OFFICE,  
403 Washington Street,

FACTORY, PROVIDENCE, R. I.

## NEW DESIGNS IN ALL LINES.

ALL OUR SILVER GOODS ARE GUARANTEED 925-1000 FINE.

# AJAX INSULATORS.

PATENTED OCTOBER 28, 1889.

THEY are Cheap; THEY Reduce Wear and Tear of the Case;  
THEY Protect from all Ordinary Magnetic Influences

Perfect in  
Action.  
Convenient  
in Use.



Educate  
Your Customers  
by Talking  
up  
Ajax Watch  
Insulators.

MADE IN ALL SIZES, OPEN FACE AND HUNTING,  
FOR SALE BY JOBBERS.

MANUFACTURED BY

## The Newark Watch Case Material Co

19 WARD STREET, NEWARK, N. J.

## The Bonner Combination

RING, STUD and SCARF PIN.  
A Long Screw and a Round Bezel.

Send for Selection Package

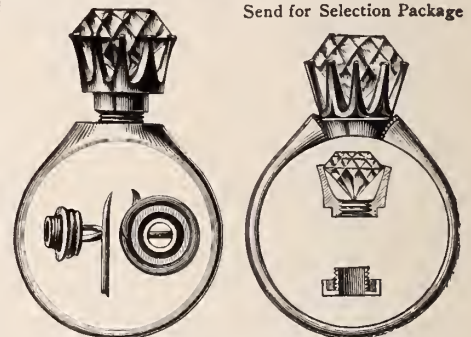

BONNER, RICH & CO.,

41 & 43 Maiden Lane, NEW YORK,  
604 Champlain Building, CHICAGO.

## CROUCH & FITZGERALD.

Jewelry Trunks  
and Cases,

161

Broadway,  
Bet. Cortlandt and  
Liberty Sts.,  
688 B'way,  
701 6th Ave.,  
NEW YORK.



# LEATHER GOODS FOR FALL.

NEW LINE NOW READY.

Comprises Full Assortments. . . . .



LEVANT.

**POCKETBOOKS,  
CARD CASES,  
BILL BOOKS,  
CHATELAINE BAGS  
and BELTS** in all lengths  
and widths.

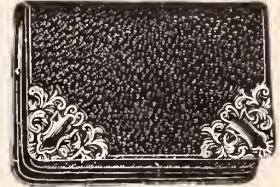

CREPON.

We manufacture all our own goods and use only Sterling Silver and Gold Mountings.

We have special facilities for filling

### MAIL ORDERS.

Such orders from dealers who have no account with us should, to receive prompt attention, be accompanied by New York City references.

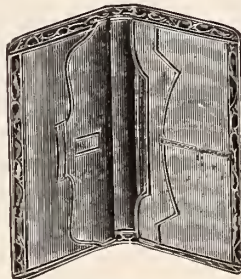

SEAL.

Also many other Novelties which cannot be enumerated in this limited space.

We have prepared an unusually fine and extensive line of these goods in anticipation of an increased demand for these popular articles in the fall. Exclusive and artistic patterns. Our prices are right.

65 NASSAU STREET,

(New Prescott Building.)

NEW YORK.

## W. F. EVANS & SONS

ESTABLISHED 1805.

SOHO CLOCK FACTORY,

Handsworth, Birmingham, ENGLAND.

TURRET CLOCK.

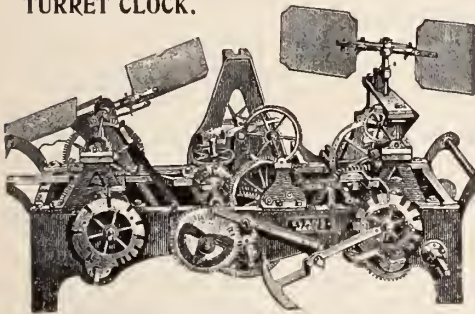

WESTMINSTER CHIMES.



GRANDFATHER CLOCK.

With arch brass dials to chime upon Bells, Gongs, and Harrington's Patent Tubes.

MANUFACTURERS OF

CHURCH,  
CHIME and  
QUARTER

### CLOCKS,

SCHOOL AND  
HOUSE CLOCKS.

## NEW ORNAMENTS

. . IN . .

### STERLING SILVER.



Many Designs in

Galleries, Belt Buckles,  
Belt Slides AND Belt Fastenings,

ALWAYS SOMETHING NEW.

## THOMAS W. LIND,

67 Friendship Street,

Manufacturer of  
JEWELERS' FINDINGS.

PROVIDENCE, R. I.

DON'T FORGET THE JEWELERS' CIRCULAR PUBLISHING CO.'S BOOK LIST when in want of any technical book in the Jewelry or Kindred Trades.

**Imports and Exports for May, 1896, and the Preceding Eleven Months.**

WASHINGTON, D. C., July 8.—The summary statement of imports and exports for the month ending May 31, 1896, and the 11 months ending the same date, compared with the corresponding periods of 1895, has been issued, and contains the accompanying figures relative to the jewelry trade.

The merchandise remaining in warehouse, on the last day of May, 1895 and 1896 respectively, was as follows:

	1895	1896
Clocks, etc.....	\$41,734	\$59,492
Watches, etc.....	15,459	33,294
Jewelry, etc.....	\$51,108	\$70,360
Precious stones, etc.....	22,277	15,895

**Superiority of American Silverware.**

“NEW YORKERS don't half appreciate their own markets,” said a man who has just returned from London to a New York *Sun* reporter, “and they frequently amuse English people by buying abroad articles that could be purchased to much greater advantage here. For instance, silverware. My observation of silver abroad leads me to believe that we have the most artistic workmen in that metal right here in New York. I picked up some handsome pieces of old silver in France, but I could find nothing modern that compared in design or finish to the articles exhibited by our best dealers. Several years ago a wealthy Englishman came to me in New York with letters of introduction. It was his first trip to this country, and he told me that he wanted to buy some gifts for his friends at home and he wanted to purchase something that should be a good example of American workmanship. He surprised me not a little by saying that he had heard our silverware spoken of very highly. I had never given the subject a thought, but I took him on a tour of inspection and he made a number of purchases. He was an expert on silver goods and he told me that this city offered a bigger choice than either Paris or London. Moreover, this reputation of

IMPORTS OF MERCHANDISE.

ARTICLES.	MAY.		ELEVEN MONTHS ENDING MAY—	
	1895	1896	1895	1896
	Values.	Values.	Values.	Values.
<b>CLOCKS AND WATCHES, AND PARTS OF:</b>	<i>Dollars.</i>	<i>Dollars.</i>	<i>Dollars.</i>	<i>Dollars.</i>
Clocks and parts of.....dut...	16,941	27,150	289,391	505,000
Watches, watch materials, and movements.dut...	79,158	68,683	935,595	1,016,718
<b>JEWELRY, MANUFACTURES OF GOLD AND SILVER, AND PRECIOUS STONES:</b>				
Diamonds and other precious stones rough or uncut, etc.....free...	6,713	7,916	553,792	112,288
Jewelry, and manuf'r's of gold and silver...dut...	35,633	67,225	584,673	999,108
Precious stones, and imitations of, not set...dut...	378,286	449,076	6,238,772	5,841,075
<b>Imported from—</b>				
United Kingdom.....	3,159	903	383,208	44,156
France.....	519	9	71,765	1,554
Netherlands.....			49,783	16,963
Other Europe.....	2,535	7,004	36,726	48,591
Brazil.....			11,367	
Other countries.....	500		943	1,381
Total diamonds, etc.....free..	6,713	7,916	553,792	112,288
United Kingdom.....	87,089	155,503	2,351,884	2,152,421
France.....	84,384	57,066	1,354,864	1,554,837
Germany.....	31,031	37,356	302,450	395,642
Netherlands.....	49,709	119,170	1,905,113	1,312,572
Other Europe.....	155,480	141,858	793,312	1,367,920
British North America.....	212	323	86,489	19,555
Mexico.....	5,766	4,357	14,656	28,525
East Indies.....	63		7,005	297
Other countries.....	221	668	7,711	8,714
Total jewelry, precious stones, etc.....dut..	413,919	516,301	6,823,445	6,840,183

EXPORTS OF DOMESTIC MERCHANDISE.

<b>CLOCKS AND WATCHES:</b>				
Clocks, and parts of.....	68,919	87,143	766,224	832,023
Watches, and parts of.....	41,262	61,296	329,750	486,157
Total.....	110,541	148,439	1,095,983	1,318,180
Jewelry, and manufactures of gold and silver..	79,525	40,037	674,952	757,403
Plated ware.....	30,194	26,789	314,737	371,176

EXPORTS OF FOREIGN MERCHANDISE.

<b>CLOCKS AND WATCHES, AND PARTS OF:</b>				
Clocks and parts of.....dut.....			137	311
Watches, and watch materials, etc.....dut...	16	2210	126	10,819
<b>JEWELRY, MANUFACTURES OF GOLD AND SILVER, AND PRECIOUS STONES:</b>				
Diamonds and other precious stones, rough or uncut.....free.....	2,141		2,141	
Jewelry, and manuf'r's of gold and silver...dut...	1,295	1,172	68,018	40,032
Precious stones, and imitations of, not set...dut..	5	40	14,509	3,189



THIS TRADE MARK MEANS THAT EVERY ARTICLE UPON WHICH IT IS STAMPED, IS **925-1000 PURE SILVER.**

IT ALSO MEANS THAT GOODS SO STAMPED ARE NOT SOLD TO DRY GOODS OR DEPARTMENT STORES, BUT ARE CONFINED TO THE LEGITIMATE JEWELRY TRADE.

NEW YORK,  
CHICAGO,  
SAN FRANCISCO.  
WORKS, PROVIDENCE.

**Gorham Mfg. Co.,**  
SILVERSMITHS.

New York is not new. I saw a few days ago some work that was turned out nearly half a century ago in this city by a silversmith named Adams. I don't know anything about Mr. Adams or what has become of him, but his work in design and finish was of the very highest order. I have recently been examining the work of silversmiths abroad and I have found it inferior to our own. Notwithstanding this fact, many people who go abroad purchase silver in London and Paris under the delusion that they are getting better work for less money."

Chas. F. Greene, for the past six years manager of Spaulding & Co., Paris, France, arrived in New York on the *St. Louis* on July 10, and expects to remain in this country about a month. During his absence E. J. Smith, of the Chicago house of Spaulding & Co., will attend to the interests of the Paris branch.

# TWO NEW PIECES FOR

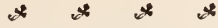

Where would we be if in a quiet season we decided to make **nothing new** till we saw a **demand**?

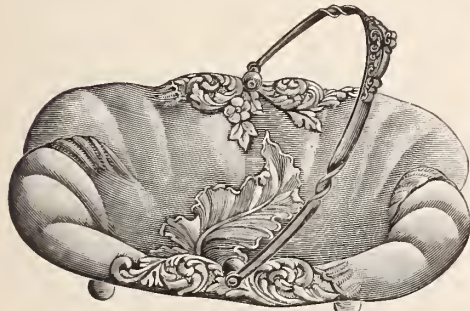

No. 6607. BON-BON DISH.



No. 2846. HAND MIRROR.

# EVERY DAY IN THE YEAR.



Make the **demand**. Sort up your stock with 25, 50 or 100 new pieces that will make people buy. We furnish goods that sell.



No. 1969. TRINKET TRAY.

FACTORIES,  
NEW BEDFORD, MASS.

SALESROOMS,  
NEW YORK. CHICAGO.  
SAN FRANCISCO. MONTREAL.

## PAIRPOINT MFG. COMPANY.

# CARBORUNDUM

THE GREATEST ABRASIVE YET DISCOVERED.

Four times the Labor and Expense-saving qualities of Emery, Corundum or other abrasives. Adapted for Lapidary Work, Grinding, Polishing and every operation where a perfect abrasive is necessary.

### Price List of Carborundum Wheels.

ACHESON'S PATENT, February 28th, 1893; February 26th, 1895.

DIAM. IN.	THICKNESS IN INCHES.																MAX. REV.
	1/8	3/8	1/2	5/8	3/4	1	1 1/4	1 1/2	1 3/4	2	2 1/4	2 1/2	2 3/4	3	3 1/2	4	
1	\$.15	\$.15	\$.20	\$.20	\$.20	\$.25	\$.30	\$.30	\$.35	\$.40	\$.40	\$.45	\$.50	\$.50	\$.60	\$.70	18000
1 1/8	.20	.25	.25	.25	.30	.30	.35	.40	.40	.45	.50	.55	.55	.60	.70	.75	14000
2	.20	.30	.30	.30	.35	.40	.45	.50	.55	.60	.60	.65	.70	.75	.85	.90	11000
2 1/8	.25	.35	.40	.45	.50	.55	.65	.70	.80	.90	1.00	1.10	1.20	1.25	1.40	1.50	8800
3	.30	.45	.55	.60	.65	.75	.85	1.00	1.15	1.25	1.40	1.50	1.60	1.75	2.00	2.20	7400
3 1/8	.40	.50	.65	.70	.80	1.00	1.15	1.30	1.45	1.65	1.80	1.95	2.10	2.20	2.55	2.90	6300
4	.50	.60	.75	.85	1.00	1.20	1.40	1.60	1.80	2.00	2.20	2.40	2.60	2.80	3.20	3.60	5500
5	.70	.85	.95	1.15	1.25	1.60	1.95	2.30	2.60	3.00	3.30	3.65	3.95	4.25	4.90	5.55	4400
6	.95	1.10	1.30	1.55	1.75	2.20	2.70	3.15	3.60	4.10	4.55	5.00	5.45	5.90	6.80	7.70	3700
7	1.25	1.45	1.65	1.95	2.30	2.95	3.50	4.15	4.80	5.40	6.00	6.60	7.20	7.80	9.00	10.25	3160
8	1.50	1.70	2.00	2.40	2.80	3.60	4.40	5.20	6.00	6.75	7.55	8.30	9.10	9.90	11.45	13.00	2770
9	1.80	2.10	2.40	2.90	3.35	4.30	5.30	6.25	7.25	8.20	9.15	10.10	11.10	12.05	14.00	15.90	2460
10	2.15	2.50	2.85	3.45	4.00	5.15	6.30	7.45	8.60	9.75	10.90	12.00	13.20	14.35	16.60	18.90	2210
12	2.65	3.10	3.70	4.50	5.25	6.80	8.40	9.95	11.50	13.05	14.60	16.20	17.75	19.30	22.45	25.50	1850
14			5.05	6.05	7.00	9.00	11.00	13.00	15.00	16.95	18.95	20.95	22.95	24.90	28.90	32.80	1580
16					9.10	11.70	14.30	16.85	19.95	22.00	24.55	27.15	29.70	32.30	37.40	42.50	1380
18					11.25	14.45	17.70	21.00	24.25	27.50	30.75	34.00	37.25	40.50	47.00	53.50	1230
20						17.50	21.55	25.55	29.60	33.70	37.80	41.90	45.95	50.00	58.00	66.00	1100

The wheels are made with a vitrified bond and pressed under hydraulic pressure. Those over three inches in diameter are turned up after firing. The same numbers are used to designate the degrees of fineness, as are used with Emery, and the wheels are made in seven degrees of hardness, marked SSS, SS, S, M, H, HH, HHH, from extremely soft to extremely hard. In ordering, state diameter, thickness, hole, number and hardness.

Hones, Slabs, Files.

CUT THIS OUT.

## THE CARBORUNDUM CO.

WORKS: MONONGAHELA, PA., AND NIAGARA FALLS, N. Y.

**DIAMONDS.**  
**Wm. S. Hedges & Co.,**  
 IMPORTERS OF  
**Diamonds and Precious Stones.**  
**DIAMOND JEWELRY.**  
**170 Broadway, New York.**  
 22 Holborn Viaduct, London.

**Alfred H. Smith & Co.,**

IMPORTERS

**DIAMONDS**

AND

PRECIOUS STONES,

**182 BROADWAY, COR. JOHN STREET,**

**NEW YORK.**

Venetian Building. **34 & 36 Washington St.**

**CHICAGO, ILL.**

**BATES & BACON**  
 "FAVORITE"  
 14K

**ALWAYS**

Ask to see  
 our

**BATES & BACON**  
 "ROYAL"  
 14K

**GOLD FILLED**  
**WATCH CASES.**

**None Better**

and

**BATES & BACON**  
 "PURITAN"  
 14K

**Few Equal.**

**HERMAN KOHLBUSCH, SR.**

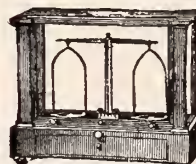

Established 1859  
 Manufacturer of  
**FINA BALANCES**  
 AND WEIGHTS for  
 every purpose  
 where accuracy is  
 required. 59 Nassau  
 Street, cor. Maiden  
 La. N. Y.

Repairs (any make)  
 promptly made



**SCHULZ & RUDOLPH,**  
 IMPORTERS AND CUTTERS OF  
**DIAMONDS AND OTHER PRECIOUS STONES,**

(Successors to JOHN E. HYDE'S SONS.)

Sole Agents for **The Celebrated Jules Jurgensen Watches.**

**28 JOHN ST. and 65 NASSAU ST., NEW YORK.**

# The Bowden Rings

ARE COMPLETE IN VARIETY, CORRECT  
 IN QUALITY AND PERFECT IN FINISH.  
 WE MAKE EVERY VARIETY OF FINGER  
 RINGS

**J. B. BOWDEN & Co.,**

**3 MAIDEN LANE,**

**NEW YORK.**

## Death of a One-Time Prominent Importer.

Robert C. Melvain, of the old and at one time well known firm of Tomes' Son & Melvain, died in Wyoming, N. J., Wednesday last. Mr. Melvain was 68 years old. As a young man, before the war, he was a traveler for the firm of Francis Tomes & Son, importers and general jobbers of jewelry, fancy goods and cutlery, 6 Maiden Lane, New York. The firm had a large southern trade, which Mr. Melvain canvassed for them and he became well known in the south. So valuable were his services that he was made a partner during the early '70s, the firm name being changed to Tomes' Son & Melvain. With the dissolution of the firm, Mr. Melvain's connection with the jewelry trade ceased. Funeral services were held Friday afternoon at his late home in Wyoming, N. J.

## Death of Paul A. Jeannot.

RED BANK, N. J., July 15.—Paul A. Jeannot, a former watch case manufacturer of New York, fell from his bicycle at Little Silver, at four o'clock this afternoon, and made no effort to rise. The man was unconscious. Dr. Thomas E. Ridgway, of Red Bank, drove up shortly after, and was called in, but the man had died. The physician said that death was due to heart failure.

Paul A. Jeannot lived at 130 W. 95th St., New York. He was born in Switzerland 51 years ago and at one time was in the watch case business, but of late years was a gilder and plater in Maiden Lane. He was a cousin of A. A. Jeannot, of Jeannot & Shiebler. He leaves a widow. The deceased was Quartermaster Sergeant of the 7th Regiment, N. G. N. Y. The funeral services were held at his late residence, Saturday afternoon. Interment was in Woodlawn Cemetery.

"I wonder," said Jeweler Cross to a reporter of the Amsterdam, N. Y., *Daily Democrat* the other day, "whether the people who are howling for free silver have noticed that for some time we jewelers have been selling spoons made of coin silver for their weight in silver dollars. And I wonder, if they have noticed it, whether it has dawned upon any one of them that we get our profit and the pay for the work necessary to make the spoons out of the difference between the real value and the fictitious value of the dollars. We have been able to do this simply because the gold standard is behind the fictitious value of the silver dollar. If free coinage were established the purchaser would have to add to the weight of the coin that would equal the weight of the spoons, the amount required to pay our labor and give us our profit. There is an object lesson for you."

General manager W. H. Lyon, of the Charles Parker Co. industries, Meriden, Conn., said that all their factories would start up July 20 that had been shut down; some of the factories had been running through the vacation. It looks now as if the working time would be 50 hours until further orders.

**Latest Fashions in Paris.**

NEW PATTERNS IN BRACELETS—POPULARITY OF VEIL PINS—JEWELLED BANDS WORN ON THE COLLAR.

PARIS, France, July 10.—New patterns of bracelets are constantly coming out. At one of the best Rue de la Paix stores, we noticed a pretty bracelet showing a floral design entirely formed of varicolored stones, mounted so lightly that they seem to hold together by magic; two rows of tiny white pearls frame the design. Another bracelet consists of a succession of bezels in a shape resembling that of a marquise ring, bordered with brilliants; a double garland of minuscule jeweled flowers run between these bezels, which contain each a miniature portrait of an eighteenth century beauty. A very artistic one shows a light conventional foliage like a delicate arabesque, formed of narrow bands of gold and platina most daintily chased. A curious bracelet exhibits a quaint Merovingian design on a ground of granulated gold, giving a vague effect of filigree work. Many consist of a tasteful association of faceted stones and *cabocons* arranged in all kinds of graceful designs. An original bracelet exhibits a succession of jeweled shells of a fantastic shape resting on piky sea-weeds in green gold. Bracelets in open work are used as borders for the wrists of the sleeves.

A great variety of veil pins are worn. They consist of a bar with a chain hanging from it that holds a ball into which the point of the pin is caught when fastened. It is used to gather the top part of the veil and to fix it on to the hat. The pin is either straight or twisted, in plain or chased gold with additions of gems. It may be made in the shape of a sprig of flowers, a narrow leaf or a lizzard. The chain may be a light garland, etc.

Two jeweled bands are worn on the collar of a dress in a way to look like a tight necklace broken in front and at the back, a handsome brooch being fastened in each of the two empty spaces.

JASEUR.

**Death of Maj. George Duffey.**

WASHINGTON, D. C., July 15.—Maj. George Duffey died July 10 at his residence. Maj. Duffey was born in this city 76 years ago, and was one of the best known citizens. When a young man he learned the watchmaking trade, and after he had finished his trade he started a business, which he conducted until 1895. Forty years ago he was elected Commissioner of Revenue, which office he held until the breaking out of the war, when he joined Kemper's Battery, and became well known for his bravery. He was much liked by Gen. R. E. Lee. At the close of the war he returned to his home and started in business again. He was re-elected Commissioner of Revenue about 20 years ago, and held that office until the day of his death.

Deceased was an ardent Southerner, and his love for the South and its people was indirectly the cause of his death. Last week he

ESTABLISHED 1840.

**RANDEL, BAREMORE & BILLINGS**

IMPORTERS OF

**DIAMONDS,**

AND OTHER PRECIOUS STONES.

**FINE PEARLS A SPECIALTY.**

MANUFACTURERS OF

**DIAMOND JEWELRY**

A Large Stock of Fine Mounted Goods Constantly on Hand.  
Goods Sent on Approval and Insured in Transit.

Diamonds Cut, Recut and Repaired.

58 Nassau Street,  
29 Maiden Lane.  
NEW YORK.

1 Tulp Straat,  
AMSTERDAM.

1 St. Andrew's St.,  
Holborn Circus,  
LONDON E. C.

ESTABLISHED 1841.



**CARTER, HASTINGS & HOWE,**

MANUFACTURERS OF

**GOLD JEWELRY,**

**15 MAIDEN LANE, NEW YORK.**

A. CARTER

C. E. HASTINGS,  
W. T. CARTER,

G. R. HOWE,  
W. T. GOUGH

FACTORY, NEWARK, N. J.

**WOOD & HUGHES,**  
STERLING SILVERWARE MANUFACTURERS  
New York Agents for the Derby Silver Co.,  
FINE QUADRUPLE PLATED WARE  
No. 16 JOHN STREET, - NEW YORK.  
206 Kearney St., San Francisco, Cal.  
HASKELL & MUEGGE, Agents.

**FERD. FUCHS & BROS.**  
**SILVERSMITHS.**  
MAKERS OF STERLING SILVERWARE,  
808-810 Greenwich St., - New York.

ARE always of **Standard Quality**, of **Newest Styles** and **Best Finish**.

They will always sell when anything will, and cost no more than those of doubtful reputation.

Don't wait for our travelers, but send direct to



**Oldest Ring Makers in America.**

**M. B. BRYANT & CO.,** 10 Maiden Lane, N. Y.

### NYE'S SUPERFINE OILS.

Special grades for



CHRONOMETERS, WATCHES, CLOCKS, JEWELERS' LATHES, ETC., ETC.

NYE'S OILS acknowledged SUPERIOR TO ALL OTHERS.

WM. F. NYE, Manufacturer, New Bedford, Mass.

We carry the largest, finest and most complete line of Mounted Diamond Jewelry of any house in America.



### JACOT & SON, Musical Boxes.

Importers and Manufacturers of

39 Union Square New York

**SECURITY PIN GUARD**  
 PAT'D DEC. 25, 1894  
 MANFD BY SECURITY MFG CO. **25¢**  
 7 ASTOR HOUSE (BROADWAY) N.Y.  
 85c. doz. Net Cash. Discount to Jobbers

SEND FOR CATALOGUE of books for the jewelry and kindred trades. Just issued. JEWELERS' CIRCULAR PUB. CO., 189 B'way, N. Y.

### KETCHAM & McDOUGALL,

MANUFACTURERS OF

### GOLD AND SILVER THIMBLES

ESTABLISHED 1832.



TRADE-MARK.

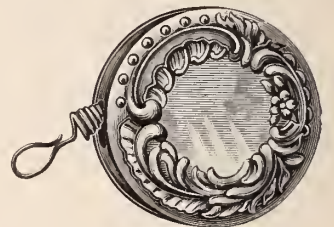

Pat'd Nov. 20, '94.



No. 149

And the improved **Automatic Eye-Glass Reel.**

SEND FOR CATALOGUE C.

198 BROADWAY, NEW YORK.

### AIKIN, LAMBERT & CO.,

MANUFACTURERS OF

FINE GOLD PENS, HOLDERS, PENCILS, TOOTH PICKS, and NOVELTIES.

PAUL E. WIRT FOUNTAIN PENS, at new and lower prices . . . .  
MERCANTILE FOUNTAIN PENS, guaranteed to give satisfaction.

Catalogues with terms and discounts furnished to the trade.

BRANCH, 103 STATE STREET, - - - CHICAGO.

19 MAIDEN LANE, NEW YORK.

### AIKIN-LAMBERT JEWELRY CO.,

IMPORTERS OF

### DIAMONDS.

JOBBER IN

WATCHES, JEWELRY, CHAINS NOVELTIES, ETC.

LATEST DESIGNS.

LOWEST PRICES



attended the corner-stone laying of the Jefferson Davis monument at Richmond, and the fatigue of the trip, the change of water, and the intense heat completely prostrated him. When he returned home he took to his bed. He leaves a mother, who is 98 years old. The funeral was attended by R. E. Lee Camp, Andrew Jackson Lodge, A. F. and A. M., and Oriental Lodge, K. of P.

**Peculiar Methods of the Interstate Importing & Mfg. Co.**

SYRACUSE, N. Y., July 20.—Harry C. Flood, who came to this city last Fall to take active part in the management of the Interstate Importing & Manufacturing Co., is locked in a cell at the police station on a charge of obtaining money under false pretences. The warrant was sworn out by Homer J. Nodine, a retail cigar and tobacco dealer, who charges that Flood obtained \$23 from him on a worthless draft. Flood is a son of Dr. T. L. Flood, a wealthy resident of Meadville, Pa. It is claimed by Flood's friends that the matter is a mistake, and that it can be readily adjusted. Owing to the fact that Flood has been on a protracted spree, no one was willing to sign a bail bond and he was compelled to remain in confinement.

The arrest of Flood Saturday afternoon and the previous proceedings in the Supreme Court Saturday morning, when a receiver was appointed for the Interstate Importing & Manufacturing Co., brings to light a state of facts that foreshadows something even more interesting. It is the story of the formation of a company on air and incidentally the making of false affidavits and the carrying on business in a way that is at least remarkable. The Interstate Importing & Manufacturing Co. was formed last November by Charles A. Lockhard, who was then the manager of the Warners Portland Cement Co., Harry C. Flood and Edward A. Kingsbury. Two thousand shares of stock were issued at \$5 a share, of which Lockhard subscribed for 998 shares, Flood for 997 shares and Kingsbury for 5 shares. The business proposed to be carried on was the jobbing of small jewelry. Lockhard subsequently sold 20 shares of his stock to Ephraim J. Page, the attorney. Lockhard was president of this corporation and had the sole management of it, Kingsbury acting as bookkeeper. In the office of the Secretary of State at Albany and the Clerk of Onondaga County were filed affidavits in which it was set forth that \$10,000 capital stock of the concern was fully paid. It is now charged by the creditors of the concern that these affidavits were false and that but \$1,800 was actually paid, this sum consisting of a small amount of personal property, a claim by Flood in personal effects for services, and the trade-

mark "Kimberly Gem," for imitation stones.

On the strength of the affidavits regarding this fully paid-in stock, the company had no trouble in securing a line of credit with wholesale jewelers and various periodicals in which they advertised extensively. Orders came in fast and thick from people all over the country who wanted "diamonds for \$1," and the goods were shipped C. O. D.

The liabilities of the concern aggregate nearly \$4,000 and there are no assets whatever, except claims for unpaid stock. Suit has been brought against Lockhard to recover the \$1,500 which he owes. A short time ago Lockhard resigned from the presidency of the company, issued all the stock to Flood as full paid, excepting about five shares, took a note for \$900 in return, payable in one year from date, and retired to private life. If the note is not paid at maturity the stock will revert to Lockhard.

The stock book of the company shows a peculiar state of affairs. The dates contained therein, as the dates when stock was issued, are all later than the filing of the affidavit which showed that the capital was fully paid. They are as follows: March 28, 1896, 5 shares to Lockhard, 20 shares to Lockhard, 200 shares to Flood, 100 shares to Flood, 20 shares to Flood, 20 shares to Flood, 20 shares to Flood, 4 shares to Flood, 4 shares to Flood, 4 shares to Flood, 4 shares to Flood, 5 shares to Kingsbury, 74 shares to Flood, 480 shares to Flood, 20 shares to Flood, 1,000 shares to Flood; January 3d, 20 shares to E. J. Page. At a meeting of creditors recently held Flood explained the situation of affairs frankly, it is said, and showed the books of the company. He claimed that had Lockhard acted squarely all would have been right.

**Provisions of the Will of Morris Sickles.**

PHILADELPHIA, Pa., July 18.—The will of Morris Sickles was admitted to probate by Register of Wills Smithers, on July 14. It disposes of an estate valued at about \$40,000. The testator bequeaths \$150 to the Jewish Hospital Association of Philadelphia; \$150 to the Jewish Foster Home and Orphan Asylum; \$100 to the Hebrew Educational Society; \$100 to the United Hebrew Charities of Philadelphia, and the residue of the estate, except his interest in the firm of M. Sickles & Sons, to his widow, Hanchen Sickles, for her lifetime. At her decease, the will directs, it is to go to their children. The executors and trustees are directed to continue his interest with the firm as long as they think advisable, and they are empowered to withdraw it at any time or arrange with the other members of the firm to wind up the business. The widow and eldest son are named as executors.

**THE SIMPLEST STRONGEST AND BEST SKIRT SUPPORTER MADE.**

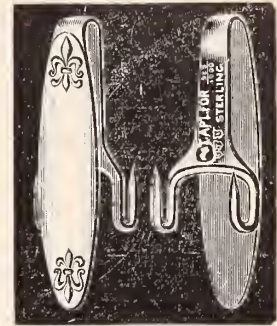

Twin Hooks Hold Skirt Waist and Skirt Immovably.

MADE OF A SOLID PIECE OF STERLING SILVER WITHOUT SOLDER.

Prices to the Trade in Plain Sterling.  
 1 in. \$5.00 per doz. | 1½ in. \$7.00 per doz.  
 1¼ in. 6.00 " | 2 in. 8.00 "

Rose Gilding, \$2.00 per dozen Extra.

Made in plain Sterling, Sterling Gilt and 14K Gold, of Heavy Weight, Only.

A VARIETY OF PATTERNS.

**THE TENNANT Co.,**  
 SILVERSMITHS,  
 33 Union Square, N. Y.

**..NOVELTY.. Hat Guards.**

EVERY MAN WANTS ONE.

Sterling Silver  
 .925 Fine  
**\$4.50**  
 Per Dozen.

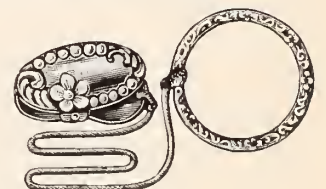

**S. C. POWELL,**  
 51 and 53 Maiden Lane, N. Y.

**SPECIAL IN THE JEWELERS' CIRCULAR**  
 Produce the results desired.

**NOTICES**

WE MAKE  
  
 STOCK FOR

CANE HEADS,  
 UMBRELLA MOUNTINGS,  
 PENCIL-CASES,  
 WATCH-CASES,  
 WATCH-CROWNS,  
 THIMBLES,  
 SPECTACLE AND  
 EYE-GLASS BOWS,  
 DIAMOND MOUNTINGS  
 &c., &c., &c.

ESTABLISHED 1849.

INCORPORATED 1890.

**J. BRIGGS & SONS CO.,**

MANUFACTURERS OF

**Gold and Silver Plate and Seamless Wire,**

65 CLIFFORD STREET, PROVIDENCE, R. I.

## Retail Jewelers in Convention.

ATLANTIC CITY, N. J., July 18.—Thoroughly pleased with the results of their deliberations in business conclave, and favorably impressed with the mid-Summer importance of this delightful seashore resort, the retail jewelers who have been in convention here this week have departed for their respective homes. Two conventions were virtually held in one. Two organizations were represented, and although they held separate sessions the business of one possessed features



RICHARD O'NEILL,

PRESIDENT-ELECT, NATIONAL RETAIL JEWELERS' ASSOC'N.

of interest for the other. Being so closely affiliated, all was peace and harmony among the delegates to the different conventions and they performed all work smoothly and effectively.

On Tuesday, July 14, the seventh annual convention of the Pennsylvania Retail Jewelers' Association was held in Haddon Hall and was presided over by Isaac Herzberg, president of the organization. Other officers are as follows: Asa Collier, 1st vice-president, Plainfield, N. J.; R. Pinkstone, treasurer, Philadelphia; Chas. H. Hamer, secretary, Philadelphia board of directors, John R. Hamer, Simon C. Levy, S. L. Schumo, Wm. Haines, G. M. D. Lewis, Geo. S. Katz, C. Boud Cole, E. J. Daugherty, F. C. Bode, Chas. B. Lynch, E. H. Williams, O. O. Stillman, C. L. Conrad, J. W. Smith, J. B. Janssen.

After President Herzberg had delivered an address of welcome, Simon C. Levy, of Philadelphia, spoke on the subject, "What Constitutes Hard Times for the Retail Jeweler?" He advised his hearers to make a liberal use of printers' ink, and classed the department stores as one of the greatest evils ever experienced by the retail jewelry trade. After referring to the impositions made by handlers of bogus jewelry, he added, "Let us as retail jewelers use our best efforts to sell only reliable goods and thus gain the confidence of patrons by serving them rightly."

This was followed by the transaction of routine business, and at 4 o'clock P. M. an

adjournment was taken and an excursion to the Inlet and Brigantine Beach was enjoyed by both State and National delegates. At 8 o'clock in the evening another session was held, which was followed upon adjournment by a social reception and smoker.

### THE NATIONAL ASSOCIATION MEETING.

On Wednesday the National Retail Jewelers' Association held their fourth annual convention. The officers were: Herman Mauch, president, St. Louis, Mo.; O. O. Stillman, 1st vice-president, New Brunswick, N. J.; Richard O'Neill, 2d vice-president, Lincoln, Neb.; W. F. Kemper, secretary, St. Louis, Mo.; Ed. G. Lohmeyer, treasurer, Newport, Ky.

A feature of the opening of the convention was the presentation to President Mauch of a handsome silver gavel, with gold bands and encased in a blue silk casket. It was a tribute from the Retail Jewelers' Association of Missouri, and the presentation speech was made by W. F. Kemper, as the president of the State branch. The day was passed by the delegates to the convention, their wives and friends, in a mingling of business and pleasure. At 9 o'clock A. M. a business session was opened in the parlors of Haddon Hall, with President Mauch in the chair. The presentation of delegates' credentials to the national secretary, roll call of the national officers and delegates, the reading of the minutes, reports of officers and standing committee and other routine business occupied the attention of the convention till noon, when an adjournment was taken and one and all joined in a pleasurable dip in the surf.

The short afternoon session included the reading of the reports of delegates and presentation of resolutions and recommendations, and the appointment of committees to consider the same. W. T. Lewis, president of the Philadelphia Horological Society, delivered an address on "The Conditions which Render Watch Repairing Profitable." He was

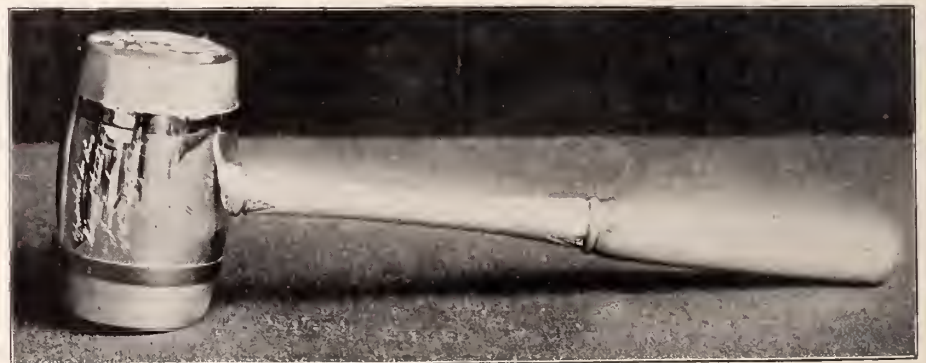

GAVEL PRESENTED TO THE RETIRING PRESIDENT OF THE NATIONAL RETAIL JEWELERS' ASSOCIATION.

followed by several members who made brief remarks, and at three o'clock the convention adjourned to allow the delegates to enjoy a sail.

After a brief session in the evening the jewelers accepted an invitation to witness the children's carnival at the Ocean Pier.

After adopting resolutions of interest to the trade and electing officers for the ensuing year, the convention came to a close on Thursday. The officers elected were: Presi-

dent, Richard O'Neill, Lincoln, Neb.; vice president, O. O. Stillman, New Brunswick, N. J.; secretary, F. A. Hannis, York, Neb.; treasurer, Asa Collier, Plainfield, N. J.

The association at the last day's session adopted a new constitution, placing the organization on a more thorough business basis, and also adopted a resolution favoring the formation of a jobbers' association, with headquarters in New York city. The following resolution was also favorably acted upon:

WHEREAS, A great amount of gold and silverware is offered for sale on bargain counters that is of necessity of inferior quality and not of the grade represented, on account of the low price charged;

Resolved, That the public be advised to patronize one line jewelry dealers in preference to the department stores, which latter have monopolistic tendencies.

A further resolution was adopted urging manufacturers and jobbers of gold and silver goods to sell their wares to only legitimate jewelers, to the exclusion of the department stores.

Detroit, Mich., was settled as the next place of meeting and a resolution was adopted declaring in favor of one cent postage. A petition to this effect will be forwarded to Congress by the proper officials.

## A. B. Kennedy's Plan to rob C. D. Peacock of \$20,000 worth of Diamonds.

CHICAGO, Ill., July 18.—A. B. Kennedy evidently believed in aiming high, regardless of his means of accomplishment. After going to a man's boarding house and robbing him, he again returned and remarked: "Bouthillet, you are a fool. Come with me and make some money. Have you a revolver? No. Then we will hold up a street car conductor and get enough money to buy you one. We will rob Peacock's big jewelry store and get \$20,000 worth of diamonds. I have been in this business five years, and have made

\$30,000."

Bouthillet pretended to fall in with the visitor's scheme, and the two agreed to meet Tuesday evening at Peacock's to look over the ground. Kennedy did not keep the appointment and Bouthillet went to Chief Badenoch and told him the story. Later Kennedy was arrested. He was wearing Bouthillet's clothes and watch chain, and had a bottle of chloroform, a patrol box key and some pawn tickets in his pockets.

WE CALL THE ATTENTION OF THE TRADE TO  
OUR EXTENSIVE LINE OF : : : : :

. . . DOMESTIC AND IMPORTED . . .

# Porcelain Clocks

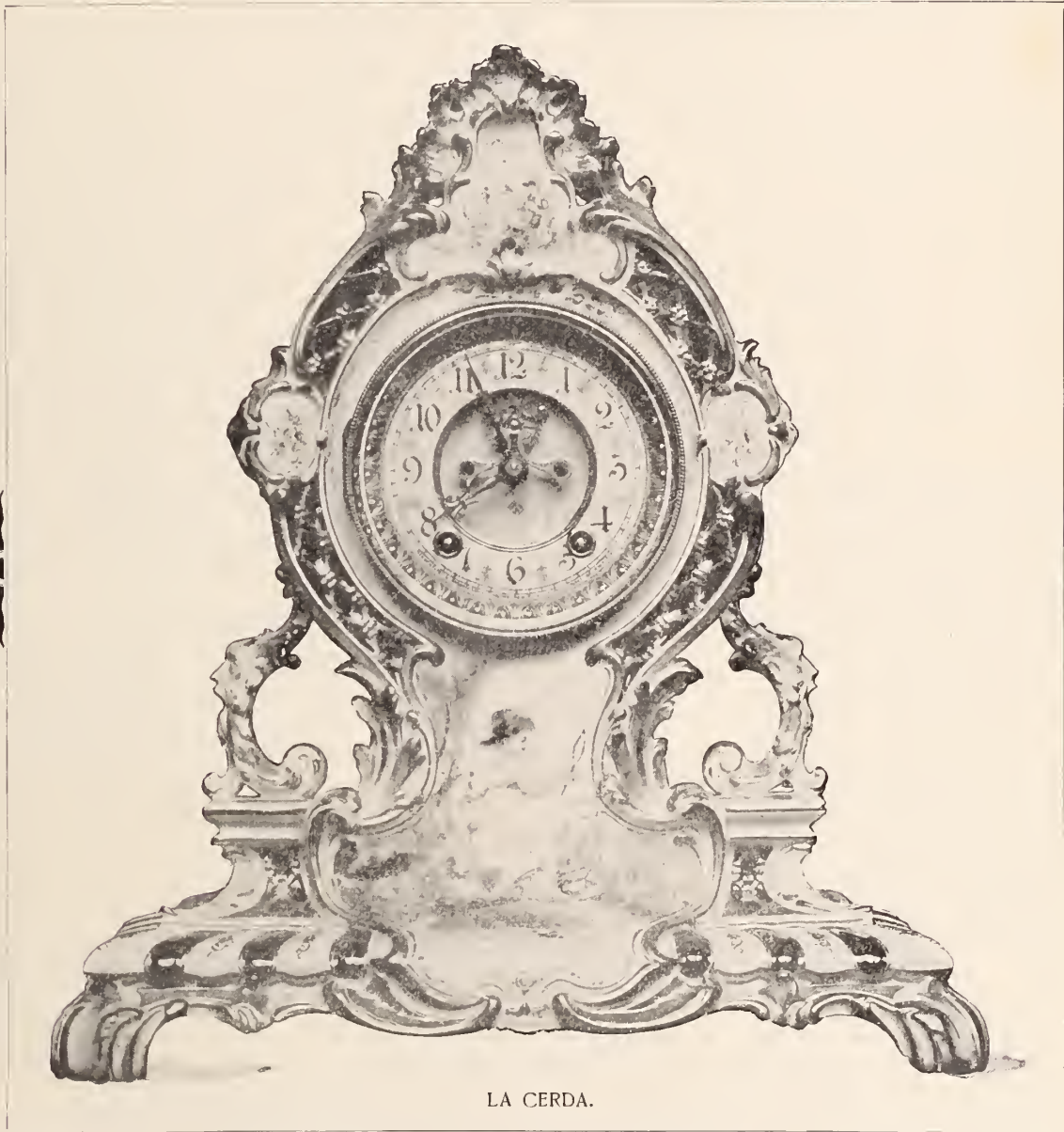

LA CERDA.

CHICAGO,  
133, & 135 WABASH AVE.

LONDON,  
23 FORE ST. E.C.

THE  
**ANSONIA CLOCK COMPANY,**  
11 CLIFF STREET,  
NEW YORK.



CABLE ADDRESS "ANSONIA".



P. O. Box 2304.

## Plan for a Watch Jobbers' Association Defeated.

The convention of jobbers in American watches, called for Wednesday morning, July 15, lasted but an hour, and as an attempt to form a new organization in the jobbing trade proved a failure.

At 10 o'clock A. M., the hour appointed for the meeting, the banquet hall of the Café Savarin, in the Equitable building, contained but a handful of representatives from the wholesale watch trade. Later the jobbers commenced to arrive, until at 10:45 o'clock there were about 25 men in the room. The meeting was then called to order by Jas. H. Noyes, the secretary of the old National Association of Jobbers in American Watches, who bid the jobbers welcome in the name of the committee, and asked for nominations for a chairman of the meeting. David Keller, of Keller, Ettinger & Fink, was nominated and elected, but he declined to act. H. H. Butts, of Hayden W. Wheeler & Co., was then nominated but refused, and in turn nominated A. V. Huyler, of N. H. White & Co., one of the committee in charge of the movement for organization. Mr. Huyler also declined and Mr. Keller, who was first elected, was prevailed upon to preside. After the chairman called the meeting to order with a few brief remarks, Jas. H. Noyes was made secretary.

Chairman Keller then asked Mr. Huyler, as one of the committee, to explain the purposes of the convention. Mr. Huyler said that the movement for a convention had been started by a circular signed by 12 firms, and at a meeting, he and E. S. Smith, of Smith & North, were appointed a committee to arrange for a convention of jobbers. Mr. Noyes, he said, was more familiar with the work that had been done, and he called on him to explain.

S. F. Myers objected to Mr. Noyes taking the floor on the ground that he was neither a jobber nor a wholesale dealer in watches. Mr. Keller gave Mr. Noyes the floor. The latter explained that the convention was not called at his own motion but resulted from the following circumstances: After the settlement of the Dueber suits, said Mr. Noyes, he learned that a number of meetings of jobbers had been held, and he was waited upon and requested to assist in getting up a plan for a new organization. After consulting with the manufacturers and finding the majority favorable to the formation of a new jobbers' association, a subscription paper was circulated to obtain the means to hire counsel to draw up a plan. The amount was subscribed and Elihu Root was retained to do the work, as he, having had charge of the defendants' case in the Dueber suits, was believed to be most conversant with the watch trade and the laws relating to it.

When the plan was drawn up, a committee was formed and authorized to see the trade. Mr. Huyler visited the jobbers in Boston and the east, and Mr. Noyes went to Chicago, Philadelphia, Cincinnati and the west. Mr.

Noyes said that most of the jobbers whom he saw received the plan favorably and were in favor of a convention. A committee was then appointed and the convention called.

Mr. Myers asked Mr. Noyes to name the firms who attended the meeting at which this committee was appointed. The latter replied that he did not remember all, but knew that the following attended: N. H. White & Co., Smith & North, J. T. Scott & Co., Aikin-Lambert Jewelry Co., R., L. & M. Friedlander, Roseman & Levy, C. K. Colby and David Marx. The call for the convention, Mr. Noyes explained, was signed by a large number of jobbers outside New York.

In speaking of the plan proposed by Mr. Root, Mr. Noyes said that the gist of the whole plan was in the last part of it. The rebate system, he was informed, had been successful in various other industries, and had three excellent points: 1st, the treasurer always had on hand a sum sufficiently large to make the members desire to keep from losing it; 2nd, members did not have to be tried as under the old system, but must swear they did not cut prices before collecting their rebate; 3rd, the penalty would not exclude members from doing business or from buying goods.

A. G. Schwab, Cincinnati, O., suggested that before going into details about plans it would be well to ascertain the sense of the meeting upon the question whether or not they wished to organize. The chairman, therefore, called for the views of those in attendance.

H. H. Butts, of Hayden W. Wheeler & Co., arose to state that his firm were utterly opposed to an association of jobbers. It was the business of the manufacturers to keep up prices and outside this question, he thought it a poor time, on the eve of a political election, to attempt to advance prices. The object—the improvement of the watch business—was a worthy one, but he was opposed to the plan submitted. Other jobbers agreed with the remarks of Mr. Butts.

D. F. Appleton, who arose to answer a question, was asked his views. He said that he thought it extremely desirable that the jobbers be able to maintain prices and promised that his firm would assist them in every way. As to the plan, he did not know whether or not it was the best one, but thought as it came from an eminent lawyer who had studied the laws of various States, it could not be illegal. He advocated an association. Mr. Schwab, who followed Mr. Appleton, said that while he was in favor of maintaining prices he was against this movement. The jobbers of his city, Cincinnati, had passed a few days before a unanimous resolution to the effect that they were opposed to a new association.

He recalled the history of the old association and said that the manufacturers had not supported it in good faith. The manufacturers should first come together and see if they can agree among themselves as to prices. Mr. Schwab moved that it was the sense of the meeting that the jobbers do not form an association.

David Keller asked if it would not be better before taking action to find out what the manufacturers proposed to do. He defended the manufacturers' actions under the old association, and said the blame was with the jobbers. Among honest men and gentlemen a police force was not necessary to make a man keep his word. He was on the old committee and heard all cases from the beginning, and it was his opinion that an association of this kind cannot be successful unless they control the output of the manufacturers. The jobbers, he said, had no confidence in one another, and an association was an impossibility.

Mr. Appleton, in speaking again on the subject, said that the only proper way to maintain prices was to ask a reasonable profit and insist on getting it. The rule should be how *dear*, not how *cheap* goods may be sold. The manufacturers, he said, were desirous of acceding to any plan by which the jobbers would get the largest profits.

S. F. Myers contended that the conditions of the trade and country at the present time were such that it would be suicidal to attempt to form any association. The supply of watches now was greater than the demand, and prices could not be kept up. The old combination was satisfactory for a time, but present conditions were entirely different from the old.

Mr. Schwab then put his motion in the form of a resolution which read:

*"That it is the sense of this meeting that it is inadvisable to form a jobbers' association in American watches and watch cases at the present time."*

The resolution was amended by striking off the words "at the present time," and as so amended was passed without a dissenting vote. The meeting then adjourned *sine die*.

## The H. W. Ladd Co. Settle with Their Creditors at 60 per cent.

PROVIDENCE, R. I., July 16.—The creditors of the H. W. Ladd Co., who failed last December, yesterday received checks for 60 per cent. of their claims upon that firm. It was the first and final dividend to be paid. That such a large percentage should be paid came in the nature of a surprise to the majority of the business men interested. At the time of the failure the general opinion was expressed that not more than 25 per cent. would be paid, and even the most sanguine would not go above 50 per cent.

The assignee, James M. Scott, yesterday made out the checks which paid the creditors 60 cents on the dollar and they were all made during the day. They amount to over \$100,000. Mr. Scott expressed himself as surprised somewhat at the outcome, and said the result exceeded his hopes. Isaac L. Goff bid in the book accounts which aggregated about \$10,000, for \$350.

J. N. Leclerc, Montreal, Can., has assigned on demand of Arthur Leclerc. Liabilities, \$1,080.

**Connecticut.**

C. H. Tibbits, Wallingford, has returned from a trip to Montreal.

D. J. Katz, Ansonia, has removed to his former home in New Haven.

The shops of the Phelps & Bartholomew Co., Ansonia, resumed work July 20.

The factories of the Gilbert Clock Co., Winsted, resumed operations July 13th.

C. W. Neal, who has conducted a jewelry business in Bristol a number of years, will sell out.

The Bradley & Hubbard Mfg. Co., Meriden, started up the works July 13th in nearly all departments.

R. N. Johnquest, optician, Ansonia, will open an optical store at 140 Bank St., Waterbury, about July 20th.

The German silver department of the Bristol Brass and Clock Co. started up July 13th, after a shut-down of two weeks.

Arthur Bradshaw, traveling salesman for the Meriden Britannia Co., left July 14th, on a business trip in New York State.

At the Meriden Silver Plate Co. it was stated that the works would probably start up Monday, July 20, in all departments.

John G. Shepard, of Windsor, has opened a clock repairing shop at his home, and is also a special agent of the New Haven Clock Co.

Commissioners were appointed on the Robert H. Curtis' estate, Meriden, by Probate Judge Thayer. They are Judge James P. Platt and attorney E. A. Merriman.

C. Rogers & Bros., Meriden, began the new Summer schedule with full time in all departments July 13, and report a very encouraging outlook for the Fall trade.

The New Haven Clock Co.'s factory will start up again soon. A few of the hands have been working for some time on special orders, chiefly for watches and marine clocks.

The estate of Breckbill & Benedict, Bridgeport, inventories at \$6,830.92, being composed of the stock and fixtures of the store and the equity in some real estate in Danbury.

The Biggins-Rodgers Co., Wallingford, started up July 20th. A big order for goods has been received. Simpson, Hall, Miller & Co. and the Watrous Mfg. Co. started up July 20th.

The Seth Thomas Clock Co. closed their factory July 16 for two weeks. This shut-down is usual in the Summer time. Business has been fairly good with the company the past six months.

In addition to the branches which were running at the Meriden Britannia shops the week of July 6-13, the lathe burnishing room employes resumed work July 13. All the other departments started up July 20.

Fire damaged the store in South Norwalk occupied by jeweler Richard Noack and others last week to the extent of \$1,800. Mr. Noack's individual loss is estimated at about \$250. There was no fire in the store during the day, and it is thought that the fire started from a match or cigar thrown on the floor, or from a spark from an engine on the Danbury division coming in through a window which was open.

Gen. George H. Ford, president of the Connecticut Jewelers' and Opticians' Association, says the call for the annual meeting of the association will be issued in a few days. He says the association work of the year has been most satisfactory and of great benefit to the trade; especially so have been the results of the gold and silver stamping law, while its benefits will be lasting and important to the entire jewelry trade of the State.

**Boston.**

Arthur H. Pray, diamond dealer, is taking a brief outing at Sunapee Lake.

Oscar Lane, Boston representative of Reed & Barton, has transferred his headquarters from 403 Washington St. to the Parker House.

Mr. Bogle, of the Bogle Bros. Co., who gave up business here on account of failing health, is reported as much improved by his return to White River Junction, Vt.

Recent letters from Willard Harwood, of Harwood Bros., who is now in Europe, state that he and his son will be in Paris and London this week and return shortly to Boston.

Among the creditors of Harry Askin, the insolvent manager of the Summer season dramatics at the Tremont Theater, this city, are J. B. Humphrey and George A. Carpenter, for small sums loaned to the manager.

A. D. Munroe and H. S. Lane, who have been for a number of years in the employ of Reed & Barton, Taunton, Mass., have bought out the business of George H. Whitford & Co., at 403 Washington St., room 5, this city, and will continue it under the firm name of Munroe & Lane. Henry T. Hartwall, who has been connected with the establishment about 30 years, will remain under the new management.

**Philadelphia.**

B. F. Griscom, of Bippart & Co., Newark, N. J., an old Philadelphian, sails for Europe July 22nd.

J. Warner Hutchins has been enjoying a week of pleasure at his club house near Atlantic City.

J. C. Buck & Co. have removed from the northeast corner of 6th and Commerce Sts. to 9th and Walnut Sts.

A charter has been granted to the Elizabeth Selig & Kauffman Pearl, Ivory and Metal Co., of Philadelphia; capital stock, \$25,000.

The unsightly platform that has surrounded the base of the metal work on the City Hall tower for many years has been removed. It is expected that by the end of September the tower, with the exception of the clock, will be completed. The matter of procuring the latter will be considered at the meeting of the Building Commission next month.

In a charge of selling goods by making false and fraudulent representations, Isaac Rosenthal has been held in \$600 bail by Magistrate Jermon. Rosenthal sold a watch to L. Laberwitz for \$15 and claimed that the case was of pure gold. The purchaser, who bought a locket at the same time, subsequently discovered, he alleges, that the watch was worth only \$4 or \$5.

**Pittsburgh.**

L. N. Marsh, Bellaire, O., has sold out his stock at auction.

M. Morganstern, with Geo. W. Biggs & Co., has patented a pneumatic bicycle brake.

Carlson & Co., formerly of Bellwood, Pa., have opened a new store at 5300 Butler St., this city.

Chas. Weinhaus, local jewelers' auctioneer, is selling out the stock of Max Rudert, McKeesport, Pa.

G. B. Barrett & Co. are busily engaged in stock taking, consequently the full force of employes are at work.

Visiting jewelers last week included: Frank Hayes, Washington, Pa.; Mr. and Mrs. John Zugschwert, Carnegie, Pa.; Harvey Morrison, Mt. Pleasant, Pa.

M. Schweitzer, western representative for M. Bonn & Co., came in last week from his latest trip covering territory as far west as Wisconsin, with a favorable trade report.

David Gray, who has been identified with the jewelry trade for the past 35 years and as watchmaker for G. B. Barrett & Co. for 20 years, has decided to enter the ranks of the benedicts and will marry a charming Williamsport girl the last of this month.

Local jewelers who are taking "vacations" are: Herman Cerf, M. Bonn & Co., at Ebensburg, Pa.; Mr. and Mrs. Charles Saunders, Cincinnati, O.; Jesse Crawford, traveler for Goddard, Hill & Co., at Atlantic City; Maurice Baer, Atlantic City; George West, West, White & Hartman, Cape May.

George Cohen, Smithfield St., was neatly flim-flamed on Saturday last. A well dressed man entered his store and asked to see some diamonds which he wished to buy as a present for a past-commander of the Knights of Pythias. He was shown a tray of loose stones, and selected two valued at \$165 each. He handed Cohen an envelope, telling him to wrap the stones in cotton and place them in the envelope. He then took out a roll of bills, counted them and found that he was short. He handed the envelope back to Cohen, displaying a \$50 check, which he said he would go and get cashed. After an half hour's wait Cohen became suspicious, opened the envelope wherein were two neat little glass stones. The wrong envelope had been returned. As usual there is no clue.

**Syracuse.**

George E. Wilkins left Saturday for a few days' business trip to New York.

H. R. Coburn returned Monday from a month's sojourn at Southold, L. I.

H. J. Howe left last Monday for a stay at Henderson Harbor, on Lake Ontario.

Maurice Rheinauer will be admitted to partnership in the Syracuse Silver Mfg. Co. on Aug. 15th. The capacity of the plant will be doubled, a large amount of new machinery put in, and several new patterns will be ready for the Fall trade.

The jewelry stock of Isaac Jacobs, Winter-set, Ia., was damaged by water during a recent fire.

## EFFECT OF FREE SILVER COINAGE UPON THE SILVERWARE INDUSTRY.

Prominent Silverware Manufacturers and Dealers Express Decided Views on the Possibility of the Election of a Free Silver President.

### SECOND SERIES OF LETTERS.

Should the possibility of the election of William J. Bryan, on a free silver platform, ultimately prove a reality, the industrial and commercial world in general would be affected to its very foundation. The silverware industry and consequently the jewelry business generally would be affected in a double sense, for they consume a large part of the silver used in the industrial arts. In order to learn how the silversmiths and jewelers feel on the subject, a letter, of which the following is a copy, was sent just after the nomination of Mr. Bryan, to a number of prominent silverware manufacturers and dealers:

New York, July 10, 1896.

Gentlemen:—We would like to publish your opinion as to the effect upon the Silverware Industry, the election of a Free Silver President would have.

The aggregation of these expressions of opinion from the entire silverware industry may be used with great effect in the campaign, for or against, depending upon the consensus of opinion.

You may make your communication as long as you desire.

Yours truly,

The Jewelers' Circular Pub. Co.

### IT WOULD INJURE THE SILVERSMITHS' CRAFT.

NEW YORK, July 15, 1896.

Editor of THE JEWELERS' CIRCULAR:

It is our opinion that the adoption of free silver coinage will have a tendency to injure our business as silversmiths, in that it cheapens the value of our productions in the eyes of the public, lessens the dignity, and lowers silver more nearly to the baser metals. Such a result would be a blow to our noble craft.

Yours truly,

GEO. W. SHIEBLER & CO.

### THE SILVERWARE INDUSTRY WOULD PROFIT.

CONCORD, N. H., July 15, 1896.

Editor of THE JEWELERS' CIRCULAR:

The election of a Free Silver President in the person of the present nominee is fraught with much uncertainty. Business will not thrive nor will capital seek investment in an atmosphere of distrust. Prosperity is not built on a single idea, but a comprehensive policy at Washington which should include ability and integrity to administer all functions of government wisely and judiciously would give impetus to business at once. It is unfortunate that the cause of Free Silver should be presented us with those Populistic assaults upon the fundamental principles of representative government.

As manufacturers we would welcome an advance in silver to its coinage value. At

that price we should expect to see the silverware interest prosperous and the output of the highest artistic merit. Every move in the past to cheapen the manufactured product has caused dissatisfaction with consumers, tradesmen and manufacturers alike. Long usage has established its position as the best obtainable metal for its present artistic and practical purpose, and as such its general use is certain to increase, but its intrinsic and heirloom value has greatly depreciated in the mad rush for low prices. A restoration to its once honored place will be gladly appreciated and the resulting effect prove a source of added strength to the silver interest everywhere.

WM. B. DURGIN.

### THE EFFECT ON THE SILVERWARE INDUSTRY WOULD BE DISASTROUS.

LYONS, N. Y., July 16th, 1896.

Editor of THE JEWELERS' CIRCULAR:

Replying to yours of July 10th, asking my opinion as to the effect the election of a Free Silver President would have upon the silverware industry. This is a question which not alone affects silverware but in my opinion the preservation of our country is at stake. Its immediate effect on the silverware industry would unquestionably be very disastrous, as we would be placed in such a position that we would not know what the value of our goods would be, and after having made sales thereof, would be still in doubt as to the value of the money received therefor.

We also feel, as far as the working men in our employ are concerned, that should we attempt to pay them with cheap money we would be robbing them of their just dues, and we also fear that it would not be long before the silverware trade with very many others would be wiped out of existence by the coinage of free silver, as it would place the business world in such a position of uncertainty and distrust as to block the natural channels of trade.

Under the administration advocating the coinage of silver at 16 to 1 there would be constant fear that after coining the cheap dollar, which would be nothing more or less than repudiation of part, it would not be long before it would be repudiation of the whole.

The silver question is one that in theory may look very enticing to the debtor, but practical demonstration would be as damaging to him as to his creditor, since the law of supply and demand would constantly cheapen the value of his possessions, and although in his opinion it might temporarily reduce his indebtedness to the extent of the reduction in value of the dollar, he would soon discover that there is no power given to individual

man or government to place a higher value upon a metal than can be obtained in the open markets of the world.

Very truly yours, F. O. THOMAS,  
Pres., Manhattan Silver Plate Co.

### WOULD NOT AFFECT THE SILVERWARE INDUSTRY PERCEPTIBLY.

NEW YORK, July 13th, 1896.

Editor of THE JEWELERS' CIRCULAR:

In response to yours of the 10th, permit us to say that in our judgment the election of a President favorable to and committed to free silver, particularly if a friendly Congress should also be elected, would be followed by a depression and distress in our business in common with other lines, unequaled since 1857. The severest burden would be borne by those depending on weekly earnings, whether clerk or workingman. In wartimes a depreciated currency immediately advanced prices of all staples, and many a man spent the earnings of a full week for a ton of coal or a barrel of flour. Then all prices advanced far beyond the ratio of any possible advance in wages, and would do so again.

We think the election of a Free Silver President a remote contingency, but should it occur, the result in our opinion will be serious to the silverware trade, both employe and employer. As to the effect of free coinage of silver on the sale of sterling silverware, apart from usual and present conditions, we do not think it will affect it perceptibly.

Yours truly,

T. G. BROWN & SONS.

P. S.—It would be pleasant for the many thousand members of the Jewelers' League and Jewelers' and Tradesmen's Co. to feel that after paying in their honest dollars for years to lay up a fund for the family when they were no longer here to work for them, that that fund would come to them in dollars worth only 53 cents each—and perhaps less.

### IT WOULD PUT SILVERWARE UP IN PRICE.

BALTIMORE, MD., July 14, 1896.

Editor of THE JEWELERS' CIRCULAR:

Your letter of July 10th received and contents carefully noted. In reply to the same would say we regret that we do not know what effect the election of a Free Silver President would have upon the silverware industry. There is no question in my mind, however, that should a Free Silver President be elected that it would have the effect of putting silver up in price. Yours very truly,

CHAS. C. STEFF, Manager,  
Baltimore Sterling Silver Co.

### SILVERWARE WOULD RISE IN PRICE AND MOVE MORE RAPIDLY.

ATLANTA, Ga., July 14, 1896.

Editor of THE JEWELERS' CIRCULAR:

Replying to your favor of the 11th inst. concerning the effect on the silverware industry to be expected as the result of the election of a Free Silver President, we think there would at first be a sharp rise in the price of silver bullion and of course of the manufactured article; and as there is usually more business

done on a rising than on a falling market there would be a temporary stimulus imparted to it; indeed, we think there will be very soon a rise in the price of silver as the result of the Chicago convention.

How long this increase in price will hold of course no one can say. If there should be a 16 to 1 free silver law passed we think the country would suffer more than from any calamity that has befallen it for many years. If that should be the case the silverware industry would then suffer along with all other lines of business. But the election of a Free Silver President does not necessarily imply the passage of a free silver law, at least as long as the proportion of the free silver men in Congress remains what it is now. And we cannot believe that the American people will so far lose their common sense as to attempt in this country alone to impart and maintain a fictitious value to an unlimited quantity of a commodity which in the open markets of the world commands only half the price they would put upon it.

Respectfully,

J. P. STEVENS & BRO.

#### MOST VIOLENT FLUCTUATIONS IN PRICES AND DISASTER.

WALLINGFORD, CONN., July 18, 1896.

Editor of THE JEWELERS' CIRCULAR:

Replying to your circular letter of the 10th inst. we have to say:

We believe that if a Free Silver President is elected probably there will also be a Free Silver Congress to support him, and enact free coinage laws. The silver men claim that free coinage would result in the advance of silver to a parity with gold on a basis of 16 to 1. No doubt some advance would occur, but long before the parity point was reached the silver of other countries would be attracted to this market and this, together with the immensely increased output of our own mines, would overload us with cheap dollars to an extent hitherto undreamed of, producing, we believe, financial disaster the magnitude of which no man can foretell.

We cannot, even with unlimited free coinage, absorb the available silver product of the world, and even a free silver Congress would finally see its folly and repeal its free coinage laws. Then would come the drop, lower than ever before, and silversmiths and merchants would face extremely low prices with a stock of goods made from bullion at a high price. Stability in prices is always desirable but we cannot see how the entrance into power of the silver party can fail of producing the most violent fluctuations in prices of all commodities and dire disaster to the business interests of the country.

Yours very truly,

R. WALLACE & SONS MFG. CO.

W. J. Leavenworth, *Treasurer.*

#### PRICES WILL SEE-SAW FOR SOME TIME.

NEW ORLEANS, July 16, 1896.

Editor of THE JEWELERS' CIRCULAR:

Your favor 13th inst., requesting opinion on "effect on Silverware Industry of election of a Free Silver President," duly received. On this subject we are very much at sea. The

first effect will be to increase the cost of silver bullion—how much we cannot say. Later the price will go down; how soon or late we do not know.

The general effect on all business will be doubt and disturbance of confidence, and consequent depression, and possible disaster. We trust we will prove to be a false prophet.

Yours truly,

A. B. GRISWOLD & Co.

#### A NATIONAL CALAMITY.

OMAHA, NEB., July 17, 1896.

Editor of THE JEWELERS' CIRCULAR;

Your favor of the 13th inst. at hand, and in reply would say that we look upon the election of a Free Silver President at the present time as a National calamity, and not only a continuation of the present depressed condition must follow, but greater distress amongst all our industries will be the inevitable result.

A speedy return to a protective tariff will give work to our idle men at the best wages paid in any country, and then the money question will be adjusted. The United States cannot give us 16 to 1 silver and gold independent of the rest of the world.

We cannot see that the silverware industry would very much differ from other lines during a general depression. But we do think that with the return of prosperity, should there be no great appreciation in the value of silver, that the silverware industry must assume greater proportions and form an increased percentage of the jewelers' total business.

Yours very truly,

A. B. HUBERMANN.

#### MOST BENEFICIAL EFFECT UPON THE SILVERWARE INDUSTRY.

DENVER, COL., July 16, 1897.

Editor of THE JEWELERS' CIRCULAR:

Yours of July 13th requesting opinions as to the effect upon silverware industry the election of a Free Silver President would have is before us.

In our humble opinion the election of a Free Silver President would have the most beneficial effect upon the silver industry. It

seems to us, as we look back, that as silver depreciated so depreciated the honor and, in many cases, the honesty of the manufacturer and dealer, and at the same time the confidence of the consumer went lower and lower with silver. Who will not concede that from the low price of silver the manufacturer down to the consumer has not suffered? Who in the trade can remember when everything in the silver line was as cheap and at the same time as shoddy as it has been in the last three years, and where is the manufacturer, dealer or consumer who does not bewail the degenerating effect the cheapness of silver has had upon everyone connected with silverware industry? When silver was high there was no need of stamping laws, there was less fraud in manufacturing, and a legitimate profit to the maker and the dealer, and better goods for the consumer. Leaving the financial question entirely out we believe that in the event of the election of a Free Silver President the silverware industry would turn to a good and healthy condition, a demand for better goods from the consumer which would be responded to from the manufacturer and dealer and the wiping out of illegitimate competitions.

Respectfully,

A. J. STARK & Co.

#### TWO TO THREE YEARS OF HARD TIMES IN THE SILVERWARE TRADE.

AURORA, ILL., July 15, 1896.

Editor of THE JEWELERS' CIRCULAR:

In reply to yours of 13th. It would have the same effect on the silverware industry that it would on all other business; this, we think, is self-evident.

In our opinion it would be very disastrous to all business; after so many years of the present standard, and with all other nations of first rank on a gold standard, a sudden change like this would cause the greatest panic in our history, from which it would take several years to recover, and as the silverware industry is generally the first to feel the effects of "hard times" and last to recover, it would mean at least two or three more years before trade would be in a normal condition.

Yours truly,

TRASK & PLAIN.



#### "PLAYING DOCTOR."

Here is another of Rogers' beautiful groups, filled with humor and life. It represents three interesting children at play, cleverly grouped, so that a most artistic effect is given without destroying the naturalness of the scene.

Price, \$9.00. Send for Catalogue. Agents wanted.

Rogers Statuette Co.,  
441 Pearl St., N. Y.

## News Gleanings.

O. H. Wright, Ithaca, N. Y., has assigned.  
Gus Abrams, optician, Baltimore, Md., has assigned.

L. C. Broyles, San Marcial, N. M., has sold out to W. H. Kremmis.

A receiver has been appointed for Kennon Mott, Brunswick, Ga.

William C. Klein, Connellsville, Ind., has moved to Elwood, Ind.

Henning Nelson has opened a jewelry store on 7th St., Rockford, Ill.

J. U. Treadwell, Pittsburgh, Kan., has sold real estate valued at \$800.

F. H. Robertson has discontinued his jewelry business in Pratt, Kan.

Max Willkow has opened a jewelry store at 225 Seneca St., Oil City, Pa.

R. C. Green & Son, Pottsville, Pa., are removing to their new building

E. Rose has made an assignment of his jewelry business in Joplin, Mo.

Frank Cross, 6 Canal St., Grand Rapids, Mich., is running an auction sale.

C. P. Christiansen has removed his jewelry store from Salina to Mercur, Utah.

Johnson Brothers have gone out of the jewelry business in Canton, S. Dak.

The business of Waldman & Chasoff, Sedalia, Mo., is now known as Jacob Waldman.

W. F. Beckmeir has purchased the jewelry and drug business of Z. L. Martin, Hubbard, Ia.

The store of Von Guitten Bros., Chatham, Ont., was partly burned out during a recent fire.

Joe Gubble has given a chattel mortgage for \$401 on his jewelry store in Cripple Creek, Col.

C. C. Beringer, Ogden, Utah, has made an assignment of his jewelry and bicycle business.

John E. Payne, Guilford, Mo., has given a chattel mortgage on his jewelry store for \$108.

The auction sale of jewelry in Somers block, Franklin Falls, N. H., has been discontinued.

J. P. Renmuir, watchmaker, Kansas City, Mo., has been sued for \$50 for unlawful detention.

N. E. Chamberlain, Great Falls, Mont., has renewed a chattel mortgage on his jewelry business for \$2,581.

W. J. Beckel has opened a new jewelry business in connection with his barber shop, in Steamboat Springs, Col.

Clarence D. Strow, of Chicago, has purchased a half interest in the jewelry business of John L. Strow, Fort Dodge, Ia.

N. S. Plank, Iowa City, Ia., has left for the east to spend his Summer vacation in Boston, New York, Providence and other cities.

In a fire in Norristown, Pa., last Sunday, the business of H. Muencenberger was damaged to the extent of \$150; no insurance.

Floyd Bassett has resigned his position in Dallas Green's jewelry store, Ft. Wayne, Ind., to engage in business at Coldwater, Mich. He has been succeeded by Frank L. Day.

J. E. Thomas, senior member of H. E. Thomas & Co., Wilmington, Del., with his wife, has just returned from the Christian Endeavor convention held in Washington, D. C., the past week.

Zora Trubo, confined in jail at Morehead, Ky., for robbing Hamilton Bros.' jewelry store of \$200 worth of watches, broke jail last week and escaped to the mountains. Trubo confessed taking the watches, and was to be removed to Owingsville, for safe keeping.

The firm of Kopsosky & Weinstein, 732 Braddock Ave., Braddock, Pa., by mutual consent have dissolved partnership, Joseph Kopsosky continuing the business at the old stand, and Jacob Weinstein retiring. All debts of Jacob Weinstein settled by J. Kopsosky.

The G. W. Meyer Jewelry Co., Chattanooga, Tenn., a few days ago received notification that they had been appointed official time inspectors for the timepieces of all employes of the Chattanooga, Romé and Columbus Railway. This firm now act in this official capacity for eight railroads entering the city.

## Queries by Circular Readers.

**NOTE.**—Questions under this department will be answered as promptly as possible. Some queries require careful investigation before a satisfactory answer can be given; hence such answers are often seemingly delayed. THE CIRCULAR desires every jeweler to take advantage of this department.

VINEMONT, July 10th, 1896.

Editor of THE JEWELERS' CIRCULAR:

I wish to find out the address of a manufacturer of perpetual calendar clocks, in Germany, England and France. Could you give me the desired information, or can you tell me how to find it out.

CHARLES W. FEICHTINGER.

**ANSWER:**—We understand that calendar clocks are not made in England nor in France; but that they are essentially an American product. French calendar clocks which have been shown in this country are not the products of any one manufacturer, but are clocks to which calendar attachments have been fitted by the agent or importer. Bawo & Dotter, 29 Barclay St., New York, and the Chas. Jacques Clock Co., 22 Cortlandt St., New York, may be able to give you more information on this subject.

CLEVELAND, O., July 15th, 1896.

Editor of THE JEWELERS' CIRCULAR:

GENTLEMEN:—Kindly give us the address of "Western Silver Metal Co." and oblige,

Yours respectfully,

THE WEBB C. BALL CO.

**ANSWER:**—We cannot place this concern. Can any of our readers?

MOBILE, ALA., July 13th, 1896.

Editor of THE JEWELERS' CIRCULAR:

Please let me know who I could likely sell a piece of ivory to. I have a piece 2 inches thick at small end and 2½ inches at the large end, 14¼ inches long and weighs 4 lbs. 10 oz. There is a crack that extends clear across the longer end and one in the small end that extends nearly across. Mr F. Thom of this city, referred me to you for information.

Truly yours,

W. O. PETTUS.

**ANSWER:**—Deitsch Bros., 7 E. 17th St., New York, and F. Grote & Co., 114 E. 14th St., New York, are makers of ivory goods and buy considerable quantities of the raw material. Perhaps you can dispose of your piece of ivory to one of these firms.

## Classes of Goods in Demand at Various Points.

### Expensive Mountings and Large Silver Pieces in Kansas City.

KANSAS CITY, Mo., July 14.—Trade has been picking up very much in Kansas City and vicinity within the last month. Several large sales have been made. One or two retailers report a good trade on diamonds and expensive mountings. Silver cups and silver sets suitable for athletic presents are having a good sale, while shirt waist sets and small novelties are holding their own with the past two months.

### Small Silver Goods and Cut Glass in Demand in Frisco.

SAN FRANCISCO, Cal., July 12.—A. I. Hall & Co. are selling large quantities of silver blouse sets in enamel, also belts and fancy buckles, which comprise a very nice grade of goods; G. Greenzweig, shirt waist sets and studs in silver; Phelps & Adams find a sale for silver novelties, scissors, tongs, etc., and have also been selling a considerable amount of cut glass, while their trade in Elgin watches is very fair; Hammersmith & Field have been selling small silver goods and wedding sets and novelties, but little is sold in gold.

### Belts, Jeweled Hat Pins and Cycle Plates in Indianapolis.

INDIANAPOLIS, Ind., July 15.—Trade continues very quiet and dealers are not looking for much improvement for a month or six weeks. Belts in all styles continue to lead sales. There has also been a demand for jeweled hat pins and sterling silver bicycle name plates.

### Silver Novelties in Demand in the Twin Cities.

MINNEAPOLIS, MINN., July 18.—The jobbing trade in the Twin Cities at the present season is rather quiet, staples being in demand only. Watches are having very little demand, sterling novelties leading; tools and material sales are constantly increasing, and prospects for Fall trade at present appear good. Collections are fair, considering the times.

### Satisfactory Sales in Summer Goods in Philadelphia, Pa.

PHILADELPHIA, July 17.—There has been an increased demand for all kinds of Summer goods the past week and for this season of the year the trade generally has shown evidence of greater stability. A few of the houses have sold large numbers of parasols, canes, belts, handbags, lace pins, side combs, garters, hair pins, and blouse sets. In numerous instances reduction sales were announced and this accounts for some of the activity. There has been a demand for some important articles but the majority of purchases have been of an ordinary kind, the aggregate sales not realizing elaborate sums. The week's trade, however, was quite satisfactory in a general way and marks the beginning of the Summer goods clearing sales. Opticians have done fairly well in the spectacles line.



# Our Traveling Representatives



Traveling representatives may consider these columns open for the publication of any news or items of interest regarding them selves or their conferees.

**M**OST of the Cincinnati houses send out some representatives this week. New goods are arriving, and the travelers are making up their stocks.

The representation of eastern traveling men in St. Louis last week has been very light. Among the few here were Mr. Platt, Foster & Bailey, and Emil Meyer and Louis Oppenheimer, representing Max Freund & Co. The travelers in Kansas City, Mo., last week were: S. P. Stanley, Meriden Silver Plate Co.; A. L. Reed, Ames Mfg. Co.; G. W. Whitney, Belknap, Johnson & Powell; H. L. Stanton for Robt. J. Hillinger; Henry Freund; E. O. Baumgarten, Pairpoint Mfg. Co.

Looking after midsummer orders in Syracuse, N. Y., the past week were noticed: Henry Freund, Henry Freund & Bro.; Wm. C. Solomon; Mr. Stern, W. & S. Blackinton; R. Thompson, Sinnock & Sherrill; Arthur Lape, Simpson, Hall, Miller & Co.

It was reported from St. Johns, N. F., that a New York commercial traveler was arrested there Saturday for attempting to smuggle \$1,000 worth of jewelry ashore from the steamer *Portis*. He had the jewelry concealed in a gripsack. The prisoner, whose name is said to be Mayers, will be vigorously prosecuted because Governor Murray is especially severe with smugglers.

Simpson, Hall, Miller & Co.'s western travelers are all out. W. F. Adams sees the largest cities and towns of the west and northwest. H. E. Vincent goes to Tennessee, larger towns of Kentucky, Cincinnati and Indiana. W. J. Rice looks after Iowa, Wisconsin, Minnesota and South Dakota. H. A. Merrill is at home in Illinois, Indiana and Kentucky. H. L. Sherman attends the wants of Ohio, Michigan and part of Wisconsin.

Traveling men visiting the Hub the past week included: Otto Wormser, A. J. Grinberg & Co.; Mr. Russell, L. Tannenbaum & Co.; Elmer Wood, Charles F. Wood & Co.; S. O. Bigney; L. Lilienthal, U. S. Diamond Cutting & Polishing Co.; George Whiting, S. E. Fisher & Co.; Henry G. Thresher, Waite, Thresher Co.; Louis Jones, R. F. Simmons & Co.; W. S. Metcalf, Plainville Stock Co.; W. G. Clark; C. C. Munn, C. Rogers & Bros.

Among the travelers to call on Philadelphia, Pa., firms the past week were: George Read, William B. Kerr & Co.; C. Granbery, Cutler & Granbery; M. Untermeyer, Keller & Untermeyer Mfg. Co.; A. Simonson, A. J. Hedges & Co.; Edward Eckfeldt, Eckfeldt & Ackley; F. L. Wood, Carter, Hastings & Howe; Mr.

Bodenheimer, Fink, Bodenheimer & Co.; John Green, J. S. Spalding & Co.; Mr. Angell, Angell & Weiss; W. Campbell, Day, Clark, & Co., and Mr. Cheney, Ludwig Nissen & Co.

Traveling men in Pittsburgh, Pa., last week were: Frank L. Wood, Carter, Hastings & Howe; J. Franklin, L. Tannenbaum & Co.; J. D. Barber, Landers, Frary & Clark; W. R. Bristol, C. Rogers & Bros., E. H. Smith, Holmes & Edwards Silver Co.; H. R. Shirley, C. Dorflinger & Sons; Eugene H. Phillips, H. L. Judd & Co.; I. R. Theise for I. M. Bernstein; Mr. Gallagher, Sinnock & Sherrill; C. H. Higbee, Potter & Buffinton; Mr. Sichel, Spier & Forsheim; J. B. Richardson, Wm. C. Greene & Co.

Aikin, Lambert & Co.'s travelers will soon take the road for their Fall trips: M. F. Thornton, in the northwest; A. S. Riley in the Middle and Western States; E. M. Childs in the south and southwest; R. W. Hunt in Pennsylvania, Delaware, New York, etc. S. N. Jenkins is at present in Chicago, and will make a trip later. H. A. Lambert will make a Fall trip in the eastern States. C. G. Megrue recently returned from a western trip. Aikin, Lambert Jewelry Co.'s travelers, D. G. Stites and C. C. Wakefield, who will also carry samples of gold pen goods manufactured by Aikin, Lambert & Co. will make their usual trips. J. C. Wakefield will make a Fall trip in New England and New York.

## Newark.

Tiffany & Co., who are building the two new factories in Tiffany's Park, formerly known as Bird's Woods, will bring the plant from New York in the Fall when the buildings are completed.

The jewelry establishment of Benjamin J. Mayo closes every Saturday at 1 P. M. during July and August. Being a pioneer in the early closing, this is the fourth year this house has closed its doors at noon on Saturdays.

Benjamin Russell, who for many years was in the jewelry business in this city, died suddenly of heart disease at 11:30 o'clock on the morning of July 11, at his home, 64 Chester

Ave. Mr. Russell formerly lived in Jersey City, where he served as a member of the Board of Aldermen. He leaves one son, George E. Russell.

A certificate of organization of the Johnson & Backus Co. was filed in the county clerk's office July 14. The incorporators are Henry Guyer and Moses J. DeWitt, of Newark; Jacob Backus, of Brooklyn, and John H. Johnson, of Bath, N. H. The objects of the company are mining, smelting, concentrating and refining gold, silver and copper. The business will be carried on in Newark, and in Lima, Callao and Casapalca, in the Republic of Peru. The capital stock is placed at \$800,000. Business will be begun on the full amount of the capital.

## Providence.

All communications for this column, addressed to P. O. Box 1093, Providence, R. I., will receive prompt attention.

William H. Draper has returned from a two months' trip in Europe.

William L. McCausland has given a real estate mortgage for \$500 on property subject to a prior mortgage of \$2,500.

Adolph Lederer, for several years with S. & B. Lederer, has left the employ of that concern to enter into partnership with his brother, Henry Lederer, the style of the concern to be Henry Lederer & Brother.

There were a number of buyers in town the past week. Among those noted were: E. A. Dayton, Omaha; James A. Pitts, Montreal; H. M. Heyman, St. Louis; M. A. Eiseman, Chicago; S. Davis, Pittsburgh; H. Marx, D. Marx & Son, St. Paul.

Mrs. H. C. Budlong, who recently died at Norwood, was the widow of Daniel G. Hunt, a manufacturing jeweler of Attleboro, Mass. She leaves three sons and one daughter; the oldest son is of the firm of S. E. Budlong & Co., manufacturing jewelers, this city, and a second is a jeweler at Chartley, Mass.

Heard Rospess, Atlanta, Ga., has given chattel mortgages amounting to \$4,473.

Only makers of "Republican League" lapel buttons.



Hard Enamel.

Republican lapel button.



McKinley button.



Free Silver lapel button, "16 to 1."



The Favorite Republican lapel button.



Hard F-namel.

Also Democratic, Populist and Prohibition Buttons.

American and Cuban Flags in hard enamel.



Lapel buttons and Scarf pins.

**WILLIAMS & PAYTON,**  
MAKERS OF JEWELRY,  
PROVIDENCE, R. I.

New York Office: 176 BROADWAY.

For Artistic, Original Campaign Buttons see our Line.

SEND FOR ILLUSTRATED CIRCULAR.

The "Little Nipper."



Lapel buttons and Scarf pins.

# \$1000

## IN PRIZES

Awarded by The Jewelers' Circular Pub. Co.



**PRIZE \$10**—For drawing and description of best Original Design for jewelry store window decoration.

**PRIZE \$5**—For Second Best.

**PRIZE \$10**—For the Photograph of the best displayed window in the jewelry trade.

**PRIZE \$5**—For Second Best.

**PRIZE \$10**—For the Photograph of the best arranged interior of a jewelry store and description of same.

**PRIZE \$5**—For Second Best.

**PRIZE \$15**—[Open only to employes] For the best essay on "How to Successfully Conduct a Jewelry Business"

**PRIZE \$5**—For Second Best.

**PRIZE \$15**—[Open to Travelers only] For the best essay on any topic he may select bearing upon the relations of the traveler to the principal and the trade at large.

**PRIZE \$10**—For the most effectively written advertisement, advertising a holiday line of the goods generally carried in a retail jewelry store.

**NOTE:**—No limit as to space ad. is to occupy.

**PRIZE \$10**—For the Best Design (drawing) for advertising a holiday stock of jewelry. **NOTE:** No limit as to space design is to occupy.

**NOTE:**—All Photos and all Mss. sent in competition, to be the property of The Jewelers' Circular Pub. Co.

**NOTE:**—All Photos and all Mss. to be in the hands of the publishers not later than Sept. 1, 1896.

**NOTE:**—A competent jury will pass upon all matter sent in in the various contests, of which notice will be given hereafter.

All matter to be sent to

**The Jewelers' Circular Pub. Co.,**  
189 Broadway, New York.

### Last Week's Arrivals.

**THE CIRCULAR** has perfected arrangements for obtaining the names and hotel addresses of all the latest buyers visiting New York, and each day posts in its office, 189 Broadway, a bulletin which every member of the trade is cordially invited to copy.

The following out-of-town dealers were registered in New York during the past week: E. A. Eisele, Buffalo, N. Y., Imperial H.; N. B. Levy, Scranton, Pa., Astor H.; L. Levy, Syracuse, N. Y., Astor H.; A. E. Paul, Boston, Mass., Marlboro H.; W. B. Musser, Lancaster, Pa., Sturtevant H.; E. R. Bennett, Amherst, Mass., Astor H.; A. L. Bearse, Boston, Mass., Murray Hill H.; W. A. Jameson, Niagara Falls, N. Y., Astor H.; W. W. Beveridge, Washington, D. C., Murray Hill H.; Thomas D. Witt (E. Jaccard Jewelry Co.), St. Louis, Mo., Murray Hill H.; M. S. Liberman, Syracuse, N. Y., Astor H.; J. Saunders, Toronto, Ont., Sturtevant H.; H. A. Kellam, Atlanta, Ga., Broadway Central H.; R. E. Burdick, Cleveland, O., Astor H.; W. F. Kemper, St. Louis, Mo., St. Cloud H.; H. Mauch, St. Louis, Mo., St. Cloud H.; A. Zerweck, St. Louis, Mo., St. Cloud H.; J. H. Bullard, St. Paul, Minn., New Amsterdam H.; F. O. Froeb, Terre Haute, Ind., Broadway Central H.; A. C. Anderson, Toronto, Ont., Astor H.; C. J. Steinau, Cincinnati, O., Savoy H.; A. La France, Elmira, N. Y., Astor H.; W. H. Traub, Detroit, Mich., Grand Union H.; R. P. Kincheloe, jewelry buyer for J. Shillito Co., Cincinnati, O., 56 Worth St.; M. Garson, jewelry buyer for Garson, Kerngood & Co., Rochester, N. Y., H. Vendome.

### Trans-Atlantic Voyagers.

#### TO EUROPE,

L. W. Rubenstein and wife, New York, sailed for Europe July 14 on the *Havel*.

M. Bauman, St. Louis, Mo., sailed for Europe July 18 on the *Campania*.

#### FROM EUROPE,

Chas. G. Rathgen, of Ferd. Bing & Co., New York, and Léon Favre, New York, arrived on *La Gascoigne*.

Herman Keck, of the Herman Keck Mfg. Co., Cincinnati, O., and Capt. R. E. Burdick, of the Bowler & Burdick Co., Cleveland, O., arrived on the *St. Paul*.

Samuel Druiff, of S. & S. Druiff, New York, arrived on the *Umbria*.

Olin H. Wright, Ithaca, N. Y., has assigned. After the assignment, but before recording, the sheriff, acting under a warrant of attachment by Judge Almy, took possession in the name of N. H. White & Co., New York, who are large creditors. It is a question whether the assignment is good without recording, in which case the sheriff is not protected; or whether recording the assignment is essential to its validity, which is the claim made by the attorney of the sheriff.

# The Jewelers' Circular

AND  
HOROLOGICAL REVIEW.

PUBLISHED EVERY WEDNESDAY BY  
**THE JEWELERS' CIRCULAR PUB'G CO.,**  
189 BROADWAY, NEW YORK CITY.

A JOURNAL DEVOTED TO THE INTERESTS OF JEWELERS, WATCHMAKERS, SILVER-SMITHS, ELECTRO-PLATE MANUFACTURERS, AND ALL ENGAGED IN KINDRED BRANCHES OF INDUSTRY.

Member of the American Trade Press Association.

Our Editorial columns will contain our own opinions only, and we shall present in other columns only what we consider of interest or value to our readers. Advertising matter will not be printed as news.

Advertising rates in THE CIRCULAR are lower, considering the number of tradesmen reached by its large circulation, than in any other jewelry journal.

Notices of changes in standing advertisements must be received one week in advance; new matter can be received up to Monday.

## INFORMATION FOR SUBSCRIBERS.

### Terms of Subscription, Postage Prepaid.

	PER ANNUM.
United States and Canada, . . . . .	\$2.00
Foreign Countries in Postal Union, . . . . .	4.00
Single Copies, . . . . .	.10

New Subscribers can commence at any time.

Payments for THE CIRCULAR when sent by mail, should be made in a Post-Office Money Order, Bank Check or Draft, or an Express Money Order or Registered Letter. All postmasters are required to register letters whenever requested to do so.

Pay money only to authorized collectors having proper credentials.

Returning Copies Returning your paper will not enable us to discontinue it, as we cannot find your name on our books unless your address is given.

Changing Address. In changing address always give the old as well as the new one. Your name cannot be found on our books unless this is done.

Discontinuances. We will continue to send papers until there is a specific order to stop, in connection with which all arrearages must be paid; but such an order can be given at any time, to take effect at or after the expiration of the subscription. All such orders will be promptly acknowledged by mail.

Liability. The Courts have decided that all subscribers to Journals are responsible until arrearages are paid in full and an order to discontinue has been received by the publisher.

### THE JEWELERS' CIRCULAR IN EUROPE.

among the Places in Europe where THE JEWELERS' CIRCULAR is on file are the following:

**LONDON**—First Ave. Hotel, Holborn, E. C.; Holborn Viaduct Hotel, Royal Hotel.

**PARIS**—Hotel de L'Athéné, Rue Scribe.

**BERLIN**—Deutsche Uhrmacher Zeitung, Jager-Strasse, 73.

**GENEVA**—Journal Suisse D'Horlogerie.

**AMSTERDAM**—Continental Club, Hotel Amstel.

**ANTWERP**—Diamond Club, Rue de Pelican.

Vol. XXXII. July 22, 1896. No. 25.

Every line of reading matter in THE JEWELERS' CIRCULAR, with the exception of the few brief extracts from exchanges, always properly credited, is written exclusively for this journal. Each issue of THE JEWELERS' CIRCULAR is copyrighted. Permission to quote is extended to other publications, if such quotations are properly credited.

## Switzerland's Watch Trade With the United States.

FROM "Commercial Relations of the United States" for 1894 and 1895, just issued by the Department of State, we are able to obtain an exhaustive review of the watch industry of Switzerland during these years. During 1894, of nickel watches, 1,427,400 pieces were exported; of silver watches, 2,357,400 pieces, and of gold watches 560,800 pieces. In each of these lines the number of pieces exported in 1894 shows an increase over the previous year as follows: Nickel watches, 93,800; silver watches, 81,900, and gold watches, 1,900. The values of the different classes of watches exported were as follows: Nickel, \$13,860,000; silver, \$32,630,000; gold, \$31,270,000; from which we note that, while the number of pieces exported was in excess of that of the previous year, the value of the total number exported in 1894 was less than that of 1893 by over \$2,000,000. There was only one increase, that in the value of nickel

As to Switzerland's trade in 1894 with the United States, we find that the exports of Swiss watches to the United States greatly decreased, namely, \$967,487 worth as against \$1,459,315 in 1893. Eugene Germain, consul at Zurich, says that this decrease was due to some extent to the circumstance that a number of Swiss manufacturers transferred their establishments to the United States. We have not been aware there has been any influx of Swiss watch manufacturers into the United States. Mr. Germain further remarks that the decrease refers mostly to values, the quantities exported having remained the same, the depreciation of silver having brought part of this decreased value. The United States supplied Switzerland in 1894 with a great many costly metal watch cases and also some good, cheap watch works.

From the "Statistical Report of the Commerce of Switzerland with Foreign Countries in 1893," which has lately been published, the following table is taken:

Articles.	Imports from the United States.		Exports to the United States.	
	Quantity.	Value.	Quantity.	Value.
<i>Clocks and Watches.</i>				
Musical boxes, clocks, etc. . . . .	quintals		2 071	196,293
Parts of watches, ready for setting . . . . .			44	57,488
Unfinished parts of watches, watches with spring motions, etc. . . . .		231	3	1,100
Nickel-case watches . . . . .	pieces	21	183,489	283,478
Silver-case watches . . . . .	do	10	109,100	256,320
Gold-case watches . . . . .	do	50	10,011	155,028
Chronometers, repeaters, etc. . . . .	do		169	20,148
Finished clock works . . . . .	do	567	186,440	376,507
Watch cases:				
Nickel . . . . .	do	194	45	84,501
Silver . . . . .	do	2	3	6,543
Gold . . . . .	do	1	8	42
<b>Total clock and watches . . . . .</b>			<b>1,812</b>	<b>1,408,240</b>

watches, namely, \$200,000. The decreases in the value of silver watches was \$1,540,000, and of gold watches, \$800,000. To sum up it may be said that while Switzerland exported 177,600 more watches in 1894 than she did in

The value of declared exports of watches and watch materials for the United States at the several consulates and agencies in Switzerland during the year ended June 30, 1894, is as follows:

1894

Cities.	Quarter ended—				Total.
	Sept. 30.	Dec. 31.	Mar. 31.	June 30.	
BASLE	260,437.11	242 183 11	185,065.05	181,923.79	\$69,609.06
BERNE	823.63	193.58		84.53	1,101.74
GENEVA	55,664.80	36,239.75	10,739.40	25,521.74	128,165.69
LA CHAUX DE FONDS	259,637.00	242,183.00	185,065.00	181,924.00	\$68,809.00
VEVEY	31,794.43	19,801.03	5,929.35	5,381.23	62,906.04
ZURICH & WINTERTHUR				330.39	330.39

1893, she received \$2,140,000 less for them. This decline in values in 1894 was ascribable to the precarious condition of the world's

The value of declared exports in these lines for the year ended June 30, 1895, was as follows:

1895.

Cities.	Quarter ended—				Total.
	Sept. 30.	Dec. 31.	Mar. 31.	June 30.	
Basle . . . . .	195,231.00	236,868.00	194,012.00	214,297.00	\$40,408.00
Berne . . . . .	107.12	1,017.35	124.10	1,243.45	2,492.02
Geneva . . . . .	22,587.00	24,520.24	7,743.04	28,539.28	83,389.56

markets, but in first order to the depression of the English trade since the advent of the crisis in 1890 and 1892 in the Argentine Republic and in Australia; also to the depreciation of values in those States having a silver standard, and to the crisis in the United States, which began in 1893, the deplorable effects of which were especially felt during the year 1894.

Taken all and all the reports above show a highly satisfactory condition of the watch industry, as far as the interests of the Swiss manufacturers are concerned, for though there has been a decrease in values, this decrease is likely to be temporary; while the increasing production will doubtless be of long life.

THE movement for the formation of an association of jobbers in American

watches, devised for the purpose of minimizing the deplorable price cutting practices now prevalent, has received a check in the adoption of the following resolution at a meeting of jobbers held last week in New York: "That it is the sense of this meeting that it is inadvisable to form a jobbers' association in American watches and watch cases." Notwithstanding this apparently final disposition of the matter, there existed an almost universal feeling that at the proper time, namely, when general industrial conditions are more promising of profitable fruition, a plan to stop the ruinous cutting of prices on watches and watch cases would meet with considerable support.

THE letters to the editor of THE JEWELERS' CIRCULAR, over the names of Robbins & Appleton and the Dueber Watch Case Mfg. Co., that have appeared in these columns during several weeks past have led us to investigate the matter to which they refer. From a complete review of the proceedings, which culminated in the discontinuance of the suits brought by the Dueber Watch Case Mfg. Co. against the manufacturers of watch movements and watch cases, we will say that we regret having published in these columns in the issue of July 8 the signed communication of the Dueber Watch Case Mfg. Co., per W. A. Moore, the closing sentence of which reflects upon the veracity of Robbins & Appleton. It is the policy of the management of THE CIRCULAR to exclude from their columns all matters derogatory to the interests of anyone unless these matters are comprehended in the field of substantiated news, or are of a nature calculated to defeat wrongful and illegitimate business operations. The communication referred to, owing to the more than customary pressure of editorial work, slipped into THE CIRCULAR columns without having bestowed upon it the careful consideration such matters usually receive.

#### Rise in the Price of Rough Diamonds.

It was reported last week that the English syndicate controlling the output of diamonds of the De Beers Consolidated Mines Co. had declared a raise in price on rough, and that consequently the price of cut diamonds here and abroad had been advanced. Among the firms in the syndicate are: L. & A. Abrahams, Joseph Bros., Weiner, Beit & Co., A. Dinkelsbueher and Bernheim, Dreyfus & Co. But few of the diamond importers and cutters in New York whom a CIRCULAR reporter saw knew anything of the reported raise.

"Yes," said Mr. Goldsmith, of Stern Bros. & Co., "there has been a slight increase in rough—62 cents per karat; it simply shows that despite the business here the market in Europe is strong. The raise went into effect July 1st."

Mr. Judels, of Kryn & Wouters Bros., Brooklyn, knew nothing about the advance.

Mr. Schiele, of Wallach & Schiele, had heard nothing of the raise. The invoice his firm had received last week on the *Campania* showed no advance. The syndicate, he explained, had been advancing the price of

rough gradually for the past two years, six pence and a shilling at a time. The 62 cents raise on rough would, he said, mean a corresponding increase in the cost of cut diamonds of between \$1.50 and \$2 per karat.

August Oppenheimer, of Oppenheimer Bros. & Veith, had not heard of the reported raise, but thought it not unlikely that rough was higher, as it had been going up for the past two years. The reported raise of 62 cents, he said, was greater than any previous raise the syndicate had attempted to enforce, and would mean an increase of nearly \$2 per karat on cut diamonds here.

S. Frankel, of Joseph Frankel's Sons, who recently returned from Europe, knew nothing of the raise in rough, but said that in the European market melee and rose diamonds had risen in price.

Randel, Baremore & Billings had not imported any rough since May; so, Mr. Mount of that firm stated, they were not aware of any recent raise nor had they been apprised of any through their brokers in Europe.

At the office of L. & M. Kahn & Co., a CIRCULAR reporter was told that they had received word from Europe of an attempt by the syndicate to raise the price of diamonds but they could give no information on the subject.

A. J. G. Hodenpyl, of Hodenpyl & Sons, had heard nothing regarding any raise of prices on rough or cut diamonds.

#### Financial Embarrassment of Refiner James B. Arnold.

PROVIDENCE, R. I., July 20.—The manufacturing jewelry circles in this vicinity were surprised this morning when it was rumored about that the long established gold and silver refiner, James B. Arnold, 226 Eddy St., was financially embarrassed. To a very few it was known about three months ago that Mr. Arnold was in financial straits, but to the majority the news came unexpectedly. At that time Mr. Arnold went to Thomas F. Arnold, of Arnold & Steere, manufacturing jewelers, 94 Point St., and secured him as endorser upon considerable of his paper. In time obligations by indorsements aggregating \$40,000 were discovered and Mr. Arnold found it impossible to obtain any further accommodations in this direction. Of this paper \$16,000 worth has been provided for, but the remainder, some \$25,000, must be met by the endorser, as J. B. Arnold has no property. It is stated that what residential property which might have been counted upon as assets was some time ago transferred and conveyed to Mrs. Arnold. The records during the past week show the transfer of a piece of real estate on Atlantic Ave., from James B. Arnold to Thomas F. Arnold for the nominal sum of \$10.

This balance of \$25,000 is being adjusted and efforts made for its being cared for, but James B. Arnold has but little to say concerning the case, except that the matter was one that concerned only himself and his endorser, and that he, James B. Arnold, had no other debts and no one else held any of his paper. The firm of Arnold & Steere is in no way affected by the endorsements.

#### New York Notes.

A judgment for \$43.27 was entered Saturday against Wyckliffe B. Durand, by Hays & Greenbaum.

A judgment against Newwitter & Rosenheim for \$1,521.01 has been filed by H. Fletcher and others.

The Geneva Optical Co., Chicago, Ill., and Rosenzweig Bros., New York, have applied for membership in the New York Jewelers' Board of Trade.

Louis Wittnauer, of the firm of A. Wittnauer, watch importers, is receiving the congratulations of his friends upon the addition of a male member to his family.

Fannie Goldstein, a 20-year-old girl, was arranged in the Essex Market Court Friday charged with stealing jewelry from William Pick, a salesman in the employ of Falkenau, Oppenheimer & Co., at 40 Maiden lane. Pick claims the robbery was accomplished December last by means of knock-out drops.

George C. Comstock Wednesday entered two judgments against Samuel E. Turner and George S. Wickham, as surviving partners of the firm of D. H. Wickham & Co., who failed, several years ago. One was for \$11,792 in favor of Adolphus Cohen, of London, and the other for \$3,728 in favor of Gustave Granischstaedter & Nephew, also of London, on accepted drafts.

Special Treasury Agent Cummings and S. Frankel, secretary of the Diamond Importers' & Cutters' Protective Association, when questioned by a CIRCULAR reporter Monday, characterized as a "fake" the story printed in several morning papers regarding the discovery by Treasury officials of a scheme to smuggle diamonds into this country by means of carrier pigeons.

In the City Court, Thursday, Judge Conlan denied a motion to vacate an order of arrest, by which Simon Harris, jeweler, was recently taken into custody. Harris is defendant in an action brought by Julia Dietz to recover \$930 for goods sold. The order of arrest was granted on the affidavit of Herman J. Dietz, the husband of the plaintiff, who alleged that on June 10 Harris bought \$930 worth of diamonds from Mrs. Dietz, and then disposed of his property with intent to defraud creditors.

The appearance of two passengers on the *Augusta Victoria*, which arrived Saturday, aroused the suspicion of Special Inspectors Brown and Donohue, who searched them upon landing. The passengers were Robert C. Pauly, of Chicago, and Louis Cohen, of Hempstead, L. I. Pauly had in his overcoat pocket a man's gold watch and chain, a plain gold ring, a gold bracelet, two diamond rings, two diamond scarf pins and a souvenir spoon which he had not declared. In Cohen's pockets were ten diamond rings, three gold brooches and a diamond stud. All the jewelry was seized and will be sold at auction. add Trav. Rep.

Howell & Davis have succeeded to the jewelry business of Jos. Davis, Cripple Creek, Col.

## Special Notices.

Rates 75c. per insertion for notices not exceeding 3 lines (25 words); additional words 2 cents each. If answers are to be forwarded, postage stamps must be enclosed. Two insertions, 15 per cent. off three insertions, 20 per cent. off; four insertions or more, 25 per cent. off. Payable strictly in advance. Display cards on this page will be charged at \$2.00 per inch for first insertion, subject to same discount as above for subsequent insertions.

Under the heading of **Situations Wanted** on this page advertisements will be inserted for **One Cent a Word** each insertion, no discount. This offer refers to **Situations Wanted only**. Payable strictly in advance. If answers are to be forwarded, postage must be enclosed.

## Situations Wanted.

Notices under this heading **ONLY** are charged at one cent a word, payable strictly in advance. If answer are to be forwarded, postage must be enclosed.

A **YOUNG MAN**, aged 23, desires a position as watchmaker and plain engraver; good salesman. Address M., 10 Ralph Ave., Brooklyn, N. Y.

**WANTED.**—Situation by a first-class jewelry jobber, diamond setter, fine clock repairer and good engraver; south or west preferred; first-class references. Address Charles W. Stegman, 174 Dodge St., Cleveland, Ohio.

## Help Wanted.

**EXCELLENT OPPORTUNITY** for young man to finish trade. Address, with full particulars, Improver, care **JEWELERS' CIRCULAR**.

**WANTED.**—A first-class watchmaker; one having his own tools. Address, with references, stating salary expected, Brooklyn, care **JEWELERS' CIRCULAR**.

**WANTED.**—Experienced traveling salesman to handle best American line of spectacles through New York State and the East. Address Optics, care **JEWELERS' CIRCULAR**.

**WANTED.**—Experienced salesman to sell a fine line of solid gold stone rings on commission, to retail trade in New York and vicinity. Address O. M. C., care **JEWELERS' CIRCULAR**.

**WANTED.**—A salesman with established retail trade in New York, New Jersey, Pennsylvania and Ohio, to represent a manufacturer's line of high grade rolled plate chains, as a side line on commission. Address Lock Box 561, Attleboro, Mass.

## Business Opportunities.

**FOR SALE** in Philadelphia, a desirable business in a fine locality; clean stock about \$8,000, which can be reduced if desired; walnut fixtures, fine regulator, safes, etc.; good run of work; established 12 years. Address O. E., care **JEWELERS' CIRCULAR**.

**\$650.00 SPOT CASH** buys fixtures, material and optical goods of leading jewelry and optical store; established 15 years; western New York; bench work \$1,500 per year; only optician; will sell any other part of stock if desired. Address J. O., care **JEWELERS' CIRCULAR**.

## FOR RENT.

Large Office, **Corbin Building.**  
5th Floor - -

Will let very low for  
Three Years.

APPLY, - - - -

**JOSEPH FAHYS & CO.,**  
NO. 54 MAIDEN LANE, N. Y.

## AUCTION SALE. . .

MONDAY, JULY 27th,

Of the balance of Whitford's & Lindsay's stock of Silverware, etc. About 300 doz. Rogers and Reed & Barton knives, forks, spoons, etc., to be sold in lots of 5 or 10 doz.; also some Jewelry and Regulator, Gas Fixtures, Geneva Glasses in case, lot of Material, Lathe, Safe, Jewelry and Silverware Boxes, and black walnut Plate Glass Showcases and Counters and Wall Cases that cost \$5,000.

**J. P. HALL, Auctioneer,**  
421 Washington St., Boston

SALE POSITIVE.

## Gold Foxtail Solid Link Chain

FOR THE TRADE

Now made right here in this country, all by machine. From ½ dwt. to 6 dwt. per foot, add 50 cents making to the weight for cash.

There is no Jeweler who will not use the chain.

**E. ROEDIGER,**

MANUFACTURER,

Near Providence.

PAWTUXET, R. I.

## Workshop Notes.

200 PAGES BOUND IN CLOTH.

The most complete book of the kind ever published.

A perfect encyclopedia of information.

With a copy of Workshop Notes and 52 numbers of **The Jewelers' Circular** (a year's subscription price, \$2.00), any jeweler will have all the trade literature he needs.

SEND \$2.50 AND GET BOTH.

## WHAT THE JEWELERS' CIRCULAR CONTAINS and DOES.

- Matters in Jewelry Store Keeping** { Makes your show windows a source of direct profit.  
Makes your store a regular commercial enterprise.  
Causes your business to be better known to your public.  
Keeps your business bright and up-to-date.
- Optical Department** { Perfects you in your knowledge of optics.  
Keeps you posted in new optical appliances.  
Tells you how to make your optical dept. profitable
- The Connoisseur** { Looks after your art goods department.  
Informs you as to the latest products in china, pottery, cut glass and metal goods, etc.  
Makes your experiment a success.
- Workshop Notes and Technical Articles** { Posts you as to methods for doing all repairing jobs.  
Perfects you in your knowledge of Horology.  
Perfects you in your knowledge of jewelry making and repairing.  
Perfects you in your knowledge of watch repairing.
- Elsie Bee's Fashions** { Tells you the leading fashions in Jewelry, etc.  
Tells you what to buy and what to avoid.  
Tells you what is salable and what is not.  
Tells you what will be fashionable.
- News Gossip Editorials** { Saves you from thieves by disclosing their tricks.  
Saves you from burglars by showing the vulnerable points of a jewelry store.  
Captures Malefactors for you by spreading accurate descriptions of them.  
Saves you from failure by showing you why others fail.  
Saves you from legal troubles by defining new laws.  
Saves you from injudicious purchasing by telling you the fashions, state of trade, etc.
- Advice and Criticism Retail Advertising** { Makes your newspaper advertising pay.  
Teaches you in Pamphleteering.  
Saves you money in your advertising account.  
Eases the burden of advertisement writing.

BUYERS' INFORMATION BUREAU.

QUERIES BY CIRCULAR READERS.

WORLD OF INVENTION.

All for **\$2.00** a Year.

All for **4 CENTS** a Week.

THE BEST OF THE EMPIRE WESTWARD TAKES ITS WAY!

# WESTERN SUPPLEMENT

## of THE JEWELERS' CIRCULAR

VOL. XXXII.

CHICAGO, WEDNESDAY, JULY 22. 1896.

No. 25.

### Chicago Notes.

All communications in reference to the Chicago department of *The Jewelers' Circular*, addressed to S. Parlin, 270 Garfield Ave., Chicago, will receive immediate attention.

Elmer A. Rich, of Rich & Allen Co., goes east this week.

M. Morris, St. Louis, was seen on Chicago streets last week.

J. R. Davidson, J. Muhr & Bro., left Tuesday on a general western trip.

Simon Glichauf, Glichauf & Newhouse, has gone to Spring Lake, Mich., for a rest.

George D. Lunt, Towle Mfg. Co., has returned from a visit to his mother at Newburyport, Mass.

Walter Ghislin, Gorham Mfg. Co., is vacationing with his family in the vicinity of Gray's Lake, Ill.

Sam Bauman, of the Bauman-Massa Jewelry Co., St. Louis, passed through on his way to meet his family at Elkhart Lake, Wis.

President L. D. Cole, of the Towle Mfg. Co., is on what will probably be extended into a two weeks' visit with the Chicago house.

Geo. W. Harder, representing Osborn & Co., manufacturers of silver plated ware and novelties, Lancaster, Pa., was in town last week.

The only feature of trade the past week was the exodus of travelers from jobbing houses to their respective territories. Sales were light and outside buyers few. Collections dull.

Goldsmith Bros., refiners, confirm the opinion that these are good times for a jeweler to gather up and realize on old stock. Shipments of old gold from jewelers, they report, "keep up first rate."

H. D. Parkes, buyer for Lapp & Flershem, has rented a cottage for six weeks at Paw Paw Lake, Mich., and the family will pass the heated term at that resort. Mr. Parkes will return after two weeks.

"Collections are worse than I have ever before seen them," said a leading credit man. "Either there is no money in the city or else everyone is holding on to it. We have numerous requests from small dealers for renewals of notes."

Messrs. Stanley and Fowler, of Walton, Stanley & Fowler, have gone on the road, Mr. Stanley taking the field west of the Mississippi, and Mr. Fowler the States of Michigan, Wisconsin, Indiana and Illinois.

"Mr. Gallagher, for Sincock & Sherrill, was the only real live man in town last week," said a prominent buyer for a jobbing house, but this was said before the arrival of Mr. Platt, Foster & Bailey's man, who came in Friday.

The many friends of C. E. Taylor, in charge of the hotel department of the Gorham Mfg. Co., were deeply grieved to hear of the death of his wife. Mrs. Taylor died July 10th at their home, 1226 Jackson St., after an illness of six weeks. Death came unexpectedly from a different cause—apoplexy.

A. C. Becken & Co. have in preparation a catalogue for 1897 that contains some new features of special interest to the trade, but which they desire withheld from criticism until the book is placed in the hands of the trade. A special room has been engaged for the preparation of the work and everything that skill and experience can suggest has been brought to bear to make the book the most complete of all ever issued by the house. It is promised to the trade in ample time for Fall buying.

A very handsome line of hollow ware was received Friday from the factory at the Manhattan Silver Plate Co.'s Chicago salesroom. The new line is the largest assortment received in one shipment. In salts and peppers, 11 different patterns are shown, each new in design. Cake baskets, candelabra, nut bowls, smoking sets, puff boxes, tea and dessert sets, fern dishes, bon bons, trays, etc., are shown, and the line is an excellent one to push forward the company's Fall business.

### St. Louis.

J. M. Steideman, of J. W. Cary & Co., who has been ill for the past month is considerably improved.

A. R. Brooks is getting out a special catalogue, devoted to optical goods.

E. H. Pelton, secretary of the Pelton Bros. Silver Plate Co., is on an eastern trip. At present he is in Albany, N. Y.

Morris Bauman, of L. Bauman Jewelry Co., arrived home from New York, Monday. Meyer Bauman, of the same firm, is still in the east.

Geo. H. Kettmann & Co., formerly of Louisville, Ky., have opened a watchmakers' supply establishment at 106 N. 6th St., this city.

S. H. Bauman, of the Bauman-Massa Jewelers' Supply Co., arrived home on the 18th after a pleasant vacation spent at Elkhart Lake, Wis.

The St. Louis Silver Co. and the Pelton Bros. Silver Plate Co. have again started up their factories after an idleness of several weeks' duration.

All of the traveling men of the local jobbing concerns are getting their trunks in order, and will leave at an early date, for their respective fields of labor.

The local contingent to the convention at Atlantic City got off in good shape, and were not forgotten by their St. Louis friends. The Barbour Silver Co. and the Holmes & Edwards Silver Co. presented them two jars: one labeled "Silver Plated" and the other "Quadruple Plated." It is said the contents came from the Vuelta Abajo district of Cuba.

### Pacific Coast Notes.

The jewelry store belonging to the estate of J. E. Southworth, Santa Clara, Cal., has been sold.

Hal Sanders has opened a jewelry establishment in Cayucos, Cal. He will also conduct a bicycle repair shop.

M. German, who has conducted a jewelry store in Prescott, Ariz., for a short time, has left for Jerome, Ariz.

J. J. Wilson, who is in both the jewelry and saloon business in Roseburg, Ore., has given a chattel mortgage on the saloon fixtures for \$170.

E. J. Swaner, of the jewelry firm of E. J. Swaner & Co., Salt Lake City, Utah, has had judgment entered against him, on account of past real estate deals.



**ASK YOUR JOBBER FOR  
S. O. BIGNEY & CO.'S HIGH  
GRADE**

# CHAINS

**THEY EQUAL SOLID GOLD IN STYLE AND FINISH.**

NOTE TRADE-MARK.

**Detroit.**

H. W. Battie, of Cleveland, is in the city taking a course in optics.

L. Black & Co. last week removed into new quarters at 154 Woodward Ave.

Edward Roehm, of Rhoem & Son, is at New Baltimore, Mich., with his family.

Frank Mathauer, with H. Koester & Co., is spending a 10 days' vacation on the lakes.

W. A. Sturgeon, of Smith, Sturgeon & Co., has returned from a trip up the St. Lawrence river, with his family. North Wilcox, of the same firm, is away on his vacation.

The following Michigan country jewelers were in Detroit last week purchasing goods: M. D. Walton, Armada; C. E. Spencer, Cass City; G. W. Stevens, Port Huron; P. W. Doley, Northville, and S. A. Cleveland, Utica.

The dull midsummer season is on here and business with the jewelers is very quiet. Many of the clerks are away on vacations, and no traveling men were seen last week. The A. O. H. convention held here last week brought considerable trade to the city, and the jewelers report a temporary jump in sales.

**Indianapolis.**

John Gardner made his first trip last week for the new wholesale house of Gardner & Ross.

The Columbian Jewelry Co., Louis Haas, manager, have removed from N. Illinois St. to 17 S. Meridian St.

J. S. Platt, Foster & Bailey; Ernest Block, W. & S. Blackinton; Daniel Wile, Buffalo Jewelry Case Co., were in Indianapolis, Ind., last week.

Last week Baldwin, Miller & Co. collected damages from the Evansville & Indianapolis R. R. Co. for injury done to a trunk carried by their Indiana traveler, Oscar Dearing. In unloading the baggage at Oakland City, Ind., the trunk was hurled under the car to the damage of both trunk and contents.

**Kansas City.**

W. S. Willard has opened a new jewelry store in Olathe, Kan.

J. C. Shobo, Ottawa, Kan., and his son were visiting in town all last week.

L. P. Ilkenhaus has remodeled his store at 627 Kansas Ave., Kansas City, Kan.

M. Benjamin left last week for an extended business trip through Kansas and Colorado.

C. H. Wells, traveler for Woodstock, Hoefler & Co., in the north, was in town last week and will remain for a short time.

M. Edwards, of Edwards & Sloane Jewelry Co., and C. E. Hoefler, of Woodstock, Hoefler & Co., have returned from Chicago.

D. Filken tein, jeweler and optician, has removed from 8 E. 12th St. to 67 James St., Kansas City, Kan., where he has a very good location for the Kansas side of town.

Among the out-of-town buyers here last week were: Gus Lyons, Ottawa, Kan.; J. I. South, Leavenworth, Kan.; J. H. Van Voorhes, Carthage, Mo.; W. H. Rhoades, Liberty, Mo.

L. Megede, Richmond, Mo., held a very successful auction last week. C. W. Bouman was in charge of the sale. Mr. Megede will continue in business at the same location after his surplus stock is reduced.

**Minneapolis and St. Paul.**

C. Weding's jewelry store, 1411 Washington Ave. S., Minneapolis, was damaged by fire a few days ago to the extent of \$500. The fire started in a vacant store adjoining Mr. Weding's.

Chief of Police Higgins, of Eau Claire, Wis., was in Minneapolis last week and located a lot of watches stolen from A. P. Wilder's store, Eau Claire, a short time ago. The burglars secured about \$500 worth of watches and jewelry from Mr. Wilder's store.

Otto Puhl, of Howark Lake, and his bride-to-be, arrived in St. Paul last week to purchase some wedding jewelry. They were attracted into the jewelry store of F. Shapiro, on Jackson St., and were waited upon by the clerk, V. Fink, who sold them a lot of jewelry. The jewelry turned out to be of the rankest brass. Fink was arrested, and the wedding will be postponed for several weeks, as the couple will remain in the saintly city to appear against the prisoner.

**Cleveland, O.**

W. R. Sigler has been detained at his home for a few days on account of illness.

E. R. Holter, Oberlin, who recently returned from Europe, was in this city last week.

S. H. Goldsoll, a Superior St. jeweler, was arrested Wednesday afternoon on a warrant charging him with assault and battery on J. H. Blackburn, who is in the picture business in the New England building. A month ago Blackburn bought a gold plated watch at an auction sale at Goldsoll's store for \$7. Blackburn alleges that Goldsoll guaranteed that the gold plate would not tarnish for three years, but that it became tarnished in 24

hours. He therefore sued Goldsoll in Justice Hutchins' court and was awarded a judgment for \$7, the price paid for the watch. To all his friends Blackburn told the story of his transactions with Goldsoll. Tuesday afternoon Blackburn and a friend were talking in a hallway near Goldsoll's store. Blackburn claims that Goldsoll rushed out of his store and struck him in the face with a pair of brass knuckles. A warrant was then sworn out for Goldsoll's arrest.

An Indianapolis girl tells of a horrible dream she had the other night. She dreamt there were burglars in the room and that they were carrying off her beautiful little jeweled watch. She awoke with a terrible start, lighted the gas and looked to see if her dream was true. She found that the watch was not gone, but going.



**ELGIN KING**  
**\$100.00 BICYCLES**  
 ARE  
**SWIFT, STRONG,**  
**LIGHT AND HANDSOME.**  
 None better in any respect  
 Write for Catalogue and Agents' Terms.  
 Send 10 Cents for Elgin King Scarf Pin.  
 Address Department B,  
**ELGIN CYCLE CO.,**  
 ELGIN, ILL.

NEVER BLOTS ADJUSTABLE ALWAYS READY.



**The Whitney Adjustable Fountain Pen.**  
 The only pen made using adjustable feed to regulate the flow of ink.  
**EVERY PEN GUARANTEED**  
 and money refunded if not satisfactory. Retail from \$1.75 to \$5.00. Write for catalogue and discounts to dealers.  
**R. W. WHITNEY, 236 SUPERIOR ST., CLEVELAND, O.**

**PARSONS & SCHOOL**  
 —FOR—  
**WATCHMAKERS,**  
 PEORIA, ILL  
 Send for Circular and Terms,  
**PARSONS & CO.**

EST. 1870. DR. PETER HENRY, SPECIALIST IN Watch Case Diseases



Key Winders changed to Stem Winders  
 Hunting Case changed to O.s  
 English Case changed to fit American movements  
 Can be cured at  
**53 LONGWORTH ST.,**  
 Cincinnati, Ohio.

**STERLING SILVER TABLE WARE.**

JEWELERS ONLY.



RUSTIC ALMOND SCOOP.

**TOWLE** MANUFACTURING COMPANY,

CHICAGO.

NEWBURYPORT, MASS.

The Latest Patents.

ISSUE OF JULY 14, 1896.

**563,745. DEVICE FOR DETERMINING OPTICAL AXES AND CENTERS OF LENSES.** HARRISON COLE, Columbus, Ohio.—Filed Aug. 16, 1894. Serial No. 520,535. (No model.)

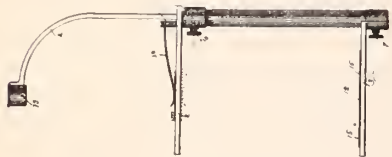

In a device for determining the optical axes and centers of lenses, the combination with a transparent stage having a central line across its face, of a protractor arranged beneath said stage and crossed lines upon the face of the protractor plate.

**563,768. BUTTON FOR CUFFS.** CHARLES HOLMAN, New York, N. Y.—Filed June 18, 1895. Serial No. 553,195. (No model.)



A button for cuffs and the like, the same comprising a head and a foot, the head being hollow and the under side of the head having a central aperture and a screw-threaded boss surrounding the same, and links attached centrally to the inside of said head through said aperture and to said foot and connecting the same loosely, the links being adapted to be received wholly within the hollow head through the aperture in the under side of said head, and the said foot having a screw-threaded shank to engage said boss.

**563,777. STEM WINDING AND SETTING WATCH.** GEORGE A. LOCKWOOD and JAMES E. LOCKWOOD, Chariton, Iowa.—Filed July 3, 1895. Serial No. 554,870. (No model.)

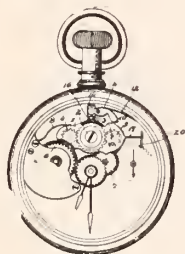

In a watch setting mechanism, the combination with the yoke and the winding and setting train carried thereby, of the longitudinally-movable winding-stem, means interposed between the stem and yoke for oscillating the latter, and a spring finger integral with and carried by said yoke and adapted to engage one of the wheels of the movement simultaneously with the throwing of the setting-train on the yoke into engagement with the setting-wheel.

**564,882. LOCKING DEVICE.** ISADOR B. RAPAPORT, Chicago, Ill. Filed Jan. 8, 1896.—Serial No. 574,684. No model.

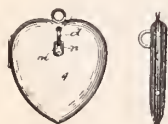

In a locking device, the combination of a casing, a hook-pin lying and rotating entirely without said casing, a shank lying and rotating entirely within said casing, said pin and shank being rotatable at their

their juncture about an axis lying within said casing, and a movable plate within said casing adapted to cover the shank portion of said pin, whereby the same is locked into position.

**563,883. ELECTRICAL PROGRAM CLOCK.** ANDREW J. KEAMS, Chicago, Ill., assignor to the Program Clock Company, of Illinois. Filed Nov. 20, 1895.—Serial No. 569,547. No model.

**564,072. TIME INDICATOR AND REGISTER.** JAMES M. HELFENSTEIN, New York, and WILLIAM K. HOLMES, Brooklyn, N. Y. Filed June 1, 1895. Serial No. 551,383. (No model.)

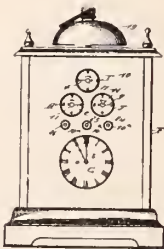

The combination, with a casing having a clock-dial on its face and a clock mechanism within the casing, of a series of time indicating dials above said clock-dial, an index-hand coacting with each time indicating dial, an alarm to be sounded when the time expires for which the indicating devices are set, gear connection between the indicating devices and clock mechanism whereby the indicating devices are simultaneously operated, and a registering device operated with the indicating devices.

**564,145. INSTRUMENT FOR DETERMINING ERRORS OF REFRACTION IN EYES.** ALFRED CLARKE, Sydney, New South Wales. Filed Oct. 19, 1895. Serial No. 565,243. (No model.)

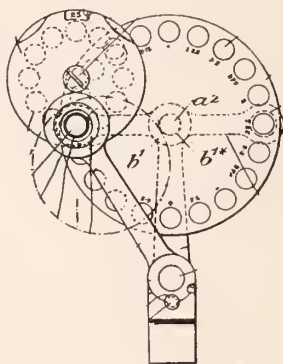

In an instrument of the character herein referred to the combination of a T-shaped stand, and a radius arm having one end pivotally mounted upon the stand so that its other and outer end is adapted to be moved in an arc from one extremity of the horizontal limbs of the T to the other extremity thereof.

DESIGN 25,767. BADGE. JOSEPH FRANKLIN

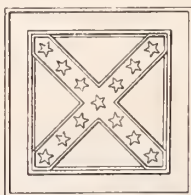

SHIPP, Chattanooga, Tenn. Filed Oct. 18, 1895. Serial No. 566,166. Term of patent 7 years.

DESIGN 25,768. BUTTON. GUSTAVUS A. SCHLECH-



TER, Reading, Pa. Filed May 4, 1896. Serial No. 590,234. Term of patent 7 years.

DESIGN 25,769. SILVERSMITH'S STOCK ORNAMENT. PHILIP MURR, Philadelphia, Pa.



Filed May 23, 1896. Serial No. 592,882. Term of patent 3 1/2 years.

DESIGN 25,770. BELT-PIN. BERNARD RICE, New



York, N. Y. Filed May 23, 1896. Serial No. 593,512. Term of patent 3 1/2 years.

Cincinnati.

Fox Bros. & Co. are mounting some beautiful diamond ornaments which the "boys" will take out with them on their trips in a few weeks.

Among the pretty new things the Homan Co. are getting out this season are the clover decorated salvers in several sizes, with the inscription "May You Always Live in Clover."

"The new initial cases of the Wadsworth Watch Case Co. are catching on," says Harry Walton, who goes out on a short trip this week with a full line. The initial may be either raised ornamented gold or diamond mounted.

Isa Schroder has returned from Long Branch, and is getting ready for the road. A. Herman has been to Mt. Clemmes and other lake resorts. L. Gutman is still in the northern part of the State. Chas. Stern has returned from the lakes.

Fred. Pieper, Covington, has returned from Atlantic City, where he went as a delegate from the Ohio Association to attend the National Retail Jewelers' Association convention. Mr. Pieper is prepared to make his report to the association when they convene.

Among the returned tourists who spent their vacations away from Cincinnati are: C. J. F. Bene, of Bene, Lindenberg & Co., who was at Narraganset Pier, and while east visited Attleboro, Providence and other manufacturing centers. Mr. Sommers, of the same firm, has returned from French Lick Springs, much improved in health.

The O. E. Bell Co. are making chatelaine pocketbooks with a handkerchief pocket in the back and with a small manicure set sterling mounted, fastened in slots back of the kerchief. The whole is the size of the bicycle pocketbook. It is suspended with a silver chain from a silver pin and may be attached to any part of the dress.

A. G. Schwab & Bro. received the other day a postal card with an order on it which was sent Dec. 14, 1888, by L. F. Jeanmaire, McMinnville, Tenn. It was found in the distributing case of a postal car where it had been pushed in a crevice and lain for the past eight years. Mr. Jeanmaire has been dead six years, and the receipt of this postal was like hearing from the dead.



DEPARTMENT OF  
ADVICE AND CRITICISM  
ON  
RETAIL JEWELERS' ADVERTISING.

[This department is free to every retail jeweler and optician. Forward for criticism your newspaper ads., booklets, catalogues, novelties, circulars, etc. Ask advice and offer suggestions. Replies in these columns are unbiased. Make letters as full and particular as desirable. Every letter and ad. sent will receive full attention, though the publication of the matter may sometimes be delayed a week or two. Address all letters and other matters to The Jewelers' Circular Pub. Co., 189 Broadway, New York.]

PART XXI.

THE advertisement of the J. E. Ellis Co., Ltd., Toronto, Can., reproduced below, is a fine jewelers' advertisement. It may not have brought as great direct returns as a bargain ad. would, but of indirect returns the quantity was enormous. And it is opportune to say here that it is not always the prime object of an advertisement that a few immediate sales should be made through it. The advertisement of the Ellis Co. is a sound and logical

If jewelers more often specifically advertised engagement rings, matrimony would be a more common institution than it is. It is not unreasonable to assert that the number of persons who meditate upon engagement when they read such an ad. is not inconsiderable, and meditation often leads to fulfillment. And if people become engaged, the jeweler profits to some extent. This syllogism might strike some jewelers as being fanciful, but

advertisers.

man always loves the jewelry store where he bought his engagement ring, and will patronize it for other needs. Altogether the ad. is A1. The engraving is a little at fault, although the design is excellent. The design is attractive, striking and reflective of the brilliancy of the goods handled by the

\* \* \*

Reproduced here is a type signature used for several years by Spaulding & Co., Chicago, Ill. It is in imitation of the old hand-cut wood type of Faust's, Gutenberg's and Caxton's time, and carries back the mind to the early days of printing. Such days-of-yore methods in advertising appeal to a large number of the people who

"——— pooh-pooh,  
Whatever is fresh and new  
And declare it crude and mean,  
For art stopped short  
In the cultivated court  
Of the Empress Josephine,"

as Gilbert puts it. This style is particularly effective in ads. representing an ancient craft as the silversmiths'.

\* \* \*

The ad. of S. K. Zook, Lancaster, Pa., which in the original occupied 4 inches single

Established in 1836.

### The Love of Diamonds

is the love of one of the most beautiful and wonderful things in nature. To love diamonds is to pay tribute to one of the works of the Creator. In many countries diamonds have been called the "Tear drops of angels," and have been enshrined in the temples of worship, and always adorned the breastplate of the high priests. The wealth of royal families is reposed in diamonds and other stones in preference to securities and bonds.

In the highest civilized nations diamonds are the symbols of wealth and the badge of aristocracy. Upon full dress occasions the costume of a lady is deemed quite incomplete without the brilliant presence of these most precious of precious stones. A giver of a diamond is never forgotten. They are the most lasting present that can be bestowed.

We make a specialty of **ENGAGEMENT RINGS**. Nothing can be too pretty or dainty for this purpose. We have the finest Diamonds that money can procure in Canada. We have all sizes, and the price being as low as from \$5.00 up.

**The J. E. Ellis Co., Ltd.,** 3 King Street, East,  
TORONTO.



argumentative reply to the fool fashion articles that appear from time to time in the daily prints. Moreover, it is interesting, and once the reader begins to read it, he or she will finish reading it, and he or she will be impressed with the truth of its assertions. It cannot be too often impressed upon the public mind that "diamonds are the most lasting present that can be bestowed;" that "a giver of a diamond is never forgotten;" that "in the highest civilized nations diamonds are the symbols of wealth and the badge of aristocracy;" that "upon full dress occasions the costume of a lady is deemed quite incomplete without the brilliant presence of these most precious of precious stones." These are truths, and should be repeated often and often by the jewelers to serve as a check to the pernicious emanations of penny-a-line fashion writers who fall back upon "jewelry is a relic of barbarism," when they have nothing else to say. The love of diamonds is universal among the people, with the exception, mayhap, of the Quakers, Shakers and Seventh Day Adventists. But these people are in the smallest sort of minority. The closing paragraph of the ad. is especially good and effective. It specifies a single class of goods, a class of goods of the broadest interest.

it is not so. Let us consider the subject. Suppose Reginald Van Puyster is contemplating matrimony with Guinevere de Dusenbury. He had not yet popped the question. Various obstacles stand in the way of his doing so. Is it altogether improbable that one of these obstacles is the cost of an engagement ring? In his dim knowledge of the value of things he thinks an engagement ring is a costly affair, far beyond his present means. When he sees that he can buy an engagement ring for \$5 he wonders why he has been so slow in pressing his suit. Suppose he doesn't care to give so cheap an affair. Then he infers that if one can get an

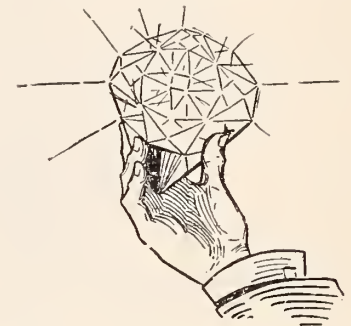

A BRILLIANT example of what can be offered in good goods at a low price is our Diamond Rings. 75c. upwards, genuine stones and solid gold.

**ZOOK'S JEWELRY STORE,**  
101 NORTH QUEEN STREET.

column, is the type of jewelers' advertising which is to be condemned. The writer is a hearty believer in the virtues of chic, unique, and original illustrations; but in the ad. the

# SPAULDING & Co.

engagement ring of some character for \$5, undoubtedly he can get a good one for \$25 or \$50, which he considers is not an altogether unobtainable sum.

It is a good point for the jeweler to claim that he makes a specialty of something; and the engagement ring is one of the best of specialties. If J. E. Ellis Co. win the reputation of being special purveyors of engagement rings, they will have gained a great point. The

illustration must be accompanied by reading matter that will draw people to the store. The cut in this ad. is not bad. Why did not Mr. Zook say under it: "scarf-pins, original designs, representing all sports, fads, games, hobbies, \$2.25 each" or "Engagement rings? Yes; we make a specialty of them—\$5 up;" or "A nice, pretty, lasting emblem of love for your daughter, for her birthday—a diamond ring—\$5 up."

# The "Safety Case" FOR Riding Specs.

## SOMETHING NEW . . . .

THIS INGENUOUSLY MADE CASE FILLS A LONG FELT WANT. IT IS STRONG, COMPACT, DURABLE AND CONVENIENT.

Ask Your Jobber for Them.

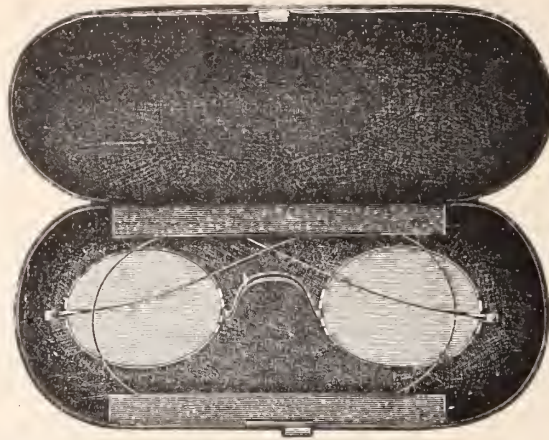

(PATENT APPLIED FOR.)

OUR REGULAR "SAFETY CASE," OF SIMILAR PATTERN, BUT SMALLER, IS THE BEST CASE EVER MADE FOR FRAMELESS, OFFSET EYEGLASSES.

For Sale by all Jobbers

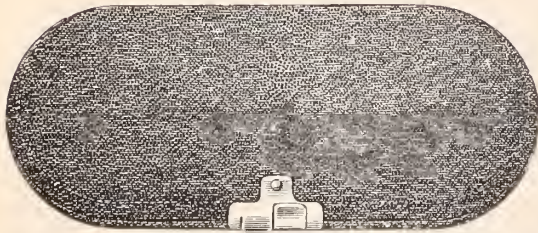

## SUSSFELD, LORSCH & CO.,

37 and 39 Maiden Lane, N. Y.

## THE SPENCER OPTICAL INSTITUTE

OUR STUDENTS ARE THE SUCCESSFUL OPTICIANS.

OUR COURSE.

PRACTICAL,  
COMPREHENSIVE,  
NON-CLASSICAL.



YOUR GAIN.

KNOWLEDGE,  
PRACTICE,  
WEALTH.

SPENCER OPTICAL MANUFACTURING CO., 15 Maiden Lane, N. Y.

Made by Merritt, Caspell & Co. Springfield, Mass.

**COMFORT AND SECURITY**  
ARE COMBINED IN MERRITT'S PATENT EYE GLASS HOLDERS.

GOODS ON APPROVAL.  
CORRESPONDENCE SOLICITED.

WHITE'S EYE SHADE.

**W. B. WHITE & SON,**  
90 South St., Boston,  
MANUFACTURERS OF  
**Spectacle and Eye-Glass Cases.**

White's Adjustable Eye Shades and Specialties in Fancy Leather Goods, Etc.  
LARGE STOCK OF CASES ALWAYS ON HAND.

## Fox & Stendicke,

Manufacturing Opticians,  
61 Fulton St., New York.  
Javal, Schiötz Ophthalmometers, Phorometers, Skiascopic Apparatus, etc., etc.

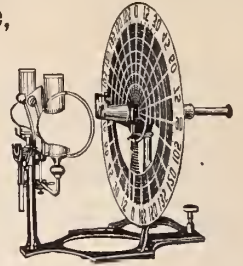

Send for Price List.

FOR RELIABLE OPTICAL WORK

SEND TO

JOS. FRIEDLANDER & BRO.,  
OPTICAL LENS GRINDERS,  
9 MAIDEN LANE, - - - NEW YORK.

SEND FOR DESCRIPTIVE CIRCULAR OF OUR FRAME AND LENS CABINET.

## Optical Books.

Any book pertaining to the subject of ophthalmology can be obtained through the Jewelers' Circular Publishing Company. Send for new catalogue just issued. It is free.

## DR. KNOWLES' PRIVATE COURSE IN OPTICS.

Lectures with Diploma \$25.00

Those who desire to study with the Doctor will send in their application.

Students received at any time.

CORRESPONDENCE COURSE PERFECTED.

*The Key to the Study of Refraction.*

50c. per copy,

For Sale by

R. H. KNOWLES, M. D.,  
189 Broadway, NEW YORK.  
Care of JEWELERS' CIRCULAR.

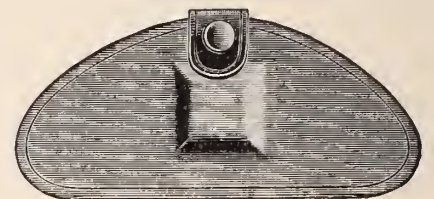

EXTRA THIN.



IN TWO SIZES.

## KOENEN'S NEW SHELL CASE

FOR OFFSET EYEGLASSES.

THE LATEST AND BEST. THIN AND STRONG.

Manufactured and Patented by

**A. KOENEN & BRO.,** 81 Nassau St., N. Y.

SOLD BY JOBBING TRADE.



## The STATIONERS' ENGRAVING CO.,

98 TO 102 NASSAU STREET, NEW YORK.

MAKERS OF

WEDDING INVITATIONS, RECEPTION AND VISITING CARDS

of the Best Quality, which are offered to Jewelers of recognized standing only.

Trade Mark "SILVER WHITE," registered.

# OPTICAL DEPARTMENT.

## Ocular Refraction

AS RELATES TO THE CORRECTION OF VISUAL DEFECTS \*

BY R. H. KNOWLES, M. D.

**NOTE.**—The purpose of this series of articles is to give to the student without his having had any previous technical education, a clear and practical course of instruction in optics with its application to the fitting of glasses. The Correspondence Column is open to all readers of THE JEWELERS' CIRCULAR. All questions asked will be fully answered.

XXXVII.

(Commenced Feb. 27 1895.)

### CHAPTER VIII.

PHOROMETRY (Continued.)

IN our last issue we simply called attention to the principles employed in the use of the phorometer. It will be our purpose in the present article to enter upon the details in using this instrument, with the belief that the majority of the profession at least are acquainted with the subject of asthenopia and its dependence upon the errors of refraction.

The usual method for testing the muscles controlling the movements of the eye whenever the patient complains of pain in the eyes, of headaches, and that while reading the letters or print become blurred, and we suspect asthenopia, is as follows: after testing the vision with the trial case, the ophthalmoscope and the ophthalmometer, we make the test for muscular insufficiency by means of the bar test or Maddox glass rod or Maddox double prism or some one of the various phorometers. The following remarks apply to use of the Stevens phorometer:

We produce homonymous diplopia by placing four degree prisms bases joined, and request the patient to look at the candle flame through the prism, which is placed 20 feet away. The sliding bar for the prisms is made exactly horizontal by means of the spirit level. The principle lies in having the prisms placed on the level, and this instrument can be constructed in several ways as long as the level can be maintained. The popular way of constructing the instrument is to have a rod with a firm pedestal for a base and the horizontal bar for the slides holding the prisms.

If the patient sees two candle flames through the two prisms in the horizontal plane there can be no weakness of the muscles above and below the horizontal plane, for there would be a deviation from the horizontal if any one of these muscles was weakened.

To test the internal and external recti in the same way, we place a prism of six degrees base down in the slide. If the two apparent flames are in the perpendicular, there cannot be a weakness of either of these muscles; should there be an insufficiency, on the other hand, the flames, real and apparent, would lie in the oblique, and a prism which would bring the two flames into the perpendicular would give the number of degrees of muscular insufficiency.

Should it take an eight degree prism to effect this we divide eight by two, which would give us four, and the result equally apportioned between the two eyes would give us the result if we are to prescribe prisms. Prisms for permanent use should never be prescribed over three degrees. The conservative method which is carried out by the leading refractionists relative to this subject is: First, correct the error of refraction; second, experiment with prisms if the correction does not give immediate relief; third, perform tenotomy.

For the benefit of those who may not have entered upon the study of this subject we may mention some of the technical terms employed by Dr. Stevens for the purpose of expressing a tending of the visual lines in asthenopia:

1. *Orthophoria*. A tending of the visual lines in parallelism.

- (a) *Esophoria*. Tending inward.
- (b) *Exophoria*. Tending outward.
- (c) *Hyperphoric*. Tending of one eye above its mate.
- (d) *Hyperesophoria*. Tending down and inward.
- (e) *Hyperexophoria*. Tending up and outward.

The terms which are employed for expressing the various kinds of deviation in strabismus are as follows:

1. *Orthotropia*. Non-deviation of the visual lines.

- (a) *Esotropia*. Convergent strabismus.
- (b) *Exotropia*. Divergent strabismus.
- (c) *Hypertropia*. Deviation of one eye above its mate.
- (d) *Hyperesotropia*. Deviation down and inward.
- (e) *Hyperexotropia*. Deviation up and outward.

(To be continued.)

### Color Photography and Why Pearls Seem Colored.

THE marvels of Roentgen rays distract public attention from the wonderful progress that has recently been made in color photography. In this age of scientific instruction, the man in the street knows that sensations in color are due to rays of light dancing into our eyes, as it were, to different tunes. A beam of colorless light contains all the color producing rays so blended that the separate movements are indistinguishable. When we look at a colored object, such as, for instance, a red and blue macaw, the rays reach our eyes in assorted bevy. The beams of daylight which strike the feathers contain all the colors, blended in a colorless harmony; the rays reflected from them to our eyes have

been disentangled and separated. There are two distinct causes for this separation, and the two marvelous series of color photographs exhibited recently at the Royal Society by Mr. Ives and M. Lippmann were produced by methods dependingly on the different fashions in which natural colors are caused.

Many colors in the feathers of birds are due to the substances known as pigments. These are materials with the physical property of absorbing one set of rays of light and handing on the others. A yellow pigment absorbs from light all the colors of the spectrum but yellow, and hands on only the yellow rays. Some pigments are soluble in oil, some in ether, some in alcohol, many in water. When colored feathers are treated with these solvents the pigments are removed, and the colors due to them disappear from the object, remaining in the solution. Naturally, most of the pigments of animals are insoluble in water, although in the case of one bird, the lion of some seasons since, the red color of the tail feathers dissolves in rain water. When pigments are transparent, light transmitted through them appears most often of the same color as when it is reflected from the surface. A beam of light reflected from a glass of claret sends only red rays to the eye; when the glass is held to the light the rays on passing through the wine to the eye similarly are robbed of all but the producers of red. On the other hand, gold, beaten out to the thinnest leaf, reflects the usual yellow, but allows green to pass through it. The painter relies entirely upon pigments, and daubs his canvas with chemical materials having the same absorbing and reflecting action upon light as the natural objects he is attempting to reproduce. The camera cannot attract pigments from the object upon which it is focussed; but, following a method familiar in color printing, one may take a set of photographs of the same object, each photograph representing only one color.

If a photograph be taken through a plate of glass tinged with a pigment transparent only to, say, red rays, then the negative will reproduce only the red parts of the object. This might be printed in red, or looked at through a red glass, and would faithfully represent the red parts of the object. The photo-chromosome camera of Mr. Ives takes three pairs of images simultaneously, each image picking out rays of one color. His stereoscopic photo-chromosome is an elaboration of the old stereoscope by which two images were seen as one; this ingenious invention combines the six different photographs into one image, to which each contributes its natural color. The specimens exhibited were absolutely lifelike in their vivid and accurate reproduction of natural color, and the method unquestionably will lead almost to a revolution in color printing.

The second source of natural colors is seen in a simple form in the play of color on a pearl. There is no pigment in a pearl, and yet beams of light, reflected from its surface, display the most varied hues. Seen with a



**E. KIRSTEIN'S SONS CO.,**  
MANUFACTURERS OF  
**Optical Specialties,**  
**ROCHESTER, N. Y.**

NEW CATALOGUE NEARLY READY.  
 SEND US YOUR BUSINESS CARD.



## OPPENHEIMER BROS. & VEITH,

### CUTTERS OF DIAMONDS,

### DEALERS IN WATCHES,

65 NASSAU STREET (PRESCOTT BUILDING), NEW YORK.

## SLOAN & COMPANY,

SUCCESSING

JOHN A. RILEY & SLOAN CO.,

**MANUFACTURING JEWELERS,**

23 MAIDEN LANE, N. Y.

HAYS BUILDING.

AUGUSTUS K. SLOAN, Pres.  
 FRANK T. SLOAN, Vice-Pres.

BENNET OSBORN, JR., Treas.  
 ALLAN A. McDONALD, Sec'y.

## Why We Are Leading Locket Sellers.

Our line is most complete—Styles the very newest—We make lockets of all kinds—Gold Lockets, Gold Filled Lockets, Gold Front Lockets, Platinum and Gold Lockets,

Sterling Silver Lockets. We know all about Lockets—have nothing to think of or talk of but Lockets and similar goods. A large line of fobs, flat and drop seals.



Ask your jobber to show you our new Fall lines.

**WIGHTMAN & HOUGH CO.,** Providence and N. Y.



microscope, the surface of the pearl appears wrinkled and puckered with innumerable tiny ridges and hollows. Light, striking on the edges of these, is broken up, the rays of different colors coming off at different angles, as, when a beam passes through a prism, the colored rays emerge separately. These are interference or structure colors, their appearance depending upon the mode in which the structure of the colored object interferes with the natural reflection of light. Many of the most gorgeous hues of feathers are of this kind. M. Lippmann's method of color photography consists in enabling the different rays of light to make such structure on the sensitive plate as will afterward give rise by reflection to the same colors. Behind the transparent, sensitive film of his plate he places a mirror. The colored rays from the natural object strike the mirror, and then, as they are reflected outward, through the plate, raise it into microscopical ridges, the size and distribution of which correspond to wave-lengths of the different rays, just as the direction and size of snowdrifts correspond to the direction and strength of the breezes which raised them. The negative, seen in the ordinary way, is a colorless image of the ordinary kind; but when it is held so that light is reflected from it to the eye, then each ridge reflects the color that caused it, and the total result is a color photograph dazzlingly brilliant and absolutely realistic.

M. Lippmann's assistant threw upon a screen a set of photographs in their natural colors including such diversity of colored scenes as a landscape with a white house shaded by a chestnut, and with a brilliant flower bed in the foreground, all seen in vivid sunlight; a lady in a gay dress lying on a green lawn; and cut flowers in brilliant Eastern jars. His last exhibit was wonderful in itself, and most convincing as to the reality of his method. Upon a gelatine plate on which he had photographed the spectrum he poured water, and then replaced it in the lantern. The water made the gelatine expand, and the delicate ridges were obliterated. No color was visible upon the screen, but, as the water evaporated, the ridges began to throw a tumult of changing color on the screen, more gorgeous and transitory than a smoky sunset. Purples and orange, greens and crimsons glowed and flickered, melted into each other, faded and reappeared, as the gelatine ridges gradually settled down into their original outlines, until when the plate was dry the glory of the rainbow reappeared.—*The Saturday Review.*

### To Unite Broken Pieces of Amber.—

Coat with linseed oil the surfaces to be united; hold the oiled parts carefully over a charcoal fire, a few hot cinders, or a gas light, being careful to cover up all the rest of the object loosely with paper. When the oiled parts have begun to feel the heat so as to be sticky, press and clamp them together, and keep them so until nearly cold. Only that part the edges of which are to be united must be warmed, and even that with care, lest the form or polish of the other parts should suffer

**The Universum Clock.**

**T**HE Universum clock, recently invented, represents the universe. It shows the Earth revolving around its axis, giving the time at the point passing the sun, and shows the stars in the heavens every minute of day and night, in their proper position. It also

contains part of the chart of our globe, divided into 24 hours, showing the difference of time between places all over the globe.

(2.) A golden ball on top of case, represents the sun with sun spots from a photograph taken at Goodsell Observatory, on Aug. 16, 1894.

(3.) A hand pointing from the sun to the

bodies, such as planets, comets, nebulae, and stars of lesser magnitude than the fifth can be exactly located. It is also divided into 12 months with their 365 days, and is operated by a 365 days clock movement, changing once every day.

(5.) In the four corners of the case containing the above, are placed: *a*, the planets Mer-



THE UNIVERSUM CLOCK.

shows the time all over the globe. It consists of:—

(1.) A dial representing the Earth revolving round its axis operated by a 24 hour clock movement. This dial is divided into 24 hours, viz., from 1 to 12 A. M. and from 1 to 12 P. M. The hours have 5 minutes divisions. It

earth.

(4.) A star-chart of the Northern Hemisphere (21 inches diameter) containing its 57 constellations, and all stars of 1st, 2d, 3d, 4th and 5th magnitude. This chart is divided into the degrees of right ascension and declination, so that the position of all heavenly

cury, Venus, the Earth, Mars, Jupiter, Saturn, Uranus, and Neptune, showing their comparative sizes; *b*, Saturn with his rings and moons, from a photograph; *c*, Jupiter with his moons; *d*, Donati's Comet as it appeared in 1858.

It has been a puzzle to many why the day should be divided into two parts on the

**A. WITTAUER,**  
 SUCCESSOR TO  
**J. EUGENE ROBERT & CO.,**  
 IMPORTER AND MANUFACTURER OF  
 PLAIN AND COMPLICATED  
**WATCHES AND**  
**WATCH MOVEMENTS,**  
 19 Maiden Lane, New York.

**DORFLINGER'S**  
**AMERICAN**  
**CUT GLASS.**



915 BROADWAY  
 36 MURRAY ST.  
 NEW YORK.

**AMERICAN WATCH CASE CO.,**

11 JOHN STREET, NEW YORK.

Manufacturers of **FINE SOLID GOLD CASES.**



Sold DIRECT to  
 the RETAIL TRADE only.

**A reputation**  
**the world over**

THE "ROGERS"  
 ANCHOR BRAND OF  
 SILVER PLATED WARE  
 HAS MET ALL COMERS  
 FOR THE PAST FIFTY  
 YEARS.

IT HAS BEEN PERFECTED WHEREVER THERE HAS  
 BEEN A CHANCE TO BRING IT NEARER TO PERFECTION.

ITS BEAUTIFUL DESIGNS AND ITS THROUGH AND  
 THROUGH QUALITIES HAVE WON FOR IT A GOOD  
 REPUTATION THE WORLD OVER.



"ANCHOR" BRAND

FACTORIES:

Hartford, Conn. Norwich, Conn.  
 Wallingford, Conn. Taunton, Mass

**WM. ROGERS**  
**MAN'F'G CO.,**

Office and Salesrooms:  
 Hartford, Conn.

clocks, and the inventor of the Universum clock hailed with pleasure the 24 hours clocks when they appeared some years ago; but alas! they showed 13 o'clock, 14 o'clock and so forth to 24 o'clock, and people did not become accustomed to them.

To make the Universum clock easily understood the dial has been divided into twice 12 hours, so that there is no change in the denomination of the hours. The makers of the clock have, however, abolished the hands of the old clocks pointing from the center to the figures on the margin of the dial, as such a pointing does not represent the movement of the earth; and have instead made the dial to revolve showing the time by the hand pointing from the sun. We are nearest the sun at noon, and as the earth revolves it passes 15 degrees of longitude every hour from the nearest point of the sun until midnight, when we again travel toward that point, and on arrival there, we have made the revolution of the 360 degrees longitude into which the earth is divided, in 24 hours. As the earth revolves round its axis the fixed stars appear to change their position, which is minutely represented by the clock showing the larger fixed stars visible to the naked eye, every minute of day and night, their rising in the east and setting in the west.

The manufacturers of the clock, Universum Clock Co., 1 Beacon St., Boston, Mass., publish from time to time the position of our planets among the constellations, together with the position of the fixed stars at different times, and other appropriate information. The first number contains this information for the months of June and July, 1896. The inventor of the Universum clock is Arthur Sirois, 66 Nassau St., New York. The clock is especially adapted as an ornament for libraries, parlors, offices and ship saloons.

**Friction of Train Pivots.**—It is very important to reduce the friction of the wheel pivots to a minimum quantity, and to make it constant so that the motive power be transmitted with the greatest possible uniformity to the pendulum, which is necessary to enable the latter to maintain its arc of oscillation of the same magnitude. The friction of the pivots is due to the pressure of the motive power and the weight of the wheels. The wheel working nearest to the motive power must have strong pivots, so that they possess sufficient resistance, neither wear the pivot holes to one side nor enlarge them, by which the friction would be increased and at the same time alter the true point of engagement. In tenor with the distance of the wheels from the motive power, the thickness of their pivots must decrease, because these latter sustain less pressure and are subjected to greater velocity than the first pivots.

**A Loving Wife's Advice.**

She urges her worrying husband, in order to increase his business, to read from week to week

**THE 20 DEPARTMENTS**

IN THE JEWELERS' CIRCULAR,  
 PER \$2 00 YEAR.



## Workshop Notes.

**Forming Mass.**—According to a French receipt an excellent mass for taking impressions of coins and metals is obtained by adding about equal quantities of fossil meal and plumbago to thin, fluid molten sulphur. If a sufficient quantity of this mass previously melted over a flame is with a spatula or spoon poured quickly over a coin or medal an impression of extraordinary sharpness is obtained. It is said that in consequence of the plumbago the formed articles do not get dull.

**To Cement Meerschaum.**—If among the many extra jobs, the repairer in the country is asked to cement meerschaum, he can do it best with a small piece of this material which fits into the hole. A good cement is white of egg. He may also stir very fine meerschaum shavings with white of egg and use it, or dissolve caseine in waterglass, stir in finely pulverized magnesia, and use the cement at once, as it hardens rapidly. In place of the magnesia, or together with it, he may also use meerschaum shavings.

**Mainspring in Swiss Watches.**—A fruitful source of annoyance in cheap Swiss watches is the mainspring. These springs are usually of the most inferior order and we find the inner ends full of little short bends, which is a big help toward stopping one of these watches. Usually the spring is too weak at the same time. Although I do not approve of the principle of putting in a strong mainspring to compensate for bad workmanship, still we must have the proper amount of power, and a spring can as easily be too weak as too strong.

**Relation of Train to Balance, &c.**—The relation of escapement to the balance is a subject which is attracting the attention of thinking watchmakers just at the present time, especially as it relates to isochronal adjustment. That the relations of train and escapement to balance and balance spring are not important factors in isochronal adjustments but few who have had any experience will contend. No one except a novice would hold that a balance spring perfectly isochronal in a chronometer escapement would be so in a lever using precisely the same balance; it would not even give a close rate.

**Shape of Drill.**—The forms ordinarily adopted for the blades of drills are too well known to require specific mention. It may be generally formulated that the blade must not be too thick, as if it were, there would not be a sufficient cutting edge. As the hardness of the metal operated upon increases, the thickness of the blade must proportionally increase; or, what amounts to the same thing, the two slopes that form the cutting edges must have a less acute degree of inclination. If this condition of sufficient thickness be satisfied in a drill it will perforate steel well.

**Inattention in Timing.**—One fault in connection with adjusting is that we are apt to overlook seeming trifles. Let us consider that an ordinary watch beating one-fifth seconds makes 432,000 vibrations in twenty-

four hours and if we modify one of these in an almost inappreciable degree we obtain an aggregate result which would astonish us if we did not fully consider the matter. Let the reader, for example, imagine the fork thrown out of poise only one-tenth of a grain, and the excess of the weight so disposed of that the balance had to lift it at a certain relative position to accomplish a vibration; now the claim by some adjusters that there is as much force given back on the return vibration is not tenable, strictly speaking, because of the inertia of the parts. The balance is moving at its greatest velocity when it effects the fork action, and although gravitation is an instantaneous force, it requires a certain definite time to act on matter.

**Watch Oil.**—A good watch oil should not have a disposition to "creep" between 0° F. and 100° F. The gradual spreading of a drop of oil over its immediate surroundings is an imperfectly understood phenomenon, but it depends, among other things, on both the oil and the surfaces to which applied. It is probable that some preparation could be found which, applied around any given oil about a pivot hole, would limit the oil within the circle described by it. So far as the "creeping" belongs to the oil itself, it may be tested by the glass plate placed horizontally in the oven or refrigerator. Let a drop fall on the middle of the glass plate, and examine it at the end of a week, and then at the end of a month. In the case of some oils of a very good reputation for their other qualities, it will be found that the drop has spread over several square inches. In the case of the very best oil, however, the drop will remain as at first put on the plate, round, with no border to it.

**Barrel Hook.**—Many workmen of fair ability make a failure when putting in hook to mainspring barrel. A hook to hold securely should not extend into the barrel more than about one and one-half the thickness of the mainspring coil. A proper hook can be made very quickly in this way: Make a drill to fit, say, the No. 11 hole of your Swiss screwplate, and then cut a nice full thread on the shank above the drill; the wire of which the drill is made is a piece of steel which will fit some convenient split chuck. The method of using it is to let the drill make the hole, and then, turning the lathe by hand, tap out the hole. Keep such a drill for this purpose, and provide about the three sizes corresponding to Nos. 11, 9, and 7, Swiss screwplate, for different size of barrel. To make a hook, take a piece of steel wire and twist to proper shape, cutting on a screwthread to match the tapped out hole in the barrel; cut off the screw and smooth the head; do not make a slot in it; temper it to a purple after hardening and screw into the barrel from the inside, taking hold with a pair of slide tongs; only let the head extend into the barrel a trifle more than the thickness of the mainspring and cut off from the outside and file smooth. A No. 11 screw with a proper size head will hold the small mainspring without any bits of spring to cumber up the barrel.

## Telephone Clock.

AN Imperial German patent has been issued to I. H. Then, of Schweinfurt, for the invention of a telephone clock. The *Allgemeines Journal d. Uhrm.* says as follows:\*



Although various mechanisms of this kind are in the field already, it appears there is still room for more, especially as the one illustrated herewith possesses several merits over the others. Its exterior resembles an American alarm clock; it has three lugs with holes for fastening on a wall; the dial is divided into ten minutes, the glass is perforated, and a button is fastened upon the hand for setting. It is readily manipulated, the hand is set to the desired minute three or five, or six or ten, as the case may be. The clock is wound thereby, indicates the escape of time, and at "end" gives an audible signal. This last point is of great importance, as it is well known that persons will invariably neglect the time.

The clock being very simple, its construction is correspondingly cheap, and if made in a factory, it would still be cheaper than an American clock.

\*A single rate conversation by telephone in Prussia lasts three minutes and costs 2 marks; in Bavaria, 5 minutes. An excess of time is double rates.—NOTE BY ED.

WATCH	<p>GOLD FILLED.</p> <p>MONARCH</p>	CASES
-------	------------------------------------	-------

**O. NEWMAN,**  
Gold and Silver Electro-Plater,  
Etruscan Coloring a Specialty.  
WATCH CASE POLISHING.  
75 Nassau St., Room 8 Rear Building, New York



The strength and durability of our patent safety pins, has made it practical for us to freely replace all broken pins returned to us ; but since the market has been flooded with cheap imitations which are constantly breaking, we have been over-run with broken pins ( not our make ) until the expense, even of returning them, has become a serious matter ; and we hereby inform the trade that we can no longer do this except at the expense of the sender, and request that they look for the patent date on the inside of the pins before sending to us.

B. A. BALLOU & CO.,  
61 Peck Street,  
Providence, R. I.

## MATHEY BROS., MATHEZ & CO.,

Brassus, Switzerland. 21 & 23 Maiden Lane, N. Y.

SOLE AGENTS :

## CHAS. MEYLAN WATCHES.

# SPLITS

A SPECIALTY.

## AMERICAN WATCH TOOL CO.

ESTABLISHED 1872.  
INCORPORATED 1894.



THE  
**Webster-Whitcomb**

GROWS IN POPULARITY

PRICES AS LOW AS CONSISTENT WITH QUALITY.

Ask your Jobber for Price List of 1895 or write to us at

Stoney - Batter Works, Chymistry Dist., Waltham, Mass.



WE HAVE  
ON HAND

A Large Number of Small

## Advertising Cuts

Specially Designed for JEWELERS'  
ADVERTISING, such as above, at

75 Cents per Electrotype.



SEND FOR PROOF SHEET.



THE JEWELERS' CIRCULAR PUB. CO.,  
189 Broadway, New York.

## THE SWAN FOUNTAIN PEN

Reputation World Wide.  
Made upon Distinct Principles.  
Is a Compressed Air Pump.  
Simply Wet the Insides to Provoke  
an Energy.

W. W. Stewart, Inventor and Patentee.

A variety of Styles and Prices

- 3 Sizes Safety Swans.
- 3 Sizes Self-filling Swans.
- 3 Sizes Adjustable Feed Swans.

MABIE, TODD & BARD,  
NEW YORK AND LONDON.

A. J. COMRIE,  
AUCTIONEER,  
22 John St., N. Y.  
SPECIAL SALESMAN OF WATCHES, DIAMONDS,  
BRIC-A-BRAC, FOR ESTABLISHED JEWELERS.  
WRITE FOR PARTICULARS.

QUICK SELLERS.....  
IN STERLING SILVER  
ARE MADE BY  
CODDING BROS. & HEILBORN,  
North Attleboro, Mass.

H. M. RICH & CO.,  
Jewelry - Auctioneers,  
21 School Street,  
BOSTON, MASS.





### The Rambler's Notes.

WHAT THE RAMBLER SAW AND HEARD AMONG THE DEALERS IN ART POTTERY, CUT GLASS, BRONZES, ETC.

FINE ADDITIONS TO F. BING & CO.'S CLOCK LINE. **H**ANDSOME large green marble clocks mounted with tall, gilt bronze figures are among the additions to the clock department of Ferd. Bing & Co., 10 Washington Place, New York. The pieces with the figures range from 27 to 36 inches high, the marble forming a base for the large figures or groups on the clocks and side pieces. The clock is, in some instances, set in the marble, and in others is above it. A most extensive new line of gilt and crystal regulators has just been opened by this firm. The clocks show beautiful cloisonne enamel frame work and borders of studded white or colored rhinestones.

NEW AND BEAUTIFUL TERRA COTTA FIGURES. **O**NE line of terra cotta figures and busts shown in the art pottery department of Geo. Borgfeldt & Co., 18-22 Washington Place, New York, contains pieces ranging from a six inch bust to a life size negro boy. Among the busts may be seen a collection of subjects representing women of all nationalities, including Japanese, Zulu, American Indian, African and European types. Among the principal subjects in the large figures are: Othello, Napoleon, Senator (Roman), water carrier and water merchant. All these subjects are decorated in the natural colors of their prototypes.

THE BEAUTY OF PASSARIN'S DECORATIONS. **T**HE beauty of R. Passarin's figure decorations on Italian faience seems to grow rather than lessen with the increase in the production of his ware. A new consignment, opened by Chas. Ahrenfeldt & Son, 52 Murray St., New York, contains a number of large plaques, plates, trays and wall pieces, ornamented with heads of various types of Italian women. The artist's usual exquisite figure panels are profusely scattered over a line of vases, cups, jars, jugs and small ornamental pieces and novelties. Very rich floral decorations also appear in a similar line.

#### ARTISTIC CARRARA FIGURES.

**T**HE marble department of Glaenger Frères & Rheinboldt is now being opened at their new building, 26 and 28 Washington Place, New York, with a fine collection of artistic sculptures in Carrara marble. Probably the large seated figure of the "Girl with Birds" will be considered the *chef d'œuvre* by many, though equally artistic are the large busts "Architecture," "Sculpture," "Music" and "Morning Star."

#### DAINTY CHINA LAMPS.

**T**O meet the demand for dainty china lamps for country cottages, Hinrichs & Co., 29 and 31 Park Place, New York, are showing a collection of new Dresden and Dresden style lamps which contain all the present popular ideas in decoration and coloring. Banquet lamps, large and small table lamps, princess lamps and dainty night lamps show the usual multicolored raised flowers and figures of the Dresden styles and the new all blue flowers and Delft effects.

#### THREE NEW STRAUS CUT GLASS PATTERNS.

**T**HE assortment of patterns in the cut glass of L. Straus & Sons has been augmented by the introduction of three new cuttings known as the "Coronation," "American Beauty" and

consists of a brilliant mass of small but deeply cut hobnails. The "American Beauty" is a staple pattern of medium grade which L. Straus & Sons expect to be one of their "leaders" this season. It is composed wholly of large and small rosettes. These two patterns, with "Duchesse," the new and pretty popular priced cutting, are shown in a full line of articles at L. Straus & Sons' warerooms, 42-48 Warren St., New York.

THE RAMBLER.

### Managed Savages With Watches.

**D**URING the course of his lecture in Pittsburgh, Pa., the other evening, Paul du Chaillu, the African explorer, told how he once controled a race of savage cannibals while he was on the Dark Continent. He had a number of Waterbury watches, whose ticking completely non-plussed the savages and caused them to regard him as a spirit. He made a practice of leaving one of these watches in a village where he had stopped. After a while the watch of course ran down and stopped, and the cannibals said that the spirits had gone to overtake their master. When Du Chaillu returned to these villages he always got the watch that he had left behind, and, unobserved, wound it up again. The natives heard the ticking continued, swore again that the explorer was a spirit, and did their utmost to please him.

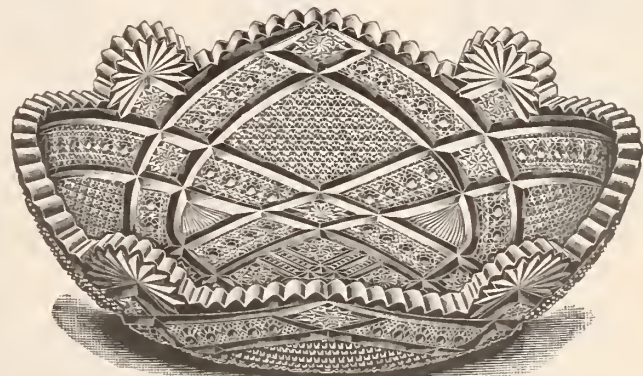

"CORONATION" PATTERN—L. STRAUS & SONS.

Duchesse." The "Coronation," named in honor of the recent Russian ceremony, is one of the richest patterns its makers have ever offered to the public through the jewelry trade, and

G. W. Cameron, Poplar Bluffs, Mo., has given a realty deed of trust for \$800.

Aug. Winkler, Poplar Bluffs, Mo., has given a deed of trust amounting to \$400.

**Soldering Aluminium.**

**F**RENCH metalworkers, says *Journal der Goldschmiedekunst*, use five kinds of solder for soldering aluminium articles. These solders are composed as follows (all parts are by weight):

- I. Zinc 80, copper 8, aluminium 12;
- II. Zinc 85, copper 6, aluminium 9;
- III. Zinc 88, copper 5, aluminium 7;
- IV. Zinc 90, copper 4, aluminium 6;
- V. Zinc 94, copper 2, aluminium 4.

These solders are always prepared by melting copper and aluminium first, adding the zinc last. The copper is melted first, and the aluminium, divided into three or four parts, is then added gradually. The aluminium being much lighter than the copper, the two are diligently stirred with an iron rod, so as to commingle them intimately. Immediately after the last portion of the aluminium has been added the zinc is thrown into the crucible, and at the same time a small quantity of fat or resin; the whole is then quickly stirred, the crucible lifted out of the fire, and the alloy poured into iron ingots lubricated with coal tar, oil or benzine. Care is to be taken to end the melting immediately after having added the zinc, as this volatilizes quickly, thereby leaving the solder short of the requisite quality. The fat or resin is added to prevent the oxidation of the zinc; the temperature of the melted two metals is so high that a large part of that metal would be driven off. Zinc entirely free from iron should only be used; if the percentage be ever so small, the character of the solder will be changed.

A soldering vehicle of aluminium must be used with these solders. If of some other metal a secondary alloy is likely formed impairing the quality of the solder.

No. 1 is to be used for small objects, such as trinkets; Nos. 2, 3 and 4 for larger articles, such as coffee pots, pitchers, etc.

It is of course the duty of THE CIRCULAR to place before its readers all kinds of working receipts—if possible A No. 1, but as these do not float around constantly, then B No. 2 down to X No. 0000. Above receipts warn against the use of zinc with even a suspicion of percentage of iron, but advises to stir the alloy with an iron rod; next, it again forbids the use of a soldering vehicle of iron, for fear of contamination. The receipts may be all right, but the part objected to is not.

**To make Metallic Precipitations Stick**

—When in galvanic silver or gold plating the coating will not become fastened, the operator may regard it as an evidence that the article is not sufficiently clean, although an unduly strong current will act likewise. A good process to unite the coating well with the underlay is to dip the article before entering it into the galvanic bath, into quickening water. This is an old and much employed process. If from the gilding or silvering bath a part of it is taken out and diluted with about 20 times the quantity of water, the article dipped into it will receive a film of the corresponding metal, which adheres firmly, and retains the coating subsequently precipitated upon it.

**THE BROKEN VASE OF AMETHYSTOS.**

**T**AKE in thy pious hand the crystal bright  
Transparent image of the Eternal light.  
Pleased with its luster, every god shall hear  
Thy vows with favor and concede thy prayer.  
But how to test the virtue of the stone,  
A certain way I will to thee make known  
Without fire's aid to raise the flame divine  
This wondrous gem lay thou on splintered pine;  
Forthwith, reflecting the bright orb of day  
Upon the wood it shoots a slender ray;  
Caught by the unctious fuel th'shall raise  
First smoke, then sparks, and last a mighty blaze.  
Such we the fire of ancient Vesta name;  
Loved by the immortals all, a holy flame;  
No fire terrestrial with such graceful fumes,  
The fatted victim on their hearths consumes.  
Yet though of fire, the source, strange to be told,  
Snatch from the flame the stone—'Tis icy cold.

—From the *Ancient Greek*.

**AMETHYSTOS.**

"Oh, gather thou the fragments, let not one crust remain,  
Of scenes, of joys, of home, of friends so long departed."

—Life of Junius.

Oh gather up the fragments, what sacred gifts remain,  
Festoon upon thy bosom veil what's found pure hearted;  
No moral potter made its mould, magic-divine supplied  
Its amber, quartz and tint of art in grace erected.  
For life's viutage bouquet, your meadow sweet had died;  
Oh gather up the fragment years that thou neglected  
Thy amber urn to dust now turns, but form in memoir float,  
As clear around the marsh and lake a lily pearl reflected,  
In issue of whose estival, life and every note  
That tones the harmony of home which thou rejected.  
That bloom of youth, of charity, as helen of thy childhood  
Upon the shores of L'Acadie thy amethyst had gathered,  
'Till cacti of rude oathsome hurst, the pearl of maidenhood  
Who feru'd thy path to fame, by moss, and thou was smothered.  
Thy garlands by ambition forged, thou false, coroual lustre,  
Allured thee on to haunts of shame, whose tinsels lie flattered.  
Then gather up the fragments, for memoir grace hereafter,  
O'er youth, o'er prime and wisdom's age, who, vanity thou flattered.  
Oh, gather ere the fire of time allays by haud of potter  
Your chard and splints now crucibled in furnace bath now shattered.

**PATEK, PHILIPPE & CO., GENEVA, SWITZERLAND.**

MAKERS IN THE HIGHEST QUALITY OF

**Fine, Plain, Complicated And Decorated Watches**

IN 15 DIFFERENT SIZES.

INTERCHANGEABLE PARTS.

NEW YORK OFFICE, 68 NASSAU ST.

ALFRED G. STEIN, Representative.



**V**

Means everything that is first quality in Watch Glasses.

**T**

They are used by more Watch and case makers than all others.

**F**

Their success has induced others to copy the label but not the quality.

**WM. SMITH & CO., 5 and 7 MAIDEN LANE, NEW YORK. 61 PECK ST., PROVIDENCE, R. I.**

ESTABLISHED 1854.



MANUFACTURERS OF

**Gold, Silver and Rolled Plate Chains and Jewelry.**

Novelties in Gold and Silver Bead Necklaces and Bracelets. Also a large line of Chain Trimmings and Silver Rings



Send For New Price List.

**HENRY C. HASKELL,**  
11 John St., New York.

**FINE CASES . . . . .**

for Jewelry, Silverware, etc. Hardwood Chests, Trays and sample cases. Business established in 1876.

**Samuel C. Jackson's Son, 180 B'way, N. Y.**

DON'T FORGET THE JEWELERS' CIRCULAR PUBLISHING CO.'S BOOK LIST when in want of any technical book in the Jewelry or Kindred Trades.



Copyright, 1896, by The Jewelers' Circular Pub. Co., 189 Broadway, New York.

A Jeweler's Necessity

For eight months THE JEWELERS' CIRCULAR has had under way a work that will comprise the trade-marks of every branch of the Jewelry, Watch, Clock, Silverware, Silver Plated Ware, Optical Goods, Precious Stone, Art Pottery, Bric-à-brac, Cut Glass and cognate lines of the Jewelry Industry.

The work is now nearing completion. We consider it will be the most valuable book that has ever been issued to the Jewelry trade.

It is a work which the retailer and wholesaler will immediately appreciate.

It will be a book of constant reference, and will be consulted more perhaps than any other book issued to the trade.

It will be a book of daily use.

It will be sold at a figure that will guarantee its rapid distribution.

In addition to illustrations of the various trade-marks and the names and the addresses of the firms to whom they belong, and the class of goods to which they appertain, the work will contain other interesting and valuable information bearing upon the subject of trade-marks.

Members of the Trade, Manufacturers, Wholesalers and Retailers should at once place their orders for

“TRADE-MARKS OF THE JEWELRY AND KINDRED TRADES.”

\$1 per copy. Bound in Cloth. Payable now or upon delivery of Book. Detach order below and forward to the Jewelers' Circular Publishing Co., 189 Broadway, New York.

Those firms who have as yet not sent electrotype, print or drawing of their trade-mark or trade-marks are requested to do so at the earliest possible moment.

ADVANCE ORDER BLANK.

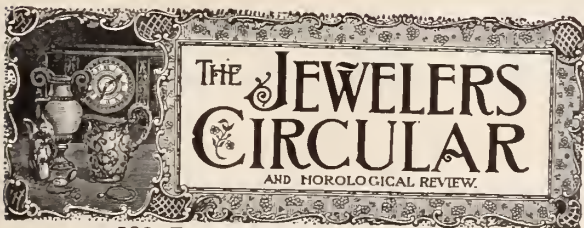

189 Broadway, New York.

1896

Please file this order for.....copy of

“Trade-Marks of the Jewelry and Kindred Trades”

for which I agree to pay \$1.00 per copy, postage prepaid, upon delivery of book.

Name.....

Street.....City.....State.....



**CYCLING PROGRESS  
EXEMPLIFIED.**

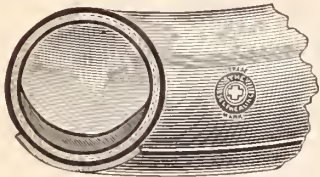

**THE WONDERFUL  
SELF-HEALING TIRES**

are single tube, finest rubber, finest wove Sea Island cotton fibre, re-enforced inside and outside on tread, and no better tire can possibly be made. They are fully guaranteed against all climatic changes, are the most resilient ever made, and when punctured instantly heal the wound of their own volition.

THEY WEIGH NO MORE THAN OTHERS,  
COST NO MORE,  
AND ARE WORTH TEN TIMES MORE.

—SEND FOR TIRE BOOKLET—

**Wm. H. CAHN, GENERAL MANAGER,**  
48 and 50 Maiden Lane, New York.

**BY EVERY TEST THEY ARE THE BEST.  
THE UNIVERSAL FAVORITES.**



**SUPERB  
Olympic  
BICYCLES**

For sale by more than 2,000  
Jewelers, and constructed to meet  
the demand for finest quality.

For Adults and Juveniles.

**SEND FOR EXQUISITE  
CATALOGUE.**

Top Grade "Olympics" have SELF-  
HEALING TIRES.

Olympic Cycle Mfg. Co.,  
N. Y. Office: 35 LIBERTY STREET

General Jobbing Ag'ts, S. F. MYERS & CO.,  
WHOLESALE JEWELERS, Myer's Building, New York

**RECEIVER'S SALE!**

**TRADE OPPORTUNITY.**

Entire Stock of

**CHAS. JACQUES CLOCK CO.,**

22 Cortlandt St., New York,

**...Must Be Closed Out...**

**Latest Paris Novelties,  
all New Importations  
of this Spring**

Together with LARGE STOCK of

**ELLIOT CHIME CLOCKS,**

And a Fine Line of Other

**HALL CLOCKS.**

By order of

**ALBERT C. WALL, Esq.,**

Receiver.

**CUT GLASS FOR SILVERSMITHS**



**STANDARD CUT GLASS CO.,**

545 to 549 West 22nd Street,  
NEW YORK.

**BAWO & DOTTER,**

26-32 BARCLAY ST.

NEW YORK.

P. O. Box 1872.

**NO LARGER STOCK**

OF

**HALL  
CLOCKS**

IS SHOWN IN  
THIS CITY.

Large Stock

OF

**MOVEMENTS.**

**NEW DESIGNS  
IN CASES.**



**CAMPBELL-METCALF SILVER CO.,  
SILVERSMITHS,**



ALL GOODS 925/1000 FINE.

Factory, Providence, R. I. Offices, New York and San Francisco.

**DUBOIS WATCH CASE CO.**



REGISTERED.

**FINE HAND MADE  
SOLID GOLD CASES.**

A PRIDE TO THE MAKER,  
DEALER & WEARER.

**L. LELONG & BRO.,**

GOLD AND SILVER

**Refiners, Assayers and Sweep Smelters,**

◁ SOUTHWEST CORNER HALSEY AND MARSHALL STREETS, ▷

**NEWARK, N. J.**

SWEEPINGS A SPECIALTY.

**STERLING**

SHEET AND WIRE SUPPLIED ALL SIZES.

**J. SCHAWEL & CO.,**

Gold, Silver and Platinum Refiners.

29 John Street, N. Y.

**ROY PHOTO MINIATURES**  
GIVE THE BEST RESULTS.

**ROY WATCH CASE CO., 23 MAIDEN LANE, NEW YORK.**

ALBERT LORSCH.

ALFRED KROWER

**ALBERT LORSCH & Co.,**

LORSCH BUILDING

37 & 39 Maiden Lane,  
NEW YORK.



167 Weybosset St.,

PROVIDENCE, R. I.

**IMPORTERS OF DIAMONDS, RUBIES, EMERALDS, ETC.,  
AND IMITATION STONES THEREOF.**

•• Fine Miniatures on Ivory and Enameled Paintings. ••

**DIAMONDS** Importers and Cutters. **L. & M. KAHN & CO.,** 172 Broadway, Cor. Maiden Lane, N. Y. **DIAMONDS**

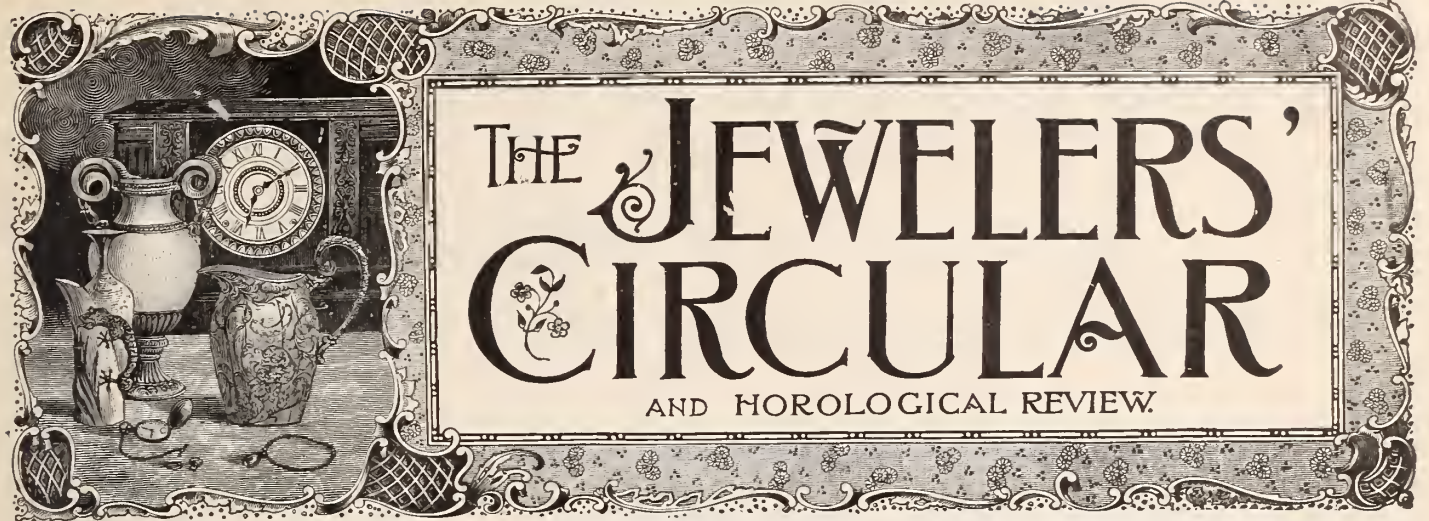

Copyright by THE JEWELERS' CIRCULAR PUB. CO.

189 Broadway, New York.

Entered at the Post Office in N. Y. as second-class matter

VOL. XXXII.

NEW YORK, WEDNESDAY, JULY 29, 1896.

No. 26.

## THE GENESIS AND ARTISTIC DEVELOPMENT OF THE LOVING CUP.

Copyright, 1896, by THE JEWELERS' CIRCULAR PUB. CO.

## PART V.

IN its uses, the mazer can be claimed to be related to the loving cup. Primarily this ancient domestic article was a large drinking bowl which was used by the family at table and was drunk from by the different members, which custom is not far removed from that embodied in the loving cup. It is easier, says Mr. Cripps in his noted work,\* to say that the mazers were for centuries among the commonest articles in domestic use, than to give a satisfactory reason for their being usually called "murræ" in mediæval inventories, or to define the material of which they are made. On the former of these points a great deal of learning has been expended by the antiquaries of past generations, so much indeed that it ought to have gone farther than it has towards settling the latter. Du Cange only ventures to say that mazers are "pretiosiora pocula," adding that opinions differ as to what they were made of. First he quotes Somner, a well known writer of the early part of the seventeenth century, who supposed that they were wooden vessels and made of maple, but he proceeds himself to say that the better opinion is that they were the vessels called "myrrhine" in classical ages. Other authorities are then cited who in turn suggest gum, porcelain, shell, metal, and, lastly, onyx as the materials of which they were probably fashioned. Somner was guided by the fact that the word "maeser" signified, in the Flemish language, an excrescence of the maple tree; and notwithstanding the opinion of Du Cange, which was no doubt influenced by inventories of the twelfth and following centuries, in which he found these vessels usually described as "de murrâ," "de murro," or by the adjective "murreus," there can be no doubt that nothing but wood was in ordinary use in mediæval

days for utensils such as these. The menders of broken cups in Paris are said by John de Garlandia, in the eleventh century, to have worked upon cups of many different kinds of wood, "de murris, planis, brucis, de acere, et tremulo," and he gives it as the opinion of some that the "murrâ" was a tree mentioned

early wills and the inventories which are often appended to them, will go far to convince us that mazers were merely the best sort of wooden bowls, and that these favorite drinking vessels were made of the speckled portions of the maple tree, from which they derived their name. The word "maser" is explained by Skinner, an antiquary of the same century and as trustworthy as Somner, to mean a wooden cup, "proculum ligneum, a Belg. maeser, tuber ligni aceris ex quâ materiâ præcipue hæc pocula confici solebant;" and to this may be added Planta's definition of it, "un neud oubosse à un arbre nomme erable."

The same vessel was called, in French, *madre*, which, says Cotgrave, is used "of wood whose grain is full of crooked and speckled streaks or veins." The German *maser* is a spot, speck, or the grain of wood; *maserholz* is veined wood in the same language, and *maserle*, maple-wood or the maple-tree. From this source the English word *mazer* is clearly derived. In old inventories, the word is often turned into an adjective; *mazereus* and *mazerinus* are Latin, and *meslyn* or *messilling* English forms in which it is found. The latter recalls the lines of Chaucer:

"They fet him first the swete win,  
And mede eke in a maselin,  
And real spicerie."

—*Rhyme of Sire Thopas*, v. 13, 780.

Such a *meslyn* is described more in detail by Spenser:

"A mazer ywrought of the maple wood  
Whereon is enchased many a fair sight  
Of bears and tigers that made fierce war."

—*Shepherd's Calendar*, August.

That "masere" was a wood of price may be gathered from old romances, French and English. Several of the French are quoted by Du Cange and De Laborde, and with these extracts may be read the lines from "Syre Gawene and the Carle":

"The harpe was of mesere fyne,  
The pyynays were of gold I owene."



A MODERN TYG, OR LOVING CUP, IN SILVER.  
R. WALLACE & SONS MFG. CO.

by Lucan—in *auro murrave bibunt*. In England, too, "treen" vessels preceded pewter, as did pewter silver plate.

Beech made their chests, their beds, their join'd stools;  
Beech made the board, the platters, and the bowls."

—Cowley.

A reference to the older English poets, or to

\*The major part of this chapter is derived from "Old English Plate," by Wilfred Joseph Cripps, M. A., F.S. A. London, John Murray.

# KENT & STANLEY CO., LTD.,

## JEWELERS AND SILVERSMITHS,

### SEAMLESS GOLD FILLED CHAINS, JEWELRY, SILVER NOVELTIES.

NEW YORK OFFICE,  
21 and 23 Maiden Lane.



BOSTON OFFICE,  
403 Washington Street,

FACTORY, PROVIDENCE, R. I.

## NEW DESIGNS IN ALL LINES.

ALL OUR SILVER GOODS ARE GUARANTEED 925-1000 FINE.

### THE SPENCER OPTICAL INSTITUTE

OUR STUDENTS ARE THE SUCCESSFUL OPTICIANS.

OUR COURSE.

PRACTICAL,  
COMPREHENSIVE,  
NON-CLASSICAL.



YOUR GAIN.

KNOWLEDGE,  
PRACTICE,  
WEALTH.

SPENCER OPTICAL MANUFACTURING CO., 15 Maiden Lane, N. Y.

### BAND RING MOUNTING



DESIGN  
PATENTED  
Sept. 24,  
1895.



**CHARLES KNAPP,**  
MANUFACTURING JEWELER,

41 & 43 Maiden Lane, New York.

SPECIALTY: SUPERIOR LADIES' and CHILDREN'S RINGS

## PARTICULAR ATTENTION

IS CALLED TO THE NEAT AND RICH  
STYLE OF OUR BOXING. OUR GOODS  
LOOK HANDSOMELY ON THE SHELF  
AND THE QUALITY ATTRACTS THE  
PURCHASER.

TRY THEM.



### CHOICE PAPERS

**PARSONS & GREENE Co.,**

MANUFACTURING STATIONERS,

HOLYOKE, MASS.

HERE IS . . .

**The Perfect Skirt Supporter.**



Applied to any belt in an instant.  
Twin hooks hold skirt and waist immovably.  
Made of an extra heavy piece of Sterling.  
No solder or rivets.  
A variety of patterns in plain Sterling, Sterling gilt or 14k gold.

**THE TENNANT COMPANY,**

33 UNION SQUARE, :: NEW YORK.

Our Fall line of Toilet Ware is now ready—write for prices.

FOR RELIABLE OPTICAL WORK  
SEND TO

JOS. FRIEDLANDER & BRO.,  
OPTICAL LENS GRINDERS,  
9 MAIDEN LANE, - - NEW YORK.

SEND FOR DESCRIPTIVE CIRCULAR OF OUR FRAME AND LENS CABINET.

**THE SWAN FOUNTAIN PEN**

Reputation World Wide.  
Made upon Distinct Principles.  
Is a Compressed Air Pump.  
Simply Wet the Insides to Provoke  
an Energy.

**W. W. Stewart, Inventor and Patentee.**

A variety of Styles and Prices

- 3 Sizes Safety Swans.
- 3 Sizes Self-filling Swans.
- 3 Sizes Adjustable Feed Swans.

**MABIE, TODD & BARD,**

NEW YORK AND LONDON.

**CROUCH & FITZGERALD.**

Jewelry Trunks  
and Cases,

161

Broadway,  
Bet. Cortlandt and  
Liberty Sts.,  
688 B'way,  
701 6th Ave.,  
NEW YORK.



**Why We Are  
Leading Locket Sellers.**

Our line is most complete—Styles the very newest—We make lockets of all kinds—Gold Locket, Gold Filled Locket, Gold Front Locket, Platinum and Gold Locket,



Sterling Silver Locket. We know all about Locket—have nothing to think of or talk of but Locket and similar goods. A large line of fobs, flat and drop seals.



Ask your jobber to show you our new Fall lines.

**WIGHTMAN & HOUGH CO.,** Providence and N. Y.



**V**

Means everything that is first quality in Watch Glasses.

**T**

They are used by more Watch and case makers than all others.

**F**

Their success has induced others to copy the label but not the quality.

**NEW ORNAMENTS**

. . IN . .

**STERLING SILVER.**

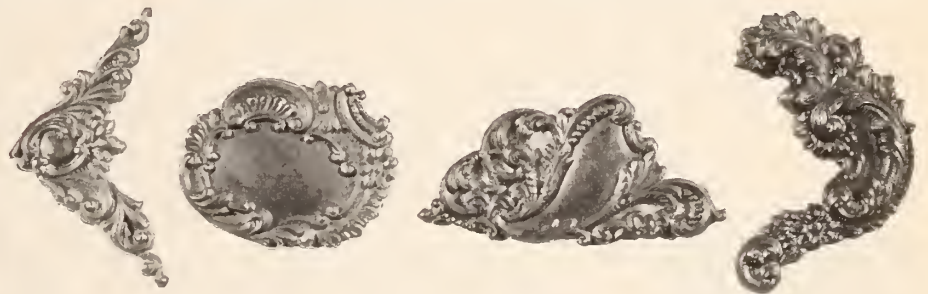

[Many Designs in

Galleries, Belt Buckles,  
Belt Slides AND Belt Fastenings,

ALWAYS SOMETHING NEW.

**THOMAS W. LIND,**

Manufacturer of

**JEWELERS' FINDINGS.**

67 Friendship Street,

PROVIDENCE, R. I.

The Scottish ballad of Gil Morrice places the silver cup and the mazer dish together on the baron's table:—

Then up and spake the bauld baron,  
An angry man was he;  
He's tain the table wi' his foot,



CONVENTIONAL SILVER MODERN TYG,  
OR LOVING CUP,  
HOWARD STERLING CO.

Sae has he wi' his knee;  
Till siller cup and mazer dish  
In flinders he gard flee."

It may be noted that in the reign of Edward III., the manor of Bilsington Inferior was held by the service of presenting three "maple" cups at the king's coronation. Hone records that this service was performed by Thomas Rider at the coronation of George III., when the king, on receiving the maple cups, turned to the Mayor of Oxford who stood at his right hand and, having received from him for his tenure of that city a gold cup and cover, gave him these three cups in return.

While the best and most highly prized bowls were always of maple, it is quite possible that the term "mazer" originally proper to those of maplewood only, was afterward extended to all bowls of similar form, regardless of the materials of which they were made. "Dudgeon" wood, whatever that may be, occurs in more than one English will. Beech has already been mentioned, and some have supposed that even if the word "mazer"

sometimes signifies maple, it is more properly applied to walnut wood. Again, the half of a calabash or gourd having a hard rind was sometimes employed, and Octavius Morgan suggests that the "print" or boss usually found in the bottom of mazer bowls had its origin in the necessity of covering with a plate of metal the point where the fibres of such gourds were clustered in a knot. This may well be so, but similar bosses are commonly found in very ancient cups of silver, as well as of wood or gourd; so much so that an ornament in the bottom of the cup may be considered a general fashion. Gourds and other like substances may have been used, but wood and the turner's art more often provided drinking vessels for our forefathers; and while the simple "beechn goblets" so dear to the poets have perished, a few of the more valuable sort have been preserved to our own time. Those which have come down to us are of maple wood, almost without exception.

So much for the name and materials of these bowls, which seem to have been valued in proportion to the beauty of the wood of which they were made, the knots and roots of the maple being especially prized for their



MODERN TYG, OR LOVING CUP, OF SILVER PLATE,  
MERIDEN BRITANNIA CO.

veined and mottled grain. As knots would not be very thick, and therefore the bowls made

of them shallow, their depth was increased by mounting them with high metal rims which is one of their characteristic features. This rim answers the further purpose of ornamenting and adding to the value of choice specimens of wood, and it was frequently of silver or silver-gilt, and bore an inscription running round it. The elaborate ornamenta-



MODERN TYG, OR LOVING CUP, OF SILVER PLATE,  
MERIDEN BRITANNIA CO.

tion found upon some of them, and particularly their enameled bosses or prints, have suggested a doubt whether they were really intended for use as drinking cups; but the numbers in which they are found, and their enumeration in all cases among other domestic utensils for the service of the table, would be conclusive evidence on this point, even if their use were not often expressly mentioned. Such a cup was "le hanap du Roy S. Louis dan lequel il beuvete, fait de Madre avec sou couvercle de mesme matiere garny d'un pied d'argent doré et dedans icelui hanap au milieu du fond en email de demy rond taillé de fleurs-de-lys d'or à champs d'azur." The accounts of Stephen de la Fontaine, silversmith to the King of France in 1350, include "un hanap de madre fin, a tout le couvercle, duquel l'en sert le Roy a table;" also "madres et caillers pour boire vins nouveaux," and other similar entries.

A will proved in York in 1446, disposes of no less than thirty-three "murre usuales," besides twelve "murre magna et largæ," and two of such importance as to have had names assigned to them. These must also necessarily, judging by their description and number, have been ordinary household requisites. Others bore inscriptions which of themselves prove, if proof were needed, that they were intended for wine cups. A well known specimen, already illustrated in a previous part of this article, in the collection of the late Evelyn Philip Shirley, of Eington, bears the legend:

"In the name of the Trinitie  
Fille the kup and drinke to me."

This cup is of polished maple, and is said to be of the time of Richard II. It is figured in Parker's "Domestic Architecture of the Middle Ages." In more than one country church a mazer now serves as an alms dish; but perhaps even these were originally acquired for festive purposes.



JEWELERS SHOULD SEE THAT  
THIS TRADE MARK IS STAMPED  
UPON EACH AND EVERY PIECE OF

STERLING SILVER GOODS THEY BUY. IT IS A GUARANTEE OF QUALITY AS ABSOLUTE AS THE HALL MARK OF ENGLAND.

925-1000  
Pure Silver.

Gorham Mfg. Co.,  
SILVERSMITHS.

NEW YORK, CHICAGO, SAN FRANCISCO.  
WORKS, PROVIDENCE.



# AIKIN, LAMBERT & CO.,

MANUFACTURERS OF

FINE GOLD PENS, HOLDERS, PENCILS,  
TOOTH PICKS, and NOVELTIES.

PAUL E. WIRT FOUNTAIN PENS, at new and lower prices . . .  
MERCANTILE FOUNTAIN PENS, guaranteed to give satisfaction.

Catalogues with terms and discounts furnished to the trade.

BRANCH, 103 STATE STREET, - - - CHICAGO.

# AIKIN-LAMBERT JEWELRY CO.,

IMPORTERS OF

## DIAMONDS.

JOBBER IN

WATCHES, JEWELRY, CHAINS  
NOVELTIES, ETC.

LATEST DESIGNS.

LOWEST PRICES

19 MAIDEN LANE, NEW YORK.

**O. NEWMAN,**  
Gold and Silver Electro-Plater,  
Etruscan Coloring a Specialty.  
WATCH CASE POLISHING.

75 Nassau St., Room 8 Rear Building, New York

**H. M. RICH & CO.,**  
Jewelry - Auctioneers,  
21 School Street,  
BOSTON, MASS.

**QUICK SELLERS.....**  
IN STERLING SILVER  
ARE MADE BY  
**CODDING BROS. & HEILBORN,**  
North Attleboro, Mass.

# AMERICAN WATCH TOOL CO.

ESTABLISHED 1872.  
INCORPORATED 1894.



THE  
**Webster-Whitcomb**

1-4 Size.

GROWS IN POPULARITY

PRICES AS LOW AS CONSISTENT WITH QUALITY.

Ask your Jobber for Price List of 1895 or write to us at

Stoney-Batter Works, Chymistry Dist., Waltham, Mass.

# CARBORUNDUM

THE GREATEST ABRASIVE YET DISCOVERED.

Four times the Labor and Expense-saving qualities of Emery, Corundum or other abrasives.  
Adapted for Lapidary Work, Grinding, Polishing and every operation where a perfect abrasive is necessary.

## Price List of Carborundum Wheels.

ACHESON'S PATENT, February 28th, 1893; February 26th, 1895.

DIAM. IN.	THICKNESS IN INCHES.																MAX. REV.
	1/8	3/16	1/4	5/16	3/4	1	1 1/4	1 1/2	1 3/4	2	2 1/4	2 1/2	2 3/4	3	3 1/2	4	
1	\$.15	\$.15	\$.20	\$.20	\$.20	\$.25	\$.30	\$.30	\$.35	\$.40	\$.40	\$.45	\$.50	\$.50	\$.60	\$.70	18000
1 1/2	.20	.25	.25	.25	.30	.30	.35	.40	.40	.45	.50	.55	.55	.60	.70	.75	14000
2	.20	.30	.30	.30	.35	.40	.45	.50	.55	.60	.60	.65	.70	.75	.85	.90	11000
2 1/2	.25	.35	.40	.45	.50	.55	.65	.70	.80	.90	1.00	1.10	1.20	1.40	1.50	8500	
3	.30	.45	.55	.60	.65	.75	.85	1.00	1.15	1.25	1.40	1.50	1.60	1.75	2.00	2.20	7400
3 1/2	.40	.50	.65	.70	.80	1.00	1.15	1.30	1.45	1.65	1.80	1.95	2.10	2.20	2.55	2.90	6300
4	.50	.60	.75	.85	1.00	1.20	1.40	1.60	1.80	2.00	2.20	2.40	2.60	2.80	3.20	3.60	5500
5	.70	.85	.95	1.15	1.25	1.60	1.95	2.30	2.60	3.00	3.30	3.65	3.95	4.25	4.90	5.55	4400
6	.95	1.10	1.30	1.55	1.75	2.20	2.70	3.15	3.60	4.10	4.55	5.00	5.45	5.90	6.80	7.70	3700
7	1.25	1.45	1.65	1.95	2.30	2.95	3.50	4.15	4.80	5.40	6.00	6.60	7.20	7.80	9.00	10.25	3160
8	1.50	1.70	2.00	2.40	2.80	3.60	4.40	5.20	6.00	6.75	7.55	8.30	9.10	9.90	11.45	13.00	2770
9	1.80	2.10	2.40	2.90	3.35	4.30	5.30	6.25	7.25	8.20	9.15	10.10	11.10	12.05	14.00	15.90	2460
10	2.15	2.50	2.85	3.45	4.00	5.15	6.30	7.45	8.60	9.75	10.90	12.00	13.20	14.35	16.60	18.90	2210
12	2.65	3.10	3.70	4.50	5.25	6.80	8.40	9.95	11.50	13.05	14.60	16.20	17.75	19.30	22.45	25.50	1850
14			5.05	6.05	7.00	9.00	11.00	13.00	15.00	16.95	18.95	20.95	22.95	24.90	29.90	32.80	1580
16					9.10	11.70	14.30	16.85	19.95	22.00	24.55	27.15	29.70	32.30	37.40	42.50	1380
18						14.45	17.70	21.00	24.25	27.50	30.75	34.00	37.25	40.50	47.00	53.50	1230
20							17.50	21.55	25.55	29.60	33.70	37.80	41.90	45.95	50.00	66.00	1100

The wheels are made with a vitrified bond and pressed under hydraulic pressure. Those over three inches in diameter are turned up after firing. The same numbers are used to designate the degrees of fineness, as are used with Emery, and the wheels are made in seven degrees of hardness, marked SSS, SS, S, M, H, HH, HHH, from extremely soft to extremely hard. In ordering, state diameter, thickness, hole, number and hardness.

Hones, Slabs, Files.

CUT THIS OUT.

# THE CARBORUNDUM CO.

WORKS: MONONGAHELA, PA., AND NIAGARA FALLS, N. Y.

**DIAMONDS.**  
**Wm. S. Hedges & Co.,**  
 IMPORTERS OF  
**Diamonds and Precious Stones.**  
**DIAMOND JEWELRY.**  
**170 Broadway, New York.**  
 22 Holborn Viaduct, London.

**Alfred H. Smith & Co.,**

IMPORTERS

DIAMONDS

AND

PRECIOUS STONES,

**182 BROADWAY, COR. JOHN STREET,**

NEW YORK.

Venetian Building. **34 & 36 Washington St.**

CHICAGO, ILL.

**HENRY FERA,**

IMPORTER AND CUTTER OF

**DIAMONDS**

PRESCOTT BUILDING,

65 Nassau St. cor. John NEW YORK

FACTORY

60 Fulton St., NEW YORK.

Cutting for the Trade a Specialty.

**HERMAN KOHLBUSCH, SR.**

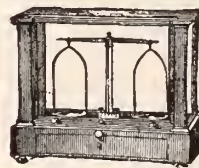

Established 1859  
 Manufacturer of  
 FINE BALANCES  
 AND WEIGHTS for  
 every purpose  
 where accuracy is  
 required. 59 Nas-  
 sau Street, cor.  
 Malden La. N. Y.

Repairs (any make)  
 promptly made.



**SCHULZ & RUDOLPH,**

IMPORTERS AND CUTTERS OF

**DIAMONDS AND OTHER PRECIOUS STONES,**

(Successors to JOHN E. HYDE'S SONS.)

Sole Agents for **The Celebrated Jules Jurgensen Watches.**

28 JOHN ST. and 65 NASSAU ST., NEW YORK.

**The Bowden Rings**

ARE COMPLETE IN VARIETY, CORRECT  
 IN QUALITY AND PERFECT IN FINISH.  
 WE MAKE EVERY VARIETY OF FINGER  
 RINGS.

**J. B. BOWDEN & Co.,**

3 MAIDEN LANE,

NEW YORK.

The finest, perhaps, of the larger mazers is one at Armourers' Hall, London. It is nearly a foot in diameter, and of considerable depth; the rim and foot are of silver-gilt, and are united to each other by vertical bands, all the metal work being covered with inscriptions, from which it appears that it was repaired in 1579, the year of its hall-mark (1578-9), though the original bowl was older, having been presented by Everard Frere, the first master of the Armourers' Company, after their incorporation in 1453. Within the bowl are the arms of the company, St. George and the Dragon, and a cross within a wreath. Another large mazer was exhibited by Rev. G. W. Braikenridge in 1862. This is known as "the Tokerys bowk," and is 9 $\frac{3}{8}$  inches in diameter, and 7 $\frac{3}{4}$  inches high. It is inscribed in Lombardic letters of the period, much resembling those of Mr. Franks' small mazer—"Be yow mere and glade and soo the Masters Tokerys do byde,"—an invitation to drink which no doubt has often been accepted. The words are divided by an ape, a dog, a pig, a stag, a huntsman, fruit or flower. The mount of the bowl is of the year 1534, but as usual the bowl itself seems older, while the foot bears the hall-marks proper for 1560-1. This foot is simply a fine tazza inverted and fastened beneath the mazer, from which it differs much in style, being quite Renaissance while the mazer is Gothic. Were this hybrid composition divided horizontally, two fine pieces of 16th century plate would be restored to their proper condition without injury to either.

(To be continued.)

**Duchess of Marlborough's Belt of Diamonds.**

[SPECIAL CABLE BY JULIAN RALPH]

LONDON, July 16.—[Copyrighted, 1896, by the New York Journal.]—Your society reporter here informs me that at a party at a Devonshire house the other day the display of jewels exceeded anything yet seen in London, but the Duchess of Marlborough easily led all the others.

The reporter says it was not her coronet that did it, though that was a trifle higher than those worn by most of the other peeresses present. Her unique attraction was a belt of diamonds, literally a belt, that at present is unapproachable.

**The New York Jewelers' Board of Trade Remove to Larger Quarters.**

The New York Jewelers' Board of Trade, having leased the plant and business of the Jewelers' Mercantile Agency, Ltd., find that their present quarters are not large enough for the consolidation of both offices, and for the carrying on of their business; therefore the New York Jewelers' Board of Trade have leased the handsome offices covering 1,700 square feet on the fourth floor of the Fahys building, 54 Maiden Lane, New York, and will remove from their present quarters, 68-70 Nassau St., in about two or three weeks, and at the same time the Jewelers' Mercantile

Agency, Ltd., 214-216 Broadway, Park Bank building, will remove to the said offices in the Fahys building.

On account of their removal, the New York Jewelers' Board of Trade offer for rent the present offices now occupied by the Jewelers' Mercantile Agency Ltd., and also their offices 68-70 Nassau St., twelfth floor. The last mentioned offices are light and airy, and desirable in every particular, especially for the carrying on of the jewelry and diamond business.

**First Outing of the Baltimore Jewelers' Club.**

The First Grand Annual Outing of the Jewelers' Club of Baltimore, Md., will be held at Ingram Hall, near Hanesville, Kent County Md., on Aug. 15th, 16th and 17th. The steamer leaves pier 6, Light St. wharf, Baltimore, Saturday, Aug. 15, at 1 o'clock P. M., returning to Baltimore Monday afternoon. For those desiring to return Sunday evening special arrangements will be made.

The outing will consist of driving, boating, bathing, dancing, etc., the total cost of which, including meals, lodgings, etc., will be \$8. There will be no extras. A letter of acceptance, inclosing \$5 as a guarantee, is requested by the committee, to be received not later than Aug. 5th. A number of members of the trade have signified their intention to be on hand. All communications in reference to this matter are to be sent to Frank I. Lochlin, care of Unger Bros., Newark, N. J., and Wm. F. Koch, care of The James R. Armiger Co., 31 E. Baltimore St., Baltimore, Md.

**Death of an Old-Time Chainmaker.**

PROVIDENCE, R. I., July 20.—Charles Peck, one of the oldest and best known residents of Pawtucket, died on the morning of July 16, at the age of 91 years. The greater part of his life was spent in the village. The deceased was born on March 31, 1805. After leaving school he lived in this city and learned the trade of a blacksmith. After a few years at this trade, he learned the jewelers' trade, and carried on a small business here as chainmaker for about 15 years. After this he returned to Pawtucket and opened a blacksmith shop. After a decade he moved again, and returned to the manufacturing jewelry business at his home. From 1870 to 1873 he occupied a farm on the line between Scituate and Gloucester, this being his last settled occupation.

**THE ADDRESS OF THE WESTERN SILVER METAL CO.**

BROOKLYN, N. Y., July 23, 1896.

Editor of THE JEWELERS' CIRCULAR:

We notice in your July 22d issue a query from the Webb C. Ball Co., Cleveland, O., asking for the address of the Western Silver Metal Co. The address of this concern is 203 Fifth Ave., Chicago, Ill.

Very truly yours,

J. R. CLARK,

General Manager, Self-Winding Clock Co.

ESTABLISHED 1840.

**RANDEL, BAREMORE & BILLINGS**

IMPORTERS OF

**DIAMONDS,**

AND OTHER PRECIOUS STONES.

**FINE PEARLS A SPECIALTY.**

MANUFACTURERS OF

**DIAMOND JEWELRY**

A Large Stock of Fine Mounted Goods Constantly on Hand.  
Goods Sent on Approval and Insured in Transit.

Diamonds Cut, Recut and Repaired.

58 Nassau Street,  
29 Maiden Lane,  
NEW YORK.

1 Tulp Straat,  
AMSTERDAM.

1 St. Andrew's St.,  
Holborn Circus,  
LONDON E. C.

ESTABLISHED 1841.



**CARTER, HASTINGS & HOWE,**

MANUFACTURERS OF

**GOLD JEWELRY,**

**15 MAIDEN LANE, NEW YORK.**

A. CARTER

C. E. HASTINGS,  
W. T. CARTER,

G. R. HOWE,  
W. T. COUGH

FACTORY, NEWARK, N. J.

**WOOD & HUGHES,**  
**STERLING SILVERWARE MANUFACTURERS**  
New York Agents for the Derby Silver Co.,  
**FINE QUADRUPLE PLATED WARE**  
No. 16 JOHN STREET, NEW YORK.  
206 Kearney St., San Francisco, Cal.  
**HASKELL & MUEGGE, Agents.**

**FERD. FUCHS & BROS.**  
**SILVERSMITHS.**  
MAKERS OF STERLING SILVERWARE,  
808-810 Greenwich St., - New York.

# \$100

## IN PRIZES

Awarded by The Jewelers' Circular Pub. Co.

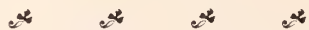

**PRIZE \$10**—For drawing and description of best Original Design for jewelry store window decoration. **PRIZE \$5** for second best.

**PRIZE \$10**—For the Photograph of the best displayed window in the jewelry trade. **PRIZE \$5** for second best.

**PRIZE \$10**—For the Photograph of the best arranged interior of a jewelry store and description of same. **PRIZE \$5** for second best.

**PRIZE \$15**—[Open only to employes] For the best essay on "How to Successfully Conduct a Jewelry Business" **PRIZE \$5** for second best.

**PRIZE \$15**—[Open to Travelers only] For the best essay on any topic he may select bearing upon the relations of the traveler to the principal and the trade at large.

**PRIZE \$10**—For the most effectively written advertisement, advertising a holiday line of the goods generally carried in a retail jewelry store.  
 **NOTE**:—No limit as to space ad. is to occupy.

**PRIZE \$10**—For the Best Design (drawing) for advertising a holiday stock of jewelry.  **NOTE**: No limit as to space design is to occupy.

**NOTE**:—All Photos and all Mss. sent in competition, to be the property of The Jewelers' Circular Pub. Co.

**NOTE**:—All Photos and all Mss. to be in the hands of the publishers not later than Sept. 1, 1896.

**NOTE**:—A competent jury will pass upon all matter sent in in the various contests, of which notice will be given hereafter.

All matter to be sent to

**The Jewelers' Circular Pub. Co.,**  
 189 Broadway, New York.

### The Assignment of Sexton Brothers.

The trade were surprised last week when they learned that the well-known firm of Sexton Bros., composed of Augustus W. and William L. Sexton, manufacturing jewelers, 41 and 96 Maiden Lane, New York, had assigned to Charles H. Zellers. The assignment was filed Wednesday, and gives preferences to the Mercantile National Bank and to the estate of the late Wm. Moir, for notes discounted and money due, the amount not being stated. A CIRCULAR reporter was informed that the total preferences were about \$7,000.

According to a statement of the assignee, the assignment was the result of bad business and was made to bridge over the next two months, which are among the dullest of the year in the jewelry trade. He could give no figures as to liabilities.

Augustus W. Sexton, one of the partners, said that there had been a gradual shrinkage of the assets due to the hard times and to poor business. He could not tell exactly what the firm's condition was, but roughly estimated the total liabilities at \$14,000, of which about one-half was for merchandise. The assets, he thought, were nominally worth about \$20,000. Work had already been commenced on the schedules, which would be filed as soon as completed. As soon as a definite statement of the firm's condition could be made a meeting of creditors would be called.

The firm of Sexton Bros. continued the business of Sexton Bros. & Washburn, who dissolved about two years ago, Geo. W. Washburn retiring. Sexton Bros. & Washburn were formed about 1887, by the consolidation of the firms of A. W. Sexton & Son and Sexton & Washburn. The elder A. W. Sexton was a member of the old firm of Baldwin, Sexton & Peterson.

### Meriden Industries Improving.

MERIDEN, Conn., July 21.—Of the factories that started their machinery yesterday Meriden Britannia Co. are running eight hours a day in all departments with about half their usual force. The Charles Parker Co. started up in the screw department, which was the only one not running. The Meriden Silver Plate Co. started their works yesterday in all departments. At Miller Brothers' Cutlery Co. the pen department started up yesterday on 10 hours' time, and other departments will probably start by the middle of the week. The Wilcox Silver Plate Co. will start running again next Monday.

**Separating Gold from Silver.**—The alloy is to be smelted and poured from a height into a vessel of cold water, to which a rotary motion is given, or else it is poured through a broom. By this means the metal is reduced to a fine granular condition. The metallic substance is then treated with nitric acid, and gently heated. Nitrate of silver is produced, which can be reduced by any of the ordinary methods, while metallic gold remains as black sediment, which must be washed and smelted.

**The Failure of Herman Oppenheimer & Co.**

KANSAS CITY, Mo., July 24.—Herman Oppenheimer & Co., wholesale and retail jewelers, 908 Walnut St., have made an assignment to secure debts amounting to \$25,000. A chattel mortgage was given to the Citizens' National Bank for \$15,516 on the jewelry, stock and fixtures. Afterwards a deed of trust was filed on a lot on the east side of Main St. between 2nd and 3d Sts. to Frank Brumback, trustee, to secure notes for \$3,300, given to H. L. Gross, Danville, Pa., and Louis Gross, Bloomsburgh, Pa.

A second chattel mortgage was filed after the first to secure a note of \$2,500 held by H. L. Gross and one to Louis Gross for \$800, and also to secure I. N. Ridge \$300 rent on storeroom. Besides these debts the firm owe about \$2,000 on merchandise accounts.

Mr. Oppenheimer lays the failure to the present stagnation of business, which has prevented the firm from realizing on their accounts. The stock will invoice \$60,000, which will more than secure all creditors. Mr. Oppenheimer has been in business in Kansas City 15 years and at his present location four years.

**Watch Inspection on the C. & O. and St. L. & San F. R. Rs.**

CHICAGO, Ill., July 25.—The second quarterly inspection of watches on the Chesapeake and Ohio and the St. Louis and San Francisco railways have been completed by J. W. Forsinger, general inspector, Columbus Memorial building, Chicago, with the following results:

CHESAPEAKE & OHIO.	
Watches inspected.....	926
Watches compared with standard time, weekly.....	743
Average number days run for rated watches.....	23
Average daily variation, in seconds for rated watches.....	6
Rejected as unsafe.....	1
ST. LOUIS AND SAN FRANCISCO.	
Watches examined.....	364
Watches compared weekly.....	263
Average days run for rated watches.....	21
Average daily variation, in seconds for rated watches.....	4

The reports show the watches on both lines to be in good condition.

**An Unwarranted Seizure of Optical Goods.**

A seizure of optical goods which proved to be an unwarranted one, was made by Special Inspectors Brown and Donohue from Samuel Druiff and Arthur Linton, passengers on the *Umbrina*, which arrived about a week ago. Druiff, who is a member of S. & S. Druiff, manufacturing opticians, 38 Maiden Lane, New York, and Linton, who is a salesman for the same firm, made their usual declarations at Quarantine, but on their arrival, despite their protests, were forced to submit to a search of their clothing and baggage. In Linton's effects were found a pair of marine glasses, a pair of opera glasses, 30 pairs of gold eyeglass frames, and two diamond studs. In Druiff's trunks and in a valise were found

**ANNOUNCEMENT.**

**Jules Monard of Geneva,**

manufacturer of watches, whose production is so well and favorably known to the American trade, obtained

**HIGHEST HONORS ON (8) 16 SIZE MOVEMENTS.**

HIS TOTAL EXHIBIT, all selected at random from the stock then ready for shipment to this market.

**A. WITTNAUER,**

SOLE AGENT FOR

**JULES MONARD GENEVA WATCHES,**

19 MAIDEN LANE, NEW YORK.

**THERE'S MONEY IN CHINA**

The WILLETS MFG. CO.'S (Trenton, N. J.)

**FULL LINE OF BELLEEK CHINA**

including Vases, Clocks, Chocolate and Tete-à-Tete Sets, Bouillons, Teas and Coffees, Etc., specially designed for the jewelry trade,

**IS THE KIND THAT SELLS.**

Handsome—Novel—Now on exhibition at N. Y. Office,

32-36 PARK PLACE,  
Rooms: 17, 18, 19 and 12.

**WICKE & PYE, Agents.**

**DORFLINGER'S**

**AMERICAN**

**CUT GLASS.**



915 BROADWAY  
36 MURRAY ST.  
NEW YORK.



**The STATIONERS' ENGRAVING CO.,**

98 TO 102 NASSAU STREET, NEW YORK.

MAKERS OF

WEDDING INVITATIONS, RECEPTION AND VISITING CARDS

of the Best Quality, which are offered to Jewelers of recognized standing only.

Trade Mark "SILVER WHITE," registered.

**ANY BOOK**

pertaining to the Jewelry, Horological, Optical or kindred Trades can be obtained through the Jewelers' Circular Publishing Co., 189 B'way, N. Y. Send for new catalogue, just issued. It is free.

24 gold eyeglass frames, 22 silver eyeglass frames, 71 pairs of steel eyeglass frames, 35 spectacle frames, two pairs of gold rimmed eyeglasses, 19 pairs ordinary eyeglasses, six pairs spectacles, seven gold eyeglass frames and three diamond studs. The total value of the property was estimated at \$1,000.

Linton and Druiff explained that all the dutiable goods had been declared, and that these were simply American samples of their own manufacture, which they were bringing back to this country. The studs and field glasses were personal property. Although they showed the American invoices for the goods, the inspectors insisted on seizing them. A protest was filed with the Collector, and referred to the Law Department of the Custom House, which resulted in a decision releasing the goods, which were returned to Mr. Druiff Wednesday.

A representative of the Law Department of the Custom House told a CIRCULAR reporter Saturday that all the seized goods had been returned because there was no cause for seizure. The inspectors thought there was a *prima facie* case of smuggling, but an investigation showed that the articles seized had been sent to London by S. & S. Druiff and, being American goods, were exempt from duty when brought back here. The studs, he said, were plainly the personal property of Messrs. Druiff and Linton, and should never have been seized.

#### Selzer Evaporates and Leaves Many Creditors.

The extent of the credit obtained by Isidor Selzer, a diamond dealer, formerly of 83 Nassau St., New York, who recently skipped out, became known at a conference of some of his creditors held Wednesday at the office of J. M. Lyon, 20 Maiden Lane. When it was discovered that Selzer with his family had de-

serted his office and also his home, at 28 E. 111th St., it was first believed that he left creditors for but a few hundred dollars. Investigation has since shown that he obtained goods valued at between \$5,000 and \$10,000. Selzer, a CIRCULAR reporter was informed, paid promptly for his goods until he had established a credit with most of the firms he victimized. From J. M. Lyon he obtained diamonds valued at about \$700; to L. M. Berinstein he owes about \$120 for jewelry; to Lyonce Langer is due \$185 for a pin obtained on memorandum. Among other large creditors are said to be Louis Berney, 257 Broome St.; Joseph Robinson, 12 Stanton St.; W. B. Barnard, 171 Park Row, and Ferd. Levy. Selzer is believed by many of his victims to have sailed for Europe.

Mr. Lyon stated that nothing had yet been done by the creditors toward recovering their goods and no proceedings could be taken until Selzer had been located.

#### Nels Johnson to Supply the Clock for the St. Joseph, Mich., Court House.

Nels Johnson, tower clock maker, Manistee, Mich., has secured the contract for a tower clock for the court house at St. Joseph, Mich. Mr. Johnson's bid was considerable higher than his competitors, but the committee awarded him the contract. The St. Joseph Register says: "Wednesday the bids were submitted for the new bell, new clock and illuminated dial. The bids submitted were the Seth Thomas Clock Co., Chicago, \$825; Howard Clock Co., Boston, \$910; Johnson Electric Service Co., Milwaukee and Detroit, \$839; Nels Johnson, Manistee, \$985. The bids were considered Wednesday afternoon. The bid for the county clock and bell was let to the Manistee man who represented no company, but was on the ground as an individual working for the job."

#### The Whiting Mfg. Co. to Furnish the "Oregon" Silver Service.

PORTLAND, Ore., July 20.—A \$5,000 silver service is to be presented by the citizens of Oregon to the United States battleship bearing that name, recently put in commission at San Francisco. A committee was appointed by the Governor of the State, and after a hot competition the design of the Whiting Mfg. Co., New York, represented by A. Feldenheimer, Portland, was accepted by the committee.

The service will be of Louis XIV. style, and will consist of 30 pieces. The committee consisted of citizens of high standing and integrity, and the award was made on a fair and square basis.

#### The Seattle Jewelers' Association After a Desperado.

SEATTLE, Wash., July 20.—The Jewelers' Association of Seattle have offered a reward of \$200, in addition to \$100 offered by the county, and \$500 offered by the Governor in behalf of the State, for the capture of the party who robbed and shot Nathan Phillips, a traveling jeweler. Mr. Phillips is recovering fast and will soon be able to assist in the prosecution of his assailant. The crime has been traced to one David Leroy, who has been shot at several times by the sheriff's posse during a hot pursuit, but has not yet been captured.

#### Made Social Calls and Committed Robbery at the Same Time.

Adolph Hermansohn, a young man 23 years old, was a prisoner in the Jefferson Market Police Court, New York, Thursday, charged with grand larceny by Stone Bros., wholesale jewelers, 535 Broadway. Hermansohn was one time employed by Stone Bros. for two years, but was discharged December, 1894.

Since his discharge articles of jewelry have been frequently missed, but suspicion never seems to have rested upon Hermansohn, who used to call frequently at the store, ostensibly to see some of the other clerks. He used to sneak down to the sub-cellar, hide and steal what articles of jewelry he could find. He was noticed going down to the cellar on Thursday afternoon, July 16th, and was found hiding behind some boxes. He was ordered out of the place and told not to enter the store again. Mr. Stone then thinking that his former clerk might have had something to do with the periodical thefts that had occurred, laid the matter before Captain O'Brien, of the Detective Bureau. Detectives learned that young Hermansohn lived at 93 8th St., and they at once began to shadow him.

Wednesday evening Hermansohn was arrested near his home, and the detectives then searched his room, where they found about \$150 worth of the stolen jewelry, and 15 pawn tickets for stolen articles of jewelry.

When arranged in court Thursday the prisoner confessed his guilt and told how he had committed the thefts. The exact amount of his stealings is not known. Magistrate Duell held him in \$2,500 bail.

"From Across the Pond."



Novelties

THE PICK OF THE EUROPEAN MARKETS.  
NUMEROUS ATTRACTIVE SELLERS.

Our Regular Line

UP TO ITS USUAL STANDARD.

HENRY FROEHLICH & CO.,

68 and 70 NASSAU STREET, N. Y.

GOLD MEDAL,  
PARIS EXPOSITION, 1889.

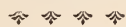

For Superior Cutting in Compe-  
tition with the World.

HIGHEST AND ONLY  
AWARDS.



For Scientific Cutting  
at Antwerp  
1885. Expositions. 1894.

# The Coetermans = Heinrichs = Keck

Diamond Cutting Company,

LEADING  
DIAMOND  
CUTTERS.

Cable and Telegraphic address, "RUBIS."

ANTWERP.

CINCINNATI.

KIMBERLY.

## Announcement.

WE call the attention of our customers, and trade in general, to the fact that our MR. HERMAN KECK has just returned from Europe with large purchases of original parcels of RIVER AND SILVER CAPE ROUGH DIAMONDS, which we are now cutting in our factory in our unrivalled style of cutting. These goods will be offered at our usual low prices. Buyers will find it to advantage to communicate with us before making purchases.

Our travelers will call, as heretofore, with complete stocks of loose and mounted goods.

SOLE AGENTS,  
THE HERMAN KECK MFG. CO.

PRESIDENTIAL CAMPAIGN BUTTONS, ETC.

PART II.

FINE PORCELAIN BUTTONS.

The campaign buttons of the O'Hara Waltham Dial Co., Waltham, Mass., are made of the finest belleek ware and the colors and gold are "burnt in" at a white heat in a kiln in just the same manner as in chinaware. These goods are something entirely new in construction and design, and are protected by the company. They make a number of other



PORCELAIN BUTTONS—O'HARA WALTHAM DIAL CO.

designs which apply to the campaign questions now being discussed. They have been induced to manufacture a button which was not an imitation of anything, and to catch that line of trade which would not wear the lurid or elaborately ornate designs. This company's buttons are decorated in 24-karat gold, fine silver and mineral colors in subdued shades, and while they are liked by those who wear louder patterns, they are not offensive to the good taste of cultured people. They are just what they are represented to be—porcelain—and in their illumination thought is given to harmony, outline, and the general fitness of things. The company's long experience in enamel and porcelain peculiarly fits them for the proper exploitation of such a line of work. Their buttons are very differ-

ent in material and execution from the cheap lines which are turned out by the thousands, and they do not pretend to compete with anything but achievements in their particular lines.

THE DAISY FREE COINAGE BUTTON.

This button is a correct representation of the field daisy which is the campaign flower of the 16 to 1 movement. The idea is complete and unique, 16 white or silver petals to 1 gold center making a perfect representation of a field daisy. The design won the \$150 prize given by John Wedderburn & Co., patent



DAISY FREE COINAGE BUTTON IRELAND & KAPPLER.

solicitors, Washington, D. C., for special merit. The button is controlled by Ireland & Kappler, 60 Corcoran building, Washington, D. C. The design speaks for itself. Its Jeffersonian simplicity will make it a popular campaign button among Democrats.

THE PAMPAS GRASS EMBLEM.

Chas. M. Robbins, Attleboro, Mass., manufacturer of jewelry novelties and specialties in various metals, has produced a number of campaign buttons and emblems as here illustrated. As may be seen these goods comprise a "Honest Money," a "Free Coinage," "Free Silver" and a "McKinley Hat" button, a McKinley-Hobart flag pin, an American flag pin and a Pampas Grass badge. The *raison d'être* of the pampas grass as an emblem is given in the following announcement issued June 19 last at St. Louis:

To the Republican Party of the United States: In recognition of the courtesy of Mrs. H. W. R. Stroug, of Los Angeles, Cal., in presenting to the Republican national convention, through its chairman and the chairman of each State, the adopted Republican emblem of 1892, made of California pampas plumes, the

only American product cultivated for the beautiful, I do hereby recommend to the party the use of this



CAMPAIGN EMBLEMS—CHAS. M. ROBBINS.

emblem, in red, white and blue pampas, mounted fan shape on a staff, for parades and interior decorations.

M. A. HANNA,  
Chairman.

"THAT SILVER PITCHFORK."

Tillman's pitchfork forms a speaking emblem for every silver man. The badge represents the "gold bugs" McKinley, Rothschild

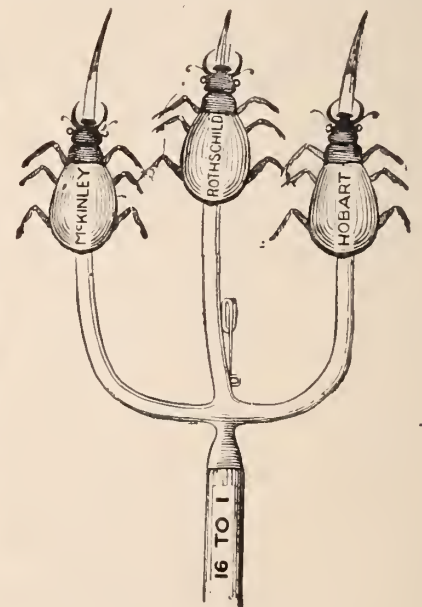

TILLMAN'S PITCHFORK—J. L. SIBLEY.

and Hobart, "all killed, just as the candidates were touching the 'money power' for campaign 'boodle.'" The badge is patented and sold by James L. Sibley, 39 W. Mitchell St., Atlanta, Ga. The illustration here is in enlarged size, the pin being about 3/4 x 1 1/2 inches, in dimensions.

Only makers of "Republican League" lapel buttons.	Republican lapel button.	McKinley button.	Free Silver lapel button. "16 to 1."	The Favorite Republican lapel button.
Hard Enamel.				Hard Enamel.
Also Democratic, Populist and Prohibition Buttons.				
<b>WILLIAMS &amp; PAYTON,</b> MAKERS OF JEWELRY, PROVIDENCE, R. I.				
New York Office: 176 BROADWAY.				
For Artistic, Original Campaign Buttons see our Line.				
Lapel buttons and Scarf pins	SEND FOR ILLUSTRATED CIRCULAR.			Lapel buttons and Scarf pins.



# THE WHITEHEAD & HOAG CO.

MAKERS OF

## ...Badges, Banners, Flags and Buttons,

### NEWARK, NEW JERSEY.

The largest exclusive badge and button business in the World. Write for special terms and discount, also catalogue of campaign badges, etc.



No. 10—Can also be had with single portrait of McKinley, and single portrait of Hobart. We also have this same style of badge with portraits of all other candidates.



No. 12—Can also be had with portraits of Bryan and Sewall similar to the McKinley and Hobart badge No. 10. Also with single portrait of Sewall.



No. 22



No. 20

PRICES: Jumbo Buttons No. 20 and 22, size, 1 1/4 inch diameter, Per doz, 50 cts. Per 100, \$3.00. Per 500, \$8.00. Per 1,000, \$20.00. Per 5,000, \$18.00 per 1,000.

We have above Jumbo buttons with single portraits of McKinley or Bryan.

PRICES: Badges Nos. 10 and 12 in quantities of 1 dozen and over, 8 cts. each. 100 and over, 7 cts. each. 500 and over, 6 cts. each. 1,000 and over, 6 cts. each. 5,000 and over, 5 cts. each.

No. 10.

No. 12.



No. 13



No. 14



No. 15



No. 16



No. 17



No. 18

PRICES: Pin Back Buttons Nos. 13, 14, 15, 16, 17, and 18, 3/8 inch diameter.

Per dozen, 30 cts.

Per 100, \$2.00.

Per 500, \$8.00.

Per 1000, \$15.00.

Per 5000, \$12.00 per 1000.

Also same style for Gold Bug.

We have the above buttons with single portraits of McKinley, Bryan, Sewall and Hobart. Also combination portraits of McKinley and Hobart, and Bryan and Sewall.



No. 23—Gold Bug.



No. 26—This is the smallest size campaign button made; has a rolled gold rim, and is especially intended for fine trade. Price, 10c. each, \$1.00 per dozen, or \$7.50 per 100. Can be had with portraits of all candidates.

No. 26



No. 24



No. 27—Prohibition party buttons with portrait of Joshua Levering. Price same as No. 13.

No. 27

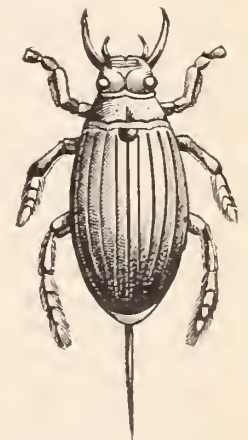

No. 25—Silver Bug.

PRICES: Gold Bugs, Silver Bugs and Draped Pin Flags Nos. 23, 24 and 25.

Per dozen, 50 cts.

Per 100, \$3.00.

Per 500, \$12.00.

Per 1000, \$20.00.

Per 5000, \$18.00 per 1000.

We will furnish buttons with the special portrait of any local candidate; in quantities of 1000 and over, at same prices. It will only be necessary to furnish us a photograph and we will reproduce it on the button or badge without extra charge.

WRITE FOR DISCOUNTS.

## THE BRYAN AND SEWALL BADGE AND BUTTONS.

Having already illustrated in the article in the issue of July 15th a number of Republican and Free Silver badges, buttons and emblems made by the Whitehead & Hoag Co., Newark, N. J., we here present illustrations of corre-



BRYAN & SEWALL BADGE—THE WHITEHEAD  
& HOAG CO.

sponding Democratic campaign jewelry. The Bryan and Sewall badge is similar in design to the McKinley and Hobart and can be had also with single Sewall portrait. The jumbo button here shown is very attractive, the 16 stars



BRYAN & SEWALL JUMBO BUTTON—THE  
WHITEHEAD & HOAG CO.

bearing upon the all-absorbing silver question. As may be seen in the firm's ad. on preceding page, the enormous line of campaign jewelry produced by them includes also single portrait buttons in various designs. The Whitehead & Hoag Co. are undoubtedly the largest exclusive badge and button concern in the world.

In the advertisement of the Ansonia Clock Co. in THE CIRCULAR of July 22d, the Chicago address of the company was erroneously given as 133-135 instead of 79-81 Wabash Ave.

The store of Mrs. L. A. Wood, Bay City, Mich., has been closed on nine chattel mortgages given to creditors for \$1,981.43. The mortgagees are J. F. Eddy, *et al.*, \$650; A. G. Wood, \$500; L. A. Prate, *et al.*, \$80; J. A. Purdy, \$46.31; Johnson Optical Co., \$90.12; H. Tupper, \$150; B. F. Black, \$175; A. J. Booth, \$80; S. Eichmeyer, \$80, and Amy Hoppcock, \$50.

## News Gleanings.

L. Gwin will move his jewelry stock from O'Neill to Laurel, Neb.

C. C. Berringer, Ogden, Utah, has assigned to E. T. Morton.

C. O. Moyer has returned from Middleburg, Pa., to Selinsgrove, Pa.

E. J. March will open a jewelry store on Main St., Burlington, Vt.

Mark Pilcher, of Mexico, Mo., has given a chattel mortgage for \$2,550.

D. J. Smith has gone out of the jewelry business in Fayette, Idaho.

F. B. Tiffany, oculist, Kansas City, Mo., has been sued on a note for \$250.

C. R. Reid has opened a jewelry store in the Trask building, Plant City, Fla.

D. S. Porter has opened a jewelry and watch repairing store in Avon Park, Fla.

Aug. Winkler, Poplar Bluffs, Mo., has given a trust deed for \$400 on real estate.

M. H. Goldwater has gone out of the jewelry business in Sheridan, Wyo.

Suit has been filed against W. H. Hadley, Ellendale, N. D., pending present suits.

O. H. Sleeper will erect a building in Exeter, N. H., and occupy it as a jewelry store.

Strow Brothers have succeeded to the jewelry business of John L. Strow, Fort Dodge, Ia.

A. D. Mermod, of Mermod & Teafe, jewelers, Canon City, Col., has given a chattel mortgage on cattle for \$500.

A. W. Brassler lost his stock of jewelry in the fire which nearly entirely destroyed the city of Malvern, Ark

Geo. B. Ludy, of Ludy & Taylor, Cedar Rapids, Ia., has been in Chicago, laying in a stock of goods for the Fall trade.

In a fire in Nashville, Tenn., some days ago, the jewelry store of W. B. Nimmerfall was affected; insurance, \$1,000.

C. F. Lauterback, Petersburg, Va., underwent a delicate surgical operation at the Home for the Sick a few days ago.

Huma Salzman, jeweler, Galveston, Tex., died on the morning of July 23, after a short illness. Mr. Salzman was well known in New York.

Isaac P. Walton, of Walton & Acklin, Tyrone, Pa., has gone to Cassadaga on Lake Chataqua, where he is spiritualizing in seance.

Willard J. Moore, Greenfield, Mass., will remove to Montpelier, Vt., about Aug. 1, and take the place of Arthur G. Mansur in A. G. Stone's jewelry store.

A burglar entered W. S. Noble's jewelry store, Drexel, Mo., some nights ago, and carried away about \$30 worth of watch chains. An entrance was forced through a window.

On July 1 Wilber I. Trafton entered upon his 35th year in the jewelry business in Portsmouth, N. H., having commenced July 1, 1862, in a small store in the original Franklin block.

The improvements to the store on Sycamore St., Petersburg, Va., formerly occupied by the Southern Express Co., are approaching completion. The store will be a very attractive

one. It will be occupied by Buchanan Brothers, jewelers.

A. Hube, a clerk in a jewelry store in South Bend, Ind., was sandbagged early in the morning of July 19, while on his way home, by two men, and robbed of his valuables. He lay in an unconscious condition for several hours before found. He will recover.

H. E. Parsons, a jeweler and furniture dealer in Readsboro, Vt., has lately developed healing powers and has within a few days become convinced that he has some power over rheumatism, nervous diseases, etc. His first patient was his wife, whom he is reported to have treated successfully.

George Pape's jewelry store, Limestone, Pa., was burglarized early last Sunday morning. The thieves effected entrance by forcing the front door with crowbars. The store is equipped with burglar alarms, which warned Mr. Pape of their presence. He rushed to the store in time to see the thieves taking their departure, and sent several shots after them, which went wide of the mark. The thieves succeeded in carrying off five watches.

## Connecticut.

The New Haven clock shop is now running in nearly all the departments on full time, after the usual Summer shut down.

The Phelps & Bartholomew Clock Co., Ansonia, started that portion of their shop which had been idle for three weeks on July 20th.

The Wilcox Silver Plate Co., Meriden, started up July 27th. A new floor has been placed on the glass room and various other improvements made.

Charles Parker, the veteran Meriden manufacturer, has just been re-elected for the forty-fifth time a director of the Meriden Savings bank and Edward Miller was re-elected a director of the same institution for the eighth time.

Paul Roessler, the oldest optician in Connecticut, having been in business in New Haven for over 40 years, has sailed with his daughter Pauline for Rotterdam. Mr. Roessler will summer with relatives at Berlin, while Miss Roessler will visit The Hague, Brussels, Antwerp, Ghent, Paris and London, returning late in the Fall.

The factories of Simpson, Hall, Miller & Co., Wallingford, resumed operations July 20th, after the customary shut down. There is considerable accumulation of orders resulting from a two weeks' idleness and the firm are looking forward to a fairly good Autumn business. The Watrous Mfg. Co. and Rodgers-Biggins Co. also resumed work that day.

The annual meeting of the stockholders of the Bristol Brass and Clock Co. was held at the office of the rolling mill July 22d. The directors elected are: J. R. Mitchell, James H. Welch, J. R. Holley, Bristol; George S. Brown, New York; Pierce N. Welch, Henry F. English, New Haven; Augustus H. Fenn. The officers chosen are: President, James Hart Welch; secretary and treasurer, Julian R. Holley; assistant treasurer, George S. Brown. The rolling department of the Bristol Brass and Clock Co. resumed on July 20th, after a shut down of three weeks.

## Our Traveling Representatives



Traveling representatives may consider these columns open for the publication of any news or items of interest regarding themselves or their colleagues.

The travelers in Kansas City last week were: S. S. Battin, Battin & Co.; Ned Lichtenstein, Leopold Weil & Co.; J. R. Theise, for I. M. Berinstein; M. Stein, S. & A. Borg-

zinner; L. H. Scott, M. F. Barger & Co.

John Finnerty is on his maiden trip down east for E. A. Cowan, Boston, Mass.

J. C. Donnell and E. H. Litch start out this week with new Fall samples from the Ripley-Howland Mfg. Co., Boston, Mass.

F. R. Horton, of Carter, Hastings & Howe, New York, was in St. Louis last week. Marc Weill, representing S. J. Son, diamond merchant, Chicago, was there the early part of the week.

The American Waltham Watch Co.'s missionaries, H. E. Duncan, J. M. Curley, D. H. Wells and F. O. Fuller, are home on their vacations, and will start out on their third quarter's trip about Aug. 1.

Travelers visiting Boston, Mass., during the week included: G. W. Read, William B. Kerr & Co.; J. D. Pettengill, Derby Silver Co.; Henry G. Thresher, Waite, Thresher Co.; E. A. Potter; C. E. Hancock, Hancock, Becker & Co.; Mr. Bliss, Bliss Bros.; J. M. Fisher.

Bookers of orders in Syracuse, N. Y., the past week included: C. B. Lawton, Dennison Mfg. Co.; J. Muhr, J. Muhr & Bro.; Jac. Engel, Lissauer & Co.; Emil Pick, Hammel, Riglander & Co.; Mr. Harris, J. Goldberg; L. B. Stevens, F. H. Noble & Co.; L. E. Waterman, Jr., L. E. Waterman Co.; Mr. Lamb, T. I. Smith & Co.

Travelers in Pittsburg, Pa., last week were: Fred H. England, Lissauer & Co.; F. C. Winship, T. B. Clark & Co.; A. W. Wagner, Leon J. Glaenzer & Co.; M. Traub, Falkenau, Oppenheimer & Co.; Percy Solomons, R. Hoehn Co.; Edwin L. Mumford, Waite, Thresher Co.; A. W. Atwater, Joseph Fahys & Co.; C. A. Marsh, C. A. Marsh & Co.; S. Arnstein, Arnstein Bros. & Co.; Leon Schwab, New Haven Clock Co.; Mr. Earl, Earl & Co.

For two weeks traveling salesmen have steered clear of Detroit, and the regular mid-summer stagnation has settled down on the trade in this city. There are signs of renewed activity, however, on the part of eastern houses, and the following will visit Detroit shortly: J. M. Morrow, American Watch Case Co., July 31; A. O. Waterman, Pairpoint Mfg. Co., Aug. 1; Norman Strauss, Strauss Brothers, Aug. 25; Mr. Porter, R. Wallace & Sons Mfg. Co. These passed through the city last week: Joseph Becker, Joseph Fahys & Co.; and Mr. Stanton, H. L. Stanton & Co.

The Commercial Travelers' Club, Springfield, Mass., are busy preparing for their picnic to be held on Aug. 7th, and have already arranged for a number of athletic events, including base ball, foot ball, tug-of-war, and races. The following committees have been appointed: Athletic, E. V. N. Ripley, chairman; George S. Bean, W. B. Deitz, A. S. Fuller, Charles Adams; reception, Frank D. Whitcomb, chairman; E. D. Ripley, B. E. Cady, John W. Reed, S. M. Hunt, A. H. Jennings, John A. Maxfield, C. W. Rannenberg, W. R. Harvey, B. J. Craig, H. K. Cooley, C. C. Gilbert, E. T. Houghton, J. G. Merrick, J. W. Pelton, C. P. Wilson, Lew Smith, E. H. Warner, C. N. Smith and F. G. Howe.

### Syracuse.

There is a movement on foot among the jobbers to close their establishments at noon on Saturdays through August.

On Monday morning Acting Police Justice Cady discharged Harry C. Flood, who was arrested on July 18th in connection with the affairs of the Interstate Importing and Manufacturing Co., on the charge of passing worthless paper, the cases having been settled by him and the plaintiffs withdrawing the warrant.

B. M. Polley, Norwood, was the victim of a peculiar robbery on July 17th between 10.30 and 11 o'clock P. M. Being obliged to leave his store for half an hour he left his goods in the cases and the lights turned on. During his absence an entrance was effected through a window in the rear and nearly the

entire stock of watches, chains, pins and small jewelry appropriated, the loss amounting to between \$1,000 and \$1,200. Some parties were arrested, but evidence not being sufficient to hold them they were discharged. There are suspicions as to the identity of the thief, but as yet there is no evidence to warrant his arrest. It is not known at this date whether Mr. Norwood will continue in business or not.

### Springfield, Mass.

O. W. Morey has bought the jewelry business of George N. Davis, Thompsonville.

F. A. Hubbard has moved from Dartmouth to Florida St. and in the future his wife's parents will make their home with him.

O. W. Bullock & Co. have purchased the stock and tools of the Union Needle Co. and moved them to their factory on Hillman St.

Dealers are trying to overcome depressed business conditions by advertising special sales, and are meeting with some degree of success. L. S. Stowe & Co. take a certain department at stated intervals and on that day make a special sale of the goods peculiar to that particular branch. Eldredge & Penny try to keep their whole stock moving evenly, and daily make a most attractive window display. F. A. Hubbard runs to special sales, and for the past week has been bearing down hard on wedding rings (which he advertises as an article that must not be forgotten at the altar), and wedding gifts in general. The other jewelers treat their entire stock alike.

## ....Campaign Buttons....

THE FINEST THING IN  
BUTTONS.



SOMETHING NEAT.

SMALL IN SIZE.

PERFECT IN TASTE.

MADE IN PORCELAIN.

Gold and Colors burnt in.

SEND 15 CENTS IN STAMPS FOR SAMPLE.

O'Hara-Waltham Dial Co., WALTHAM, MASS.

### Providence.

All communications for this column, addressed to P. O. Box 1093, Providence, R. I., will receive prompt attention.

James Glancy, Indianapolis, Ind., called upon the trade in this vicinity last week.

Charles F. Irons, of Irons & Russell, has returned from a cod fish excursion out of Provincetown, Mass.

Heimberger & Lind, manufacturers of jewelers' findings, are preparing to remove to the new Metcalf building about Aug. 1.

Robert Paterson has been granted a *nil dicit* judgment by the Supreme Court against William H. Richmond for damages and costs, damages being assessed at \$362.55.

The Bradley Novelty Co. is the name of a new concern recently started at 227 Eddy St., this city, for the manufacture of a general line of links, scarf pins, etc., in plate and enamel.

Eugene Garrett, a well known Pawtucket jeweler, fell from an electric car in that city Wednesday, and fractured his skull. He was removed to the Rhode Island Hospital, this city, where he died Thursday. He was 33 years of age, married, but had no children.

S. & B. Lederer, manufacturing jewelers, are planning for the construction of a seven-story building on Mathewson St. just west of Westminster St. It will be rented for retail stores and office use; the first two floors will be given up to the former and the remaining five divided into rooms for offices.

On Wednesday George H. Wood, Frank J. Bicknell and Joseph H. Potter, copartners of the recently assigned firm of Wood, Bicknell & Potter, re-entered the business world as a corporation known as the Wood-Bicknell-Potter Company. Their capital stock is not to exceed \$75,000, and the shares are valued at \$50 each.

### Boston.

Nathaniel L. Ripley, of the Ripley-Howland Mfg. Co., is in New York this week.

Fred. W. Graves, of the Boston office of Robbins, Appleton & Co., is receiving congratulations. The new arrival is a boy.

Carl Winther has removed from Bromfield St. to the Marlboro building on Washington St.

Among the buyers in town the past week were Fred. Gray for Harry Rayners, of Lowell, and W. A. England, of Worcester.

H. W. Becker, silverware buyer for George H. Richards, Jr. & Co., has purchased a fine estate in the suburbs of Reading for his future residence.

J. K. Ailman, optician, now at 6 Bromfield St., has taken new quarters at 27 Bromfield St., to which the establishment will be moved Aug. 1.

H. M. Kimports, 12 Washington St., has assigned to Charles F. Morrill. His liabilities are about \$20,000, and the assets, although ample to meet the indebtedness, are in part in leases and bills receivable, on which it is impossible to realize immediately.

It has been decided to build a fireproof

manufactory for the J. W. Tufts establishment on the Congress St. site as previously reported in THE CIRCULAR. This will be the first fireproof factory building in Boston, and the saving in insurance rates will be considerable annually.

The E. Howard Watch and Clock Co. have contracts to equip the magnificent new Tremont building, on the site of the old Tremont House, in this city, with watchman's clocks; also the Museum of Art, in Springfield, Mass., and will furnish two fine tower clocks for Trinity Court, the handsome Back Bay structure in process of erection for the Eben D. Jordan estate in Boston.

Henry Cowan has added to his establishment the next floor, with speaking tube and improved connections. This addition comprises a branch which is conducted under the name of Golden Lathe Repairing Co. A. A. Schaeppi, formerly manager of the material department of Geo. H. Kettmann & Co., Louisville, Ky., has now charge of the same department in Mr. Cowan's establishment. W. H. Everton, formerly in the material department, is now traveling for Mr. Cowan on the road.

### Pittsburgh.

W. W. Wattles is taking a vacation at Niagara Falls.

Herman Cerf, of M. Bonn & Co., has gone west on a business trip.

L. Evans was sold out by landlord's warrant on July 22.

Gillespie Bros. will open their jewelry store in the new Park building, Fifth Ave., on Aug. 15.

Mr. McBirney, formerly one of Heeren Bros. & Co's. traveling corps, is now on the road for Goddard, Hill & Co.

Philip Bauman, buyer for Heeren Bros. & Co., is lying dangerously ill at his home in Allegheny City.

S. Frank, one of the late arrivals among the trade on Fifth Ave., was closed out last week by the sheriff.

Charles W. Wattles returned last week from an extensive tour of the west. J. Harvey Wattles is at Mt. Clemens.

The silver wedding anniversary of Mr. and Mrs. William Heeren was celebrated on Thursday last at their home on Center Ave. and Neville St., East End.

Visiting jewelers in the city were: W. F. Hasinger, Blairsville, Pa.; Mr. and Mrs. H. H. Weylman, Kittanning, Pa., en route to Atlantic City; Paul Rudert, Tarentum, Pa.; Harry Janowitz, Johnstown, Pa.

Mrs. William McKinley has been presented with a novel portrait of her husband, a tin etching framed with tin. The tribute was planned by McKeesport friends, and the etching was done by William Heeren, this city. The portrait is a life-size of the large McKinley lithographs, 20x28 inches. The sheet of tin on which Mr. Heeren has etched the portrait was ordered by Mr. McKinley in McKeesport at the time of the McKeesport centennial celebration.

Harry Walker, watchmaker and jeweler, is missing from his place of business at Etna,

and all efforts on the part of his friends have failed to find the least trace of him. Walker is an Englishman, of about 30 years of age, has coal black hair and mustache, and weighs about 160 lbs. He had been in Etna some years, and had built up a good business. Inquiry in Etna developed nothing wrong in a financial or any other way, and his mysterious disappearance is the cause of considerable comment.

Flim-flammers evidently have marked Pittsburgh as their "very own" and have dubbed the jewelers as "easy." Two weeks ago George Cohen was victimized and last week, a man with two \$300 drafts bearing a prominent name, victimized two Smithfield St. jewelers of two \$150 diamonds, getting from each jeweler \$150 in change. A telephone message to the bank had, in each case, assured the jeweler the name was good, but the drafts were forgeries. A short time ago, another prominent Smithfield St. jeweler was swindled with a \$50 confederate note.

### Philadelphia.

Jacob Steiner, Troy, N. Y., has sold out.

C. C. Beringer, Ogden, Utah, has assigned.

Strow Bros. succeeds John L. Strow in business at Fort Dodge, Ia.

Edwin M. Flye, Holbrook, Mass., has mortgaged real estate for \$1,000.

The store of C. H. Aughenbaugh, Narrisburg, Pa., is in the sheriff's possession.

W. Robson, Thedford, Ont., has gone out of jewelry business.

James H. Kelly, with the Bailey, Banks & Biddle Co. has returned from Europe.

President Sackett, of the Jewelers' Club, was in Boston several days the past week.

Albert H. Rose, representing Durand & Co., was in town last week.

Charles Diesinger has taken his family to Atlantic City for the remainder of the summer.

I. S. Mitchell has vacated the premises at 4 S. 8th St. and now occupies more elaborate quarters at 836 Chestnut St. The establishment on 8th St. will be changed in connection with a clothing house building improvement at the south-west corner of 8th and Market Sts., so that Mr. Mitchell was obliged to seek new quarters when his lease expired.

"The Human Eye and How to Correct its Defects by Properly Fitting Glasses" is the title of a publication just issued by Queen & Co. The work is published in 10 chapters and is intended for the use of opticians and others who sell spectacles. It contains 30 illustrative cases and over 50 illustrations. The anatomy of the human eye and physiological optics are discussed at length on scientific principles. Lenses, testing the sight, defects of sight, hyperopia or far sight, myopia or near sight, astigmatism, general plan for testing the eyes for glasses, muscular insufficiencies, optical prisms and other subjects are also considered by the author.

# The Jewelers' Circular AND HOROLOGICAL REVIEW.

PUBLISHED EVERY WEDNESDAY BY  
**THE JEWELERS' CIRCULAR PUB'G CO.,**  
189 BROADWAY, NEW YORK CITY.

A JOURNAL DEVOTED TO THE INTERESTS OF JEWELERS, WATCHMAKERS, SILVERSMITHS, ELECTRO-PLATE MANUFACTURERS, AND ALL ENGAGED IN KINDRED BRANCHES OF INDUSTRY.

Member of the American Trade Press Association.

Our Editorial columns will contain our own opinions only, and we shall present in other columns only what we consider of interest or value to our readers. Advertising matter will not be printed as news.

Advertising rates in THE CIRCULAR are lower, considering the number of tradesmen reached by its large circulation, than in any other jewelry journal.

Notices of changes in standing advertisements must be received one week in advance; new matter can be received up to Monday.

## INFORMATION FOR SUBSCRIBERS.

### Terms of Subscription, Postage Prepaid.

	PER ANNUM.
United States and Canada. . . . .	\$2.00
Foreign Countries in Postal Union, . . . . .	4.00
Single Copies. . . . .	.10

New subscribers can commence at any time.

Payments for THE CIRCULAR when sent by mail, should be made in a Post-Office Money Order, Bank Check or Draft, or an Express Money Order or Registered Letter. All postmasters are required to register letters whenever requested to do so.

Pay money only to authorized collectors having proper credentials.

**Returning your paper.** Returning your paper will not enable us to discontinue it, as we cannot find your name on our books unless your address is given.

**Changing Address.** In changing address always give the old as well as the new one. Your name cannot be found on our books unless this is done.

**Discontinuances.** We will continue to send papers until there is a specific order to stop, in connection with which all arrearages must be paid; but such an order can be given at any time, to take effect at or after the expiration of the subscription. All such orders will be promptly acknowledged by mail.

**Liability.** The Courts have decided that all subscribers to Journals are responsible until arrearages are paid in full and an order to discontinue has been received by the publisher.

## THE JEWELERS' CIRCULAR IN EUROPE.

Among the Places in Europe where THE JEWELERS' CIRCULAR is on file are the following:

- LONDON**—First Ave. Hotel, Holborn, E. C.; Holborn Viaduct Hotel, Royal Hotel.
- PARIS**—Hotel de L'Athéné, Rue Scribe.
- BERLIN**—Deutsche Uhrmacher Zeitung, Jager-Strasse, 73.
- GENEVA**—Journal Suisse D'Horlogerie.
- AMSTERDAM**—Continental Club, Hotel Amstel.
- ANTWERP**—Diamond Club, Rue de Pelican.

Vol. XXXII. July 29, 1896. No. 26.

Every line of reading matter in THE JEWELERS' CIRCULAR, with the exception of the few brief extracts from exchanges, always properly credited, is written exclusively for this journal. Each issue of THE JEWELERS' CIRCULAR is copyrighted. Permission to quote is extended to other publications, if such quotations are properly credited.

**\$100** WHILE the announcement on page 8, of this issue of THE CIRCULAR, of the \$100 in prizes to be awarded by The Jewelers' Circular Pub. Co., tells practically the whole story, it may be advisable to give prospective competitors some additional hints.

**Prize 1.**—As to the drawing and description of the best original design for jewelry store window decoration, it must be borne in mind that the draughtsmanship will not be considered as an element, but that the three essential features are that the design shall be original, that it shall be appropriate for jewelry stores, and that it shall when materialized make an attractive window. It is absolutely necessary that the drawing convey the ideas of the designer. It is also desirable that the drawing be in ink.

**Prize 2.**—As to the photograph of the best displayed window in the jewelry trade, we will say that there is no limit placed as to the size of the photograph and that the photographer's ability will not govern the selection, though it is desirable that the photograph be such that the details of the arrangement are apparent.

**Prize 3.**—The suggestions set forth in the foregoing paragraph apply with equal force to the photograph of the best arranged interior of a jewelry store and description of same. If the photograph does not show all the departments of the store, the competitor may submit a comprehensive series of photographs if he so elects.

**Prize 4.**—As to the fourth competition, an essay on "How to Successfully Conduct a Jewelry Store," the competitor is not limited to any number of words or to any system of treatment. This competition is a fine opportunity for ambitious employes to crystallize into printed words their convictions as to the most advantageous methods for conducting a jewelry business, methods which by reason of the narrow-mindedness or martinetism of their employers, are not given expression.

**Prize 5.**—The traveler is almost universally considered a poor business man. He is looked upon, perhaps because he regards himself in a similar light, as a selling machine and to be practically void of business acumen, judgment and executive ability. He is usually a "good talker," but as a writer he does not shine, though Philip H. Welch, a one-time commercial traveler, was one of the brightest of American literary humorists. This competition gives the traveler an opportunity of proving himself capable of handling effectively some vital question bearing upon the relationship of the traveler to the firm and the trade. The field for essays is extensive: Reminiscences of the road, the past, present and future status of the traveler, the evolution of the traveling salesman, the traveler as a commercial force, the essentials of a successful salesman, argument against the submitting to the firm of itemized account of expenses, the advantages of fraternal organizations, the traveler and the hotel, the traveler as a man (should he marry?), the traveler's home, condemnation of the use of the word "draughtsman;" these and

many more may afford hints for subjects to be treated.

**Prize 6.**—He who would compete for the prize for the most effectively written advertisement advertising a jeweler's holiday stock, should sketch and write his suggestion on a single sheet of paper; he should lay out the matter as he thinks it would be most effective when set, and might specify styles of type by submitting clippings. If he considers the addition of an illustration or of illustrations effective, he should draw to the best of his ability the devices suggested, or carefully give details as to their character.

**Prize 7.**—The conditions as to the competition for the best design (drawing) for a jeweler's holiday ad. are essentially the same as those embodied in the first competition. The draughtsmanship will play little or no part, the characteristics of the successful design being that it possesses the most originality, appropriateness and attractiveness.

We would be pleased if competitors who propose to send MSS. will write on only one side of the paper.

## Diamond Mining **A** VERY hazy knowledge exists in the minds of the jewelers and

in Brazil. diamond dealers as to the conditions and prospects of the Brazilian diamond mines. The latest official information respecting these diamondiferous fields will, therefore, prove of general interest. Under date of Dec. 14, 1895, R. P. McDaniel, consul at Bahia, Brazil, submitted the following report to the Department of State:

"There is a great difference in the opinion of men who have had experience in diamond digging in this State. Some contend that the industry is in its infancy, that there has been only surface mining in the most primitive way, and that when mining is done scientifically, diamonds will be found in large, paying quantities; while others argue that the cream has been taken and only the 'skim-milk' remains. The principal or most important fields that have been worked are on the Serra (mountain) das Lavras Diamantinas and Serra da Sincora. Near the mines are the towns Lencoes and Andarahy, at which places there are lapidaries who cut many of the stones. In the above named mountains are the headwaters of the River Paraguassu. In the deep pools of this river, at the foot of the mountains, the miners dive to the bottom and bring up diamonds. Recently an American imported some diving suits for his men. He tells me that when the water is low in the river, he anchors a boat, sends his divers down, and fills the boat with earth from the bottom, then washes it to get the diamonds and carbon. A few months ago, a carbon was found at Roncardor, near Lencoes, which weighed over 3,000 karats, and was sold here for about \$25,000 and shipped to Europe. On the Serra Itaraça, near Salobre, in the southern part of the State, are found the finest diamonds. These are among the oldest and most important fields, and they are still being worked. Diamonds and carbon have been found at sev-

eral other places in the State, but not developed. I have been informed that an English company was organized with a large capital and modern machinery for the purpose of mining, on an extensive scale, for carbon, but decided only a few days ago to postpone the enterprise indefinitely on account of the unsettled state of affairs."

**FREE SILVER COINAGE WOULD CAUSE PERMANENT DISASTER TO THE SILVERWARE INDUSTRY.**

MIDDLETOWN, CONN., July 23d, 1896.

Editor of THE JEWELERS' CIRCULAR:

All our dollars should have equal value in the markets of the world, i. e., equal purchasing power.

If silver goes to \$1.20 an ounce and stays there, silverware and fine-plated ware would advance nominally and temporarily, but I think it would be permanently disastrous.

I don't know any way to make a common article like silver equal in value to a rare article like gold by fiat or otherwise.

Yours truly,

G. H. HULBERT,

Middletown Plate Co.

Buschmeyer & Seng, Louisville, Ky., have dissolve by mutual consent, Louis C. Seng retiring. Mr. Buschmeyer will continue the business as manufacturing jeweler at the old stand, 342 W. Market St. It is rumored that Mr. Seng will buy out John M. Reister, a manufacturer on Jefferson St., but nothing definite is known about the matter.



**Fall Season  
1896.**



WE take pleasure in announcing to the Jewelry trade that our NEW LINE of popular-priced and high-grade Pocketbooks, Chatelaine Bags, Ladies' Belts, etc.,

is now ready for the coming season. We have made special efforts in getting out new designs of above goods, comprising the very latest leathers, as well as Real Seal, Alligator, Lizard, etc., etc., in various new and fashionable shades. We have paid particular attention to Sterling Silver Mountings and will show a very exclusive line in these goods worthy of inspection.

**P. W. LAMBERT & CO.**  
64 & 66 Lispenard St., N. Y.



**New York Notes.**

E. H. Proudman, manufacturer of jewelry cases, has moved from 42 Maiden Lane to 36 Maiden Lane.

E. Aug. Neresheimer, of E. Aug. Neresheimer & Co., sailed for Europe Wednesday on the *St. Paul*.

A judgment against Herman J. Dietz for \$566.01 has been entered by B. Berman and others.

A. Peabody, diamond importer, New York, has applied for membership in the New York Jewelers' Board of Trade.

Wm. J. Hayden, with Rogers & Bro., 16 Cortlandt St., returned on the *Lucania* Friday, from an eight weeks' trip through Europe.

A cablegram was received in New York last week from Geneva announcing the results of the international watch *concours*. The highest award or first prize was received by Vacheron & Constantin, whose New York agent is Edmond E. Robert, 3 Maiden Lane.

The Fisher Electric Clock Co., of New York, have been incorporated to manufacture electric clocks, with a capital of \$100,000. The directors are James G. White, Frank L. Sheldon and Edw. J. Righter, New York, J. E. Ewing, Philadelphia, and James M. Wakeman, East Orange, N. J.

Creditors of E. A. Thrall, late of 3 Maiden Lane, are now receiving full payment on their claims. Assignee Ludeke recently distributed a dividend of 50 per cent. cash, and another dividend of the same amount is now paid to the creditors. There is a residu-  
merchandise, but to what amount in val-  
assignee could not state.

Jacob Richter, who described himself as a diamond setter 33 years old, was remanded in the Avenue Police Court, Brooklyn, last week to be examined on three charges of grand larceny. Mrs. Rose Chronegk, of 154 Broadway, the complainant, alleged that on March 2 she gave the prisoner, to be cleaned, all her diamonds and jewelry, valued at over \$500. Some of the jewelry, Mrs. Chronegk swore, Gerichte returned with pieces of glass instead of diamond settings, and the rest he declared he had found of no value and threw away.

The Boston police last week sent word to this city to look for C. E. Price, alias Holland, wanted in that city for swindling. Friday George Kohleppi, said to be a jeweler of 30 W. 29th St., called at the W. 30th St. station and said he had run across Holland. Mr. Kohleppi said that a few days ago Holland had come to him representing himself to be a member of a collecting agency, and saying that he had been authorized to collect the money due by Kohleppi to one Olson. Kohleppi paid a part of the money to the stranger, and also agreed to make a second payment, when Holland was to meet him at the Hotel Metropole. In the meantime he communicated with the stranger and had been told that Holland had fled to New York City from him and was hiding in New York. The Boston police. Detective Walsh we  
Hotel Metropole with

Kohleppi Friday and waited for Holland. Holland arrived at the appointed time and was captured after a chase. He was locked up.

**Last Week's Arrivals.**

**THE CIRCULAR has perfected arrangements for obtaining the names and hotel addresses of all the latest buyers visiting New York, and each day posts in its office, 189 Broadway, a bulletin which every member of the trade is cordially invited to copy.**

The following out-of-town dealers were registered in New York during the past week: L. Hausman, New Orleans, La., Marlborough H.; W. W. Frederick, jewelry buyer for Posner Bros., Baltimore, Md., Marlborough H.; G. White, jewelry buyer for G. White & Co., Des Moines, Ia., 63 Leonard St.; H. Frank, Natchez, Miss., 22 Howard St.; G. W. Banks, Philadelphia, Pa., Murray Hill H.; I. Metzgerberg, Chicago, Ill., Astor H.; W. Bausch, Rochester, N. Y., Murray Hill H.; E. Sickles, Philadelphia, Pa., Astor H.; G. Grant, Baltimore, Md., Broadway Central H.; D. F. Baxter, Minneapolis, Minn., Albert H.; C. Hadenfeldt, San Francisco, Cal., Astor H.; C. B. Safford, Kingston, Ont., Sturtevant H.; C. E. Fisher, jewelry buyer for W. Donalson & Co., Minneapolis, Minn., 415 Broadway; E. A. Rich, Chicago, Ill., Murray Hill H.; W. H. Glenny, Buffalo, N. Y., Murray Hill H.; R. Birtwistle, jewelry buyer for Gladding & Co., Providence, R. I., Albert H.; D. S. Pratt, Boston, Mass., Park Ave. H.; Miss L. Major, jewelry buyer for A. Lisner, Washington, D. C., Metropole H.; L. Heller, Chicago, Ill., Astor H.; A. Zugsmith, Philadelphia, Pa., Broadway Central H.

**Monard Watches Honored.**

The announcement on another page concerning the award made to Jules Monard, of Geneva, Switzerland, at the International Rating Competition of the Geneva Observatory will, no doubt, be read with interest by the firm's many friends in this country. The eight movements were the total number entered in the contest, and all were taken at random from the lot then ready for shipment to this market.

The fact that all, without exception, passed the test successfully, although not specially rated for this purpose, as is often done, proves the absolute reliability of all watches of this celebrated make, and further bears out the claim that each movement leaving the Jules Monard factory is rated within the limits of the Geneva Observatory. This new award to the Jules Monard watches adds to the already long list of honors obtained at many of the principal exhibitions by the several brands of Swiss watches imported by A. Wittnauer, 9 Maiden Lane, New York.

Ezra F. Bowman & Co., Lancaster, Pa., announce that they will in the future sell at retail. They have also established a repairing department.

## Special Notices.

Rates 75c. per insertion for notices not exceeding 3 lines (25 words); additional words 2 cents each. If answers are to be forwarded, postage stamps must be enclosed. Two insertions, 15 per cent. off; three insertions, 20 per cent. off; four insertions or more, 25 per cent. off. Payable strictly in advance. Display cards on this page will be charged at \$2.00 per inch for first insertion, subject to same discount as above for subsequent insertions.

Under the heading of **Situations Wanted** on this page advertisements will be inserted for **One Cent a Word** each insertion, no discount. This offer refers to **Situations Wanted only**. Payable strictly in advance. If answers are to be forwarded, postage must be enclosed.

## Situations Wanted.

Notices under this heading **ONLY** are charged at one cent a word, payable strictly in advance. If answer are to be forwarded, postage must be enclosed.

**WANTED.**—About September 1st, position as optician; A1 reference. Address Ferdinand, care JEWELERS' CIRCULAR.

**A YOUNG MAN**, aged 23, desires a position as watchmaker and plain engraver; good salesman. Address M., 10 Ralph Ave., Brooklyn, N. Y.

**POSITION**, by first-class watch and jewelry repairer; also A1 salesman; 10 years' experience at bench. Address C. E. Norton, Monona, Iowa.

**A YOUNG MAN**, 21 years of age wants a position; can do watch and clock work and jewelry repairing; 5 years' experience. Address W. A. Willmot, Salem, N. J.

**A MAN** of unquestioned ability in the watch, diamond and jewelry line, wholesale and manufacturing will be open for an engagement after Aug. 1st. Address, with particulars, Regulate, care JEWELERS' CIRCULAR.

**TRAVELING SALESMAN** of 15 years' experience with established trade in Illinois, Michigan Wisconsin and Minnesota will negotiate with good manufacturer or jobber of jewelry to carry his line on commission or salary; best of references. Address E. M. B. care JEWELERS' CIRCULAR.

## Help Wanted.

**WANTED.**—An entry clerk by a wholesale watch and jewelry house; one with some knowledge of the business preferred. Address Box 531, N. Y. P. O.

**WANTED.**—A first-class watchmaker; one having his own tools. Address, with references, stating salary expected, Brooklyn, care JEWELERS' CIRCULAR.

**WANTED.**—Practical jeweler and engraver for a retail store in New Haven, Conn. Write, stating salary desired; also references, to P. O. Box 601, New York City.

**WANTED.**—A reliable, all-round man; watchmaker, jeweler and engraver to go to North Carolina; pleasant, permanent position to right man. Address R., care JEWELERS' CIRCULAR.

**WANTED.**—Experienced traveling salesman to handle best American line of spectacles through New York State and the East. Address Optics, care JEWELERS' CIRCULAR.

**WANTED.**—First class salesman and window dresser, one having knowledge of engraving preferred; permanent position; I employ 8 people all the year round; state salary. B. E. Arons, jeweler, Pittsburgh, Pa.

**WATCHMAKER WANTED** one accustomed to trade work; must be good workman of steady habits. Answer, giving references and stating salary expected. Edwards & Sloane Jewelry Co., 614 Keith and Perry building, Kansas City, Mo.

**WANTED.**—A salesman with established retail trade in New York, New Jersey, Pennsylvania and Ohio, to represent a manufacturer's line of high grade rolled plate chains, as a side line on commission. Address Lock Box 561, Attleboro, Mass.

## Business Opportunities.

**FOR SALE** in Philadelphia, a desirable business in a fine locality; clean stock about \$5,000, which can be reduced if desired; walnut fixtures, fine regulator, safes, etc.; good run of work; established 12 years. Address O. E., care JEWELERS' CIRCULAR.

**\$650 00 SPOT CASH** buys fixtures, material and optical goods of leading jewelry and optical store; established 15 years; western New York; bench work \$1,500 per year; only optician; will sell any other part of stock if desired. Address J. O., care JEWELERS' CIRCULAR.

## FOR RENT.

Large Office,  
5th Floor - - **Corbin Building.**

Will let very low for  
Three Years.

APPLY, - - -

**JOSEPH FAHYS & CO.,**

NO. 54 MAIDEN LANE, N. Y.

**IF YOU WANT A POSITION  
YOU NEED A SALESMAN  
YOU NEED A WORKMAN  
YOU DESIRE TO EXCHANGE  
YOU WANT A PARTNER  
YOU WISH TO SELL OUT  
YOU HAVE TOOLS TO SELL  
YOU HAVE A PLACE TO LET  
YOU WANT ANYTHING**

USE THE

**SPECIAL NOTICE PAGE**

OF THE

**JEWELERS' CIRCULAR,**

Published Every Wednesday

Send for  
**New Catalogue  
of 200 Books**

pertaining to the Jewelry, Watchmaking, Assaying, Engraving, Optical and Kindred lines, published or for sale by the Jewelers' Circular Publishing Co. The only complete Catalogue published for these trades.

Sent Free upon Application.

**The Jewelers' Circular Pub. Co.,**

189 BROADWAY, N. Y.

## Death of John H. Shoemaker.

John H. Shoemaker, one of the best known and most popular manufacturing jewelers of Newark, N. J., died July 21st while taking a bath, at his home, 248 Mulberry St., Newark. An autopsy held by county physician Washington, showed that Mr. Shoemaker had been asphyxiated by gas.

When the body was found in the bathroom, which has no window, by Silas W. Pickering, the brother-in-law and business partner of Mr. Shoemaker, there was a very strong odor of gas in the room. The key of the gas jet had been turned about one-third on, so that sufficient gas had escaped to cause asphyxiation. It is the opinion of Mr. Shoemaker's family that, after taking a bath he was attacked with vertigo, from which he has been suffering lately, and in falling struck the key and opened it. Another theory is that the gas was burning and that in falling Mr. Shoemaker extinguished it. He was alone in the house at the time; his wife and married daughter, Mrs. Hawn, were at Long Branch.

The deceased was born in Dundee, N. Y., in 1840, and was a member of the widely scattered Shoemaker family of that district of New York. In early life he became associated with David Bedell, then in the oil business in Elmira, N. Y., whose daughter he afterward married. When Mr. Bedell moved to Newark in 1869, and went into the jewelry business, Mr. Shoemaker went with him and was employed by the firm of MacIntyre, Champenois & Bedell, which Mr. Bedell started.

Later Mr. Bedell withdrew and, with Mr. Shoemaker and another son-in-law, Silas W. Pickering, formed the firm of Shoemaker, Pickering & Co., who have continued ever since. Mr. Shoemaker became the manager and factory man of this firm, and soon rose into prominence in Newark's jewelry trade.

Mr. Shoemaker was one of the best known citizens of Newark outside of business circles. He was tall, of commanding presence and strikingly handsome. The deceased was of a cordial disposition and a lover of out-door sports, particularly base ball. In 1887, Mr. Shoemaker served as president of the Newark Base Ball League.

The funeral services were held at his residence Thursday, and the remains were interred at Newark.

## New Silverware Industry Projected in Oswego, N. Y.

OSWEGO, N. Y., July 24.—Daniel J. Toothill, who has been president and manager of the Oswego Silver Metal Co., has resigned, and with several Oswego business men is organizing a new company for the manufacture of all kinds of silverware. They have leased the old Doolittle mill property in E. 1st St. Mr. Toothill is succeeded by an executive committee of the board of directors consisting of James Dowdle, James D. Henderson and Charles A. Tanner.

Wm. B. Durgin's silverware factory, Concord, N. H., resumed work on full time and with a full force on Monday, July 20th.

"THE EMPIRE WESTWARD TAKES ITS WAY"

# WESTERN SUPPLEMENT OF THE JEWELERS' CIRCULAR

VOL. XXXII.

CHICAGO, WEDNESDAY, JULY 29, 1896.

NO. 26.

### Chicago Notes.

All communications in reference to the Chicago department of *The Jewelers' Circular*, addressed to S. Parlin, 270 Garfield Ave., Chicago, will receive immediate attention.

#### TRADE CONDITIONS.

With the exception that travelers for jobbing houses are preparing to go out there is little to note in trade. A few fair sales are being made to buyers from a distance, but they are not numerous, and nearby dealers are waiting. Despite election, jobbers look forward to a Fall business considerably in excess of last year. Bank clearings for the week in Chicago show a slight increase. As these are regarded as affording an approximate idea of the volume of business that is transacted, it is inferred that general business is slightly improved.

M. Pepperman, Greenville, Miss., was a buyer here last week.

A. A. Burbank, Rochelle, Ill., figured among the buyers here last week.

Mr. Todd, accompanied President Cole, of the Towle Mfg. Co., to Cincinnati, the end of last week.

The Wadsworth Watch Case Co. report an improvement in business, both in and out of town. Jobbers are buying lines for travelers and for filling small orders.

J. H. Leroy, Fairbury, Neb., made a few purchases on his return with his two young sons from a visit to his parents in New York State.

Rose & Carter Co., of Chicago, have incorporated with a stock of \$5,000, to deal in jewelry; incorporators, Frank G. Jones, Claude B. Davis, George R. Hemingway and John R. Carter.

C. E. Brown, Jackson, Mich., who has formerly given his time to repairing, has taken his brother-in-law, of South America, as partner and bought his first stock of a general line of jewelry the past week.

A September wedding of more than local interest will be that of Charles H. Bard, Sedalia, Mo., and Miss Anna Mertz, of that city. Mr. Bard is a progressive young man and highly regarded in business circles here.

J. A. Limbach, just returned from an ex-

tended coast trip for Foster & Bailey, reports his sales fully equal to those of last year. Considering the present condition of the Pacific coast general trade, this is regarded as an excellent showing.

Mr. Wilkins, who has lately covered the far west for the Ostby & Barton Co., reports that about the same quantities and kinds of goods are being sold this year in that territory as were asked for last year. Trade generally is in a waiting condition there as elsewhere.

Alvan W. Ketcham, indicted on a charge of conspiracy in connection with the Leon diamond frauds some months ago, was surrendered on his bond of \$5,000 and taken to the county jail. Ketcham's bond was signed by Edward L. Smith and William T. Hows. Bondsman Smith surrendered the accused man. Ketcham left Chicago some time ago and went east. Bondsman Smith suspected that the accused intended to remain away and had him brought back.

### Kansas City.

The firm name of the Eyssell Jewelry Co. has been changed to Eyssell & Hickman.

Wm. Wooland, Olathe, Kan., was visiting the jobbers last week.

Isidor Eller, Richmond, Mo., held a successful auction last week.

J. C. Shomo, Ottawa, Kan., and H. L. Hodges, Paola, Kan., were in town buying last week.

L. U. Jeanneret, the pawnbroker and jeweler, of this city, has given a realty mortgage for \$500.

W. E. Hoefler and Flint Bowen, traveler for Edwards & Sloane Jewelry Co., are back from Chicago.

C. L. Merry is making a tour of the northern lakes, and will visit New York and Boston before his return in the latter part of August.

C. H. Avery & Co., Auburn, Neb., have just finished a very successful auction sale. Chas. E. Manor, Kansas City, was the auctioneer in charge.

C. H. Curtis, Eureka, Kan., was in town last week on his way home from Chicago and the east. Mr. Curtis reports business picking up

in Kansas, and prospects good for Fall trade.

The latest concession to the crusade for Saturday afternoon closing is the agreement which was entered into July 17th by leading jewelers to close their places of business at 12:30 o'clock Saturday afternoons until Sept. 1st. The agreement went into effect July 18th. The jewelers have been trying to come to this agreement for several years, and although their closing was entirely independent of that of the dry goods stores, it was undoubtedly influenced by the latter's action. The jewelry firms signing the agreement are: The Jaccard Jewelry Co., Cady & Olmstead, F. W. Meyer, J. R. Mercer, Harsch Bros. and C. E. Russell.

### Cleveland.

F. J. Patton has been called to Canton to attend his father, who has not been expected to live for some days.

A couple of weeks ago Elias H. Rathman, jewelry and notions, located at 39 Broadway, made an assignment to attorney Emil Joseph. The assets were about \$10,000 and the liabilities over \$16,000. The bond was filed at \$10,000. A few days after the assignment Mr. Rathman's house was burglarized and several hundred dollars' worth of jewelry was taken. He made an effort to keep the fact out of the newspapers, but with very little success. It looks as if he had failed to turn all the goods over to the assignee.

The past week has been the greatest week in the history of Cleveland. Wednesday, July 22d, marked the close of the first century of the city's existence. There will be about six weeks of special events, banquets, etc., to celebrate the event. Among these is a military encampment which will last during that entire time. Several of the U. S. A. troops are encamped there, while different regiments of the O. N. G. will camp in succession. Troop A, O. N. G., went into camp first. R. E. Burdick, president of the Bowler & Burdick Co., is captain of the troop and returned from a trip to Europe in time to take command. J. T. Vansant and H. Mansfield, both with the Cowell & Hubbard Co., are also members of the troop.

ASK YOUR JOBBER FOR  
S. O. BIGNEY & CO.'S HIGH  
GRADE

# CHAINS

THEY EQUAL SOLID GOLD IN STYLE AND FINISH.



NOTE TRADE-MARK.



**Pacific Coast Notes.**

G. G. Button, Hollister, Cal., has fitted up a new shop.

J. W. Minnick, Cheney, Wash., has been sued for \$131.

N. M. Bailey, Rio Vista, Cal., has invested in the Dozier property in that town.

Walter Jones, Seattle, Wash., has lately purchased real estate valued at \$125.

I. Nason, Redding, Cal., has returned from a business trip through the northwest.

J. L. McCulloch, Princeville, Ore., wedded Mrs. Jane Compton, of that place, recently.

Barrett & Colt have bought the jewelry business of J. Hardwick, Walla Walla, Wash.

W. E. Doty has sold out the jewelry business he has been conducting in San Diego, Cal.

F. M. Jackson, Los Gatos, Cal., has returned from an extended trip into Trinity county, Cal.

J. Glick, Stockton, Cal., with H. J. Keuchler, has started the Insurance Watch Repairing Company, of that city.

S. J. Sturgeon, of the millinery and jewelry firm of M. Sturgeon & Co., Tillamook, Ore., has given a chattel mortgage for \$300.

Read McCraney, Martinez, Cal., and John Sherburne, ex-county treasurer, will shortly open up together in Sonora, Tuolumne county.

The bill of sale of A. Steffanoni, Oakland, Cal., has been turned over to him. Mr. Burdick, the new partner, paid the debts of the house, which amounted to \$14,000, at 50 cents on the dollar, and took in return one-half interest in the business. Burdick is backed by his brother-in-law, Mr. Morris, an Oakland capitalist.

**San Francisco.**

Leon Carrau, of Carrau & Green, is spending his vacation in southern California.

James A. Sorenson, formerly with P. B. Schmidt, has opened a retail store at 135 6th St.

A. Korek, formerly with J. Neilson, has opened up a repair shop at Front and Market Sts.

A. Goodman, the Market St. jeweler, has been in Nevada City, Cal., looking for a business opening.

The jewelers in the Baron block, Post St., are rejoicing at the prospect of the building being modernized.

John Serex, agent of Jos. Fahys & Co., New York, has returned from the east. He has added to his stock a line of silverware.

Thos. Lundy, of the Emporium, has decided to sell out his bicycles and confine his attention entirely to the jewelry business.

M. Wunsch, of this city, has been appointed receiver in the matter of Mr. Josephs, Los Angeles. The proposed settlement at 40 cents yet awaits signatures of eastern creditors.

**Detroit.**

Eugene Deimel, jobber, returned last week from a trip to Port Clinton, O.

Edel & Steinhart, the White Topaz Co., have started a branch store at 117 Woodward Ave.

Col. Dawson, Chicago, is conducting the auction sale of the Frank Cross jewelry stock, Grand Rapids, Mich.

John Smith & Co., gold and silver platers, have applied for a patent on a new bicycle

plate, and will shortly begin its manufacture.

The prize medals for the coming regatta of the Northwestern Amateur Rowing Association are completed and are on exhibition in the show windows of Wright, Kay & Co.

Hugh Connolly, the Detroit Opera House jeweler, furnished silver prizes to be given to the winners in the games shortly to be held by the Typographical Union, at Sugar Island.

The following country dealers purchased goods here last week: George Flint, Carson City; H. Winkleman, Manistique; C. E. Montford, Utica; J. G. Thrasher, Trenton; H. D. Lane, Butler, Ind., and L. W. Winkleman, St. Ignace.

Nels Johnson tower clock manufacturer, Manistee, Mich., last week sold a \$985 tower clock to the city of St. Joseph, Mich., for the new court house. It is called the Century Tower



No. 951. Prize Cup.

**The Meriden  
Silver Plate Co.  
The Meriden  
Cut Glass Co.**

...Formerly...

133-135 Wabash Avenue.

...Now...

149-151-153 State Street.

**PRIZE CUPS and  
LOVING CUPS**

In numerous shapes and  
styles. Prices low.

**Walton, Stanley & Fowler,  
149-151-153 STATE STREET,  
CHICAGO, ILL.**

**SOLD EXCLUSIVELY THROUGH  
THE JEWELRY TRADE.**

**Colonial**

**STERLING SILVER  
TABLE WARE.**

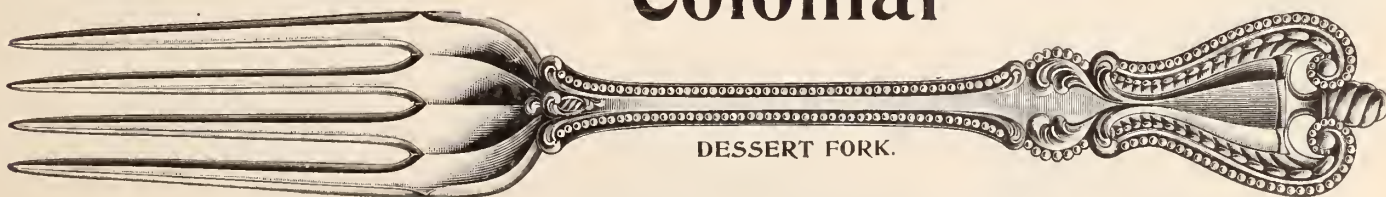

DESSERT FORK.

CHICAGO,  
149-153 STATE ST.

**TOWLE MANUFACTURING COMPANY,  
NEWBURYPORT, MASS.**

Clock, and weighs 2,200 pounds. The bell, which was manufactured by the Troy Foundry Co., Troy, N. Y., weighs 1,000 pounds.

### Indianapolis.

Preparatory to making some changes in their store room, Julius C. Walk & Son are making special prices on all silverware.

Fire broke out in the Naylor Opera House building, Terre Haute, Ind., July 21st, and quickly communicated to the building next door, occupied by jeweler E. W. Leeds. Mr. Leeds estimates his loss at \$5,000; \$3,000 insurance.

F. W. Trewin, Keystone Watch Case Co.; H. E. Vincent, Simpson, Hall, Miller & Co.; Mr. Richardson, A. A. Greene & Co.; Mr. Sherley, C. Dorflinger & Sons, and a representative of John Holland Gold Pen Co., called on Indianapolis trade last week.

### The Silver Question Illustrated in a Jeweler's Window.

W. P. SEDGWICK, jeweler, Bath, N. Y., has placed in his store window a practical illustration of the silver question. On one side are ten silver dollars, good the world over for their face value, by reason of the credit of our government. Underneath these he has a block of silver which is the melted product of ten silver dollars, and which in that form is worth just \$5.24 $\frac{3}{4}$ . On the other side is a \$10 gold piece, and underneath a piece of gold obtained by melting ten gold dollars. Both pieces of gold have the same value whether they bear the government stamp or are a shapeless lump. On the silver melting, however, Mr. Sedgwick will have to lose \$4.75, as he can never get that block of silver which is worth only \$5.34 $\frac{3}{4}$  back into the shape where it was worth \$10.



**100.00 Bicycles**

Are as perfect as the very best material and mechanical genius can make them.

Write for Catalogue and Agents' Terms.  
Send 10 cts. for Elgin King Scarf Pin.

Address Dept. A,  
**ELGIN CYCLE CO.,**  
ELGIN, ILL.

**PARSONS & SCHOOL**  
—FOR—  
**WATCHMAKERS,**  
PEORIA, ILL.  
Send for Circular and Terms,  
**PARSONS & CO**

### Cincinnati.

Oskamp, Nolting & Co. are getting out a catalogue for the Fall trade.

The travelers of Albert Bros. will carry out next month a large number of photos of the bronzes they carry in stock.

Returned jewelers from vacations are J. Gilfilan, of Oskamp, Nolting & Co.; L. Gutman, O. E. Bell, John Holland and A. G. Schwab.

Ike Levendorf, who formerly traveled for Henry Hahn, has opened a novelty store in the Arcade. He is also making a specialty of campaign buttons.

Joseph Becker, agent of the Brooklyn and Fahys Watch Case companies, has been on a tour of the large cities of Ohio, and reports business improving.

Visitors in town last week were: Chas. Schlenker, Union City, Tenn.; Peter Stark, Manchester, O.; M. Stanley, of Stanley & LeFevre, Hillsboro, O.

O. E. Bell has returned from Wilmington, O., where he has been in the interest of his hotel, "The Midland," of which he has been the proprietor for several years.

Lew Boli, a former citizen of Hamilton, O., but later a resident of Kentucky, has returned to his native heath and will open a new store in Hamilton and get ready for the Fall trade.

M. Gondar, Yuma, Ariz., is in Cincinnati this week buying stock for the Fall trade. He expects a revival of business shortly, owing to the good crops everywhere in the west and south.

Thursday, Aug. 6th, the optical fraternity of Cincinnati will hold an important meeting, to which all the trade are invited. It was decided that an organization of this line could be made one of great benefit to the trade.

A man was arrested last week by the name of Frank Schendler who is said to be an apt pennyweighter. He switched a bogus gold ring for a good one at Phillip's pawn shop and tried the same game at Greenwald's jewelry store at 4th and Plum Sts., but did not succeed.

Travelers going out this week are: Isa Schroder, Dave Jacobs, Eli Gutman, of L. Gutman, Wm. Marum, Lou Twachman, J. D. Mulharen, of Oskamp, Nolting & Co., and Henry Hahn. Travelers already out are: Jonas Wise, H. C. Pfaffle, of L. Gutman; L. Labusher, of O. E. Bell Co.; Ed. Schilman, Wm. Gradel, of Oskamp, Nolting & Co.; Eugene Frohmyer and Gus Frank, of D. Schroder & Co.; C. J. F. Bene and August Newstedt, of Bene, Lindenber & Co.; Messrs. Bloom & Phillips; Julius Hahn for Henry Hahn.

### St. Louis.

Morris Bauman, of L. Bauman Jewelry Co., is contemplating a trip to Colorado in the near future.

C. M. Perkins, president of the St. Louis Silver Co., has returned from a visit to Chicago.

At the Populist convention, A. A. Noe, an Ohio delegate, presented Senator Allen, the chairman, with a gavel containing 16 pieces of

silver and one of gold. It was spoken of as a work of art.

Edwin Massa, of the Bauman-Massa Jewelry Co., left on a southern trip July 20th. He will visit Tennessee, Mississippi and Alabama before he returns. Already a batch of orders have been received, showing how he has put in his time.

Mr. Nason, of the Barbour Silver Co. and the Holmes & Edwards Silver Co., was here last week for a short time. He stayed long enough to get his samples in order and again went on the road.

Louis Block was arrested in this city on the 20th inst. on complaint of the American Surety Co., who allege that while he was employed as cashier for Nelson Morris Beef & Pork Packing Co., of Chicago, he absconded with \$500.00. This man, it is stated, decamped several years since with a like sum while employed by a wholesale jewelry house of this city.

One of the saddest consequences of the cyclone is the case of Henry Chambers, 1918 Park Ave., mention of which in part was made in THE CIRCULAR previously. Mr. Chambers was building up a nice trade when the torrado practically wiped out entirely his \$1,500 stock, and injured him so severely that he is barely able to get out now on crutches.

The Populist and Free Silver Conventions were both held in this city during the past week. But the delegates left little cash with our jewelers. Quite a number of out-of-town jewelers were in the city, among them being: C. W. Beardsley, Litchfield, Ill.; John Koetting, Ste. Genevieve, Mo.; John Smelzer, Centralia, Ill.; E. A. Huder, Cairo, Ill.; J. L. Wolff, Red Bud, Ill.; S. Beck, Dallas, Tex.; Geo. C. Sipell, Nokomis, Ill.; Mr. Enfield, of Lackner & Enfield, Paragould, Ark.

### Canada and the Provinces.

E. Jacot, Quebec, returned last week from his trip to Paris.

Sydney Lee, of T. H. Lee & Son, Toronto, was in Montreal a few days last week.

William Eaves, Montreal, spent last week at Caledonia Springs for the good of his health.

George Chillas, agent in Canada for the Fairpoint Mfg. Co., is doing the west, between Montreal and Winnipeg.

D. R. Dingwall, of D. R. Dingwall & Son, Winnipeg, went east to Toronto and Montreal last week on a holiday trip.

A. A. Abbott, manager of the Canadian branch of Smith, Patterson & Co., has gone to the seaside for a short vacation.

James Robertson, of William Bramly & Co., Montreal, has returned after a successful trip through the lower provinces.

At the meeting of the creditors of Cyrille Duquet, Quebec, held July 21st, F. X. Gosselin was appointed assignee of the estate.

Walter J. Barr, of the Goldsmiths' Stock Co., of Toronto, passed through Montreal last week on his way home from a trip through the jewelry manufacturing centers of the New England States.

**The Latest Patents.**

ISSUE OF JULY 21, 1896.

**561,356. BADGE PIN OR BUTTON.** GEORGE A. ADAMS, Irvington, N. J., assignor to the Whitehead & Hoag Company, of New Jersey.—Filed March 28, 1896. Serial No. 585,204. (No model.)



In a badge pin or button, in combination, with a shell having a marginal rim or bead, a covering bearing an inscription, design, emblem, or the like, over said shell and having its edges turned down over said marginal rim, a ring or collet in said shell placed over the edge of said covering to hold or secure the latter in position, and a bar or pin having one of its ends bent to form a holding portion adapted to be secured in said ring or collet,

**561,364. HAT PIN.** MALLEY H. COLTHARP, Tal-



lulah, La.—Filed Jan. 31, 1896. Serial No. 577,498. (No model.)

**561,399. BUCKLE.** JAMES V. WASHBURN, Waterbury, Conn.—Filed Oct. 23, 1895. Serial No. 566,623. (No model.)

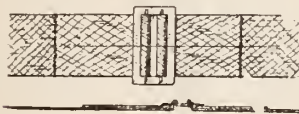

A clasp or buckle comprising a frame having an aperture for the reception of webbing, and a gripping bar located in the said aperture and connected at its ends with the frame so as to tilt or rock on its longitudinal axis under the draft on the webbing, for gripping and releasing same.

**561,466. STEREOSCOPE.** CHARLIE BRIGGS and FREDERICK W. MASTERS, Manchester, England.—Filed April 30, 1896. Serial No. 589,746 (No model.) Patented in England July 2, 1895, No. 12,708.

**561,493. WATCH CHAIN HOOK.** JOHN WILDE, Providence, R. I., assignor to Joseph L. Sweet, Attleboro, Mass.—Filed March 18, 1895. Serial No. 583,648. (No model.)

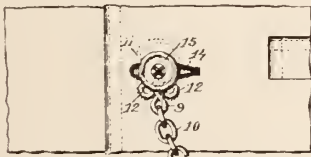

In a device for securing chains or other articles to garments, the combination with the hook 6 and the pendant portion 7, of the loop 11, extending upward from the lower inner part 8 of the hook at each side, whereby when entered into a buttonhole the button, when button 1, holds the hook against lateral displacement and removal.

**561,501. NOSE-PIECE FOR EYEGLASSES.** HENRY BORSCH, Chicago, Ill.—Filed Dec. 7, 1895. Serial No. 571,432. (No model.)

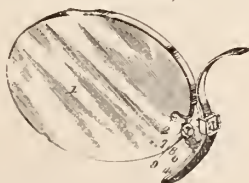

The combination in a pair of glasses, of a stiff carrying-arm rigidly supporting a main bearing surface

and having a spring secured thereto, and a second or supplemental bearing surface secured to said spring and overlapping or projecting beyond said main bearing surface toward the nose.

**561,518. EYEGLASSES.** FRANZ HEILBORN, Breslau, Germany.—Filed Aug. 15, 1895. Serial No. 559,404. (No model.)

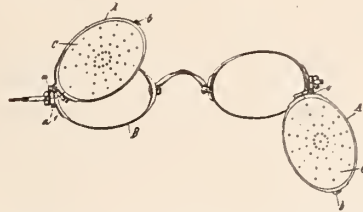

Eyeglasses comprising the glass proper, and a perforated plate pivoted or hinged thereto at the margin so as to be capable of being swung clear of the glass.

**561,543. ENGRAVER'S BLOCK.** HENRY STRAW, Garner, Iowa.—Filed Aug. 22, 1895. Serial No. 567,129. (No model.)

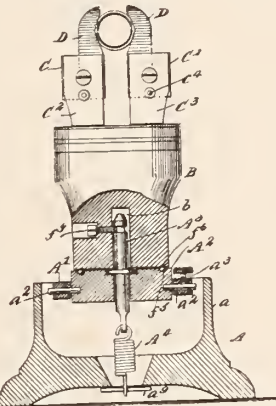

An engraver's block, comprising a base, a ring adapted to swing relatively to the base, a bed piece adapted to swing relatively to the ring, and a yielding anchor.

DESIGN 25,820. POCKET-BOOK, &c. PHILEMON



O. DICKINSON, Newark, N. J.—Filed June 1, 1896. Serial No. 593,933. Term of patent 3 years.

DESIGN 25,821. POCKET-BOOK, &c. PHILEMON



O. DICKINSON, Newark, N. J.—Filed June 1, 1896. Serial No. 593,934. Term of patent 3½ years.

DESIGN 25,824. BADGE HENRY W. HARVEY, Providence, R. I.—Filed Mar. 4, 1896. Serial No.



581,858. Term of patent 3½ years.

DESIGN 25,825. BREASTPIN. MICHAEL STOPPER, Cincinnati, Ohio. Filed May 18, 1896.—Serial No.

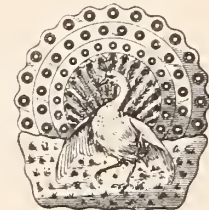

592,061. Term of patent 3½ years. TRADEMARK, 28,657. WATCHES, NEW YORK STANDARD WATCH COMPANY, Jersey City, N. J.—Filed June 24, 1896.

**NEW ERA**

Essential feature.—The words "NEW ERA." Used since June 29, 1895.

TRADEMARK, 28,658. WATCHES, MOVEMENTS AND PARTS. AMERICAN WALTHAM WATCH COMPANY. Boston and Waltham, Mass.—Filed June 22, 1896.

**MAXIMUS**

Essential feature.—The word "MAXIMUS." Used since May 28, 1893.

In these days of bicycling, tennis and other sports, a demand has arisen, greater than ever before, for cups appropriate for prizes for such contests. To fill this demand Walton, Stanley & Fowler, 149, 151, 153 State St., Chicago, Ill., are showing a fine line of prize cups, chaste in design, covering every conceivable line of sport, with many pretty models that may be engraved to fit any special sporting event. Every jeweler should have one or more of this class of cups for local contests, and the line of Walton, Stanley & Fowler, manufactured by the Meriden Silver Plate Co., specially commends itself to the consideration of the trade.

The Niagara Silver Co., Niagara Falls, N. Y., have issued illustrated sheets showing cuts of their Tipped, Shell and Vernon patterns in silver plated flat ware, and their sets and single pieces in their Tacoma, Cinderella, Gladys and other patterns.

Jeweler Nichols, Southington, Conn., is having his store greatly improved by having large and handsome plate glass windows put in to embellish the store front.

**W  
A  
T  
C  
H**

**GOLD FILLED.**



**C  
A  
S  
E  
S**

**A Loving Wife's Advice.**



She urges her worrying husband, in order to increase his business, to read from week to week

**THE 20 DEPARTMENTS**

IN THE JEWELERS' CIRCULAR PER \$2 00 YEAR

### Workshop Notes.

**Gold Tinge on Silver.** A bright gold tinge may be given to silver by steeping it for a suitable length of time in a wash solution of sulphuric acid and water, strongly impregnated with iron rust.

**Mounting the Dial.**—The pin holes in the dial feet should be drilled with a very small drill in such a direction that the pin will not come in the way of anything and can be easily gotten at; they should not be drilled below the surface of the plate, but broached until the pin touches it. If the hole should be a little below the surface, it is better to lengthen the coffer foot by squeezing it with a pair of blunt nippers, until it is above the plate, than to leave it in such a position that no pin can stop it.

**Gold from Old Color Baths.**—The collected exhausted coloring baths are poured into a sufficiently large pot, an optional quantity of nitro-muriatic acid is added, and the pot is placed over the fire, during which time the fluid is stirred with a wooden stick. It is taken from the fire after a while, diluted largely with rain-water, and filtered through coarse paper. The gold is recovered from the filtered solution with a solution of sulphate of iron (green vitriol), which is stored in air-tight bottles, then freshened with hot water, and finally smelted with borax and a little saltpetre.

**Specific Gravity.**—The jeweler, after having smelted his bench scrapings, sweepings, etc., and reduced them into a button, desires to roughly estimate the percentage of the precious metals contained in it. This can be done approximately as follows: A certain quantity of it is taken and drawn out into a wire, which is to be exactly of the same length

as one from fine silver; of course, both must have been drawn through the same hole; silver being nearly one-half lighter than gold, it is natural that the one of fine silver must be lighter, and the increased weight of the wire under test corresponds to the gold contained in it.

**The Barrel Arbor.**—If the pivots of the barrel arbor are of the proper shape (which they generally now are in the best movements or certainly ought to be) the pivots and holes will only require smoothing, and the barrel falling on the arbor. Instead of adopting the usual course of turning away the bosses in the barrel and cover to reduce the rubbing surfaces, a deep hollow should be turned and a shoulder formed on each side of the arbor of a sufficient width, and the bosses should be left on the brass as large as possible. It has not been the practice to snail the barrel arbors of fusee watches, as there was no trouble with the adjustment of the mainspring. English springs are tapered and generally filed thin at the eye, but the arbors should be snailed and the hook should not project beyond the thickness of the spring.

**Parting with Concentrated Sulphuric Acid.**—It is not necessary to scrupulously observe the exact proportions of the gold to the silver. After having prepared the auriferous silver, place it in a quantity of concentrated sulphuric acid contained in a porcelain vessel, and let it come to a violent boil. When the acid has either become saturated and will dissolve no more, or when solution is complete, remove the dissolving vessel from the fire, let it cool, and for the purpose of clarifying, pour dilute sulphuric acid into the solution. The dissolved silver is next carefully decanted from the gold sediment upon the bottom, another portion of concentrated acid

is poured in, and the gold is well boiled again as it will still contain traces of silver; this operation may be repeated as often as is deemed necessary. The solution poured into the glass jars is well diluted with water, and the silver is then precipitated by placing a sheet of copper in the solution. The precipitation is then freshened with hot water, which may also be done by washing upon the filter; the granulated (sulphate of silver) silver is pressed out in linen, dried and smelted. The freshened gold, after being dry, is first smelted with bisulphate of soda in order to convert the last trace of silver into sulphate, and then smelted with borax and a little saltpetre.

**Shape of Ruby Pins.**—A cylindrical ruby pin cannot enter the notch so deeply as it should, and the driving side of the notch will work very minutely toward the front part of the pin, and at the wheel's drop the off-side of the notch will be some distance from the side of the pin; this vacuity between the notch and the pin is a loss of arc to the roller on each side of the discharge, and also causes some small portion of the lever's arc to be non-effectual immediately after unlocking, for directly after unlocking the lever will drop across the vacant space, which is, perhaps, 1° of the lever's arc on each side. This loss of arc by notch and pin often misleads persons in the arc of the pallets from drop to drop. When the arc of the balance, from drop to drop, is about 30°, and the roller, from staff to pin, is about one-third length of the lever, the arc of the pallets is supposed to be 10°—they are more than 10°, generally about 12°—the depths make a greater arc in unlocking than one is aware of.

**Pallets and their Functions.**—Each of the two pallets are shaped for the double purpose of impulse and locking; by turning the scape wheel forward, a tooth of the wheel passes over one of the impulse plane and thereby turns the pallets and lever together through a small arc of perhaps 9°, and as the roller and balance are linked to the lever by the pin and notch, the balance also is simultaneously turned through an arc, the balance's arc always being much greater than the lever's arc, according to the ratio existing between the radii and the small roller and long lever. At the extreme end of the pallet plane the impulse action ceases, and another tooth of the escape wheel drops on to one of the opposite locking, stopping all the machinery of the watch, except the balance and roller, for at the instant of the escape wheel's drop, the roller's jewel pin passes out of, or away from, the open notch of the lever, and the balance and roller revolve by themselves perfectly detached from the rest of the mechanism of the watch.



### “PLAYING DOCTOR.”

Here is another of Rogers' beautiful groups, filled with humor and life. It represents three interesting children at play, cleverly grouped, so that a most artistic effect is given without destroying the naturalness of the scene.

Price, \$9.00. Send for Catalogue. Agents wanted.

Rogers Statuette Co.,  
441 Pearl St., N. Y.

**PLAIN SOLID  
GOLD RINGS.**

∴ Full Quality Guaranteed. ∴

*L. B. & L. Smith*

∴ Manufacturers, ∴

**53 MAIDEN LANE,  
NEW YORK.**

## The Hayden Century Clock.

**M**R. J. F. HAYDEN, class of '96, Trinity College, Durham, N. C., has designed and constructed a novel clock which may now be seen running in the Physical Laboratory, says a writer in the *Electrical Engine*. The clock is run entirely by electro magnets, which are actuated by the current from an earth battery. The pendulum is constructed after the usual pattern, with wooden shaft and

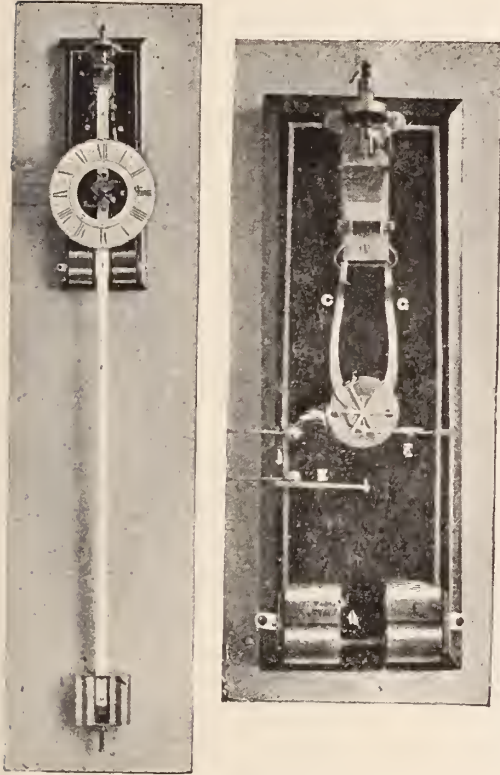

THE HAYDEN CENTURY CLOCK.

heavy cylindrical weights for the bob, and is suspended from the bracket attached to the back-boards, as seen in Figs. 1 and 2. It is the pendulum that runs the clock.

By means of the automatic switch C G, the current from the battery is sent around first one and then the other of the electromagnets D and H. The screw A at the upper end of the pendulum is electrically connected to the upper binding post J, and also to two contact points, one on each side of the shaft at L. The arms C and G, of the automatic switch are insulated from each other. The upper arm G is in metallic connection, through the central screw with a wire in the rear of the back boards, leading to the coils about the pair of magnets H. The lower arm C rests on the brass plate F, the latter being connected with the coils about the magnets D. As the pendulum swings, it is readily seen that the current will alternately pass around the two pairs of electromagnets D and H, and the two soft iron armatures at I will be alternately attracted.

The working of the clock can best be understood by following the current through a complete cycle. Starting from the upper of the binding posts, J, the current passes to A,

then through the piece of sheet steel, B, attached to the upper end of the pendulum shaft, to the contact points, L. When the pendulum starts from the magnets H, towards the magnets D, the contact is made from L through C, and the current will pass around magnets D, and from there to the lower binding post, completing the circuit through the battery. It will be seen that this aids the force of gravity in carrying the pendulum towards D. When the pendulum starts back from D, the contact is made with G, and the current passes around the magnets H, giving the pendulum a pull in that direction. If these pulls at each stroke of the pendulum are sufficient to overcome the loss by friction of the moving parts, it will continue to vibrate.

To regulate the amount of current passing to the electromagnets, two brass tips are affixed to the shaft at K, their distance apart being readily adjusted by screws. Shortly after the contact is made with C, as the pendulum swings toward D, the connection is broken by the arm, C, coming in contact with the strip, K, on that side, and if the current is very strong the strip will push the switch far enough to throw G into contact, and the current will pass around the magnets H. The latter acting will tend to retard the motion of the pendulum toward D. By adjusting the distance between these strips, almost any current may be used to run the clock.

As a novelty in the construction, the works and dial are placed upon the pendulum and swing with it. The seconds hand is attached to a ratchet wheel having 60 teeth, and is actuated at each stroke of the pendulum by the pawls, E E, which are attached to the back board. The motion is communicated to the minute and hour hands by the usual intermediate wheels. The movement is jeweled and the pawls have steel tips. The tips of the pawls work in semicircular grooves in such a manner as to make it impossible for them to catch more than one tooth at each stroke of the pendulum. The length of pendulum is adjustable both at the upper and at the lower end by means of suitable screws.

The lower end of the pendulum is provided with two needle points fixed in the nut, *n*. These pass simultaneously through two drops of mercury, each of which is in metallic connection with one of the binding posts at the right hand lower side of the case. Thus we have a clock that may be used in many laboratory experiments where a seconds pendulum is required. A local circuit will be closed through an electric bell or telegraph sounder at each stroke of the pendulum. All the electrical contact points in the clock are of platinum, and the working parts of the switch are adjustable for wear.

The earth battery is built in the ground near the building and consists of several old boiler grate bars as one electrode and several bushels of coke as the other. The battery will last for an indefinite period and should run the clock for 50 or 100 years.

D. F. Rosen has engaged in the jewelry business in Altoona, Pa.

## The Synthesis of Diamonds.

**T**HE reproduction of the diamond by Mr. Moissan has put the caping-stone to the work of mineralogical synthesis.

For some years past it has been thought that the solution of this problem was merely a matter of time and patience; but it is no little satisfaction to be able to say at last that the thing has been done, for it is indeed a striking illustration of the power over stubborn matter, which is won by the patient student of science. In the light of what has now been accomplished, it may not be without interest to refer to an article that appeared in an English scientific journal on the subject of the production of diamonds, previously to the work of Mr. Moissan. At the conclusion of an article on "The Artificial Production of Rubies," the matter was referred to as follows:

"The great problem in the artificial production is the preparation of the diamond. . . . In the case of other minerals the successful production has generally been achieved only after a minute study of the mode of natural occurrence, and this has afforded guidance as to the best means of imitating the natural process of formation. It is only of recent years that the diamond has been found in its original matrix, so that materials have been wanting upon which to base experimental methods. The chemical nature of the body, a combustible substance, is so different from that of the ruby and most other gems, which are oxides or oxidized materials, that the methods to be employed for its production will probably involve the application of different principles. There is no reason, however, to regard the problem as insoluble. When sufficient guiding data have been obtained, skill will not be wanting to imitate, in the laboratory, the conditions under which nature has worked in the formation of this most beautiful product of the mineral world."

What some of these determining conditions might be was indicated in a subsequent paper on "The Diamond Mines of South Africa," which appeared in the same publication near the end of 1891. "To the mineralogist the chief interest of the South Africa mines lies in the fact that the 'blue rock' or kimberlite, appears to be the original matrix of the diamond. . . . It is worthy of note that a black shale forms one of the surrounding rocks, and pieces of this shale have been found baked and otherwise altered in the blue rock. The suggestion has been thrown out that the diamonds were formed by the alteration of the carbonaceous matter of the shale under the influence of a moderately high temperature and great pressure. Such indications are useful as affording suggestions to the experimentalists, to whom, in spite of previous failures, we must look to tell us definitely how the diamond is formed."

If the diamond be highly heated in the presence of oxygen, it takes fire, as is well known, and burns with the formation of carbonic acid. If it be heated not in contact with oxygen, it swells up and blackens, reverting to

the ordinary charred form of carbon. But the action of heat upon bodies is in many cases very different when they are subjected to high pressure, a principle established by Sir James Hall more than one hundred years ago, in his celebrated research on the conversion of chalk into marble.

As will be seen, Mr. Moissan invoked the aid of pressure to modify the action of heat in his experiments, and produced diamonds from charcoal, a substance of the same nature as the "shale" which occurs in the Kimberley rock. The formation of crystal is, as a rule, best brought about either by sublimation or cooling a solution. Carbon, however, cannot be distilled or sublimed, and is insoluble in all ordinary solvents, such as water, or aqueous solutions of acids and alkalis, or in liquids such as alcohol, ether, or benzine. On the other hand, molten metals can take up or dissolve carbon to a not inconsiderable extent, as happens, for instance in the well known process of iron smelting. The molten iron in the blast furnace dissolves some of the carbonaceous fuel, a part of which, when the iron is allowed to cool and solidify crystallizes out in plates of graphite. This is an example of the production of a crystalline form of carbon from a non-crystalline variety, and it is at the same time an instance of the artificial formation of a mineral.

Mr. Moissan, in his experiments employed iron as a solvent for carbon, which was in the form of charcoal, but he modified the action of heat and the solvent by subjecting the carbon saturated iron to a considerable pressure. It may be noted here that Mr. Moissan finds the principal constituent in the ash of the native diamond to be oxide of iron. It is known, also, that native diamonds often contain liquified gases in cavities of the crystal, and that they are sometimes liable to spontaneous disruption, owing to a state of strain which is probably due to their having been formed under high pressure.

In an earlier series of experiments, iron melted by means of an electric furnace, and raised to a white heat, was allowed to saturate itself with carbon in the form of thoroughly compressed sugar charcoal. The crucible in which the operation was conducted was then plunged into cold water, which cools the outer portion of the metal so as to form an outer layer of solid iron. While this outer coating is still red hot, the crucible is withdrawn from the water, and the cooling proceeds more slowly. To realize what goes on within the jacket of solid iron, we must remember that the still liquid interior is molten iron, containing a large excess of dissolved carbon, and that iron expands in the process of solidifying. Hence, during the process of solidification within the jacket or crust of chilled metal, great pressure is exerted. The process of solidification, therefore, goes on slowly and under great pressure, and an examination of the resulting product showed that, under these changed conditions, a part only of the surplus carbon had crystallized out as a graphite, and that in the residue after dissolving away all the iron by

means of boiling hydrochloric acid and other solvents, there was a certain quantity of a denser form of carbon, having a specific gravity of 3 to 3.5, and hard enough to scratch a ruby; and that among these heavier portions of the residue were transparent particles, having a greasy or waxy luster, and marked with parallel striæ and triangular depressions. These transparent particles burnt when heated to 1050° C. [1922° F.] in oxygen gas, and, as it appeared, with the formation of carbonic acid; but the particles were too small to allow of a quantitative experiment. Similar results were obtained by the slightly modified method of rapidly cooling an ingot of molten iron saturated with carbon from a temperature of 2,000° C.

In a few cases small fragments were obtained "*qu'ils ressemblent aux petites fragments de diamants transparents que nous avons rencontrés dans la terre bleu du Cap,*" (*Comptes rendus*, February 6, 1894.) The result may be summed up by saying that, up to the date of the experiments described in the above quoted paper, Moissan appears to have succeeded in reproducing that transparent variety of carbon of which native diamonds are composed. The specimens could hardly be called diamonds, although they showed certain characters of the native diamonds—to wit, a waxy luster and parallel striæ and triangular depressions on the surface.

Since the experiments above described, a happy modification of the method employed has given results of a far superior kind, perfect diamonds being formed having the distinctive physical peculiarities of the native stone, and of sufficient size for Mr. Moissan to prove by quantitative chemical experiments upon some of the specimens that they burnt with the formation of pure carbonic acid. In the course of experiments made in former years by other experimenters, using other methods, transparent crystalline bodies were obtained which were thought to be diamonds, until the failure to satisfy the carbonic acid test showed that the crystalline particles were not composed of carbon.

Moissan's modified method is as follows: Iron is saturated with carbon at the white heat of an electric furnace and under pressure. The crucible containing the molten iron is then quickly lowered to the bottom of a bath of melted lead. This insures quicker cooling than when iron is plunged in water, owing to the fact first, that the white-hot iron does not really come into contact with the water, and secondly, that the lead is a good conductor and carries away the heat rapidly. It seems that the two liquid metals behave toward one another much as oil and water, and the molten iron collects in spherical globules which rise to the surface of the molten lead, the difference in the specific gravity of molten iron and of molten lead, being, of course, very considerable. The surface of the drops of liquid iron which floats upon the surface of the lead quickly solidifies, the smaller drops with a diameter of one to two centimeters first, and the larger drops after a lapse of a longer time, and the solid little balls of iron are left to float on

the molten lead, where they cool down. The interior of the balls is of course liquid long after the formation of the solid crust. The tendency of the central parts to solidify is resisted by the solid crust, owing to the fact before mentioned that iron expands in the act of solidification. Meanwhile a part of the carbon crystallizes out from its solution in the liquid iron. After a time, as the cooling goes on, the lead also solidifies, and the little iron balls are left imbedded in the ingot of lead. Then begins the process of getting at the small quantity of the carbonaceous material which it is desired to examine. The lead which adheres to the iron is dissolved away with nitric acid, the iron is dissolved by hydrochloric acid, and further treatment with suitable solvents leaves the sought for residue, a small quantity of material left after the tedious process of removing by slow chemical means the relatively large mass of metal.

Transparent diamonds are found in the residue, having well defined crystalline faces, striated and marked in the well known way, and the edges generally curved; they have the high refracting power, the specific gravity, and the hardness of the native stones. The peculiar form known as the *hemihedral* predominates among the crystals as in those of native diamonds, and their formation under pressure is found to give rise to the phenomena of anomalous polarization of the light, which passes through them, as well as to occasionally to spontaneous disruption; characters which, as has been mentioned, are sometimes noticed in the native stone. The diamonds are, of course, small; one with a diameter of half a millimeter appears to be reckoned a fine specimen. Further practice in working the process will probably enable larger specimens to be produced, as has been the case with the production of rubies, which are now produced of a size sufficient to be used for jewelers' watches.

However this may be, the production of diamonds is now an accomplished fact, achieved by the patient skill of the same worker, who, eight years ago, successfully overcame the great experimental difficulties which rendered fruitless the many former attempts to isolate the chemical element, fluorine.

### Wooden Pendulum.

IF clock purchasers only knew, they would invariably prefer clocks with wooden pendulum rods. But for this purpose use well-seasoned fir wood of one year's growth, saw it apart lengthwise, and glue the two pieces together again in such a manner that the veins run in opposite directions. When varnishing it, it is advisable to dip it slowly endwise into the varnish, so as to gradually expand the air; if this job is done hastily, the air will be left in the wood to be acted on by every change of the temperature. Such a pendulum renders services that can favorably compare with a compensated pendulum, as wood is almost insensible to heat or cold.

DEPARTMENT OF  
**ADVICE AND CRITICISM**  
 ON  
**RETAIL JEWELERS' ADVERTISING.**

[This department is free to every retail jeweler and optician. Forward for criticism your newspaper ads., booklets, catalogues, novelties, circulars, etc. Ask advice and offer suggestions. Replies in these columns are unbiased. Make letters as full and particular as desirable. Every letter and ad. sent will receive full attention, though the publication of the matter may sometimes be delayed a week or two. Address all letters and other matters to The Jewelers' Circular Pub. Co., 189 Broadway, New York.]

**PART XXII.**

**NEWTON & LINCOLN,**  
 UP-TO-DATE JEWELERS.

WEST WINSTED, CONN., July 14, 1896.  
 Editor of THE JEWELERS' CIRCULAR:  
 Inclosed please find a few samples of our ads., on which we would like to have you pass judgment in your publication.  
 Respectfully,

NEWTON & LINCOLN.

Correspondents sent three ads. which are here reproduced in as near fac-simile as possible, though in reduced size. The "Esting" ad. occupied in the original 7½ inches, single column; the "It's a Wrong" ad. 5½ inches, single column, and the third ad. 7 inches, single column. All three ads. are

puzzling ads. should be sparingly used. The logic of the ad. will appeal to many readers, and while the ad. may produce little immediate returns, it is good policy on the part of the jeweler to occasionally insert such an ad. so as to foster his reputation as a reliable, truthful and just merchant. We again take occasion to claim that all advertising is not intended to bear immediate fruit in dollars and cents. The establishing of a business on a firm basis can be done by the advertising of just business

The "It's a Wrong" ad. belongs to the instructive variety but the advertisers lost a good opportunity

**IT'S A WRONG**

IMPRESSION to get that you must buy plated ware to use and save your solid silver. If you do that way when you have company and need all you have, your plated will look awfully rusty beside the carefully kept solid. Now if you use the solid, and save your plated, in case of an emergency, you have nicer looking silver for the solid will stand more wear than the plated. In buying plated ware, you should buy some of ours, which looks like solid.

**NEWTON & LINCOLN,**  
 Up-to-Date Jewelers,  
 321 Main St.,  
 WEST WINSTED, CONN.  
 Your money back if you want it.

**'EST ing'**

Don't it weary you to read ads full of "ests?" "Biggest, finest, neatest, latest, largest, &c., &c., and always at lowest price." You read such an ad. and go to the store. You are not particularly impressed with what you see and you are led to think that that firm exaggerates a little in their ads. Ever read our ads? Did you notice that "ests" are very scarce? Now you read our ads and come to the store, you find us the same or better than our ad. stated. The next time you read our ad. you believe it perfectly you come again, you keep coming. Why? We have gained your confidence. That's how we are building up our business.

**Newton & Lincoln**

UP-TO-DATE JEWELERS,  
 321 Main Street.

Your money back if you want it.

principles and by the undeviating exercise of these principles. Such a result is worth several hundred-fold the few sales produced by a catch-penny ad. Therefore let the jeweler occasionally advertise his business, among the necessarily constant flow of ads. that he inserts advertising his goods and specialties.

to combine with it descriptions of goods with prices, which would have been a proper corollary to the philosophy of the ad. as it now stands. The story contained in the third ad. is very readable and interesting, while it brings out two desirable points, the cheapness and reduction of the price of the alarm clock and its good timekeeping qualities. The ad. is very clever, and should gain the point aimed at. The story, true or hypothetical, is well written, and shows a proper modesty and courtesy on the part of the jewelers.

Two good points in the ads. are: first, the sentence, "Your money back if you want it," which shows that the firm are straightforward in their dealings and try to give the money's worth; and second, the sub-heading of the firm name, "Up-to-Date Jewelers." We note that the firm use this phrase in their letter head and other stationery. By the quality which Max Nordau in his "Degeneration" calls *echolalia*, which is almost universal among the people, the constant recurrence of the phrase will

cause it to echo hundred-fold in the mind of the reader, till the impression of the up-to-dateness of Newton & Lincoln will be a long lived association of ideas in the mind of the public.

\* \* \*

Avery's watch repairing ad. is excellently worded. Mr. Avery's ads. are generally good. We would, however, say that Mr. Avery would have received greater returns from his ad. if he had specified a few simple repairing operations with

**TO THE BUSY MAN**

An accurate Watch is a necessity—not a luxury, as some seem to think. To utilize every moment of precious time, to meet trains, keep appointments to be always on time, one must have a good watch. Drop in and let us talk watches with you. We are practical Watch Repairers and Watch Makers, if you please and you can have the benefit of our experience without charge

At AVERY'S.

**Watch Repairing Is a Skillful Art**

And the skilled Repairer is close akin to the Manufacturer. We combine both. If you have a fine Watch and any part is broken or lost, we can replace it. If you've a valuable old Watch that has been ruined by incompetent workmen, let us fix it—no cure, no pay

At AVERY'S,  
 COLUMBIA, S. C.

costs for same. The average person thinks the watchmaker should be classified with the plumber and the ice man, when it comes to charges. A good way to dispel this belief is to quote the lowest possible prices on certain simple operations.

\* \* \*

**Recent Good Ads.**

[Under this heading will be reproduced good ads. (introductory portions only) culled from various sources]

From Printers' Ink.

**It's a Duty**

You owe your eyes—that of properly caring for them. You can't be too careful with nature's foremost blessing—your eyes. Immediate relief awaits affected eyes here—that permanent relief so seldom experienced.

EXAMINATION FREE.

E. P. Roberts & Sons. Pittsburgh, Pa.

**A WOMAN'S REASON.**

"I buy my Wedding Gifts from E. P. Roberts & Sons, because there is an eternal fitness of things about their establishment and an elegance and refinement about that I do not find elsewhere."

Cor. Fifth Ave. and Market St.

**NEWTON & LINCOLN.**

Up-to-Date  
**JEWELERS,**  
 321 Main St.

Your money back if you want it.

unusually well worded, though only one, the third, we would infer, was fruitful of results. The "Esting" ad. is very clever, perhaps too clever for a miscellaneous public, for the headline will prove puzzling to some heads, and

# OPPENHEIMER BROS. & VEITH.

CUTTERS OF DIAMONDS,  
DEALERS IN WATCHES,

65 NASSAU STREET (PRESCOTT BUILDING), NEW YORK.

These well-known Razors, the quality of which is warranted, possess this great advantage, that they may be used for ten years before they require actual sharpening. Before using them, it is necessary to rub them on good leather strop. Lecoultre's Strops (to be had with the Razors), should be used in preference to others.

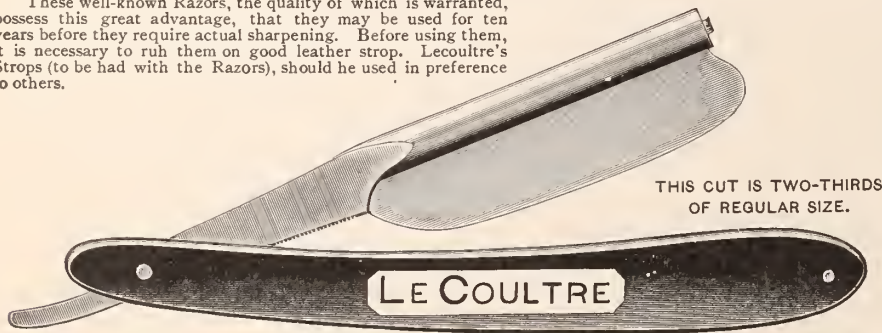

THIS CUT IS TWO-THIRDS OF REGULAR SIZE.

## MATHEY BROS., MATHEZ & CO.,

SEND FOR PRICE LIST

SOLE AGENTS. 21 & 23 Maiden Lane, N. Y.

### SLOAN & COMPANY,

SUCCEEDING

JOHN A. RILEY & SLOAN CO.,

MANUFACTURING JEWELERS,

23 MAIDEN LANE, N. Y.

HAYS BUILDING.

AUGUSTUS K. SLOAN, Pres.  
FRANK T. SLOAN, Vice-Pres.

BENNET OSBORN, JR., Treas.  
ALLAN A. McDONALD, Sec'y.

**NO SOLDER. NO SEAM.**

**SAVE TIME AND MONEY.**

Superior to Anything Ever Shown.  
Apply for Catalogue to

**CHAS. BACHEM,** 249-251 N. J. R. AVE.,  
NEWARK, N. J.  
Manufacturer of  
Marquise Heads, Clusters, Ring Shanks, Gypsy Rings, Etc.



**COMFORT AND SECURITY**  
ARE COMBINED IN  
**MERRITT'S PATENT EYE GLASS HOLDERS.**

Made by Merritt, Craggill & Co. Springfield, Mass.

GOODS ON APPROVAL.  
CORRESPONDENCE SOLICITED.

### ENAMELERS

OF GOLD, SILVER AND PLATED JEWELRY,

Enameled, Plain and in Colors

ALSO OF

**SOCIETY EMBLEMS,  
YACHT AND COLLEGE FLAGS**

All Varieties of Painted Enamel Work.

### S. S. WILD & SON,

179 Eddy Street, PROVIDENCE, R. I.

Correspondence Solicited.  
Telephone Connection.

### DR. KNOWLES' PRIVATE COURSE IN OPTICS.

Lectures with Diploma \$25.00

Those who desire to study with the Doctor will send in their application.

Students received at any time.

CORRESPONDENCE COURSE PERFECTED.

**The Key to the Study of Refraction.**

50c. per copy,

For Sale by

**R. H. KNOWLES, M. D.,**  
189 Broadway, NEW YORK.  
Care of JEWELERS' CIRCULAR.

### Fox & Stendicke,

Manufacturing Opticians,

61 Fulton St., New York.

Javal, Schiötz Ophthalmometers, Phorometers, Skiascopic Apparatus, etc., etc.

Send for Price List.

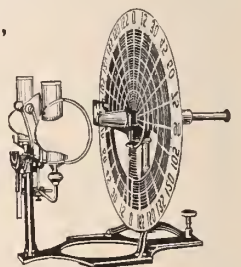

### SECURITY PIN GUARD

PAT'D DEC. 25, 1894  
MANFD BY SECURITY MFG CO. **25¢**

7 ASTOR HOUSE (BROADWAY) N.Y.

85c. doz. Net Cash Discount to Jobbers

### A. J. COMRIE,

AUCTIONEER,

22 John St., N. Y.

SPECIAL SALESMAN OF WATCHES, DIAMONDS.  
BRIC-A-BRAC, FOR ESTABLISHED JEWELERS.

WRITE FOR PARTICULARS.





## The Rambler's Notes.

WHAT THE RAMBLER SAW AND HEARD AMONG THE DEALERS IN ART POTTERY, CUT GLASS, BRONZES ETC.

POPULARITY OF **A**S Summer advances the popularity of the BOHEMIAN GLASS. beautiful Bohemian decorated glass vases continues to increase. A fine collection of these vases recently opened at the warerooms of C. L. Dwenger, 35 Park Place, New York, contains many new and rich ideas in colorings and decorations, each of which is shown in seven different size vases. A novelty is to be seen in yellow opaque vases decorated with gilt vines and heavy ornamental gilt bands at the top. Some new effects are shown in shaded colored glass, principally in green, ruby and violet hues.

NEW ART GOODS **L.** W. LEVY, of Levy, Dreyfus & Co., returns this week on the *New York*, from a three months' visit to the markets of Europe. Mr. Levy has been selecting his firm's Fall stock of bric-à-brac, pottery and art goods generally, which includes many new and novel lines soon to be seen at the firm's salesrooms, 9 and 11 Maiden Lane, New York.

RICH ONYX CLOCK. **O**NE of the richest and most attractive lines of onyx clocks ever displayed by the Chas. Jacques Clock Co. is now to be seen at their warerooms, 22 Cortlandt S., New York. The clocks are opalescent Mexican onyx, showing deep green and blood red shades and possess a polish equal to glass. They come in large mantel sizes with gilt corniced Corinthian pillars and in the old tambour shapes.

THE RAMBLER.

## Recent Crown Derby Productions.

**T**HE Royal Crown Derby Porcelain Co., Limited, have always on show at their London rooms, 42 Holborn-viaduct, E. C., a splendid assortment of their high class china. It is no secret that Crown Derby body admits of a treatment in color that cannot be surpassed elsewhere. One cabinet in the London

show-rooms contains some exceptionally beautiful art vases splendidly modeled and most exquisitely decorated. The penciling of the gold work, in various shades, is executed with the greatest delicacy. There are vases of beautiful outline and of every imaginable hue, the famous Derby blue, of course, predominating. There are some beautiful examples of the work of Monsieur Leroy, an artist of whom the firm may justly be proud. Some Gainsborough and Reynolds sets have paintings after these celebrated masters—fine specimens of the combination of the art of the painter with that of the potter. The gold chasing on some of these pieces is superb, while the smallest details of decoration are most highly finished. As an example of this may be mentioned that in one of a set of tablets forming the border of a plate, there was an open book of music in which even the musical notation was readable. The company are showing a choice collection of their Old World blue. A recent introduction is the Lowestoft Derby style of decoration. There is the characteristic blue border and the Derby flowers. The blue painted border has a soft and pleasing effect. This style of ornamentation is shown to equal advantage on vases, jardinières, plant pots, and a number of table decorations.

Another revival is that of the old Berlin style. This is a floral decoration applied to both useful and fancy articles, and is a treatment that, as far as present day work is concerned, is quite new. The flowers—mostly roses—seem to have been thrown at the plate, and they are represented just as they fell, sometimes with a side view and sometimes with a back view only, the center of which is, necessarily, the stalk. This is quite a change from the front view of the bloom, to which we are most accustomed. Another feature of this decoration is that a number of buds are introduced—a natural feature which is too frequently ignored in favor of the perfect flower.

The Royal Crown Derby Co. do not by any means confine themselves to fancy goods. They are extensive manufacturers of tea, breakfast, dessert, and dinner services. In all these their high class decoration is seen and is applied to several quite new shapes. The "Empire" dinner set is a case in point, a useful set with quite an art decoration.

Another revival is what is called the "Chelsea-Derby" style. This contains the well known Chelsea groups on Derby shapes, and, of course, in Derby ware. This style was to some extent accidental. More than 120 years ago the Chelsea and Bow China Works were sold, and being purchased by a Derby manufacturer, men and moulds and plant were transferred bodily to Derby and incorporated with the works and workers there. The amalgamation of the hitherto distinct schools was complete, and as all the distinct features of those styles have been handed down and are held in direct descent by the workers for the present company, a revival of them is at once interesting and appropriate. Two new greens attract much attention—the new Autumn green and the Empire green. These are primarily intended for America, where just now green is the favorite color. There is, however, a demand for them in England, and so they are introduced on articles designed for home use.

## Carrara's Marble Quarries.

**T**HE British Vice Consul at Spezia, in a report on the Carrara marble industry, says that last year the production of the quarries was 108,951 tons of ordinary and statuary marble, and 52,360 tons of sawn and worked marble.

The different kinds of marble in the market from the Massa Carrara quarries are statuary or Carrara, properly so called; Sicilian, veined, dove and peacock. There are a few colored quarries, but their product is insignificant. Massa produces some colored marble. There is a quality of marble, perhaps the most rare, and for some purposes the most beautiful, known as "pavanazzo," or peacock. It has a creamy ground with blood violet or purple markings or veins. Of the Sicilian (*bianco-chiaro*) blocks of almost any size can be obtained. It is only a question of transport. Blocks weighing as much as forty tons have been seen at Carrara. A quarry of red marble has lately been worked near Garfagnana.

The main valleys in which the quarries lie are the Ravaccione and Fantiscritti. To reach the Ravaccione a long valley of quarries has to be passed, at one end of which, named Crestola, the finest statuary marble is excavated, while at the other end the commonest

"Sicilian" is found. Two explanations are given for naming the ordinary biancochiario marble "Sicilian." One is that during the French occupation of Italy it was sent to Sicily and thence to England. The other that the vessels loading marble afterward went to Sicily to complete their cargoes with fruit, etc.

The number of quarries is estimated at 645, of which 387 are worked. Of these about 229 give Sicilian, 27 statuary, 22 veined, 7 dove, and 2 peacock marble. The quarries give work to 4,500 quarrymen, whose wages range from 8s. to 2s. a day. Another 1,000 men work in the towns at the sawmills, studios, etc., as sawyers, carvers, rubbers and polishers.

The conditions of labor in the marble district have undergone little change. Wages are much the same as they were twenty years ago, but the purchasing power has decreased, owing to the heavy taxation and enhanced cost of living. Remedial measures to remove or mitigate the grievances that gave rise to the riots in 1894 were proposed before they were quelled, but there has not been time to carry them all into effect. One of them, a fund to provide against accidents and their consequences, has been raised by the addition of a small percentage to the tax levied on the output known as "pedaggio." The sum thus raised during 1895 was £1,950, and five houses were built at the quarries to render first aid.

Accidents and injuries are of daily occurrence. The serious ones are between seventy and eighty yearly, and those terminating fatally are about eight per annum. The quarryman's life is not a pleasant one. He leaves his home often in the small hours of the night, so as to be at his work soon after daylight. A huge slice of bread crammed into his pocket is breakfast and dinner; his supper will be a dish of coarse "minestra," and perhaps a glass of sour wine; meat he never tastes, unless a little on Sunday. Nevertheless, says the Vice-Consul, he is a good fellow, rather rough spoken, and indifferent to his religious observances, but thoroughly honest.

Little machinery is used except at the saw-

mills, and this is made in Italy. A good supply of iron for the saw blades comes from Germany, and is rolled at Undine, in Italy. It is of better quality and cheaper than English. A few tools also come from Germany, but besides these saw blades and tools, other articles, such as machine belts, steel and hardware goods, which at one time were obtained exclusively in England, are now either manufactured in Italy or obtained in Germany. However, there is one article which is always imported from France, viz., "lifting jacks," as those made in Germany or England are not adapted to the requirements of the Carrara quarries.—London Times.

### A Scotch Pearl.

WITH much preparation an old man, half gypsy, half soldier, produced from his pocket a twist of very dirty newspaper. Unfolding this, appeared a second twist of grocer's "white brown," and when this was unrolled with due ceremony he displayed a pearl. It was not a bad one, and was about the size of a sweet-pea seed, with fair gloss and radiance. He proceeded to enlarge on it.

"Now, sir, this is a very fine pearl whatever; it is really worth 20 guineas. I have just sold the like of it to the Duchess of M. You admire it, sir? No wonder. Well, I happen to be out of gold to-day, and you shall have it for a trifle. I will take £2 for it. Reckon it by the cost of seven weeks of work for it took so long to find so good a pearl; put down my day's work at so much," &c. I admired, but declined.

Not so long before I had bought a Tay pearl at a Perth jeweler's for exactly 5s. It was quite as lustrous and nearly as large as the one offered by the old soldier. Indeed, it was so fine that I had it set as a ring in a broad band of gold. After seeing the pearls offered at Perth, unfortunately for the gypsy gatherer, I was enabled to criticise his prices. We parted good friends, however, and he went off to Loch Rannoch. As a good many brides and bridegrooms were staying in that district, the probability is that one of the for-

mer now wears the pearl whose fellow adorns the Duchess of M.—*The Gentleman's Magazine*.

### Diamond with a Feather Tip.

SOME years ago a Paris jeweler told a story of one diamond which had passed over his counter no less than eleven times. It was a beautiful stone of merely four karats, of perfect color and luster, but easily identified by means of a small "feather" in the tip of the lowest part. He bought it from an East India dealer and had it set in a ring. It was sold to a countess in 1869, just before the outbreak of the Franco-Prussian war. The countess died in a few weeks and the ring was worn by her husband. He was killed in the siege of Paris, and a few days after his death the ring was brought into the store for sale by a common soldier. He was arrested and the ring sent to the family of the dead count.

Before the siege ended they brought in the ring and sold it to the dealer in order to procure money to buy food. Directly after the siege it passed into the hands of an English tourist, who visited the city to get a look at the ruin wrought by the communists, and a year later back came the stone from the Indian buyer of the firm, who, on being written to and desired to tell how he got it, stated that it had been the property of an English tourist hunter who had been killed by a tiger, and his friends sold the ring to get means to send the body home.

The stone was reset and soon found a purchaser in a prominent member of the demi-monde, who not long after was murdered in her room. Among the articles taken by the murderer was the ring, and the firm began to wonder how soon it would turn up. They had not long to wait. After six months it was found in the show case of a jeweler in London, who had bought it from a firm in Amsterdam. It was bought by the Paris agent and sent back to be started afresh on its travels. It was purchased again by a woman, who six weeks later was drawn out of the Seine with the gem on her finger, and, by a strange coincidence, it was offered to the firm that sold it by the police agents, the court having jurisdiction having ordered it to be sold. And so it went from hand to hand, attended with misfortune at every change, and usually bringing death to the possessor. Laborers in the Golconda mines used to say that when a stone was baptized in blood when first taken from the earth it caused the shedding of blood wherever it went, and the story of one such ill omened gem goes far to confirm belief in such superstition.

In the article published last week in reference to the Universum clock, it is erroneously stated that Arthur Sirois was the inventor of the clock. The inventor is August W. Nitsch, of New York. He conceived the idea of having the dial represent the earth, and show the time at the point it passes the sun. He also made the star-chart. It was his ideas regarding the mechanism of the clock which Mr. Sirois ably carried out.



355 Mulberry Street.

Newark, N. J.

## JACOT & SON,

Importers and Manufacturers of

## Musical Boxes,

39 Union Square.

New York.

## CUT GLASS FOR SILVERSMITHS



STANDARD CUT GLASS CO.,

545 to 549 West 22nd Street,  
NEW YORK.



Copyright, 1896, by The Jewelers' Circular Pub. Co., 189 Broadway, New York.

A Jeweler's Necessity

For eight months THE JEWELERS' CIRCULAR has had under way a work that will comprise the trade-marks of every branch of the Jewelry, Watch, Clock, Silverware, Silver Plated Ware, Optical Goods, Precious Stone, Art Pottery, Bric-à-brac, Cut Glass and cognate lines of the Jewelry Industry.

The work is now nearing completion. We consider it will be the most valuable book that has ever been issued to the Jewelry trade.

It is a work which the retailer and wholesaler will immediately appreciate.

It will be a book of constant reference, and will be consulted more perhaps than any other book issued to the trade.

It will be a book of daily use.

It will be sold at a figure that will guarantee its rapid distribution.

In addition to illustrations of the various trade-marks and the names and the addresses of the firms to whom they belong, and the class of goods to which they appertain, the work will contain other interesting and valuable information bearing upon the subject of trade-marks.

Members of the Trade, Manufacturers, Wholesalers and Retailers should at once place their orders for

TRADE-MARKS OF THE JEWELRY AND KINDRED TRADES.

\$1 per copy. Bound in Cloth. Payable now or upon delivery of Book. Detach order below and forward to the Jewelers' Circular Publishing Co., 189 Broadway, New York.

Those firms who have as yet not sent electrotype, print or drawing of their trade-mark or trade-marks are requested to do so at the earliest possible moment.

ADVANCE ORDER BLANK.

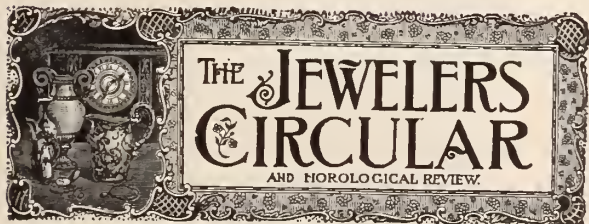

189 Broadway, New York.

.....1896

Please file this order for.....copy of

“ Trade-Marks of the Jewelry and Kindred Trades ”

for which I agree to pay \$1.00 per copy, postage prepaid, upon delivery of book.

Name.....

Street.....City.....State.....

**CYCLING PROGRESS  
EXEMPLIFIED.**

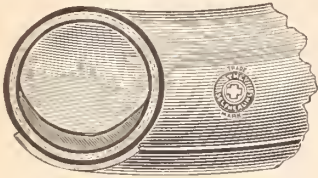

**THE WONDERFUL  
SELF-HEALING TIRES**

are single tube, finest rubber, finest wove Sea Island cotton fibre, re-enforced inside and outside on tread, and no better tire can possibly be made.

They are fully guaranteed against all climatic changes, are the most resilient ever made, and when punctured instantly heal the wound of their own volition.

THEY WEIGH NO MORE THAN OTHERS,  
COST NO MORE,  
AND ARE WORTH TEN TIMES MORE.

—SEND FOR TIRE BOOKLET—

**Wm. H. CAHN, GENERAL MANAGER,**  
48 and 50 Maiden Lane, New York.

**BY EVERY TEST THEY ARE THE BEST.  
THE UNIVERSAL FAVORITES.**



**SUPERB**

**Olympic**  
BICYCLES

For sale by more than 2,000  
Jewelers, and constructed to meet  
the demand for finest quality.  
For Adults and Juveniles.

**SEND FOR EXQUISITE  
CATALOGUE.**

Top Grade "Olympics" have **SELF-  
HEALING TIRES.**

Olympic Cycle Mfg. Co.,  
N. Y. Office: 35 LIBERTY STREET

General Jobbing Ag'ts, **S. F. MYERS & CO.,**  
WHOLESALE JEWELERS, Myer's Building, New York

**RECEIVER'S SALE!  
TRADE OPPORTUNITY.**

Entire Stock of

**CHAS. JACQUES CLOCK CO.,**

22 Cortlandt St., New York,

**...Must Be Closed Out...  
DURING AUGUST.**

Latest Paris Novelties,  
all New Importations  
of this Spring

Together with **LARGE STOCK** of

**ELLIOT CHIME CLOCKS,**

And a Fine Line of Other

**HALL CLOCKS.**

By order of

**ALBERT C. WALL, Esq.,**

Receiver.

**BAWO & DOTTER,**

26-32 BARCLAY ST.

NEW YORK.

P. O. Box 1872.

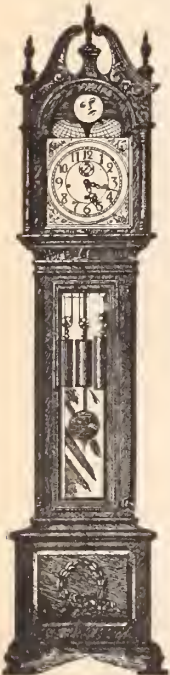

**NO LARGER STOCK**

OF

**HALL  
CLOCKS**

IS SHOWN IN  
THIS CITY.

Large Stock  
OF  
**MOVEMENTS.**

**NEW DESIGNS  
IN CASES.**

**STERLING**

Sheet and Wire Supplied. All Sizes.

**J. SCHAWEL & CO.,**

Gold, Silver and Platinum Refiners,

29 JOHN STREET, NEW YORK.

**AMERICAN WATCH CASE CO.,**

11 JOHN STREET, NEW YORK.

Manufacturers of **FINE SOLID GOLD CASES.**

**A.W.C.CO**

Sold **DIRECT** to  
the **RETAIL TRADE** only.



**34 YEARS OF  
HONEST RETURNS**

IS OUR GUARANTEE OF SATISFACTION  
TO ALL OUR CUSTOMERS.

**WE DO OUR OWN SMELTING,**

**JOHN AUSTIN & SON,**

ASSAYERS, REFINERS AND SMELTERS,

74 & 76 Clifford St., Providence, R. I.

**PRIZE**

**MEDALS**

From

**EXCLUSIVE**

**DESIGNS,**

for out-door

Sports.

Club Pins

of every

description.

**HENRY C. HASKELL.**

11 John Street, New York.

Send for estimates.



610

**ROY PHOTO MINIATURES**  
GIVE THE BEST RESULTS.

**ROY WATCH CASE CO., 23 MAIDEN LANE, NEW YORK.**

**DUBOIS WATCH CASE CO.**

TRADE  MARK

REGISTERED.

**FINE HAND MADE  
SOLID GOLD CASES.**

A PRIDE TO THE MAKER,  
DEALER & WEARER.

**CAMPBELL-METCALF SILVER CO.,  
SILVERSMITHS,**



ALL GOODS 925/1000 FINE.  
Factory, Providence, R. I. Offices, New York and San Francisco.

**DIAMONDS** Importers and Cutters. **L. & M. KAHN & CO.,** 172 Broadway, **DIAMONDS**







